

Service Manual

GB

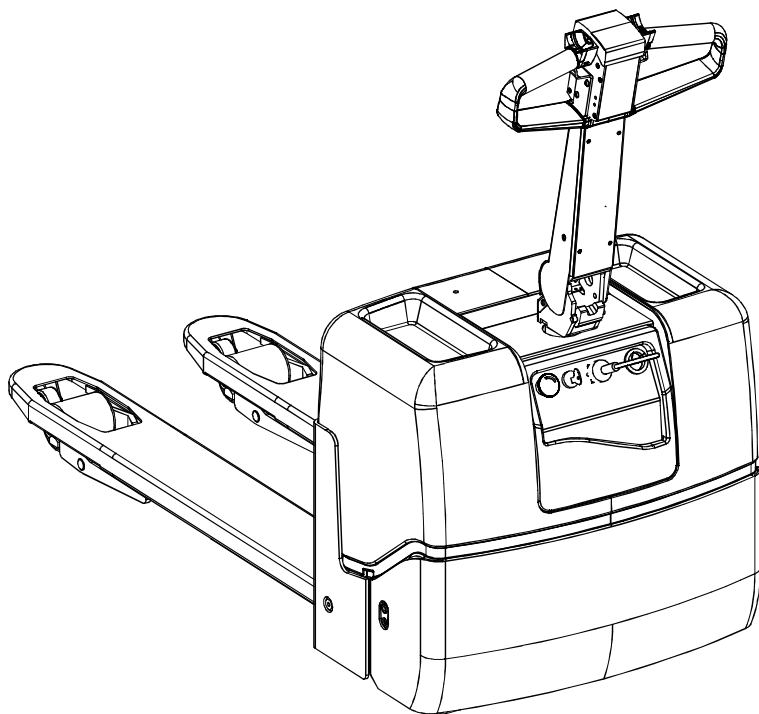

PP 13

Valid from serial number: 372000AA-

Order number: 201012-040

Issued: 2001-10-01 ITS

CLICK HERE TO **DOWNLOAD** THE COMPLETE MANUAL

- Thank you very much for reading the preview of the manual.
- You can download the complete manual from: www.heydownloads.com by clicking the link below



- Please note: If there is no response to CLICKING the link, please download this PDF first and then click on it.

CLICK HERE TO **DOWNLOAD** THE COMPLETE MANUAL



General product information

C-code	T-code	Valid from serial number
	675	372000AA-
Version	Date	Order number
001	2001-10-01	201012-040

Maintenance, Lubrication schedule



Valid from serial number 372000AA-	T-code 675	C-code
Order number 201012-040	Date 2001-10-01	Version 001

I: Inspect, correct and replace if necessary. T: Tighten C: Clean L: Lubricate M: Measure, correct if necessary					
Pos. no.	Work to carry out	Interval in days/weeks/months - may vary due to application			
		1 d	1 w	12 m	36 m
5400	Power system				
5400.1	Cleaning and checking of mounting in chassis			C/T ¹	
5400.2	Re-tighten cable connections			T ¹	
5400.3	Check the contactor points on K10 and K30			I	
5400.4	Check the movement of the contactors			I	
5400.5	Check the cable insulation			I	
5700	Electronic circuit board				
5700.1	Check connectors and cables			T ¹	
6100.	Hydraulic system				
6100.1	Check hoses and connections for wear			I	
6100.2	Check hoses for wear and damage			I	
6100.3	Check the oil tank for cracks, leakage and damaged mountings			I	
6100.4	Check that the oil level is correct		I	I	
6100.5	Change the oil and clean the filter			L ⁵	
6600.	Lift cylinder				
6600.1	Check for leakage			I	
6600.2	Check the mountings			I	

1 = The connections are re-tightened every 12 months.

2 = Retighten securing bolts to 45 Nm every 12 months.

3 = The drive gear is replaced when its diameter is < 235 mm. Drive wheel bolts are retightened every 12 months to 20 Nm.

4 = Check for leakage when changing the grease for the first time.

5 = The oil is changed and the filter cleaned for the first time after 12 months, and then every 24 months



Drive unit/drive gear

C-code	T-code	Valid from serial number
2550	675	372000AA-
Version	Date	Order number
001	2001-10-01	201012-040

2.4 Brakes, Maintenance

In general the brakes require no maintenance when used in a normal working environment. However, according to the chart for preventive maintenance it is recommended that the brake discs are regularly inspected with regard to wear.

2.5 Replacing the brake disc

The brake disc should be replaced when its overall thickness has decreased to 5.5 mm.

- Disconnect the electrical cables routed to the brake.
- Loosen and remove the two securing bolts.
- Loosen the brake disc from the hub and check the wear. Replace the brake disc if the surface shows signs of uneven wear.
- Assemble the brake again.
- Connect the electrical cables.



Electrical systems

Valid from serial number 372000AA-	T-code 675	C-code 5000
Order number 201012-040	Date 2001-10-01	Version 001

3.6 Lowering the forks

- S10 closed.
- S41 activated.

3.7 Horn

- S10 closed.
- S18 activated.

4 Error codes

4.1 Diagnosis and trouble shooting

The Status LED is dimmed under normal operating conditions without faults. If the regulator discovers a fault, a single digit code flashes until the fault is rectified, see the table below.

When a hand terminal is used in diagnostic mode for trouble shooting, information regarding the diagnosis can be read off on the terminal's display, see the table below.

LED-code		Hand terminal LCD-display	Description	Possible cause
1	▣	<i>Logic failure #1</i>	Problem with Logic or main contactor	Electronic card failure
1	▣	<i>Watch-dog</i>	Electronic card and/or software failure	
1	▣	<i>EEPROM KO</i>	EEPROM or Logic problem	
2	▣▣	<i>INCORRECT START</i>	Starting sequence for travel not correct	ENABLE micro switch fused or faulty Operator starting sequence error Wiring error

CLICK HERE TO **DOWNLOAD** THE COMPLETE MANUAL

- Thank you very much for reading the preview of the manual.
- You can download the complete manual from: www.heydownloads.com by clicking the link below



- Please note: If there is no response to CLICKING the link, please download this PDF first and then click on it.

CLICK HERE TO **DOWNLOAD** THE COMPLETE MANUAL