

# Tigercat<sup>®</sup>

## 250D LOADER

# SERVICE MANUAL

SERIAL NUMBER 2502161–2504000



ISSUE 1.1, DECEMBER 2018

**Tigercat Industries Inc.**

P.O. Box 637  
Brantford, Ontario  
Canada N3T 5P9

Tel: (519) 753-2000

Fax: (519) 753-8272

CLICK HERE TO **DOWNLOAD** THE COMPLETE MANUAL

- Thank you very much for reading the preview of the manual.
- You can download the complete manual from: [www.heydownloads.com](http://www.heydownloads.com) by clicking the link below



- Please note: If there is no response to CLICKING the link, please download this PDF first and then click on it.

CLICK HERE TO **DOWNLOAD** THE COMPLETE MANUAL

# Tigercat 250D Loader

## SECTION 1–SAFETY

Read and understand the entire contents of this manual, and all manuals for any attachments or accessories associated with this machine, prior to operating or servicing this equipment.

### CONTENTS–SECTION 1

ISSUE 2.1, DECEMBER 2018

AVOID INJURY FROM BACKOVER ACCIDENTS .....	1.9
BATTERY DISCONNECT SWITCH .....	1.13
BATTERY SAFETY .....	1.8
CAB EXITS .....	1.11
INTERLOCK SWITCH–LEFT ARMREST .....	1.11
COOLING SYSTEM .....	1.15
DIESEL EXHAUST FLUID (DEF) .....	1.10
EXHAUST FUMES .....	1.15
FIRE PREVENTION	
DRY CHEMICAL CLEANUP PROCEDURES .....	1.27
FIRE PREVENTION GUIDELINES .....	1.24
WHAT TO DO AFTER A MACHINE FIRE HAS OCCURRED .....	1.27
WHAT TO DO TO PREPARE FOR A MACHINE FIRE .....	1.25
WHAT TO DO WHEN A MACHINE FIRE OCCURS .....	1.26
FLUID INJECTION INJURY .....	1.19
GENERAL SAFETY PRECAUTIONS .....	1.4
GREASE INJECTION INJURY .....	1.20
HAZARD ZONE .....	1.4
INTERLOCK SWITCH–LEFT ARMREST .....	1.11
LIGHTNING SAFETY AWARENESS .....	1.21
LIGHTNING SAFETY .....	1.21
WHAT IS A LIGHTNING STRIKE? .....	1.21
LOOSE CLOTHING HAZARD .....	1.16
NOTICE LABELS .....	1.36
OPERATING SAFETY PRECAUTIONS .....	1.10
PARKING THE MACHINE .....	1.13
PROTECTIVE CLOTHING .....	1.4
SAFETY HAZARDS	
OPERATING .....	1.8
VITON SEALS .....	1.7
SAFETY LABELS .....	1.28
SAFETY PRECAUTIONS	
GENERAL .....	1.4
OPERATING .....	1.10
SERVICING .....	1.14

## CAB EXITS

There are two ways to exit the cab in case of an emergency.

### LEFT SIDE DOOR

This is the main point of entry used under normal operating conditions to enter or leave the cab. This door is NOT equipped with a safety interlock switch and if left open will NOT deactivate the pilot system. The left armrest is equipped with a safety interlock switch that prevents machine operation when the armrest is raised. Refer to INTERLOCK SWITCH–LEFT ARMREST in THIS SECTION for more details. Turn OFF the engine and raise the left armrest before using the side door exit.

### RIGHT SIDE WINDOW

This exit is to be used for emergency exit only if the side door exit becomes blocked. This window is NOT equipped with a safety interlock switch and if left open will NOT deactivate the pilot system. Turn OFF the engine before using the side window as an emergency exit route.

#### IMPORTANT!

The operator of the machine must be familiar with these emergency exits and how to use them.

All operators must practice using all the cab exits to become familiar with escape procedures if they need to perform them in the dark, when the machine is in a rolled position, or other possible adverse conditions.

Both exits must be checked frequently to verify they are operational and will function in an emergency.

For additional information, refer to EMERGENCY EXIT in SECTION 2.

## INTERLOCK SWITCH–LEFT ARMREST

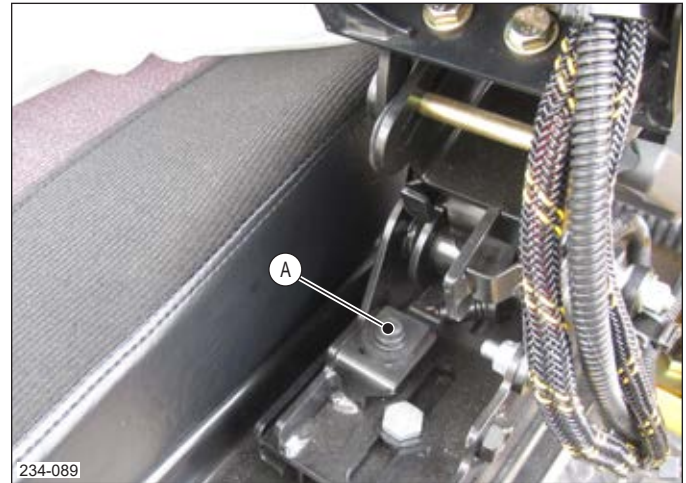

A Interlock switch shown in OFF position with left armrest UP

The left armrest is equipped with a safety interlock switch to prevent the machine from being operated while the armrest is in the raised position (pilot system is turned OFF).

**NOTE:** The engine can be started but the machine functions cannot be operated with the left armrest up.

#### **WARNING**

**The interlock switch and the pilot system reset switch are a safety feature and their function must not be defeated in any way.**

## TO OPERATE

With the engine running and the left armrest DOWN, push the pilot system reset switch.

Once the safety interlock system has been activated, the safety of both the operator and all persons outside the cab becomes the responsibility of the operator.

## LIGHTNING SAFETY AWARENESS

### WHAT IS A LIGHTNING STRIKE?

Lightning is a discharge of the electricity produced by a thunderstorm. As the thunderstorm develops, many small particles of ice within the storm clouds bump together. These collisions create a positive charge at the top of a cloud and a negative charge at the bottom. As this continues a second positive charge builds up on the ground beneath the cloud, concentrated around high objects such as hills, trees, buildings, equipment and even people.

When the difference between the electrical charge in the cloud and on the ground becomes great enough to overcome the resistance of the insulating air between them, an electrical current flows instantly. This is a lightning strike.

The electrical potential in a lightning strike can be as much as 100 million volts. Lightning strikes can occur over very large distances, even as much as 60 km (37 miles). Lightning travels both in front of and behind a thunderstorm and so strikes happen even when rain has not started or has stopped. Lightning can hit in the same place, many times and often spreads out over 18 m (60 feet) within the soil around the strike point.

Thunder always accompanies lightning. When lightning occurs, the air through which it travels is instantaneously heated to a temperature more than 28,000°C (50,000°F). The air expands rapidly due to this heating, then quickly contracts as it cools. It is this contracting shock wave that we hear as thunder.

In many areas of the world, lightning strikes are second only to flooding as the greatest cause of storm related deaths and injuries. Although only 10% of lightning strike victims are killed, virtually all from cardiac or respiratory arrest, over 70% of those that survive suffer severe, life-long injury and disability. The symptoms of a lightning strike include memory loss, fatigue, chronic pain, dizziness, sleeping difficulty and the inability to complete several tasks at one time.

## LIGHTNING SAFETY

In spite of the popular myth that being struck by lightning is an unlikely event, the facts show that lightning strikes occur frequently. As a result loggers are at high risk because their work is outdoors and close to known strike points such as tall trees and heavy equipment.

Loggers can increase their chances of avoiding a lightning strike by following a few simple safety practices:

- Designate a member of your crew to:
  - Monitor daily weather forecasts
  - Observe local weather conditions
  - Alert all other members of the crew when a possible lightning threat develops
- Don't start or continue any work that cannot be stopped immediately, when a storm moves nearby.
- Anticipate a high-risk situation and take action early by moving to a low-risk location. Do not hesitate. If there is lightning, you are in danger.
- Obey the rule - If you see lightning, Flee. If you hear thunder, Clear. Do not follow the now obsolete guideline to take shelter when the time between seeing lightning and hearing thunder is 30 seconds or less. This does not provide sufficient time to ensure safety.
- Remain in your safe location for 30 minutes after the last sight of lightning or the last sound of thunder.

The safest location during lightning activity is inside a fully enclosed, substantially constructed building, a house, office, school, shopping area, etc. These are the safest because of the electrical wiring and plumbing they contain. Should lightning strike, the electrical current will travel through the wiring or plumbing into the ground. When such a building is nearby, always seek shelter there first.

Unfortunately loggers do not often work close to buildings and therefore other alternatives need to be considered.

Sheds, weather shelters, hunting blinds, tents and other partially open or small structures are not safe against lightning strikes as they lack the electrically grounded components of larger buildings. They are intended for sun or rain protection only. Do not seek shelter from lightning strikes inside these structures.

**ENTANGLEMENT HAZARD**

This label warns of an entanglement hazard (rotating parts) zone.

Do not place hands or fingers in this area. Rotating parts such as pulleys, belts and drives can cause entanglement of body parts resulting in serious injury.

**KEEP HANDS AND FINGERS CLEAR OF ROTATING BELT, DRIVE OR PULLEY!** Before performing any service work on these parts or in this area, shut engine off and wait for rotating parts to come to a complete stop.

**ELECTROCUTION HAZARD**





This label warns of a potential **electrocution hazard**. Contact with electric lines will result in death or serious injury!

Before beginning work in any area study the area thoroughly and become familiar with any potential hazards especially electrocution hazards from electric lines.





**DO NOT MOVE ANY PART OF THE MACHINE OR LOAD WITHIN 3 m (10 ft) PLUS TWO TIMES LINE INSULATOR LENGTH OF ANY ELECTRIC LINES!**

















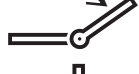

**PICTOGRAM DESCRIPTIONS**

Diagrams in pictorial form are used to represent machine function operation. They are a simple universal language of symbols or pictograms that illustrate a function or component without the use of words.

Examples of these pictograms are the turtle  and the rabbit , often used to describe speed such as SLOW =  or FAST = .

The pictograms used on this machine are as follows:

-  = 12V, Auxiliary Power Outlet
-  = 24V, Auxiliary Power Outlet
-  = ACCEPT
-  = Adjustment Menu
-  = Air Conditioner ON
-  = Air Conditioner OFF
-  = Air Intake Pressure, BOOST
-  = Air Source, Fresh Air
-  = Alert Message Symbol
-  = Battery CONNECT and VOLTAGE
-  = Battery DISCONNECT
-  = Boom DOWN, Hoist

-  Boom UP, Hoist
-  = Boom IN, Stick
-  = Boom OUT, Stick
-  = Boom IN, Heel
-  = Boom OUT, Heel
-  = Brake Pedal
-  = Butt Board DOWN
-  = Butt Board UP
-  = Check, Visually
-  = Cigarette Lighter, 24 Volt
-  24V
-  = Control Lever Multiple Direction
-  = Control Lever One Direction
-  = Control Lever Two Direction
-  = CRITICAL ERROR Message
-  = CRITICAL Message
-  = Diesel Exhaust Fluid (DEF) T4 ONLY
-  = Defrost, Front Window

**AC16 MACHINES WITH CIRCLE SAW-LIVE HEEL**

**JOYSTICK-LEFT**

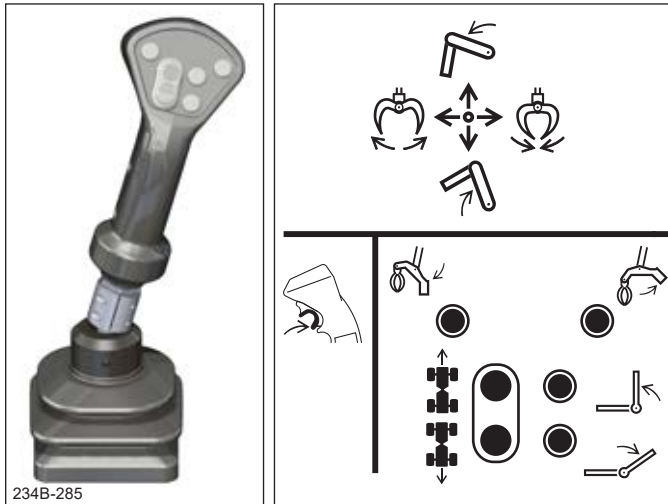

**HOIST BOOM**

- Move the joystick FORWARD to LOWER the hoist boom.
- Move the joystick BACK to RAISE the hoist boom.

**GRAPPLE OPEN/CLOSE**

- Move the joystick to the LEFT to OPEN the grapple arms.
- Move the joystick to the RIGHT to CLOSE the grapple arms.

**LIVE HEEL**

- Press and hold the TOP LEFT button to tilt the heel OUT.
- Press and hold the TOP RIGHT button to tilt the heel IN.

**TRAVEL DIRECTION**

- Press and release the BOTTOM LEFT rocker switch FORWARD to travel FORWARD and BACK to travel in REVERSE.

**BUTT BOARD**

- Press and hold the MIDDLE RIGHT button to RAISE the butt board UP.
- Press and hold the BOTTOM RIGHT button to LOWER the butt board DOWN.

**JOYSTICK-RIGHT**

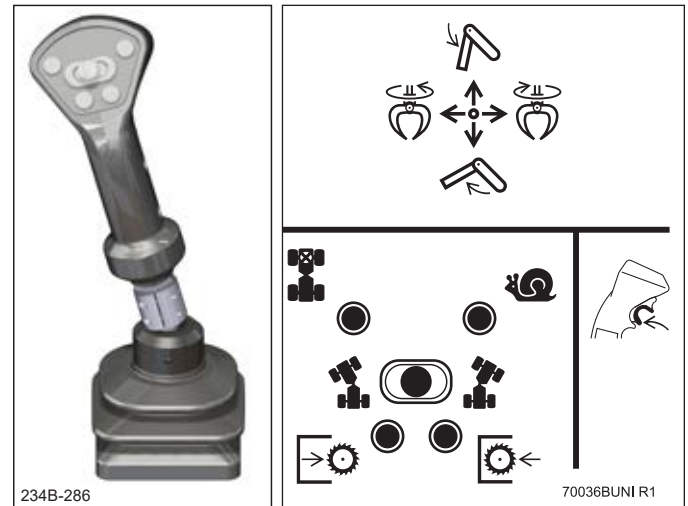

**STICK BOOM**

- Move the joystick FORWARD to move the stick boom IN.
- Move the joystick BACK to move the stick boom OUT.

**GRAPPLE ROTATE**

- Move the joystick to the LEFT to rotate the grapple COUNTERCLOCKWISE.
- Move the joystick to the RIGHT to rotate the grapple CLOCKWISE.

**DIFFERENTIAL LOCK**

- Press and release the TOP LEFT button to ENGAGE the differential lock. Press and release again to DISABLE.

**CREEP MODE**

- Press and release the TOP RIGHT button to ENABLE creep mode. Press and release again to DISABLE.

**STEERING**

- Slide the MIDDLE SLIDER switch to the LEFT to steer the machine LEFT and to the RIGHT to steer the machine RIGHT.

**CIRCLE SAW**

- Press and release the BOTTOM LEFT button to EXTEND (cut) with the circle saw.
- Press and release the BOTTOM RIGHT button to RETRACT the circle saw.

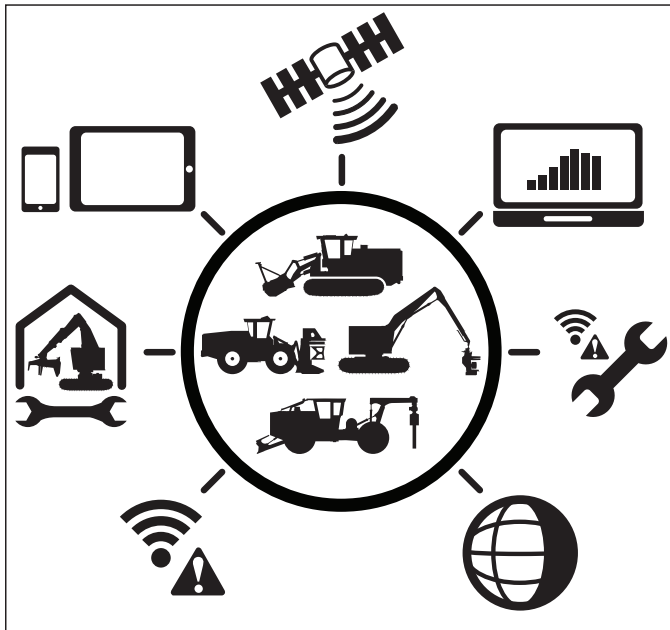
**TELEMATICS SYSTEM (OPTIONAL)**

Telematics is a tool used by owners, operators, or service technicians to monitor a machine or fleet of machines. Monitoring the location, movements, fuel status, fault codes or a variety of other parameters is done using a web enabled device.

**NOTE:** Leave the ignition key switch in the RUN position for several minutes to allow the telematics module to fully power up after it has been powered off.

Refer to **TELEMATICS SYSTEM** in **SECTION 6** of the **SERVICE MANUAL** for additional information.

**WINDOWS**

A Sliding Window Handle

The right window and cab door window are sliding windows. To open, push on the handle and slide the window. To close, slide the window firmly until it stops and latch the handle to the frame.

On self propelled and AC16 mounted machines, both windows are equipped with an exterior screen to provide personal protection of the operator. Each screen is held closed with two hand knobs, one inside the cab and one outside the cab. Removing either hand knob will open the window screen.

**IMPORTANT!**

All window screen hand knobs should be hand-tight only at all times.

**EMERGENCY EXIT****RIGHT SIDE WINDOW**

The right side window serves as an emergency exit if the side door exit becomes blocked.

1. Turn OFF the engine before using this exit.
2. Push the latch handle and slide the window fully open.

ENGINE FUNCTIONS

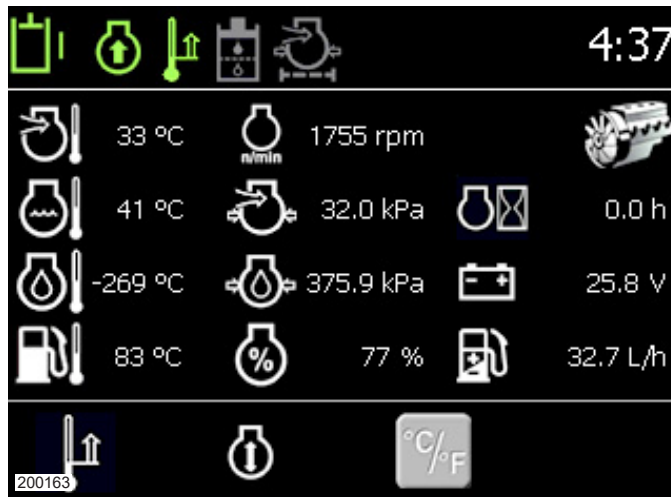

 CHARGE AIR TEMPERATURE

This display indicates the charge air temperature reading.

If temperature rises above the recommended temperature a message is sent to the computer display and an alarm will sound. Check for the following:

- Plugged cooler package access door screen.
- Plugged charge air cooler.

Do not continue to operate the machine.

Refer to CLEANING COOLER PACKAGE in SECTION 3 and COMPUTER–MESSAGES in THIS SECTION.

 ENGINE COOLANT TEMPERATURE

This display indicates the current engine coolant temperature.

If temperature rises above the recommended temperature a message is sent to the computer display and an alarm will sound. Check for the following:

- Plugged cooler package access door screen.
- Plugged radiator.

Do not continue to operate machine

Refer to CLEANING COOLER PACKAGE in SECTION 3 and COMPUTER–MESSAGES in THIS SECTION.

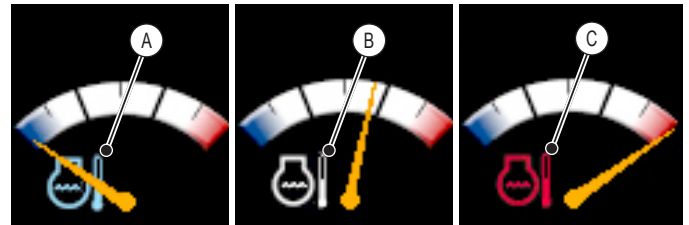

- A Engine Temperature Low
- B Engine Temperature Normal
- C Engine Temperature High

**NOTE:** Coolant temperature can also be monitored using the engine coolant temperature gauge on the main screen. The changes in gauge symbol colour indicate temperature range (BLUE=low, WHITE=normal, RED=high).

TELEMATICS INFORMATION

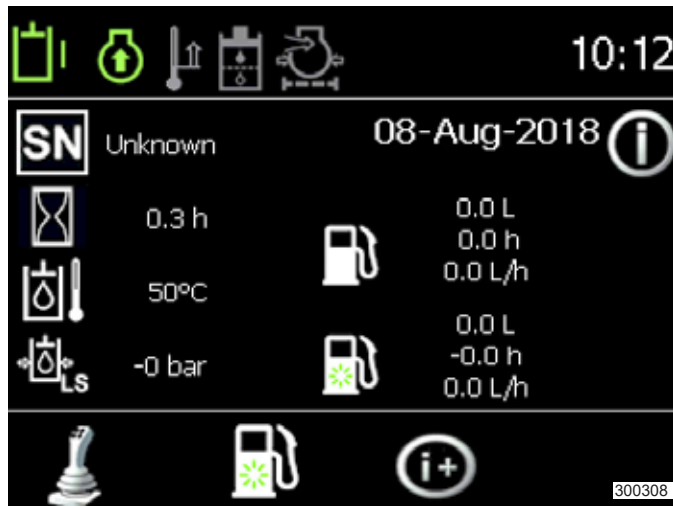



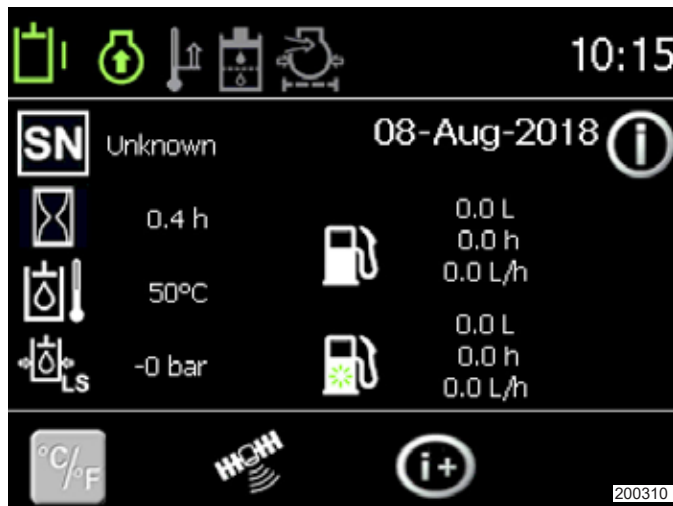

Press the F3 button to access the additional information screen.

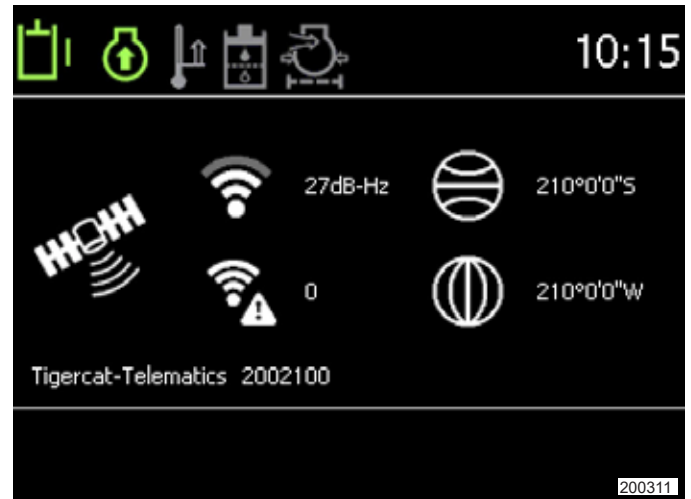

Press the F2 button to show the Telematics information.



When selected, the information functions displayed are:

-  Telematics Symbol
-  Telematics, Connectivity
-  Telematics, Messages Sent/Recorded
-  Telematics, Latitude
-  Telematics, Longitude

Press the back button to return to the Information menu.  
Press the back button again to return to the main screen.

## MEASURE MENU

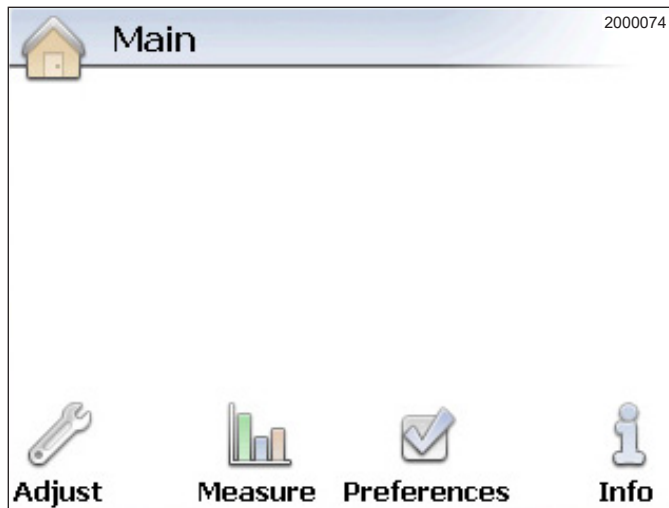

Press the F2 button to access the Measure menu.

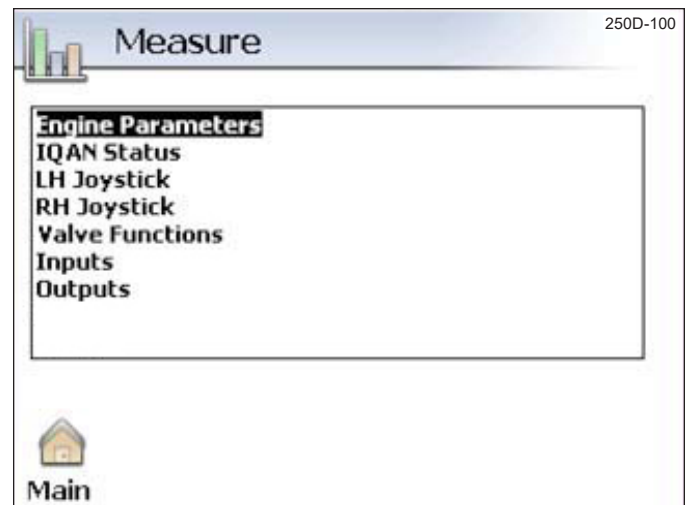

This menu is used by Tigercat service technicians. Refer to SECTION 6 of the SERVICE MANUAL for more information.

Press the UP or DOWN arrow buttons to select the menu item.

Press the OK button to view the information from the menu item.

Press the back button to return to the Measure menu or press the F1 button to return to the Main menu.

Press the back button from the Main menu to return to the main screen.

**LIST OF CRITICAL MESSAGES**

Critical Message	Message Header	Message Text
Engine Coolant Level Low	Engine Coolant	Level Low.
Engine Coolant Temperature High–Engine Derate	Engine Coolant	Temperature High - Engine Derate.
Main Fuel Filter Clogged–Engine Derate	Main Fuel Filter	Clogged - Engine Derate.
Boost Pressure Low–Engine Derate	Engine Boost Pressure	Boost Pressure Low - Engine Derate.
Hydraulic Oil Level Low	Hydraulic Oil	Level Low.
Hydraulic Oil Temperature High	Hydraulic Oil	Temperature High.
Engine Oil Pressure Low–Engine Derate	Engine Oil	Pressure Low - Engine Derate.
Hardware Fault	Hardware Fault - (Module Name)	Active fault has been hidden. Turn key off and on to recall active hidden hardware faults.
Engine Fault Code Messages–Critical	SPN: #####	Contact dealer.
Engine Oil Pressure Low	SPN: 9939	Engine Oil Pressure Low.
Engine Coolant Temperature High	SPN: 63011	Engine coolant temperature high.
Engine Oil Temperature High	SPN: 7123	Engine oil temperature high.
Aftertreatment System Technical Failure *	After Treatment System	Technical failure severe. Engine lockout will occur after full torque derate and 3 engine restarts.
Engine Restarts Remaining Until Engine Lockout *	Engine	Number of restarts remaining.
Engine Locked Out *	Engine	Engine locked out. Engine derate to 0% Torque and 850 rpm. Contact dealer.
Aftertreatment System Engine Idle Too Long *	After Treatment System	Engine idle too long. Shut down engine to prevent damage to emission control system.

\* **NOTE:** The aftertreatment system and its related components are applicable to Tier 4f machines only.

**ENGINE COOLANT LEVEL LOW**

This message will be displayed, alarm light will flash and alarm will sound when the coolant level drops below a safe operating level. The sensor is located in the surge tank.

If this light comes on when the engine is running, turn OFF the engine immediately and correct the fault. With engine running, top up the surge tank using correct solution of engine coolant.

Refer to SERVICE AND LUBRICATION POINTS in SECTION 3.

WARNING



**Do not remove the radiator fill cap when the engine is hot, release of pressurized coolant can cause serious burns.**

**Turn OFF the engine. Only remove the radiator fill cap when cool enough to touch with bare hands.**

**Slowly loosen the cap to the first stop to relieve pressure before removing completely.**

**ENGINE AIR INTAKE FILTER RESTRICTED**

This message will be displayed when a signal is received from the restriction indicator sensor on the engine air cleaner.

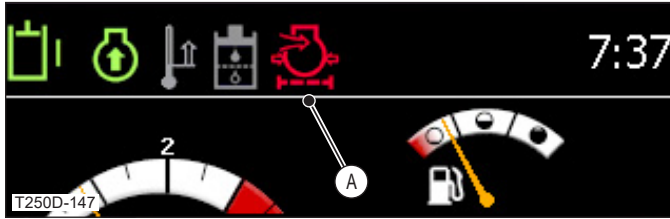

A Engine Air Intake Filter Restriction Icon–ON (Red)

The engine air intake filter restriction icon on the computer display will also illuminate RED.

When this happens the engine air cleaner requires immediate service.

Refer to AIR INTAKE SYSTEM–AIR CLEANER in SECTION 3.

**HYDRAULIC OIL FILTER RESTRICTED**

This message will be displayed when an oil flow restriction in excess of 1.4 bar (20 psi) is encountered at the hydraulic oil return filters. If pressure continues to build up to 1.7 bar (25 psi) the bypass valve in the filter head opens allowing oil to bypass the filter elements and return to the hydraulic oil tank .

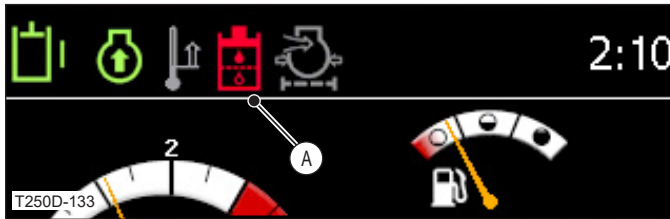

A Hydraulic Oil Filter Restricted Icon–ON (Red)

The hydraulic oil filter restriction icon on the computer display will also illuminate RED.

If this message appears, replace all four hydraulic oil return filters to prevent contamination to the hydraulic system which could lead to damage to hydraulic components.

Refer to FILTERS–HYDRAULIC OIL RETURN in SECTION 3.

**MAIN FUEL FILTER CLOGGED**

This message will be displayed when a main fuel filter clog is detected.

Replace engine fuel filter to prevent engine derate. Refer to ENGINE OPERATION AND MAINTENANCE MANUAL for engine fuel filter replacement instructions.

When a fuel filter clog continues for more than 5 minutes a critical message will be shown and the engine will immediately begin to derate. Refer to COMPUTER–MESSAGES–CRITICAL–MAIN FUEL FILTER CLOGGED–ENGINE DERATE in THIS SECTION.

**FUEL LEVEL LOW**

This message will be displayed when the fuel level falls below 5% of full.

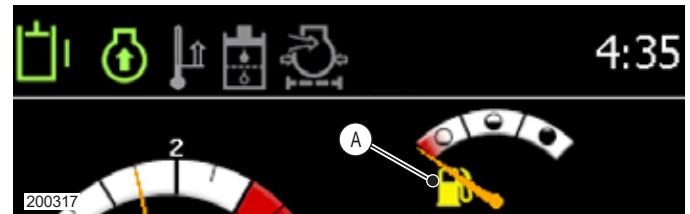

A Fuel Icon–Low (Yellow)

The fuel icon will also illuminate yellow when the fuel level is low.

Refer to REFUELLING PROCEDURE in SECTION 3.

**CHARGE FILTER BYPASSED**

This message will be displayed when an oil flow restriction in excess of 3.5 bar (50 psi) is encountered at the swing pump charge pressure filter and hydraulic oil is bypassing the filter.

Refer to FILTERS–SWING PUMP CHARGE PRESSURE in SECTION 3.

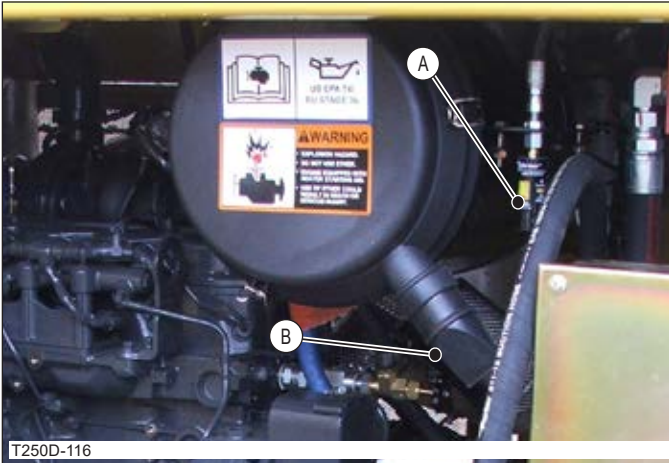

- A Air Intake Filter Restriction Indicator
- B Air Cleaner Unloader Valve

11. Check the air filter restriction indicator. Service to the air filter is required when the restriction indicator shows RED. Refer to AIR INTAKE SYSTEM–AIR FILTER RESTRICTION INDICATOR in SECTION 3.
12. Check the air cleaner unloader valve.

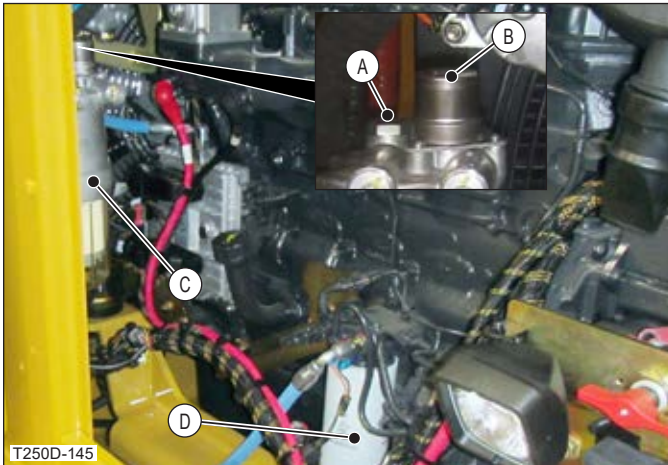

- A Vent Plug
- B Hand Primer Pump
- C Fuel Filter/Water Separator
- D Engine Fuel Filter

13. Check the fuel filter/water separator and drain any accumulated water into a bowl and clean up any spills. Refer to FILTERS–FUEL FILTER/WATER SEPARATOR in SECTION 3.

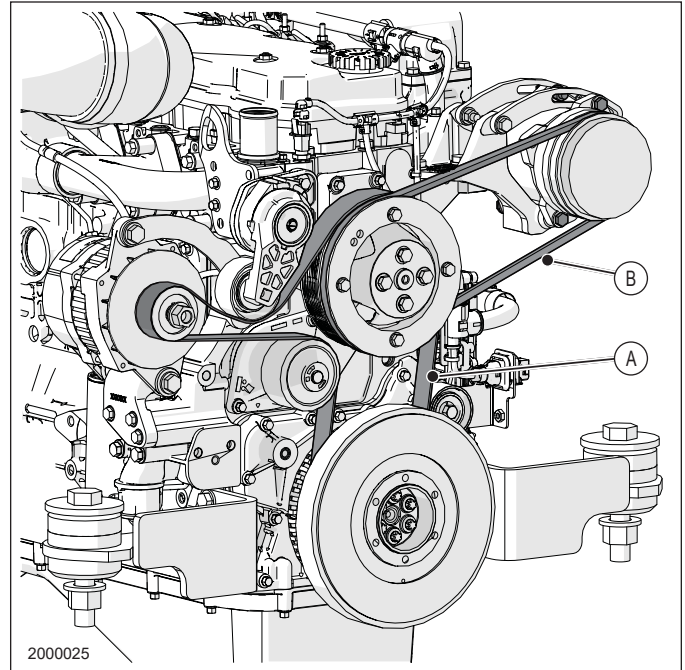

- A Serpentine Belt (Fan not shown)
- B A/C Compressor Belt

14. Check tension and condition of all engine belts. Refer to AIR CONDITIONING SYSTEM–ENGINE BELTS in SECTION 3 for adjustment details.



- A Engine Coolant Surge Tank
- B Engine Coolant Fill Cap
- C Engine Coolant Level Sight Glass

15. Check the engine coolant level in the surge tank. Fill as required. Coolant level must be visible in the sight glass.

**NOTE:** A low level sensor warns the operator if the coolant level falls below an acceptable level.

## TRANSPORTING THE TRAILER MOUNTED LOADER

The transporting procedure given is intended only as a guide and may not be complete or may differ from actual practice due to local regulations.

**NOTE:** It is the responsibility of the owner of the machine to ensure the installation, mounting and transporting of the loader is safe and complies to all local, state, provincial and federal regulations applicable for their region.

 **WARNING**

**Improper loading or transportation of the loader can lead to accidents resulting in serious injury, death and property damage.**

1. Mount loader to trailer as described in TRAILER MOUNTING/INSTALLATION in THIS SECTION.
2. Start loader and rest or attach grapple and/or boom to the trailer such they are sufficiently secure and are within all height and width restrictions. Refer to trailer manufacturer for information on proper location and procedure for attaching grapple and/or booms.
3. Raise all four stabilizers to their fully upright positions. Stop the engine.
4. If the machine is equipped with a cab riser lower the cab to its transporting position. See CAB TILTING PROCEDURE in THIS SECTION.
5. Turn OFF the battery disconnect switch.
6. Ensure the setup conforms to all applicable local, state, provincial and federal regulations for mounting and transporting equipment. Check height, width and weight restrictions.

**CHECK EMERGENCY EXIT MONTHLY**

A Right Cab Window Latch Handle

The left cab door is the primary exit. One alternate exit route is provided:

- Right cab sliding window.

The right cab sliding window is only to be used if the cab door cannot be opened.

Check emergency exits monthly to ensure they are fully operational.

**Tigercat Model 234B/250D Loader  
SERVICE AND LUBRICATION POINTS**

THIS CHART IS INTENDED FOR A QUICK REFERENCE.

ADDITIONAL SERVICE INFORMATION IS CONTAINED IN THE **Tigercat** OPERATOR'S MANUAL FOR THIS MACHINE.

SERVICE POINT NO.	ITEM	SERVICE EVERY						CAPACITY			DESCRIPTION
		8 ⌘	125 ⌘	250 ⌘	500 ⌘	1000 ⌘	2000 ⌘	LITER	US GAL	QTY	
1	COOLING SYSTEM	CHK	CHANGE COOLANT EVERY 2 YEARS				30	8		SEE ENGINE MANUFACTURER'S OPERATION AND MAINTENANCE MANUAL FOR REQUIRED ANTIFREEZE SOLUTION AND MIXTURE.	
2	ENGINE OIL AND FILTER	CHK •		REP •				•	•		• SEE ENGINE MANUFACTURER'S OPERATION AND MAINTENANCE MANUAL FOR PROCEDURES AND CAPACITIES.
3	FUEL FILTER (ENGINE)			REP •						1	
4	CRANKCASE VENTILATION FILTER - T4F ONLY				REP					1	SEE ENGINE MANUAL FOR PROCEDURES.
5	FUEL/WATER SEPARATOR	DRN		REP						1	REFER TO SECTION 3 OF THE MANUAL FOR DETAILS
6	DEF DOSING MODULE FILTER - T4F ONLY			REP							
7	INTANK FUEL STRAINER					CHK				1	DRAIN TANK, CLEAN OR REPLACE AS NECESSARY
8	AIR INTAKE PRECLEANER	CHK								1	CLEAN AS REQUIRED / INSPECT IMPELLER FOR WEAR OR DAMAGE REPLACE AS NECESSARY
9	AIR INTAKE PRIMARY FILTER ELEMENT	CHK								1	CHECK FILTER RESTRICTION INDICATOR. REFER TO 8 HOUR SCHEDULED MAINTENANCE FOR DETAILS.
	AIR INTAKE SAFETY FILTER ELEMENT	CHK								1	
10	AIR CLEANER UNLOADER VALVE	CHK				REP				1	REFER TO OPERATOR'S MANUAL SECTION 2 FOR DETAILS
11	AIR INTAKE CONNECTIONS	CHK					REP			1	CHECK FOR LOOSE CLAMPS AND DAMAGED RUBBER COMPONENTS. REPLACE RUBBER COMPONENTS.
12	HYDRAULIC TANK	CHK					D/R	250	66		DRAIN AND REFILL AS REQUIRED BY SEASONAL OIL CHANGE. SEE APPROVED HYDRAULIC OILS IN THE MANUAL.
13	RETURN FILTERS (4 ELEMENTS) 3 STANDARD FILTERS 1 WATER ABSORBING FILTER		CHK		REP †					4	CHECK FILTER RESTRICTION INDICATOR, ON FILTER HEADS WITH ENGINE RUNNING AT HIGH IDLE AND WITH OIL FLOW
14	PRESSURE FILTER, PILOT				REP †					1	
15	SWING GEARBOX	CHK				D/R		◆	◆	1	◆ HALF FILL RESERVOIR WITH SAE 75W90 EP OIL
16	GRAPPLE, <b>Tigercat</b>	SEE LUBRICATION POINTS DIAGRAM									
	GRAPPLE, OTHER MANUFACTURERS	SEE MANUFACTURER'S MAINTENANCE SCHEDULE									
17	FIRE EXTINGUISHER			CHK						1	TURN TO MIX CONTENTS
18	SWING PUMP CHARGE PRESSURE FILTER				REP †					1	

**LEGEND**



LUBRICATION POINT WITH A DESIGNATED NUMBER OF FITTINGS (2 FTG) AND HOURS BETWEEN SERVICING (125). EXCEPT WHERE SPECIFIED, PURGE WITH LITHIUM BASED EP2 GREASE CONTAINING MOLYBDENUM DISULFIDE "MOLY".

\*\* DO NOT USE A POWER GREASER. REFER TO SCHEDULED MAINTENANCE: EVERY 250 HOURS IN SECTION 3 OF THE MANUAL FOR DETAILED INSTRUCTIONS. INCORRECT LUBRICATION MAY RESULT IN GEARBOX FAILURE.

† USE OF FILTERS OTHER THAN GENUINE TIGERCAT REPLACEMENT FILTERS IS NOT RECOMMENDED.



..... HOURS

CHK ..... CHECK

REP ..... REPLACE

DRN ..... DRAIN

D/R ..... DRAIN AND REFILL

CLN ..... CLEAN

HYDRAULIC SYSTEM COMPONENTS

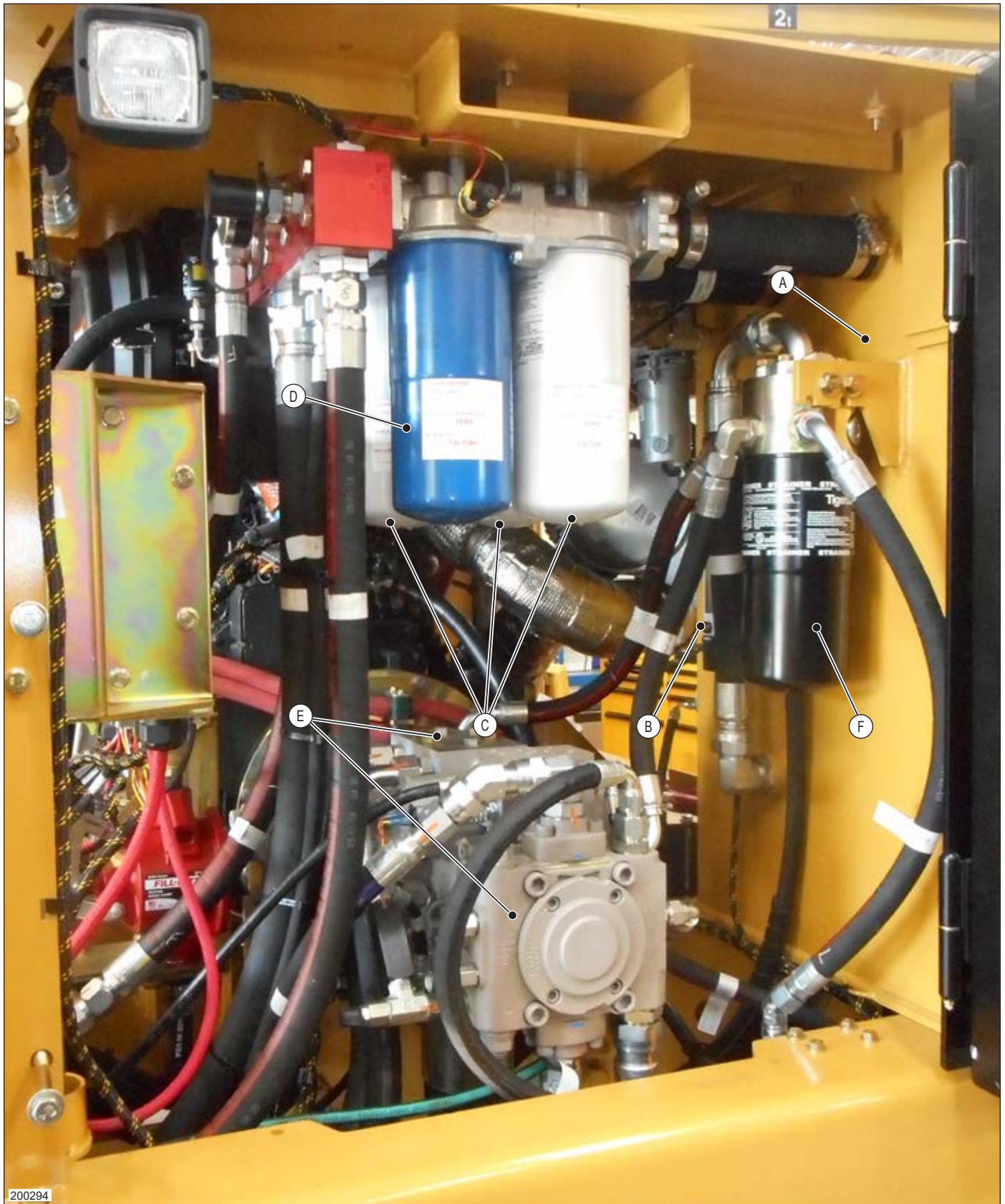

200294

- A Hydraulic Oil Tank
- B Hydraulic Oil Level Sight Gauge and Low Level Sending Unit
- C Hydraulic Oil Return Filters (White—Qty 3)

- D Water Absorbent Filter (Blue—Qty 1)
- E Hydraulic Pumps
- F Case Drain Strainer (Black)

## ENGINE COOLANT HEATER UNIT (OPTIONAL)

### COMPONENTS

#### COOLANT HEATER UNIT

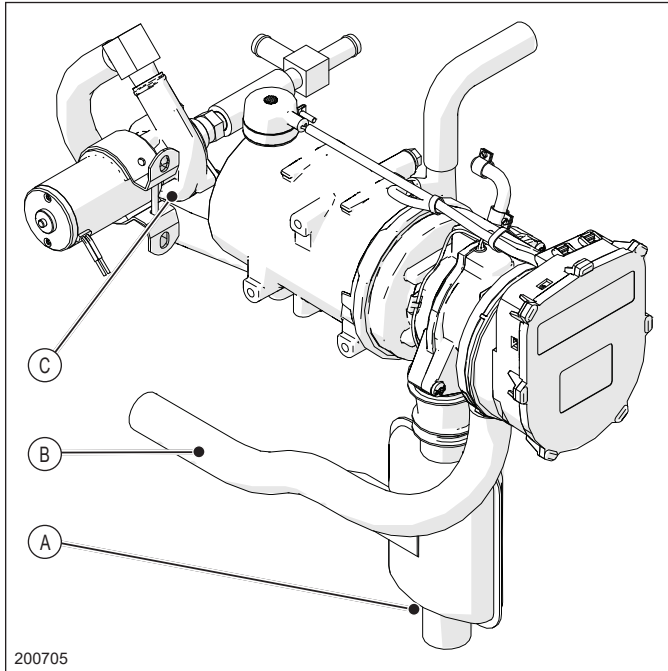

200705

#### Engine Coolant Heater Unit

- A Exhaust Port
- B Intake Port
- C Coolant Pump

The coolant heater unit is located below the hydraulic oil tank at the lower left rear of the upper structure.

The engine coolant heater uses circulating coolant to heat the hydraulic oil. Refer to ENGINE COOLANT HEATER UNIT (OPTIONAL) in SECTION 10 for additional information on the coolant heater.

#### COOLANT PUMP

The coolant pump is located in front of the coolant heater unit.

The coolant pump circulates the coolant to heat the hydraulic oil. Refer to ENGINE COOLANT HEATER UNIT (OPTIONAL) in SECTION 10 for additional information on the coolant pump.

### CONTROLS



2000013

#### Overhead Console—Front

- A Engine Coolant Heater Control Panel

The engine coolant heater control panel is located on the overhead console at the front of the cab.

Refer to ENGINE COOLANT HEATER CONTROL (OPTIONAL) in SECTION 2 for additional information and operating instructions.

**EVAPORATOR, HEATER CORE AND BLOWERS**

Liquid refrigerant flows into the evaporator coil. As the blowers pull the warm cab air across the evaporator coil, heat is absorbed by the refrigerant. This results in cooling of the air as it passes across the evaporator coil. When enough heat is absorbed by the refrigerant, the refrigerant changes to a low pressure vapour.

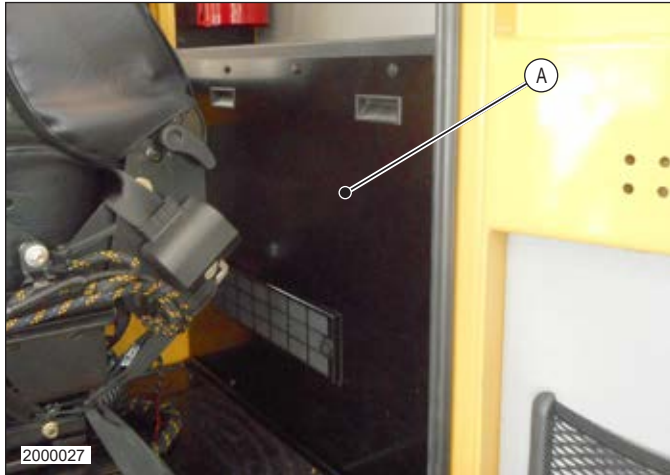

A A/C Heater Unit Cover Panel  
B A/C Heater Unit

The evaporator core, heater core and blowers are a part of the A/C heater unit located in the cab behind the operator's seat.

To inspect the evaporator and blowers do the following:

1. Park the machine on level ground. Refer to PARKING THE MACHINE in SECTION 1.
2. Slide the operator's seat as far forward as possible and adjust the seat backrest as far forward as possible.
3. Remove the six socket head capscrews fastening the A/C heater unit cover panel and remove the panel.

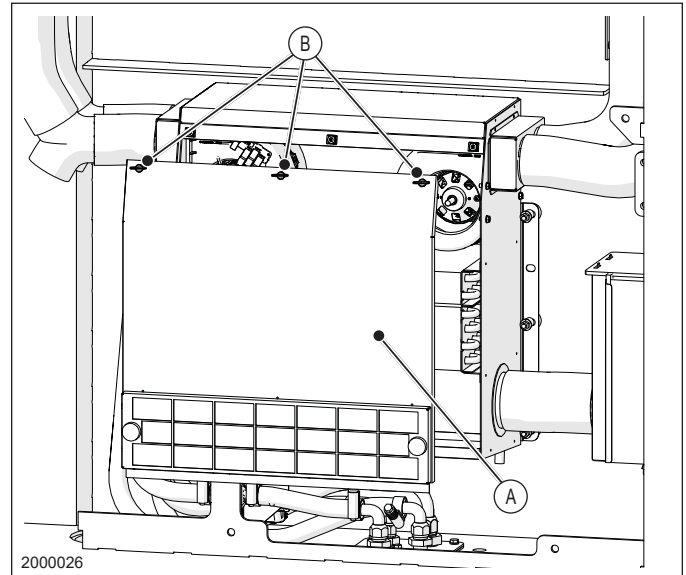

A A/C Heater Unit Access Cover  
B Thumb Screws

4. Remove the A/C heater unit access cover thumb screws and remove the access cover.

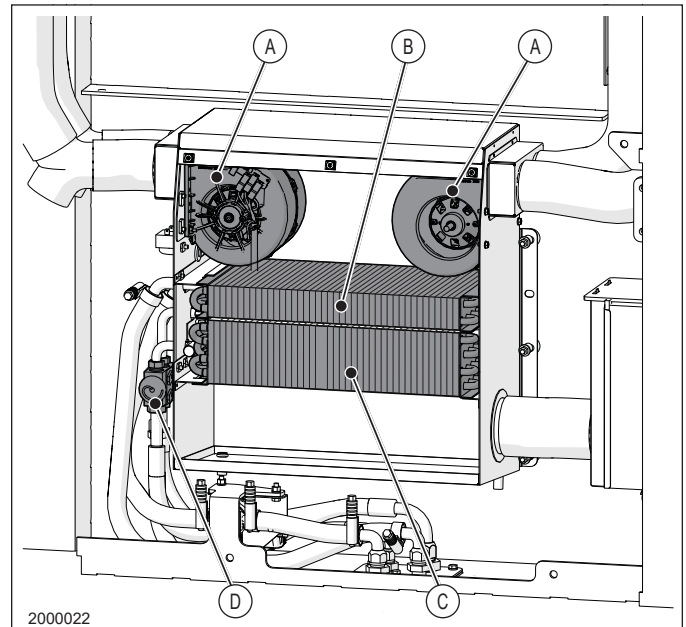

A Blower  
B Heater Core  
C Evaporator Core  
D Expansion Valve

5. Inspect the evaporator core, heater core and blowers for dirt and debris. Remove if required.
6. Install the A/C heater unit access cover and fasteners.

### CHANGING FUEL FILTER/WATER SEPARATOR

Refer to SCHEDULED MAINTENANCE and SERVICE AND LUBRICATION POINTS in THIS SECTION for filter replacement intervals.

1. Park the machine on level ground. Refer to PARKING THE MACHINE in SECTION 1.
2. Drain the fuel from the filter/water separator as described previously in this section.
3. Disconnect the fuel heater and the 'water-in-fuel' sensor from the wiring harness.

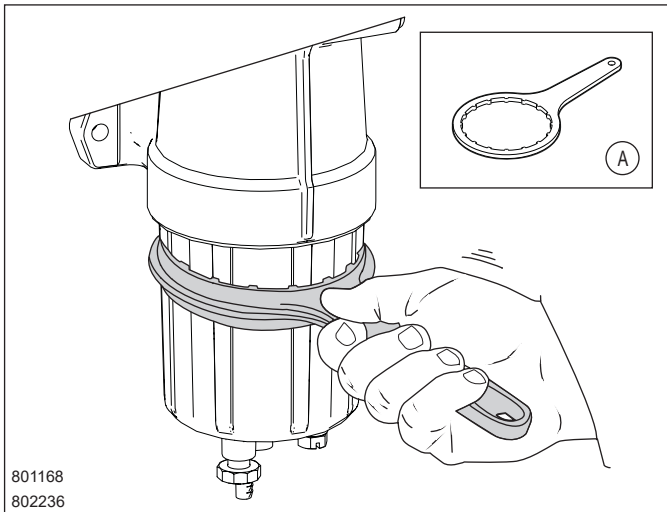

801168  
802236

A Filter Removal Tool (BH859)

4. Remove the water separator bowl from the filter head.
 

**NOTE:** A bowl wrench is supplied with the machine (Tigercat Part Number: BH859).
5. Dispose of any fuel properly.
6. Remove and discard the O-ring from the top of the separator bowl.
7. Clean the separator bowl.
8. Remove the filter cartridge from the filter head (pressure fit) and discard properly.
9. Place the new filter into position on the filter head.
10. Lubricate the O-ring with clean engine oil and install at the top of the separator bowl.
11. Install (screw) separator bowl onto the filter head, hand tighten, then turn an additional  $\frac{3}{4}$  turn only.
12. Reconnect the fuel heater and the 'water-in-fuel' to their respective wiring harness.
13. Turn the ignition key switch to the ON position to energize the fuel supply shut-off solenoid valve.
14. Prime the fuel system using the hand primer until fuel spills out the metal vent plug.
15. Close the vent plug.
16. Start the engine and check for leaks. Refer to STARTING ENGINE in SECTION 2.

#### WARNING

To lower the risk of causing accidental fires, Do not leave fuel or oil soaked rags laying around.

#### WARNING

Drain fuel filter into a container and dispose of all fluids properly.



### FUEL HEATER



200555

A Fuel Filter/Water Separator  
B Fuel Heater (Bottom of Clear Bowl)

The fuel heater is incorporated into the fuel filter/water separator and is controlled electronically by the engine ECU.

**DIESEL EXHAUST FLUID (DEF) TANK**



A DEF Tank Fill Cap

The DEF tank is located in the compartment beside the boom saddle. The DEF tank fill cap can be accessed by lifting the hinged lid on top of the compartment. The DEF tank fill point is equipped with a strainer to prevent contaminants from entering the tank. Do not remove this strainer when filling the DEF tank.

DEF tank capacity is 43L (11.4 US gal). Do not overfill tank. This tank is equipped with an expansion capacity of 7% required to allow for the expansion of DEF in cold temperature conditions. DEF freezes at -11°C (12°F).

A DEF level indicator is shown on the main menu of the computer display, below the fuel gauge.

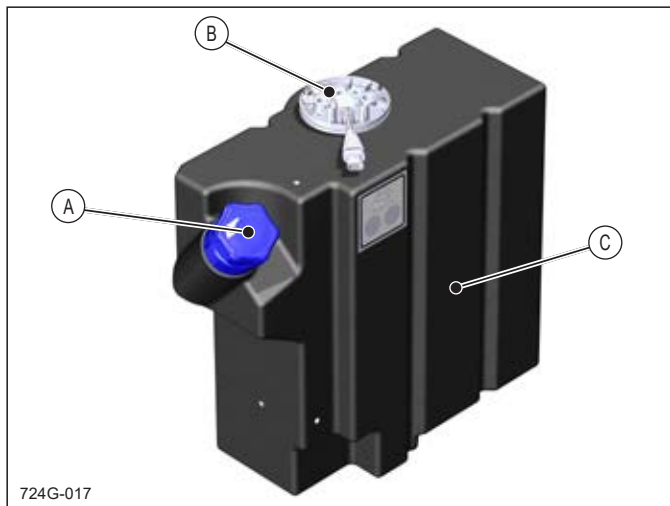

A DEF Tank  
 B Fill Cap/Strainer  
 C Sending Unit

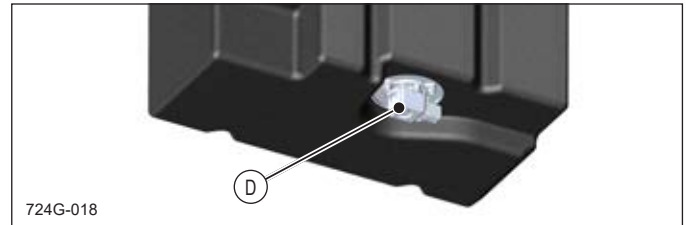

D DEF Quality Sensor

The DEF tank includes a fill cap/strainer, a sending unit and DEF quality sensor.

**SENDING UNIT**

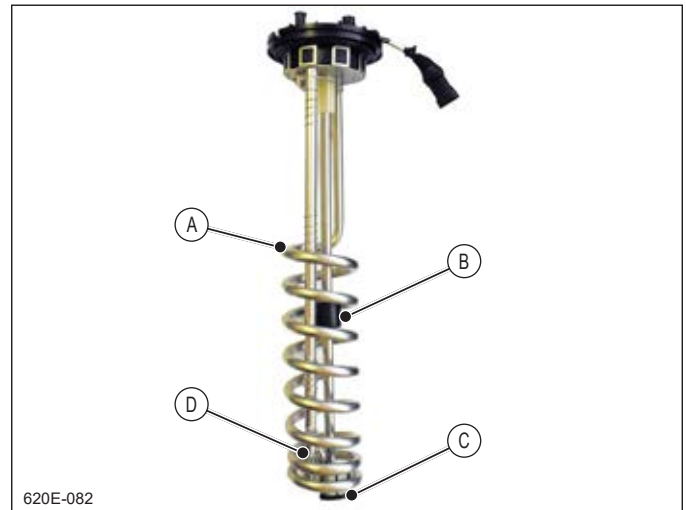

A Coolant Heater Coil  
 B Level Sensor  
 C Strainer  
 D Temperature Sensor

The sending unit incorporates a heater coil, vent port, level sensor, strainer, temperature sensor, heating system inlet/outlet connections, DEF inlet/outlet connections and an electrical connector.

**DEF QUALITY SENSOR**



The DEF quality sensor is located on the bottom of the DEF tank. It must be removed to drain the tank.

**DEF DOSING MODULE FILTER**

The DEF dosing module filter should be replaced as part of scheduled maintenance every 250 hours.

If DEF and/or aftertreatment fault codes have occurred then Tigercat recommends performing a DEF flushing test and Urea Dosing System Test (UDST) at every DEF dosing module filter change to ensure proper operation of the DEF supply module.

If no DEF and/or aftertreatment fault codes have occurred then only the DEF dosing module filter replacement is required.

**CHANGING DEF DOSING MODULE FILTER, DEF FLUSHING TEST AND UDST (UREA DOSING SYSTEM TEST)**

**TOOLS REQUIRED**

- 27 mm (1 1/16 in) wrench
- Container to catch DEF and flushing water
- Clean distilled/demineralized water
- 1 litre (0.25 US gal) plastic water bottle with hose attached\*
- Laptop computer with Tigercat by FPT E.A.SY. engine diagnostic software to run UDST test\*
- PT-Box\*

**IMPORTANT!**

Do not contaminate the DEF when performing maintenance on the system as this may cause costly damage to SCR system components and affect the proper operation of the aftertreatment system and the engine.

\*Items required if performing a DEF flushing test and UDST.

**REMOVE DEF DOSING MODULE FILTER**

1. Park the machine on level ground. Refer to PARKING THE MACHINE in SECTION 1.  
**NOTE:** Verify that engine is at operating temperature before turning OFF the engine.
2. Wipe clean the area around the DEF supply module and filter including the supply module ports with particular attention to the inlet port and filter cap to avoid introducing contamination into the filter housing while performing this procedure.
3. Place container below to catch the spills.

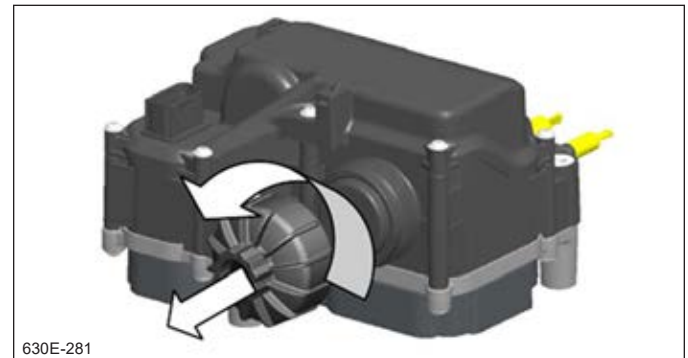

4. Turn the filter cover counterclockwise to remove from the supply module. Use a 27 mm (1 1/16 in) wrench.



5. Remove the equalizing element and note the colour of the filter inside (black or grey).

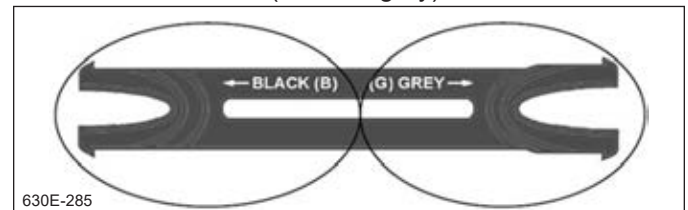

6. Find the filter removal tool provided with the replacement parts select the correct edge BLACK (B) for black filters or GREY (G) for grey filters.

**MACHINE START-UP**

**IMPORTANT!**

Before beginning this procedure, perform the PRE-STARTUP AND FILLING procedure outlined in THIS SECTION.



A Emergency Stop Switch

1. Push DOWN the emergency stop switch to prevent the engine from starting.



A 'G' Charge Pressure Test Port

2. Connect a 70 bar (0–1000 psi) pressure gauge on the swing pump 'G' test port to check charge pressure. Observe the gauge closely.



**WARNING**

**Machine operator must only take directions from the person doing the set-up.**

3. Turn ignition key switch to the ON position, lower the left armrest and press and release the pilot interlock reset switch. This will allow oil to circulate and refill the pilot and case drain circuits during the following cranking procedure.

4. Turn ignition key switch to RUN position.
5. Crank engine for five seconds, then wait for five seconds.

Check the swing charge pressure gauge during cranking to observe for pressure reading. Repeat five times to pump oil into pumps and system components.

**NOTE:** If charge pressure gauge does not indicate a rise in pressure, check for possible cause (air in system, leaks, loose hose fittings, pumps not turning, etc.). Repair problem. Repeat steps 3, 4 and 5 until a rise in charge pressure is noticed.

6. Turn the emergency stop switch clockwise to allow it to pop up to turn machine power ON.

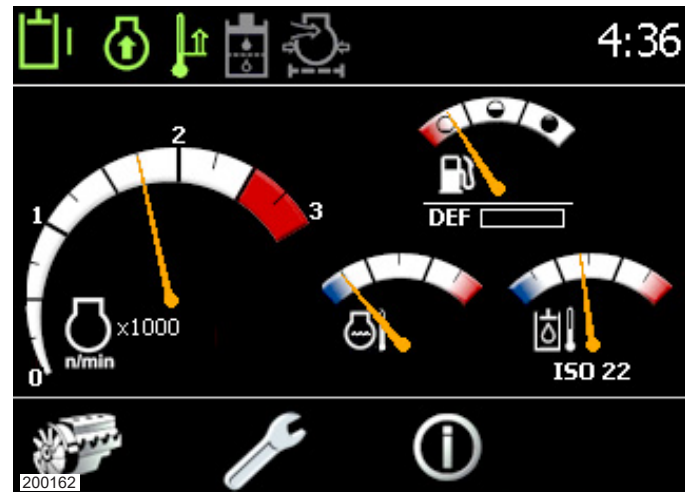

7. Turn ignition key switch to RUN position and observe the computer display. Wait for the screen to display the gauges before starting the engine.
8. Start the engine and press and release the pilot interlock reset switch.

If charge pressure does not rise within 20–30 seconds, turn OFF the engine.

If charge pressure is between 18–31 bar (260–450 psi), run the engine at LOW speed for 20 minutes. Check the engine oil pressure on the computer display. Refer to COMPUTER–ENGINE MENU in SECTION 2. Do not operate any functions.

**REMOVAL OF ANTI-CORROSION SPRAY  
(IF APPLICABLE)**

Some machines, particularly machines shipped outside North America, are shipped with an optional anti-corrosion spray to protect the machine from corrosion during shipment.

This anti-corrosion spray should be removed when the machine reaches its destination as it may cause debris to stick to the treated surfaces of the machine.

The anti-corrosion spray can be removed with a pressure washer, a sponge and soap.

CLICK HERE TO **DOWNLOAD** THE COMPLETE MANUAL

- Thank you very much for reading the preview of the manual.
- You can download the complete manual from: [www.heydownloads.com](http://www.heydownloads.com) by clicking the link below



- Please note: If there is no response to CLICKING the link, please download this PDF first and then click on it.

CLICK HERE TO **DOWNLOAD** THE COMPLETE MANUAL

# Tigercat 250D Loader

## SECTION 4–HYDRAULIC SYSTEM

---

Read and understand the entire contents of this manual, and all manuals for any attachments or accessories associated with this machine, prior to operating or servicing this equipment.

### CONTENTS–SECTION 4

ISSUE 1.1, DECEMBER 2018

CONTROL VALVES .....	4.8
AUXILIARY .....	4.23
CROSS SECTION .....	4.24
PORTS .....	4.23
MAIN .....	4.9
CROSS SECTION .....	4.11
PORT RELIEF AND ANTI-CAVITATION VALVE OPERATION .....	4.12
PORTS .....	4.9
ELECTRICAL COMPONENTS .....	4.36
GAUGE FITTINGS–TEST PORTS .....	4.37
HYDRAULIC OIL HEATING PROCEDURE .....	4.42
HYDRAULIC OIL TANK .....	4.3
HYDRAULIC SYSTEM CIRCUITS .....	4.4
MAIN CIRCUIT .....	4.4
PILOT CIRCUIT .....	4.4
SWING CIRCUIT .....	4.4
LOAD SENSING .....	4.26
BASIC PRINCIPLES .....	4.26
CIRCUIT COMPONENTS–EARLIER DESIGN .....	4.30
CIRCUIT COMPONENTS–LATER DESIGN .....	4.32
CIRCUIT SCHEMATIC–EARLIER DESIGN .....	4.31
CIRCUIT SCHEMATIC–LATER DESIGN .....	4.33
OPEN-CENTRE VS CLOSED-CENTRE .....	4.27
OPERATING TIPS .....	4.29
PRESSURE LIMITING CONTROL .....	4.34
PRESSURE LIMITING CONTROL .....	4.34
PRESSURE SETTINGS .....	4.37
SET LOAD SENSE RELIEF VALVE .....	4.40
SET MARGIN PRESSURE .....	4.38
PUMPS .....	4.5
MAIN .....	4.6
SWING .....	4.6
SAFETY PRECAUTIONS .....	4.37, 4.42

MAIN VALVE SPOOL CROSS SECTION

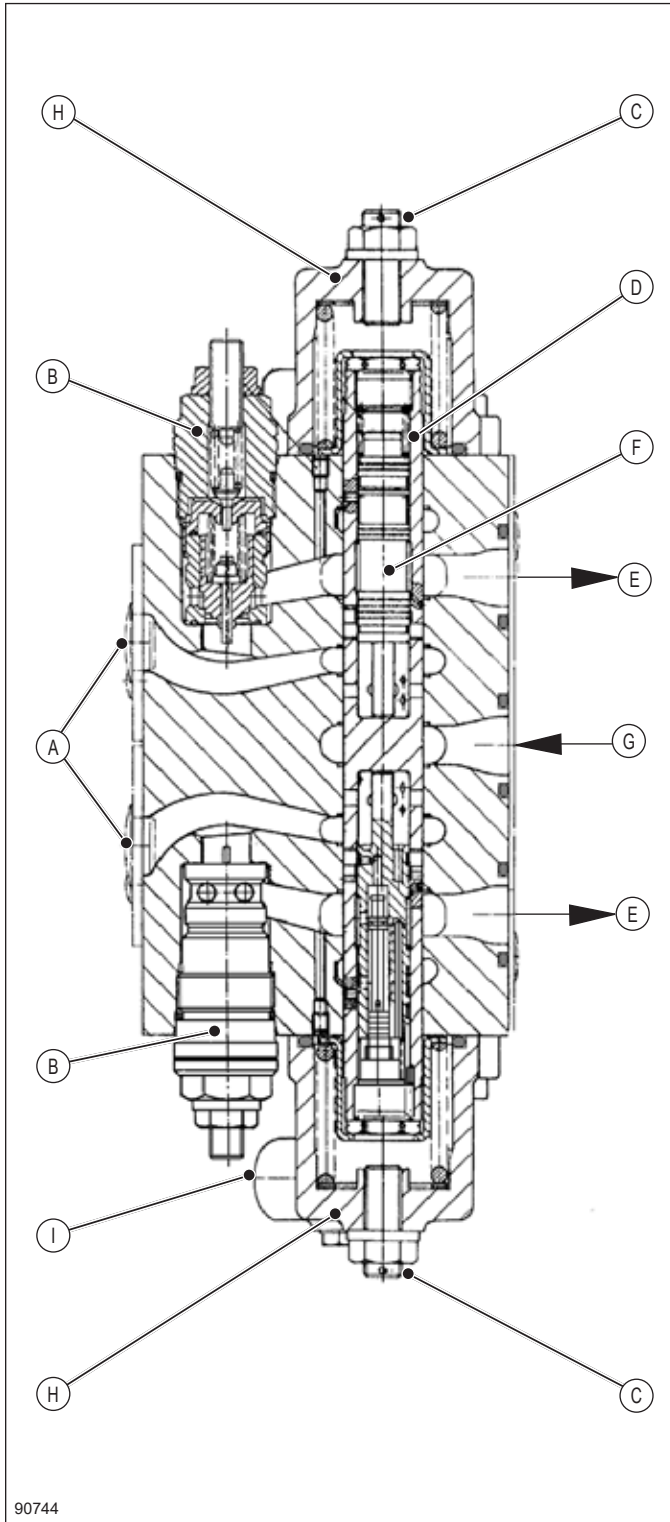

No-Flow Position

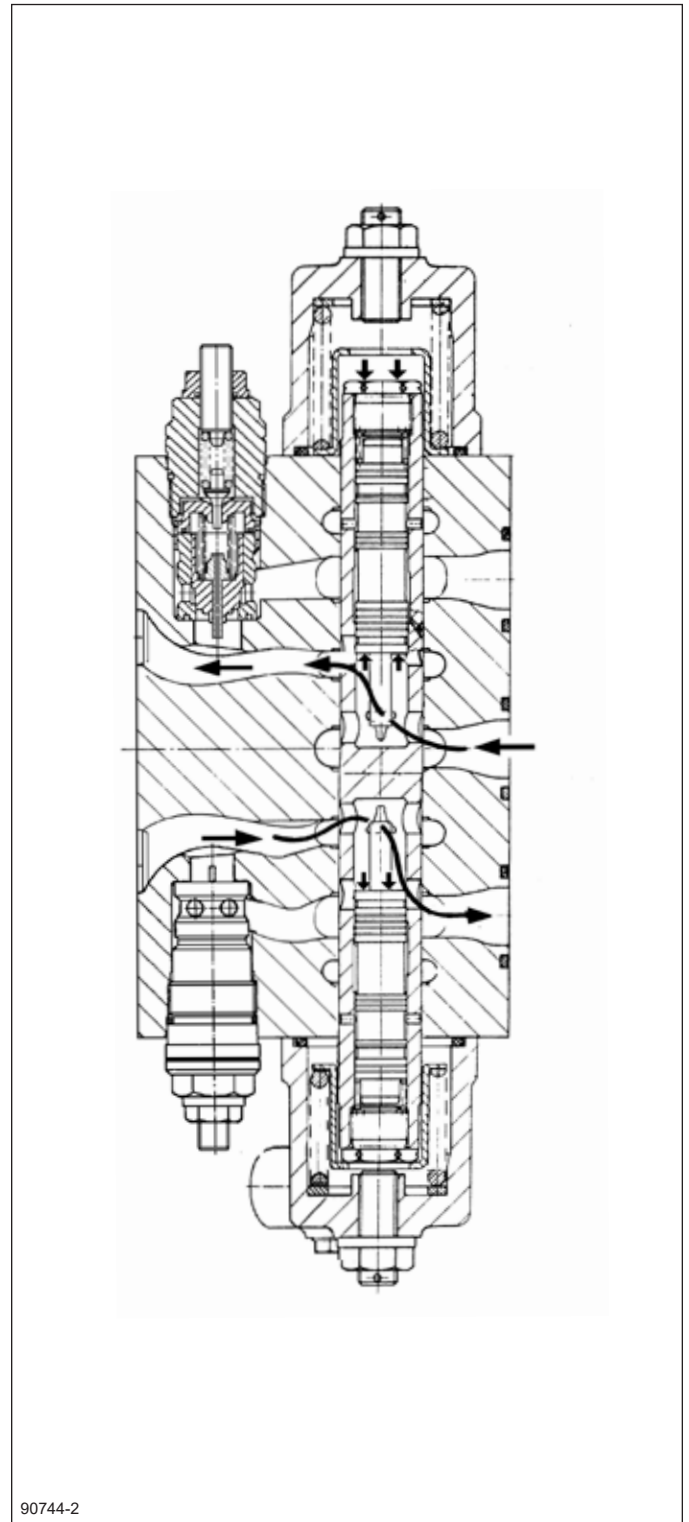

Flow Position

Main Valve Section—Typical Cylinder-Operated Functions

- |   |  |
|---|--|
| <ul style="list-style-type: none"> <li>A Work Ports</li> <li>B Port Relief (Anti-Cavitation Valve)</li> <li>C Spool Travel Adjusting Screw</li> <li>D Load Sensing 'LS' Valve</li> <li>E Return 'T' Port</li> </ul> | <ul style="list-style-type: none"> <li>F Pressure Compensator Valve</li> <li>G 'P' Port—From Main Pump</li> <li>H Pilot End Cap</li> <li>I Return Pilot Check</li> </ul> |
|---|--|

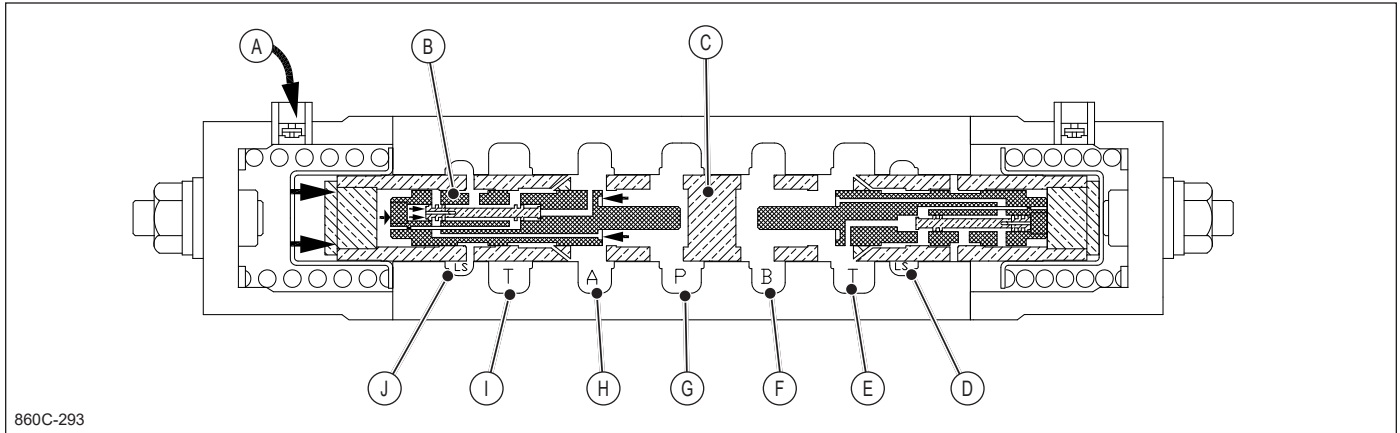

(I) Control Valve Section

A Pilot Oil	F 'B' Work Port
B Compensator Valve settles in Balance location	G Supply Passage 'P' (Pump Discharge)
C Control Spool fully shifted to right	H 'A' Work Port
D Load Sensing 'LS' Passage	I 'T' Tank Port Return
E 'T' Tank Port Return	J Load Sensing 'LS' Passage

Control valve section (I):

- Control spool fully shifted to right
- Lower working pressure

As the control spool continues to move, the compensator spool continues to move in response to the pressure variations and it settles in a position of balance as shown in the figure with the spool fully shifted. As the loads vary in the 'WORK' ports, the valve components continue to modulate and compensate for the load variations and maintain movement of the selected functions.

This valve system automatically performs the functions performed by an operator using a conventional system.

If the second valve being operated had a higher work port pressure than the one already selected, the operation would be the same up to the point where the 'WORK' port was opened. At this point the 'LS' would change to the new higher work port pressure and the new valve would act in the same way as the first valve selected and described above. The first valve selected would then have the internal spool components take the same positions as the lower work port pressure valve described above.

LOAD SENSING SYSTEM CIRCUIT SCHEMATIC 2502161-2503129

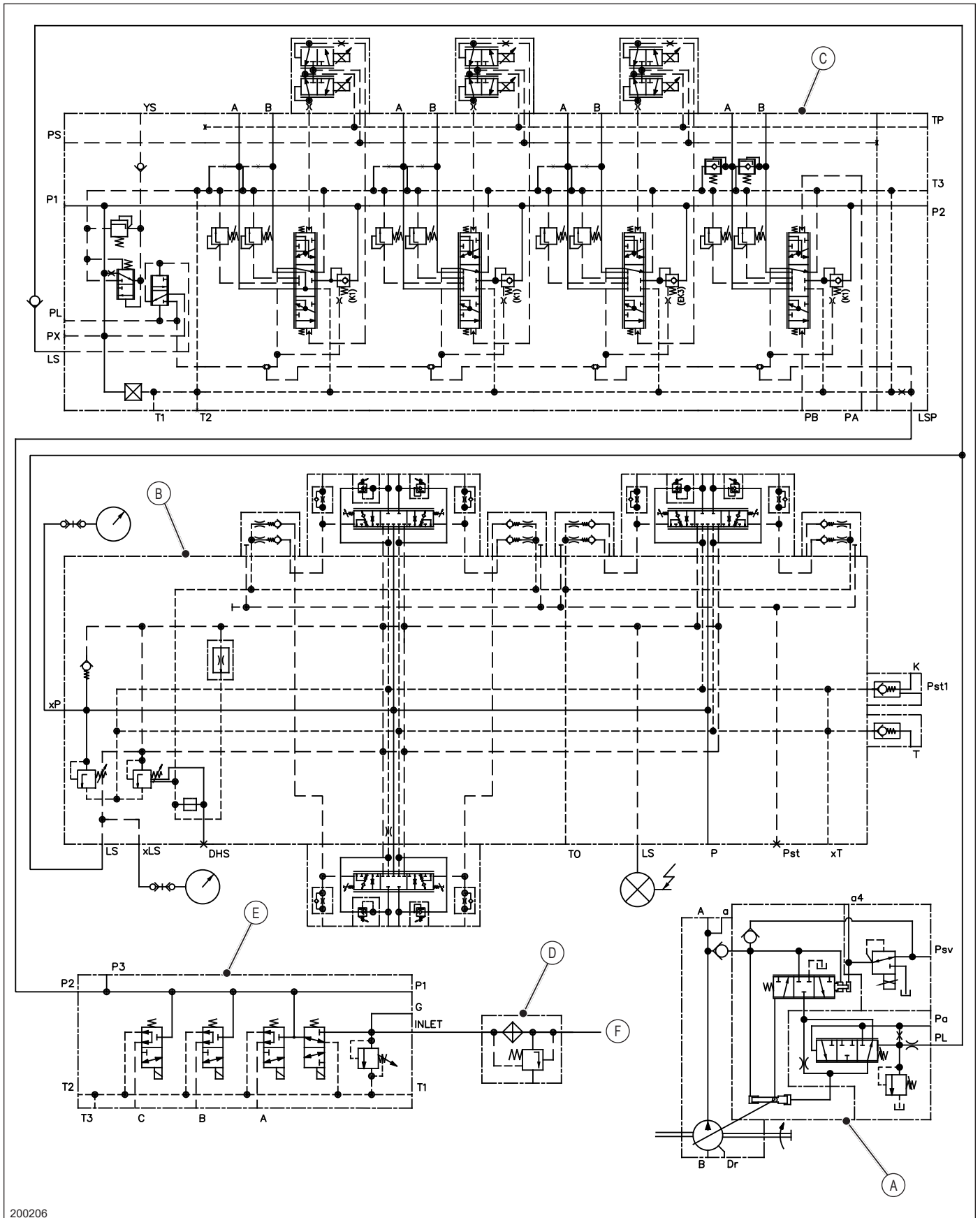

200206

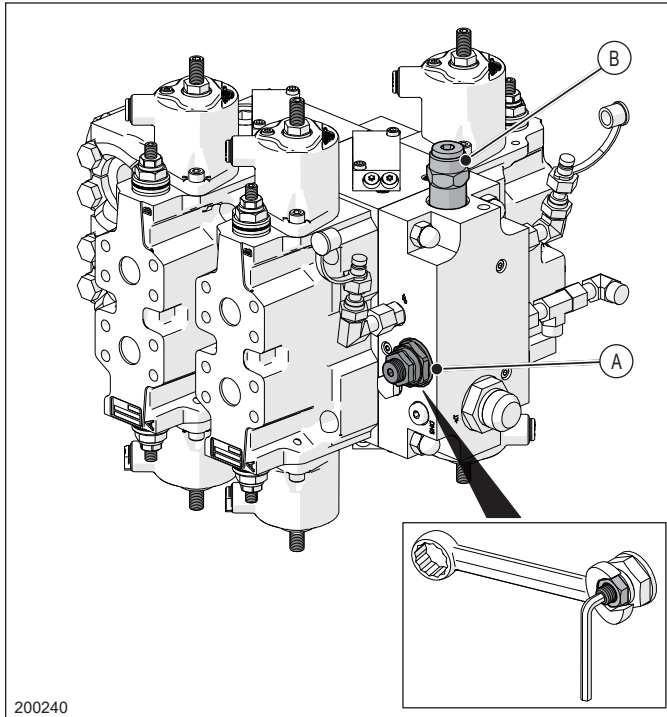

200240

- A Load Sense 'LS' Relief Valve Adjusting Screw  
 B Safety Relief

### MAIN VALVE SAFETY RELIEF

**NOTE:** The safety relief located at the top of the main valve is preset. **DO NOT ADJUST.** A roll pin is installed in the hex of the adjustment screw to identify that it is not to be adjusted.

10. With the aid of an assistant, hold the stick boom joystick in the OUT position (fully extended).
11. Loosen the load sense relief valve adjusting screw locknut and slowly turn the load sense relief valve adjusting screw until the pressure gauge reads Main Valve–Load Sense Relief specifications. Turn IN to increase pressure or turn OUT to decrease pressure. Hold the locknut with a 1-1/16 in wrench while using a 6 mm hex key to turn the adjusting screw.
12. Hold the adjusting screw in position with the hex key and retighten the locknut.
13. Recheck the pressure reading.
14. Set engine speed at LOW.
15. Turn OFF the engine and remove the gauge. Wipe up any spilled oil.

**PILOT MANIFOLD**

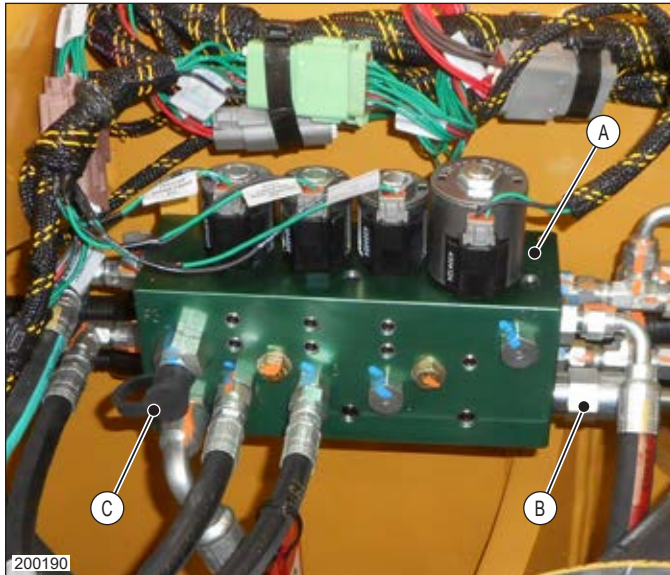

200190

- A Pilot Manifold
- B Pilot Relief Valve
- C Gauge Test Port

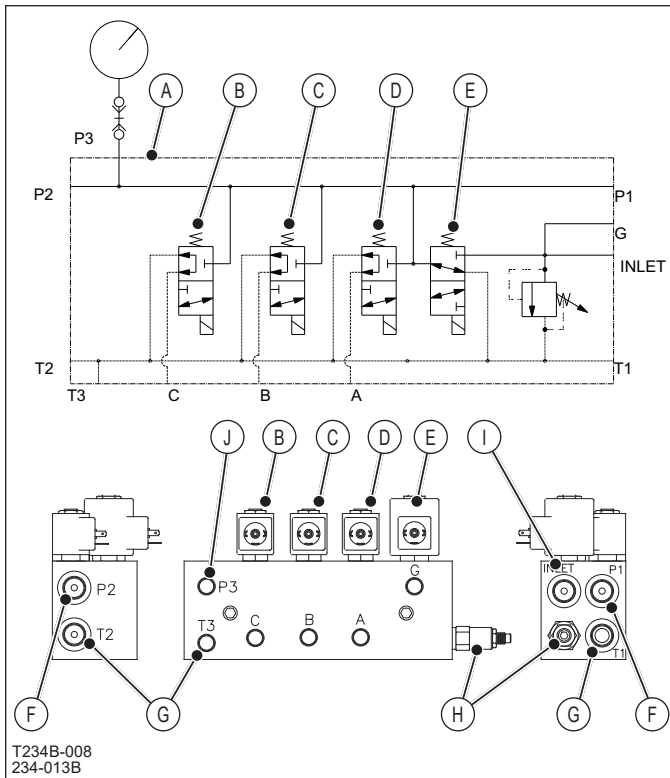

T234B-008  
234-013B

- A Pilot Manifold Hydraulic Schematic
- B Spare
- C Delimber Open/Hold
- D Spare
- E Pilot Shut-Off
- F To Auxiliary Valve 'PS', Joysticks, Swing Pedal, Cooler Bypass
- G Return Oil Ports
- H Pilot Relief Valve
- I Inlet
- J 'P3' Test Port

The pilot manifold is located below the platform in the hydraulic valve compartment.

The pilot manifold distributes oil through multiple ports. Ports 'P1', 'P2' and 'P3' are supplied pilot oil when the pilot shut-off valve is activated. Ports 'A', 'B' and 'C' are supplied pilot oil when the pilot shut-off valve and the corresponding solenoid valve are activated.

The pilot manifold distributes oil to the following circuits:

- Joysticks—port 'P1'
- Load Sense Pilot supply to auxiliary valve—port 'P2'
- Pilot Supply to auxiliary valve—port 'P2'
- Swing Control Valves—port 'P1'
- Oil Cooler Bypass Valve—port 'P2'
- Gauge Test Port—port 'P3'

Pilot oil enters the manifold through the inlet port.

The pilot shut-off valve is an integral part of the pilot manifold and controls the flow of oil from the inlet port to the outlet ports labelled 'P1', 'P2', 'P3' and to the solenoid operated pilot valves. The pilot shut-off valve is activated by lowering the left armrest and pressing the pilot interlock reset switch in cab.

Outlet port 'P1' feeds the hydraulic joysticks. Outlet port 'P2' feeds the auxiliary valve 'PS' port, the swing control valves, the oil cooler bypass valve and the load sense pilot supply to the 'LSP' port on the auxiliary valve. Gauge test port 'P3' has a quick connect fitting installed for connecting a pressure gauge to perform pressure setting procedures.

Three solenoid-operated pilot valves on the manifold supply 'on demand' pilot oil to the corresponding functions when energized. These valves are activated by controls in the cab.

Two tank ports 'T1' and 'T2' collect oil from all pilot controls. Tank 'T3' port drains the return oil to the tank via the case drain strainer.

**FUSE AND RELAY PANEL – CAB**

The cab fuse and relay panel is located below the main display control panel behind a removable cover.

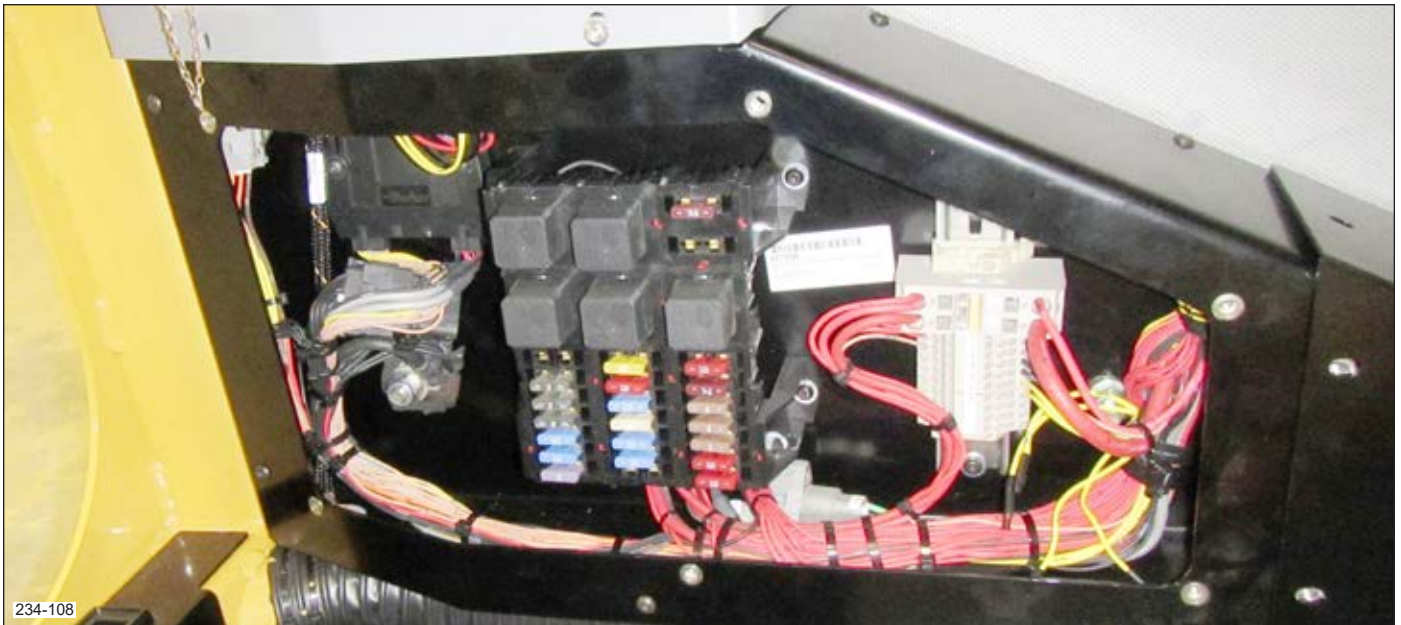

234-108

24	26	1. <input type="text" value="7.5A"/>
		2. <input type="text" value="15A"/>
25	27	28
3. <input type="text" value="2A"/>	10. <input type="text" value="20A"/>	17. <input type="text" value="10A"/>
4. <input type="text" value="2A"/>	11. <input type="text" value="10A"/>	18. <input type="text" value="7.5A"/>
5. <input type="text" value="2A"/>	12. <input type="text" value="15A"/>	19. <input type="text" value="5A"/>
6. <input type="text" value="2A"/>	13. <input type="text" value="25A"/>	20. <input type="text" value="5A"/>
7. <input type="text" value="15A"/>	14. <input type="text" value="15A"/>	21. <input type="text" value="5A"/>
8. <input type="text" value="15A"/>	15. <input type="text" value="15A"/>	22. <input type="text" value="10A"/>
9. <input type="text" value="3A"/>	16. <input type="text" value="10A"/>	23. <input type="text" value="10A"/>

**FUSES**

1. TANK VACUUM
2. HARVESTER COMPUTER (IF EQUIPPED)
3. TELEMATICS
4. IQAN SWITCHES
5. JOYSTICK GRIP
6. XC21-A2/A3
7. XA2-A1 /HARVESTER (IF EQUIPPED)
8. XA2-A0
9. MD3
10. CONVERTER
11. SERVICE LIGHT / ENGINE DIAGNOSTIC
12. HORN
13. HVAC
14. WORK LIGHTS - CAB
15. WORK LIGHTS - BOOM
16. WORK LIGHTS - REAR
17. AIR RIDE SEAT (IF EQUIPPED)
18. SEAT HEAT / COOL
19. HVAC CONTROL
20. KEY INPUT
21. PILOT RESET
22. TRACK / STABILIZERS
23. WIPER / WASHER

**RELAYS**

24. WORK LIGHTS - REAR (IF EQUIPPED)
25. WORK LIGHTS - CAB
26. HVAC
27. WORK LIGHTS - BOOM
28. ACCESSORIES
29. PILOT ON (HARVESTER COMPUTER)

NOTE: IN-LINE FUSE IS LOCATED AT THE HVAC FAN SWITCH.

## COMPUTER CONTROL SYSTEM

The computer control system is comprised of the following components:

- Computer and Display Module
- XA2-A0 Expansion Module (under platform in valve compartment)
- XA2-A1 Expansion Module (engine compartment)
- XC21-A1 Expansion Module (cab main console)
- Engine Electronic Control Unit (ECU)
- Various controls, switches, sensors and valves not shown

The computer and display module is the main controller in the system. The computer program is the operating system for the computer and display module as well as the control system for the machine operating parameters.

The engine ECU provides electronic information to the computer via J1939 CAN bus links. The information is displayed on the computer display.

**NOTE:** The computer control system is software-based. This software may be updated after the machine is in service as a part of on-going product improvement programs and service newsletters. The information contained in this manual is accurate at the time of printing. Improvements to the machine and/or software are on-going and may not be covered. In these cases, contact your Tigercat dealer for appropriate information.

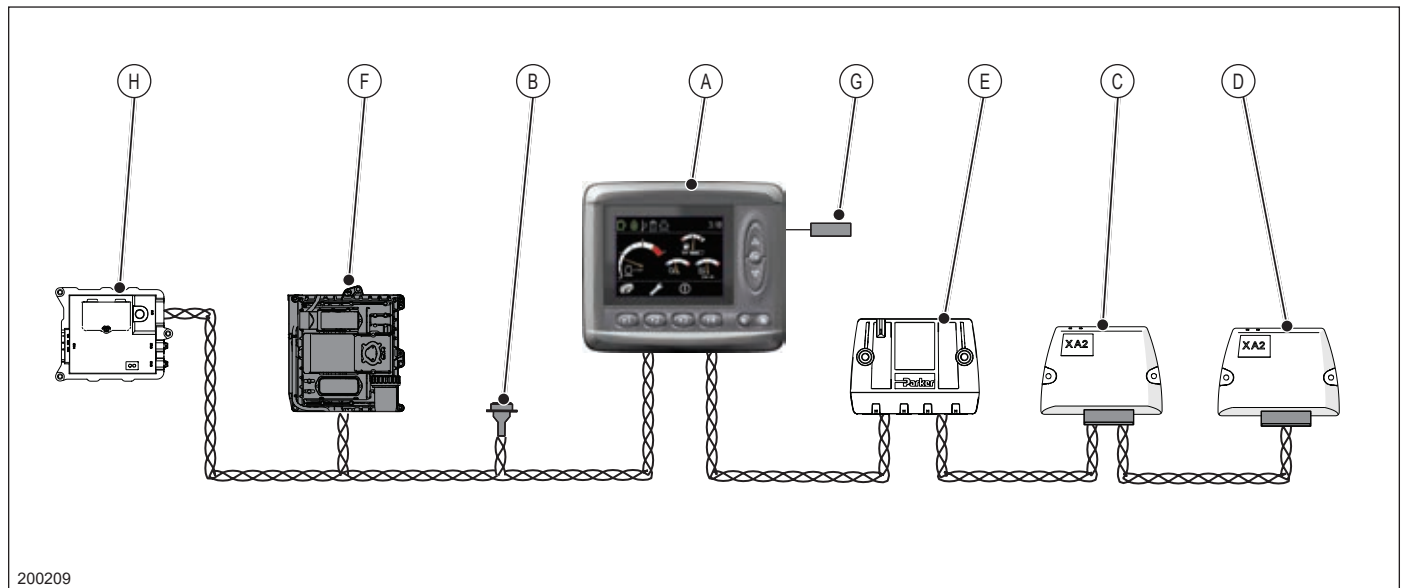

200209

### Computer Control System Components

A Computer and Display Module	E XC21-A2 Expansion Module (Cab Main Console)
B Engine Diagnostics Connection–19-Pin	F Engine Electronic Control Unit (ECU)
C XA2-A0 Expansion Module (Cab Electrical Compartment)	G USB Connection Port–Computer
D XA2-A1 Expansion Module (Behind Cab, Right Side)	H Telematics System Module

## IQAN PROGRAM SOFTWARE

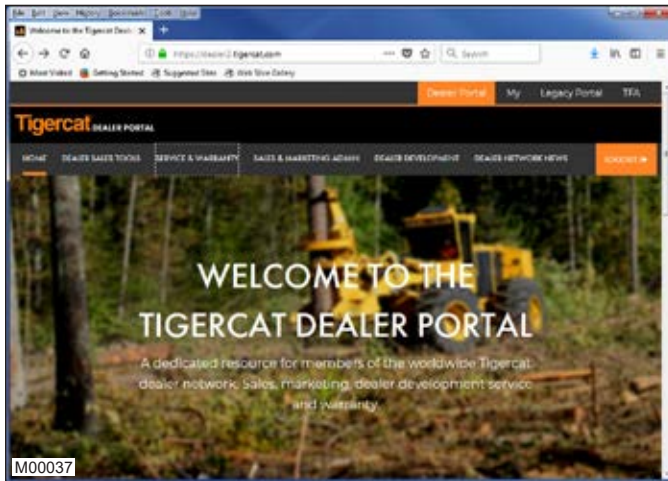

IQAN Active Studio 4 software can be downloaded from the Tigercat dealer website.

All software required for PC/laptop use and a user manual is included in this download. Some of the software requires a software key (available from Tigercat).

Contact Tigercat Customer Service for more information about specific hardware requirements for PC/laptop.

## DOWNLOAD INSTRUCTIONS

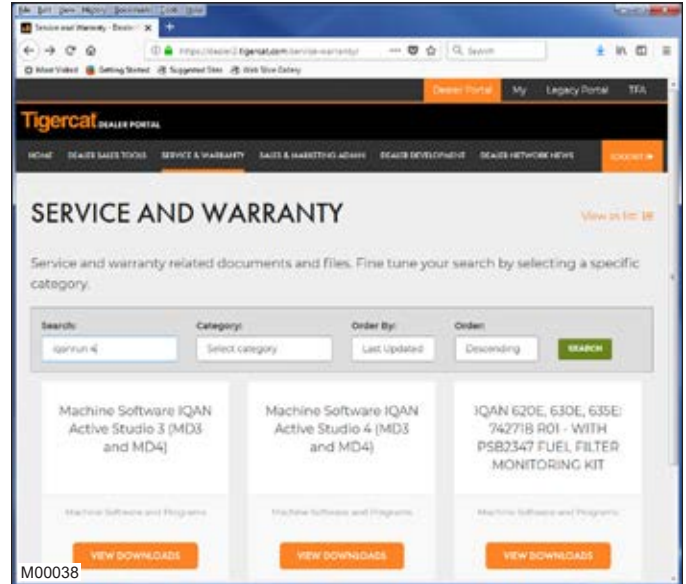

1. Enter IQANrun 4 in the Search box and click on SEARCH to find Machine Software IQAN Active Studio 4 (MD3 and MD4).
2. Click on VIEW DOWNLOADS.

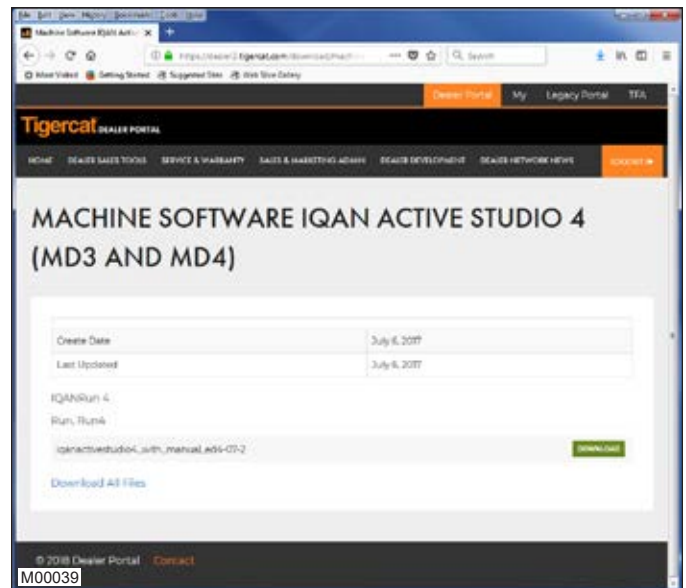

3. Click on DOWNLOAD.
4. The IQAN software file has now been downloaded to the downloads folder on your PC/laptop.

MEASURE (GRAPH)

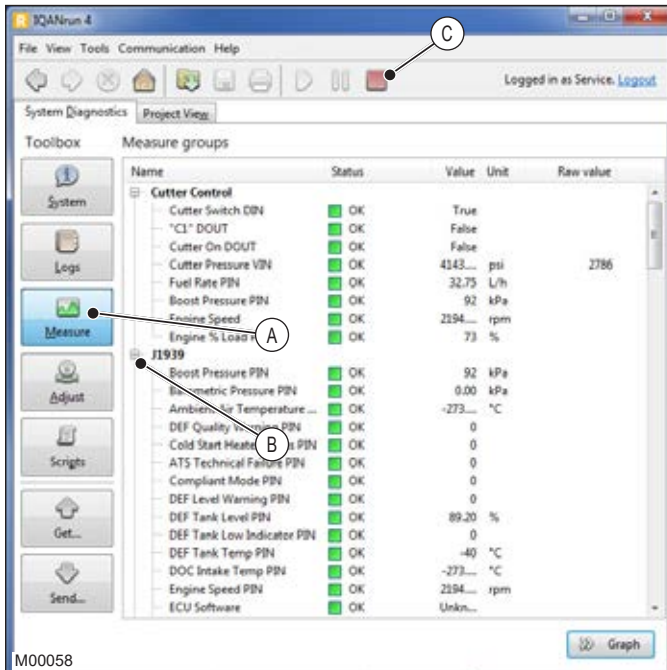

M00058

- A Click 'Measure'
- B Click '+' to Expand
- C Click the 'Stop' button

1. Click the 'Measure' button on the left.

All of the measure groups available will be shown on the right.

Each group can be expanded to view the channels in the groups.

2. To graph the channels in a measure group, double-click the measure group and the graph will appear.

Individual channels can be shown or hidden from the graph by clicking on the check box to the left of each channel.

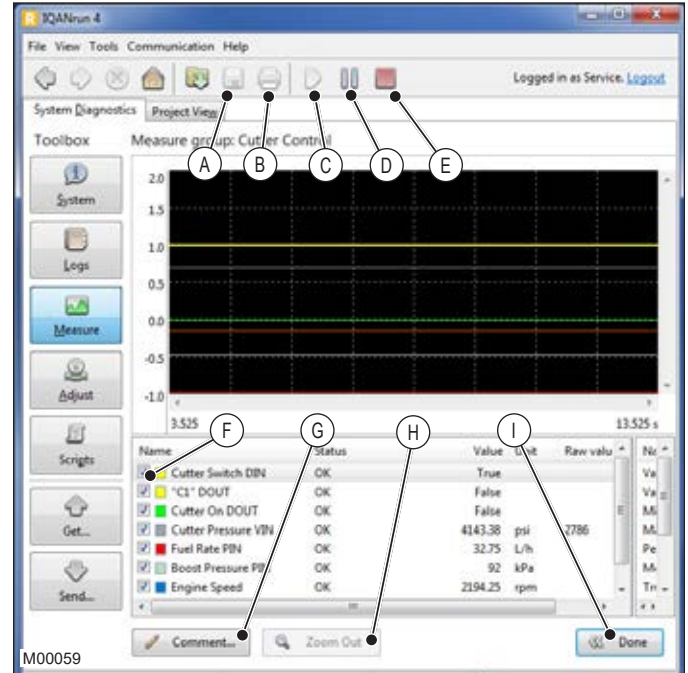

M00059

- A 'Save' Button
- B 'Print' Button
- C 'Green Arrow' Button To Start Measuring
- D 'Pause' Button To Pause Measuring
- E 'Red Square' Button To Stop Measuring
- F Check Box
- G 'Comment...' Button
- H 'Zoom Out' Button
- I 'Done' Button

3. Click:
  - a. The 'Green Arrow' button to start measuring,
  - b. The 'Pause' button to pause the graph illustration while continuing to measure, or
  - c. The 'Red Square' button to stop measuring.
4. Click the 'Comment...' button to add comments to the measure file at any time.
 

The measure file data must be saved (\*.irm3) to retain comments for later viewing.
5. Click the 'Red Square' button to stop measuring and access the zoom function.
6. Select an area of the graph to zoom in and view in more detail. Click the 'Zoom Out' button to return to the full graph view.
7. Click the 'Red Square' button to stop measuring and access save function.
8. Click the 'Save' button to save the 'Measure' data as a \*.irm4 file.
9. Click the 'Red Square' button to stop measuring and access print function.
10. Click the 'Print' button to print the graph and data recorded.

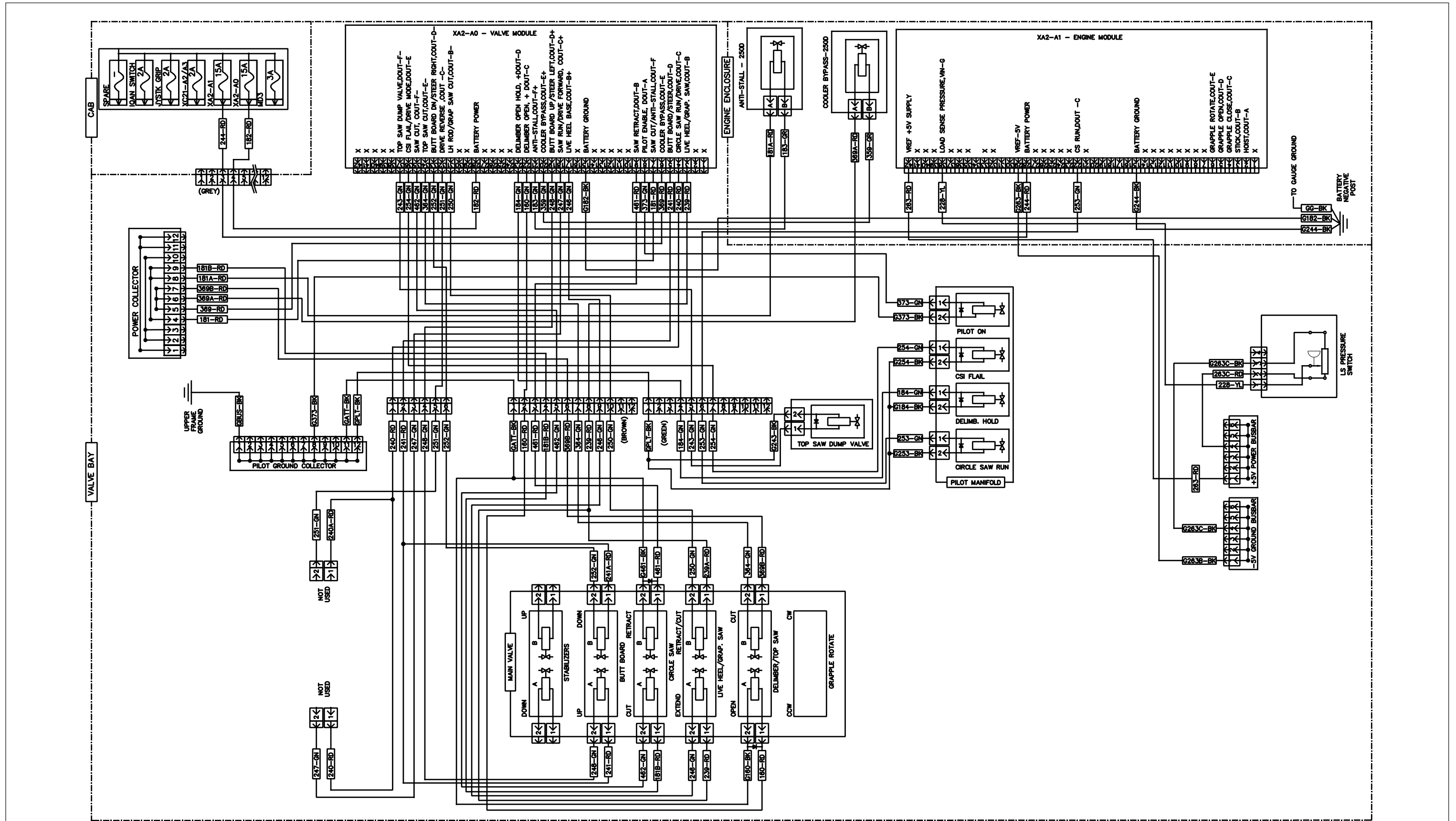

70771B00

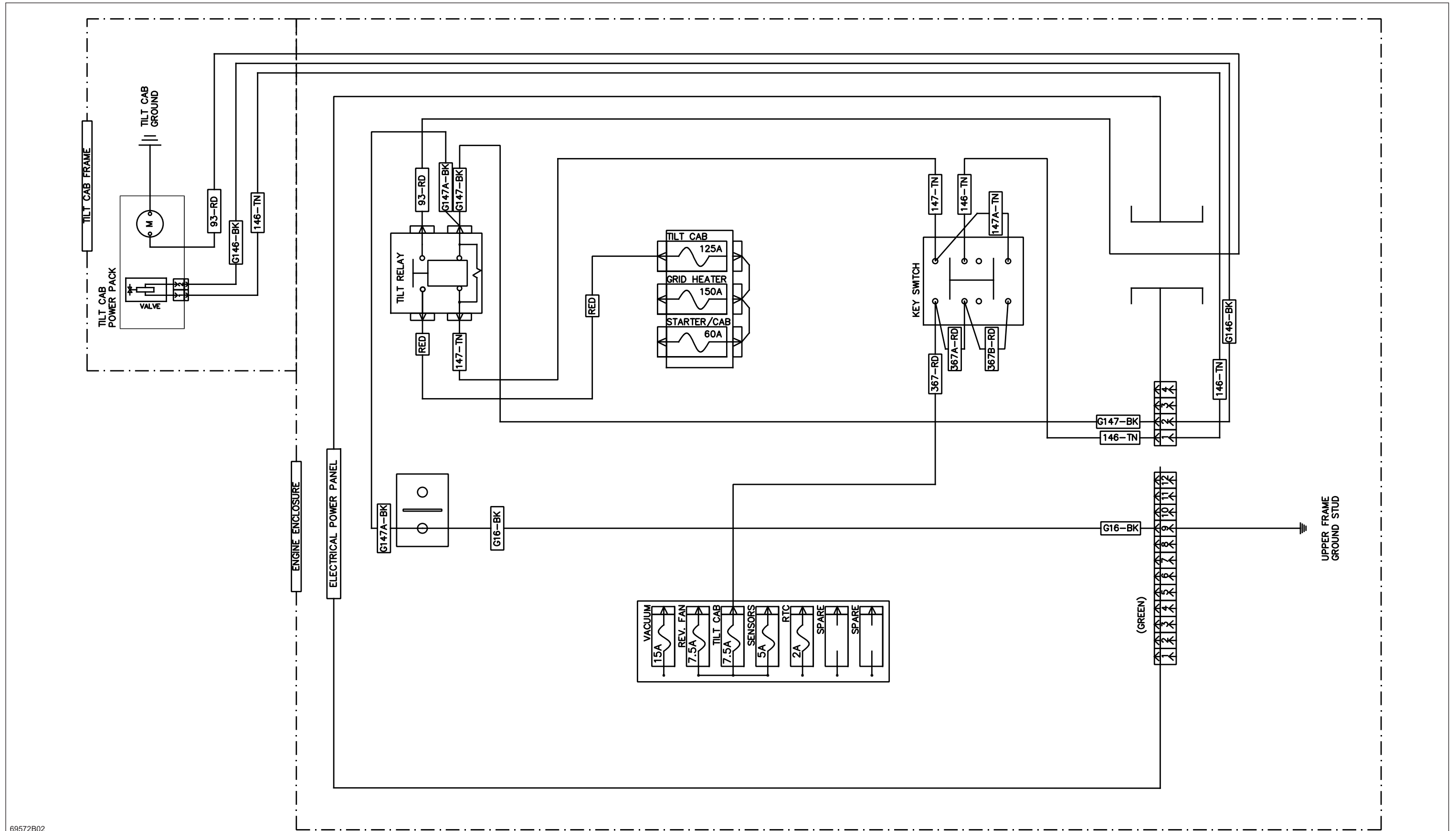

69572B02

Electrical Schematic-Tilt Cab Power Pack

## ENGINE

This machine is equipped with a Tigercat FPT N67 6.7 L diesel engine. This engine can be provided in both Tier 2 and Tier 4f configurations.

Refer to engine OPERATION AND MAINTENANCE MANUAL Part No. 45045AMUL (Tier 2) or Part No. 42939AMUL (Tier 4f) for complete details.

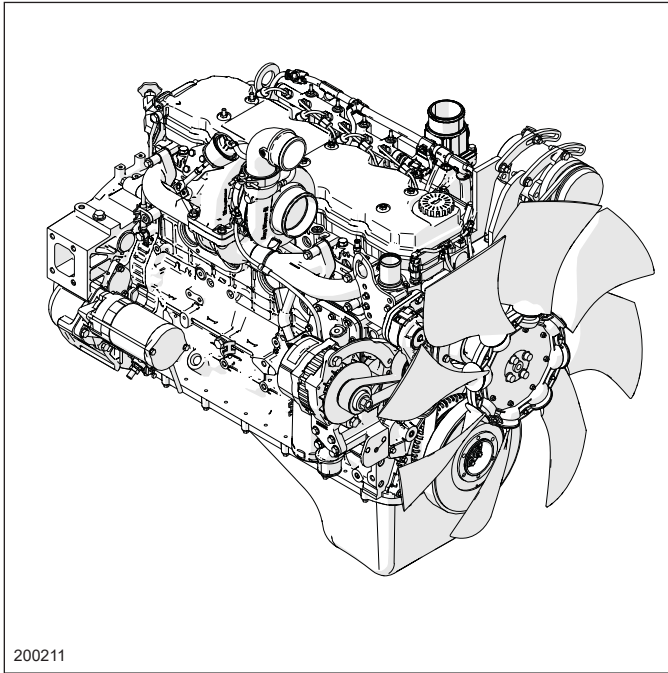

Engine—Earlier Design—Compressor at Front

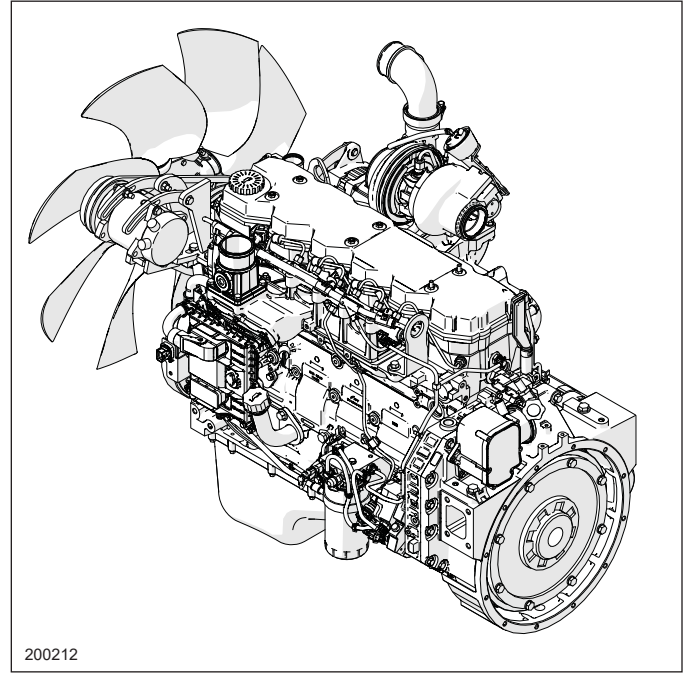

Engine—Earlier Design Compressor at Front

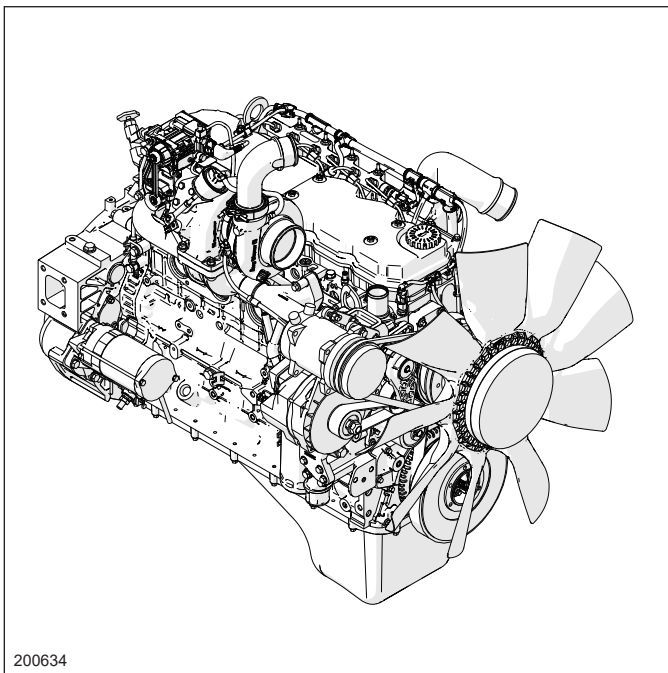

Engine—Later Design—Compressor at Rear

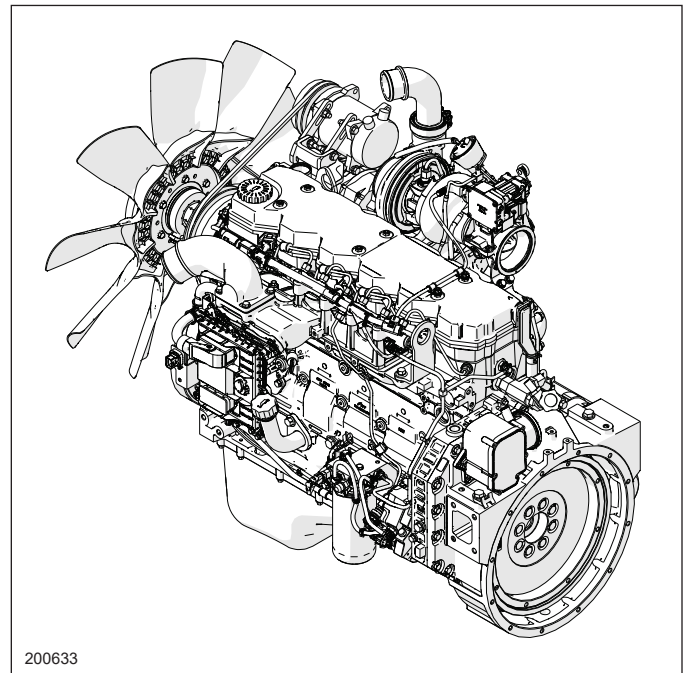

Engine—Later Design—Compressor at Rear

## ELECTRICAL POWER TO PUMP CONTROL VALVE SOLENOID

When the anti-stall is ON an electrical signal is sent to the pump control valve solenoid from the computer through the XA2-A0 expansion module. The signal is current output. The signal value varies from 600mA at LOW engine speed to 0 mA at HIGH engine speed.

**NOTE:** The pump controller is controlled based on hydraulic oil temperature along with the engine load. The pump will be variably de-stroked until the hydraulic oil temperature is in operating range.

1. Remove wire connector from main pump control solenoid.

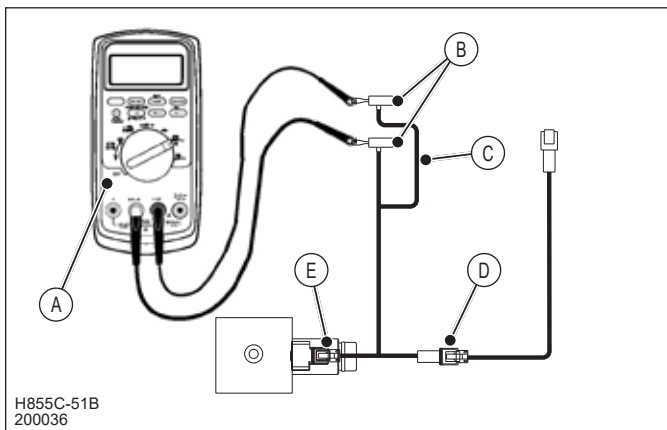

- |   |   |
|---|---|
| A | Multimeter                                  |
| B | Banana Plugs to Fit Multimeter              |
| C | Diagnostic Break-Out Harness                |
| D | Machine Wire Harness                        |
| E | Main Pump Anti-Stall Control Valve Solenoid |

2. Plug in a diagnostic break-out harness 20036B (part of Tigercat electrical kit 20045B) to the solenoid plug and wire harness connector.
3. Connect a multi meter to the banana plugs of the break-out harness. Set multi meter to current flow selection.
4. Start engine and confirm that anti-stall is ON. Set engine speed at LOW. Meter reading should be 600 mA.
5. Set engine speed at HIGH. Meter reading should be (0 mA).

**NOTE:** When the computer senses a drop in engine speed the signal to the valve will increase proportionally, this will allow pilot oil to flow to the 'Pf' port on the pump to destroke the pump and provide anti-stall.

## COMPUTER AND XA2 EXPANSION MODULE TEST

Refer to XA2 MODULES in SECTION 6 for test procedures.

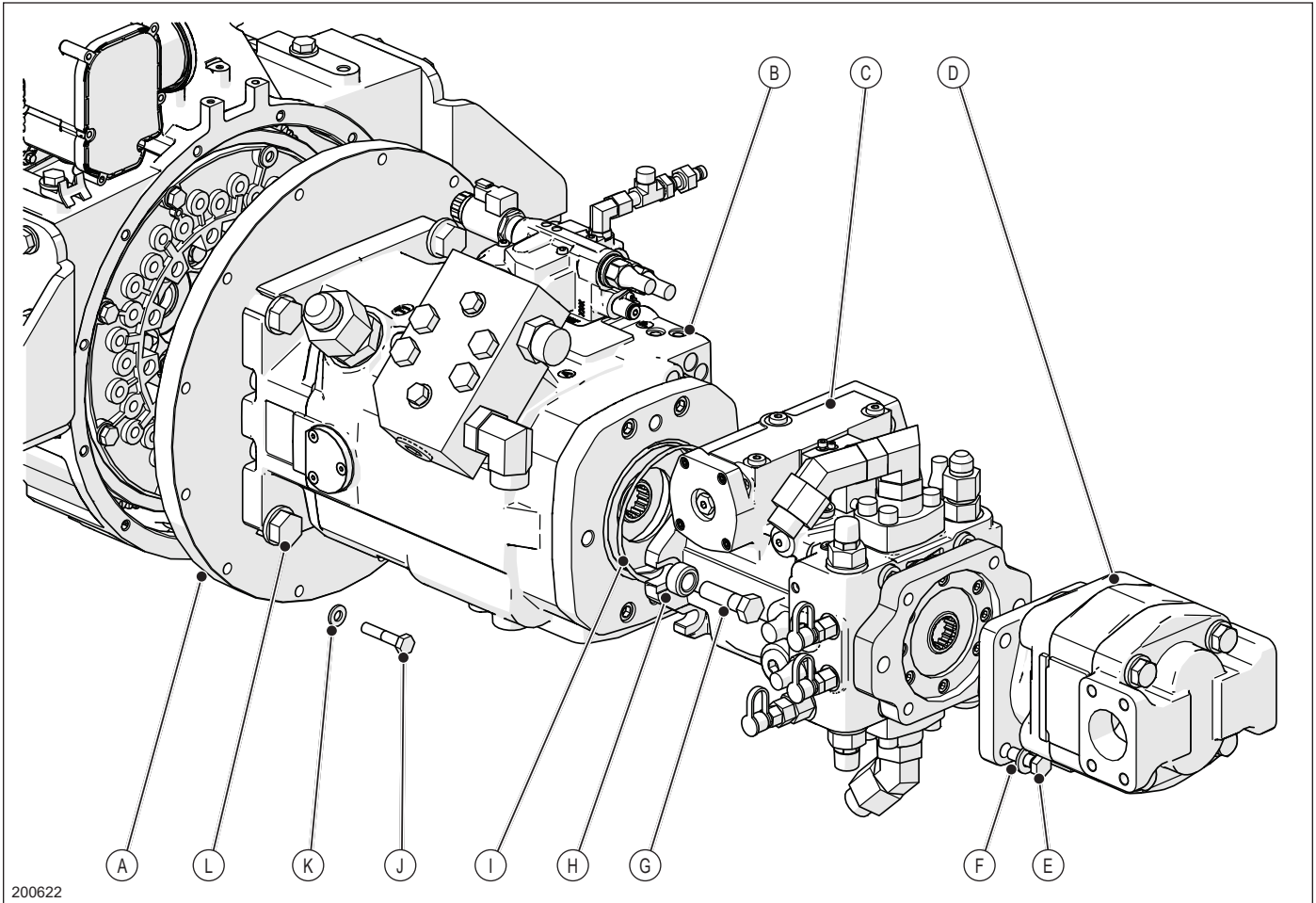

200622

- |   |   |
|---|---|
| <ul style="list-style-type: none"> <li>A Pump Mounting Plate</li> <li>B Main Pump</li> <li>C Swing Pump</li> <li>D Saw Pump (When Equipped)</li> <li>E Hex Head Bolt—M12-1.75X35 (Qty 4)</li> <li>F Washer—M12 or 1/2 inch (Qty 4)</li> </ul> | <ul style="list-style-type: none"> <li>G Hex Head Bolt—M16-2.0X55 (Qty 2)</li> <li>H Spacer Part No 11167A (Qty 2)</li> <li>I O-ring—Main Pump to Swing Pump</li> <li>J Hex Head Bolt—M10-1.5X50 (Qty 12)</li> <li>K Washer—M10 or 3/8 inch (Qty 12)</li> <li>L Hex Head Bolt—M20-2.5X60 (Qty 4)</li> </ul> |
|---|---|

5. Mount swing pump to main pump.
  - a. Install a new O-ring in the groove on the main pump.
  - b. Apply Blue 243 Loctite® to two M16-2.0X55 hex head bolts.
  - c. Install bolts with two swing pump bolt spacers (part no 11167A).
  - d. Torque bolts to 224 N-m (165 lbf-ft).
6. Mount saw pump (when equipped) to swing pump.
  - a. Apply Blue 243 Loctite® to four M12-1.75X35 hex head bolts.
  - b. Install bolts with zinc plated M12 or 1/2 inch hard flat washers.
  - c. Torque bolts to 102 N-m (75 lbf-ft).
7. Mount pump mounting plate/pump stack to engine.
  - a. Apply Blue 243 Loctite® to twelve M10-1.5X50 hex head bolts.
  - b. Install bolts with zinc plated M10 or 3/8 inch hard flat washers.
  - c. Torque bolts to 61 N-m (45 lbf-ft).
8. Tighten main pump to pump mounting plate bolts.
  - a. Torque the four M20-2.5X60 hex head bolts to 508 N-m (375 lbf-ft).
9. Recheck engine crankshaft end play.

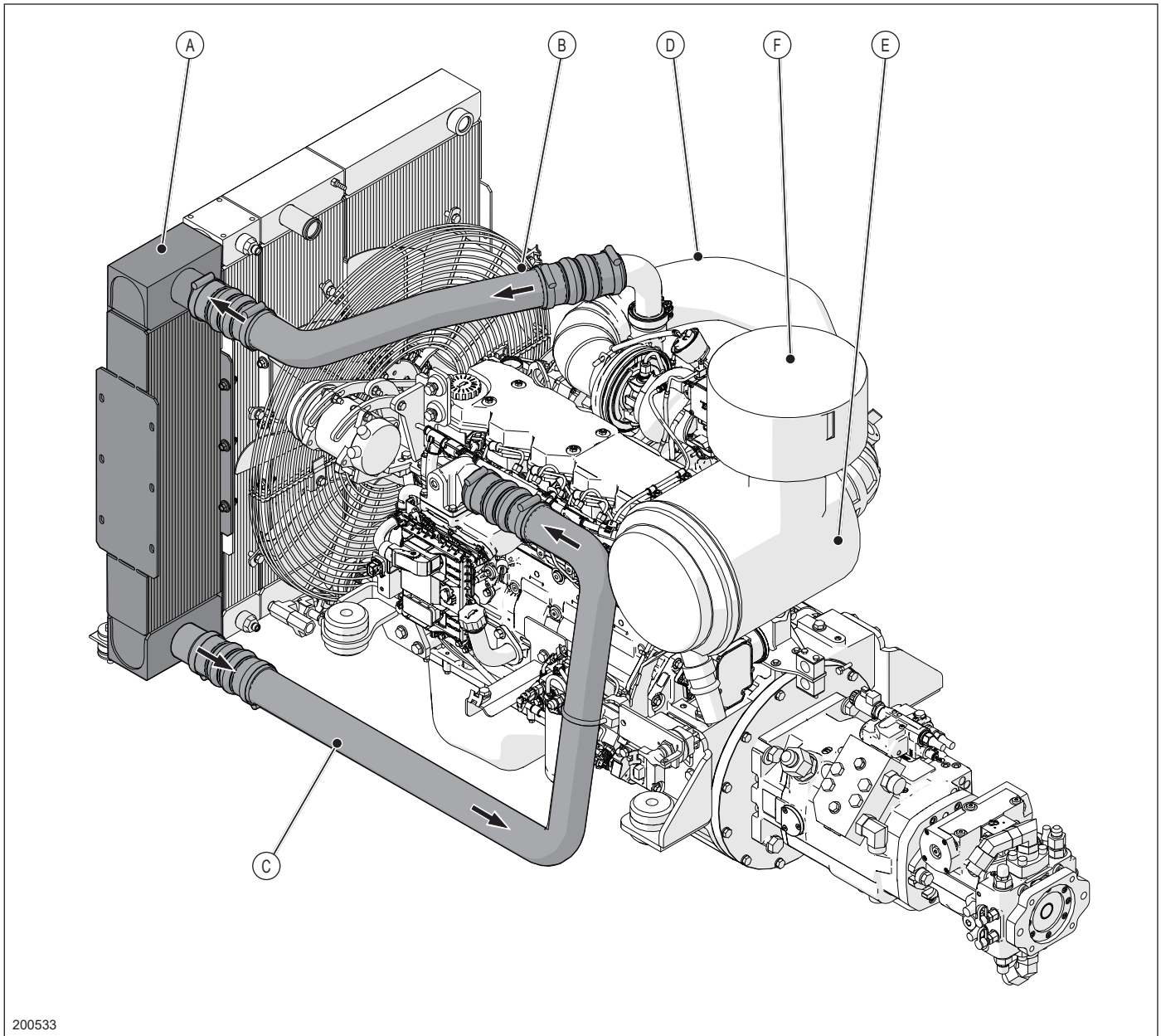

200533

**2503130-2504000**

- |  |                                   |
|--|-----------------------------------|
| A Charge Air Cooler Core                             | D Air Intake Tube to Turbocharger |
| B Charge Air Tube-Turbocharger to Charge Air Cooler  | E Air Cleaner                     |
| C Charge Air Tube-Charge Air Cooler to Engine Intake | F Air Precleaner                  |

The charge air cooler is the front core section of the cooler package.

HYDRAULIC OIL COOLER CIRCUIT SCHEMATIC 2502161-2503129

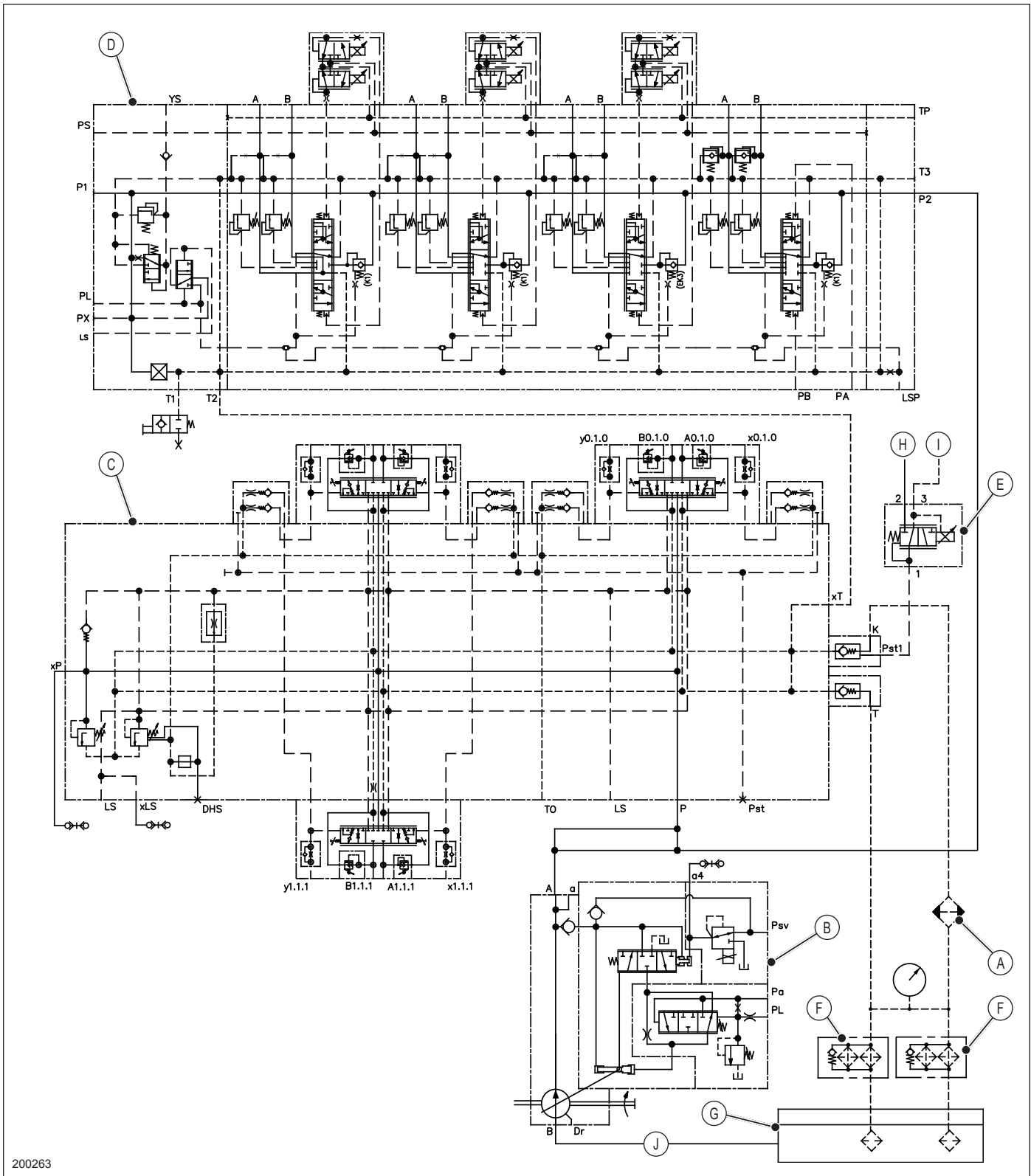

200263

- A Hydraulic Oil Cooler
- B Main Pump
- C Main Valve
- D Auxiliary Valve
- E Oil Cooler Bypass Valve

- F Hydraulic Oil Return Filters
- G Hydraulic Oil Tank
- H From Pilot Manifold 'P2' Port
- I To Pilot Manifold 'T2' Port
- J Suction Line-From Hydraulic Oil Tank

**DOSING MODULE**

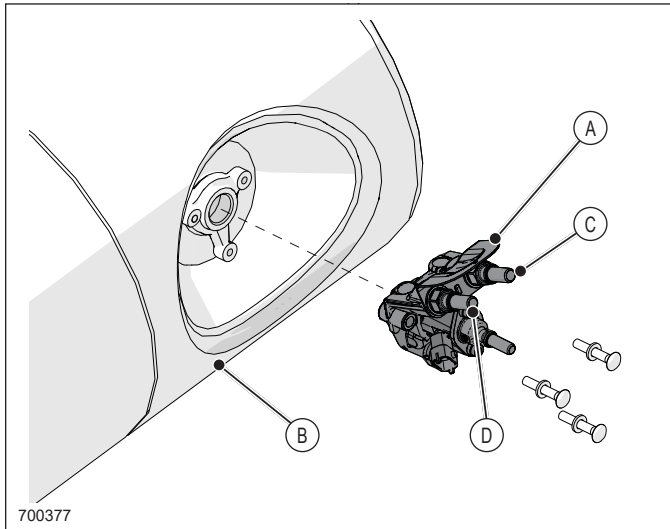

700377

- A Dosing Module (DEF Injector)
- B Diesel Oxidation Catalyst (DOC)
- C Coolant Inlet from Heater Valve
- D Coolant Outlet to Radiator

The dosing module is mounted directly to the diesel oxidation catalyst, which operates at high temperatures. The dosing module's temperature is moderated by a constant flow of coolant, regardless of the coolant control valve position (open or closed).

**DEF TANK SENDING UNIT**

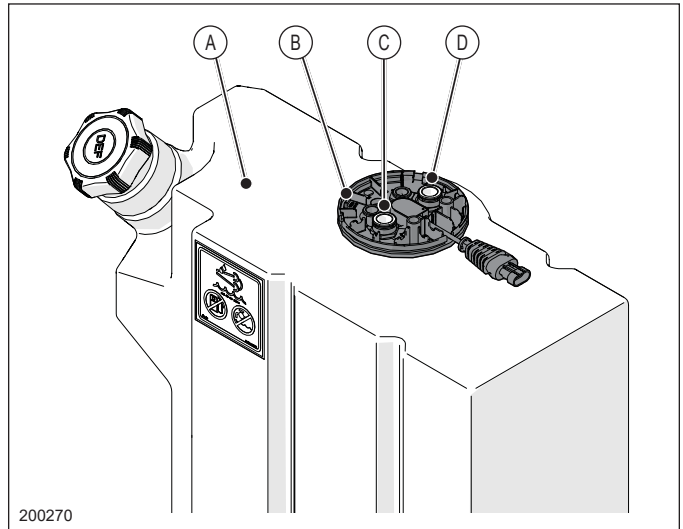

200270

- A DEF Tank
- B Sending Unit
- C Coolant Inlet from Heater Valve
- D Coolant Outlet to DEF Supply Module

The DEF tank sending unit is equipped with a coolant heater coil. When the temperature of the diesel exhaust fluid or ambient air falls below a specified threshold, the sensor relays a signal to the engine ECU. The ECU energizes the solenoid on the coolant control valve, switching the valve to the open position. Coolant is diverted through the heating element inside the DEF tank, warming the diesel exhaust fluid.

**JOYSTICKS—LEFT AND RIGHT**

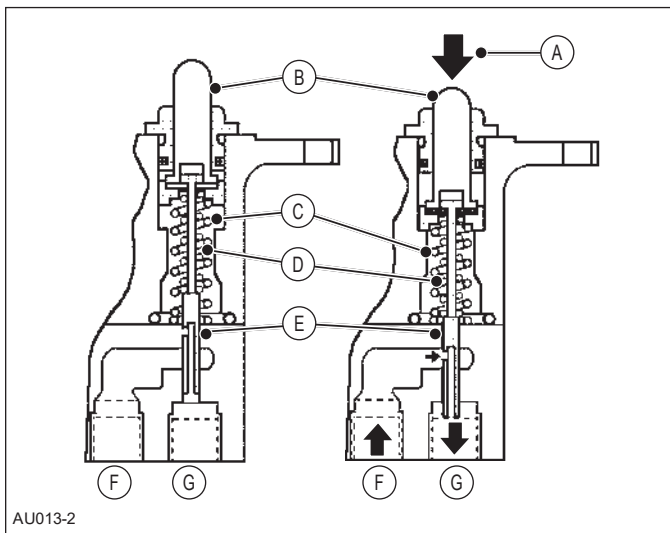
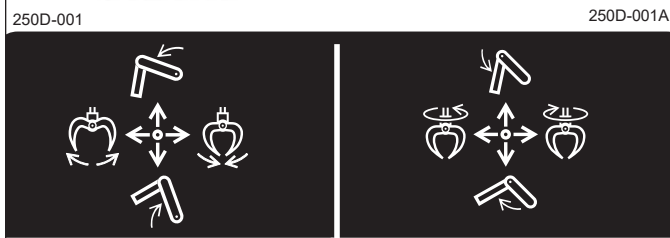

AU013-2

**Joystick Pilot Valve Spool Arrangement**

- A Lever Operation
- B Plunger
- C Return Spring
- D Regulating Spring
- E Spool
- F 'P' Port
- G Work Ports ('1' and '3')

The boom joystick pilot valves are a manually operated directional control valve and operate on the same principle as a direct-operating pressure-reducing valve. Operated by hand, this valve directs pilot pressure to the main valve pilot end caps. The corresponding spool valve then shifts from its center position and directs pump flow to operate the corresponding cylinder(s).

**OPERATING DESCRIPTION**

In the neutral position, the joystick lever is held centered by the return spring.

When the joystick is operated, the plunger is pushed against the return spring. At the same time, the spool is moved through the regulating spring.

When the regulating stroke begins, there is a connection from port 'P' via the channel in the spool and work ports '1' or '3' in the base of the valve, to the main valve pilot end caps.

Pressure provided by the main pump via the pilot manifold at work ports '1' and '3' of the joystick valve is directly proportional to the operator position of the joystick and the regulating spring characteristic.

Moving the left joystick back will raise the main boom UP and moving the joystick forward will lower the main boom DOWN.

Moving the right joystick back will push the stick boom OUT and moving the joystick forward will pull the stick boom IN.

# Tigercat 250D Loader

## SECTION 15–SWING

---

Read and understand the entire contents of this manual, and all manuals for any attachments or accessories associated with this machine, prior to operating or servicing this equipment.

### CONTENTS–SECTION 15

ISSUE 1.1, DECEMBER 2018

CIRCUIT COMPONENTS .....	15.4
CIRCUIT SCHEMATIC .....	15.5
LENS PLATE TIMING ADJUSTMENT .....	15.16
PRESSURE SETTINGS.....	15.14
SET POR RELIEF VALVE.....	15.15
SET SWING RELIEF VALVES.....	15.14
SAFETY PRECAUTIONS .....	15.14, 15.16
SWING BEARING.....	15.18
ADJUST SWING BEARING BACKLASH .....	15.20
SEAL KIT INSTALLATION INSTRUCTIONS.....	15.19
WEAR LIMITS.....	15.18
SWING BRAKE.....	15.12
SWING DRIVE GEARBOX .....	15.11
SWING DRIVE SYSTEM.....	15.2
SWING MOTOR.....	15.10
CROSS SECTION .....	15.10
SCHEMATIC .....	15.10
SWING PUMP.....	15.7
CROSS SECTION .....	15.8
SCHEMATIC .....	15.9
T-BAR FOOT CONTROL–SWING .....	15.13

**SWING DRIVE GEARBOX**



200117

A	Swing Motor
B	Swing Brake (Optional)
C	Swing Drive Gearbox
D	Fill Plug–Swing Brake Housing (Optional)

Power is transmitted from the swing motor to a double reduction planetary gearbox. The swing drive gearbox upper gearing is lubricated by oil stored in a bottle attached to the inside of the gearbox cover. The oil bottle must remain half full at all times. Refer to SERVICE AND LUBRICATION POINTS in SECTION 3 for correct oil specification and maintenance schedule.

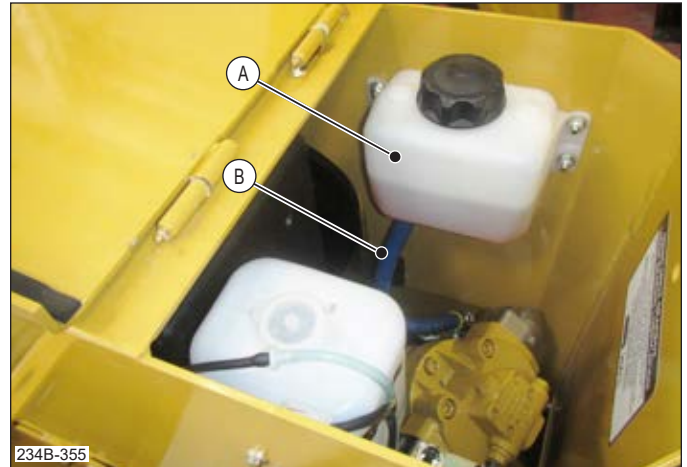

234B-355

A	Swing Drive Gearbox Oil Bottle
B	Hose to Gearbox

To fill the gearbox with oil–no swing brake:

1. Remove the cap on the bottle.
2. Add oil to the bottle until the bottle is half full.
3. Replace the cap on the bottle.

To fill the gearbox with oil–with swing brake:

1. Remove the fill plug on the swing brake housing.
2. Add oil until full and replace fill plug.
3. Remove the cap on the bottle.
4. Add oil to the bottle until the bottle is half full.
5. Replace the cap on the bottle.

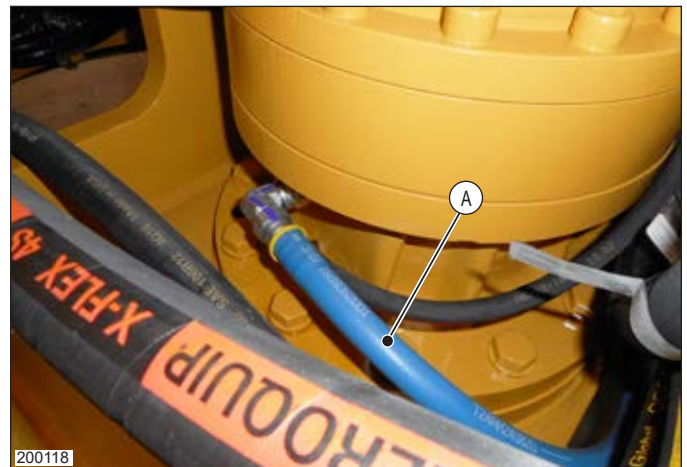

200118

A	Swing Drive Gearbox Oil Drain Hose
---	------------------------------------

To drain the gearbox, unscrew the drain hose plug and allow oil to drain into a suitable container. To facilitate draining, the oil should be warm.

# Tigercat 250D Loader

## SECTION 16–STABILIZERS

---

Read and understand the entire contents of this manual, and all manuals for any attachments or accessories associated with this machine, prior to operating or servicing this equipment.

### CONTENTS–SECTION 16

ISSUE 1.1, DECEMBER 2018

AUXILIARY VALVE .....	16.6
CIRCUIT COMPONENTS .....	16.4
CIRCUIT DESCRIPTION .....	16.3
CIRCUIT SCHEMATIC .....	16.5
CYLINDERS AND COUNTERBALANCE VALVES .....	16.7
PRESSURE SETTINGS.....	16.11
SET STABILIZER UP/DOWN PRESSURES .....	16.11
SAFETY PRECAUTIONS .....	16.11
STABILIZER ELECTRICAL SCHEMATIC.....	16.10
STABILIZERS	
LOWERING.....	16.3
RAISING.....	16.3

## PRESSURE SETTINGS

Before starting this procedure read the following safety precautions:

**NOTE:** Refer to SECTION 1 for more safety related information.

- Wear safety glasses and safety shoes.

### CAUTION

Use caution when in the cab as a slight touch of the controls can cause sudden rotation of the upper structure and boom.

### CAUTION

Be aware of other personnel in the area. Operator is responsible for the safe operation of the machine.

### WARNING

Make sure no one is standing near the grapple during this procedure.

**NOTE:** Keep the adjusting procedure brief. Constant loosening and tightening of the locknut (sealnut) on the adjusting screws will eventually cause the seal in the nut to break down and leak.

## SET STABILIZER UP/DOWN PRESSURES

Refer to PRESSURE AND SPEED SETTINGS and HYDRAULIC OIL OPERATING RANGE CHART in SECTION 3 for specific pressure and speed values.

### IMPORTANT!

During the following procedure, do not hold any function control over relief for longer than eight seconds. Wait five seconds to avoid overheating.

1. Park the machine on level ground. Refer to PARKING THE MACHINE in SECTION 1.
2. Warm the hydraulic oil to operating temperature. Refer to HYDRAULIC OIL HEATING PROCEDURE in SECTION 4.
3. Lower all four stabilizers to the ground.

### CAUTION

It may be necessary to lower all stabilizers to the end of the cylinder stroke in order to develop enough pressure to set the pressures.

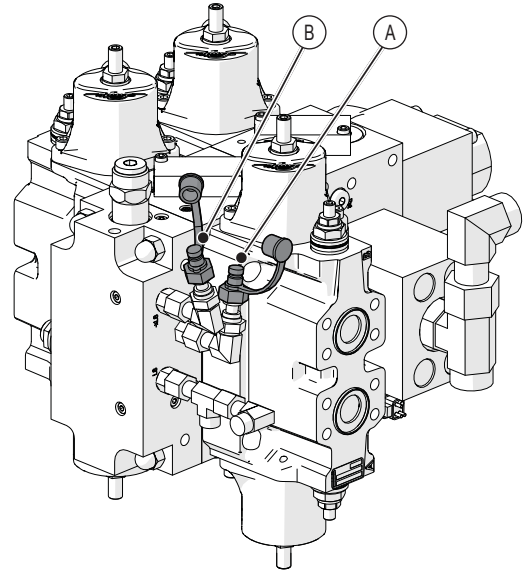

Main Valve—Earlier Design

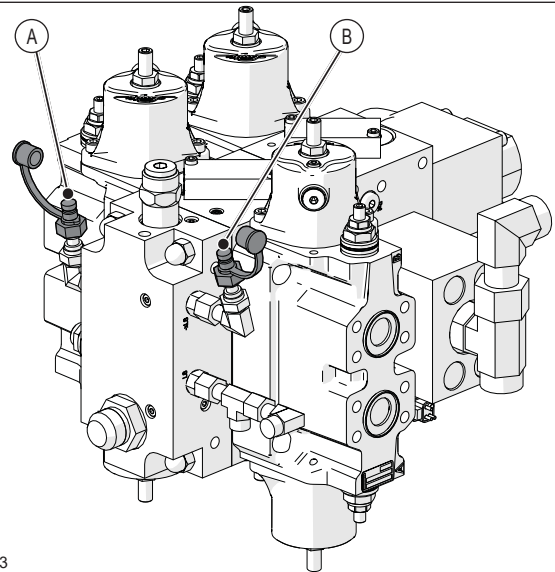

Main Valve—Later Design

- A 'xP' Test Port
- B 'xLS' Test Port

4. Connect a 350 bar (0–5000 psi) pressure gauge to the 'xLS' test port on the inlet section of the main valve.
5. Start the engine and set engine speed at LOW.
6. Lower the left armrest and press the pilot interlock reset switch to activate the pilot system.

### AUXILIARY VALVE

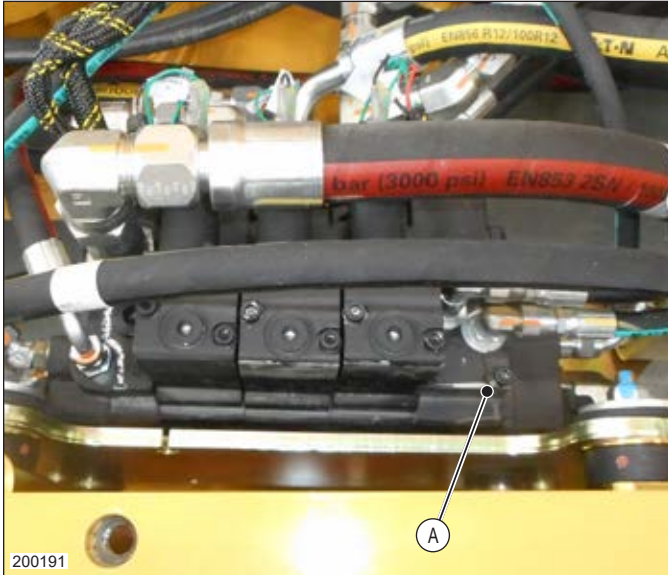

200191

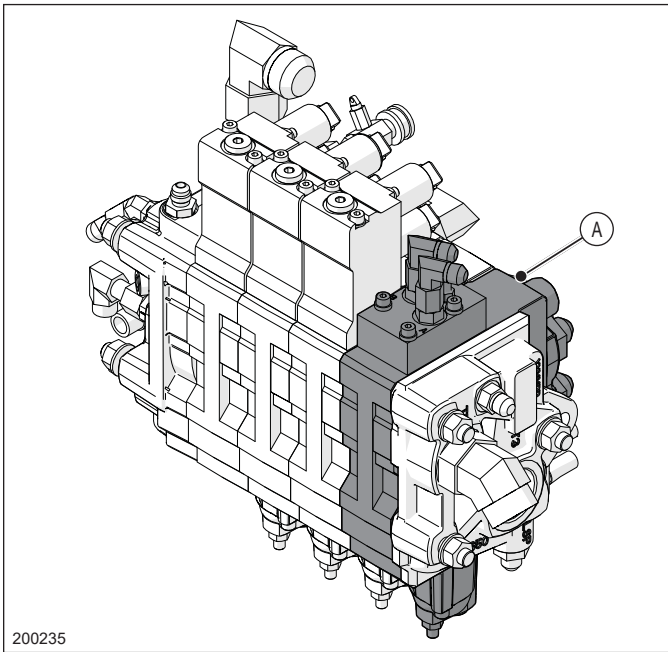

200235

A Grapple Rotate Section

The auxiliary valve is located below the floor plates in the hydraulic valve compartment in front of the main valve.

The Grapple Rotate section of the auxiliary valve is the rear spool section closest to the main valve.

Refer to CONTROL VALVES–AUXILIARY in SECTION 4 for a detailed description of the auxiliary valve.

### AUXILIARY VALVE GRAPPLE FUNCTIONS

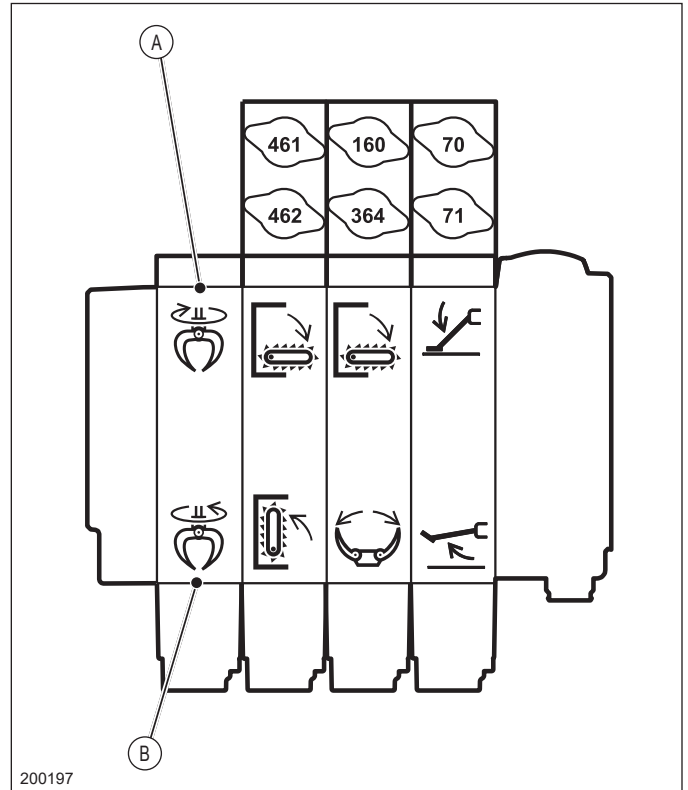

200197

- A Grapple Rotate CW
- B Grapple Rotate CCW

The grapple rotate circuit utilizes the main pump to supply hydraulic oil to the grapple circuit via one spool section in the auxiliary valve.

Refer to SECTION 4 for a more detailed description of the main pump and auxiliary valve.

# Tigercat 250D Loader

## SECTION 22–GRAPPLE SAW

---

Read and understand the entire contents of this manual, and all manuals for any attachments or accessories associated with this machine, prior to operating or servicing this equipment.

### CONTENTS–SECTION 22

ISSUE 1.0, JULY 2020

BOOM CONNECTIONS .....	22.2
CIRCUIT COMPONENTS .....	22.4
CIRCUIT DESCRIPTION .....	22.2
CIRCUIT SCHEMATIC .....	22.5
ELECTRICAL SCHEMATIC .....	22.7
JOYSTICK–LEFT .....	22.3
OPERATING DESCRIPTION .....	22.3
MAIN VALVE .....	22.6
GRAPPLE FUNCTIONS .....	22.6
PRESSURE SETTINGS.....	22.8

## CIRCUIT DESCRIPTION

The delimber/slasher circuit is supplied with hydraulic oil by the main pump to the auxiliary valve, a pilot-operated delimber open/dump valve and pilot operated three-way valve. Two spool sections of the auxiliary valve hydraulically control the delimber and slasher functions.

Joystick switches, the XC21-A2 expansion module, the computer and the XA2-A0 expansion module electrically control the delimber and slasher functions via proportional electro-hydraulic solenoid controls on the auxiliary control valve.

### OPEN DELIMBER ARMS

When the bottom-left button on the left joystick is pressed, an electrical signal is sent to the XC21-A2 expansion module which then sends a CAN signal to the XA2-A0 expansion module. The signal is then sent to energize the delimber open/hold solenoid on the pilot manifold to shift the valve in the delimber open/dump valve. At the same time, a signal is sent to energize the delimber open spool section solenoid on the auxiliary valve to allow internal pilot oil to shift the spool and direct system oil to the delimber open/dump valve. Oil flows through the rotary manifold to the delimber open/dump valve and to the base end of the delimber arm cylinders to open the arms.

When the bottom-left button on the left joystick is released, the delimber open solenoid on the auxiliary valve is de-energized, stopping the flow of oil.

**NOTE:** The delimber open/hold solenoid on the pilot manifold remains energized or 'latched' to hold the delimber arms open.

### CLOSE DELIMBER ARMS

When the bottom-right button on the left joystick is pressed, an electrical signal is sent to the XC21-A2 expansion module which then sends a CAN signal to the XA2-A0 expansion module. The XA2-A0 module then de-energizes the delimber open/hold solenoid on the pilot manifold, allowing oil from the base end of the delimber arms cylinder to return to tank via the delimber open/dump valve, due to oil entering the rod end of the cylinders forced from the delimber accumulator to close the arms.

### CUT WITH DELIMBER TOP SAW

When the bottom-right button on the left joystick is pressed, and the bottom-left button on the right joystick is pressed, an electrical signal is sent to the XC21-A2 expansion module which then sends a CAN signal to the XA2-A0 expansion module. The signal is then sent to energize the saw cut solenoid on the saw cut/retract spool on the auxiliary valve.

Pilot oil flows through the saw cut solenoid pilot valve to shift the spool to allow system oil to flow through the rotary manifold to the pilot operated three-way valve. Because the delimber knives are closed, there is no pressure to shift the three-way valve and the system oil flows to the top saw motor and the rod end of the top saw cylinder to run the saw motor and cut with the saw bar.

### CUT WITH SLASHER

When the bottom-left button on the left joystick is pressed and the bottom-left button on the right joystick is pressed, an electrical signal is sent to the XC21-A2 expansion module which then sends a signal on to the XA2-A0 expansion module. The signal is then sent to open the delimber knives and to energize the saw cut solenoid on the saw cut/retract spool on the auxiliary valve.

The saw cut solenoid allows pilot oil to shift the spool to allow system oil to flow through the rotary manifold to the pilot operated three-way valve. Because the delimber knives are open there is pressure to shift the three-way valve and the system oil flows to slasher saw motor and the rod end of the bar cylinder to run the saw motor and cut with the saw bar.

### RETRACT TOP SAW AND/OR SLASHER

When the bottom-right button on the right joystick is pressed, an electrical signal is sent to the XC21-A2 expansion module which then sends a CAN signal to the XA2-A0 expansion module. The signal is then sent to energize the saw retract solenoid on the saw cut/retract spool on the auxiliary valve.

The saw retract solenoid valve directs pilot oil to shift the spool to allow system oil to flow through the rotary manifold to the base end of the top bar cylinder and the slasher saw cylinder base end to retract the saw bar(s).

CLICK HERE TO **DOWNLOAD** THE COMPLETE MANUAL

- Thank you very much for reading the preview of the manual.
- You can download the complete manual from: [www.heydownloads.com](http://www.heydownloads.com) by clicking the link below



- Please note: If there is no response to CLICKING the link, please download this PDF first and then click on it.

CLICK HERE TO **DOWNLOAD** THE COMPLETE MANUAL