

TEREX AERIALS

SELF-PROPELLED BOOM LIFT MODEL TB120

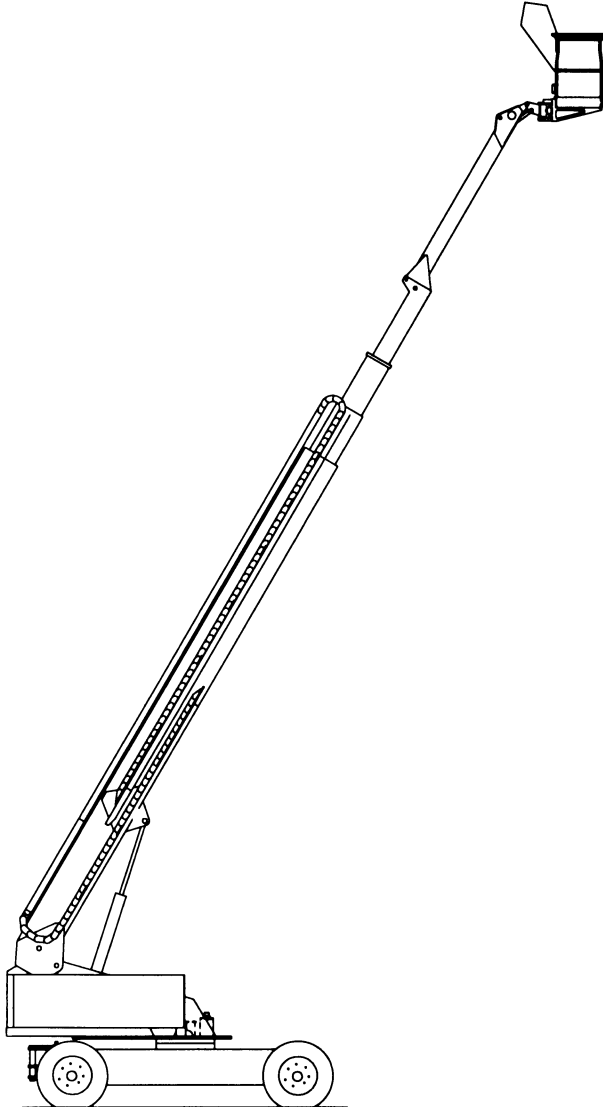

FOR PARTS OR SERVICE
CONTACT:

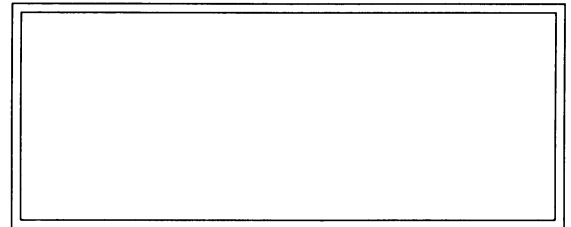

SERVICE AND MAINTENANCE MANUAL

Terex Aerials
10600 W. Brown Deer Road
Milwaukee, WI 53224
U.S.A.

Telephone: (414) 362-9300
Facsimile: (414) 355-0832

Terex Aerials
106 12th Street S. E.
Waverly, IA 50677
U.S.A.

Telephone: (319) 352-3920
Facsimile: (319) 352-5727

Terex Aerials
Courtstown Industrial Park
Little Island, Co.
Cork, Ireland

Telephone: (353) 21-353011
Facsimile: (353) 21-353368

Issued: July '98
P/N 17157

CLICK HERE TO **DOWNLOAD** THE COMPLETE MANUAL

- Thank you very much for reading the preview of the manual.
- You can download the complete manual from: www.heydownloads.com by clicking the link below



- Please note: If there is no response to CLICKING the link, please download this PDF first and then click on it.

CLICK HERE TO **DOWNLOAD** THE COMPLETE MANUAL

MACHINE COMPONENT LOCATOR

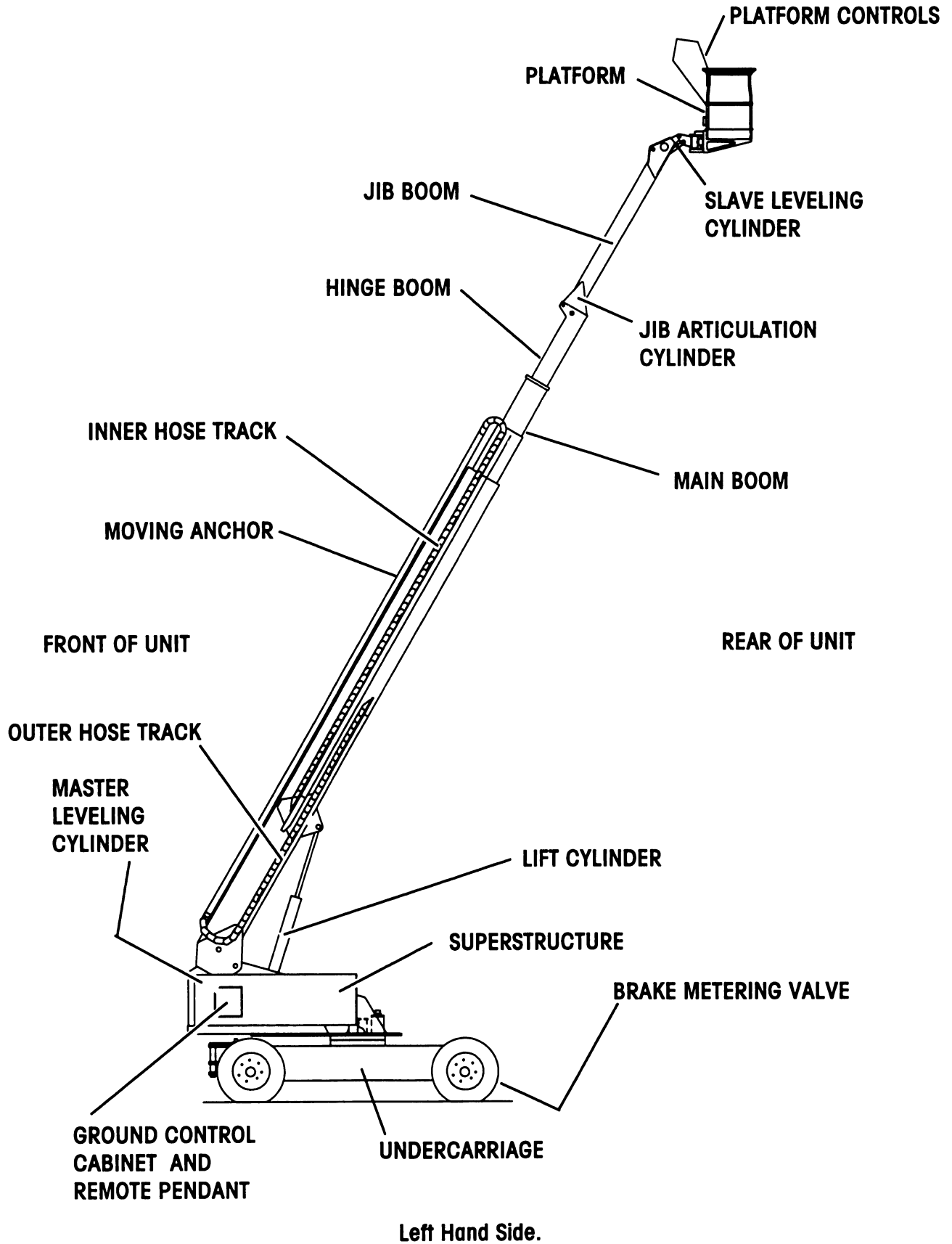

UNLOADING PROCEDURES

WARNING

TO AVOID SERIOUS PERSONAL INJURY OR DEATH, ENSURE THAT THE MACHINE IS IN "LOW" DRIVE SPEED WHILE UNLOADING FROM A TRUCK OR TRAILER.

1. Inspect the outside of the unit for damage (including the underside). Inspect all hoses, boom sections and cables for chafing or shipping damage. Confirm that all wheel lug nuts and swing bearing bolts are tight (refer to specifications).
2. Remove the pin that locks the superstructure to the undercarriage near the swing bearing. Stow the lock pin in the location provided nearby.
3. Unlock and open both side compartments. Inspect all fuel, electrical and hydraulic connections for damage and security.
4. Connect battery cables to batteries if required. Check electrolyte level.
5. Open the fuel tank valve and check fuel level.
6. Check engine oil level, and add as required per engine manufacturer's recommendations.
7. Check fluid level at the sight gauge on the hydraulic tank, and add fluid as required (see Lubrication Chart). Check that shutoff valves on the hydraulic tank are open.
8. Close side compartment covers.
9. Attach the unit to a winch and carefully drive off of trailer.

WARNING

ALWAYS USE A WINCH TO ASSIST LOADING OR UNLOADING THE UNIT FROM A TRUCK OR TRAILER. CONNECT WINCH CABLE TO THE TIE DOWN LUGS ON THE UNDERCARRIAGE. UNASSISTED LOADING OR UNLOADING OF ANY MOBILE PLATFORM IS NOT RECOMMENDED.

READ AND UNDERSTAND ALL SAFETY, CONTROL AND OPERATING INFORMATION FOUND ON THE MACHINE AND IN THIS MANUAL BEFORE OPERATING THE UNIT.

10. Start engine, using the ground controls.

NOTE: Refer to Start-up Procedures and Operator Controls Descriptions in this section.

After a brief warm-up period, select the "HI" engine speed. On the remote control pendant, press and hold the "PUMP" toggle switch to the "MAIN" position, but do not operate any drive or boom function. This is called "deadheading", and will lead to maximum system pressure registering on the gauge at the ground control valve assembly. Refer to the "Machine Specifications" section of this manual for the "Maximum Hydraulic Pressure" for this unit.

Select the "LOW" engine speed and allow the engine to slow to idle speed.

11. Remove tie downs from the platform and base of the jib boom.
12. Remove the two straps that wrap over the top of the undercarriage. Remove four tie down chains. Remove wheel chocks, if used.

HYDRAULIC FLUID RESERVOIR

The hydraulic fluid reservoir consists of the tank, a sight gauge, a filler cap with filter, a strainer, a vent, a sump with drain plug, one valve for suction line, five valves for return lines and a valve for the emergency pumps suction line.

HYDRAULIC RESERVOIR MAINTENANCE

Check tank for signs of leakage. Inspect tank securing bolts for tightness. Clean cap filter by flushing with clean water and dry thoroughly.

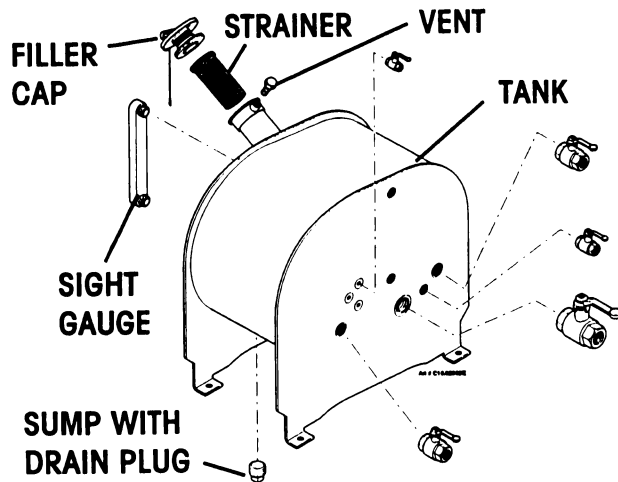

Hydraulic Fluid Reservoir.

HIGH PRESSURE FILTER

The hydraulic high pressure filter is a non-bypassing filter. This filter allows maximum fluid flow as long as the filter element is free of contaminants. When the filter is clogged, it shuts down the hydraulic flow but will not crush the filter element due to a differential pressure limiting valve. The build-up of pressure across the filter will affect system performance and act as an indication of a clogged filter.

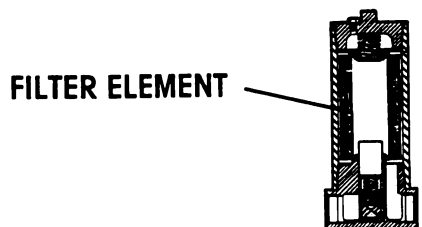

High Pressure Filter.

BOOM LIFT SYSTEM

The boom lift system consists of a hydraulic valve segment on the ground valve bank, a flow control valve, a lift cylinder with a counterbalance (holding) valve, a lift toggle switch on the pendant and a control lever on the platform console.

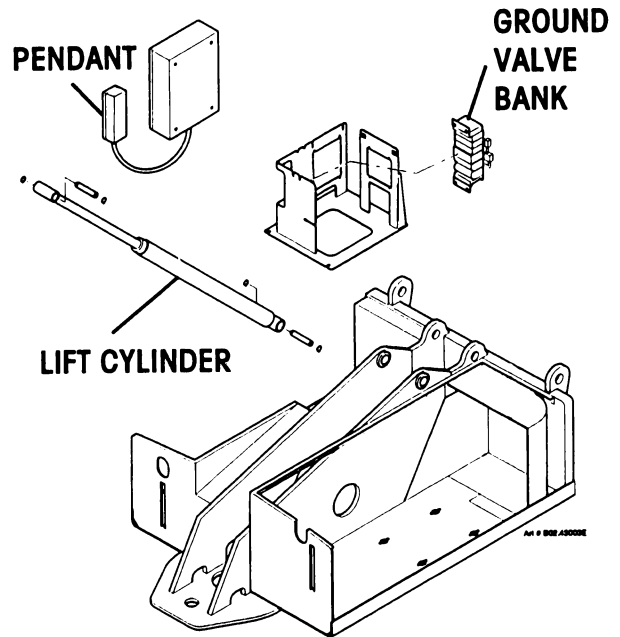

Boom Lift System Components.

BOOM LIFT VALVE SEGMENT

When the boom control lever on the platform control or the boom control toggle switch on the control pendant is activated, an electrical signal is transmitted to the valve cartridge in the boom lift (hoist) valve segment. This allows hydraulic fluid at the correct pressure to be sent to the proper end of the lift cylinder to raise or lower the boom.

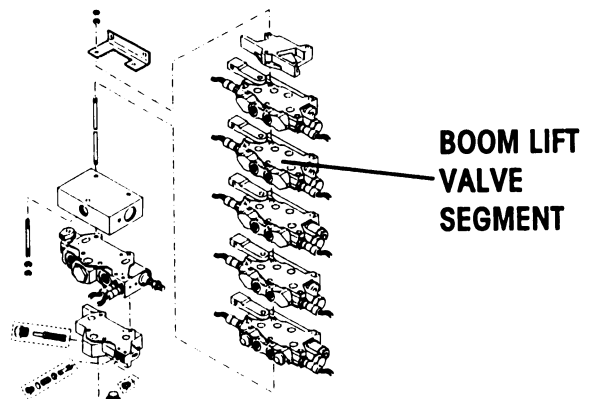

Ground Valve Bank Assembly.

The axle extend system consists of the selector valve assembly, the steer valve segment, hydraulic swivel, two axle extend cylinders, axle stops, steer toggle switch on the pendant and the steer control toggle on the end of the drive lever at the platform control.

The axle extend system utilizes the same hydraulic circuit as the steer system until the selector valve is

positioned to extend the axles; then the hydraulic fluid is diverted to the axle extend cylinders.

AXLE EXTEND CYLINDERS

The two cylinders are double acting and are directly connected to telescoping axles. These cylinders power all axle extend/ retract movement.

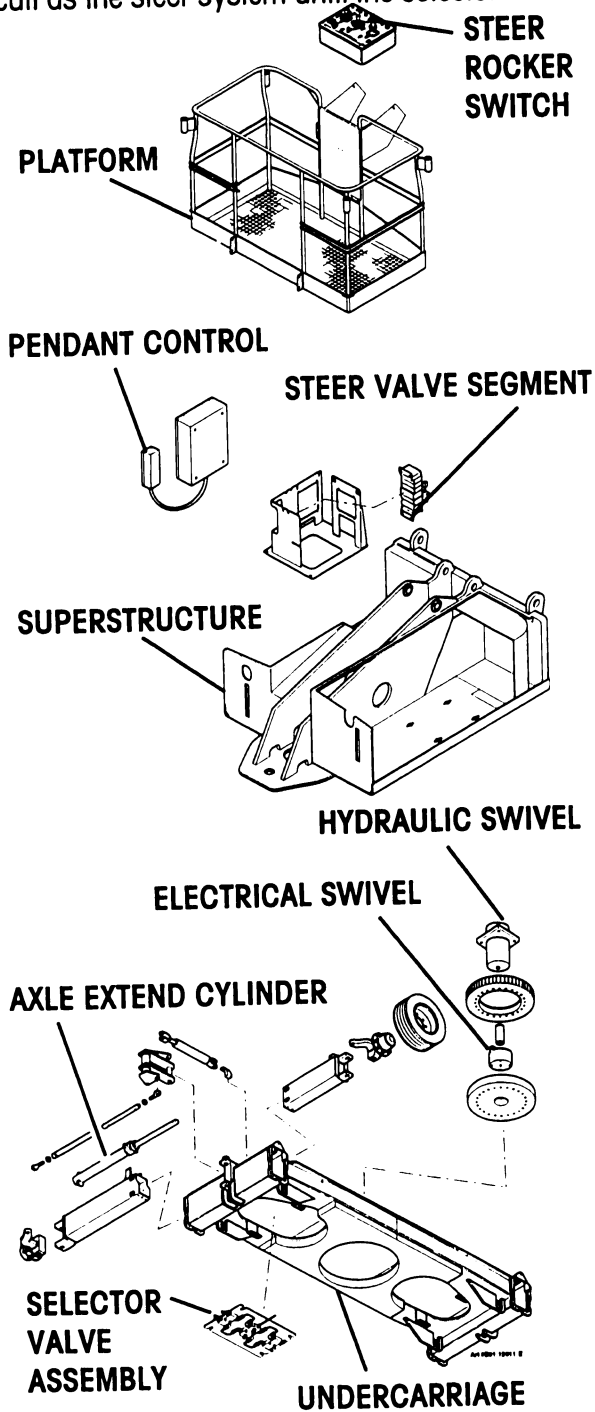

Steer System Components.

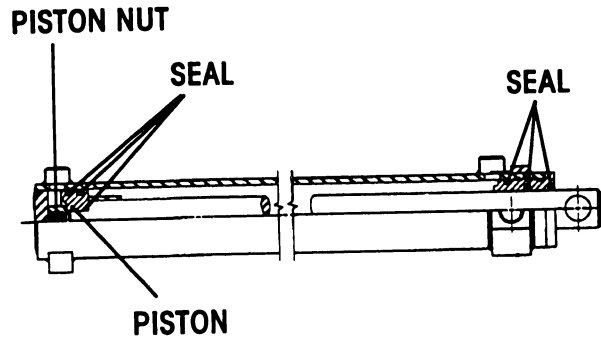

Axle Extend Cylinder.

SELECTOR VALVE ASSEMBLY

The selector valve assembly consists of three valves: one double parallel selector valve and two pilot operated crossover check valves. This valve assembly determines whether fluid flows to the steer cylinder or the axle extend cylinders.

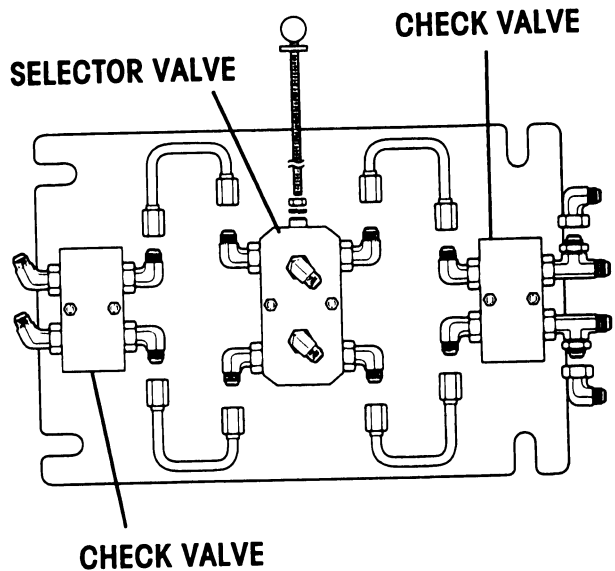

Selector Valve Assembly.

HYDRAULIC SYSTEM COMPONENTS

Table of Contents, Section 4

Electrical System	4-3
Battery	4-3
Battery Maintenance (In Storage)	4-3
Battery Maintenance (In Use)	4-3
Battery Preventive Maintenance	4-4
Battery Replacement	4-4
Movement Alarm	4-4
Tilt Alarm	4-4
Tilt Alarm Test	4-4
Tilt Alarm Adjustment	4-5
Relays	4-5
Circuit Breakers	4-5
Limit Switches	4-5
Emergency Pumps	4-5
Platform Envelope Control System	4-6
Emergency Stop Buttons	4-6
Emergency Stop Cable Adjustment	4-6
Pendant Switch Removal	4-6
Ground Control Cabinet Switch Removal	4-6
Platform Console Switch Removal	4-6
Drive Controller	4-6
Creep Speed Adjustments	4-8
Boom Telescope Adjustment	4-8
Superstructure Swing Adjustment	4-8

CLICK HERE TO **DOWNLOAD** THE COMPLETE MANUAL

- Thank you very much for reading the preview of the manual.
- You can download the complete manual from: www.heydownloads.com by clicking the link below



- Please note: If there is no response to CLICKING the link, please download this PDF first and then click on it.

CLICK HERE TO **DOWNLOAD** THE COMPLETE MANUAL

Table of Contents, Section 5

Mechanical Components	5-3
Tires	5-3
Changing Tires	5-3
Wheels and Lug Nuts	5-3
Drive Hub Assembly	5-4
Steer Cylinder Pins	5-5
Steer Cylinder	5-5
Steer Arm Pin	5-6
Tie Rod Assembly	5-6
Superstructure	5-7
Hoses and Cables	5-8
Miscellaneous Equipment	5-8
Boom	5-8
Boom Pivot Pin and Bushing Replacement	5-8
Boom Lift Cylinder	5-9
Lift Cylinder Pivot Pin Replacement	5-9
Lift Cylinder Seal Replacement (On Machine)	5-9
Check Holding Valves	5-9
Boom Disassembly	5-10
Boom Assembly	5-14
Boom Telescope (Extend) Cylinder	5-17
Telescope (Extend) Boom Cylinder Pin Replacement	5-18
Telescope (extend) Cylinder Removal	5-18
Telescope Cylinder Seal Replacement	5-18
Telescope Cylinder Installation	5-18
Checking Holding Valves	5-18
Boom Wire Rope Adjustment	5-18
Boom Wire Rope Replacement	5-21
Wear Pads	5-21
Platform Level Cylinders	5-21
Platform Level Cylinder Pin Replacement	5-22
Level Cylinder Seal Replacement	5-22
Platform Leveling Procedure	5-22
Axle Extend Assembly	5-24
Axle Extend Cylinder	5-24
Axle Extend Cylinder Replacement	5-24
Axle Extend Cylinder Seal Replacement	5-26
Mechanical Axle Stop	5-26
Axle Tube Assembly Replacement	5-26

10. Remove the Catrac and trough assembly. The assembly is secured to the booms with three brackets and the moving anchor mounting. Lay the assembly with hoses to the side.
11. Disconnect boom length sensor reels at the cable end attached to eye bolts on the boom.
12. Remove the four cables from the back of base boom. Slide them inside base boom.
13. Remove wear pads from rear of base boom. For bottom wear pads and retract cable support block, the mid boom must be slid further and lifted up.
14. Slide second stage all the way out of base boom and carefully tie up cables, ensuring that cables are not crossed.
15. While supporting the extend cylinder, remove the two telescope cylinder trunnion rings. They are secured in place by six bolts each. Also, remove retract rope guides from second stage.

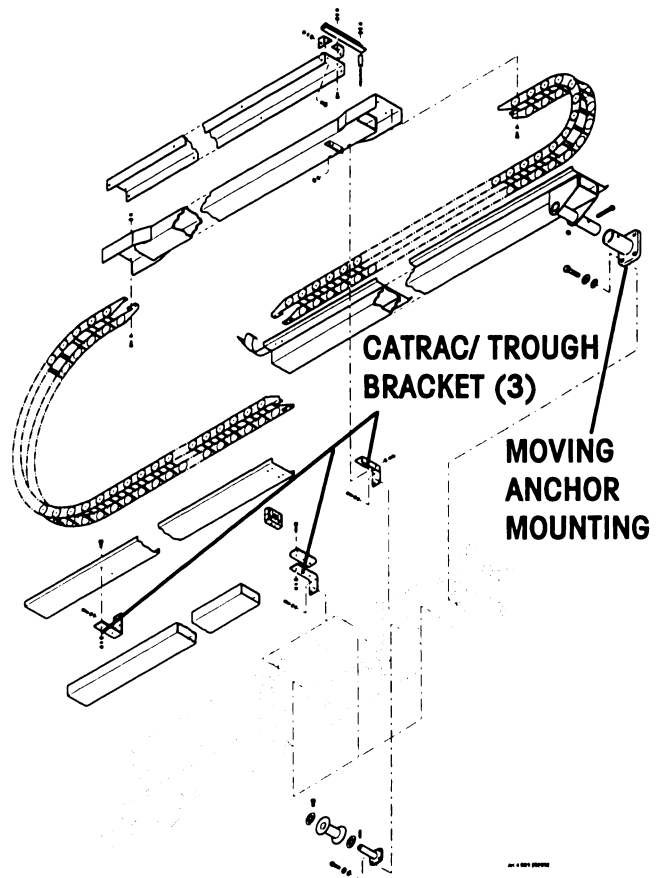

Catrac and Trough Assembly.

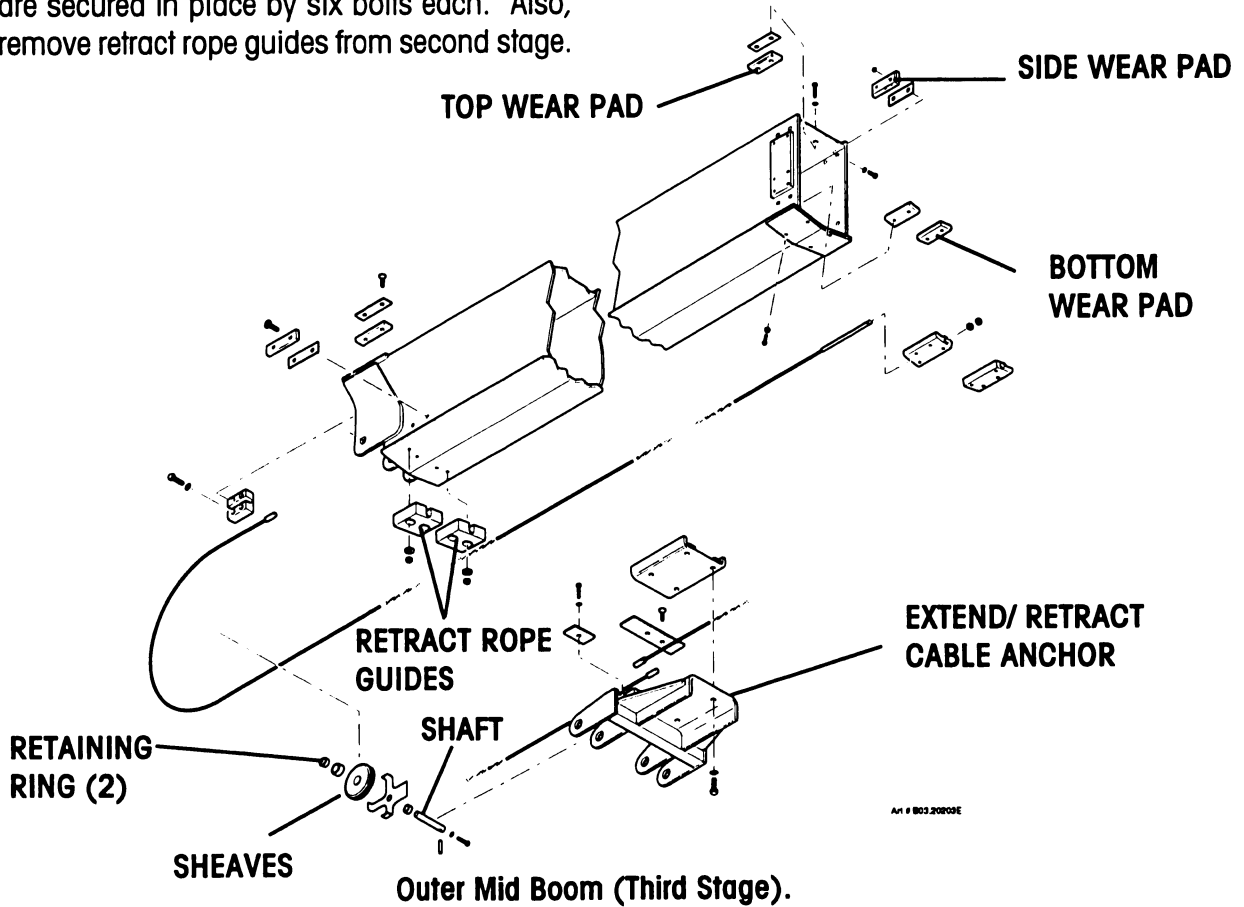

Outer Mid Boom (Third Stage).

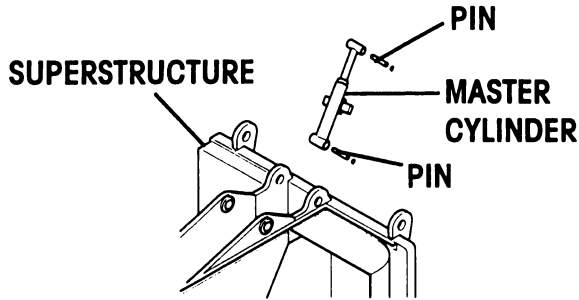

Master Cylinder Pin Replacement.

fluid leakage, damage and security. The seals should be replaced whenever the cylinder is serviced.

PLATFORM LEVEL CYLINDER PIN REPLACEMENT

SUPPORT THE PLATFORM to remove the load on both master and slave leveling cylinders. Remove the retaining ring, the pin locking bolts and nuts, and remove the pin.

Install new pin, locking bolts and nuts (lubricate bolts before installation) and retaining ring. Apply grease to pin.

LEVEL CYLINDER SEAL REPLACEMENT

Lower the main boom. SUPPORT THE PLATFORM to remove the load on both master and slave leveling cylinders. Remove the lock collar and pin. Slave

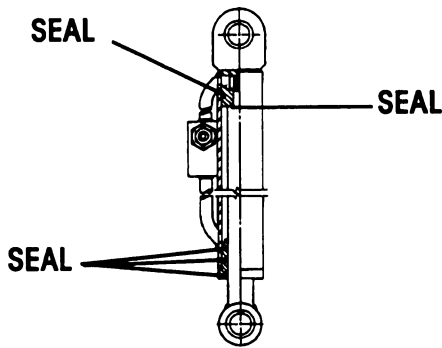

Slave Level Cylinder.

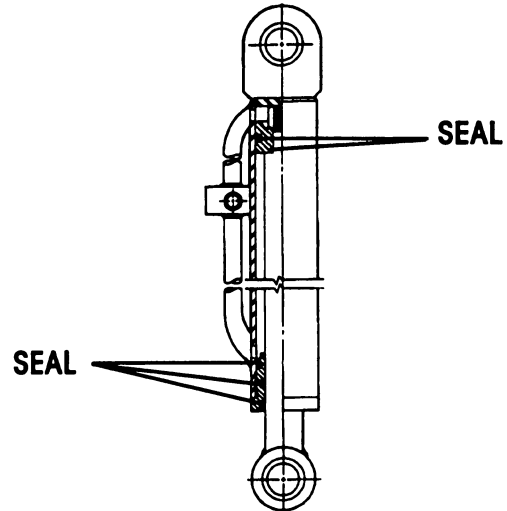

Master Level Cylinder.

cylinder seals can be replaced on the machine. Master cylinder must be removed for seal replacement.

Clean the end of the cylinder. Unscrew the end cap and pull the cap and rod straight out of the cylinder barrel. TAKE CARE NOT TO DAMAGE THE ROD SURFACE, AND GUARD AGAINST DIRT ENTERING THE SYSTEM. Remove the split pin and nut from the end of the rod. Slip off the collar. Examine the rod and seals for signs of damage or wear.

Remove the old seals and install a new seal kit.

PLATFORM LEVELING PROCEDURE

After a platform level cylinder has been repaired or replaced, or if the platform does not remain level with the raising and lowering of the boom, the platform leveling circuit may need to be bled.

With the platform near ground, operate the platform level control to move the platform fully backward and forward. Perform procedure five (5) times in order to expel any air from the system.



CARE MUST BE TAKEN WHEN OPERATING LEVEL CONTROL. AIR IN CYLINDERS CAN CAUSE UNCONTROLLED PLATFORM MOTION.

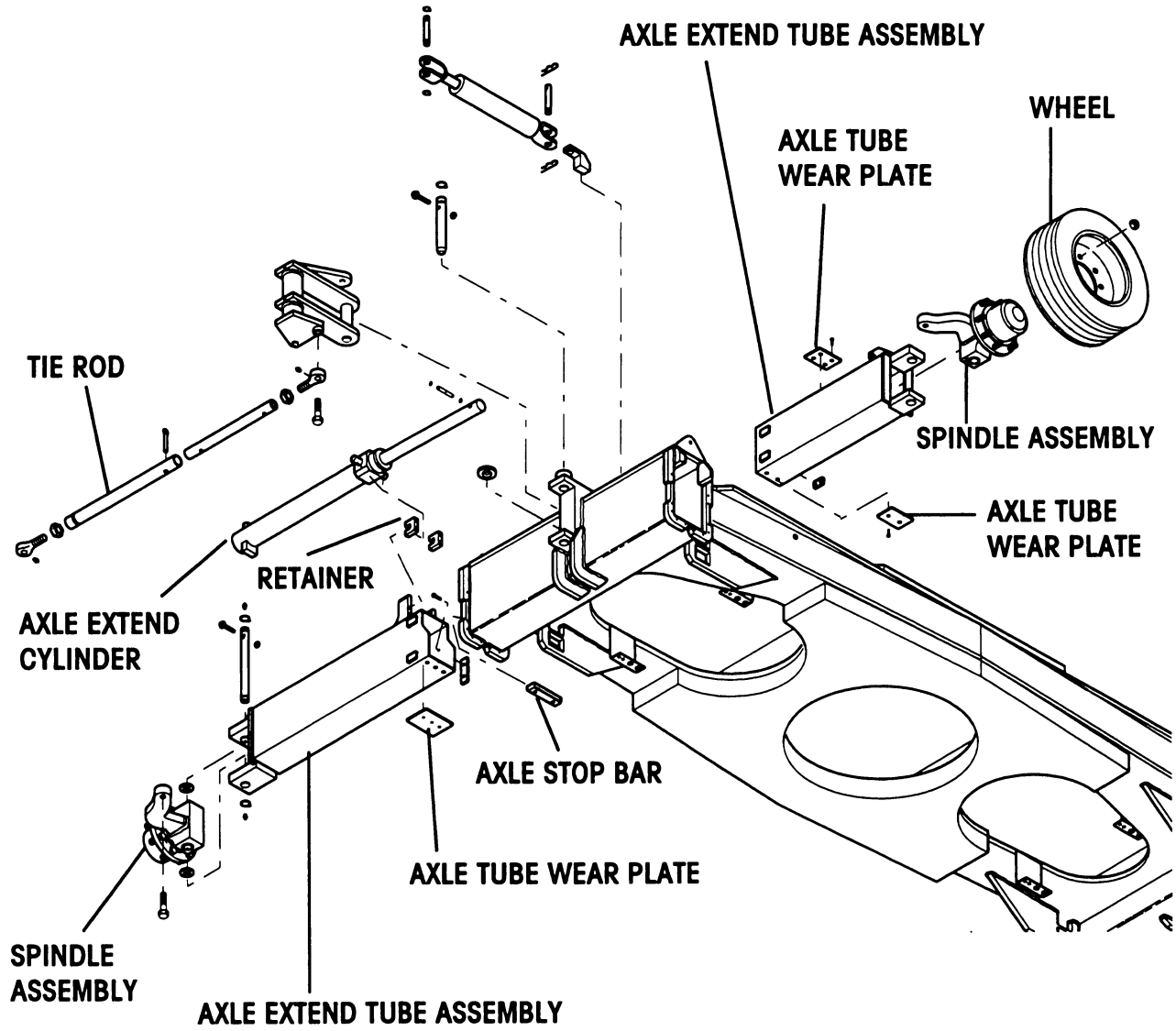

Axle Extend Tubes Assembly Installation.

SHIFT OPERATIONAL CHECKLIST (CONTINUED)

INITIAL	DESCRIPTION
_____	21. Check emergency pumps for operation and that pressure is as stated in the specifications.
_____	22. Check platform controls and graphic display for proper operation.
_____	23. With the platform raised, check for the smooth operation of creep speed drive.
_____	24. Follow engine daily service requirements. Refer to the Engine Maintenance Manual supplied with your RP 120.
_____	25. If the black line on the side of the tip boom is out from the outer mid boom more than 6 inches, the system needs calibration.

NOTE: To perform this check, the axles must be extended, the jib boom must be fully lowered (90° below main boom), the main boom must be horizontal and the platform must be extended out until it stops.

ADDITIONAL MAINTENANCE REQUIREMENTS FOR HARSH ENVIRONMENTS

NOTE: Do not lubricate wear pads or boom cables in dusty or sandblast environments. There are boots and guards available to extend unit life in these applications. Consult Simon Aerials Service Department.

INITIAL	DESCRIPTION
_____	• Inspect cylinder boots, valve spool boots, etc., for cuts or other damage after every eight (8) hours of service. Repair or replace if necessary.
_____	• Check hydraulic system for leakage after every eight (8) hours of operation.
_____	• Follow engine severe usage service requirements. Refer to the Engine Maintenance Manual supplied with your RP 120.

TROUBLESHOOTING CHART

Problem	Probable Cause	Solution
<ul style="list-style-type: none"> Excessive heat will cause excessive wear on seals and metal parts due to lowered viscosity. Symptoms to watch for are: pump case turns brown, hydraulic fluid darkens and premature pump failure. 	<ul style="list-style-type: none"> Excessive water in the hydraulic fluid. Improper oil viscosity. Improper lubrication and hydraulic fluid. Pump cam bearing failure. Open stroke flow valve. Foot pedal blocked closed. 	<ul style="list-style-type: none"> Drain and flush hydraulic system. Replace hydraulic fluid with the correct fluid. Drain and flush hydraulic system. Rebuild pump as required. Close pump stroke valve. Unblock foot pedal.
<ul style="list-style-type: none"> Water in hydraulic fluid. Symptoms to watch for are: pitting and etching of pump pistons with pump piston cam wear causing heat build up and premature pump failure. 	<ul style="list-style-type: none"> Damp climate. Hydraulic fitting or port open to contaminants. Reservoir pressurization inoperative. 	<ul style="list-style-type: none"> Drain and flush hydraulic system. Drain and flush hydraulic system. Replace worn pump components. Check pressure.
<ul style="list-style-type: none"> Varnish, the dark brownish residue left from oxidation of hydraulic fluids. Symptoms to watch for are: residue will cause pistons and spools to stick and will hang up moving parts with close tolerances. 	<ul style="list-style-type: none"> Incompatible fluids or poor quality fluids. Excessive heating of the fluids. 	<ul style="list-style-type: none"> Drain and flush hydraulic system, then fill with recommended hydraulic fluid and lubricant. Drain and flush hydraulic system, then fill with recommended hydraulic fluid.
<ul style="list-style-type: none"> Poor lubrication, parts break through lubricant causing metal to metal contact. Symptoms to watch for are: heads of pump pistons worn to shape of cam and excessive heat build up. 	<ul style="list-style-type: none"> Hydraulic fluid viscosity low. Improper or poor grade hydraulic fluid or lubricant without proper anti wear additives. 	<ul style="list-style-type: none"> Drain and flush hydraulic system, then fill with recommended hydraulic fluid. Drain and flush hydraulic system, then fill with recommended hydraulic fluid and lubricant.

TROUBLESHOOTING CHART

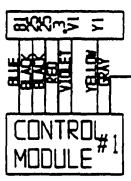
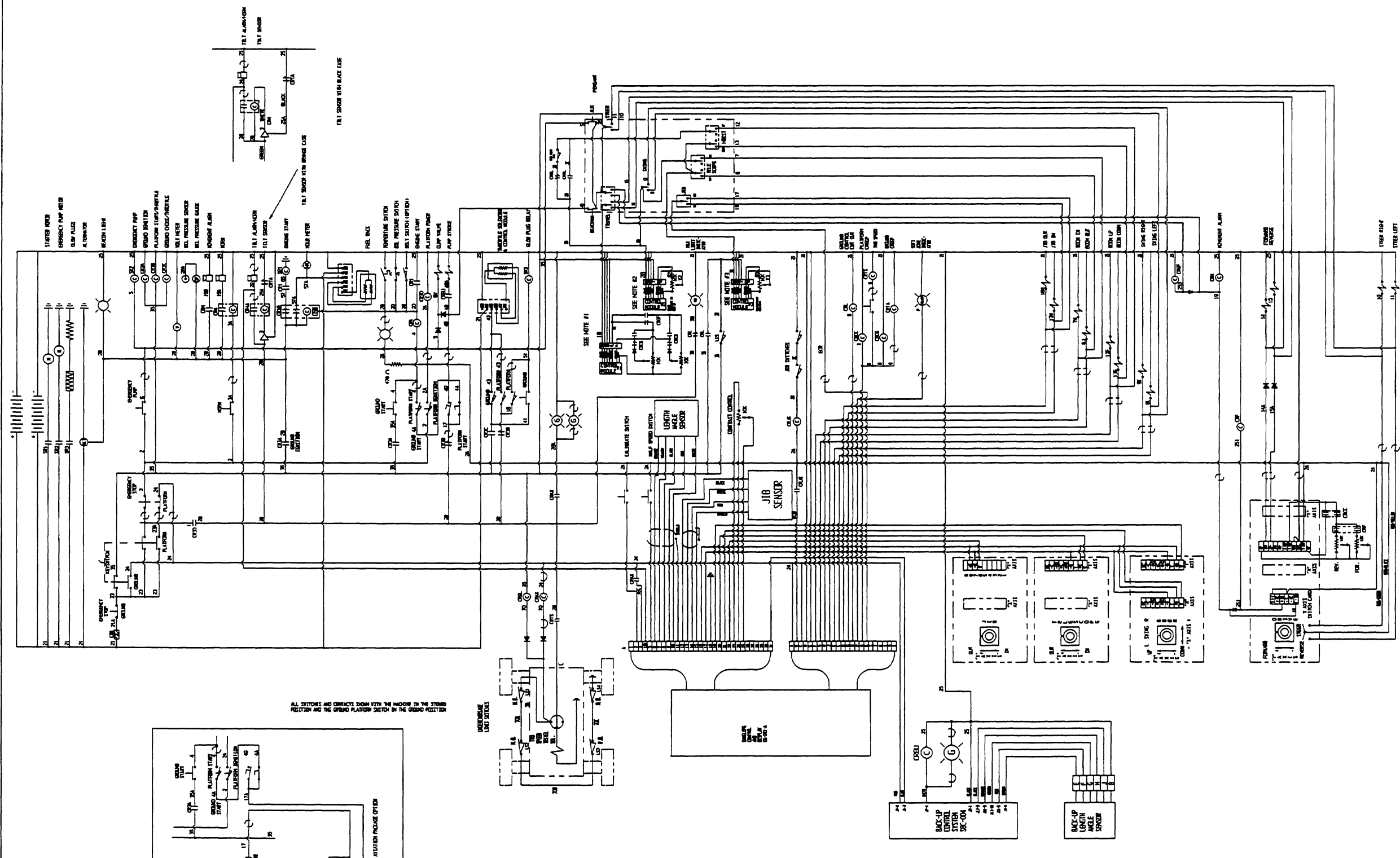

NOTE #1

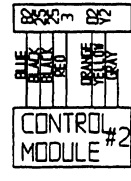

NOTE #2

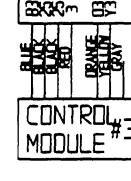

NOTE #3

ALL SWITCHES AND CONTACTS DOWN WITH THE INCHES IN THE STAIR POSITION AND THE GROUND PLATFORM SWITCH IN THE GROUND POSITION

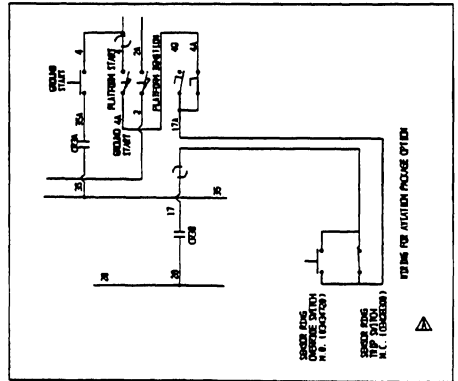

STOPPING SYSTEM
EMERGENCY STOP
H.P. (GROUND)
EMERGENCY STOP
H.P. (GROUND)

USE AS A GUIDE
UNDO SWITCHES

REV. DATE		DESCRIPTION		ELECTRICAL SCHEMATIC	
1	10-10-04	REVISED			
2	12-2-04	REVISED	ADD WIRING TO NEW WIREWAY		
3	1/25/04	REVISED	REVISED		
DO NOT SCALE PRINT				CASKEY DRAWING DO NOT REVISE MANUALLY	
DRAWN BY		CHECKED BY		DATE	
R.R.		R.R.		1/25/04	
PROJECT NO.				0-2327790	

SIMON AERIALS INC.

Index (Continued)

- | | | | |
|---|-------------|--|-------------|
| Hydraulic Lines | 2-9 | Platform | |
| Check | 2-9 | Control Handle | 3-5 |
| Hydraulic Pump | 2-7 | Platform Component Locator | xvii |
| Adjustment | 2-7 | Platform Console Switch | 4-6 |
| Hydraulic Swivel | 2-10, 2-21, | Removal | 4-6 |
| | 2-23 | Platform Console Switch Removal | 4-6 |
| Hydraulic System | 6-3, 6-4 | Platform Level Cylinder Pin | |
| I | | Replacement | 5-20 |
| Integral Brake Assembly | 2-15 | Platform Level Cylinders | 5-19 |
| Introduction | vii | Master | 5-19 |
| J | | Pin Replacement | 5-20 |
| Joystick | 3-5. | Seal Replacement | 5-20 |
| <i>See also</i> Control Handle | | Slave | 5-19 |
| L | | Platform Level System | 2-18 |
| Level Control Valve | 2-19 | Double Pilot Operated Check Valve ... | 2-19 |
| Level Cylinder Seal Replacement | 5-20 | Level Control Valve | 2-19 |
| Lift Cylinder Pivot Pin Replacement | 5-9 | Master Level Cylinder | 2-19 |
| Lift Cylinder Seal Replacement | 5-9 | Relief Valves | 2-20 |
| Limit Switches | 4-5 | Slave Level Cylinder | 2-19 |
| Lubrication Chart | xviii, xix | Platform Leveling Procedure | 5-20 |
| M | | Platform Mounting | 6-5 |
| Machine Specifications | ix | Platform Rails and Safety Gate | 6-3 |
| Maintenance Schedule | 6-3 | Platform Rotate System | |
| Master Level Cylinder | 2-19 | Double Pilot Operated Check Valve ... | 2-17 |
| Mechanical Components | 5-3 | Platform Rotator Manifold | 2-18 |
| Mechanical Axle Stop | 5-24 | Rotary Actuator | 2-17 |
| Miscellaneous Equipment | 5-8 | Maintenance | 2-18 |
| Monthly Operational Checklist | 6-11 | Rotate Control Valve | 2-17 |
| Monthly Service | 6-4 | Platform Rotator Manifold | 2-18 |
| Motion Control Valve | 3-4 | Pressure Relief Valve | 2-14 |
| Motion Control Valve Assembly | 3-4 | R | |
| Flow Control Valve | 3-4 | Receipt Inspection Adjustment Report ... | 2-14 |
| Motion Control Valve | 3-4 | Relays | 4-5 |
| Movement Alarm | 4-4 | Relief Valves | 2-20 |
| O | | Report the incident to your supervisor ... | 2-18 |
| Operator Incapacitated | 2-19, 2-20 | Reservoir | 2-12 |
| P | | Maintenance | 2-12 |
| Pendant Control | | Rotary Actuator | 2-17 |
| Toggle Switch | 3-5 | Maintenance | 2-18 |
| Pendant Switch | | Rotary Actuator Maintenance | 2-18 |
| Removal | 4-6 | Routine Servicing | 6-3 |
| Pendant Switch Removal | 4-6 | S | |
| Pivot Pins and Bearings | 6-5 | Selector Valve | 2-20, 2-23, |
| Pivot Pins and Grease Fittings | 6-4 | | 3-4 |
| | | Selector Valve Assembly | 2-20, 2-23 |
| | | Check Valve | 2-21, 2-23 |
| | | Selector Valve | 2-20, 2-23 |
| | | Semi-Annual Operational Checklist | 6-13 |
| | | Shift Operational Checklist | 6-6 |
| | | Slave Level Cylinder | 2-19 |

INDICATORS

Five front-panel LEDs are provided to alert the operator to different system conditions. The POWER LED indicates that the system has power and is running. The OK LED indicates that the computer is functioning properly and all internal tests have passed. The FAIL LED indicates that a problem has been detected and the unit may not function properly. The WARNING LED indicates that the boom tip or platform side reach is within four feet of the side reach limit. The STOP LED indicates that maximum platform side reach has been achieved.

moving from the first calibration position to the second, the operator fully boom up before extending. This will allow operation within safe limits. Failure to follow this sequence may cause the machine to tip over.

CAUTION: It is important for proper calibration, that the chassis be level, Failure to comply will result in errors in side reach calculations and may result in unsafe operating positions.

DISPLAY CONTRAST

The readability of the liquid crystal display depends on the viewing angle. Adjust the contrast control for best results.

The calibration procedure should be run when the system is first installed or when the length/angle or jib sensors are replaced or adjusted. The factory-programmed calibration values are for test purposes only. One sequence calibrates both the HE001A (primary) and the HD009A (backup) controllers.

CALIBRATION

WARNING: Calibration must only be performed by qualified personnel. Failure to follow proper sequences or use of invalid calibration points can result in unsafe platform positions.

The machine should be at rest on a level surface with the axles extended to perform this procedure. Turning the CALIBRATION key starts the process and signals the controller that each step of the calibration procedure has been completed. Holding the key in the on position for 3-5 seconds assures proper reading of the switch.

WARNING: While in calibration mode, the envelope control and the backup system are overridden. It is imperative that while

The LCD display prompts the operator to position the machine in two ways. The first is with the boom fully retracted, with the jib at -90 degrees and with the

CLICK HERE TO **DOWNLOAD** THE COMPLETE MANUAL

- Thank you very much for reading the preview of the manual.
- You can download the complete manual from: www.heydownloads.com by clicking the link below



- Please note: If there is no response to CLICKING the link, please download this PDF first and then click on it.

CLICK HERE TO **DOWNLOAD** THE COMPLETE MANUAL