

FOREWORD

This manual contains an introductory description on the SUZUKI LT-A400/F, LT-F400/F and procedures for its inspection/service and overhaul of its main components.

Other information considered as generally known is not included.

Read the GENERAL INFORMATION section to familiarize yourself with the vehicle and its maintenance. Use this section as well as other sections to use as a guide for proper inspection and service.

This manual will help you know the vehicle better so that you can assure your customers of fast and reliable service.

- * This manual has been prepared on the basis of the latest specifications at the time of publication. If modifications have been made since then, differences may exist between the content of this manual and the actual vehicle.*
- * Illustrations in this manual are used to show the basic principles of operation and work procedures. They may not represent the actual vehicle exactly in detail.*
- * This manual is written for persons who have enough knowledge, skills and tools, including special tools, for servicing SUZUKI vehicles. If you do not have the proper knowledge and tools, ask your authorized SUZUKI motorcycle dealer to help you.*

▲ WARNING

Inexperienced mechanics or mechanics without the proper tools and equipment may not be able to properly perform the services described in this manual.

Improper repair may result in injury to the mechanic and may render the vehicle unsafe for the rider and passenger.

SUZUKI MOTOR CORPORATION

CLICK HERE TO **DOWNLOAD** THE COMPLETE MANUAL

- Thank you very much for reading the preview of the manual.
- You can download the complete manual from: www.heydownloads.com by clicking the link below



- Please note: If there is no response to CLICKING the link, please download this PDF first and then click on it.

CLICK HERE TO **DOWNLOAD** THE COMPLETE MANUAL

Battery

- Battery connection in reverse polarity is strictly prohibited. Such a wrong connection will damage the components of the FI systems instantly when reverse power is applied.

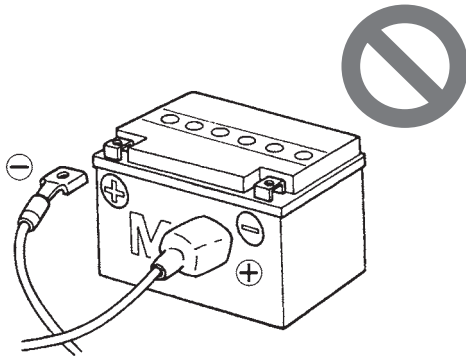

I718H1000004-01

- Removing any battery terminal of a running engine is strictly prohibited. The moment such removal is made, damaging counter electromotive force will be applied to the CDI unit which may result in serious damage.

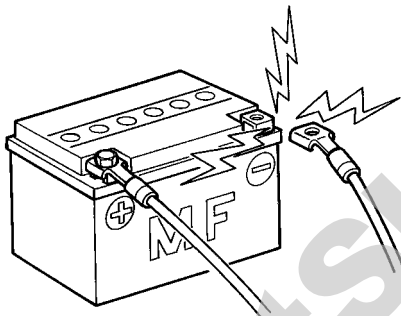

I310G1000011-01

- Before measuring voltage at each terminal, check to make sure that battery voltage is 11 V or higher. Terminal voltage check with a low battery voltage will lead to erroneous diagnosis.

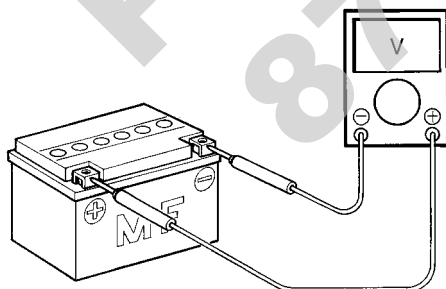

I310G1000012-02

- Never connect any tester (voltmeter, ohmmeter, or whatever) to the electronic unit when its coupler is disconnected. Otherwise, damage to electronic unit may result.
- Never connect an ohmmeter to the CDI unit with its coupler connected. If attempted, damage to CDI unit may result.
- Be sure to use a specified voltmeter/ohmmeter. Otherwise, accurate measurements may not be obtained and personal injury may result.

Electrical Circuit Inspection Procedure

While there are various methods for electrical circuit inspection, described here is a general method to check for open and short circuit using an ohmmeter and a voltmeter.

Open circuit check

Possible causes for the open circuit are as follows. As the cause can exist in the connector/coupler or terminal, they need to be checked carefully.

- Loose connection of connector/coupler
- Poor contact of terminal (due to dirt, corrosion or rust, poor contact tension, entry of foreign object etc.)
- Wire harness being open.
- Poor terminal-to-wire connection.

When checking system circuits including an electronic control unit such as CDI unit, etc., it is important to perform careful check, starting with items which are easier to check.

- 1) Disconnect the negative (–) cable from the battery.
- 2) Check each connector/coupler at both ends of the circuit being checked for loose connection. Also check for condition of the coupler lock if equipped.

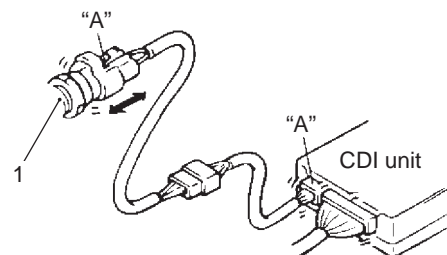

I827H1000001-01

1. Sensor

"A": Check for loose connection

Component Location

Electrical Components Location

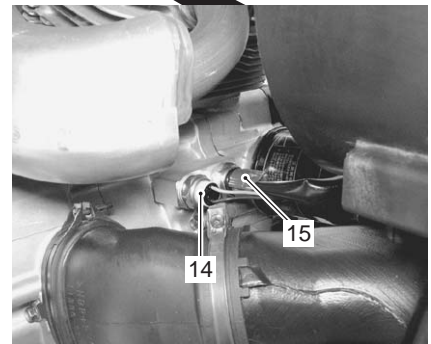
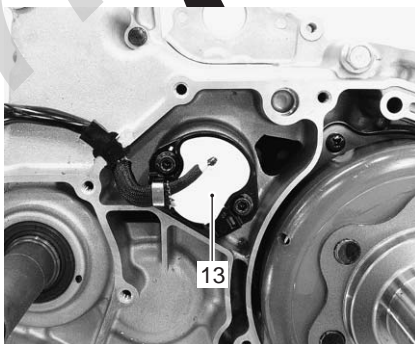
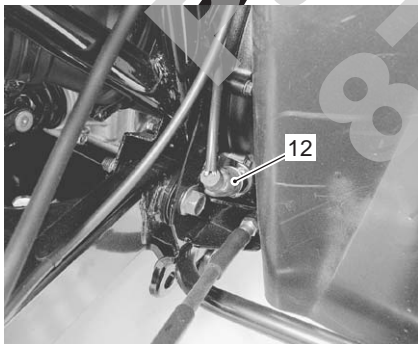
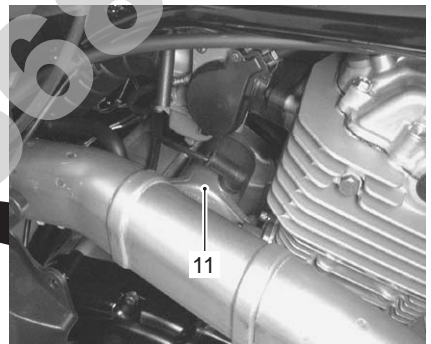
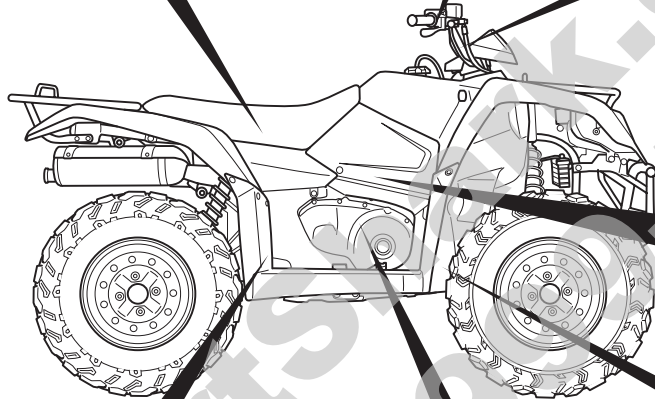
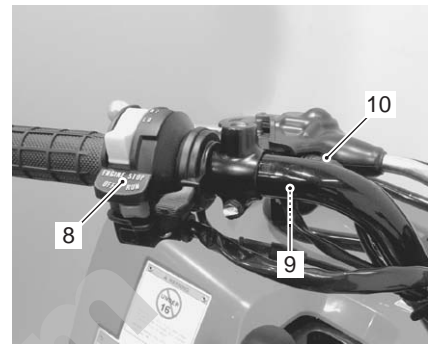
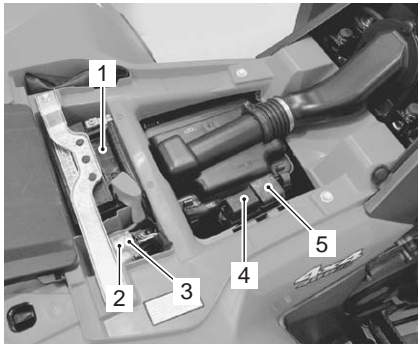

LT-A400/F

B827H20103001

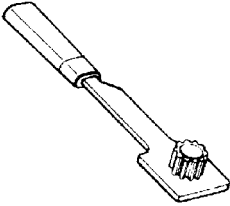
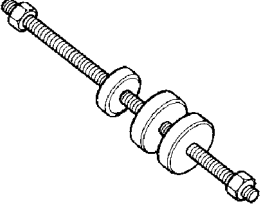
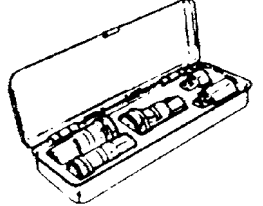
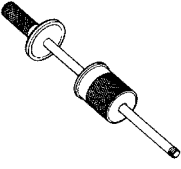
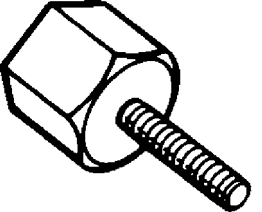
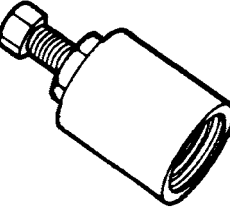
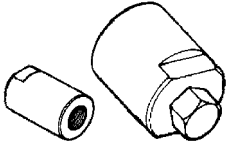
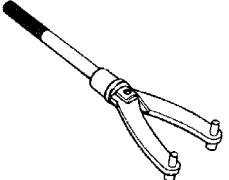
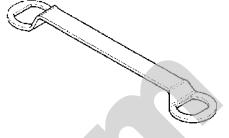
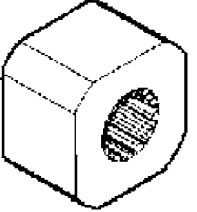
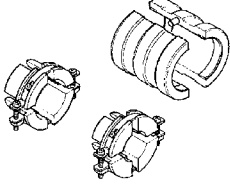

I827H1010007-01

1. Battery	6. Ignition switch	11. Starter motor
2. Main fuse	7. Output terminal	12. Brake light switch
3. Starter relay	8. Handlebar switch (LH)	13. Neutral switch
4. Neutral relay	9. Parking brake switch	14. Cooling fan thermo-switch
5. Fuse box	10. Brake light switch	15. Engine oil temperature switch

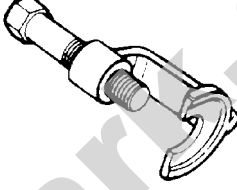
 <p>09924-64510 Final driving gear coupling holder</p>	 <p>09924-84521 Bearing installer set</p>	 <p>09930-10121 Spark plug wrench set</p>	 <p>09930-30104 Rotor remover slide shaft</p>	 <p>09930-30141 Attachment A</p>
 <p>09930-30721 Rotor remover</p>	 <p>09930-31921 Rotor remover</p>	 <p>09930-40113 Rotor holder</p>	 <p>09930-44541 Rotor holder</p>	 <p>09930-73190 Output shaft holder</p>
 <p>09940-52861 Front fork oil seal installer</p>	 <p>09941-64511 Bearing remover</p>	 <p>09942-72410 Tie rod end remover</p>		

PartShark.com
877-999-5686

Front Differential Gear Oil Replacement (LT-A400F, LT-F400F)

B827H20206010

Replace front differential gear oil Every 2 years

Replace the oil filter differential gear oil in the following procedures:

- 1) Place the vehicle on level ground.
- 2) Remove the front under cover. Refer to "Exterior Parts Removal and Installation in Section 9D (Page 9D-3)".
- 3) Remove the oil filter plug (1) and oil level plug (2).

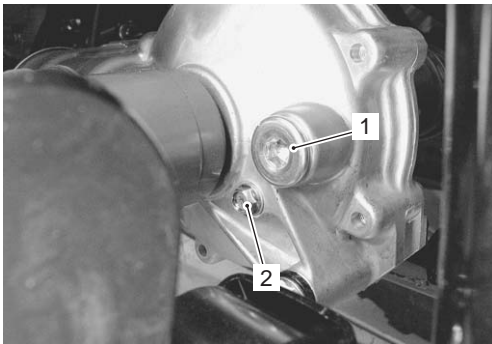

I827H1020014-01

- 4) Drain front differential gear oil by removing the oil drain plug (3).

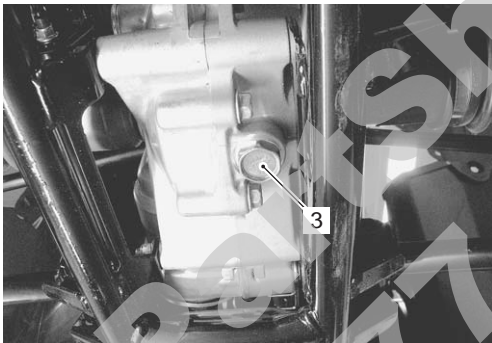

I827H1020015-01

- 5) Tighten the oil drain plug (3) to the specified torque.

⚠ CAUTION

Replace the gasket washers with a new one.

Tightening torque

Front drive (differential) gear oil drain plug (a):
32 N·m (3.2 kgf-m, 23.0 lb-ft)

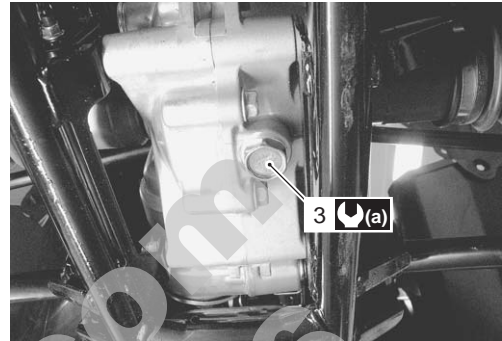

I827H1020016-01

- 6) Pour fresh oil through the oil filler hole until it overflows from the oil level hole. When performing an oil change, the front differential will hold about 300 ml (10.1/10.6 US/Imp oz) of oil. Use hypoid gear oil SAE #90, API grade GL-5.

NOTE

Use hypoid gear oil SAE #80, API grade GL-5, if the vehicle is ridden where the ambient temperature is below 0 °C (32 °F).

Front differential gear oil capacity
300 ml (10.1/10.6 US/Imp oz)

- 7) Tighten the oil level plug (2) and oil filler plug (1) to the specified torque.

⚠ CAUTION

Replace the gasket washers with new ones.

Tightening torque

Front drive (differential) gear oil level plug (b): 8 N·m (0.8 kgf-m, 6.0 lb-ft)

Front drive (differential) gear oil filler plug (c):
35 N·m (3.5 kgf-m, 25.5 lb-ft)

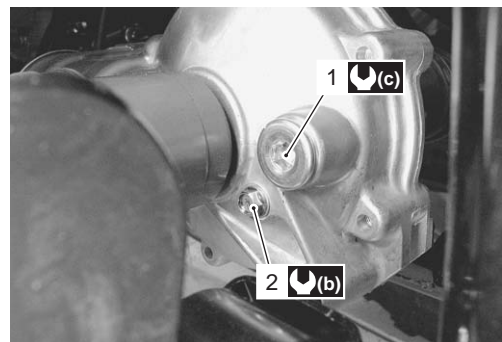

I827H1020017-01

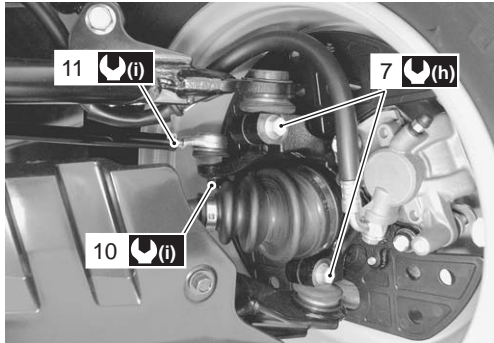

I827H1020057-02

7	(h)	Steering knuckle pinch bolt (Upper and lower) 50 N-m (5.0 kgf-m, 36.0 lb-ft)
10	(i)	Tie-rod end nut 29 N-m (2.9 kgf-m, 21.0 lb-ft)
11	(i)	Tie-rod lock nut 29 N-m (2.9 kgf-m, 21.0 lb-ft)

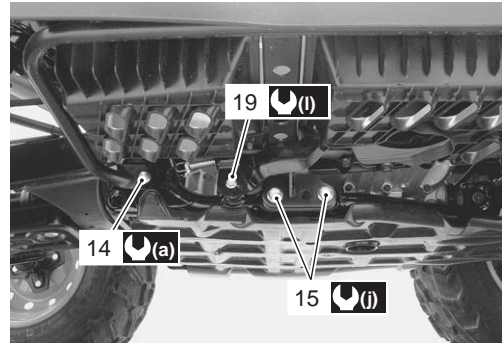

I827H1020060-02

14	(a)	Footrest bolt (M8) 25 N-m (2.5 kgf-m, 18.0 lb-ft)
15	(j)	Footrest bolt (M10) 55 N-m (5.5 kgf-m, 40.0 lb-ft)
19	(l)	Brake pedal bolt 12 N-m (1.2 kgf-m, 8.5 lb-ft)

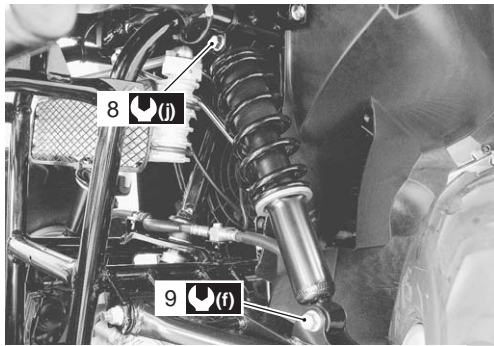

I827H1020058-02

8	(i)	Front shock absorber mounting bolt (Upper) 55 N-m (5.5 kgf-m, 40.0 lb-ft)
9	(i)	Front shock absorber mounting nut (Lower) 60 N-m (6.0 kgf-m, 43.5 lb-ft)

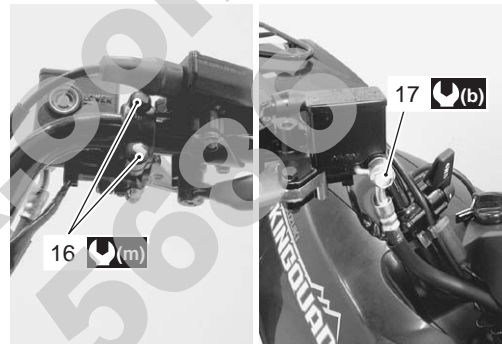

I827H1020061-02

16	(m)	Brake master cylinder mounting bolt 10 N-m (1.0 kgf-m, 7.0 lb-ft)
17	(b)	Brake hose union bolt 23 N-m (2.3 kgf-m, 16.5 lb-ft)

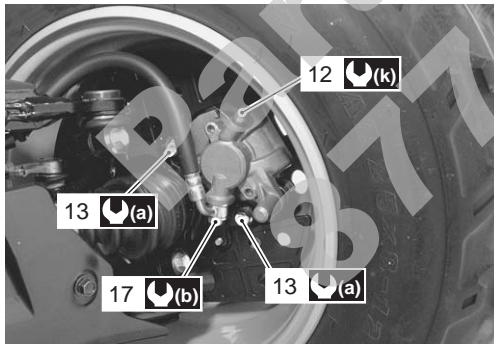

I827H1020059-02

12	(k)	Brake air bleeder valve 6 N-m (0.6 kgf-m, 4.5 lb-ft)
13	(a)	Brake caliper mounting bolt 26 N-m (2.6 kgf-m, 19.0 lb-ft)
17	(b)	Brake hose union bolt 23 N-m (2.3 kgf-m, 16.5 lb-ft)

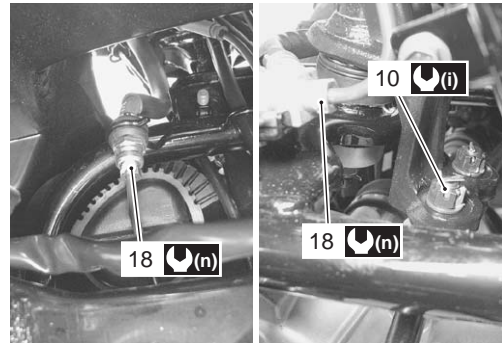

I827H1020062-02

10	(i)	Tie-rod end nut 29 N-m (2.9 kgf-m, 21.0 lb-ft)
18	(n)	Front brake pipe nut 16 N-m (1.6 kgf-m, 11.5 lb-ft)

Item		Standard	Limit
Transmission gear ratio	Low	3.083 (37/12)	—
	2nd	1.933 (29/15)	—
	3rd	1.388 (25/18)	—
	4th	1.095 (23/21)	—
	Top	0.913 (21/13)	—
	Reverse	2.833 (34/12)	—
Transmission shift fork to groove clearance		0.10 – 0.30 (0.004 – 0.012)	0.50 (0.020)
Transfer shift fork to groove clearance		0.10 – 0.30 (0.004 – 0.012)	0.50 (0.020)
Reverse Shift fork to groove clearance		0.10 – 0.30 (0.004 – 0.012)	0.50 (0.020)
Shift fork groove width	Transmission	4.50 – 4.60 (0.178 – 0.181)	—
	Transfer	5.50 – 5.60 (0.217 – 0.220)	—
	Reverse	5.00 – 5.10 (0.197 – 0.201)	—
Shift fork thickness	Transmission	4.30 – 4.40 (0.169 – 0.173)	—
	Transfer	5.30 – 5.40 (0.209 – 0.213)	—
	Reverse	4.80 – 4.90 (0.189 – 0.193)	—
Front/Rear output shaft bevel gear backlash		0.03 – 0.15 (0.001 – 0.006)	—
Front drive (differential) gear backlash		0.05 – 0.10 (0.002 – 0.004)	—
Final gear backlash		0.08 – 0.13 (0.0031 – 0.0051)	—

Engine Oil Temp. Switch + Cooling Fan Thermo-switch

Item	Standard/Specification		Limit
Engine oil temp. indicator light switch operating temperature	OFF → ON	Approx. 160 °C (320 °F)	—
	ON → OFF	Approx. 140 °C (284 °F)	—
Cooling fan thermo-switch operating temperature	OFF → ON	Approx. 120 °C (248 °F)	—
	ON → OFF	Approx. 110 °C (230 °F)	—

Carburetor

Item	Specification	
	P-17, 24, 28	P-33
Carburetor type	KEIHIN CVK 32	←
Bore size	32 mm (1.26 in)	←
I.D. No.	27H1	27H0
Idle r/min	1 500 ± 100 r/min	←
Float height	17.0 ± 1.0 mm (0.67 ± 0.04 in)	←
Main jet (M.J.)	# 125	←
Jet needle (J.N.)	NLVM	←
Needle jet (N.J.)	# 6	←
Slow jet (S.J.)	# 38	←
Pilot jet (P.J.)	2 – 1/8 turn back	PRE-SET
Throttle cable play	3.0 – 5.0 mm (0.12 – 0.20 in)	←
Starter cable play	0.5 – 1.0 mm (0.02 – 0.04 in)	←

Electrical

Unit: mm (in)

Item	Specification		Note
Spark plug	Type	NGK: CR7E DENSO: U22ESR-N	
	Gap	0.7 – 0.8 (0.028 – 0.031)	
Spark performance	Over 8 (0.3) at 1 atm.		
CKP sensor resistance	130 – 250 Ω		BI – G
CKP sensor peak voltage	4.0 V and more		(+): BI, (–): G
Ignition coil resistance	Primary	0.1 – 1.0 Ω	(+) Terminal – (–) Terminal
	Secondary	12 – 22 kΩ	Plug cap – (+) Terminal

Recoil Starter Assembly Removal and Installation	1I-13	Regulator / Rectifier Inspection	1J-10
Recoil Starter Disassembly and Assembly	1I-13	Battery Components	1J-11
Recoil Starter Inspection	1I-15	Battery Charging	1J-11
Specifications	1I-16	Battery Removal and Installation	1J-13
Service Data (LT-A400/F, LT-F400/F)	1I-16	Battery Visual Inspection.....	1J-13
Tightening Torque Specifications.....	1I-16	Specifications	1J-14
Special Tools and Equipment	1I-16	Service Data (LT-A400/F, LT-F400/F)	1J-14
Recommended Service Material	1I-16	Tightening Torque Specifications.....	1J-14
Special Tool	1I-17	Special Tools and Equipment	1J-14
Charging System	1J-1	Recommended Service Material	1J-14
Schematic and Routing Diagram	1J-1	Special Tool	1J-14
Charging System Diagram.....	1J-1	Exhaust System	1K-1
Component Location	1J-1	Precautions	1K-1
Charging System Components Location.....	1J-1	Precautions for Exhaust System	1K-1
Diagnostic Information and Procedures	1J-1	Repair Instructions	1K-1
Charging System Symptom Diagnosis.....	1J-1	Exhaust System Components.....	1K-1
Battery Runs Down Quickly	1J-2	Muffler / Exhaust Pipe Removal and Installation.....	1K-2
Repair Instructions	1J-3	Exhaust System Inspection.....	1K-3
Battery Current Leakage Inspection	1J-3	Spark Arrester Inspection.....	1K-3
Regulated Voltage Inspection	1J-3	Specifications	1K-4
Generator Inspection	1J-4	Tightening Torque Specifications.....	1K-4
Generator Removal and Installation	1J-5		

PartShark.com
877-999-5606

Air Cleaner Element Removal and Installation

B827H21406002

Removal

- 1) Remove the seat. Refer to "Exterior Parts Removal and Installation in Section 9D (Page 9D-3)".
- 2) Remove the air cleaner box cover (1).

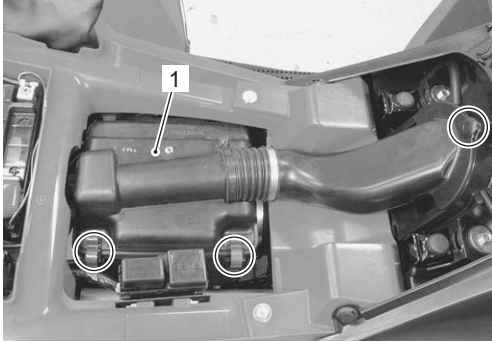

I827H1140227-02

- 3) Remove the air cleaner element bolt.
- 4) Remove the air cleaner element (2).

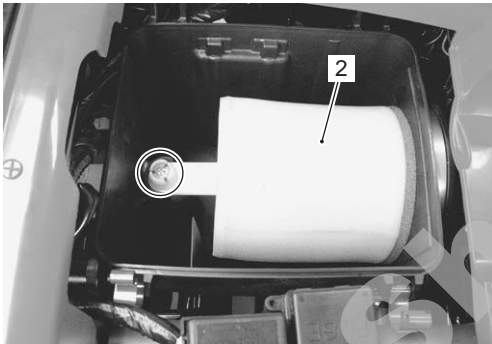

I827H1140228-02

Installation

Installation in the reverse order of removal.

Air Cleaner Element Inspection and Cleaning

B827H21406003

Refer to "Air Cleaner Element Inspection and Cleaning in Section 0B (Page 0B-3)".

Air Cleaner Box Removal and Installation

B827H21406004

Removal

- 1) Remove the rear fender. Refer to "Exterior Parts Removal and Installation in Section 9D (Page 9D-3)".
- 2) Remove the air cleaner box mounting bolts.

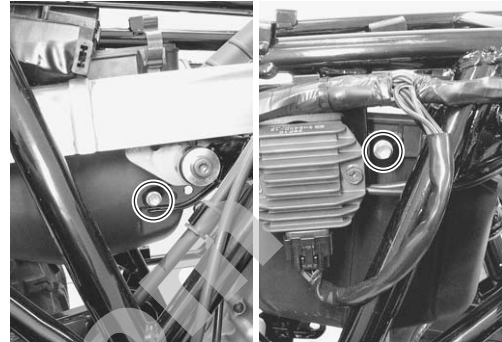

I827H1140229-01

- 3) Loosen the air cleaner box clamp screw and remove the air cleaner box (1).



I827H1140230-02

Installation

Install the air cleaner box in the reverse order of removal. Pay attention to the following points:

- Tighten the air cleaner box mounting bolts to the specified torque.

Tightening torque

Air cleaner box mounting bolt (a): 7 N·m (0.7 kgf-m, 5.0 lb-ft)

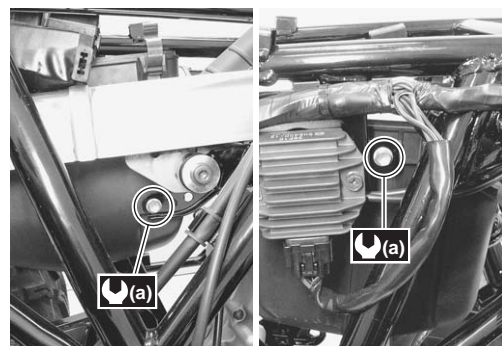

I827H1140231-01

- Install the removed parts.

- Tighten the cylinder head nuts to the specified torque.

Tightening torque

Cylinder head nut (8 mm) (Initial): 10 N·m (1.0 kgf-m, 7.0 lb-ft)

Cylinder head nut (8 mm) (Final): 25 N·m (2.5 kgf-m, 18.0 lb-ft)

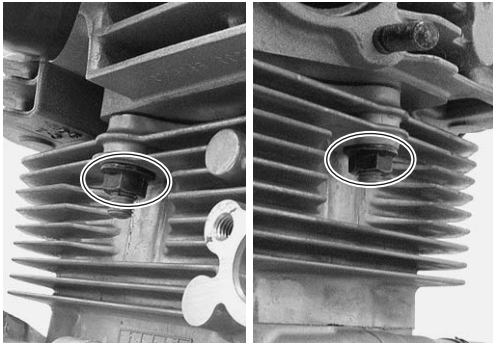

I827H1140024-01

- Tighten the cylinder base nuts to the specified torque.

Tightening torque

Cylinder base nut: 10 N·m (1.0 kgf-m, 7.0 lb-ft)



I827H1140025-01

Camshaft

- Align the line "A" on the generator rotor with the index mark "B" on the crankcase.

⚠ CAUTION

Pull the cam chain upward, or the chain will be caught between crankcase and cam drive sprocket.

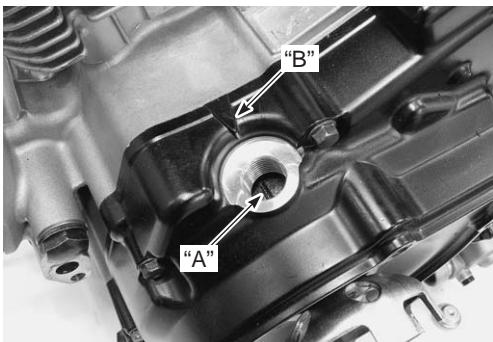

I827H1140026-01

- Install the C-ring (1) and cam chain tensioner (2).
- Install the camshaft and camshaft sprocket.

⚠ CAUTION

Install the camshaft sprocket so that the stamped mark side faces outside.

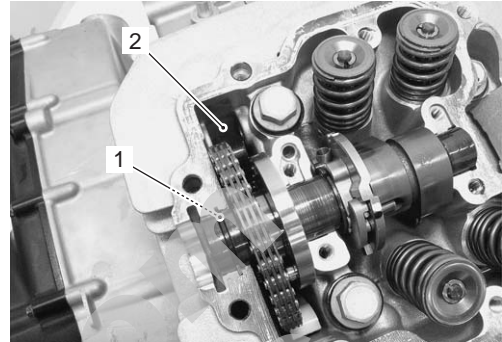

I827H1140027-01

- Align the marks "C" on the camshaft so that they are parallel with the surface of the cylinder head.
- Engage the hole of the camshaft sprocket with the locating pin "D" on the camshaft.

NOTE

Do not rotate the generator rotor while doing this. When the sprocket is not positioned correctly, turn the sprocket.

- Tighten the cam chain tensioner bolt (3).

Tightening torque

Cam chain tensioner bolt (a): 13 N·m (1.3 kgf-m, 9.5 lb-ft)

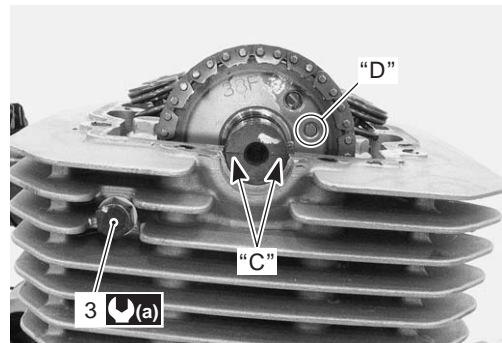

I827H1140028-01

Valve Stem Wear

If valve stem is worn down to the limit, as Measured with a micrometer. where the clearance is found to be in excess of the limit indicated replace the valve, if the stem is within the limit, then replace the guide. After replacing valve or valve guide, be sure to re-check the clearance.

Special tool

 : 09900-20205 (Micrometer (0 – 25 mm))

Valve stem O.D.

Standard (IN.): 4.975 – 4.990 mm (0.1959 – 0.1965 in)

Standard (EX.): 4.955 – 4.970 mm (0.1951 – 0.1957 in)



I827H1140064-01

Valve Stem End Condition

Inspect the valve stem end face for pitting and wear. If pitting or wear of the stem end face are present, the valve stem end may be resurfaced, providing that the length "A" will not be reduced to less than the service limit. If this length becomes less than the service limit, the valve must be replaced.

Valve stem end length

Service limit: 2.3 mm (0.09 in)

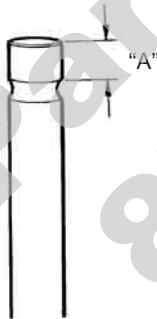

I827H1140065-01

Valve Spring

The force of the coil spring keeps the valve seat tight. A weakened spring results in reduced engine power output and often accounts for the chattering noise coming from the valve mechanism.

Check the valve springs for proper strength by measuring their free length and also by the force required to compress them. If the spring length is less than the service limit or if the force required to compress the spring does not fall within the specified range, replace the valve spring.

Special tool

 : 09900-20101 (Vernier calipers (1/15 mm, 150 mm))

Valve spring free length (IN. & EX.)

Service limit: 40.9 mm (1.61 in)

Valve spring tension (IN. & EX.)

Approx. 196 N (20.0 kgf, 44.1 lbs) at length 31.5 mm (1.24 in)

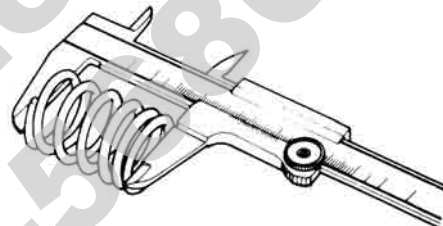

I827H1140066-01

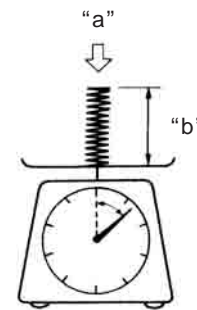

I827H1140067-01

Tension "a"	Length "b"
Approx. 196 N (20.0 kgf, 44.1 lbs)	31.5 mm (1.24 in)

Generator

Remove the generator component parts (1). Refer to "Generator Removal and Installation in Section 1J (Page 1J-5)".

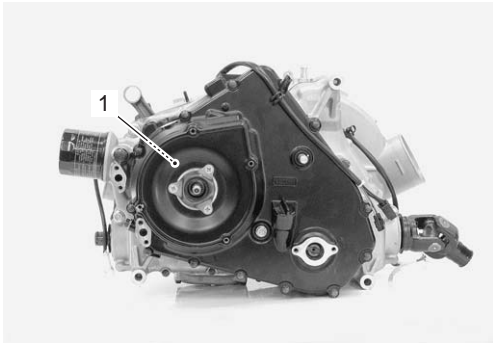

I827H1140099-01

Starter System

Remove the starter idle gear No.1, No.2, and starter driven gear. Refer to "Starter Clutch Removal and Installation in Section 1I (Page 1I-9)".



I827H1140100-02

Transfer Gearshift System

Remove the transfer gearshift related parts. Refer to "Transfer Gearshift Shaft No. 2 / Gearshift Cam Plate Removal and Installation (LT-A400/F) in Section 3C (Page 3C-17)".



I827H1140101-02

Transfer Drive Gear No.2

1) Remove the transfer drive gear No.2 (1) by removing the snap ring.

Special tool

 : 09900-06107 (Snap ring pliers)



I827H1140103-02

2) Remove the spacer (2).

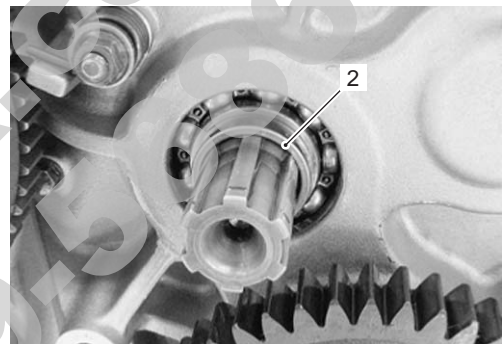

I827H1140254-02

Oil Filter

Remove the oil filter with the special tool.

Special tool

 (A): 09915-40610 (Oil filter wrench)

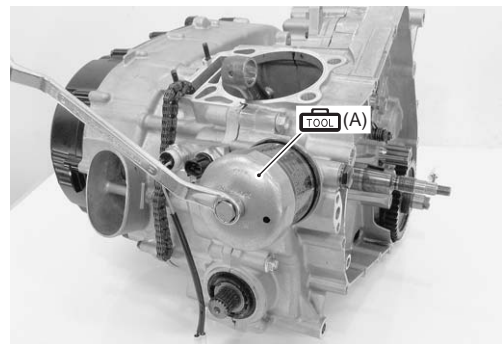

I827H1140105-01

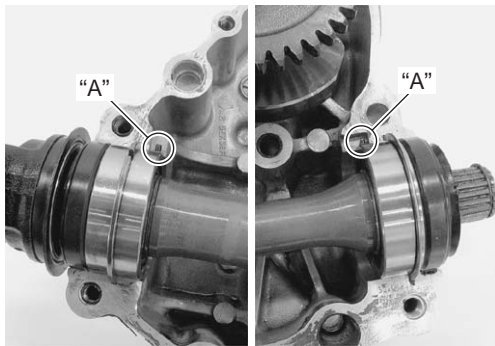

I827H1140156-01

- Install the washers (4), bearing (5) and gearshift shaft (6).
- Install the washer (7).

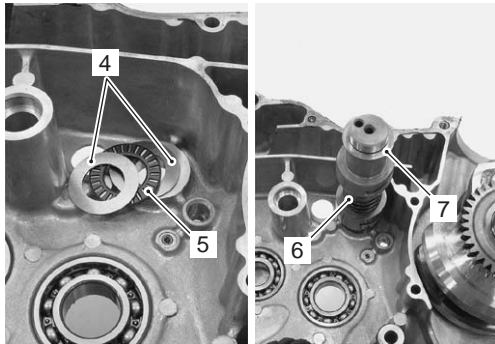

I827H1140157-01

- Install the gearshift forks (8) (9) and transfer output shaft assembly (10).

NOTE

Each gearshift fork has own embossed letters.

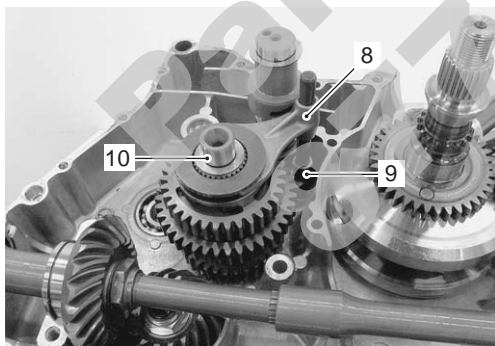

I827H1140158-01

"A": 44D-TL (For reverse gear)
"B": 44D-TM (For High/Low gear)

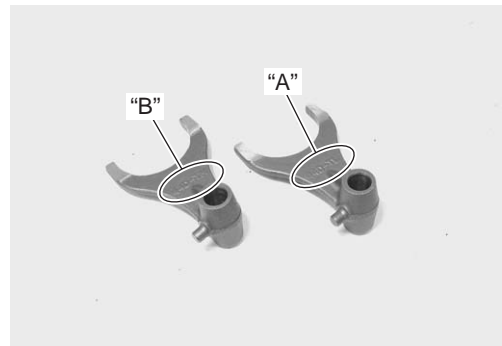

I827H1140262-01

- Install the transfer input shaft assembly (11).

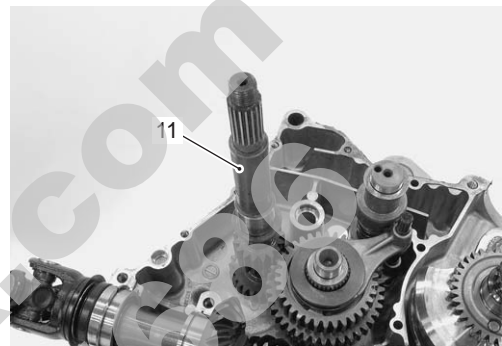

I827H1140159-01

- Install the shaft (12), spacer (13) and bearing (14).
- Install the reverse idle gear (15) and washer (16).

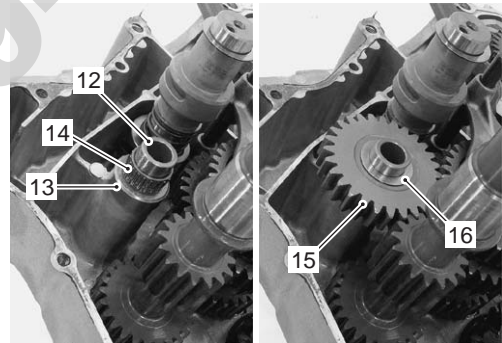

I827H1140160-01

Crankcase

- Wipe the crankcase mating surfaces (both surfaces) with a cleaning solvent.
- Fit the dowel pins onto the left half on the crankcase.
- Apply engine oil to the conrod big end the gears.

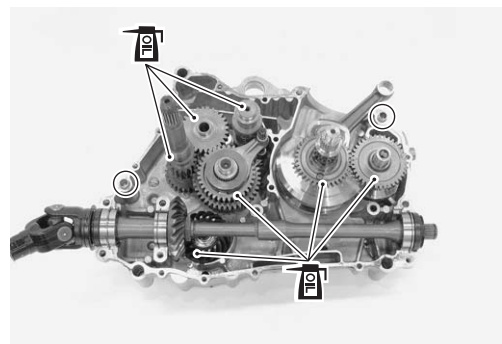

I827H1140161-01

Oil Filter

- Install the oil filter with the special tool. Refer to “Engine Oil and Filter Replacement in Section 0B (Page 0B-7)”.

Special tool

 (A): 09915-40610 (Oil filter wrench)

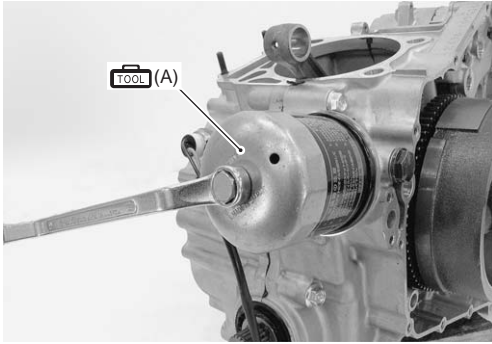

I827H1140201-01

Cam Chain

Install the cam chain (1).

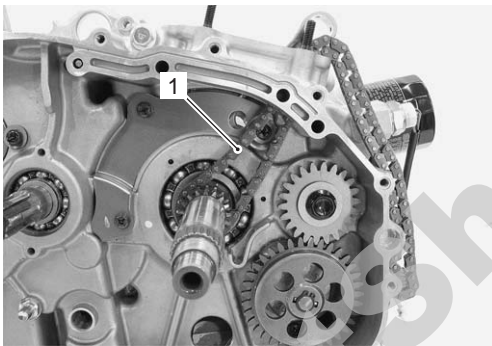

I827H1140202-01

Gearshift

- Install the gearshift cam plate (1).



I827H1140203-01

- Install the spring to the gearshift cam shaft properly.

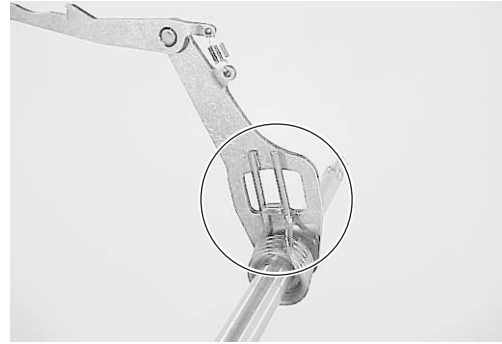

I827H1520029-01

- Install the gearshift cam shaft assembly while aligning the spring ends with the stopper pin.

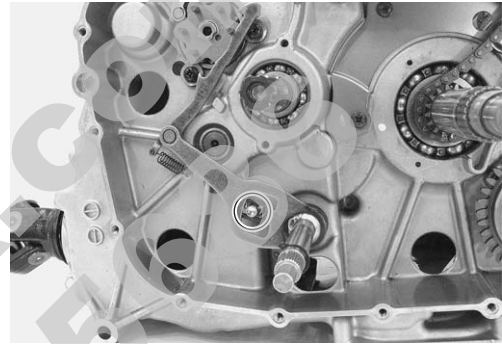

I827H1140204-01

- Install the gearshift cam plate guide (2).

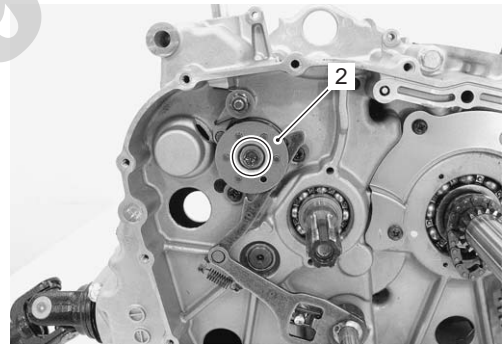

I827H1140205-01

Clutch

install the clutch component parts (1). Refer to “Clutch Removal and Installation (LT-F400/F) in Section 5C (Page 5C-3)”.

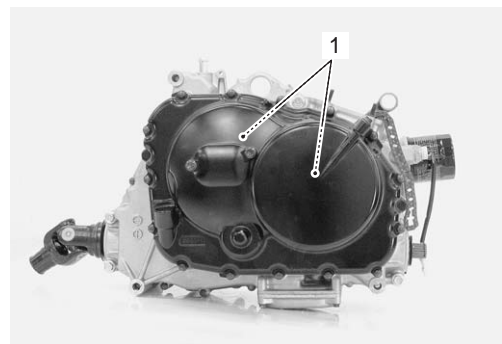

I827H1140206-01

LT-F400/F left crankcase

1) Install the bearings with the special tool.

⚠ CAUTION

Use the suitable size attachment for each bearing.

Special tool

TOOL (A): 09913-70210 (Bearing installer set)

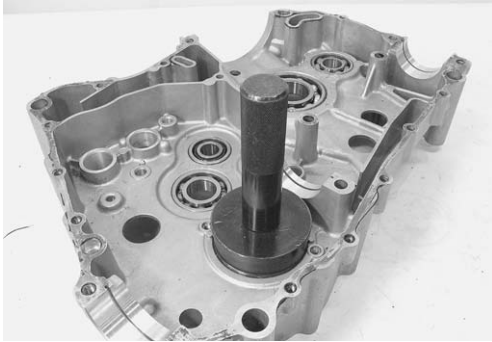

I827H1140302-02

2) Apply thread lock to the screws, and tighten them.

1322 : Thread lock cement 99000-32110 (THREAD LOCK CEMENT SUPER 1322 or equivalent)

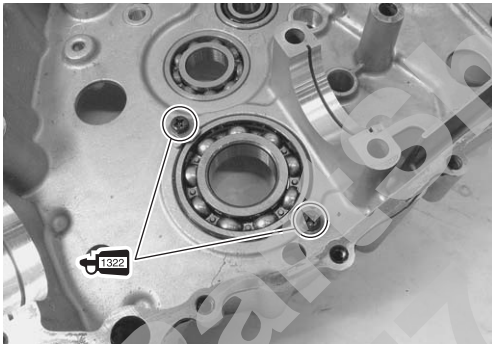

I827H1140303-02

LT-A400/F Generator cover

⚠ CAUTION

The removed bearings and oil seals must be replaced with new ones.

Special tool

TOOL (A): 09913-70210 (Bearing installer set)

- Install the bearing with the special tool.

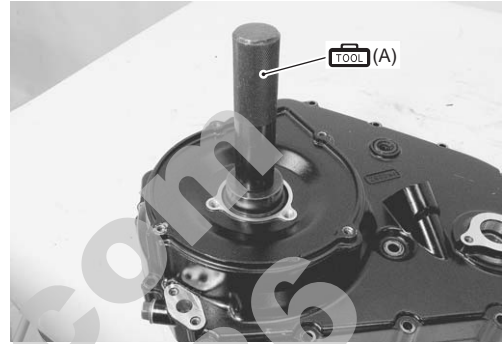

I827H1140292-02

- Install the bearings with the special tool.

Special tool

TOOL (A): 09913-70210 (Bearing installer set)

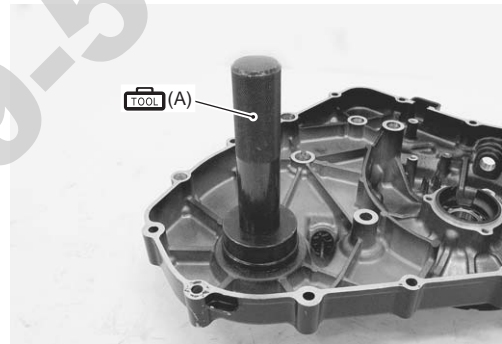

I827H1140293-04

LT-F400/F

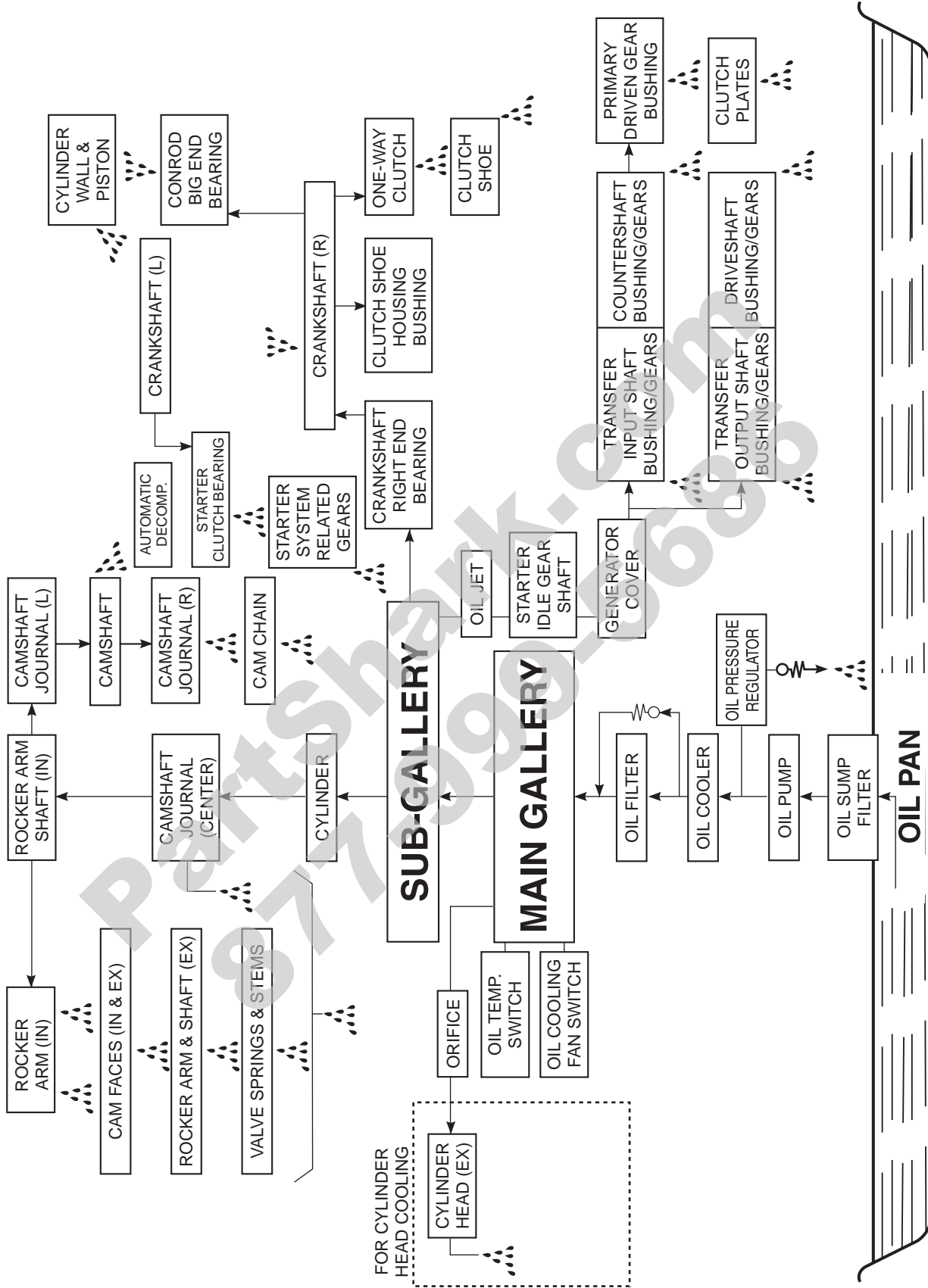

Cooling Fan Components

B827H21506013

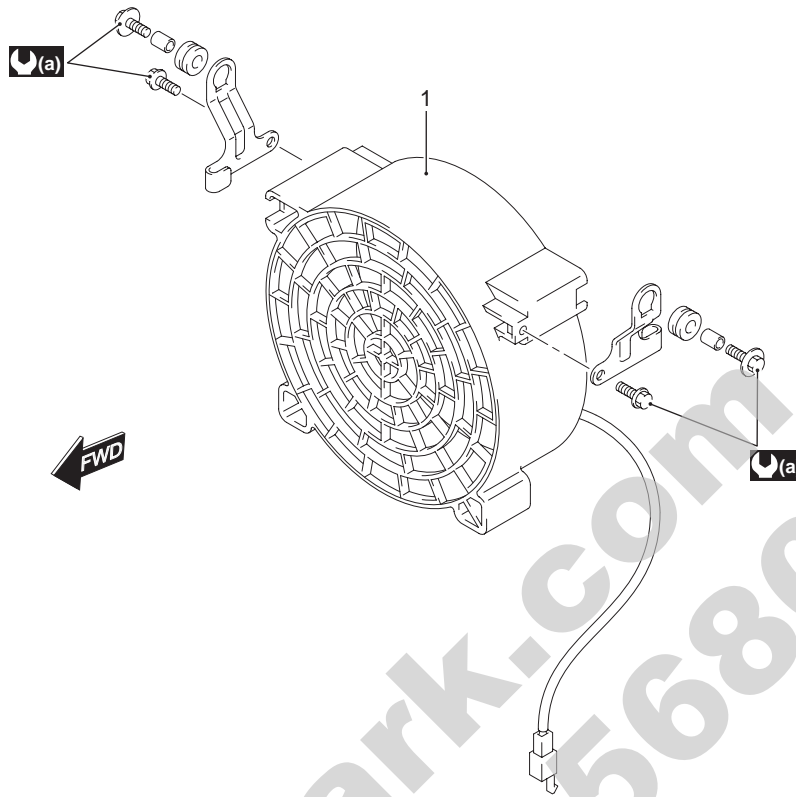

1. Cooling fan assembly	(a) : 10 N·m (1.0 kgf·m, 7.0 lb·ft)
-------------------------	-------------------------------------

I827H1150049-01

Cooling Fan Inspection

B827H21506014

Inspect the cooling fan in the following procedures:

- 1) Remove the left inner fender. Refer to "Exterior Parts Removal and Installation in Section 9D (Page 9D-3)".
- 2) Disconnect the cooling fan motor lead wire coupler (1).

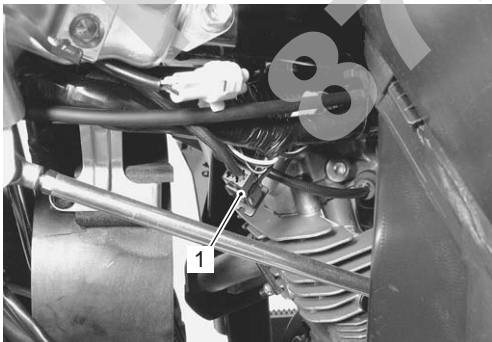

I827H1150034-01

- 3) Test the cooling fan motor for load current with an ammeter connected as shown in the figure. If the fan motor does not turn, replace the cooling fan assembly with a new one. Refer to "Cooling Fan Removal and Installation (Page 1E-13)".

NOTE

- When making this test, it is not necessary to remove the cooling fan.
- The voltmeter is for making sure that the battery applies 12 V to the motor. With the fan motor with electric motor fan running at full speed, the ammeter should be indicating not more than 8 A.

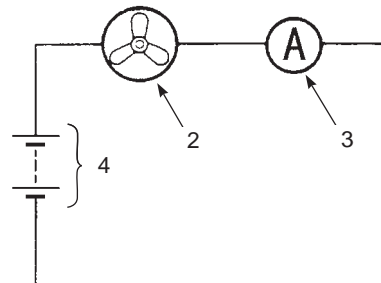

I718H1160048-01

- 4) Connect the cooling fan motor coupler.

Diaphragm and Piston Operation

The carburetor is a variable-venturi type, whose venturi cross sectional area is increased or decreased automatically by the piston valve (1). The piston valve moves according to the negative pressure present on the downstream side of the venturi "A". Negative pressure "B" is admitted into the diaphragm chamber (2) through an orifice "C" provided in the piston valve (1).

Rising negative pressure overcomes the spring (3) force, causing the piston valve (1) to rise into the diaphragm chamber and prevent the air velocity from increasing. Thus, air velocity in the venturi passage is kept relatively constant for improved fuel atomization and the precise air/fuel mixture.

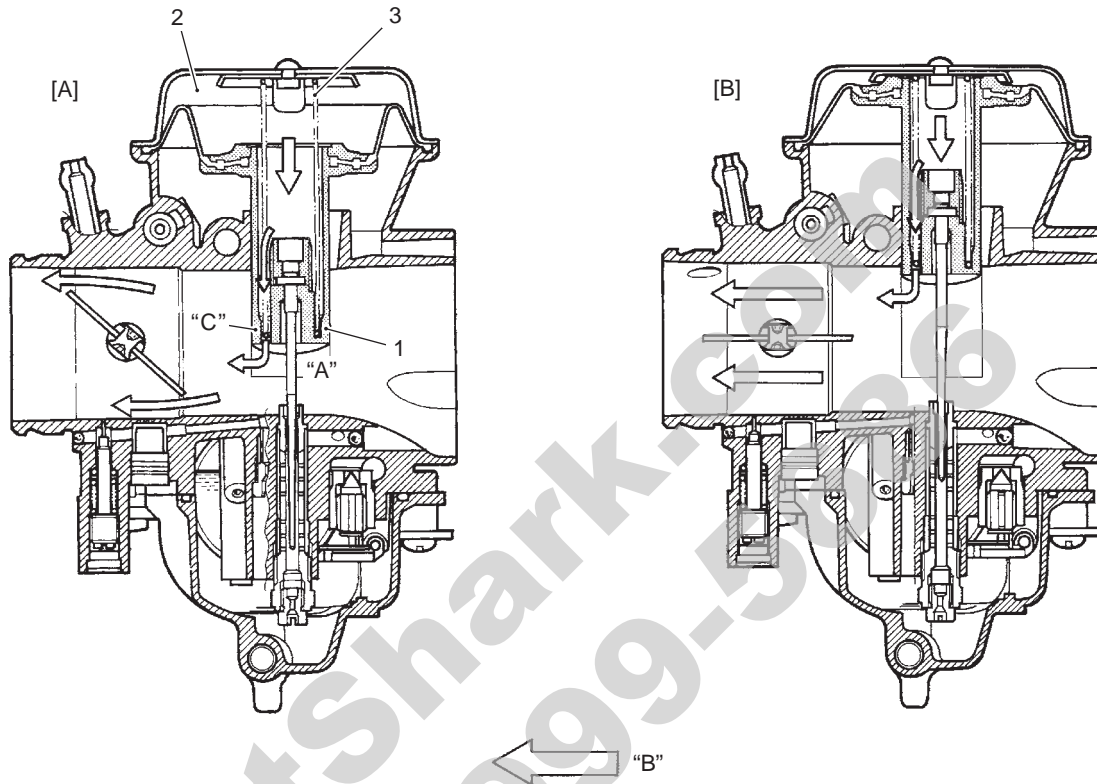

I827H1170035-02

1. Piston valve	3. Spring	"B": Negative pressure	[A]: Lower position of piston valve
2. Diaphragm chamber	"A": Venturi	"C": Orifice	[B]: Upper position of piston valve

Installation

Install the fuel valve in the reverse order of removal. Pay attention to the following points:

▲ WARNING

Replace the gasket washers (1) and gasket (2) with new ones to prevent fuel leakage.

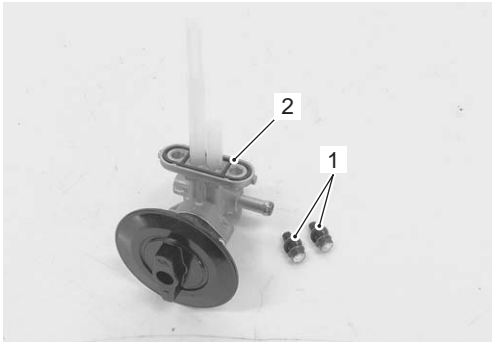

I827H1170022-02

- Tighten the fuel valve bolts to the specified torque.

Tightening torque

Fuel valve bolt: 4.6 N·m (0.46 kgf·m, 3.5 lb-ft)

Fuel Filter Inspection and Cleaning

B827H21706004

Inspect and clean the fuel filter in the following procedures:

- 1) Remove the fuel tank. Refer to “Fuel Tank Removal and Installation (Page 1G-13)”.
- 2) Remove the fuel valve. Refer to “Fuel Valve Removal and Installation (Page 1G-13)”.
- 3) Check the fuel filter for sediment or rust. If the fuel filter is dirty with sediment or rust, fuel will not flow smoothly and loss in engine power may result. Clean the fuel filter with compressed air.



I827H1170023-01

- 4) Reinstall the fuel valve. Refer to “Fuel Valve Removal and Installation (Page 1G-13)”.
- 5) Reinstall the fuel tank. Refer to “Fuel Tank Removal and Installation (Page 1G-13)”.

Fuel Level Gauge Removal and Installation

B827H21706005

Removal

▲ WARNING

Gasoline is very explosive. Extreme care must be taken.

- 1) Remove the fuel tank upper cover. Refer to “Fuel Tank Removal and Installation (Page 1G-13)”.
- 2) Remove the fuel level gauge cap (1).

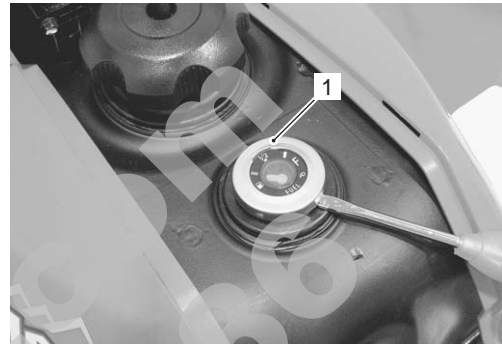

I827H1170024-01

- 3) Remove the fuel level gauge (2).

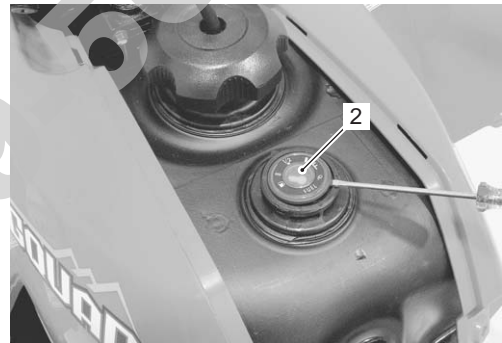

I827H1170026-01

Installation

Install the fuel level gauge in the reverse order of removal. Pay attention to the following points:

- When installing the fuel level gauge, “1/2” indication must be faced to forward.



I827H1170025-01

Ignition System

Schematic and Routing Diagram

Ignition System Diagram

B827H21802001

Refer to "Wire Color Symbols in Section 0A (Page 0A-4)".

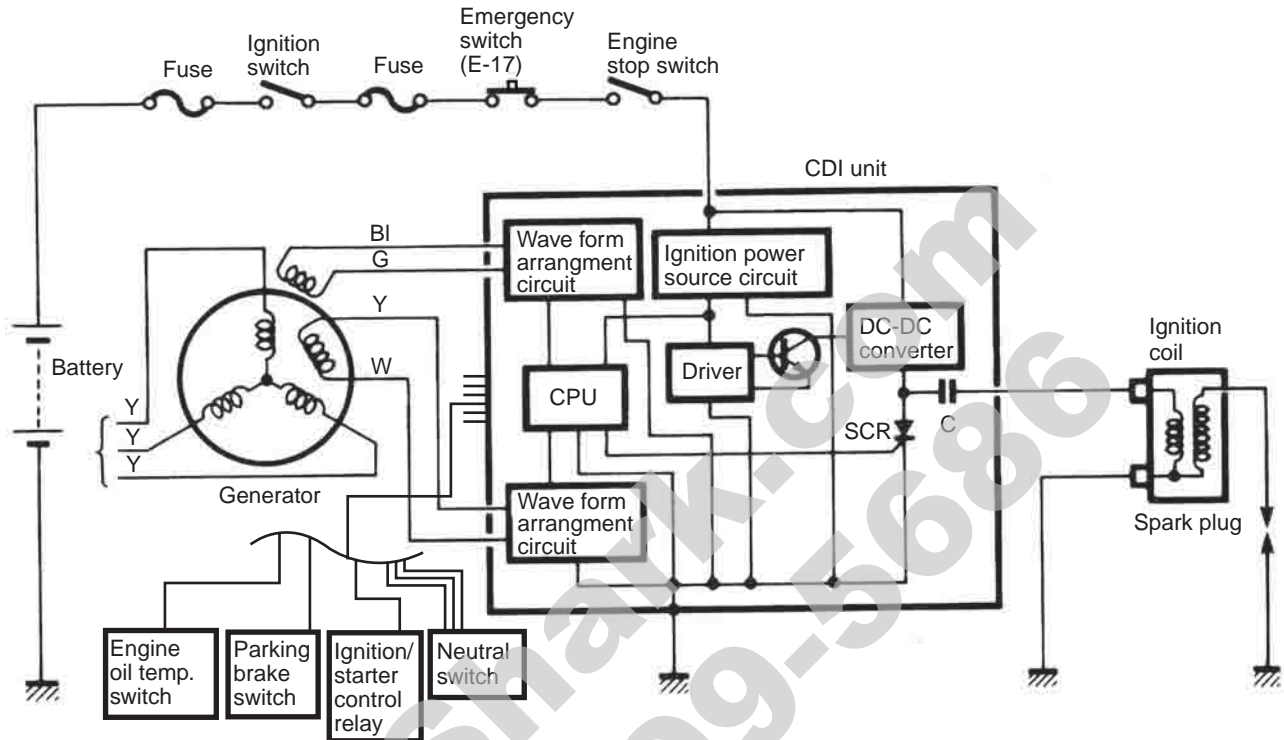

I827H1180007-01

Ignition System Components Location

B827H21802002

Refer to "Electrical Components Location in Section 0A (Page 0A-6)".

Diagnostic Information and Procedures

Ignition System Symptom Diagnosis

B827H21804001

Condition	Possible cause	Correction / Reference Item
Spark plug not sparking	Damaged spark plug.	Replace.
	Damaged spark plug cap.	Replace.
	Fouled spark plug.	Clean or replace.
	Wet spark plug.	Clean and dry or replace.
	Defective ignition coil.	Replace.
	Open or short in high-tension cord.	Replace.
	Defective CKP sensor.	Replace.
	Defective CDI unit.	Replace.
Engine stalls easily (No spark)	Fouled spark plug.	Clean or replace.
	Defective CKP sensor.	Replace.
	Defective CDI unit.	Replace.
Spark plug is wet or quickly becomes fouled with carbon	Excessively rich air/fuel mixture.	Adjust Carburetor.
	Excessively high idling speed.	Adjust Carburetor.
	Incorrect gasoline.	Change.
	Dirty air cleaner element.	Clean or replace.
	Incorrect spark plug (Cold type).	Change to hot type spark plug.

- Tighten the starter motor mounting bolts (1) with the engine ground lead wire (2) and starter motor lead wire mounting nut (3) to the specified torque. Refer to "Wiring Harness Routing Diagram in Section 9A (Page 9A-8)".

Tightening torque

Starter motor mounting bolt (a): 10 N·m (1.0 kgf-m, 7.0 lb-ft)

Starter motor lead wire mounting nut (b): 7 N·m (0.7 kgf-m, 5.0 lb-ft)

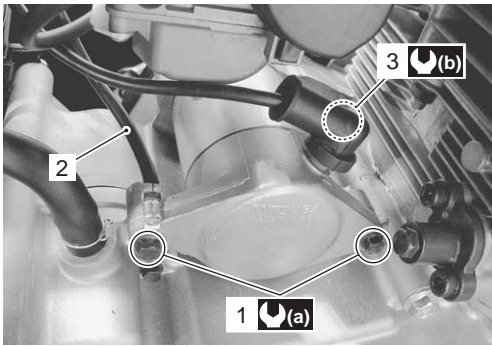

I827H1190005-01

Starter Motor Disassembly and Assembly

B827H21906003

Refer to "Starter Motor Removal and Installation (Page 11-3)".

Disassembly

Disassemble the starter motor as shown in the starter motor components diagram. Refer to "Starter Motor Components (Page 11-3)".

Assembly

Reassemble the starter motor in the reverse order of removal. Pay attention to the following points:

⚠ CAUTION

Replace the O-rings with new ones to prevent oil leakage and moisture.

- Apply grease to the lip of the oil seal.

🔧: Grease 99000-25010 (SUZUKI SUPER GREASE A or equivalent)



I827H1190006-01

- Apply a small quantity of moly paste to the armature shaft.

🔧: Moly paste 99000-25140 (SUZUKI Moly paste or equivalent)

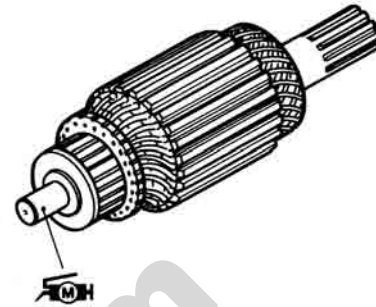

I827H1190008-01

- Align the match mark on the starter motor case with the match mark on the housing end.
- Tighten the starter motor housing bolts.

Tightening torque

Starter motor housing bolt (a): 3.5 N·m (0.35 kgf-m, 2.5 lb-ft)

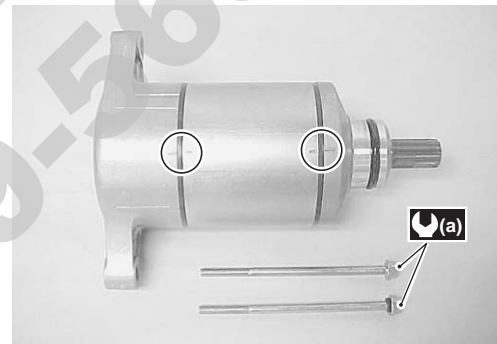

I827H1190007-01

Starter Motor Inspection

B827H21906004

Refer to "Starter Motor Disassembly and Assembly (Page 11-4)".

4) Disengage the rope (9) from the handle (10).

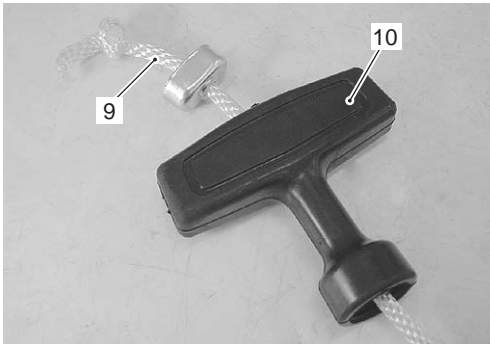

I831G1190052-02

5) Hook the rope to groove "A" of the reel (11).

6) Turn the rope on the reel (11) properly.

7) Remove the reel (11).



I831G1190053-02

8) Remove the spiral spring (12).

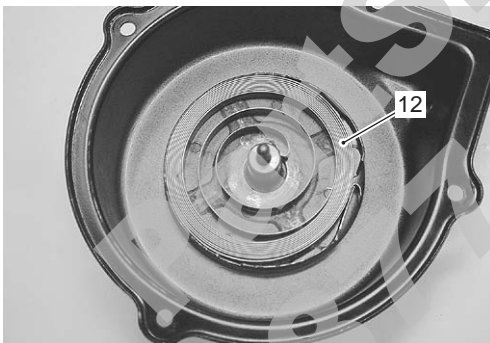

I831G1190054-01

Assembly

Assemble the recoil starter in the reverse order of disassembly. Pay attention to the following points:

▲ WARNING

Wear hand and eye protection when installing the reel, since the spring may quickly unwind and cause an injury.

- When installing the spiral spring, hook the spiral spring end "A" with the recoil starter case as shown in the figure.
- Apply grease to the spiral spring.

 **Grease 99000-25010 (SUZUKI SUPER GREASE A or equivalent)**

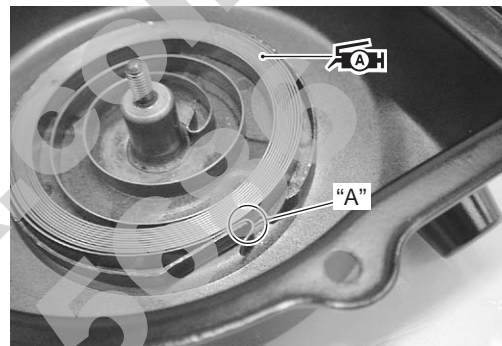

I831G1190055-01

- Turn the rope on the reel properly.
- After installing the spiral spring, engage the part "B" of the reel with the spiral spring end "C".

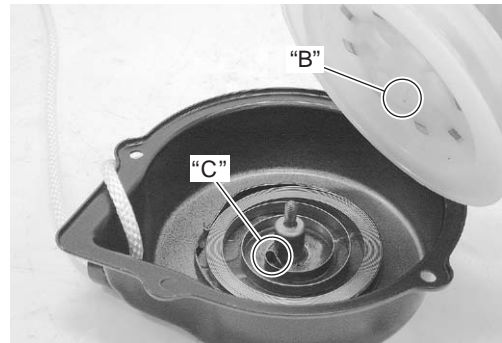

I831G1190056-01

- Hook the rope onto the hook part "D" of the reel, turn the reel clockwise five or six times with the rope.

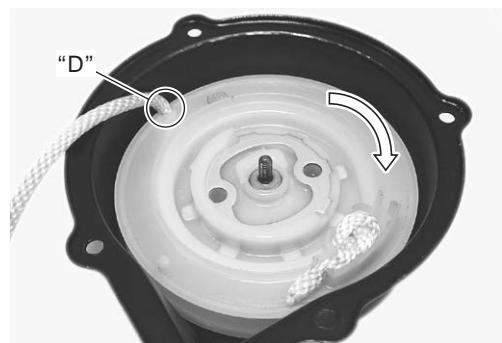

I831G1190057-01

- 18) Remove the generator stator (15) along with the CKP sensor (16).

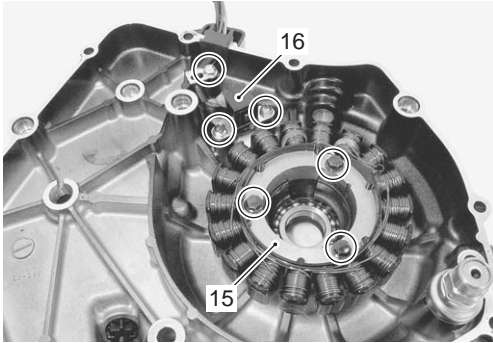

I827H11A0033-01

Installation

Install the generator in the reverse order of removal. Pay attention to the following points:

- Tighten the generator stator set bolts and CKP sensor mounting bolts to the specified torque.

NOTE

Be sure the grommet (1) is set to the generator cover.

Tightening torque

Generator stator set bolt (a): 11 N·m (1.1 kgf·m, 8.0 lb·ft)

CKP sensor mounting bolt (b): 6 N·m (0.6 kgf·m, 4.3 lb·ft)

Generator lead wire clamp bolt (c): 6 N·m (0.6 kgf·m, 4.3 lb·ft)

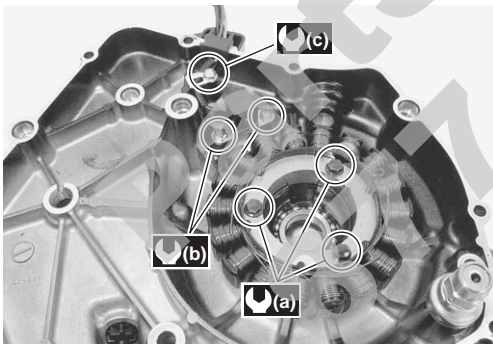

I827H11A0034-01

- Degrease the tapered portion “A” of generator rotor assembly and “B” of the crankshaft. Use nonflammable cleaning solvent to wipe off oily or greasy matter to make these surfaces completely dry.
- Fit the key (2) in the key slot on the crankshaft.
- Install the generator rotor assembly onto crankshaft.

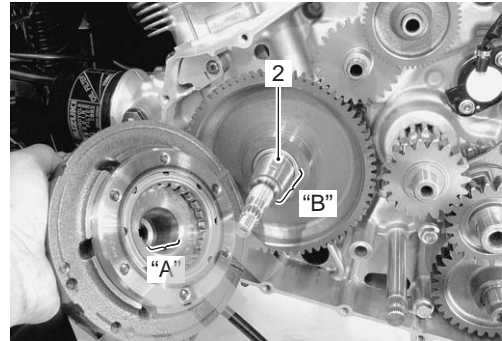

I827H11A0019-01

- Hold the generator rotor with the special tool and tighten the generator rotor nut to the specified torque.

Special tool

 (A): 09930-44541 (Rotor holder)

Tightening torque

Generator rotor nut: 140 N·m (14.0 kgf·m, 101.0 lb·ft)

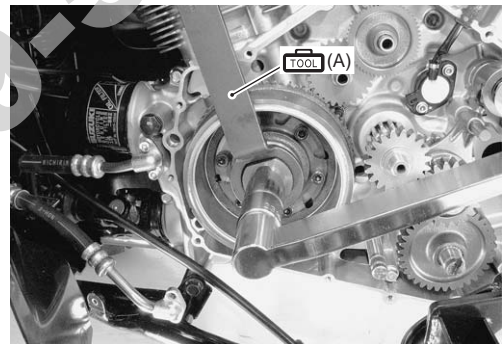

I827H11A0020-01

⚠ CAUTION

Make sure that the starter driven gear on the crankshaft is fitted into the generator rotor properly.

Muffler / Exhaust Pipe Removal and Installation

B827H21B06002

Removal

- 1) Remove the right inner fender. Refer to "Exterior Parts Removal and Installation in Section 9D (Page 9D-3)".
- 2) Remove the rear fender. Refer to "Exterior Parts Removal and Installation in Section 9D (Page 9D-3)".
- 3) Loosen the muffler connecting bolt (1).

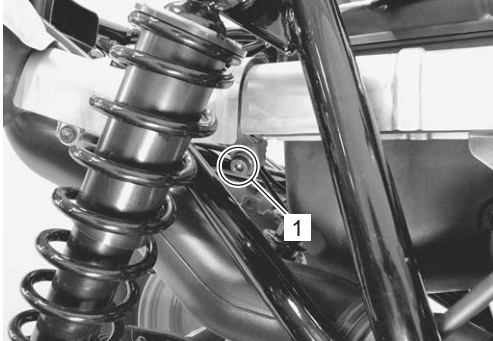

I827H11B0001-01

- 4) Remove the muffler (2).

NOTE

Support the muffler to prevent it from falling.



I827H11B0002-01

- 5) Remove the exhaust pipe (3).

NOTE

Support the exhaust pipe to prevent it from falling.



I827H11B0003-01

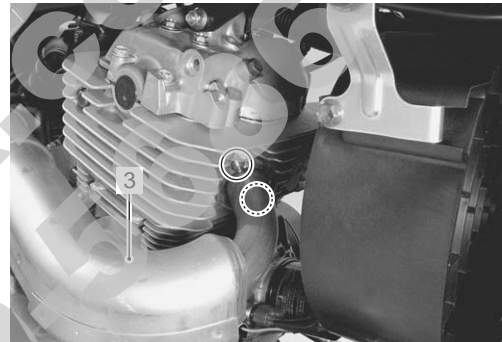

I827H11B0004-01

Installation

Install the exhaust pipe/muffler in the reverse order of removal.

Pay attention to the following points:

- Install new exhaust pipe gasket (1) and connector (2).

⚠ CAUTION

Replace the removed gasket and connector with new ones.

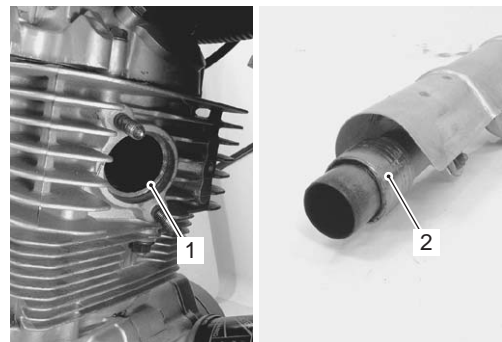

I827H11B0005-01

5) Remove the front disc cover (6).

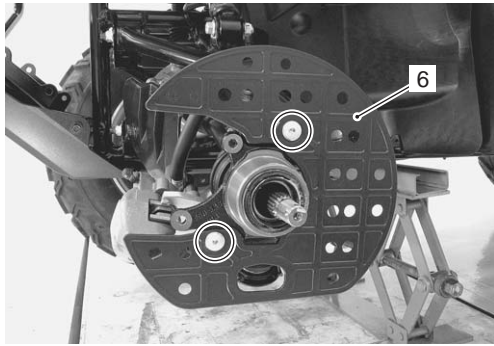

I827H1220006-01

6) Remove the cotter pin, tie-rod end nut and washer.



I827H1220007-01

7) Disengage the tie-rod end with the special tool.

⚠ WARNING

When using the tie-rod end remover, keep clear of the tie-rod end because it may come loose with some force and could strike you.

Special tool

 (A): 09942-72410 (Tie rod end remover)

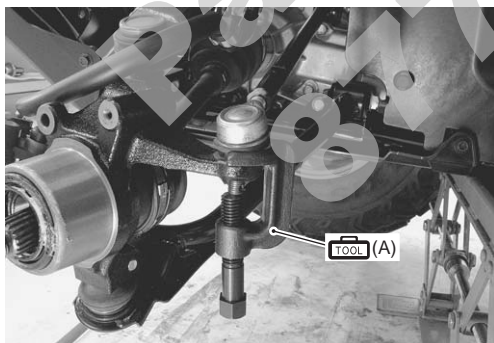

I827H1220008-01

8) Remove the knuckle pinch bolts.

9) Remove the steering knuckle (7).



I827H1220038-02

Installation

Install the steering knuckle in the reverse order of removal. Pay attention to the following points:

- Apply grease to the lip of dust seals.

 : Grease 99000-25010 (SUZUKI SUPER GREASE A or equivalent)



I827H1220009-01

- Apply thread lock to the steering knuckle pinch bolt and tighten them to the specified torque.

 : Thread lock cement 99000-32030 (THREAD LOCK CEMENT SUPER 1303 or equivalent)

Tightening torque

Steering knuckle pinch bolt (a): 50 N-m (5.0 kgf-m, 36.0 lb-ft)

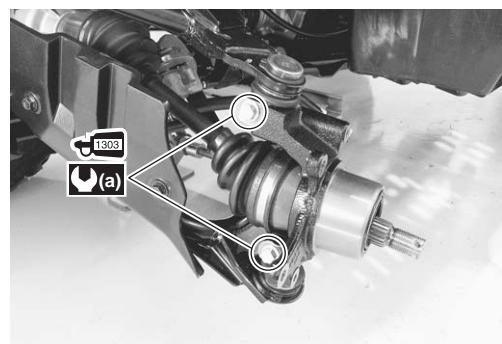

I827H1220039-01

CLICK HERE TO **DOWNLOAD** THE COMPLETE MANUAL

- Thank you very much for reading the preview of the manual.
- You can download the complete manual from: www.heydownloads.com by clicking the link below



- Please note: If there is no response to CLICKING the link, please download this PDF first and then click on it.

CLICK HERE TO **DOWNLOAD** THE COMPLETE MANUAL

Rear Suspension

Repair Instructions

Rear Suspension Components

B827H22306001

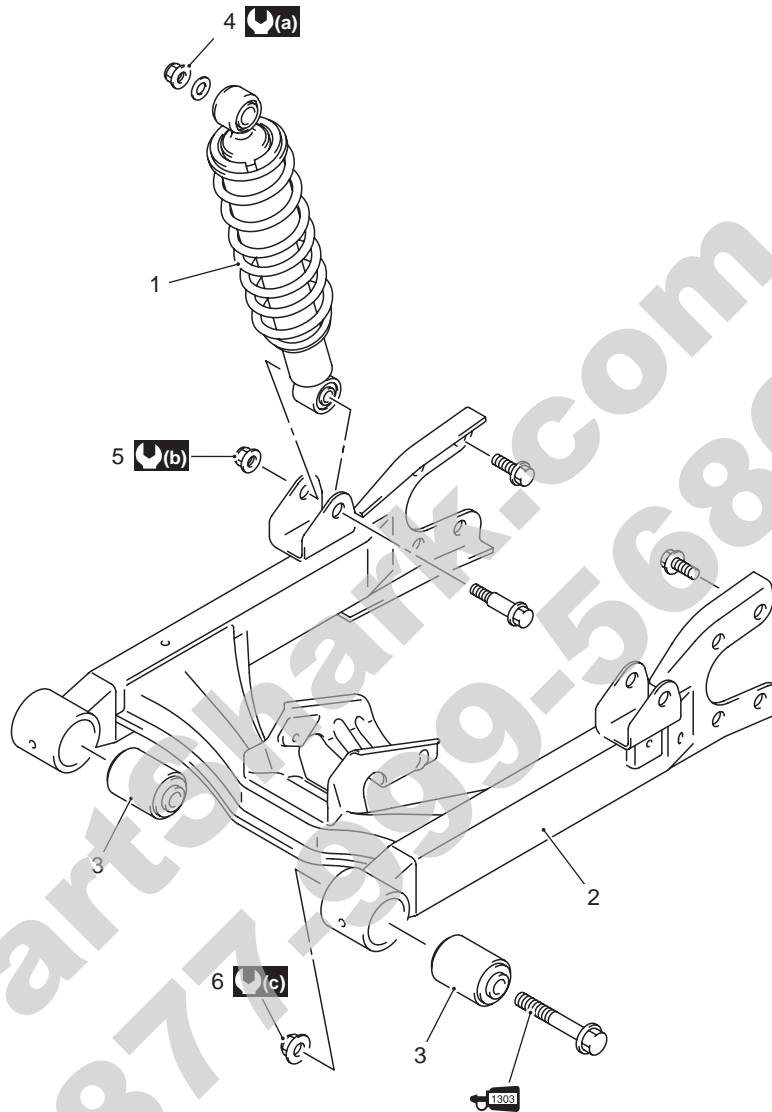

I827H1230011-01

1. Rear shock absorber	5. Rear shock absorber mounting lower nut	(c) : 102 N·m (10.2 kgf·m, 74.0 lb·ft)
2. Swingarm	6. Swingarm pivot nut	1303 : Apply thread lock to thread part.
3. Bushing	(a) : 35 N·m (3.5 kgf·m, 25.5 lb·ft)	: Do not reuse.
4. Rear shock absorber mounting upper nut	(b) : 60 N·m (6.0 kgf·m, 43.5 lb·ft)	

Section 3

Driveline / Axle

CONTENTS

Precautions	3-1		
Precautions	3-1		
Precautions for Driveline / Axle.....	3-1		
Drive Chain / Drive Train / Drive Shaft... 3A-1			
Diagnostic Information and Procedures	3A-1		
Drive Shaft Symptom Diagnosis.....	3A-1		
Repair Instructions	3A-1		
Front Drive Shaft Components (LT-A400F, LT-F400F).....	3A-1		
Front Drive Shaft Assembly Removal and Installation (LT-A400F, LT-F400F).....	3A-2		
Front Drive Shaft Disassembly and Assembly (LT-A400F, LT-F400F).....	3A-2		
Front Drive Shaft Inspection (LT-A400F, LT- F400F).....	3A-5		
Rear Axle Components.....	3A-6		
Rear Axle Construction.....	3A-7		
Rear Axle / Axle Housing Removal and Installation.....	3A-7		
Rear Axle / Axle Housing Inspection.....	3A-9		
Rear Axle housing Disassembly and Assembly.....	3A-10		
Specifications	3A-11		
Tightening Torque Specifications.....	3A-11		
Special Tools and Equipment	3A-11		
Recommended Service Material.....	3A-11		
Special Tool.....	3A-11		
Differential	3B-1		
Diagnostic Information and Procedures	3B-1		
Drive Train Symptom Diagnosis.....	3B-1		
Repair Instructions	3B-2		
Front Drive (Differential) Components (LT- A400F, LT-F400F).....	3B-2		
Front Drive (Differential) Construction (LT- A400F, LT-F400F).....	3B-3		
Front Drive (Differential) Gear Oil Level Inspection (LT-A400F, LT-F400F).....	3B-4		
Front Drive (Differential) Gear Oil Replacement (LT-A400F, LT-F400F).....	3B-4		
Front Drive (Differential) Assembly Removal and Installation (LT-A400F, LT-F400F).....	3B-4		
Front Drive (Differential) Assembly Disassembly and Assembly (LT-A400F, LT- F400F).....	3B-5		
Front Drive (Differential) Related Parts Inspection (LT-A400F, LT-F400F).....	3B-13		
Universal Joint Bearing / Pinion Gear Pilot Bearing Inspection.....	3B-14		
Front Drive (Differential) Gear Shim Inspection and Selection (LT-A400F, LT- F400F).....	3B-15		
Final Gear Components.....	3B-19		
Final Gear Construction.....	3B-20		
Final Gear Oil Level Inspection.....	3B-21		
Final Gear Oil Replacement.....	3B-21		
Final Gear Assembly Removal and Installation.....	3B-21		
Final Gear Assembly Disassembly and Assembly.....	3B-23		
Final Gear Related Parts Inspection.....	3B-28		
Final Gear Backlash Inspection and Shim Adjustment.....	3B-30		
Transfer Cable Inspection and Adjustment (LT-A400F, LT-F400F).....	3B-33		
Transfer Cable Removal and Installation (LT- A400F, LT-F400F).....	3B-33		
Specifications	3B-34		
Service Data (LT-A400/F, LT-F400/F).....	3B-34		
Tightening Torque Specifications.....	3B-34		
Special Tools and Equipment	3B-35		
Recommended Service Material.....	3B-35		
Special Tool.....	3B-35		
Transfer	3C-1		
Diagnostic Information and Procedures	3C-1		
Transfer Symptom Diagnosis (LT-A400/F).....	3C-1		
Transfer Symptom Diagnosis (LT-F400/F).....	3C-1		
Repair Instructions	3C-2		
Transfer Components (LT-A400/F).....	3C-2		
Transfer Components (LT-F400/F).....	3C-3		
Transfer Removal and Installation (LT-A400/ F).....	3C-4		
Transfer Removal and Installation (LT-F400/ F).....	3C-7		
Transfer Construction (LT-A400/F).....	3C-8		

- 5) Remove the rear axle housing mounting bolts (2).
- 6) Remove the trailer towing (3).
- 7) Remove the rear axle housing mounting bolt and nuts (4)

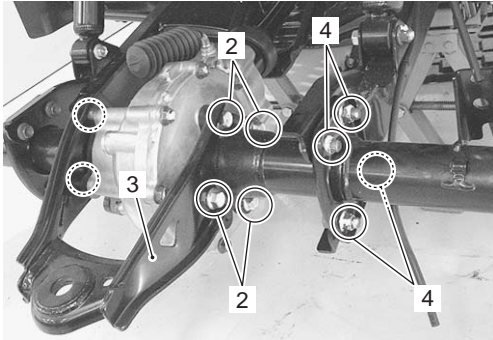

I827H1310006-02

- 8) Remove the rear axle housing (5) and rear axle (6).

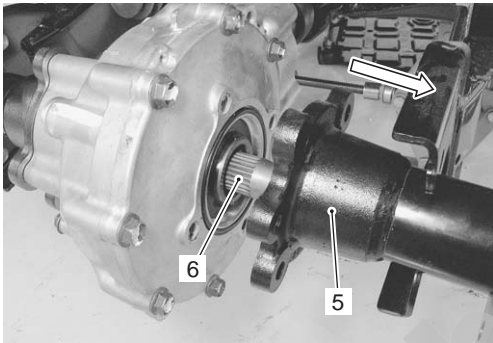

I827H1310007-02

- 9) Remove the O-ring (7).

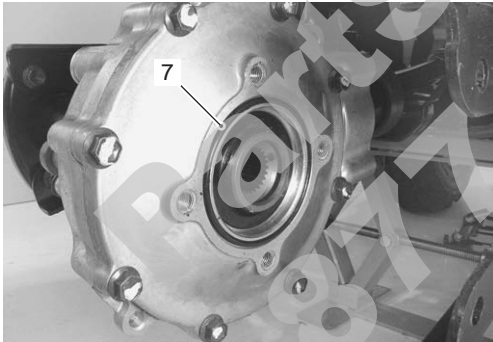

I827H1310008-02

Installation

Install the rear axle/axle housing in the reverse order of removal. Pay attention to the following points:

- Apply grease to the rear axle shaft spline.

 **Grease 99000-25010 (SUZUKI SUPER GREASE A or equivalent)**

NOTE

Overall length of RH axle shaft is shorter than LH axle shaft.



I827H1310012-01

- Install new O-ring to the rear drive gear case.

NOTE

Before installing the O-ring, apply grease to it.

 **Grease 99000-25010 (SUZUKI SUPER GREASE A or equivalent)**

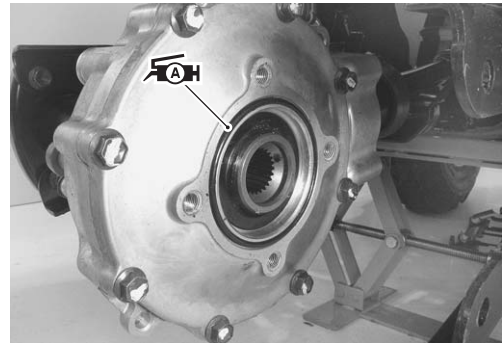

I827H1310013-01

2) Remove the front drive (differential) case cover (1).

NOTE

Use the special tool to remove the cover from housing if necessary.

Special tool

TOOL (A): 09912-34510 (Cylinder disassembling tool)

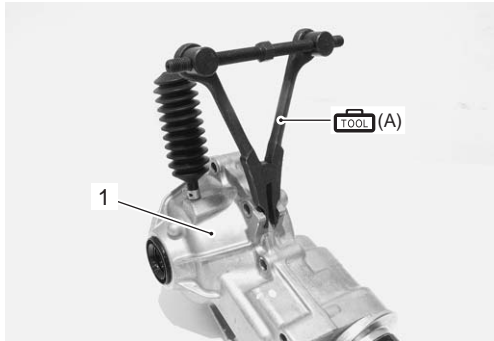

I827H1320010-01

3) Remove the front differential gear assembly (2) and shims (3).

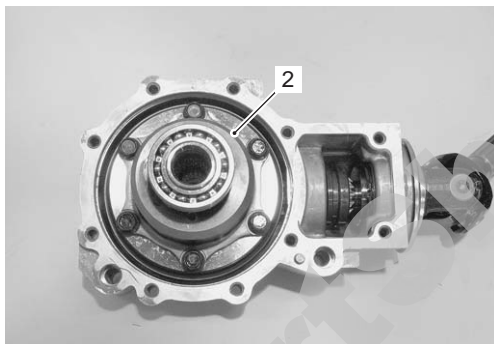

I827H1320011-01

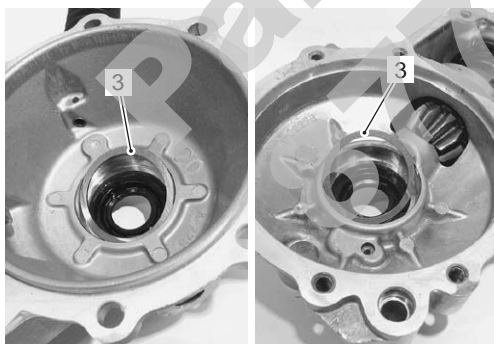

I827H1320012-01

4) Remove the bearings from the front differential gear assembly with a commercially available bearing puller.

NOTE

If there is no abnormal condition, the bearing removal is not necessary.

CAUTION

Do not attempt to disassemble the front differential gear assembly. The front differential gear is available only as an assembly.



I827H1320013-01

5) Remove the oil seals with the special tool.

Special tool

TOOL (B): 09913-50121 (Oil seal remover)

NOTE

If there is no abnormal condition, the oil seal removal is not necessary.

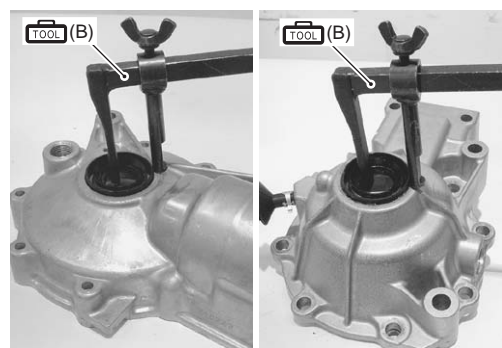

I827H1320014-01

5) Remove the dial gauge and turn the front drive (differential) gear 120°, then measure the backlash. Repeat this procedure once more and compare the difference of the three measurements. The backlash should be re-checked until the backlash is within specification. Check the table at the appropriate shim thickness. If the backlash is too small, replace the right side shim(-s) with a thicker one. If the backlash is too large, replace the right side shim(-s) with a thinner one. If the right side shim was changed with a 0.10 mm thicker shim, replace the left side shim with one that is 0.10 mm thinner.

NOTE

Adjust the backlash by referring to the table and using the thickness of the removed shims as a guide.

Backlash	Shim adjustment
Under 0.05 mm (0.0020 in)	Increase shim thickness
0.05 – 0.10 mm (0.0020 – 0.0040 in)	Correct
Over 0.10 mm (0.0040 in)	Decrease shim thickness

List of shims (for right side)

Part No.	Shim thickness
27445-38FA0 (Shim set: 16 pcs.)	0.70 mm (0.0276 in)
	0.75 mm (0.0295 in)
	0.80 mm (0.0315 in)
	0.85 mm (0.0335 in)
	0.90 mm (0.0354 in)
	0.95 mm (0.0374 in)
	1.00 mm (0.0394 in)
	1.05 mm (0.0413 in)
	1.10 mm (0.0433 in)
	1.15 mm (0.0453 in)
	1.20 mm (0.0472 in)
	1.25 mm (0.0492 in)
	1.30 mm (0.0512 in)
	1.35 mm (0.0531 in)
	1.40 mm (0.0551 in)
1.45 mm (0.0571 in)	

Left Side Shim Selection

- 1) Disassemble the front drive (differential) assembly. Refer to “Front Drive (Differential) Assembly Disassembly and Assembly (LT-A400F, LT-F400F) (Page 3B-5)”.
- 2) Install the right side shim(-s) and front drive (differential) gear assembly.

NOTE

Do not install the left side shim(-s) at this time.



I827H1320059-01

- 3) Put a few pieces of solder (O.D.: 1.2 – 1.5 mm (0.05 – 0.06 in) x L: 6 mm (0.24 in)) on the bearing outer race, as shown in the figure.



I827H1320060-02

Assembly

Assemble the final drive in the reverse order of disassembly. Pay attention to the following points:

⚠ CAUTION

The removed oil seals, O-rings and bearings must be replaced with new ones.

- Install the bearings into the final gear case and case cover with the special tool.

Special tool

TOOL (A): 09913-70210 (Bearing installer set)

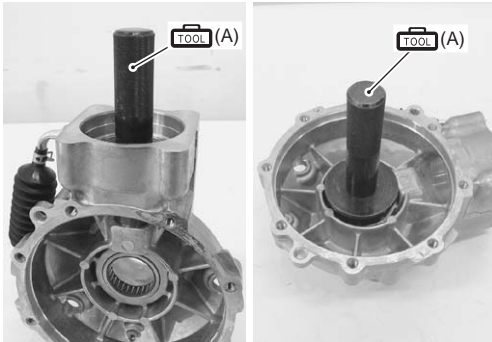

I827H1320088-01

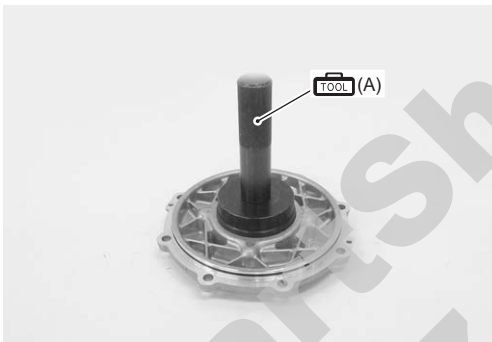

I827H1320089-01

- Install the spacer and bearing onto the shaft using a hydraulic.

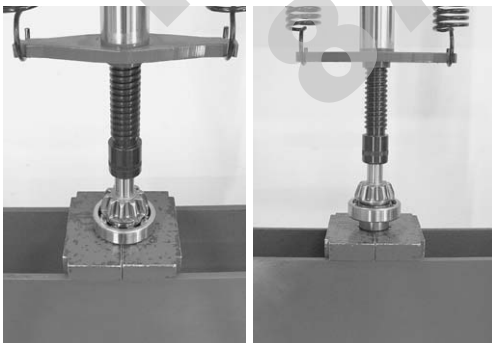

I827H1320090-02

⚠ CAUTION

The removed bearing must be replaced with a new one.

- Install new oil seals into the gear case and case cover with the special tool.
- Apply gear oil to the new oil seal lips.

Special tool

TOOL (A): 09913-70210 (Bearing installer set)

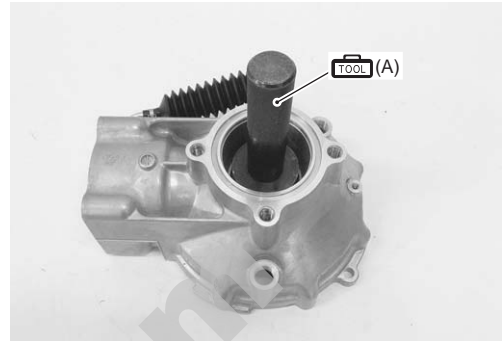

I827H1320091-01



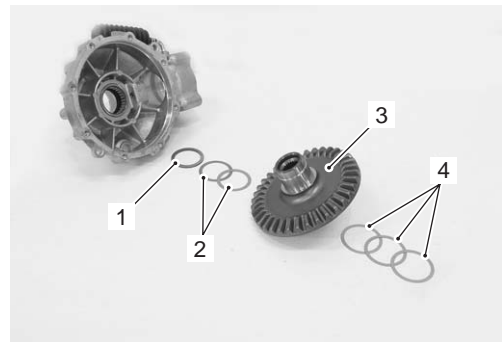

I827H1320092-01

- Place the washer (1) and shim(s) (2) on the gear case bearing (LH), then install the final drive gear (3) and shim(-s) (4).

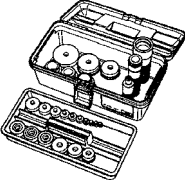
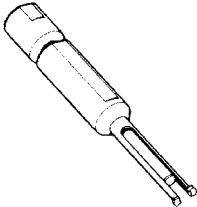
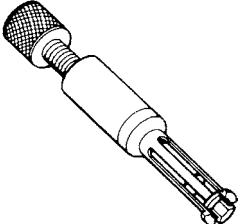
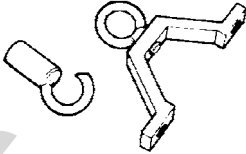
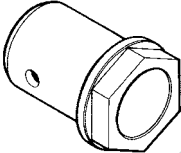
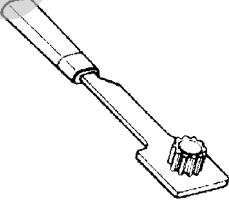
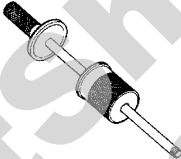

I827H1320093-01

<p>09913-70210 Bearing installer set ☞ (Page 3B-8) / ☞ (Page 3B-8) / ☞ (Page 3B-9) / ☞ (Page 3B-9) / ☞ (Page 3B-10) / ☞ (Page 3B-10) / ☞ (Page 3B-11) / ☞ (Page 3B-12) / ☞ (Page 3B-12) / ☞ (Page 3B-25) / ☞ (Page 3B-26) / ☞ (Page 3B-26)</p> 	<p>09921-20210 Bearing remover ☞ (Page 3B-8)</p> 
<p>09923-73210 Bearing remover ☞ (Page 3B-25)</p> 	<p>09924-21920 Wheel hub remover ☞ (Page 3B-7)</p> 
<p>09924-41830 Bearing retainer wrench ☞ (Page 3B-24) / ☞ (Page 3B-27) / ☞ (Page 3B-30)</p> 	<p>09924-64510 Final driving gear coupling holder ☞ (Page 3B-23) / ☞ (Page 3B-28)</p> 
<p>09930-30104 Rotor remover slide shaft ☞ (Page 3B-7) / ☞ (Page 3B-8) / ☞ (Page 3B-25)</p> 	<p>09941-64511 Bearing remover ☞ (Page 3B-25) / ☞ (Page 3B-25)</p> 

Transfer Gearshift Cam Components (LT-A400/F)

B827H23306008

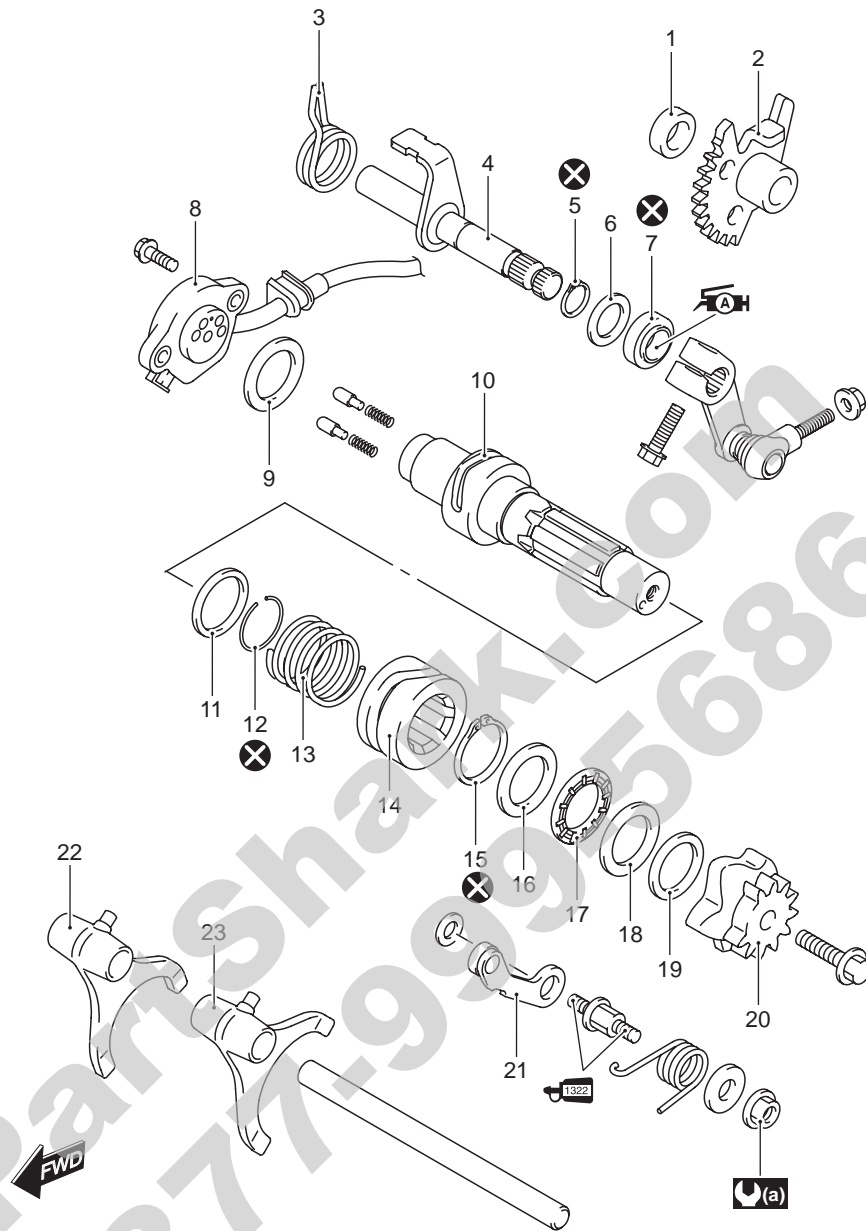

I827H1330027-03

1. Spacer	10. Transfer gearshift shaft No. 1	19. Washer
2. Transfer shift gear	11. Washer	20. Gearshift cam plate
3. Return spring	12. Circlip	21. Gearshift cam stopper
4. Transfer gearshift shaft No. 2	13. Spring	22. Gearshift fork (For reverse drive gears)
5. Snap ring	14. Transfer gearshift cam (For high/low gears)	23. Gearshift fork (For high/low gears)
6. Washer	15. Snap ring	Ⓐ: Apply grease.
7. Oil seal	16. Washer	1322: Apply thread lock.
8. GP switch	17. Bearing	ⓧ: Do not reuse.
9. Washer	18. Washer	ⓐ: 10 N-m (1.0 kgf-m, 7.0 lb-ft)

Transfer Range Lever Components (LT-A400/F)

B827H23306023

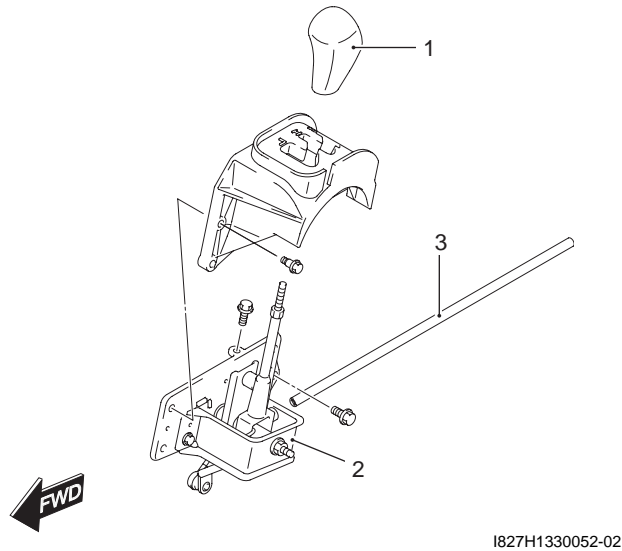

1. Shift knob
2. Transfer range lever assembly
3. Shift rod

Transfer Range Lever Components (LT-F400/F)

B827H23306024

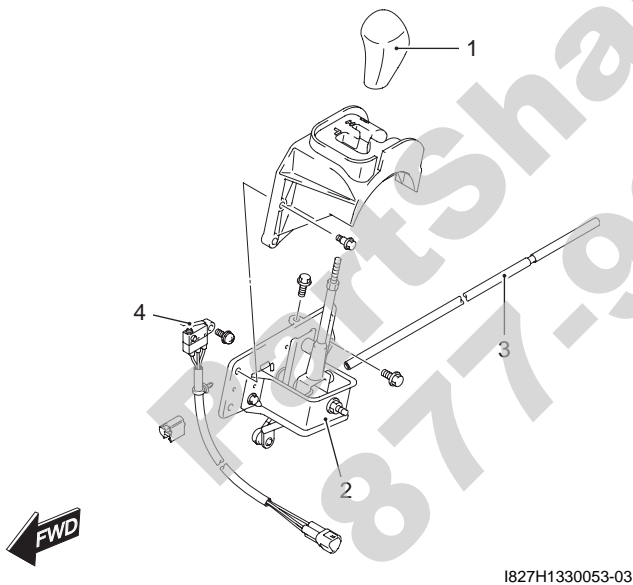

1. Shift knob
2. Transfer range lever assembly
3. Shift rod
4. Reverse switch (LT-F400F only)

Transfer Range Lever Removal and Installation

B827H23306025

Removal

- 1) Keep the vehicle on a level ground.
- 2) Remove the front fender. Refer to "Exterior Parts Removal and Installation in Section 9D (Page 9D-3)".
- 3) Remove the gearshift arm (1).

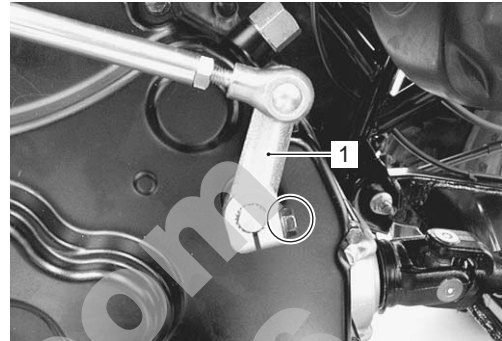

I827H1330054-01

- 4) Disconnect the reverse switch coupler (2) (LT-F400/F).
- 5) Remove the transfer range lever assembly (3) by removing the bolts.

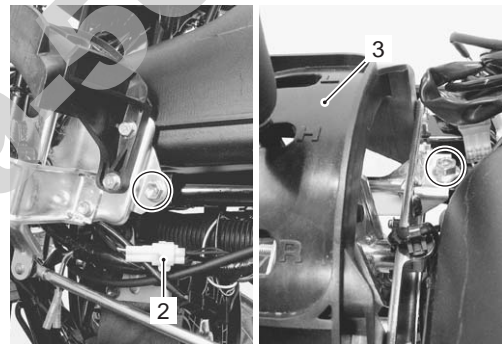

I827H1330055-02

Installation

Install the transfer range lever in the reverse order of removal. Pay attention to the following points:

- Apply grease to the lever pivot and spring.

⚠️ Grease 99000-25010 (SUZUKI SUPER GREASE A or equivalent)

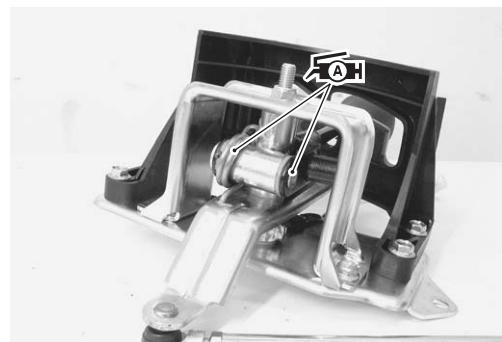

I827H1330056-01

- After reassembling the universal joint, check the joint movement smoothly. If a large resistance is felt to movement, tap the bearing with a plastic mallet lightly.

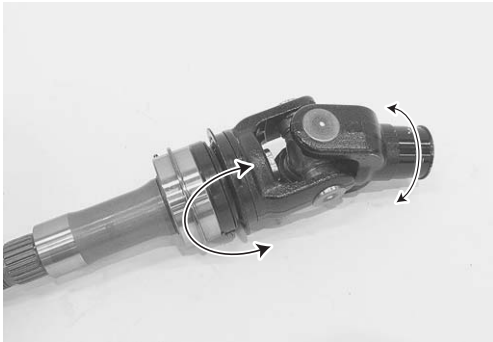

I827H1340032-01

- Install the bearing (4), driven bevel gear (5), washer and nut.

NOTE

The wider side “C” of the bearing should be positioned bevel gear side.

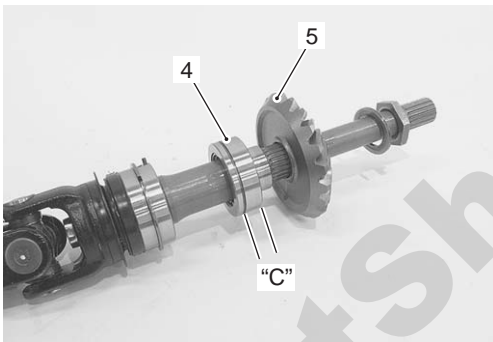

I827H1340033-02

- With the rear output shaft held immovable with a vise, tighten new nut to the specified torque.

Tightening torque

Driven bevel gear nut (a): 100 N·m (10.0 kgf·m, 72.5 lb-ft)

CAUTION

Replace the removed nut with a new one.



I827H1340034-01

- Stake the nut with a center punch.



I827H1340035-01

Rear Output Shaft Disassembly and Assembly (LT-F400/F)

B827H23406004

Refer to “Output Shaft Removal and Installation (Page 3D-3)”.

Disassembly

- 1) Using a chisel, unlock the nut.



I827H1340036-01

- 2) With the rear output shaft held immovable with a vise, remove the nut.



I827H1340037-01

2) Set the dial gauge on the drive bevel gear.

Special tool

TOOL (B): 09900-20607 (Dial gauge (1/100 mm, 10 mm))

TOOL (C): 09900-20701 (Magnetic stand)

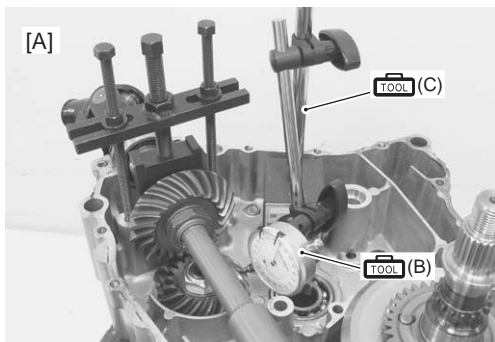

I827H1340081-01

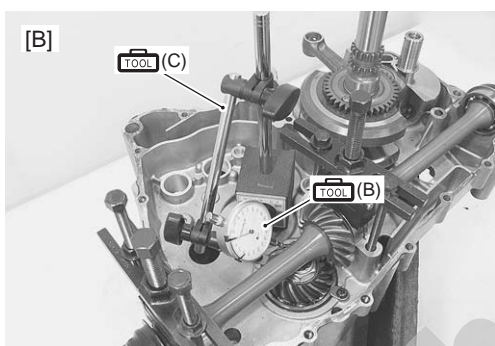

I827H1340080-01

[A]: LT-A400/F [B]: LT-F400/F

3) Measure the backlash by turning the drive bevel gear shaft in each direction, reading the total backlash with the dial gauge. If the backlash is not within specification, the shim must be changed and backlash should be re-checked until correct. Check the table at the appropriate shim thickness.

NOTE

Adjust the backlash by referring to the table at the using the thickness of the removed shims as a guide.

Rear output shaft bevel gear backlash

Standard: 0.03 – 0.15 mm (0.0001 – 0.006 in)

Backlash	Shim adjustment
Under 0.03 mm (0.001 in)	Decrease shim thickness
0.03 – 0.15 mm (0.001 – 0.006 in)	Correct
Over 0.15 mm (0.006 in)	Increase shim thickness

List of shims (for driven bevel gear)

Part No.	Shim thickness
24945-03G50-055	0.550 mm (0.022 in)
24945-03G50-058	0.575 mm (0.023 in)
24945-03G50-060	0.600 mm (0.024 in)
24945-03G50-063	0.625 mm (0.025 in)
24945-03G50-065	0.650 mm (0.026 in)
24945-03G50-068	0.675 mm (0.027 in)
24945-03G50-070	0.700 mm (0.028 in)
24945-03G50-073	0.725 mm (0.029 in)
24945-03G50-075	0.750 mm (0.030 in)
24945-03G50-078	0.775 mm (0.031 in)
24945-03G50-080	0.800 mm (0.031 in)
24945-03G50-083	0.825 mm (0.032 in)
24945-03G50-085	0.850 mm (0.033 in)
24945-03G50-088	0.875 mm (0.034 in)
24945-03G50-090	0.900 mm (0.035 in)
24945-03G50-093	0.925 mm (0.036 in)
24945-03G50-095	0.950 mm (0.037 in)
24945-03G50-098	0.975 mm (0.038 in)
24945-03G50-100	1.000 mm (0.039 in)
24945-03G50-103	1.025 mm (0.040 in)
24945-03G50-105	1.050 mm (0.041 in)
24945-03G50-108	1.075 mm (0.042 in)
24945-03G50-110	1.100 mm (0.043 in)
24945-03G50-113	1.125 mm (0.044 in)
24945-03G50-115	1.150 mm (0.045 in)
24945-03G50-118	1.175 mm (0.046 in)
24945-03G50-120	1.200 mm (0.047 in)
24945-03G50-123	1.225 mm (0.048 in)
24945-03G50-125	1.250 mm (0.049 in)
24945-03G50-128	1.275 mm (0.050 in)
24945-03G50-130	1.300 mm (0.051 in)
24945-03G50-133	1.330 mm (0.052 in)
24945-03G50-135	1.350 mm (0.053 in)
24945-03G50-138	1.380 mm (0.054 in)
24945-03G50-140	1.400 mm (0.055 in)

4) Check the tooth contact.

Precautions

Precautions

Precautions for Brake System

B827H2400001

Refer to "General Precautions in Section 00 (Page 00-1)".

Brake Fluid Information

B827H2400002

⚠ WARNING

- This brake system is filled with an ethylene glycol-based DOT 4 brake fluid. Do not use or mix different types of fluid, such as silicone-based or petroleum-based.
- Do not use any brake fluid taken from old, used or unsealed containers. Never reuse brake fluid left over from the last servicing or which has been stored for a long period of time.
- When storing brake fluid, seal the container completely and keep it away from children.
- When replenishing brake fluid, take care not to get dust into the fluid.
- When washing brake components, use new brake fluid. Never use cleaning solvent.
- A contaminated brake disc or brake pad reduces braking performance. Discard contaminated pads and clean the disc with high quality brake cleaner or neutral detergent.

⚠ CAUTION

Immediately and completely wipe off any brake fluid contacting any part of the vehicle. The brake fluid reacts chemically with paint, plastics and rubber materials, etc., and will damage them severely.



Front Brake Master Cylinder / Brake Lever Disassembly and Assembly

B827H24106015

Refer to "Front Brake Master Cylinder Assembly Removal and Installation (Page 4A-8)".

Disassembly

- 1) Remove the reservoir cap (1) and diaphragm (2).

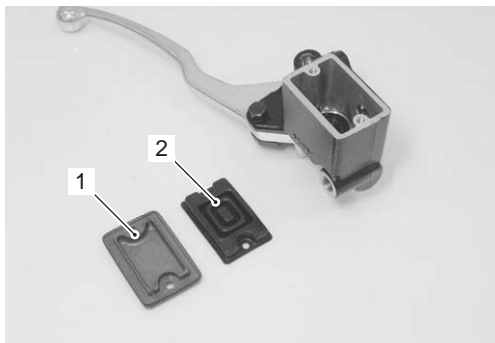

I827H1410025-01

- 2) Remove the brake lever (3) and brake light switch (4).

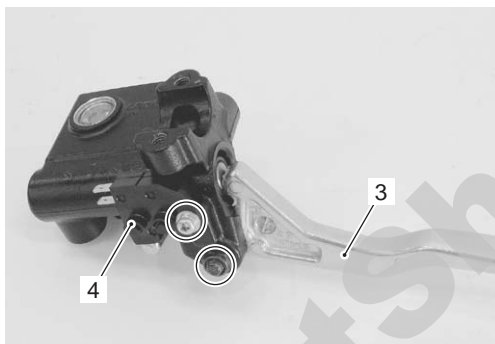

I827H1410026-01

- 3) Pull out the dust boot (5) and remove the snap ring (6).

Special tool

 : 09900-06108 (Snap ring pliers)

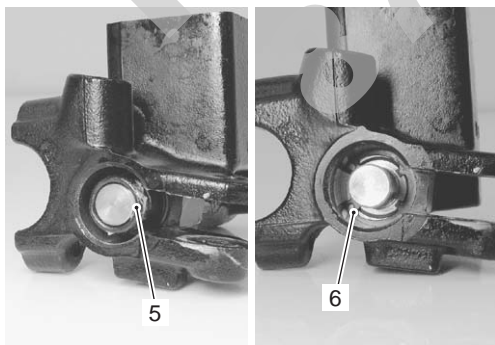

I827H1410027-01

- 4) Remove the following parts from the master cylinder.

- Secondary cup (7)
- Piston (8)
- Primary cup (9)
- Spring (10)

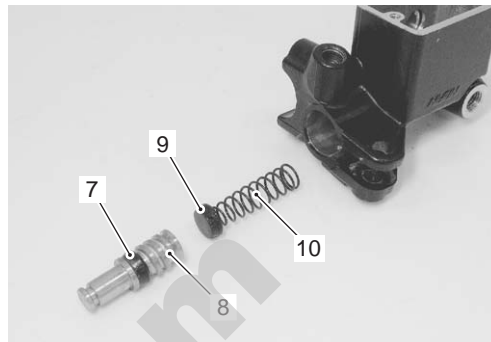

I827H1410028-01

Assembly

Assemble the master cylinder in the reverse order of disassembly. Pay attention to the following points:

CAUTION

- Wash the master cylinder components with new brake fluid before reassembly.
- Do not wipe the brake fluid off after washing the components.
- When washing the components, use the specified brake fluid. Never use different types of fluid or cleaning solvents such as gasoline, kerosine, etc.
- Apply brake fluid to the master cylinder bore and all of the master cylinder component to be inserted into the bore.

BF: Brake fluid (DOT 4)

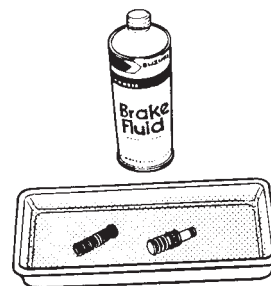

I649G1410024-02

- Install the piston seal as shown in the figure.

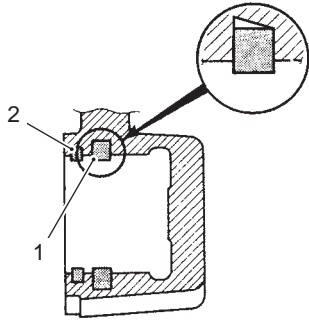

I649G1420013-02

- Apply thread lock to the caliper holder slide pin (3).
 - **1303** : Thread lock cement 99000-32030 (THREAD LOCK CEMENT SUPER 1303 or equivalent)
- Tighten the caliper holder slide pin nut (4) and caliper holder pin (5) to the specified torque.

Tightening torque

Caliper holder slide pin nut (a): 23 N-m (2.3 kgf-m, 16.5 lb-ft)

Caliper holder pin (b): 18 N-m (1.8 kgf-m, 13.0 lb-ft)

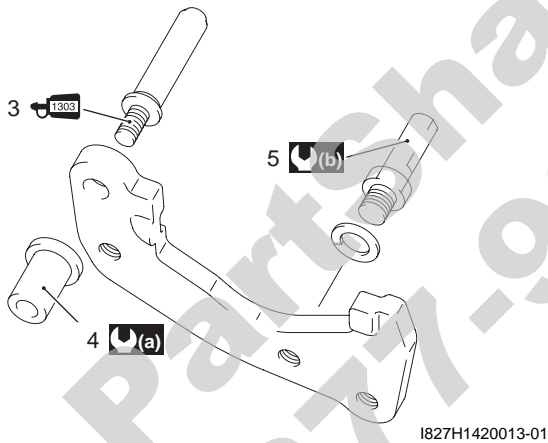

I827H1420013-01

- Set the rubber boots to the caliper.
- Apply silicon grease to the two pins.
 - **SH** : Grease 99000-25100 (SUZUKI SILICONE GREASE or equivalent)
- Install the caliper holder (6) to the brake caliper (7).

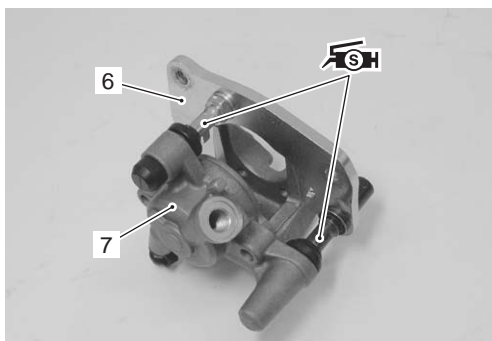

I827H1420014-01

- Install the brake pads. Refer to “Front Brake Pad Replacement (Page 4B-2)”.

Front Brake Caliper Parts Inspection

B827H24206006

Refer to “Front Brake Caliper Disassembly and Assembly (Page 4B-4)”.

Brake Caliper Cylinder

Inspect the brake caliper cylinder wall for nicks, scratches or other damage. If any damage is found, replace the caliper with a new one.

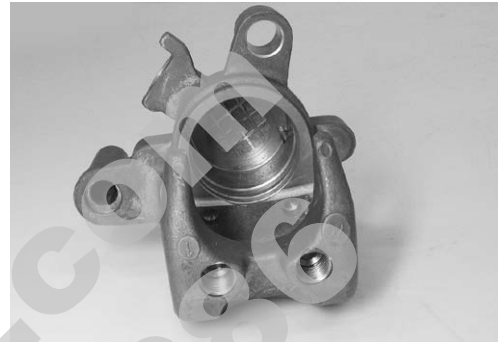

I827H1420015-01

Brake Caliper Piston

Inspect the brake caliper piston surface for any scratches or other damage. If any damage is found, replace the piston with a new one.



I827H1420016-01

Boots

Inspect the boots for damage or wear. If any defects are found, replace them with new ones.



I827H1420017-01

- Apply grease to the anchor pin and brake camshaft sliding surface slightly.

⚠ WARNING

Be careful not to apply too much grease to the brake camshaft and pin. If grease gets on the lining, brake slippage will result.

 Grease 99000-25010 (SUZUKI SUPER GREASE A or equivalent)

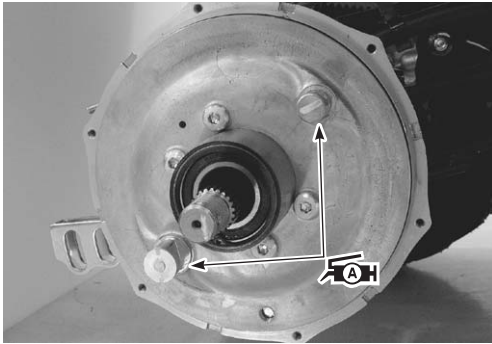

I827H1430020-01

- Install the brake shoes and springs to the brake panel.

NOTE

When reinstalling the removed brake shoes, install them in their original position (leading or trailing).



I827H1430021-01

NOTE

Make sure that brake shoe spring's end faces the brake panel as shown.

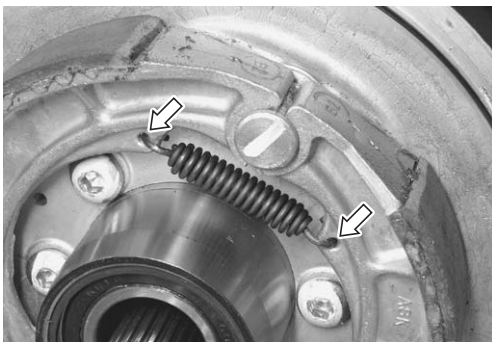

I827H1430022-01

- Install the brake drum (8).
- Install the new O-rings (9) to the brake drum (8).

⚠ CAUTION

Replace the O-rings (9) with new ones.

- Apply grease to the spline on the rear axle.

 Grease 99000-25010 (SUZUKI SUPER GREASE A or equivalent)

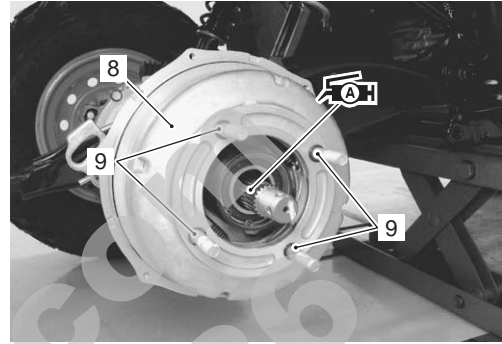

I827H1430023-01

- Install the new dust seal (10) to the drum cover (11) by using the removed dust seal (12).



I827H1430024-01

- Apply grease to the dust seal lips.

 Grease 99000-25100 (SUZUKI SILICONE GREASE or equivalent)

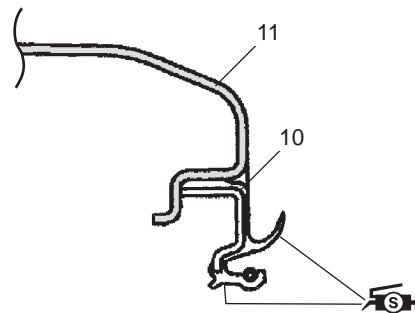

I827H1430026-01

10. Dust seal	11. Drum cover
---------------	----------------

Precautions

Precautions

Precautions for Transmission / Transaxle

Refer to "General Precautions in Section 00 (Page 00-1)".

B827H2500001

PartShark.com
877-999-5686

Movable Drive Face Disassembly and Assembly

B827H25106006

Refer to "Automatic Transmission Components (Page 5A-5)" and "V-belt Type Continuously Variable Automatic Transmission Removal and Installation (Page 5A-7)".

Disassembly

- 1) Remove the spacer (1).

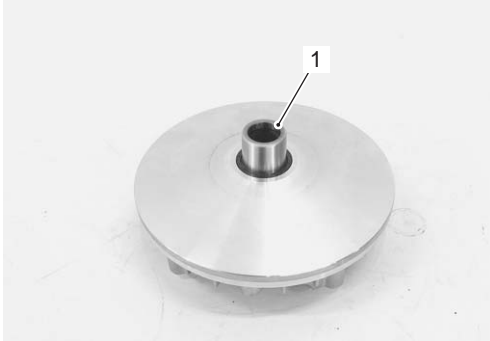

I827H1510021-01

- 2) Remove the dampers (2).
- 3) Remove the rollers (3).

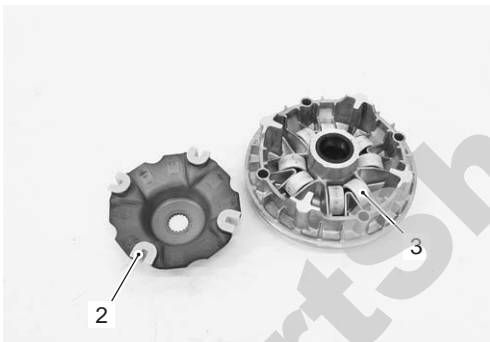

I827H1510022-01

- 4) Remove the oil seals (4) and (5).

NOTE

If there are no abnormal conditions, the oil seal removal is not necessary.

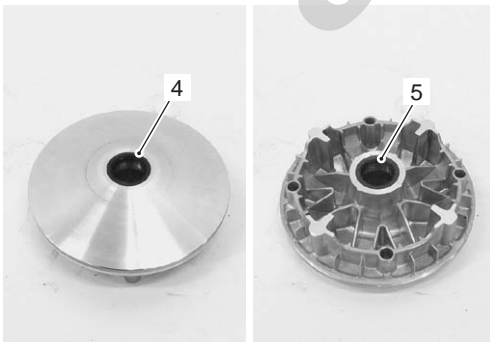

I827H1510023-01

Assembly

- 1) Install the oil seals with the special tool.

Special tool

 (A): 09913-70210 (Bearing installer set)

NOTE

The removed oil seal must be replaced with a new one.

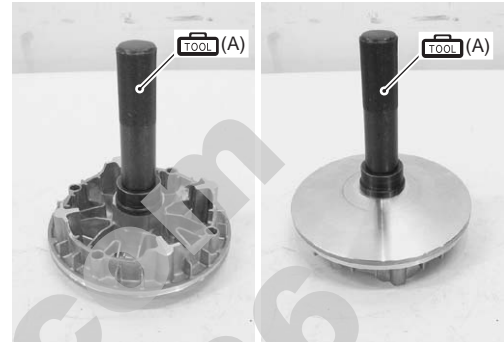

I827H1510024-01

- 2) Apply grease to the lip of oil seals and inside grease groove "A" of the movable drive face.

 : Grease 99000-25010 (SUZUKI SUPER GREASE A or equivalent)

CAUTION

- Wipe off any excess grease thoroughly.
- Take care not to apply grease to the contact surface of the drive V-belt.

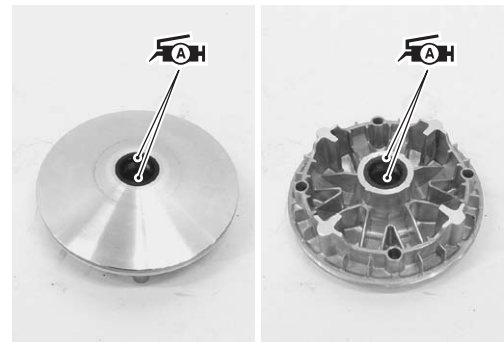

I827H1510025-01

- 3) Assemble the rollers (1) to the movable drive face (2).

3) Remove the retainers (3).

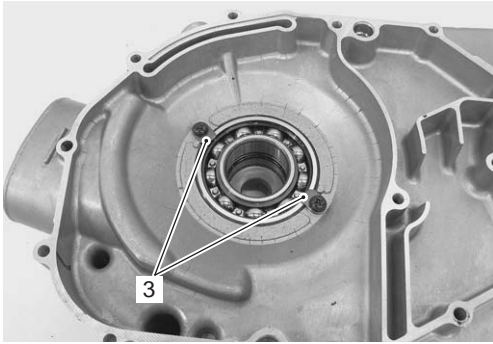

I827H1510069-01

4) Remove the bearing with the special tool.

Special tool

 (A): 09913-70210 (Bearing installer set)

NOTE

If there is no abnormal noise, the bearing removal is not necessary.

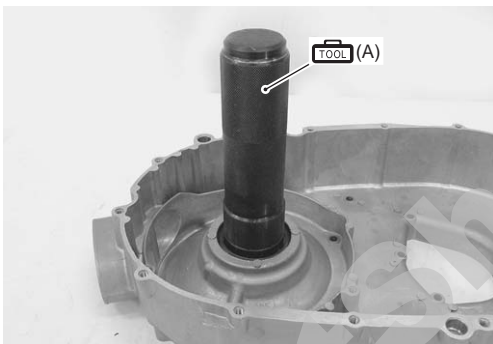

I827H1510070-01

5) Remove the oil seal with the special tool.

Special tool

 (A): 09913-70210 (Bearing installer set)



I827H1510071-01

Assembly

Assembly is in the reverse order of disassembly. Pay attention to the following points:

- Install the oil seal with the special tool.

CAUTION

- The removed oil seal must be replaced with a new one.
- The marked side of the oil seal must face the fixed drive face side.

Special tool

 (A): 09913-70210 (Bearing installer set)

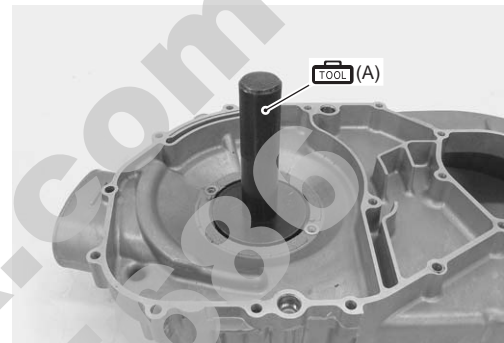

I827H1510072-01

- Install the bearing with the special tool.

Special tool

 (A): 09913-70210 (Bearing installer set)

CAUTION

- The removed bearing must be replaced with a new one.
- The sealed side of the bearing must face the oil seal side.

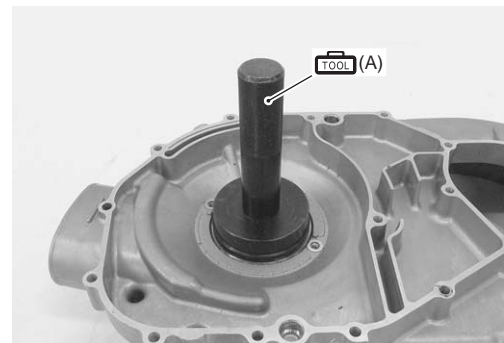

I827H1510073-01

- Fit the special tool and install the 2nd drive gear using a hydraulic press.

Special tool

 (A): 09913-70210 (Bearing installer set)

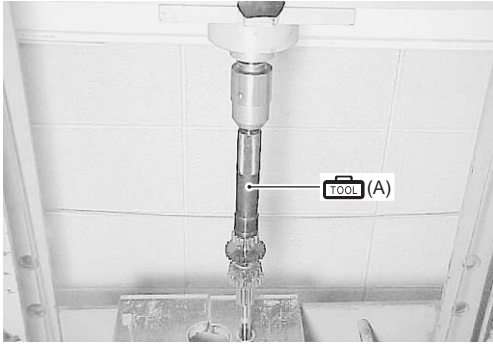

I827H1520013-01

- When installing the bushings, align the shaft hole with the bushing hole.

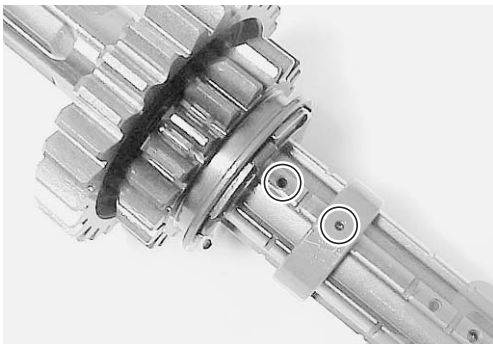

I827H1520014-01

Transmission Reverse Gearshift Cam Disassembly and Assembly (LT-F400/F)

B827H25206005

Refer to "Transmission Removal and Installation (LT-F400/F) (Page 5B-3)".

Disassembly

Disassemble the reverse gearshift cam assembly as shown in the figure.



I827H1520011-03

Assembly

When assembling the reverse gearshift cam, pay attention to the following points:

CAUTION

- Never reuse a snap ring. After a snap ring has been removed from a shaft, it should be discarded and a new snap ring must be installed.
 - When installing a snap ring, care must be taken not to expand the end gap larger than required to slip the snap ring over the shaft.
 - After installing a snap ring, always ensure that it is completely seated in its groove and securely fitted.
-
- Align the punch mark "A" with "B" on the shaft.



I827H1520016-03

Repair Instructions

Clutch Components (LT-F400/F)

B827H25306001

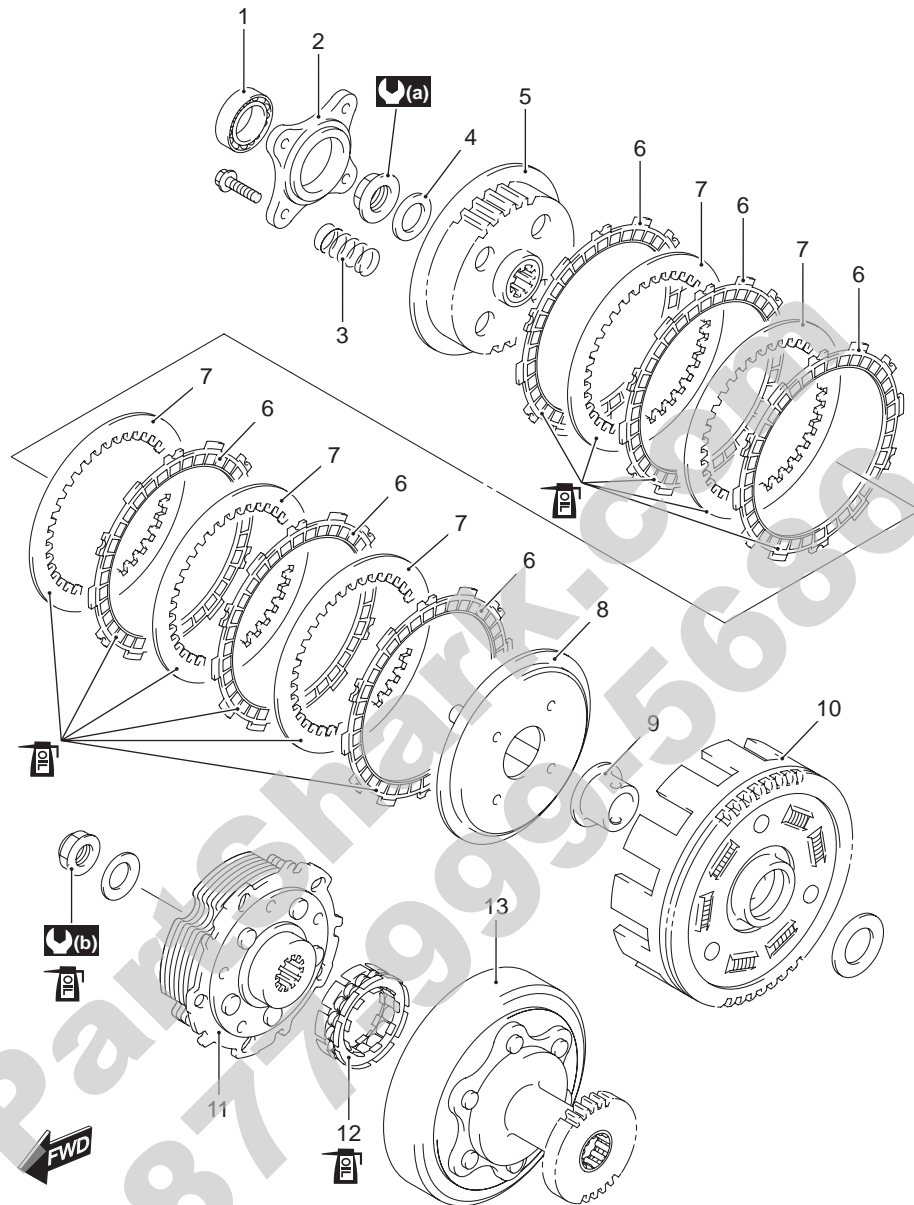

I827H1530001-01

1. Bearing	7. Clutch driven plate	13. Clutch wheel
2. Clutch release plate	8. Clutch pressure plate	(a) : 100 N·m (10.0 kgf-m, 72.5 lb-ft)
3. Clutch spring	9. Collar	(b) : 145 N·m (14.5 kgf-m, 105.0 lb-ft)
4. Washer	10. Primary driven gear assembly	(a) : Apply engine oil.
5. Clutch sleeve hub	11. Clutch shoe assembly	
6. Clutch drive plate	12. One-way clutch	

Section 6

Steering

CONTENTS

Precautions	6-1	Handlebars Removal and Installation	6B-3
Precautions	6-1	Handlebars Inspection	6B-5
Precautions for Steering	6-1	Steering Shaft / Tie-rod Removal and Installation	6B-5
Steering General Diagnosis	6A-1	Steering Parts Inspection	6B-10
Diagnostic Information and Procedures	6A-1	Specifications	6B-11
Steering Symptom Diagnosis.....	6A-1	Service Data (LT-A400/F, LT-F400/F)	6B-11
Steering / Handlebar	6B-1	Tightening Torque Specifications.....	6B-11
Repair Instructions	6B-1	Special Tools and Equipment	6B-12
Steering / Handlebars Components	6B-1	Recommended Service Material	6B-12
Steering Assembly Construction	6B-2	Special Tool	6B-12

- Apply grease to the steering shaft bushing (1).

 **Grease 99000-25010 (SUZUKI SUPER GREASE A or equivalent)**

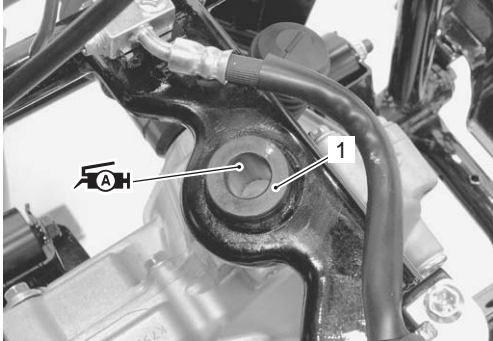

I827H1620030-02

- Apply grease to the steering shaft and dust seal (2).

 **Grease 99000-25010 (SUZUKI SUPER GREASE A or equivalent)**

- Install the dust seal (2) to the steering shaft.



I827H1620031-02

- Install the steering shaft.
- Apply grease to the O-ring (3) and dust seal (4).

CAUTION

Replace the O-ring (3) with a new one.

 **Grease 99000-25010 (SUZUKI SUPER GREASE A or equivalent)**

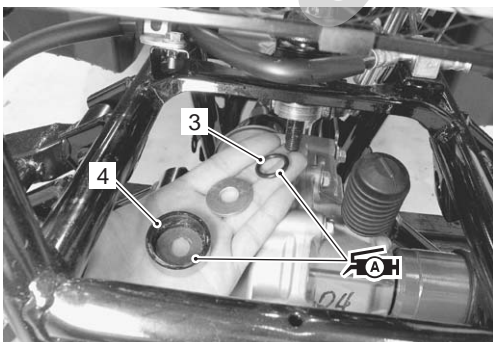

I827H1620032-02

- Apply grease to the dust seals before installing the steering shaft.

 **Grease 99000-25010 (SUZUKI SUPER GREASE A or equivalent)**



I827H1620033-02

- Apply grease to the steering shaft holders before installing the shaft holders.

 **Grease 99000-25010 (SUZUKI SUPER GREASE A or equivalent)**

CAUTION

To prevent the entry of dirt, the dust seal end "A" must face rearward when installing the dust seals to steering shaft.

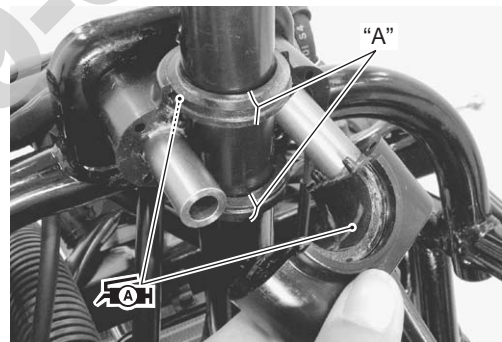

I827H1620034-03

- Tighten the steering shaft holder bolts to the specified torque.

Tightening torque

Steering shaft holder bolt (a): 23 N·m (2.3 kgf·m, 16.5 lb-ft)



I827H1620035-01

LT-A400F (P-17)

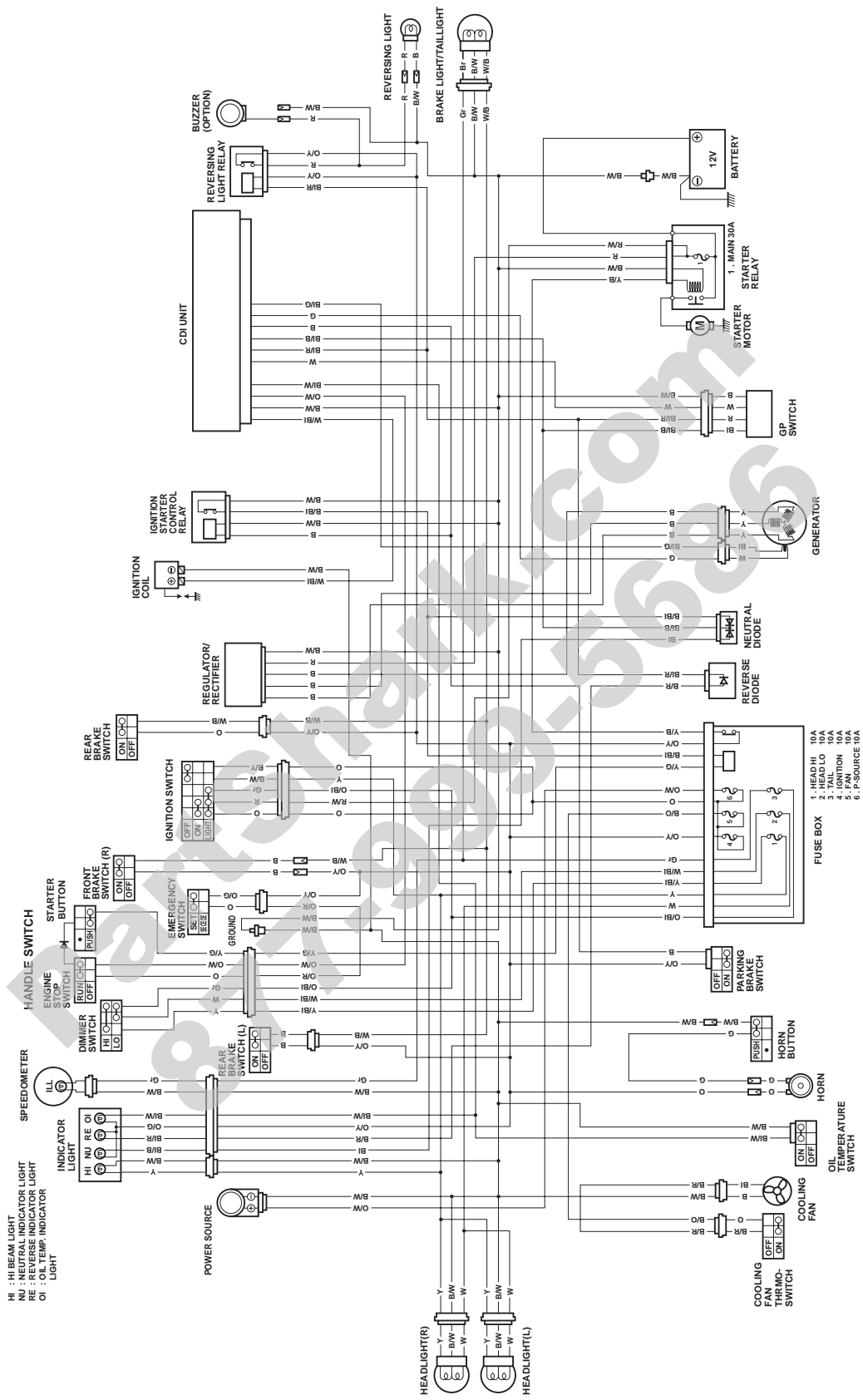

HI : HI BEAM LIGHT
NU : NEUTRAL INDICATOR LIGHT
RE : REVERSE INDICATOR LIGHT
OI : OIL TEMP. INDICATOR LIGHT

- 1. HEAD HI 10A
- 2. HEAD LO 10A
- 3. IGNITION 10A
- 4. FAN 10A
- 5. FAN 10A
- 6. P-SOURCE 10A

Headlight Components

B827H29206003

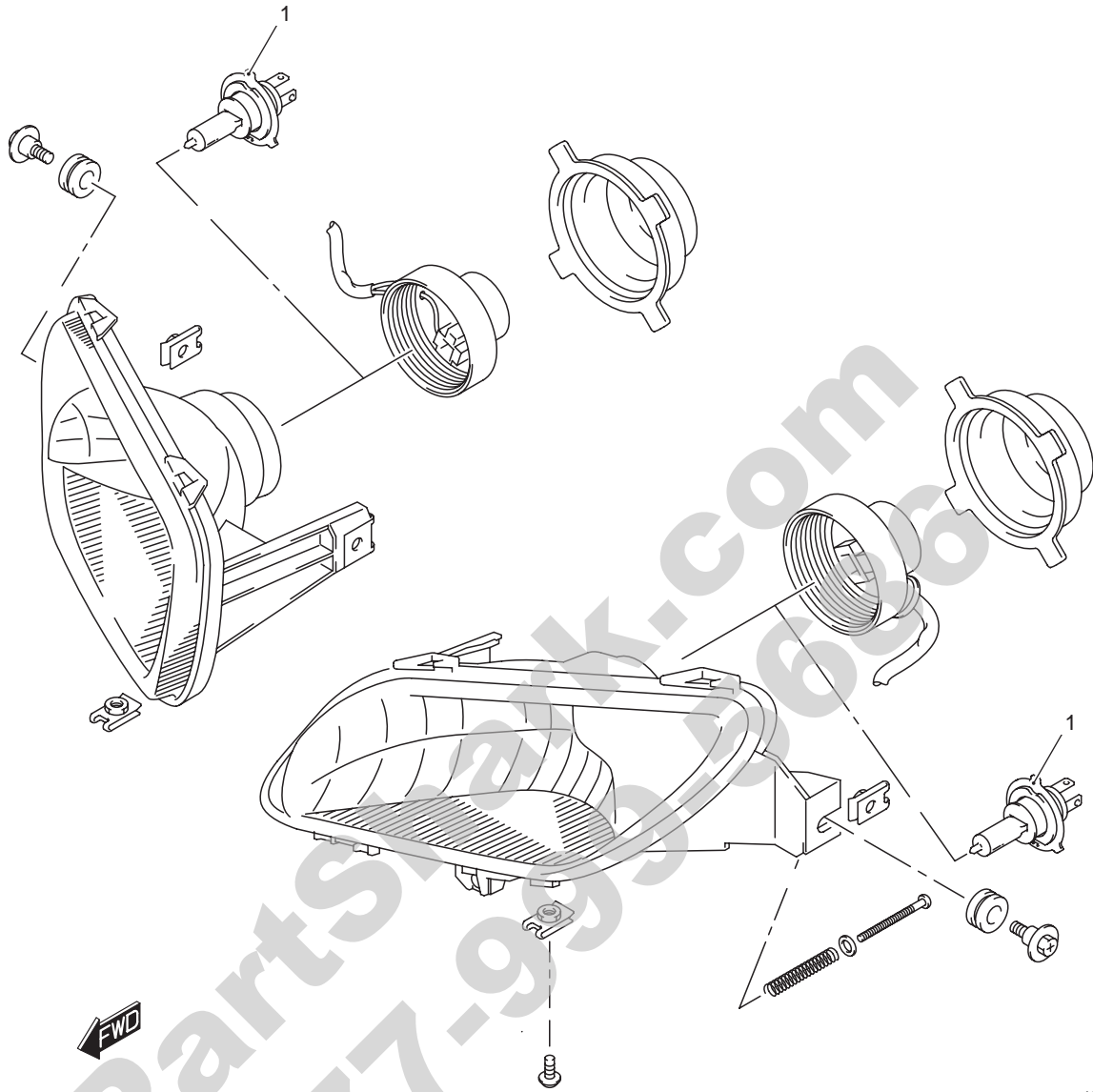

1. Headlight bulb (12 V 35/35 W x2)

I827H1920004-01

Headlight Removal and Installation

B827H29206004

Removal

1) Disconnect the headlight coupler (1).

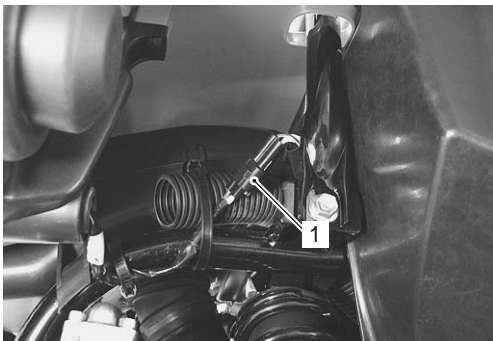

I827H1920005-01

2) Remove the headlight with the housing (2).

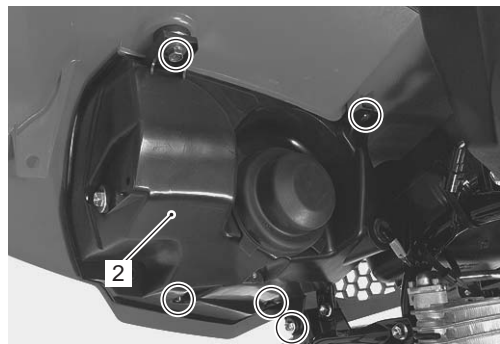

I827H1920006-03

Fastener Removal and Installation

B827H29406002

Type A Removal

- 1) Depress the head of fastener center piece (1).
- 2) Pull out the fastener (2).

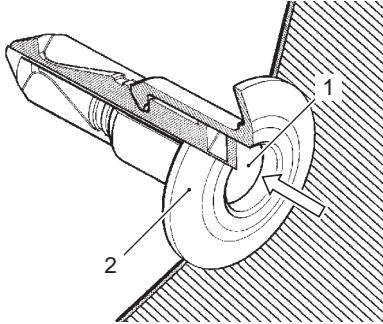

I649G1940005-02

Installation

- 1) Let the center piece stick out toward the head so that the pawls "A" closes.

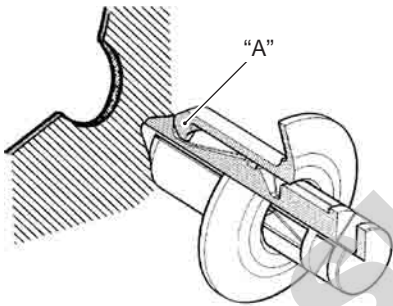

I649G1940006-02

- 2) Insert the fastener into the installation hole.

NOTE

To prevent the pawl "A" from damage, insert the fastener all the way into the installation hole.

- 3) Push in the head of center piece until it becomes flush with the fastener outside face.

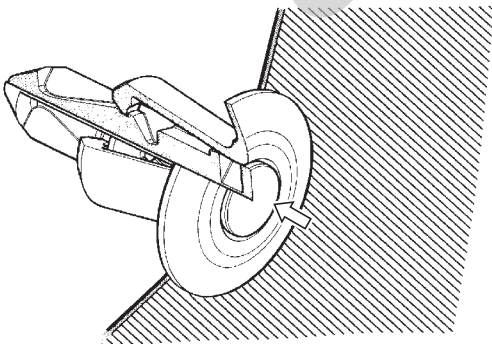

I649G1940007-02

Type B Removal

- 1) Pry up the head of fastener center piece (1) with a screw driver.
- 2) Pull out the fastener "A".

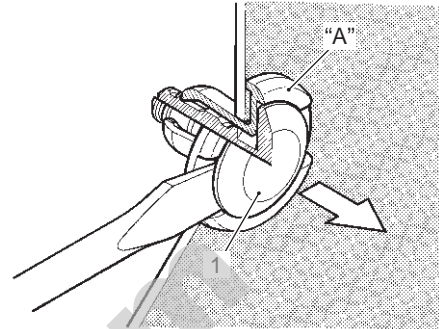

I823H1940001-01

Installation

- 1) Insert the fastener into the installation hole.

NOTE

To prevent the pawl (2) from damage, insert the fastener all the way into the installation hole.

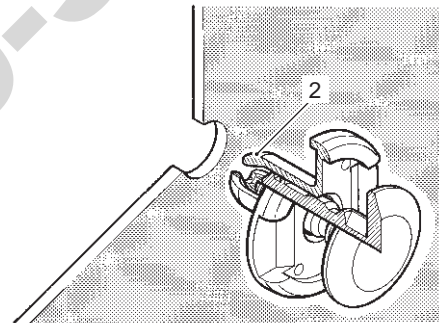

I823H1940002-01

- 2) Push in the head of center piece.

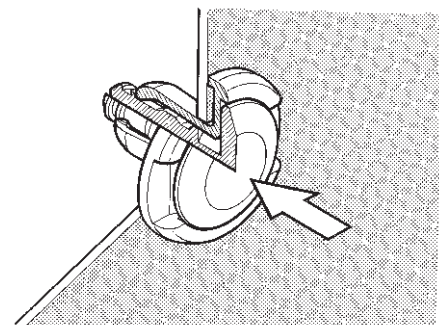

I823H1940003-01

Installation

Install the front grip bar in the reverse order of removal. Pay attention to the following point:

- Tighten the front grip bar mounting bolts to the specified torque.

Tightening torque

Front grip bar mounting bolt (a): 28 N-m (2.8 kgf-m, 20.0 lb-ft)

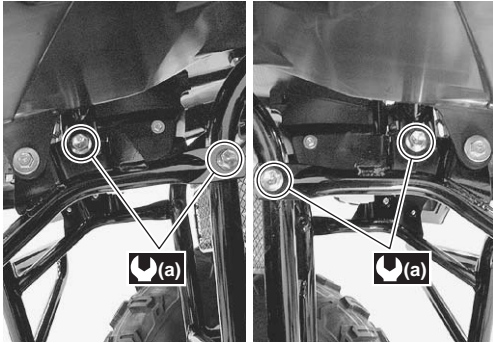

I827H1950015-02



I827H1950016-02

Trailer Towing Removal and Instruction

B827H29506009

Removal

Remove the trailer towing (1) by removing the bolts.

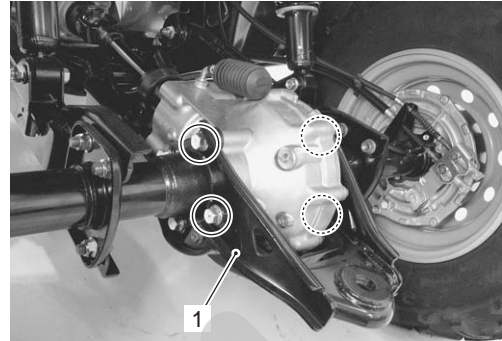

I827H1950017-01

Installation

Apply thread lock to the rear axle housing mounting bolts and tighten them to the specified torque.

1303 : Thread lock cement 99000-32030 (THREAD LOCK CEMENT SUPER 1303 or equivalent)

Tightening torque

Rear axle housing mounting bolt (final gear case) (a): 55 N-m (5.5 kgf-m, 40.0 lb-ft)

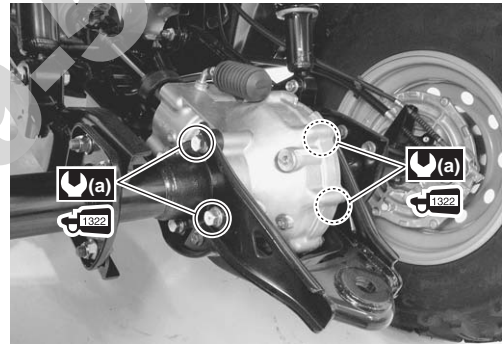

I827H1950018-01

Parts Catalog 877-990-8888

CLICK HERE TO **DOWNLOAD** THE COMPLETE MANUAL

- Thank you very much for reading the preview of the manual.
- You can download the complete manual from: www.heydownloads.com by clicking the link below



- Please note: If there is no response to CLICKING the link, please download this PDF first and then click on it.

CLICK HERE TO **DOWNLOAD** THE COMPLETE MANUAL