

# IMPORTANT

## WARNING/CAUTION/NOTE

Please read this manual and follow its instructions carefully. To emphasize special information, the words

**⚠ WARNING**, **⚠ CAUTION** and **NOTE** have special meanings. Pay special attention to the messages highlighted by these signal words.

### **⚠ WARNING**

---

Indicates a potential hazard that could result in death or injury.

---

### **⚠ CAUTION**

---

Indicates a potential hazard that could result in vehicle damage.

---

### **NOTE:**

---

Indicates special information to make maintenance easier or instructions clearer.

---

### **⚠ WARNING**

---

This service manual is intended for authorized Suzuki dealers and qualified service technicians only. Inexperienced technicians or technicians without the proper tools and equipment may not be able to properly perform the services described in this manual.

Improper repair may result in injury to the technician and may render the vehicle unsafe for the driver and passengers.

---

### **⚠ WARNING**

---

For vehicles equipped with a Supplemental Restraint (Air Bag) System:

- Service on and around the air bag system components or wiring must be performed only by an authorized SUZUKI dealer. Refer to “Air Bag System Components and Wiring Location View” under “General Description” in air bag system section in order to confirm whether you are performing service on or near the air bag system components or wiring. Please observe all WARNINGS and “Service Precautions” under “On-Vehicle Service” in air bag system section before performing service on or around the air bag system components or wiring. Failure to follow WARNINGS could result in unintentional activation of the system or could render the system inoperative. Either of these two conditions may result in severe injury.
  - If the air bag system and another vehicle system both need repair, Suzuki recommends that the air bag system be repaired first, to help avoid unintended air bag system activation.
  - Do not modify the steering wheel, instrument panel or any other air bag system component on or around air bag system components or wiring. Modifications can adversely affect air bag system performance and lead to injury.
  - If the vehicle will be exposed to temperatures over 93 °C (200 °F), for example, during a paint baking process, remove the air bag system components, that is air bag (inflator) modules, SDM and/or seat belt with pretensioner, beforehand to avoid component damage or unintended activation.
- 

The circle with a slash in this manual means “Don’t do this” or “Don’t let this happen”.

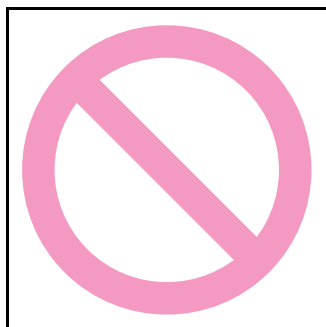

CLICK HERE TO **DOWNLOAD** THE COMPLETE MANUAL

- Thank you very much for reading the preview of the manual.
- You can download the complete manual from: [www.heydownloads.com](http://www.heydownloads.com) by clicking the link below



- Please note: If there is no response to CLICKING the link, please download this PDF first and then click on it.

CLICK HERE TO **DOWNLOAD** THE COMPLETE MANUAL

## Precautions for Installing Mobile Communication Equipment

S5JB0A000004

When installing mobile communication equipment such as CB (Citizens-Band)-radio or cellular-telephone, be sure to observe the following precautions. Failure to follow cautions may adversely affect electronic control system.

- Keep the antenna as far away as possible from the vehicle's electronic control unit.
- Keep the antenna feeder more than 20 cm (7.9 in.) away from electronic control unit and its wire harnesses.
- Do not run the antenna feeder parallel with other wire harnesses.
- Confirm that the antenna and feeder are correctly adjusted.

## Air Bag Warning

S5JB0A000007

### **▲ WARNING**

For vehicles equipped with Supplemental Restraint (Air Bag) System:

- Service on and around the air bag system components or wiring must be performed only by an authorized SUZUKI dealer. Refer to "Air Bag System Components, Wiring and Connectors Location: in Section 8B" in order to confirm whether you are performing service on or near the air bag system components or wiring. Please observe all "WARNING"s and "Precautions on Service and Diagnosis of Air Bag System: in Section 8B" before performing service on or around the air bag system components or wiring. Failure to follow "WARNING"s could result in unintentional activation of the system or could render the system inoperative. Either of these two conditions may result in severe injury.
- Technical service work must be started at least 90 seconds after the ignition switch is turned to the "LOCK" position and the negative cable is disconnected from the battery. Otherwise, the system may be activated by reserve energy in the Sensing and Diagnostic Module (SDM).

## Discharge Headlight Warning

S5JB0A0000014

### **▲ WARNING**

When performing service on and around the discharge headlight, observe "Precautions for Discharge Headlight Service (If Equipped): in Section 9B". Neglecting the warnings may result in personal injury.

## A/C System Caution

S5JB0A0000015

### **▲ CAUTION**

The air conditioning system of this vehicle uses refrigerant HFC-134a (R-134a). None of refrigerant, compressor oil and component parts is interchangeable between two types of A/C: one using refrigerant CFC-12 (R-12) and the other using refrigerant HFC-134a (R-134a).

Be sure to check which refrigerant is used before any service work including inspection and maintenance. For identification between these two types, refer to "A/C Refrigerant Type Description: in Section 7B".

When replenishing or changing refrigerant and compressor oil and when replacing parts, make sure that the material or the part to be used is appropriate to the A/C installed in the vehicle being serviced.

Use of incorrect one will result in leakage of refrigerant, damage in parts or other faulty condition.

## Fastener Caution

S5JB0A0000009

### **▲ CAUTION**

When fasteners are removed, always reinstall them at the same location from which they were removed. If a fastener needs to be replaced, use the correct part number fastener for that application. If the correct part number fastener is not available, a fastener of equal size and strength (or stronger) may be used. Fasteners that are not reused, and those requiring thread-locking compound, will be called out. The correct torque value must be used when installing fasteners that require it. If the above procedures are not followed, parts or system damage could result.

Severe Condition Code	Maintenance		Maintenance Operation	Maintenance Interval
A B C – E F – H	Spark plugs	Nickel plug	☞ R	Every 10,000 km (6,000 miles) or 8 months
		Iridium plug (Highly recommended)		Every 30,000 km (18,000 miles) or 24 months
– B C D – – – H	Wheel bearings		☞ I	Every 15,000 km (9,000 miles) or 12 months
– B – D E – – H	Drive shaft boots and propeller shafts		☞ I	Every 15,000 km (9,000 miles) or 12 months
– B – – E – – H	Manual transmission oil / Transfer oil / Differential oil		☞ / ☞ R	First time only: 15,000 km (9,000 miles) or 12 months
				Second time and after: Every 30,000 km (18,000 miles) or 24 months reckoning from 0 km (0 mile) or 0 month
– B – – E – – H	Automatic transmission fluid		☞ R	Every 30,000 km (18,000 miles) or 24 months
– – C D – – – –	HVAC air filter (if equipped) *2		☞ I	Every 15,000 km (9,000 miles) or 12 months
			☞ R	Every 45,000 km (27,000 miles) or 36 months

**NOTE**

- 
- “I”: Inspect and correct or replace if necessary.
  - “R”: Replace or change.
  - “T”: Tighten to specified torque.
  - \*1: Inspect more frequently if the vehicle is used under dusty conditions.
  - \*2: Clean more frequently if the air flow from air conditioning decreases.
-

Valves and Valve Guides Inspection.....	1D-38	Timing Chain Cover Cleaning and Inspection.....	1D-87
Cylinder Head Inspection.....	1D-40	2nd Timing Chain and Chain Tensioner Components.....	1D-87
Valve Spring Inspection.....	1D-41	2nd Timing Chain and Chain Tensioner Removal and Installation.....	1D-88
Pistons, Piston Rings, Connecting Rods and Cylinders Components.....	1D-42	2nd Timing Chain and Chain Tensioner Inspection.....	1D-90
Pistons, Piston Rings, Connecting Rods and Cylinders Removal and Installation.....	1D-42	1st Timing Chain and Chain Tensioner Components.....	1D-91
Pistons, Piston Rings, Connecting Rods and Cylinders Disassembly and Assembly.....	1D-44	1st Timing Chain and Chain Tensioner Removal and Installation.....	1D-92
Cylinders, Pistons and Piston Rings Inspection.....	1D-45	1st Timing Chain and Chain Tensioner Inspection.....	1D-94
Piston Pins and Connecting Rods Inspection.....	1D-47	Camshafts, Tappet and Shim Components.....	1D-95
Crank Pin and Connecting Rod Bearings Inspection.....	1D-48	Camshafts, Tappet and Shim Removal and Installation.....	1D-95
Main Bearings, Crankshaft and Cylinder Block Components.....	1D-52	Camshaft, Tappet and Shim Inspection.....	1D-97
Main Bearings, Crankshaft and Cylinder Block Removal and Installation.....	1D-53	Valves and Cylinder Head Components.....	1D-99
Crankshaft Inspection.....	1D-56	Valves and Cylinder Head Removal and Installation.....	1D-99
Main Bearings Inspection.....	1D-57	Valves and Cylinder Head Disassembly and Assembly.....	1D-101
Sensor Plate Inspection.....	1D-61	Valves and Valve Guides Inspection.....	1D-104
Rear Oil Seal Inspection.....	1D-61	Cylinder Head Inspection.....	1D-106
Flywheel Inspection.....	1D-62	Valve Spring Inspection.....	1D-107
Cylinder Block Inspection.....	1D-62	Pistons, Piston Rings, Connecting Rods and Cylinders Components.....	1D-108
<b>Specifications.....</b>	<b>1D-63</b>	Pistons, Piston Rings, Connecting Rods and Cylinders Removal and Installation.....	1D-108
Tightening Torque Specifications.....	1D-63	Pistons, Piston Rings, Connecting Rods and Cylinders Disassembly and Assembly...	1D-109
<b>Special Tools and Equipment.....</b>	<b>1D-64</b>	Pistons, Piston Rings, Connecting Rods and Cylinders Inspection and Cleaning.....	1D-112
Recommended Service Material.....	1D-64	Main Bearings, Crankshaft and Cylinder Block Components.....	1D-118
Special Tool.....	1D-64	Main Bearings, Crankshaft and Cylinder Block Removal and Installation.....	1D-119
<b>For J20 Engine.....</b>	<b>1D-66</b>	Main Bearings, Crankshaft and Cylinder Block Inspection.....	1D-122
<b>General Description.....</b>	<b>1D-66</b>	<b>Specifications.....</b>	<b>1D-129</b>
Engine Construction Description.....	1D-66	Tightening Torque Specifications.....	1D-129
Air Cleaner Element Introduction.....	1D-68	<b>Special Tools and Equipment.....</b>	<b>1D-130</b>
IMT (Intake Manifold Tuning) System.....	1D-68	Recommended Service Material.....	1D-130
<b>Diagnostic Information and Procedures.....</b>	<b>1D-70</b>	Special Tool.....	1D-130
Compression Check.....	1D-70	<b>Engine Lubrication System.....</b>	<b>1E-1</b>
Engine Vacuum Check.....	1D-71	<b>For M16A Engine with VVT.....</b>	<b>1E-1</b>
Valve Lash (Clearance) Inspection.....	1D-72	<b>General Description.....</b>	<b>1E-1</b>
<b>Repair Instructions.....</b>	<b>1D-75</b>	Engine Lubrication Description.....	1E-1
Air Cleaner Assembly Removal and Installation.....	1D-75	<b>Diagnostic Information and Procedures.....</b>	<b>1E-3</b>
Air Cleaner Filter Removal and Installation.....	1D-75	Oil Pressure Check.....	1E-3
Air Cleaner Filter Inspection and Cleaning.....	1D-75	<b>Repair Instructions.....</b>	<b>1E-4</b>
Throttle Body and Intake Manifold Components.....	1D-76	Oil Pan and Oil Pump Strainer Components.....	1E-4
Throttle Body On-Vehicle Inspection.....	1D-76	Oil Pan and Oil Pump Strainer Removal and Installation.....	1E-5
Electric Throttle Body Assembly Removal and Installation.....	1D-76	Oil Pan and Oil Pump Strainer Cleaning.....	1E-6
Throttle Body Cleaning.....	1D-77	Oil Pump Components.....	1E-7
Intake Manifold Removal and Installation.....	1D-77	Oil Pump Removal and Installation.....	1E-7
Cylinder Head Cover Removal and Installation.....	1D-78		
Engine Mountings Components.....	1D-80		
Engine Assembly Removal and Installation.....	1D-81		
Timing Chain Cover Components.....	1D-84		
Timing Chain Cover Removal and Installation.....	1D-84		



**1A-31 Engine General Information and Diagnosis:**

DTC No.	Detecting item	Detecting condition (DTC will set when detecting:)	MIL
☞ *P0102	Mass air flow circuit low input	Output voltage of MAF sensor is less than specification.	1 driving cycle
☞ *P0103	Mass air flow circuit high input	Output voltage of MAF sensor is more than specification.	1 driving cycle
☞ △*P0106	Manifold absolute pressure circuit range/performance	Difference between Max. manifold absolute pressure value and Min. manifold pressure value is less than specification or difference between barometric pressure value and manifold pressure value is less than specification	2 driving cycles
☞ *P0107	Manifold absolute pressure circuit low input	Output voltage of MAP sensor is less than specification.	1 driving cycle
☞ *P0108	Manifold absolute pressure circuit high input	Output voltage of MAP sensor is more than specification.	1 driving cycle
☞ △*P0111	Intake air temperature sensor circuit range/performance	Variation of intake air temperature from engine start is less than specification.	2 driving cycles
☞ *P0112	Intake air temperature sensor circuit low	Circuit voltage of IAT sensor is less than specification.	1 driving cycle
☞ *P0113	Intake air temperature sensor circuit high	Circuit voltage of IAT sensor is more than specification.	1 driving cycle
☞ △*P0116	Engine coolant temperature circuit range/performance	Engine coolant temperature is less than specified temperature for specified time from engine start.	2 driving cycles
☞ *P0117	Engine coolant temperature circuit low	Circuit voltage of ECT sensor is less than specification.	1 driving cycle
☞ *P0118	Engine coolant temperature circuit high	Circuit voltage of ECT sensor is more than specification.	1 driving cycle
☞ *P0122	Throttle position sensor (main) circuit low	Output voltage of throttle position sensor (main) is lower than specification.	1 driving cycle
☞ *P0123	Throttle position sensor (main) circuit high	Output voltage of throttle position sensor (main) is higher than specification.	1 driving cycle
☞ △*P0131	O2 sensor (HO2S) circuit low voltage (Sensor-1)	Output voltage or sensor current of A/F sensor is less than specification.	2 driving cycles
☞ △*P0132	O2 sensor (HO2S) circuit high voltage (Sensor-1)	Output voltage or sensor current of A/F sensor is more than specification.	2 driving cycles
☞ △*P0133	O2 sensor (HO2S) circuit slow response (Sensor-1)	Ratio between integrated value of A/F sensor output variation and integrated value of short term fuel trim variation is more than specification.	2 driving cycles
☞ △*P0134	O2 sensor (HO2S) circuit no activity detected (Sensor-1)	Impedance of A/F sensor element is higher than specification for more than 160 sec. even though A/F sensor heater is turned ON for more than specified time.	2 driving cycles
☞ △*P0137	O2 sensor (HO2S) circuit low voltage (Sensor-2)	HO2S-2 voltage is lower than 0.4 V for more than specified time continuously while vehicle is driving with high engine load (high speed). And HO2S-2 max. voltage minus HO2S-2 min. voltage is less than 0.2 V for specified time continuously.	2 driving cycles
☞ △*P0138	O2 sensor (HO2S) circuit high voltage (Sensor-2)	HO2S-2 voltage is higher than 0.85 V for more than specified time continuously while vehicle is driving with high engine load (high speed). And HO2S-2 max. voltage minus HO2S-2 min. voltage is less than 0.2 V for specified time continuously.	2 driving cycles
☞ △*P0140	O2 sensor (HO2S) circuit no activity detected (Sensor-2)	Output voltage of HO2S-2 is more than specification after warming up engine.	2 driving cycles
☞ △*P0171	System too lean	Total fuel trim is larger than specification for specified time or longer. (Fuel trim toward rich side is large.)	2 driving cycles
☞ △*P0172	System too rich	Total fuel trim is smaller than specification for specified time or longer. (Fuel trim toward lean side is large.)	2 driving cycles
☞ *P0222	Throttle position sensor (sub) circuit low	Output voltage of throttle position sensor (sub) is lower than specification.	1 driving cycle

**Engine Symptom Diagnosis**

Perform troubleshooting referring to the followings when ECM has detected no DTC and no abnormality has been found in “Visual Inspection: ” and “Engine Basic Inspection: ”.

<b>Condition</b>	<b>Possible cause</b>	<b>Correction / Reference Item</b>
<b>Hard starting (Engine cranks OK)</b>	Faulty spark plug	“Spark Plug Inspection: in Section 1H”
	Leaky high-tension cord (for M16 engine)	“High-Tension Cord Inspection (For M16 Engine): in Section 1H”
	Loose connection or disconnection of high-tension cord(s) or lead wire(s) (for M16 engine)	“High-Tension Cord Removal and Installation (For M16 Engine): in Section 1H”
	Faulty ignition coil	“Ignition Coil Assembly (Including ignitor) Inspection: in Section 1H”
	Dirty or clogged fuel hose or pipe	“Fuel Pressure Check: ”
	Malfunctioning fuel pump	“Fuel Pressure Check: ”
	Air drawn in through intake manifold gasket or throttle body gasket	
	Faulty electric throttle body assembly	“Electric Throttle Body Assembly On-Vehicle Inspection: in Section 1C”
	Faulty accelerator pedal position (APP) sensor assembly	“Accelerator Pedal Position (APP) Sensor Assembly Inspection: in Section 1C”
	Faulty ECT sensor or MAF sensor	“Engine Coolant Temperature (ECT) Sensor Inspection: in Section 1C” or “Mass Air Flow (MAF) and Intake Air Temperature (IAT) Sensor Inspection: in Section 1C”
	Faulty ECM	
	Low compression	“Compression Check: For M16A Engine with VVT in Section 1D” or “Compression Check: For J20 Engine in Section 1D”
	Poor spark plug tightening or faulty gasket	“Spark Plug Removal and Installation: in Section 1H”
	Compression leak from valve seat	“Valves and Valve Guides Inspection: For J20 Engine in Section 1D” or “Valves and Valve Guides Inspection: For M16A Engine with VVT in Section 1D”.
	Sticky valve stem	“Valves and Valve Guides Inspection: For J20 Engine in Section 1D” or “Valves and Valve Guides Inspection: For M16A Engine with VVT in Section 1D”.
	Weak or damaged valve springs	“Valve Spring Inspection: For J20 Engine in Section 1D” or “Valve Spring Inspection: For M16A Engine with VVT in Section 1D”
	Compression leak at cylinder head gasket	“Cylinder Head Inspection: For J20 Engine in Section 1D” or “Cylinder Head Inspection: For M16A Engine with VVT in Section 1D”
	Sticking or damaged piston ring	“Pistons, Piston Rings, Connecting Rods and Cylinders Inspection and Cleaning: For J20 Engine in Section 1D” or “Cylinders, Pistons and Piston Rings Inspection: For M16A Engine with VVT in Section 1D”
	Worn piston, ring or cylinder	“Pistons, Piston Rings, Connecting Rods and Cylinders Inspection and Cleaning: For J20 Engine in Section 1D” or “Cylinders, Pistons and Piston Rings Inspection: For M16A Engine with VVT in Section 1D”
	Malfunctioning PCV valve	“PCV Valve Inspection: in Section 1B”
Camshaft position control (VVT) system out of order (for M16 engine)	“Oil Control Valve Inspection: For M16A Engine with VVT in Section 1D”	
Faulty EGR system	“EGR System Inspection: in Section 1B”	

DTC Troubleshooting

NOTE

Before this trouble shooting is performed, read the precautions for DTC troubleshooting referring to "Precautions For DTC Troubleshooting: ".

Step	Action	Yes	No
1	Was "Engine and Emission Control System Check" performed?	Go to Step 2.	Go to "Engine and Emission Control System Check: ".
2	<b>DTC check</b> Is there any DTC(s) other than P0030?	Go to applicable DTC diag. flow.	Go to Step 3.
3	<b>Sensor circuit check</b> 1) Disconnect connectors from A/F sensor and ECM with ignition switch turned OFF. 2) Check for proper connection to A/F sensor terminals and ECM terminals. 3) If wire and connection are OK, measure each wire resistance of A/F sensor circuit (sensor and heater) between A/F sensor connector and ECM connector. Is each measured wire resistance lower than 1 Ω?	Go to Step 4.	Repair or replace defective wire circuit.
4	<b>Sensor circuit insulation check</b> 1) Measure resistance between wire and wire at sensor circuit terminals of A/F sensor connector (no continuity check). Is measured resistance infinity?	Substitute a known good A/F sensor and recheck.	Repair or replace defective circuit.

DTC P0031 / P0032: HO2S Heater Control Circuit Low / High (Sensor-1)

S5JB0A1104015

Wiring Diagram

Refer to "DTC P0030: HO2S Heater Control Circuit (Sensor-1): ".

A/F Sensor Description

Refer to "A/F Sensor Description: ".

DTC Detecting Condition and Trouble Area

DTC detecting condition	Trouble area
<p><b>P0031:</b> Heater control circuit voltage of A/F sensor is lower than specification for more than specified time continuously even though control duty ratio of A/F sensor heater is less than 90% with engine running. (Heater control duty pulse is not detected in its circuit of ECM) (2 driving cycle detection logic)</p> <p><b>P0032:</b> Heater control circuit voltage of A/F sensor is higher than specification for more than specified time continuously even though control duty ratio of A/F sensor heater is more than 10% with engine running. (Heater control duty pulse is not detected in its circuit of ECM) (2 driving cycle detection logic)</p>	<ul style="list-style-type: none"> <li>• A/F sensor heater circuit</li> <li>• A/F sensor heater</li> <li>• ECM</li> </ul>

Step	Action	Yes	No
6	<b>MAP sensor signal circuit check</b> 1) Disconnect connectors from ECM with ignition switch turned OFF. 2) Measure resistance between "C37-55" terminal of ECM connector and vehicle body ground.  <i>Is resistance infinity?</i>	Go to Step 7.	"RED/WHT" wire is shorted to ground circuit.
7	<b>MAP sensor output signal check</b> 1) Check MAP sensor according to "Manifold Absolute Pressure (MAP) Sensor Inspection: in Section 1C".  <i>Is it in good condition?</i>	Substitute a known-good ECM and recheck.	Faulty MAP sensor.

**DTC P0108: Manifold Absolute Pressure Circuit High Input**

S5JB0A1104022

**Wiring Diagram**

Refer to "DTC P0106: Manifold Absolute Pressure Range / Performance: ".

**DTC Detecting Condition and Trouble Area**

DTC detecting condition	Trouble area
Manifold absolute pressure sensor output voltage is higher than specified value for specified time continuously. (1 driving cycle detection logic)	<ul style="list-style-type: none"> <li>• Manifold absolute pressure sensor circuit</li> <li>• Manifold absolute pressure sensor</li> <li>• ECM</li> </ul>

**NOTE**

When DTC P0113, P0118 and P0533 are indicated together, it is possible that "GRY/GRN" wire circuit is open.

**DTC Confirmation Procedure**

- 1) Connect scan tool to DLC with ignition switch turned OFF.
- 2) Turn ON ignition switch and clear DTC using scan tool and warm up engine completely.
- 3) Run engine at idle speed for 1 min.
- 4) Check DTC and pending DTC.

**DTC Troubleshooting**

**NOTE**

Before this trouble shooting is performed, read the precautions for DTC troubleshooting referring to "Precautions For DTC Troubleshooting: ".

Step	Action	Yes	No
1	Was "Engine and Emission Control System Check" performed?	Go to Step 2.	Go to "Engine and Emission Control System Check: ".
2	<b>MAP sensor and its circuit check</b> 1) Connect scan tool to DLC with ignition switch OFF. 2) Turn ignition switch ON. 3) Check intake manifold pressure displayed on scan tool.  <i>Is it 127 kPa (37.5 in.Hg)?</i>	Go to Step 3.	Intermittent trouble. Check for intermittent referring to "Intermittent and Poor Connection Inspection: in Section 00".

**DTC Confirmation Procedure**

- 1) With ignition switch turned OFF, connect scan tool.
- 2) Turn ON ignition switch and clear DTC using scan tool.
- 3) Keep the accelerator pedal at idle position for 2 seconds.
- 4) Keep the accelerator pedal at fully depressed position for 2 seconds.
- 5) Repeat Step 3) and 4) for 3 times.
- 6) Check DTC.

**DTC Troubleshooting**

**NOTE**

Before this trouble shooting is performed, read the precautions for DTC troubleshooting referring to "Precautions For DTC Troubleshooting: ".

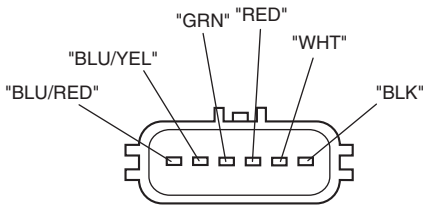
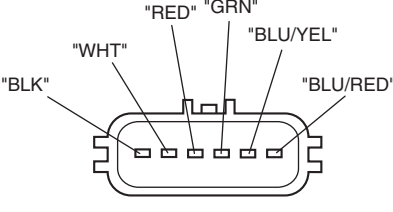
Step	Action	Yes	No
1	Was "Engine and Emission Control System Check" performed?	Go to Step 2.	Go to "Engine and Emission Control System Check: ".
2	<p><b>Throttle position sensor and its circuit check</b></p> <ol style="list-style-type: none"> <li>1) Connect scan tool to DLC with ignition switch turned OFF.</li> <li>2) Turn ON ignition switch, check "TP Sensor 1 Volt" displayed on scan tool when accelerator pedal is idle position and fully depressed.</li> </ol> <p>Is displayed TP sensor value as described voltage in "Scan Tool Data: "?</p>	<p>Intermittent trouble.</p> <p>Check for intermittent referring to "Intermittent and Poor Connection Inspection: in Section 00".</p>	Go to Step 3.
3	<p><b>ECM voltage check</b></p> <ol style="list-style-type: none"> <li>1) Disconnect connector from electric throttle body assembly with ignition switch turned OFF.</li> <li>2) Check for proper connection to electric throttle body assembly at "WHT", "GRN" and "BLK" wire terminals.</li> </ol> <p style="text-align: center;"><b>For J20 engine</b></p>  <p style="text-align: right;">I5JB0A110042-01</p> <p style="text-align: center;"><b>For M16 engine</b></p>  <p style="text-align: right;">I5JB0A110043-01</p> <ol style="list-style-type: none"> <li>3) If OK, measure voltage between "WHT" wire terminal of electric throttle body assembly connector and engine ground with ignition switch turned ON.</li> </ol> <p>Is voltage 4 – 6 V?</p>	Go to Step 6.	Go to Step 4.

**DTC Confirmation Procedure**

- 1) With ignition switch turned OFF, connect scan tool.
- 2) Turn ON ignition switch and clear DTC using scan tool.
- 3) Keep the accelerator pedal at idle position for 2 seconds.
- 4) Keep the accelerator pedal at fully depressed position for 2 seconds.
- 5) Repeat Step 3) and 4) for 3 times.
- 6) Check DTC.

**DTC Troubleshooting**

**NOTE**

Before this trouble shooting is performed, read the precautions for DTC troubleshooting referring to "Precautions For DTC Troubleshooting: ".

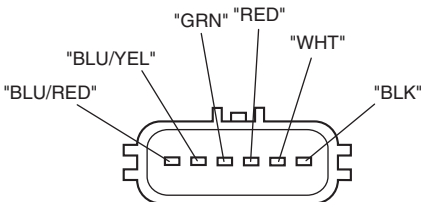
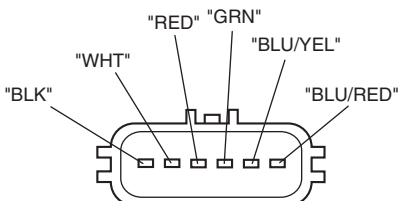
Step	Action	Yes	No
1	Was "Engine and Emission Control System Check" performed?	Go to Step 2.	Go to "Engine and Emission Control System Check: ".
2	<p><b>Throttle position sensor and its circuit check</b></p> <ol style="list-style-type: none"> <li>1) Connect scan tool to DLC with ignition switch turned OFF.</li> <li>2) Turn ON ignition switch, check "TP Sensor 2 Volt" displayed on scan tool when accelerator pedal is idle position and fully depressed.</li> </ol> <p>Is displayed TP sensor value as described voltage in "Scan Tool Data: "?</p>	<p>Intermittent trouble.</p> <p>Check for intermittent referring to "Intermittent and Poor Connection Inspection: in Section 00".</p>	Go to Step 3.
3	<p><b>ECM voltage check</b></p> <ol style="list-style-type: none"> <li>1) Disconnect connector from electric throttle body assembly with ignition switch turned OFF.</li> <li>2) Check for proper connection to electric throttle body assembly at "RED", "WHT" and "GRN" wire terminals.</li> </ol> <p style="text-align: center;"><b>For J20 engine</b></p>  <p style="text-align: center;"><b>For M16 engine</b></p>  <ol style="list-style-type: none"> <li>3) If OK, measure voltage between "WHT" wire terminal of electric throttle body assembly connector and engine ground with ignition switch turned ON.</li> </ol> <p>Is voltage 4 – 6 V?</p>	Go to Step 5.	Go to Step 4.

DTC P0401 / P0402: Exhaust Gas Recirculation Flow Insufficient Detected / Excessive Detected

S5JB0A1104042

System and Wiring Diagram

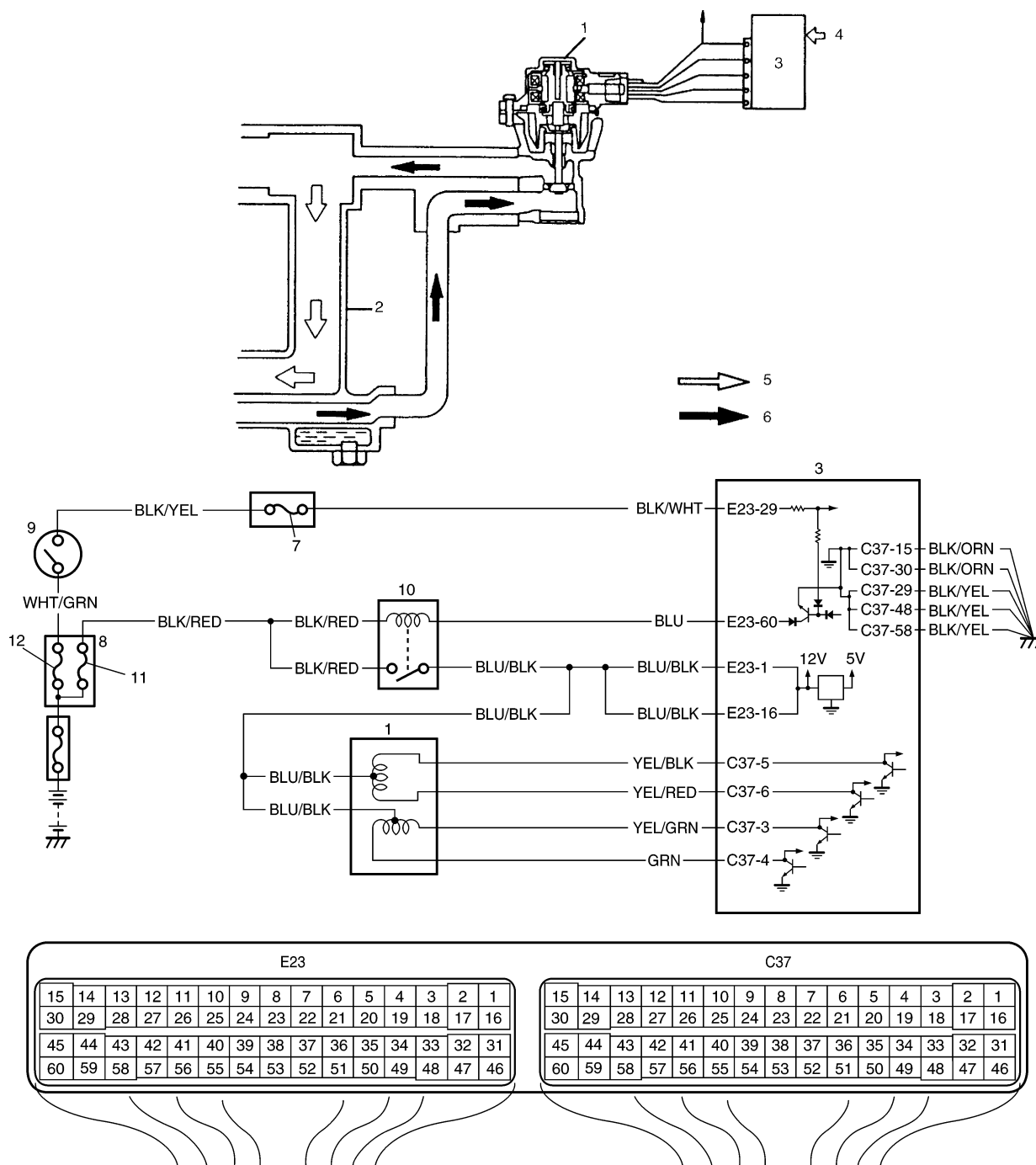

I5JB0A110051-01

1. EGR valve	4. Sensed information	7. "IG COIL" fuse	10. Main relay
2. Intake manifold	5. Fresh air	8. Fuse box No.2	11. "FI" fuse
3. ECM	6. Exhaust gas	9. Ignition switch	12. "IGN" fuse

Step	Action	Yes	No
18	<b>Wire circuit check</b> 1) Measure voltage between "RED/YEL" wire terminal of radiator cooling fan relay No.3 connector and vehicle body ground with ignition switch turned ON.  <i>Is voltage 0 V?</i>	Go to Step 19.	"RED/YEL" wire is shorted to other circuit.
19	<b>Wire circuit check</b> 1) Measure resistance between "RED/YEL" wire terminal of radiator cooling fan relay No.3 connector and "E23-48" terminal of ECM connector with ignition switch turned OFF.  <i>Is resistance below 5 Ω?</i>	Go to Step 20.	"RED/YEL" wire is open circuit
20	<b>Radiator cooling fan relay check</b> 1) Check radiator cooling fan relay referring to "Radiator Cooling Fan Relay Inspection: in Section 1F".  <i>Is it in good condition?</i>	Substitute a known-good ECM and recheck.	Replace relay.

**DTC P0500: Vehicle Speed Sensor (VSS) Malfunction**

S5JB0A1104049

**Wiring Diagram**

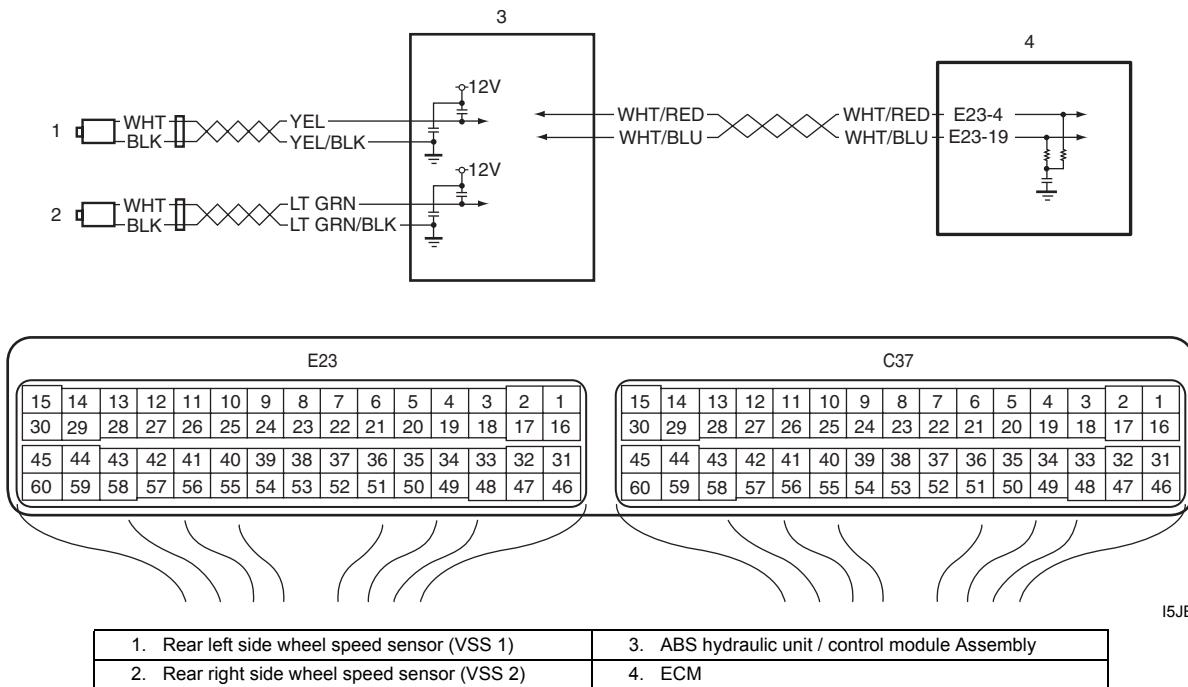

I5JB0A110060-03

**DTC Detecting Condition and Trouble Area**

DTC detecting condition	Trouble area
<ul style="list-style-type: none"> <li>Vehicle speed signal is not input while fuel is cut at deceleration for 4 seconds continuously at 3600 rpm or less.</li> <li>Vehicle speed signal is not input even if engine is running with more than 3700 rpm at D-Range for 4 sec. (for A/T model).</li> </ul> (2 driving cycle detection logic)	<ul style="list-style-type: none"> <li>Wheel speed sensor (VSS)</li> <li>Wheel speed sensor circuit</li> <li>ABS hydraulic unit / control module assembly</li> <li>ECM</li> </ul>

**DTC P1501 / P1502: Electric Load Current Sensor Circuit Low / High**

S5JB0A1104093

**System and Wiring Diagram**

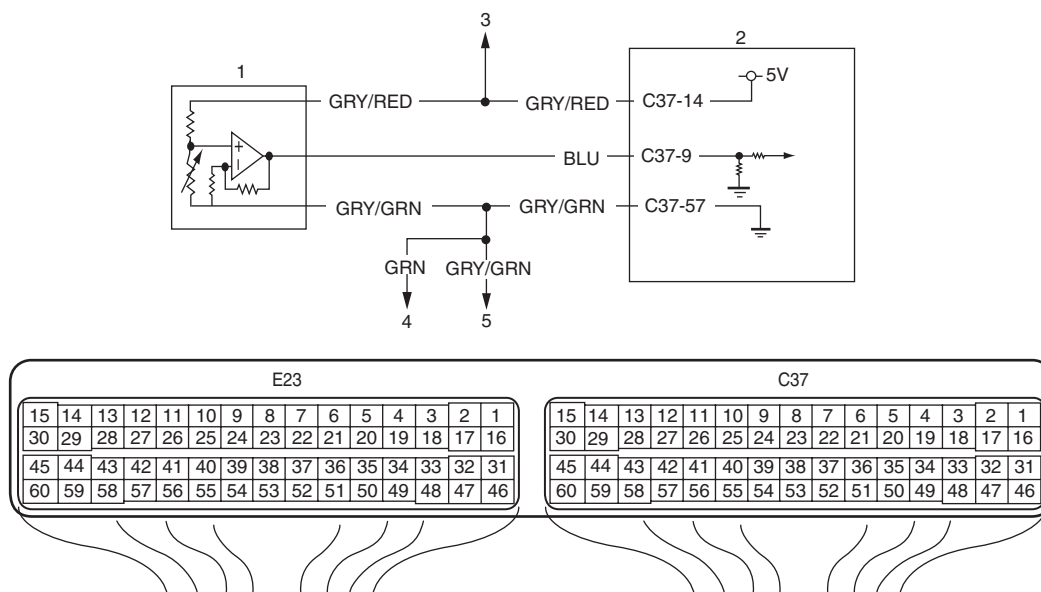

I5JB0A110065-01

1. Electric load current sensor	3. To other sensors (MAP, CO adjust resistor (if equipped), A/C refrigerant pressure (if equipped))	5. To other sensors (IAT, ECT, MAP, CO adjust resistor (if equipped), A/C refrigerant pressure (if equipped))
2. ECM	4. To HO2S-2	

**Electric Load Current Sensor Description**

Refer to “Generator Control System Description: ”.

**DTC Detecting Condition and Trouble Area**

DTC detecting condition	Trouble area
<p><b>P1501:</b> Electric load current sensor circuit voltage is lower than specified range.</p> <p><b>P1502:</b> Electric load current sensor circuit voltage is higher than specified range.</p>	Electric load current sensor and/or its circuit ECM

**NOTE**

**When DTC P0107 and P0532 are indicated together, it is possible that “GRY/RED” wire circuit open.**

**DTC Confirmation Procedure**

- 1) With ignition switch turned OFF, connect scan tool to DLC.
- 2) Turn ON ignition switch and clear DTC.
- 3) Make sure that all accessory switch is tuned OFF.
- 4) Start engine and warm it up to normal operating temperature (ECT approx. 90 – 95 °C, 193 – 203 °F).
- 5) Increase engine speed to 3000 rpm.
- 6) In this state, Turn ON following accessory switch.
  - Head lights switch.
  - Blower motor switch (max position).
  - Rear defogger switch.
- 7) Decrease engine speed to idle.
- 8) Check DTC and pending DTC.

**DTC P1685: CAN Communication (Reception Error for ABS Control Module)**

S5JB0A1104094

**Wiring Diagram**

Refer to "DTC P1674: CAN Communication (Bus Off Error):".

**DTC Detecting Condition and Trouble Area**

DTC detecting condition	Trouble area
Reception error of communication data for ABS hydraulic unit / control module assembly is detected for longer than specified time continuously. (1 driving detection logic)	<ul style="list-style-type: none"> <li>• ECM</li> <li>• ABS hydraulic unit / control module assembly</li> <li>• CAN communication line circuit</li> </ul>

**DTC Confirmation Procedure**

- 1) Connect scan tool to DLC with ignition switch turned OFF.
- 2) Turn ON ignition switch and clear DTC by using scan tool.
- 3) Start engine and run it for 1 min. or more.
- 4) Check DTC.

**DTC Troubleshooting**

**NOTE**

Before this trouble shooting is performed, read the precautions for DTC troubleshooting referring to "Precautions For DTC Troubleshooting:".

Step	Action	Yes	No
1	Was "Engine and Emission Control System Check" performed?	Go to Step 2.	Go to "Engine and Emission Control System Check:".
2	<p><b>DTC check</b></p> <p>1) Connect scan tool to DLC with ignition switch turned OFF.</p> <p>2) Check ECM, TCM (for A/T model), ABS hydraulic unit / control module assembly, 4WD control module (for J20 engine), keyless start control module (if equipped) and BCM for DTC.</p> <p><i>Is there any DTC(s) other than CAN communication DTC(s) at each control module (other than DTC P1618, P1674, P1676, P1678, P1685 in ECM, DTC P1774, P1777, P1778 in TCM (for A/T model), DTC U1073, U1100, U1101, U1121 in BCM, ABS hydraulic unit / control module assembly and 4WD control module (for J20 engine), and DTC No.31 / 33 in keyless start control module (if equipped))?</i></p>	Go to applicable DTC diag. flow.	Go to Step 3.
3	<p><b>Check CAN communication error for ECM</b></p> <p>1) Check ECM for DTC.</p> <p><i>Is there DTC P1674?</i></p>	Go to "DTC P1674: CAN Communication (Bus Off Error):".	Go to Step 4.
4	<p><b>ECM and ABS hydraulic unit / control module connector check</b></p> <p>1) Check for proper connection at each ECM and ABS hydraulic unit / control module connector terminals with ignition switch turned OFF.</p> <p>2) If connections are OK, recheck ECM for DTC with engine running.</p> <p><i>Is there DTC P1685?</i></p>	Go to Step 5.	Intermittent trouble. Check for intermittent referring to "Intermittent and Poor Connection Inspection: in Section 00".

DTC Troubleshooting

NOTE

Before this trouble shooting is performed, read the precautions for DTC troubleshooting referring to "Precautions For DTC Troubleshooting: ".

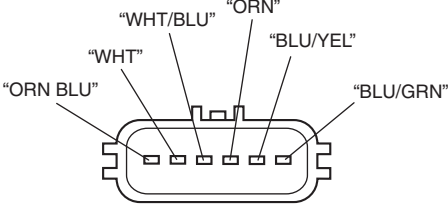
Step	Action	Yes	No
1	Was "Engine and Emission Control System Check" performed?	Go to Step 2.	Go to "Engine and Emission Control System Check: ".
2	<p><b>Accelerator pedal position (APP) sensor assembly mounting check</b></p> <p>1) Check that accelerator pedal position (APP) sensor assembly has been mounted to vehicle body properly (no pinched floor carpet, etc).</p> <p><i>Is it OK?</i></p>	Go to Step 3.	Reinstall accelerator pedal position (APP) sensor assembly properly referring to "Accelerator Pedal Position (APP) Sensor Assembly Removal and Installation: in Section 1C".
3	<p><b>Accelerator pedal position sensor (sub) and its circuit check</b></p> <p>1) Connect scan tool to DLC with ignition switch turned OFF.</p> <p>2) Turn ON ignition switch, check "APP Sensor 2 Volt" displayed on scan tool.</p> <p><i>Is displayed voltage below 0.1 V?</i></p>	Go to Step 4.	Intermittent trouble. Check for intermittent referring to "Intermittent and Poor Connection Inspection: in Section 00".
4	<p><b>ECM voltage check</b></p> <p>1) Disconnect connector from accelerator pedal position (APP) sensor assembly with ignition switch turned OFF.</p> <p>2) Check for proper connection to accelerator pedal position (APP) sensor assembly at "ORN/BLU", "BLU/GRN" and "BLU/YEL" wire terminals.</p> <div style="text-align: center;">  <p>I5JB0A110071-01</p> </div> <p>3) If OK, measure voltage between "ORN/BLU" wire terminal of accelerator pedal position (APP) sensor assembly connector and vehicle body ground with ignition switch turned ON.</p> <p><i>Is voltage 4 – 6 V?</i></p>	Go to Step 7.	Go to Step 5.
5	<p><b>ECM voltage check</b></p> <p>1) Turn OFF ignition switch.</p> <p>2) Remove ECM from its bracket with ECM connectors connected.</p> <p>3) Check for proper connection of ECM connector at "E23-53" terminal.</p> <p>4) If OK, measure voltage between "E23-53" terminal of ECM connector and engine ground with ignition switch turned ON.</p> <p><i>Is voltage 4 – 6 V?</i></p>	"ORN/BLU" wire is open or high resistance circuit.	Go to Step 6.

Terminal No.	Wire color	Circuit	Normal voltage	Condition	Remarks
C37-51	WHT/ BLU	CKP sensor signal (for M16 engine)	0 – 1 V or 4 – 5 V	Ignition switch turned ON.	—
			*4 – 5 V ↑↓ 0 – 0.6 V ("Reference waveform No.20: " and "Reference waveform No.21: ")	Engine running at idle after warmed up engine.	Sensor signal is pulse. Pulse frequency which varies depending on engine speed. (30 (36 – 6) pulses are generated per 1 crankshaft revolution.)
	GRN	Crankshaft position (CKP) sensor (+) (for J20 engine)	0 – 1 V	Ignition switch turned ON.	—
			*4 – 6 V ↑↓ –4 – –6 V ("Reference waveform No.20: " and "Reference waveform No.21: ")	Engine running at idle after warmed up engine.	Output signal is sinusoidal waveform. Waveform frequency varies depending on engine speed. (30 (36 – 6) pulses are generated per 1 crankshaft revolution.)
C37-52	WHT/ RED	CMP sensor signal	0 – 1 V or 4 – 5 V	Ignition switch turned ON.	—
			*0 – 0.6 V ↑↓ 4 – 5 V ("Reference waveform No.20: " and "Reference waveform No.21: ")	Engine running at idle after warmed up engine.	Sensor signal is pulse. Pulse frequency varies depending on engine speed. (6 pulses are generated per 1 camshaft revolution.)
C37-53	WHT	Output for 5 V power source of throttle position sensor	4.5 – 5.5 V	Ignition switch turned ON.	—
C37-54	BLK	Throttle position sensor (main) signal	0.72 – 1.04 V	Ignition switch turned ON and accelerator pedal at idle position after warmed up engine.	—
			3.67 – 4.25 V	Ignition switch turned ON and accelerator pedal at full depressed position after warmed up engine.	
C37-55	RED/ WHT	Manifold absolute pressure (MAP) sensor signal	Approx. 4 V ("Reference waveform No.24: ")	Ignition switch turned ON with barometric pressure at 100 kPa, 760 mmHg.	—
			0.4 – 2.0 V ("Reference waveform No.25: ")	While engine running at specified idle speed after warmed up with barometric pressure at 100 kPa, 760 mmHg.	
C37-56	WHT	Knock sensor signal	2 – 3 V ("Reference waveform No.26: " and "Reference waveform No.27: ")	Ignition switch turned ON.	—
				Engine running at 4000 r/min. after warmed up.	
C37-57	GRY/ GRN	Ground for sensors	Below 0.3 V	Ignition switch turned ON.	—
C37-58	BLK/ YEL	Ground for ECM	Below 0.3 V	Ignition switch turned ON.	—
C37-59	BRN/ YEL	Oil control valve ground (for M16 engine)	Below 1.3 V	Ignition switch turned ON.	—

## 1A-235 Engine General Information and Diagnosis:

### Circuit Description

When the ignition switch is turned ON, the main relay turns ON (the contact point closes) and the main power is supplied to ECM. And then ECM supplies 5 V power to each sensor (electric load current sensor (for J20 engine), MAP sensor, A/C refrigerant pressure sensor, APP sensor and TP sensor).

If 5 V power circuit to each sensors from ECM is shorted to ground, ECM stops engine and emission control operation.

### Troubleshooting

#### NOTE

- Before performed troubleshooting, be sure to read the “Precautions of ECM Circuit Inspection: ”.
- When measuring circuit voltage, resistance and/or pulse signal at ECM connector, connect the special tool to ECM and/or the ECM connectors referring to “Inspection of ECM and Its Circuits: ”.

Step	Action	Yes	No
1	<b>Circuit fuse check</b> 1) Disconnect connectors from ECM with ignition switch turned OFF. 2) Check for proper connection to ECM connector at “E23-2”, “E23-29”, “E23-60”, “E23-1”, “E23-16”, “C37-15”, “C37-30”, “C37-29”, “C37-48” and “C37-58” terminals. 3) If OK, check “RADIO” fuse and “IG COIL” fuse for blowing. <i>Are “DOME” fuse and “IG COIL” fuse in good condition?</i>	Go to Step 2.	Replace fuse (s) and check for short in circuits connected to fuse(s).
2	<b>Power supply circuit check</b> 1) Measure voltage between “E23-2” terminal of ECM connector and body ground. <i>Is voltage 10 – 14 V?</i>	Go to Step 3.	“WHT” wire is open circuit.
3	<b>Ignition signal check</b> 1) Turn ignition switch to ON position. 2) Measure voltage between “E23-29” terminal of ECM connector and body ground. <i>Is voltage 10 – 14 V?</i>	Go to Step 4.	“BLK/WHT” or “BLK/YEL” wire is open circuit.

Step	Action	Yes	No
7	<p><b>Wire circuit check</b></p> <p>1) Disconnect radiator cooling fan motor No.1 connector with ignition switch turned OFF.</p> <p>2) Measure resistance between “BLU/YEL” wire terminal of radiator cooling fan relay No.2 connector and vehicle body ground.</p> <p><i>Is resistance infinity?</i></p>	Go to Step 8.	“BLU/YEL” wire is shorted to ground circuit.
8	<p><b>Wire circuit check</b></p> <p>1) Measure voltage between “BLU/YEL” wire terminal of radiator cooling fan relay No.2 connector and vehicle body ground with ignition switch turned ON.</p> <p><i>Is voltage 0 V?</i></p>	Go to Step 9.	“BLU/YEL” wire is shorted to other circuit.
9	<p><b>Wire circuit check</b></p> <p>1) Measure resistance between “BLU/YEL” wire terminal of radiator cooling fan relay No.2 connector and radiator cooling fan motor No.1 connector with ignition switch turned OFF.</p> <p><i>Is resistance below 5 Ω?</i></p>	Go to Step 16.	“BLU/YEL” wire is open circuit.
10	<p><b>Radiator cooling fan control check</b></p> <p>1) Disconnect connector from radiator cooling fan motor No.2 and connect radiator cooling fan relay No.2 with ignition switch turned OFF.</p> <p>2) Run engine until ECT is over 97.5 °C, 207.5 °F.</p> <p>3) Measure voltage between “BLU” wire terminals of radiator cooling fan motor No.2 connector and vehicle body ground.</p> <p><i>Is voltage 10 – 14 V?</i></p>	Go to Step 14.	Go to Step 11.
11	<p><b>Wire circuit check</b></p> <p>1) Disconnect radiator cooling fan relay No.2 with ignition switch turned OFF.</p> <p>2) Measure resistance between “BLU” wire terminal of radiator cooling fan relay No.2 connector and vehicle body ground.</p> <p><i>Is resistance infinity?</i></p>	Go to Step 12.	“BLU” wire is shorted to ground circuit.
12	<p><b>Wire circuit check</b></p> <p>1) Measure voltage between “BLU” wire terminal of radiator cooling fan relay No.2 connector and vehicle body ground with ignition switch turned ON.</p> <p><i>Is voltage 0 V?</i></p>	Go to Step 13.	“BLU” wire is shorted to other circuit.
13	<p><b>Wire circuit check</b></p> <p>1) Measure resistance between “BLU” wire terminals of radiator cooling fan relay No.2 connector and radiator cooling fan motor No.2 connector with ignition switch turned OFF.</p> <p><i>Is resistance below 3 Ω?</i></p>	Go to Step 15.	“BLU” wire is open circuit.
14	<p><b>Wire circuit check</b></p> <p>1) Measure resistance between “BLK” wire terminal of radiator cooling fan motor No.2 connector and vehicle body ground with ignition switch turned OFF.</p> <p><i>Is resistance below 3 Ω?</i></p>	Go to Step 16.	“BLK” wire is open circuit.

## 1C-7 Engine Electrical Devices:

### Installation

Reverse removal procedure noting the following.

- Clean mating surfaces of ECT sensor and water outlet cap.
- Check O-ring for damage and replace, if necessary.
- Tighten ECT sensor (1) to specified torque.

#### Tightening torque

ECT sensor (a): **12.5 N·m (1.25 kgf-m, 9.0 lb-ft)**

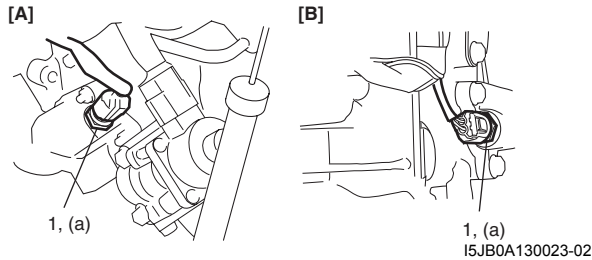

[A]: For J20 engine
[B]: For M16 engine

- Connect connector to ECT sensor securely.
- Refill coolant referring to “Cooling System Flush and Refill: in Section 1F”.

### Engine Coolant Temperature (ECT) Sensor Inspection

S5JB0A1306009

Immerse temperature sensing part of ECT sensor in water (or ice) and measure resistance between sensor terminals while heating water gradually. If measured resistance doesn't show such characteristic as shown, replace ECT sensor.

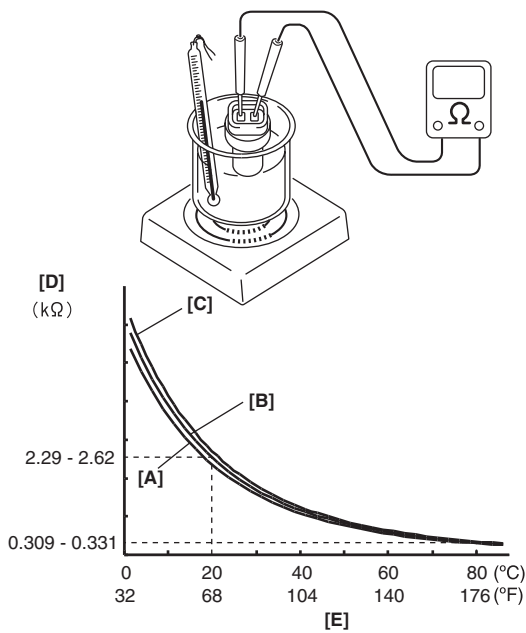

I5JB0A130037-01

[A]: Lower limit	[D]: Resistance
[B]: Normal	[E]: Temperature
[C]: Upper limit	

### Air Fuel Ratio (A/F) Sensor On-Vehicle Inspection

S5JB0A1306028

#### Heater

- 1) Disconnect A/F sensor connector.
- 2) Using ohmmeter, measure resistance of Sensor heater between terminals “V<sub>B</sub>” and “GND” at sensor connector. If found faulty, replace A/F sensor.

#### NOTE

Temperature of sensor affects resistance value largely. Make sure that sensor heater is at correct temperature.

#### A/F sensor heater resistance

**2 – 3 Ω at 20 °C (68 °F)**

#### Viewed from terminal side

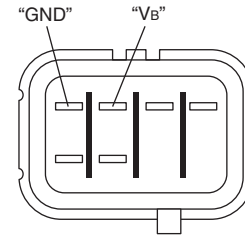

I5JB0A130001-02

- 3) Connect A/F sensor connector securely.

#### Adjusting Resistor

- 1) Disconnect A/F sensor connector.
- 2) Using ohmmeter, measure resistance of adjusting resistor between terminals “R+” and “R-” at A/F sensor connector. If found faulty, replace A/F sensor.

#### Adjusting resistor resistance

**100 – 58000 Ω at 20 °C (68 °F)**

#### Viewed from terminal side

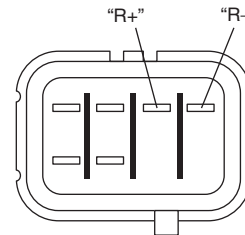

I5JB0A130002-02

- 3) Connect A/F sensor connector securely.

**Special tool selection table**

No. on camshaft housing	Embossed mark on special tool
I2	IN2
I3, I4, I5	IN345
E2	EX2
E3, E4, E5	EX345

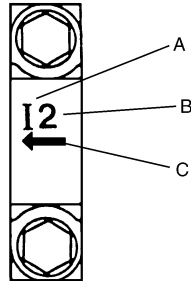

I2RH0B140011-01

A: I: Intake side or E: Exhaust side
B: Position from timing chain side
C: Pointing to timing chain side

- c) Hold down the tappet so as not to contact the shim by installing special tool on camshaft housing with housing bolt (1) tighten housing bolts to specified torque.

**Special tool**

(A): 09916-67020

(A): 09916-67021

**Tightening torque**

Camshaft housing bolts (a): 8 N·m (0.8 kgf·m, 6.0 lb·ft) for tightening of special tool

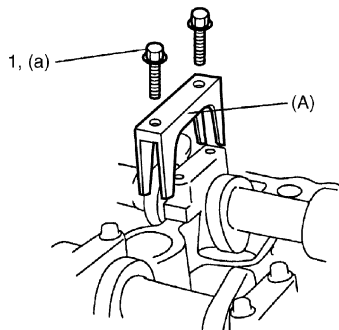

I3RM0A140005-01

- 4) Turn camshaft by approximately 90° clockwise and remove shim (3).

**▲ WARNING**

**Never put in the hand between camshaft and tappet.**

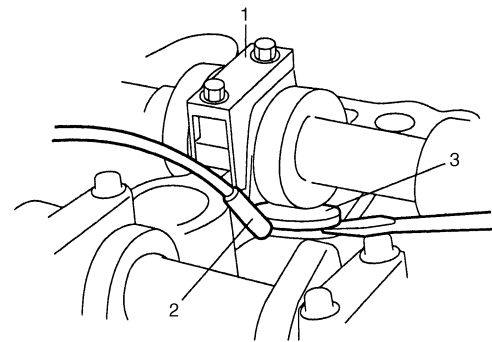

I2RH0B140013-01

1. Special tool	2. Magnet
-----------------	-----------

- 5) Using a micrometer (2), measure the thickness of the removed shim (1), and determine replacement shim by calculating the thickness of new shim with the following formula and table.

**Shim thickness specification**

**Intake side:**

$$A = B + C - 0.20 \text{ mm (0.008 in.)}$$

**Exhaust side:**

$$A = B + C - 0.30 \text{ mm (0.012 in.)}$$

**A: Thickness of new shim**

**B: Thickness of removed shim**

**C: Measured valve clearance**

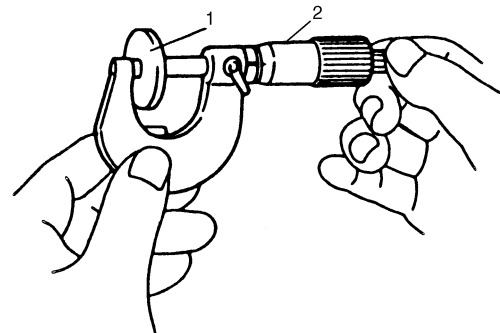

I2RH0B140014-01

**For example of intake side:**

When thickness of removed shim is 2.40 mm (0.094 in.), and measured valve clearance is 0.45 mm (0.018 in.).

$$A = 2.40 \text{ mm (0.094 in.)} + 0.45 \text{ mm (0.018 in.)} - 0.20 \text{ mm (0.008 in.)} = 2.65 \text{ mm (0.104 in.)}$$

Calculated thickness of new shim = 2.65 mm (0.104 in.)

Installation

**⚠ CAUTION**

After timing chain is removed, never turn crankshaft and camshafts independently more than such an extent ("a", "b") as shown in the figure.

If turned, interference may occur between piston and valves and valves themselves, and parts related to piston and valves may be damaged.

- 1) Check that match marks (1) on intake and exhaust camshaft timing sprockets are in match with notches (2) on cylinder head as shown in the figure.
- 2) Set key (3) and turn crankshaft to position key on upside of crankshaft.

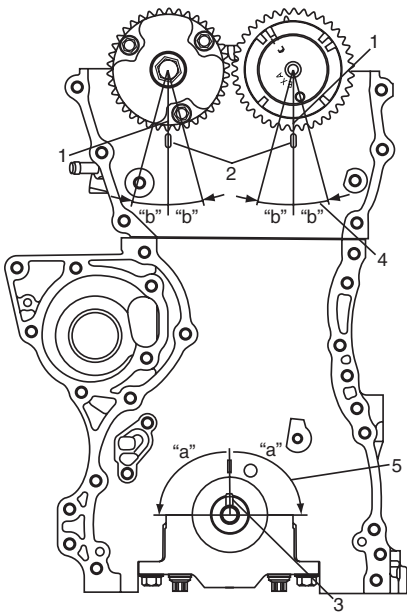

I4RSOA140021-01

"a": 90°	4. Camshaft (IN and EX) allowable turning range. By marks on camshaft timing sprocket within 15° from notches on cylinder head on both right and left.
"b": 15°	5. Crankshaft allowable turning range. By key on crankshaft, within 90° from top on both right and left.

- 3) Install timing chain by aligning dark blue plate (1) of timing chain and triangle mark (2) on camshaft timing sprocket as shown in the figure.
- 4) Fit crankshaft timing sprocket to timing chain by aligning gold plate (3) of timing chain and circle mark (4) on crankshaft timing sprocket. Then install crankshaft timing sprocket fitted with chain to crankshaft.

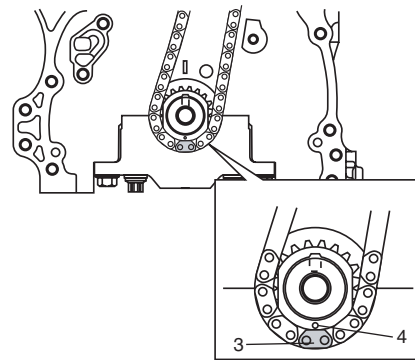
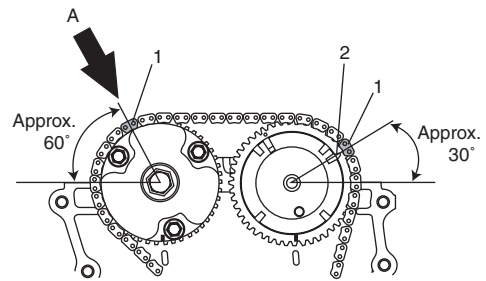
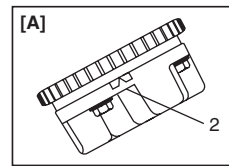

I3RHOB140034-01

[A]: View A

- 5) Apply engine oil to sliding surface of timing chain No.1 guide (1) and install it as shown in the figure. Tighten guide bolts to specified torque.

**Tightening torque**

Timing chain No.1 guide bolt (a): 11 N·m (1.1 kgf-m, 8.0 lb-ft)

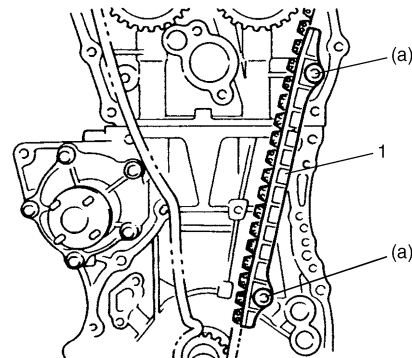

I2RHOB140062-01

**Cylinder Head Bolt**

Measure each thread diameter of cylinder head bolt (1) at "A" on 83.5 mm (2.81 in.) from seat side of flange bolt and "B" on 115 mm (4.53 in.) from seat side of flange bolt by using a micrometer (2). Then calculate difference in diameters ("A" – "B"). If it exceeds limit, replace with new one.

**Cylinder head bolt diameter measurement points**

"a": 83.5 mm (2.81 in.)  
 "b": 115 mm (4.53 in.)

**Cylinder head bolt diameter difference (deformation)**

Limit ("A" – "B"): 0.1 mm (0.004 in.)

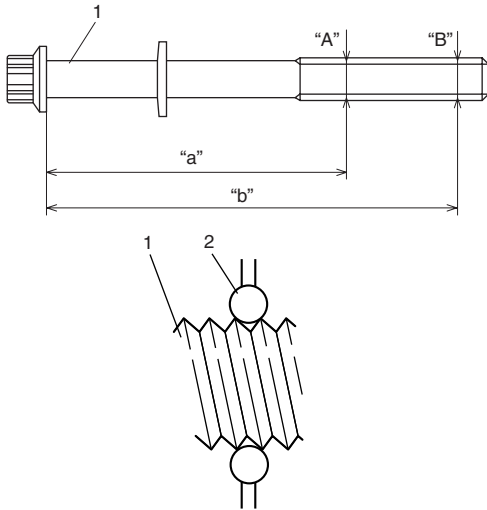

I2RH0B140092-01

**Valve Spring Inspection**

S5JB0A1416028

**Valve Spring Free Length and Preload**

Referring to data, check to be sure that each spring is in sound condition, free of any evidence of breakage or weakening. Remember, weakened valve springs can cause chatter, not to mention possibility of reducing power output due to gas leakage caused by decreased seating pressure.

**Valve spring free length**

Standard: 36.83 mm (1.450 in.)  
 Limit: 35.83 mm (1.411 in.)

**Valve spring preload**

Standard: 107 – 125 N (10.7 – 12.5 kg) for 31.50 mm (23.6 – 27.6 lb/1.240 in.)  
 Limit: 102 N (10.2 kg) for 31.50 mm (22.5 lb/1.240 in.)

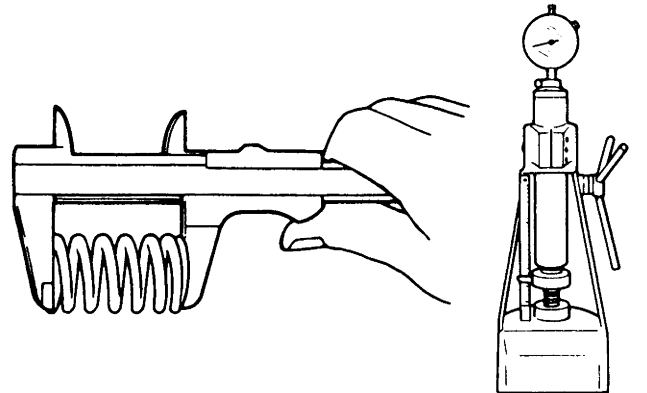

I2RH01140143-01

**Spring Squareness**

Use a square and surface plate to check each spring for squareness in terms of clearance between end of valve spring and square. Valve springs found to exhibit a larger clearance than limit must be replaced.

**Valve spring squareness**

Limit: 1.6 mm (0.063 in.)

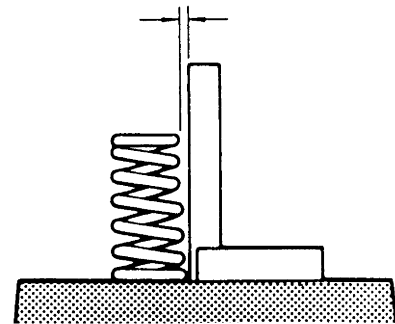

I2RH01140144-01

- 4) Tighten main bearing cap No.1 bolts (1) – (10) and main bearing cap No.2 bolts (11) – (20) gradually as follows.

**NOTE**

**If main bearing cap No.1 bolt is reused, make sure to check main bearing cap No.1 bolt for deformation referring to “Main Bearing Cap No.1 Bolt” under “Main Bearings Inspection: For M16A Engine with VVT”.**

- a) Tighten bolts (1) – (10) to 30 N·m (3.0 kgf·m, 22.0 lb-ft) according to numerical order in the figure.
- b) In the same manner as in Step a), tighten them to 50 N·m (5.0 kgf·m, 36.5 lb-ft).
- c) In the same manner as in Step a), retighten them to 60°.
- d) Tighten bolts (11) – (20) to 25 N·m (2.5 kgf·m, 18.0 lb-ft) according to numerical order in the figure.

**Tightening torque**

**Main bearing cap No.1 bolt ((1) – (10)): 30 Nm (3.0 kgf·m, 22.0 lb-ft), 50 Nm (5.0 kgf·m, 36.5 lb-ft) and then retighten by turning through 60°**

**Main bearing cap No.2 bolt ((11) – (20)): 25 N·m (2.5 kgf·m, 18.0 lb-ft)**

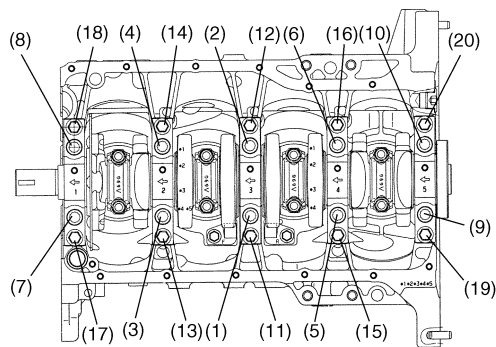

I2RH0B140137-01

- 5) Remove bearing caps and using scale (1) on gauging plastic envelop (2), measure gauging plastic width at its widest point. If clearance exceeds its limit, replace bearing. Always replace both upper and lower inserts as a unit.

A new standard bearing may produce proper clearance. If not, it will be necessary to regrind crankshaft journal for use of 0.25 mm undersize bearing.

After selecting new bearing, recheck clearance.

**Main bearing clearance**

**Standard: 0.021 – 0.041 mm (0.0008 – 0.0016 in.)**

**Limit: 0.054 mm (0.0021 in.)**

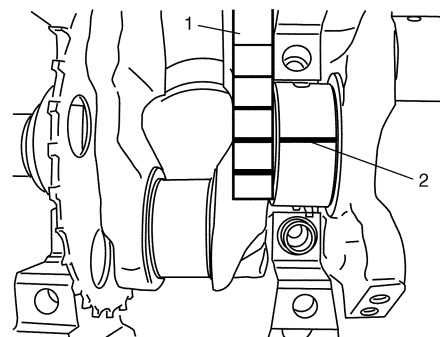

I2RH0B140141-01

**Selection of Main Bearings**

**Standard bearing**

If bearing is in malcondition, or bearing clearance is out of specification, select a new standard bearing according to the following procedure and install it.

- 1) First check journal diameter. As shown in the figure, crank web No.2 has stamped numbers. Three kinds of numbers (“1”, “2” and “3”) represent the following journal diameters. Stamped numbers on crank web No.2 represent journal diameters marked with an arrow in the figure respectively. For example, stamped number “1” indicates that corresponding journal diameter is 51.9940 – 52.0000 mm (2.0471 – 2.0472 in.).

**Crankshaft journal diameter**

Stamped numbers	Journal diameter
1	51.9940 – 52.0000 mm (2.0471 – 2.0472 in.)
2	51.9880 – 51.9939 mm (2.0468 – 2.0470 in.)
3	51.9820 – 51.9879 mm (2.0465 – 2.0467 in.)

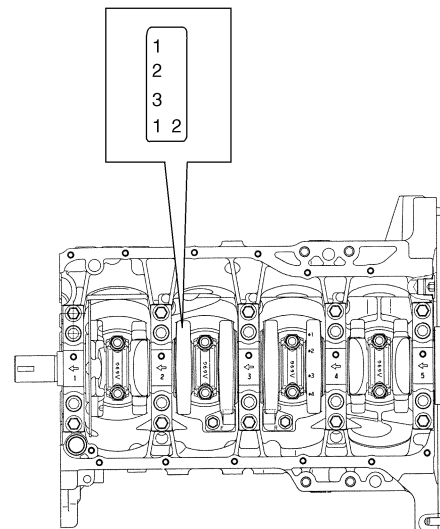

I2RH0B140142-01

## Repair Instructions

### Air Cleaner Assembly Removal and Installation

S5JB0A1426044

#### Removal

- 1) Disconnect breather hose (1) from air cleaner outlet hose (2).
- 2) Remove air cleaner outlet hose (2).
- 3) Disconnect MAF sensor connector (3).
- 4) Remove air cleaner case (4).

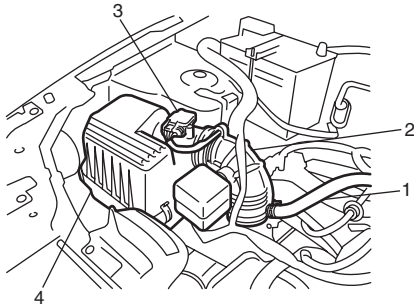

I5JB0A142003-01

#### Installation

- 1) Install air cleaner case (4).
- 2) Connect MAF sensor connector (3).
- 3) Install air cleaner outlet hose (2).
- 4) Connect breather hose (1) to air cleaner outlet hose (2).

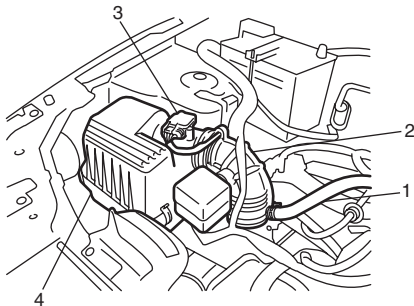

I5JB0A142003-01

### Air Cleaner Filter Removal and Installation

S5JB0A1426002

#### Removal

- 1) Remove air cleaner upper case (1) from lower case after hooking clamps (2) from upper case.
- 2) Remove air cleaner filter.

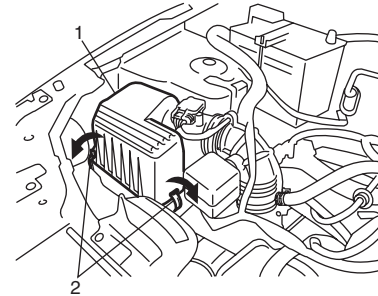

I5JB0A142004-01

#### Installation

Reverse removal procedure for installation.

### Air Cleaner Filter Inspection and Cleaning

S5JB0A1426003

#### Inspection

Check air cleaner filter for dirt.

#### Cleaning

Blow off dust by compressed air from air outlet side of element.

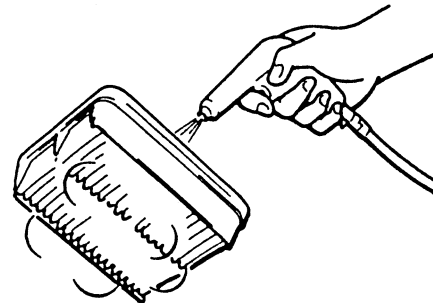

I2RH01140007-01

## 1st Timing Chain and Chain Tensioner Removal and Installation

S5JB0A1426027

### ⚠ CAUTION

After timing chain is removed, never turn crankshaft and camshafts independently more than its allowable turning range described referring to "2nd Timing Chain and Chain Tensioner Removal and Installation: For J20 Engine".

If turned, interference may occur between piston and valves and valves themselves, and parts related to piston and valves may be damaged.

### Removal

- 1) Remove 2nd timing chain. Refer to "2nd Timing Chain and Chain Tensioner Removal and Installation: For J20 Engine" for removal.
- 2) Remove timing chain guide No.1 (1).
- 3) Remove timing chain tensioner adjuster No.1 (2).
- 4) Remove timing chain tensioner (3).
- 5) Remove idler sprocket (4) and 1st timing chain (5).
- 6) Remove crankshaft timing sprocket (6).

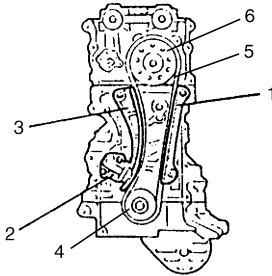

I4RH01140029-01

### Installation

- 1) Install crankshaft timing sprocket (2) as shown in figure.

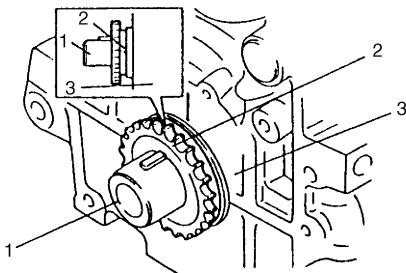

I2RH01140083-01

1. Crankshaft	3. Cylinder block
---------------	-------------------

- 2) Check that match mark (1) on crankshaft timing sprocket is in match with timing mark (2) on lower crankcase.

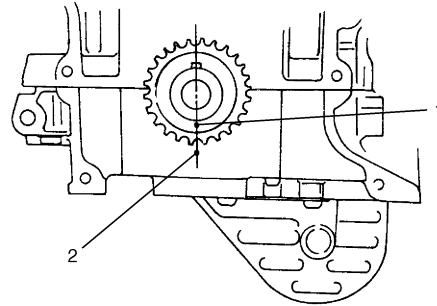

I2RH01140082-01

- 3) Apply oil to bush of idler sprocket (1).
- 4) Install idler sprocket and sprocket shaft.
- 5) Install 1st timing chain by aligning dark blue plate (4) of 1st timing chain (3) and match mark (2) on idler sprocket (1).

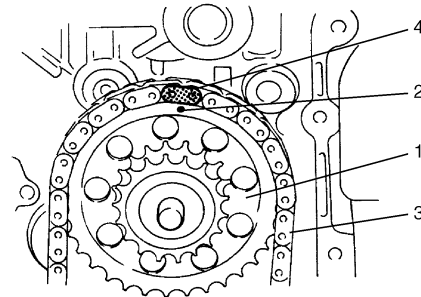

I2RH01140084-01

- 6) Bring gold plate (4) of 1st timing chain (3) into match with match mark (2) on crankshaft timing sprocket (1).

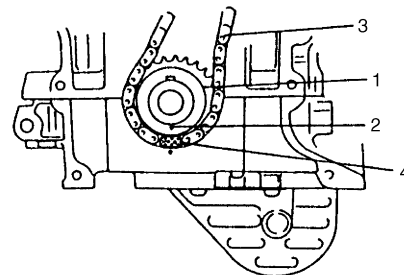

I2RH01140085-01

- 7) Apply engine oil to sliding surface of timing chain tensioner (1) and then install it as shown in figure. Tighten tensioner nut to specified torque.

### Tightening torque

Timing chain tensioner nut (a): 25 N·m (2.5 kgf-m, 18.0 lb-ft)

- 3) Install piston and connecting rod assembly into cylinder bore. Use special tool (Piston ring compressor) to compress rings. Guide connecting rod into place on crankshaft. Using a hammer handle, tap piston head to install piston into bore. Hold ring compressor firmly against cylinder block until all piston rings have entered cylinder bore.

**Special tool**  
**(A): 09916-77310**

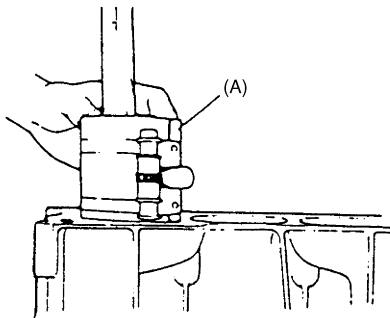

I2RH01140149-01

- 4) Install connecting rod bearing cap (1) as follows.

**NOTE**

**If connecting rod bolt is reused, make sure to check connecting rod bolt for deformation referring to “Connecting Rod Bolt Deformation (Plastic Deformation Tightening Bolt)” under “Pistons, Piston Rings, Connecting Rods and Cylinders Inspection and Cleaning: For J20 Engine”.**

- a) Point arrow mark (2) on cap to crankshaft pulley side.
- b) Apply engine oil to new connecting rod bolts (3).
- c) Tighten all connecting rod bolts to 15 N·m (1.5 kgf-m, 11.0 lb-ft).
- d) Retighten them by turning through 45°.
- e) Repeat step d) once again.

**Tightening torque**

**Connecting rod bolt (a): Tighten 15 N·m (1.5 kgf-m, 11.0 lb-ft), 45° and 45° by the specified procedure.**

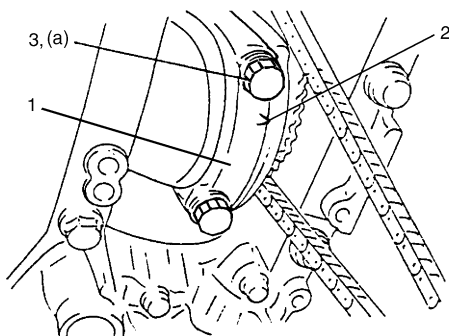

I4RH01140037-01

- 5) Install cylinder head. Refer to “Valves and Cylinder Head Removal and Installation: For J20 Engine” for installation.
- 6) Install oil pan. Refer to “Oil Pan and Oil Pump Strainer Removal and Installation: For J20 Engine in Section 1E” for installation.
- 7) Install engine assembly to vehicle referring to “Engine Assembly Removal and Installation: For J20 Engine”.

**Pistons, Piston Rings, Connecting Rods and Cylinders Disassembly and Assembly**

S5JB0A1426038

**Disassembly**

- 1) Using piston ring expander, remove two compression rings (Top and 2nd) and oil ring from piston.
- 2) Remove piston pin from connecting rod.
  - Ease out piston pin circlips (1), as shown.

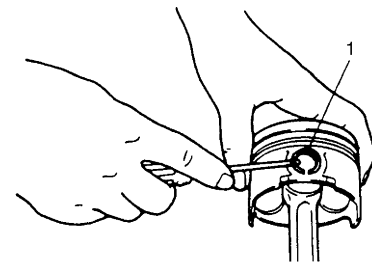

I2RH01140151-01

- Force piston pin out.

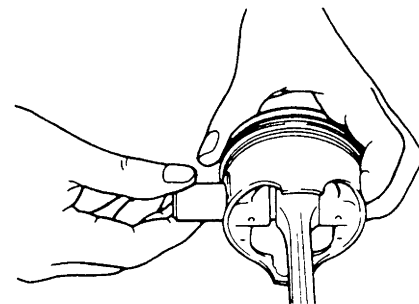

I2RH01140152-01

4) From number stamped on crank web No.2 and alphabets stamped on lower crankcase, determine new standard bearing to be installed to journal by referring to table shown.  
 For example, if number stamped on crank web No.2 is “5” and alphabet stamped on lower crankcase is “A”, install new standard bearings painted in “Green” to cylinder block side journal and “Black” to lower crankcase side journal.

**NOTE**

The meaning of “Upper” and “Lower” described in below table are the following.

- Upper: It is instruction of main bearing installed in cylinder block side journal.
- Lower: It is instruction of main bearing installed in lower crankcase side journal.

**Main bearing cross-reference table (new standard bearing)**

		Standard number on crank web No.2					
		4	5	6	7	8	9
Standard alphabet on lower crankcase	A	Green	Upper: Green Lower: Black	Black	Upper: Black Lower: Colorless	Colorless	Upper: Colorless Lower: Yellow
	B	Black	Upper: Black Lower: Colorless	Colorless	Upper: Colorless Lower: Yellow	Yellow	Upper: Yellow Lower: Blue
	C	Colorless	Upper: Colorless Lower: Yellow	Yellow	Upper: Yellow Lower: Blue	Blue	Blue

5) Check main bearing clearance with newly selected standard bearing referring to “Main Bearing Clearance”.  
 If clearance still exceeds its limit, use next thicker bearing and recheck clearance.

**UNDERSIZE BEARING (0.25 mm):**

- 0.25 mm undersize bearing is available, in five kinds varying in thickness.  
 To distinguish them, each bearing is painted (1) in the following colors at such position as indicated in figure.  
 Each color represents the following thickness at the center of bearing.

**Undersize main bearing thickness**

Color painted	Bearing thickness
Green & Red	2.1160 – 2.1190 mm (0.08331 – 0.08342 in.)
Black & Red	2.1190 – 2.1220 mm (0.08343 – 0.08354 in.)
Red only	2.1220 – 2.1250 mm (0.08355 – 0.08366 in.)
Yellow & Red	2.1250 – 2.1280 mm (0.08367 – 0.08377 in.)
Blue & Red	2.1280 – 2.1310 mm (0.08378 – 0.08389 in.)

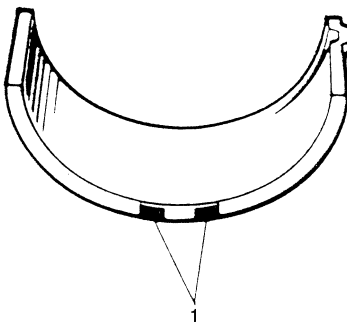

## For J20 Engine

### General Description

#### Engine Lubrication Description

S5JB0A1521001

The oil pump is trochoid type, and mounted under the crankshaft. Oil is drawn up through the oil pump strainer and passed through the pump to the oil filter.

The filtered oil flows into two paths in cylinder block.

In one path, oil reaches the crankshaft journal bearings. Oil from the crankshaft journal bearings is supplied to the connecting rod bearings by means of intersecting passages drilled in the crankshaft.

In the other path oil goes up to the cylinder head and lubricates valves and camshafts, etc., after passing through the internal oilway of camshafts.

An oil relief valve is provided on the oil pump. This valve starts relieving oil pressure when the pressure exceeds specified pressure.

## 1F-8 Engine Cooling System:

### Cooling Water Pipes or Hoses Removal and Installation

S5JB0A1606005

#### Removal

- 1) Drain coolant referring to "Cooling System Draining: ".
- 2) To remove these pipes or hoses, loosen clamp on each hose and pull hose end off.

#### Installation

Install removed parts in reverse order of removal procedure, noting the following.

- Tighten each clamp securely.
- Refill cooling system referring to Step 7) to 17) of "Cooling System Flush and Refill: ".

### Thermostat Removal and Installation (For M16 Engine Model)

S5JB0A1606006

#### Removal

- 1) Drain coolant referring to "Cooling System Draining: ".
- 2) Remove intake manifold referring to "Intake Manifold Removal and Installation: For M16A Engine with VVT in Section 1D".
- 3) Disconnect water inlet hose (1) and heater outlet No.2 hose (2) from each pipe.
- 4) Remove thermostat case (3) with thermostat cap (4).

- 5) Remove thermostat cap (4) from thermostat case (3).
- 6) Remove thermostat from thermostat case (3).

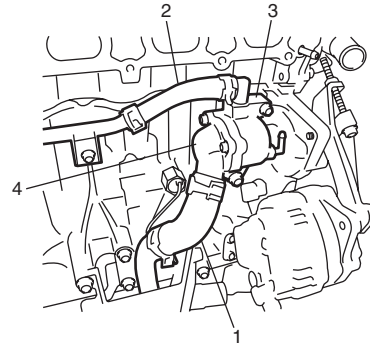

I5JB0A161008-02

#### Installation

Reverse removal procedure for installation noting the following points.

- When positioning thermostat (1) on thermostat case (2), be sure to position it so that air bleed valve (3) comes at position as shown in the figure.

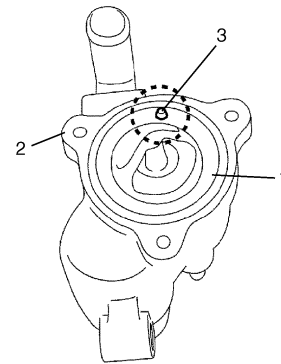

I2RH0B160006-01

- Use new O-rings when installing.
- Refill cooling system referring to Step 7) to 17) of "Cooling System Flush and Refill: ".
- Verify that there is no coolant leakage at each connection.

## Fuel Lines On-Vehicle Inspection

S5JB0A1706004

### ⚠ CAUTION

Due to the fact that fuel feed line (1) is under high pressure, use special care when servicing it.

Visually inspect fuel lines for evidence of fuel leakage, hose crack and deterioration or damage. Make sure all clamps are secure. Replace parts as needed.

## Fuel Pipe Removal and Installation

S5JB0A1706005

### ⚠ WARNING

Before starting the following procedure, be sure to observe "Precautions on Fuel System Service:" in order to reduce the risk of fire and personal injury.

### Removal

- 1) Relieve fuel pressure in fuel feed line according to "Fuel Pressure Relief Procedure:".
- 2) Disconnect negative cable at battery.
- 3) Disconnect fuel pipe joint and fuel hose (3) from fuel pipe (2) at the front and rear of each fuel pipe referring to "Fuel Hose Disconnecting and Reconnecting:".
- 4) Mark the location of clamps (1) on fuel pipes (2), so that the clamps can be reinstalled to where they were.
- 5) Remove pipes (2) with clamp (1) from vehicle.
- 6) Remove clamp (1) from pipes (2).

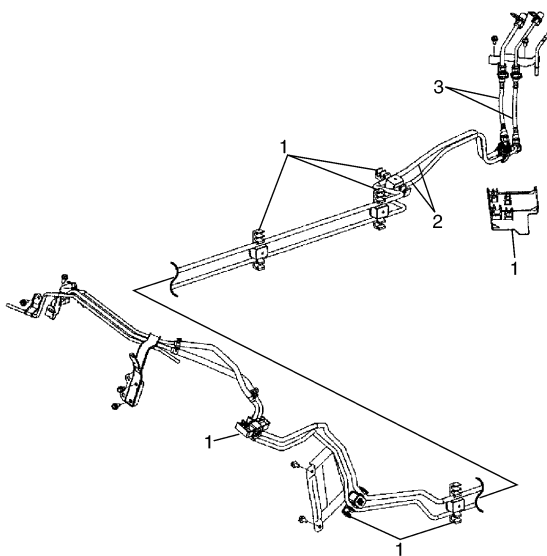

I5JB0A170006-03

## Installation

- 1) Install clamps to marked®® location on pipes. If clamp is deformed, its claw is bent or broken, replace it with new one.
- 2) Install pipes with pipe clamps to vehicle.

### NOTE

For M16 engine model, be sure to tighten fuel pipe bolt as specified tightening order described in "Fuel System Components:".

- 3) Connect fuel hoses and pipes to each pipe referring to "Fuel Hose Disconnecting and Reconnecting:".
- 4) Connect negative cable at battery.
- 5) With engine OFF, turn ignition switch to ON position and check for fuel leaks.

## Fuel Injector On-Vehicle Inspection

S5JB0A1706006

- 1) Using sound scope (1) or such, check operating sound of injector (2) when engine is running or cranking. Cycle of operating sound should vary according to engine speed. If no sound or an unusual sound is heard, check injector circuit (wire or coupler) or injector.

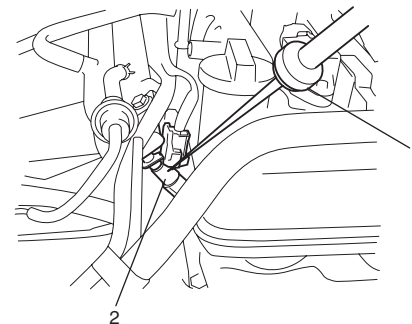

I5JB0A171007-01

- 2) Disconnect connector (1) from injector, connect ohmmeter between terminals of injector and check resistance.

### Reference resistance of fuel injector

12 Ω at 20 °C, 68 °F

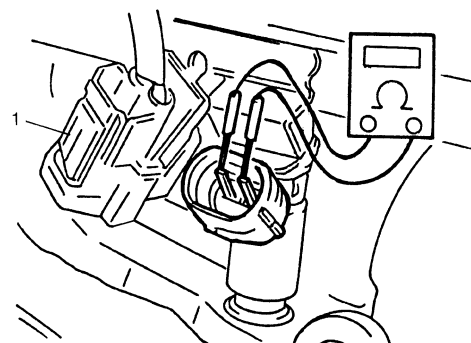

I2RH0B170008-01

- 3) Connect connector to injector securely.

## 1H-5 Ignition System:

Step	Action	Yes	No
3	<p><b>DTC check</b></p> <p>1) Perform DTC check referring to “DTC Check: in Section 1A”.</p> <p><i>Is DTC stored in ECM?</i></p>	Go to applicable DTC diag. flow.	Go to Step 4.
4	<p><b>Electrical connection check</b></p> <p>1) Check ignition coil assemblies and high-tension cords (for M16 engine) for electrical connection.</p> <p><i>Are they connected securely?</i></p>	Go to Step 5 for M16 engine or go to Step 6 for J20 engine.	Connect securely.
5	<p><b>High-tension cords check (for M16 engine)</b></p> <p>1) Check high-tension cord for resistance referring to “High-Tension Cord Inspection (For M16 Engine): ”.</p> <p><i>Is check result satisfactory?</i></p>	Go to Step 6.	Replace high-tension cord(s).
6	<p><b>Ignition coil assembly power supply and ground circuit check</b></p> <p>1) Check ignition coil assembly power supply and ground circuits for open and short.</p> <p><i>Are circuits in good condition?</i></p>	Go to Step 7.	Repair or replace.
7	<p><b>Ignition coil assembly check</b></p> <p>1) Check ignition coil for resistance referring to “Ignition Coil Assembly (Including ignitor) Inspection: ”.</p> <p><i>Is check result satisfactory?</i></p>	Go to Step 8.	Replace ignition coil assembly.
8	<p><b>CKP sensor check</b></p> <p>1) Check CKP sensor referring to “Crankshaft Position (CKP) Sensor Inspection: in Section 1C”.</p> <p><i>Is check result satisfactory?</i></p>	Go to Step 9.	Tighten CKP sensor bolt, replace CKP sensor or CKP sensor plate.
9	<p><b>CMP sensor check</b></p> <p>1) Check CMP sensor referring to “Camshaft Position (CMP) Sensor Inspection: in Section 1C”.</p> <p><i>Is check result satisfactory?</i></p>	Go to Step 10.	Tighten CMP sensor bolt, replace CMP sensor or intake camshaft.
10	<p><b>Ignition trigger signal circuit check</b></p> <p>1) Check ignition trigger signal wire for open, short and poor connection.</p> <p><i>Is circuit in good condition?</i></p>	Go to Step 11.	Repair or replace.
11	<p><b>A known-good ignition coil assembly substitution</b></p> <p>1) Substitute a known-good ignition coil assembly and then repeat Step 2.</p> <p><i>Is check result of Step 2 satisfactory?</i></p>	Go to Step 12.	Substitute a known-good ECM and then repeat Step 2.
12	<p><b>Ignition timing check</b></p> <p>1) Check initial ignition timing and ignition timing advance referring to “Ignition Timing Inspection: ”.</p> <p><i>Is check result satisfactory?</i></p>	System is in good condition.	Go to Step 13.

# Charging System

## General Description

### Battery Description

S5JB0A1A01001

The battery has three major functions in the electrical system.

- It is a source of electrical energy for cranking the engine.
- It acts as a voltage stabilizer for the electrical system.
- It can, for a limited time, provide energy when the electrical load exceeds the output of the generator.

### Carrier and Hold-Down

The battery carrier should be in good condition so that it will support the battery securely and keep it level.

Before installing the battery, the battery carrier and hold-down clamp should be clean and free from corrosion and make certain there are no parts in carrier.

To prevent the battery from shaking in its carrier, the hold-down bolts should be tight enough but not over-tightened.

### Electrolyte Freezing

The freezing point of electrolyte depends on its specific gravity. Since freezing may ruin a battery, it should be protected against freezing by keeping it in a fully charged condition. If a battery is frozen accidentally, it should not be charged until it is warmed.

### Sulfation

If the battery is allowed to stand for a long period in discharged condition, the lead sulfate becomes converted into a hard, crystalline substance, which will not easily turn back to the active material again during the subsequent recharging. "Sulfation" means the result as well as the process of that reaction.

Such a battery can be revived by very slow charging and may be restored to usable condition but its capacity is lower than before.

### Built-in Indicator (if equipped)

The battery has a built-in temperature compensated indicator (1) in the top of the battery. This indicator is to be used with the following diagnostic procedure.

When checking the indicator, make sure that the battery has a clean top. A light may be needed in some poorly-lit areas.

Three types of indication available under normal operation are as follows.

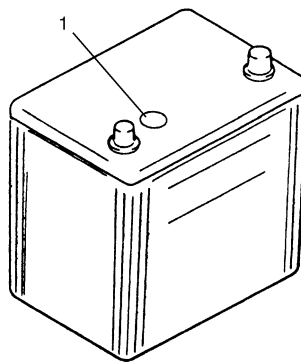

IYSQ011A0001-01

# 1K-2 Exhaust System:

## For M16 Engine Model

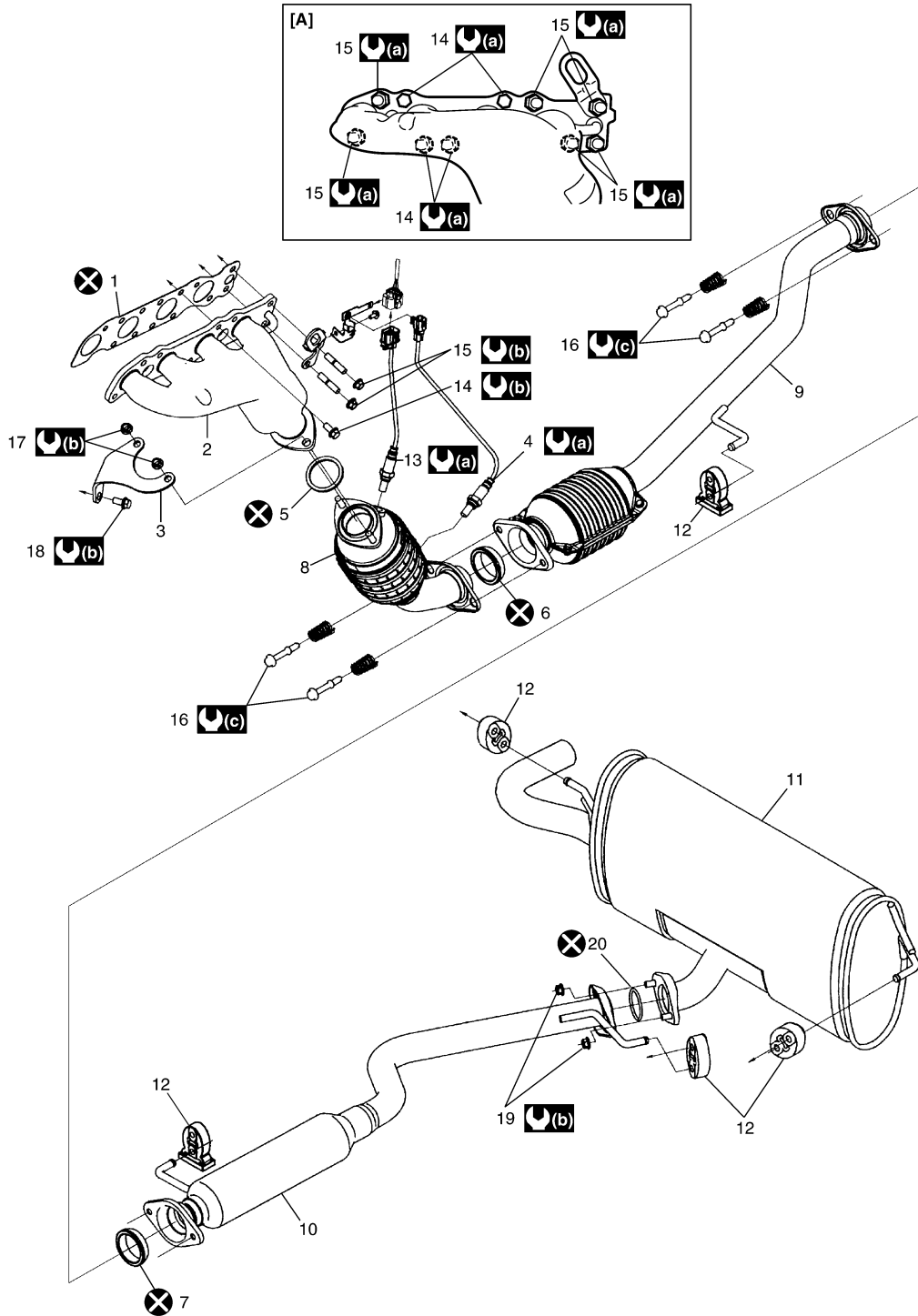

I5JB0A1B1002-03

[A]: Installing location of exhaust manifold bolt and nut.	9. Exhaust pipe No.2	18. Exhaust pipe No.1 bracket bolt
1. Exhaust manifold gasket	10. Exhaust center pipe	19. Exhaust center pipe nut
2. Exhaust manifold	11. Muffler	20. Exhaust center pipe gasket
3. Exhaust pipe No.1 bracket	12. Mounting	(a) : 45 N·m (4.5 kgf·m, 32.5 lb-ft)
4. HO2S	13. A/F sensor	(b) : 50 N·m (5.0 kgf·m, 36.5 lb-ft)
5. Exhaust pipe No.1 gasket	14. Exhaust manifold bolt	(c) : 43 N·m (4.3 kgf·m, 31.0 lb-ft)
6. No.1 seal ring	15. Exhaust manifold nut	(X) : Do not reuse.
7. No.2 seal ring	16. Exhaust pipe bolt	
8. Exhaust pipe No.1	17. Exhaust pipe No.1 bracket nut	

## Front Strut Assembly Disassembly and Assembly

S5JB0A2206004

### Disassembly

- 1) Attach special tool (A) to coil spring as shown. Turn special tool bolts alternately until coil spring tension is released. Rotate the strut around its axis to confirm that the coil spring is released or not.

#### Special tool

(A): 09943-25010

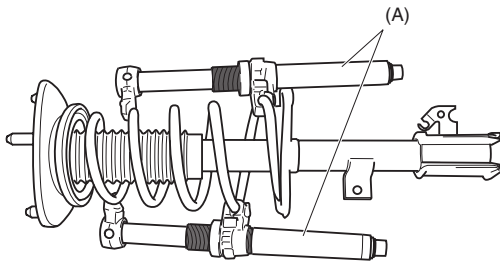

I5JB0A220059-01

### ⚠ WARNING

**Use a regular coil spring compressor and follow the operation procedure described in the Instruction Manual.**

- 2) While keeping coil spring compressed, remove strut nut with special tools as shown.

#### Special tool

(A): 09900-00411

(B): 09900-00414

(C): 09941-56510

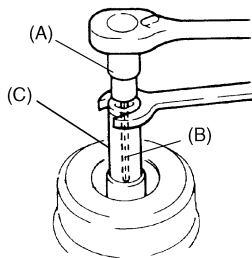

I5JB0A220060-01

- 3) Disassemble strut assembly.

### Assembly

For assembly, reverse disassembly procedure, noting the following instructions.

- 1) Compress coil spring with special tool (A) until total length becomes about 310 mm (12.2 in.) as shown.

#### Length

"a": 310 mm (12.2 in.)

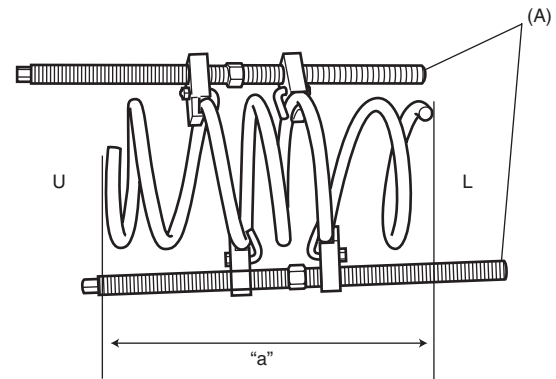

I5JB0A220010-01

U: Upper side (small dia.)
L: Lower side (large dia.)

- 2) Install bump stopper onto strut rod. For installing direction, refer to the figure in "Front Strut Assembly Components: ".
- 3) Install compressed coil spring to strut, and place coil spring end (2) onto spring lower seat (1) as shown.

### NOTE

**End of coil spring must not interfere with step of spring lower seat.**

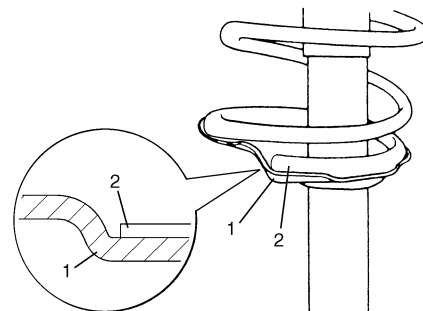

I4RS0A220011-01

## Special Tools and Equipment











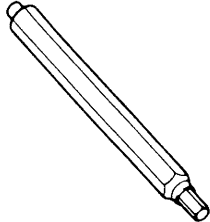

### Recommended Service Material

S5JB0A2208001

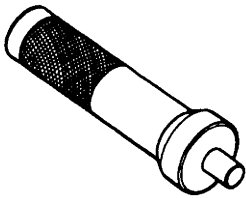
Material	SUZUKI recommended product or Specification	Note
Grease	SUZUKI Super Grease A	P/No.: 99000-25010 

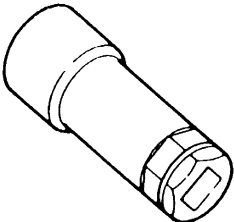
### Special Tool

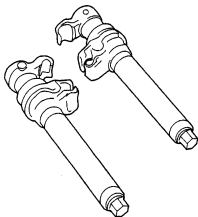
S5JB0A2208002

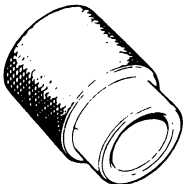
<p>09900-00411 Hexagon bit socket  / </p> 	<p>09900-00414 Hexagon bit (6 mm)  / </p> 
<p>09913-75821 Bearing installer attachment  / </p> 	<p>09941-56510 Socket wrench (19 mm)  / </p> 
<p>09943-25010 Spring compressor </p> 	<p>09945-55410 Bushing installer  / </p> 

**Assembly**

- 1) Press-fit suspension lateral link bushing (2) by using press (1) and special tool.

**⚠ CAUTION**

**Be sure to use new bushing.**

**Special tool**

**(A): 09913-85210**

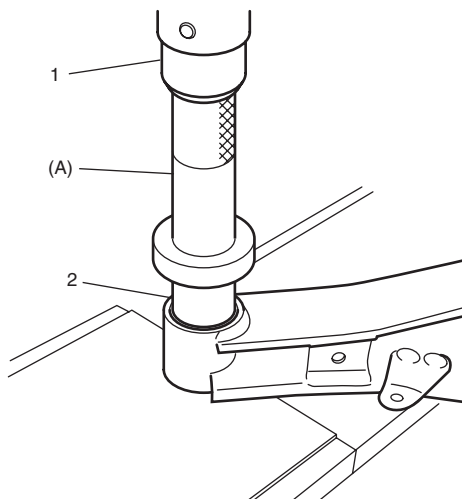

I5JB0A230083-01

- 2) Press-fit bushing (1) so that dimension "A" and "B" in figure become equal.

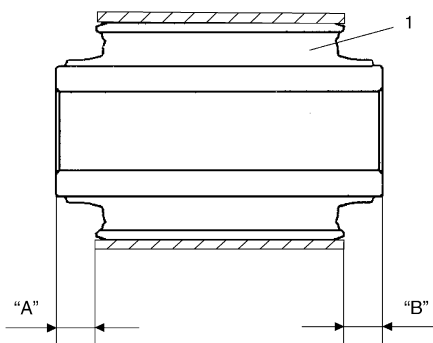

I5JB0A230037-02

**Lower Arm Check**

S5JB0A2306033

- Inspect for cracks, deformation or damage.
  - Inspect bushing for wear and breakage.
- If any faulty condition is found, replace.

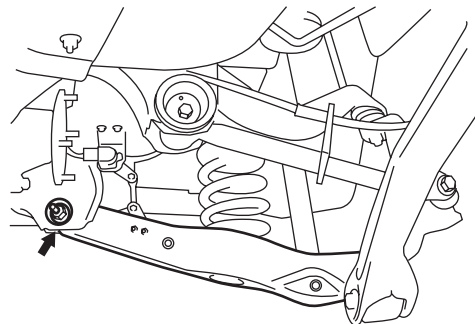

I5JB0A230038-01

**Upper Arm Removal and Installation**

S5JB0A2306034

**Removal**

- 1) Hoist vehicle and remove rear wheels.
- 2) Remove control rod refer to "Control Rod Removal and Installation: ".
- 3) Remove trailing rod refer to "Trailing Rod Removal and Installation: ".
- 4) Remove lower arm refer to "Lower Arm Removal and Installation: ".
- 5) Remove rear suspension knuckle refer to "Rear Suspension knuckle Removal and Installation: ".
- 6) Remove wheel sensor bolts (1) from upper arm (2).

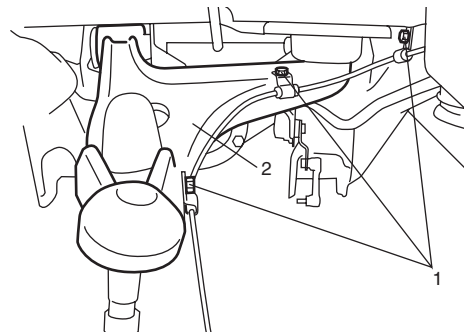

I5JB0A230039-01

- 7) Remove upper arm bolts (1) and then upper arm (2).

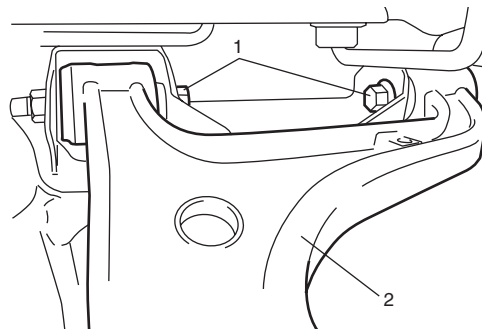

I5JB0A230040-01

# Wheels and Tires

## General Description

### Tires Description

S5JB0A2401001

The tire is of tubeless type. The tire is designed to operate satisfactorily with loads up to the full rated load capacity when inflated to the recommended inflation pressures.

Correct tire pressures and driving habits have an important influence on tire life. Heavy cornering, excessively rapid acceleration, and unnecessary sharp braking increase tire wear.

### Tire Placard

The "Tire Placard" is located on the left or right door lock pillar and should be referred to tire information.

The placard lists the maximum load, tire size and cold tire pressure where applicable.

### NOTE

**Whether rim size and/or maximum load are listed or not depends on regulations of each country.**

### Inflation of Tires

The pressure recommended for any model is carefully calculated to give a satisfactory ride, stability, steering, tread wear, tire life and resistance to bruises.

Tire pressure, with tires cold, (after vehicle has set for 3 hours or more, or driven less than one mile) should be checked monthly or before any extended trip. Set to the specifications on the "Tire Placard" located on the left or right door lock pillar.

It is normal for tire pressure to increase when the tires become hot during driving.

Do not bleed or reduce tire pressure after driving.

Bleeding reduces the "Cold Inflation Pressure".

### Higher than recommended pressure can cause:

- Hard ride
- Tire bruising or carcass damage
- Rapid tread wear at center of tire

### Unequal pressure on same axle can cause:

- Uneven braking
- Steering lead
- Reduced handling
- Swerve on acceleration

### Lower than recommended pressure can cause:

- Tire squeal on turns
- Hard Steering
- Rapid and uneven wear on the edges of the tread
- Tire rim bruises and rupture
- Tire cord breakage

- High tire temperature
- Reduced handling
- High fuel consumption

### Matched Tires and Wheels (Steel Type)

Tires and wheels are match mounted at the assembly plant.

This means that the radially stiffest part of the tire, or "high spot", is matched to the smallest radius or "low spot" of the wheel.

This is done to provide the smoothest possible ride.

The "high spot" of the tire is originally marked by paint dot (1) on the outboard sidewall. This paint dot will eventually wash off the tire.

The "low spot" of the wheel is originally marked by paint dot (2) on the wheel rim-flange. Properly assembled, the wheel rims' paint dot should be aligned with the tires' paint dot as shown in figure.

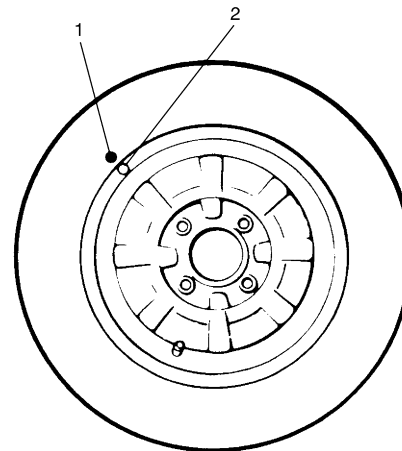

I2RH01240001-01

Whenever a tire is dismounted from its wheel, it should be remounted so that the tire and wheel are matched. If the tire's paint dot cannot be located, a line should be scribed on the tire and wheel before dismounting to assure that it is remounted in the same position.

### Replacement Tires

When replacement is necessary, the original equipment type tire should be used. Refer to the "Tire Placard". Replacement tires should be of the same size, load range and construction as those originally on the vehicle. Use of any other size or type tire may affect ride, handling, speedometer / odometer calibration, vehicle ground clearance and tire or snow chain clearance to the body and chassis.

It is recommended that new tires be installed in pairs on the same axle. If necessary to replace only one tire, it should be paired with the tire having the most tread, to equalize braking traction.

# Rear

## General Description

### Rear Drive Shaft Construction

S5JB0A3121002

Refer to "Front Drive Shaft Construction: Front".

## Repair Instructions

### Rear Drive Shaft Components



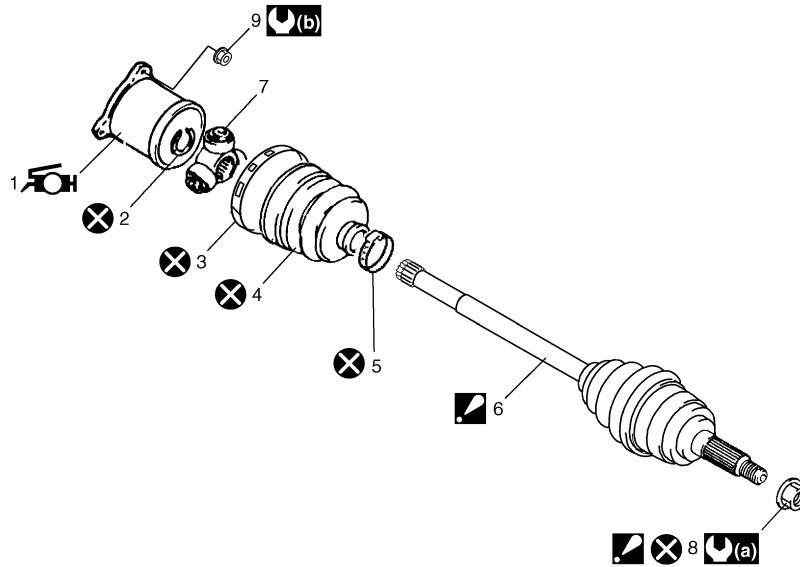

S5JB0A3126007

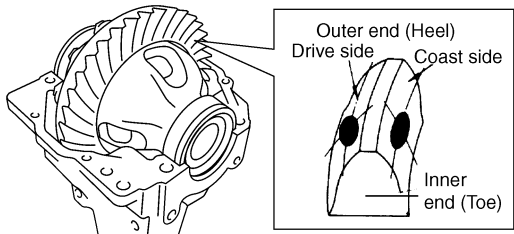

I5JB0A312001-02

<b>1.</b> Differential side joint (Constant velocity tripod joint) : Apply yellow grease included in spare part to joint.	<b>5.</b> Boot band (Small)	<b>9.</b> Rear drive shaft flange nut
<b>2.</b> Snap ring	<b>6.</b> Wheel side joint (Constant velocity ball joint) : Never disassemble.	<b>(a)</b> : 200 N·m (20.0 kgf·m, 145.0 lb-ft)
<b>3.</b> Boot band (Large)	<b>7.</b> Tripod joint spider	<b>(b)</b> : 80 N·m (8.0 kgf·m, 58.0 lb-ft)
<b>4.</b> Boot (Differential side)	<b>8.</b> Drive shaft nut : After tightening nut, caulk nut securely.	: Do not reuse.

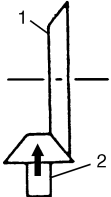
3B-15 Differential: Front

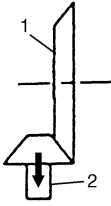
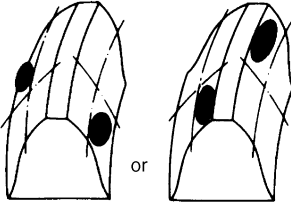
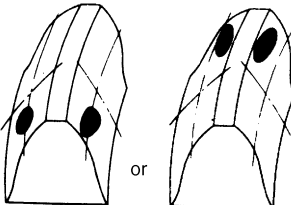
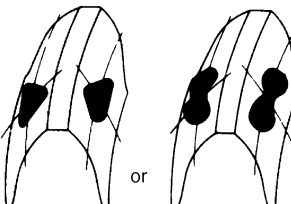
Tooth Contact Pattern	Diagnosis and Remedy	
 <p>I5JB0A321041-05</p>	<p>Normal</p>	
 <p>IYSQ01321072-01</p>	<p><b>High Contact</b> Pinion is positioned too far from the center of drive bevel gear (1).</p> <ul style="list-style-type: none"> <li>• Increase thickness of pinion (2) height adjusting shim and position pinion closer to gear center.</li> <li>• Adjust drive bevel gear backlash to specification.</li> </ul>	 <p>IYSQ01321073-01</p>
 <p>IYSQ01321074-01</p>	<p><b>Low Contact</b> Pinion is positioned too close to the center of drive bevel gear (1).</p> <ul style="list-style-type: none"> <li>• Decrease thickness of pinion (2) height adjusting shim and position pinion farther from gear center.</li> <li>• Adjust drive bevel gear backlash to specification.</li> </ul>	 <p>IYSQ01321076-01</p>
 <p>IYSQ01321077-01</p>	<p>If adjustment is impossible, replace differential carrier.</p>	
 <p>IYSQ01321078-01</p>	<ul style="list-style-type: none"> <li>• Check seating of bevel gear or differential case. (Check bevel gear for runout.)</li> <li>• If adjustment is impossible, replace drive bevel gear and pinion set or differential carrier.</li> </ul>	
 <p>IYSQ01321079-01</p>	<p>Replace drive bevel gear and pinion set or differential case.</p>	

- 17) While tightening flange nut gradually with special tool and power wrench (4 – 10 magnification) (1), set preload of pinion to specification.

**NOTE**

- Before taking measurement with spring balance (3) or torque wrench (4), check for smooth rotation by hand.
- On measuring preload, rotate the drive bevel pinion about 1 rotation per 2 seconds.
- Be sure to tighten gradually and carefully till specified starting torque is obtained. Turning back overtightened flange nuts should be avoided.

**Pinion bearing preload**

0.9 – 1.7 N·m (9.0 – 17.0 kg·cm, 7.8 – 14.7 lb·in.)

**Spring measure reading with special tool**

20 – 40 N (2.0 – 4.0 kg, 4.4 – 8.8 lb)

**Special tool**

(A): 09922-75222

(B): 09922-66021

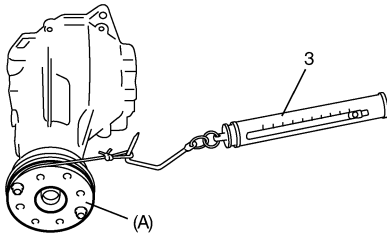
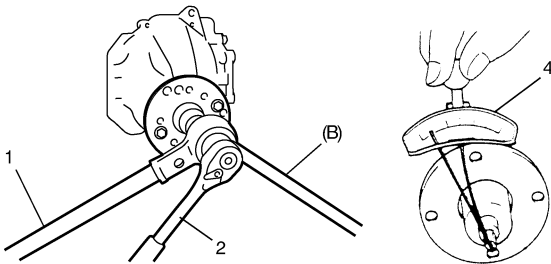

I5JB0A321036-02

2. Socket wrench

- 18) Select differential side bearing shim as follows.

- a) Measure dimension “a” and “b” using vernier caliper.

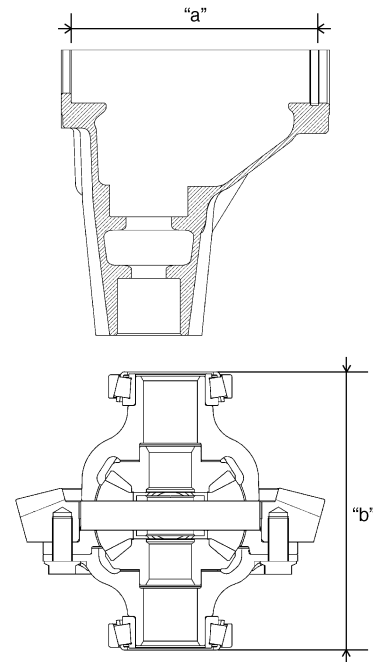

I5JB0A321037-04

- b) Calculate dimension “a” – “b”, and select shims from among following available size so that total of thickness of right side and left side shims may reach the calculated value.

**NOTE**

Select shims so that thickness of right side shims and left side shims become almost even.

**Available shim thickness**

Right side: 1.75, 1.85, 1.95, 2.00, 2.05, 2.15 and 2.25 mm (0.069, 0.073, 0.077, 0.079, 0.081, 0.085 and 0.089 in.)

Left side: 2.75, 2.85, 2.95, 3.00, 3.05, 3.15 and 3.25 mm (0.108, 0.112, 0.116, 0.118, 0.120, 0.124 and 0.128 in.)

### 3C-10 Transfer: Motor-Shift Type (Transfer with Shift Actuator)

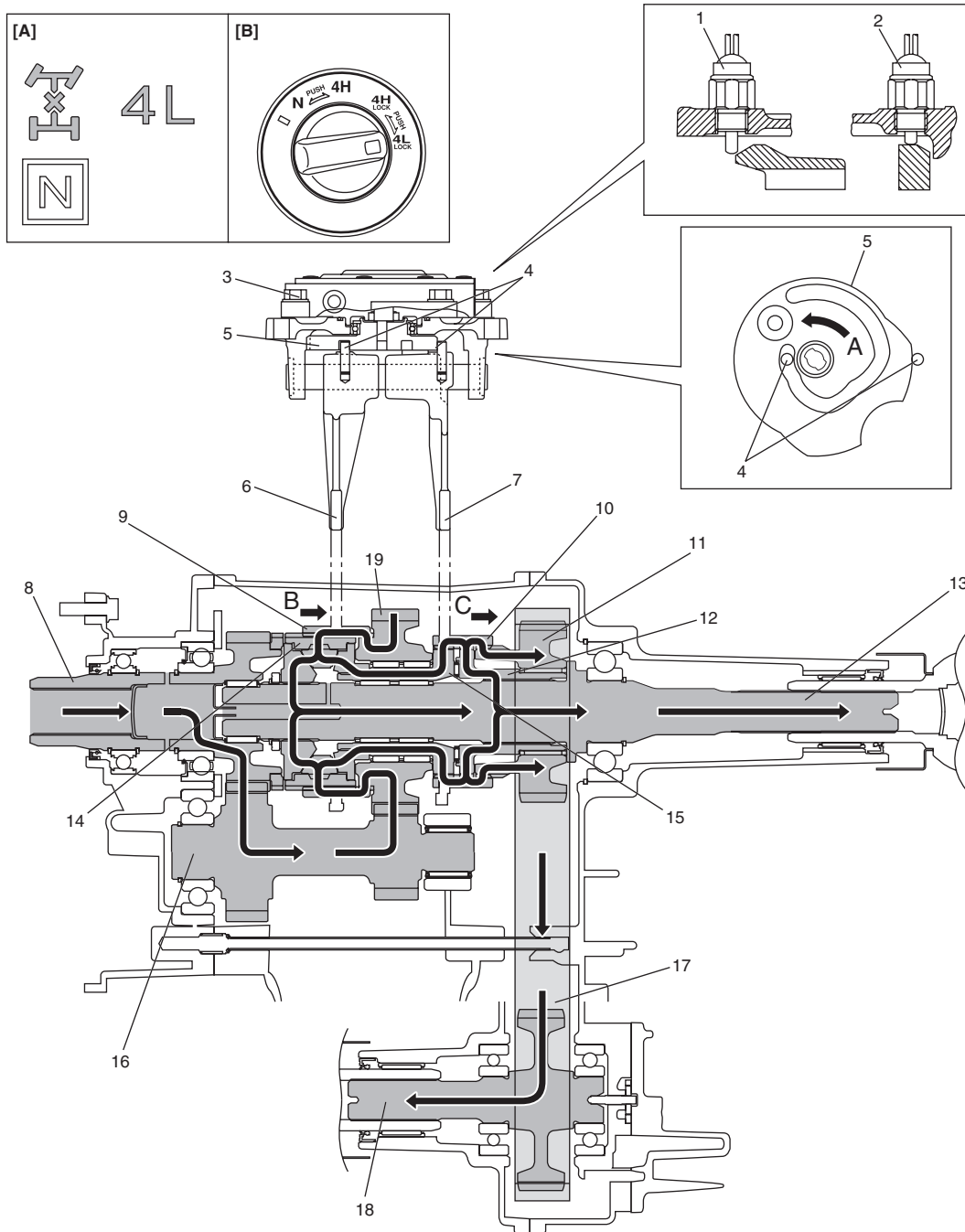

I5JB0A332006-02

[A]: Transfer position indicator	6. High / Low shift fork	13. Rear output shaft
[B]: Transfer switch	7. Differential lock shift fork	14. Center LSD case
1. 4L/N switch	8. Input gear	15. Front drive shaft
2. Center differential lock switch	9. Reduction shift sleeve	16. Counter gear
3. Transfer actuator	10. Differential lock clutch sleeve	17. Drive chain
4. Shift fork pin	11. Front drive sprocket	18. Front output shaft
5. Shift cam	12. Front drive sprocket bush	19. Low gear

DTC C1213: Transfer Switch Circuit Open

S5JB0A3314041

Wiring Diagram

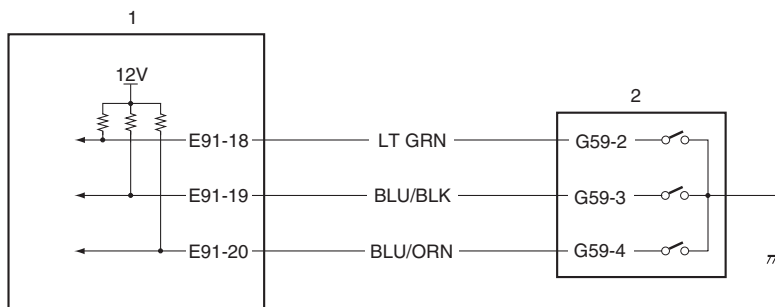

[A]

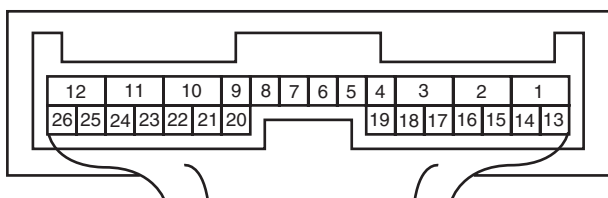

[B]

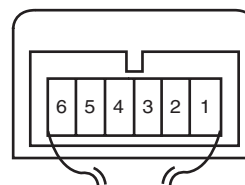

I5JB0A332016-01

[A]: 4WD control module connector "E91" (viewed from harness side)	1. 4WD control module
[B]: Transfer switch connector "G59" (viewed from harness side)	2. Transfer switch

DTC Detecting Condition and Trouble Area

DTC detecting condition	Trouble area
Transfer switch combination different from specification is detected for more than 0.5 seconds.	<ul style="list-style-type: none"> <li>Transfer switch</li> <li>Transfer switch circuit</li> <li>4WD control module</li> </ul>

DTC Confirmation Procedure

- 1) Clear DTC using scan tool.
- 2) Select transfer switch to "4H" position and keep its position for 10 seconds. Similarly select transfer switch to "4H-lock", "N" and "4L-lock" position.
- 3) Check DTC.

Troubleshooting

Step	Action	Yes	No
1	Was "4WD control system check" performed?	Go to Step 2.	Go to "4WD Control System Check: Motor-Shift Type (Transfer with Shift Actuator)".
2	<p><b>Transfer switch circuit check</b></p> <ol style="list-style-type: none"> <li>1) Disconnect transfer switch connector "G59" with ignition switch OFF.</li> <li>2) Check for proper connection to "G59-2", "G59-3" and "G59-4" terminals of transfer switch connector.</li> <li>3) If connection is OK, measure voltage between "G59-2", "G59-3" or "G59-4" terminal of transfer switch connector and vehicle body ground with ignition switch ON.</li> </ol> <p>Is it 10 – 14 V?</p>	Go to Step 3.	Go to Step 4.

### 3C-44 Transfer: Motor-Shift Type (Transfer with Shift Actuator)

Step	Action	Yes	No
4	<p><b>Wire harness check</b></p> <p>1) Disconnect connector from 4WD control module connector "E91" with ignition switch OFF.</p> <p>2) Check for proper connection to "E91-7" terminal of 4WD control module connector.</p> <p>3) If OK, measure resistance between "BLK/ORN" terminal of CPP switch connector and "E91-7" terminal of 4WD control module connector.</p> <p><i>Is it 1 MΩ or more?</i></p>	Substitute a known-good 4WD control module and recheck.	"BLK/ORN" wire is shorted to ground circuit.

### DTC U1073: Control Module Communication Buss Off

S5JB0A3314052

#### Wiring Diagram

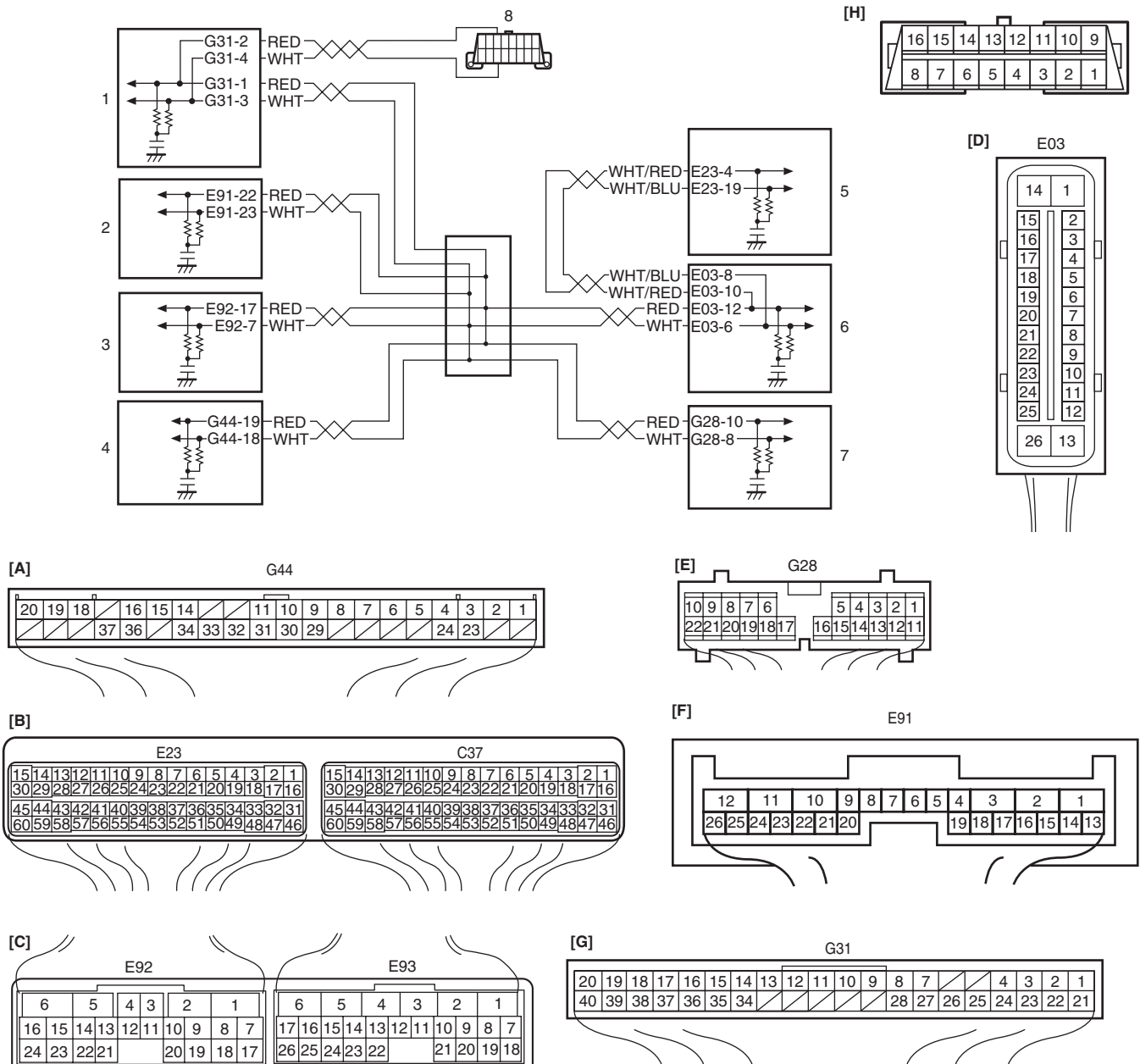

I5JB0A332021-01

- 12) Remove needle bearings (1), front drive shaft (2) and thrust needle bearing (4) from rear output shaft (3).

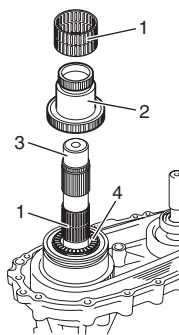

I5JB0A331021-01

- 13) Remove differential lock clutch sleeve (1) from rear output shaft (2).

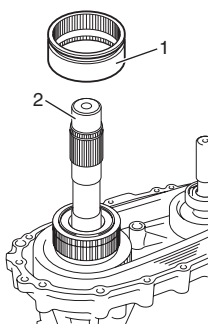

I5JB0A331022-01

- 14) Remove front drive sprocket bush (1) from rear output shaft (2).

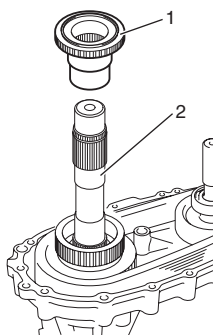

I5JB0A331023-01

- 15) Take out front drive sprocket (1), front output shaft assembly (2), drive chain (3) and needle bearing (4) from rear case (5) all at once.

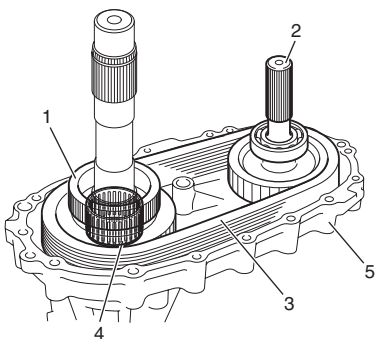

I5JB0A331024-01

- 16) Remove snap ring (1), and then remove rear output shaft assembly (2) from rear case (3).

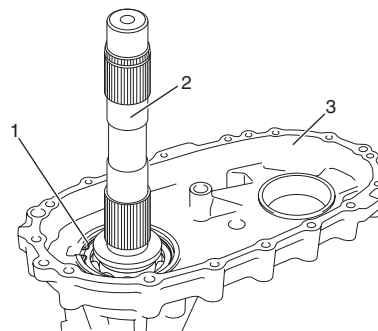

I5JB0A331025-01

- 17) Remove rear oil seal (1) from rear case (2) using flat end rod or the like, if necessary.

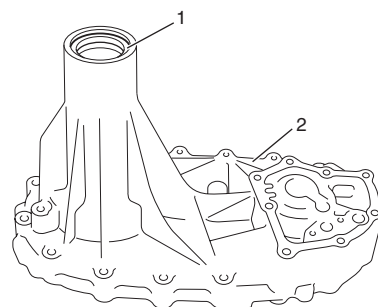

I5JB0A331026-01

- 18) Remove needle bearing (1) from rear case (2) using special tool, if necessary.

**Special tool**  
**(A): 09913-76010**

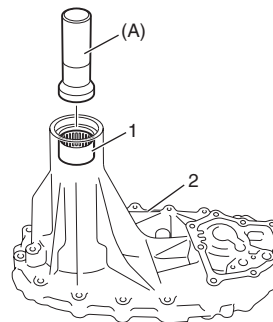

I5JB0A331027-01

- 19) Remove input gear plate bolts (1) from front case (2).

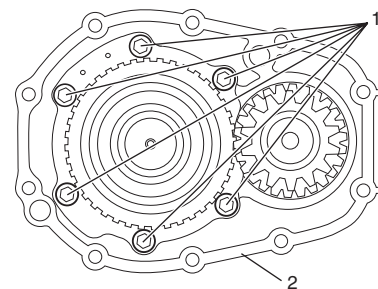

I5JB0A331028-01

# 3C-78 Transfer: Non-Shift Type (Transfer without Shift Actuator)

## Transfer Assembly Components

S5JB0A3326006

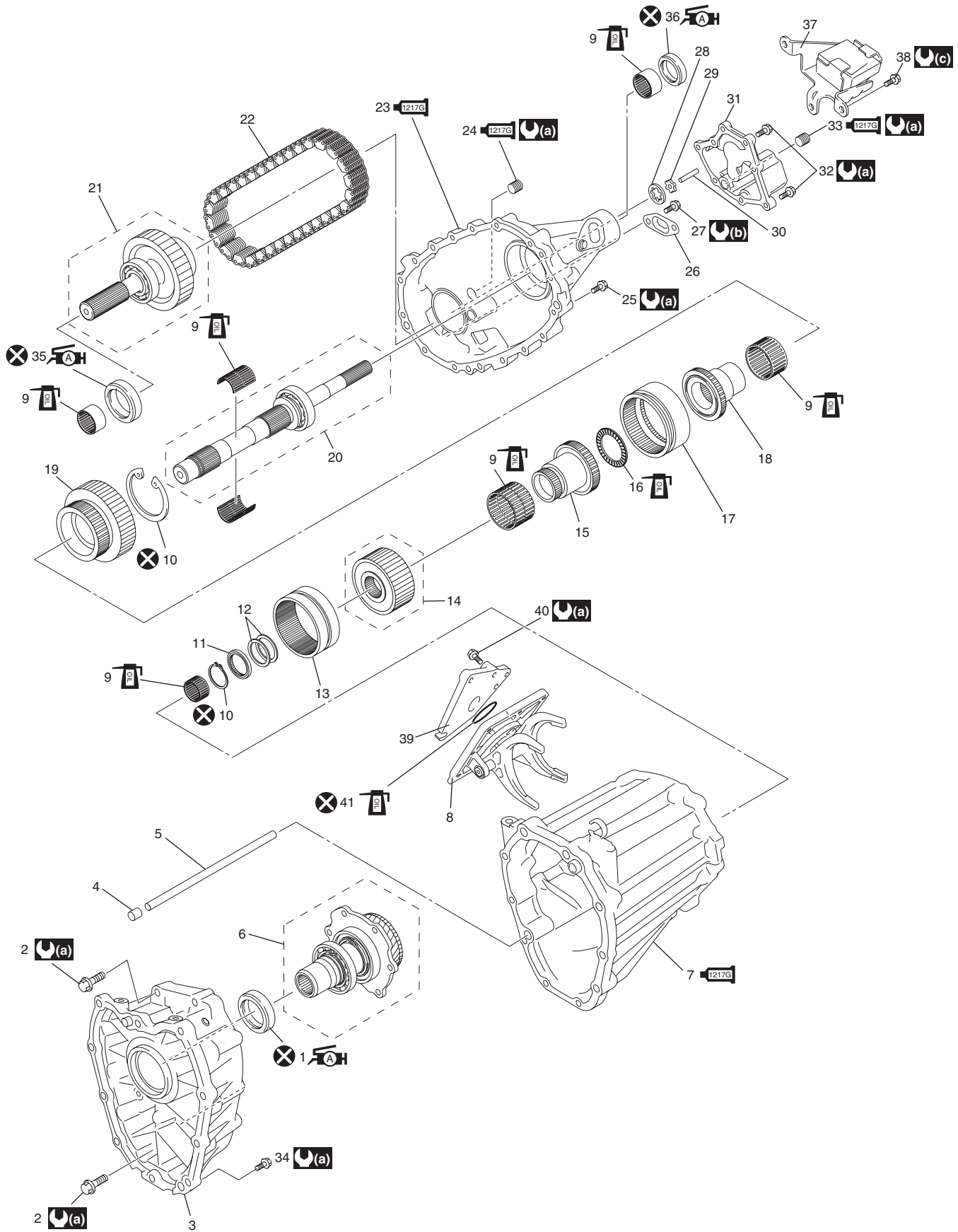

15JB0A331084-05

## Section 4

## Brakes

## CONTENTS

<b>Precautions</b> .....	<b>4-1</b>	<b>General Description</b> .....	<b>4B-1</b>
<b>Precautions</b> .....	4-1	Front Disc Brake Caliper Assembly	
Precautions for Brakes.....	4-1	Construction.....	4B-1
<b>Brake Control System and Diagnosis ...</b>	<b>4A-1</b>	<b>Repair Instructions</b> .....	<b>4B-2</b>
<b>General Description</b> .....	<b>4A-1</b>	Front Disc Brake Components .....	4B-2
Brakes Construction.....	4A-1	Front Disc Brake Pad On-Vehicle Check .....	4B-3
Front Brake Hose / Pipe Construction.....	4A-2	Front Disc Brake Pad Removal and	
Rear Brake Hose / Pipe Construction .....	4A-3	Installation .....	4B-3
Master Cylinder Assembly Construction .....	4A-3	Front Brake Disc and Pad Inspection.....	4B-4
Booster Assembly Construction .....	4A-4	Front Disc Brake Caliper Removal and	
<b>Diagnostic Information and Procedures</b> .....	<b>4A-4</b>	Installation .....	4B-5
Brake Diagnosis Note .....	4A-4	Front Disc Brake Caliper Disassembly and	
Brakes Symptom Diagnosis .....	4A-5	Assembly.....	4B-6
<b>Repair Instructions</b> .....	<b>4A-7</b>	Front Disc Brake Caliper Inspection.....	4B-7
Excessive Pedal Travel Check.....	4A-7	Front Brake Disc Removal and Installation .....	4B-8
Brake Pedal Play Check .....	4A-7	Front Brake Disc Inspection .....	4B-8
Brake Fluid Level Check .....	4A-7	<b>Specifications</b> .....	<b>4B-9</b>
Air Bleeding of Brake System .....	4A-8	Tightening Torque Specifications.....	4B-9
Brake Pedal Free Height Adjustment.....	4A-9	<b>Special Tools and Equipment</b> .....	<b>4B-9</b>
Brake Light Switch Adjustment .....	4A-9	Recommended Service Material .....	4B-9
Brake Flexible Hose and Pipe Check.....	4A-9	<b>Rear Brakes</b> .....	<b>4C-1</b>
Master Cylinder Check.....	4A-9	<b>General Description</b> .....	<b>4C-1</b>
Flushing Brake Hydraulic System .....	4A-10	Rear Drum Brake Assembly Construction .....	4C-1
Booster Operation Check.....	4A-10	<b>Repair Instructions</b> .....	<b>4C-2</b>
Front Brake Hose / Pipe Removal and		Rear Drum Brake Assembly Components .....	4C-2
Installation .....	4A-11	Rear Brake Drum Removal and Installation.....	4C-3
Rear Brake Hose / Pipe Removal and		Rear Brake Drum and Shoe Inspection .....	4C-4
Installation .....	4A-11	Rear Brake Shoe On-Vehicle Check.....	4C-4
Master Cylinder Components.....	4A-12	Rear Brake Shoe Removal and Installation .....	4C-5
Master Cylinder Reservoir Removal and		Rear Brake Shoe Inspection .....	4C-6
Installation .....	4A-13	Wheel Cylinder Removal and Installation .....	4C-6
Master Cylinder Assembly Removal and		Wheel Cylinder Inspection .....	4C-7
Installation .....	4A-14	Rear Brake Back Plate Removal and	
Master Cylinder Assembly Inspection .....	4A-15	Installation .....	4C-7
Brake Booster Components .....	4A-16	<b>Specifications</b> .....	<b>4C-9</b>
Brake Booster Removal and Installation .....	4A-17	Tightening Torque Specifications.....	4C-9
Booster Push Rod Clevis Adjustment .....	4A-17	<b>Special Tools and Equipment</b> .....	<b>4C-9</b>
<b>Specifications</b> .....	<b>4A-18</b>	Recommended Service Material .....	4C-9
Tightening Torque Specifications.....	4A-18	<b>Parking Brake</b> .....	<b>4D-1</b>
<b>Special Tools and Equipment</b> .....	<b>4A-18</b>	<b>Component Location</b> .....	<b>4D-1</b>
Recommended Service Material .....	4A-18	Parking Brake Cable Location.....	4D-1
Special Tool .....	4A-18	<b>Repair Instructions</b> .....	<b>4D-2</b>
<b>Front Brakes</b> .....	<b>4B-1</b>	Parking Brake Check and Adjustment .....	4D-2

## 4A-15 Brake Control System and Diagnosis:

- 3) Tighten master cylinder fixing nuts (1) to specified torque.

### Tightening torque

**Master cylinder fixing nut (a): 18 N·m (1.8 kgf-m, 13.0 lb-ft)**

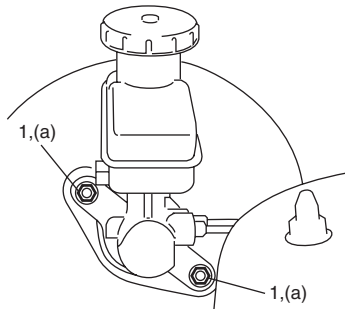

I5JB0A410021-02

- 4) Connect brake pipes to master cylinder and tighten brake pipe flare nuts (1) to specified torque.

### Tightening torque

**Brake pipe flare nut (a): 16 N·m (1.6 kgf-m, 12.0 lb-ft)**

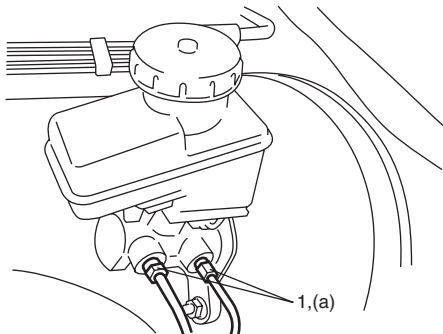

I5JB0A410020-01

- 5) Connect clutch reservoir hose (1) to reservoir (2) for M/T vehicle.

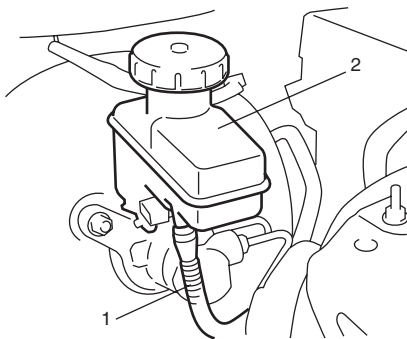

I5JB0A410012-02

- 6) Connect reservoir lead wire at coupler.  
7) Fill reservoir with specified brake fluid.  
8) After installing, bleed air from brake system referring to "Air Bleeding of Brake System:" and at the same time bleed air from clutch system referring to "Air Bleeding of Clutch System:" in Section 5C" for M/T vehicle.  
9) Perform brake test and check each installed part for fluid leakage.

## Master Cylinder Assembly Inspection

S5JB0A4106017

- Check master cylinder for corrosion and smooth operation.
- Inspect distance "a" to be the following. If measurement is out of specification, replace master cylinder assembly.

### Distance

**"a": 72.0 mm (2.83 in.) or more**

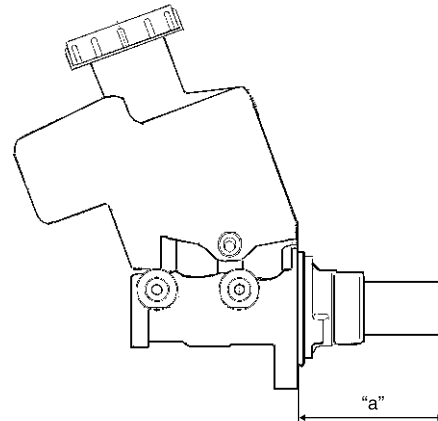

I5JB0A410022-01

## Rear Brake Shoe Removal and Installation

S5JB0A4306006

**▲ WARNING**

Use special care when installing brake shoe return spring. Failure in its proper installation may allow it to springback and cause personal injury.

**Removal**

- 1) Remove brake drum referring to "Rear Brake Drum Removal and Installation: ".
- 2) Fully turn adjuster (1) to reduce brake shoe adjuster.

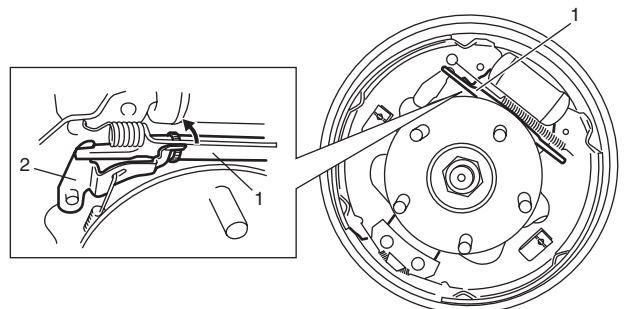

I5JB0A430019-01

2. Adjuster pawl lever

- 3) Remove shoe hold down springs (1) by turning shoe hold down pins (2).

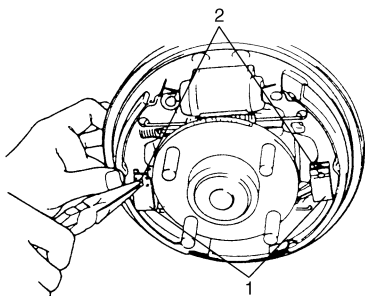

I2RH01430012-01

- 4) Remove upper shoe return spring (1), brake adjuster (2), adjuster pawl lever (3) and spring.
- 5) Remove brake shoes (4) and lower shoe return spring (5).

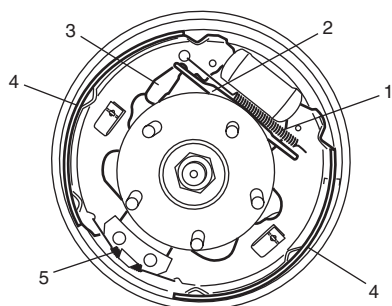

I5JB0A430006-01

- 6) Disconnect parking brake shoe lever (1) from parking brake cable (2).

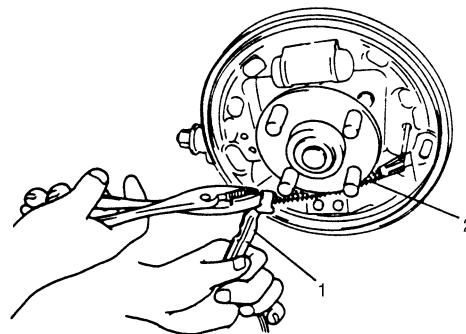

I2RH01430013-01

- 7) Remove push nut (1).
- 8) Remove parking brake shoe lever (2) from brake shoe (3).

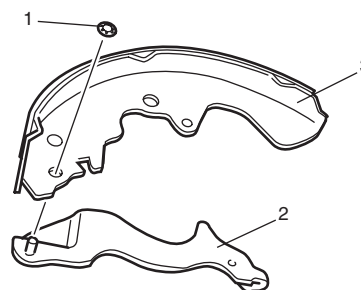

I5JB0A430007-01

**Installation**

- 1) Assemble parts in reverse order of removal procedure.
- 2) Before install brake shoe, be sure to fully turn brake adjuster to reduce.
- 3) Install shoe hold down springs (1) by pushing them down in place and turning hold down pins (2).

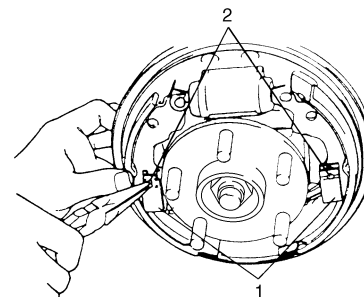

I5JB0A430010-01

## 4E-9 ABS:

### Step 3: DTC Check

Recheck DTC referring to “DTC Check: ”.

### Step 4: ABS Check

According to ABS Check for the DTC confirmation in Step 3, locate the cause of the trouble, namely in a sensor, switch, wire harness, connector, actuator assembly or other part and repair or replace faulty parts.

### Step 5: Brakes Diagnosis

Check the parts or system suspected as a possible cause referring to “Brakes Symptom Diagnosis: in Section 4A” and based on symptoms appearing on the vehicle (symptom obtained through Steps 1 and 2 and repair or replace faulty parts, if any).

### Step 6: Check for Intermittent Problem

Check parts where an intermittent trouble is easy to occur (e.g., wire harness, connector, etc.), referring to “Intermittent and Poor Connection Inspection: in Section 00” and related circuit of trouble code recorded in Step 1 to 3.

### Step 7: Final Confirmation Test

Confirm that the problem symptom has gone and the ABS is free from any abnormal conditions. If what has been repaired is related to the malfunction DTC, clear the DTC once referring to “DTC Clearance: ” and perform test driving and confirm that no DTC is indicated.

## ABS Warning Lamp Check

S5JB0A4504002

- 1) Turn ignition switch ON.
- 2) Check that ABS warning lamp (1) comes ON for about 2 seconds and then goes off.  
If any faulty condition is found, advance to “ABS Warning Lamp Does Not Come ON at Ignition Switch ON: ”, “ABS Warning Lamp Comes ON Steady: ” or “ABS Warning Lamp Flashes Continuously while Ignition Switch Is ON: ”.

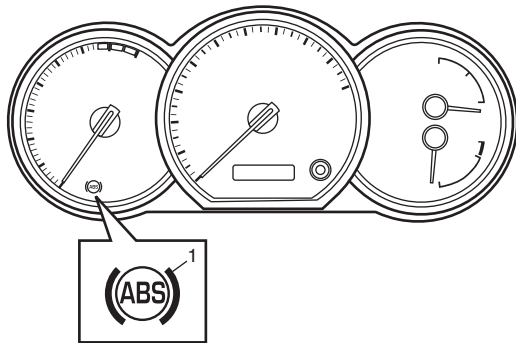

I5JB0A450001-01

## EBD Warning Lamp (Brake Warning Lamp) Check

S5JB0A4504003

### NOTE

**Perform this check on a level place.**

- 1) Turn ignition switch ON with parking brake applied.
- 2) Check that EBD warning lamp (brake warning lamp) (1) is turned ON.
- 3) Release parking brake with ignition switch ON and check that EBD warning lamp (brake warning lamp) goes off.  
If it doesn't go off, go to “EBD Warning Lamp (Brake Warning Lamp) Comes ON Steady: ”.

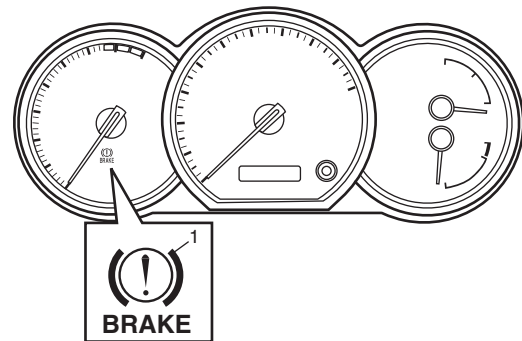

I5JB0A450007-01

## DTC Check

S5JB0A4504004

- 1) Turn ignition switch to OFF position.
- 2) Connect SUZUKI scan tool to data link connector (1).

### Special tool

(A): SUZUKI scan tool

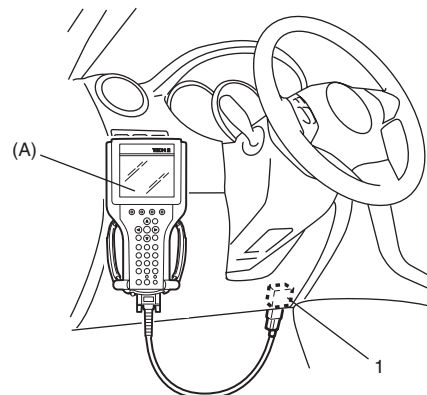

I5JB0A450008-01

CLICK HERE TO **DOWNLOAD** THE COMPLETE MANUAL

- Thank you very much for reading the preview of the manual.
- You can download the complete manual from: [www.heydownloads.com](http://www.heydownloads.com) by clicking the link below



- Please note: If there is no response to CLICKING the link, please download this PDF first and then click on it.

CLICK HERE TO **DOWNLOAD** THE COMPLETE MANUAL

### DTC C1071: ABS Control Module

S5JB0A4504018

#### Wiring Diagram

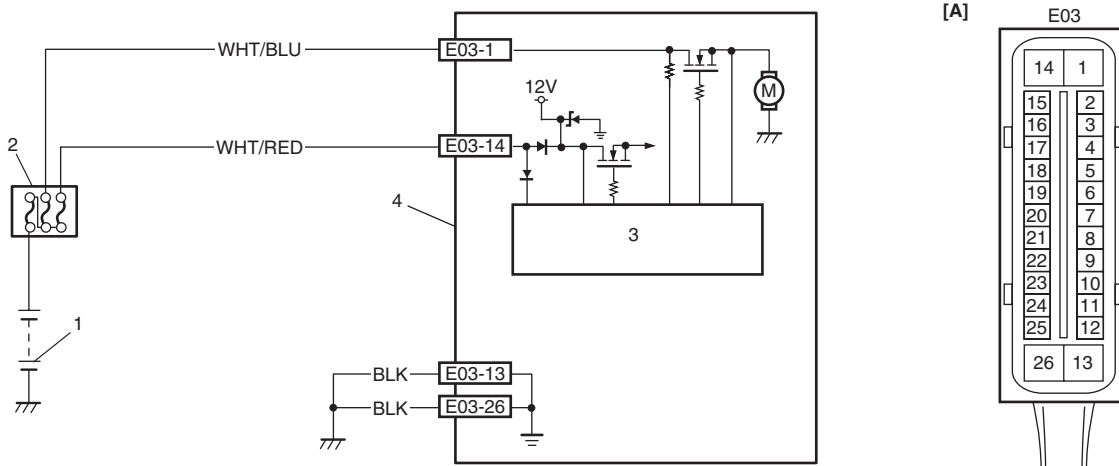

I5JB0A450019-02

[A]: ABS hydraulic unit / control module connector (viewed from terminal side)	2. Main fuse box	4. ABS hydraulic unit / control module assembly
1. Battery	3. ABS power control module	

#### DTC Detecting Condition

This DTC will be set when an internal malfunction is detected in the ABS control module.

#### DTC Troubleshooting

Step	Action	Yes	No
1	Was "ABS Check" performed?	Go to Step 2.	Go to "ABS Check: "
2	Clear all DTCs and check DTC.  Is it DTC C1071?	Go to Step 3.	Could be a temporary malfunction of the ABS control module.
3	1) Check for proper connection of ABS hydraulic unit / control module connector. 2) If OK, disconnect ABS hydraulic unit / control module connector and check the following. <ul style="list-style-type: none"> <li>• Voltage "E03-1" terminal: 10 – 14 V</li> <li>• Voltage "E03-14" terminal: 10 – 14 V</li> <li>• Resistance between "E03-13" and body ground: Continuity</li> <li>• Resistance between "E03-26" and body ground: Continuity</li> </ul> Are the check result as specified?	Replace ABS hydraulic unit / control module assembly.	Repair "WHT/RED", "WHT/BLU" and/or "BLK" circuit and recheck.

# Precautions

## Precautions

### Precautions for Transmission / Transaxle

S5JB0A5000001

#### Air Bag Warning

Refer to "Air Bag Warning: in Section 00".

#### Fastener Caution

Refer to "Fastener Caution: in Section 00".

#### Precautions in Diagnosing Trouble (for A/T)

Refer to "Precautions in Diagnosing Trouble: in Section 5A".

#### Precautions for Disassembly and Reassembly (for A/T)

Refer to "Precautions for Disassembly and Reassembly: in Section 5A".

# Component Location

## Electronic Shift Control System Components Location

S5JB0A5103001

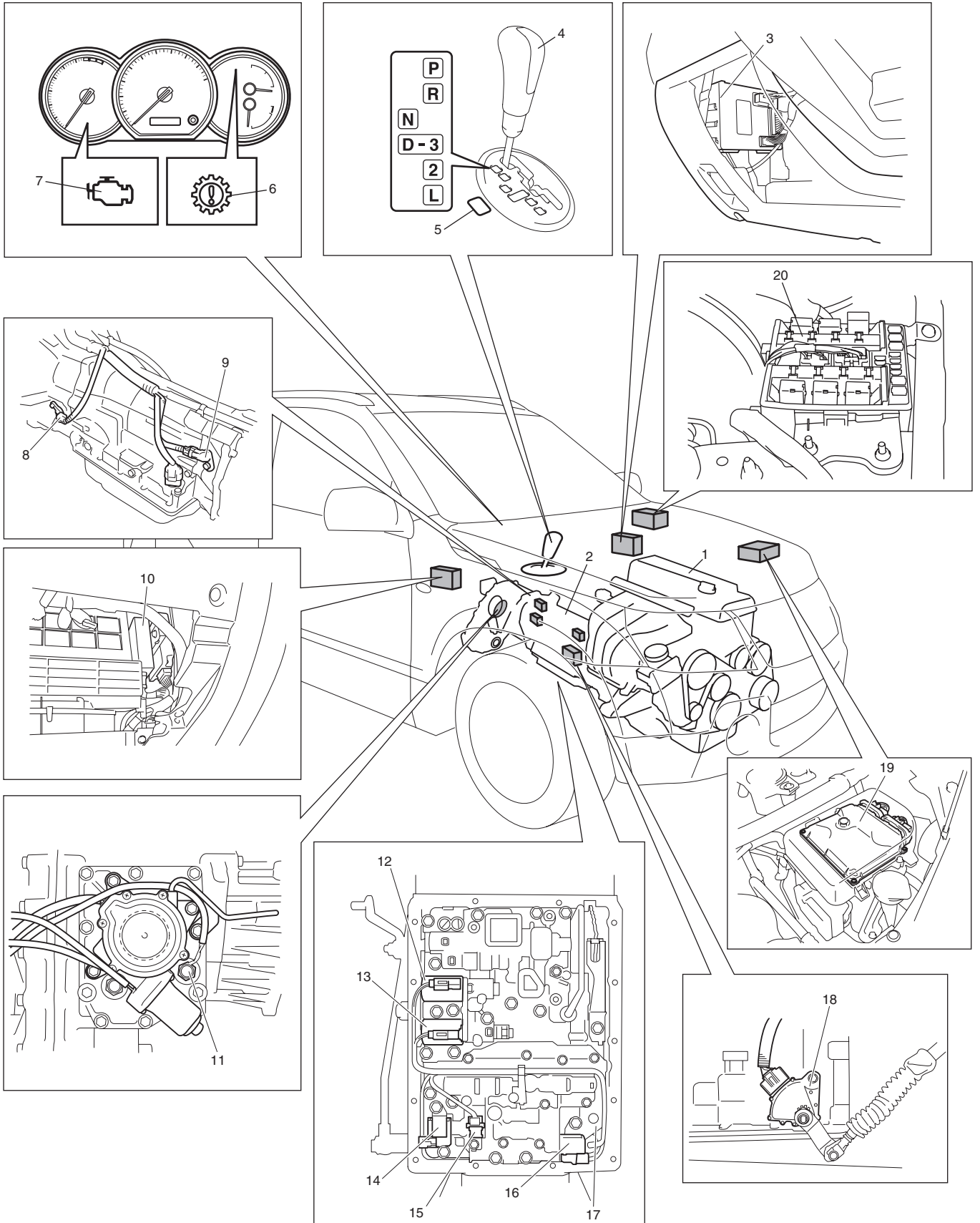

## 5A-34 Automatic Transmission/Transaxle:

- 1) Apply parking brake securely and place chocks against wheels.
- 2) Remove fluid pressure check hole plug bolt.
- 3) Attach oil pressure gauge to fluid pressure check hole in transmission case.

### Special tool

(A): 09925-37811-001

### ⚠ CAUTION

After attaching oil pressure gauge, check that no fluid leakage exists.

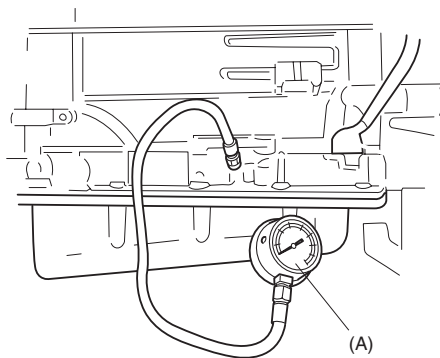

I5JB0A510019-01

- 4) Depress foot brake fully, run engine at idle and stall then check fluid pressure in "D" or "R" range.

### ⚠ CAUTION

- Do not continue running engine at stall speed longer than 5 seconds.
- After performing line pressure test, be sure to leave engine running at idle for longer than one minute before performing another line pressure test.

### Automatic transmission line pressure

	"D" range	"R" range
At idle speed	304 – 362 kPa (3.1 – 3.7 kg/cm <sup>2</sup> , 44 – 53 psi)	440 – 538 kPa (4.5 – 5.5 kg/cm <sup>2</sup> , 64 – 78 psi)
At stall speed	1161 – 1321 kPa (11.8 – 13.5 kg/cm <sup>2</sup> , 168 – 192 psi)	1485 – 1790 kPa (15.2 – 18.3 kg/cm <sup>2</sup> , 216 – 260 psi)

- 5) If check result is OK, disconnect special tool, then tighten fluid pressure check hole bolt to specified torque.

### Tightening torque

Fluid pressure check hole bolt: 8 N·m (0.8 kgf-m, 6.0 lb-ft)

### Troubleshooting

Condition	Possible cause	Correction / Reference Item
<b>Higher than standard level in each range</b>	Malfunction of pressure control solenoid valve (High line pressure)	Inspect. If NG, replace valve body assembly.
	Malfunction of primary regulator valve (High line pressure)	Replace valve body assembly.
<b>Lower than standard level in each range</b>	Malfunction of pressure control solenoid valve (Low line pressure)	Inspect. If NG, replace valve body assembly.
	Malfunction of primary regulator valve (Low line pressure)	Replace valve body assembly.
	Clogged oil strainer	Replace.
	Faulty oil pump	Inspect. If NG, replace.
	Defective O/D clutch	Inspect. If NG, replace.
	Leakage from both "D" and "R" range fluid pressure circuit	Inspect. If NG, replace valve body assembly.

**DTC P0713 Transmission Fluid Temperature Sensor “A” Circuit High****Wiring Diagram**

Refer to “DTC P0712 Transmission Fluid Temperature Sensor “A” Circuit Low: ”.

**DTC Detecting Condition and Trouble Area**

DTC Detecting Condition	Trouble Area
Transmission temperature sensor terminal voltage is less than 4.89 V under vehicle condition shown in the following. <ul style="list-style-type: none"> <li>• Ignition switch is turned on for 15 minutes or more</li> <li>• Engine coolant temperature is more than 50 °C (122 °F) (1 driving cycle detection logic)</li> </ul>	<ul style="list-style-type: none"> <li>• Transmission fluid temperature sensor or its circuit.</li> <li>• TCM</li> </ul>

**DTC Confirmation Procedure**

- 1) Connect scan tool to DLC with ignition switch OFF.
- 2) Clear DTCs in TCM and ECM memories by using scan tool.
- 3) Start engine.
- 4) Start vehicle and increase vehicle speed to about 40 km/h (25 mile/h) for 20 minutes or more.
- 5) Stop vehicle.
- 6) Check DTC, pending DTC and freeze-frame data.

**DTC Troubleshooting**

Step	Action	Yes	No
1	Was “A/T System Check” performed?	Go to Step 2.	Go to “A/T System Check: ”.
2	<b>Check transmission fluid temperature sensor circuit for open</b> <ol style="list-style-type: none"> <li>1) Turn ignition switch OFF.</li> <li>2) Disconnect TCM connectors from TCM.</li> <li>3) Check for proper connection to transmission fluid temperature sensor at terminal “E92-11” and “E92-12”.</li> <li>4) If OK, check continuity between terminal “E92-11” and “E92-12” of disconnected harness side TCM connector.</li> </ol> Is continuity indicated?	Go to Step 3.	Transmission fluid temperature sensor circuit is open circuit.
3	<b>Check transmission fluid temperature sensor circuit for power supply short</b> <ol style="list-style-type: none"> <li>1) Cool down A/T fluid temperature under ambient temperature.</li> <li>2) Connect TCM connectors to TCM with ignition switch OFF.</li> <li>3) Turn ignition switch ON.</li> <li>4) Measure voltage between terminal “E92-11” of TCM connector and ground.</li> </ol> Is it 4.89 V or more?	Transmission fluid temperature sensor circuit is shorted to power supply circuit. If circuit is OK, go to Step 4.	Intermittent trouble or faulty TCM. Check for intermittent trouble referring to “Intermittent and Poor Connection Inspection: in Section 00”. If OK, substitute a known-good TCM and recheck.
4	<b>Inspection transmission fluid temperature sensor</b> <ol style="list-style-type: none"> <li>1) Inspection transmission fluid temperature sensor referring to “Transmission Fluid Temperature Sensor Inspection: ”.</li> </ol> Is result satisfactory?	Intermittent trouble or faulty TCM. Check for intermittent trouble referring to “Intermittent and Poor Connection Inspection: in Section 00”. If OK, substitute a known-good TCM and recheck.	Replace valve body harness including transmission fluid temperature sensor referring to “Transmission Fluid Temperature Sensor Removal and Installation: ”.

DTC P1874 4L Switch Circuit Malfunction (Short)

S5JB0A5104047

Wiring Diagram

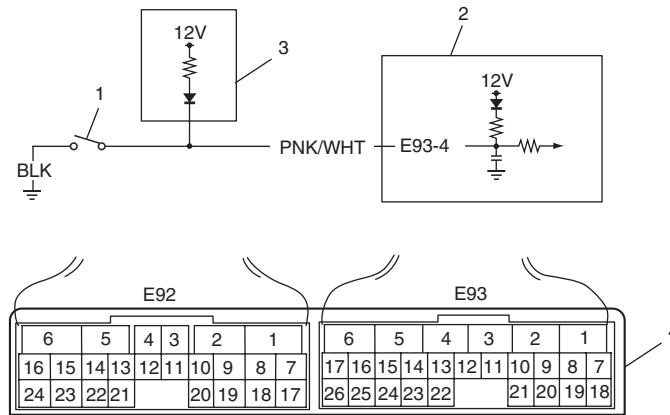

15JB0A510026-01

1. 4L/N switch	3. 4WD control module
2. TCM	4. Terminal arrangement of TCM connector (viewed from harness side)

DTC Detecting Condition and Trouble Area

DTC Detecting Condition	Trouble Area
Actual transfer position is 4H although TCM detected 4L/N switch is turned ON with vehicle speed between 29 km/h (18 mile/h) and 88 km/h (55 mile/h). (1 driving cycle detection logic)	<ul style="list-style-type: none"> <li>4L/N switch or its circuit.</li> <li>TCM</li> </ul>

DTC Confirmation Procedure

- 1) Connect scan tool to DLC with ignition switch OFF.
- 2) Clear DTCs in TCM and ECM memories by using scan tool.
- 3) Start engine and transfer position switch to "4H" position.
- 4) Keep engine running at idle speed for 10 seconds or more with select lever "D" range.
- 5) Start vehicle and increase vehicle speed to about 60 km/h (37 mile/h) for 2 minutes.
- 6) Stop vehicle.
- 7) Check DTC, pending DTC and freeze frame data.

DTC Troubleshooting

Step	Action	Yes	No
1	<p><b>Vehicle speed signal check</b></p> <p>1) Check DTC in ECM and ABS hydraulic unit / control module referring to "DTC Check: in Section 1A" or "DTC Check: in Section 4E".</p> <p><i>Is there DTC P P0500: Vehicle speed sensor (VSS) malfunction in ECM and/or DTC C1021, C1022, C1025, C1026, C1031, C1032, C1035 and/or C1036 in ABS hydraulic unit / control module?</i></p>	Go to applicable DTC diag. flow.	Go to Step 2.
2	Was "A/T System Check" performed?	Go to Step 2.	Go to "A/T System Check: "
3	Do you have SUZUKI scan tool?	Go to Step 4.	Go to Step 5.

- 3) Check that engine starts in “N” and “P” ranges but it doesn’t start in “D”, “3”, “2”, “L” or “R” range. Also, check that back-up lamp lights in “R” range. If faulty condition cannot be corrected by adjustment, disconnect transmission range sensor connector and check that continuity exists as shown by moving select lever.

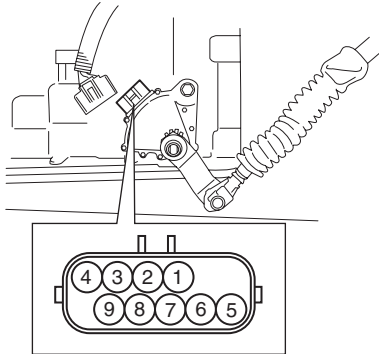

[A] \ [B]	1	2	3	4	5	6	7	8	9
P				○	○				
R	○	○							
N				○	○				
D and 3		○					○		
2		○	○						
L		○							○

I5JB0A510041-02

[A]:	Sensor position
[B]:	Terminal No.

### Key Interlock Cable Removal and Installation

S5JB0A5106051

#### NOTE

**Do not bend interlock cable excessively when removing and installing it, or system will not operate correctly.**

#### Removal

- 1) Disconnect negative (–) cable from battery.
- 2) If equipped with air bag system, disable air bag system. Refer to “Disabling Air Bag System: in Section 8B”.
- 3) Remove steering column hole cover.
- 4) Tilt steering column if steering column is adjustable. If no adjustable, loosen steering column bolts.
- 5) Remove steering column cover.
- 6) Turn ignition switch to ACC position.

- 7) Pull out key interlock cable (1) from key cylinder cover (2) while pressing checkhook with slotted screwdriver or the like.

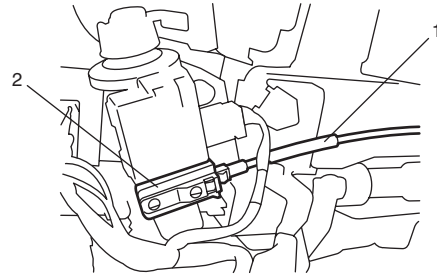

I5JB0A510062-01

- 8) Turn ignition switch to LOCK position.
- 9) Remove front console box.
- 10) Detach cable end (1) from interlock cam (2) while pressing claws (3) of interlock cam boss. At this time, be careful not to cause damage to its claws. Detach cable casing cap (4) from selector bracket (5) while pressing checkhook.
- 11) Remove interlock cable.

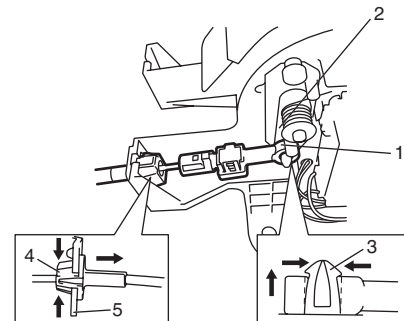

I5JB0A510063-01

#### Installation

- 1) Lay interlock cable to its original cabling route.
- 2) Turn ignition switch to “ACC” position.
- 3) Insert cable casing cap (1) into key cylinder cover (2) securely.

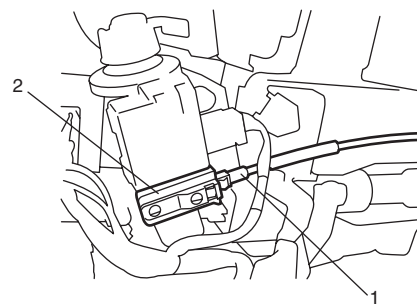

I5JB0A510064-01

## 5A-102 Automatic Transmission/Transaxle:

33) Remove manual shift shaft and lever as follows.

- a) Undo caulking of sleeve cover (1) by using flat end rod or the like and hammer.

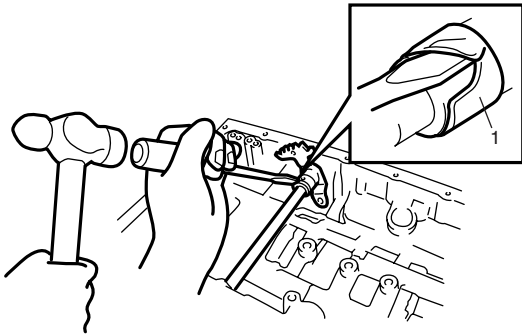

I4JA01512082-01

- b) Drive out manual shift lever pin (1) by using special tool and hammer.

**Special tool**  
**(A): 09922-89810**

- c) Pull out manual shift shaft (2) from transmission case, and then remove manual shift lever (3) and sleeve cover (4).

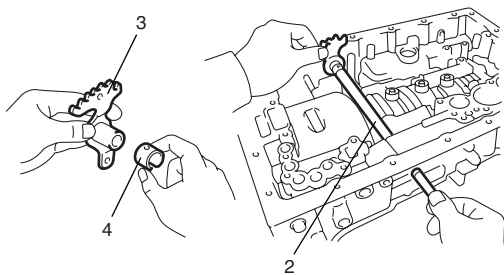
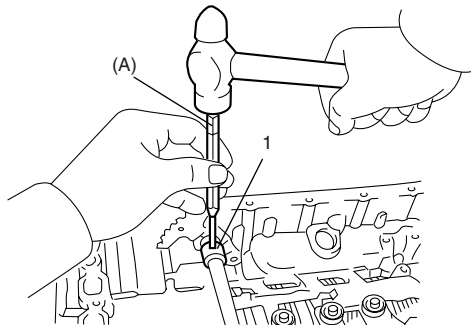

I4JA01512083-01

34) Remove oil seal (1) from both sides of transmission case.

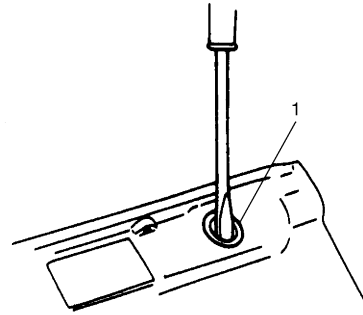

IYSQ01510111-01

35) Remove cover plate (1).

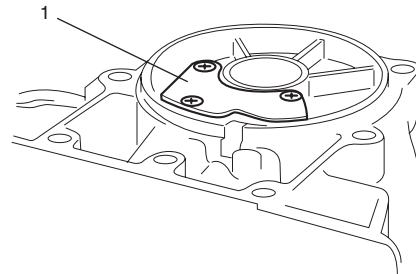

I5JB0A510089-01

**Center Support Disassembly and Assembly**

S5JB0A5106084

**Disassembly**

- 1) Remove retaining ring.

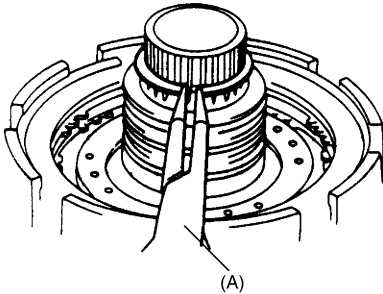
**Special tool****(A): 09920-76010**

IYSQ01510165-01

- 2) Pull out center support assembly (2) from planetary sun gear (1).

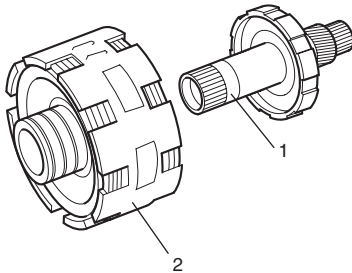

I5JB0A510117-01

- 3) Apply compressed air (400 – 800 kPa, 4 – 8 kg/cm<sup>2</sup>, 57 – 113 psi) to oil hole (1) at the extreme left and measure movement of second coast brake (Second coast brake) piston.

If measured value is not within standard range, replace second coast brake plate or second coast brake disc.

**Standard second coast brake piston movement**  
**0.75 – 1.35 mm (0.030 – 0.053 in.)**

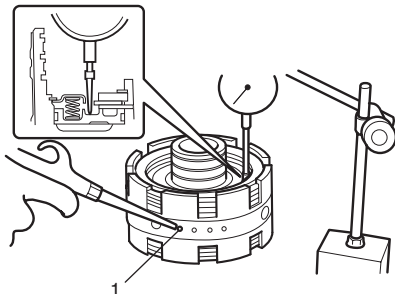

I5JB0A510118-01

- 4) Remove retaining ring.

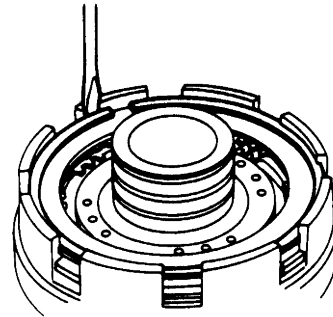

IYSQ01510168-01

- 5) After removing clutch backing plate (1), remove second coast brake plate (3) and second coast brake disc (2).

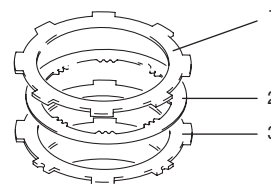

I5JB0A510119-02

- 6) Using special tool and hydraulic press, compress piston return spring and remove snap ring.

**CAUTION**

**Be careful when applying pressure, for overpressure will cause plate section of piston return spring to deform.**

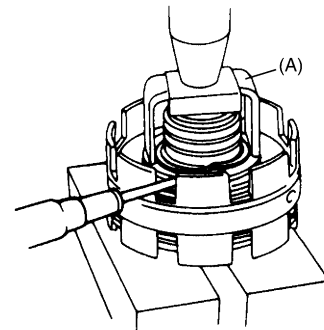
**Special tool****(A): 09926-98310**

IYSQ01510170-01

- 7) Remove brake piston return spring (1).

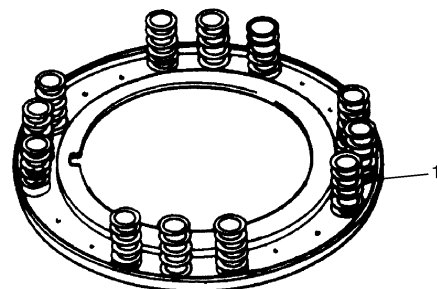

IYSQ01510171-01

## Special Tools and Equipment

### Recommended Service Material

S5JB0A5108001

**NOTE**

Required service material is also described in the following.

“Oil Pump Components: ”

“Overdrive (Planetary Gear Side) Components: ”

“Overdrive (Case Side) Components: ”

“Forward Clutch Components: ”

“Direct Clutch Components: ”

“Center Support Components: ”

“Planetary Gears and Output Shaft Components: ”

### Special Tool

S5JB0A5108002

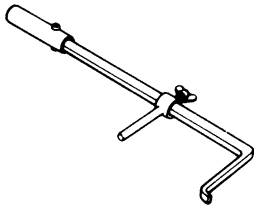
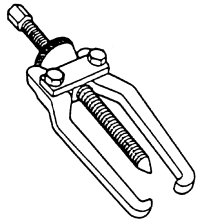
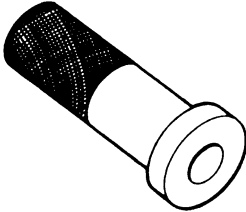
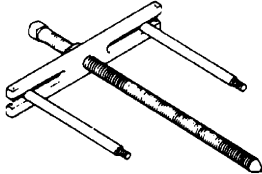
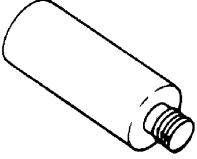
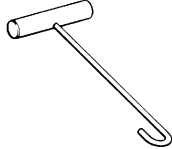
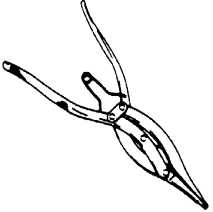
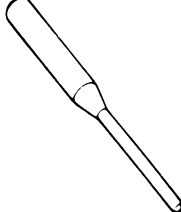
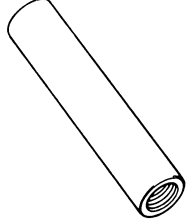
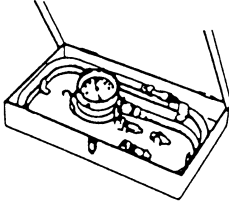
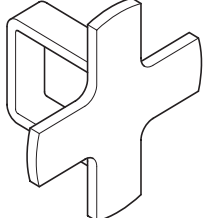
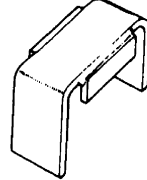
<p>09913-50121 Oil seal remover</p> 	<p>09913-65135 Bearing puller</p> 
<p>09913-85210 Bearing installer</p> 	<p>09918-48211 Oil pump remover</p> 
<p>09918-48220 Oil pump remover attachment (M8)</p> 	<p>09920-20310 Clutch spring hook</p> 
<p>09920-76010 Snap ring opener</p> 	<p>09922-89810 Shifter lock pin remover (3.5 mm)</p> 
<p>09923-46020 Joint pipe</p> 	<p>09925-37811-001 Oil pressure gauge</p> 
<p>09926-96510 Spring compressor</p> 	<p>09926-98310 Clutch spring compressor</p> 

**Remounting**

For remounting, reverse dismounting procedure.

- Apply grease to input shaft.

**“A”:** Grease 99000–25010 (SUZUKI Super Grease A)

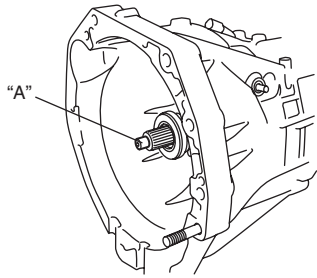

I5JB0A520031-01

- Slant the rear of the engine down, using support device (1) and install transmission to engine.

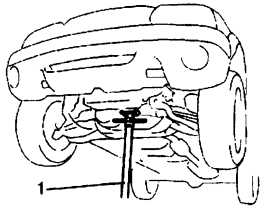

I3JA01520024-01

- Use specified torques as given below.

**Tightening torque**

**Transmission to engine bolt and nut (a): 85 N·m (8.5 kgf-m, 61.5 lb-ft)**

**Engine rear mounting member bolt (b): 55 N·m (5.5 kgf-m, 40.0 lb-ft)**

**Clutch housing lower plate bolt (c): 11 N·m (1.1 kgf-m, 8.0 lb-ft)**

**Engine rear mounting No.2 bolt (d): 55 N·m (5.5 kgf-m, 40.0 lb-ft)**

- Set each clamp for wiring and hose securely.
- Install shift control lever referring to “Transmission Shift Control Lever Removal and Installation:”.
- Connect clutch fluid joint to pipe of clutch operating cylinder assembly referring to “Clutch Operating Cylinder Assembly Removal and Installation: in Section 5C”.

- Install exhaust No.2 pipe referring to “Exhaust System Components: in Section 1K”.
- Fill gear oil to transmission referring to “Manual Transmission Oil Change:”.
- Fill gear oil to transfer referring to “Transfer Oil Change: Motor-Shift Type (Transfer with Shift Actuator) in Section 3C” or “Transfer Oil Change: Non-Shift Type (Transfer without Shift Actuator) in Section 3C”.
- Connect battery and check function of engine, clutch, transmission and transfer.
- Install propeller shafts referring to “Propeller Shaft Removal and Installation: in Section 3D”.

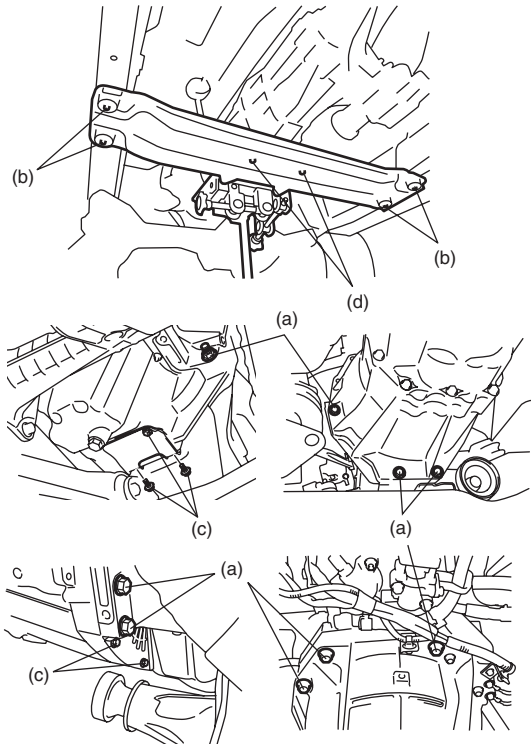

I5JB0A520032-01

**5B-33 Manual Transmission/Transaxle:**

---

09941-64511

Bearing and oil seal remover  
(30 mm Min.)

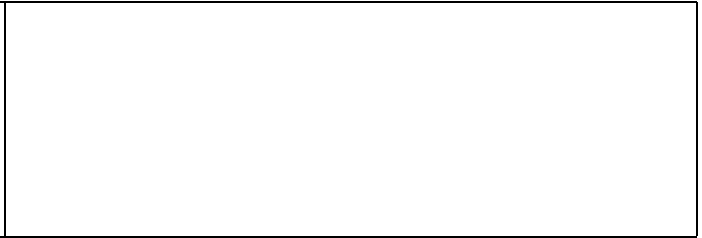
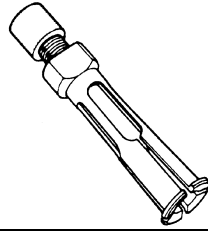

# Steering Wheel and Column

## Precautions

### Service Precautions of Air Bag Steering Wheel and Column

S5JB0A6200001

For service precautions, refer to “Precautions on Service and Diagnosis of Air Bag System: in Section 8B”.

### Handling and Storage of Air Bag Steering Wheel and Column

S5JB0A6200002

For handling and storage, refer to “Precautions on Handling and Storage of Air Bag System Components: in Section 8B”.

### Disposal of Air Bag Steering Wheel and Column

S5JB0A6200003

For disposal, refer to “Precautions on Disposal of Air Bag and Seat Belt Pretensioner: in Section 8B”.

## General Description

### Steering Wheel and Column Construction

S5JB0A6201001

This double tube type steering column has the following three important features in addition to the steering function:

- The column is energy absorbing, designed to compress in a front-end collision.
- The ignition switch and lock are mounted conveniently on this column.
- With the column mounted lock, the ignition and steering operations can be locked to inhibit theft of the vehicle.

To insure the energy absorbing action, it is important that only the specified screws, bolts and nuts be used as designated, and that they are tightened to the specified torque. When the column assembly (6) is removed from the vehicle, special care must be taken in handling it. Use of a steering wheel puller or a sharp blow on the end of the steering shaft, leaning on the assembly, or dropping the assembly could shear the plastic shear pins which maintain column length and position.

The driver air bag (inflator) module is one of the supplemental restraint (air bag) system components and is mounted to the center of the steering wheel (1). During certain frontal crashes, the air bag system supplements the restraint of the driver's and passenger's seat belts by deploying the air bags. The air bag (inflator) module should be handled with care to prevent accidental deployment. When servicing, be sure to observe “Precautions on Service and Diagnosis of Air Bag System: in Section 8B”.

## 6C-4 Power Assisted Steering System:

Condition	Possible cause	Correction / Reference Item
<b>Poor recovery from turns</b>	Deformed pipes or hoses	Replace defective part.
	Steering column installed improperly	Install steering column correctly.
	Front end alignment out of order	Check and adjust front end alignment.
	Ball joints binding	Replace defective part.
	P/S pump hydraulic pressure fails to increase	Check pressure and repair or replace defective part.
	P/S pump hydraulic pressure increases but slowly	Check pressure and repair or replace defective part.
	Steering gear case malfunction	Replace gear case.
<b>Vehicle pulls to one side during straight driving</b>	Mismatched or uneven tire	Replace tire.
	Low or uneven tire inflation pressure	Inflate tires to proper pressure or adjust right and left tires inflation pressure.
	Brake dragging in one wheel	Repair.
	Front end alignment out of order	Check and adjust front end alignment.
	Rear end alignment out of order	Check and adjust rear end alignment.
	Malfunction of control valve in gear case	Replace gear case.
<b>Steering wheel play is large and vehicle wanders</b>	Refer to "Steering Symptom Diagnosis: in Section 6A".	
<b>Fluid leakage</b>	Loose joints of (hydraulic pressure) pipes and hoses	Retighten.
	Deformed or damaged pipes or hoses	Replace defective part.
<b>Abnormal noise</b>	Air drawn in due to insufficient amount of fluid	Add fluid and purge air.
	Air mixed into fluid from pipes or hoses	Replace pipes or hoses.
	Slipping (loose) P/S belt	Adjust belt tension.
	Worn P/S belt	Replace belt.
	Loose gear case fastening bolt	Retighten bolts.
	Loose linkage or joints	Retighten.
	Pipes or hoses in contact with part of vehicle body	Install pipes and hoses correctly.
	Vanes of P/S pump defective	Replace defective part.
	Malfunction of control valve in gear case	Replace gear case.
	Bearing of P/S pump shaft defective	Replace bearing.
<b>No idle up</b>	Power steering pressure switch defective	Replace power steering pressure switch.

### Steering Wheel Check

S5JB0A6304002

- Check steering wheel for looseness or rattle by trying to move it in its shaft direction and lateral direction. If found defective, repair or replace.
- Check steering wheel for play, holding car in straight forward condition on the ground and with engine stopped.

#### Steering wheel play

"a": 0 – 30 mm (0 – 1.2 in.)

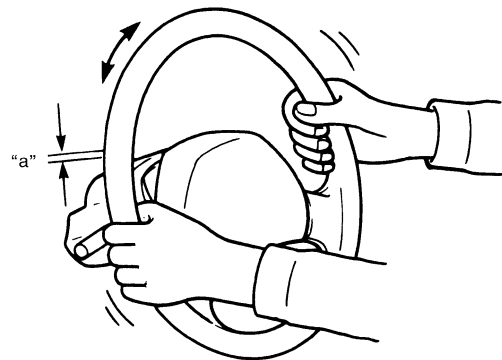

I5JB0A630004-02

If steering wheel play is not within specification, inspect as follows and replace if found defective.

- Tie-rod end ball stud for wear
- Lower ball joint for wear
- Steering shaft joint for wear
- Steering pinion or rack gear for wear or breakage
- Each part for looseness

- 4) Apply power steering fluid to sliding surface of rotor (1).
- 5) Install rotor (1) to shaft, directing dot (3) marked side of rotor facing up.
- 6) Install new snap ring (2) to shaft, then make sure to fit snap into shaft groove securely.

**NOTE**

**Never reuse the removed snap ring (2).**

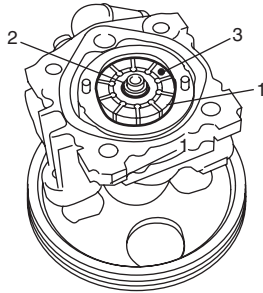

I5JB0A630033-01

- 7) Apply power steering fluid to sliding surface of cam ring (1).
- 8) Apply power steering fluid to each vane (2).
- 9) Install vanes (2) (10 pieces) to rotor (1).

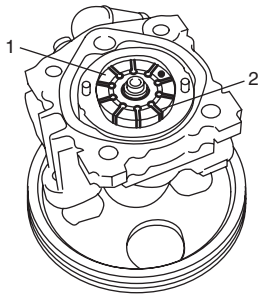

I5JB0A630034-01

- 10) Apply power steering fluid to O-ring (1).
- 11) Install O-ring (1) to pump body.

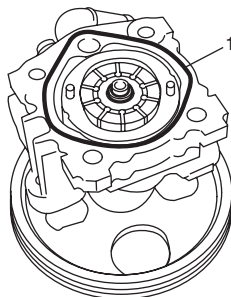

I5JB0A630035-01

- 12) Apply power steering fluid to sliding surface of pump cover and rotor.
- 13) Match the dowel pins (1) to the holes of the cover plate (2) as shown and install pump cover to pump body.

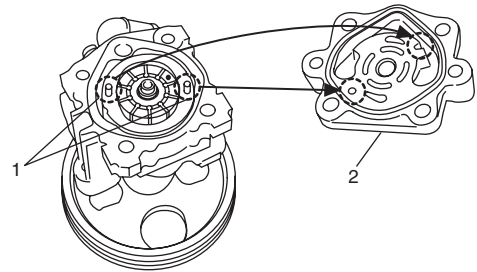

I5JB0A630036-01

- 14) Gradually tighten pump cover (1) bolts to diagonally specified torque.

**NOTE**

**After installing pump cover (1), check to make sure that shaft can be turned by hand.**

**Tightening torque**

**P/S pump cover bolt (a): 28 N-m (2.8 kgf-m, 20.5 lb-ft)**

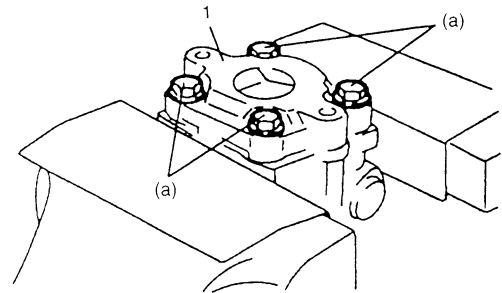

IYSQ01630049-01

- 15) Apply power steering fluid to O-ring (2) of pressure switch.
- 16) Install O-ring (2) to pressure switch.
- 17) Install pressure switch (1) to pump body.

**Tightening torque**

**Pressure switch for M16 engine model (a): 28 N-m (2.8 kgf-m, 20.5 lb-ft)**

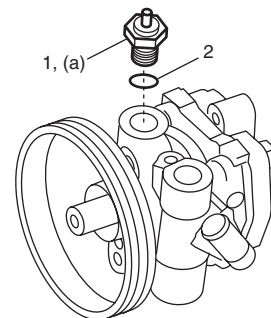

I5JB0A630037-04

## Blower Motor Controller Removal and Installation

S5JB0A7106005

### Removal

- 1) Disconnect negative (–) cable at battery.
- 2) Disable air bag system referring to “Disabling Air Bag System: in Section 8B”.
- 3) Remove glove box.
- 4) Remove passenger lower member.
- 5) Disconnect blower motor controller coupler (3).
- 6) Remove blower motor controller (1) by loosening its fastening screws (2).

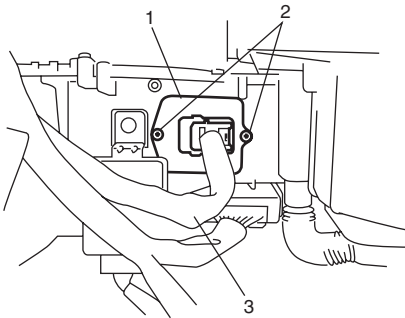

I5JB0A710009-01

### Installation

- 1) Reverse removal procedure.
- 2) Enable air bag system referring to “Enabling Air Bag System: in Section 8B”.

### Blower Motor Controller Inspection

S5JB0A7106006

Check controller for operation as follows.

- Using service wire, connect battery positive terminal to “1” terminal (1) of blower motor controller (6) and battery negative terminal to “2” terminal (2) of blower motor controller.
- Using bulb (3.4 W) (4) and service wire, connect battery positive terminal to “3” terminal (3) of blower motor controller as shown figure.
- Arrange 3 new 1.5 V batteries (5) in series (check that total voltage is 4.5 – 5.0 V) and connect its positive terminal to “3” terminal of blower motor controller and negative terminal to “2” terminal of blower motor controller. Then, check that bulb lights. If bulb does not light under the above conditions, replace blower motor controller.

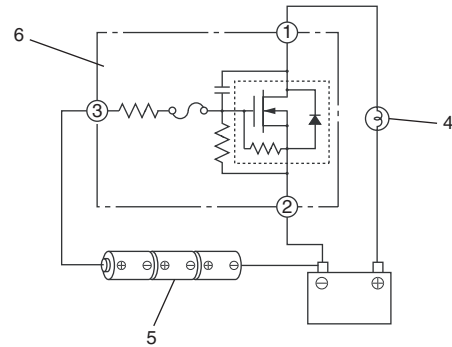
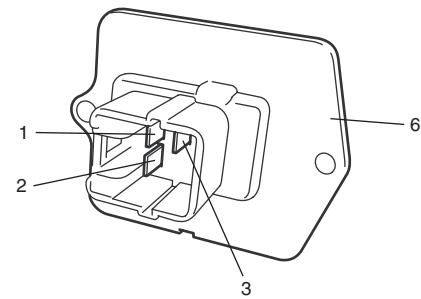

I5JB0A710010-01

### Blower Motor Relay Inspection

S5JB0A7106008

- 1) Disconnect negative (–) cable at battery.
- 2) Remove blower motor relay (1) from vehicle.
- 3) Check that there is no continuity between terminal “c” and “d”. If there is continuity, replace relay.
- 4) Connect battery positive (+) terminal to terminal “b” of relay.  
Connect battery negative (–) terminal to terminal “a” of relay.  
Check continuity between terminal “c” and “d”.  
If there is no continuity when relay is connected to the battery, replace relay.

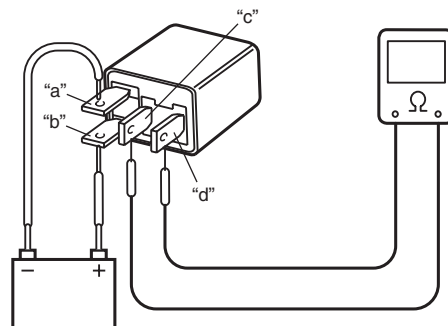
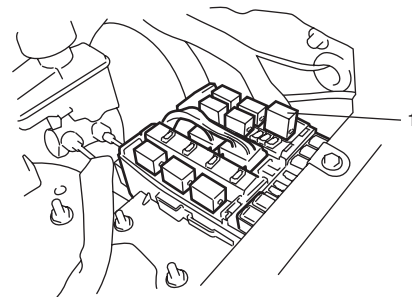

I5JB0A710011-01

**Customer Complaint Analysis**

Record details of the problem (failure, complaint) and how it occurred as described by the customer.

For this purpose, use of such a questionnaire form as shown in the figure will facilitate collecting information to the point required for proper analysis and diagnosis.

**Customer questionnaire (example)**

Customer's Name:	Model:	VIN:	
Date of Issue:	Date Reg.	Date of Problem:	Mileage:
Problem Symptoms	<ul style="list-style-type: none"> <li>• "FRE" indicator lamp abnormal: fails to turn ON / fails to go OFF / flashes</li> <li>• Abnormal noise while "A/C" switch is turned ON: from compressor, from radiator fan motor, other _____</li> <li>• Cool air does not come out:</li> <li>• Radiator fan motor does not work:</li> <li>• A/C compressor does not work:</li> <li>• Blower fan motor does not work:</li> </ul>		
Frequency of Occurrence	• Continuous / Intermittent ( _____ times a day, a month) / other _____		
Conditions for Occurrence of Problem	<ul style="list-style-type: none"> <li>• Vehicle at stop &amp; A/C compressor is working:</li> <li>• For some time after A/C switch is ON:</li> <li>• When outside air temperature is high:</li> <li>• When outside air temperature is low:</li> <li>• All the time:</li> </ul>		
Environmental Condition	<ul style="list-style-type: none"> <li>• Weather: fair / cloudy / rain / snow / other _____</li> <li>• Temperature: _____ °F ( _____ °C)</li> </ul>		
DTC	<ul style="list-style-type: none"> <li>• First check: Normal code / malfunction code ( _____ )</li> <li>• Second check: Normal code / malfunction code ( _____ )</li> </ul>		

**NOTE**

**The form is a standard sample. It should be modified according to conditions characteristic of each market.**

**Visual Inspection**

As a preliminary step, be sure to perform visual check of the items that support proper function of the air conditioning system referring to "Visual Inspection: ".

**DTC Check**

Refer to "DTC Check: " for checking procedure.

**Troubleshooting for DTC**

Based on the DTC indicated in Step 4 and referring to applicable DTC flow, locate the cause of the trouble, namely in a sensor, actuator, wire harness, connector, HVAC control module or other part and repair or replace faulty parts.

**Check for Intermittent Problem**

Check parts where an intermittent trouble is easy to occur (e.g., wire harness, connector, etc.), referring to "Intermittent and Poor Connection Inspection: in Section 00".

**Air Conditioning System Symptom Diagnosis**

Check the parts or system suspected as a possible cause referring to "A/C System Symptom Diagnosis: ".

**Final Confirmation Test**

Confirm that the problem symptom has gone and the air conditioning system is free from any abnormal conditions. If what has been repaired is related to the malfunction DTC, check DTC once and confirm that no DTC is indicated.

**7B-29 Air Conditioning System:****Abnormal Noise from Magnetic Clutch**

<b>Condition</b>	<b>Possible cause</b>	<b>Correction / Reference Item</b>
<b><i>A rumbling noise is heard when compressor is not in operation</i></b>	Worn or damaged bearings	<i>Replace magnet clutch assembly.</i>
<b><i>A chattering noise is heard when compressor is in operation</i></b>	Faulty magnet clutch clearance (excessive clearance)	<i>Adjust magnet clutch clearance.</i>
	Worn magnet clutch friction surface	<i>Replace magnet clutch assembly.</i>
	Compressor oil leaked from shaft seal, contaminating the friction surface	<i>Replace compressor body assembly.</i>

**Abnormal Noise from Tubing**

<b>Condition</b>	<b>Possible cause</b>	<b>Correction / Reference Item</b>
<b><i>A droning noise is heard from inside of the vehicle, but not particularly noticeable in engine compartment</i></b>	Faulty tubing clamps	<i>Reposition clamps or increase the number of clamps.</i>
	Resonance caused by pulsation from variations in refrigerant pressure	<i>Attach a silencer to tubing, or modify its position and length.</i>

**Abnormal Noise from Condenser Assembly**

<b>Condition</b>	<b>Possible cause</b>	<b>Correction / Reference Item</b>
<b><i>Considerable vibration in condenser assembly</i></b>	Resonance from condenser assembly bracket and body	<i>Firmly insert a silencer between condenser assembly bracket and body.</i>

**Abnormal Noise from Crankshaft Pulley**

<b>Condition</b>	<b>Possible cause</b>	<b>Correction / Reference Item</b>
<b><i>A large rattling noise is heard at idle or sudden acceleration</i></b>	Loosen crankshaft pulley bolt	<i>Retighten bolt.</i>

**Abnormal Noise from Tension Pulley**

<b>Condition</b>	<b>Possible cause</b>	<b>Correction / Reference Item</b>
<b><i>Clattering noise is heard from pulley</i></b>	Worn or damaged bearing	<i>Replace tension pulley.</i>
<b><i>Pulley cranks upon contact</i></b>	Cracked or loose bracket	<i>Replace or retighten bracket.</i>

**Abnormal Noise from A/C Evaporator**

<b>Condition</b>	<b>Possible cause</b>	<b>Correction / Reference Item</b>
<b><i>Whistling sound is heard from A/C evaporator</i></b>	Depending on the combination of the interior / exterior temperatures, engine rpm and refrigerant pressure, the refrigerant flowing out of the expansion valve may, under certain conditions, make a whistling sound	<i>At times, slightly decreasing refrigerant volume may stop this noise. Inspect expansion valve and replace if faulty.</i>

**Abnormal Noise from Blower Motor**

<b>Condition</b>	<b>Possible cause</b>	<b>Correction / Reference Item</b>
<b><i>Blower motor emits a chirping sound in proportion to its speed of rotation</i></b>	Worn or damaged motor brushes or commutator	<i>Replace blower motor.</i>
<b><i>Fluttering noise or large droning noise is heard from blower motor</i></b>	Leaves or other debris introduced from fresh air inlet to blower motor	<i>Remove debris and make sure that the screen at fresh air inlet is intact.</i>

**DTC Detecting Condition and Trouble Area****NOTE**

When DTC B1502, B1503, B1511 and B1512 are indicated together, it is that "BLK/RED" wire circuit open.

DTC Detecting Condition	Trouble Area
Air intake control actuator position sensor signal voltage is more than or less than specified value for specified time continuously.	<ul style="list-style-type: none"> <li>• Air intake control actuator circuit</li> <li>• Air intake control actuator</li> <li>• HVAC control module</li> </ul>

**DTC Confirmation Procedure**

- 1) Connect scan tool to DLC with ignition switch turned OFF.
- 2) Turn ON ignition switch and clear DTC using scan tool.
- 3) Check DTC.

**DTC Troubleshooting**

Step	Action	Yes	No
1	<p><b>Position sensor power supply circuit check</b></p> <ol style="list-style-type: none"> <li>1) Disconnect air intake control actuator connector with ignition switch turned OFF.</li> <li>2) Check for proper connection to air intake control actuator at "RED/WHT", "WHT/GRN" and "BLK/RED" wire terminals.</li> <li>3) If OK, measure voltage between "RED/WHT" wire terminal of air flow control actuator connector and vehicle body ground with ignition switch turned ON.</li> </ol> <p><i>Is voltage 4 – 6 V?</i></p>	Go to Step 6.	Go to Step 2.
2	<p><b>Position sensor power supply circuit check</b></p> <ol style="list-style-type: none"> <li>1) Disconnect temperature control actuator connector with ignition switch turned OFF.</li> <li>2) Measure voltage between "RED/WHT" wire terminal of air intake control actuator connector and vehicle body ground with ignition switch turned ON.</li> </ol> <p><i>Is voltage 4 – 6 V?</i></p>	Temperature control actuator faulty.	Go to Step 3.
3	<p><b>Position sensor power supply circuit check</b></p> <ol style="list-style-type: none"> <li>1) Disconnect air flow control actuator connector with ignition switch turned OFF.</li> <li>2) Measure voltage between "RED/WHT" wire terminal of air intake control actuator connector and vehicle body ground with ignition switch turned ON.</li> </ol> <p><i>Is voltage 4 – 6 V?</i></p>	Air flow control actuator faulty.	Go to Step 4.
4	<p><b>Position sensor power supply circuit check</b></p> <ol style="list-style-type: none"> <li>1) Disconnect connector from HVAC control module with ignition switch turned OFF.</li> <li>2) Check for proper connection to HVAC control module connector at "G52-14", "G52-22" and "G52-13" terminals.</li> <li>3) If OK, measure resistance between "RED/WHT" wire terminal of air intake control actuator connector and "G52-14" terminal of HVAC control module connector.</li> </ol> <p><i>Is resistance below 5 Ω?</i></p>	Go to Step 5.	"RED/WHT" wire open or high resistance circuit.

## 7B-63 Air Conditioning System:

### Check A/C System for Refrigerant Leaks

Whenever a refrigerant leak is suspected in the system or any service operation has been performed which may result in malfunction lines and/or connections, it is advisable to check for leaks.

Common sense should be used in performing any refrigerant leak test, since the need and extent of any such test will, in general, depend upon the nature of a complaint and the type of a service performed on the system.

### Liquid leak detector

#### **⚠ WARNING**

- To prevent explosions or fires, make sure that there are no flammables in the vicinity.
- When exposed to fire, the refrigerant turns into a poisonous gas (phosgene). Do not inhale this gas.

There are a number of fittings and places throughout the air conditioning system where a liquid leak detector solution may be used to pinpoint refrigerant leaks.

By merely applying the solution to the area in question with a swab, such as attached to the bubbles will form within seconds if there is a leak.

For confined areas, such as sections of the evaporator and condenser, an electronic (gas) leak detector (1) is more practical for determining leaks.

### Special tool

(A): 09990-86011

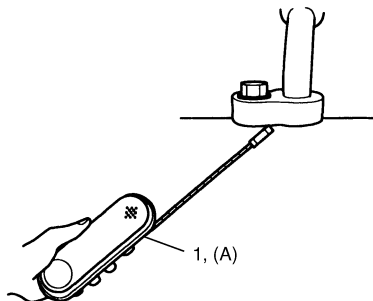

I5JB0A720035-01

## A/C Condenser Assembly On-Vehicle Inspection

S5JB0A7206002

### **⚠ CAUTION**

**Be careful not to damage condenser fins. If condenser fin is bent, straighten it by using a screwdriver or pair of pliers. If any leakage is found from fitting or tube, repair or replace condenser.**

### **NOTE**

**Clogged condenser fins should be washed with water, and should be dried with compressed air.**

Check the followings.

- Clog of condenser fins.  
If any clog is found, condenser fins should be washed with water and should be dried with compressed air.
- Condenser fins for leakage and breakage If any defects are found, repair or replace condenser.
- Condenser fittings for leakage. If any defects are found, repair or replace condenser.

## A/C Condenser Assembly Removal and Installation

S5JB0A7206003

### **⚠ CAUTION**

**Do not damage condenser fins. If condenser fin is bent, straighten it by using flat head screwdriver or pair of pliers.**

### Removal

- 1) Disconnect negative (-) cable at battery.
- 2) Recover refrigerant from A/C system referring to "Operation Procedure for Charging A/C with Refrigerant: ".

### **NOTE**

**The amount of removed compressor oil must be measured for replenishing compressor oil.**

## Magnet Clutch Removal and Installation for J20 Engine Model

S5JB0A7206049

### Removal

- 1) Remove compressor from vehicle referring to "Compressor Assembly Removal and Installation for J20 Engine Model: ".
- 2) Fix armature plate (1) with special tool (A) and remove armature plate bolt.

#### Special tool

(A): 09991-06310

#### NOTE

Do not reuse armature plate bolt.

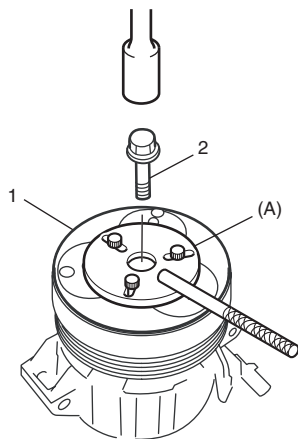

I5JB0A720071-01

- 3) Remove armature plate.
- 4) Remove shim(s) from shaft.
- 5) Using special tool (A), remove snap ring (1).

#### Special tool

(A): 09900-06107

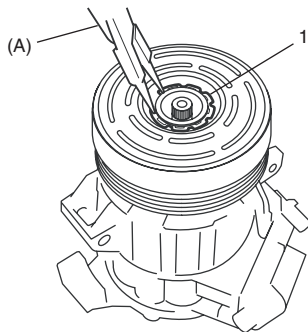

I5JB0A720072-01

- 6) Remove magnet clutch pulley (1) with puller (2).

#### NOTE

Be careful not to damage pulley.

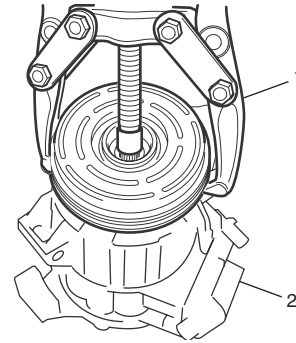

I5JB0A720073-01

- 7) Remove snap ring (1) using special tool (B), and then remove magnet clutch coil (1).

#### Special tool

(A): 09900-06107

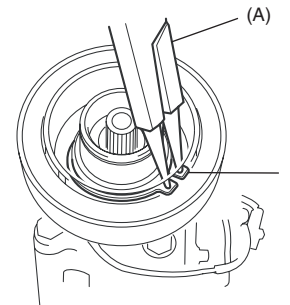

I5JB0A720074-02

### Installation

- 1) Install magnet clutch coil (3).

#### NOTE

Protrusion (1) on underside of magnet clutch coil and hole (2) on compressor body assembly must match to stop movement of magnet clutch coil and to locate lead wire correctly.

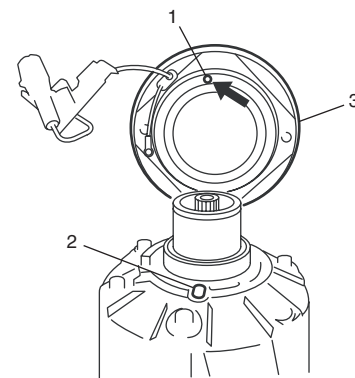

I5JB0A720075-01

## 8B-2 Air Bag System:

- Never attempt disassembly of SDM.
- When storing SDM, select a place where neither high temperature nor high humidity is anticipated and oil, water and dust are kept off.

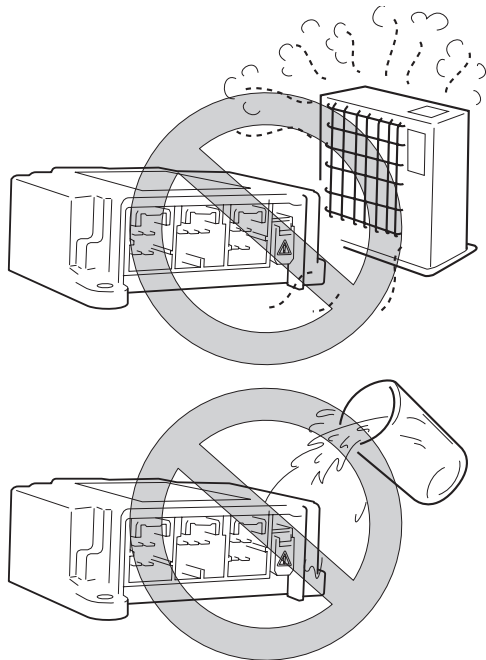

15JB0A820001-02

- If SDM has been dropped, replace it with a new one.
- If SDM installation part of floor was damaged, repair that part completely before reinstallation.
- All SDM and mounting bracket fasteners must be carefully torqued and the arrow must be pointed toward the front of the vehicle to ensure proper operation of the air bag system.

### Live (Undeployed) Air Bag (Inflator) Modules

Special care is necessary when handling and storing a live (undeployed) air bag (inflator) modules.

The rapid gas generation produced during deployment of the air bag could cause the air bag (inflator) module, or an object in front of the air bag (inflator) module, to be thrown through the air in the unlikely event of an accidental deployment.

#### **▲ WARNING**

**Never attempt to measure the resistance of the air bag (inflator) modules (driver, passenger and side of both sides and curtain of both sides). It is very dangerous as the electric current from the tester may deploy the air bag.**

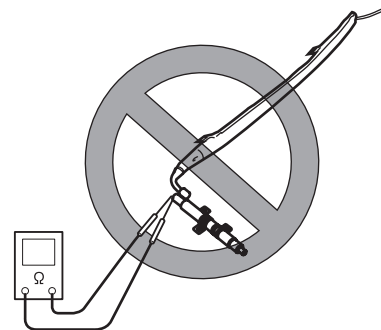
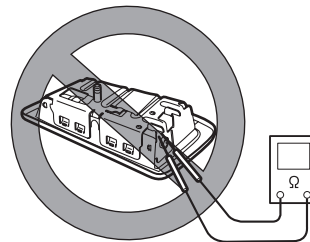
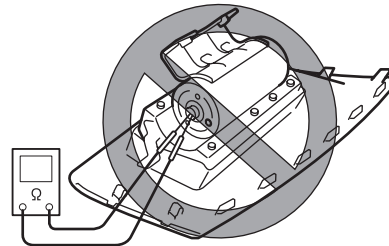
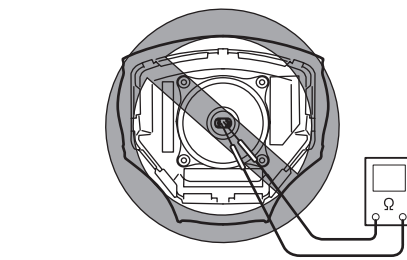

15JB0A820002-02

- Never attempt disassembly of the air bag (inflator) modules.
- If any abnormality is found, be sure to replace it with new one as an assembly.
- When an abnormality is noted as existing in the live (undeployed) air bag (inflator) module, be sure to deploy it before discarding it.
- When grease, cleaning agent, oil, water, etc., got on the air bag (inflator) modules (driver, passenger, side of both sides and curtain of both sides), wipe it off immediately with a dry cloth.
- If air bag (inflator) module was dropped from a height of 90 cm (3 ft) or more, it should be replaced with a new one as an assembly.

“AIR BAG” Warning Lamp Comes ON Steady

Wiring Diagram

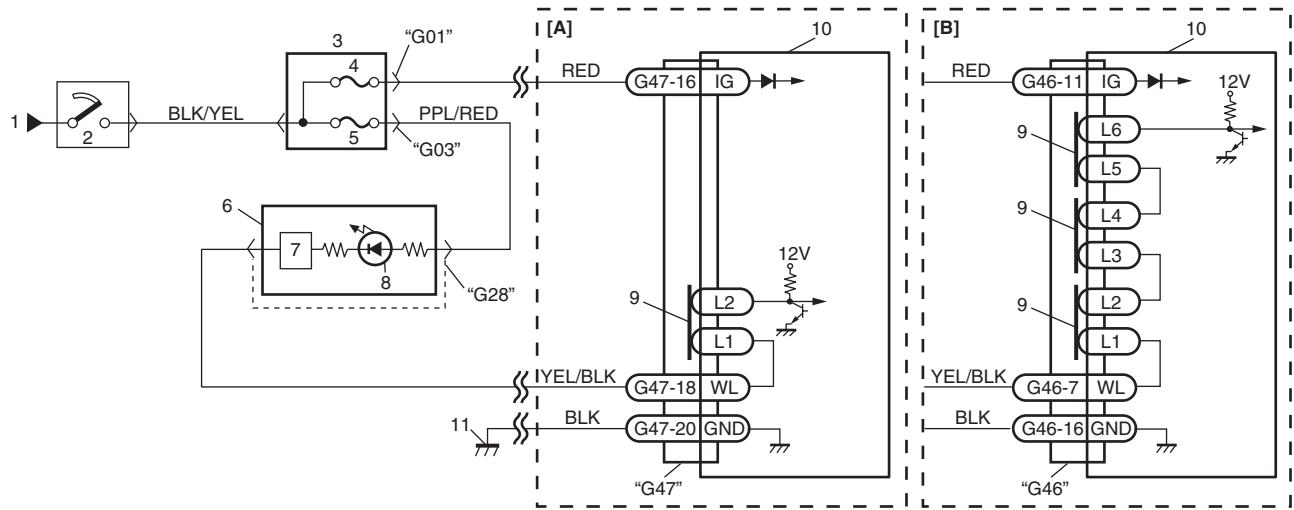

I5JB0A820017-01

[A]: Without side-air bag and curtain-air bag	3. Junction block assembly	7. Lamp driver	11. Ground for air bag system
[B]: With side-air bag and curtain-air bag	4. "A/B" fuse	8. "AIR BAG" warning lamp	
1. From main fuse	5. "METER" fuse	9. Connection detection pin	
2. Ignition switch	6. Combination meter	10. SDM	

**⚠ CAUTION**

**Be sure to observe instructions under CAUTION in “Air Bag Diagnostic System Check Flow”.**

**8B-36 Air Bag System:**

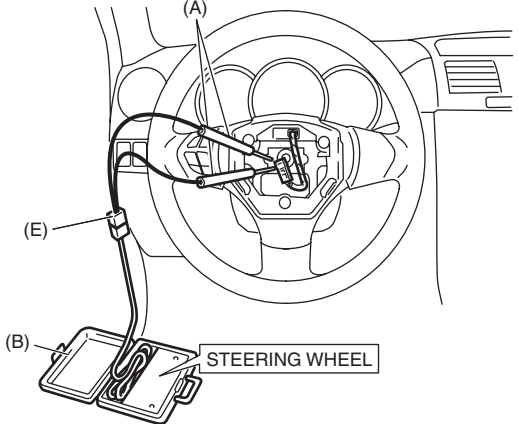
Step	Action	Yes	No
3	<p>1) With ignition switch OFF, disconnect special tools (B) and (C) or (D) from "G26" or "G27" connector and reconnect contact coil connector located under of the steering column.</p> <p>2) Remove driver air bag (inflator) module from steering column referring to "Driver Air Bag (Inflator) Module Removal and Installation: ".</p> <p>3) Check proper connection to driver air bag (inflator) module connector.</p> <p>4) If OK, then connect special tools (A), (B) and (E) to driver air bag (inflator) module connector.</p> <p><b>Special tool</b>  <b>(A): 09932-76010</b>  <b>(B): 09932-75010</b>  <b>(C): 09932-78340</b>  <b>(D): 09932-77320</b>  <b>(E): 09932-78310</b></p>  <p>5) Check SDM DTC.</p> <p><i>With ignition switch ON, is DTC B1032 indicated?</i></p> <p style="text-align: right;">15JB0A820028-01</p>	<p>Turn ignition switch OFF. Replace contact coil assembly referring to "Contact Coil Cable Assembly Removal and Installation: in Section 6B".</p>	<p>Turn ignition switch OFF. Replace driver air bag (inflator) module referring to "Driver Air Bag (Inflator) Module Removal and Installation: ".</p>

**NOTE**

Upon completion of inspection and repair work, perform the following items.

- Reconnect all air bag system components and ensure all components are properly mounted.
- Clear DTCs referring to "DTC Clearance: ", if any.
- Repeat "Air Bag Diagnostic System Check: " to confirm that the trouble has been corrected.

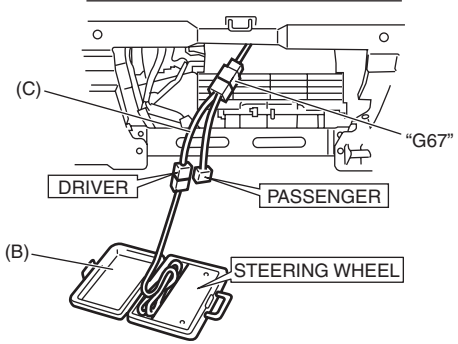
Step	Action	Yes	No
2	<p>1) With ignition switch OFF, disconnect "G67" connector located near the glove box.</p> <p>2) Check proper connection to instrument panel harness connector at terminal "G67-1" and "G67-2".</p> <p>3) If OK, then connect special tools (B) and (C) to "G67" connector disconnected in Step 1).</p> <p><b>Special tool</b>  <b>(B): 09932-75010</b>  <b>(C): 09932-77320</b></p>  <p style="text-align: right; font-size: small;">I5JB0A820034-01</p> <p>4) Check SDM DTC.</p> <p><i>With ignition switch ON, is DTC B1044 indicated?</i></p>	Go to Step 3.	"BLU/RED" or "YEL/RED" circuit shorted to power supply circuit. (Between "G68" and "G65" connectors)

**8B-70 Air Bag System:**

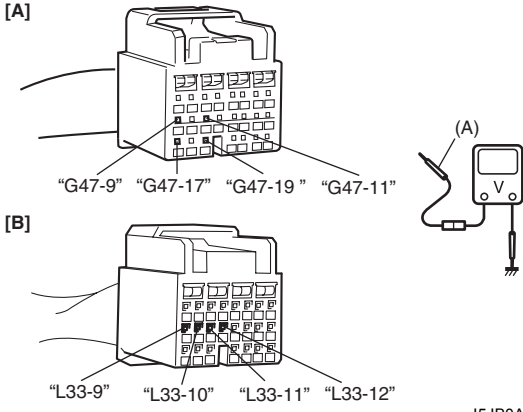
Step	Action	Yes	No
2	<p>1) Disconnect service wire from "E13" or "E24" connector.</p> <p>2) Measure voltage between "G47-9" and body ground, "G47-17" and body ground (for DTC B1074) or "G47-11" and body ground, "G47-19" and body ground (for DTC B1078) [A], or between "L33-9" and body ground, "L33-10" and body ground (for DTC B1074) or "L33-11" and body ground, "L33-12" and body ground (for DTC B1078) [B].</p> <p><b>Special tool</b> <b>(A): 09932-76010</b></p>  <p style="text-align: right; font-size: small;">I5JB0A820052-01</p> <p><i>With ignition switch ON, is each measured value 1 V or less?</i></p>	Go to Step 3.	<p>For DTC B1074: "ORN" circuit or "PNK/BLK" circuit shorted to power circuit.</p> <p>For DTC B1078: "PNK" circuit or "PNK/BLU" circuit shorted to power circuit.</p>
3	<p>1) Check forward-sensor referring to "Forward-Sensor Inspection: ".</p> <p><i>Is it in good condition?</i></p>	Substitute a known-good SDM and recheck.	Replace forward-sensor referring to "Forward-Sensor Removal and Installation: ". If DTC still exists, substitute a known-good SDM and recheck.

**NOTE**

Upon completion of inspection and repair work, perform the following items.

- Reconnect all air bag system components and ensure all components are properly mounted.
- Clear DTCs referring to "DTC Clearance: ", if any.
- Repeat "Air Bag Diagnostic System Check: " to confirm that the trouble has been corrected.

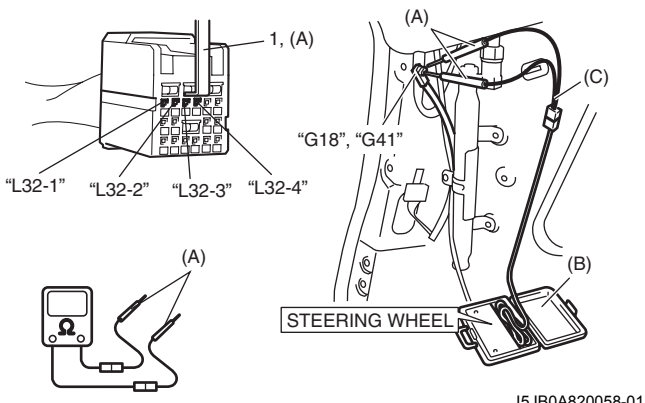
Step	Action	Yes	No
2	<p>1) With ignition switch OFF, disconnect SDM connector "L32".</p> <p>2) Check proper connection to SDM at terminals "L32-1" and "L32-2" or "L32-3" and "L32-4".</p> <p>3) If OK, release shorting bar in SDM connector inserting release tool (1) included in special tool (A).</p> <p>4) Measure resistance between "L32-1" and "L32-2" terminals (for DTC B1331) or "L32-3" and "L32-4" terminals (for DTC B1335) with connected special tools (A), (B) and (C).</p> <p><b>Special tool</b>  <b>(A): 09932-76010</b>  <b>(B): 09932-75010</b>  <b>(C): 09932-78310</b></p>  <p>The diagram illustrates the diagnostic procedure. On the left, a close-up of the SDM connector shows terminals L32-1, L32-2, L32-3, and L32-4. A release tool (1) is shown being inserted into the connector. On the right, a steering wheel is shown with special tools (A), (B), and (C) connected to the air bag system. Terminals G18 and G41 are also labeled. A multimeter is shown measuring resistance between terminals (A) and (B). The text 'STEERING WHEEL' is written below the wheel. The part number I5JB0A820058-01 is at the bottom right of the diagram.</p> <p><i>Is resistance 5.5 Ω or less?</i></p>	Substitute a known-good SDM and recheck.	<p>DTC B1331: Repair high resistance or open in "YEL/GRN" or "YEL/BLU" wire circuit.</p> <p>DTC B1335: Repair high resistance or open in "BLK/YEL" or "BRN/YEL" wire circuit.</p>

**NOTE**

Upon completion of inspection and repair work, perform the following items.

- Reconnect all air bag system components, ensure all components are properly mounted.
- Clear DTCs referring to "DTC Clearance: ", if any.
- Repeat "Air Bag Diagnostic System Check: " to confirm that the trouble has been corrected.

**⚠ WARNING**

- When carrying a live air bag (inflator) module, make sure the bag opening is pointed away from you. Never carry air bag (inflator) module by wires or connector on the side of the module. In case of an accidental deployment, the bag will then deploy with minimal chance of injury.
- As the live side-air bag (inflator) module must be kept with its bag (trim cover) facing up while being stored or left standing. This is necessary so that a free space is provided to allow the air bag to expand in the unlikely event of accidental deployment.
- Observe "Precautions on Handling and Storage of Air Bag System Components: " for handling and storing it. Otherwise, personal injury may result.

**⚠ CAUTION**

Do not damage the sleeve. Otherwise, the side-air bag cannot be correctly installed to seat back.

**Installation**

- 1) Confirm sleeve (1) is surely installed in side-air bag (inflator) module.
- 2) Tighten sleeve lock nut (2) to specified torque.

**Tightening torque**

**Sleeve lock nut (a): 2.5 N·m (0.25 kgf·m, 2.0 lb-ft)**

- 3) Install new clip to seat back.

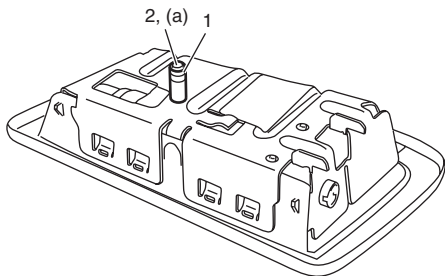

I4RS0A820073-02

- 4) Connect side-air bag (inflator) module connector (1) securely as shown in figure.
  - a) Connect connector.
  - b) Lock connector with lock button (2).

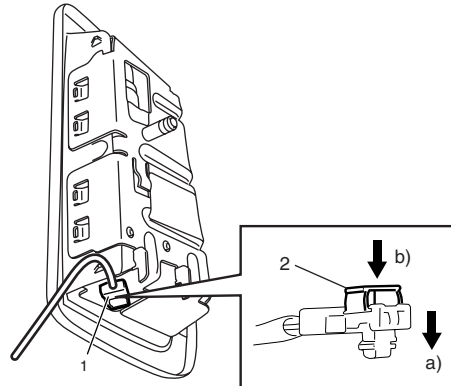

I4RS0A820070-01

- 5) Insert claw (1) of side-air bag (inflator) module on installation hole (2).
- 6) Push side-air bag (inflator) module into clip (3) with specified force.

**Side-air bag (inflator) module installation force**  
**Pushing force: 180 N**

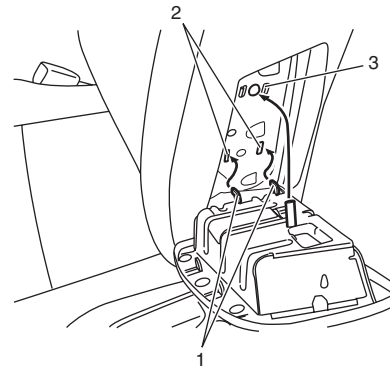

I4RS0A820074-02

## Specifications

### Tightening Torque Specifications

S5JB0A8207001

Fastening part	Tightening torque			Note
	N·m	kgf·m	lb·ft	
SDM bolt	6	0.6	4.5	☞
Driver air bag (inflator) module mounting bolt	9	0.9	6.5	☞
Passenger air bag (inflator) module attaching bolt	23	2.3	16.5	☞
Sleeve lock nut	2.5	0.25	2.0	☞
Side curtain-air bag (inflator) module bolts	10	1.0	7.5	☞
Forward-sensor mounting bolt	11	1.1	8.0	☞
Side-sensor bolt	11	1.1	8.0	☞

#### NOTE

The specified tightening torque is also described in the following.  
**“Air Bag System Components, Wiring and Connectors Location: ”**

#### Reference:

For the tightening torque of fastener not specified in this section, refer to “Fastener Information: in Section 0A”.

## Special Tools and Equipment

### Use of Special Tools

S5JB0A8208001

#### **▲ WARNING**

To avoid deployment when troubleshooting the air bag system, do not use electrical test equipment such as a battery powered or AC powered voltmeter, ohmmeter, etc., or any type of electrical equipment other than that specified. Do not use a non-powered probe type tester.

**Instructions must be followed carefully, otherwise personal injury may result.**

You should be familiar with the tools listed under the heading “Special Tool”. You should be able to measure voltage and resistance. You should be familiar with proper use of a scan tool such as Air Bag Driver / Passenger Load Tool, Connector Test Adapter Kit and the Digital Multimeter.

#### Special tool

**(A): 09932-76010 (Connector Test Adapter Kit)**

This must be used whenever a diagnostic procedure requests checking or probing a terminal.

Using the appropriate adapter in the special tool will ensure that no damage to the terminal will occur from the multimeter probe, such as spreading or bending.

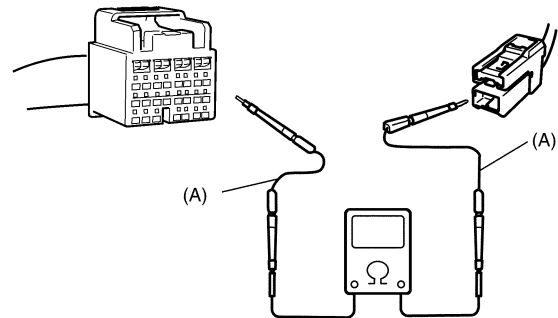

I5JB0A820107-01

The adapter (1) will also give an idea of whether or not contact tension is sufficient, helping to find an open or intermittent open due to poor terminal contact. An SDM short bar release tool (2) is included in the connector test adapter kit. Inserting it into the SDM connector (3) will release the shorting bar.

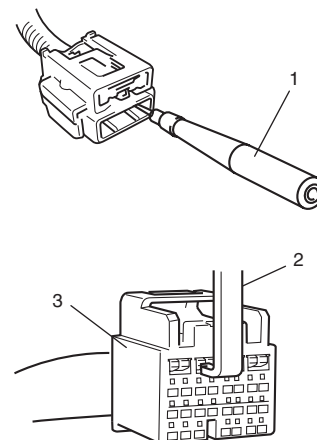

I5JB0A820108-01

## 9A-7 Wiring Systems:

3) Terminals in one connector (Broken line) (B15)/Terminals in different connectors (B14, B16)

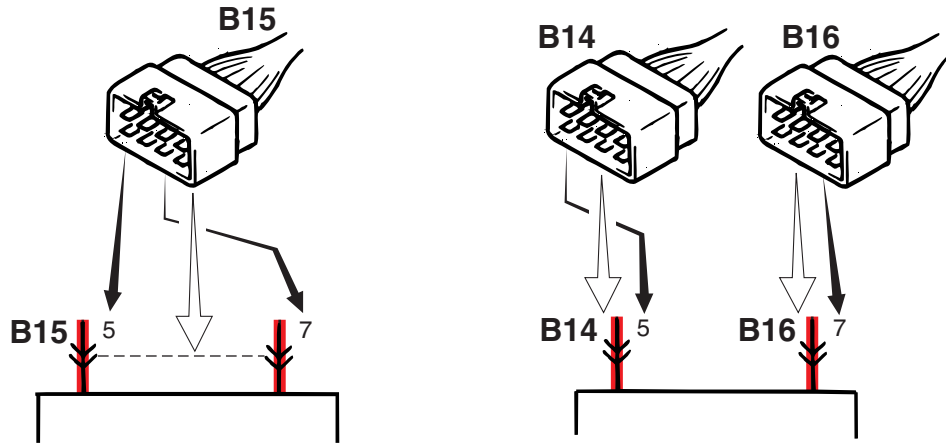

I2RH01910904-01

4) Joint connector (J/C)

- The joint connector (J/C) connects several different wires with the same wire color at one place instead of connecting them by welding or caulking one by one. It is not an ordinary connector but a part of the continuous wire in the harness.

### Example

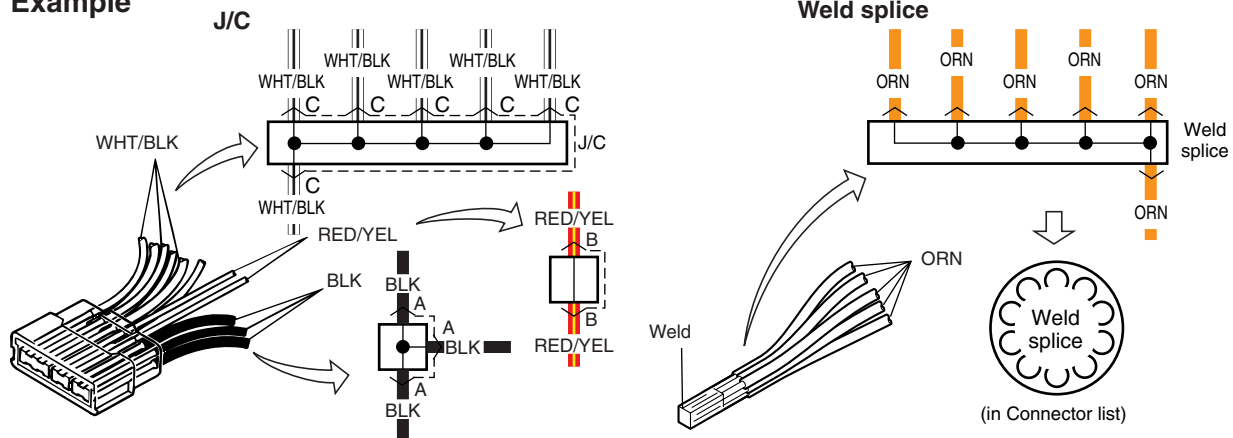

I4RS0A910902-01

**B: A/C wire / F: Console wire / G: Instrument panel harness / Q: A/B wire (RHD)**

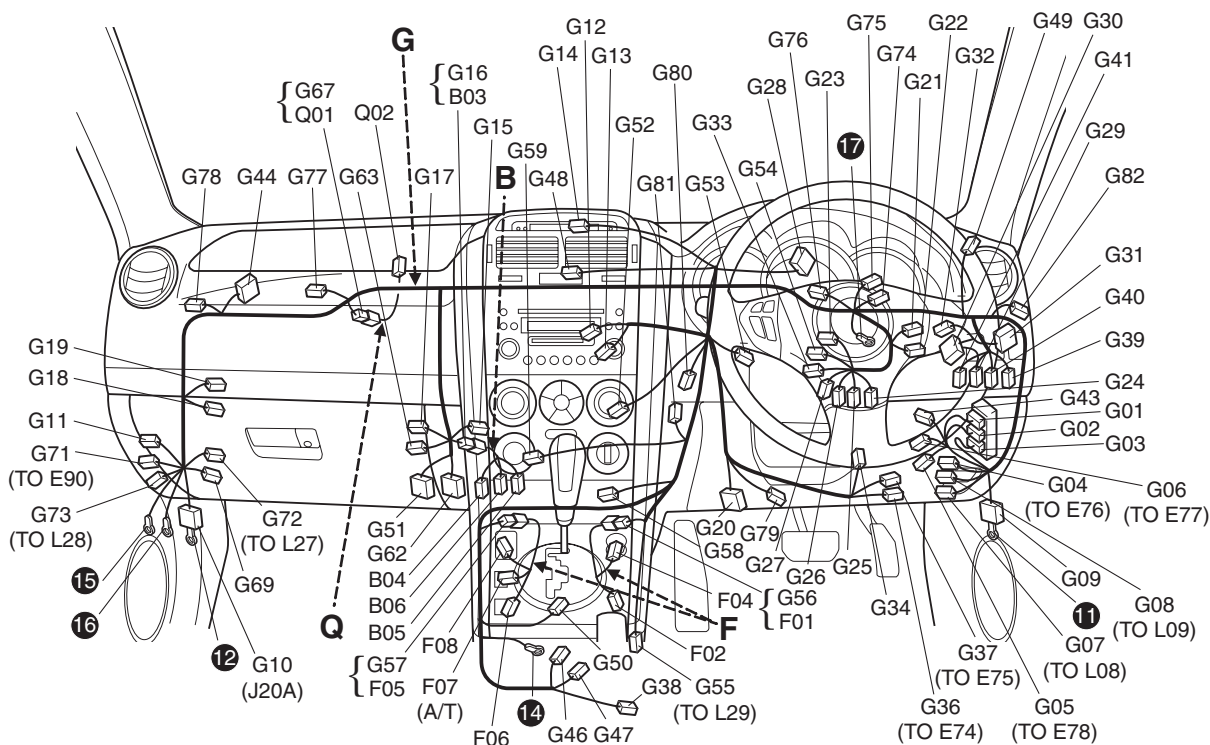

15JB0A910909-05

**B: A/C wire**

No./Color	Connective position	No./Color	Connective position
B03/N	Instrument panel harness (To G16)	B05/YEL	Fresh/Recircle actuator
B04/YEL	Temperature control actuator	B06/YEL	Mode selecting actuator

**F: Console wire**

No./Color	Connective position	No./Color	Connective position
F01/N	Instrument panel harness (To G56)	F06/GRN	Seat heater switch (Passenger side)
F02/GRN	Seat heater switch (Driver side)	F07/N (A/T)	A/T mode select switch
F04/N	Cigar lighter (ACC socket #3)	F08/N	ACC socket #2
F05/N	Instrument panel harness (To G57)		

**G: Instrument panel harness**

No./Color	Connective position	No./Color	Connective position
G01/N	J/B	G38/N	Parking brake switch
G02/N	J/B	G39/ORN	HLC switch
G03/N	J/B	G40/N	Headlight beam leveling switch
G04/N	Main harness (To E76)	G41/GRY	ILL cancel switch
G05/GRY	Main harness (To E78)	G43/BLK	Diagnosis connector #4
G06/YEL	Main harness (To E77)	G44/N	Smart ECM
G07/N	Floor harness (To L08)	G46/YEL (With side A/B, curtain A/B system)	A/B SDM
G08/BLU	Floor harness (To L09)	G47/YEL (Without side A/B, curtain A/B system)	A/B SDM
G09/N	J/C	G48/ORN	Hazard switch
G10/N (J20A)	J/C	G49/N	Sunlight sensor
G11/N	Audio antenna	G50/N	A/T shift lever
G12/BLU	Audio	G51/N	Auto leveling control module
G13/N	Navigation	G52/GRY	Auto A/C

# 9A-41 Wiring Systems:

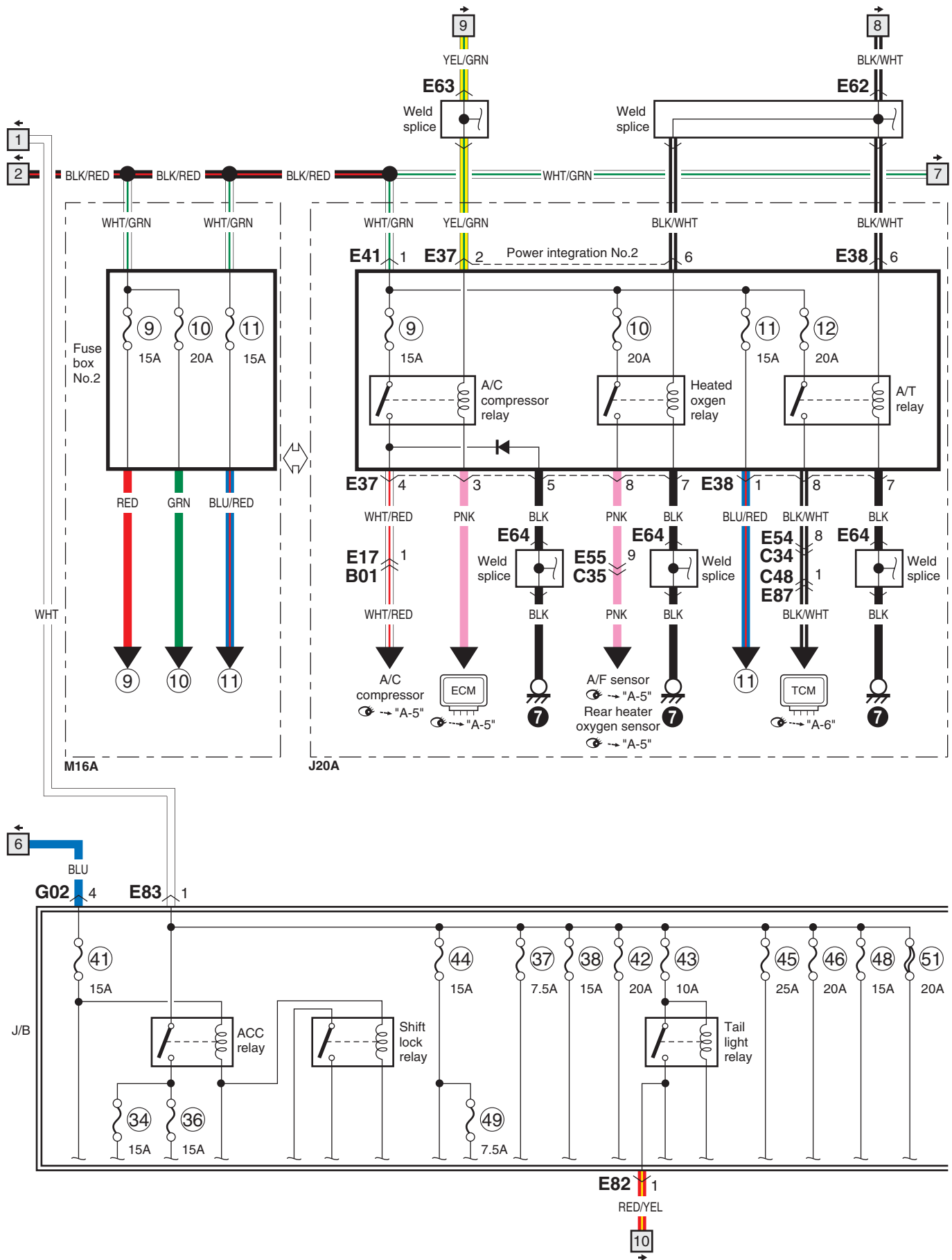

A-4 Cooling System Circuit Diagram

S5JB0A910E004

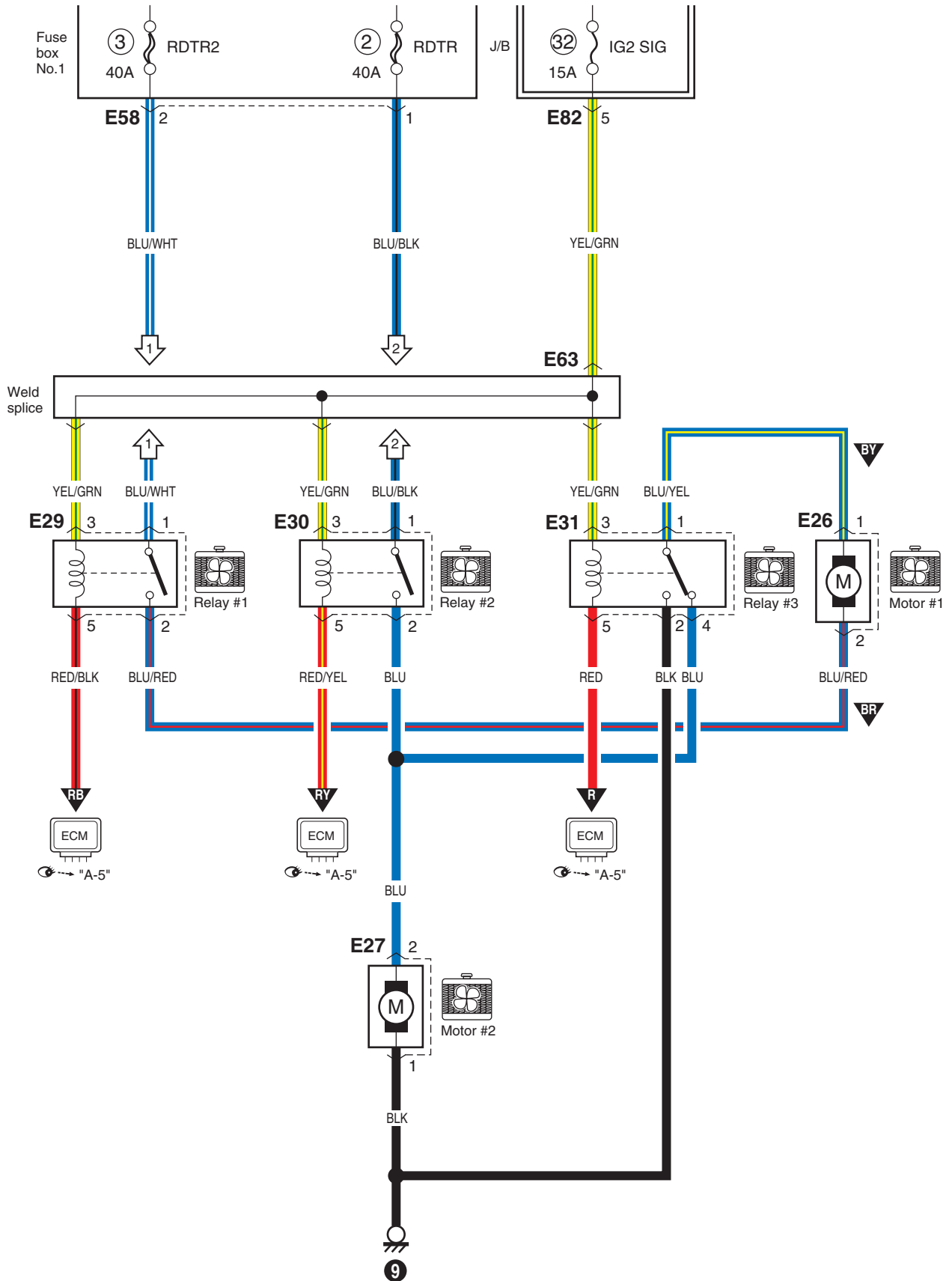

- (A) RHD
- (B) LHD
- (C) 2-Action
- (D) 1-Action

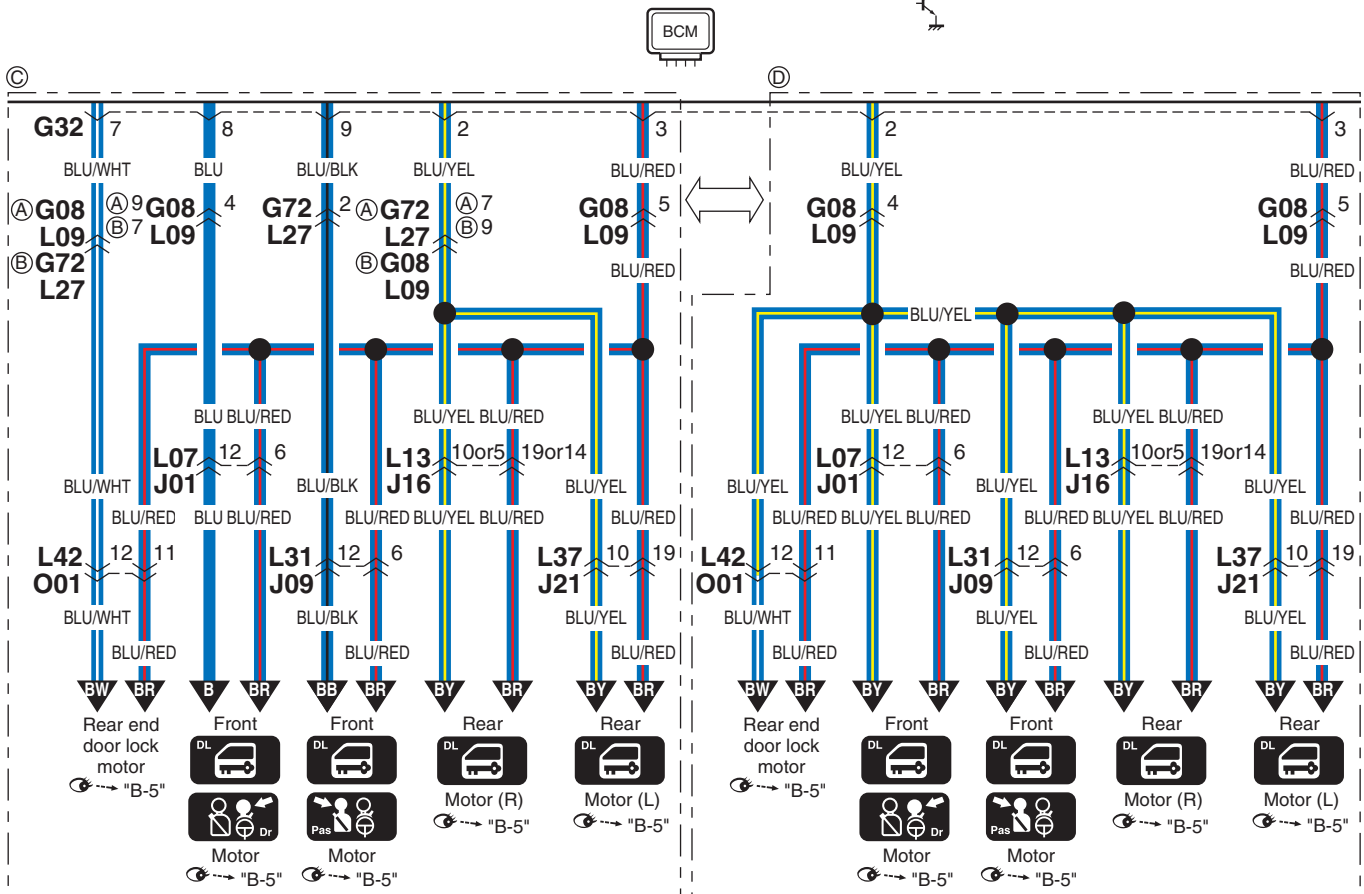
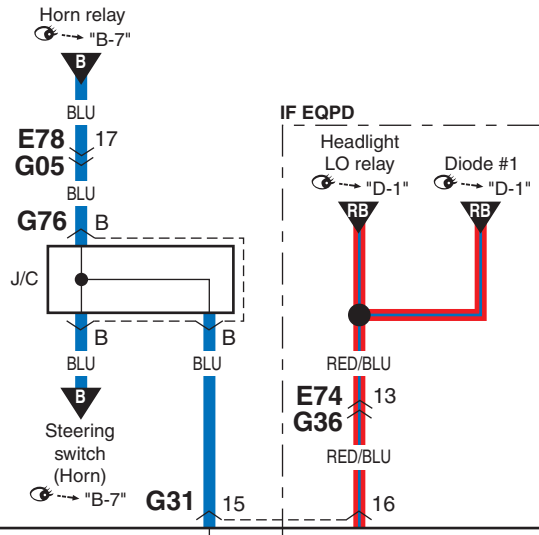





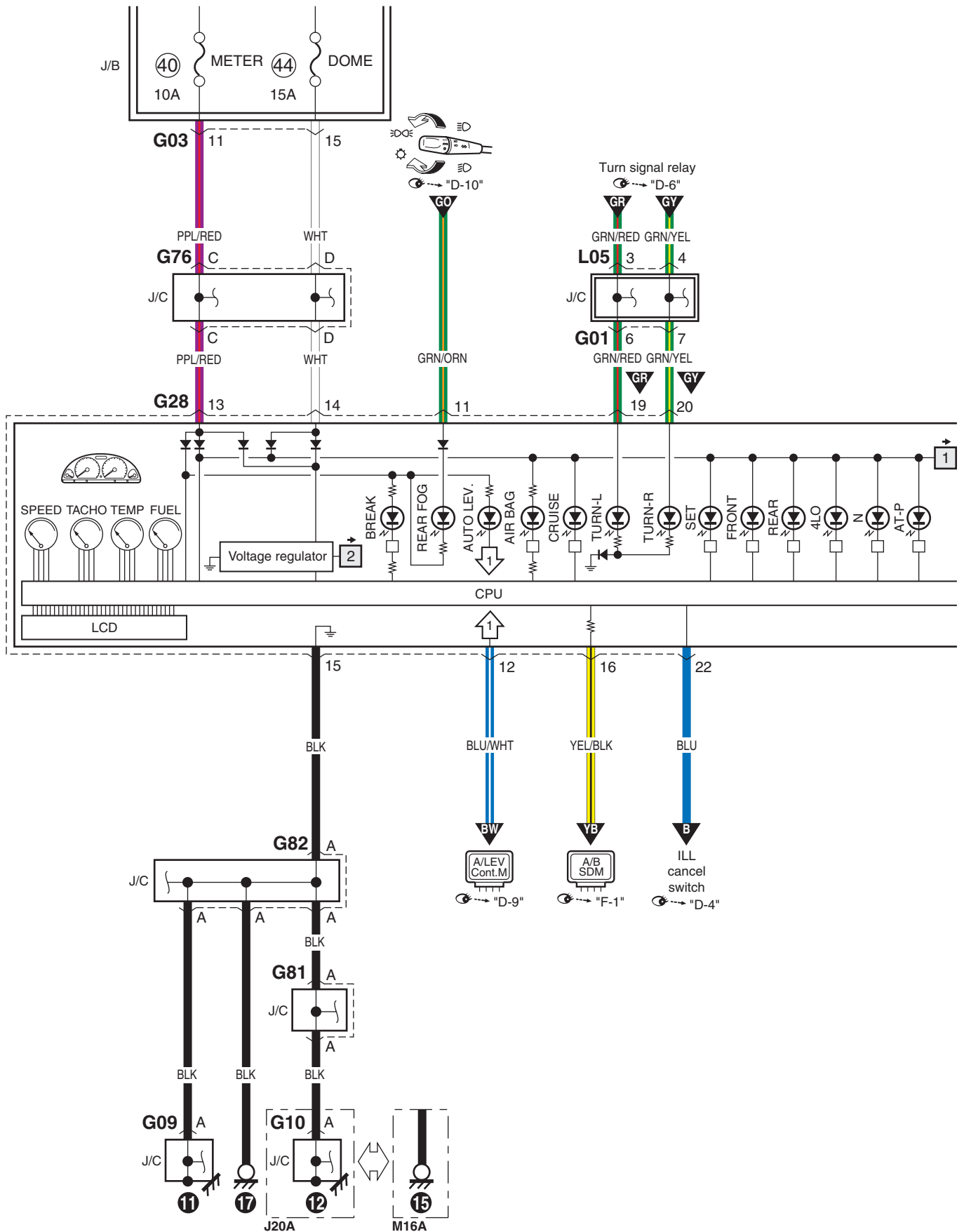



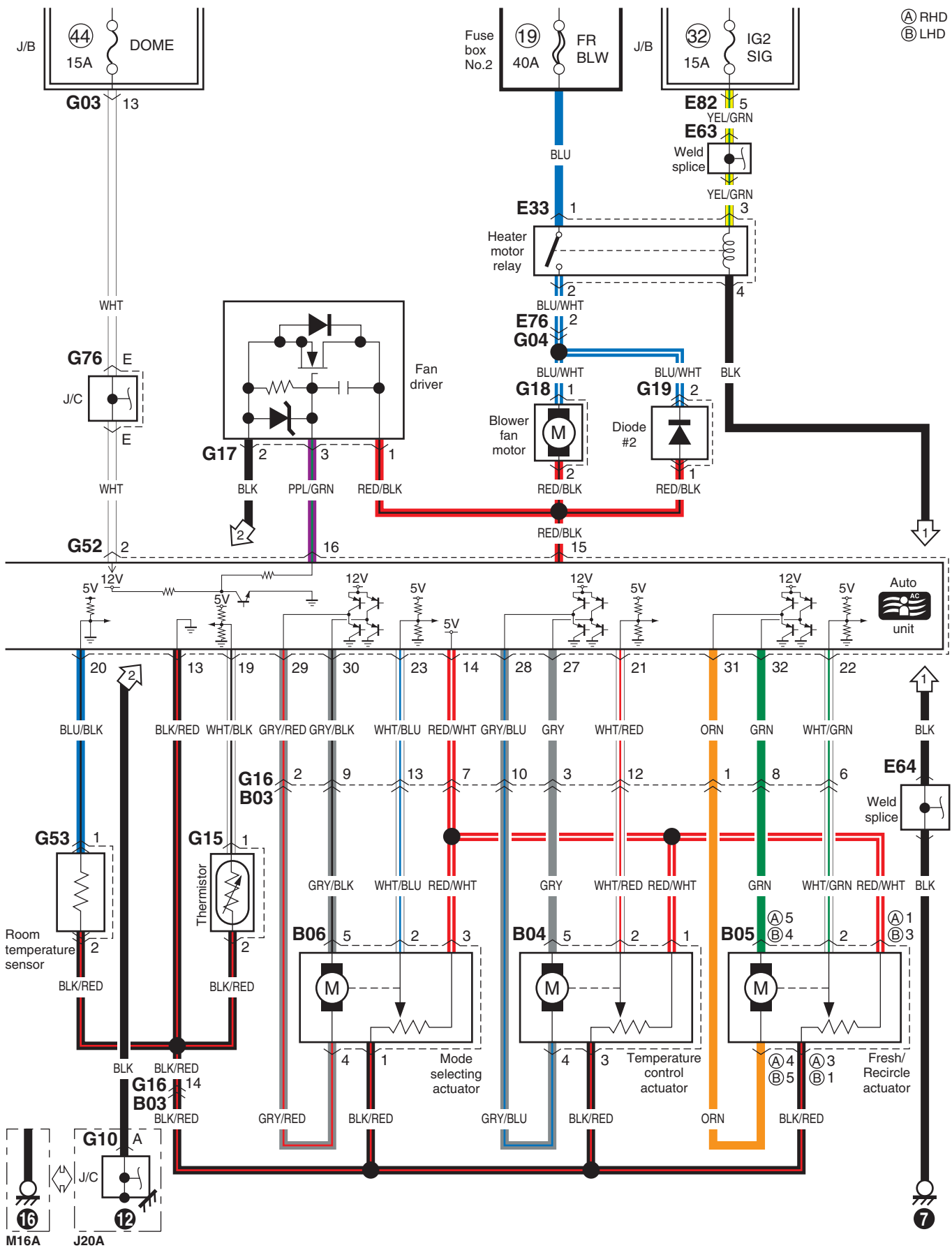

C-1 Combination Meter Circuit Diagram

S5JB0A910E017

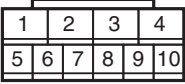
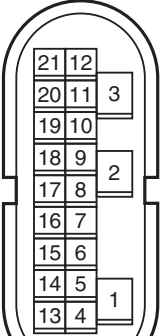

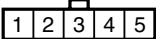
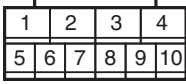

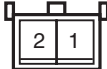
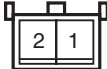

9A-109 Wiring Systems:



<p>J17</p>  <p>MCONF020008-01</p>	<p>J18</p>  <p>MCONF020236-01</p>	<p>J19</p>  <p>MCONF050021-01</p>	<p>J20</p>  <p>MCONF100061-01</p>	<p>J21 (TO L37)</p>  <p>MCONM210001-01</p>	<p>J22</p>  <p>MCONF020008-01</p>
<p>J23</p>  <p>MCONF020236-01</p>	<p>J24</p>  <p>MCONF050001-01</p>	<p>J25</p>  <p>MCONF100061-01</p>	<p>J26</p>  <p>MCONM020018-01</p>	<p>J27</p>  <p>MCONM020016-01</p>	<p>J28</p>  <p>MCONM020018-01</p>
<p>J29</p>  <p>MCONM020016-01</p>	<p>J31</p>  <p>MCONM020049-01</p>	<p>J32</p>  <p>MCONM020049-01</p>			

**K Connector**

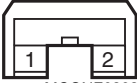
S5JB0A910F005

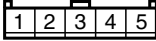
<p>K01</p>  <p>MCONF100062-01</p>	<p>K02</p>  <p>MCONF030102-01</p>	<p>K03</p>  <p>MCONF030102-01</p>	<p>K04</p>  <p>MCONF020233-01</p>	<p>K05</p>  <p>MCONF020233-01</p>	<p>K06</p>  <p>MCONF100054-01</p>
<p>K07</p>  <p>MCONF050021-01</p>					

Interior Light Symptom Diagnosis

S5JB0A9204007

NOTE

- Use of SUZUKI scan tool makes it easy to check whether a faulty condition is on the input side or output side of BCM. For checking procedure, refer to “Diagnosis Using Output Test Function of SUZUKI Scan Tool” under “Scan Tool Data: in Section 10B”.
- Check each part in the order from the top of the following list.

Condition	Possible cause	Correction / Reference Item
<b>Dome light does not light up</b>	Bulb blown	Replace bulb.
	Circuit fuse blown	Replace fuse and check for short circuit.
	Dome light switch faulty	Check dome light switch.
	Door switch faulty	Check door switch referring to “Door Switch (Front / Rear / Rear End Door) Inspection: in Section 9C”.
	Wiring or grounding	Repair circuit.
	BCM faulty	Replace after making sure that none of above parts is faulty.
<b>Luggage compartment light (if equipped) does not light up</b>	Bulb blown	Replace bulb.
	Back door switch faulty	Check switch referring to “Door Switch (Front / Rear / Rear End Door) Inspection: in Section 9C”.
	Wiring or grounding faulty	Repair circuit.

Auto-On Headlight Operation Inspection (If Equipped)

S5JB0A9204020

- 1) Turn ignition switch to ON position and then turn lighting switch to “AUTO” position.
- 2) Release parking brake lever.
- 3) Check headlights for operation as follows. If headlights do not turn ON or OFF, go to “Auto-On Headlight System Symptom Diagnosis (If Equipped): ”.
  - a) Cover auto-on headlight sensor by hand and check that headlights light up then.
  - b) Light over auto-on headlight sensor vertically with on incandescent lamp of approx. 100 W apart from about 100 mm (3.94 in.) (1) and check that headlights go off then.
  - c) In the state as described in Step a), pull up parking brake lever and check that headlights go off then.

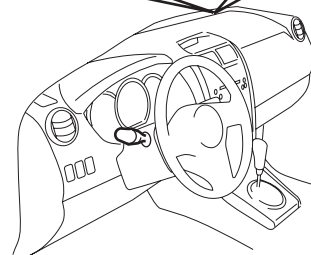
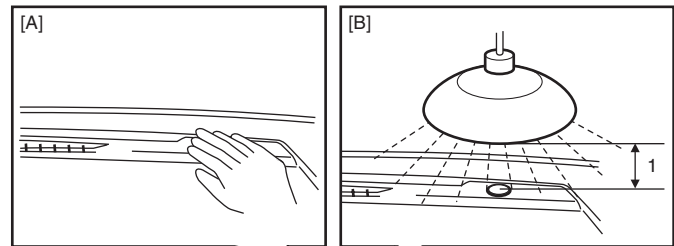

I5JB0A920013-02

[A]: Fig. for Step a) [B]: Fig. for Step b)

DRL Operation Inspection (If Equipped)

S5JB0A9204013

- 1) Confirm that lighting switch is in OFF position.
- 2) Confirm that dimmer and passing switch is in low beam position.
- 3) Check DRL for operation as follows.
  - a) Turn ignition switch to ON position and check headlights remain OFF.
  - b) Start engine and run it at idle speed. Check headlights turn ON at low beam.
  - c) Switch dimmer and passing switch to high beam position and check headlights remain tuning ON at low beam.
- 4) If a malfunction is found, go to “DRL System Symptom Diagnosis (If Equipped): ”.

### Auto-On Headlight Sensor Inspection (If Equipped)

S5JB0A9206031

- 1) Disconnect negative (-) cable at battery.
- 2) Remove auto-on headlight sensor (1) located on the passenger side of the dashboard (2). Be careful not to damage the sensor (1) and dashboard by using rag (3).

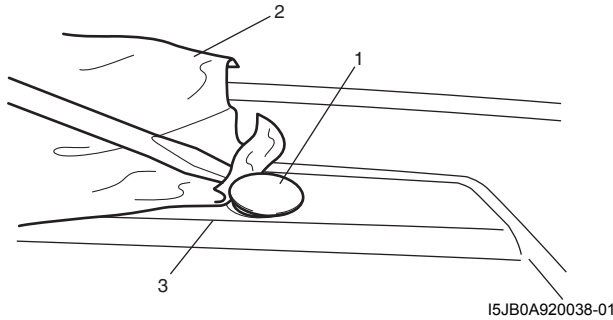

- 3) Measure voltage between white wire terminal and black wire terminal at the following condition.  
If measured voltage is out of specification, replace sensor.

### Auto-on headlight sensor voltage specifications

Cover the sensor lens with hand: 0.4 V

Light the sensor lens with incandescent lamp  
100 W: 3 – 4.5 V

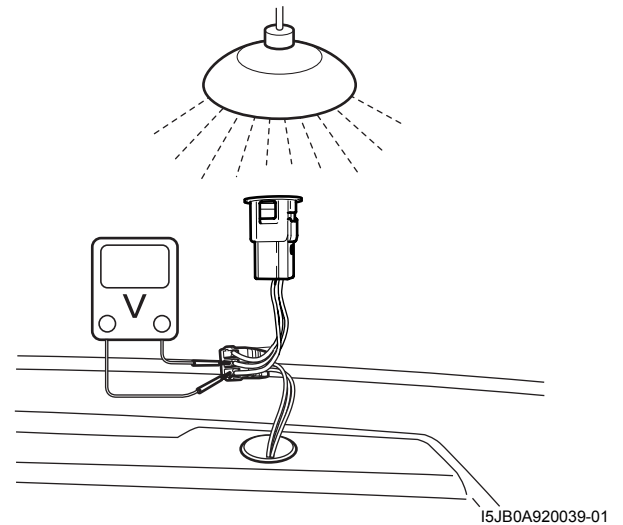

## Specifications

### Tightening Torque Specifications

S5JB0A9207001

Fastening part	Tightening torque			Note
	N·m	kgf·m	lb·ft	
Height sensor bolt	8	0.8	6.0	☞
Height sensor nut	8	0.8	6.0	☞

### Reference:

For the tightening torque of fastener not specified in this section, refer to “Fastener Information: in Section 0A”.

**Removal**

- 1) Disconnect negative cable at battery.
- 2) Remove driver side instrument panel under cover (1) and passenger side instrument panel under cover (2).

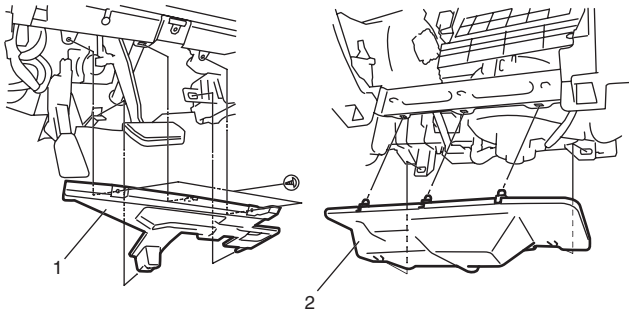

I5JB0A930011-02

- 3) Disable air bag system referring to “Disabling Air Bag System: in Section 8B”.
- 4) Remove steering column hole cover (1).
- 5) Turn steering wheel to remove steering column cover screws (3).
- 6) Remove steering column covers (2).

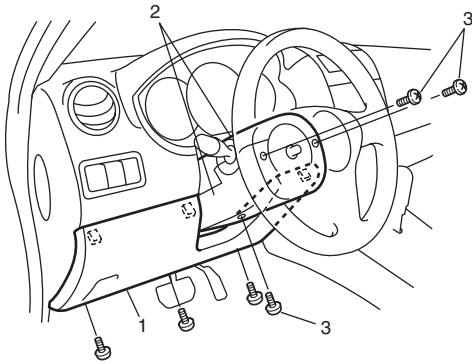

I5JB0A940020-02

- 7) Remove glove box (1).
- 8) Remove hood latch release lever (2).

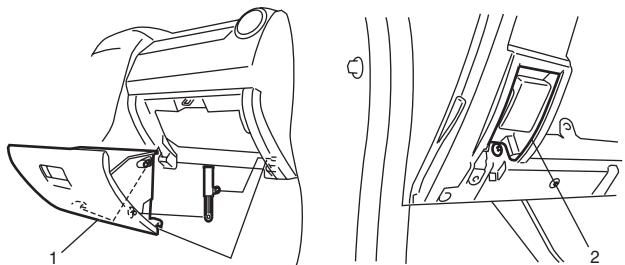

I5JB0A930012-02

- 9) Remove console box referring to “Console Box Components: in Section 9H”.
- 10) Remove front pillar trims (1) front side sill scuffs (2) and dash side trims (3).

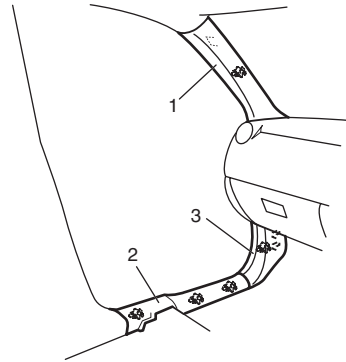

I5JB0A930013-02

- 11) Disconnect instrument panel harness connectors, inside air temperature sensor duct and antenna cable instrument panel removal.
- 12) Remove steering column mounting referring to “Steering Column Assembly Removal and Installation: in Section 6B”.
- 13) Remove instrument panel ground wire.
- 14) Remove instrument panel mounting bolts (1).
- 15) Remove instrument panel (2) with steering support member and instrument panel harness.

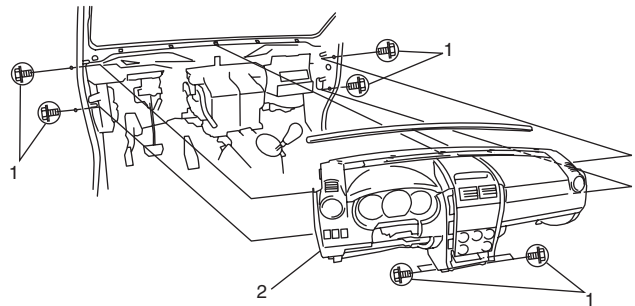

I5JB0A930014-01

### Washer Linked Circuit

- 1) Make sure that front wiper switch is at "OFF" position.
- 2) Connect battery positive (+) terminal to terminal "5" and its negative (-) terminal to terminal "2".
- 3) Connect voltmeter positive lead to terminal "4" and its negative lead to terminal "2".
- 4) When front washer switch is ON, check that voltage changes as shown in figure.  
If check result is not satisfied, replace switch.

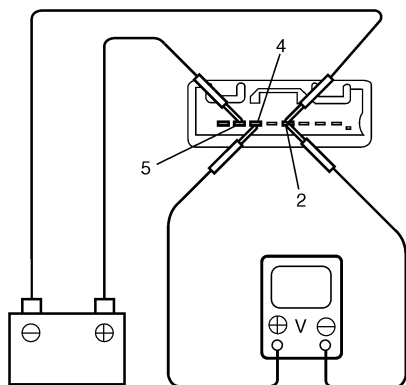
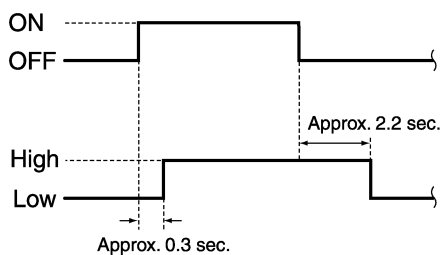

I4RS0B940012-01

### Rear Wiper and Washer Switch Removal and Installation

S5JB0A9406010

For removal and installation, refer to "Windshield Wiper and Washer Switch Removal and Installation: ".

### Rear Wiper and Washer Switch Inspection

S5JB0A9406011

Check for continuity between terminals at each switch position. If check result is not as specified, replace switch.

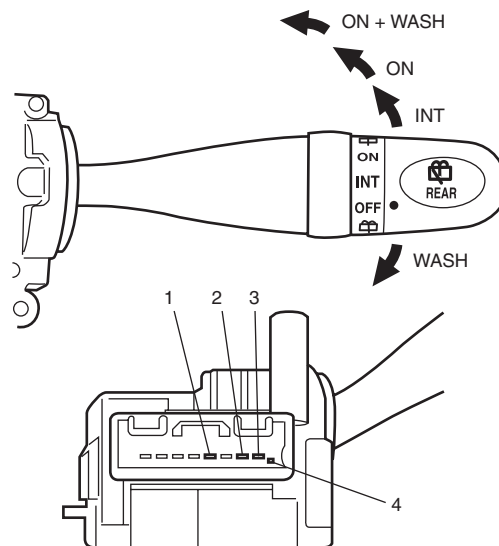

Position	Terminal	1	2	3	4
OFF					
INT		○			○
ON		○		○	
ON + WASH		○	○	○	
WASH		○	○		

I4RS0B940013-03

### Rear Wiper Relay Removal and Installation

S5JB0A9406012

#### Removal

- 1) Disconnect negative (-) cable at battery.
- 2) Remove rear end door trim from rear end door referring to "Rear End Door Lock Assembly Removal and Installation: in Section 9F".
- 3) Remove rear wiper relay (1).

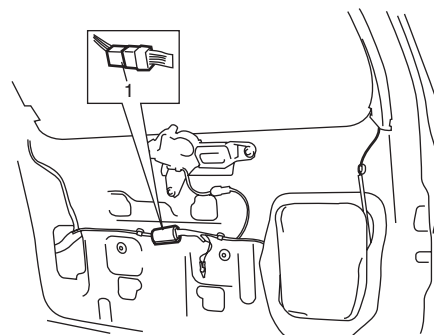

I5JB0A940021-01

#### Installation

Reverse removal procedure for installation.

## 9E-15 Glass / Windows / Mirrors:

- Install front door trim.

### Front door trim attaching order

(1) → (2) → (3) → (4) → (5) → (6) → (7) → (8)

[A]

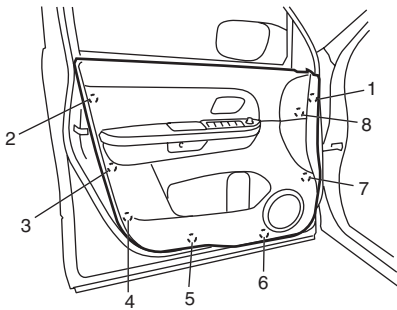

[B]

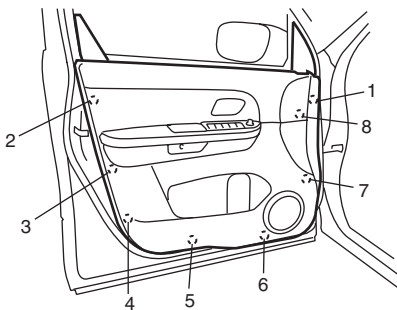

I5JB0A950015-02

[A]: 5 door model

[B]: 3 door model

## Front Door Window Regulator Removal and Installation

S5JB0A9506004

### Removal

- 1) Remove door glass referring to "Front Door Glass Removal and Installation: ".
- 2) Disconnect power window motor lead wire at coupler.
- 3) Remove regulator mounting screws (1), and then remove front door window regulator (2).

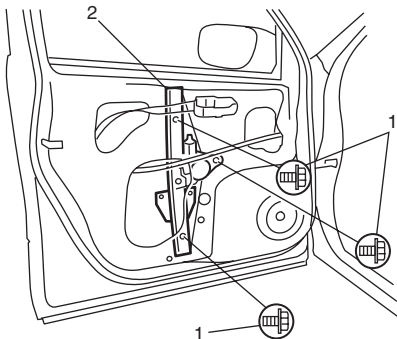

I5JB0A950016-01

### Installation

Reverse removal procedure noting the following instruction.

- Apply grease to sliding portions of window regulator.  
: Grease 99000-25010
- Tighten front door window regulator attaching screws.

### Front door window regulator screw tightening order

(a) → (b) → (c)

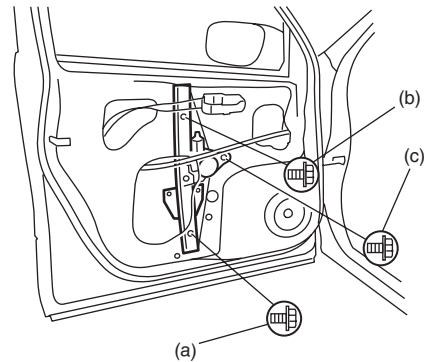

I5JB0A950017-01

## Front Door Window Regulator Inspection

S5JB0A9506005

Check the following parts for wear, damage, smooth operation and lubrication:

- Check regulator sliding and rotating parts.
- Check rollers.

**For front door**

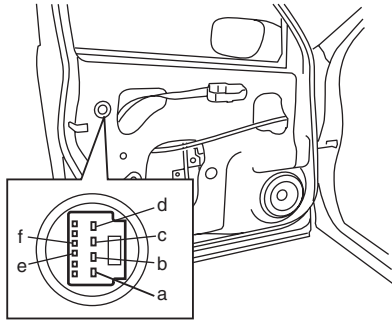

[A]

Terminals	a	d
Lock → Unlock	⊕	⊖
Unlock → Lock	⊖	⊕

Terminals	f	g
Lock		
Unlock	○	○

[B]

Right side switch terminals	a	b	c	d
Left side switch terminals	c	d	a	b
Lock → Unlock	⊕	⊖		
Unlock → Lock	⊖	⊕		
Deadlock → Unlock			⊕	⊖
Lock → Deadlock			⊖	⊕

Terminals	f	g
Lock		
Unlock	○	○

I5JB0A960009-01

[A]: Without deadlock	[B]: With deadlock
-----------------------	--------------------

**For rear door**

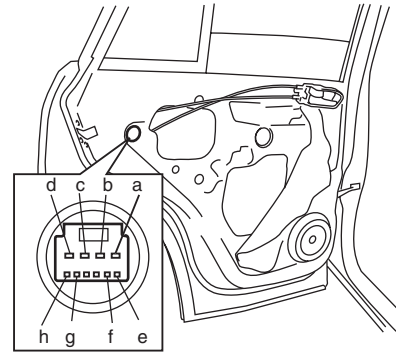

[A]

Terminals	a	d
Lock → Unlock	⊕	⊖
Unlock → Lock	⊖	⊕

Terminals	f	g
Lock		
Unlock	○	○

[B]

Right side switch terminals	c	d	a	b
Left side switch terminals	a	b	c	d
Lock → Unlock	⊕	⊖		
Unlock → Lock	⊖	⊕		
Deadlock → Lock			⊕	⊖
Lock → Deadlock			⊖	⊕

Right side switch terminals	g	h
Left side switch terminals	e	f
Lock		
Unlock	○	○

I5JB0A960010-01

[A]: Without deadlock	[B]: With deadlock
-----------------------	--------------------

### Sliding (Sun) Roof Motor Removal and Installation

S5JB0A9906006

#### Removal

- 1) Remove spot lamp assembly from head lining.
- 2) Disconnect coupler (3) and remove sliding roof motor (1) by removing 2 bolts (2).

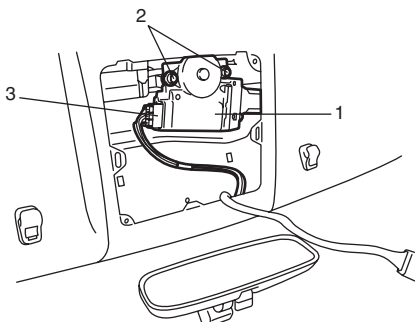

I5JB0A990006-01

#### Installation

For installation, reverse removal procedure, noting the following points.

- Connect coupler to sliding roof motor securely.
- Initialize sliding roof position data referring to “How to reactivate the system to prevent being pinched by the sunroof” in Sunroof section of Owner’s manual.

### Sliding (Sun) Roof System Circuit and Motor Inspection

S5JB0A9906007

- 1) Check that sliding roof switch is in good condition referring to “Sliding (Sun) Roof Switch Inspection: ”.
- 2) Connect connector to sliding roof switch.
- 3) Disconnect connector from sliding roof motor.
- 4) Measure voltage and resistance between each terminals of sliding roof motor connector (1).  
If each voltage and/or resistance are within specified value, sliding roof system circuit is in good condition and proceed next step.  
If each voltage and/or resistance are out of specified value, repair sliding roof system circuit.

#### Sliding roof system circuit specification with connector disconnected

Measurement terminal	Measurement condition	Reference value
5(+)-7(-)	Ignition switch turned OFF and ON	10 - 14 V
8(+)-7(-)	Ignition switch turned ON	10 - 14 V
9-7	Ignition switch turned OFF and sliding roof switch from OFF to “SLIDE OPEN”	Infinity ↓ 0 - 1 Ω

Measurement terminal	Measurement condition	Reference value
10 - 7	Ignition switch turned OFF and sliding roof switch from OFF to “TILT UP”	Infinity ↓ 0 - 1 Ω
7 - vehicle body ground	Ignition switch turned OFF	0 - 1 Ω

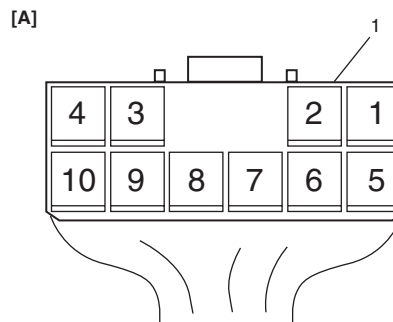

I5JB0A990007-01

[A]: Viewed from harness side

- 5) Connect connector to sliding roof motor (1).
- 6) Measure each voltage between terminals of sliding roof motor connector (2) with ignition switch ON. If each voltage is out of specified value, replace sliding roof motor.

#### Sliding roof motor out put voltage

Measurement terminal	Measurement condition	Reference value
9(+)-7(-)	Sliding roof switch from OFF to “SLIDE OPEN”	10 - 14 V (OFF) ↓ 0 V (“SLIDE OPEN”)
10(+)-7(-)	Sliding roof switch from OFF to “TILT UP”	10 - 14 V (OFF) ↓ 0 V (“TILT UP”)

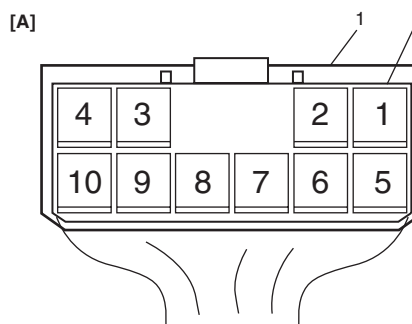

I5JB0A990008-01

[A]: Viewed from harness side

Side Body

5 door model

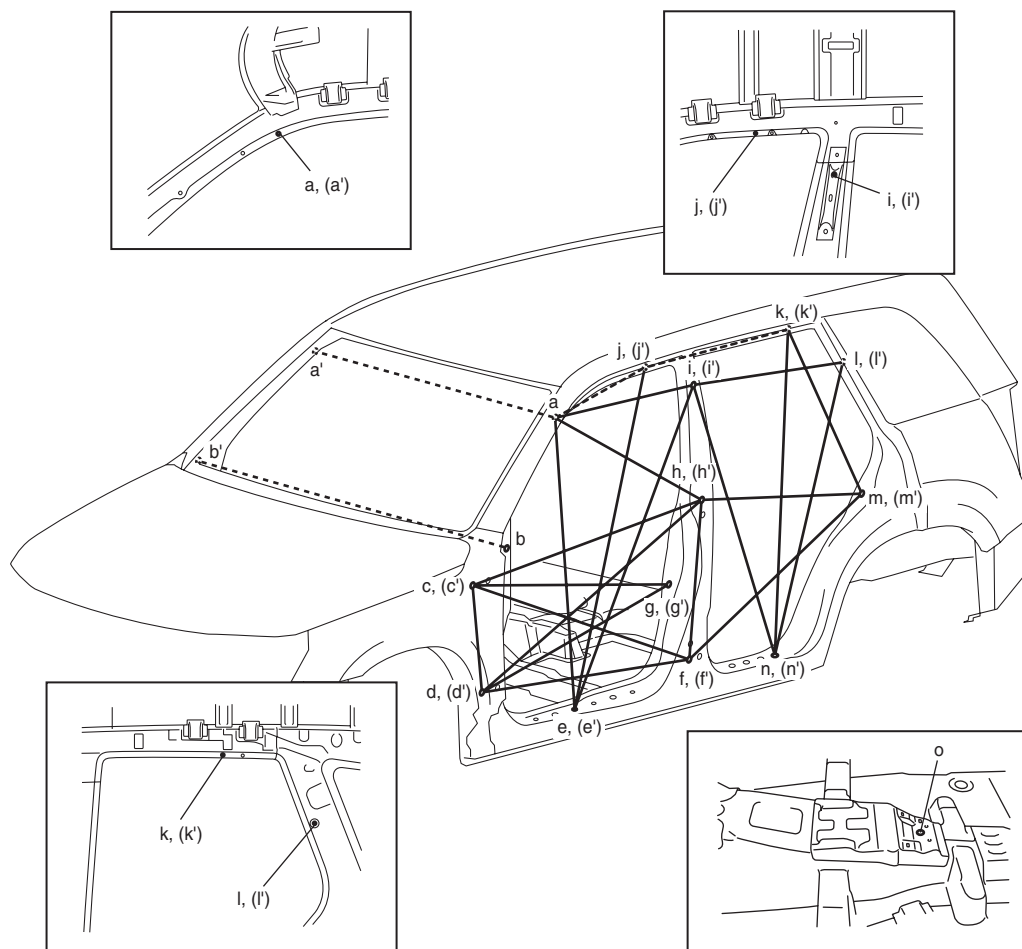

15JB0A9B0006-02

a (a'). Jig hole (φ 8 mm)	f (f'). Rear door lower hinge installation front side hole	k (k'). Jig hole (φ 8 mm)
b (b'). Steering support member installation hole	g (g'). Front door switch installation hole	l (l'). Rear quarter upper trim installation hole
c (c'). Front door upper hinge installation front side hole	h (h'). Rear door upper hinge installation upper side hole	m (m'). Rear door switch installation hole
d (d'). Front door lower hinge installation front side hole	i (i'). Jig hole (φ 8 mm)	n (n'). Rear side sill scuff installation hole
e (e'). Front side sill scuff installation hole	j (j'). Jig hole (φ 8 mm)	o. Jig hole (φ 10 mm)

Hole to hole distance

<b>a-a': 1248 mm (49.13 in.)</b>	<b>d(d')-f(f)': 1085 mm (42.72 in.)</b>	<b>i-i': 1302 mm (51.26 in.)</b>
<b>a(a')-e(e)': 1093 mm (43.03 in.)</b>	<b>d(d')-g(g)': 1081 mm (42.56 in.)</b>	<b>i(i')-n(n)': 1063 mm (41.85 in.)</b>
<b>a(a')-h(h)': 731 mm (28.78 in.)</b>	<b>d(d')-h(h)': 1226 mm (44.33 in.)</b>	<b>i(i')-l(l)': 833 mm (32.80 in.)</b>
<b>a(a')-i(i)': 573 mm (22.56 in.)</b>	<b>e-e': 1567 mm (61.69 in.)</b>	<b>j-j': 1205 mm (47.44 in.)</b>
<b>a(a')-j(j)': 340 mm (13.39 in.)</b>	<b>e(e')-i(i)': 1248 mm (49.13 in.)</b>	<b>j(j')-k(k)': 753 mm (29.65 in.)</b>
<b>b-b': 1506 mm (59.29 in.)</b>	<b>e(e')-j(j)': 1239 mm (48.78 in.)</b>	<b>k-k': 1190 mm (46.85 in.)</b>
<b>c-c': 1594 mm (62.76 in.)</b>	<b>f-f)': 1621 mm (63.82 in.)</b>	<b>k(k')-m(m)': 713 mm (28.07 in.)</b>
<b>c (c')-d(d)': 345 mm (13.58 in.)</b>	<b>f(f')-h(h)': 391 mm (15.39 in.)</b>	<b>k(k')-n(n)': 1171 mm (46.10 in.)</b>
<b>c(c')-f(f)': 1123 mm (44.21 in.)</b>	<b>f(f')-m(m)': 979 mm (38.54 in.)</b>	<b>l-l': 1329 mm (52.32 in.)</b>
<b>c(c')-g(g)': 1149 mm (45.24 in.)</b>	<b>g-g': 1472 mm (57.95 in.)</b>	<b>l(l')-n(n)': 1069 mm (42.09 in.)</b>
<b>c(c')-h(h)': 1148 mm (45.20 in.)</b>	<b>h-h': 1580 mm (62.20 in.)</b>	<b>m-m': 1476 mm (58.11 in.)</b>
<b>d-d': 1630 mm (64.17 in.)</b>	<b>h(h')-m(m)': 859 mm (33.82 in.)</b>	<b>n-n': 1567 mm (61.69 in.)</b>

NOTE

Use jig hole (o) as datum point to check symmetry of body structure.

9L-8 Paint / Coatings:

Rear Structure Panel (5 Door Model)

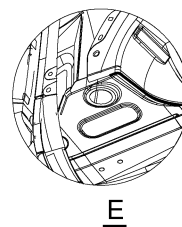
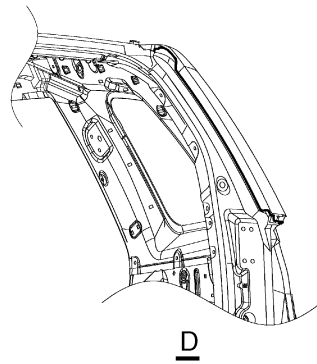
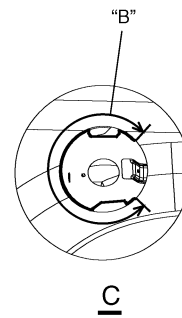
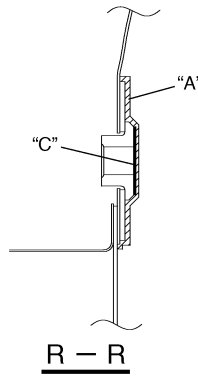
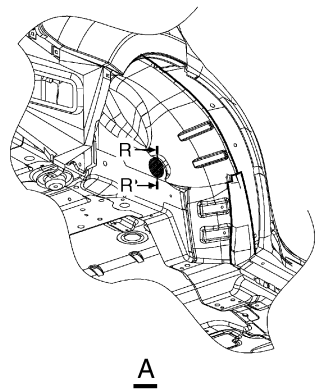
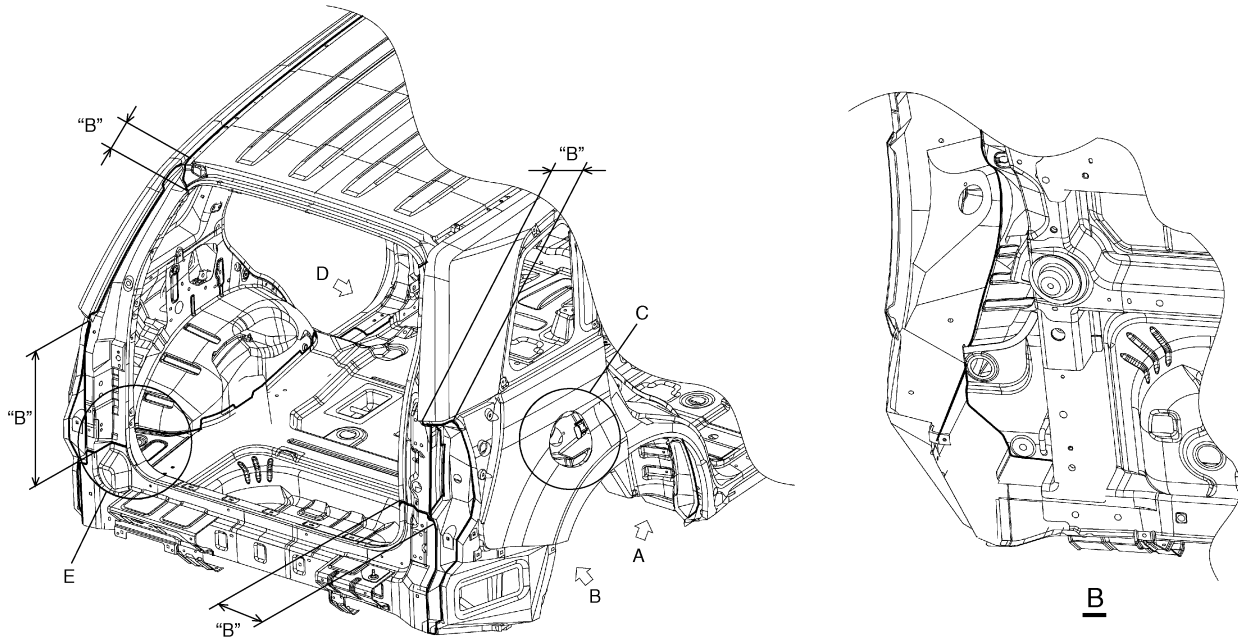

"A": Apply sealant.	"C": Do not apply sealant.
"B": Smooth out sealant with a brush.	

## Components and Functions of Cruise Control System

Component	Function
ECM and electric throttle body assembly	ECM executes centralized control over all functions including setting a constant speed, resuming it, setting coast, cancelling cruise control limiting minimum speed. ECM controls electric throttle valve opening to keep actual vehicle speed at set (target) speed.
MAIN switch	This switch has a momentary contact type button to press cruise control system ON and OFF.
SET/COAST switch	When this switch is pressed (ON) and then released (OFF) while vehicle is running at a speed 40 km/h (25 mile/h) or higher, vehicle speed at that OFF moment is stored in memory and it is maintained (constant cruising). Pressing this switch (ON) continuously during constant cruising keeps slowing down vehicle speed as long as it is ON. When it is released (OFF), vehicle speed at that moment is stored in memory and vehicle starts constant cruising.
RES/ACC switch	When this switch is pressed (ON) during constant cruising, vehicle speed keeps increasing as long as it is ON. When it is released (OFF), vehicle speed at that moment is stored in memory and vehicle starts constant cruising. If vehicle speed is higher than 40 km/h (25 mile/h) after cruise control is cancelled, pressing this switch ON momentarily will resume the speed at which vehicle was running before cancellation.
CANCEL switch	When this switch is pressed (ON), cruise control (throttle valve control) is cancelled.
Wheel speed sensor (vehicle speed signal)	ECM receives speed sensor signal from ABS hydraulic unit / control module through CAN communication and calculates vehicle speed using that signal.
Brake light switch	Brake light switch has 2 contact points. One contact point closes when brake pedal is depressed to light brake light and provides a voltage signal to the ECM. The other contact point (brake pedal position switch) opens when brake pedal is depressed, to shut off power to cruise control of ECM, thereby cancelling cruise control (throttle valve control). This switch is installed to cancel cruise control (constant cruising).
Clutch pedal position switch (M/T vehicle only)	When clutch pedal is depressed, clutch pedal position switch closes and provides a ground signal to ECM. ECM cancels cruise control (throttle valve control) when this signal is inputted.
Transmission range switch (A/T vehicle only)	When selector lever is placed in either "P", "R" or "N" position, transmission range switch closes and provides a ground signal to TCM. TCM transmits signal from transmission range switch to ECM through CAN communication. When ECM receives a signal indicating that selector lever position is "P", "R" or "N", it cancels cruise control (throttle valve control).
TCM	TCM receives the SET signal for the cruise control from ECM through CAN communication. When TCM receives the SET signal from ECM, the gear shift control is performed by using the gear shift map for the cruise control changed from the one for normal gear shift. For details, refer to "Automatic Gear Shift Table: in Section 5A".
"CRUISE" indicator lamp	In the state with ignition switch ON and cruise control system OFF, pressing MAIN switch once and releasing it will activate the cruise control system and ECM will cause indicator lamp to light up.
"SET" indicator lamp	It lights up when cruise control (throttle valve control) is functioning.

Scan Tool Data

Scan tool Data	Condition	Normal condition / reference value
Vehicle Speed	At stop with ignition switch turned ON	0 km/h
Outside air Temp	Reference value is relative to outside air temperature	-40 °C – 70 °C (-40 °F – 158 °F)
Battery Voltage	At specified idle speed after warming up	10 – 14 V
Coolant Temp	At specified idle speed after warming up	80 °C – 100 °C (176 °F – 212 °F)
Engine Speed	Engine idling with no load applied after warming up	Desired idle speed ± 50 rpm
Fuel Consumption	At specified idle speed after warming up	0.0 km/l
Key Reminder Sw	Ignition key inserted in ignition key cylinder	Key in
	Ignition key pulled out from ignition key cylinder	Pulled
Door key Sw	Key cylinder switch of driver side door at lock position	LOCK
	Key cylinder switch of driver side door not turned	Neutral
	Key cylinder switch of driver side door at unlock position	Unlock
Door Lock Sw	Lock side of manual door lock switch pressed	LOCK
	Manual door lock switch not pressed	Neutral
	Unlock side of manual door lock switch pressed	Unlock
Driv Door Sw	Driver side door open	Open
	Driver side door closed	Close
Pass Door Sw	Doors other than driver side door open	Open
	Doors other than driver side door closed	Close
Brake Fluid Level	Brake fluid level at MIN level or higher	Normal
	Brake fluid level lower than MIN level	Low
Parking Brake Sw	Parking brake lever pulled	ON
	Parking brake lever released	OFF
Rear Defogger Sw	Rear end door window defogger switch turned ON with engine running	ON
	Rear end door window defogger switch turned OFF with engine running	OFF
Tail Light Sw	Lighting switch at HEAD or CLEARANCE position	ON
	Lighting switch at OFF position	OFF
Driv Seat belt Sw	Driver side seat belt fastened	Fasten
	Driver side seat belt unfastened	Unfasten
Charge Lamp	Engine at stop with ignition switch turned ON	ON
	Engine running	OFF
Oil pressure switch	Engine at stop with ignition switch turned ON	ON
	Engine running	OFF
A/C Switch	A/C and ignition switch turned ON	ON
	A/C switch turned OFF	OFF

Scan Tool Data Definitions

**Vehicle Speed (km/h, mph):** This parameter indicates the vehicle speed computed by ECM.

**Outside air Temp (°C, °F):** It is detected by outside air temperature sensor.

**Battery Voltage (V):** This parameter indicates battery positive voltage inputted to BCM.

**Coolant Temp (Engine coolant temperature) (°C, °F):** This parameter indicates the engine coolant temperature computed by ECM.

**Engine Speed (RPM):** This parameter indicates the engine speed computed by ECM.

**Fuel Consumption (km/l):** This parameter indicates the fuel consumption computed by ECM.

**Key Reminder Sw (Key reminder switch) (Pulled / Key in):** This parameter indicates the state of the key reminder switch.

**Door key Sw (Door key cylinder switch) (Lock / Neutral / Unlock):** This parameter indicates the state of the door key cylinder switch.

**Door lock Sw (Manual door lock switch) (Lock / Neutral / Unlock):** This parameter indicates the state of the manual door lock switch.

**Driv Door Sw (Driver side door switch) (Open / Close):** This parameter indicates the state of the driver side door switch.

DTC U1144 (No. 1144): Lost Communication with Keyless Start Control Module

S5JB0AA204018

Wiring Diagram

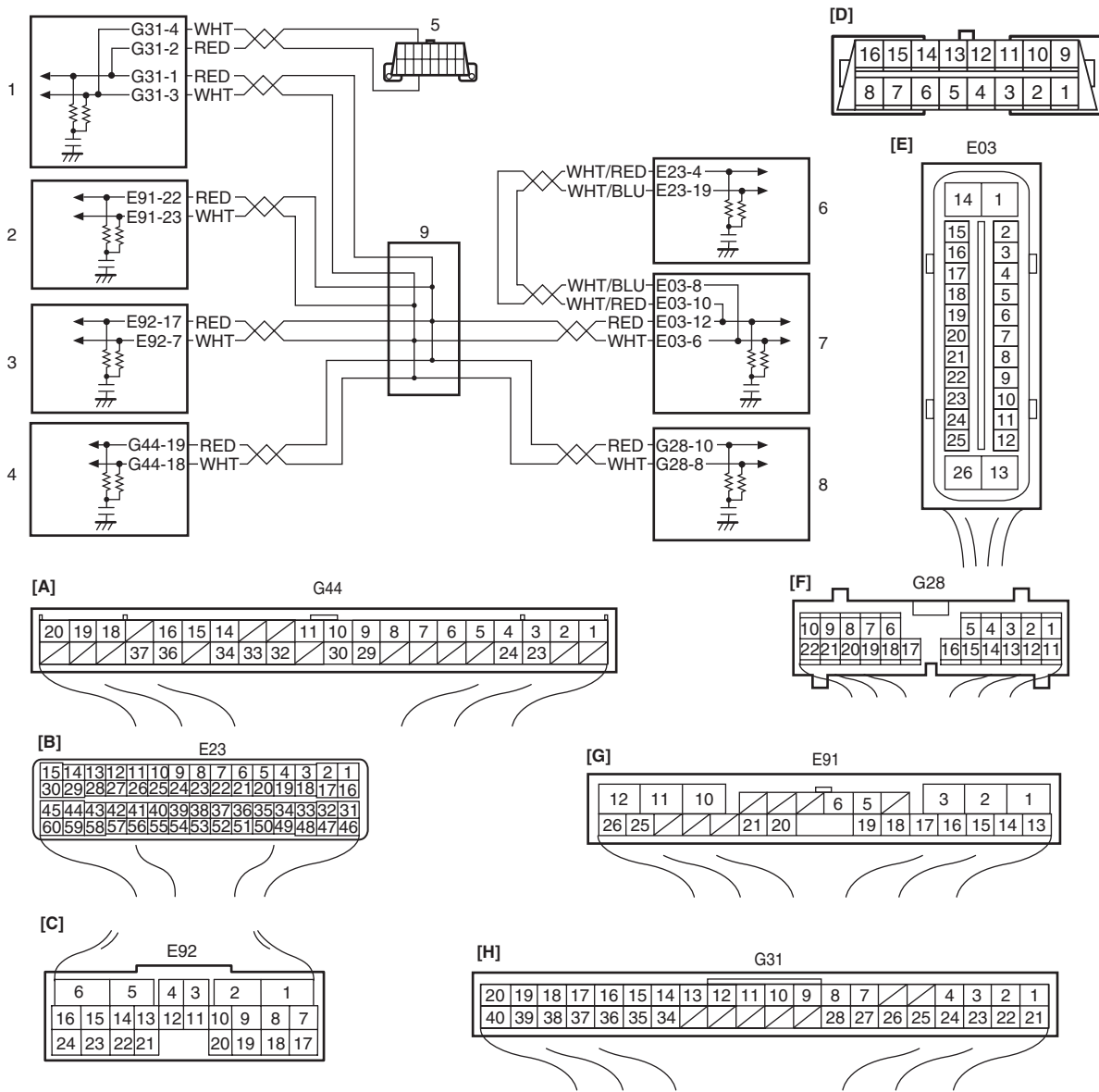

[A]: Keyless start control module connector (viewed from harness side)	1. Keyless start control module
[B]: ECM connector (viewed from harness side)	2. TCM (A/T model)
[C]: TCM connector (viewed from harness side)	3. 4WD control module (if equipped)
[D]: DLC (viewed from harness side)	4. BCM
[E]: ABS hydraulic unit/control module connector (viewed from harness side)	5. DLC
[F]: Combination meter connector (viewed from harness side)	6. ECM
[G]: 4WD control module connector (viewed from harness side)	7. ABS hydraulic unit/control module
[H]: BCM connector (viewed from harness side)	8. Combination meter
	9. Junction connector

I5JB0AA50017-03

## Immobilizer Indicator Lamp Does Not Come ON with Ignition Switch ON and Engine Stop

### Wiring Diagram

Refer to "Immobilizer Control System Wiring Circuit Diagram: ".

### Circuit Description

When the ignition switch is turned ON, ECM transmits the indication ON signal to the combination meter to turn ON the immobilizer indicator lamp in case that there is not any problem with the immobilizer control system. Then, the combination meter turns ON the lamp. When the engine is started up, ECM transmits the indication OFF signal to the combination meter to turn OFF the lamp. Then, the combination meter turns OFF the immobilizer indicator lamp. However, in case that there is some trouble with the immobilizer control system, the immobilizer indicator lamp flashes ON and OFF when the ignition switch is turned ON.

### Troubleshooting

Step	Action	Yes	No
1	<b>Immobilizer indicator lamp power supply check</b> 1) Turn the ignition switch to ON position.  <i>Do other warning lights come ON?</i>	Go to Step 2.	Go to Step 3.
2	<b>Diagnostic Trouble Code (DTC) check</b> 1) Check if DTC P1674, P1675, P1678 and/or P1685 are detected by ECM referring to "Diagnostic Trouble Code (DTC) Check: ".  <i>Is any of them detected?</i>	Perform the troubleshooting referring to the corresponding flowchart in Section 1A.	Replace combination meter with a known-good one and recheck. If the immobilizer indicator lamp still remains OFF, replace ECM with a known-good one and recheck.
3	<b>Fuse check</b> 1) Turn the ignition switch to OFF position. 2) Check if any related fuse is blown.  <i>Is any fuse blown?</i>	Replace blown fuse, and then check for short.	Go to Step 4.
4	<b>Combination meter power supply wire circuit check</b> 1) Remove combination meter referring to "Combination Meter Removal and Installation: in Section 9C". 2) Check for proper connection at "G28-13" and "G28-15" wire terminals of combination meter connector. 3) If OK, turn the ignition switch to ON position and measure voltage between "G28-13" wire terminal of combination meter and vehicle body ground.  <i>Is it 10 – 14 V?</i>	Go to Step 5.	Repair open in power supply wire circuit.
5	<b>Combination meter ground wire circuit check</b> 1) Turn ignition switch OFF position. 2) Measure resistance between "G28-15" terminal of combination meter connector and vehicle body ground.  <i>Is resistance 1 <math>\Omega</math> or less?</i>	Replace combination meter with a know-good one and recheck. If the immobilizer indicator lamp still remains OFF, replace ECM with a known-good one and recheck.	Repair open or high resistance in ground wire circuit.

CLICK HERE TO **DOWNLOAD** THE COMPLETE MANUAL

- Thank you very much for reading the preview of the manual.
- You can download the complete manual from: [www.heydownloads.com](http://www.heydownloads.com) by clicking the link below



- Please note: If there is no response to CLICKING the link, please download this PDF first and then click on it.

CLICK HERE TO **DOWNLOAD** THE COMPLETE MANUAL