

SERVICE MANUAL

E385C

Hino Diesel Engine J08E-TM

Supplement to Service Manual 47374920A

Print no. 47391168A
1st Edition
English 06/12



CLICK HERE TO **DOWNLOAD** THE COMPLETE MANUAL

- Thank you very much for reading the preview of the manual.
- You can download the complete manual from: www.heydownloads.com by clicking the link below



- Please note: If there is no response to CLICKING the link, please download this PDF first and then click on it.

CLICK HERE TO **DOWNLOAD** THE COMPLETE MANUAL

8. Unit

- (1) SI unit is used in this manual. SI unit is the international unit to unify the conventional different international units into one unit per quantity and to promote smooth technical communications.
- (2) This manual shows both the SI unit and conventional units. The conventional units are shown in { }.

	SI unit	Conventional unit	Conversion value ^{*1} (1[Conventional unit] = X [SI unit])		SI unit	Conventional unit	Conversion value ^{*1} (1[Conventional unit] = X [SI unit])
Force	N	kgf	1kgf=9.80665N	Spring constant	N/mm	kgf/mm	1kgf/mm=980665N/mm
Torque ^{*2}	N·m	kgf·cm	1kgf·cm=0.0980665 N·m	Volume	L	cc	1cc=1mL
Pressure	Pa	kgf/cm ²	1kgf/cm ² =98.0665kPa =0.0980665MPa	Efficiency	W	PS	1PS=0.735499kW
		mmHg	1mmHg=0.133322kPa	Calorific value	W·h	cal	1kcal=1.13279W·h
Rotational speed	r/min	rpm	1rpm=1r/min	Fuel consumption rate	g/W·h	g/PS·h	1g/PS·h=1.3596g/kW·h
	min ⁻¹		1rpm=1min ⁻¹				

^{*1} : X means the value when 1 [Conventional unit] is converted to the SI unit.

It is used as the conversion factor from the conventional unit to the SI unit.

^{*2} : The conversion value of the torque may vary depending on the unit.

Observe the standard values described for each unit.

Precautions for work

JP30002010101001

1. General precautions

To ensure safety in work and to prevent accidents, observe the following items :

- (1) Appearance
 - a. Wear safety goggles.
 - b. Do not wear watch, necktie, ring, bracelet, necklace, etc. to prevent accident before work.
 - c. Bind long hair at the back.
 - d. Be sure to wear a cap and safety shoes.
- (2) Safety work
 - a. Do not touch radiator, muffler, exhaust pipe, tail pipe, etc. after stop of the engine to prevent burn.
 - b. Do not put your clothes or tools near the rotating part (in particular, cooling fan or V-belt) during operation of the engine.
 - c. Remove the starter key when the engine is not started.
 - d. Start the engine at a well ventilated place so that carbon monoxide may not be filled.
 - e. Since gas from the fuel or the battery is flammable, do not spark a fire or smoke a cigarette near the area.
 - f. Since the battery fluid is poisonous and corrosive, be careful for handling.
 - g. Do not short-circuit the cable of the battery or starter. Otherwise, the cable may be burned or burn may occur.
 - h. If a tool or rag is left in the engine compartment, it may be bounced with a rotating part of the engine, resulting in injury.

Handling of liquid gasket

JP30002010102008

1. Application of liquid gasket and part assembly procedure

- (1) Remove old liquid gasket on each part and mating part completely. Clean the parts with a rag to prevent deposit of oil, moisture, dirt, etc.
Be sure to overlap parts at the beginning and at the end of application.
- (2) Be careful for offset with the mating part when a part applied with liquid gasket is assembled. Apply the liquid gasket again if offset occurs.
- (3) Assemble parts within 20 minutes after application of the liquid gasket.
If 20 minutes has passed, remove the liquid gasket and apply it again.
- (4) Start the engine at least 15 minutes or more after assembly of parts.

2. Removal of parts

- (1) When parts are removed, do not pry one place only. Remove parts by prying each other using collar and clearance on the flange. When gasket is removed, be careful to prevent entry of gasket offal into the engine.

3. Others

- (1) When the liquid gasket is contained in a tube, use the accompanying winding tool. When it is contained in a cartridge, use the application gun.

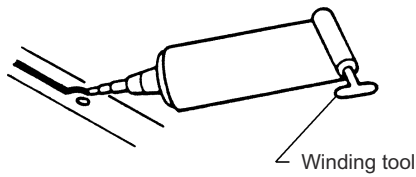

Tube: 150 g

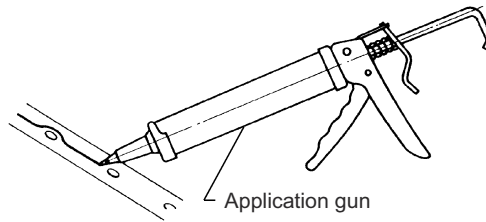

Cartridge type: 300 g

For a tube, desired application width may be obtained from the cut position at the nozzle end.

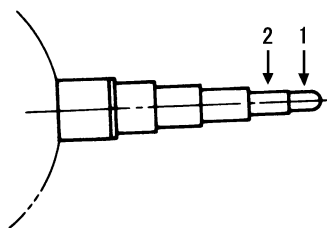

Nozzle of tube

1 : Approx. 2 mm at the 1st section cut

2 : Approx. 5 mm at the 2nd section cut

2 STANDARD VALUE

Engine Body	W5-2-2
Standard value.....	W5-2-2
Tightening torque.....	W5-2-2
Fuel System	W5-2-2
Tightening torque.....	W5-2-2
Emission Control	W5-2-3
Tightening torque.....	W5-2-3
Intake	W5-2-3
Tightening torque.....	W5-2-3
Engine Mechanical	W5-2-3
Standard value.....	W5-2-3
Tightening torque.....	W5-2-11
Exhaust	W5-2-12
Tightening torque.....	W5-2-12
Cooling	W5-2-12
Standard value.....	W5-2-12
Lubrication	W5-2-12
Standard value.....	W5-2-12
Tightening torque.....	W5-2-13
Starting and Charging	W5-2-14
Standard value (alternator 60A).....	W5-2-14
Tightening torque (alternator 60A).....	W5-2-14
Standard value (starter)	W5-2-15
Tightening torque (starter)	W5-2-16
Turbocharger	W5-2-16
Standard value.....	W5-2-16
Tightening torque.....	W5-2-16

Tightening torque

JP30002020205007

Unit : N·m{kgf·cm, lbf·ft}

Tightening area	Tightening torque	Remark
Crankshaft pulley mounting bolt	118{1,203, 87}	
Head cover mounting bolt	28.5{290, 21}	
Camshaft bearing cap mounting bolt	31{320,23}	
Union bolt of leakage pipe	13.5{135, 10}	
Injector harness mounting nut	28{290, 21}	
Camshaft gear mounting bolt	59{600, 44}+90°	
Camshaft housing mounting bolt	23{230, 17}	
Cylinder plug mounting torx bolt	6{60, 4}	
Rocker arm adjusting screw lock nut	25{250, 18}	
Rocker arm support bolt	59{600, 44}	
Head bolt	59{600, 44}+90°+90°	
Cam idle gear shaft mounting bolt	108{1,100, 80}	
Main bearing cap mounting bolt	69{700, 51}+90°+45°	Refer to the main text.
Connecting rod cap mounting nut	69{700, 51}+90°+45°	
Oil check valve	22{220, 16}	
Sub-idle gear shaft mounting bolt	108{1,100, 80}	
Main idle gear shaft mounting bolt	172{1,750, 127}	
Flywheel mounting bolt	186{1,900, 137}	
Flywheel housing mounting bolt	196{2,000, 145}	M16
	55{560, 41}	M10
	36{370, 27}	M8
Flywheel housing stay - Cylinder block	97{990, 72}	M12
Flywheel housing stay - Flywheel housing	171.5{1, 750, 126}	M14
Rear end plate torx bolt	55{560, 41}	
Supply pump bearing case mounting bolt	28.5{290, 21}	
Pump drive idle gear shaft mounting bolt	108{1,100, 80}	

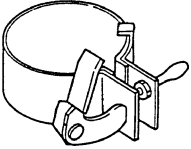
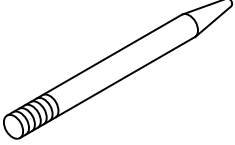
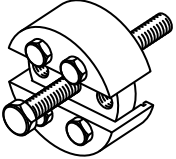
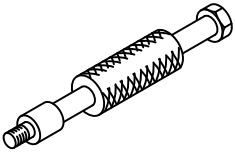
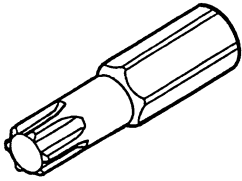
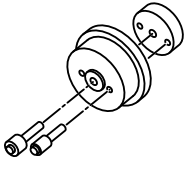
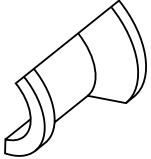
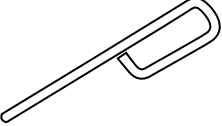
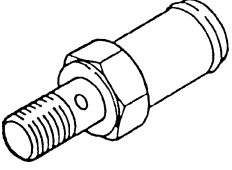
Shape	Part No.	Name	Remark
	Suitable Tool	Piston ring holder	For piston mounting
	Suitable Tool	Guide	For assembly/disassembly of flywheel
	0380100034	Oil seal puller	For crankshaft rear oil seal removal
	380100035	Sliding hammer	For main/sub idle gear assembly and cam idle gear shaft removal
	380100036		
	380100037	Socket wrench	For assembly/disassembly of Torx bolt
	380100038	Oil seal press	For crankshaft rear oil seal press-fit
	Suitable Tool	Guide	For insertion of cylinder liner
	0380100039	Tool	For cooling jet repair
	380100040	Check bolt	For cooling jet inspection and adjustment

Installation

JP30002040702003

1. Connection of fuel hose

- (1) Insert a fuel hose and fix it with a hose band.

Work after installation

JP30002040702004

1. Inspection of engine oil

- (1) Make sure that the exhaust valve is closed.
- (2) Pour engine oil.

Engine oil amount (L{us gal})

Oil pan	Oil filter
Approx. 26{6.87}	Approx. 1.7{0.45}

**Hino genuine Blue Ribbon ePRO-extra
SAE # 10W-30**

**Hino genuine Blue Ribbon ePRO-super
SAE # 30**

- ⚠ CAUTION**
- Check the amount of oil with an oil level gauge.
 - Vehicles with the DPR (Diesel Particulate Reduction cleaner) must use the specified (recommended) brand engine oil to maintain the function of the DPR for a long time.

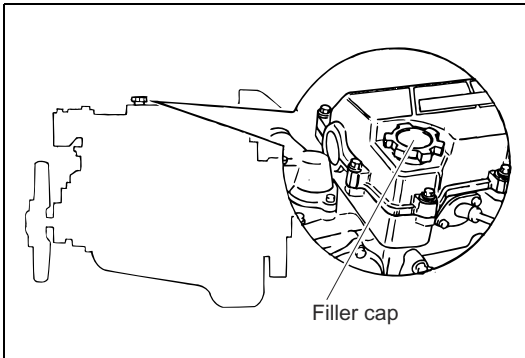

SAPH300020400009

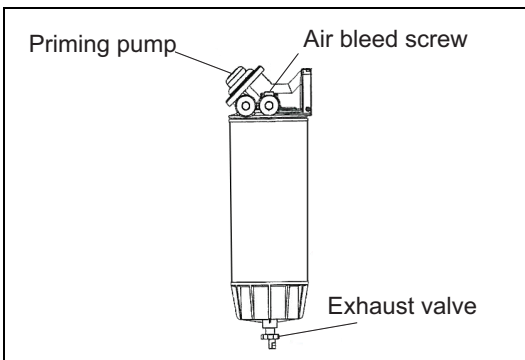

SMC0162

2. Air bleeding of fuel system

- (1) Place a container to receive drained fuel under the fuel filter.
- (2) Loosen the air bleeder plug and send fuel pumping the priming pump.
Put the rag to the air bleeder plug to absorb drained fuel.
- (3) Pump the priming pump until the fuel without bubbles comes out from the air bleeder plug.
- (4) Tighten the air bleeder plug.
Tightening torque: 1.8 - 2.2 N·m
{18.3 - 22.4 kgf·cm, 1.3 - 1.6 lbf·ft}
- (5) Pump the priming pump again more than 20 times.

- ⚠ CAUTION**
- After work, wipe off spilled fuel. After start of the engine, make sure that there is no fuel leak.

Inspection of supply pump

JP30002050704004

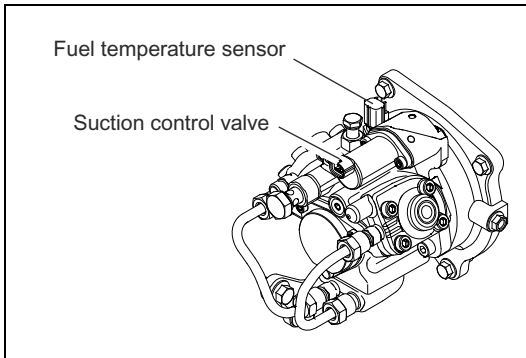

SAPH300020500016

1. Inspection of suction control valve and fuel temperature sensor

- (1) Measure the resistance of the suction control valve terminals and the fuel temperature sensor terminals using a circuit tester. If it is beyond the standard, remove the supply pump assembly and request for replacement at the Denso service shop.

	Between suction control valve terminals
Standard value	7.65 - 8.15Ω (at 20°C {68°F})

	Terminals between fuel temperature sensors
Standard value	13.5 - 16.5kΩ (at -20°C{-4°F})
	2.2 - 2.7kΩ (at 20°C{68°F})
	0.29 - 0.35kΩ (at 80°C{176°F})

Replacement of injector

JP30002050704005

1. Removal of injector

- (1) Remove the fixing bolt and remove the plate and the injection pipe oil seal.
- (2) Remove the nozzle clamp holder and remove the injector.

2. Installation of injector

- (1) Attach a new O-ring to the groove of the cylinder head and insert the injector.

CAUTION • Apply engine oil to the O-ring and be careful to prevent pinching of the O-ring.

- (2) Install the nozzle clamp holder and tack weld the injector temporarily.

CAUTION • Do not fix the nozzle holder until the injection pipe is tack welded.

- (3) Put a new injection pipe oil seal on the injector and install the plate.

CAUTION • Install the injection pipe oil seal to prevent undue force to the injection nozzle. (Offset position between the injection pipe oil seal and the injection nozzle may cause oil leak or poor assembly of the injection pipe.)

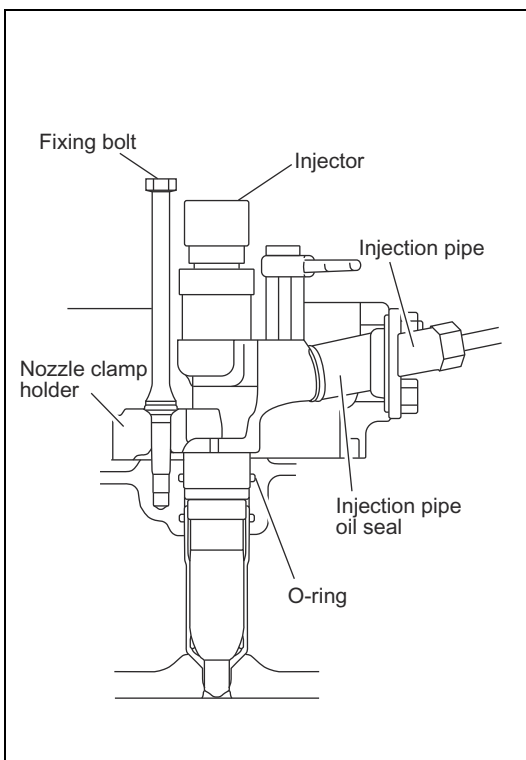

SAPH300020500017

7 ELECTRICAL

Electrical System.....	W5-7-2
Part layout.....	W5-7-2
Layout of components.....	W5-7-4
Inspection of components.....	W5-7-6
Installation of component.....	W5-7-8
Installation of starter	W5-7-8
Removal of alternator.....	W5-7-9
Installation of alternator	W5-7-10

8 INTAKE

Intake Manifold	W5-8-2
Part layout.....	W5-8-2
Replacement.....	W5-8-3

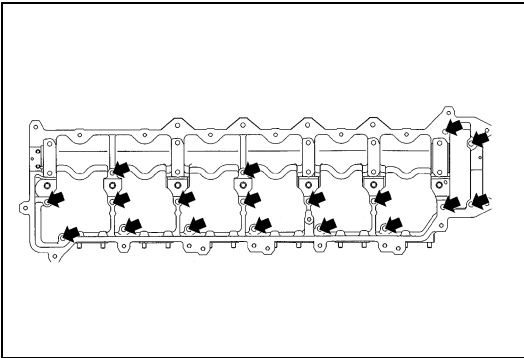

SAPH300020900012

2. Installation of camshaft housing

- (1) Install new gasket and camshaft housing.

Tightening torque : 23 N·m {230 kgf·cm, 17 lbf·ft}

! CAUTION • Refer to the figure for the mounting bolt position.

Liquid gasket application procedure for cylinder plug (only when cylinder plug is removed)

JP30002090704003

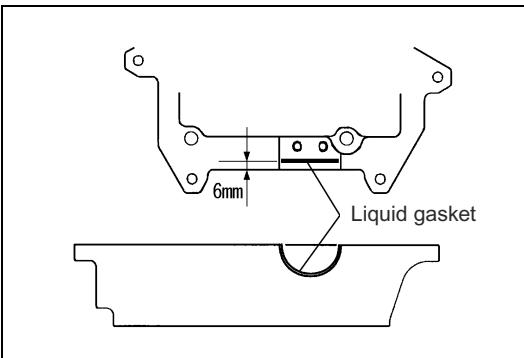

SAPH300020900013

1. Remove liquid gasket from the cylinder plug and the camshaft housing.
2. Apply the liquid gasket [Threebond TB1207B (black) or equivalent] to the semi-circular areas at the front/rear ends of the camshaft housing and install the cylinder plug.

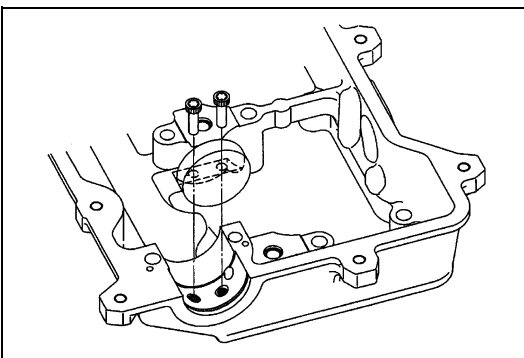

SAPH300020900014

3. Tighten the Torx bolt.

Tightening torque : 6 N·m {60 kgf·cm, 4 lbf·ft}

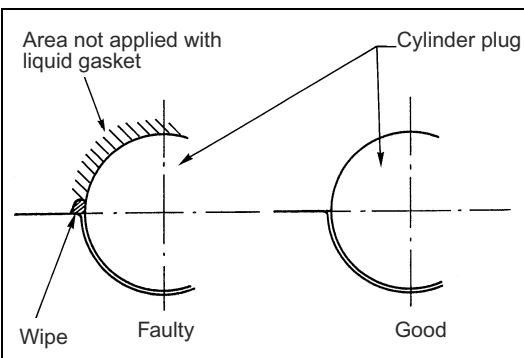

SAPH300020900015

! CAUTION • Be sure to wipe protruding liquid gasket.
• Make sure that the cylinder plug is seated without inclination to the front or back.

Timing Gear Cover and Flywheel Housing

Part layout

JP30002090402003

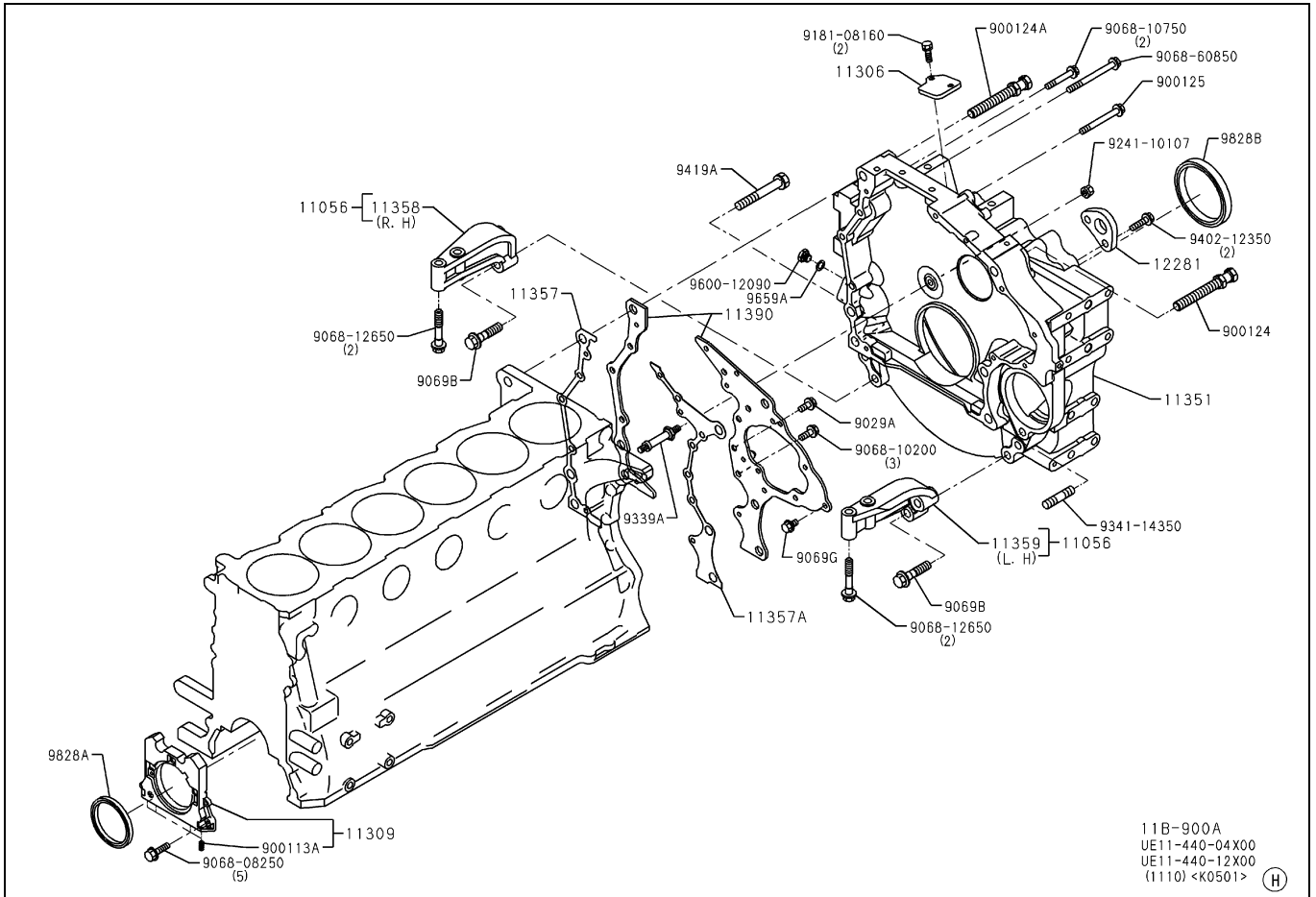

11056	Flywheel housing stay	11357A	Gasket*
11309	Oil seal retainer	11390	End plate
11351	Flywheel housing	9828A	Front oil seal*
11357	Gasket*	9828B	Rear oil seal*

*Parts not to be reused.

Tightening torque

9029A	55N·m{560kgf·cm, 41lbf·ft}	90124	196N·m{2,000kgf·cm, 145lbf·ft}
9068-10200	55N·m{560kgf·cm, 41lbf·ft}	90124A	196N·m{2,000kgf·cm, 145lbf·ft}
9068-10750	55N·m{560kgf·cm, 41lbf·ft}	90125	36N·m{370kgf·cm, 27lbf·ft}
9068-12650	97N·m{990kgf·cm, 72lbf·ft}	9241-10107	55N·m{560kgf·cm, 41lbf·ft}
9068-60850	55N·m{560kgf·cm, 41lbf·ft}	9339A	55N·m{560kgf·cm, 41lbf·ft}
9069B	171.5N·m{1,750kgf·cm, 126lbf·ft}	9419A	196N·m{2,000kgf·cm, 145lbf·ft}

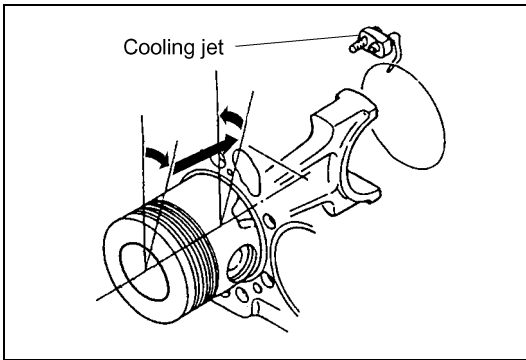

SAPH300020900073

- (4) Insert the piston carefully so that the connecting rod may not come in contact with the cooling jet.

- ! CAUTION**
- Face the "0" mark on the piston toward the exhaust side for insertion.
 - Set the crankshaft of the cylinder as the top dead center for assembly.
 - Do not damage the cylinder liner, crankshaft and cooling jet during work.

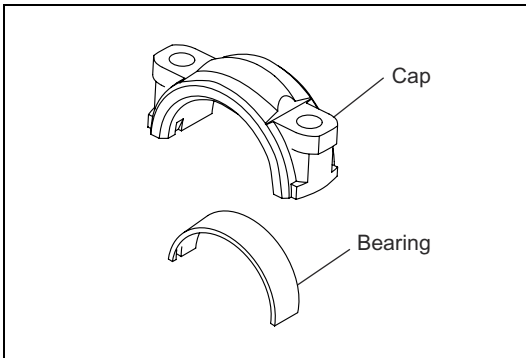

SAPH300020900074

- (5) Install the connecting rod bearing to suit concave shape of the connecting rod cap.

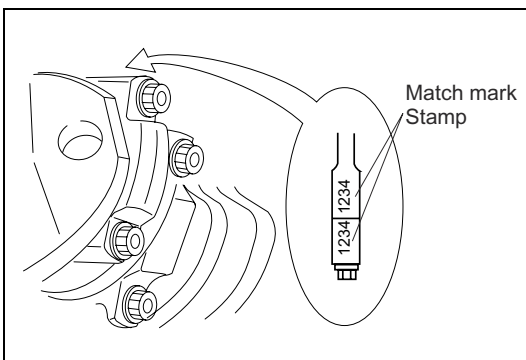

SAPH300020900075

- (6) Align the match mark of the connecting rod cap with that of the connecting rod and fix it with a dowel pin.

- ! CAUTION**
- Do not change the combination between the connecting rod and the connecting rod cap.

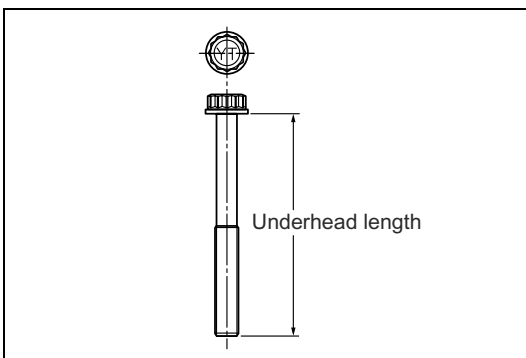

SAPH300020900076

- (7) Measure the underhead length of the connecting rod bolt using a vernier calipers. If it is out of the service limit, replace it with a new one.

Service limit (mm{in.})	68.0{2.6772} or less
--------------------------------	-----------------------------

- (8) Apply engine oil to the connecting rod bolt thread and the seat and install it on the connecting rod.

Replacement of crankshaft pulley

JP30002090704009

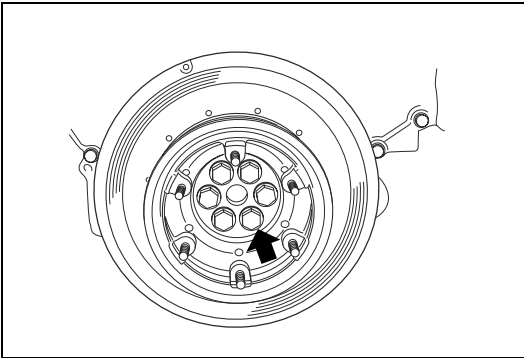

SAPH300020900108

1. Removal of crankshaft pulley

- (1) Remove bolts and remove the crankshaft pulley.

NOTICE

- Insert a large flat tip screwdriver into the flywheel gear from the flywheel housing inspection hole to prevent turning of the crankshaft.

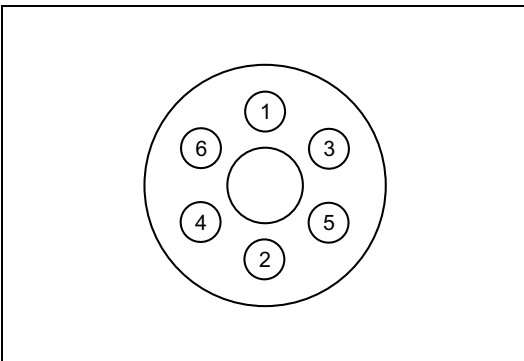

SAPH300020900109

2. Installation of crankshaft pulley

- (1) Apply engine oil to the bolt seat and the bolt thread of the crankshaft pulley mounting bolt.
- (2) Install the crankshaft pulley on the crankshaft and tighten it according to the figure.

Tightening torque : 118 N·m {1,200 kgf·cm, 87 lbf·ft}

NOTICE

- Insert a large flat tip screwdriver into the flywheel gear from the flywheel housing inspection hole to prevent turning of the crankshaft.

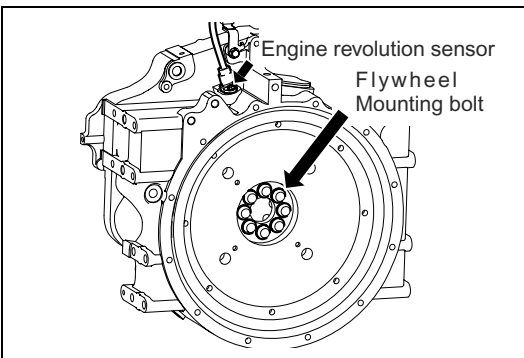

SAPH300020900110

Replacement of flywheel

JP30002090704010

1. Removal of flywheel

- (1) Remove the engine revolution sensor.
- (2) Remove bolts fixing the flywheel.

NOTICE

- Insert a large flat tip screwdriver into the flywheel gear from the flywheel housing inspection hole to prevent turning of the crankshaft.

- (3) Install a tool into the bolt hole of the crankshaft to remove the flywheel.

Guide

! CAUTION

- Since the flywheel is heavy, be careful for handling.
- Do not give impact to the special tool during work.

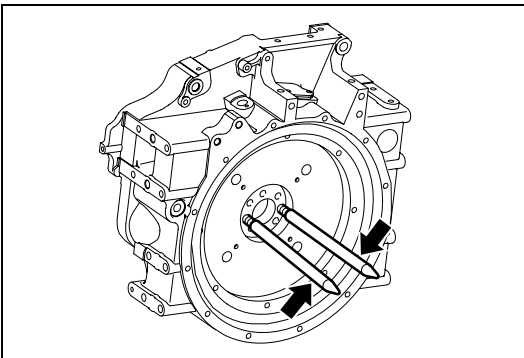

SAPH300020900111

CLICK HERE TO **DOWNLOAD** THE COMPLETE MANUAL

- Thank you very much for reading the preview of the manual.
- You can download the complete manual from: www.heydownloads.com by clicking the link below



- Please note: If there is no response to CLICKING the link, please download this PDF first and then click on it.

CLICK HERE TO **DOWNLOAD** THE COMPLETE MANUAL

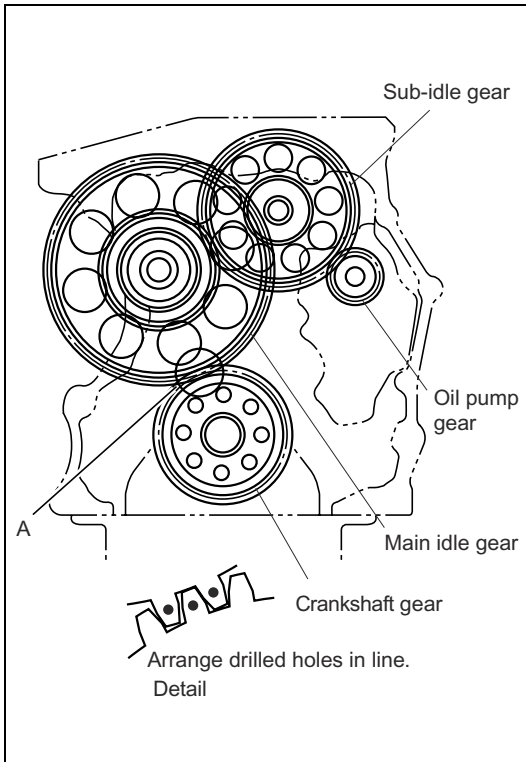

- (3) Face the lubricating hole of the idle gear shaft toward the oil pan (downward). Install A in the figure by adjusting the timing of the crankshaft gear and the main idle gear as in the detailed drawing.

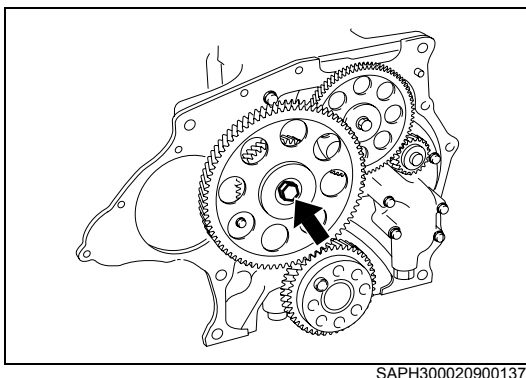

- (4) Apply engine oil to the bolt seat and the bolt thread of the idle gear shaft mounting bolt.
- (5) Install the idle gear shaft mounting bolt.
Tightening torque : 172 N·m {1,750 kgf·cm, 127 lbf·ft}
- (6) Measure backlash and end play of each idle gear. Make sure that it is within the standard value.

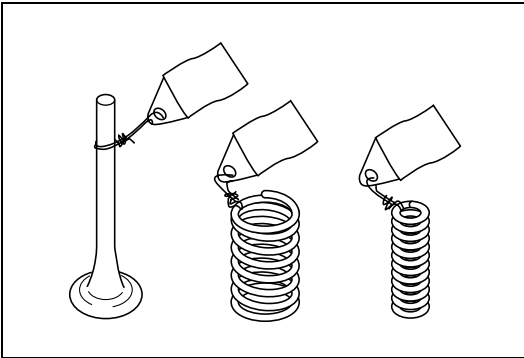

SAPH300020900167

(2) Remove the intake and exhaust valves.

- ! CAUTION** • Attach a tag with the applicable cylinder number to the valve so that combinations of the valve and the cylinder head may not be mixed.

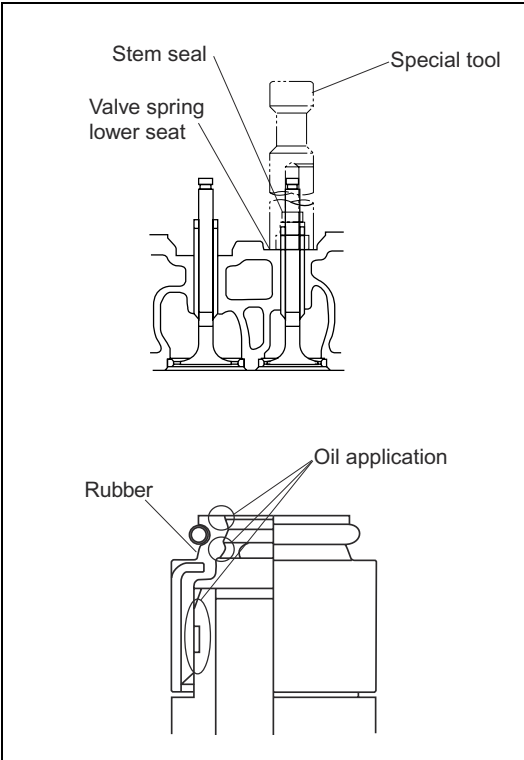

SAPH300020900168

5. Replacement of valve stem seal

(1) After removing the valve stem seal, assemble the valve spring lower seat. Apply engine oil to the lip and the inner surface of the stem seal. Strike the valve guide using a special tool until the special tool comes in contact with the valve spring lower seat

Special tool : 308100033 Bar

- ! CAUTION** • After assembly of the stem seal, make sure that there is no deformation, crack or inclination of the rubber.

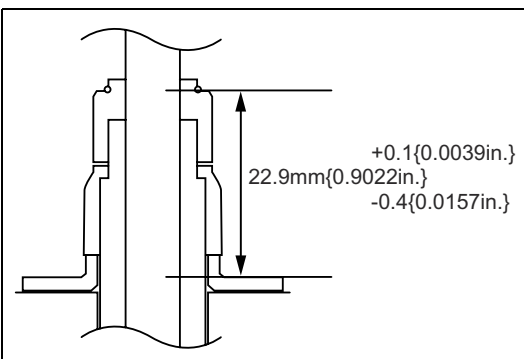

SAPH300020900169

(2) After striking, check the height.

Standard value (mm{in.})	22.5 - 23.0 {0.8858 - 0.9055}
---------------------------------	--

11 COOLING

Cooling System	W5-11-2
Cooling system drawing	W5-11-2
Part layout	W5-11-3
Replacement of thermostat case	W5-11-4
Inspection of thermostat	W5-11-5
Replacement of coolant pump	W5-11-6

Replacement of oil cooler

JP30002120704001

1. Removal of oil cooler

- (1) Remove bolts and remove the oil cooler.

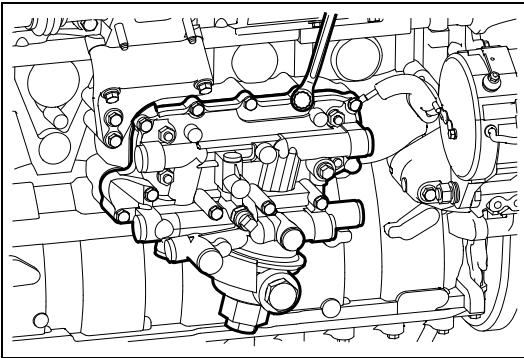

SAPH300021200004

- (2) If it is difficult to remove the oil cooler due to liquid gasket sticking to the cylinder block, put a flat tip screwdriver at the protrusion in the figure for removal.

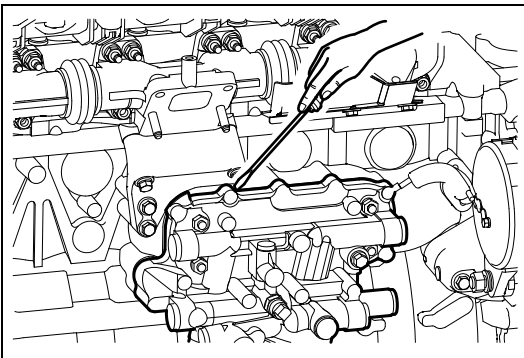

SAPH300021200005

2. Installation of oil cooler

- (1) Assemble the new D-ring into the D-ring groove of the oil cooler.

! CAUTION • Face the D-ring flat area toward the oil cooler.

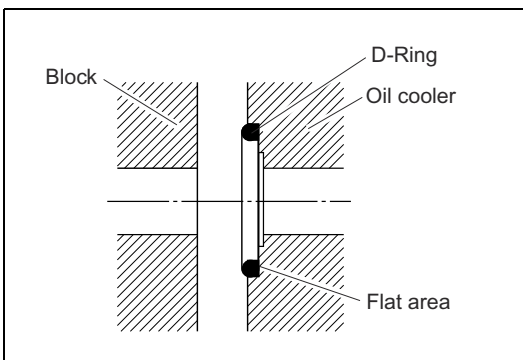

SAPH300021200006

- (2) Remove contamination on the joint surface between the oil cooler and the cylinder block using a scraper. Apply the liquid gasket [Threebond TB1207 (silver) or equivalent] to the oil cooler as shown in the figure.

! CAUTION • Apply it continuously.
 • Apply the liquid gasket at the width of 1.5 to 2.5 mm{0.0590 to 0.0984 in.}.
 • Install the oil cooler within 20 minutes after application of the liquid gasket.

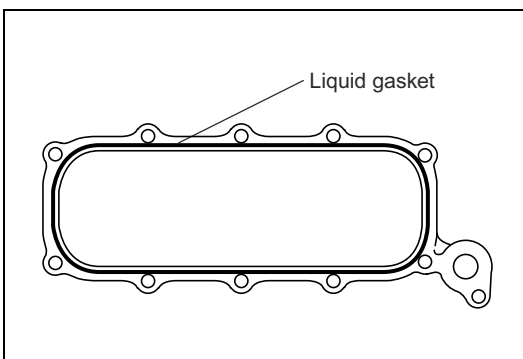

SAPH300021200007

Inspection of lubrication status

JP30002120703001

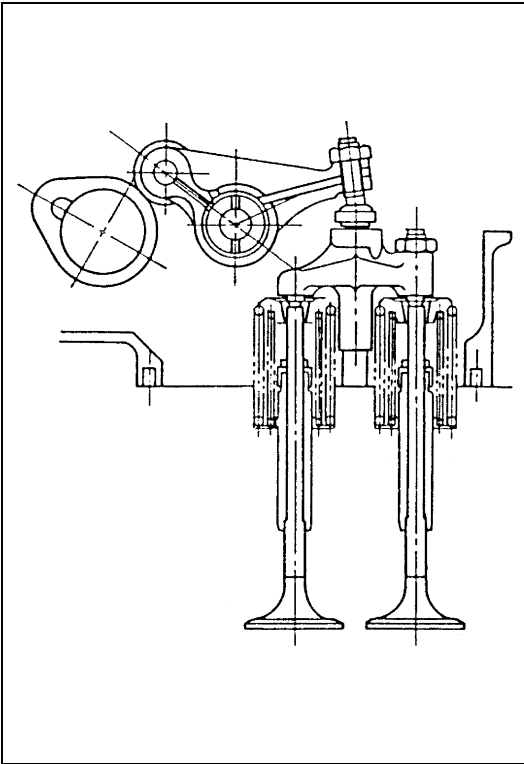

SAPH300021200030

1. Inspection of valve system

! CAUTION • Perform inspection with the water temperature at 60 °C{140°F}.

(1) Remove the head cover.

! CAUTION • To prevent spread of engine oil, attach a jig which cuts a head cover in half. Cut it to the degree that the camshaft is covered.

(2) Adjust the engine revolution to the standard idling revolution [550r/min{rpm}].

(3) After start of the engine, make sure that oil is supplied to the areas below of all rocker arms within about 10 seconds.

- Roller and cam surface
- Cross head and spring upper seat surface through adjusting screw

! CAUTION • If time until lubrication is long or if lubrication is not performed, the oil pressure may be low or the oil channel may be clogged. Seizure, abnormal wear or abnormal noise may occur due to insufficient lubrication.

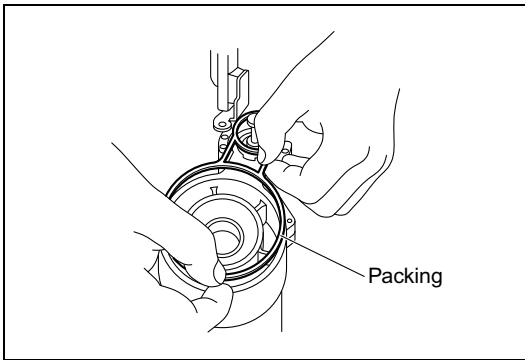

SAPH300021300024

18. Removal of packing

- (1) Turn the center bracket upside down again and remove the packing.

⚠ CAUTION • Packing must not be reused.

Inspection of components

JP30002130703001

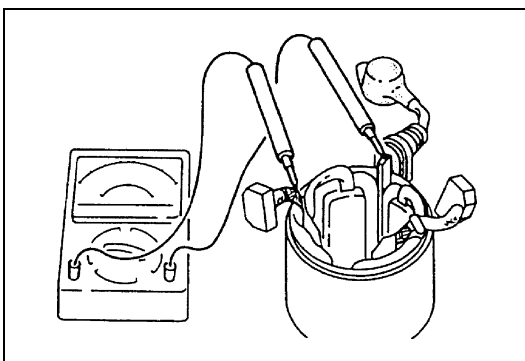

SAPH300021300025

1. Inspection of yoke assembly

- (1) Make sure that the coil lead wire has electric continuity using a circuit tester.
- (2) Make sure that there is no discoloration at the coil.

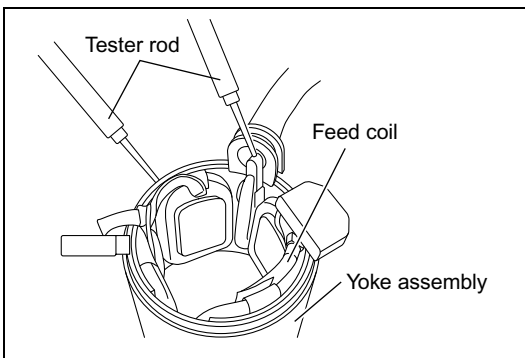

SAPH300021300026

- (3) Measure the resistance between the coil lead wire and the yoke with a circuit tester and check insulation. When the value is below the service limit, replace it.

Service limit	1kΩ or less
----------------------	--------------------

⚠ CAUTION • After cleaning and drying, take measurements.

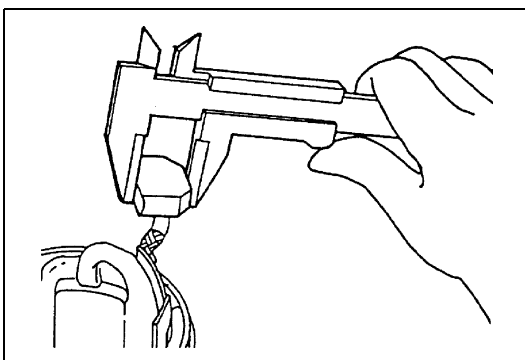

SAPH300021300027

- (4) Measure the brush length using vernier calipers.

Standard value (mm{in.})	Service limit (mm{in.})
18{0.7087}	13{0.5118} or less

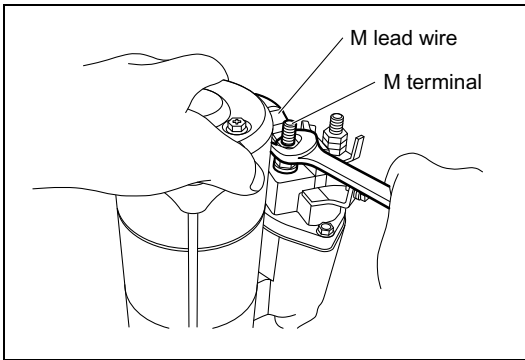

SAPH300021300002

18. Installation of lead wire

- (1) Install the M lead wire.

19. Lubrication

Refer to the following figure and table for lubricant to be applied.

⚠ CAUTION • There shall be no lubricant on the commutator surface, brush and contact.

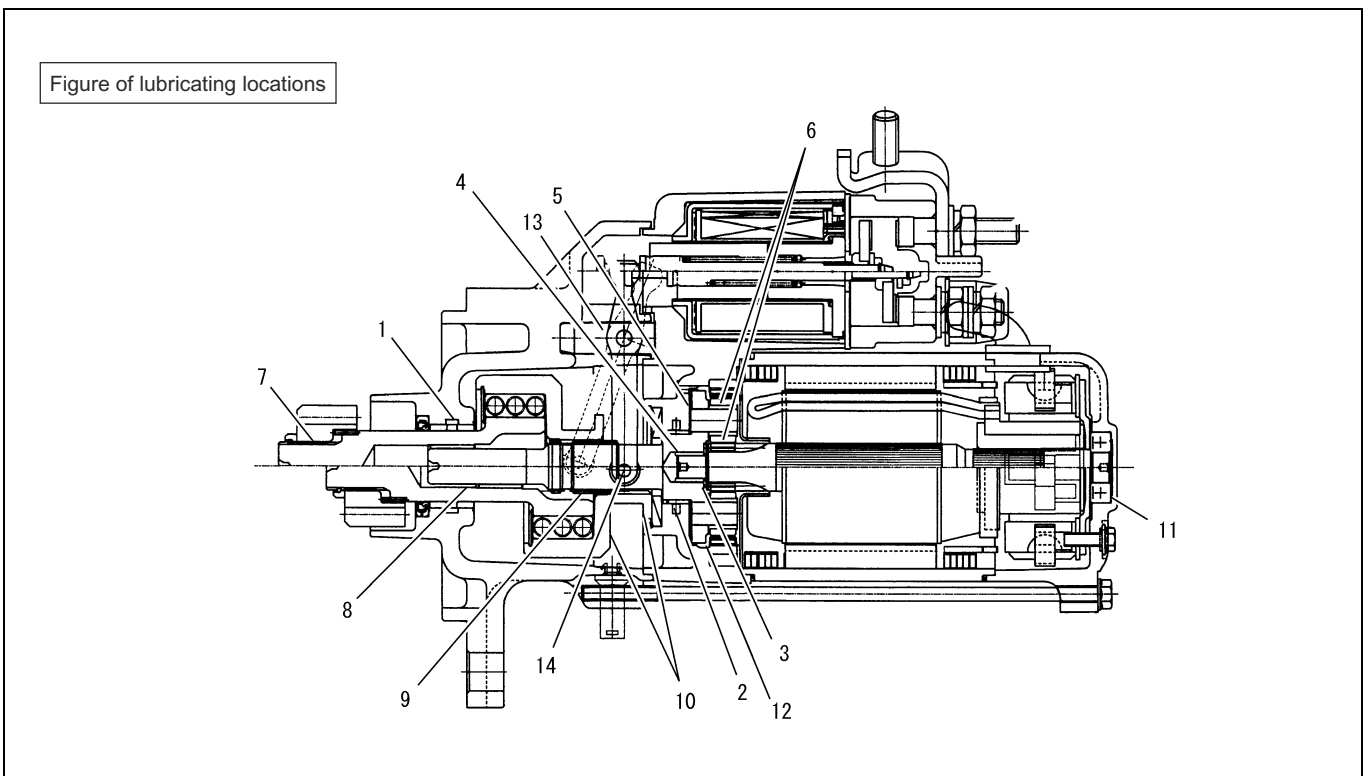

SAPH300021300047

Assembly (60A)

JP30002130702004

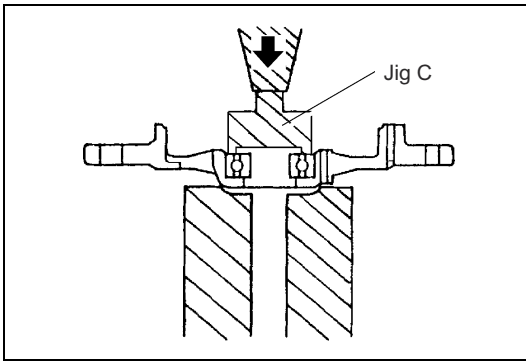

SAPH300021300074

- ⚠ CAUTION**
- Place a rubber mat and perform work on the mat.

1. Assembly of front

- (1) Press fit a new ball bearing into the front bracket using a press and jig C.

- ⚠ CAUTION**
- Place jig C at the outer race of the ball bearing.

- Removed bearing must not be reused.

- (2) Install the bearing cover with bolts.

Tightening torque :

1.9 - 2.5 N·m {20 - 25 kgf·cm, 1 - 2 lbf·ft}

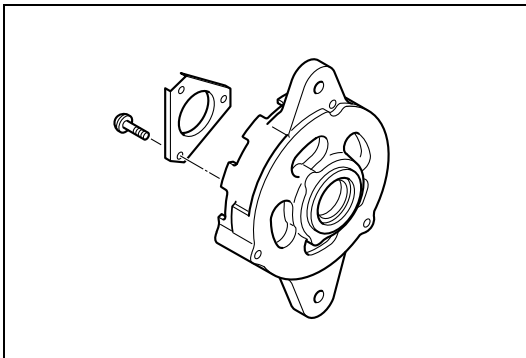

SAPH300021300075

- (3) Install the rotor assembly using a press.

- ⚠ CAUTION**
- Be sure to support the inner race of the bearing for press fit of the rotor.

- Do not damage the shaft.

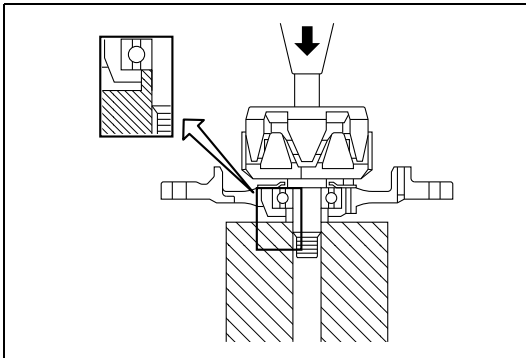

SAPH300021300076

- (4) Install the space collar, fan and pulley on the shaft of the rotor assembly.

Tightening torque :

127 - 157 N·m {1,300 - 1,600 kgf·cm, 94 - 116 lbf·ft}

- ⚠ CAUTION**
- Tie around a general V-belt in the pulley groove and fix the pulley with a vice.

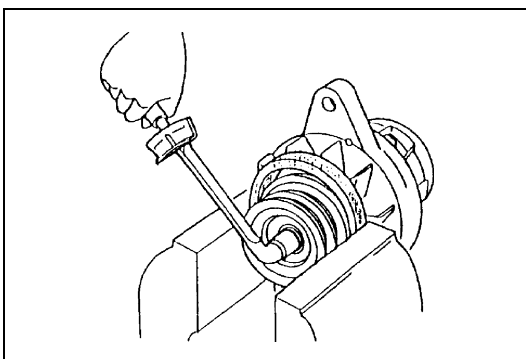

SAPH300021300077

Special Tool Details

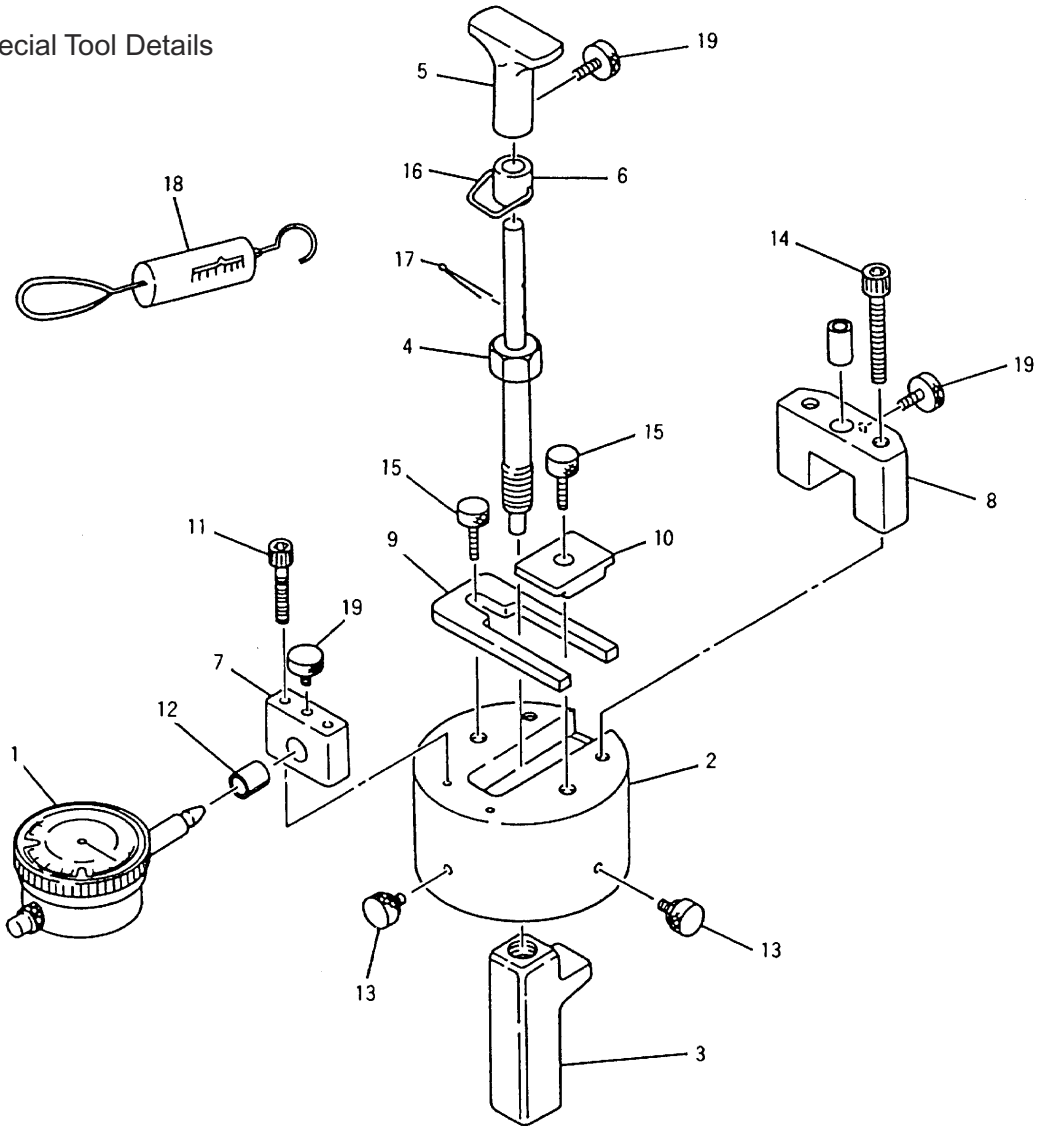

Key No.	Part name	Key No.	Part name
Assembly	Tool assembly	10	Stopper
1	Gauge (dial gauge)	11	Bolt
2	Guide	12	Sleeve
3	Stopper	13	Bolt
4	Bar	14	Bolt
5	Puller	15	Bolt
6	Sleeve	16	Hook
7	Plate	17	Snap ring (cotter pin)
8	Plate	18	Bar (spring)
9	Guide	19	Bolt

SAPH300021400009

Status	Cause	Action
Exhaust smoke is white.	Engine oil runs out to the blower or the turbine due to clogging or deformation of the oil return pipe.	Repair or replace pipe.
	Negative pressure at the back of the blower impeller is increased and engine oil runs out to the blower.	Check and replace the pipe. Replace or clean the air cleaner element.
	Seal ring is excessively worn or damaged due to excessive wear of the bearing.	Disassemble and repair turbocharger.
Oil is quickly reduced.	Seal ring is excessively worn or damaged due to excessive wear of the bearing.	Disassemble and repair turbocharger.
	Engine oil enters into exhaust gas before the turbocharger.	Check and service engine parts.
Low engine output	Gas leak from exhaust system parts	Check and repair faulty areas.
	Air leak from blower outlet	Check and repair faulty areas.
	Clogging of air cleaner element	Clean or replace air cleaner element
	Contamination of or damage to turbocharger	Replace turbocharger.
Acceleration (follow-up of turbocharger) is poor (slow).	Carbon deposit at the turbine (disc sealing area) makes revolution of the turbine heavy.	Replace engine oil and clean turbocharger.
	Air and gas leak from intake/exhaust system parts	Check and repair faulty areas.
	Combustion is faulty.	Check the engine fuel system and recover correct combustion status.
Abnormal noise	If the gas passage is extremely narrowed due to clogging at the turbine case nozzle or if acceleration is performed, reverse flow (usually called surging) occurs due to clogging of blower discharge air.	Replace turbocharger.
	Revolving part is in contact.	Replace turbocharger.
	Air and gas leak from intake/exhaust system parts	Check and repair faulty areas.
Vibration	Loosening between turbocharger and intake/exhaust pipe and between oil pipe and mounting area	Check the turbocharger mounting status and repair faulty areas.
	Failure of metal, contact between revolving part and peripheral parts, or damage to the blower impeller of the turbine rotor due to entry of foreign matter is found.	Replace turbocharger. Remove foreign matter completely, if any.
	Balance of revolving body is poor.	Replace revolving body.

[a] Failure diagnosis and [b] Alarm display (alarm status)	DTC code	Diagnosis monitor code	Estimated failure cause
a. Low output	P0490	81	EGR solenoid 1 malfunction (VB short-circuit)
b. Failure code(DTC code) indication.	P0605	3	Flash ROM error
	P0607	3	Monitoring IC malfunction in CPU
	P0628	75	SCV malfunction (Full discharge mode)
	P1211	57	Injector common 1 short to GND Failure of ground short-circuit and common 1
	P1212	57	Injector common 1 short to BATT Failure of +B short-circuit and common 1
	P1212	57	Injector common 1 short to BATT Failure of open and common 1
	P1214	58	Injector common 2 short to GND Failure of ground short-circuit and common 2
	P1215	58	Injector common 2 short to BATT Failure of +B short-circuit and common 2
	P1215	58	Injector common 2 short to BATT Failure of open and common 2
	P1401	89	EGR valve 2 stick
	P1402	82	EGR solenoid 2 malfunction (Open/ground short-circuit)
	P1403	82	EGR solenoid 2 malfunction (VB short-circuit)
	P1601	2	Injector correction data conformity error
	P2228	15	Atmospheric pressure sensor
	P2229	15	Atmospheric pressure sensor circuit high input
	P2635	75	Supply pump SCV sticking
P2635	77	Supply pump malfunction	

Engine overheat (DTC code P0217/diagnosis monitor code 6)

JP30002160601008

1 Measurement of resistance between terminals

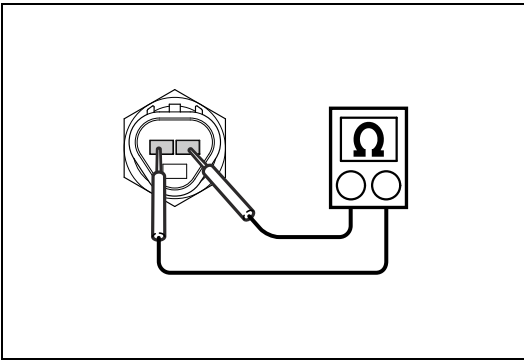

SAPH300021600022

1. Set the starter key to "LOCK", disconnect the connector of the coolant temperature sensor and measure the resistance between No. 1 and No. 2 terminals at the sensor.

Standard value (Measure either one point of the following.)

- : 2.45k Ω (Coolant temperature at 20 °C{68 °F})
- : 1.15k Ω (Coolant temperature at 40 °C{104 °F})
- : 584 Ω (Coolant temperature at 60 °C{140 °F})
- : 318 Ω (Coolant temperature at 80 °C{176 °F})

NOTICE

- This code is displayed when the coolant temperature sensor is normal and the coolant temperature is 115 °C{221 °F} or more.
- While this failure code is detected, the maximum injection volume is restricted. When the coolant temperature is 80 °C{176°F} or less, normal control is resumed.

NG

Failure of coolant temperature sensor

OK

Failure of engine cooling system

Engine overrun (DTC code P0219/diagnosis monitor code 7)

JP30002160601009

1. This failure code is displayed when the engine speed of 4,000 r/min or more is detected. While this failure code is detected, fuel injection is stopped. When the engine speed is lower than 3,800 r/min., fuel injection is resumed.

NOTICE

- The objective of this failure code is not to detect overrun due to failure of this system, but to memorize high revolution of the engine. (Detection of shifting error)
- Engine speed may be incorrectly recognized with noise on the speed sensor signal due to harness failure or modification, resulting in detection of overrun.

3 Measurement of voltage between terminals

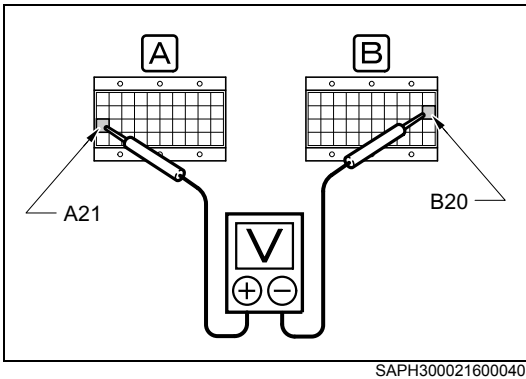

1. Set the starter key to "LOCK" and connect the connector of the accelerator sensor.
2. Set the starter key to "ON" and measure the voltage between terminal A21 and terminal B20 of the signal check harness.

CAUTION • The standard value in full throttle status is based on the actual measurement value.

Standard value

: 0.7 V or less (idle status)

: 3.55 to 4.4 V (full throttle status)

NG

[4] Go to measurement of voltage between terminals.

OK

Engine ECU failure, ECU connector failure

4 Measurement of voltage between sensor terminals

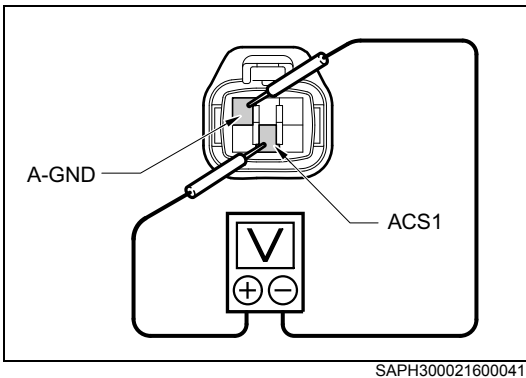

1. Leave the connector of the accelerator sensor connected.
2. Measure the voltage between the ACS1 terminal and the A-GND terminal of the accelerator sensor connector (at vehicle harness side).

CAUTION • The connector in the figure is viewed from the fitting surface.
• The standard value in full throttle status is based on the actual measurement value.

Standard value

: 0.7 V or less (idle status)

: 3.55 to 4.4 V (full throttle status)

NG

Accelerator sensor failure

OK

Disconnection or short-circuit of harness

Injector circuit malfunction (DTC code P0201 to P0206/diagnosis monitor code 51 to 56)

JP30002160601025

DTC	P0201	Injector circuit malfunction -cylinder 1
DTC	P0202	Injector circuit malfunction -cylinder 2
DTC	P0203	Injector circuit malfunction -cylinder 3
DTC	P0204	Injector circuit malfunction -cylinder 4
DTC	P0205	Injector circuit malfunction -cylinder 5
DTC	P0206	Injector circuit malfunction -cylinder 6

1 Measurement of resistance between terminals

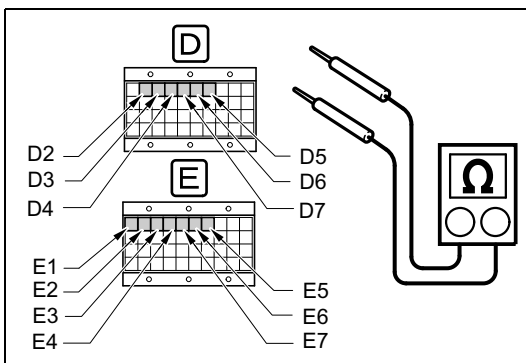

1. Set the starter key to "LOCK" and connect the signal check harness.
2. Disconnect the ECU side connector of the signal check harness and measure the resistance between terminals.

Failure code	Failure area (injector)	Terminal to measure resistance
P0201 (51)	# 1	D2 ↔ D5
P0202 (52)	# 2	D3 ↔ D5
P0203 (53)	# 3	D4 ↔ D6
P0204 (54)	# 4	E1 ↔ E6
P0205 (55)	# 5	E3 ↔ E6
P0206 (56)	# 6	E2 ↔ E7

Standard value : 2 Ω or less

NG

[3] Go to measurement of resistance between injector terminals.

OK

2 Check of diagnosis code

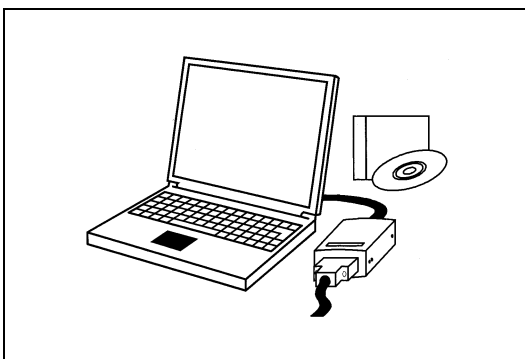

1. Set the starter key to "LOCK" and connect the ECU side connector of the signal check harness.
2. Start the engine and delete the past failures with the failure diagnosis tool (HINO field support system) using PC.
3. If the same failure code is output again, replace the common rail ECU. If the normal code is output, it is considered that a temporary error has occurred.

EGR valve 1 stick (DTC code P0404/diagnosis monitor code 88)

JP30002160601031

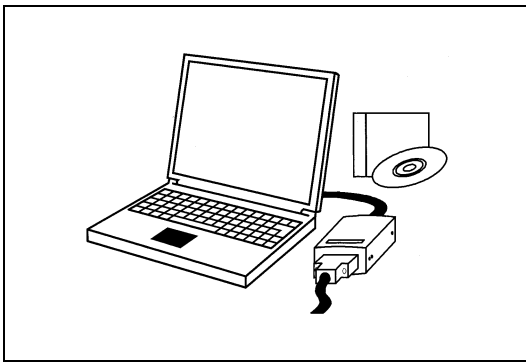
1 Inspection with PC

SAPH300021600004

1. After display of failure code, check EGR with the failure diagnosis tool (HINO field support system) using PC.
2. Connect the failure diagnosis tool (HINO field support system) using PC and set the starter key to "ON".
3. Make sure that there are no EGR solenoid valve 1 failure (DTC code P0489, P0490) and EGR lift sensor 1 failure (DTC code P0405, P0406).
4. Make sure that the actual opening follows the opening indicated on the EGR inspection screen.

Standard value : Within 5 % error

NG

EGR failure

OK

Normal

"Reference : 3-6, Failure diagnosis using DST-1, Engine ECU, Engine diagnosis code"

EGR valve 2 stick (DTC code P1401/diagnosis monitor code 89)

JP30002160601032

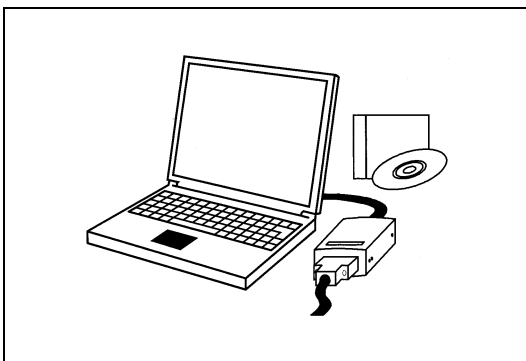
1 Inspection with PC

SAPH300021600004

1. After display of failure code, check EGR with the failure diagnosis tool (HINO field support system) using PC.
2. Connect the failure diagnosis tool (HINO field support system) using PC and set the starter key to "ON".
3. Make sure that there are no EGR solenoid valve 2 failure (DTC code P1402, P1403) and EGR lift sensor 2 failure (DTC code P0407, P0408).
4. Make sure that the actual opening follows the opening indicated on the EGR inspection screen.

Standard value : Within 5 % error

NG

EGR failure

OK

Normal

"Reference : 3-6, Failure diagnosis using DST-1, Engine ECU, Engine diagnosis code"

CLICK HERE TO **DOWNLOAD** THE COMPLETE MANUAL

- Thank you very much for reading the preview of the manual.
- You can download the complete manual from: www.heydownloads.com by clicking the link below



- Please note: If there is no response to CLICKING the link, please download this PDF first and then click on it.

CLICK HERE TO **DOWNLOAD** THE COMPLETE MANUAL