

MODELS | SJ9241 RT SJ9250 RT

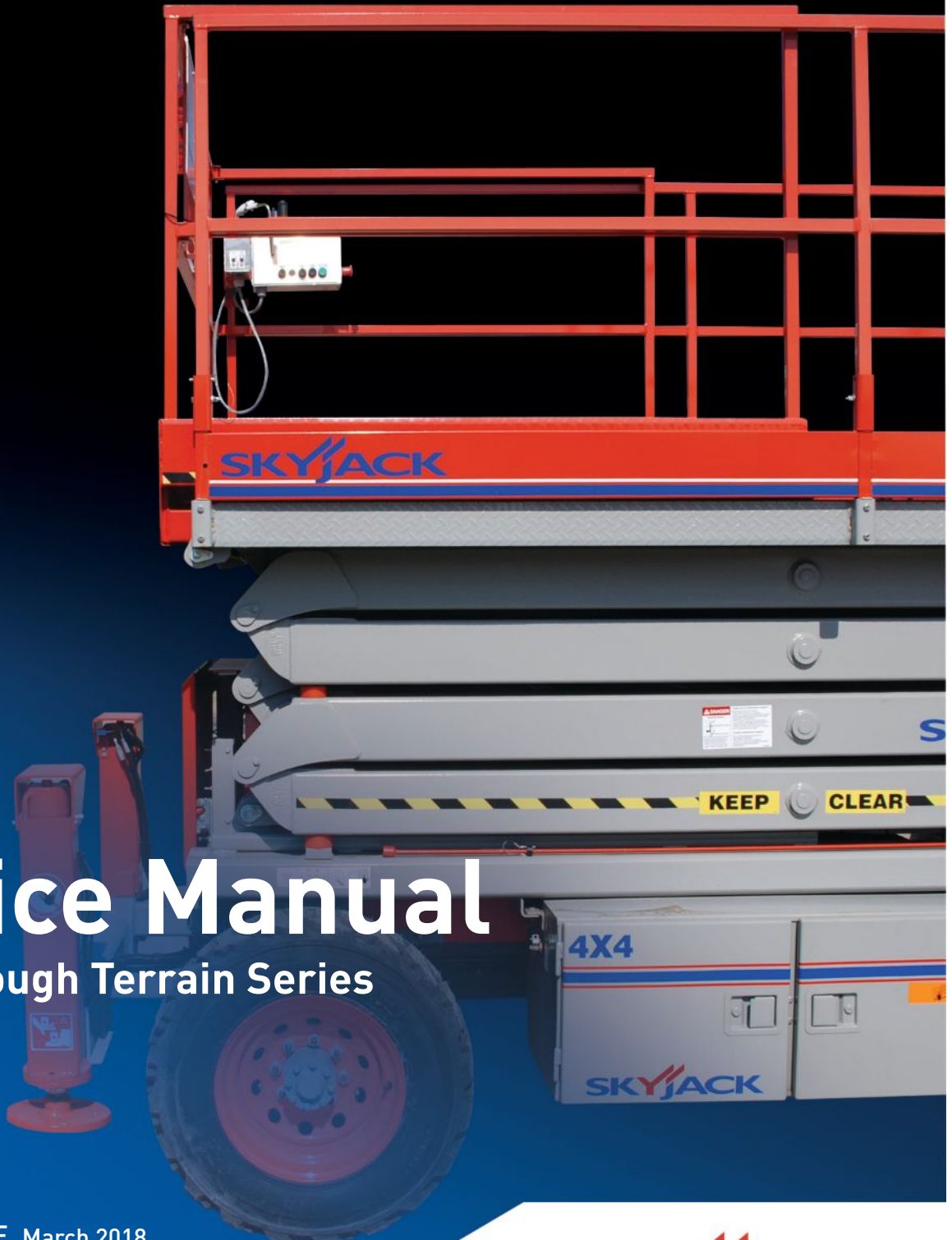

Service Manual

Full-Size Rough Terrain Series

Part No. 143905AE March 2018

SKYJACK[™]

CLICK HERE TO **DOWNLOAD** THE COMPLETE MANUAL

- Thank you very much for reading the preview of the manual.
- You can download the complete manual from: www.heydownloads.com by clicking the link below



- Please note: If there is no response to CLICKING the link, please download this PDF first and then click on it.

CLICK HERE TO **DOWNLOAD** THE COMPLETE MANUAL

Safety Precautions (Continued)

Know and understand the safety precautions before going on to next section.

- **DO NOT** operate an aerial platform that has ladders, scaffolding or other devices mounted on it to increase its size or work height. It is prohibited.



- **BE AWARE** of crushing hazards. Keep all body parts inside platform guardrail.



- **DO NOT** exert side forces on aerial platform while elevated.

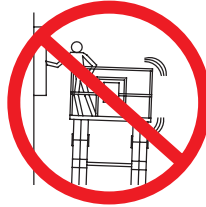

- **DO NOT** lower the platform unless the area below is clear of personnel and obstructions.



- **DO NOT** use the aerial platform as a crane. It is prohibited.



- **ENSURE** that there are no personnel or obstructions in the path of travel, including blind spots.

- **DO NOT** sit, stand or climb on the guardrails. It is prohibited.



- **BE AWARE** of blind spots when operating the aerial platform.

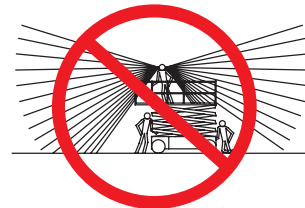

- **DO NOT** climb on scissor arm assembly. It is prohibited.



- **STUNT** driving and horseplay are prohibited.
- **ENSURE ALL** tires are in good condition and lug nuts are properly tightened.

- **BE AWARE** of overhead obstructions or other possible hazards around the aerial platform when driving or lifting.

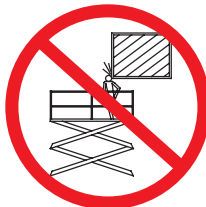

- **DO NOT** alter or disable limit switches or other safety devices.

- **DO NOT** raise the platform while the aerial platform is on a truck, fork lift or other device or vehicle.



- **DO NOT** use the aerial platform without guardrails, locking pins and the entry gate/chain/bar in place.

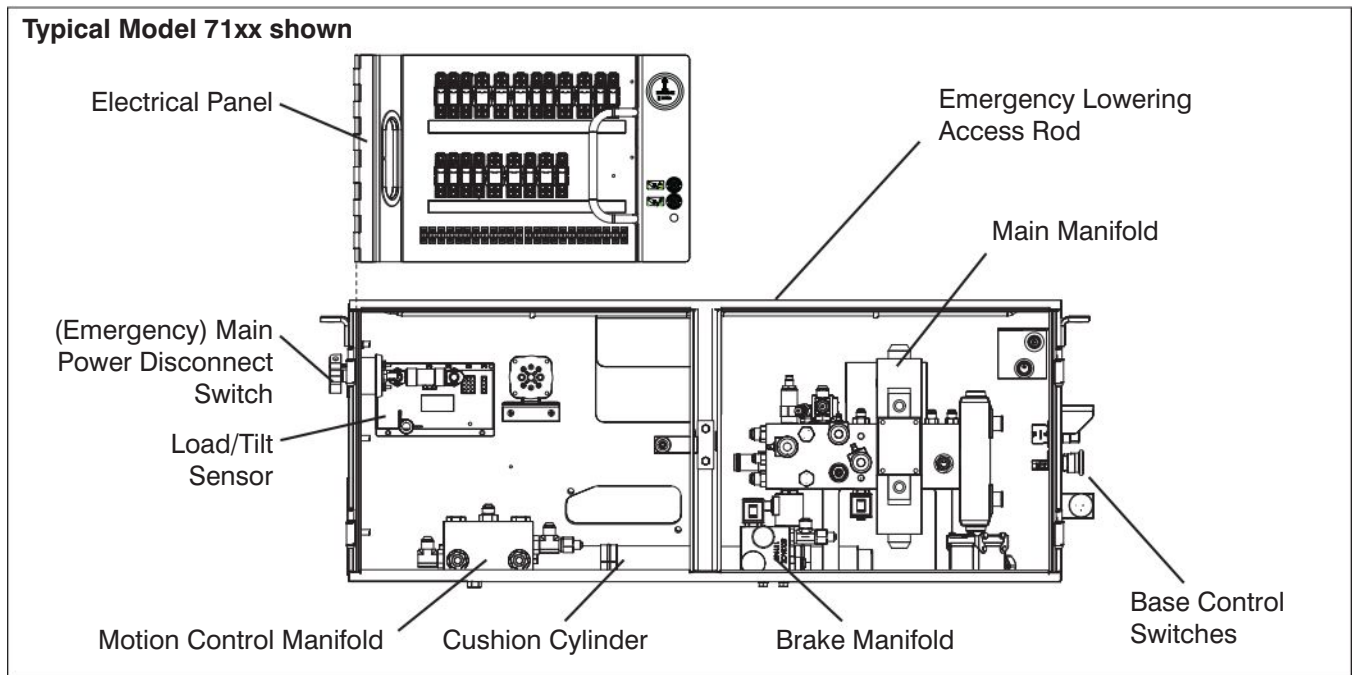

- Ensure rod is properly secured and there is no visible damage.

1.1-4 Electrical and Control Components

- Ensure all compartment latches are secure and in proper working order.
- **Main Power Disconnect Switch**
 - Turn main power disconnect switch to “○” off position.
 - Ensure all cables are secure and switch is in proper working condition.
- **Base Control Switches**
 - Ensure there are no signs of visible damage and all switches are in their neutral positions.
- **Battery**
Proper battery condition is essential to good performance and operational safety. Improper fluid levels or damaged cables and connections can result in component damage and hazardous conditions.



WARNING

Explosion hazard. Keep flames and sparks away. Do not smoke near batteries.



WARNING

Battery acid is extremely corrosive - Wear proper eye and facial protection as well as appropriate protective clothing. If contact occurs, immediately flush with cold water and seek medical attention.

1. Check battery case for damage.
2. Clean battery terminals and cable ends thoroughly with a terminal cleaning tool or wire brush.
3. Ensure all battery connections are tight.
4. If applicable, check battery fluid level. If plates are not covered by at least 1/2 in. (13 mm) of solution, add distilled or demineralized water.
5. Replace battery if damaged or incapable of holding a lasting charge.



WARNING

Use original or manufacturer-approved parts and components for the aerial platform.

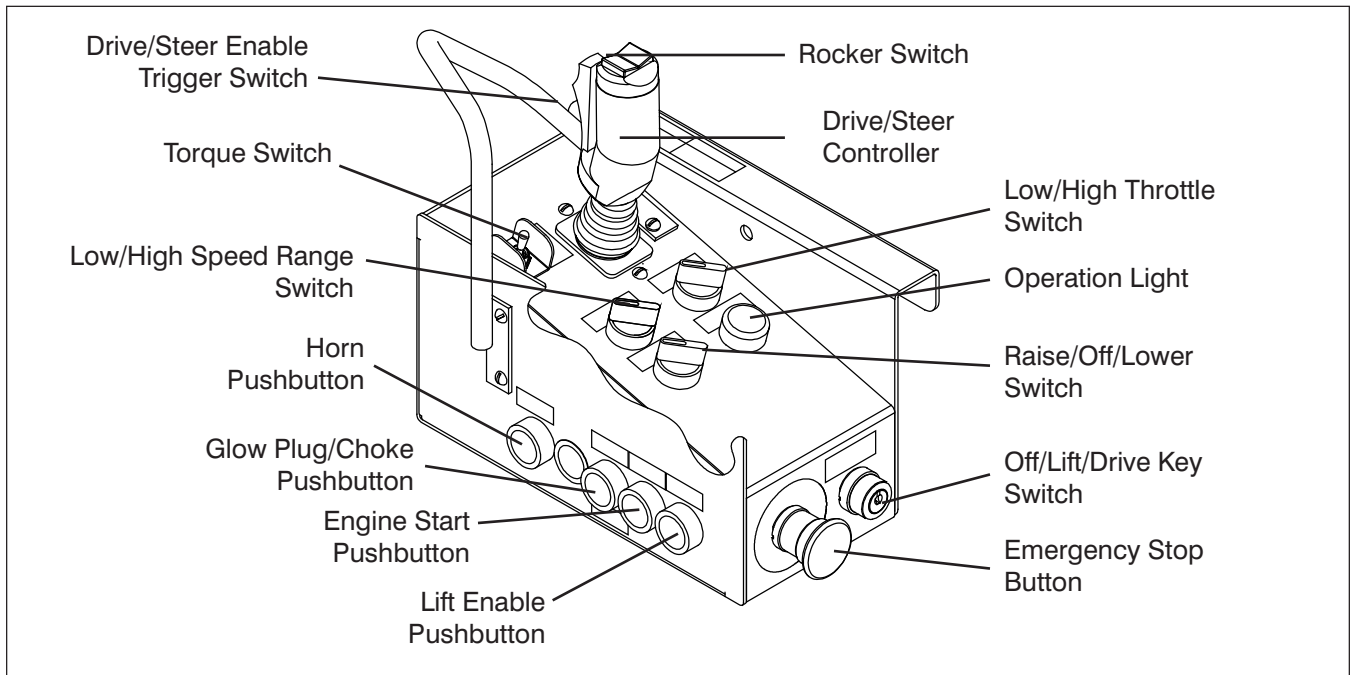
**WARNING**





If beeping sound is not audible and light does not come on, aerial platform must be tagged and placed out of service.

10. Select low/high throttle switch to “” low throttle position.

**CAUTION**

Do not start the engine in the high throttle position.

11. To start the engine:

- If (ANSI/CSA) dual fuel engine is cold, depress and hold “” choke pushbutton (if equipped) with engine “” start pushbutton to start the engine.
- If diesel engine is cold, select and hold “” glow plug pushbutton for 15 to 20 seconds or until indicator light goes off. Depress and hold “” engine start pushbutton to start the engine.

- If engine is not cold, depress and hold “” engine start pushbutton to start the engine.

- **Test Emergency Stop**

1. Push in “” emergency stop button.
Result: Engine should shut down and aerial platform functions should not operate.

- **Test Lift Enable**



1. Pull out “” emergency stop button.
2. Restart the engine.
3. Select and hold raise/off/lower switch to “” raise position without pressing lift “” enable pushbutton.
Result: Platform should not rise.









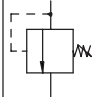



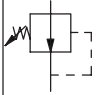



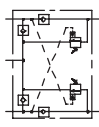







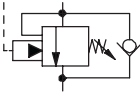

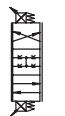



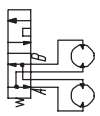





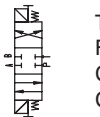





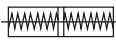

Table 2.1b Specifications and Features - CE

Model		Mid Size RTs		Full Size RTs			
		7127	7135	883 I	884 I	924 I	9250
Weight*		3724 kg	4392 kg	4554 kg	4962 kg	6718 kg	7407 kg
Width		1.82 m		2.21 m		2.34 m	
Length		3.81 m		3.5 m		4.55 m	
Platform Size		1.63 m x 2.97 m		1.73 m x 3.39 m		1.85 m x 4.39 m	
Height	Working	10.2 m	12.7 m	11.4 m	14.5 m	14.5 m	17.2 m
	Platform Elevated	8.2 m	10.7 m	9.4 m	12.5 m	12.5 m	15.2 m
	Platform Lowered	1.54 m	1.73 m	1.50 m	1.75 m	1.68 m	2 m
	Drive	Full		7.9 m		Full	7.9 m
Tires		Refer to Table 2.6 for tire specification and usage.					
Speed	Normal Drive	5.6 km/h		4.8 km/h		3.8 km/h	
	Elevated Drive	0.56 km/h		0.97 km/h		0.72 km/h	
	Raise (Rated Load)	31 sec.	38 sec.	58 sec.	56 sec.	62 sec.	64 sec.
	Lower (Rated Load)	46 sec.	43 sec.	44 sec.	53 sec.	59 sec.	86 sec.
Engine (RPM)	Kubota (Diesel)	1400 (Low) / 2800 (High)		1400 (Low) / 2800 (High)			
Gradeability		30%		30%		25%	25%

60348AI-CE-R

- * Weights are approximate; refer to serial nameplate for specific weight. Values shown are for standard 4WD aerial platforms on air tires with a manual extension platform (Models 7127 & 7135) and no extension platforms (Models 8831 & 8841). For models 9241 & 9250, values shown are for standard 4WD on foam tires with two powered extension platforms.

3.1 Hydraulic Symbol Chart

	LINE CROSSING		VARIABLE DISPLACEMENT PUMP		SHUTTLE VALV		VELOCITY FUSE
	LINE JOINED		HAND PUMP		ACCUMULATOR, GAS CHARGED		SINGLE ACTING CYLINDER
	HYDRAULIC TANK		RELIEF VALVE		CUSHION CYLINDER		DOUBLE ACTING CYLINDER
	HYDRAULIC FILTER WITH BYPASS		PRESSURE REDUCING VALVE		PRESSURE SWITCH		DOUBLE ACTING DOUBLE RODDED
	ELECTRIC MOTOR		FIXED ORIFICE		MOTION CONTROL VALVE		SPRING APPLIED HYDRAULIC RELEASED BRAKE
	ENGINE		ADJUSTABLE FLOW CONTROL		FLOW DIVIDER COMBINER		BRAKE CYLINDER
	FIXED DISPLACEMENT PUMP		CHECK VALVE		COUNTER BALANCE VALVE		ROTARY ACTUATOR
	THREE POSITION FOUR WAY PROPORTIONAL		OIL COOLER		VALVE COIL		BI DIRECTIONAL HYDRAULIC MOTOR
	SERIES PARALLEL HYDRAULIC MOTOR		TWO POSITION TWO WAY NORMALLY CLOSED		TWO POSITION THREE WAY		THREE POSITION FOUR WAY CLOSED CENTER OPEN PORT
	TWO POSITION TWO WAY NORMALLY OPEN		TWO POSITION THREE WAY		THREE POSITION FOUR WAY CLOSED CENTER CLOSED PORT		THREE POSITION FOUR WAY PROPORTIONAL
	PRESSURE TRANSDUCER		MAIN LINES Solid		PILOT LINES Dashed		VARIABLE DISPLACEMENT HYDRAULIC MOTOR
	SERVO		QUICK DISCONNECT				

3.4 Electrical Component Parts List (Continued)

Index No.	Skyjack Part No.	Qty.	Description
Parts list continued from the previous page.			
RST2	108788	1	RESISTOR, 3 Ohm/100W
S1	119726	1	SWITCH, Main Power Disconnect
S2	147054	2	TOGGLE SWITCH, Up/Off/Down (Base control console)
S3	147054	1	N.O. CONTACT, Off/Lift/Drive select key switch (Platform)
	147053	2	N.C. CONTACT, Off/Lift/Drive select key switch (Platform)
S4	147053	1	N.C. CONTACT, Emergency stop switch (Platform) (ANSI/CSA)
	147053	2	N.C. CONTACT, Off/Lift/Drive select key switch (Platform) (CE)
S5	147054	2	N.O. CONTACT, Up/Down switch (Platform)
S6	147053	1	N.C. CONTACT, Emergency stop switch (Base control console)
S7	132537	1	CONTROLLER ASSEMBLY, Drive/steer
S7-1	122869	1	• SWITCH W/ACTUATOR, 2nd Speed
S7-2	122877	1	• SWITCH, Right steer
S7-3	122877	1	• SWITCH, Left steer
S7-4	122869	1	• SWITCH W/ACTUATOR, Reverse drive
S7-5	122869	1	• SWITCH W/ACTUATOR, Forward drive
S7-6	122869	1	• SWITCH W/ACTUATOR, 3rd Speed
S7-7	122872	1	• SWITCH, Enable push button
S8	147054	1	N.O. CONTACT, Horn switch (Platform)
S9	147054	1	N.O. CONTACT, Lift enable switch (Platform)
S9A	102853	1	SWITCH, Outrigger enable
S9B	127132	1	SWITCH, Outrigger enable
S10	147054	2	SWITCH, N.O. contact (Base control console) (ANSI/CSA)
		1	SWITCH, N.O. contact (Base control console) (CE)
	147053	1	SWITCH, N.C. contact (Base control console) (CE)
S11	102853	1	TOGGLE SWITCH, Front platform extend/retract (Platform)
S11A	102853	1	TOGGLE SWITCH, Rear platform extend/retract (Platform)
S12	102853	1	SWITCH, Hydraulic Generator (Platform)
S13	147054	1	N.O. CONTACT, Choke switch or Glow plug switch (Platform)
S14	147054	1	N.O. CONTACT, Low/high throttle switch (Platform)
S15	147054	1	N.O. CONTACT, Engine start switch (Platform)
S20	102853	1	TOGGLE SWITCH, Left Front Outrigger Up/down
S20A	127132	1	SWITCH, Front left outrigger up/down toggle
S21	102853	1	TOGGLE SWITCH, Right Front Outrigger Up/down
S21A	127132	1	SWITCH, Front right outrigger up/down toggle
S22	102853	1	TOGGLE SWITCH, Right Rear Outrigger Up/down
S22A	127132	1	SWITCH, Rear right outrigger up/down toggle
S23	102853	1	TOGGLE SWITCH, Left Rear Outrigger Up/down
S23A	127132	1	SWITCH, Rear left outrigger up/down toggle
S24	102853	1	SWITCH, Auto-Level Outrigger
S29	147054	1	N.O. CONTACT, Low/high range (Platform)
S30	124446	1	SWITCH, Engine off/on (Engine panel)
Parts list continued on the following page.			

3.13 Hydraulic Schematic (Dana Axles)

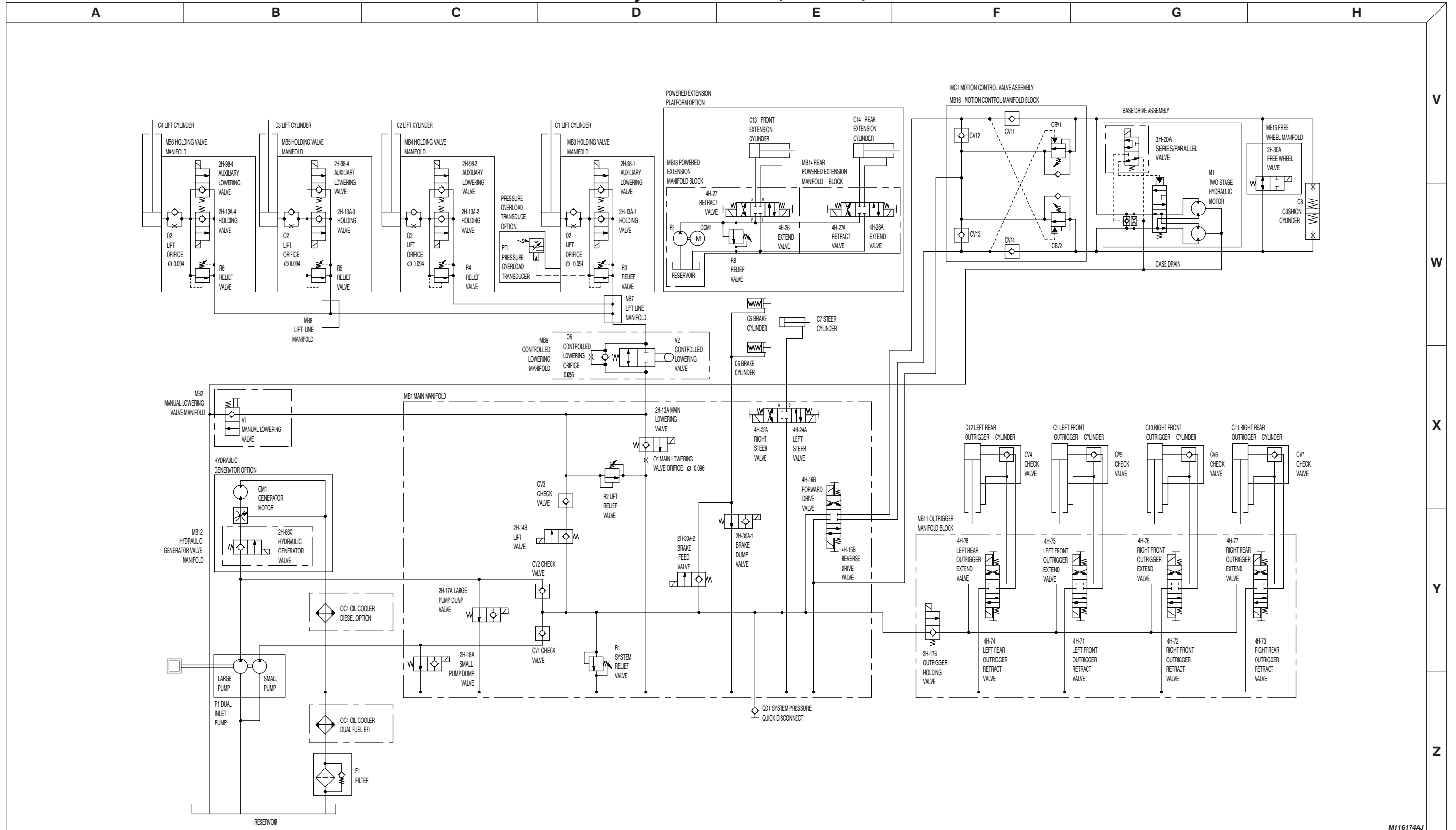

M116174AJ

CLICK HERE TO **DOWNLOAD** THE COMPLETE MANUAL

- Thank you very much for reading the preview of the manual.
- You can download the complete manual from: www.heydownloads.com by clicking the link below



- Please note: If there is no response to CLICKING the link, please download this PDF first and then click on it.

CLICK HERE TO **DOWNLOAD** THE COMPLETE MANUAL

3.23 AutoLeveling Outrigger Connection Diagram

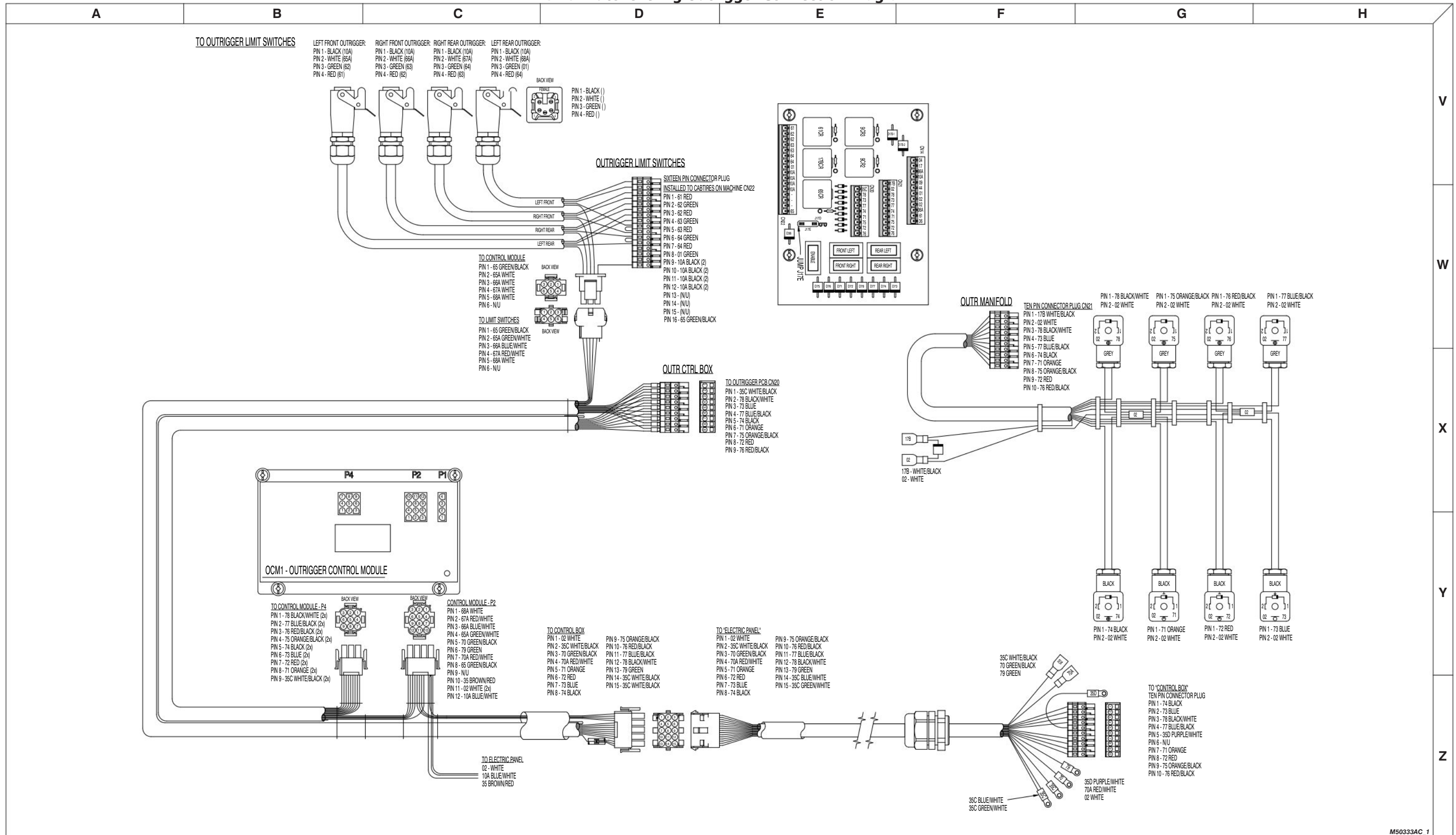

3.32 Electrical Schematic - ANSI/CSA & AS (All Option with Kubota Diesel Engine)

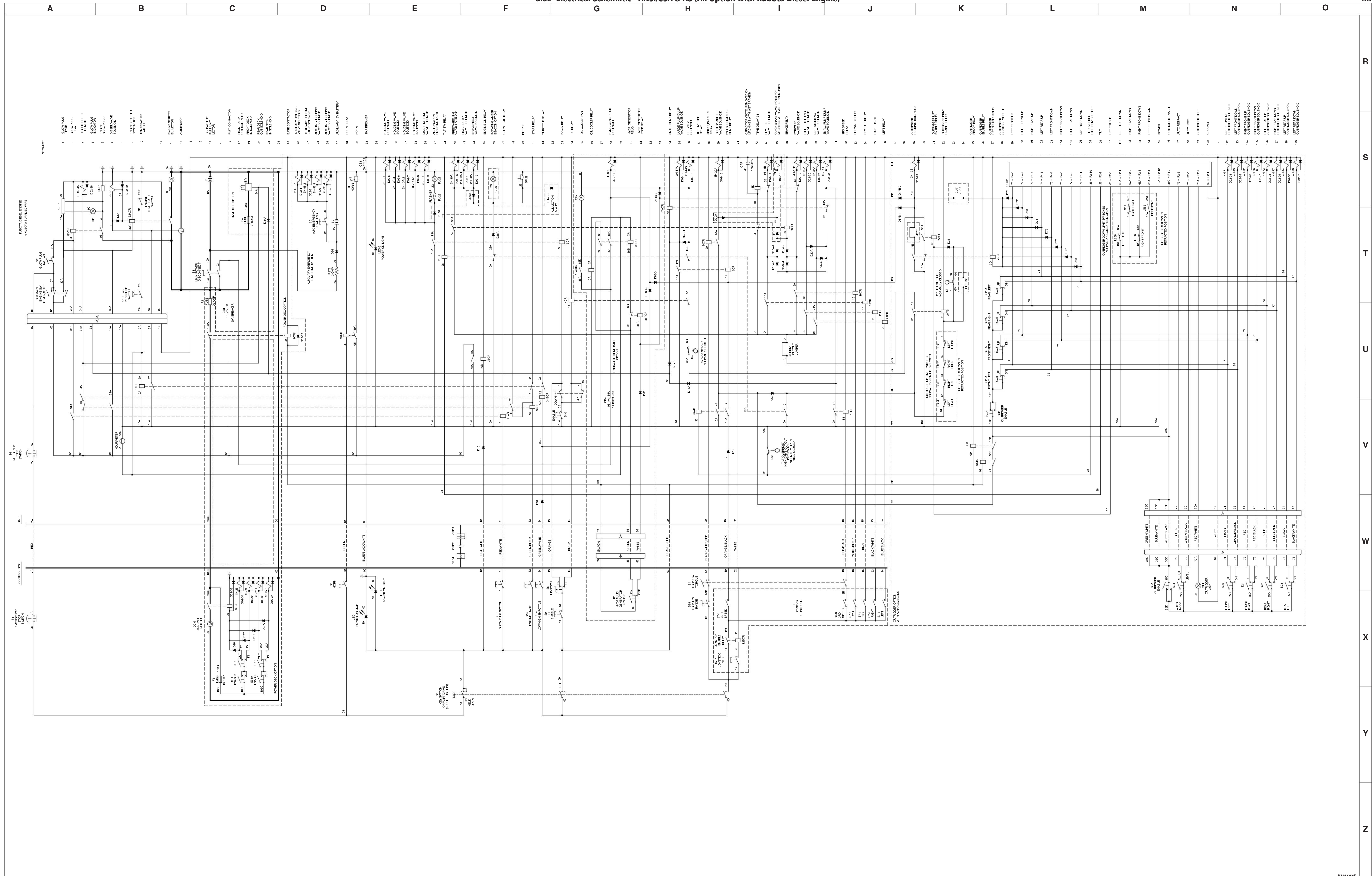

Electrical System (Continued)

5. Loose or broken wire #7C from emergency stop switch S6 to platform/base switch S10.
 - Check continuity. Replace if defective.
6. Open or defective platform/base switch S10.
 - Select platform on switch. Check switch. Replace if defective.
7. Loose or broken wire #7A from platform/base switch S10 to platform emergency stop switch S4.
 - Check continuity. Replace if defective.
8. Open or defective platform emergency stop switch S4.
 - Check switch. Replace if defective.

4.1-4 All Functions Inoperative from Platform

1. Loose or broken wire #08 from emergency stop switch S4 to off/lift/drive key switch S3.
 - Check continuity. Replace if defective.
2. Open or defective off/lift/drive key switch S3.
 - Check switch. Replace if defective.
3. Loose or broken wire #10 from off/lift/drive key switch S3 to platform terminal block.
 - Check continuity. Replace if defective.
4. Loose or broken wire #10 from platform terminal block to diode D10 located at relay 10BCR1.
 - Check continuity. Replace if defective.
5. Open diode D10 or diode D10 is not connected at relay 10BCR1.
 - Check diode. Replace if defective.

All Functions Inoperative (Additional for machines with Load Sensing System) (CE)

1. Loose or broken wire #10C from base terminal strip to control module CM1 at pin #P2-12.
 - Check for 12 Volts at P2-12. If no voltage present, check wire continuity. Replace if defective.
2. Loose or broken wire #28 from control module CM1 at pin #P3-4 to 28CR1 tilt relay and 28CR2 Down Enable Relay.
 - Check for 12 Volts at P3-4. If voltage present, check for 12 Volts at wire #28A on outrigger connector plug CN-14 at pin #1. If voltage present, check for 12 Volts on wire #28A at 28ACR1 Relay and 28ACR2 Relay. If voltage present, check operation of relays. If no voltage present, check wire continuity. Replace if defective.
3. Loose or broken wire #28E from control module CM1 at pin #P3-6 to 28ECR1 auxiliary tilt relay and 28ECR2 auxiliary down enable relay.
 - Check for 12 Volts at P3-6. If voltage present, check for 12 Volts at wire #28E at 28ECR1 and 28ECR2 relays. If voltage present, check operation of relays. If no voltage present, check wire continuity. Replace if defective.
4. Defective pressure transducer PT1 or angle transducer AT1 or related wiring.
 - Refer to transducer troubleshooting charts.

4.1-5 Engine will Not Crank from Platform

1. Open or defective key switch S3.
 - Check switch. Replace if defective.
2. Loose or broken wire #10 from key switch S3 to start switch S15.
 - Check continuity. Replace if defective.
3. Defective start switch S15.
 - Check switch. Replace if defective.
4. Loose or broken wire #32 from start switch S15 to relay 32CR.
 - Check continuity. Replace if defective.
5. Defective relay 32CR.
 - Check relay. Replace if defective.

Electrical System (Continued)

6. Loose or broken wire #02 from relay 16CR to base terminal block.
 - Check continuity. Replace if defective.
7. Loose or broken wire #04 from base terminal block to relay 16CR.
 - Check continuity. Replace if defective.
8. Loose or broken wire #16A from relay 16CR to time delay relay 1TD.
 - Check continuity. Replace if defective.
9. Defective time delay relay 1TD.
 - Check relay. Replace if defective.
10. Loose or broken wire #16B from time delay relay 1TD to forward valve coil 4H-16B.
 - Check continuity. Replace if defective.
11. Defective forward valve coil 4H-16B.
 - Check coil. Replace if defective.
12. Loose or broken wire #02 from forward valve coil 4H-16B to base terminal block.
 - Check continuity. Replace if defective.
13. Open diode D16A-1 or D16A-2.
 - Check diodes. Replace if defective.

4.1-23 First Drive Speed and Steering Inoperative

1. Loose or broken wire #21 from base terminal block to relay 17ACR. (ANSI/CSA only)
 - Check continuity. Replace if defective.
1. Loose or broken wire #21 from diode D24A to relay 17ACR. (CE only)
 - Check continuity. Replace if defective.
2. Defective relay 17ACR.
 - Check relay. Replace if defective.
3. Loose or broken wire #18A from relay 17ACR to small pump dump valve solenoid 2H-18A.
 - Check continuity. Replace if defective.
4. Defective small pump dump valve coil 2H-18A.
 - Check coil. Replace if defective.
5. Loose or broken wire #02 from small pump dump solenoid 2H-18A to base terminal block.
 - Check continuity. Replace if defective.

4.1-24 Second Drive Speed Inoperative

1. Defective second speed switch S7-1 in joystick S7.
 - Check switch. Replace if defective.
2. Defective joystick S7.
 - Check joystick. Replace if defective.
3. Loose or broken wire #19 from controller S7-1 to platform terminal block.
 - Check continuity. Replace if defective.
4. Loose or broken wire #19 from platform terminal block to diode D19 at relay 35CR.
 - Check continuity. Replace if defective.
5. Loose or Open diode D19.
 - Tighten diode. Check diode. Replace if defective.
6. Loose or broken wire #10A from base terminal block to high drive/tilt override limit switch LS5.
 - Check continuity. Replace if defective.
7. Misadjusted or defective high drive/tilt override limit switch LS5.
 - Adjust switch. Replace if defective.
8. Loose or broken wire #35 from high drive/tilt override limit switch LS5 to base terminal block.
 - Check continuity. Replace if defective.
9. Loose or broken wire #35 from base terminal block to relay 35CR.
 - Check continuity. Replace if defective.

Electrical System (Continued)

15. Loose or broken wire #3 from circuit breaker CB4 to circuit breaker CB1.
 - Check continuity. Replace if defective.
16. Loose or broken wire #86C from relay 86BCR to generator valve coil 2H-86C.
 - Check continuity. Replace if defective.
17. Loose or broken wire #02 from base terminal block to generator valve coil 2H-86C.
 - Check continuity. Replace if defective.
18. Defective generator valve coil 2H-86C.
 - Check coil. Replace if defective.

4.1-39 Hydraulic Generator will Not Shut Off from Generator Switch

1. Defective generator switch S12.
 - Check switch. Replace if defective.
2. Loose or broken wire #86 from generator switch S12 to diode D86.
 - Check continuity. Replace if defective.
3. Open diode D86.
 - Check diode. Replace if defective.
4. Defective relay 86ACR.
 - Check relay. Replace if defective.
5. Loose or broken wire #02 from base terminal block to relay 86ACR.
 - Check continuity. Replace if defective.

4.1-40 All Outriggers Inoperative (Auto-level and manual)



WARNING

Scissors lift must be below high speed limit switch for outriggers to function.

NOTE

For the outriggers to function the upper control console must be in the lift position.

1. No power on wire #44 at relay 35CR.
 - If no power is present ensure there is power on wire #35 and relay 35CR operates correctly.
2. Loose or broken wire #44 from relay 35CR to pin #6 on connector CN14 on outrigger board.
 - Check for continuity. Replace if defective.
3. No power at wire #9 at pin #5 on connector CN14 on outrigger board.
 - If no power is present check for continuity on wire #9 back to base terminal block TB-1. Replace if defective.
4. Defective relay 9CR2 or 9CR3 on outrigger board.
 - Check relays. Replace if defective.
5. Defective relay 17DCR on outrigger board.
 - Check relay. Replace if defective.
6. Open or broken jumper J17E on outrigger board.
 - Check jumper. Replace if defective.
7. Open diode D17B-1 on outrigger board.
 - Check diode. Replace if defective.
8. Loose or broken wire #17 from pin #2 on connector CN14 on outrigger board to relay 35CR or relay 17CR.
 - Check for continuity. Replace if defective.

Load Sensing System - CE

4.3-1 Flash Code F01: Check HWFS

1. This message is given if the GP102 startup tests have not completed.
 - Check [HELP](#) message for more information.

4.3-2 Flash Code F02: Not Ground Mode

1. This message is given if the machine is not in ground mode, P2-2 must be high.
 - Calibration can only be carried out in ground mode.

4.3-3 Flash Code F03: Not Stopped

1. This message is given if the machine is not in ground mode, P2-2 must be high.
 - Check [DIAGNOSTICS / SWITCHES](#) to see which function switch is closed.

4.3-4 Flash Code F04: Tilted

1. This message is given if the machine is tilted.
 - Calibration must be carried out with the machine level. If the machine is level, use the [SETUPS / TILT SETUPS](#) to set the GP102 level.

4.3-5 Flash Code F05: Bad Height

1. This message is given if the height sensor output P4-3 is out of range at the start of calibration.
 - The height sensor output must be between 1.0V and 4.0V. Check [DIAGNOSTICS / SENSORS](#) to see the output. A reading of 0V or 5V is probably due to a wiring problem.

4.3-6 Flash Code F06: Check Elev

1. This message is given if the elevation switch P2-10 is open at the start of calibration, when the operator has confirmed the "PLATFORM DOWN?" question.
 - If the platform is down, check the elevation switch wiring.

4.3-7 Flash Code F08: Check Elev

1. This message is given if the elevation switch P2-10 is closed at the end of the DYNAMIC lift, when the platform should be fully raised.

This message would occur if the UP switch was accidentally opened near the start of the DYNAMIC lift.

- If the platform is fully raised, check the elevation switch wiring.

4.3-8 Flash Code F09: Bad Height

1. This message is given if the height sensor output P4-3 is out of range at the start of the DYNAMIC lift.
 - The height sensor output must be between 1.0V and 4.0V. Check [DIAGNOSTICS / SENSORS](#) to see the output.

4.3-9 Flash Code F10: Bad Height

1. This message is given if the height sensor output P4-3 is out of range at the end of the DYNAMIC lift.
 - The height sensor output must be between 1.0V and 4.0V. Check [DIAGNOSTICS / SENSORS](#) to see the output. A reading of 0V or 5V is probably due to a wiring problem.

4.3-10 Flash Code F11: Not Up

1. This message occurs at the start of the DYNAMIC lift if the operator selects a function other than UP.
 - Select the UP function.

Diagram 5.3 Multiple Disc Brake Assembly

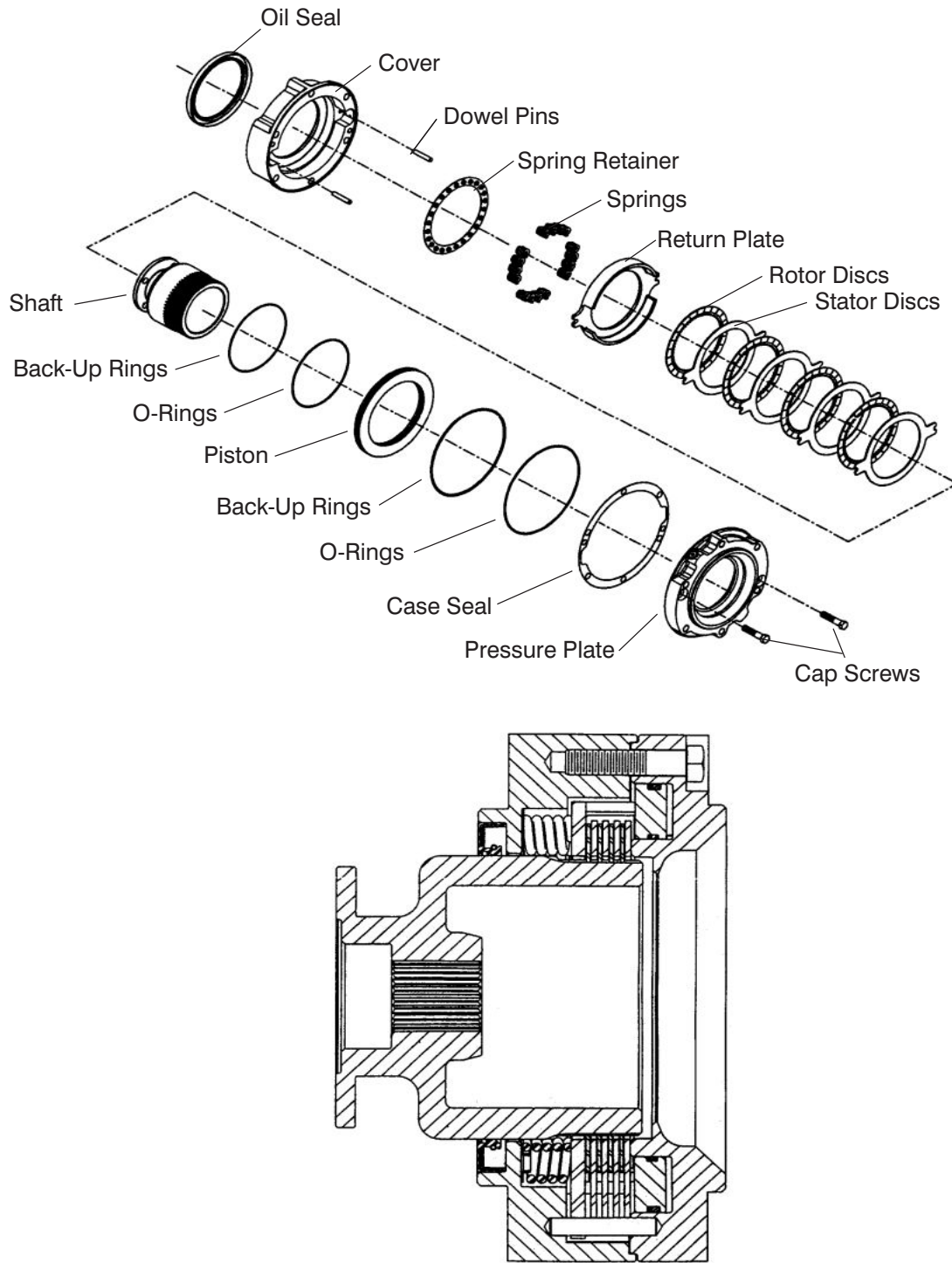

M11512AA

- i. The green LED will turn on solid.
Results: The switch is ready for normal operation.

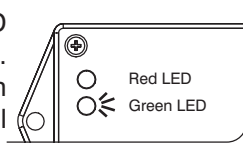

- 9. Turn main disconnect switch to “O” off position.
- 10. Push in “” emergency stop buttons.
- 11. Remove chock or wheel blocks.
- 12. Proceed to Test and Verify Tilt Circuit.

Test and Verify Tilt Circuit

Light Indicators

Set up button is located on this face next to harness

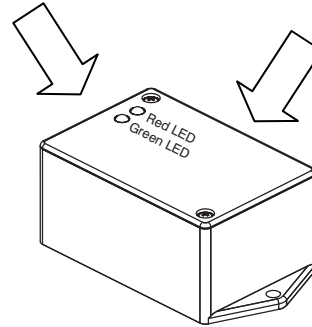

Operations of Tilt Switch

The following describes the LED’s and what they indicate.

Green LED	Illuminated whenever both tilt axes are within the specified degrees of the zero/ home learned position. Flashes when transitioning in or out of tilt angle limits, but built in time delay has not fully occurred.
Red LED	Illuminated whenever tilt on one or more axes is more than the specified degrees out from the zero/ home position.
Green & Red LED	On together, no blinking when fault detected.

Tilt Circuit Test

- 1. Refer to section 2 for test tilt sensor procedure.

5.3-3 Auto-Leveling Outrigger Setting and Error Codes

Reading the Codes:

In order to read the fault codes, a sequence of pauses and flashes can be seen on the LED mounted on the outrigger control module. The codes are continuously displayed by the LED until the fault is cleared, the outrigger control module is reset and no longer detects the fault, or idle timeout becomes active.

The sequence is as follows:

1. Half second flashes followed by half second pauses indicate the first digit.
2. A 2.5 second pause.
3. Half second flashes followed by half second pauses indicate the second digit
4. A 5 second pause.

Repeat steps 1-4

Since the outrigger control module only reports one error, only one code can be read from the LED per instance. If the error is cleared and another error is present, it will then be presented.

LED Error Codes

EVERYTHING OK	ON
VEHICLE TILTED	1/1
OUTRIGGERS CANNOT BE MOVED!	1/2
OUTRIGGERS NOT HOME	2/2
NOT FULLY LEVEL	2/1
RELEASE OUTRIGGER DEMAND!	5/5
CHECK OUTRIGGER SUPPLY (P4-9)	5/2
CANNOT LEVEL : BAD TILT SENSOR	7/1
OUTRIGGERS MANUALLY CONTROLLED!	6/6
TESTING HWFS	7/8
B+ SUPPLY TOO LOW	5/1
STARTUP!	7/7
FAULT: BAD SLAVE MICRO	7/5
FAULT: BAD TILT SENSOR	7/1
FAULT: BAD HWFS	7/2
FAULT: P2-5 FAULTY	8/1
FAULT: P2-6 FAULTY	8/2
FAULT: P2-8 STUCK ON	8/3
FAULT: P2-8 ALWAYS ON	8/4
FAULT: P2-8 ALWAYS OFF	8/5
FAULT: HWFS STALLED!	7/6

60402AB

5.4-4 LED Error Codes - Code Breakdown Chart (Continued)

Vehicle Tilted	11
Vehicle Overloaded	12
Too High - Drive Prevented	14
Too High - Lift Up Prevented	15

These are not true faults but an indication that vehicle movement is prevented. Remove excessive load from the platform. Lower the platform if close to maximum height. Move the vehicle to level ground.

Invalid Height - Check Sensor	65
-------------------------------	----

Check the voltage out of the height transducer, into P4-3. It should be between .4V and 4.6V and should vary as the platform position varies.

Testing HWFS	78
Start Up!	77

These are not true faults unless they do not clear – the start-up tests should only occur for a short time.

Overload Functions Disabled!	66
Factory Override	67

These are not true faults – the GP102 has been configured to suppress overload functionality.

Idle Timeout Active!	Always Off
Fault: Bad Tilt Sensor	71
Fault: Bad HWFS	72
Fault: Bad Slave Analogs	73
Fault: Bad Strain Monitors	74
Fault: Bad Slave Micro	75
Fault HWFS Stalled!	76

Action a function to clear the idle timeout if it occurred. Ensure the GP102 is correctly mounted – incorrect mounting can cause the “bad tilt sensor” diagnostic to occur. Otherwise there may be an internal problem with the GP102.

CLICK HERE TO **DOWNLOAD** THE COMPLETE MANUAL

- Thank you very much for reading the preview of the manual.
- You can download the complete manual from: www.heydownloads.com by clicking the link below



- Please note: If there is no response to CLICKING the link, please download this PDF first and then click on it.

CLICK HERE TO **DOWNLOAD** THE COMPLETE MANUAL