



SERVICE MANUAL

ARTICULATING BOOMS

MODEL SJ63AJ



167275AG November 2018

SKYJACK

CLICK HERE TO **DOWNLOAD** THE COMPLETE MANUAL





- Thank you very much for reading the preview of the manual.
- You can download the complete manual from: www.heydownloads.com by clicking the link below



- Please note: If there is no response to CLICKING the link, please download this PDF first and then click on it.



CLICK HERE TO **DOWNLOAD** THE COMPLETE MANUAL

Table 1.1 Owner's Annual Inspection Record

										
 Model Number: _____ Serial Number: _____										
*		20__	20__	20__	20__	20__	20__	20__	20__	20__
**										

1001AB

This decal is located on the control compartment cowling. It must be completed after an annual inspection has been completed. Do not use the aerial platform if an inspection has not been recorded in the last 6 months.

	Pictorial	Description
*		Inspection Date
**		Inspector Signature

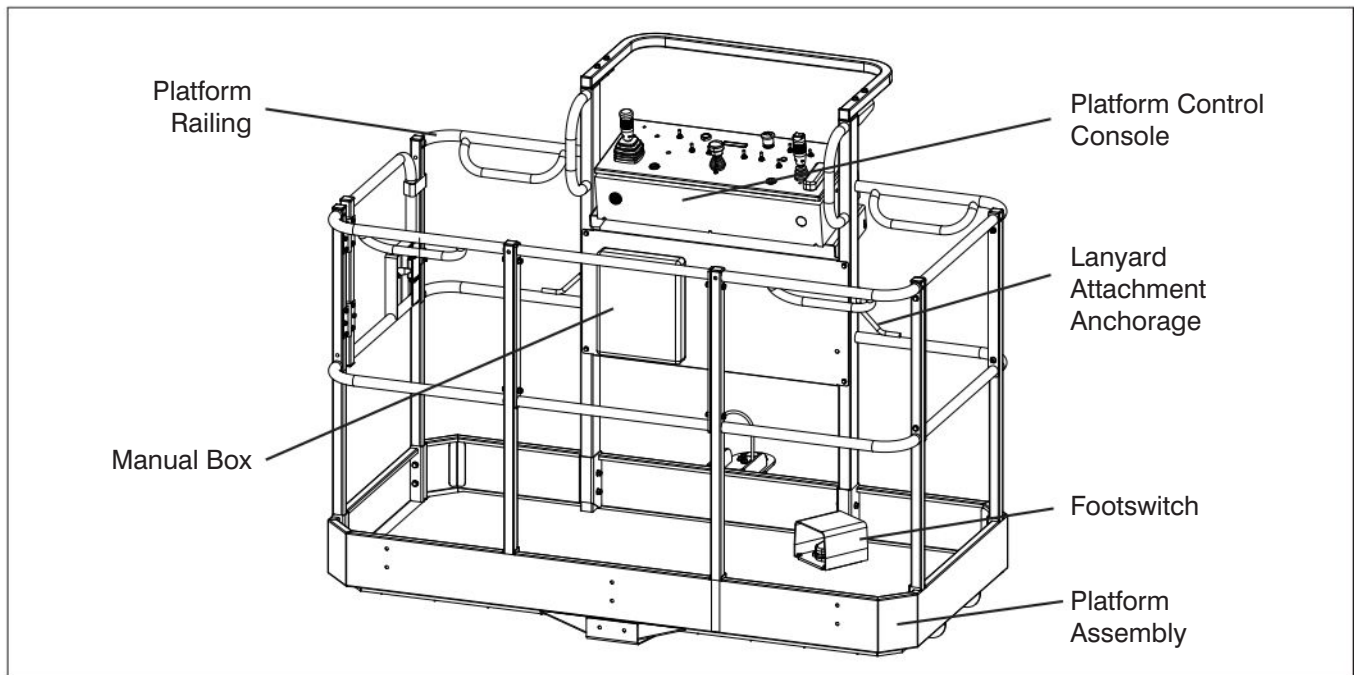

1.1-7 Platform Assembly (B)

- Ensure there are no loose or missing parts and there is no visible damage.
- Ensure all fasteners are securely in place.
- Ensure all railings are properly positioned and secured.
- Ensure gate/drop-bar(s) are in good working order.
- Ensure footswitch is in good working order and has not been modified, disabled or blocked.
- Ensure lanyard attachment anchorages are secure and there is no visible damage.

1.1-8 Platform Control Console (B)

- Ensure all switches/controllers are returned to neutral and are properly secured.
- Ensure there are no loose or missing parts and there is no visible damage.

Table 2.5 Torque Specifications for Fasteners (Metric)

METRIC BOLT TORQUE CHART					
Size	Torque Units	8.8		10.9	
		Dry	Lubed	Dry	Lubed
M5 x 0.80	(in-lb)	(54)	(41)	(78)	(59)
	Nm	6.1	4.6	8.8	6.7
M6 x 1.00	(in-lb)	(92)	(69)	(133)	(99)
	Nm	10.4	7.8	15	11.2
M7 x 1.00	(in-lb)	(156)	(116)	(222)	(167)
	Nm	17.6	13.1	25.1	18.9
M8 x 1.25	(in-lb)	(225)	(169)	(333)	(242)
	Nm	25.4	19.1	37.6	27.3
M10 x 1.50	ft-lb	37	28	53	40
	Nm	50	38	72	54
M12 x 1.75	ft-lb	65	49	93	69
	Nm	88	66	126	94
M14 x 2.00	ft-lb	104	78	148	111
	Nm	141	106	201	150
M16 x 2.00	ft-lb	161	121	230	172
	Nm	218	164	312	233
M18 x 2.50	ft-lb	222	167	318	238
	Nm	301	226	431	323
M20 x 2.50	ft-lb	314	235	449	337
	Nm	426	319	609	457
M22 x 2.50	ft-lb	428	321	613	460
	Nm	580	435	831	624
M24 x 3.00	ft-lb	543	407	776	582
	Nm	736	552	1052	789
M27 x 3.00	ft-lb	796	597	1139	854
	Nm	1079	809	1544	1158
M30 x 3.50	ft-lb	1079	809	1543	1158
	Nm	1463	1097	2092	1570
M33 x 3.50	ft-lb	1468	1101	2101	1576
	Nm	1990	1493	2849	2137
M36 x 4.00	ft-lb	1886	1415	2699	2024
	Nm	2557	1918	3659	2744
Inch-Pound Force = in-lb Foot-Pound Force = ft-lb Newton-Meter = Nm					

NOTE: Lubed includes lubricants such as lubricating oil, grease or uncured Loctite.

Section 3 SYSTEM COMPONENT IDENTIFICATION AND SCHEMATICS

Table of Contents

Charts

3.1 Hydraulic Symbol Chart.....	43
3.2 Electrical Symbol Chart	44
3.3 Wire Number and Color Code.....	45

Parts Lists

3.4 Hydraulic Schematic Parts List	46
3.5 Electrical Component Parts List.....	49

Diagrams and Schematics

3.6 Rotary Manifold and Port Identifications.....	52
3.7 Brake Manifold and Port Identifications.....	53
3.8 Drive and System Pump and Port Identifications.....	54
3.9 Drive Motor and Port Identifications	55
3.10 Jib Valve and Port Identifications.....	56
3.11 Main Manifold and Port Identifications	57
3.12 Main Manifold and Electrical Identifications	58
3.13 Main Manifold and Hydraulic Identifications	59
3.14 Main Electrical Harness and Fuel Level Switch Harness	60
3.15 ECU Engine Wiring Diagram (Deutz Diesel Engine).....	61
3.16 Glow Plug Harnesses (Deutz D2011 Diesel Engine)	62
3.17 Glow Plug Harnesses (Deutz D2.9L Diesel Engine).....	63
3.18 Engine Interface Harness (GM Dual Fuel Engine)	64
3.19 Engine Interface Harness (Deutz TD2.9L Diesel Engine)	65
3.20 Lowering Throttle Valve Harness	66
3.21 Harnesses	67
3.22 Platform Control Cable Harnesses	68
3.23 Limit Switch Connections at Base Control Console.....	69
3.24 Load Sensing Cable Connection (CE & AS)	70
3.25 All Motion Alarm Option Connections (CE & AS).....	71
3.26 SGE Wiring Diagram.....	72
3.27 Hydraulic Generator and Oil Cooler Wiring - Base Control Box	73
3.28 Generator Wiring - Upper Control Box	74
3.29 Welder Option Wiring (ANSI/CSA)	75
3.30 Telematics Wiring Diagram	76
3.31 Hydraulic Schematic.....	77
3.32 Platform Control Console Diagram (ANSI/CSA - GM Dual Fuel Engine).....	78
3.33 Platform Control Console Diagram (ANSI/CSA - Deutz Diesel Engine)	79
3.34 Platform Control Console Diagram (CE - Deutz Diesel Engine)	80
3.35 Platform Control Console Diagram (AS - Deutz Diesel Engine)	81
3.36 Base Control Console Diagram (ANSI/CSA - GM Dual Fuel Engine).....	82
3.37 Base Control Console Diagram (ANSI/CSA - Deutz D2.9L Diesel Engine)	83
3.38 Base Control Console Diagram (ANSI/CSA - Deutz D2011 Diesel Engine)	84
3.39 Base Control Console Diagram (CE - Deutz TD2.9L Diesel Engine).....	85
3.40 Base Control Console Diagram (CE - Deutz D2011 Diesel Engine).....	86
3.41 Base Control Console Diagram (AS - Deutz D2011 Diesel Engine)	87
3.42 Electrical Schematic Diagram (ANSI/CSA - GM Dual Fuel Engine).....	88

3

3.5 Electrical Component Parts List (Continued)

Index No.	Skyjack Part No.	Qty.	Description
			Parts list continued from previous page.
PL5	138229	1	MODULE, Upper indicating
PL6	148971	1	LIGHT, Pilot (Platform control console)
R1	139088	1	RESISTOR (6 OHM 25 Watt)
R2	151643	1	RESISTOR (250 OHM 1 Watt) (ANSI/CSA)
R5	117366	1	RESISTOR (150 OHM 2 Watt, axial lead)
R6	144492	1	RESISTOR (680 OHM 1 watt, axial lead 2%) (CE&AS)
R7	144492	1	RESISTOR (680 OHM 1 watt, axial lead 2%)
S1	119725	1	SWITCH, Main power disconnect
S2	138277	1	KEYSWITCH, Base/Off/Platform (Base control console) (ANSI/CSA)
	144366	1	KEYSWITCH, Base/Off/Platform (Base control console) (CE&AS)
S3	147053	1	N.C. CONTACT, Emergency stop (Base control console)
S4	147053	2	N.C. CONTACT, Emergency stop (Platform control console)
S5	138278	1	SWITCH, Ignition/emergency pump toggle (Base control console)
S6	138278	1	SWITCH, Ignition/emergency toggle (Platform control console)
S8	102853	1	SWITCH, Diagnose toggle (Base control console) (Deutz engine)
S9	124446	1	SWITCH, Ignition (Platform control console)
S10	115574	1	SWITCH, Throttle toggle (Platform control console)
S11	138721	1	ASSEMBLY, Footswitch
S12	138278	1	SWITCH, Boom up/down toggle (Base control console)
S13	102853	1	SWITCH, Turret rotate toggle (Base control console)
S14	102853	1	SWITCH, Telescope in/out toggle (Base control console)
S15	102853	1	SWITCH, Platform leveling toggle (Base control console)
S16	138278	1	SWITCH, Platform rotate toggle (Base control console)
S17	102853	1	SWITCH, Jib up/down toggle (Base control console)
S18	138278	1	SWITCH, Telescope in/out toggle (Platform control console)
S19	138278	1	SWITCH, Platform leveling toggle (Platform control console)
S20	138278	1	SWITCH, Platform rotate toggle (Platform control console)
S21	138278	1	SWITCH, Jib up/down toggle (Platform control console)
S23	147054	1	N.O. CONTACT, Horn (Platform control console)
S25	138278	1	SWITCH, Riser boom up/down toggle (Base control console)
S26	115574	1	SWITCH, Fuel select (Platform control console) (GM engine)
S28	148998	1	SWITCH, Differential (Platform control console)
S48	115747	1	SWITCH, Drive torque toggle (Platform control console)
X22	138576	1	PORT, Diagnose (Deutz engine)
X23	138575	1	CONNECTOR, Engine (Deutz engine)

3.15 ECU Engine Wiring Diagram (Deutz Diesel Engine)

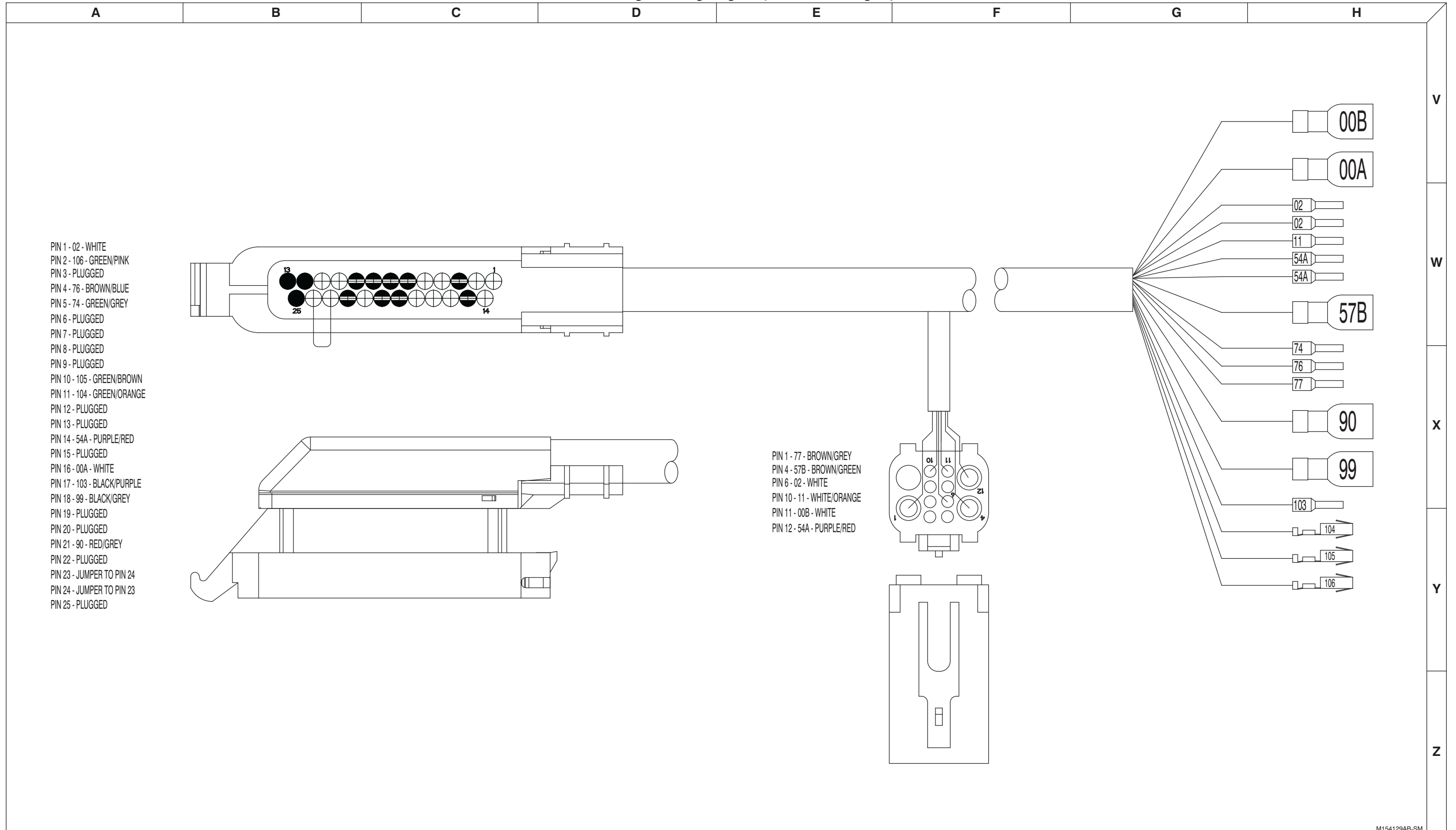

M154129AB-SM

3.25 All Motion Alarm Option Connections (CE & AS)

A B C D E F G H

V
W
X
Y
Z

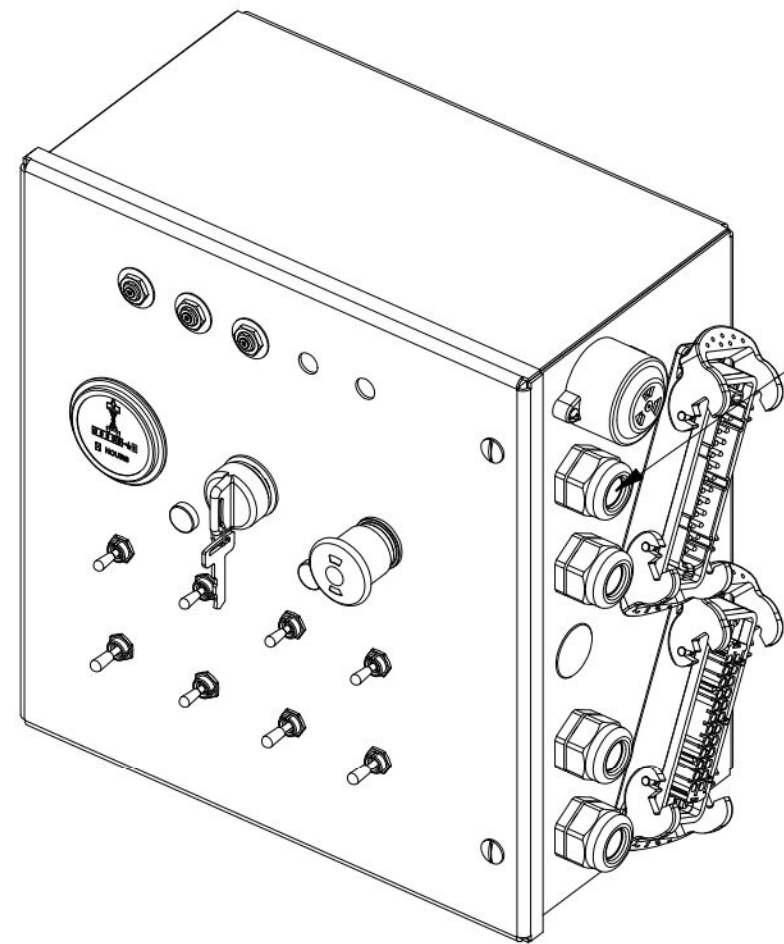

PASS WIRES THROUGH
TOP-MOST STRAIN RELIEF
(LOOSEN GLAND FIRST)

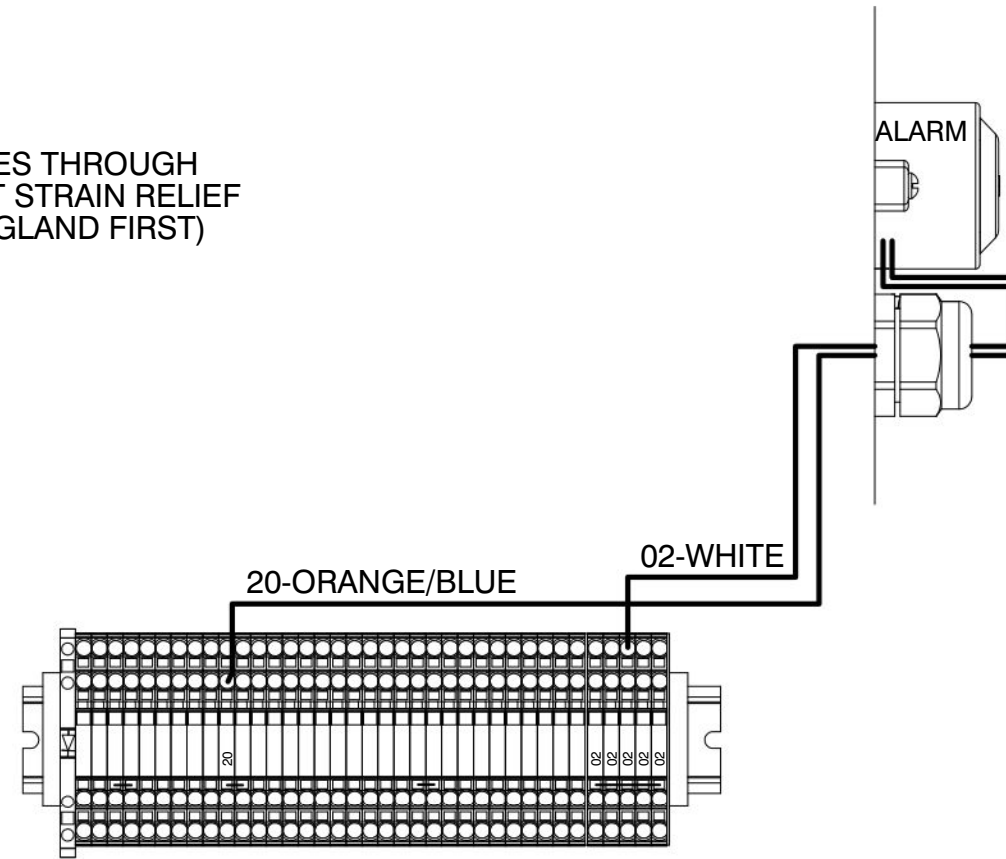

-WIRE INSTALLATION-

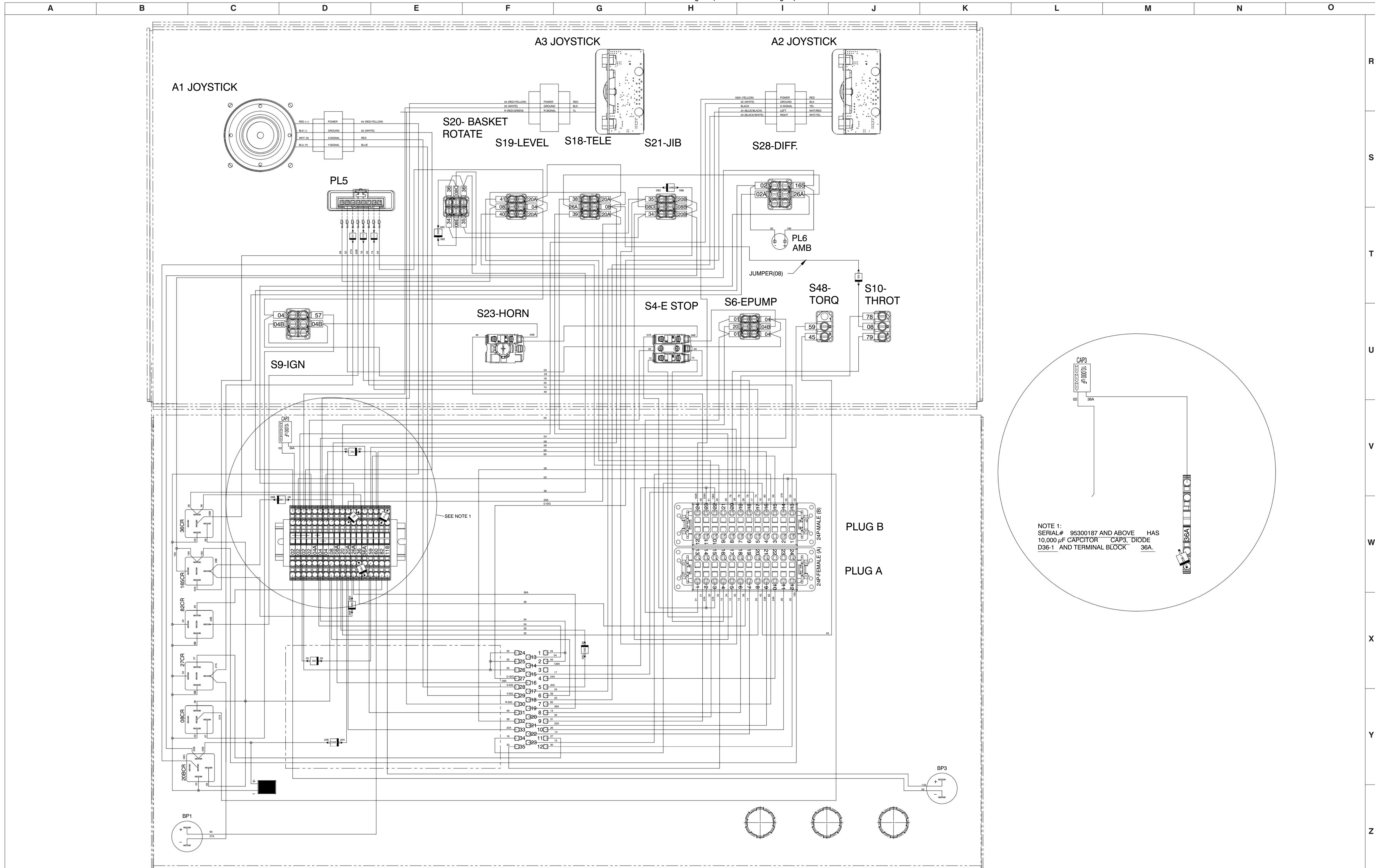

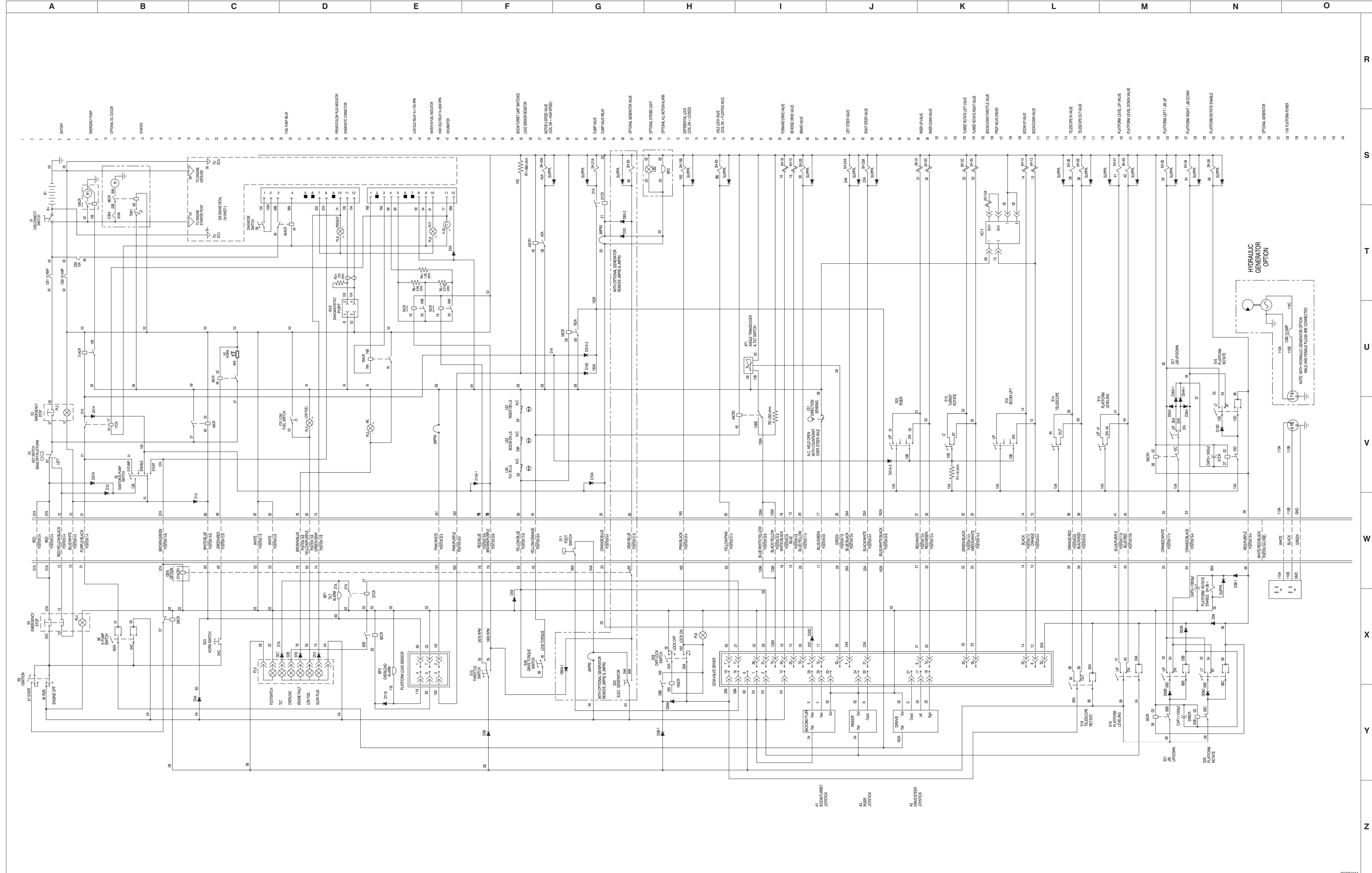

Introduction

The following pages contain a table of Troubleshooting Information for locating and correcting most service trouble which can develop. Careful and accurate analysis of the systems listed in the table of Troubleshooting Information will localize the trouble more quickly than any other method. This manual cannot cover all possible troubles and deficiencies that may occur. If a specific trouble is not listed, isolate the major component in which the trouble occurs, isolate whether the problem is electrical or hydraulic, and then isolate and correct the specific problem.

The content of this section is separated into “probable cause” and “remedy.” The information preceded by a number represents the “probable cause.” The following line, noted by a dash represents the “remedy” to the “probable cause” directly above it. See example below for clarification.

1. Probable Cause
 - Remedy

4.1a-17 No Riser Up from Base Control Console

1. Loose or broken wire #10A from resistor R1 to riser switch S25.
 - Check continuity. Replace if defective.
2. Defective riser switch S25.
 - Check continuity through switch while activating up function between wires #10A and #31. Replace switch if no continuity.
3. Loose or broken wire #31 from riser switch S25 to base terminal block.
 - Check continuity. Replace if defective.
4. Loose or broken wire #31 from base terminal block to main harness plug pin #8.
 - Check continuity. Replace if defective.
5. Loose or broken wire #31 from main harness plug pin #8 to riser up valve 5H-31.
 - Check continuity. Replace if defective.
6. Loose or broken wire #02 from main harness plug to riser up valve 5H-31.
 - Check continuity. Replace if defective.
7. Defective boom up coil 5H-31.
 - Check continuity and resistance through coil. Replace if defective.

4.1a-18 No Riser Down from Base Control Console

1. Loose or broken wire #10C from boom switch S12 to riser down switch S25.
 - Check continuity. Replace if defective.
2. Defective riser switch S25.
 - Check continuity through switch while activating down function between wires #10C and #30. If no continuity found, replace switch.
3. Loose or broken wire #30 from riser down switch S25 to base terminal block.
 - Check continuity. Replace if defective.
4. Loose or broken wire #30 from base terminal block to main harness plug pin #7.
 - Check continuity. Replace if defective.
5. Loose or broken wire #30 from main harness plug pin #7 to riser down valve 5H-30.
 - Check continuity. Replace if defective.
6. Loose or broken wire #02 from main harness plug to riser down valve 5H-30.
 - Check continuity. Replace if defective.
7. Defective riser down coil 5H-30.
 - Check continuity and resistance through coil. Replace if defective.

4.1a-19 No Turret Rotate Left from Base Control Console

1. Loose or broken wire #10C from resistor R1 to turret rotate switch S13.
 - Check continuity. Replace if defective.
2. Defective turret rotate switch S13.
 - Check continuity through switch while activating rotate left function between wires #10C and #32. If no continuity found, replace switch.
3. Loose or broken wire #32 from turret rotate switch S13 to base terminal block.
 - Check continuity. Replace if defective.
4. Loose or broken wire #32 from base terminal block to main harness plug pin #9.
 - Check continuity. Replace if defective.
5. Loose or broken wire #32 from main harness plug pin #9 to turret rotate left valve 5H-32.
 - Check continuity. Replace if defective.
6. Loose or broken wire #02 from main harness plug to turret rotate left valve 5H-32.
 - Check continuity. Replace if defective.
7. Defective turret rotate left valve coil 5H-32.
 - Check continuity and resistance through coil. Replace if defective.

CLICK HERE TO **DOWNLOAD** THE COMPLETE MANUAL

- Thank you very much for reading the preview of the manual.
- You can download the complete manual from: www.heydownloads.com by clicking the link below



- Please note: If there is no response to CLICKING the link, please download this PDF first and then click on it.

CLICK HERE TO **DOWNLOAD** THE COMPLETE MANUAL

4.1a-39 No Telescope In from Platform Control Console

1. Loose or broken wire #08 from platform terminal block to telescope switch S18.
 - Check continuity. Replace if defective.
2. Defective telescope switch S18.
 - Check continuity through switch while activating in function between wires #08 and #38.
3. Loose or broken wire #20A from telescope switch S18 to valve driver pin #33.
 - Check continuity. Replace if defective.
4. No output on pin #5 of the valve driver to wire #20B.
 - Check pin #5 for 12 volts. If no voltage present with foot on footswitch check section 5 for valve driver test procedure.
5. Loose or broken wire #38 from telescope switch S18 to plug B pin #8 in platform control console.
 - Check continuity. Replace if defective.
6. Loose or broken wire #38 in boom cable B or its connectors.
 - Check for continuity between pins #8 on cable B. Check for loose or corroded connections on cable connectors. Replace if wire is defective.
7. Loose or broken wire #38 from base connector plug B pin #8 to base terminal block.
 - Check continuity. Replace if defective.
8. Loose or broken wire #38 from base terminal block to main harness plug pin #13.
 - Check continuity. Replace if defective.
9. Loose or broken wire #38 from main harness plug pin #13 to telescope in valve 5H-38.
 - Check continuity. Replace if defective.
10. Loose or broken wire #02 from main harness plug to telescope in valve 5H-38.
 - Check continuity. Replace if defective.
11. Defective telescope in valve coil 5H-38.
 - Check continuity and resistance through coil. Replace if defective.

4.1a-40 No Telescope Out from Platform Control Console

1. Loose or broken wire #08 from platform terminal block to telescope switch S18.
 - Check continuity. Replace if defective.
2. Defective telescope switch S18.
 - Check continuity through switch while activating out function between wires #08 and #39.
3. Loose or broken wire #20A from telescope switch S18 to valve driver pin #33.
 - Check continuity. Replace if defective.
4. No output on pin #5 of the valve driver to wire #20B.
 - Check pin #5 for 12 volts. If no voltage present with foot on footswitch check section 5 for valve driver test procedure.
5. Loose or broken wire #39 from telescope switch S18 to plug B pin #9 in platform control console.
 - Check continuity. Replace if defective.
6. Loose or broken wire #39 in boom cable B or its connectors.
 - Check for continuity between pins #9 on cable B. Check for loose or corroded connections on cable connectors. Replace if wire is defective.
7. Loose or broken wire #39 from base connector plug B pin #9 to base terminal block.
 - Check continuity. Replace if defective.
8. Loose or broken wire #39 from base terminal block to main harness plug pin #14.
 - Check continuity. Replace if defective.
9. Loose or broken wire #39 from main harness plug pin #14 to telescope out valve 5H-39.
 - Check continuity. Replace if defective.
10. Loose or broken wire #02 from main harness plug to telescope out valve 5H-39.
 - Check continuity. Replace if defective.
11. Defective telescope out valve coil 5H-39.
 - Check continuity and resistance through coil. Replace if defective.

7. Loose or broken wire #02 from base terminal block to reverse drive valve 4H-15.
 - Check continuity. Replace if defective.
8. Defective reverse drive valve coil 4H-15.
 - Check continuity and resistance through coil. Replace if defective.

4.1a-55 No High Speed Drive

NOTE

Aerial platform must be level and boom must be fully retracted and horizontal or below.

1. Loose or broken wire #09 from base terminal block to limit switch LS2.
 - Check continuity. Replace if defective.
2. Open or defective limit switch LS2.
 - Ensure riser is fully stowed. Adjust switch if required. Check continuity through switch. Replace if required.
3. Loose or broken wire #29 from limit switch LS2 to base terminal block.
 - Check continuity. Replace if defective.
4. Loose or broken wire #29 from base terminal block to limit switch LS3.
 - Check continuity. Replace if defective.
5. Open or defective limit switch LS3.
 - Ensure boom is horizontal or below. Adjust switch if required. Check continuity through switch. Replace if defective.
6. Loose or broken wire #29A from limit switch LS3 to base terminal block.
 - Check continuity. Replace if defective.
7. Loose or broken wire #29A from base terminal block to limit switch LS4.
 - Check continuity. Replace if defective.
8. Open or defective limit switch LS4.
 - Ensure boom is fully retracted. Adjust switch if required. Check continuity through switch. Replace if defective.
9. Loose or broken wire #59 from limit switch LS4 to base terminal block.
 - Check continuity. Replace if defective.
10. Loose or broken wire #59 from base terminal block to plug B pin #15.
 - Check continuity. Replace if defective.
11. Loose or broken wire #59 in boom cable B or its connectors.
 - Check for continuity between pins #15 on cable B. Check for loose or corroded connections on cable connectors. Replace if wire is defective.
12. Loose or broken wire #59 from plug B pin #15 to platform terminal block.
 - Check continuity. Replace if defective.
13. Loose or broken wire #59 from platform terminal block to valve driver pin #31.
 - Check continuity. Replace if defective.
14. Defective valve driver channel input for high drive enable.
 - See section 5 for test procedure on valve driver.
15. Loose or broken wire #59 from platform terminal block to torque switch S48.
 - Check continuity. Replace if defective.
16. Open or defective torque switch S48.
 - Check continuity through switch while activating low torque function between wires #59 and #45. If no continuity found replace switch.
17. Loose or broken wire #45 from torque switch S48 to plug A pin #20 in platform control console.
 - Check continuity. Replace if defective.

16. Loose or broken wire #02 from dump valve 2H-21A to main harness plug.
 - Check continuity. Replace if defective.
17. Defective dump valve coil 2H-21A.
 - Check continuity and resistance through coil. Replace if defective.

4.1b-12 No Main Boom Down, Riser Down or Turret Rotate from Base Control Console

1. Loose or broken wire #10A from base terminal block to resistor R1.
 - Check continuity. Replace if defective.
2. Open resistor R1.
 - Check resistor for 6 ohms. If no resistance found, replace resistor.
3. Loose or broken wire #10C from resistor R1 to turret rotate switch S13, boom down switch S12 and riser down switch S25.
 - Check continuity. Replace if defective.

4.1b-13 No Boom Up from Base Control Console

1. Loose or broken wire #10A from level switch S15 to boom switch S12.
 - Check continuity. Replace if defective.
2. Defective boom switch S12.
 - Check continuity through switch while activating up function between wires #10A and #14. Replace switch if no continuity.
3. Loose or broken wire #14 from boom switch S12 to base terminal block.
 - Check continuity. Replace if defective.
4. Loose or broken wire #14 from base terminal block to main harness plug pin #2.
 - Check continuity. Replace if defective.
5. Loose or broken wire #14 from main harness plug pin #2 to boom up valve 5H-14.
 - Check continuity. Replace if defective.
6. Loose or broken wire #02 from main harness plug to boom up valve 5H-14.
 - Check continuity. Replace if defective.
7. Defective boom up coil 5H-14.
 - Check continuity and resistance through coil. Replace if defective.

4.1b-14 No Boom Down from Base Control Console

1. Loose or broken wire #10C from resistor R1 to boom down switch S12.
 - Check continuity. Replace if defective.
2. Defective boom switch S12.
 - Check continuity through switch while activating down function between wires #10C and #13. If no continuity found, replace switch.
3. Loose or broken wire #13 from boom down switch S12 to base terminal block.
 - Check continuity. Replace if defective.
4. Loose or broken wire #13 from base terminal block to main harness plug pin #1.
 - Check continuity. Replace if defective.
5. Loose or broken wire #13 from main harness plug pin #1 to boom down valve 5H-13.
 - Check continuity. Replace if defective.
6. Loose or broken wire #02 from main harness plug to boom down valve 5H-13.
 - Check continuity. Replace if defective.
7. Defective boom down coil 5H-13.
 - Check continuity and resistance through coil. Replace if defective.

9. Loose or broken wire #32 from base connector plug A pin #14 to base terminal block.
 - Check continuity. Replace if defective.
10. Loose or broken wire #32 from base terminal block to main harness plug pin #9.
 - Check continuity. Replace if defective.
11. Loose or broken wire #32 from main harness plug pin #9 to turret left valve 5H-32.
 - Check continuity. Replace if defective.
12. Loose or broken wire #02 from main harness plug to turret left valve 5H-32.
 - Check continuity. Replace if defective.
13. Defective turret left valve coil 5H-32.
 - Check continuity and resistance through coil. Replace if defective.

4.1b-35 No Turret Right from Platform Control Console

1. Loose or broken wire #04 from platform terminal block to joystick controller A1.
 - Check continuity. Replace if defective.
2. Loose or broken wire #02 from platform terminal block to joystick controller A1.
 - Check continuity. Replace if defective.
3. No output on x-axis of joystick controller A1.
 - Refer to joystick test procedure in section 5.
4. Loose or broken wire "X" from joystick controller A1 to valve driver pin #28.
 - Check continuity. Replace if defective.
5. No output on pin #5 of the valve driver to wire #20B.
 - Check pin #5 for 12 volts. If no voltage present with foot on footswitch check section 5 for valve driver test procedure.
6. No output on pin #35 of the valve driver to wire #33.
 - Check pin #35 for minimum 3.5 volts. If no voltage present with foot on footswitch check section 5 for valve driver test procedure.
7. Loose or broken wire #33 from valve driver pin #35 to plug A pin #15 in platform control console.
 - Check continuity. Replace if defective.
8. Loose or broken wire #33 in boom cable A or its connectors.
 - Check for continuity between pins #15 on cable A. Check for loose or corroded connections on cable connectors. Replace if wire is defective.
9. Loose or broken wire #33 from base connector plug A pin #15 to base terminal block.
 - Check continuity. Replace if defective.
10. Loose or broken wire #33 from base terminal block to main harness plug pin #10.
 - Check continuity. Replace if defective.
11. Loose or broken wire #33 from main harness plug pin #10 to turret right valve 5H-33.
 - Check continuity. Replace if defective.
12. Loose or broken wire #02 from main harness plug to turret right valve 5H-33.
 - Check continuity. Replace if defective.
13. Defective turret right valve coil 5H-33.
 - Check continuity and resistance through coil. Replace if defective.

4.1b-36 No Toggle Switch Functions from Platform Control Console

1. Loose or broken wire #08 or #04 from platform terminal block to toggle switches.
 - Check continuity. Replace if defective.
2. Loose or broken wire #20A from toggle switches to valve driver pin #33.
 - Check continuity. Replace if defective.
3. No output on pin #5 of the valve driver to wire #20B.
 - Check pin #5 for 12 volts. If no voltage present with foot on footswitch check section 5 for valve driver test procedure.

4.1b-51 No Forward Drive

1. No output on "D" when forward is selected on drive joystick A2.
 - See drive joystick test procedure in section 5.
2. Loose or broken wire "D-signal" from drive joystick A2 to valve driver pin #27.
 - Check continuity. Replace if defective.
3. No output from valve driver pin #34 to wire #16.
 - Check pin #34 for minimum 2 volts. If no voltage present with foot on footswitch check section 5 for valve driver test procedure.
4. Loose or broken wire #16 from valve driver pin #34 to plug B pin #5 in platform control console.
 - Check continuity. Replace if defective.
5. Loose or broken wire #16 in cable B or its connectors.
 - Check for continuity between pins #5 on cable B. Check for loose or corroded connections on cable connectors. Replace if wire is defective.
6. Loose or broken wire #16 from base plug B pin #5 to forward drive valve 4H-16.
 - Check continuity. Replace if defective.
7. Loose or broken wire #02 from base terminal block to forward drive valve 4H-16.
 - Check continuity. Replace if defective.
8. Defective forward drive valve coil 4H-16.
 - Check continuity and resistance through coil. Replace if defective.

4.1b-52 No Reverse Drive

1. No output on "D" when reverse is selected on drive joystick A2.
 - See drive joystick test procedure in section 5.
2. Loose or broken wire "D-signal" from drive joystick A2 to valve driver pin #27.
 - Check continuity. Replace if defective.
3. No output from valve driver pin #23 to wire #15.
 - Check pin #23 for minimum 2 volts. If no voltage present with foot on footswitch check section 5 for valve driver test procedure.
4. Loose or broken wire #15 from valve driver pin #23 to plug B pin #4 in platform control console.
 - Check continuity. Replace if defective.
5. Loose or broken wire #15 in cable B or its connectors.
 - Check for continuity between pins #4 on cable B. Check for loose or corroded connections on cable connectors. Replace if wire is defective.
6. Loose or broken wire #15 from base plug B pin #4 to reverse drive valve 4H-15.
 - Check continuity. Replace if defective.
7. Loose or broken wire #02 from base terminal block to reverse drive valve 4H-15.
 - Check continuity. Replace if defective.
8. Defective reverse drive valve coil 4H-15.
 - Check continuity and resistance through coil. Replace if defective.

4.1b-53 No High Speed Drive**NOTE**

Aerial platform must be level and boom must be fully retracted and horizontal or below.

1. Loose or broken wire #09 from base terminal block to limit switch LS2.
 - Check continuity. Replace if defective.
2. Open or defective limit switch LS2.
 - Ensure riser is fully stowed. Adjust switch if required. Check continuity through switch. Replace if required.

8. Worn or defective drive motor M1.
 - Check motor. Replace if defective.

4.2a-23 No Forward Drive

1. Defective pump displacement control 4H-16.
 - Check control. Replace if defective.
2. Defective or misadjusted drive relief valve RV9.
 - See section 5 for drive pump set up procedures.
3. Drive servo stuck in neutral position.
 - Check valve. Replace if defective.

4.2a-24 No Reverse Drive

1. Defective pump displacement control 4H-15.
 - Check control. Replace if defective.
2. Defective or misadjusted drive relief valve RV8.
 - See section 5 for drive pump set up procedures.
3. Drive servo stuck in neutral position.
 - Check valve. Replace if defective.

4.2a-25 No High Speed Drive

1. Stuck or defective 2 speed valve 3H-45.
 - Clean valve. Check O-rings on valve. Check operation of valve. Repair or replace valve as required.
2. Defective shift valve V5 in drive motor M1.
 - Check motor. Repair or replace if necessary.

4.2a-26 No Right Steer

1. Stuck or defective right steer valve 5H-23A.
 - Clean valve. Check operation of valve. Repair or replace valve as required.
2. Stuck or defective check valve CV2.
 - Clean valve. Check O-rings on valve. Check operation of valve. Repair or replace valve as required.
3. Stuck or defective dual pilot check valve DPOCV1.
 - Clean valve. Check O-rings on valve. Check operation of valve. Repair or replace valve as required.
4. Defective steer cylinder C8.
 - Check seals on cylinder. Replace as necessary. Replace cylinder if defective.

4.2a-27 No Left Steer

1. Stuck or defective left steer valve 5H-24A.
 - Clean valve. Check operation of valve. Repair or replace valve as required.
2. Stuck or defective check valve CV2.
 - Clean valve. Check O-rings on valve. Check operation of valve. Repair or replace valve as required.
3. Stuck or defective dual pilot check valve DPOCV1.
 - Clean valve. Check O-rings on valve. Check operation of valve. Repair or replace valve as required.
4. Defective steer cylinder C8.
 - Check seals on cylinder. Replace as necessary. Replace cylinder if defective.

4.3 Load Sensing System (CE)

4.3-1 Green Power LED is not Flashing

1. Loose or broken wires #60 and #02 at platform terminal block.
 - Check for connections. Check for voltage (12V).
2. Load cell has lost its calibration.
 - Refer to calibration procedure for recalibration of load cell.

4.3-2 Load Cell red Alarm LED is ON (with platform empty)

1. Load cell has lost its calibration.
 - Refer to calibration procedure for recalibration of load cell.

4.3-3 Red Error LED is ON

1. Open safety contact circuit.
 - Check for connections with wires #161 and #162A at platform terminal block and base terminal block. Check resistor R6 for 680 ohms.

4.3-4 Load Cell red Alarm LED is OFF (with platform overloaded)

1. Open safety contact circuit.
 - Check for connections with wires #161 and #162 at platform terminal block and base terminal block. Check resistor R6 for 680 ohms.

4.3-5 Platform Indicator Light does not turn ON

1. Defective lamp.
 - Check lamp. Replace if defective.
2. Defective relay 82CR.
 - Check relay. Replace if defective.
3. Load cell circuit not operating.
 - Check for connections with wire #02B at pilot light strip and relay 82CR, and wire #82 at platform terminal block and relay 82CR.
4. Defective load cell.
 - Defective if 0V is measured between wire #82 and #02 from platform terminal block.

4.3-6 Audible Alarm does not turn ON

1. Defective alarm BP3.
 - Check alarm. Replace if defective.
2. Open or defective diode D118.
 - Check diode. Replace if defective.
3. Load cell circuit not operating.
 - Check for connections with wires #02 and #118 at platform terminal block.
4. Defective load cell.
 - Defective if 0V is measured between wire #118 and #02 from platform terminal block.

4.3-7 Boom and Drive Functions are Enabled (with boom extended)

1. "Fly IN" limit switch LS3 is not operating properly.
 - Check for voltage (0V) between wires #59 and #02 from platform terminal block. If 12V is measured, check for proper actuation of limit switch. Readjust limit switch if necessary.
2. Defective load cell. Safety contact remains closed.
 - Check for voltage (0V) between wires #162 and #02 from base terminal block. Defective if 12V is measured.

5.1-6 OCM Pin Voltage Reference

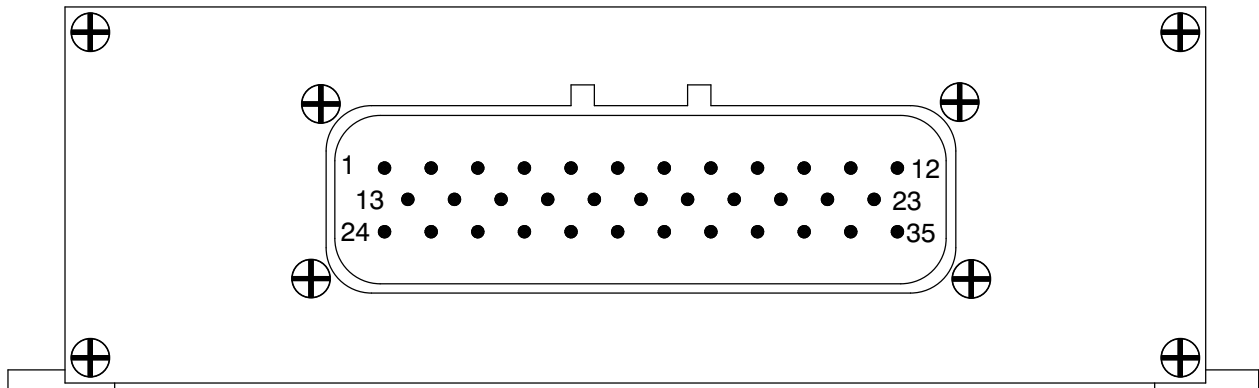

All voltages given are with OCM controller at maximum % adjustable settings.
 All voltages should be tested with key on, engine off and foot switch depressed.
 All tests should be performed with platform over drive axle, boom fully stowed and on flat level surface.

- Pin 1 - 12 volt input from wire 4.
Test between pin 1 and 02 wire.
- Pin 2 - 12 volt input from wire 4.
Test between pin 2 and 02 wire.
- Pin 3 - Not used.
- Pin 4 - 12 Volt output on wire 24A to left steer valve 5H-24A
Test between pin 4 and 02 wire.
- Pin 5 - 12 volt output on wire 20B to dump valve relay 21CR.
Test between pin 5 and 02 wire while selecting a function.
- Pin 6 - 12 volt output on wire 08 to toggle switch boom functions. (Foot switch activated)
Test between pin 6 and 02 wire.
- Pin 7 - 12 volt output on wire 65 to axle lock valve 3H-65.
Test between pin 7 and 02 wire.
- Pin 8 - Boom down selected. Proportional output on wire 13 to boom down valve 5H-13.
0 volts to 5.5 volts depending on position of joystick. Threshold= 1.0 volt.
Test between pin 8 and 02 wire while operating boom down.
- Pin 9 - Riser up selected. Proportional output on wire 31 to riser up valve 5H-31.
0 volts to 7.5 volts depending on position of joystick. Threshold= 2.8 volts.
Test between pin 9 and 02 wire while operating boom down.
- Pin 10 - 12 volt output on wire 26 brake valve 3H-26. 12V=Drive selected
Test between pin 10 and 02 wire.
- Pin 11 - 12 volt output on wire 27 to tilt alarm relay 27CR.
Test between pin 11 and 02 wire

4. Support the boom with an overhang crane. Do not lift the boom.
5. Turn main power disconnect switch to "O" off position.
6. Loosen mounting fasteners on the swing drive motor.
7. Push the swing drive motor towards the center of turret as close as possible. (this will push the rotation gear into the rotation bearing)
8. Loosen lock nut on adjustment bolt.
9. Tighten adjustment bolt clockwise until it contacts the plate of gearbox.
10. Turn adjustment bolt 1/2 turn counterclockwise, then tighten lock nut on adjustment bolt.
11. Pull the swing drive motor away from turret until it contacts the adjustment bolt.
12. Tighten mounting fasteners on swing drive motor.
13. Unlock the turret lock pin.
14. Turn main power disconnect switch to "I" ON position.
15. Rotate turret through an entire rotation and check for a smooth rotation of the turret.
16. Adjust adjustment bolt until smooth rotation of the turret is achieved.
17. Unsecure riser boom and lower boom.

5.3-4 Swing Drive Motor Removal

The swing drive motor is located near the center of the turret, underneath the riser/main boom.



WARNING

Ensure that there are no personnel or obstructions in test area and there is sufficient room for boom to swing and elevate.

1. Ensure aerial platform is on a firm level surface.



WARNING

Operator must lock the turret to base to prevent the turret from spinning spontaneously.

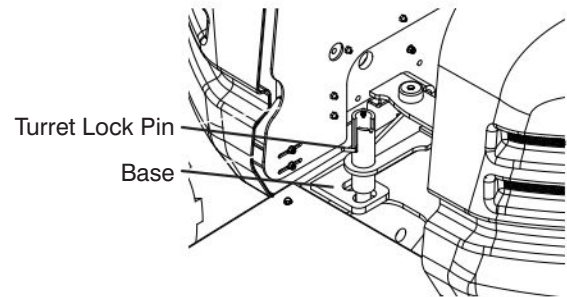

Turret Lock Pin

2. Lock the turret to base with the turret lock pin.
3. Raise riser boom to access the swing drive motor.
4. Support the boom with an overhang crane. Do not lift the boom.
5. Turn main power disconnect switch to "O" off position.
6. Label the hydraulic hoses connected to swing drive and then remove hoses from motor. Plug hoses and fittings to prevent hydraulic contamination.
7. Loosen adjustment bolt and remove mounting fasteners from the swing drive motor.
8. use a lift device to remove swing drive motor out away from turret and place it aside.

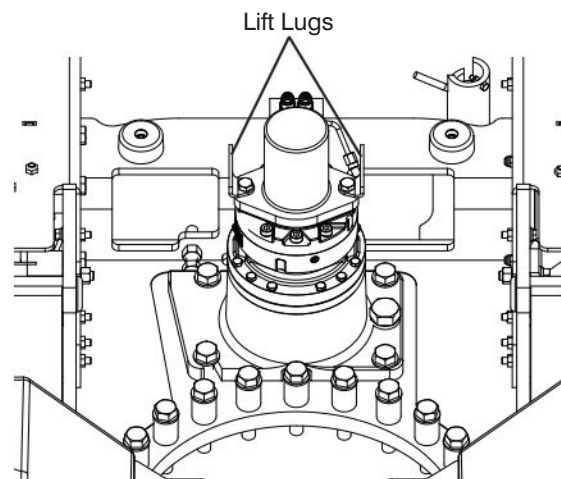

Swing Drive Lift Lugs

5.3-5 Swing Drive Motor Replacement

5.4-6 Deutz TD2.9L Fault Codes

Code	SPN	FMI	Blink Code	Error Identification
122	523698	11	5-9-1	Shut off request from supervisory monitoring function.
124	523969	11	7-7-4	Fault entry for override control mode.
125	523717	12	5-9-5	Timeout error of CAN-transmit-frame AmbCon; Weather environments.
126	523603	9	3-3-8	Timeout Error of CAN-receive-frame AMB; Ambient temperature sensor.
128	3224	9	5-9-7	Timeout error of CAN-receive-frame AT1IG1; NOX sensor upstream.
129	3224	2	5-9-6	DLC error of CAN-receive-frame AT1IG1Vol NOX sensor.
130	3224	9	5-9-7	Timeout error of CAN-receive-frame AT1IG1Vol; NOX sensor.
133	523938	9	7-6-6	Timeout error (BAM to packet) for CAN-receive-frame AT1IGCVol1.
134	523939	9	7-6-6	Broadcast announce message of the calibration message of the upstream catalytic NOx sensor has failed.
135	523940	9	7-6-6	Timeout error (PCK2PCK) for CAN-Receive-Frame AT1IGCVol1.
136	3234	2	1-1-4	DLC error of CAN-Receive-Frame AT1O1.
137	3234	9	1-1-7	Timeout error of CAN-Receive-Frame AT1OG1. NOX sensor (SCR-system downstream cat; DPF-system downstream cat).
138	3234	2	1-1-4	DLC error of CAN-Receive-Frame AT1O1Vol.
139	3234	9	1-1-7	Timeout error of CAN-Receive-Frame AT1OG1Vol.
140	523941	9	7-6-7	Timeout error (BAM to packet) for CAN-Receive-Frame AT1OGCVol2.
141	523942	9	7-6-7	Calibration message 1 of the after catalyst Nox sensor has failed.
142	523943	9	7-6-7	Timeout error (PCK2PCK) for CAN-Receive-Frame AT1OGCVol2.
153	523992	9	7-9-3	Not used.
155	0	0	-	Not used.
164	523211	9	3-3-1	Timeout error of CAN-Receive-Frame EBC1.
167	523704	12	6-1-5	Timeout error of CAN-Transmit-Frame EEC3.
168	523935	12	7-6-3	Timeout error of CAN-Transmit-Frame EEC3VOL1. Engine send messages.
169	523936	12	7-6-4	Timeout error of CAN-Transmit-Frame EEC3VOL2. Engine send messages.
171	523212	9	3-3-3	Timeout error of CAN-Receive-Frame ComEngPrt. Engine Protection.
172	523741	14	6-1-8	Engine shut off request through CAN.
174	523213	12	3-3-4	Timeout error of CAN-Transmit-Frame ERC1.
178	523706	12	6-2-3	Timeout error of CAN-Transmit-Frame FIEco.
179	523240	9	5-2-7	Timeout CAN-message FunModCtl. Function Mode Control.
193	523937	9	7-6-5	Timeout DFC for NOxSensGlbReqTx.
196	3227	2	6-3-8	DFC SAE J1939 error.
198	523216	9	3-3-7	Timeout error of CAN-Receive-Frame PrHtEnCmd. Pre-heat command, engine command.
202	523793	9	6-7-8	Timeout error of CAN-Receive-Frame UAA10. AGS sensor service message.
203	523794	9	6-7-8	Timeout error of CAN-Receive-Frame UAA11. AGS sensor data.
212	523803	9	6-7-8	Timeout error of CAN-Receive-Message RxEngPres. Status Burner Air Pump.

1513AA-3

5.4-6 Deutz TD2.9L Fault Codes

Code	SPN	FMI	Blink Code	Error Identification
970	624	12	5-1-3	SVS lamp: powerstage over temperature
971	624	3	5-1-3	SVS lamp; short circuit to battery
972	624	4	5-1-3	SVS lamp; short circuit to ground
973	523612	14	5-5-5	Softwarereset CPU SWReset_0
974	523612	14	5-5-5	Softwarereset CPU SWReset_1
975	523612	14	5-5-5	Softwarereset CPU SWReset_2
976	91	11	2-2-6	Plausibility error between APP1 and APP2 or APP1 and idle switch.
978	29	2	1-2-6	Plausibility error between sensor and idle switch, Acceleratio Pedal Detection. In case of Hand Throttle with Low Idle Switch, it is the plausibility check between hand throttle and idle switch.
980	523550	12	5-1-5	Terminal 50 was operated too long.
981	172	3	2-2-6	Air flow temperature sensor; short circuit to battery or open load.
982	172	4	2-2-6	Air flow temperature sensor; short circuit to ground.
986	523921	0	7-1-4	Burner temperature, temperature above upper shutoff threshold.
989	523921	1	7-1-4	Burner temperature, temperature below lower shutoff threshold.
992	105	1	1-2-8	Charged Air cooler down stream temperature. Temperature below lower physical threshold.
994	105	3	1-2-8	Electrical error charged air temperature. Signal range check high.(SRC)
995	105	4	1-2-8	Electrical error charged air temperature. Signal range check low.
996	105	0	2-3-3	Charged air cooler temperature. System reaction initiated. High charged air cooler temperature. Warning threshold exceeded.
997	105	0	2-3-3	High charged air cooler temperature. Shut off threshold exceeded.
998	105	11	1-2-8	Diagnostic fault check for charged air cooler downstream temperature sensor No detailed information!
1007	412	3	6-8-2	Electrical error EGR cooler downstream temperature. Signal range check high.
1008	412	4	6-8-2	electrical error EGR cooler downstream temperature. Signal range check low.
1011	523960	0	7-7-1	Physical range check high for EGR cooler downstream temperature.
1012	523960	1	7-7-1	Physical range check low for EGR cooler downstream temperature.
1014	51	6	5-9-4	Actuator error EGR-Valve (2.9;3.6) or Throttle-Valve (4.1;6.1;7.8). Signal range check high.
1015	520521	5	5-9-4	Actuator error EGR-Valve (2.9;3.6) or Throttle-Valve (4.1;6.1;7.8); signal range check low.
1016	51	7	5-9-4	Actuator position for EGR-Valve (2.9;3.6) or Throttle-Valve (4.1;6.1;7.8) not plausible.
1022	51	6	5-9-4	Actuator error EGR-Valve (2.9;3.6) or Throttle-Valve (4.1;6.1;7.8); signal range check high

1513AA-13

5.5-3 Throttle Actuator (3.0L GM Engine)

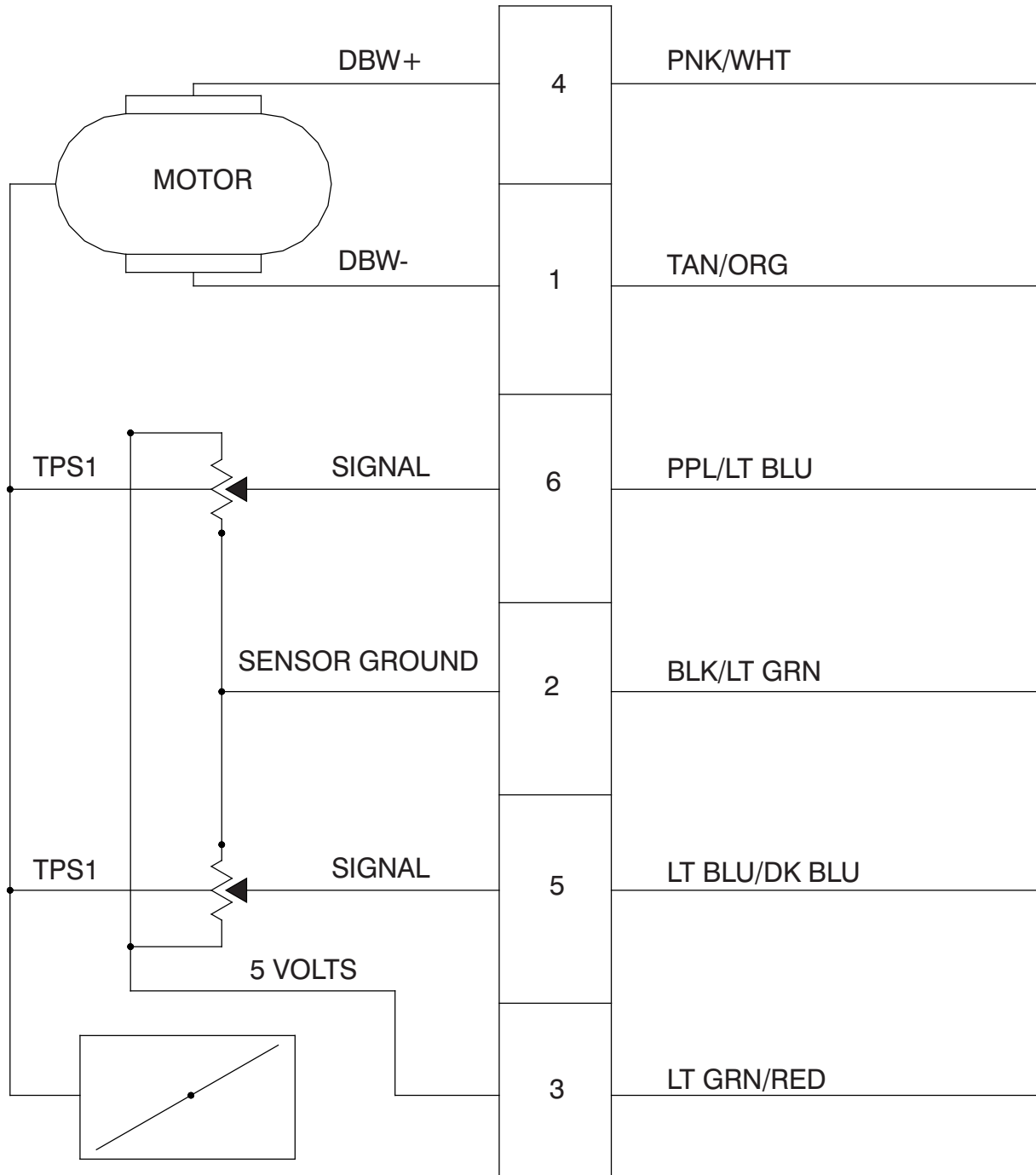

5.7-10 Test Reverse Drive Pressure on Drive Pump

NOTE

Make sure charge pump pressure test is completed first.

1. Locate test port TP2 on the drive pump.
2. Connect a pressure gauge (10000 psi) to test port TP2.

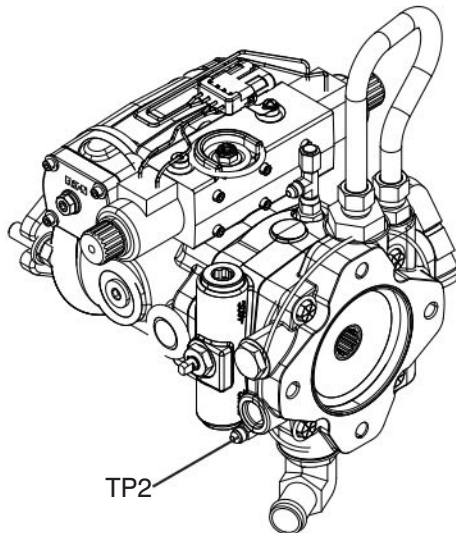

Drive Pump - Reverse Drive Pressure

3. Start engine from platform control console.
4. Unplug brake solenoid power cable (26) on brake valve.
5. Activate drive function slowly reverse with engine at high speed. Wheels should not turn.

NOTE

Activating drive function too fast will stall the engine.

6. Check reading on gauges Standard pressure should be 5000 psi. Go to step 8 if pump pressure is achieved.
7. Replace pump if pressure is not achieved.
8. Turn engine off.
9. Remove pressure gauge from port, cap the port and re-plug brake solenoid power cable.

5.7-11 Hydraulic Standby Pressure Adjustment

1. Locate GP Port on main manifold.

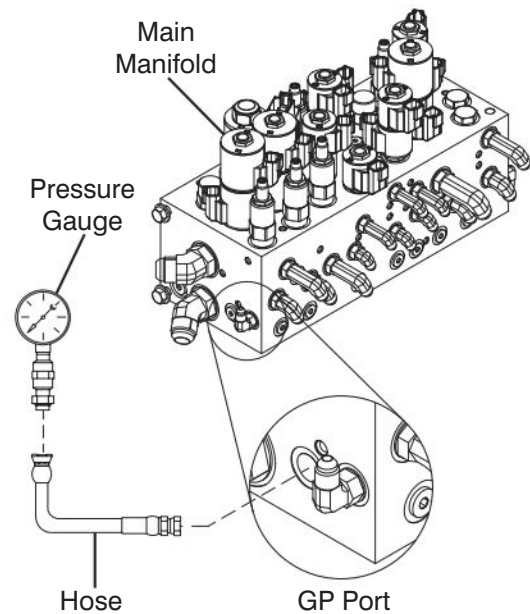

Main Manifold and Pressure Gauge

2. Connect a pressure gauge (600 psi) to GP port.
3. Start engine from base control console and let it run for 2-5 minutes.
4. Check reading on gauge (standard pressure should be 270 psi) and follow the next steps for adjusting pressure if needed.

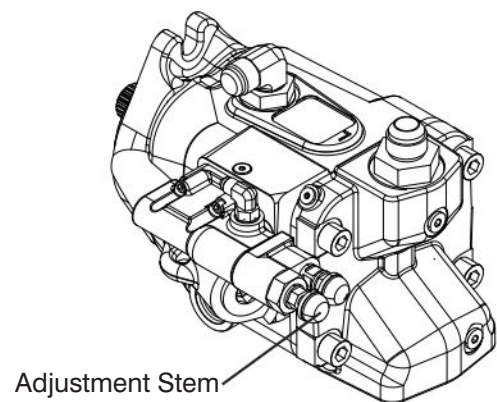

System Pump

CLICK HERE TO **DOWNLOAD** THE COMPLETE MANUAL

- Thank you very much for reading the preview of the manual.
- You can download the complete manual from: www.heydownloads.com by clicking the link below



- Please note: If there is no response to CLICKING the link, please download this PDF first and then click on it.

CLICK HERE TO **DOWNLOAD** THE COMPLETE MANUAL