



SERVICE MANUAL

TELESCOPIC BOOMS

MODELS **SJ40T** **SJ45T**

166874AF November 2018

SKYJACK

CLICK HERE TO **DOWNLOAD** THE COMPLETE MANUAL





- Thank you very much for reading the preview of the manual.
- You can download the complete manual from: www.heydownloads.com by clicking the link below



- Please note: If there is no response to CLICKING the link, please download this PDF first and then click on it.



CLICK HERE TO **DOWNLOAD** THE COMPLETE MANUAL

Table 1.1 Owner's Annual Inspection Record

										
 Model Number: _____ Serial Number: _____										
*		20__	20__	20__	20__	20__	20__	20__	20__	20__
**										

1001AB

This decal is located on the control compartment cowling. It must be completed after an annual inspection has been completed. Do not use the aerial platform if an inspection has not been recorded in the last 6 months.

	Pictorial	Description
*		Inspection Date
**		Inspector Signature

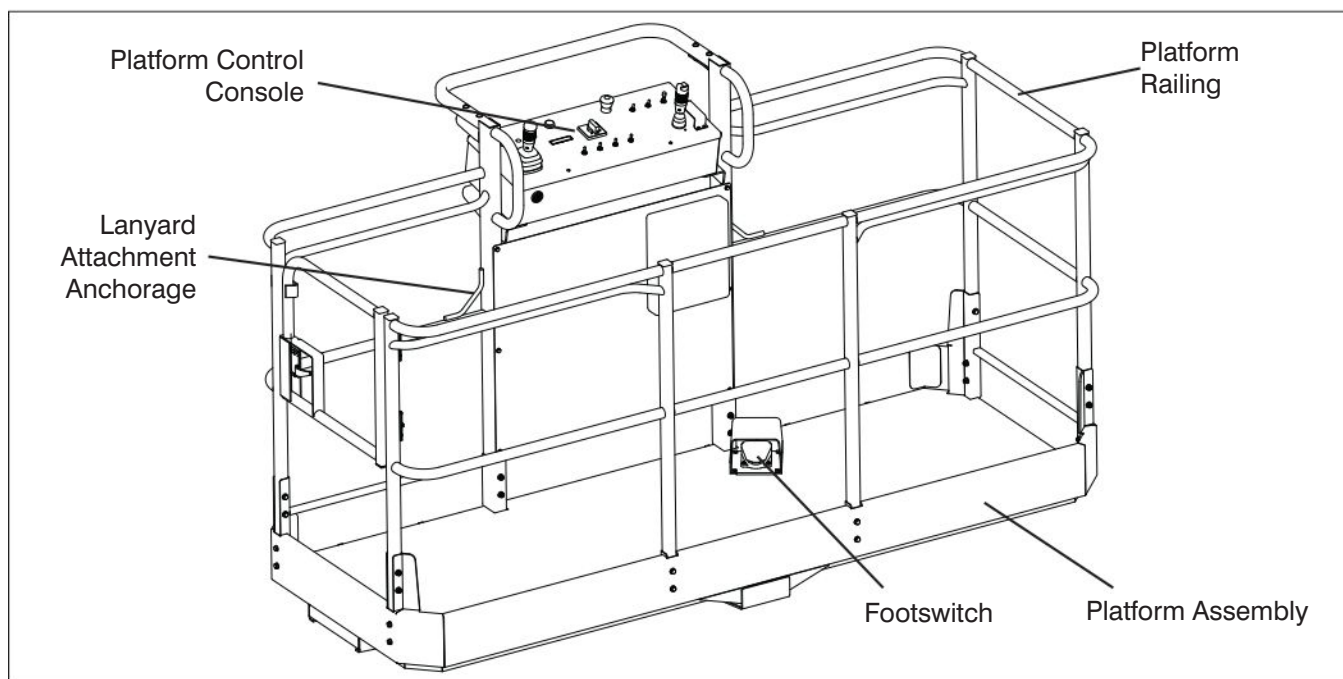
**1.1-7 Platform Assembly (B)**

- Ensure there are no loose or missing parts and there is no visible damage.
- Ensure all fasteners are securely in place.
- Ensure all railings are properly positioned and secured.
- Ensure gate/drop-bar(s) are in good working order.
- Ensure footswitch is in good working order and has not been modified, disabled or blocked.
- Ensure lanyard attachment anchorages are secure and there is no visible damage.

1.1-8 Platform Control Console (B)

- Ensure all switches/controllers are returned to neutral and are properly secured.
- Ensure there are no loose or missing parts and there is no visible damage.

Table 2.5 Torque Specifications for Fasteners (Metric)

METRIC BOLT TORQUE CHART					
Size	Torque Units	8.8		10.9	
		Dry	Lubed	Dry	Lubed
M5 x 0.80	(in-lb)	(54)	(41)	(78)	(59)
	Nm	6.1	4.6	8.8	6.7
M6 x 1.00	(in-lb)	(92)	(69)	(133)	(99)
	Nm	10.4	7.8	15	11.2
M7 x 1.00	(in-lb)	(156)	(116)	(222)	(167)
	Nm	17.6	13.1	25.1	18.9
M8 x 1.25	(in-lb)	(225)	(169)	(333)	(242)
	Nm	25.4	19.1	37.6	27.3
M10 x 1.50	ft-lb	37	28	53	40
	Nm	50	38	72	54
M12 x 1.75	ft-lb	65	49	93	69
	Nm	88	66	126	94
M14 x 2.00	ft-lb	104	78	148	111
	Nm	141	106	201	150
M16 x 2.00	ft-lb	161	121	230	172
	Nm	218	164	312	233
M18 x 2.50	ft-lb	222	167	318	238
	Nm	301	226	431	323
M20 x 2.50	ft-lb	314	235	449	337
	Nm	426	319	609	457
M22 x 2.50	ft-lb	428	321	613	460
	Nm	580	435	831	624
M24 x 3.00	ft-lb	543	407	776	582
	Nm	736	552	1052	789
M27 x 3.00	ft-lb	796	597	1139	854
	Nm	1079	809	1544	1158
M30 x 3.50	ft-lb	1079	809	1543	1158
	Nm	1463	1097	2092	1570
M33 x 3.50	ft-lb	1468	1101	2101	1576
	Nm	1990	1493	2849	2137
M36 x 4.00	ft-lb	1886	1415	2699	2024
	Nm	2557	1918	3659	2744
Inch-Pound Force = in-lb Foot-Pound Force = ft-lb Newton-Meter = Nm					

NOTE: Lubed includes lubricants such as lubricating oil, grease or uncured Loctite.



Diagram 2.3 Axle Oscillation Diagrams



WARNING

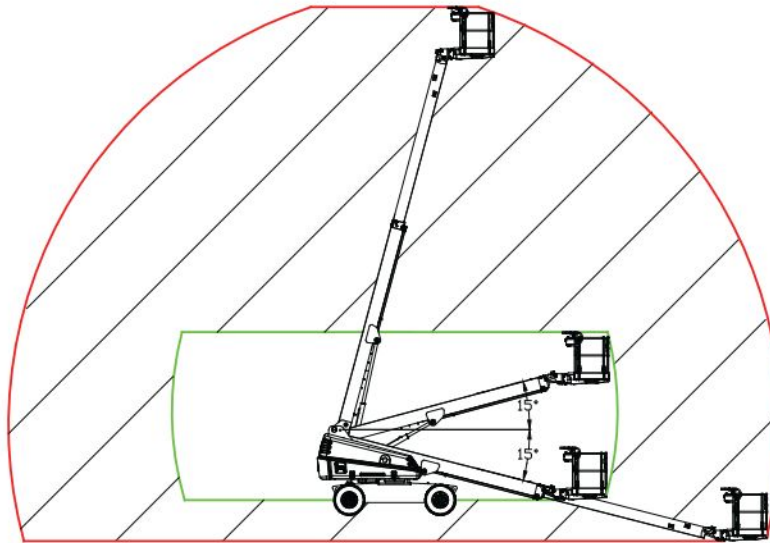

Do not raise the platform in work mode if it is not on a firm level surface.

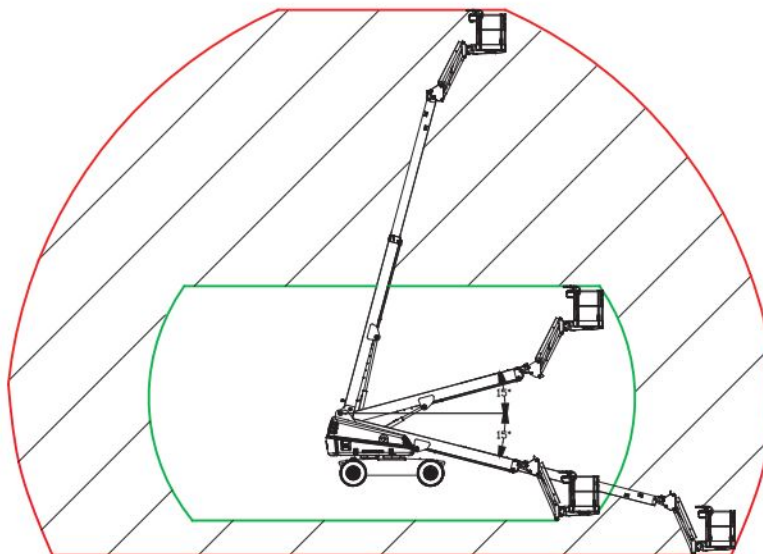

-  Axle oscillation free (travel mode) - drive speed 4.5 mph max.
-  Axle oscillation locked (work mode) - drive speed 0.5 mph max.

Axle Oscillation - No Jib Boom



-  Axle oscillation free (travel mode) - drive speed 4.5 mph max.
-  Axle oscillation locked (work mode) - drive speed 0.5 mph max.

Axle Oscillation - Jib Boom

3.5 Electrical Component Parts List

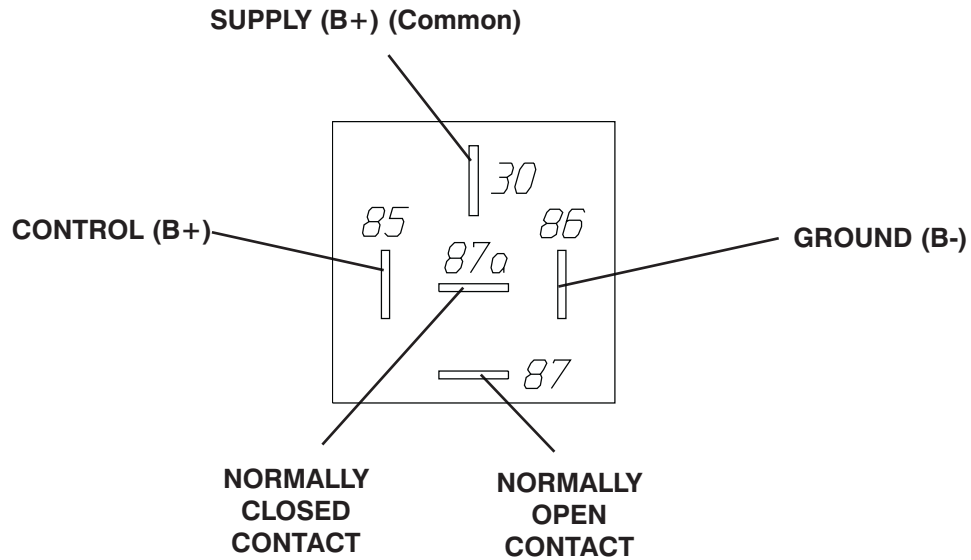

Index No.	Skyjack Part No.	Qty.	Description
01CR	127131	1	RELAY, 12 Volt 40 Amp (E-pump)
08BCR	127131	1	RELAY, 12 Volt 40 Amp (Enable)
08CR	127131	1	RELAY, 12 Volt 40 Amp (Engine start interlock)
08CR1	127131	1	RELAY, 12 Volt 40 Amp (Dump valve enable)
09CR	127131	1	RELAY, 12 Volt 40 Amp (Engine power on)
17ACR1	127131	1	RELAY, 12 Volt 40 Amp (Steering reversal)
17ACR2	127131	1	RELAY, 12 Volt 40 Amp (Steering reversal)
21CR	127131	1	RELAY, 12 Volt 40 Amp (Dump valve)
27CR	127131	1	RELAY, 12 Volt 40 Amp (Tilt alarm)
45CR1	127131	1	RELAY, 12 Volt 40 Amp (Drive speed)
45CR2	127131	1	RELAY, 12 Volt 40 Amp (Drive speed)
49CR	127131	1	RELAY, 12 Volt 40 Amp (Horn)
51CR	127131	1	RELAY, 12 Volt 40 Amp (Drive enable)
51CR1	127131	1	RELAY, 12 Volt 40 Amp (Tilt alarm)
54ACR	138844	1	RELAY, 12 Volt 80 Amp (Cold starter)
57ACR	127131	1	RELAY, 12 Volt 40 Amp (Anti restart)
57BCR	127131	1	RELAY, 12 Volt 40 Amp (Anti restart)
57BCR1	127131	1	RELAY, 12 Volt 40 Amp (Engine start)
59CR	127131	1	RELAY, 12 Volt 40 Amp (Optional axle lock)
60CR	127131	1	RELAY, 12 Volt 40 Amp (System power)
78CR	127131	1	RELAY, 12 Volt 40 Amp (High idle)
79CR	127131	1	RELAY, 12 Volt 40 Amp (Low idle)
81CR	127131	1	RELAY, 12 Volt 40 Amp (Optional light)
82CR	127131	1	RELAY, 12 Volt 40 Amp (Overload alarm) (CE & AS)

Parts list continued on following page.

3.12 No Jib Valve and Port Identifications

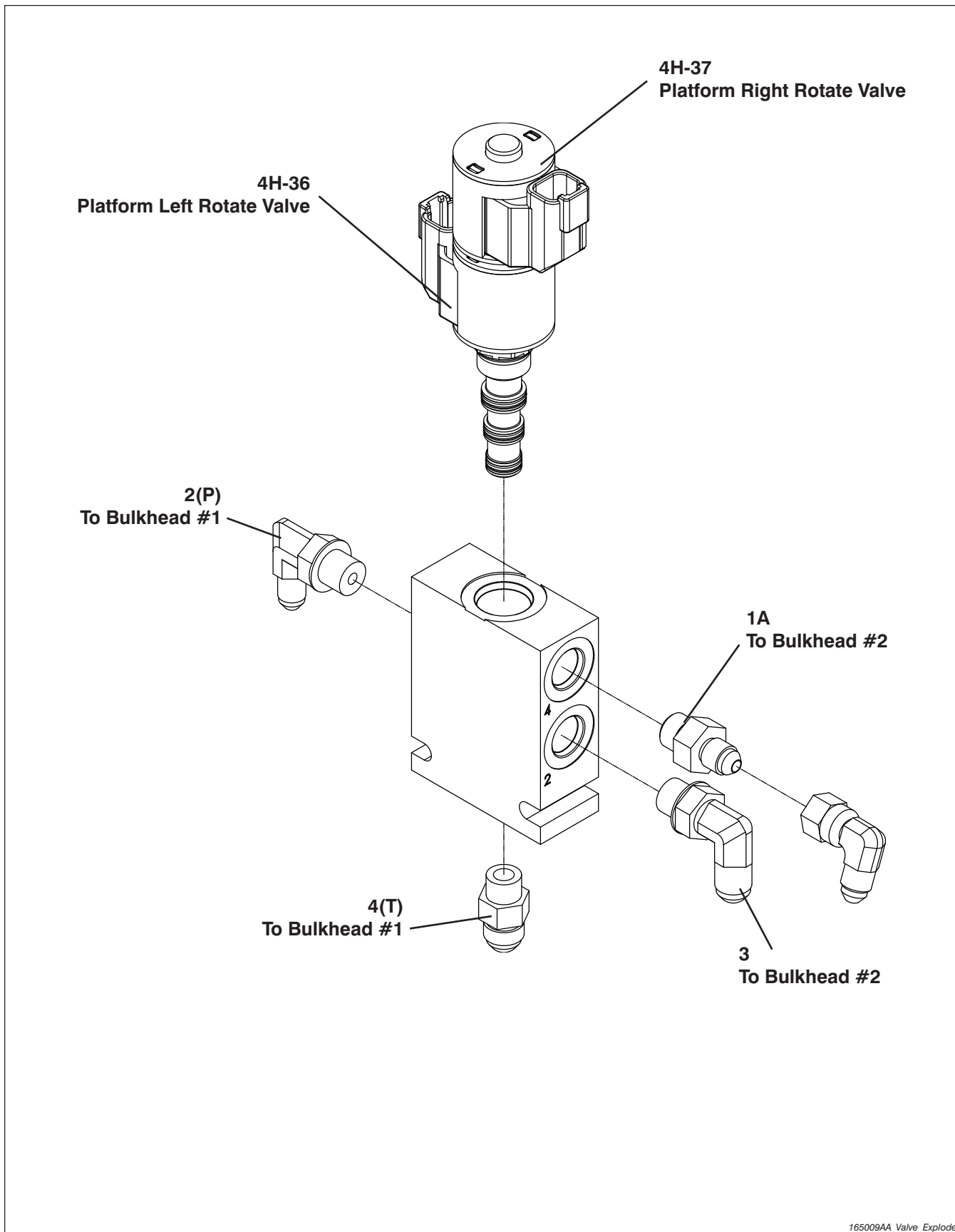

165009AA_Valve_Explode

3.22 Glow Plug Harness (Deutz D2011 Diesel Engine)

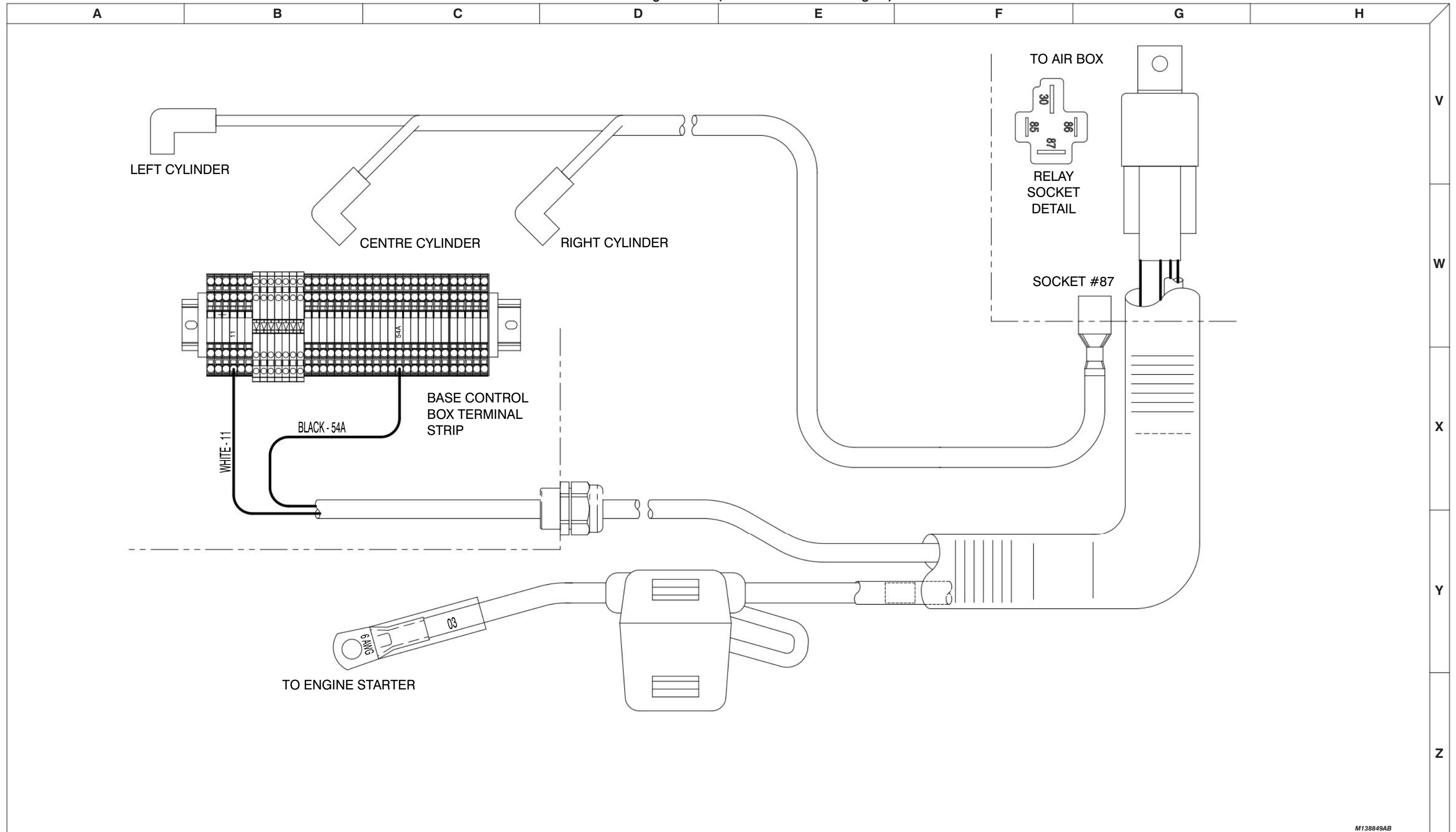

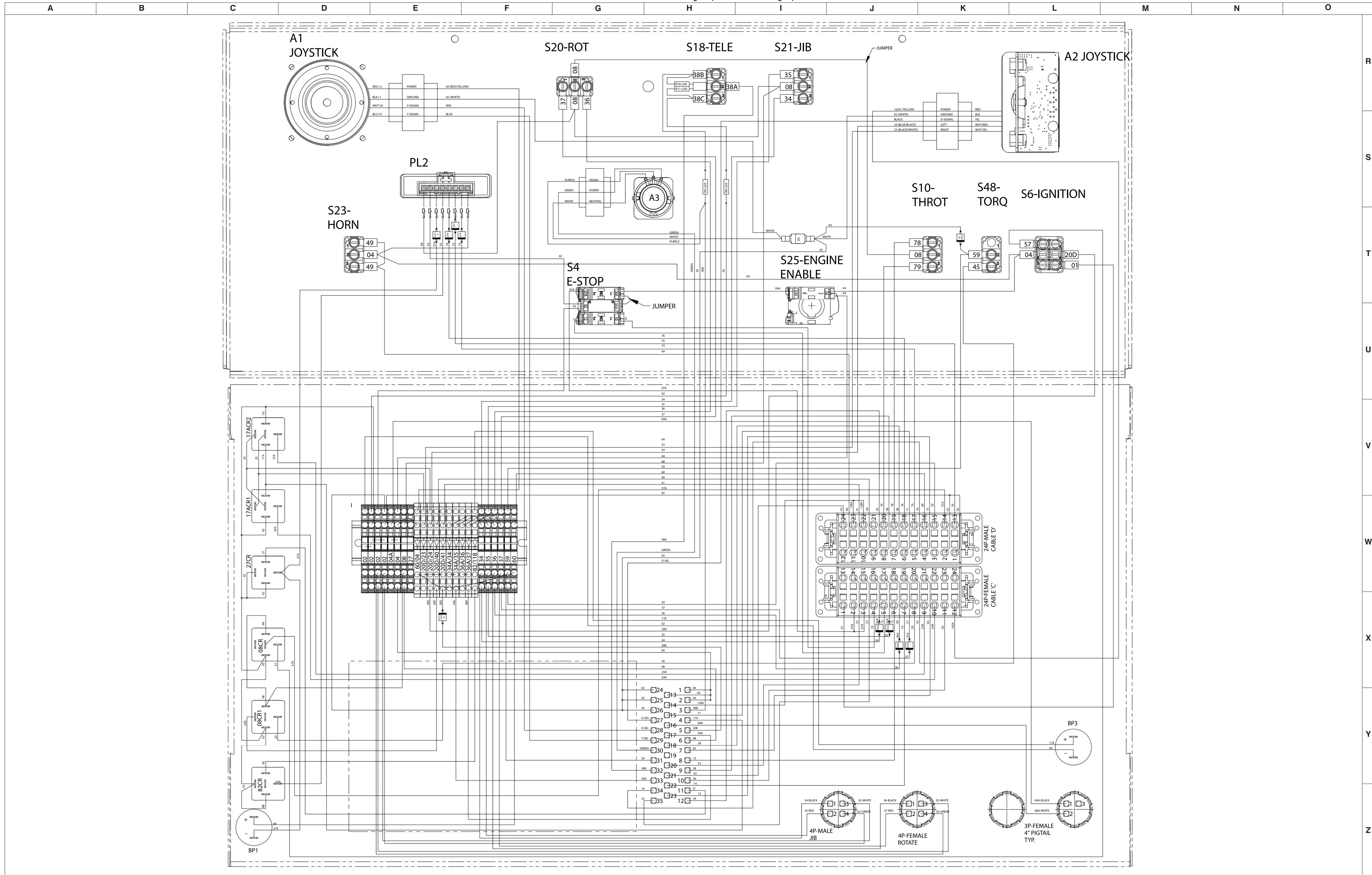

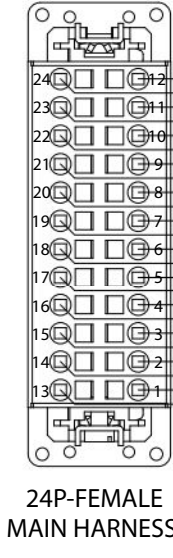
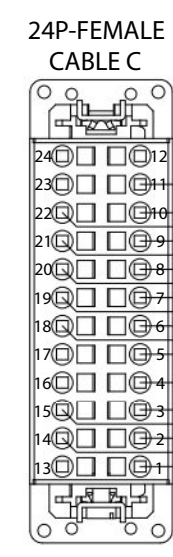
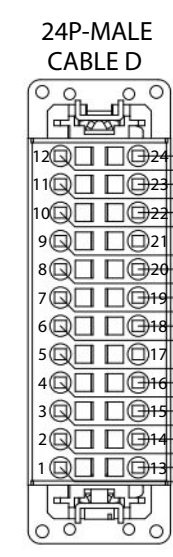
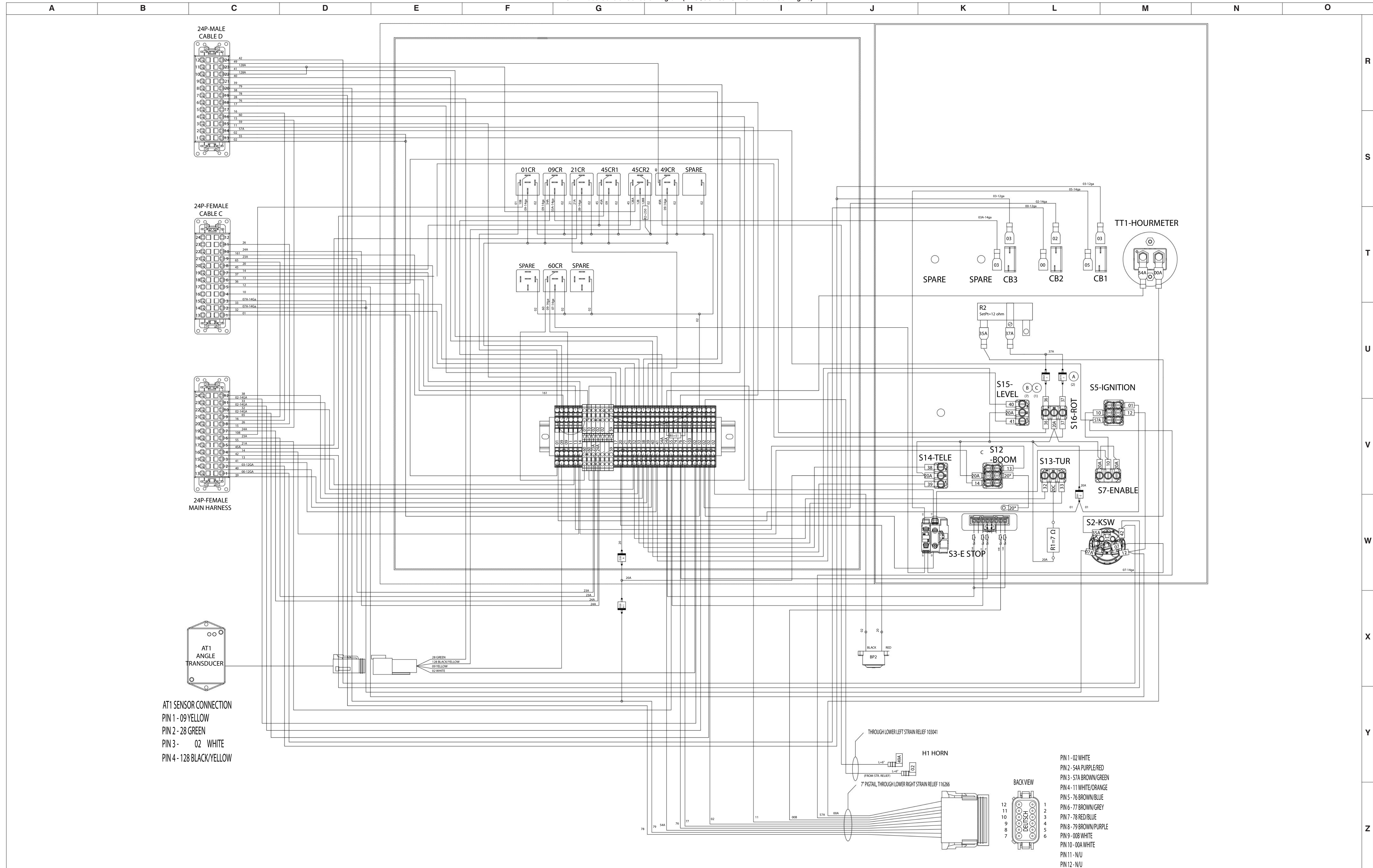

AT1 SENSOR CONNECTION
 PIN 1 - 09 YELLOW
 PIN 2 - 28 GREEN
 PIN 3 - 02 WHITE
 PIN 4 - 128 BLACK/YELLOW

- BACK VIEW
- PIN 1 - 02 WHITE
 - PIN 2 - 54A PURPLE/RED
 - PIN 3 - 57A BROWN/GREEN
 - PIN 4 - 11 WHITE/ORANGE
 - PIN 5 - 76 BROWN/BLUE
 - PIN 6 - 77 BROWN/GREY
 - PIN 7 - 78 RED/BLUE
 - PIN 8 - 79 BROWN/PURPLE
 - PIN 9 - 008 WHITE
 - PIN 10 - 00A WHITE
 - PIN 11 - NU
 - PIN 12 - NU

CLICK HERE TO **DOWNLOAD** THE COMPLETE MANUAL

- Thank you very much for reading the preview of the manual.
- You can download the complete manual from: www.heydownloads.com by clicking the link below



- Please note: If there is no response to CLICKING the link, please download this PDF first and then click on it.

CLICK HERE TO **DOWNLOAD** THE COMPLETE MANUAL

3.51 Flashing Amber Light Connection

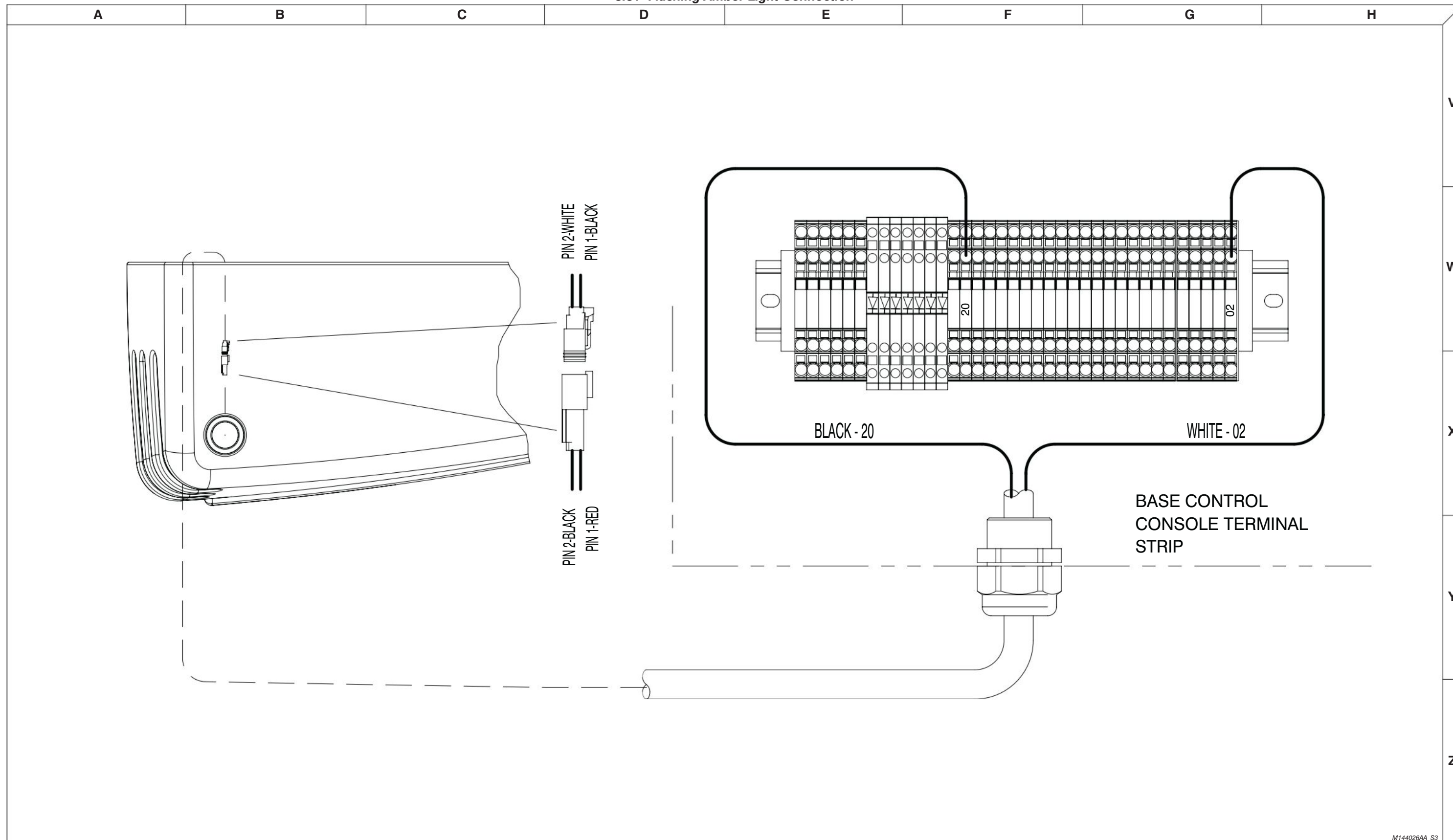

4.1-3 No Power to Base

1. Open or defective base key switch S2.
 - Select base position on key switch. Check continuity through base key switch. Replace if defective.
2. Loose or broken wire #12 from base key switch S2 to Ignition/E-pump switch S5.
 - Check continuity. Replace if defective.
3. Loose or broken wire #12 from base key switch S2 to base connector plug A pin #5.
 - Check continuity. Replace if defective.
4. Loose or broken wire #12 in boom cable A or its connectors.
 - Check for continuity between pins #5 on cable A. Check for loose or corroded connections on cable connectors. Replace if wire is defective.
5. Loose or broken wire #12 from plug A pin #5 to emergency stop switch S4 in platform control console.
 - Check continuity. Replace if defective.
6. Open or defective emergency stop switch S4.
 - Check switch is in on position. Check continuity through switch. Replace if defective.
7. Loose or broken wire #10 from emergency stop switch S4 to plug A pin #4.
 - Check continuity. Replace if defective.
8. Loose or broken wire #10 in boom cable A or its connectors.
 - Check for continuity between pins #4 on cable A. Check for loose or corroded connections on cable connectors. Replace if wire is defective.
9. Loose or broken wire #10 from plug A pin #4 to base terminal block.
 - Check continuity. Replace if defective.
10. Open or defective diode D10.
 - Check diode. Replace if defective.
11. Loose or broken wire #10 from base terminal block to Ignition/E-pump (enable) switch S5.
 - Check continuity. Replace if defective.
12. Open or defective Ignition/E-pump (enable) switch S5.
 - Check switch. Replace if defective

4.1-4 Engine Will Not Crank from Base

1. Loose or broken wire #57A from base start switch S5 to relay 57ACR (Deutz D2011 and GM 3.0l engines).
 - Check continuity. Replace if defective.
2. Defective base start switch S5.
 - Check start switch. Replace if defective.

4.1-5 Engine Will Not Crank from Platform

NOTE

Engine will not crank from platform with footswitch depressed.

1. Loose or broken wire #4 from emergency stop switch S4 to start switch S6.
 - Check continuity. Replace if defective.
2. Defective start switch S6.
 - Check continuity through switch. Replace if defective.
3. Loose or broken wire #57 from start switch S6 to relay 08CR.
 - Check continuity. Replace if defective.
4. Defective relay 08CR.
 - Check continuity through contacts of relay. Replace if defective.
5. Loose or broken wire #57A from relay 08CR to plug B pin #14.
 - Check continuity. Replace if defective.
6. Loose or broken wire #57A in boom cable B or its connectors.
 - Check for continuity between pin #14 on cable B. Check for loose or corroded connections on cable connectors. Replace if wire is defective.

4.1-22 No Platform Rotate Right from Base Control Console

1. Loose or broken wire #10A from ignition/ pump switch S5 to platform rotate switch S16.
 - Check continuity. Replace if defective.
2. Defective platform rotate switch S16.
 - Check continuity through switch while activating rotate right function between wires #10A and #37. If no continuity found, replace switch.
3. Open or defective diode D37-1.
 - Check diode. Replace if defective.
4. Loose or broken wire #37A from diode D37-1 to resistor R2.
 - Check continuity. Replace if defective.
5. Loose or broken wire #37 from platform rotate switch S16 to base connector plug A pin #19.
 - Check continuity. Replace if defective.
6. Loose or broken wire #37 in boom cable A or its connectors.
 - Check for continuity between pins #19 on cable A. Check for loose or corroded connections on cable connectors. Replace if wire is defective.
7. Loose or broken wire #37 plug A pin #19 to platform terminal block.
 - Check continuity. Replace if defective.
8. Loose or broken wire #37 from platform terminal block to platform rotate right valve 4H-37.
 - Check continuity. Replace if defective.
9. Loose or broken wire #02 from platform terminal block to platform rotate right valve 4H-37.
 - Check continuity. Replace if defective.
10. Defective platform rotate right valve coil 4H-37.
 - Check continuity and resistance through coil. Replace if defective.

4.1-23 No Platform Rotate Left or Right from Base Control Console

1. Open resistor R2.
 - Check resistor for 10 ohms (45T) or 13 ohms (40T). If no resistance found, replace resistor.
2. Loose or broken wire #35A from resistor R2 to base key switch S2.
 - Check continuity. Replace if defective.
3. Open or defective base key switch S2.
 - Select base control on switch. Check continuity through switch. Replace if defective.
4. Loose or broken wire #42 from base key switch S2 to turret harness plug pin #16.
 - Check continuity. Replace if defective.
5. Loose or broken wire #42 from turret harness plug pin #16 to proportional flow enable valve 2H-42.
 - Check continuity. Replace if defective.
6. Loose or broken wire #02 from turret harness plug to proportional flow enable valve 2H-42.
 - Check continuity. Replace if defective.
7. Defective proportional flow enable valve coil 2H-42.
 - Check continuity and resistance through coil. Replace if defective.

4.1-24 No Jib Up from Base Control Console

1. Loose or broken wire #10A from ignition/ pump switch S5 to jib switch S17.
 - Check continuity. Replace if defective.
2. Defective jib up switch S17.
 - Check continuity through switch while activating jib up function between wires #10A and #35. If no continuity found, replace switch.
3. Open or defective diode D35-1.
 - Check diode. Replace if defective.
4. Loose or broken wire #35A from diode D35-1 to resistor R2.
 - Check continuity. Replace if defective.
5. Loose or broken wire #35 from jib up switch S17 to base connector plug A pin #17.
 - Check continuity. Replace if defective.

4.1-43 Throttle Inoperative, Mid and High (Deutz D2.9L only)

1. Loose or broken wire #90 from base terminal block to connector J2 pin #5.
 - Check continuity. Replace if defective.
2. Loose or broken wire #90 from connector P2 pin #5 94 pin ECU connector pin 80.
 - Check continuity. Replace if defective.
3. Loose or broken wire #99 from base terminal block to connector J2 pin 4
 - Check continuity. Replace if defective.
4. Loose or broken wire #99 from connector P2 pin 4 to 94 pin ECU connector pin 74
 - Check continuity. Replace if defective.
5. Resistor R4 open or poor connection at base terminal block.
 - Measure resistance (1K Ω) between 99 and 99A. Check connections. Replace if defective.
6. Resistor R5 open or poor connection at base terminal block.
 - Measure resistance (3.3K Ω) between 99A and 99B. Check connections. Replace if defective.
7. Resistor R6 open or poor connection at base terminal block.
 - Measure resistance (3.9K Ω) between 99B and 90. Check connections. Replace if defective.

4.1-44 Mid Throttle Inoperative

1. Loose or broken wire #08 from platform terminal block to throttle switch S10.
 - Check continuity. Replace if defective.
2. Defective throttle switch S10.
 - Check continuity through switch while activating mid throttle function between wires #08 and #79. If no continuity found replace switch.
3. Loose or broken wire #79 from throttle switch S10 to plug B pin #20 in platform control console.
 - Check continuity. Replace if defective.
4. Loose or broken wire #79 in Cable B or its connectors.
 - Check for continuity between pins #20 on cable B. Check for loose or corroded connections on cable connectors. Replace if wire is defective.

(Deutz D2.9L Diesel Only)

5. Loose or broken wire #79 from base plug B pin #20 to relay 79CR.
 - Check continuity. Replace if defective.
6. Loose or broken wire #02 from base terminal block to relay 79CR.
 - Check continuity. Replace if defective.
7. Loose or broken wire #90 from relay 79CR to base terminal block.
 - Check continuity. Replace if defective.
8. Loose or broken wire #99B from relay 79CR to base terminal block.
 - Check continuity. Replace if defective.
9. Defective relay 79CR.
 - Check relay. Replace if defective.

(Deutz D2011 Diesel Only)

10. Loose or broken wire #79 from base plug B pin #20 to relay 79CR.
 - Check continuity. Replace if defective.
11. Loose or broken wire #02 from base terminal block to relay 79CR.
 - Check continuity. Replace if defective.
12. Loose or broken wire #99 from relay 79CR to ECU connector pin #18.
 - Check continuity. Replace if defective.
13. Loose or broken wire #103 from relay 79CR to base terminal block.
 - Check continuity. Replace if defective.
14. Loose or broken wire #103 from base terminal block to ECU connector pin #17.
 - Check continuity. Replace if defective.
15. Defective relay 79CR.
 - Check relay. Replace if defective.

2. Stuck or defective check valve CV9.
 - Clean valve. Check O-rings on valve. Check operation of valve. Repair or replace valve as required.
3. Stuck or defective jib up valve 4H-35.
 - Clean valve. Check operation of valve. Repair or replace valve as required.
4. Stuck or defective counterbalance valve CB9.
 - Clean valve. Check O-rings on valve. Repair or replace valve as required.
5. Defective jib cylinder C5.
 - Check seals on cylinder. Replace as necessary. Replace cylinder if defective.

4.2-10 No Jib Down

1. Stuck or defective proportional flow enable valve 2H-42.
 - Clean valve. Check O-rings on valve. Check operation of valve. Repair or replace valve as required.
2. Stuck or defective check valve CV9.
 - Clean valve. Check O-rings on valve. Check operation of valve. Repair or replace valve as required.
3. Stuck or defective jib down valve 4H-34.
 - Clean valve. Check operation of valve. Repair or replace valve as required.
4. Stuck or defective counterbalance valve CB8.
 - Clean valve. Check O-rings on valve. Repair or replace valve as required.
5. Defective jib cylinder C5.
 - Check seals on cylinder. Replace as necessary. Replace cylinder if defective.

4.2-11 No Platform Rotation Right

1. Stuck or defective proportional flow enable valve 2H-42.
 - Clean valve. Check O-rings on valve. Check operation of valve. Repair or replace valve as required.
2. Stuck or defective check valve CV9.
 - Clean valve. Check O-rings on valve. Check operation of valve. Repair or replace valve as required.
3. Stuck or defective rotate right valve 4H-37.
 - Clean valve. Check operation of valve. Repair or replace valve as required.
4. Stuck or defective counterbalance valve CB11.
 - Clean valve. Check O-rings on valve. Repair or replace valve as required.
5. Defective rotary actuator RA1.
 - Check actuator. Repair or replace as necessary.

4.2-12 No Platform Rotation Left

1. Stuck or defective proportional flow enable valve 2H-42.
 - Clean valve. Check O-rings on valve. Check operation of valve. Repair or replace valve as required.
2. Stuck or defective check valve CV9.
 - Clean valve. Check O-rings on valve. Check operation of valve. Repair or replace valve as required.
3. Stuck or defective rotate left valve 4H-36.
 - Clean valve. Check operation of valve. Repair or replace valve as required.
4. Stuck or defective counterbalance valve CB10.
 - Clean valve. Check O-rings on valve. Repair or replace valve as required.
5. Defective rotary actuator RA1.
 - Check actuator. Repair or replace as necessary.
 -

OCM Operating Values Chart

Input	Expected Value	Description
AI 1	0.5V to 8.5V	Drive Joystick
AI 2	0.5V to 8.5V	Turret Rotation Joystick
AI 3	0.5V to 8.5V	Boom Elevation Joystick
AI 4	0.5V to 7.5V	Flow Enable Rotary Potentiometer
DI 1	0 or 1	Direction Reverse Limit Sw.
DI 2	0 or 1	Footswitch Actuated
DI 3	0 or 1	Telescope Out Toggle Switch
DI 4	0 or 1	Telescope In Toggle Switch
DI 5	0 or 1	Jib Toggle Enabled
DI 6	0 or 1	Platform Rotation Toggle Enabled
DI 11	0 or 1	High Speed Drive Enable Limit Switch

Output	Adjustable Parameter	Description
PWM 1	25 to 75%	Drive Reverse
PWM 2	25 to 75%	Drive Forward
PWM 3	21 to 35%	Turret Rotate Left
PWM 4	21 to 35%	Turret Rotate Right
PWM 5	21 to 35%	Main Boom Down
PWM 6	38 to 47%	Main Boom Up
PWM 7	0 to 100%	Jib and Platform Rotate
PWM 11	40 to 48%	Boom Telescope Retract
PWM 12	45 to 70%	Boom Telescope Extend
Output	Expected Value	Description
DOUT 1	0 or 1	Steering Reverse Relay
DOUT 2	0 or 1	Load Sense Valve Enable
DOUT 3	0 or 1	Footswitch Actuated Indicator
DOUT 4	0 or 1	Holding Brake OFF (Energize to release)
DOUT 5	0 or 1	Manual Platform Level Enable

60583AB

Turret

5.3-1 High Pressure Filter Replacement

1. Start engine from base control console.
2. Inspect filter restriction indicator gauge. (The filter should be operating with the gauge pointing to the green area. If it is in the red area, the filter needs to be replaced)
3. Turn engine off.
4. Place a suitable container under filter.

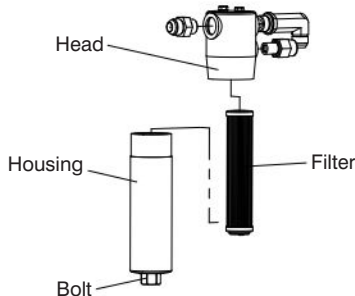

High Pressure Filter

5. Using a 30 mm box wrench, loosen bolt and remove high pressure filter housing from filter head.
6. Remove high pressure filter from filter head and install a new high pressure filter.
7. Apply hydraulic oil to the o-ring on the high pressure filter housing.
8. Reinstall filter and re-tighten bolt. For torque specification, refer to [Section 2](#).

5.3-2 Check Swing Drive Motor Gearbox Oil

1. Remove gearbox fill plug.
2. Check oil level (oil level should be slightly below the plug, see figure below). Add oil if needed. For oil specification, Refer to [Section 2](#).

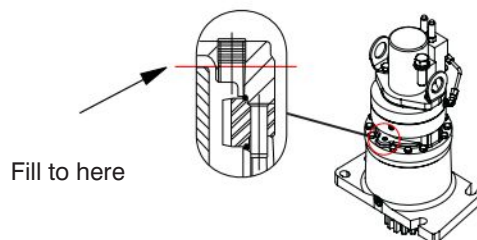

Gearbox Fill Port

5.3-3 Turret Rotation Gear Backlash Adjustment

The swing drive motor is located in the engine compartment.

NOTE

The adjustment of the backlash must be performed on a flat level surface.

1. Ensure aerial platform is on a firm level surface.

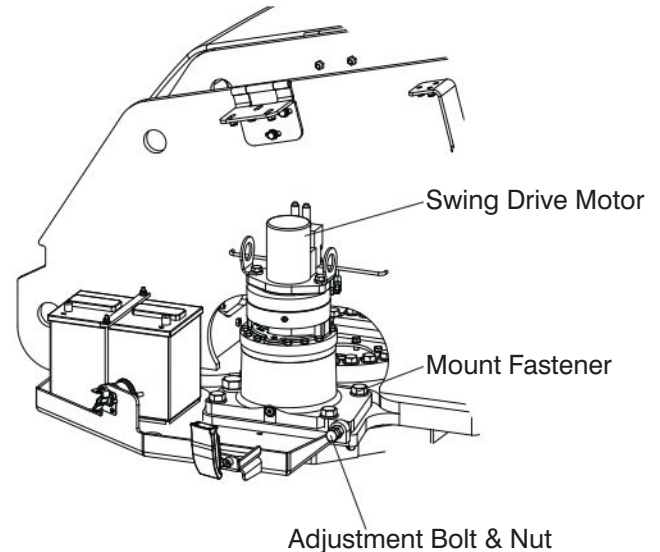

Swing Drive Assembly

2. Loosen mounting fasteners on the swing drive motor.
3. Push the swing drive motor towards the turret as close as possible. (this will push the rotation gear into the rotation bearing)
4. Loosen lock nut on adjustment bolt.
5. Tighten adjustment bolt clockwise until it contacts the plate of gearbox.
6. Turn adjustment bolt $\frac{1}{2}$ turn counterclockwise, then tighten lock nut on adjustment bolt.
7. Pull swing drive motor away from turret until it contacts the adjustment bolt.
8. Tighten mounting fasteners on swing drive motor.
7. Rotate turret through an entire rotation and check for a smooth rotation of the turret.

5.4-6 Deutz D2.9L Fault Codes

Code	SPN	FMI	Blink Code	Error Identification
122	523698	11	5-9-1	Shut off request from supervisory monitoring function.
124	523969	11	7-7-4	Fault entry for override control mode.
125	523717	12	5-9-5	Timeout error of CAN-transmit-frame AmbCon; Weather environments.
126	523603	9	3-3-8	Timeout Error of CAN-receive-frame AMB; Ambient temperature sensor.
128	3224	9	5-9-7	Timeout error of CAN-receive-frame AT1IG1; NOX sensor upstream.
129	3224	2	5-9-6	DLC error of CAN-receive-frame AT1IG1Vol NOX sensor.
130	3224	9	5-9-7	Timeout error of CAN-receive-frame AT1IG1Vol; NOX sensor.
133	523938	9	7-6-6	Timeout error (BAM to packet) for CAN-receive-frame AT1IGCVol1.
134	523939	9	7-6-6	Broadcast announce message of the calibration message of the upstream catalytic NOx sensor has failed.
135	523940	9	7-6-6	Timeout error (PCK2PCK) for CAN-Receive-Frame AT1IGCVol1.
136	3234	2	1-1-4	DLC error of CAN-Receive-Frame AT1O1.
137	3234	9	1-1-7	Timeout error of CAN-Receive-Frame AT1OG1. NOX sensor (SCR-system downstream cat; DPF-system downstream cat).
138	3234	2	1-1-4	DLC error of CAN-Receive-Frame AT1O1Vol.
139	3234	9	1-1-7	Timeout error of CAN-Receive-Frame AT1OG1Vol.
140	523941	9	7-6-7	Timeout error (BAM to packet) for CAN-Receive-Frame AT1OGCVol2.
141	523942	9	7-6-7	Calibration message 1 of the after catalyst Nox sensor has failed.
142	523943	9	7-6-7	Timeout error (PCK2PCK) for CAN-Receive-Frame AT1OGCVol2.
153	523992	9	7-9-3	Not used.
155	0	0	-	Not used.
164	523211	9	3-3-1	Timeout error of CAN-Receive-Frame EBC1.
167	523704	12	6-1-5	Timeout error of CAN-Transmit-Frame EEC3.
168	523935	12	7-6-3	Timeout error of CAN-Transmit-Frame EEC3VOL1. Engine send messages.
169	523936	12	7-6-4	Timeout error of CAN-Transmit-Frame EEC3VOL2. Engine send messages.
171	523212	9	3-3-3	Timeout error of CAN-Receive-Frame ComEngPrt. Engine Protection.
172	523741	14	6-1-8	Engine shut off request through CAN.
174	523213	12	3-3-4	Timeout error of CAN-Transmit-Frame ERC1.
178	523706	12	6-2-3	Timeout error of CAN-Transmit-Frame FIEco.
179	523240	9	5-2-7	Timeout CAN-message FunModCtl. Function Mode Control.
193	523937	9	7-6-5	Timeout DFC for NOxSensGlbReqTx.
196	3227	2	6-3-8	DFC SAE J1939 error.
198	523216	9	3-3-7	Timeout error of CAN-Receive-Frame PrHtEnCmd. Pre-heat command, engine command.
202	523793	9	6-7-8	Timeout error of CAN-Receive-Frame UAA10. AGS sensor service message.
203	523794	9	6-7-8	Timeout error of CAN-Receive-Frame UAA11. AGS sensor data.
212	523803	9	6-7-8	Timeout error of CAN-Receive-Message RxEngPres. Status Burner Air Pump.

1513AA-3

5.4-6 Deutz D2.9L Fault Codes

Code	SPN	FMI	Blink Code	Error Identification
970	624	12	5-1-3	SVS lamp: powerstage over temperature
971	624	3	5-1-3	SVS lamp; short circuit to battery
972	624	4	5-1-3	SVS lamp; short circuit to ground
973	523612	14	5-5-5	Softwarereset CPU SWReset_0
974	523612	14	5-5-5	Softwarereset CPU SWReset_1
975	523612	14	5-5-5	Softwarereset CPU SWReset_2
976	91	11	2-2-6	Plausibility error between APP1 and APP2 or APP1 and idle switch.
978	29	2	1-2-6	Plausibility error between sensor and idle switch, Acceleratio Pedal Detection. In case of Hand Throttle with Low Idle Switch, it is the plausibility check between hand throttle and idle switch.
980	523550	12	5-1-5	Terminal 50 was operated too long.
981	172	3	2-2-6	Air flow temperature sensor; short circuit to battery or open load.
982	172	4	2-2-6	Air flow temperature sensor; short circuit to ground.
986	523921	0	7-1-4	Burner temperature, temperature above upper shutoff threshold.
989	523921	1	7-1-4	Burner temperature, temperature below lower shutoff threshold.
992	105	1	1-2-8	Charged Air cooler down stream temperature. Temperature below lower physical threshold.
994	105	3	1-2-8	Electrical error charged air temperature. Signal range check high.(SRC)
995	105	4	1-2-8	Electrical error charged air temperature. Signal range check low.
996	105	0	2-3-3	Charged air cooler temperature. System reaction initiated. High charged air cooler temperature. Warning threshold exceeded.
997	105	0	2-3-3	High charged air cooler temperature. Shut off threshold exceeded.
998	105	11	1-2-8	Diagnostic fault check for charged air cooler downstream temperature sensor No detailed information!
1007	412	3	6-8-2	Electrical error EGR cooler downstream temperature. Signal range check high.
1008	412	4	6-8-2	electrical error EGR cooler downstream temperature. Signal range check low.
1011	523960	0	7-7-1	Physical range check high for EGR cooler downstream temperature.
1012	523960	1	7-7-1	Physical range check low for EGR cooler downstream temperature.
1014	51	6	5-9-4	Actuator error EGR-Valve (2.9;3.6) or Throttle-Valve (4.1;6.1;7.8). Signal range check high.
1015	520521	5	5-9-4	Actuator error EGR-Valve (2.9;3.6) or Throttle-Valve (4.1;6.1;7.8); signal range check low.
1016	51	7	5-9-4	Actuator position for EGR-Valve (2.9;3.6) or Throttle-Valve (4.1;6.1;7.8) not plausible.
1022	51	6	5-9-4	Actuator error EGR-Valve (2.9;3.6) or Throttle-Valve (4.1;6.1;7.8); signal range check high

1513AA-13

5.5-3 Throttle Actuator

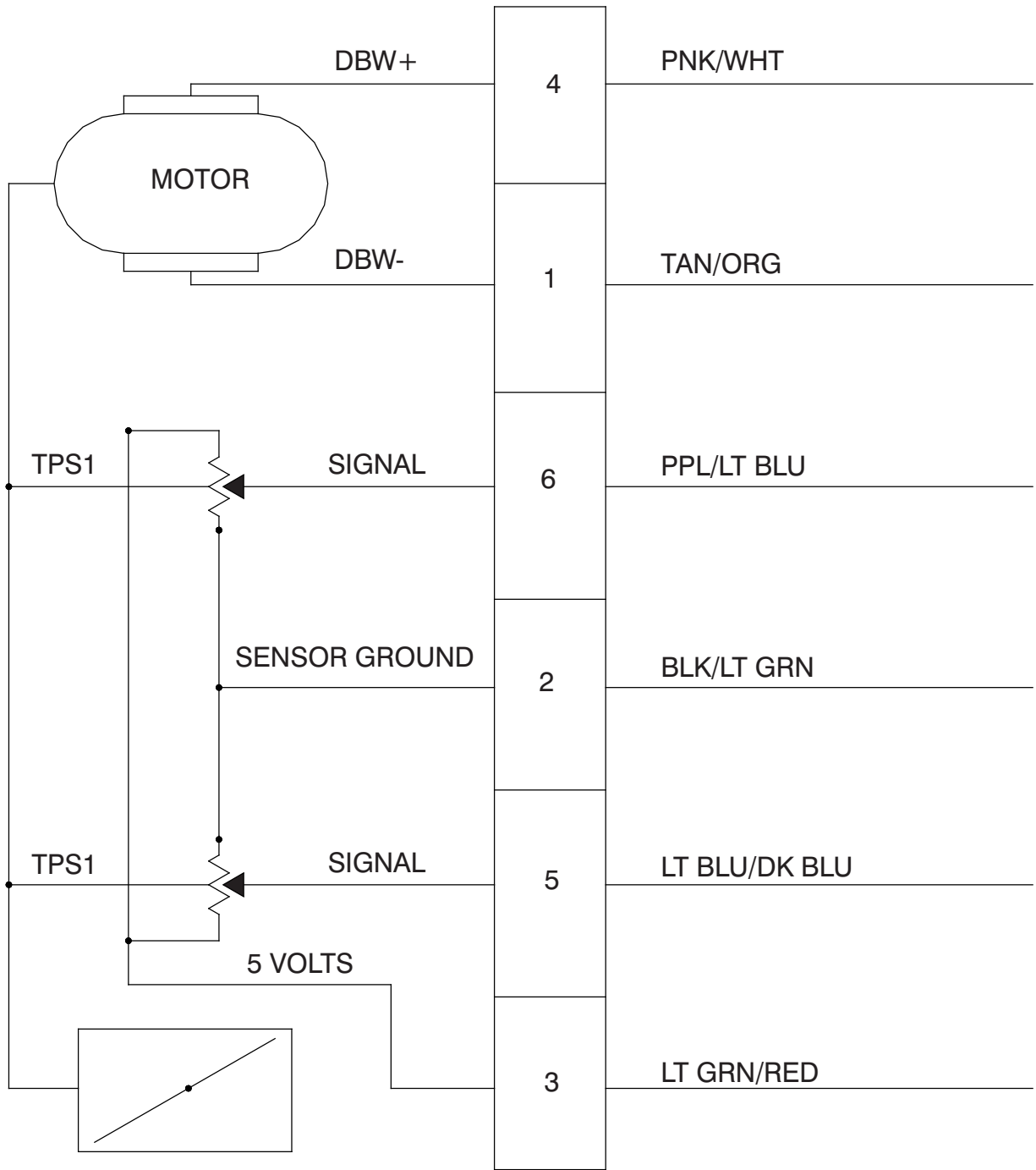

5.7-7 Fly Boom Relief Valve Adjustment

1. Locate the GP2 port on the main manifold and remove the cap.

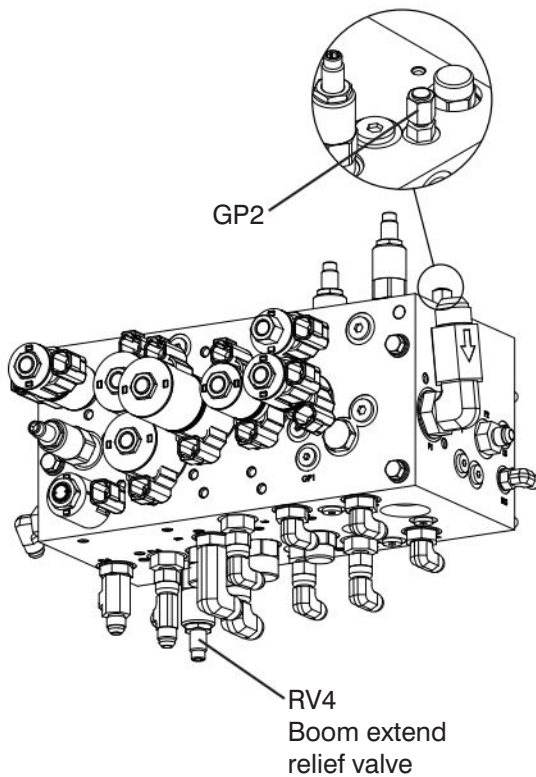
**Main Manifold**

2. Connect a pressure gauge (5000 psi) to the GP2 port.
3. Start the engine from the base control console and let it run for 2-5 minutes.
4. Fully extend the boom and check the reading on the gauge. Pressure should be 1500 psi. Follow the next steps for adjusting pressure if needed.
5. Locate the fly boom relief valve RV4.
6. Loosen the lock nut on fly boom relief valve RV4. Turn the adjusting stem clockwise to increase pressure and counterclockwise to decrease pressure.
7. Tighten the lock nut on the fly boom relief valve RV4 once 1500 psi is observed on the gauge. You must fully extend boom to activate pressure reading on gauge.

5.7-8 Test Charge Pump Pressure on Drive Pump

1. Locate test port TP3 on drive pump.
2. Connect a pressure gauge (600 psi) to test port.

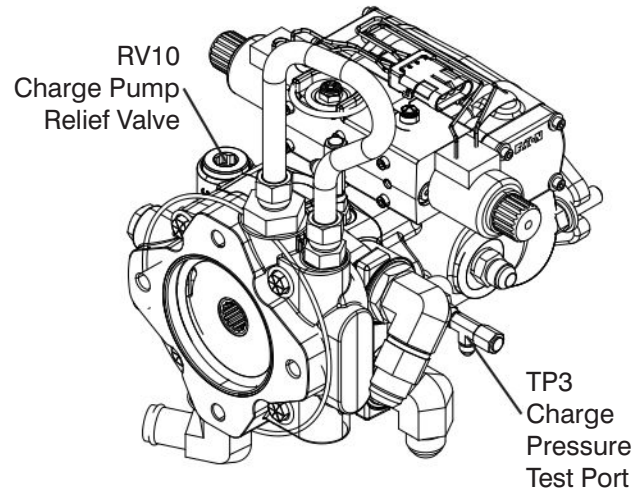
**Drive Pump - TP3**

3. Start engine from base control console.

**WARNING**

Do not activate any controls during procedure to protect gauge.

4. Check reading on gauge (standard pressure should be $313 \pm 10\%$ psi.)
5. Replace charge pump relief valve RV10 if pressure is not achieved.
6. Repeat steps 2, 3, and 4 after charge pump relief valve is replaced.
7. If pressure still not in range, repair or replace the pump as necessary.

CLICK HERE TO **DOWNLOAD** THE COMPLETE MANUAL

- Thank you very much for reading the preview of the manual.
- You can download the complete manual from: www.heydownloads.com by clicking the link below



- Please note: If there is no response to CLICKING the link, please download this PDF first and then click on it.

CLICK HERE TO **DOWNLOAD** THE COMPLETE MANUAL