

SW880/990

SHOP MANUAL

SAKAI®

3498-65684-0

CLICK HERE TO **DOWNLOAD** THE COMPLETE MANUAL

- Thank you very much for reading the preview of the manual.
- You can download the complete manual from: www.heydownloads.com by clicking the link below



- Please note: If there is no response to CLICKING the link, please download this PDF first and then click on it.

CLICK HERE TO **DOWNLOAD** THE COMPLETE MANUAL

2-7-1. Exact meter indicator lamp does not illuminate (during driving) (2/2).....	11-097
2-7-2. No vehicle speed indication on the display.....	11-099
2-8. Water Spray.....	11-101
2-8-1. Continuous water spray cannot be performed (1/4).....	11-101
2-8-1. Continuous water spray cannot be performed (2/4).....	11-103
2-8-1. Continuous water spray cannot be performed (3/4).....	11-105
2-8-1. Continuous water spray cannot be performed (4/4).....	11-107
2-8-2. Continuous water spray works, but intermittent water spray cannot be performed.....	11-109
2-8-3. Continuous water spray works, but automatic water spray cannot be performed.....	11-111
2-9. Lighting.....	11-113
2-9-1. Headlamps and working lamps do not light.....	11-113
2-9-2. Illumination of combination meter does not turn on.....	11-115
2-9-3. Combination meter warning lamp or indicator lamp is abnormal.....	11-115
2-9-4. Tachometer reading is abnormal (1/2).....	11-117
2-9-4. Tachometer reading is abnormal (2/2).....	11-119
2-9-5. Hour meter is abnormal.....	11-119
2-9-6. Temperature gauge is abnormal.....	11-121
2-9-7. Fuel gauge is abnormal.....	11-123
2-9-8. Hydraulic oil filter warning lamp remains ON.....	11-123
2-9-9. Oil pressure warning lamp remains ON.....	11-125
2-9-10. Charge warning lamp remains ON.....	11-127
2-9-11. Vibration indicator lamp does not light.....	11-127
2-9-12. Water spray indicator lamp does not light.....	11-129
2-9-13. Working lamp indicator lamp does not light.....	11-131
2-9-14. Parking brake indicator lamp does not light.....	11-131
2-9-15. Horn does not sound.....	11-133
2-9-16. Back buzzer does not sound.....	11-133
3. HYDRAULIC SYSTEM TROUBLESHOOTING.....	11-134
3-1. When Performing Hydraulic System Troubleshooting.....	11-134
3-2. Propulsion.....	11-135
3-2-1. Vehicle moves neither forward nor backward (1/2).....	11-135
3-2-1. Vehicle moves neither forward nor backward (2/2).....	11-136
3-2-2. Vehicle moves in one direction only (forward or backward).....	11-136
3-2-3. Slow vehicle speed or small drive force.....	11-136
3-2-4. Vehicle does not stop completely with forward/reverse lever in neutral position.....	11-137
3-2-5. Propulsion system is overheating.....	11-137

- Observe all product safety regulations when handling fuel, oils, grease, engine coolant and other chemical substances. Be careful especially when these items are hot as there is a risk of burning or scalding.
- Operate internal combustion engines and fuel operated heating systems only in adequately ventilated premises. Before starting the engine in an enclosed area, make sure there is sufficient ventilation.



1-11. Transporting the Machine

- Use only suitable and approved trailers and haul vehicles and lifting equipment of sufficient capacity.
- Entrust to experienced personnel the fastening and lifting of loads and instructing of crane operators.
- Only experienced persons familiar with the operation of the machine may load and unload the machine.
- Use ramps or a loading dock when loading or unloading the machine. Ramps must be the proper strength, low angle and the proper height and width.
- Block the drums (front and rear) of the hauling vehicle when loading and unloading the compactor. Ensure that the haul vehicle is on level ground and approach the loading ramps squarely to make sure that the compactor does not slide off the edge of the ramp.
- Keep the deck clear of mud, oil, ice or snow or other materials that can make the deck slippery.
- Position the compactor on the trailer or transport vehicle centered from side to side, and apply the brake. Shut off the engine and lock all lockable compartments.
- Block the drums and lock the articulation lock bar. Chain the machine down properly using the appropriate tackle.
- Know the overall height of the compactor and hauling vehicle. Observe height and weight regulations and be sure you can pass safely at overhead obstructions.
- Obey all traffic regulations and be sure that the proper clearance flags, lights and warning signs including "Slow Moving Vehicle" emblem are displayed when traveling on public roads.
- Know the approximate stopping distance at any given speed.
- Drive Safely. Never turn corners at excessive speeds.

2-3. Hydraulic System

Classification	Item	Standard value	Remarks	
Hydraulic system	Propulsion circuit	Relief valve pressure setting	40.2 ± 1.0 MPa (5,829 ± 145 psi)	Differential pressure
		Pressure override valve pressure setting	37.3 ± 1.0 MPa (5,409 ± 145 psi)	Differential pressure
		Charge relief pressure setting	2.5 ± 0.2 MPa (362 ± 29 psi)	
		Propulsion motor drainage (front drum)	Less than 10 L/min (Less than 2.6 gal./min)	Allowable maximum value (at maximum rotation)
		Propulsion motor drainage (rear drum)	Less than 10 L/min (Less than 2.6 gal./min)	Allowable maximum value (at maximum rotation)
		Front motor brake release pressure	1.5 – 3.9 MPa (218 – 566 psi)	
		Rear motor brake release pressure	1.5 – 3.9 MPa (218 – 566 psi)	
	Vibration circuit	Relief valve pressure setting	31.5 ± 1.0 MPa (4,568 ± 145 psi)	Differential pressure
		Charge relief pressure setting	2.5 ± 0.2 (362 ± 29 psi)	
		Port relief valve pressure setting	34.0 ± 1.0 MPa (4,930 ± 145 psi)	
		Vibrator motor drainage	Less than 6.4 L/min (Less than 1.7 gal./min)	Allowable maximum value (at maximum rotation)
		Steering circuit (Orbitrol relief pressure setting + charge relief pressure setting)	17.5 ± 1.0 MPa (2,451 ± 145 psi)	

2-4. Steering

Classification	Item	Standard value	Remarks
Steering	Play in steering wheel	5 – 10 mm (0.2 – 0.4 in.)	Steering wheel circumference
		Less than 0.5 mm (less than 0.02 in.)	Steering column shaft direction

1-3. Fuel System

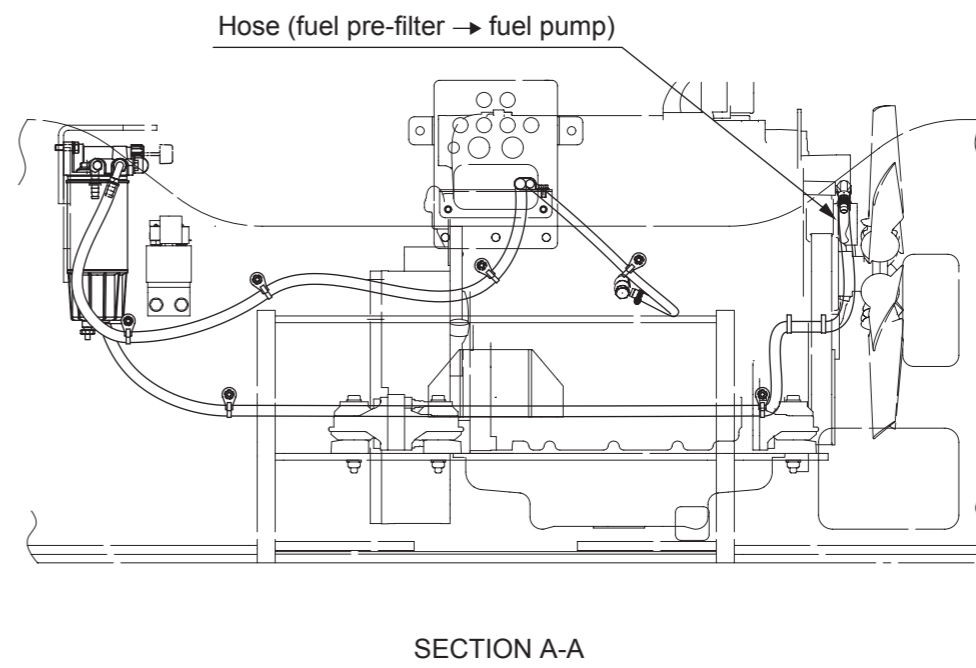
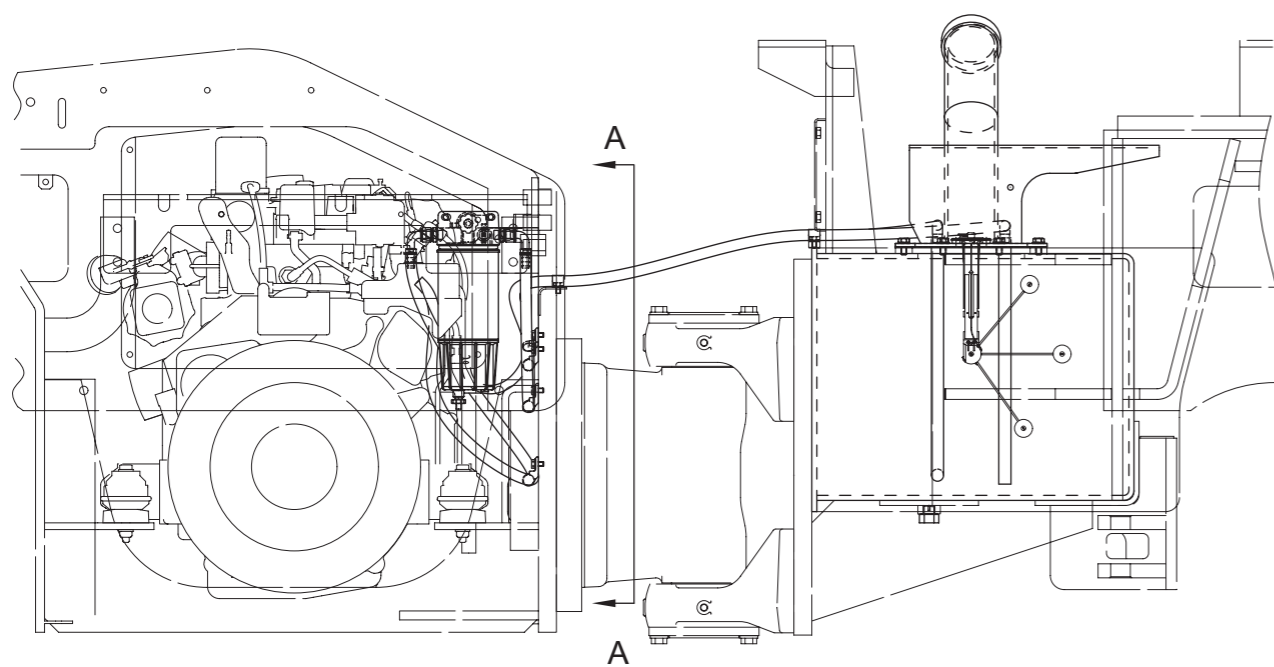
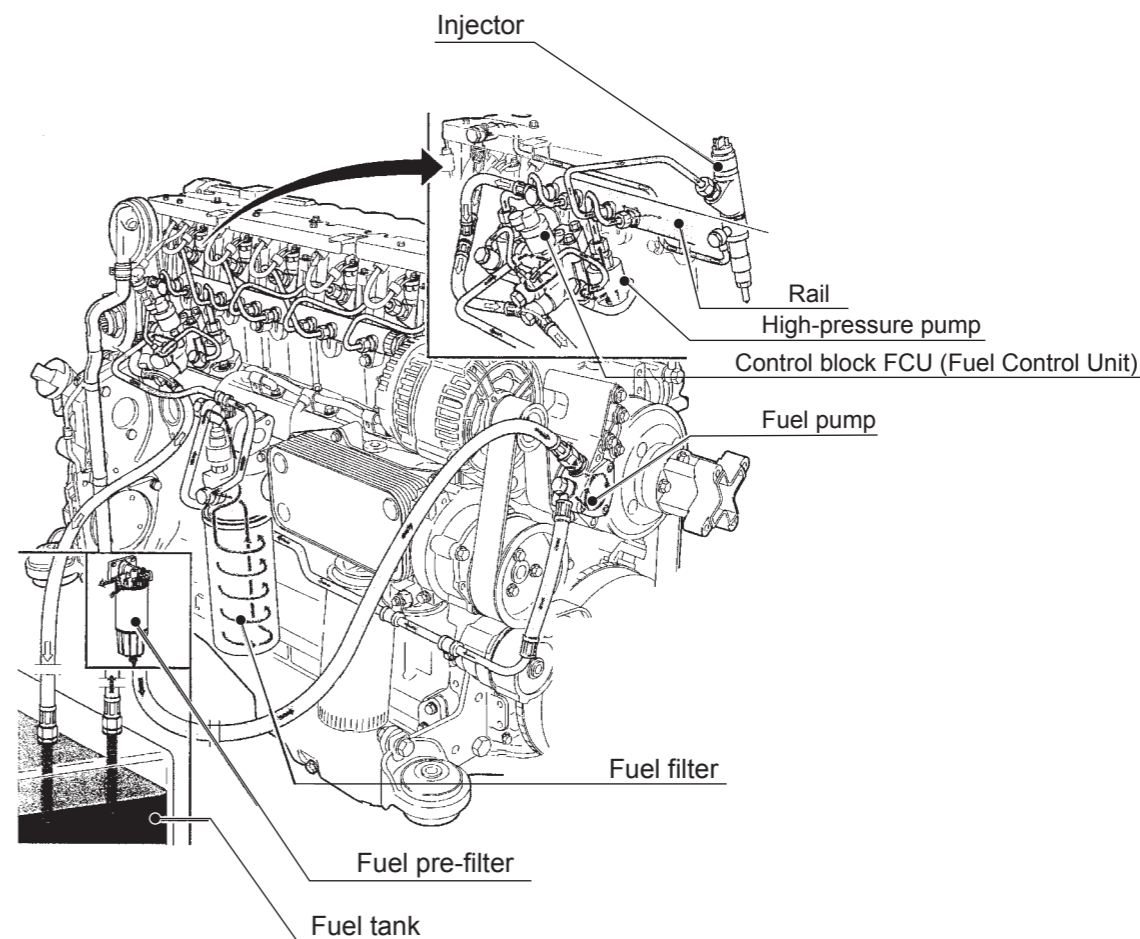
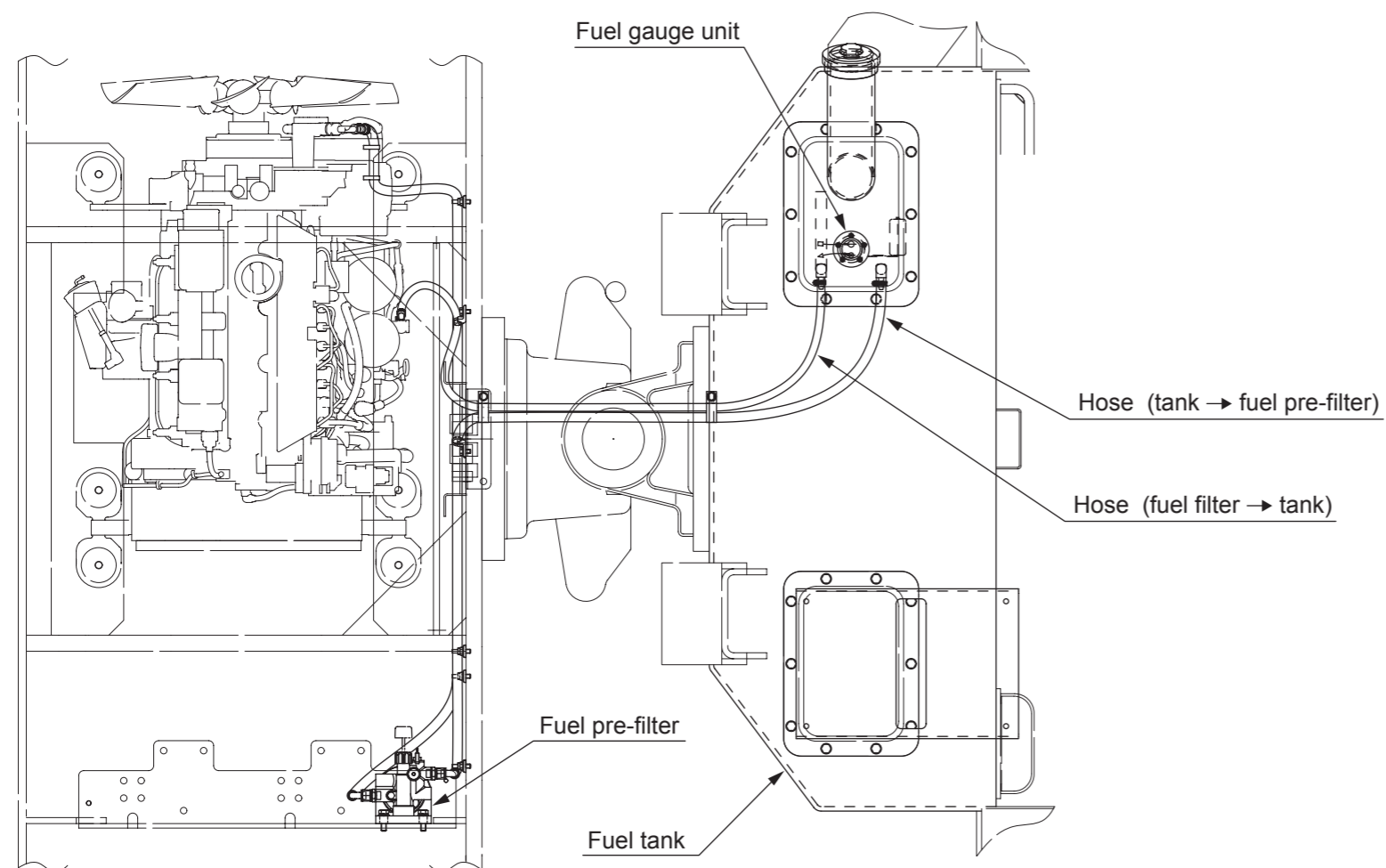

(4) Control module

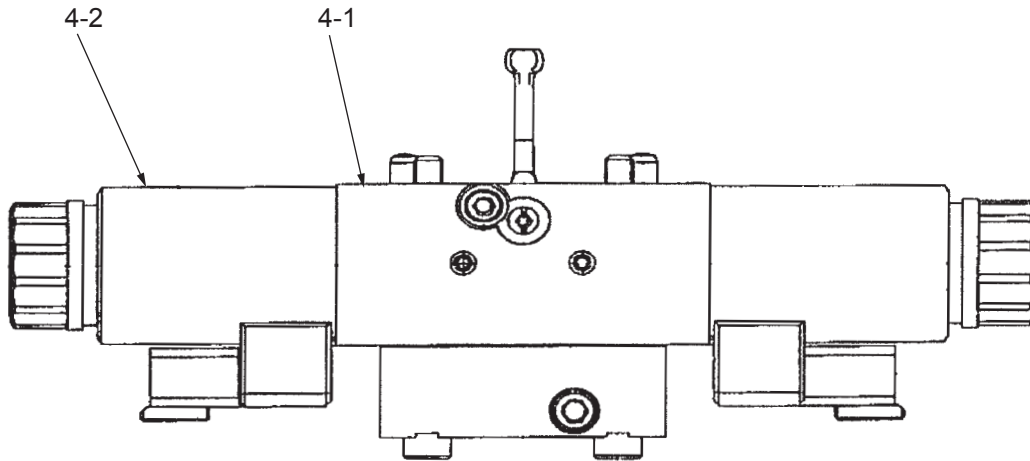

SW330-04032

- (4-1) Control module
- (4-2) Proportional solenoid

(5) Internal gear pump

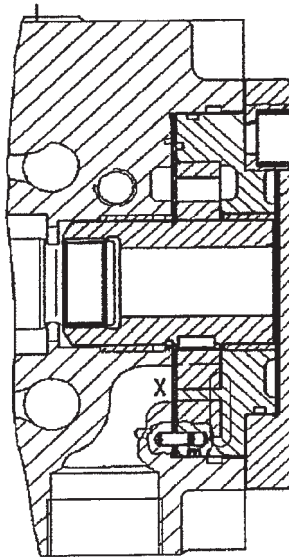

SW880-04033

4-2. Steering Wheel

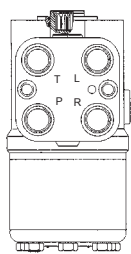
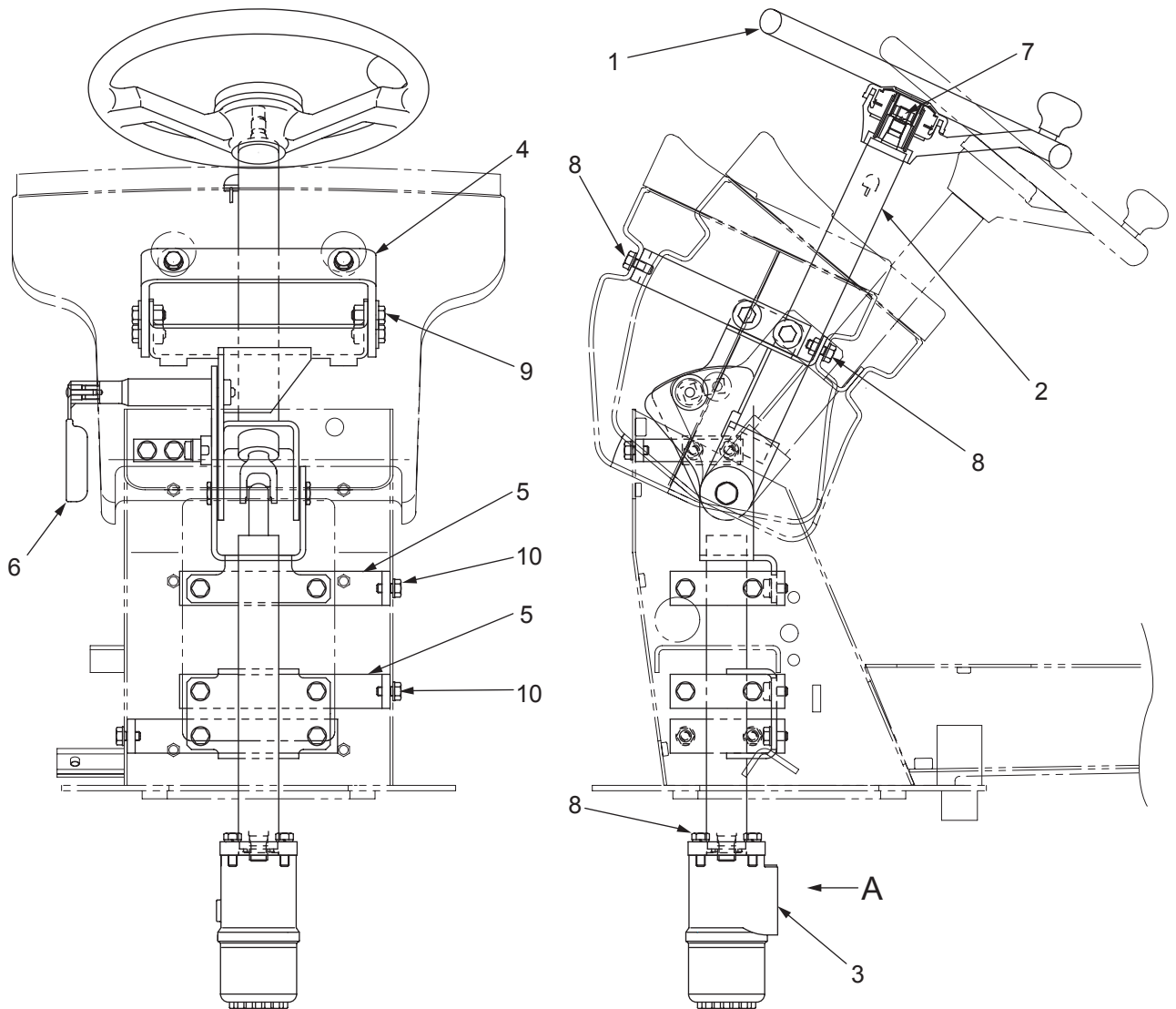

VIEW A

0568-32801-0-20070-0

- (1) Steering wheel
- (2) Column shaft
- (3) Orbitrol
- (4) Bracket
- (5) Bracket
- (6) Tilt lock handle



- (7) Nut M12 P=1.25 : 88 N·m (65 lbf-ft)
- (8) Bolt M10×25 : 49 N·m (36 lbf-ft)
- (9) Bolt M10×30 : 49 N·m (36 lbf-ft)
- (10) Bolt M10×20 : 49 N·m (36 lbf-ft)

• Steering wheel assembly weight : 28 kg (62 lbs.)

1-1-1. Engine-related electrical wiring diagram

Start switch position \ Terminal	B	R1	R2	ACC	BR	C
R1	○	○	○	○	○	
OFF						
ACC	○			○	○	
ST	○	○	○	○	○	○

Starter switch internal connection

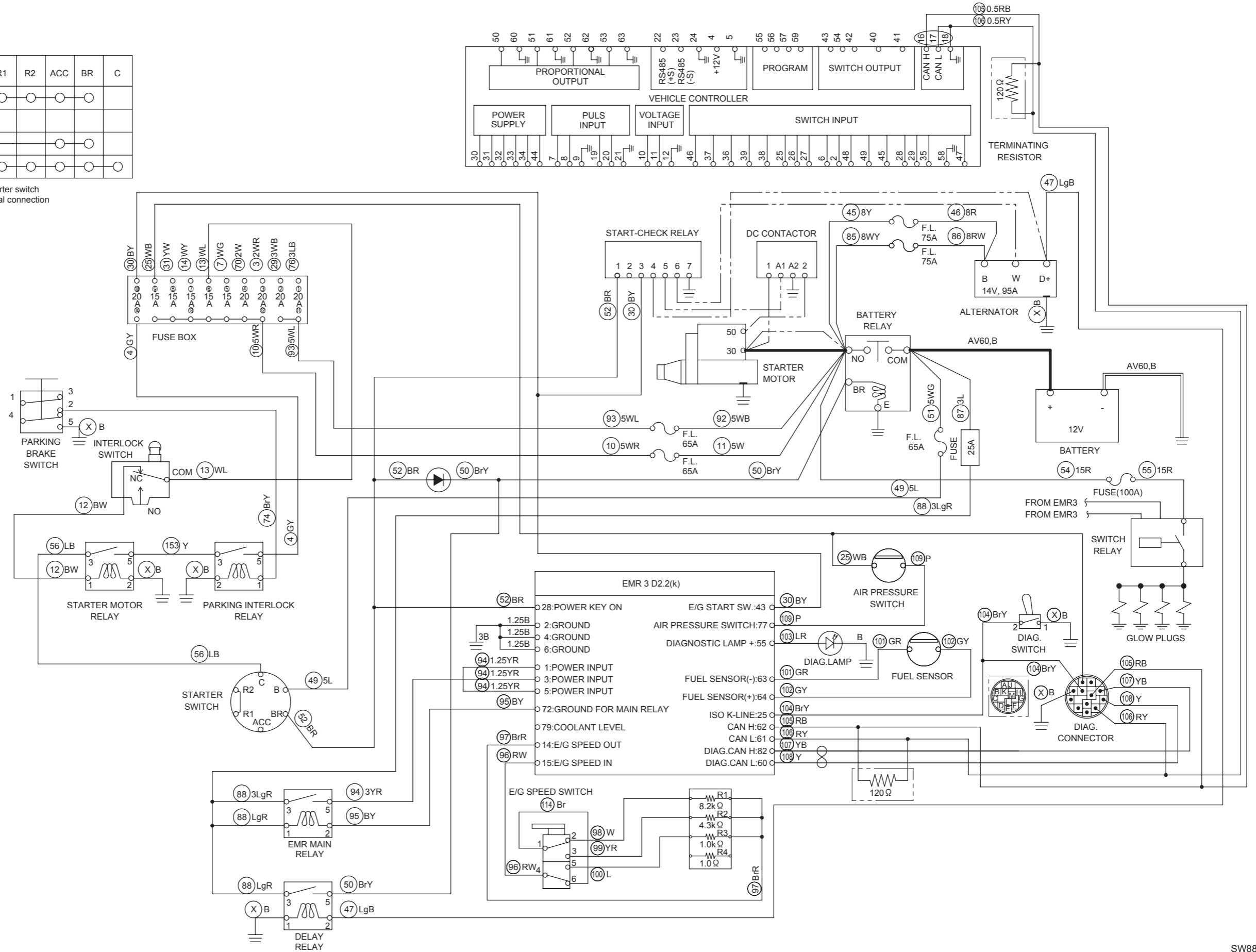

- (1) Vibratory drum selector switch
- (2) High/low-vibration selector switch
- (3) Vibration frequency selector switch
- (4) IPF selector switch
- (5) Automatic speed indicator lamp
- (6) Exact meter
- (7) Vibration mode (continuous/automatic) selector switch
- (8) Combination meter
- (9) Engine diagnostic switch
- (10) Engine check lamp
- (11) Emergency propulsion switch
- (12) Parking brake switch
- (13) Lighting switch
- (14) Speed switch
- (15) Throttle switch
- (16) Starter switch
- (17) Vibrator switch
- (18) Automatic speed setting switch
- (19) Water spray switch
- (20) Forward-reverse lever
- (21) Water spray timer
- (22) Timer switch
- (23) Water spray mode (continuous/automatic) selector switch
- (24) Front water spray pump selector switch
- (25) Rear water spray pump selector switch
- (26) Potentiometer
- (27) Forward-reverse lever switch
- (28) Back buzzer switch
- (29) Foot brake switch
- (30) Fuse box
- (31) Diagnostic connector
- (32) Programming connector
- (33) Neutral relay
- (34) Parking interlock relay
- (35) Starter motor relay
- (36) Lamp check relay
- (37) Delay relay
- (38) EMR main relay
- (39) Foot brake relay
- (40) Diode
- (41) Water spray 2 relay
- (42) Water spray 1 relay
- (43) Horn relay
- (44) Neutral holding relay
- (45) Neutral relay
- (46) Resistor unit

3-8. Lever Switch

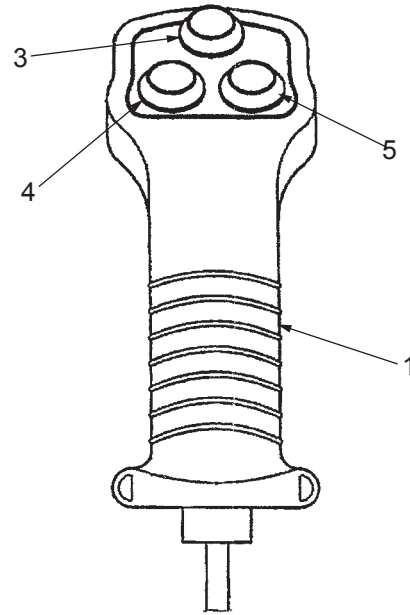
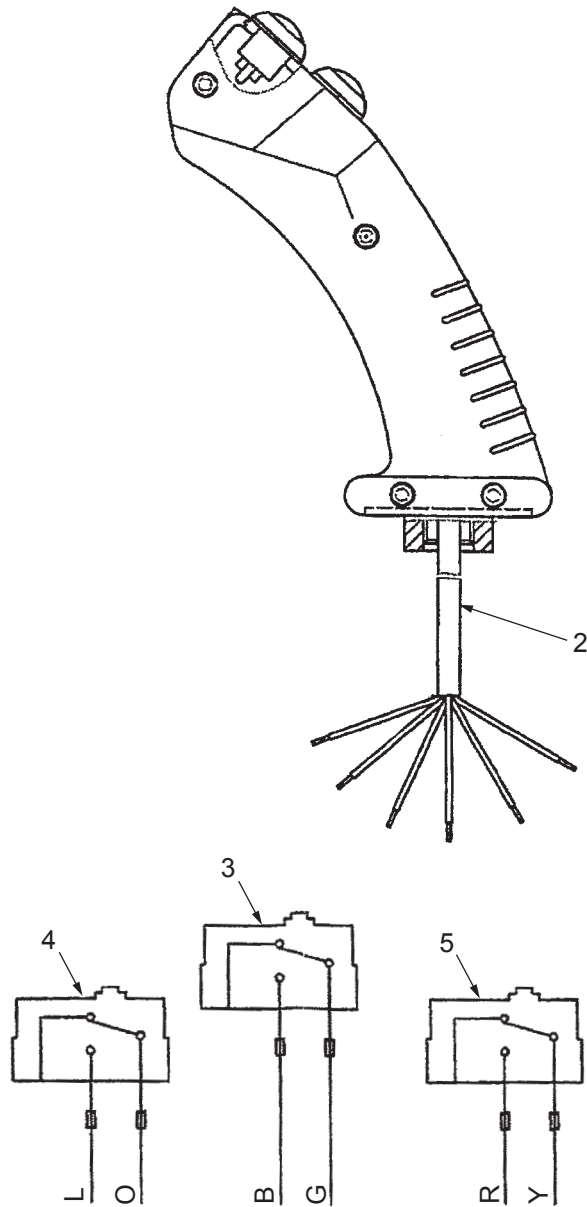

Harness side

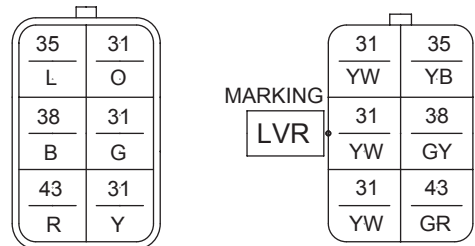

Electrical circuit

Wire color and number
(Refer to "1-4 Wire Color Code and Number" of TROUBLESHOOTING.)

- The arrangement of connector terminals shown below is that of connecting surfaces on the connector side.

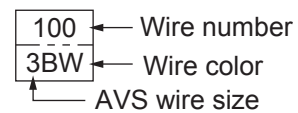

SW880-05012

- (1) Handle shell
- (2) Switch cord assembly
- (3) Automatic speed setting switch (White)
- (4) Vibrator switch (Green)
- (5) Water spray switch (Blue)

② Vibrator motor piping

- Remove the hydraulic hose clamp (31).
- Disconnect the four hydraulic hoses (27), (28), (29) and (30) connecting to the vibrator motor.

(NOTICE)

- **Plug both ends of the disconnected hoses or implement other actions to prevent entry of foreign matter.**

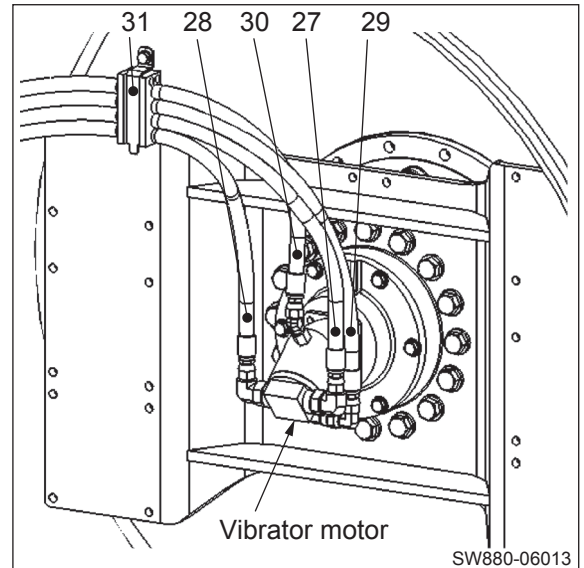

- 13) Lift the drum (32) with a crane and remove the twelve bolts (33) (left and right) taking care not to apply load to the bolts.
- Lift the drum (32) and remove it from the frame.



Weight of drum

SW880 : 3,100 kg (6,834 lbs.)

SW990 : 3,215 kg (7,088 lbs.)

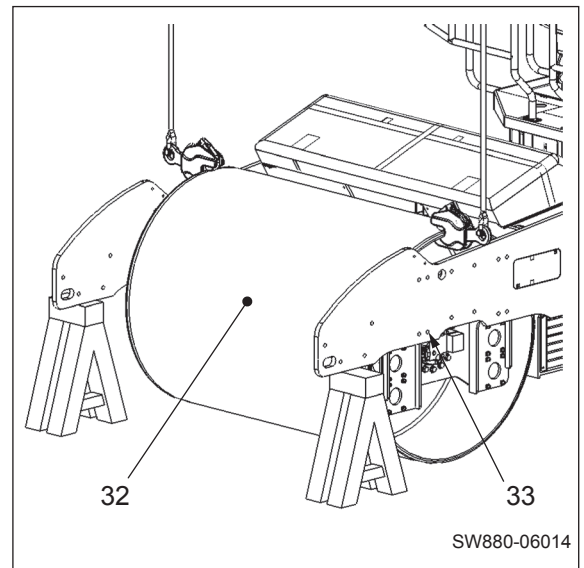

- 14) Place support stands or the like under the vehicle body from which the drum have been removed as shown on the right.

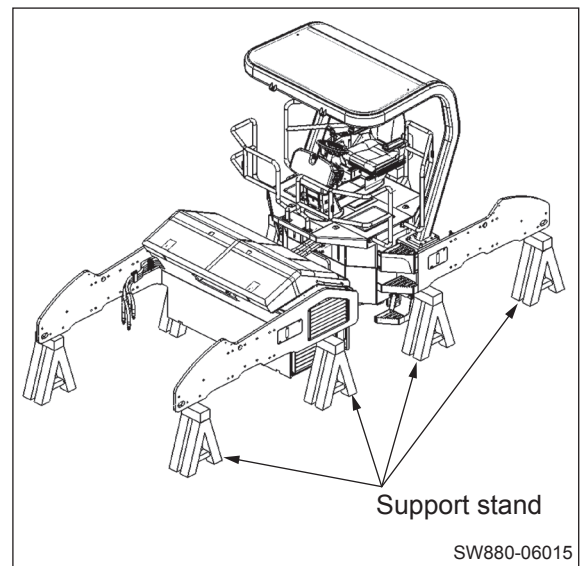

- 7) Using the two pulling bolts (M16×2.0), lift the axle shaft (13).

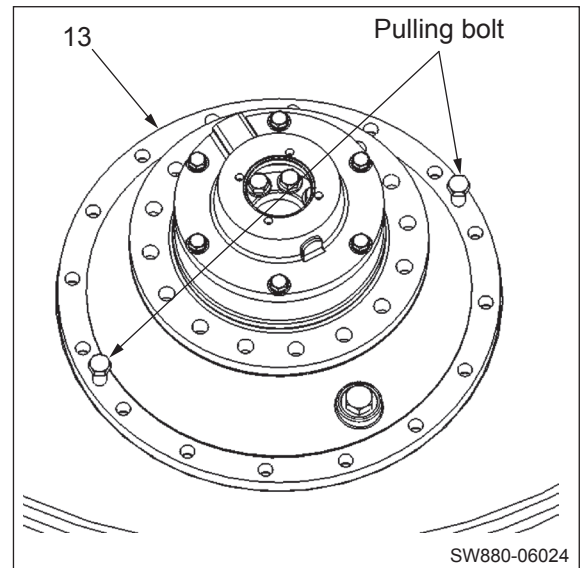

⚠ WARNING

When attaching the lifting bolts, screw in the threads fully before using.

- 8) Install lifting bolts (M16×2.0) on the axle shaft (13).

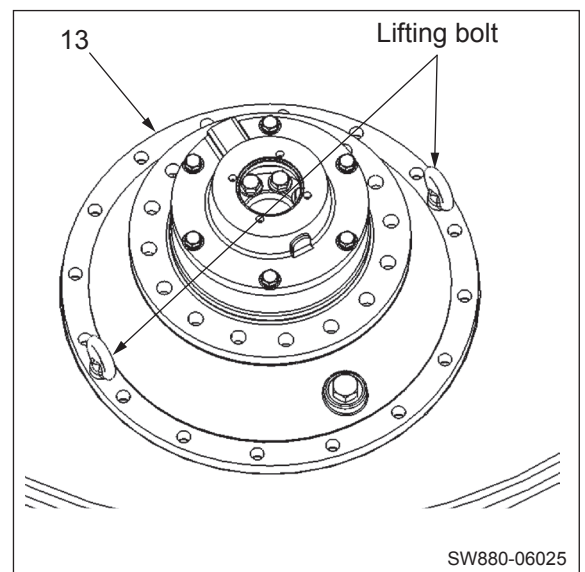

- 9) Slowly lift the axle shaft subassembly with a crane to remove it.

(NOTICE)

- In order not to lift the eccentric shaft together with the axle shaft subassembly, tap on the eccentric shaft end with a wooden hammer via a wooden bar during lifting.

 Axle shaft subassembly : 140 kg (309 lbs.)

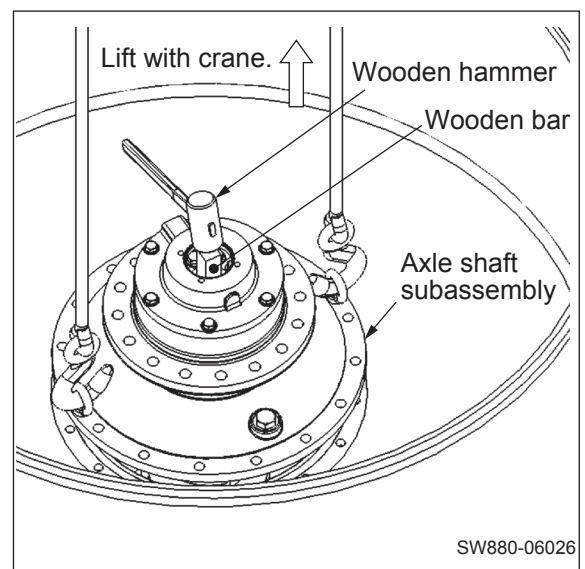

37) Remove the snap ring (43).

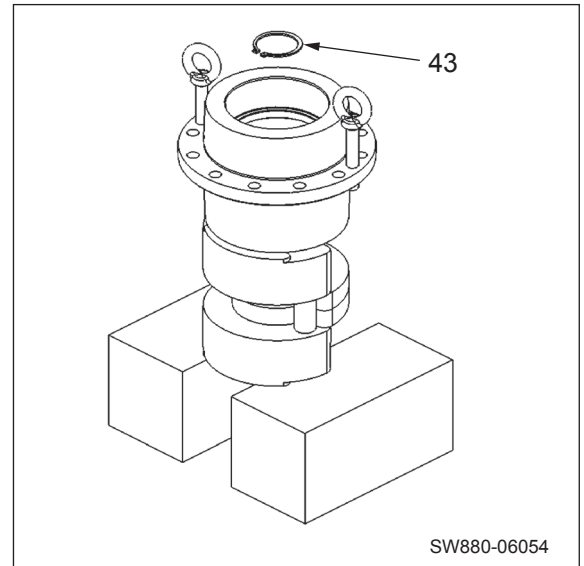

38) Lift the housing (8) with a crane to separate it from the eccentric shaft (4).

 Weight of housing : 40 kg (88 lbs.)

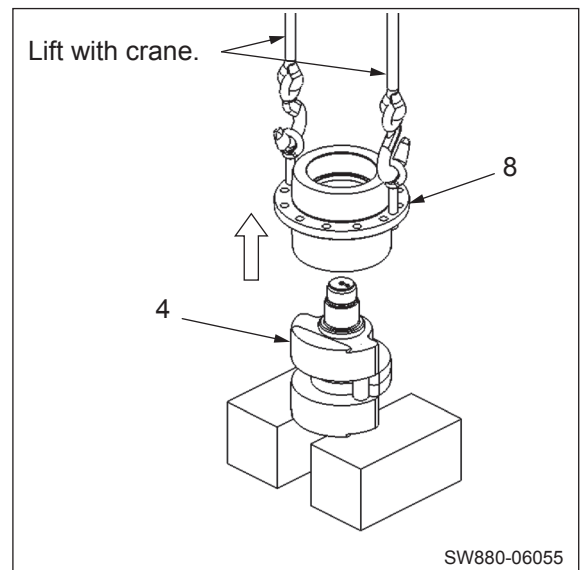

39) Put the housing (8) on wooden blocks.

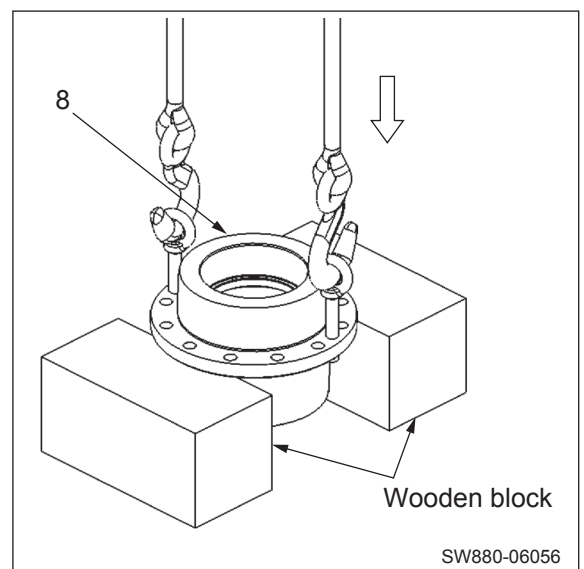

- 13-4) Install the plugs (38) on the axle shaft subassembly.
- Apply sufficient amount of lithium-based grease to the roller surface of the roller bearing (36).

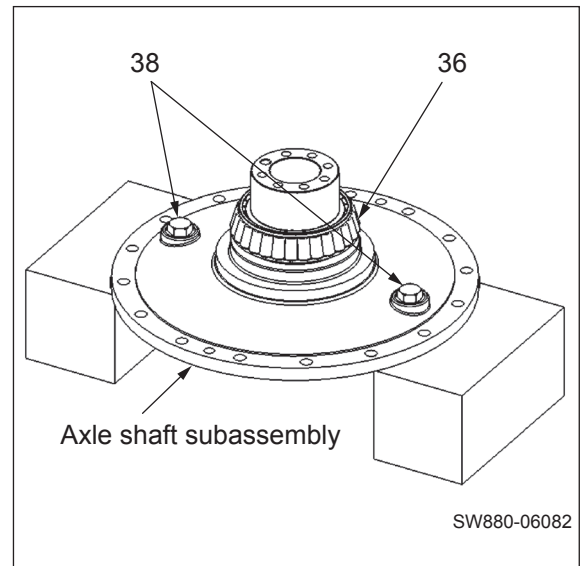

- 13-5) Install lifting bolts (M12×1.75) on the housing subassembly and lift it with a crane to joint it with the axle shaft subassembly.

 Housing subassembly : 50 kg (110 lbs.)

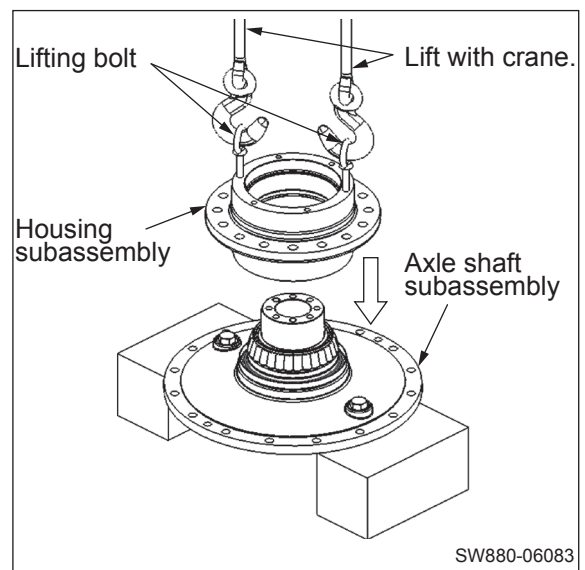

- 13-6) Apply sufficient amount of lithium-based grease to the roller surface of the inner race of the roller bearing (36).
- Drive the roller bearing (36) into the housing subassembly until the roller surface of its inner race comes into contact with the outer race.

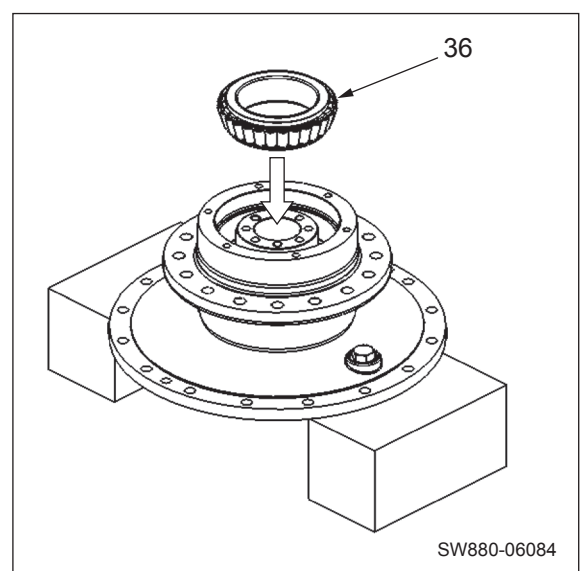

CLICK HERE TO **DOWNLOAD** THE COMPLETE MANUAL

- Thank you very much for reading the preview of the manual.
- You can download the complete manual from: www.heydownloads.com by clicking the link below



- Please note: If there is no response to CLICKING the link, please download this PDF first and then click on it.

CLICK HERE TO **DOWNLOAD** THE COMPLETE MANUAL

(NOTICE)

- When installing the propulsion motor (51), pay attention to the positional relationship with the vibrator motor (27).

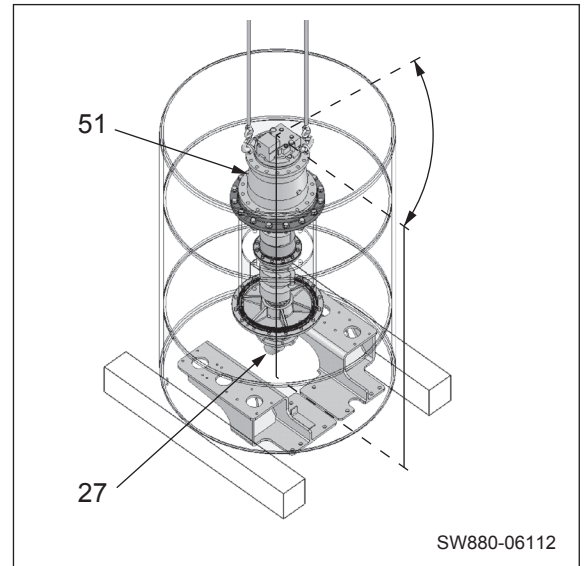

SW880-06112

- 34) Secure the propulsion motor (51) with the bolts (48) and washers.

 (48) M20×60 : 540 N·m (398 lbf·ft)

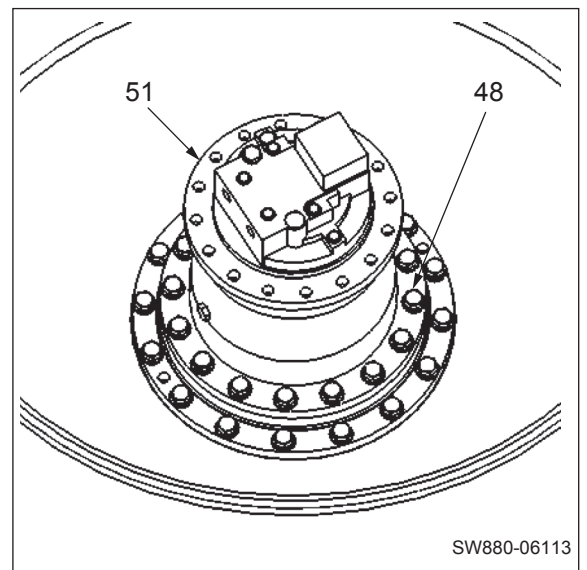

SW880-06113

- 35) Install lifting bolts and nuts (M22×2.5) on a subassembly of the brackets (46) and (54), plate (53) and dampers (57) as shown on the right.

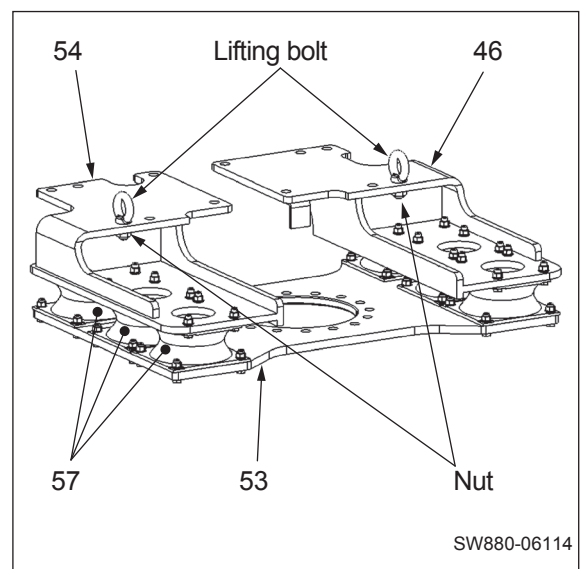

SW880-06114

1. FLOORBOARD

1-1. Operator Station

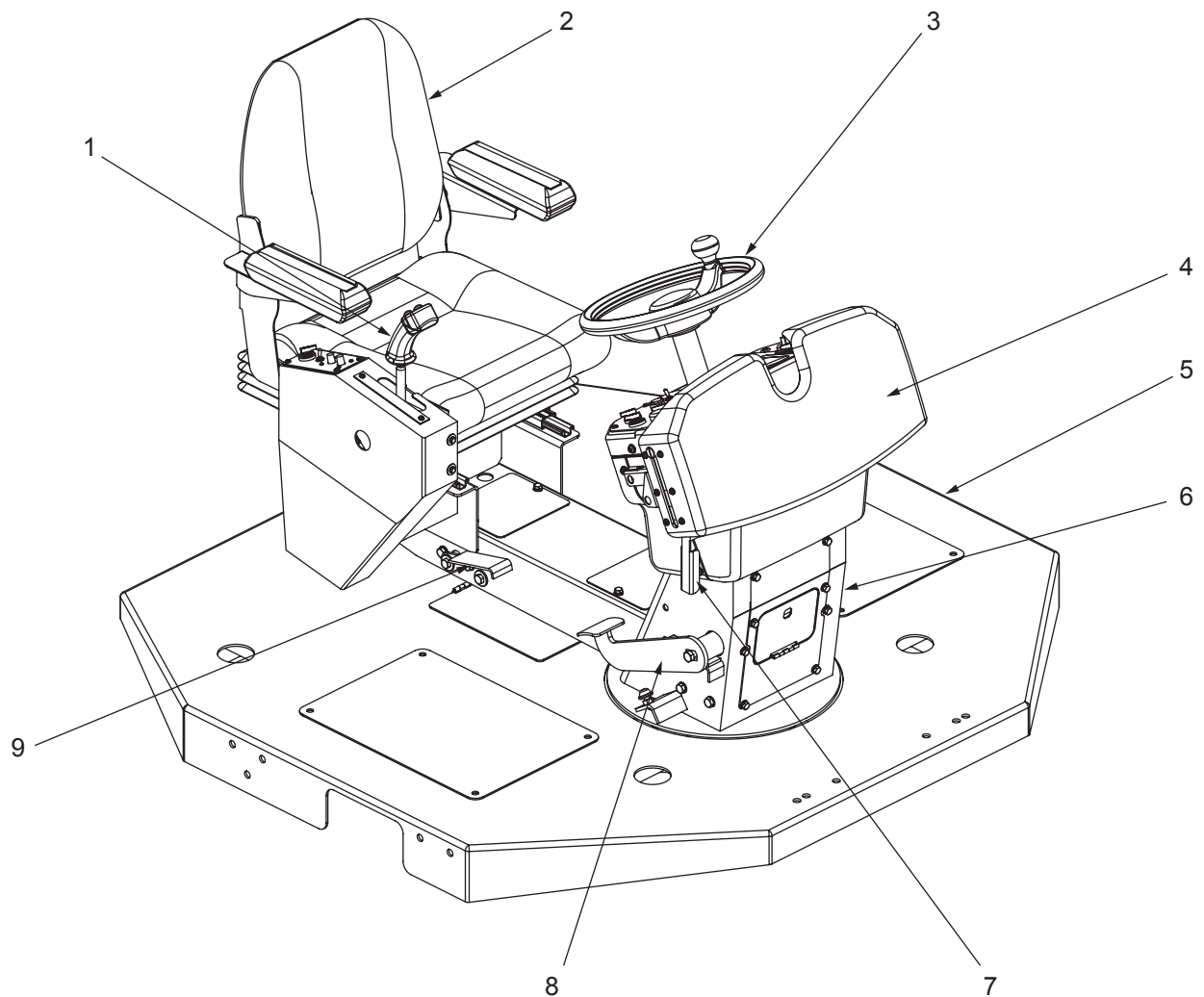

SW880-08001

- (1) Forward-reverse lever
- (2) Seat
- (3) Steering wheel
- (4) Cover
- (5) Floorboard
- (6) Dashboard
- (7) Tilt lock lever
- (8) Brake pedal
- (9) Swivel lock release pedal

INSPECTION AND ADJUSTMENT

5. MEASUREMENT OF PARKING BRAKE RELEASE PRESSURE

5-1. Measurement

- Oil temperature during measurement: $50 \pm 5^{\circ}\text{C}$
($122 \pm 41^{\circ}\text{F}$)
- ① Disconnect the hose (1) or (2) from the brake solenoid valve. Attach the pressure gauge through the adapter (d).
- Adapter (d) : 4-4LOHL6G5TP (Parker part number)
- Pressure gauge: 0 to 4.9 MPa (0 to 711 psi)
- ② Confirm that the forward-reverse level is in the neutral position.
- ③ Press the parking brake switch to set the parking brake to "ON".
- ④ Start the engine and set the engine speed switch to the "FULL" position.
- ⑤ Set the parking brake switch to "OFF" and read the brake release pressure indicated by the pressure gauge.

★ **Standard charge relief pressure setting
(brake release pressure)**

: $2.5 \pm 0.2 \text{ MPa}$ ($362 \pm 29 \text{ psi}$)

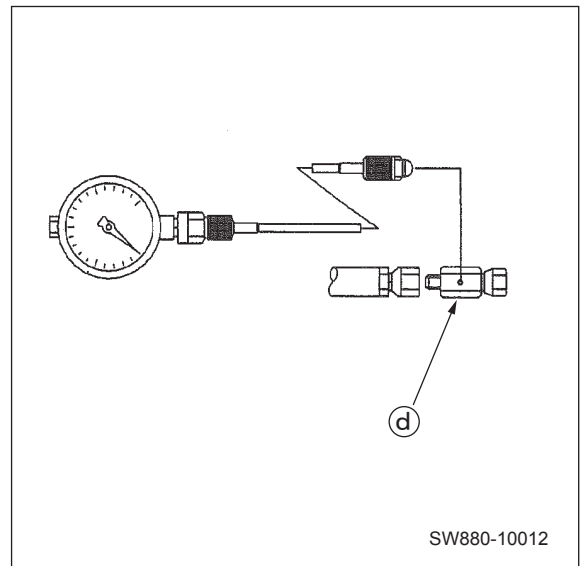
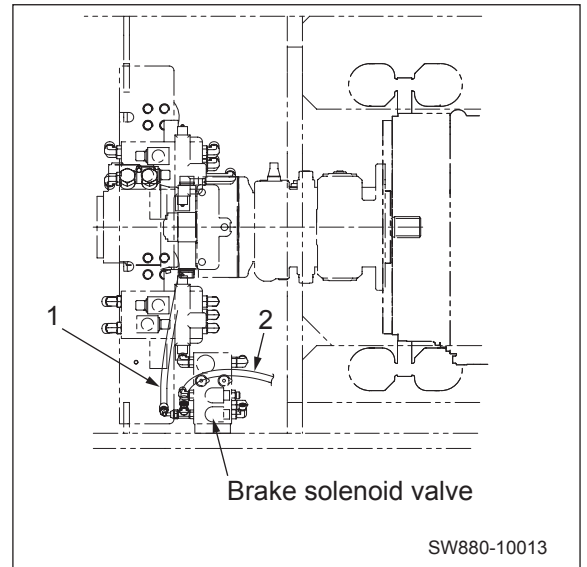

1. TROUBLESHOOTING

1-1. Safety Precautions for Troubleshooting

WARNING

Unexpected vehicle movement may cause a serious accident. When inspecting the machine while the engine is running, always follow the instructions below.

- Park the machine on level, flat ground.
- Apply the parking brake.
- Set chocks in front and behind each drum or tire.
- Make sure that service personnel are given the appropriate information at the appropriate time.
- Make sure that no one can enter any hazardous area.

CAUTION

Do not work on the hydraulic system while the engine is running and the system is hot and under pressure. Do not disconnect hydraulic hoses or fittings until the system has cooled and pressure has been properly relieved.

Before removing any plugs from the pressure measurement ports, always release any residual pressure from the piping and open the cap of the fluid tank to release and pressure.

WARNING

Inadvertent starting the engine may cause a serious accident.

When inspecting the engine, make sure to exchange the appropriate cues and hand signal with the person at the operator station to avoid any accidents.

CAUTION

Before inspecting inside of the engine compartment, always stop the engine.

Contact with the fan, V-belt or exhaust system parts while the engine is running may cause serious injury.

Example of blink code display

Example: Blink code 2-1-4

The lamp lights up 0.4 second twice, 0.8 second once and then 0.4 seconds four times.

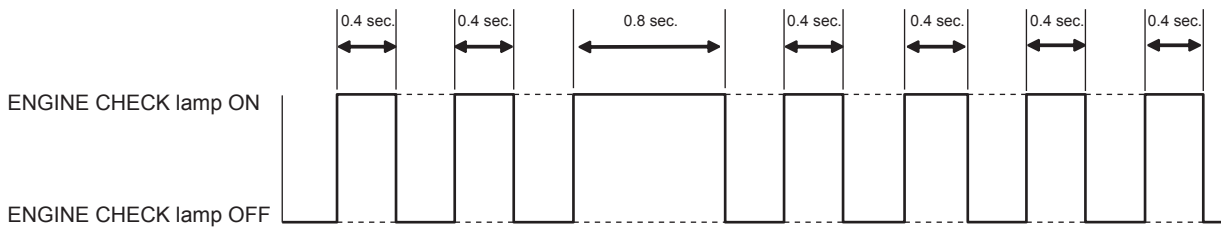

SW880-11008

(NOTICE)

- The SERDIA code can be read by connecting a German-made diagnosis tester to the diagnosis connector. The SERDIA (SERvice DIAGnosis) code allows you to identify the cause of the fault in greater detail than the blink code.

2-2-2. Blink code list

Blink code			SERDIA code	Description
Short (0.4 sec.)	Long (0.8 sec.)	Short (0.4 sec.)		
1	1	1	112	Faulty CAN
1	1	2	113	Faulty CAN
1	1	5	117	Faulty CAN
1	1	6	118	Faulty CAN
1	1	8	120	Faulty CAN
			122	
			124	
			125	
			127	
1	1	9	121	Faulty CAN
			123	
			126	
			128	
1	2	3	54	Faulty coolant temperature warning lamp
1	2	6	138	Faulty hand throttle
1	2	8	149	Defective intake air temperature sensor
1	3	3	136	Temperature sensor 1
			137	
1	3	4	211	Faulty rail pressure
			212	
			213	
			214	
			215	
			216	

2-4-1. Engine will not start (3/8)**Reference Fig. : 2-4-2**

1) When engine check lamp is illuminated or flashing

Blink code	Check point	Check/Cause	Action
5-1-2 or 5-1-5	4. Starter Motor Relay	<p>(1) When the starter switch is ON, measure the voltage between the starter motor relay pin 1 inlet BW wire and the chassis ground. Standard voltage: 12V or more</p> <p>(2) When the starter switch is ON, measure the voltage between the starter motor relay pin 5 inlet Y wire and the chassis ground. Standard voltage: 12V or more</p> <p>(3) When the starter switch is ON, measure the voltage between the starter motor relay pin 3 inlet LB wire and the chassis ground. Standard voltage: 12V or more</p> <p>- If the above items (1) and (2) are OK and the item (3) is NG, the starter motor relay is faulty.</p>	Replace the starter motor relay.
	5. Start Check Relay	<p>(1) When the starter switch is ON, measure the voltage between the start check relay pin 1 BR wire and the chassis ground. Standard voltage: 12V or more</p> <p>(2) When the starter switch is START, measure the voltage between the start check relay pin 3 BY wire and the chassis ground. Standard voltage: 12V or more</p> <p>(3) When the starter switch is START, measure the voltage between the start check relay pin 5 and the chassis ground. Standard voltage: 12V or more</p> <p>- If the above items (1) and (2) are OK and the item (3) is NG, the start check relay is faulty.</p>	Replace the start check relay.
	6. Starter Switch	<p>- Check the continuity between O and O according to the starter switch connection table. The switch is OK if there is continuity between the connections O–O of all the switch positions.</p> <p>- If there is no continuity, the starter switch is faulty.</p>	Replace the starter switch.
	7. EMR 3	- If either the blink code 5-1-2 or 5-1-5 flashes and no abnormality is found in the connector, harness, parking interlock relay, starter motor relay, start check relay and starter switch in the above inspections, the EMR 3 is faulty.	Replace the EMR 3.

2-4-1. Engine will not start (8/8)**Reference Fig. : 2-4-6**

3) Fuel system is abnormal

Check point	Check/Cause	Action
1. Fuel Tank	- Check that the fuel tank is filled with diesel oil. - If the quantity is low, the fuel is not delivered to the fuel system.	Fill the tank with fuel.
	- Check that there is no water that has entered the fuel tank. - If water has entered the tank, the engine does not start.	Drain water from the tank.
	- Check that the quality of the diesel oil is sufficient. - If the oil does not meet the standard, the engine may fail.	Replace the fuel in the tank with an appropriate one.
2. Fuel Prefilter (with sedimenter), Fuel Filter	- Check that the water in the sedimenter is not above the upper limit. - If the amount of water exceeds the limit, the engine does not start.	Drain water.
	- Check the filter for clogging. - Insufficient supply of proper fuel due to clogging of the filter. (NOTICE) • Air bleeding should be performed whenever the filter is replaced.	- Replace the filter. - Bleed the filter.
3. Fuel Supply Pump	- Disconnect the hose connecting to the fuel supply pump and check that fuel flows out of the pump. - If fuel does not flow out of the pump, it is not delivered to the fuel system. (NOTICE) • Air bleeding should be performed whenever the fuel supply pump is replaced.	- Replace the fuel supply pump. - Bleed the pump.
4. Hoses Connecting Between Parts	- Check the hose between the fuel tank and the fuel filter for fuel leakage and clogging. - Hose failure due to deterioration (NOTICE) • Air bleeding should be performed whenever the fuel hose is replaced.	Replace the hose.

2-4-5. Glow plug is not heated (Engine starting performance is bad)**Reference Fig. : 2-4-11**

1) When the engine check lamp is illuminated or flashing.

Blink code	Check point	Check/Cause	Action
2-6-3	1. Connector	- Check the glow plug, switch relay and EMR 3 connector for corrosion, breakage, bending and looseness. - If any abnormality is found, the connector is faulty.	Replace the connector or terminal.
	2. Harness	(1) Measure the resistance between the battery relay terminal R wire and the switch relay terminal R wire. Standard resistance: 10 Ω or less (2) Measure the resistance between the switch relay terminal wire (connected to the glow plug) and each glow plug inlet wire. Standard resistance: 10 Ω or less - If the resistance is abnormal, the harness is faulty.	Repair or replace the harness.
	3. Glow Plug	- When the starter switch is START, measure the voltage between the glow plug inlet terminal and the chassis ground. Standard voltage: 12V or more - If the voltage is normal, the glow plug is faulty.	Replace the glow plug.
	4. Switch Relay or EMR 3	(1) When the starter switch is START, measure the voltage between the switch relay terminal R wire and the chassis ground. Standard voltage: 12V or more (2) When the starter switch is START, measure the voltage between the switch relay terminal (connected to the glow plug) and the chassis ground. Standard voltage: 12V or more - If the above item (1) is OK and the item (2) is NG, the switch relay or EMR 3 is faulty.	Replace the switch relay or EMR 3.

2-5-1. Vehicle moves neither forward nor backward (3/5)





- Check whether the display shows any error code.
- The parking brake switch is OFF (brake OFF).
- The foot brake switch is ON (brake OFF).

Reference Fig. : 2-5-2

1) When the display shows any error code

Error code	Check point	Check/Cause	Action
E 05 or E 06	1. Connector	- Check the back buzzer switch connector and vehicle controller connector (pin 38) for corrosion, breakage, bending and looseness. - If any abnormality is found, the connector is faulty.	Replace the connector or terminal.
	2. Harness	- Measure the resistance between the back buzzer switch connector terminal RY wire and the vehicle controller connector pin 38 RY wire. Standard resistance: 10 Ω or less - If the resistance is abnormal, the harness is faulty.	Repair or replace the harness.
	3. Back Buzzer Switch	(1) When the forward-reverse lever is in the neutral position and the starter switch is OFF, check the continuity between the back buzzer switch COM terminal inlet and the NC terminal. There is no continuity in the normal condition. (2) When the forward-reverse lever is in the forward position and the starter switch is OFF, check the continuity between the back buzzer switch COM terminal inlet and the NC terminal. There is no continuity in the normal condition. (3) When the forward-reverse lever is in the reverse position and the starter switch is OFF, check the continuity between the back buzzer switch COM terminal inlet and the NC terminal. There is continuity in the normal condition. - If any of the items (1), (2) and (3) is NG, the back buzzer switch is faulty.	Replace the back buzzer switch.
	4. Vehicle Controller	- If the error code E 05 or E 06 is displayed and no abnormality is found in the connector, harness and back buzzer switch in the above inspections, the vehicle controller is faulty.	Replace the vehicle controller.

2-5-4. Automatic speed function does not work (1/7)





- Set the speed selector switch to the  position.
(The automatic speed function is disabled when the speed selector switch is in the  position.)
- Check that the speed selector can be switched between the work speed ( position) and the drive speed ( position).
- Set the engine speed switch to the FULL position.
(The automatic speed function is disabled when the engine speed switch is in any other position than the FULL position.)

Reference Fig. : 2-5-5

1) When the display shows any error code

Error code	Check point	Check/Cause	Action
E 11	1. Connector	- Check the speed sensor connector and vehicle controller connector (pins 7, 8 and 9) for corrosion, breakage, bending and looseness. - If any abnormality is found, the connector is faulty.	Replace the connector or terminal.
	2. Harness	- Measure the resistance between the speed sensor connector terminal R, W and B wires and the vehicle controller connector pin 7 R wire, pin 8 W wire and pin 9 B wire. Standard resistance: 10 Ω or less - If the resistance is abnormal, the harness is faulty.	Repair or replace the harness.
	3. Speed Sensor	(1) When the starter switch is ON, measure the voltage between the speed sensor input terminal R wire and the exact meter ground terminal B wire. Standard voltage: 5V (2) Start the engine and rotate the drum. Measure the pulse between the speed sensor terminal W wire and the speed sensor ground terminal B wire with a pulse meter. Standard pulse: 21 pulses/rotation - If the above item (1) is OK and the item (2) is NG, the speed sensor is faulty.	Replace the speed sensor.
	4. Vehicle Controller	- If the error code E 11 is displayed and no abnormality is found in the connector, harness and speed sensor in the above inspections, the vehicle controller is faulty.	Replace the vehicle controller.

2-5-4. Automatic speed function does not work (6/7)

- Set the speed selector switch to the  position.
(The automatic speed function is disabled when the speed selector switch is in the  position.)
- Check that the speed selector can be switched between the work speed ( position) and the drive speed ( position).
- Set the engine speed switch to the FULL position.
(The automatic speed function is disabled when the engine speed switch is in any other position than the FULL position.)

Reference Fig. : 2-5-9

1) When the display shows any error code

Error code	Check point	Check/Cause	Action
E 41	1. Connector	- Check the EMR 3 connector (pins 61 and 62) and vehicle controller connector (pins 16 and 17) for corrosion, breakage, bending and looseness. - If any abnormality is found, the connector is faulty.	Replace the connector or terminal.
	2. Harness	- Measure the resistance between the EMR 3 connector pin 61 RY wire and pin 62 RB wire and the vehicle controller connector pin 16 RB wire and pin 17 RY wire. Standard resistance: 10 Ω or less - If the resistance is abnormal, the harness is faulty. (NOTICE) • Since shielded twisted wires are used for the vehicle controller terminal harness, repair is not approved. Be sure to replace them.	Replace the harness.
	3. CAN Communication	- Faulty CAN communication (NOTICE) • Check if any CAN-related blink code for the engine is issued. If no blink code is issued, the vehicle controller is faulty.	Replace the vehicle controller.

2-6. Vibration

Check the following items before troubleshooting.

- The fuses have not been blown and power is applied up to the fuses.
- When measuring voltage without disconnecting connectors, refer to the description of voltage measurement methods (P.11-006).

2-6-1. No vibration occurs (1/2)

- Check whether the display shows any error code.

Reference Fig. : 2-6-1

1) When the display shows any error code

- Set the vibration mode (continuous/automatic) selector switch to the continuous position.

Error code	Check point	Check/Cause	Action
E 33 or E 34	1. Connector	- Check the vibration forward-reverse lever switch connector and vehicle controller connector (pin 6) for corrosion, breakage, bending and looseness. - If any abnormality is found, the connector is faulty.	Replace the connector or terminal.
	2. Harness	(1) Measure the resistance between the vibration forward-reverse lever switch connector terminal YB wire and the vehicle controller connector pin 6 YB wire. Standard resistance: 10 Ω or less (2) Measure the resistance between the vibration forward-reverse lever switch connector terminal YW wire and the fuse box 8 input YW wire. Standard resistance: 10 Ω or less - If the resistance is abnormal, the harness is faulty.	Repair or replace the harness.
	3. Vibration Proportional Magnetic Valve Solenoid L or H	- Disconnect the harness of the vibration proportional magnetic valve solenoid L or H and measure the resistance of the coil. Standard resistance: 5.5 Ω - If the resistance is abnormal, the corresponding vibration proportional magnetic valve solenoid L or H is faulty.	Replace the vibration proportional magnetic valve solenoid L or H.
	4. Vehicle Controller	(1) When the starter switch is ON, measure the voltage between the vehicle controller input power supply pins 30, 31 and 32 and the ground pins 33, 34 and 44. Standard voltage: 12V or more (2) When the starter switch is ON, measure the voltage between the vehicle controller pin 6 (positive side) and the pin 58 (negative side) with the green button on the vibration forward-reverse lever switch pressed. Standard voltage: 12V - If the above items (1) and (2) are OK, the vehicle controller is faulty.	Replace the vehicle controller.

2-6-4. Continuous/automatic-vibration mode cannot be switched

Reference Fig. : 2-6-5

Check point	Check/Cause	Action
1. Vibration Mode (Continuous/Automatic) Selector Switch	<p>(1) When the starter switch is ON and the vibration mode (continuous/automatic) selector switch is set to the continuous position, measure the voltage between the vibration mode (continuous/automatic) selector switch pins 1 and 4 YW wires and the chassis ground. Standard voltage: 12V</p> <p>(2) When the starter switch is ON and the vibration mode (continuous/automatic) selector switch is set to the continuous position, measure the voltage between the vibration mode (continuous/automatic) selector switch pin 3 GB wire and pin 5 YL wire and the chassis ground. There is no current in the normal condition.</p> <p>(3) When the starter switch is ON and the vibration mode (continuous/automatic) selector switch is set to the automatic position, measure the voltage between the vibration mode (continuous/automatic) selector switch pin 3 GB wire and pin 5 YL wire and the chassis ground. Standard voltage: 12V</p> <p>- If the above item (1) is OK and the item (2) or (3) is NG, the vibration mode (continuous/automatic) selector switch is faulty.</p>	Replace the vibration mode (continuous/automatic) selector switch.
2. Resistor Unit	<p>- Measure the resistance between the resistor unit terminal inlet GB wire 36 and YL wire 37 and the B wire 44. Standard resistance: 300 Ω</p> <p>- If the resistance is abnormal, the resistor unit is faulty.</p> <p>(NOTICE)</p> <ul style="list-style-type: none"> • The resistor unit is used to stabilize the contact of the switch. 	Replace the resistor unit.
3. Vehicle Controller	<p>(1) When the starter switch is ON, measure the voltage between the vehicle controller input power supply pins 30, 31 and 32 and the ground pins 33, 34 and 44. Standard voltage: 12V or more</p> <p>(2) When the starter switch is ON and the vibration mode (continuous/automatic) selector switch is in the continuous position, measure the voltage between the vehicle controller pin 2 GB wire and pin 48 YL wire and the pin 58 B wire. There is no current in the normal condition.</p> <p>(3) When the starter switch is ON and the vibration mode (continuous/automatic) selector switch is in the automatic position, measure the voltage between the vehicle controller pin 2 GB wire and pin 48 YL wire and the pin 58 B wire. Standard voltage: 12V or more</p> <p>- If the above item (1) is OK and the item (2) or (3) is NG, the vehicle controller is faulty.</p>	Replace the vehicle controller.
4. Harness Connecting Between Terminals	<p>- Measure the resistance of the harness connecting between terminals. Standard resistance: 10 Ω or less</p> <p>- If the resistance is abnormal, the harness is faulty.</p>	Repair or replace the harness.

2-8. Water Spray

Check the following item before troubleshooting.

- No fuse has been blown.

2-8-1. Continuous water spray cannot be performed (1/4)

- Set the water spray mode (continuous/automatic) selector switch to the continuous position.
- Set the timer switch to the OFF position.
- Set the water spray pump switch to the simultaneous spray position.

Reference Fig. : 2-8-1

Check point	Check/Cause	Action
1. Battery Capacity	<ul style="list-style-type: none"> - Measure the battery voltage or specific gravity. Standard voltage: 12V or more Standard specific gravity: 1.26 or more - If the measured value is below the standard, the battery capacity is insufficient. 	Charge or replace the battery.
2. Water Spray Pump	<p>(1) When the starter switch is ON and the blue button on the water spray forward-reverse lever switch is pressed once, measure the voltage between each water spray pump's inlet G, GW, L and LW wires and the chassis ground. Standard voltage: 12V or more</p> <p>(2) Check if the grounding of each water spray pump is normal.</p> <ul style="list-style-type: none"> - If the above items (1) and (2) are OK and the water spray pump does not operate, the water spray pump is faulty. <p>(NOTICE)</p> <ul style="list-style-type: none"> • There are a total of four water spray pumps, two each for the front and rear drums. - Pressing the blue button on the water spray forward-reverse lever switch turns on the power and the power is turned off when the switch is pressed again. 	Replace the water spray pump.
3. Water Spray Forward-Reverse Lever Switch	<ul style="list-style-type: none"> - Measure the resistance between the water spray forward-reverse lever switch COM terminal YW wire and the NO terminal GR wire with the blue button on the water spray forward-reverse lever switch pressed. Standard resistance: 10 Ω or less - If the resistance is abnormal, the water spray forward-reverse lever switch is faulty. <p>(NOTICE)</p> <ul style="list-style-type: none"> • Pressing the blue button on the water spray forward-reverse lever switch turns on the power and the power is turned off when the switch is pressed again. 	Replace the water spray forward-reverse lever switch.
4. Water Spray (Continuous/Automatic) Selector Switch	<p>(1) When the starter switch is ON and the blue button on the water spray forward-reverse lever switch is pressed once, measure the voltage between the water spray mode (continuous/automatic) selector switch pin 1 inlet GW wire and the chassis ground. Standard voltage: 12V</p> <p>(2) When the starter switch is ON and the blue button on the water spray forward-reverse lever switch is pressed once, measure the voltage between the water spray mode (continuous/automatic) selector switch pin 2 inlet GL wire and the chassis ground. Standard voltage: 12V</p> <ul style="list-style-type: none"> - If the above item (1) is OK and the item (2) is NG, the water spray mode (continuous/automatic) selector switch is faulty. 	Replace the water spray mode (continuous/automatic) selector switch.

2-8-3. Continuous water spray works, but automatic water spray cannot be performed

- Set the water spray mode (continuous/automatic) selector switch to the automatic position.
- Set the timer switch to the OFF position.
- Set the water spray pump switch to the simultaneous spray position.

Reference Fig. : 2-8-4

Check point	Check/Cause	Action
1. Forward-Reverse Lever Switch	<p>(1) When the forward-reverse lever switch is in the neutral position and the starter switch is OFF, check the continuity between the forward-reverse lever switch COM terminal inlet and the NC terminal. There is continuity in the normal condition.</p> <p>(2) When the forward-reverse lever switch is in the forward or reverse position and the starter switch is OFF, check the continuity between the forward-reverse lever switch COM terminal inlet and the NO terminal. There is continuity in the normal condition.</p> <p>- If the above item (1) or (2) is NG, the forward-reverse lever switch is faulty.</p>	Replace the forward-reverse lever switch.
2. Water Spray Mode (Continuous/Automatic) Selector Switch	<p>(1) When the forward-reverse lever switch is in the forward or reverse position and the starter switch is ON, measure the voltage between the water spray mode (continuous/automatic) selector switch pin 4 inlet O wire and the chassis ground. Standard voltage: 12V</p> <p>(2) When the forward-reverse lever switch is in the forward or reverse position and the starter switch is ON, measure the voltage between the water spray mode (continuous/automatic) selector switch pin 5 GL wire and the chassis ground. Standard voltage: 12V</p> <p>- If the above item (1) is OK and the item (2) is NG, the water spray mode (continuous/automatic) selector switch is faulty.</p>	Replace the water spray mode (continuous/automatic) selector switch.
3. Harness Connecting Between Terminals	<p>- Measure the resistance of the harness connecting between terminals. Standard resistance: 10 Ω or less</p> <p>- If the resistance is abnormal, the harness is faulty.</p>	Repair or replace the harness.

2-9-6. Temperature gauge is abnormal

Reference Fig. : 2-9-4

Check point	Check/Cause	Action
1. Thermo Unit	<ul style="list-style-type: none"> - Disconnect the harness and measure the resistance of the thermo unit. Standard resistance: 153.9 Ω [(at unit temperature of 50°C (122°F)) 27.4 Ω [(at unit temperature of 100°C (212°F)) - If the resistance is abnormal, the thermo unit is faulty. 	Replace the thermo unit.
2. Resistor Unit	<ul style="list-style-type: none"> - Measure the resistance between the resistor unit terminal inlet G wire and the outlet terminal Sb wire. Standard resistance: 1 Ω - If the resistance is abnormal, the resistor unit is faulty. <p>(NOTICE)</p> <ul style="list-style-type: none"> • Check that the resistance of the resistor unit R4 is normal. 	Replace the resistor unit.
3. Combination Meter	<ul style="list-style-type: none"> - When the starter switch is ON, measure the voltage between the combination meter terminal R wire (battery terminal) and P wire (starter switch terminal) and the ground terminal B wire. Standard voltage: 12V or more - If the above item is OK and no abnormality is found in the thermo unit and resistor unit, the combination meter is faulty. 	Replace the combination meter.
4. Harness Connecting Between Terminals	<ul style="list-style-type: none"> - Measure the resistance of the harness connecting between terminals. Standard resistance: 10 Ω or less - If the resistance is abnormal, the harness is faulty. 	Repair or replace the harness.

2-9-13. Working lamp indicator lamp does not light

- Check that the headlamps and working lamps can be turned on.

Reference Fig. : 2-9-9

Check point	Check/Cause	Action
1. Harness	<ul style="list-style-type: none"> - Measure the resistance between the lighting switch pin 5 inlet RL wire and the combination meter connector pin RL wire 5. Standard resistance: 10 Ω or less - If the resistance is abnormal, the harness is faulty. 	Repair or replace the harness.
2. Combination Meter	<ul style="list-style-type: none"> (1) When the starter switch is ON, measure the voltage between the combination meter terminal R wire (battery terminal) and P wire (starter switch terminal) and the ground terminal B wire. Standard voltage: 12V or more (2) When the starter switch is turned ON and the second stage of the lighting switch is also turned ON, measure the voltage between the combination meter terminal LW wire (working lamp terminal) and the chassis ground. Standard voltage: 12V or more - If the above items (1) and (2) are OK, the combination meter is faulty. 	Replace the combination meter.

2-9-14. Parking brake indicator lamp does not light

Reference Fig. : 2-9-10

Check point	Check/Cause	Action
1. Harness	<ul style="list-style-type: none"> - Measure the resistance between the parking brake switch pin 4 inlet L wire and the combination meter connector pin L wire 18. Standard resistance: 10 Ω or less - If the resistance is abnormal, the harness is faulty. 	Repair or replace the harness.
2. Parking Brake Switch	<ul style="list-style-type: none"> - When the parking brake is turned ON, check the continuity between the parking brake switch pins 4 and 5. There is continuity in the normal condition. - If there is no continuity, the parking brake switch is faulty. 	Replace the parking brake switch.
3. Combination Meter	<ul style="list-style-type: none"> (1) When the starter switch is ON, measure the voltage between the combination meter terminal R wire (battery terminal) and P wire (starter switch terminal) and the ground terminal B wire. Standard voltage: 12V or more (2) When the starter switch is ON, measure the voltage between the combination meter terminal GR wire (parking brake terminal) and the chassis ground. Standard voltage: 12V or more - If the above item (1) is OK and the item (2) is NG, the combination meter is faulty. 	Replace the combination meter.

CLICK HERE TO **DOWNLOAD** THE COMPLETE MANUAL

- Thank you very much for reading the preview of the manual.
- You can download the complete manual from: www.heydownloads.com by clicking the link below



- Please note: If there is no response to CLICKING the link, please download this PDF first and then click on it.

CLICK HERE TO **DOWNLOAD** THE COMPLETE MANUAL