

Service
Service
Service



L_17901_000.eps
260808

Service Manual

Contents	Page	
1. Technical Specifications, Connections, and Chassis Overview	2	
2. Safety Instructions, Warnings, and Notes	6	
3. Directions for Use	7	
4. Mechanical Instructions	8	
5. Service Modes, Error Codes, and Fault Finding	15	
6. <i>Block Diagrams, Test Point Overview, and Waveforms</i>		
Wiring Diagram 42" (VE8 LED BL)	47	
Wiring Diagram 37" (Styling Aurea VE8)	48	
Wiring Diagram 42" (Styling Aurea VE8)	49	
Block Diagram Video	50	
Block Diagram Audio	51	
Block Diagram Control & Clock Signals	52	
SSB: Test Points (Overview Top Side)	53	
I2C IC Overview	63	
Supply Lines Overview	64	
7. <i>Circuit Diagrams and PWB Layouts</i>		<i>Drawing PWB</i>
Main Power Supply IPB 37" Stby, MF	(A1) 65	68-69
Main Power Supply IPB 37": HV Inverter	(A2) 66	68-69
Main Power Supply IPB 37": DC / DC	(A3) 67	68-69
LED DIM Panel: DC / DC	(AB1) 70	79-80
LED DIM Panel: Video Flow - LVDS In	(AB2) 71	79-80
LED DIM Panel: Video Flow - LVDS In	(AB3) 72	79-80
LED DIM Panel: FPGA: Power & Control	(AB4) 73	79-80
LED DIM Panel: Clock	(AB5) 74	79-80
LED DIM Panel: FPGA: Led Dimming 1	(AB6) 75	79-80
LED DIM Panel: FPGA: Led Dimming 2	(AB7) 76	79-80
LED DIM Panel: Display Interfacing	(AB8) 77	79-80
LED DIM Panel: SD RAM	(AB9) 78	79-80
4 LED OSRAM: LED Drive	(AL1) 81	84
4 LED OSRAM: DC / DC	(AL2) 82	84
4 LED OSRAM: Micro Controller Block	(AL3) 83	84
6 LED OSRAM: LED Drive	(AL1) 85	88

Contents	Page	
8 LED Lite-On Panel: DC / DC	(AL2) 86	88
6 LED OSRAM: Micro Controller Block	(AL3) 87	88
8 LED Lite-On Panel: LED Drive	(AL1) 89	93
8 LED Lite-On Panel: DC / DC	(AL2) 90	93
8 LED Lite-On Panel: uC Block	(AL3) 91	93
8 LED Lite-On Panel: LED Drive	(AL4) 92	93
SSB	(B01-B10) 94-146	151-160
SSB: SRP List Explanation		147
SSB: SRP List Part 1		148
SSB: SRP List Part 2		149
SSB: SRP List Part 3		150
AmbiLight Interface Panel	(FA) 161	161
Fan Control	(FC1) 162	163
Mains LED Top Panel	(J) 164	165
Mains LED 2k8 (VE8)	(J) 166	167
Light Spill Panel	(L) 168	169
Temp Sensor Panel	(TS1) 170	171
8. Alignments		173
9. Circuit Descriptions, Abbreviation List, and IC Data Sheets		176
Abbreviation List		188
IC Data Sheets		191
10. Spare Parts List & CTN Overview		205
11. Revision List		205

©Copyright 2008 Koninklijke Philips Electronics N.V.
All rights reserved. No part of this publication may be reproduced, stored in a retrieval system or transmitted, in any form or by any means, electronic, mechanical, photocopying, or otherwise without the prior permission of Philips.



CLICK HERE TO **DOWNLOAD** THE COMPLETE MANUAL

- Thank you very much for reading the preview of the manual.
- You can download the complete manual from: www.heydownloads.com by clicking the link below



- Please note: If there is no response to CLICKING the link, please download this PDF first and then click on it.

CLICK HERE TO **DOWNLOAD** THE COMPLETE MANUAL

4.3.11 IR & LED Board

1. Remove screw and lift the IR & LED Board from the front cover.
 2. Release the cables from the cable clamps.
 3. Unplug the connectors.
- When defective, replace the whole unit.

4.3.12 Lightguide

Refer to next figure for details.

1. Do all steps up to and including step 5 as described in the removal of the LCD Panel.
2. Release the cables from the cable clamps [1].
3. Remove the screws [2] and lift the light guide from the front cover.
4. Remove the unit from the front cover.

When defective, replace the whole unit.



L_17900_007.epi
08070i

Figure 4-6 IR & LED Board

Constraints taken into account:

- Display may only be started when valid LVDS output clock can be delivered by the AVC .
- Between 5 and 50 ms after power is supplied, display should receive valid lvds clock .
- minimum wait time to switch on the lamp after power up is 200ms.

action holder: AVC

action holder: St-by

autonomous action

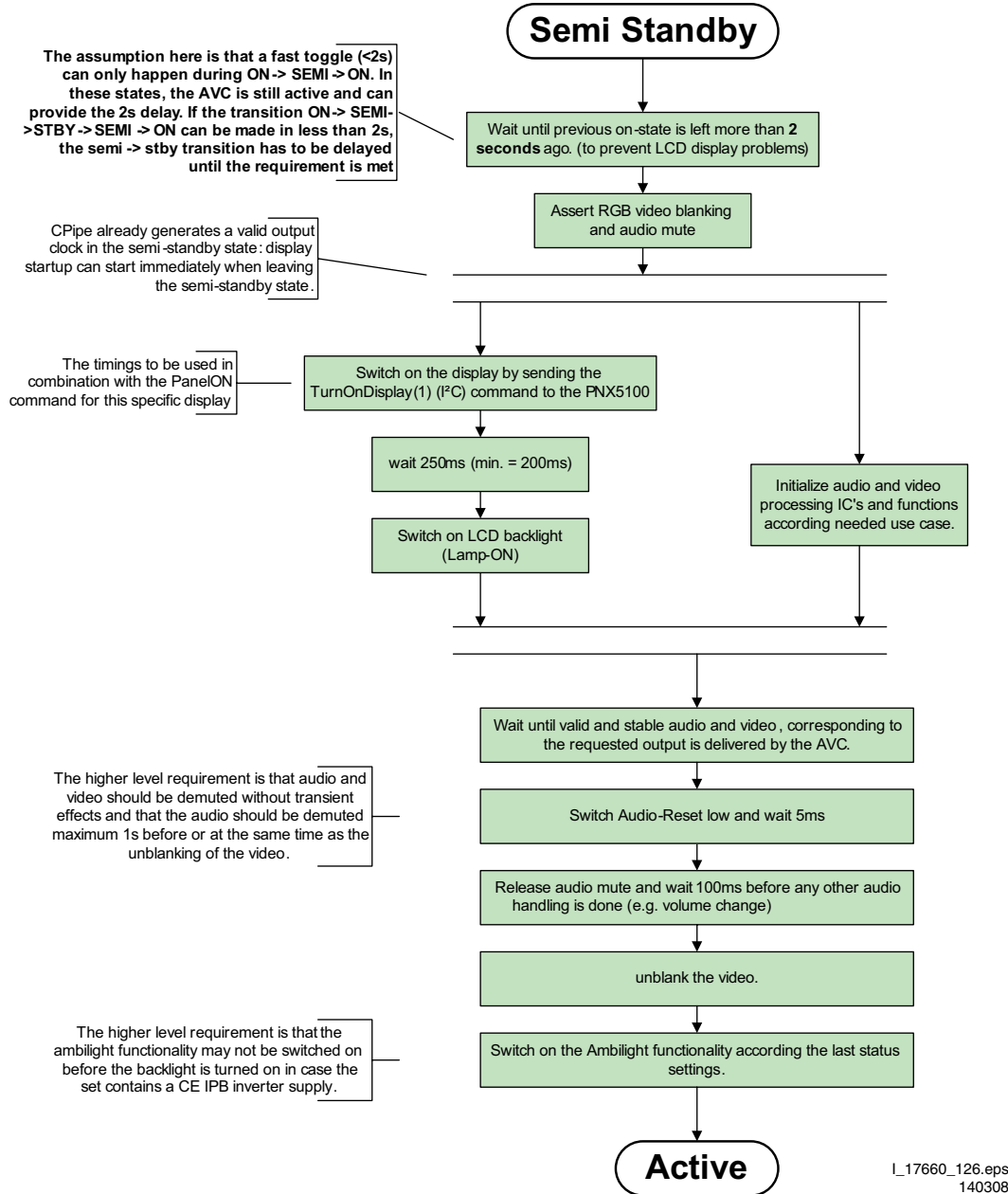

L_17660_126.eps
140308

Figure 5-6 “Semi Stand-by” to “Active” flowchart

before activating via SDM. **In case one of the speakers is not connected, the protection can also be triggered.**

Repair Tips

- It is also possible that the set has an audio DC protection because of an interruption in one or both speakers (the DC voltage that is still on the circuit cannot disappear through the speakers). **Caution:** (Dis)connecting the speakers during the ON state of the TV can damage the audio amplifier.

5.7.3 Important remark regarding the blinking LED indication

As for the blinking LED indication, the blinking led of error layer 1 displaying can be switched off by pushing the power button on the keyboard.

This condition is not valid after the set was unpowered (via mains interruption). The blinking LED starts again and can only be switched off by unplugging the mains connection.

This can be explained by the fact that the MIPS can not load the keyboard functionality from software during the start-up and doesn't recognize the keyboard commands at this time.

5.8 Fault Finding and Repair Tips

Read also section "5.5 Error Codes, 5.5.4 Error Buffer, Extra Info".

Caution: For the whole platform the speaker connections are grounded on -12 V level. During service measurements with earth grounded equipment like e.g. scope, great risk of using the speaker terminal connections for earth ground is currently present. One will short circuit the -12 V to earth ground in that way and will cause damage of the supply/audio part!

5.8.1 Ambilight

Due to degeneration process of the AmbiLights, there can be a difference in the colour and/or light output of the spare ambilight module in comparison with the originals ones contained in the TV set. Via ComPair the light output can be adjusted.

5.8.2 Audio Amplifier

The Class D-IC 7D10 has a powerpad for cooling. When the IC is replaced it must be ensured that the powerpad is very well pushed to the PCB while the solder is still liquid. This is needed to insure that the cooling is guaranteed, otherwise the Class D-IC could break down in short time.

5.8.3 CSM

When CSM is activated and there is a USB stick connected to the TV, the software will dump the complete CSM content to the USB stick. The file (Csm.txt) will be saved in the root of the USB stick. If this mechanism works it can be concluded that a large part of the operating system is already working (MIPS, USB...)

5.8.4 DC/DC Converter

Introduction

The onboard supply consists of 5 DC/DC converters and 7 linear stabilizers. The DC/DC converters have all +12V input voltage and deliver:

- +1V2-PNX8541 supply voltage, stabilized close to PNX8541 chip.
- +1V2-PNX5100 supply voltage, stabilized close to PNX5100 chip.

- +3V3 (overall 3.3 V for onboard ICs).
- +5V for USB and Conditional Access Interface and +5V5-TUN tuner stabilizer.
- +33VTUN for analog only tuners (**AP diversity**).

The linear stabilizers are providing:

- +1V supply voltage (out of +1V2-PNX8541), stabilized close to ST7101 chip (**MPEG4 diversity**).
- +1V8-PNX5100.
- +1V8-PNX8541 (**reserved** because +1V8-PNX5100 used also for DDR2 interface of PNX8541 via 5FB0).
- +2V5 (**MPEG4 diversity**).
- +1V2-STANDBY (out of +3V3-STANDBY).
- +5V-TUN (out of +5V5-TUN).
- +3V3-STANDBY (out of +12V, **reserved**).

+3V3-STANDBY and +1V2-STANDBY are permanent voltages. Supply voltages +1V2-PNX8541, +1V2-PNX5100 and +1V are started immediately when +12V incoming voltage is available (+12V is enabled by STANDBY signal, active low). Supply voltages +3V3, 2V5, +1V8-PNX5100, +1V8-PNX8541, +5V and +5V-TUN are switched-on directly by signal ENABLE-3V3 (active low) when +12V and previous mentioned voltages are all available.

Debugging

The best way to find a failure in the DC/DC converters is to check their starting-up sequence at power-on via the mains cord, presuming that the standby microprocessor and the external supply are operational. Take STANDBY signal high-to-low transition as reference.

When +12V rises above 10V then +1V2-PNX8541, +1V2-PNX5100 and +1V are started immediately. Then, after ENABLE-3V3 goes low, all the other supply voltages should rise within 10 ms. Boost voltages should be OK when +1V2-PNX8541, +1V2-PNX5100 are available (FU07 and FU8A, around 19V).

SUPPLY-FAULT signal should be high when all supply voltages are started-up.

Tips

- Usually, when supply voltage is short-circuited to GND, the corresponding DC/DC converter is making audible noise.
- The drop voltage across resistors 3U70 and 3U3T is 100 mV to 2000 mV.
- Defective (in short-circuit) power MOS-FETs lead usually to their controller IC broken; if one or more high-side MOS-FETs (7U05, 7U08, 7U0D-1 or 7U0H-1) is broken then the platform can be heavily damaged if started in SDM-mode (SUPPLY-FAULT signal is then ignored, while higher than normal supplies will be generated).
- The +33VTUN generator circuit (7U0P + 7U0Q + surrounding components) has low output current capability. In case of too low or no output voltage check transistor 7U0P (gate voltage pulses of about 10 V amplitude and drain voltage pulses of about 35 V amplitude) and the load (not more than 4.5 mA).
- High output ripple voltage of DC/DC converters can be caused by defective (cracked or bad soldered) ceramic capacitors in the feedback (DC or AC) input or output filtering.

5.8.5 Exit "Factory Mode"

When an "F" is displayed in the screen's right corner, this means the set is in "Factory" mode, and it normally happens after a new SSB is mounted. To exit this mode, push the "VOLUME minus" button on the TV's local keyboard for 10 seconds (this disables the continuous mode). Push now the "MENU" button for 10 seconds until the "F" disappears from the screen.



I_17662_004d.eps
110608

Figure 5-21 Example UART log during SWUPG start-up (Normal start-up) part 4.

SSB: Test Points (Part 3 Bottom Side)

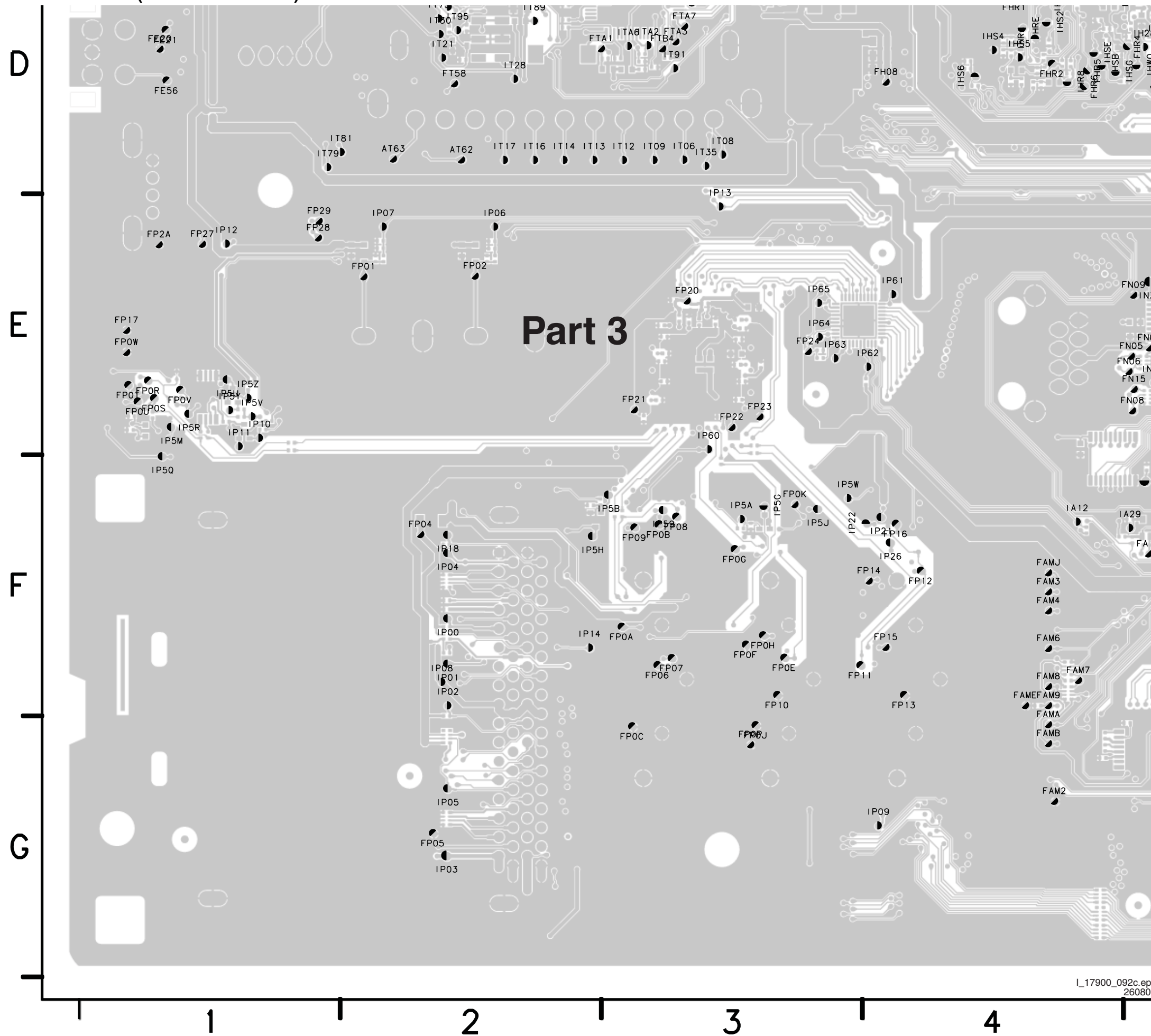

4 LED OSRAM: LED Drive

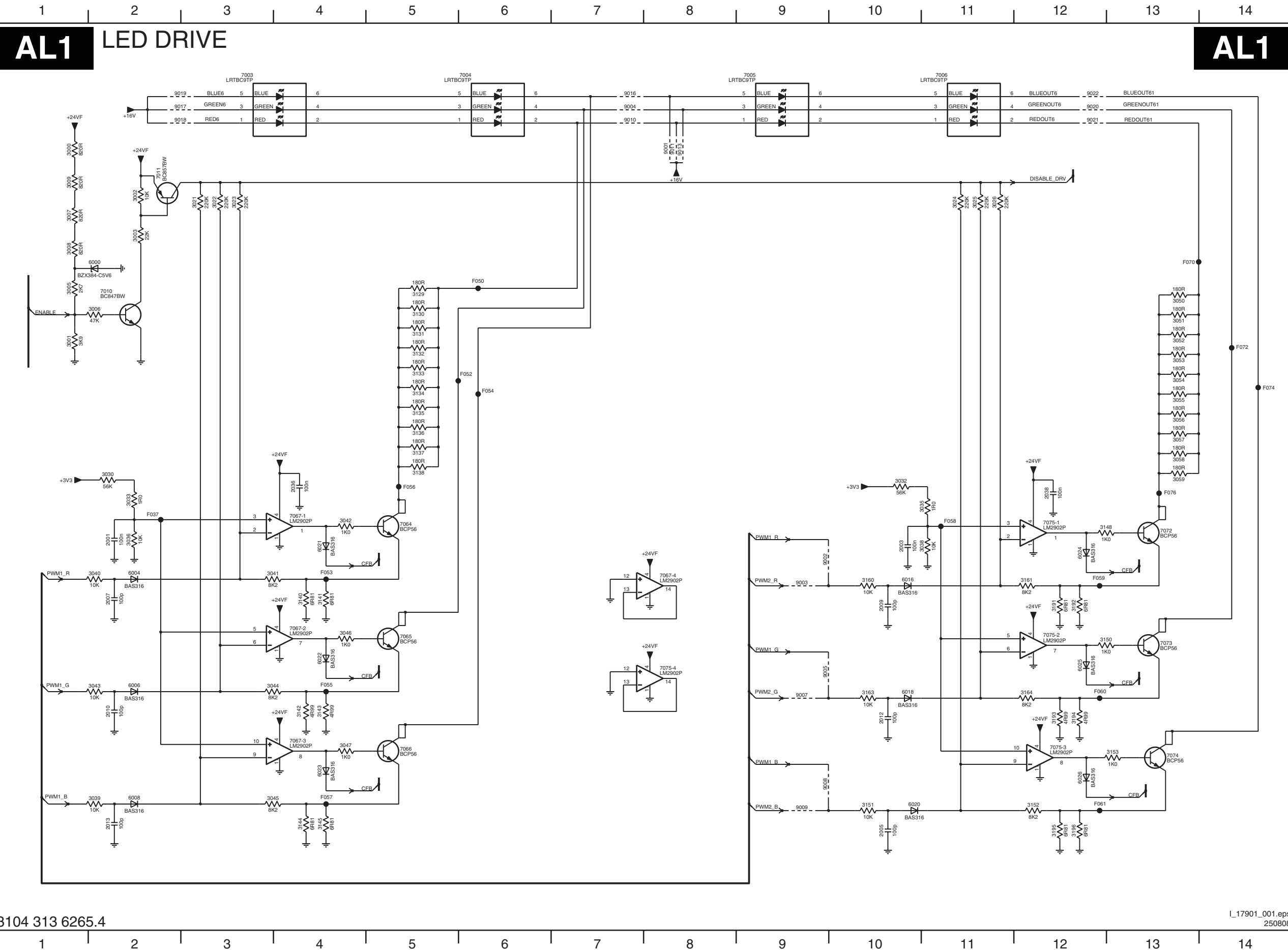

- 2001 F2
- 2003 F10
- 2005 I10
- 2007 F2
- 2009 F10
- 2010 H2
- 2012 H10
- 2013 I2
- 2036 E4
- 2038 E12
- 3000 A1
- 3001 D1
- 3002 B2
- 3003 B2
- 3005 C1
- 3006 C2
- 3007 B1
- 3008 C1
- 3009 B1
- 3021 B3
- 3022 B3
- 3023 B3
- 3024 B11
- 3025 B11
- 3030 E2
- 3032 E10
- 3033 E2
- 3035 E11
- 3036 F2
- 3038 F11
- 3039 H2
- 3040 F2
- 3041 F3
- 3042 E4
- 3043 G2
- 3044 G3
- 3045 H3
- 3046 G4
- 3047 H4
- 3050 C13
- 3051 C13
- 3052 D13
- 3053 D13
- 3054 D13
- 3055 D13
- 3056 D13
- 3057 E13
- 3058 E13
- 3059 E13
- 3129 C5
- 3130 C5
- 3131 C5
- 3132 D5
- 3133 D5
- 3134 D5
- 3135 D5
- 3136 E5
- 3137 E5
- 3138 E5
- 3140 F4
- 3141 F4
- 3142 H4
- 3143 H4
- 3144 I4
- 3145 I4
- 3148 F12
- 3150 G12
- 3151 I10
- 3152 I12
- 3153 H13
- 3160 F10
- 3161 F12
- 3163 G10
- 3164 G12
- 3191 F12
- 3192 F12
- 3193 H12
- 3194 H12
- 3195 I12
- 3196 I12
- 6000 C2
- 6004 F2
- 6006 G2
- 6008 H2
- 6016 F10
- 6018 G10
- 6020 I10
- 6021 F4
- 6022 G4
- 6023 H4
- 6024 F12
- 6025 G12
- 6026 H12
- 7003 A3
- 7004 A6
- 7005 A9
- 7006 A11
- 7010 C2
- 7011 B2
- 7064 F5
- 7065 G5
- 7066 H5
- 7067-1 E4
- 7067-2 G4
- 7067-3 H4
- 7067-4 F8
- 7072 F13
- 7073 G13
- 7074 H13
- 7075-1 F12
- 7075-2 G12
- 7075-3 H12
- 7075-4 G8
- 9001 A8
- 9002 F9
- 9003 F9
- 9004 A7
- 9005 G9
- 9007 G9
- 9008 H9
- 9009 I9
- 9010 A7
- 9011 A8
- 9013 A8
- 9016 A7
- 9017 A2
- 9018 A2
- 9019 A2
- 9020 A12
- 9021 A12
- 9022 A12
- F037 E2
- F050 C8
- F052 D6
- F053 F4
- F054 D6
- F055 G4
- F056 E5
- F057 H4
- F058 E11
- F059 F12
- F060 G12
- F061 I12
- F070 C13
- F072 D14
- F074 D14
- F076 E13

8 LED Lite-On Panel: uC Block

AL3 MICROCONTROLLER BLOCK

AL3

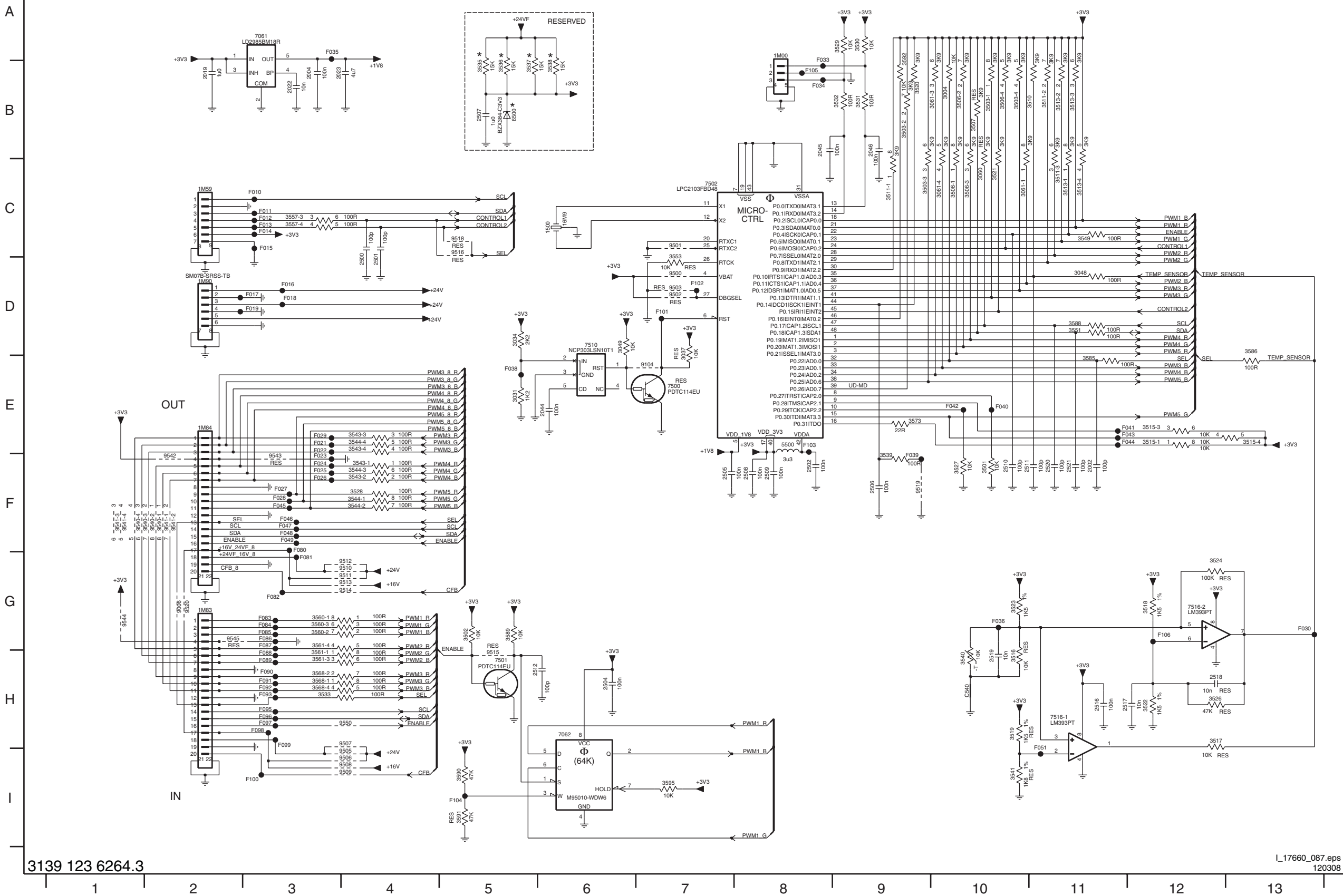

- 1500 C6
- 1M00 A8
- 1M59 C2
- 1M83 G2
- 1M84 E2
- 1M90 D2
- 2002 F11
- 2004 B3
- 2019 B2
- 2022 B3
- 2023 B3
- 2044 E6
- 2045 B8
- 2046 B9
- 2500 D4
- 2501 D4
- 2502 F8
- 2504 H6
- 2505 F7
- 2506 F9
- 2507 B5
- 2508 F8
- 2509 F8
- 2510 F10
- 2511 F10
- 2512 H5
- 2516 H11
- 2517 H11
- 2518 H12
- 2519 H10
- 2520 F11
- 2521 F11
- 3004 B10
- 3031 E5
- 3034 D5
- 3037 D7
- 3048 D11
- 3049 D6
- 3060 C10
- 3061-1 C10
- 3061-2 B10
- 3061-3 B10
- 3061-4 F1
- 3501 F10
- 3502 G5
- 3503-1 B10
- 3503-2 B9
- 3503-3 C9
- 3503-4 B10
- 3506-1 C10
- 3506-2 B10
- 3506-3 C10
- 3506-4 B10
- 3507 B10
- 3510 B11
- 3511-1 C9
- 3511-2 B11
- 3511-3 C11
- 3513-1 B11
- 3513-2 B11
- 3513-3 B11
- 3513-4 C11
- 3515-1 E12
- 3515-3 E12
- 3516 H10
- 3517 H12
- 3518 G12
- 3519 H10
- 3520 B9
- 3521 C10
- 3522 H12
- 3523 G10
- 3524 G12
- 3526 H12
- 3527 F10
- 3528 F4
- 3529 A9
- 3530 A9
- 3531 B9
- 3532 B9
- 3533 H3
- 3535 B5
- 3536 B5
- 3537 B5
- 3538 B6
- 3539 F9
- 3540 H10
- 3541 H10
- 3543-1 F4
- 3543-2 F4
- 3543-3 F4
- 3544-1 E4
- 3544-2 F4
- 3544-3 F4
- 3544-4 E4
- 3549 C11
- 3551 D11
- 3553 D7
- 3557-3 C3
- 3557-4 C3
- 3565 H3
- 3560-2 G3
- 3560-3 G3
- 3561-1 H3
- 3561-3 H3
- 3561-4 G3
- 3568-1 H3
- 3568-2 H3
- 3568-4 H3
- 3573 E9
- 3585 E11
- 3588 D13
- 3588 D11
- 3589 G5
- 3591 I5
- 3592 A9
- 3595 I7
- 5500 E8
- 6500 B5
- 7061 A3
- 7062 H6
- 7500 E7
- 7501 H5
- 7502 C7
- 7510 D6
- 7516-1 H11
- 7516-2 G12
- 9006 G2
- 9104 E7
- 9500 D7
- 9501 C7
- 9502 D7
- 9503 D7
- 9505 I4
- 9506 I4
- 9507 H4
- 9508 I4
- 9509 I4
- 9510 G4
- 9511 G4
- 9512 G4
- 9513 G4
- 9514 G4
- 9515 H5
- 9516 C5
- 9518 C5
- 9519 F9
- 9520 G2
- 9540-1 F2
- 9540-2 F2
- 9540-3 F1
- 9540-4 F1
- 9541-1 F2
- 9541-2 F2
- 9541-3 F1
- 9541-4 F1
- 9542 F2
- 9543 F3
- 9544 G1
- 9545 G2
- 9550 H4
- C540 H10
- F010 C3
- F011 C3
- F012 C3
- F013 C3
- F014 C3
- F015 C3
- F016 D3
- F017 D3
- F018 D3
- F019 D3
- F020 D3
- F021 D3
- F022 E3
- F023 F3
- F024 F3
- F025 F3
- F026 F3
- F027 F3
- F028 F3
- F029 F3
- F030 G13
- F031 B8
- F032 B8
- F033 B8
- F034 B8
- F035 A3
- F036 G10
- F037 F9
- F038 E5
- F039 F9
- F040 E10
- F041 E12
- F042 E10
- F043 E12
- F044 E12
- F045 F3
- F046 F3
- F047 F3
- F048 F3
- F049 F3
- F050 H11
- F080 F3
- F081 G3
- F082 G3
- F083 G3
- F084 G3
- F085 G3
- F086 G3
- F087 G3
- F088 H3
- F089 H3
- F090 H3
- F091 H3
- F092 H3
- F093 H3
- F094 H3
- F095 H3
- F096 H3
- F097 H3
- F098 H3
- F099 H3
- F100 I5
- F101 D7
- F102 D7
- F103 E8
- F104 I5
- F105 B8
- F106 G12

CLICK HERE TO **DOWNLOAD** THE COMPLETE MANUAL

- Thank you very much for reading the preview of the manual.
- You can download the complete manual from: www.heydownloads.com by clicking the link below



- Please note: If there is no response to CLICKING the link, please download this PDF first and then click on it.

CLICK HERE TO **DOWNLOAD** THE COMPLETE MANUAL

SSB: STI7100: Flash

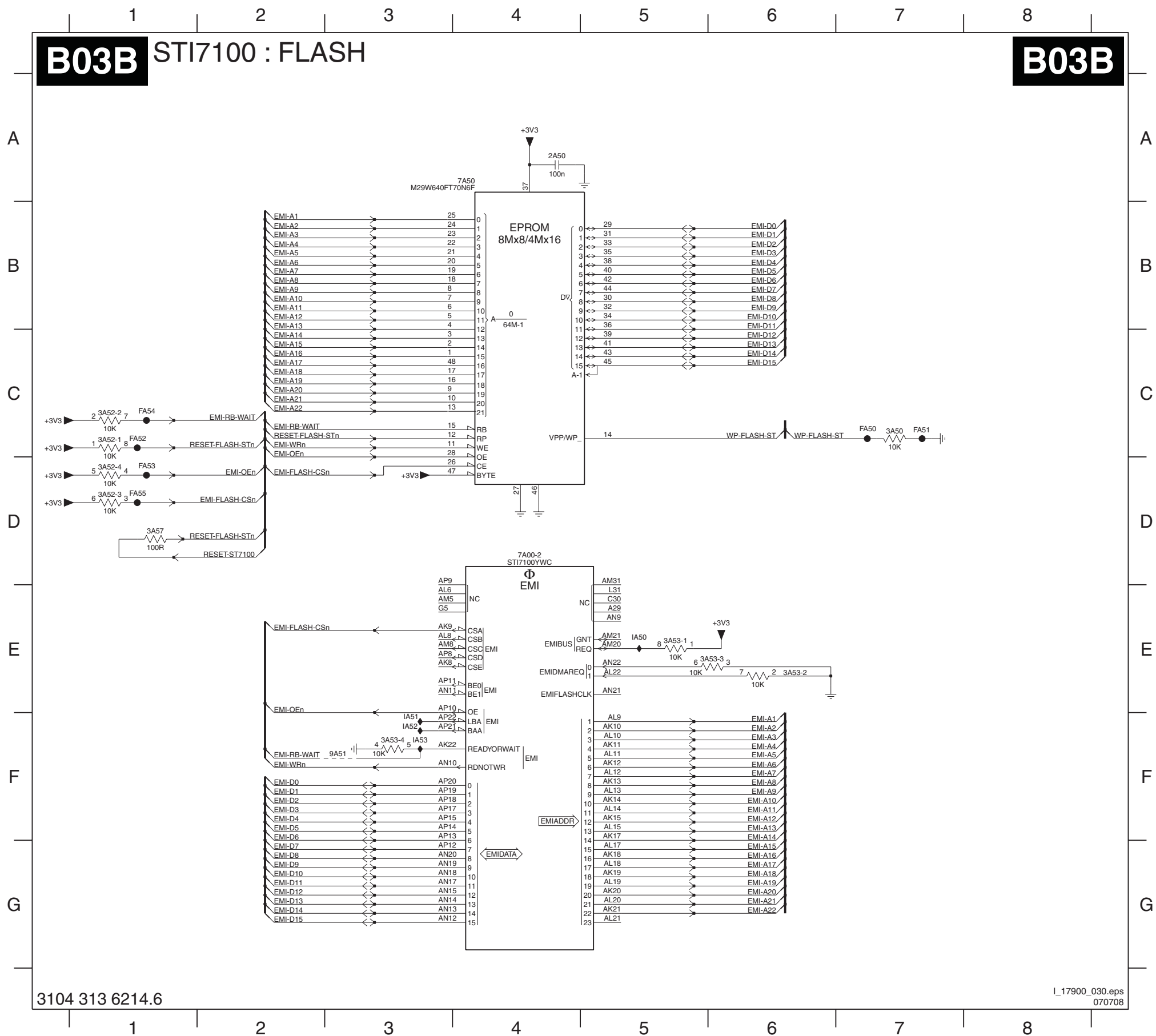

- 2A50 A4
- 3A50 C7
- 3A52-1 C1
- 3A52-2 C1
- 3A52-3 D1
- 3A52-4 D1
- 3A53-1 E5
- 3A53-2 E6
- 3A53-3 E6
- 3A53-4 F3
- 3A57 D1
- 7A00-2 D4
- 7A50 A4
- 9A51 F3
- FA50 C7
- FA51 C7
- FA52 C1
- FA53 D1
- FA54 C1
- FA55 D1
- IA50 E5
- IA51 F3
- IA52 F3
- IA53 F3

SSB: PNX8541: Control

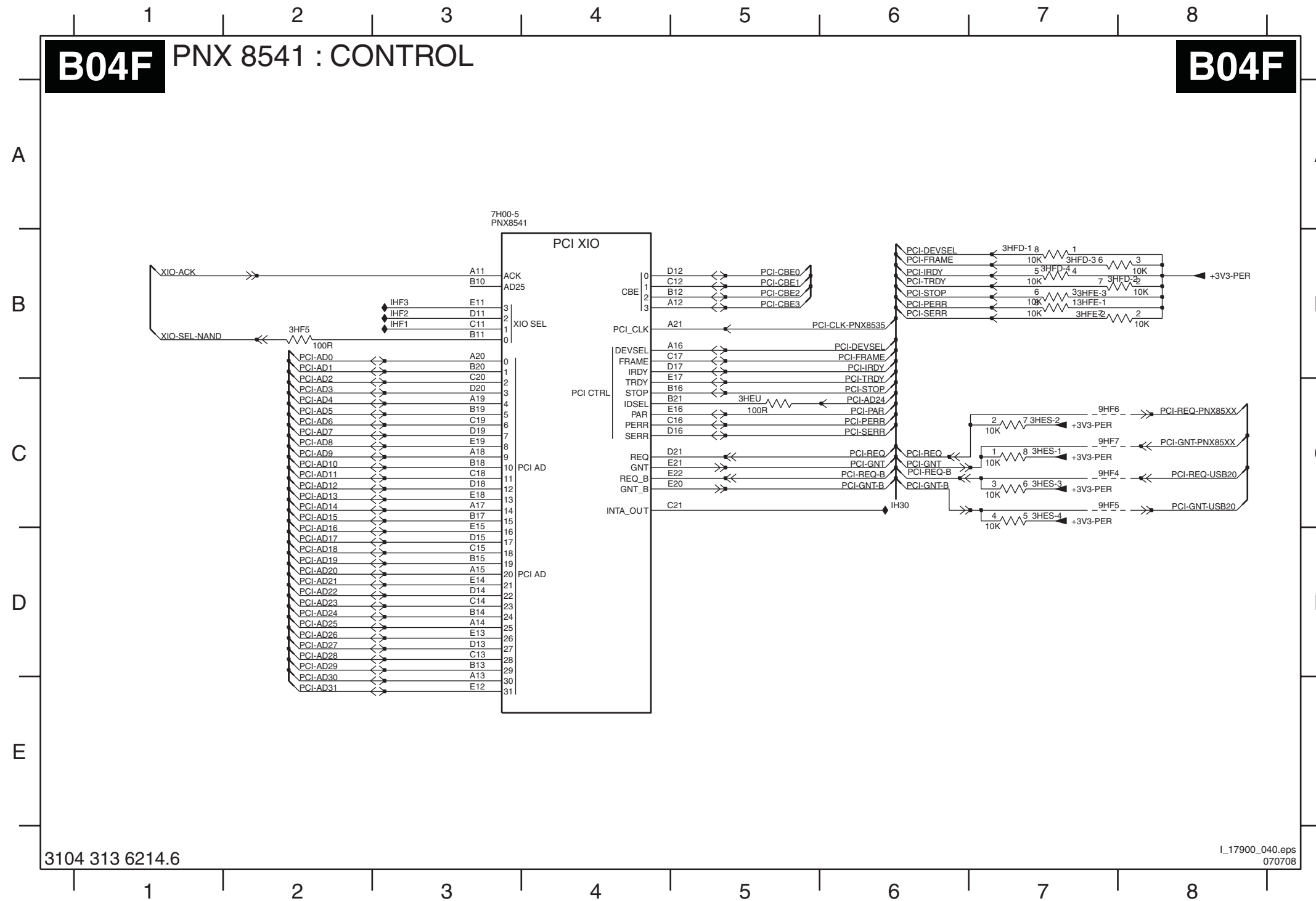

- 3HES-1 C7
- 3HES-2 C7
- 3HES-3 C7
- 3HES-4 C7
- 3HEU C5
- 3HF5 B2
- 3HFD-1 B7
- 3HFD-2 B8
- 3HFD-3 B7
- 3HFD-4 B7
- 3HFE-1 B7
- 3HFE-2 B7
- 3HFE-3 B7
- 7H00-5 A3
- 9HF4 C7
- 9HF5 C7
- 9HF6 C7
- 9HF7 C7
- IH30 C6
- IHF1 B2
- IHF2 B2
- IHF3 B2

SSB: PNX8541: Flash

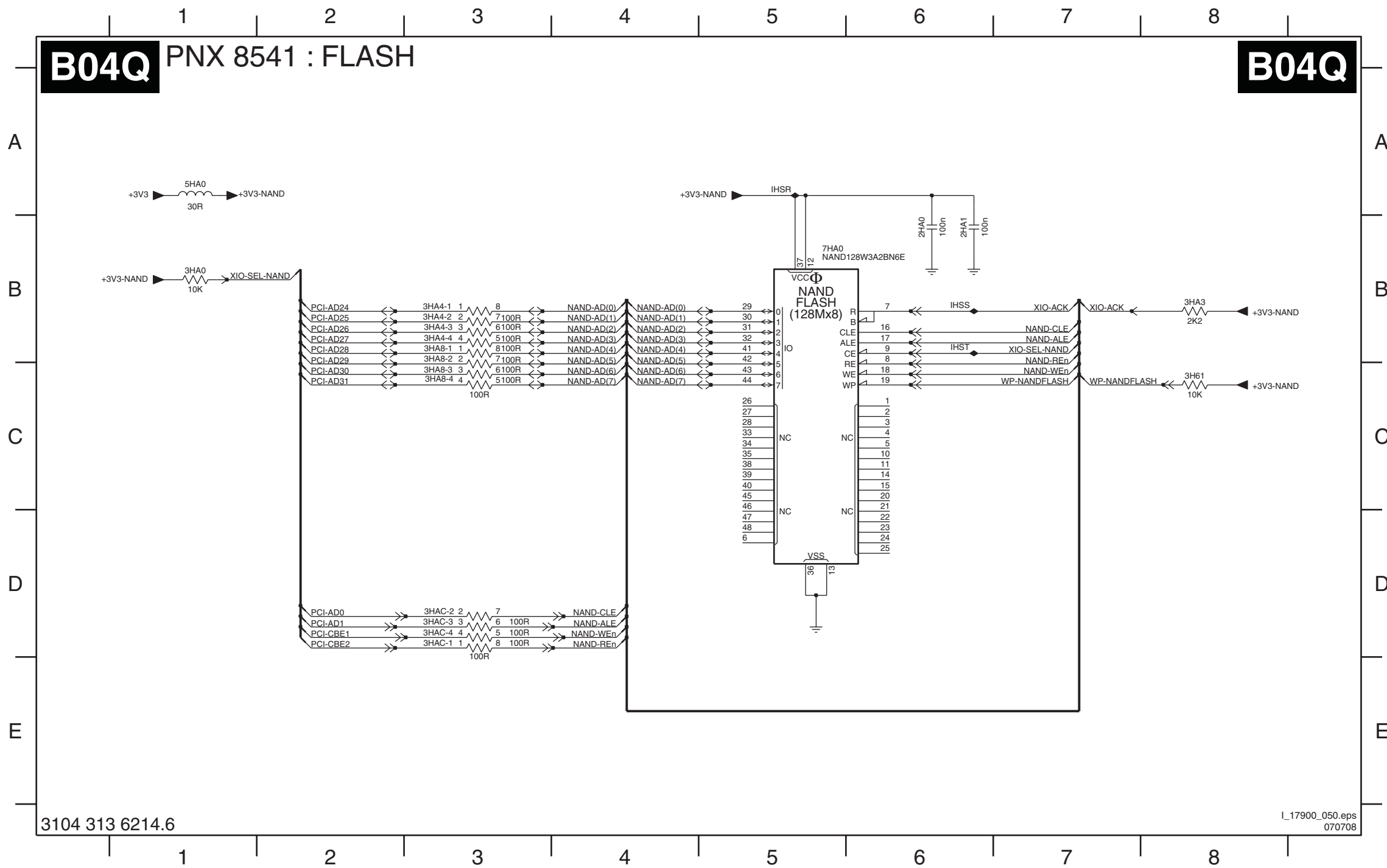

- 2HA0 B6
- 2HA1 B6
- 3H61 C8
- 3HA0 B1
- 3HA3 B8
- 3HA4-1 B3
- 3HA4-2 B3
- 3HA4-3 B3
- 3HA4-4 B3
- 3HA8-1 B3
- 3HA8-2 B3
- 3HA8-3 C3
- 3HA8-4 C3
- 3HAC-1 D3
- 3HAC-2 D3
- 3HAC-3 D3
- 3HAC-4 D3
- 5HA0 A1
- 7HA0 B5
- IHSR A5
- IHSS B6
- IHST B6

3104 313 6214.6

L_17900_050.eps
070708

SSB: FPGA Ambilight

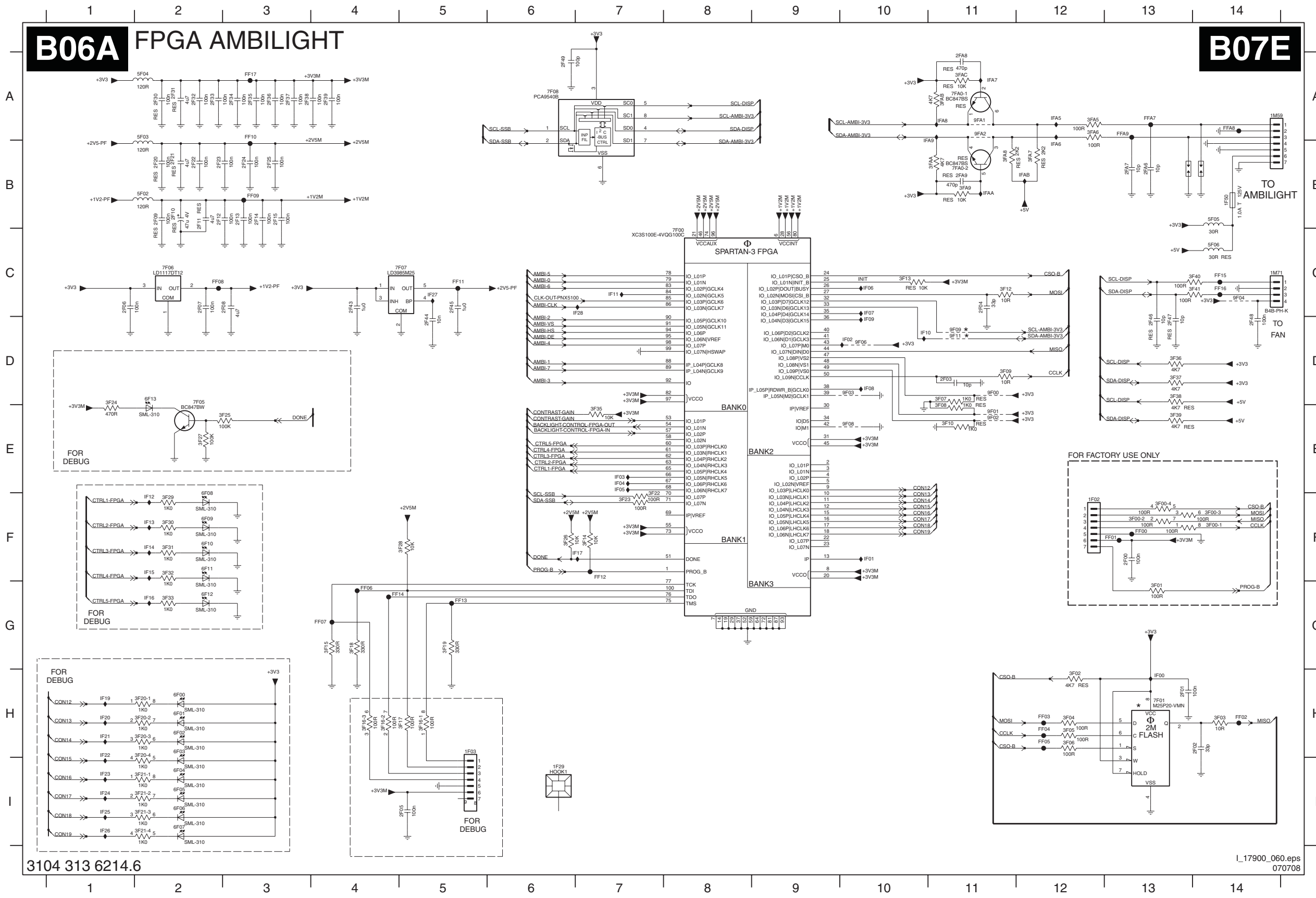

- 1F02 F12
- 1F03 H5
- 1F29 I6
- 1F50 B14
- 1M59 A14
- 1M71 C14
- 2F00 F13
- 2F01 H13
- 2F02 H14
- 2F03 D11
- 2F04 C11
- 2F05 I5
- 2F06 C1
- 2F07 C2
- 2F08 C2
- 2F09 B2
- 2F10 B2
- 2F11 B2
- 2F12 B2
- 2F13 B3
- 2F14 B3
- 2F15 B3
- 2F20 B2
- 2F21 B2
- 2F22 B2
- 2F23 B2
- 2F24 B3
- 2F25 B3
- 2F30 A2
- 2F31 A2
- 2F32 A2
- 2F33 A2
- 2F34 A3
- 2F35 A3
- 2F36 A3
- 2F37 A3
- 2F38 A3
- 2F39 A4
- 2F44 D5
- 2F45 C5
- 2F46 D13
- 2F47 D13
- 2F48 D14
- 2F49 A6
- 2FA6 B13
- 2FA7 B13
- 2FA8 A11
- 2FA9 B11
- 3F00-1 F14
- 3F00-2 F13
- 3F00-3 F14
- 3F00-4 F13
- 3F01 G13
- 3F02 H12
- 3F03 H14
- 3F04 H12
- 3F05 H12
- 3F06 H12
- 3F07 D11
- 3F08 E11
- 3F09 D11
- 3F10 E11
- 3F11 C11
- 3F12 C11
- 3F13 C10
- 3F14 F7
- 3F15 G4
- 3F16-1 H5
- 3F16-2 H4
- 3F16-3 H4
- 3F17 H4
- 3F18 G4
- 3F19 G5
- 3F20-1 H2
- 3F20-2 H2
- 3F20-3 H2
- 3F20-4 H2
- 3F21-1 I2
- 3F21-2 I2
- 3F21-3 I2
- 3F21-4 I2
- 3F22 F7
- 3F23 F7
- 3F24 D1
- 3F25 E3
- 3F26 F6
- 3F27 E2
- 3F28 F4
- 3F29 F2
- 3F30 F2
- 3F31 F2
- 3F32 F2
- 3F33 G2
- 3F35 E7
- 3F36 D13
- 3F37 D13
- 3F38 D13
- 3F39 E13
- 3F40 C14
- 3F41 C14
- 3FA5 A12
- 3FA6 A12
- 3FA7 B12
- 3FA8 B11
- 3FA9 B11
- 3FAA B11
- 3FAB A11
- 3FAC A11
- 5F02 B2
- 5F03 A2
- 5F04 A2
- 5F05 B14
- 5F06 C14
- 6F00 H2
- 6F01 H2
- 6F02 H2
- 6F03 H2
- 6F04 I2
- 6F05 I2
- 6F06 I2
- 6F07 I2
- 6F08 F2
- 6F09 F2
- 6F10 F2
- 6F11 F2
- 6F12 G2
- 6F13 D2
- 6F14 D2
- 7F00 C8
- 7F01 H13
- 7F02 C2
- 7F05 D2
- 7F06 C2
- 7F07 C5
- 7F08 A6
- 7FA0-1 A11
- 7FA0-2 B11
- 9F00 D11
- 9F01 E11
- 9F02 E11
- 9F03 D10
- 9F04 C14
- 9F05 D10
- 9F06 C10
- 9F08 D11
- 9F11 D11
- 9FA1 A11
- 9FA2 A11
- 9FA3 A11
- 9FA4 H12
- 9FA5 H12
- 9FA6 G2
- 9FA7 A13
- 9FA8 A13
- 9FA9 A13
- 9FAA A13
- 9FAB A13
- 9FAC A13
- 9F02 H2
- 9F03 H2
- 9F04 H2
- 9F05 H2
- 9F06 H2
- 9F07 H2
- 9F08 H2
- 9F09 H2
- 9F10 H2
- 9F11 H2
- 9F12 H2
- 9F13 H2
- 9F14 H2
- 9F15 H2
- 9F16 H2
- 9F17 H2
- 9F18 H2
- 9F19 H2
- 9F20 H2
- 9F21 H2
- 9F22 H2
- 9F23 H2
- 9F24 H2
- 9F25 H2
- 9F26 H2
- 9F27 H2
- 9F28 H2
- 9F29 H2
- 9F30 H2
- 9F31 H2
- 9F32 H2
- 9F33 H2
- 9F34 H2
- 9F35 H2
- 9F36 H2
- 9F37 H2
- 9F38 H2
- 9F39 H2
- 9F40 H2
- 9F41 H2
- 9F42 H2
- 9F43 H2
- 9F44 H2
- 9F45 H2
- 9F46 H2
- 9F47 H2
- 9F48 H2
- 9F49 H2
- 9F50 H2

3104 313 6214.6

L_17900_060.eps 070708

SSB: Analogue Externals C

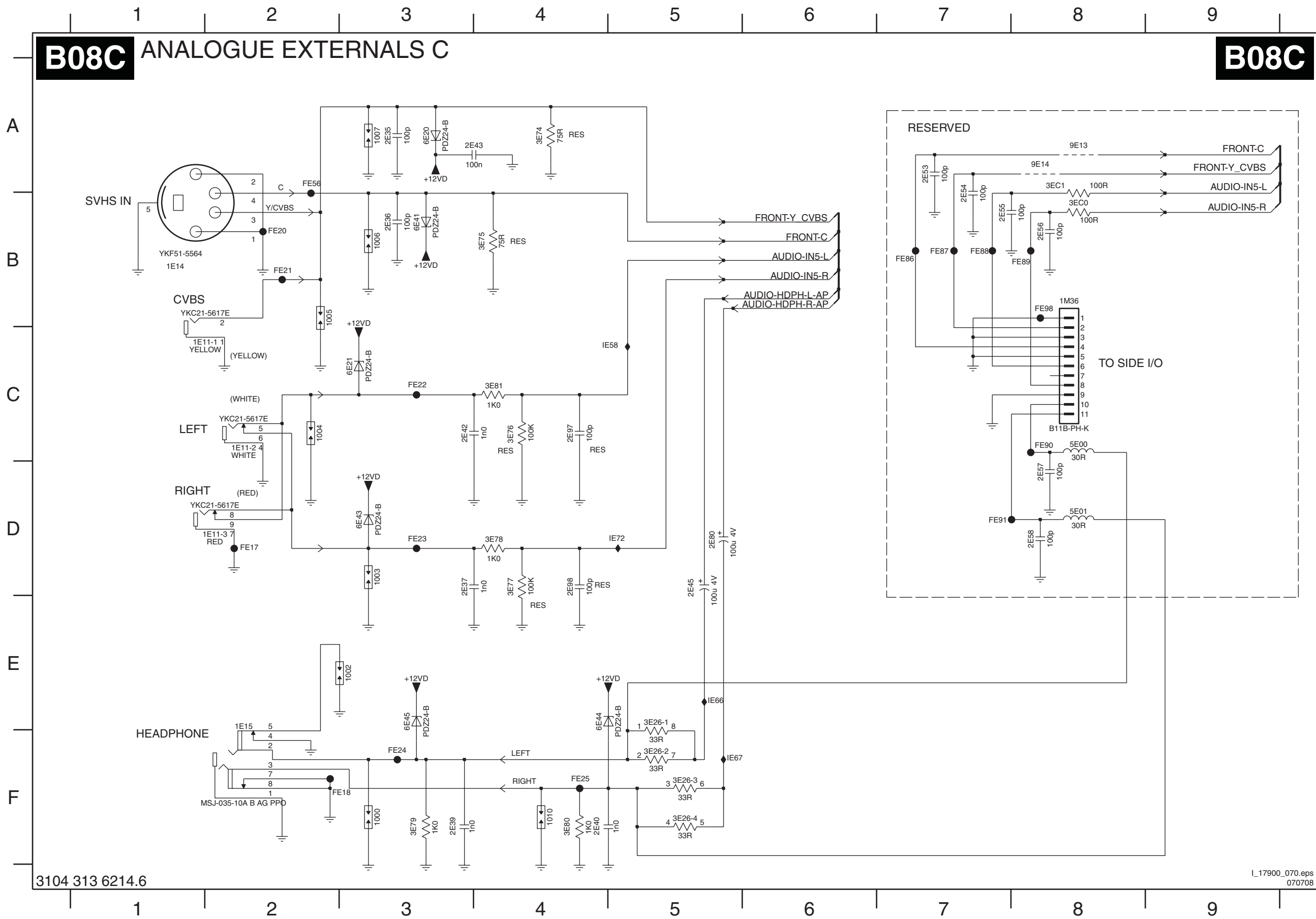

- 1000 F3
- 1002 E3
- 1003 D3
- 1004 C2
- 1005 B2
- 1006 B3
- 1007 A3
- 1010 F4
- 1E11-1 C2
- 1E11-2 C2
- 1E11-3 D2
- 1E14 B1
- 1E15 E2
- 1M36 B8
- 2E35 A3
- 2E36 B3
- 2E37 D3
- 2E39 F3
- 2E40 F4
- 2E42 C3
- 2E43 A4
- 2E45 D5
- 2E53 A7
- 2E54 B7
- 2E55 B7
- 2E56 B8
- 2E57 D8
- 2E58 D8
- 2E80 D5
- 2E97 C4
- 2E98 D4
- 3E26-1 E5
- 3E26-2 F5
- 3E26-3 F5
- 3E26-4 F5
- 3E74 A4
- 3E75 B4
- 3E76 C4
- 3E77 D4
- 3E78 D4
- 3E79 F3
- 3E80 F4
- 3E81 C4
- 3E80 B8
- 3EC1 A8
- 5E00 C8
- 5E01 D8
- 6E20 A3
- 6E21 C3
- 6E41 B3
- 6E43 D3
- 6E44 E4
- 6E45 E3
- 9E13 A8
- 9E14 A8
- FE17 D2
- FE18 F3
- FE20 B2
- FE21 B2
- FE22 C3
- FE23 D3
- FE24 F3
- FE25 F4
- FE56 A2
- FE86 B7
- FE87 B7
- FE88 B7
- FE89 B8
- FE90 C8
- FE91 D7
- FE98 B8
- IE58 C5
- IE66 E5
- IE67 F5
- IE72 D5

Layout Small Signal Board (Overview Top Side)

1735 D1	1E05 A6	1F03 A4	1M20 A4	1P03 F6	1T06 D7	2AEM G4	2C8Y A1	2D08 D2	2D19 D1	2D29 E1	2E03 A8	2E13 A7	2E23 A5	2E33 B7	2E43 D8	2E53 B8	2E67 A6	2E83 B6	2E93 B6	2EA4 B7	2EAM A8	2EAP A8	2P33 E5	3C0F C2	3EC5 A8	3P46 E6	5U02 F1	7P30 E8
1AC1 G4	1E06 A5	1F29 A3	1M36 B8	1P04 F5	1T08 C7	2AEU G4	2CG2 C1	2D09 D1	2D20 D2	2D30 E1	2E04 B8	2E14 B7	2E24 B8	2E34 B5	2E44 A8	2E54 B8	2E68 B6	2E84 A6	2E94 B6	2EA5 B7	2EAM A8	2EAP A8	2P34 E5	3C0K C2	3EC9 A8	3P48 E6	5U03 F1	7P02 F1
1AM0 G5	1E07 A5	1G50 A1	1M59 A3	1P05 F8	1T55 D8	2AEU G4	2CH0 C1	2D10 D1	2D21 D1	2D31 E1	2E05 A5	2E15 B7	2E25 B8	2E35 B5	2E45 C8	2E55 A8	2E69 B6	2E85 A6	2E95 B5	2EA9 A8	2EAM A8	2EAP A8	2P35 E5	3C0L C2	3EC9 A8	3P49 E6	5U04 F1	7P03 F1
1AM2 F5	1E10 C6	1G51 B1	1M71 A3	1P07 D8	1T60 C8	2CBL C1	2CH1 C1	2D11 D1	2D22 C1	2D32 D1	2E06 B8	2E16 B6	2E26 B8	2E36 D8	2E46 A6	2E56 A8	2E70 B6	2E86 B7	2E96 B5	2EA8 A8	2EAM A8	2EAP A8	2P36 E6	3C0M C2	3EC9 A8	3P50 E6	5U05 G2	7U08 F1
1C00 C1	1E11 C8	1H01 E1	1M95 F1	1P0A E7	1T65 C8	2CBM C1	2D02 D1	2D12 D1	2D23 D1	2D33 D1	2E07 A5	2E17 B6	2E27 A5	2E37 C8	2E47 A5	2E57 A8	2E71 B6	2E87 B7	2E97 B8	2EA8 A8	2EAM A8	2EAP A8	2P37 E6	3C0N C1	3EC9 A8	3P51 E6	5U06 G1	7U08 F2
1CJ0 A1	1E14 D8	1H10 B4	1M99 G1	1P0B E7	1T70 D8	2CBN C1	2D03 D1	2D13 D1	2D24 E1	2D34 D1	2E08 A5	2E18 B8	2E28 B5	2E38 B8	2E48 B6	2E58 A8	2E72 B6	2E88 B8	2E98 A8	2EAF B8	2EAM A8	2EAP A8	2P38 E6	3C0A C1	3EC9 A8	3P52 E6	5U08 F1	7U0D G1
1E01 A8	1E15 B8	1H11 D6	1N00 E4	1R07 B8	1T71 C8	2CBP C1	2D04 D2	2D14 D1	2D25 D1	2D35 C1	2E09 A8	2E19 A6	2E29 B6	2E39 B8	2E49 B5	2E59 B6	2E73 A6	2E89 B7	2E99 A5	2EAF B8	2EAM A8	2EAP A8	2P39 E5	3C0B C1	3EC9 A8	3P53 E6	5U09 G1	7U0H G2
1E02 A7	1E50 A5	1HE0 B5	1N01 D3	1R08 A8	1T75 D8	2CBR C1	2D05 D2	2D15 D1	2D26 D1	2D36 C1	2E10 B7	2E20 A8	2E30 B7	2E40 B8	2E50 B6	2E64 A6	2E74 A7	2E90 B7	2EA1 A8	2EAF B8	2EAM A8	2EAP A8	2P40 E5	3C0C C1	3ED1 A8	3P54 E6	6D01 E1	7U0M E1
1E03 A6	1E51 A5	1HFO A8	1P00 F7	1R12 A8	1U01 F7	2CBS C1	2D06 D1	2D16 D2	2D27 D1	2D37 C1	2E11 A6	2E21 B5	2E31 B7	2E41 A7	2E51 B7	2E65 A6	2E80 B8	2E91 B8	2EA2 A8	2EAF B8	2EAM A8	2EAP A8	2P41 A3	3C0D C1	3ED1 A8	3P55 E6	6E02 B7	7U0O G1
1E04 A5	1F02 A3	1M01 A4	1P02 F6	1R14 C7	2AEA G4	2CBW B1	2D07 D2	2D17 D2	2D28 D1	2E02 A8	2E12 A7	2E22 A5	2E32 B6	2E42 C8	2E52 A5	2E66 A6	2E82 B7	2E92 B6	2EA3 A8	2EAF B8	2EAM A8	2EAP A8	2P42 A3	3C0E C1	3F01 A3	3P56 E6	6E03 B7	7U0Q G1
																							2F00 A3	3C0F C1	3F02 A3	3P57 E6	6E04 B8	7U41 E2
																							2F01 A3	3C0G C1	3F03 A3	3P58 E6	6E05 A6	7U50 E1
																							2F02 A3	3C0H C1	3F04 A3	3P59 E6	6E06 B6	7U51 E1
																							2F03 A3	3C0I C1	3F05 A3	3P60 E6	6E07 B7	9AC3 G4
																							2F04 A4	3C0J C1	3F06 A3	3P61 E6	6E08 B7	9AM0 F5
																							2F05 A4	3C0K C1	3F07 A3	3P62 E6	6E09 B8	9AM1 F5
																							2F06 B4	3C0L C1	3F08 A3	3P63 E6	6E10 B6	9AC2 F5
																							2F07 A4	3C0M C1	3F09 A3	3P64 F6	6E11 A5	9C0H C1
																							2F08 A4	3C0N C1	3F10 A3	3P65 F6	6E12 B6	9C0I C1
																							2F09 B3	3C0O C1	3F11 B4	3P66 F6	6E13 A5	9D02 E2
																							2F10 B3	3C0P C1	3F12 B4	3P67 F6	6E14 B7	9D03 D1
																							2F11 A3	3C0Q C1	3F13 B4	3P68 F6	6E15 A5	9E00 A6
																							2F12 A3	3C0R C1	3F14 B4	3P69 F6	6E16 A5	9E01 A6
																							2F13 A3	3C0S C1	3F15 B4	3P70 F6	6E17 A5	9E02 A6
																							2F14 A3	3C0T C1	3F16 B4	3P71 F6	6E18 A6	9E04 A5
																							2F15 B3	3C0U C1	3F17 B4	3P72 E8	6E19 A8	9E04 A5
																							2F16 B3	3C0V C1	3F18 B4	3P73 E8	6E20 D8	9E06 A5
																							2F17 A3	3C0W C1	3F19 B4	3P74 E8	6E21 C8	9E10 A7
																							2F18 A3	3C0X C1	3F20 B4	3P75 E8	6E22 A8	9E11 A6
																							2F19 A3	3C0Y C1	3F21 B4	3P76 E8	6E23 B7	9E12 A6
																							2F20 A3	3C0Z C1	3F22 B4	3P77 E8	6E24 B6	9E13 D8
																							2F21 A3	3C0A C2	3F23 B4	3P78 E8	6E25 B7	9E14 D8
																							2F22 A3	3C0B C2	3F24 B4	3P79 E8	6E26 B7	9E14 D8
																							2F23 A3	3C0C C2	3F25 B4	3P80 E8	6E27 A7	9E15 A6
																							2F24 B3	3C0D C2	3F26 B4	3P81 E8	6E28 A7	9E15 A6
																							2F25 B3	3C0E C2	3F27 B4	3P82 E8	6E29 A7	9E16 B6
																							2F26 B3	3C0F C2	3F28 B4	3P83 E8	6E30 A7	9E17 A6
																							2F27 B3	3C0G C2	3F29 B4	3P84 E8	6E31 A6	9E18 A6
																							2F28 B3	3C0H C2	3F30 B4	3P85 G6	6E32 A8	9E20 A8
																							2F29 B3	3C0I C2	3F31 B4	3P86 G6	6E33 A6	9E20 A8
																							2F30 A3	3C0J C2	3F32 B4	3P87 G6	6E34 A6	9E21 A8
																							2F31 A3	3C0K C2	3F33 B4	3P88 G6	6E35 A6	9E21 A8
																							2F32 A3	3C0L C2	3F34 B4	3P89 G6	6E36 A7	9E22 A8
																							2F33 A3	3C0M C2	3F35 B4	3P90 G6	6E37 A7	9E23 A8
																							2F34 A3	3C0N C2	3F36 B4	3P91 G6	6E38 A6	9E24 A8
																							2F35 A3	3C0O C2	3F37 B4	3P92 G6	6E39 A6	9E25 A8
																							2F36 A3	3C0P C2	3F38 B4	3P93 G6	6E40 A6	9E25 A8
																							2F37 A3	3C0Q C2	3F39 B4	3P94 G6	6E41 D8	9E26 A8
																							2F38 A3	3C0R C2	3F40 B4	3P95 G6	6E42 A8	9E27 A8
																							2F39 B3	3C0S C2	3F41 B4	3P96 G6	6E43 A6	9E28 A8
																							2F40 A4	3C0T C2	3F42 B4	3P97 G6	6E44 A8	9E29 A8
																							2F41 A4	3C0U C2	3F43 B4	3P98 G6	6E45 A7	9E30 A8
																							2F42 A4	3C0V C2	3F44 B4	3P99 G6	6E46 A8	9E31 A8
																							2F43 A4	3C0W C2	3F45 B4	3P00 G6	6E47 A8	9E32 A8
																							2F44 A4	3C0X C2	3F46 B4	3P01 G6	6E48 A8	9E33 A8
																							2F45 A4	3C0Y C2	3F47 B4	3P02 G6	6E49 A8	9E34 A8
																							2F46 A4	3C0Z C2	3F48 B4	3P03 G6	6E50 A8	9E35 A8
																							2F47 A3	3C0A C3	3F49 B4	3P04 G6	6E51 A6	9E36 A8
																							2F48 A3	3C0B C3	3F50 B4	3P05 G6	6E52 A6	9E37 A8
																							2F49 A3	3C0C C3	3F51 B4	3P06 G6	6E53 A6	9E38 A8
																							2F50 A3	3C0D C3	3F52 B4	3P07 G6	6E54 A6	9E39 A8
																							2F51 A3	3C0E C3	3F53 B4	3P08 G6	6E55 A6	9E40 A8
																							2F52 A3	3C0F C3	3F54 B4	3P09 G6	6E56 A6	9E41 A8
																							2F53 A3	3C0G C3	3F55 B4	3P10 G6	6E57 A6	9E42 A8
																							2F54 A3	3C0H C3	3F56 B4	3P11 G6	6E58 A6	9E43 A8

AmbiLight Interface Panel

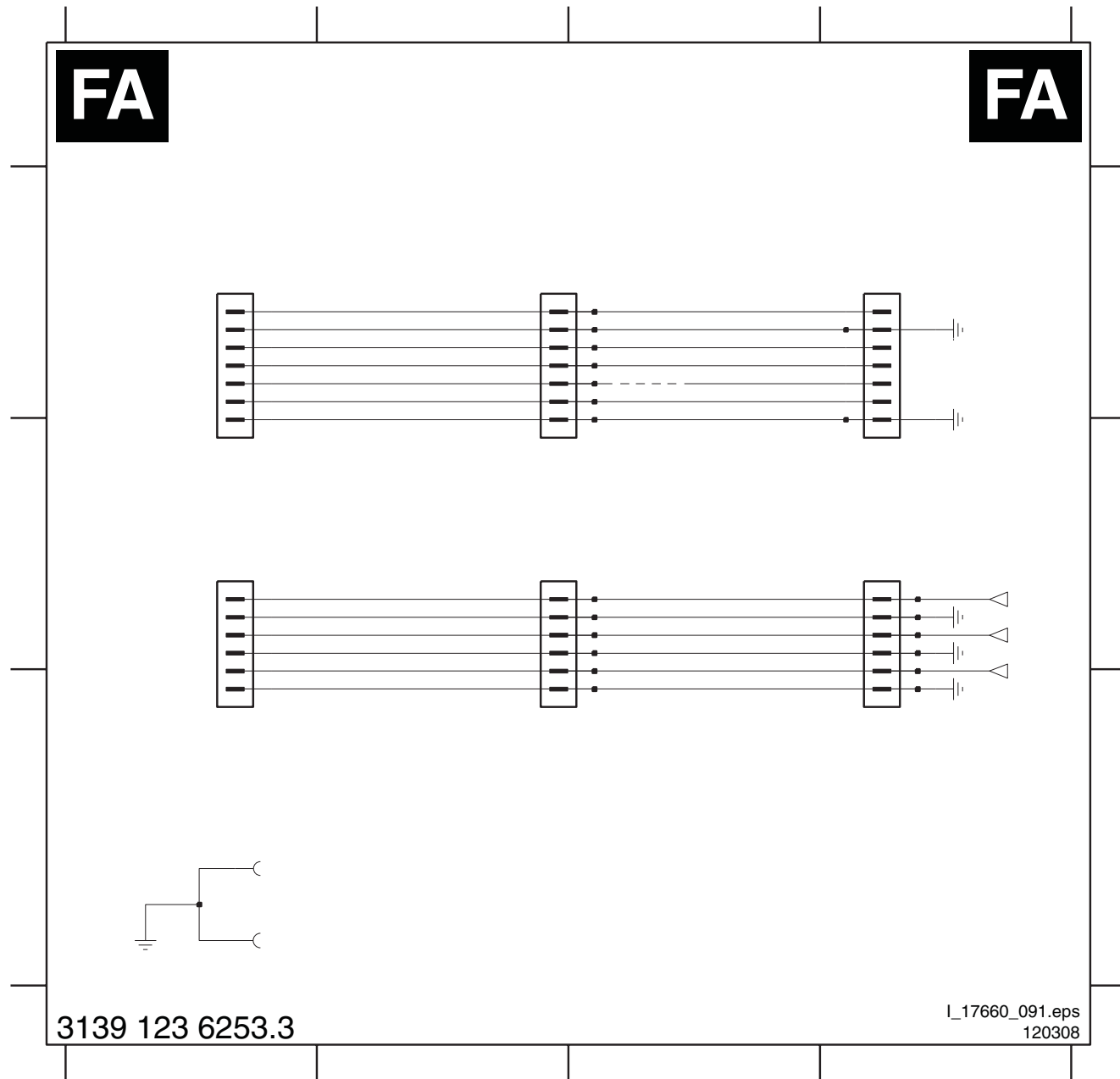

Layout AmbiLight Interface Panel (Top Side)

1M59 -- 1T59 -- 1T90 -- 1X00 --
 1M90 -- 1T60 -- 1T91 -- 1X01 --

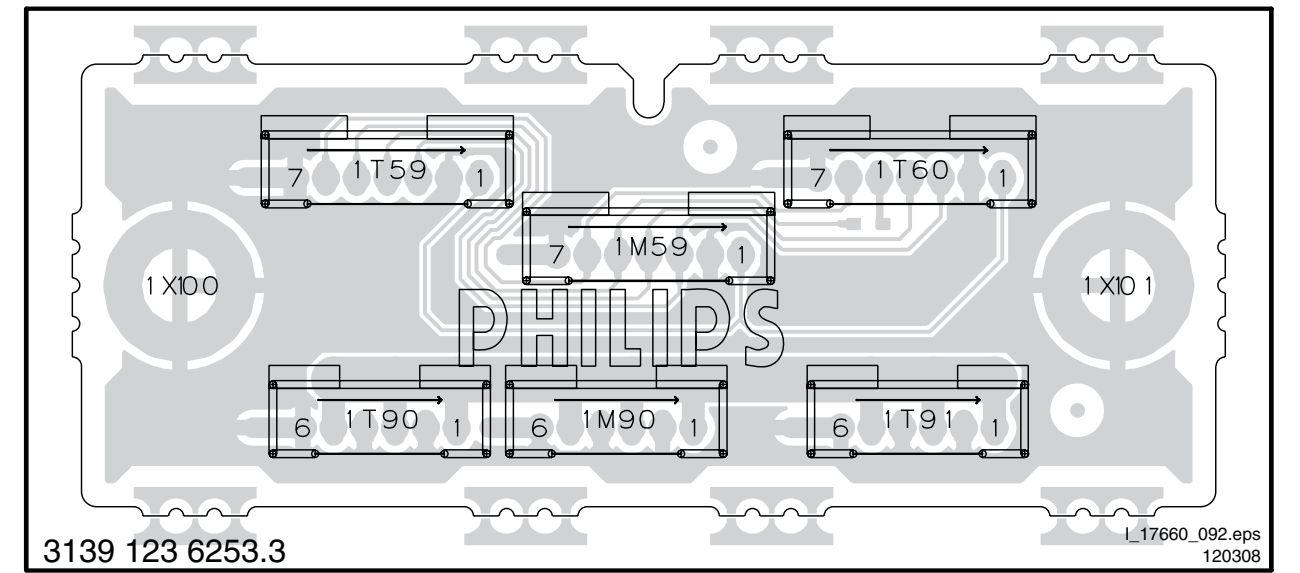

Layout AmbiLight Interface Panel (Bottom Side)

9M00 --

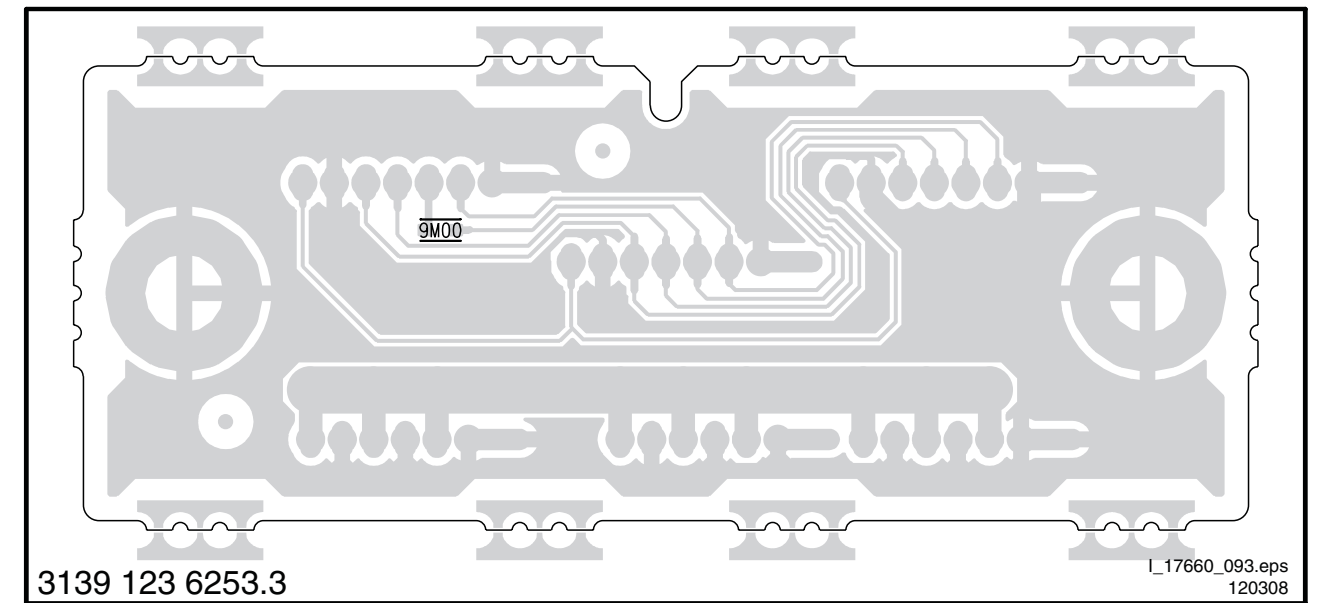

Service Tips

- When a power MOS-FET is found defective, replace the other power MOS-FET as well.
- For a normal operation of the converter, it is important to check the switching frequency and the value of the boost voltage.

9.5 Front-End

Refer to figure “9-1 System architecture.” earlier in this chapter for details. Refer also to block diagrams B02A, B02B and B02C.

9.5.1 Device specifications**Tuner (TD1716)**

The tuner has the following specifications:

- Hybrid tuner with symmetrical IF output.
- Down conversion from RF to IF frequency (picture carrier 39.875 MHz at analogue reception, centre frequency 36.166 MHz at digital reception).
- AGC control signal is coming from master IF device (TDA9898).
- Only 5 V external supply needed (internal DC-DC conversion to 3.3 V).
- 4 MHz output is used by channel decoder (TDA10048) and master IF device (TDA9898).

The application in this chassis is as follows:

- I²C address C0.
- Broadband AGC, no IF section.
- I²C communication buffered via MUX.
- Gain to obtain optimised Master IF input level; AGC control is completely inside the tuner.
- Output level ca. 110 dB μ V (for strong input signal).

Repair tip: after replacement of the tuner, the option code should be checked, even when the set appears to function correctly! Refer also to chapter 5 “Service Modes, Error Codes, and Fault Finding”.

Master IF (TDA9898)

- Down conversion from IF to low-IF frequency.
- Down conversion from IF to SIF.
- CVBS output.

The application in this chassis is as follows:

- I²C address 0x86.
- Down conversion from IF to low-IF frequency (5.166 MHz centre frequency).
- Advanced filtering (for further rejection of adjacent channels).
- Gain to obtain optimised channel decoder level. Control signal is coming from channel decoder.

SAW filter**X6874D and X3451K**

- Analogue sound for BG, I, DK, L, L’.
- DVB-T (digital reception sound **and** video).

For digital reception, the application in this chassis is as follows:

- Rejection of adjacent channels.
- Switching is done by Master IF (3 inputs).
- One SAW covering both 7 and 8 MHz channels.

X6774D

- Analogue video for BG, I, DK, L, L’.

Channel decoder (TDA10048) DVB-T

The channel decoder has the following specifications:

- I²C address 0x10.
- Decoding from low-IF to MPEG transport stream.
- During decoding: de-modulation, de-interleaving and error correction.
- External clock buffer required.
- No start-up requirements.
- AGC monitor.

Channel decoder (TDA10023) DVB-C

The channel decoder has the following specifications:

- I²C address 0x1C.
- Decoding from low-IF to MPEG transport stream.
- During decoding: de-modulation, de-interleaving and error correction.
- External clock buffer required.
- No start-up requirements.
- AGC monitor.

9.5.2 Digital signal processing (front-end)

Refer to figure “9-7 DVB-C signal broadcast reception block diagram” and “9-8 DVB-T signal broadcast reception block diagram” for details of digital signal processing.

9.12 IC Data Sheets

This section shows the internal block diagrams and pin configurations of ICs that are drawn as “black boxes” in the electrical diagrams (with the exception of “memory” and “logic” ICs).

9.12.1 Diagram AB, EP3C40F484C7N (IC 7F18)

Block Diagram

Cyclone III Device Architecture Overview Note (1)

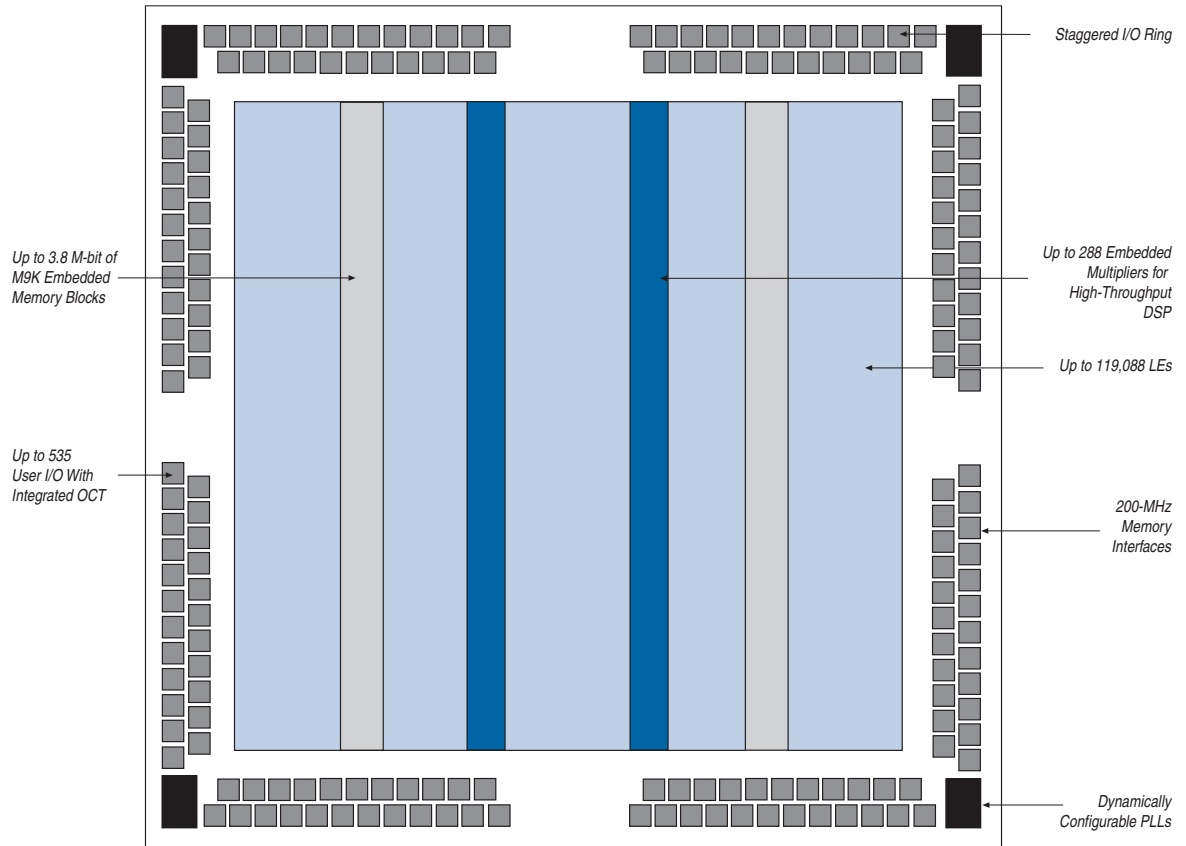

Note 1:
 (1) EP3C5 and EP3C10 have only two PLLs

Figure 9-14 Internal block diagram

CLICK HERE TO **DOWNLOAD** THE COMPLETE MANUAL

- Thank you very much for reading the preview of the manual.
- You can download the complete manual from: www.heydownloads.com by clicking the link below



- Please note: If there is no response to CLICKING the link, please download this PDF first and then click on it.

CLICK HERE TO **DOWNLOAD** THE COMPLETE MANUAL