

# Service Manual

Pioneer

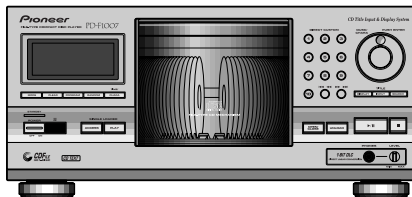

ORDER NO.  
RRV2001

FILE-TYPE CD PLAYER

# PD-F1007

THIS MANUAL IS APPLICABLE TO THE FOLLOWING MODEL(S) AND TYPE(S).

Type	Model	Power Requirement	Remarks
	PD-F1007		
KU	○	AC120V	

## CONTENTS

1. SAFETY INFORMATION .....	2	7. GENERAL INFORMATION .....	44
2. EXPLODED VIEWS AND PARTS LIST .....	3	7.1 PARTS .....	44
3. SCHEMATIC DIAGRAM .....	10	7.1.1 IC .....	44
4. PCB CONNECTION DIAGRAM .....	22	7.1.2 DISPLAY .....	47
5. PCB PARTS LIST .....	30	7.2 DIAGNOSIS .....	48
6. ADJUSTMENT .....	34	7.2.1 DISASSEMBLY .....	48
		7.2.2 ERROR CHECK DISPLAY .....	51
		7.2.3 EXPLANATION OF DISC DETECTION .....	52
		7.3 BLOCK DIAGRAM .....	54
		8. PANEL FACILITIES AND SPECIFICATIONS .....	55

CLICK HERE TO **DOWNLOAD** THE COMPLETE MANUAL

- Thank you very much for reading the preview of the manual.
- You can download the complete manual from: [www.heydownloads.com](http://www.heydownloads.com) by clicking the link below



- Please note: If there is no response to CLICKING the link, please download this PDF first and then click on it.

CLICK HERE TO **DOWNLOAD** THE COMPLETE MANUAL

### 3.2 LOADING SW, LOADING BOARD, SENSOR BOARD, RECIEVE BOARD, RADIATE BOARD and SELECT BOARD ASSEMBLIES

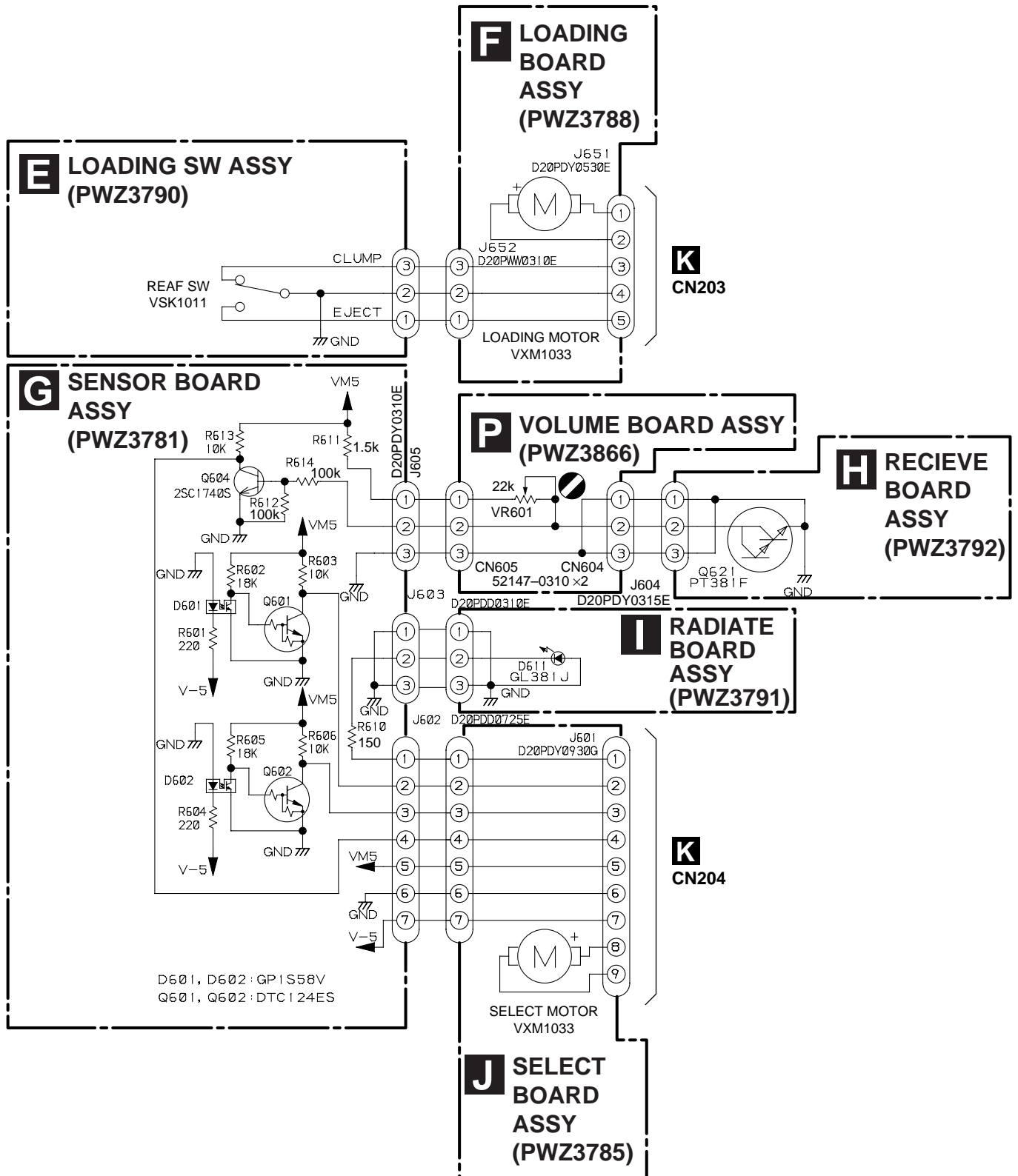

**K**  
CN11

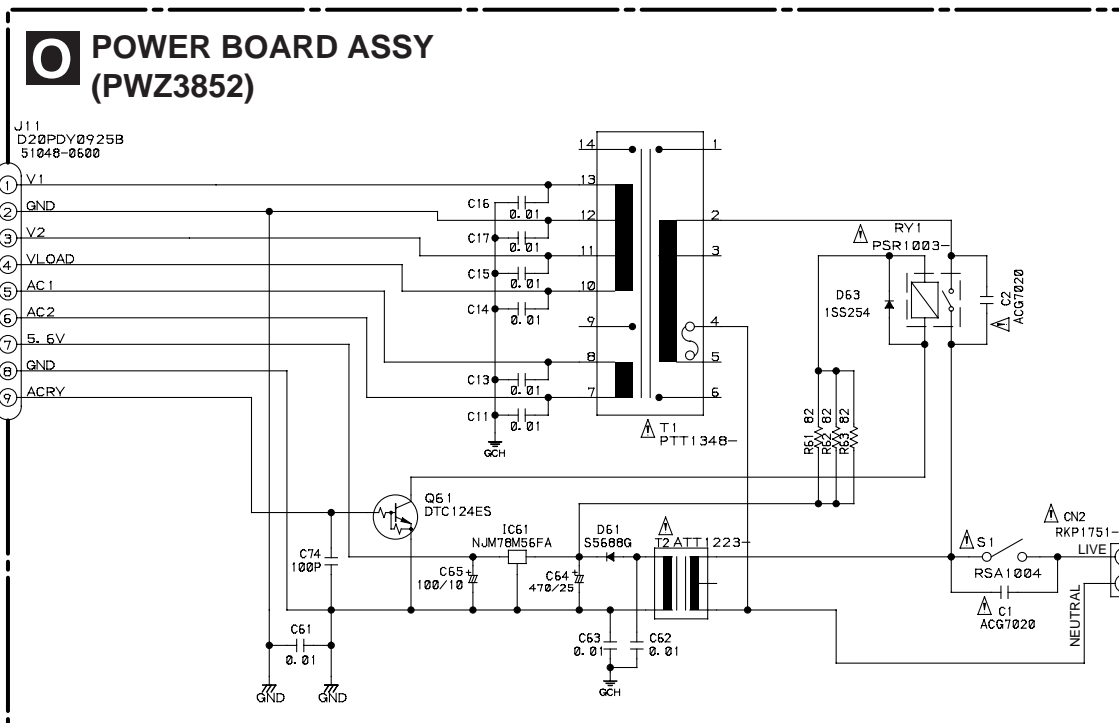

To AC POWER CORD

**K**  
CN401

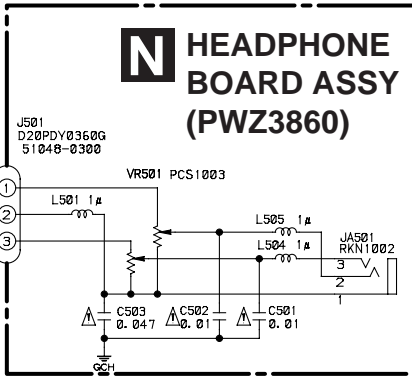

**NOTE**

RESISTORS

Unmarked RS1/10S\*\*\*J  
# RD1/4PU\*\*\*J

CAPACITORS

- (1) TL: Film CFTLA
- (2) YB: Ceramic CKSQYB
- (3) CH: Ceramic CKSQCH
- (4) YF: Ceramic CKCYF
- (5) SL: Ceramic CCCSL
- (6) Unmarked type CKSQYF
- (7) Unmarked CEAT

INDUCTORS

Axial: type LAU

OTHERS

⏏ : CHASSIS GROUND  
GND5

ABC: LOW ACTIVE SIGNAL

**M** FUNCTION BOARD ASSY (PWZ3847)

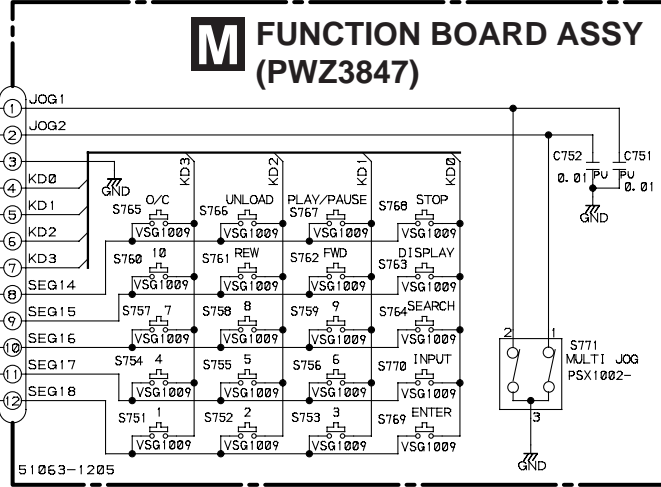

**FUNCTION BOARD ASSY**

- S751-S760 : DIRECT CUSTOM (1-10)
- S761 : Track/Manual search (reverse direction)
- S762 : Track/Manual search (forward direction)
- S763 : TITLE/DISPLAY
- S764 : TITLE/SEARCH
- S765 : OPEN/CLOSE
- S766 : UNLOAD
- S767 : Play/Pause
- S768 : Stop
- S769 : ENTER
- S770 : TITLE/INPUT
- S771 : Jog dial

**Mark No. Description Part No.**

**H RECIEVE BOARD ASSY**

**SEMICONDUCTORS**

Q621 PT381FBC

**OTHERS**

J604 CABLE HOLDER 51048-0300  
3P JUMPER WIRE D20PDY0315E

**K MAIN BOARD ASSY**

**SEMICONDUCTORS**

IC151 CXA1782CQ  
IC301 CXD2529Q  
⚠ IC35, IC36 ICP-N10  
⚠ IC203 LA6517  
⚠ IC201, IC202 LA6520

IC302 LC89170M  
IC406 M5218AFP  
IC352 M5M51008BFP-70LL  
⚠ IC405, IC407, IC408 NJM4558MD  
IC23 NJM79M05FA

⚠ IC351 PD4996A  
IC21 PQ05RR12  
IC25 S-806E  
IC951 TC74HC157AF  
Q151 2SA854S

Q391 2SC1740S  
Q362, Q381 2SC2412K  
Q351, Q403, Q404, Q413, Q414 2SD2144S  
Q423, Q424 2SD2144S  
Q152, Q363, Q382, Q406, Q416 DTA124EK

Q426 DTA124EK  
Q405, Q415, Q425 DTC124EK  
D351, D352, D391-D397, D958 1SS254  
D951, D953, D956, D957, D959 DA204K  
D54 MTZJ24B

⚠ D11-D14, D52 S5688G  
D218 UDZS6.2B

**COILS AND FILTERS**

L351 LAU100J  
L391, L395, L396 LAU1R0J

**CAPACITORS**

C449, C450 CCCSL101J50  
C181 CCSQCH100D50  
C361, C386 CCSQCH101J50  
C341, C342 CCSQCH120J50  
C435, C436, C455, C456 CCSQCH150J50

C315 CCSQCH221J50  
C481, C482 CCSQCH390J50  
C171, C175, C27, C29 CEAT101M10  
C301, C302, C311-C314, C316 CEAT101M10  
C322, C351, C365 CEAT101M10

**Mark No. Description Part No.**

C51 CEAT101M35  
C52 CEAT101M50  
C433, C434, C439, C440 CEAT220M25  
C131-C133, C211, C212 CEAT330M16  
C169, C170 CEAT4R7M50

C22 CEATR22M50  
C309 CEATR47M50  
C954 CFTLA104J50  
C441, C442 CKCYB102K50  
C317 CKCYF103Z50

C359, C398, C951, C952 CKCYF473Z50  
C163 CKSQYB102K50  
C156, C161, C164, C168, C218 CKSQYB103K50  
C153-C155, C158, C230, C250 CKSQYB104K25  
C176, C306 CKSQYB152K50

C305 CKSQYB222K50  
C162 CKSQYB332K50  
C160 CKSQYB333K25  
C167 CKSQYB472K50  
C152, C307 CKSQYB473K25

C151 CKSQYB682K50  
C157 CKSQYB823K25  
C159, C185, C191, C205, C210 CKSQYF103Z50  
C215, C219, C303, C308, C318 CKSQYF103Z50  
C331, C352, C353, C362, C363 CKSQYF103Z50

C381, C382, C411, C412, C953 CKSQYF103Z50  
C1431, C1432, C321 CKSQYF104Z50  
C354 (0.1F/5.5V) PCH1133  
C25, C26 (4700µF/16V) PCH1135

**RESISTORS**

R56-R59 RD1/4PU241J  
R52-R54 RD1/4PU272J  
R496, R499, R973, R974 RD1/4PU332J  
R977, R978 RD1/4PU332J  
R163, R164, R470, R471 RD1/4PU470J

VR153, VR155 (10kΩ) VCP1156  
VR151, VR152, VR154 (22kΩ) VCP1158  
VR156 (220kΩ) VCP1164  
Other Resistors RS1/10S □□□J

**OTHERS**

CN207 MT 4P CONNECTOR 173981-4  
CN208, CN401 3P JUMPER CONNECTOR 52147-0310  
CN205 4P JUMPER CONNECTOR 52147-0410  
CN203 5P JUMPER CONNECTOR 52147-0510  
CN11, CN204 9P JUMPER CONNECTOR 52147-0910

JA401, JA402 JACK DKB1031  
JA321 OPTICAL LINK OUT GP1F32T  
CN351 CONNECTOR HLEM16S-1  
JA393 JACK PKN1005  
X341 XTAL. RES. (16.9344MHz) PSS1008

### 8. RF Level Adjustment II

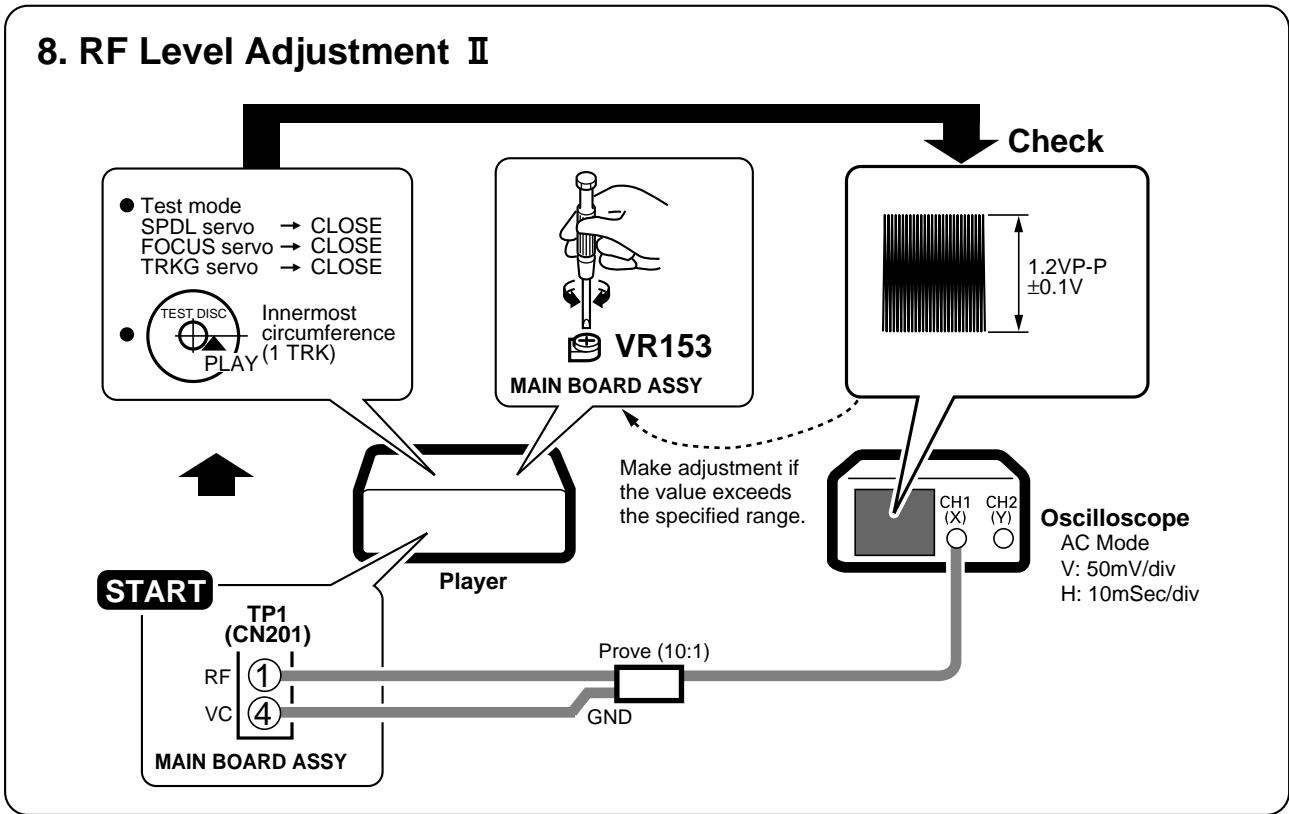

### 9. Focus Servo Loop Gain Adjustment I

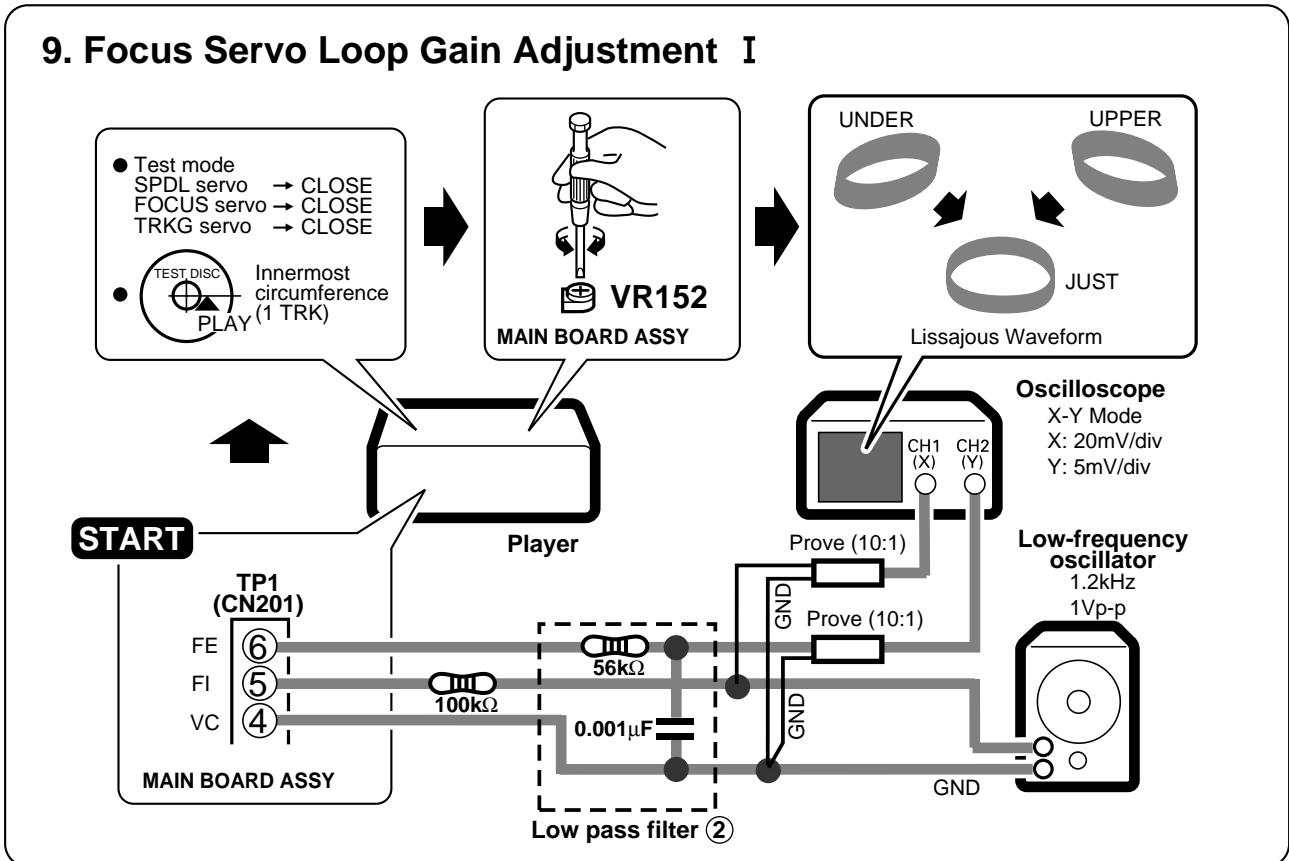

CLICK HERE TO **DOWNLOAD** THE COMPLETE MANUAL

- Thank you very much for reading the preview of the manual.
- You can download the complete manual from: [www.heydownloads.com](http://www.heydownloads.com) by clicking the link below



- Please note: If there is no response to CLICKING the link, please download this PDF first and then click on it.

CLICK HERE TO **DOWNLOAD** THE COMPLETE MANUAL

## 7.2.2 ERROR CHECK DISPLAY

Error check mode (display of the error history for the last 16 times) is entered when the "TIME/CHARA" button is pressed in test mode. By looking at this display, it can be seen in which status the microcomputer has stopped.

### (1) Explanation of the display

Disc No. = Error code

Track No. = Error history

Min : sec = Error occurrence mode

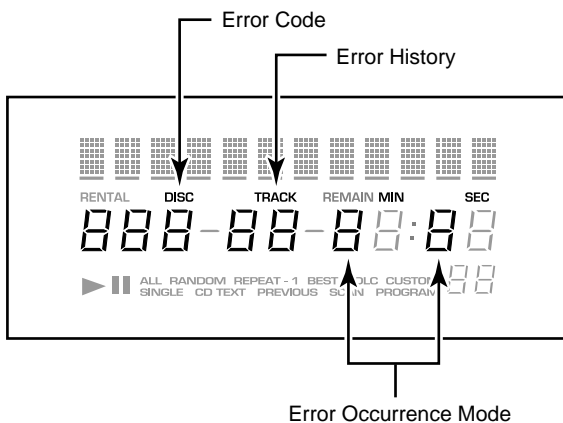

Press the "TIME/CHARA" button again to check past error codes. This switches the display. The contents of each display are as follows.

#### ① Track No.: Error History

Display is possible from 1 to 16. The smaller numbers have occurred more recently. Accordingly, the error No. 1 is the error which has occurred most recently.

#### ② Min : sec: Error Occurrence Mode

The internal mode at the time of occurrence of the displayed error is displayed. With Min : sec, the meaning is provided by the first digit.

Minutes digits

Display	Contents
0	During spindle stop operation
1	During disc return
2	During disc selection (during clamping operation at the time of 26)
3	During setup
4	During CDR setup operation
5	During TOC reading
6	During search operation on the disc
7	During play operation
8	During pause operation
9	During manual search

Seconds digits

Display	Contents
0	During hood closing operation and closed condition
1	During hood opening operation and open condition

#### ③ Disc No.: Error Code Details

Note: A used display is displayed only when return to normal operation after error occurrence is not possible even when failsafe operation is performed.

<<< Rack Section >>>

User Display	Display	Contents
None	A0	<ul style="list-style-type: none"> <li>Disc playing was tried after loading, but the disc could not be detected because there was no disc, the disc was upside down, the disc was dirty, disc loading had not been completed, etc.</li> <li>Focus was lost during disc playing because of disc scratches, dirt, etc.</li> </ul>
None	A1	<ul style="list-style-type: none"> <li>At the time of track selection during play, or when trying to play, the servo mechanism could not move to the position of the intended track within a fixed time.</li> </ul>
U1	A3	<ul style="list-style-type: none"> <li>Disc loading was tried, but loading was not possible within a fixed time. (The disc was not brought from the rack.)</li> </ul>
	A4	<ul style="list-style-type: none"> <li>It was tried to return the disc to the rack, but the disc could not be returned within a fixed time.</li> </ul>
U2	A2	<ul style="list-style-type: none"> <li>At the time of disc selection during play, or at the start of play from stopped condition, the selection mechanism could not move to the position of the intended disc within a fixed time.</li> </ul>
	A5	<ul style="list-style-type: none"> <li>After initialization of the selection mechanism, after selection mechanism NG, etc., forced rack section position detection is performed for the selection mechanism, but detection was not possible within a fixed time.</li> </ul>
None	A6	<ul style="list-style-type: none"> <li>Playing was tried after disc loading, but normal disc rotation was not possible because the disc was upside down, the disc was dirty, disc loading had not been completed, etc.</li> <li>During play normal rotation was not possible because of disc scratches, dirt, etc.</li> </ul>



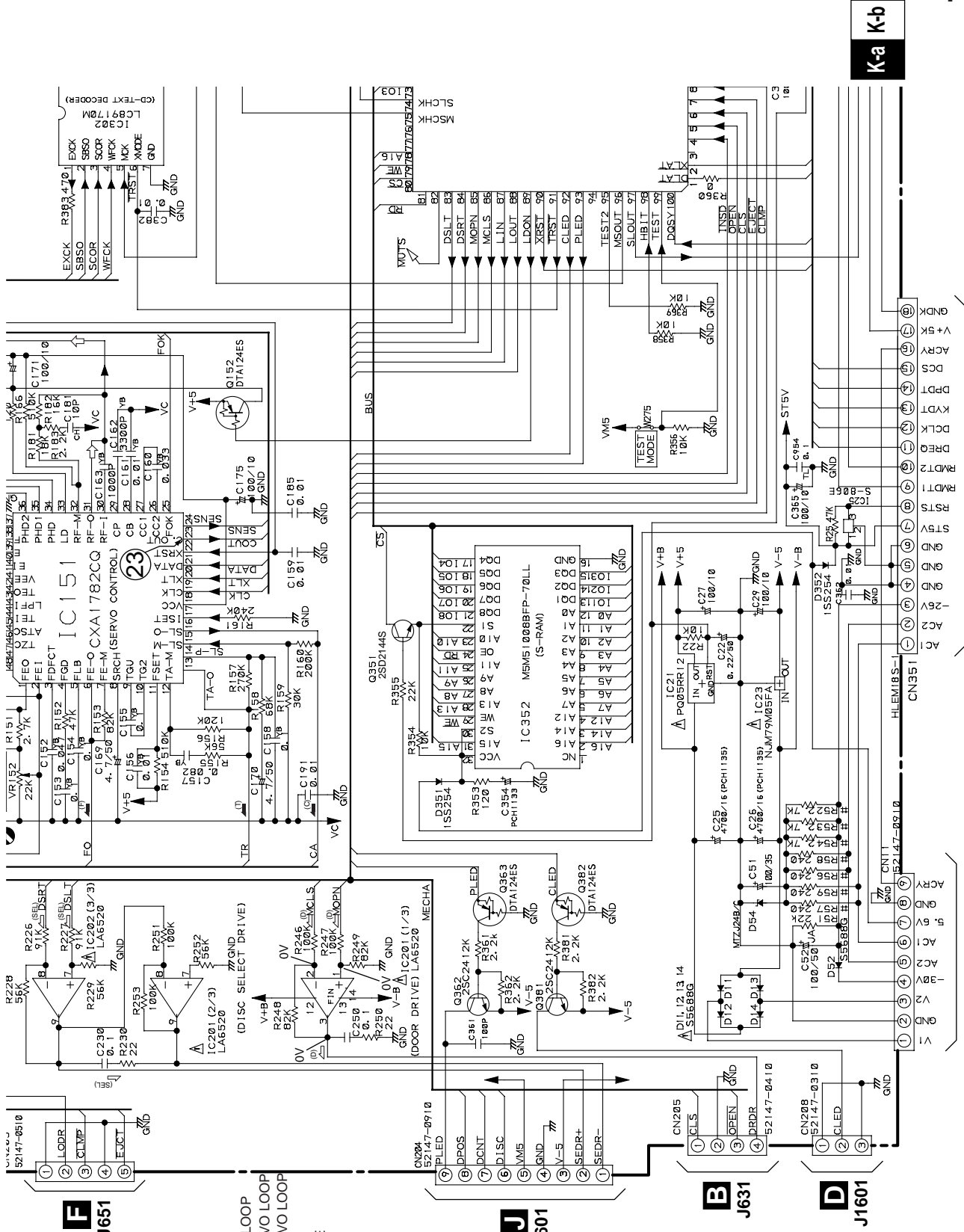

- SIGNAL ROUTE**
- ▶ : AUDIO SIGNAL
  - : EFM SIGNAL
  - ▲ : FOCUS SERVO LOOP
  - ▾ : TRACKING SERVO LOOP
  - ▴ : CARRIAGE SERVO LOOP
  - ▾ : SPINDLE DRIVE
  - ▴ : LOADING DRIVE
  - ▾ : DOOR DRIVE
  - ▴ : SELECT DRIVE

**F** J651

**J** J601

**B** J631

**D** J1601

**O** J11

**L** J701

**K-a** K-b

**K-a**



## 6.2 ADJUSTMENT

### 6.2.1 How to Start/Cancel Test Mode

#### TEST MODE : ON

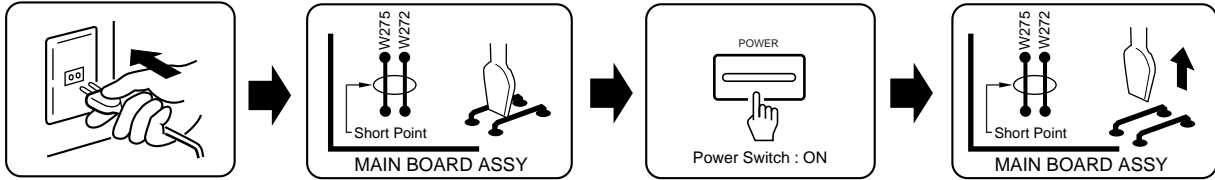

#### TEST MODE : PLAY

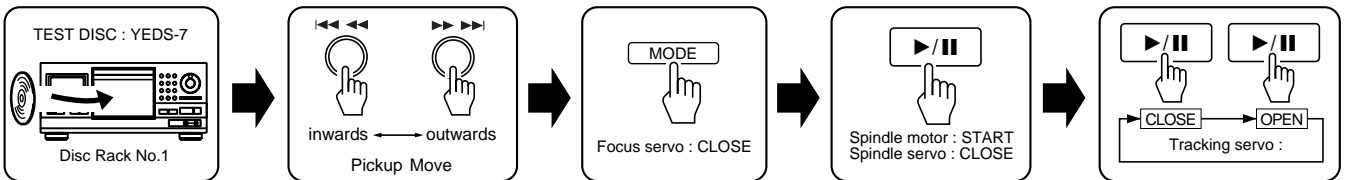

#### TEST MODE : STOP → CANCEL

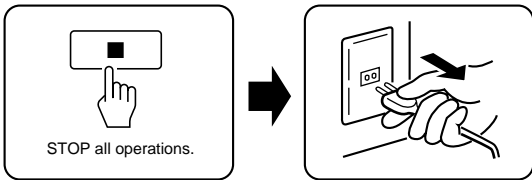

### 6.2.2 Adjustment Location

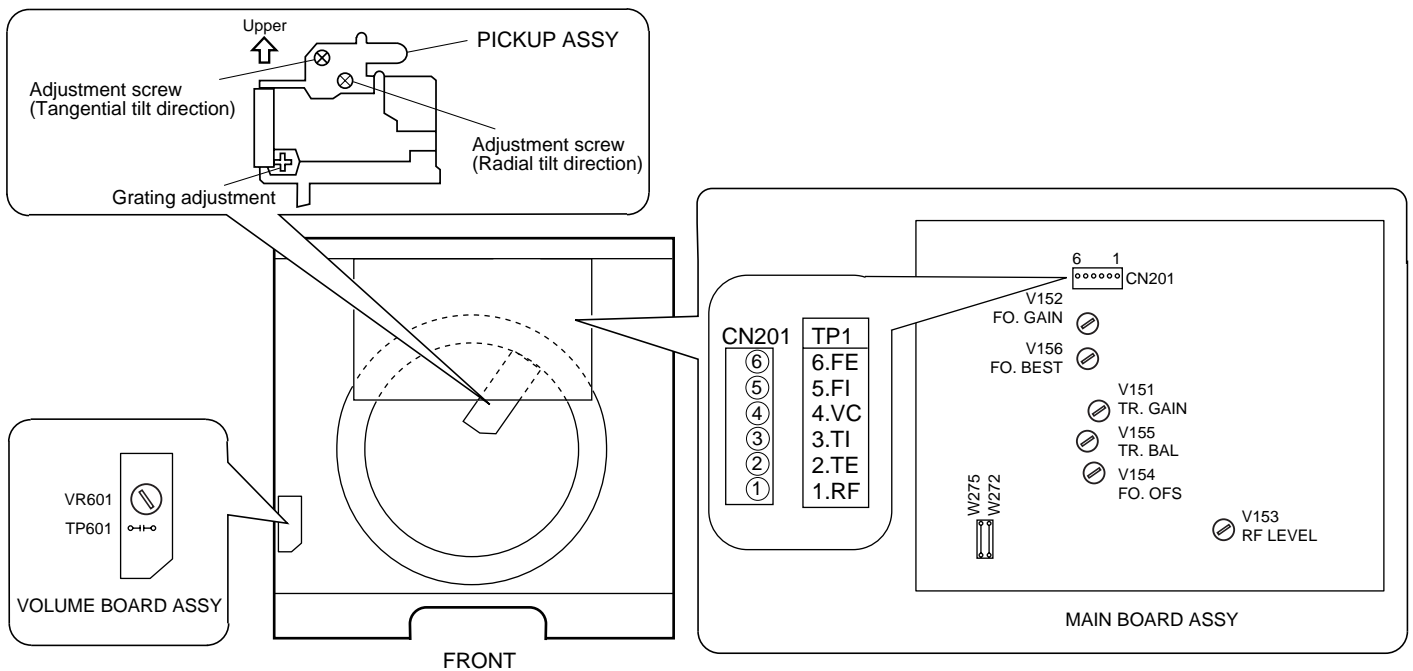

## ■ PD4996C(IC351: MAIN BOARD ASSY)

### ● System Control Micro-computer

#### ● Pin Function

No.	Symbol	Name	I/O	Description
1	P120/RTP0	$\overline{DLAT}$	O	DAC control data, latch pulse output
2	P121/RTP1	$\overline{XLAT}$	O	LSI control data, latch pulse output
3	P122/RTP2	Not used	O	Output of "L"
4	P123/RTP3	$\overline{INSD}$	I	Slider INSIDE switch input (L: INSIDE)
5	P124/RTP4	$\overline{OPEN}$	I	Hood open switch input (L: Opening completed)
6	P125/RTP5	$\overline{CLS}$	I	Hood close switch input (L: Closing completed)
7	P126/RTP6	$\overline{EJCT}$	I	Loading out switch input (L: Ejection completed)
8	P127/RTP7	$\overline{CLMP}$	I	Loading mechanism clamping switch input (L: Clamping completed)
9	IC	IC	-	GND
10	X2	X2	-	Connected to System clock oscillator (4.19 MHz)
11	X1	X1	-	
12	VDD	VDD	-	+5V
13	XT2	XT2	-	Not Connect (open)
14	P07/XT1	Not used	I	Input of 5 V (only for input)
15	$\overline{RESET}$	$\overline{RESET}$	I	CPU reset (L: Reset)
16	P00/INTP0/TI00	DREQ	I	Communication start request input from the SUD microcomputer (L: Communication start)
17	P01/INTP1/TI01	Not used	O	Output of "L"
18	P02/INTP2	DPOS	I	Pulse input for disc position detection
19	P03/INTP3	SCOR	I	Subcode synchronization S0 + S1 input
20	P04/INTP4	DISC	I	Disc detection pulse input (L: Disc present)
21	P05/INTP5	Not used	O	Not used
22	P06/INTP6	DCNT2	I	Disc count pulse input 2
23	AVdd	AVdd	-	VDD
24	AVref0	AVref0	-	GND
25	P10/ANI0	Not used	O	Output of "L"
26	P11/ANI1	MUTM	O	Master side mute output (L: Mute)
27	P12/ANI2	MUTA	O	Audio muting output (L: Mute)
28	P13/ANI3	Not used	O	Output of "L"
29	P14/ANI4	MSIN	I	Master input (response from the slave)
30	P15/ANI5	KYCON	O	Keyboard power supply control (H: Power ON)

No.	Symbol	Name	I/O	Description
31	P16/ANI6	SYNC1	I	Synchronization input (pull-up required)
32	P17/ANI7	SYNC3	O	Synchronization output
33	AVSS	AVSS	-	GND
34	P130/AN00	Not used	O	Output of "L"
35	P131/AN01	Not used		
36	AVref1	AVref1	-	VDD
37	P70/SI2/RxD	SRDT	I	CD TEXT data input
38	P71/SO2/TxD	Not used	O	Output of "L"
39	P71/ $\overline{SCK2}$ /ASCK	SCLK	O	CD TEXT data fetch clock output
40	Vss	Vss	-	GND
41	P20/SI1	KYDT	I	Communication data input in regard to the SUB microcomputer
42	P21/SO1	DPDT	O	Communication data output in regard to the SUB microcomputer
43	P22/ $\overline{SCK1}$	DCLK	O	Communication clock in regard to the SUB microcomputer
44	P23/STB	DCS	O	Communication request output in regard to the SUB microcomputer (H → L: Communication request)
45	P24/BUSY	Not used	O	Output of "L"
46	P25/SI0/SB0	SQSO	I	Q data serial input (combined use for FCOK/GFS/SENS)
47	P26/SO0/SB1	MDAT	O	LSI control data serial output
48	P27/ $\overline{SCK0}$	CLOCK	O	Serial clock
49   56	P80/A0   P87/A7	A0   A7	O	External RAM address line
57	P40/AD0	A4	O	
58	P41/AD1	A12	O	
59	P42/AD2	A10	O	
60	P43/AD3	A11	O	
61	P44/AD4	A9	O	
62	P45/AD5	A8	O	
63	P46/AD6	A13	O	
64	P47/AD7	A15	O	
65   69	P50/A8   P54/A12	IO4   IO8	O	External RAM data Input/Output
70	P55/A13	IO1	O	

CLICK HERE TO **DOWNLOAD** THE COMPLETE MANUAL

- Thank you very much for reading the preview of the manual.
- You can download the complete manual from: [www.heydownloads.com](http://www.heydownloads.com) by clicking the link below



- Please note: If there is no response to CLICKING the link, please download this PDF first and then click on it.

CLICK HERE TO **DOWNLOAD** THE COMPLETE MANUAL