

# Service Manual

**Pioneer**

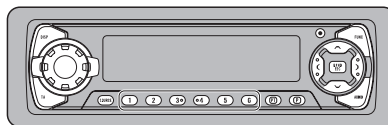

ORDER NO.  
CRT2466

MULTI-CD CONTROL HIGH POWER CD PLAYER WITH RDS TUNER

# DEH-P5100R X1N/EW

## DEH-P5100R-W X1NEW

## DEH-P5100R-B X1NEW

● This service manual should be used together with the following manual(s):

Model No.	Order No.	Mech. Module	Remarks
CX-958	CRT2423	S8.1	CD Mech. Module:Circuit Description, Mech. Description, Disassembly

## CONTENTS

1. SAFETY INFORMATION .....	2	7. GENERAL INFORMATION .....	49
2. EXPLODED VIEWS AND PARTS LIST .....	3	7.1 DIAGNOSIS .....	49
3. BLOCK DIAGRAM AND SCHEMATIC DIAGRAM ...	10	7.1.1 TEST MODE .....	49
4. PCB CONNECTION DIAGRAM .....	28	7.1.2 DISASSEMBLY .....	53
5. ELECTRICAL PARTS LIST .....	38	7.2 PARTS .....	57
6. ADJUSTMENT.....	45	7.2.1 IC.....	57
		7.2.2 DISPLAY .....	63
		7.3 OPERATIONAL FLOW CHART .....	64
		8. OPERATIONS AND SPECIFICATIONS.....	65

**PIONEER CORPORATION** 4-1, Meguro 1-Chome, Meguro-ku, Tokyo 153-8654, Japan  
**PIONEER ELECTRONICS SERVICE INC.** P.O.Box 1760, Long Beach, CA 90801-1760 U.S.A.  
**PIONEER EUROPE N.V.** Haven 1087 Keetberglaan 1, 9120 Melsele, Belgium  
**PIONEER ELECTRONICS ASIACENTRE PTE.LTD.** 253 Alexandra Road, #04-01, Singapore 159936

CLICK HERE TO **DOWNLOAD** THE COMPLETE MANUAL

- Thank you very much for reading the preview of the manual.
- You can download the complete manual from: [www.heydownloads.com](http://www.heydownloads.com) by clicking the link below



- Please note: If there is no response to CLICKING the link, please download this PDF first and then click on it.

CLICK HERE TO **DOWNLOAD** THE COMPLETE MANUAL

A

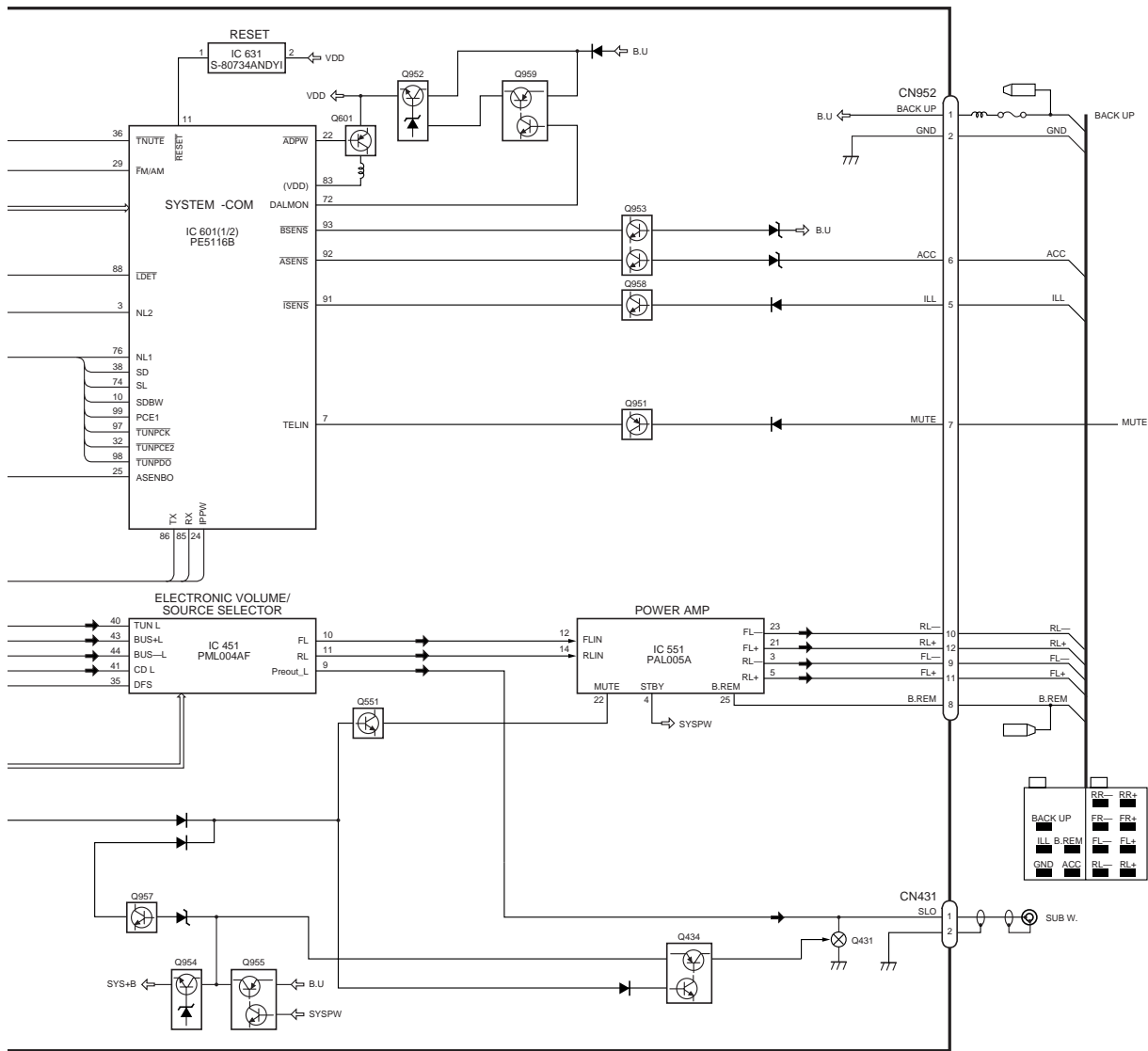

B

C

**F** PANEL PCB UNIT

**C** KEYBOARD UNIT

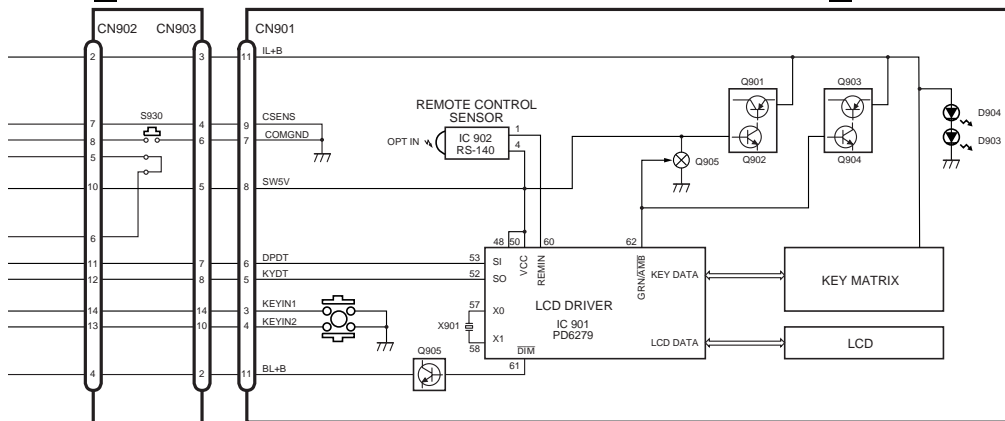

D

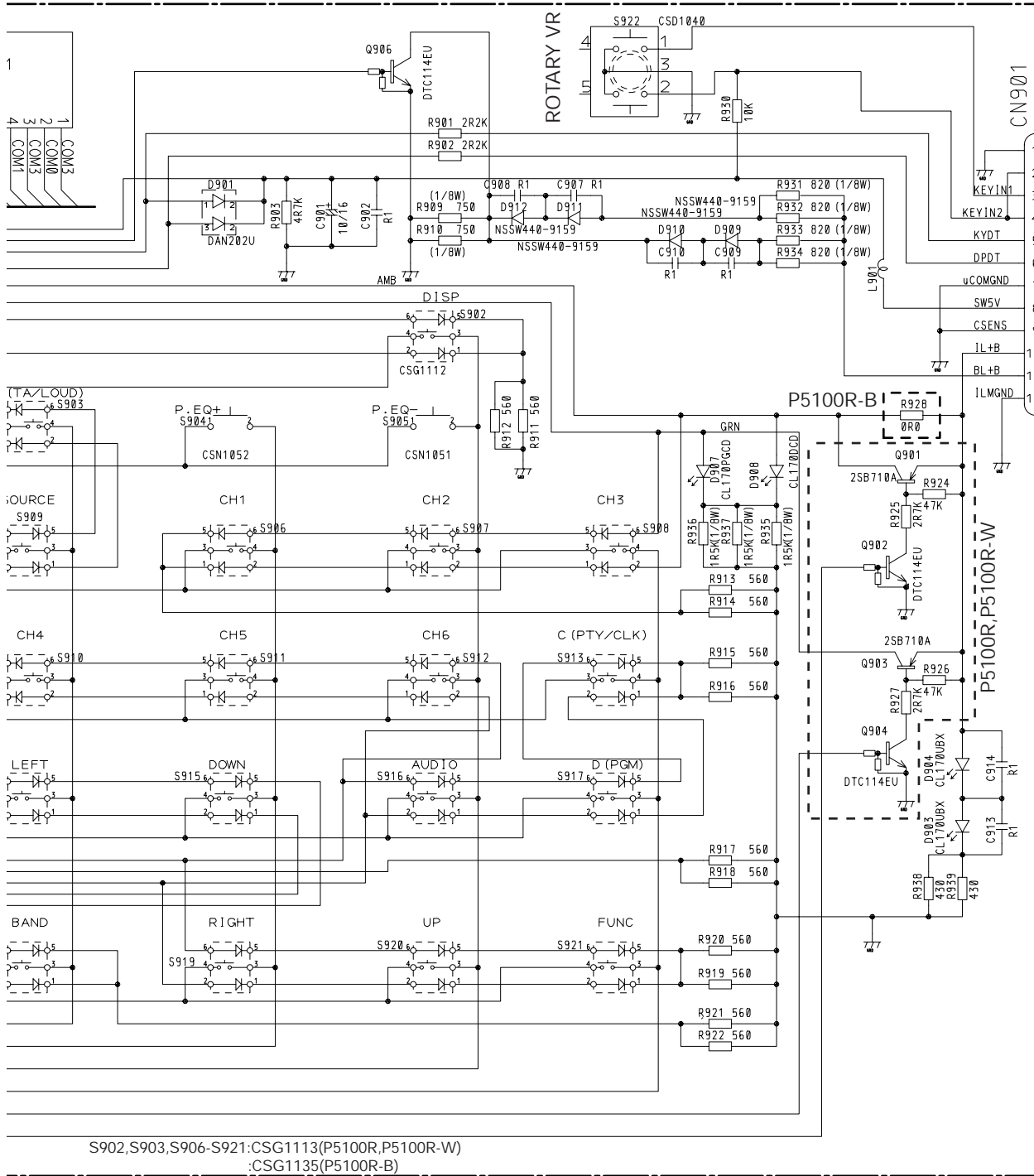

F CN903

A

B

C

D



====Circuit Symbol and No.===Part Name Part No.

**C** Unit Number : CWM6906(P5100R)  
 : CWM6910(P5100R-W)  
 Unit Name : Keyboard Unit

MISCELLANEOUS

IC	901	IC	PD6279A
IC	902	IC	RS-140
Q	901	Transistor	2SB710A
Q	902	Transistor	DTC114EU
Q	903	Transistor	2SB710A
Q	904	Transistor	DTC114EU
Q	905	Transistor	DTC114EU
Q	906	Transistor	DTC114EU
D	901	Diode	DAN202U
D	902	Diode	DAP202U
D	903	LED	CL170UBX
D	904	LED	CL170UBX
D	907	LED	CL170PGCD(AB)
D	908	LED	CL170DCD
D	909	LED	NSSW440-9159
D	910	LED	NSSW440-9159
D	911	LED	NSSW440-9159
D	912	LED	NSSW440-9159
L	901	Inductor	LCTA101J3225
X	901	Radiator 5.00MHz	CSS1423
S	902	Push Switch	CSG1113
S	903	Push Switch	CSG1113
S	904	Spring Switch	CSN1052
S	905	Spring Switch	CSN1051
S	906	Push Switch	CSG1113
S	907	Push Switch	CSG1113
S	908	Push Switch	CSG1113
S	909	Push Switch	CSG1113
S	910	Push Switch	CSG1113
S	911	Push Switch	CSG1113
S	912	Push Switch	CSG1113
S	913	Push Switch	CSG1113
S	914	Push Switch	CSG1113
S	915	Push Switch	CSG1113
S	916	Push Switch	CSG1113
S	917	Push Switch	CSG1113
S	918	Push Switch	CSG1113
S	919	Push Switch	CSG1113
S	920	Push Switch	CSG1113
S	921	Push Switch	CSG1113
S	922	Switch	CSD1040
LCD	901	LCD(P5100R)	CAW1566
LCD	901	LCD(P5100R-W)	CAW1573

RESISTORS

R	901	RS1/10S222J
R	902	RS1/10S222J
R	903	RS1/10S472J
R	904	RS1/10S121J
R	905	RS1/10S2R2J
R	906	RS1/10S470J
R	907	RS1/10S470J
R	908	RS1/10S472J
R	909	RS1/8S751J
R	910	RS1/8S751J
R	911	RS1/8S561J
R	912	RS1/8S561J
R	913	RS1/8S561J
R	914	RS1/8S561J
R	915	RS1/8S561J

====Circuit Symbol and No.===Part Name Part No.

R	916	RS1/8S561J
R	917	RS1/8S561J
R	918	RS1/8S561J
R	919	RS1/8S561J
R	920	RS1/8S561J

R	921	RS1/8S561J
R	922	RS1/8S561J
R	924	RS1/10S473J
R	925	RS1/10S272J
R	926	RS1/10S473J

R	927	RS1/10S272J
R	930	RS1/10S103J
R	931	RS1/8S821J
R	932	RS1/8S821J
R	933	RS1/8S821J

R	934	RS1/8S821J
R	935	RS1/8S152J
R	936	RS1/8S152J
R	937	RS1/8S152J
R	938	RS1/10S431J

R	939	RS1/10S431J
---	-----	-------------

CAPACITORS

C	901	CSZSR100M16
C	902	CKSQYB104K50
C	903	CSZSR100M16
C	904	CKSQYB103K50
C	905	CKSQYB103K50

C	906	CKSQYB103K50
C	907	CKSQYB104K50
C	908	CKSQYB104K50
C	909	CKSQYB104K50
C	910	CKSQYB104K50

C	913	CKSQYB104K50
C	914	CKSQYB104K50

**C** Unit Number : CWM6907(P5100R-B)  
 Unit Name : Keyboard Unit

MISCELLANEOUS

IC	901	IC	PD6279A
IC	902	IC	RS-140
Q	906	Transistor	DTC114EU
D	901	Diode	DAN202U
D	902	Diode	DAP202U

D	903	LED	CL170UBX
D	904	LED	CL170UBX
D	908	LED	CL170SRCD
D	909	LED	NSSW440-9159
D	910	LED	NSSW440-9159

D	911	LED	NSSW440-9159
D	912	LED	NSSW440-9159
L	901	Inductor	LCTA101J3225
X	901	Radiator 5.00MHz	CSS1423
S	902	Push Switch	CSG1135

S	903	Push Switch	CSG1135
S	904	Spring Switch	CSN1052
S	905	Spring Switch	CSN1051
S	906	Push Switch	CSG1135
S	907	Push Switch	CSG1135

S	908	Push Switch	CSG1135
S	909	Push Switch	CSG1135
S	910	Push Switch	CSG1135
S	911	Push Switch	CSG1135
S	912	Push Switch	CSG1135

## (4) Display of Operational Status (CPOINT) during Setup

Status No.	Contents	Protective action
00	CD+5V ON process in progress.	None
01	Servo LSI initialization (1/3) in progress.	None
02	Servo LSI CRAM initialization in progress.	None
03	Servo LSI initialization (2/3) in progress.	None
04	Offset adjustment (1/3) in progress.	None
05	Offset adjustment (2/3) in progress.	None
06	Offset adjustment (3/3) in progress.	None
07	FZD adjustment in progress.	None
08	Servo LSI initialization (3/3) in progress.	None
10	Carriage move to home position started.	None
11	Carriage move to home position started.	None
12	Carriage is moving toward inner diameter.	Specified 10 seconds has been passed or failure on home switch.
13	Carriage is moving toward outer diameter.	Specified 10 seconds has been passed or failure on home switch.
14	Carriage outer kick in progress.	None
15	Carriage outer diameter feed (1 second) in progress.	None
20	Servo close started.	None
21	Pre-processing for focus search started.	None
22	Spindle rotation and focus search started.	None
23	Waiting for focus close (XSI=Low).	Specified focus search time has been passed.
24	Standing by after focus close is over.	Specified focus search time has been passed.
25	Focus search preprocessing is in progress while setup protection is turned on.	None
26	Focus search preprocessing is in progress while focus recovery is turned on.	None
27	Wait time after focus close is set up.	Off focus.
28	Standing by after focus close is over.	Off focus.
29	Setup (1/2) before T balance adjustment is started.	Off focus.
30	Setup (2/2) before T balance adjustment is started.	Off focus.
31	T balance adjustment started.	Off focus.
32	T balance adjustment (1/2).	Off focus.
33	T balance adjustment (2/2).	Off focus.
34	Waiting for spindle rotation to end. Spindle rough servo.	Off focus.
35	Standing by after spindle rough servo is over.	Off focus.
36	RF AGC started.	Off focus.
37	RF AGC started.	Off focus.
38	RF AGC ending process in progress.	Off focus.
39	Tracking close in progress.	Off focus.
40	Standing by after tracking is closed. Carriage closing in progress.	Off focus.
41	Focus/tracking AGC started.	Off focus.
42	Focus AGC started.	Off focus.
43	Focus AGC in progress.	Off focus.
44	Tracking AGC in progress.	Off focus.
45	Standing by after focus/tracking AGC are over.	Off focus.
46	Spindle processes applicable servo.	Off focus.
47	Check for servo close is started.	Off focus.
48	Check of LOCK pin started.	Off focus or spindle not locked.
49	RF AGC started.	Off focus.
50	RF AGC in progress.	Off focus.
51	Standing by after RF AGC is over.	Off focus.

Pin No.	Pin Name	I/O	Function and Operation
59	CDLOAD	O	CD LOAD motor loading control output
60	LOCK	I	CD spindle lock detector input
61	FOK	I	CD focus OK signal input
62	PCL	O	Clock adjustment output
63	MIRR	I	CD mirror detection input
64	CLAMP	I	CD disc clamp input
65	X $\overline{\text{SCK}}$	O	CD LSI clock output
66	XSI	I	CD LSI data input
67	XSO	O	CD LSI data output
68	XA0	O	CD LSI command / data control output
69	X $\overline{\text{RST}}$	O	CD LSI reset control output
70	X $\overline{\text{STB}}$	O	CD LSI strobe output
71,72	NC		Not used
73	TEST(GND)	I	GND
74	SL	I	Signal level input
75	E $\overline{\text{JECT}}$	I	Eject sense input
76	NL1	I	RDS noise level input 1 (A/D)
77	FLPILM	I	Flap illumination input
78	EJTSNS	I	CD disc EJECT position detect input
79	DSCSNS	I	CD disc insert sense input
80	VDSNS	I	VD voltage sense input
81	TEMP	I	Temperature sense input (CD)
82	VDD		A/D converter power supply terminal
83	VDD		A/D converter reference voltage terminal
84	GND		GND
85	RX	I	IP BUS data input
86	TX	O	IP BUS data output
87	GND		GND
88	L $\overline{\text{DET}}$	I	PLL lock sense input
89	R $\overline{\text{CK}}$	I	RDS clock input
90	RDS57K	I	RDS 57kHz pulse count input
91	I $\overline{\text{SENS}}$	I	Illumination sense input
92	A $\overline{\text{SENS}}$	I	ACC power sense input
93	B $\overline{\text{SENS}}$	I	Back up power sense input
94	TUNPDI	I	PLL IC data input
95	KYDT	I	Grille data input
96	DPDT	O	Grille data output
97	TUNPCK	O	PLL IC clock output
98	TUNPDO	O	PLL IC data output
99	TUNPCE	O	PLL IC chip enable output
100	PEE	O	Beep tone output

\*PE5116B

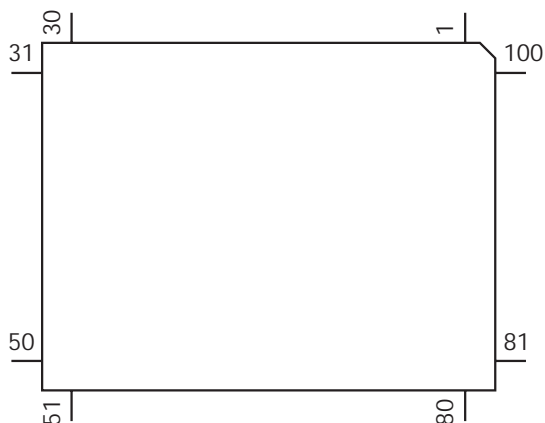

CLICK HERE TO **DOWNLOAD** THE COMPLETE MANUAL

- Thank you very much for reading the preview of the manual.
- You can download the complete manual from: [www.heydownloads.com](http://www.heydownloads.com) by clicking the link below



- Please note: If there is no response to CLICKING the link, please download this PDF first and then click on it.

CLICK HERE TO **DOWNLOAD** THE COMPLETE MANUAL