

Edition: July 2004
Revision: July 2005
Publication No. SM5E-1B15U1

NISSAN SENTRA

MODEL B15 SERIES

QUICK REFERENCE INDEX

A GENERAL INFORMATION	GI General Information
B ENGINE	EM Engine Mechanical
	LU Engine Lubrication System
	CO Engine Cooling System
	EC Engine Control System
	FL Fuel System
	EX Exhaust System
	ACC Accelerator Control System
C TRANSMISSION/ TRANSAXLE	CL Clutch
	MT Manual Transaxle
	AT Automatic Transaxle
D DRIVELINE/AXLE	FAX Front Axle
	RAX Rear Axle
E SUSPENSION	FSU Front Suspension
	RSU Rear Suspension
	WT Road Wheels & Tires
F BRAKES	BR Brake System
	PB Parking Brake System
	BRC Brake Control System
G STEERING	PS Power Steering System
H RESTRAINTS	SB Seat Belts
	SRS Supplemental Restraint System (SRS)
	BL Body, Lock & Security System
	GW Glasses, Window System & Mirrors
	RF Roof
I BODY	EI Exterior & Interior
	IP Instrument Panel
	SE Seat
	MTC Manual Air Conditioner
	SC Starting & Charging System
	LT Lighting System
J AIR CONDITIONER	DI Driver Information System
	WW Wiper, Washer & Horn
	BCS Body Control System
	LAN LAN System
	AV Audio Visual, Navigation & Telephone System
	ACS Auto Cruise Control System
	PG Power Supply, Ground & Circuit Elements
	MA Maintenance
	IDX Alphabetical Index
	L MAINTENANCE
M INDEX	

A
B
C
D
E
F
G
H
I
J
K
L
M

CLICK HERE TO **DOWNLOAD** THE COMPLETE MANUAL

- Thank you very much for reading the preview of the manual.
- You can download the complete manual from: www.heydownloads.com by clicking the link below



- Please note: If there is no response to CLICKING the link, please download this PDF first and then click on it.

CLICK HERE TO **DOWNLOAD** THE COMPLETE MANUAL

OVERALL SYSTEM

[RE4F03B]

Cross-sectional View

ECS005W4

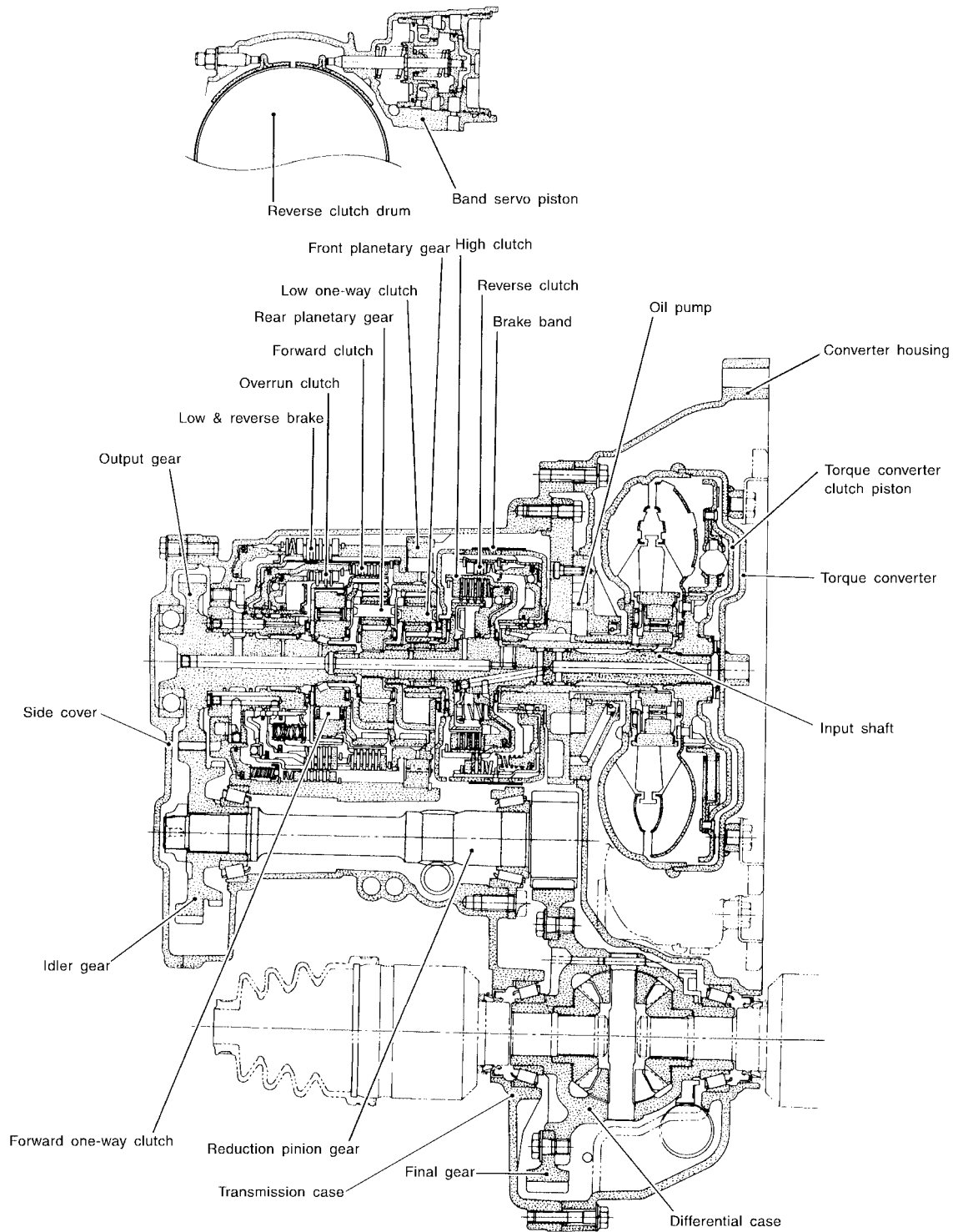

A
B
AT
D
E
F
G
H
I
J
K
L
M

SAT842J

Judgement of Self-diagnosis Code

O/D OFF indicator lamp:

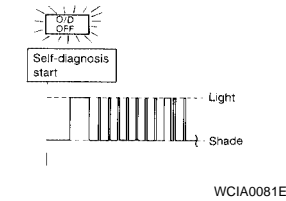
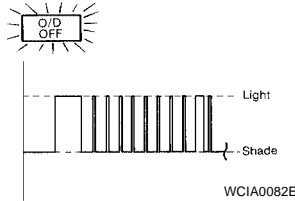
<p>All judgement flickers are the same.</p>  <p>All circuits that can be confirmed by self-diagnosis are OK.</p>	<p>1st judgement flicker is longer than others.</p>  <p>Revolution sensor circuit is short-circuited or disconnected. ⇒ Go to AT-126, "DTC P0720 VEHICLE SPEED SENSOR-A/T (REVOLUTION SENSOR)".</p>
<p>2nd judgement flicker is longer than others.</p>  <p>Vehicle speed sensor circuit is short-circuited or disconnected. ⇒ Go to AT-203, "DTC VHCL SPEED SEN-MTR VEHICLE SPEED SENSOR-MTR".</p>	<p>3rd judgement flicker is longer than others.</p>  <p>Throttle position sensor [accelerator pedal position (APP) sensor] circuit is short-circuited or disconnected. ⇒ Go to AT-187, "DTC P1705 THROTTLE POSITION SENSOR [ACCELERATOR PEDAL POSITION (APP) SENSOR]".</p>
<p>4th judgement flicker is longer than others.</p>  <p>Shift solenoid valve A circuit is short-circuited or disconnected. ⇒ Go to AT-179, "DTC P0750 SHIFT SOLENOID VALVE A".</p>	<p>5th judgement flicker is longer than others.</p>  <p>Shift solenoid valve B circuit is short-circuited or disconnected. ⇒ Go to AT-183, "DTC P0755 SHIFT SOLENOID VALVE B".</p>
<p>6th judgement flicker is longer than others.</p>  <p>Overrun clutch solenoid valve circuit is short-circuited or disconnected. ⇒ Go to AT-193, "DTC P1760 OVERRUN CLUTCH SOLENOID VALVE".</p>	<p>7th judgement flicker is longer than others.</p>  <p>Torque converter clutch solenoid valve circuit is short-circuited or disconnected. ⇒ Go to AT-159, "DTC P0740 TORQUE CONVERTER CLUTCH SOLENOID VALVE".</p>
<p>8th judgement flicker is longer than others.</p>  <p>A/T fluid temperature sensor is disconnected or TCM power source circuit is damaged. ⇒ Go to AT-197, "DTC BATT/FLUID TEMP SEN (A/T FLUID TEMP SENSOR CIRCUIT AND TCM POWER SOURCE)".</p>	<p>9th judgement flicker is longer than others.</p>  <p>Engine speed signal circuit is short-circuited or disconnected. ⇒ Go to AT-131, "DTC P0725 ENGINE SPEED SIGNAL".</p>

TROUBLE DIAGNOSIS — GENERAL DESCRIPTION

[RE4F03B]

Items	Symptom	Condition	Diagnostic Item	Reference Page	
				QG18DE (SULEV)	QG18DE (ULEV)
Slips/Will Not Engage	No creep at all. AT-226, "6. Vehicle Does Not Creep Backward In "R" Position" , AT-228, "7. Vehicle Does Not Creep Forward In "D", "2" Or "1" Position"	ON vehicle	1. Fluid level	AT-63, "FLUID LEVEL CHECK"	
			2. Line pressure test	AT-67, "Line Pressure Test"	
			3. Control valve assembly	AT-297, "CONTROL VALVE ASSEMBLY"	
		OFF vehicle	4. Forward clutch	AT-324, "FORWARD CLUTCH AND OVER-RUN CLUTCH"	
			5. Oil pump	AT-292, "OIL PUMP"	
			6. Torque converter	AT-267, "Components"	
No Up Shift	Failure to change gear from "D1" to "D2".	ON vehicle	1. Control cable adjustment	AT-262, "Control Cable Adjustment"	
			2. Shift solenoid valve A	AT-179, "DTC P0750 SHIFT SOLENOID VALVE A"	
			3. Control valve assembly	AT-297, "CONTROL VALVE ASSEMBLY"	
			4. Vehicle speed sensor-A/T (Revolution sensor) and vehicle speed sensor-MTR	AT-126, "DTC P0720 VEHICLE SPEED SENSOR-A/T (REVOLUTION SENSOR)" , AT-203, "DTC VHCL SPEED SEN-MTR VEHICLE SPEED SENSOR-MTR"	
			5. Throttle position sensor [accelerator pedal position (APP) sensor]	AT-187, "DTC P1705 THROTTLE POSITION SENSOR [ACCELERATOR PEDAL POSITION (APP) SENSOR]"	
		OFF vehicle	6. Brake band	AT-348, "Components"	

A

B

AT

D

E

F

G

H

I

J

K

L

M

3. CHECK INPUT SIGNAL OF A/T FLUID TEMPERATURE SENSOR (WITHOUT CONSULT-II)

⊗ **Without CONSULT-II**

1. Start engine.
2. Check voltage between TCM terminal 47 and ground while warming up A/T.

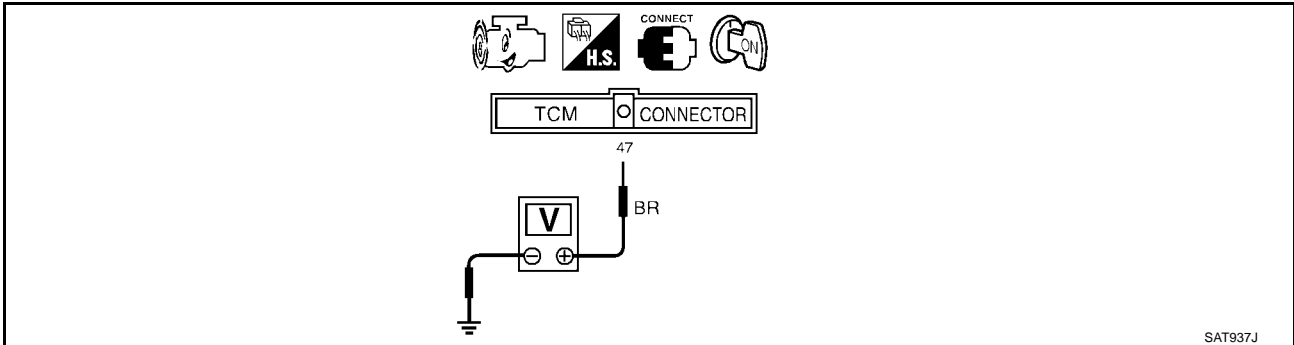

Voltage

Cold [20°C (68°F)] → : Approximately 1.5V →
Hot [80°C (176°F)] 0.5V

3. Turn ignition switch to “OFF” position.
4. Disconnect TCM harness connector.
5. Check continuity between TCM harness connector F57 terminal 42 (B/W) and ground.

Continuity should exist.

If OK, check harness for short to ground and short to power.

OK or NG

- OK >> GO TO 4.
 NG >> GO TO 5.

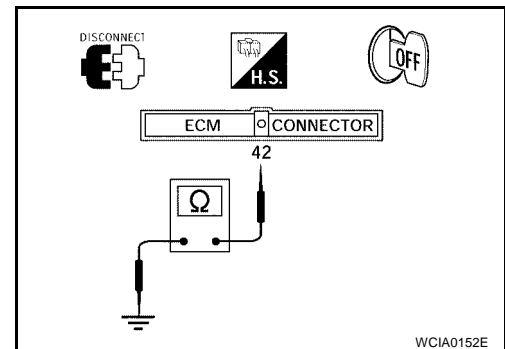

4. CHECK DTC

Perform [AT-120, "DTC P0710 A/T FLUID TEMPERATURE SENSOR CIRCUIT"](#) .

OK or NG

- OK >> **INSPECTION END**
 NG >> 1. Perform TCM input/output signal inspection.
 2. If NG, recheck TCM pin terminals for damage or loose connection with harness connector.

DTC P0740 TORQUE CONVERTER CLUTCH SOLENOID VALVE

[RE4F03B]

DTC P0740 TORQUE CONVERTER CLUTCH SOLENOID VALVE

PF3:31940

Description

ECS005XK

The torque converter clutch solenoid valve is activated, with the gear in "D4", by the TCM in response to signals sent from the vehicle speed sensor and throttle position sensor [accelerator pedal position (APP) sensor]s. Lock-up piston operation will then be controlled.

Lock-up operation, however, is prohibited when A/T fluid temperature is too low.

When the accelerator pedal is depressed (less than 2/8) in lock-up condition, the engine speed should not change abruptly. If there is a big jump in engine speed, there is no lock-up.

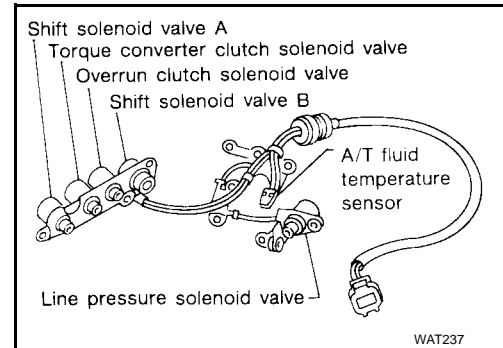

CONSULT-II REFERENCE VALUE IN DATA MONITOR MODE

Remarks: Specification data are reference values.

Monitor item	Condition	Specification (Approx.)
Torque converter clutch solenoid valve duty	Lock-up "OFF"	4%
	↓ Lock-up "ON"	↓ 94%

ON BOARD DIAGNOSIS LOGIC

Diagnostic trouble code	Malfunction is detected when...	Check items (Possible cause)
: TCC SOLENOID/CIRC : P0740	TCM detects an improper voltage drop when it tries to operate the solenoid valve.	<ul style="list-style-type: none"> • Harness or connectors (The solenoid circuit is open or shorted.) • T/C clutch solenoid valve

DIAGNOSTIC TROUBLE CODE (DTC) CONFIRMATION PROCEDURE

NOTE:

If "DIAGNOSTIC TROUBLE CODE CONFIRMATION PROCEDURE" has been previously conducted, always turn ignition switch "OFF" and wait at least 5 seconds before conducting the next test.

After the repair, perform the following procedure to confirm the malfunction is eliminated.

With CONSULT-II

1. Turn ignition switch "ON".

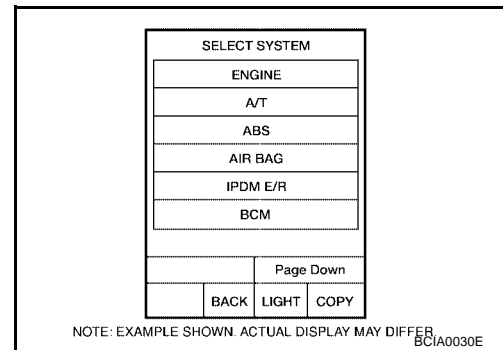

2. Select "DATA MONITOR" mode for "ENGINE" with CONSULT-II and wait at least 1 second.

With GST

Follow the procedure "With CONSULT-II".

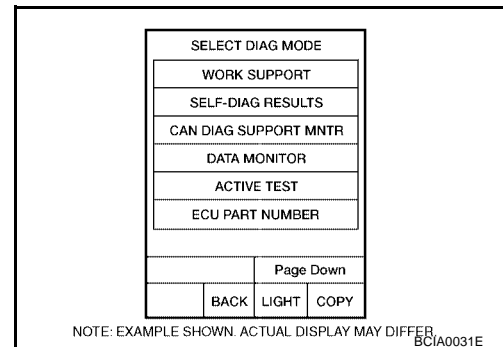

DTC P1760 OVERRUN CLUTCH SOLENOID VALVE

[RE4F03B]

ECS005Y9

Wiring Diagram — AT — OVRCSV

AT-OVRCSV-01

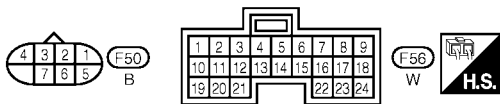
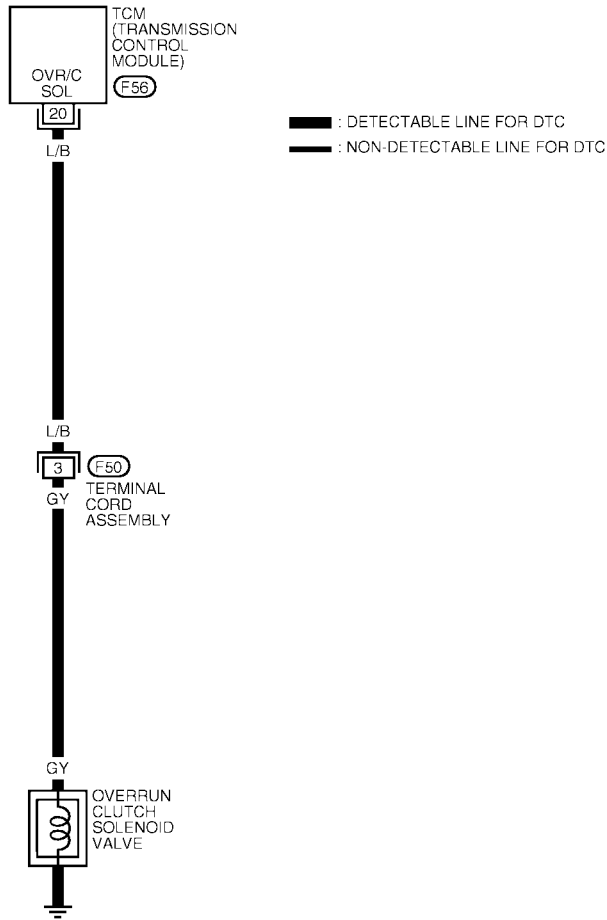

WAT128

TRANSMISSION CONTROL MODULE TERMINALS AND REFERENCE VALUE BETWEEN TERMINAL AND GROUND

TERMINAL	WIRE COLOR	ITEM	CONDITION	DATA (DC) (Approx.)
20	L/B	OVERRUN CLUTCH SOLENOID VALVE	WHEN OVERRUN CLUTCH SOLENOID VALVE OPERATES	BATTERY VOLTAGE
			WHEN OVERRUN CLUTCH SOLENOID VALVE DOES NOT OPERATE	0V

WAT351

4. CHECK A/T FLUID CONDITION

1. Remove oil pan.
2. Check A/T fluid condition.

OK or NG

- OK >> GO TO 5.
 NG >> GO TO 6.

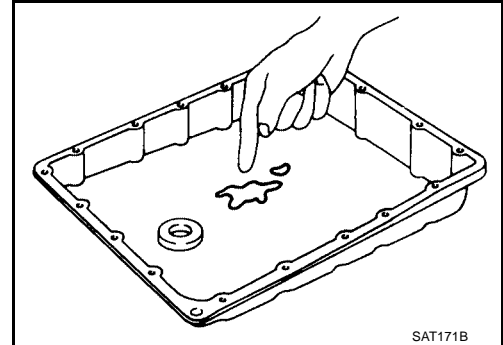
**5. CHECK SYMPTOM**

Check again.

OK or NG

- OK >> **INSPECTION END**
 NG >> 1. Perform TCM input/output signal inspection.
 2. If NG, recheck TCM pin terminals for damage or loose connection with harness connector.

6. DETECT MALFUNCTIONING ITEM

1. Disassemble A/T.
2. Check the following items:
 - Forward clutch assembly
 - Forward one-way clutch
 - Low one-way clutch
 - Reverse clutch assembly
 - High clutch assembly

OK or NG

- OK >> GO TO 5.
 NG >> Repair or replace damaged parts.

A
 B
 AT
 D
 E
 F
 G
 H
 I
 J
 K
 L
 M

REMOVAL AND INSTALLATION

Removal

CAUTION:

Before separating transaxle from engine, remove the crankshaft position sensor (OBD) from transaxle. Be careful not to damage sensor.

1. Remove battery and bracket.
2. Remove air duct between throttle body and air cleaner.
3. Disconnect terminal cord assembly, PNP switch harness connector and revolution sensor harness connector.

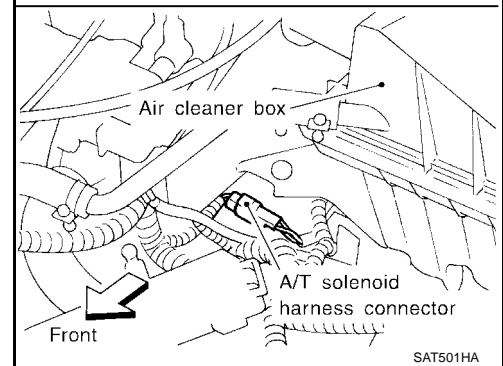
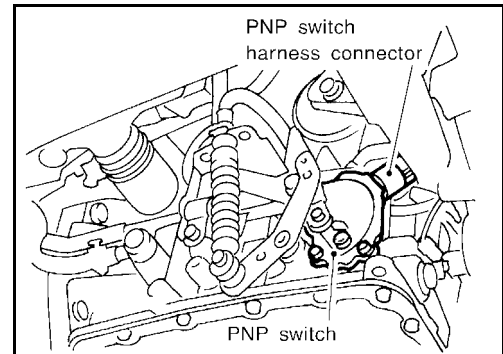

4. Drain ATF from transaxle.
5. Disconnect control cable from transaxle.
6. Disconnect oil cooler hoses.
7. Remove drive shafts. Refer to [FAX-14, "Removal"](#) .
8. Remove the intake manifold support bracket. Refer to [EM-15, "Removal and Installation"](#) .
9. Remove starter motor from transaxle.

Tighten bolts to specified torque.

 : 33.3 - 46.1 N·m (3.4 - 4.7 kg·m, 25 - 34 ft·lb)

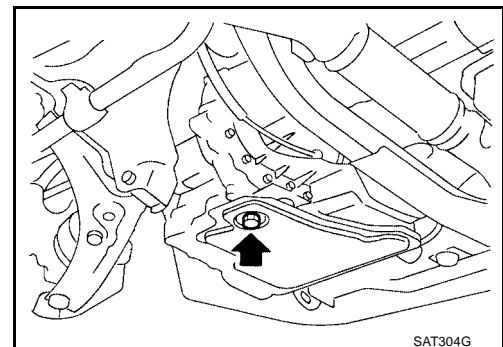

10. Remove upper bolts fixing transaxle to engine.
11. Support transaxle with a jack.
12. Remove center member.
 - Tighten center member fixing bolts to specified torque, Refer to [EM-68, "INSTALLATION"](#) .

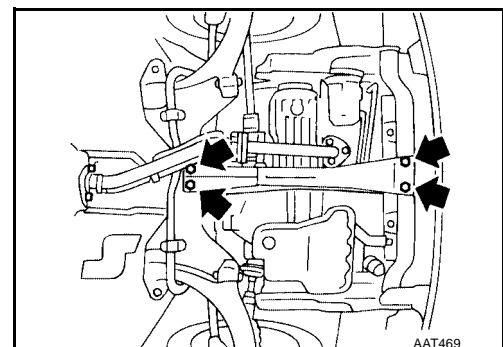

CONTROL VALVE ASSEMBLY

[RE4F03B]

3. Remove O-rings from solenoid valves and terminal body.

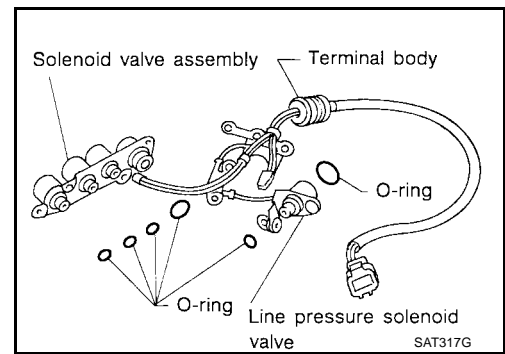

4. Place upper body face down, and remove bolts B, C and F.

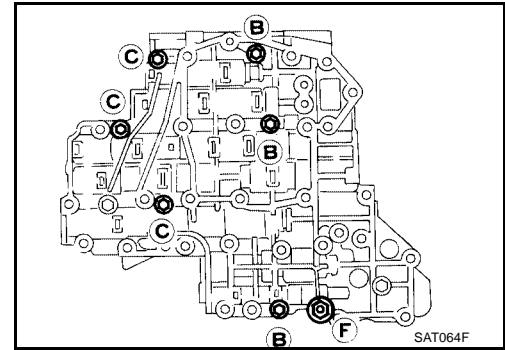

5. Remove lower body from inter body.

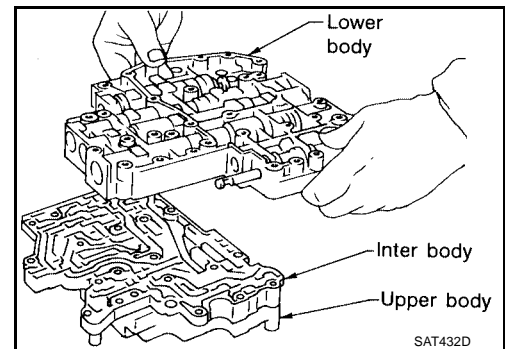

6. Turn over lower body, and accumulator support plates.

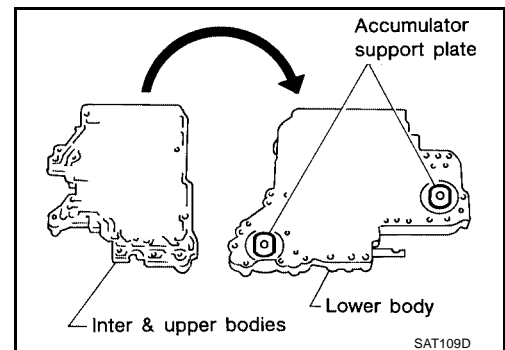

A
B
AT
D
E
F
G
H
I
J
K
L
M

- Remove D-ring and oil seal from piston.

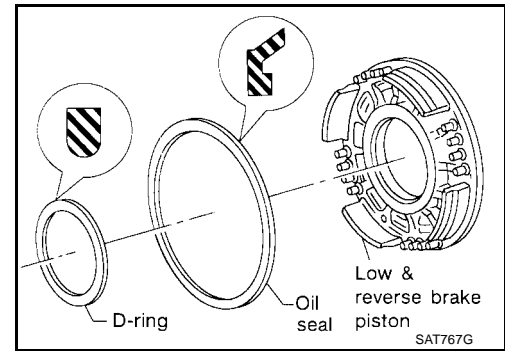

Inspection

LOW & REVERSE CLUTCH SNAP RING, SPRING RETAINER AND RETURN SPRINGS

ECS0060P

- Check for deformation, fatigue or damage.
- Replace if necessary.
- When replacing spring retainer and return springs, replace them as a set.**

LOW & REVERSE BRAKE DRIVE PLATES

- Check facing for burns, cracks or damage.
- Measure thickness of facing.

Thickness of drive plate

Standard value : 2.0 mm (0.079 in)

Wear limit : 1.8 mm (0.071 in)

- If not within wear limit, replace.

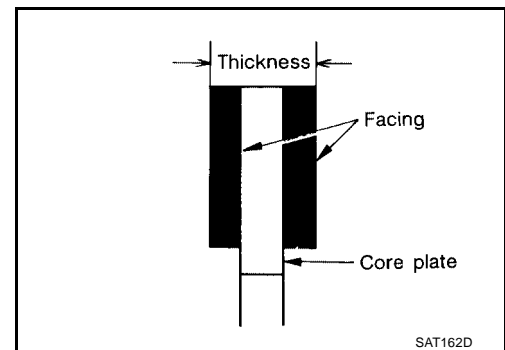

ECS0060P

Assembly

- Install D-ring and oil seal on piston.
 - Take care with the direction of the oil seal.
 - Apply ATF to both parts.

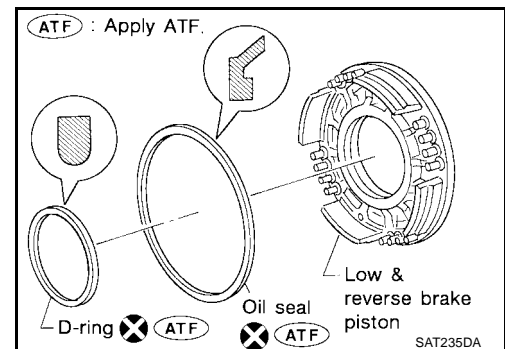

- Stand transmission case.
- Install piston assembly on transmission case while turning it slowly.
 - Apply ATF to inner surface of transmission case.

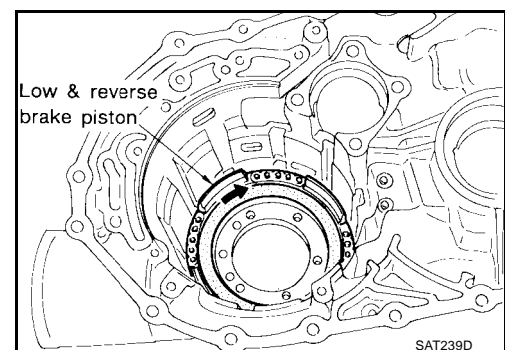

ASSEMBLY

[RE4F03B]

6. Hold forward clutch hub and turn overrun clutch hub.
Check overrun clutch hub for directions of lock and unlock.
- If not as shown in illustration, check installed direction of forward one-way clutch.

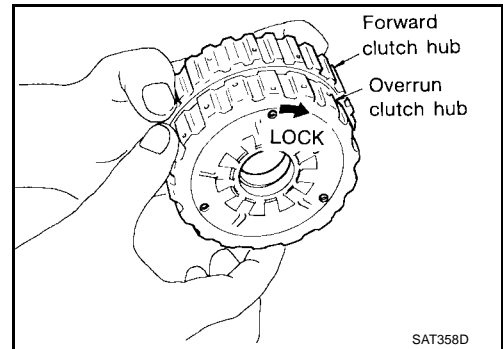

7. Install rear internal gear assembly.
- **Align teeth of forward clutch and overrun clutch drive plate.**

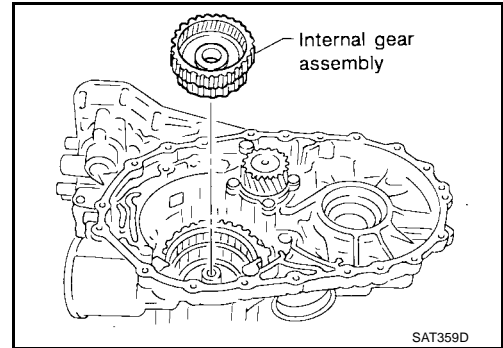

8. Install needle bearing on rear planetary carrier.
- **Apply petroleum jelly to needle bearing.**
 - **Pay attention to direction of needle bearing.**

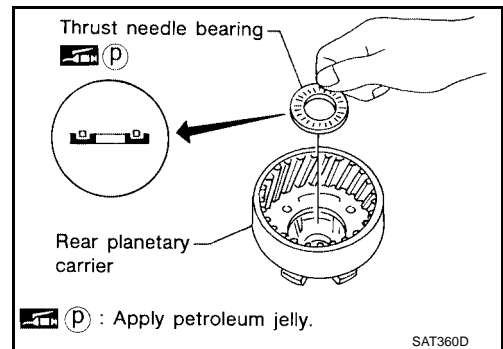

9. Install rear sun gear on rear planetary carrier.
- **Pay attention to direction of rear sun gear.**

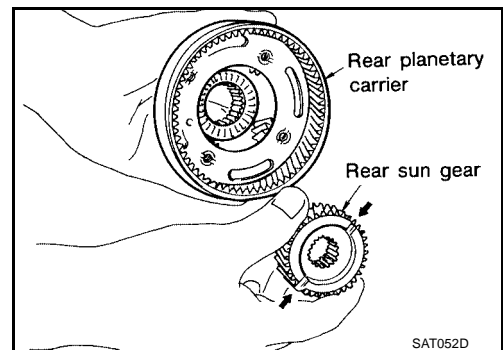

A
B
AT
D
E
F
G
H
I
J
K
L
M

PREPARATION

[RE4F04B]

ECS00628

Commercial Service Tools

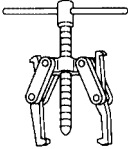
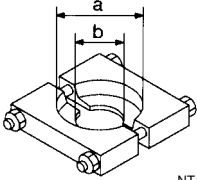
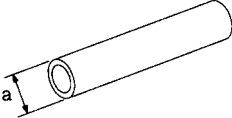
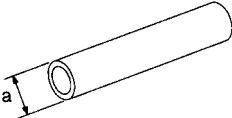
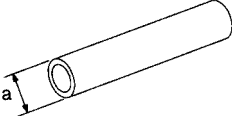
Tool name	Description
Puller  NT077	<ul style="list-style-type: none"> ● Removing idler gear bearing inner race ● Removing and installing band servo piston snap ring
Puller  NT411	<ul style="list-style-type: none"> ● Removing reduction gear bearing inner race <p>a: 60 mm (2.36 in) dia. b: 35 mm (1.38 in) dia.</p>
Drift  NT083	<ul style="list-style-type: none"> ● Installing needle bearing on bearing retainer <p>a: 36 mm (1.42 in) dia.</p>
Drift  NT083	<ul style="list-style-type: none"> ● Removing needle bearing from bearing retainer <p>a: 33.5 mm (1.319 in) dia.</p>
Drift  NT083	<ul style="list-style-type: none"> ● Installing differential side bearing outer race (RH side) <p>a: 75 mm (2.95 in) dia.</p>

NO TOOLS OBD-II SELF-DIAGNOSTIC PROCEDURE (NO TOOLS)

Refer to [EC-714, "Malfunction Indicator Lamp \(MIL\)"](#) .

NO TOOLS TCM SELF-DIAGNOSTIC PROCEDURE (NO TOOLS)

1. CHECK O/D OFF INDICATOR LAMP

1. Move selector lever to P position.
Start engine and warm it up to normal engine operating temperature.
2. Turn ignition switch to OFF position.
3. Wait 5 seconds.
4. Turn ignition switch to ON position.
(Do not start engine.)

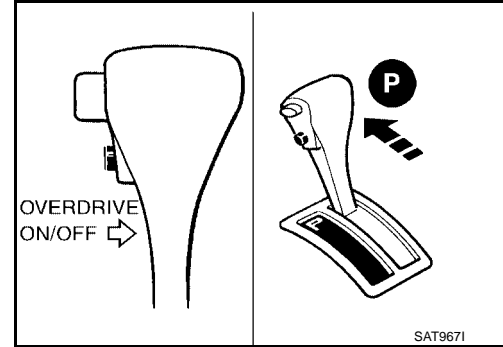

5. Does O/D OFF indicator lamp come on for about 2 seconds?

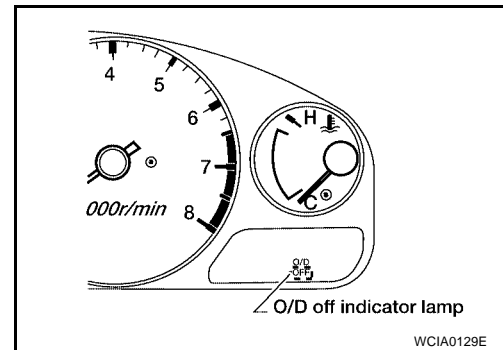

Yes or No

- Yes >> GO TO 2.
 No >> Stop procedure. Perform [AT-597, "1. O/D OFF Indicator Lamp Does Not Come On"](#) before proceeding.

A
B
AT
D
E
F
G
H
I
J
K
L
M

TROUBLE DIAGNOSIS - GENERAL DESCRIPTION

[RE4F04B]

Items	Symptom	Condition	Diagnostic Item	Reference Page
No Up Shift	A/T does not shift to D4 when driving with overdrive control switch ON.	ON vehicle	1. Throttle position sensor [accelerator pedal position (APP) sensor]	AT-559
			2. Park/neutral position (PNP) switch adjustment	AT-641
			3. Overdrive control switch	AT-627
			4. Vehicle speed sensor-A/T (Revolution sensor) and vehicle speed sensor-MTR	AT-499 , AT-576
			5. Shift solenoid valve A	AT-549
			6. Overrun clutch solenoid valve	AT-564
			7. Control valve assembly	AT-639
			8. A/T fluid temperature sensor	AT-569
			9. Line pressure solenoid valve	AT-543
		OFF vehicle	10. Brake band	AT-652
			11. Overrun clutch	AT-697
Slips/Will Not Engage	Vehicle will not run in R position (but runs in D, 2 and 1 positions). Clutch slips. Very poor acceleration. AT-604	ON vehicle	1. Control cable adjustment	AT-642
			2. Line pressure test	AT-453
			3. Stall test	AT-449
			4. Line pressure solenoid valve	AT-543
			5. Control valve assembly	AT-639
		OFF vehicle	6. Reverse clutch	AT-689
			7. High clutch	AT-692
			8. Forward clutch	AT-697
			9. Overrun clutch	AT-697
			10. Low & reverse brake	AT-703
Vehicle will not run in D and 2 positions (but runs in 1 and R positions).	ON vehicle	1. Control cable adjustment	AT-642	
	OFF vehicle	2. Low one-way clutch	AT-652	
Slips/Will Not Engage	Vehicle will not run in D, 1, 2 positions (but runs in R position). Clutch slips. Very poor acceleration. AT-607	ON vehicle	1. Fluid level	AT-449
			2. Stall test	AT-449
			3. Line pressure test	AT-453
			4. Line pressure solenoid valve	AT-543
			5. Control valve assembly	AT-639
			6. Accumulator N-D	AT-652
		OFF vehicle	7. Reverse clutch	AT-689
			8. High clutch	AT-692
			9. Forward clutch	AT-697
			10. Forward one-way clutch	AT-652
			11. Low one-way clutch	AT-652

WITH CONSULT-II

1. Start engine and select "DATA MONITOR" mode for "A/T" with CONSULT-II.
2. Make sure that output voltage of A/T fluid temperature sensor is within the range below.
FLUID TEMP SEN: 0.4 - 1.5V
 If out of range, drive the vehicle to decrease the voltage (warm up the fluid) or stop engine to increase the voltage (cool down the fluid).
3. Select "1ST GR FNCTN P0731" of "DTC WORK SUPPORT" mode for "A/T" with CONSULT-II and touch "START".

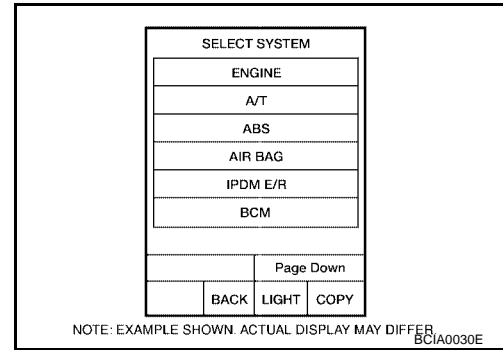

4. Accelerate vehicle to 20 to 25 km/h (12 to 16 MPH) under the following condition and release the accelerator pedal completely.

THROTTLE POSI: Less than 1.0/8 (at all times during step 4)
Selector lever: D position (O/D ON)

- Check that "GEAR" shows "2" after releasing pedal.
5. Depress accelerator pedal to WOT (more than 7.0/8 of "THROTTLE POSI") quickly from a speed of 20 to 25 km/h (12 to 16 MPH) until "TESTING" changes to "STOP VEHICLE" or "COMPLETED". (It will take approximately 3 seconds.)

If the check result NG appears on CONSULT-II screen, go to [AT-511, "Diagnostic Procedure"](#).

If "STOP VEHICLE" appears on CONSULT-II screen, go to the following step.

- Check that "GEAR" shows "1" when depressing accelerator pedal to WOT.
- If "TESTING" does not appear on CONSULT-II for a long time, select "SELF-DIAG RESULTS" for "ENGINE". In case a 1st trip DTC other than P0731 is shown, refer to applicable "TROUBLE DIAGNOSIS FOR DTC".

6. Stop vehicle.
7. Follow the instruction displayed. (Check for normal shifting referring to the table below.)

Vehicle condition	Gear on actual transmission shift pattern when screen is changed to 1 → 2 → 3 → 4
No malfunction exists.	1 → 2 → 3 → 4
Malfunction for P0731 exists.	2 → 2 → 3 → 3
	4 → 3 → 3 → 4

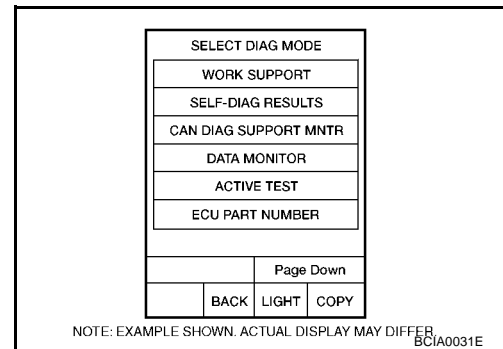

8. Make sure that "OK" is displayed. (If "NG" is displayed, refer to "DIAGNOSTIC PROCEDURE".)
 Refer to [AT-511, "Diagnostic Procedure"](#).
 Refer to [AT-747, "Shift Schedule"](#).

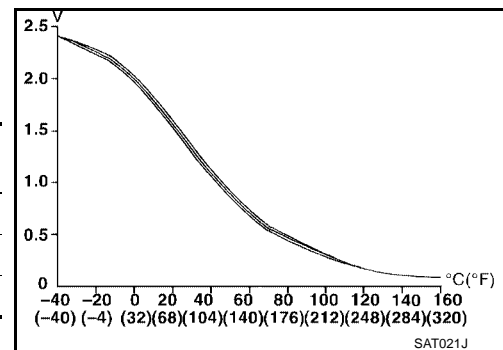

WITH GST

Follow the procedure "With CONSULT-II".

DTC P0745 LINE PRESSURE SOLENOID VALVE

[RE4F04B]

- Depress accelerator pedal completely and wait at least 5 seconds.

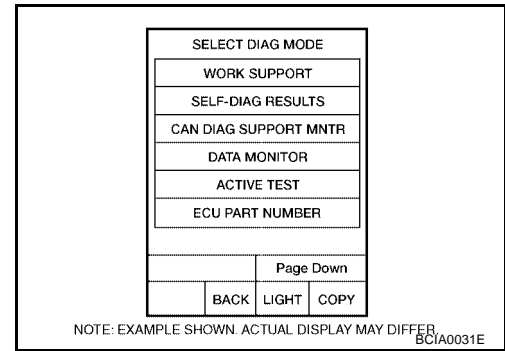

WITH GST

Follow the procedure "With CONSULT-II".

DTC VEHICLE SPEED SENSOR MTR

[RE4F04B]

TCM TERMINALS AND REFERENCE VALUE MEASURED BETWEEN EACH TERMINAL AND 25 OR 48 (TCM GROUND)

TERMINAL	WIRE COLOR	ITEM	CONDITION	DATA (DC)
40	PU/R	VEHICLE SPEED SENSOR	WHEN MOVING VEHICLE AT 2 TO 3 KM/H (1 TO 2 MPH) FOR 1 M (3 FT)	VOLTAGE VARIES BETWEEN LESS THAN 1V AND MORE THAN 4.5V

Diagnostic Procedure

ECS0065S

1. CHECK INPUT SIGNAL

With CONSULT-II

DATA MONITOR	
MONITORING	
VHCL/S SE-A/T	XXX km/h
VHCL/S SE-MTR	XXX km/h
THRTL POS SEN	XXX V
FLUID TEMP SE	XXX V
BATTERY VOLT	XXX V

SAT614J

1. Start engine.
2. Select "TCM INPUT SIGNALS" in "DATA MONITOR" mode for "A/T" with CONSULT-II.
3. Read out the value of "VHCL/S SE·MTR" while driving. Check the value changes according to driving speed.

Without CONSULT-II

1. Start engine.
2. Check voltage between TCM terminal 40 and ground while driving at 2 to 3 km/h (1 to 2 MPH) for 1 m (3 ft) or more.

Voltage :Voltage varies between less than 1V and more than 4.5V.

OK or NG

- OK >> GO TO 3.
NG >> GO TO 2.

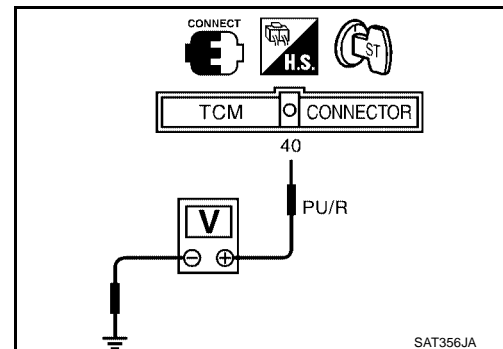

SAT356JA

2. DETECT MALFUNCTIONING ITEM

Check the following items:

- Vehicle speed sensor and ground circuit for vehicle speed sensor Refer to [DI-4, "METERS AND GAUGES"](#).
- Harness for short or open between TCM and vehicle speed sensor (Main harness)

OK or NG

- OK >> GO TO 3.
NG >> Repair or replace damaged parts.

7. DETECT MALFUNCTIONING ITEM

1. Remove control valve. Refer to [AT-639, "REMOVAL"](#) .
2. Check the following items:
 - Shift valve A
 - Shift solenoid valve A
 - Pilot valve
 - Pilot filter

OK or NG

- OK >> GO TO 8.
 NG >> Repair or replace damaged parts.

8. CHECK SYMPTOM

Check again.

OK or NG

- OK >> **INSPECTION END**
 NG >> GO TO 9.

9. CHECK TCM INSPECTION

1. Perform TCM input/output signal inspection.
2. If NG, recheck TCM pin terminals for damage or loose connection with harness connector.

OK or NG

- OK >> **INSPECTION END**
 NG >> Repair or replace damaged parts.

10. A/T Does Not Shift: D2 → D3

ECS0066K

SYMPTOM:

A/T does not shift from D2 to D3 at the specified speed.

1. CHECK SYMPTOM

Are "7. Vehicle Does Not Creep Forward In D, 2 Or 1 Position" and "8. Vehicle Cannot Be Started From D1 " OK?

Yes or No

- Yes >> GO TO 2.
 No >> Go to [AT-607, "7. Vehicle Does Not Creep Forward in D, 2 or 1 Position"](#) and [AT-609, "8. Vehicle Cannot Be Started From D1"](#) .

DISASSEMBLY

1. Remove valves at retainer plates.
 - Do not use a magnetic pick-up tool.

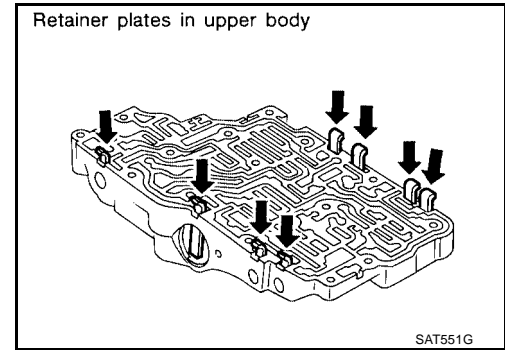

- a. Use a screwdriver to remove retainer plates.

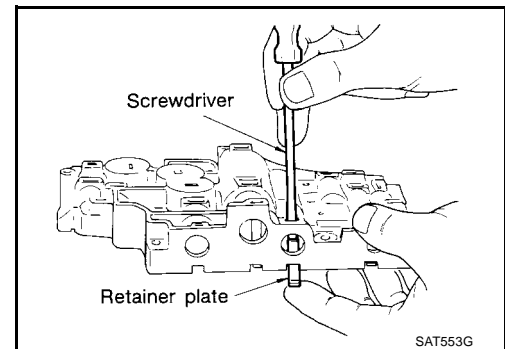

- b. Remove retainer plates while holding spring, plugs or sleeves.
 - Remove plugs slowly to prevent internal parts from jumping out.

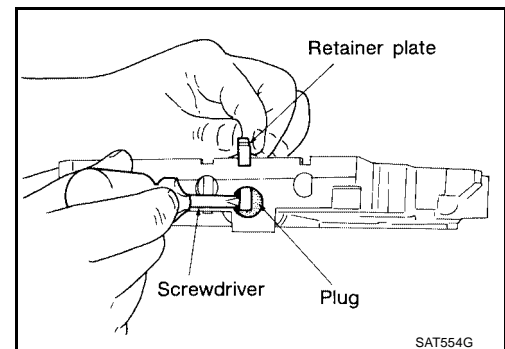

- c. Place mating surface of valve body face down, and remove internal parts.
 - If a valve is hard to remove, place valve body face down and lightly tap it with a soft hammer.
 - Be careful not to drop or damage valves and sleeves.

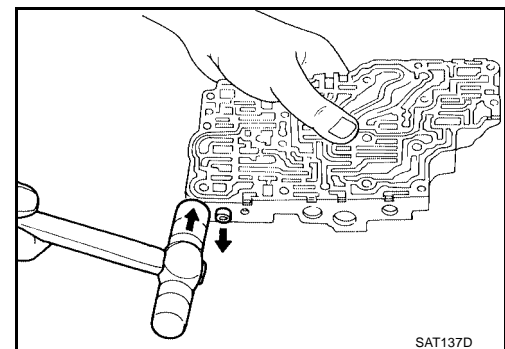

REPAIR FOR COMPONENT PARTS

[RE4F04B]

9. Install band servo piston assembly and 2nd servo return spring to transmission case.

- Apply ATF to O-ring of band servo piston and transmission case.

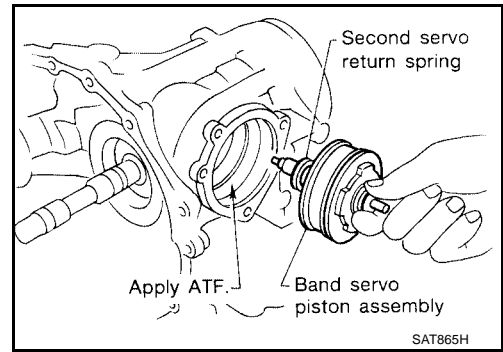

10. Install O/D servo piston assembly to transmission case.

- Apply ATF to O-ring of band servo piston and transmission case.

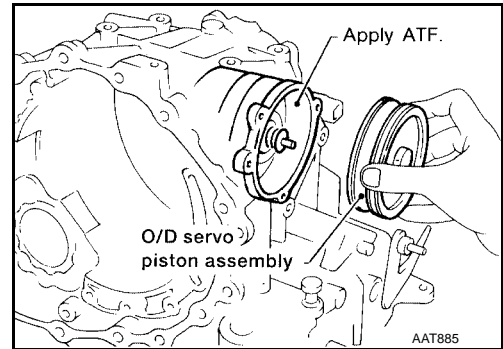

11. Install O/D servo piston retainer to transmission case. Refer to [AT-717, "ASSEMBLY"](#).

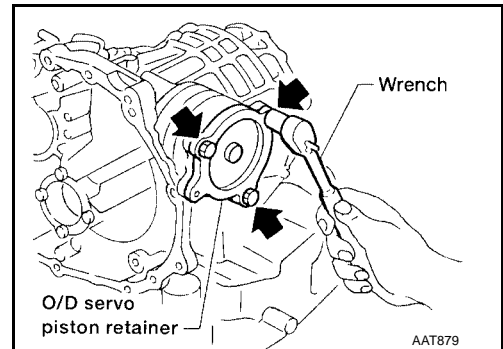

Final Drive COMPONENTS

ECS0067Q

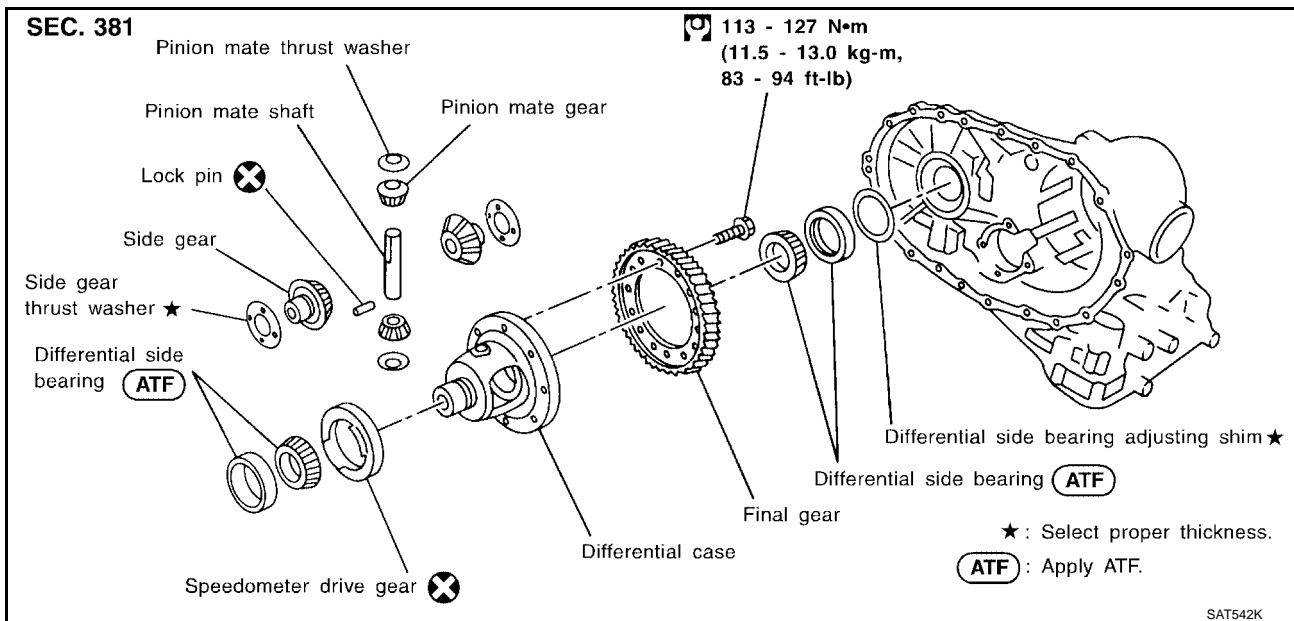

SERVICE DATA AND SPECIFICATIONS (SDS)

[RE4F04B]

OUTPUT SHAFT ADJUSTING SHIMS

Thickness mm (in)	Part number*
0.80 (0.0315)	31438-80X60
0.84 (0.0331)	31438-80X61
0.88 (0.0346)	31438-80X62
0.92 (0.0362)	31438-80X63
0.96 (0.0378)	31438-80X64
1.00 (0.0394)	31438-80X65
1.04 (0.0409)	31438-80X66
1.08 (0.0425)	31438-80X67
1.12 (0.0441)	31438-80X68
1.16 (0.0457)	31438-80X69
1.20 (0.0472)	31438-80X70

*: Always check with the Parts Department for the latest parts information.

Bearing Retainer SEAL RING CLEARANCE

ECS00689

Bearing retainer seal ring clearance mm (in)	Standard	0.10 - 0.30 (0.0039 - 0.0118)
	Allowable limit	0.30 (0.0118)

Total End Play

ECS0068A

Total end play mm (in)	0.25 - 0.55 (0.0098 - 0.0217)
------------------------	-------------------------------

BEARING RACE FOR ADJUSTING TOTAL END PLAY

Thickness mm (in)	Part number*
0.8 (0.031)	31435-80X00
1.0 (0.039)	31435-80X01
1.2 (0.047)	31435-80X02
1.4 (0.055)	31435-80X03
1.6 (0.063)	31435-80X04
1.8 (0.071)	31435-80X05
2.0 (0.079)	31435-80X06
0.9 (0.035)	31435-80X09
1.1 (0.043)	31435-80X10
1.3 (0.051)	31435-80X11
1.5 (0.059)	31435-80X12
1.7 (0.067)	31435-80X13
1.9 (0.075)	31435-80X14

*: Always check with the Parts Department for the latest parts information.

Reverse Clutch End Play

ECS0068B

Reverse clutch end play mm (in)	0.55 - 0.90 (0.0217 - 0.0354)
---------------------------------	-------------------------------

THRUST WASHERS FOR ADJUSTING REVERSE CLUTCH DRUM END PLAY

Thickness mm (in)	Part number*
0.80 (0.0315)	31508-80X13
0.95 (0.0374)	31508-80X14
1.10 (0.0433)	31508-80X15
1.25 (0.0492)	31508-80X16
1.40 (0.0551)	31508-80X17
1.55 (0.0610)	31508-80X18
1.70 (0.0669)	31508-80X19
1.85 (0.0728)	31508-80X20

*: Always check with the Parts Department for the latest parts information.

Removal and Installation

ECS0068C

Unit: mm (in)

Distance between end of converter housing and torque converter	14 (0.55)
--	-----------

PRECAUTIONS

PRECAUTIONS

PF0:00001

Precautions for Supplemental Restraint System (SRS) “AIR BAG” and “SEAT BELT PRE-TENSIONER”

EIS00140

The Supplemental Restraint System such as “AIR BAG” and “SEAT BELT PRE-TENSIONER”, used along with a front seat belt, helps to reduce the risk or severity of injury to the driver and front passenger for certain types of collision. Information necessary to service the system safely is included in the SRS and SB section of this Service Manual.

WARNING:

- To avoid rendering the SRS inoperative, which could increase the risk of personal injury or death in the event of a collision which would result in air bag inflation, all maintenance must be performed by an authorized NISSAN/INFINITI dealer.
- Improper maintenance, including incorrect removal and installation of the SRS, can lead to personal injury caused by unintentional activation of the system. For removal of Spiral Cable and Air Bag Module, see the SRS section.
- Do not use electrical test equipment on any circuit related to the SRS unless instructed to in this Service Manual. SRS wiring harnesses can be identified by yellow and/or orange harness connectors.

A
B
C
D
E
F
G
H
J
K
L
M

BL

REMOTE KEYLESS ENTRY SYSTEM

EIS00157

Wiring Diagram — KEYLES —
FIG. 1

BL-KEYLES-01

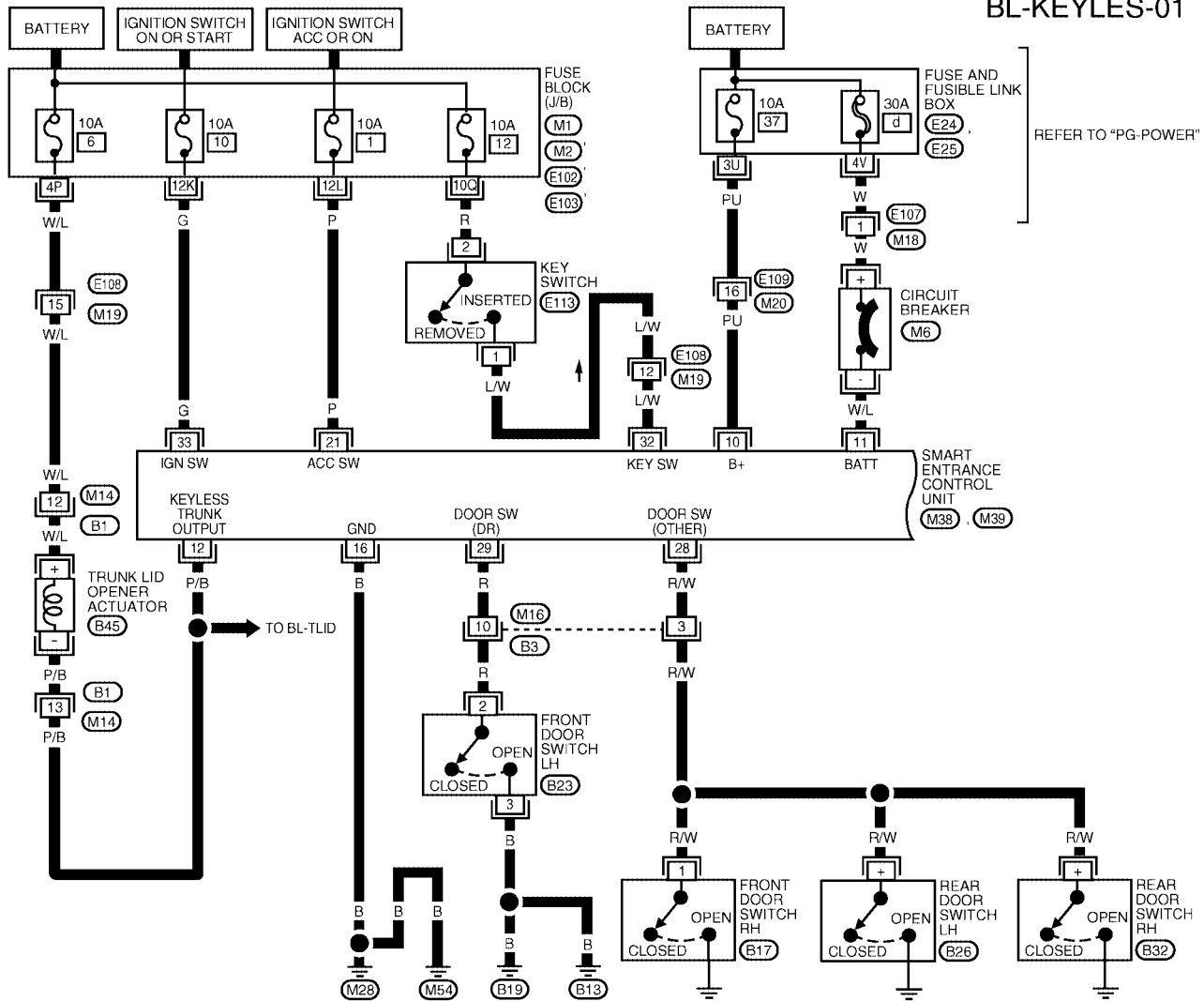

REFER TO "PG-POWER"

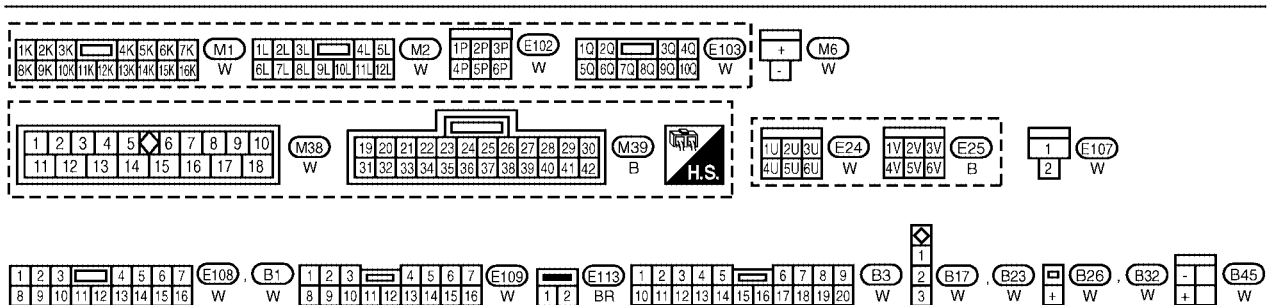

WIWA0313E

VEHICLE SECURITY (THEFT WARNING) SYSTEM

FIG. 2

BL-VEHSEC-02

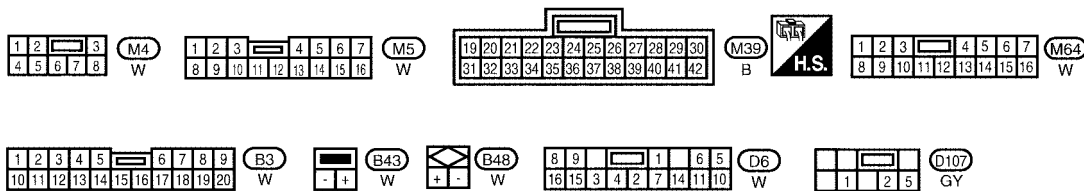
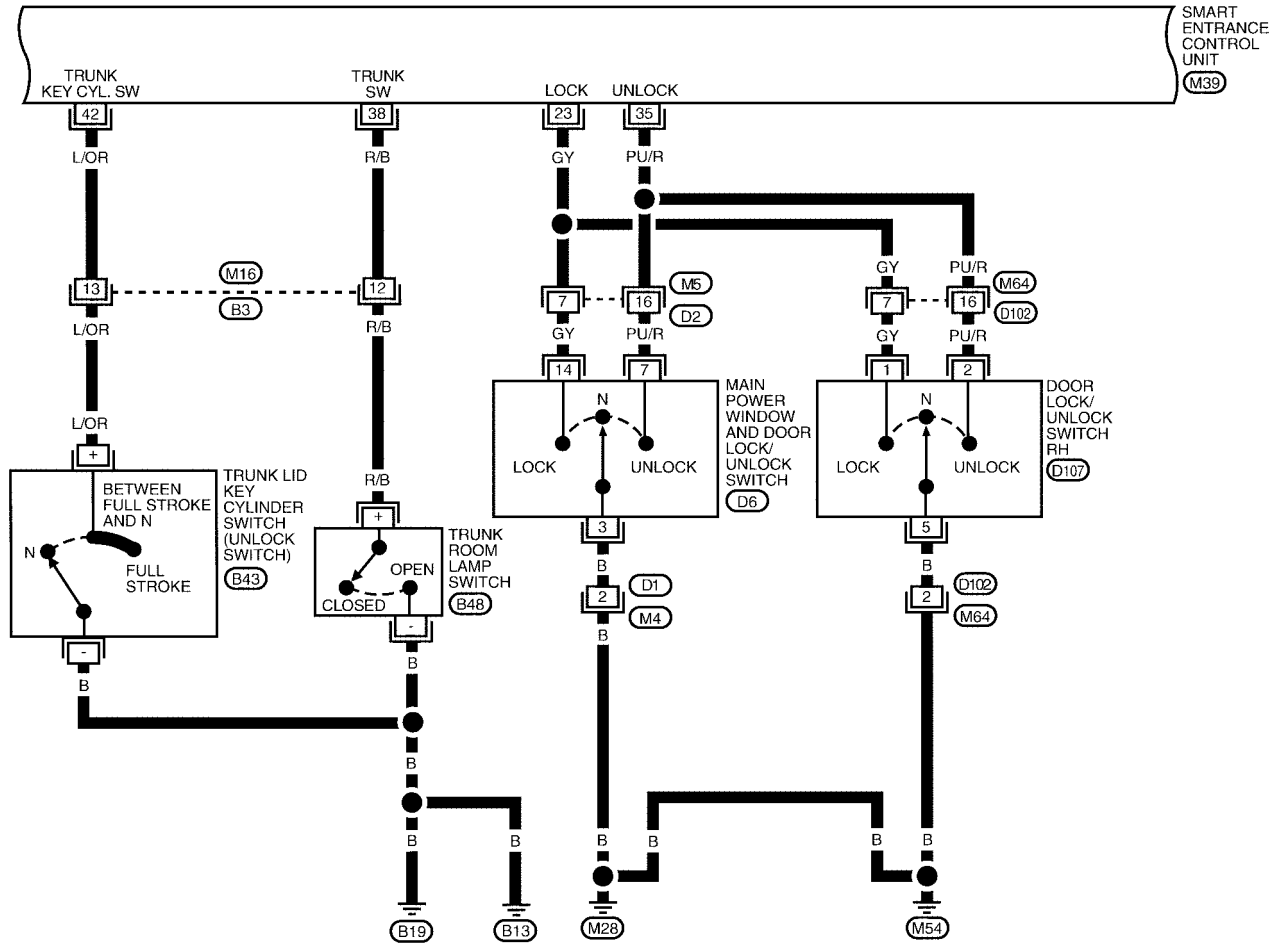

WIWA1211E

SMART ENTRANCE CONTROL UNIT TERMINALS AND REFERENCE VALUE MEASURED BETWEEN EACH TERMINAL AND GROUND

TERMINAL	WIRE COLOR	ITEM	CONDITION	DATA (DC)
23	GY	DOOR LOCK & UNLOCK SWITCHES	NEUTRAL	5V
			LOCKS	0V
35	PU/R	DOOR LOCK & UNLOCK SWITCHES	NEUTRAL	5V
			UNLOCKS	0V
38	R/B	TRUNK ROOM LAMP SWITCH	ON (OPEN)	0V
			OFF (CLOSED)	12V
42	L/OR	TRUNK LID KEY CYLINDER SWITCH	OFF (NEUTRAL)	5V
			ON (UNLOCK)	0V

LIIA0847E

NVIS (NISSAN VEHICLE IMMOBILIZER SYSTEM — NATS)

7. CHECK COMMUNICATION LINE GROUND SHORT CIRCUIT

1. Turn ignition switch OFF.
2. Check continuity between ECM harness connector F59 terminal 88 (BR/Y) or NVIS (NATS) IMMU connector E111 terminal 1 (BR/Y) and ground.

Continuity should not exist.

OK or NG

- OK >> GO TO 8.
- NG >> ● Communication line is short-circuited with ground line.
- Repair or replace harness.
 - **Ref. part No. C4**

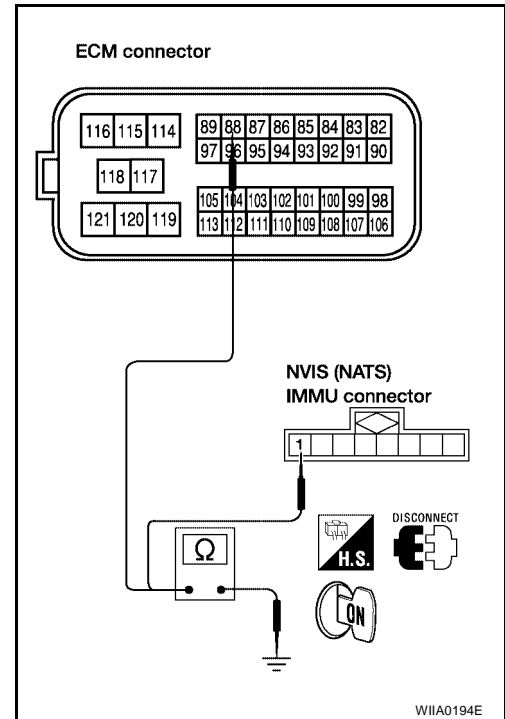

8. SIGNAL FROM ECM TO NVIS (NATS) IMMU CHECK

1. Check the signal between ECM terminal 88 and ground with CONSULT-II or oscilloscope when ignition switch is turned ON.
2. Make sure signals which are shown in the figure below can be detected during 750 msec. just after ignition switch is turned ON.

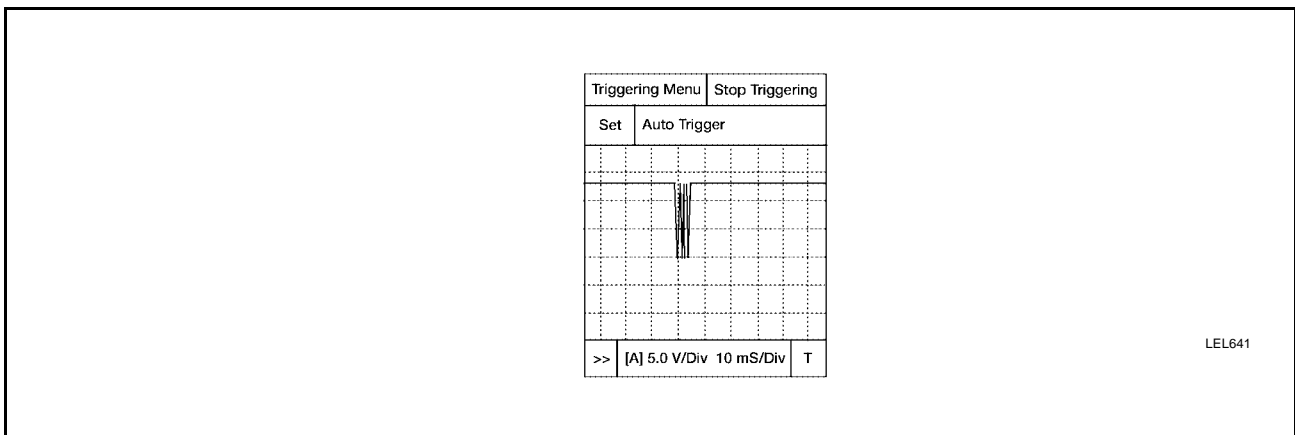

OK or NG

- OK >> ● NVIS (NATS) IMMU is malfunctioning.
- Replace NVIS (NATS) IMMU. **Ref. part No. A**
 - Perform initialization with CONSULT-II.
 - For the operation of initialization, refer to “CONSULT-II OPERATION MANUAL IVIS/NVIS”.
- NG >> ● ECM is malfunctioning.
- Replace ECM. **Ref. part No. B**
 - Perform initialization with CONSULT-II.
 - For the operation of initialization, refer to “CONSULT-II OPERATION MANUAL IVIS/NVIS”.

FRONT DISC BRAKE (OPB27VA TYPE)

FRONT DISC BRAKE (OPB27VA TYPE)

PFP:41000

On-board Inspection PAD WEAR INSPECTION

EFS0031J

- Inspect the thickness of the pad through the caliper inspection hole. Use a ruler or caliper for inspection if necessary.

Standard

Standard thickness : 9.3 mm (0.366 in)

Repair limit thickness : 2.0 mm (0.079 in)

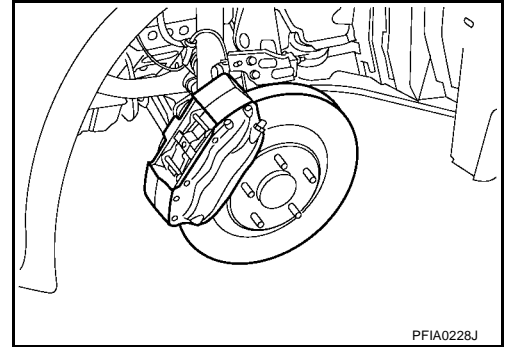

PFIA0228J

Component

EFS0031K

NOTE:

Refer to [BR-25. "HOW TO APPLY GREASE TO THE BRAKE PAD"](#) for how to apply grease to brake pads.

SEC.440

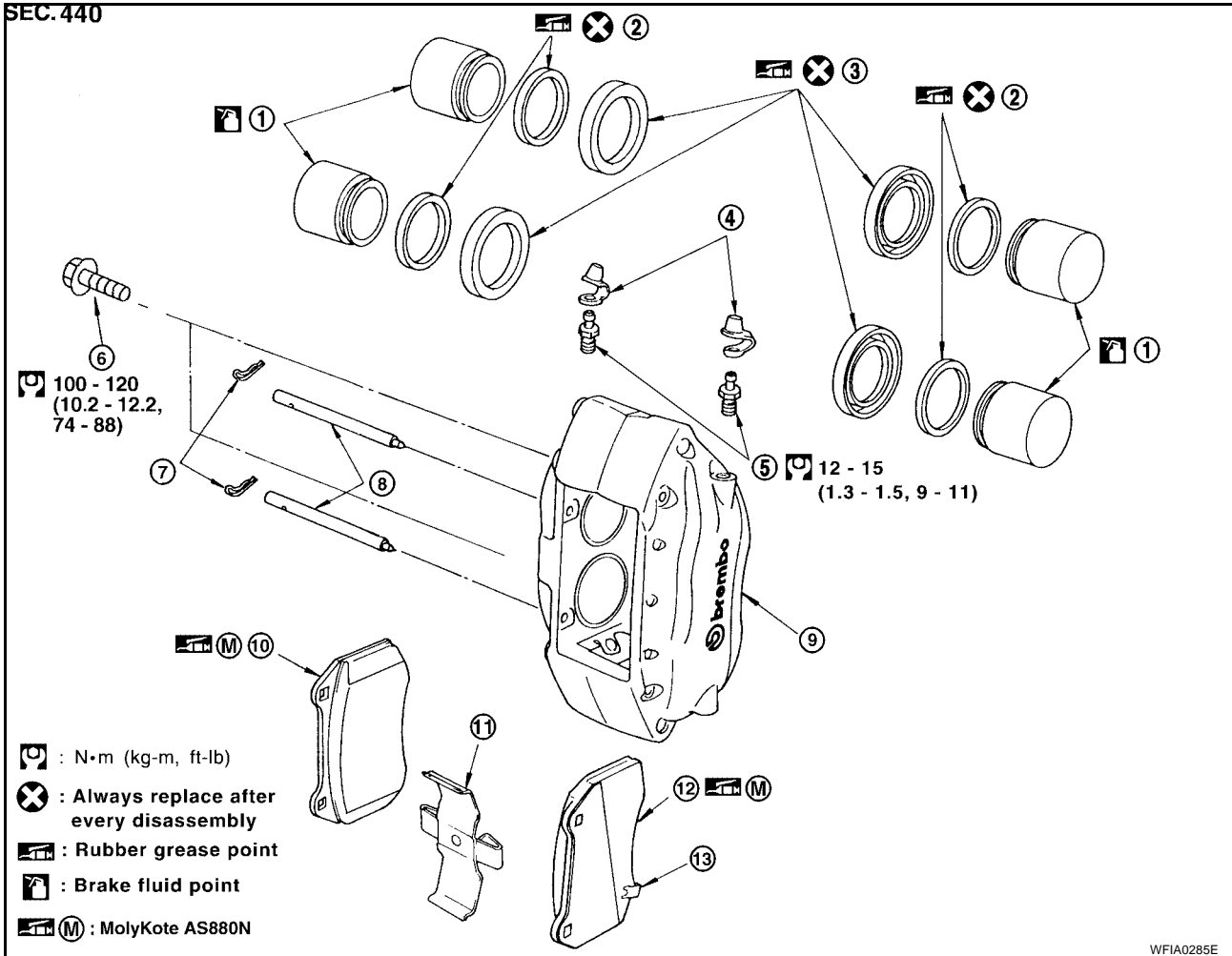

: N·m (kg-m, ft-lb)

: Always replace after every disassembly

: Rubber grease point

: Brake fluid point

(M) : MolyKote AS880N

WFIA0285E

- | | | |
|---------------------|---------------------|----------------|
| 1. Piston | 2. Piston seal | 3. Piston boot |
| 4. Cap | 5. Air bleeder | 6. Bolt |
| 7. Clips | 8. Pad pins | 9. Caliper |
| 10. Inner pad | 11. Cross spring | 12. Outer pad |
| 13. Pad wear sensor | 14. Pad wear sensor | |

ON BOARD DIAGNOSTIC SYSTEM DESCRIPTION

PFP:00000

Self-diagnosis FUNCTION

EFS0024E

- When a problem occurs in the ABS, the warning lamp on the instrument panel comes on. To start the self-diagnostic results mode, ground the self-diagnostic (check) terminal located on Data Link Connector. The location of the malfunction is indicated by the warning lamp flashing.

SELF-DIAGNOSIS PROCEDURE

- Drive vehicle over 30 km/h (19 MPH) for at least one minute.
- Turn ignition switch OFF.
- Ground terminal 9 of Data Link Connector with a suitable harness.
- Turn ignition switch ON while grounding terminal 9.
Do not depress brake pedal.

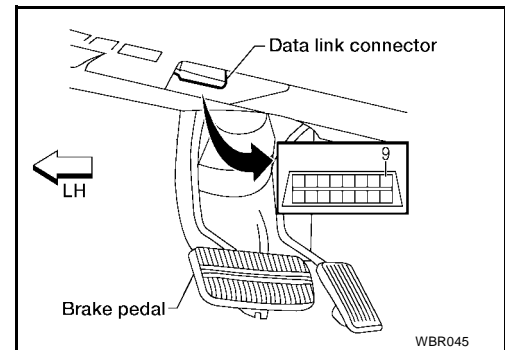

- After 3.0 seconds, the warning lamp starts flashing to indicate the malfunction code No. (See NOTE.)
- Verify the location of the malfunction with the malfunction code chart. Refer to [BRC-26, "Malfunction Code/Symptom Chart"](#). Then make the necessary repairs following the diagnostic procedures.
- After the malfunctions are repaired, erase the malfunction codes stored in the control unit. Refer to [BRC-15, "HOW TO ERASE SELF-DIAGNOSTIC RESULTS \(MALFUNCTION CODES\)"](#).
- Repeat the self-diagnostic results mode to verify that the malfunction codes have been erased.

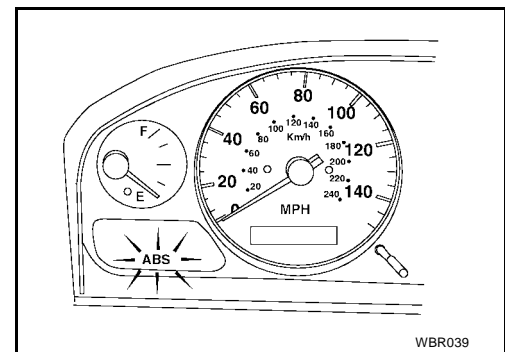

- Disconnect the check terminal from ground. The self-diagnostic results mode is now complete.
- Check warning lamp for deactivation after driving vehicle over 30 km/h (19 MPH) for at least one minute.
- After making certain that warning lamp does not come on, test the ABS in a safe area to verify that it functions properly.

NOTE:

The indication terminates after 5 minutes. However, when the ignition switch is turned from OFF to ON, the indication starts flashing again.

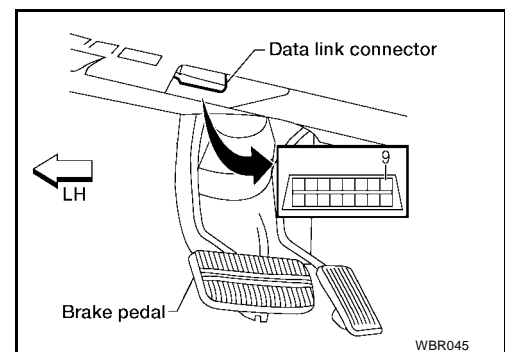

A
B
CL
D
E
F
G
H
I
J
K
L
M

SECTION **CL** CLUTCH

CONTENTS

QG18DE	
PRECAUTIONS	3
Precautions	3
PREPARATION	4
Special Service Tools	4
Commercial Service Tools	4
NOISE, VIBRATION, AND HARSHNESS (NVH)	
TROUBLESHOOTING	5
NVH Troubleshooting Chart	5
CLUTCH SYSTEM	6
Components	6
Inspection and Adjustment	7
CLUTCH PEDAL INSPECTION AND ADJUST- MENT	7
BLEEDING PROCEDURE	7
CLUTCH MASTER CYLINDER	9
Components	9
Removal	9
Disassembly	9
Inspection	10
Assembly	10
Installation	10
OPERATING CYLINDER	11
Components	11
Removal	11
Disassembly	11
Inspection	11
Assembly	12
Installation	12
PIPING	13
Removal	13
Installation	13
CLUTCH RELEASE MECHANISM	14
Components	14
Removal	14
Inspection	14
Installation	14
CLUTCH DISC, CLUTCH COVER AND FLYWHEEL	17
Components	17
Removal	17
Inspection and Adjustment	17
CLUTCH DISC	17
CLUTCH COVER AND FLYWHEEL	18
FLYWHEEL INSPECTION	18
Installation	18
SERVICE DATA AND SPECIFICATIONS (SDS)	19
Clutch Control System	19
Clutch Master Cylinder	19
Clutch Operating Cylinder	19
Clutch Disc	19
Clutch Cover	19
Clutch Pedal	19
	QR25DE
PRECAUTIONS	20
Precautions	20
PREPARATION	21
Special Service Tools	21
Commercial Service Tools	21
NOISE, VIBRATION, AND HARSHNESS (NVH)	
TROUBLESHOOTING	22
NVH Troubleshooting Chart	22
CLUTCH SYSTEM	23
Components	23
Inspection and Adjustment	24
CLUTCH PEDAL INSPECTION AND ADJUST- MENT	24
BLEEDING PROCEDURE	24
CLUTCH MASTER CYLINDER	26
Components	26
Removal	26
Disassembly	26
Inspection	26
Assembly	27
Installation	27
OPERATING CYLINDER	28
Components	28
Removal	28
Disassembly	28

RADIATOR

[QR25DE]

2. Clean contact portion of tank.

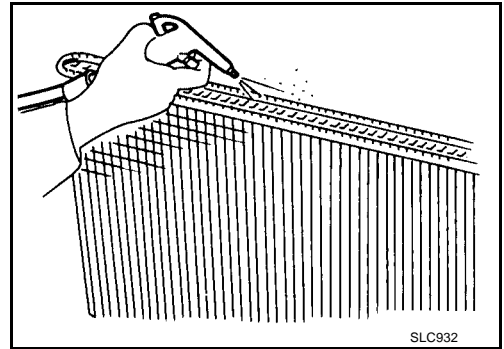

3. Install sealing rubber.

NOTE:

Push it in with fingers.

CAUTION:

Be careful not to twist sealing rubber.

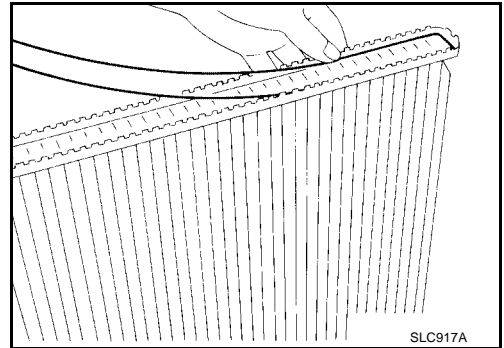

4. Crimp tank in specified sequence using Tool.

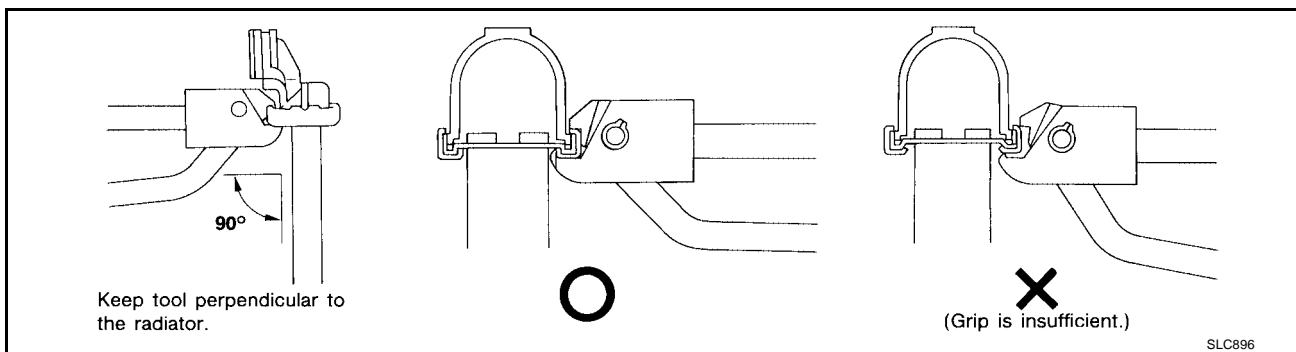
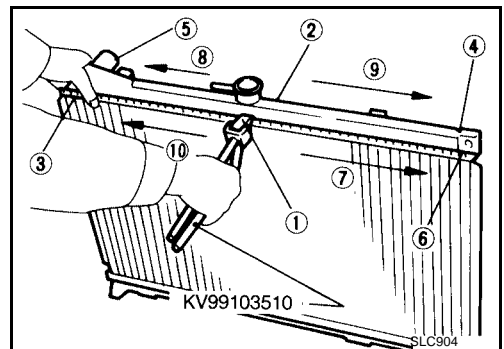

- Use pliers in the locations where Tool cannot be used.

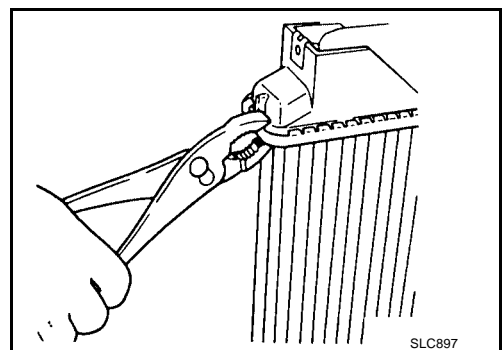

A
CO
C
D
E
F
G
H
I
J
K
L
M

WARNING LAMPS

WITH TACHOMETER (QG18DE MODELS)

DI-WARN-04

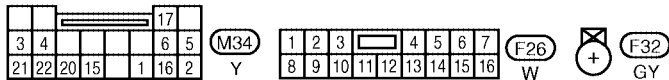
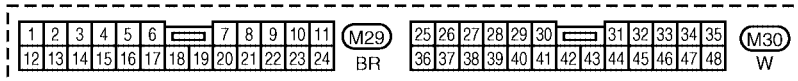
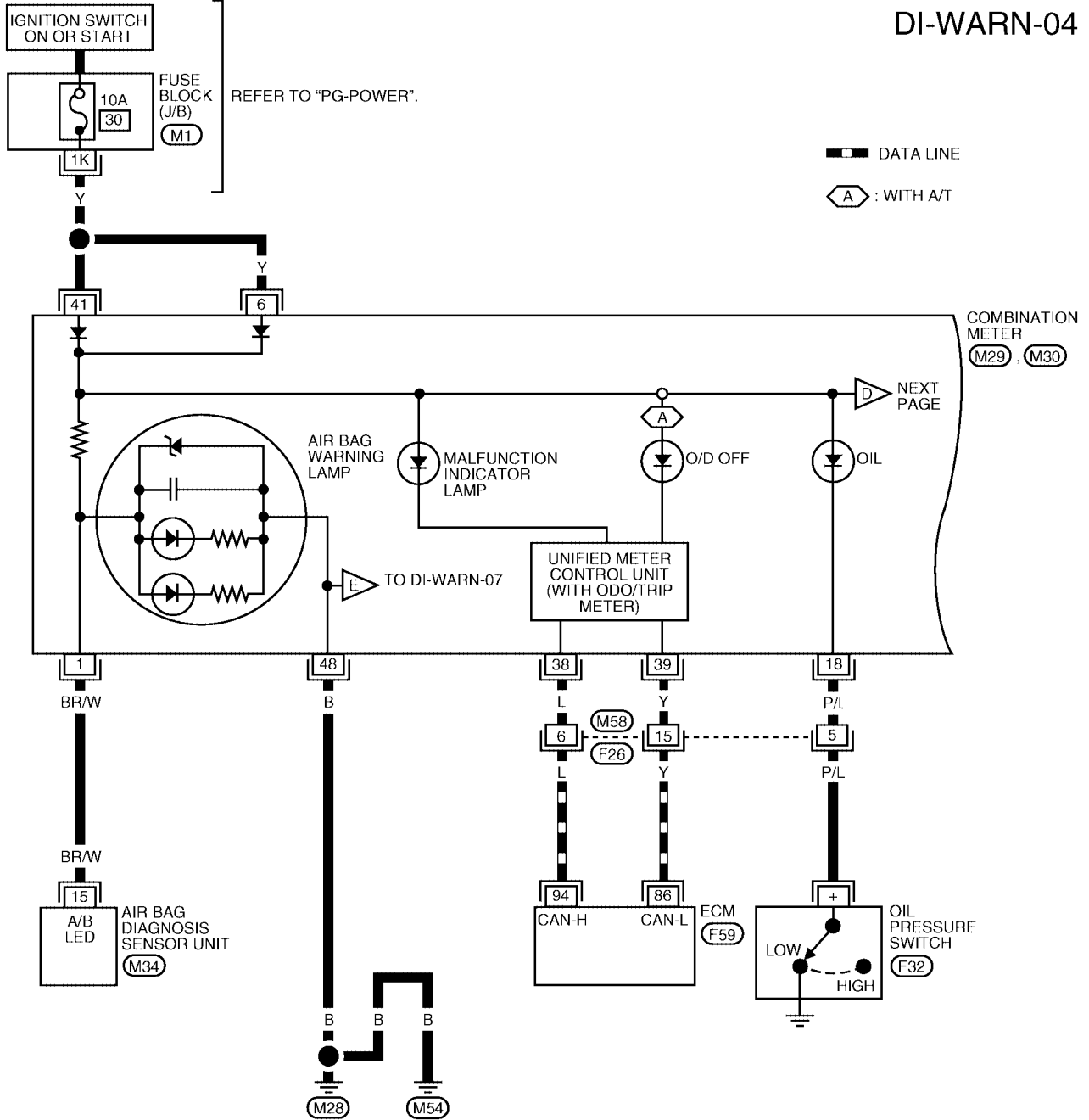

REFER TO THE FOLLOWING.

F59 - ELECTRICAL UNITS

WKWA1618E

DTC P0171 FUEL INJECTION SYSTEM FUNCTION	242	DTC P0340 CMP SENSOR (PHASE)	291	
On Board Diagnosis Logic	242	Component Description	291	A
DTC Confirmation Procedure	242	On Board Diagnosis Logic	291	
Wiring Diagram	244	DTC Confirmation Procedure	291	
Diagnostic Procedure	245	Wiring Diagram	293	EC
DTC P0172 FUEL INJECTION SYSTEM FUNCTION	249	Diagnostic Procedure	294	
On Board Diagnosis Logic	249	Component Inspection	297	
DTC Confirmation Procedure	249	Removal and Installation	297	
Wiring Diagram	251	DTC P0420 THREE WAY CATALYST FUNCTION	298	C
Diagnostic Procedure	252	On Board Diagnosis Logic	298	
DTC P0181 FTT SENSOR	256	DTC Confirmation Procedure	298	
Component Description	256	Overall Function Check	299	D
On Board Diagnosis Logic	256	Diagnostic Procedure	300	
DTC Confirmation Procedure	256	DTC P0441 EVAP CONTROL SYSTEM	303	E
Wiring Diagram	258	System Description	303	
Diagnostic Procedure	259	On Board Diagnosis Logic	303	
Component Inspection	260	DTC Confirmation Procedure	304	
Removal and Installation	260	Overall Function Check	304	
DTC P0182, P0183 FTT SENSOR	261	Diagnostic Procedure	305	F
Component Description	261	DTC P0442 EVAP CONTROL SYSTEM	309	
On Board Diagnosis Logic	261	On Board Diagnosis Logic	309	G
DTC Confirmation Procedure	261	DTC Confirmation Procedure	310	
Wiring Diagram	262	Diagnostic Procedure	311	
Diagnostic Procedure	263	DTC P0444, P0445 EVAP CANISTER PURGE VOL-		
Component Inspection	264	UME CONTROL SOLENOID VALVE	318	H
Removal and Installation	264	Description	318	
DTC P0222, P0223 TP SENSOR	265	CONSULT-II Reference Value in Data Monitor Mode		
Component Description	265	On Board Diagnosis Logic	319	I
CONSULT-II Reference Value in Data Monitor Mode	265	DTC Confirmation Procedure	319	
On Board Diagnosis Logic	265	Wiring Diagram	320	J
DTC Confirmation Procedure	266	Diagnostic Procedure	322	
Wiring Diagram	267	Component Inspection	323	
Diagnostic Procedure	268	Removal and Installation	324	
Component Inspection	271	DTC P0447 EVAP CANISTER VENT CONTROL		K
Removal and Installation	271	VALVE	325	
DTC P0300 - P0304 NO. 4 - 1 CYLINDER MISFIRE, MULTIPLE CYLINDER MISFIRE	272	Component Description	325	L
On Board Diagnosis Logic	272	CONSULT-II Reference Value in Data Monitor Mode		
DTC Confirmation Procedure	273	On Board Diagnosis Logic	325	
Diagnostic Procedure	273	DTC Confirmation Procedure	325	
DTC P0327, P0328 KS	279	Wiring Diagram	327	M
Component Description	279	Diagnostic Procedure	328	
On Board Diagnosis Logic	279	Component Inspection	330	
DTC Confirmation Procedure	279	DTC P0451 EVAP CONTROL SYSTEM PRESSURE		
Wiring Diagram	280	SENSOR	332	
Diagnostic Procedure	281	Component Description	332	
Component Inspection	282	CONSULT-II Reference Value in Data Monitor Mode		
Removal and Installation	283	On Board Diagnosis Logic	332	
DTC P0335 CKP SENSOR (POS)	284	DTC Confirmation Procedure	332	
Component Description	284	Diagnostic Procedure	333	
CONSULT-II Reference Value in Data Monitor Mode	284	Component Inspection	334	
On Board Diagnosis Logic	284	DTC P0452 EVAP CONTROL SYSTEM PRESSURE		
DTC Confirmation Procedure	284	SENSOR	335	
Wiring Diagram	286	Component Description	335	
Diagnostic Procedure	287	CONSULT-II Reference Value in Data Monitor Mode		
Component Inspection	289	On Board Diagnosis Logic	335	
Removal and Installation	290			

EVAPORATIVE EMISSION SYSTEM

[QG18DE]

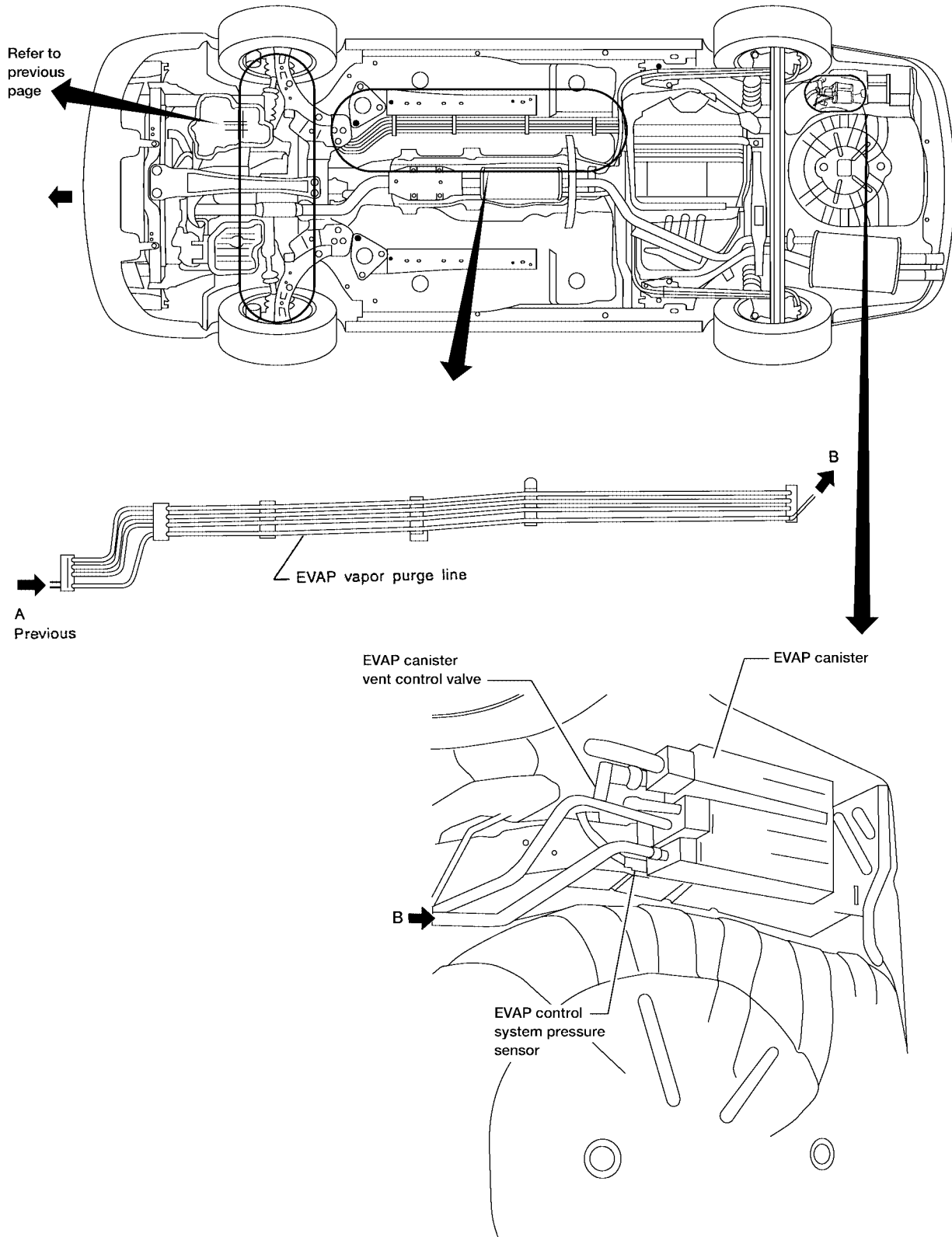

BBIA0294E

EXPLANATION FOR DRIVING PATTERNS EXCEPT FOR "MISFIRE <EXHAUST QUALITY DETERIORATION>", "FUEL INJECTION SYSTEM"

<Driving Pattern A>

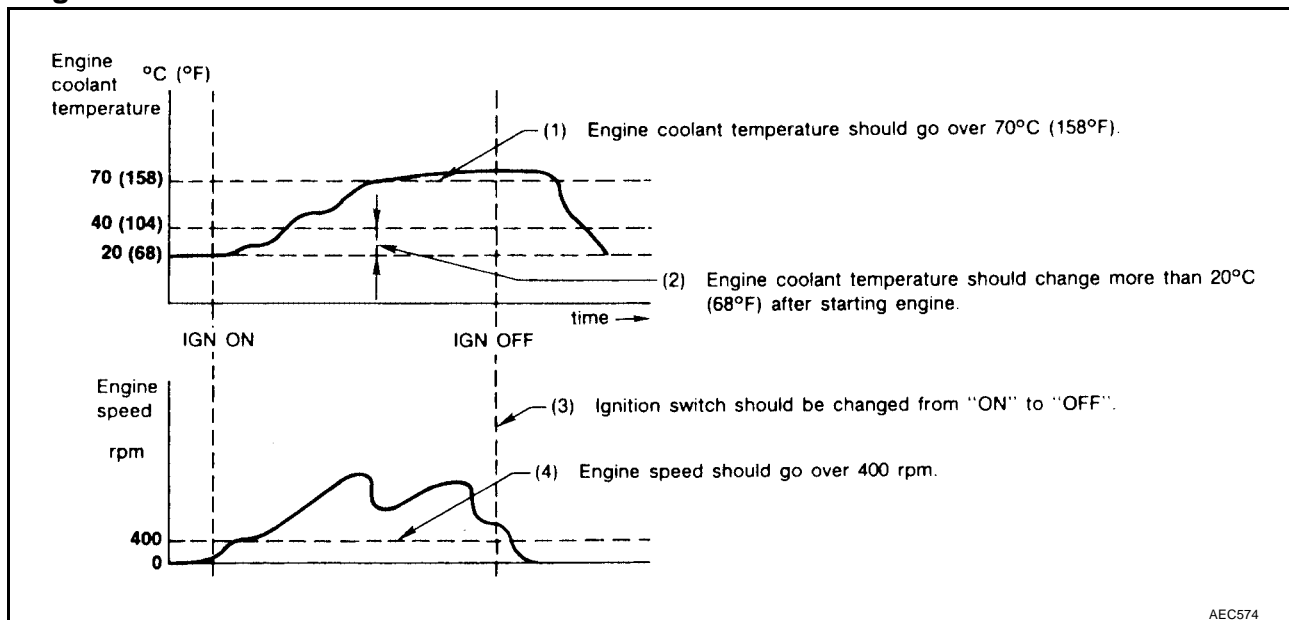

- The A counter will be cleared when the malfunction is detected regardless of (1) - (4).
- The A counter will be counted up when (1) - (4) are satisfied without the same malfunction.
- The DTC will not be displayed after the A counter reaches 40.

<Driving Pattern B>

Driving pattern B means the vehicle operation as follows:

All components and systems should be monitored at least once by the OBD system.

- The B counter will be cleared when the malfunction is detected once regardless of the driving pattern.
- The B counter will be counted up when driving pattern B is satisfied without any malfunctions.
- The MIL will go off when the B counter reaches 3 (*2 in "OBD SYSTEM OPERATION CHART").

TROUBLE DIAGNOSIS

[QG18DE]

SYSTEM — ENGINE MECHANICAL & OTHER

		SYMPTOM											Reference page			
		HARD/NO START/RESTART (EXCP. HA)	ENGINE STALL	HESITATION/SURGING/FLAT SPOT	SPARK KNOCK/DETONATION	LACK OF POWER/POOR ACCELERATION	HIGH IDLE/LOW IDLE	ROUGH IDLE/HUNTING	IDLING VIBRATION	SLOW/NO RETURN TO IDLE	OVERHEATS/WATER TEMPERATURE HIGH	EXCESSIVE FUEL CONSUMPTION		EXCESSIVE OIL CONSUMPTION	BATTERY DEAD (UNDER CHARGE)	
Warranty symptom code		AA	AB	AC	AD	AE	AF	AG	AH	AJ	AK	AL	AM	HA		
Fuel	Fuel tank	5	5												FL-7	
	Fuel piping			5	5	5		5	5			5			EM-21	
	Vapor lock															—
	Valve deposit															—
	Poor fuel (Heavy weight gasoline, Low octane)	5			5	5	5		5	5			5			—
Air	Air duct														—	
	Air cleaner														—	
	Air leakage from air duct (Mass air flow sensor —electric throttle control actuator)		5	5		5		5	5			5			—	
	Electric throttle control actuator	5			5		5			5					EM-15	
	Air leakage from intake manifold/Collector/Gasket														EM-15	
Cranking	Battery	1	1	1		1		1	1					1	SC-4	
	Generator circuit															
	Starter circuit	3										1			SC-9	
	Signal plate/Flywheel/Drive plate	6													EM-92	
	PNP switch	4													MT-12 or AT-115	
Engine	Cylinder head	5	5	5	5	5		5	5			5	3		EM-55	
	Cylinder head gasket														4	
	Cylinder block															
	Piston												4			
	Piston ring	6	6	6	6	6		6	6			6			EM-69	
	Connecting rod															
	Bearing															
	Crankshaft															

TROUBLE DIAGNOSIS

[QG18DE]

Monitored item [Unit]	ECM INPUT SIGNALS	MAIN SIGNALS	Description	Remarks
B/FUEL SCHDL [msec]			<ul style="list-style-type: none"> ● "Base fuel schedule" indicates the fuel injection pulse width programmed into ECM, prior to any learned on board correction. 	<ul style="list-style-type: none"> ● When engine is running specification range is indicated.
A/F ALPHA-B1 [%]		×	<ul style="list-style-type: none"> ● The mean value of the air-fuel ratio feedback correction factor per cycle is indicated. 	<ul style="list-style-type: none"> ● When engine is running specification range is indicated. ● This data also includes the data for the air-fuel ratio learning control.

NOTE:

Any monitored item that does not match the vehicle being diagnosed is deleted from the display automatically.

ACTIVE TEST MODE

Test Item

TEST ITEM	CONDITION	JUDGEMENT	CHECK ITEM (REMEDY)
FUEL INJECTION	<ul style="list-style-type: none"> ● Engine: Return to the original trouble condition ● Change the amount of fuel injection using CONSULT-II. 	If trouble symptom disappears, see CHECK ITEM.	<ul style="list-style-type: none"> ● Harness and connectors ● Fuel injector ● A/F sensor 1
IGNITION TIMING	<ul style="list-style-type: none"> ● Engine: Return to the original trouble condition ● Timing light: Set ● Retard the ignition timing using CONSULT-II. 	If trouble symptom disappears, see CHECK ITEM.	<ul style="list-style-type: none"> ● Perform Idle Air Volume Learning.
POWER BALANCE	<ul style="list-style-type: none"> ● Engine: After warming up, idle the engine. ● A/C switch OFF ● Shift lever: P or N ● Cut off each injector signal one at a time using CONSULT-II. 	Engine runs rough or dies.	<ul style="list-style-type: none"> ● Harness and connectors ● Compression ● Fuel injector ● Power transistor ● Spark plug ● Ignition coil
COOLING FAN	<ul style="list-style-type: none"> ● Ignition switch: ON ● Turn the cooling fan "HI", "LOW" and "OFF" with CONSULT-II. 	Cooling fan moves and stops.	<ul style="list-style-type: none"> ● Harness and connectors ● Cooling fan relay ● Cooling fan motor
ENG COOLANT TEMP	<ul style="list-style-type: none"> ● Engine: Return to the original trouble condition ● Change the engine coolant temperature using CONSULT-II. 	If trouble symptom disappears, see CHECK ITEM.	<ul style="list-style-type: none"> ● Harness and connectors ● Engine coolant temperature sensor ● Fuel injector
FUEL PUMP RELAY	<ul style="list-style-type: none"> ● Ignition switch: ON (Engine stopped) ● Turn the fuel pump relay "ON" and "OFF" using CONSULT-II and listen to operating sound. 	Fuel pump relay makes the operating sound.	<ul style="list-style-type: none"> ● Harness and connectors ● Fuel pump relay
VALVE TIMING SOL	<ul style="list-style-type: none"> ● Ignition switch: ON (Engine stopped) ● Turn solenoid valve "ON" and "OFF" with the CONSULT-II and listen to operating sound. 	Solenoid valve makes an operating sound.	<ul style="list-style-type: none"> ● Harness and connectors ● Solenoid valve
PURG VOL CONT/V	<ul style="list-style-type: none"> ● Engine: After warming up, run engine at 1,500 rpm. ● Change the EVAP canister purge volume control solenoid valve opening percent using CONSULT-II. 	Engine speed changes according to the opening percent.	<ul style="list-style-type: none"> ● Harness and connectors ● Solenoid valve

7. If 1st trip DTC is detected, go to [EC-178, "Diagnostic Procedure"](#).

 **WITH GST**

Follow the procedure "WITH CONSULT-II" above.

Diagnostic Procedure

UBS00B3Y

1. CHECK OIL PRESSURE WARNING LAMP

1. Start engine.
2. Check oil pressure warning lamp and confirm it is not illuminated.

OK or NG

- OK >> GO TO 2.
NG >> Go to [DI-27](#).

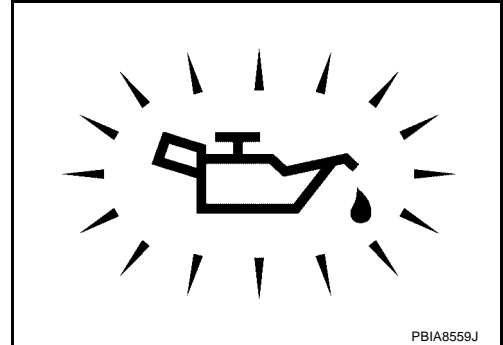

2. CHECK INTAKE VALVE TIMING CONTROL SOLENOID VALVE

Refer to [EC-176](#).

OK or NG

- OK >> GO TO 3.
NG >> Replace intake valve timing control solenoid valve.

3. CHECK CRANKSHAFT POSITION SENSOR (POS)

Refer to [EC-297, "Component Inspection"](#).

OK or NG

- OK >> GO TO 4.
NG >> Replace crankshaft position sensor (POS).

4. CHECK CAMSHAFT POSITION SENSOR (PHASE)

Refer to [EC-297, "Component Inspection"](#).

OK or NG

- OK >> GO TO 5.
NG >> Replace camshaft position sensor (PHASE).

5. CHECK CAMSHAFT (INTAKE)

Check the following.

- Accumulation of debris to the signal plate of camshaft rear end
- Chipping signal plate of camshaft rear end

OK or NG

- OK >> GO TO 8.
NG >> Remove debris and clean the signal plate of camshaft rear end or replace camshaft.

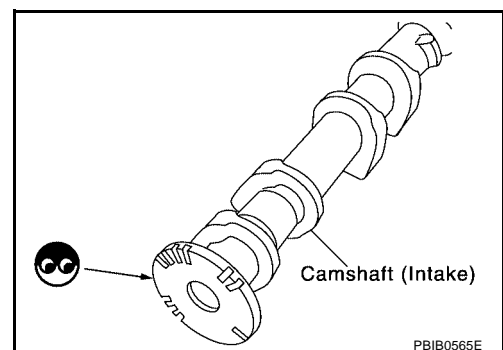

DTC P0122, P0123 TP SENSOR

PF16119

Component Description

UBS00B4Z

Electric throttle control actuator consists of throttle control motor, throttle position sensor, etc. The throttle position sensor responds to the throttle valve movement.

The throttle position sensor has the two sensors. These sensors are a kind of potentiometers which transform the throttle valve position into output voltage, and emit the voltage signal to the ECM. In addition, these sensors detect the opening and closing speed of the throttle valve and feed the voltage signals to the ECM. The ECM judges the current opening angle of the throttle valve from these signals and the ECM controls the throttle control motor to make the throttle valve opening angle properly in response to driving condition.

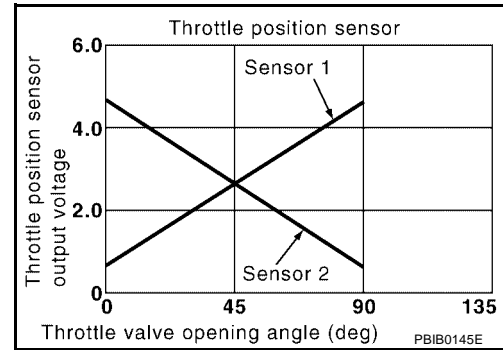

CONSULT-II Reference Value in Data Monitor Mode

UBS00B50

Specification data are reference values.

MONITOR ITEM	CONDITION		SPECIFICATION
THRTL SEN 1 THRTL SEN 2*	● Ignition switch: ON (Engine stopped)	Accelerator pedal: Fully released	More than 0.36V
	● Shift lever: D (A/T), 1st (M/T)	Accelerator pedal: Fully depressed	Less than 4.75V

*: Throttle position sensor 2 signal is converted by ECM internally. Thus, it differs from ECM terminal voltage signal.

On Board Diagnosis Logic

UBS00B51

These self-diagnoses have the one trip detection logic.

DTC No.	Trouble diagnosis name	DTC detecting condition	Possible cause
P0122 0122	Throttle position sensor 2 circuit low input	An excessively low voltage from the TP sensor 2 is sent to ECM.	<ul style="list-style-type: none"> ● Harness or connectors (The TP sensor 2 circuit is open or shorted.) (APP sensor 2 circuit is shorted.) ● Electric throttle control actuator (TP sensor 2) Accelerator pedal position sensor.
P0123 0123	Throttle position sensor 2 circuit high input	An excessively high voltage from the TP sensor 2 is sent to ECM.	

FAIL-SAFE MODE

When the malfunction is detected, the ECM enters fail-safe mode and the MIL lights up.

Engine operation condition in fail-safe mode

The ECM controls the electric throttle control actuator in regulating the throttle opening in order for the idle position to be within +10 degrees.

The ECM regulates the opening speed of the throttle valve to be slower than the normal condition.

So, the acceleration will be poor.

9. CHECK INJECTOR

1. Disconnect all ignition coil harness connectors.
2. Place pans or saucers under each injector.
3. Crank engine for about 3 seconds. Make sure that fuel sprays out from injectors.

Fuel should be sprayed evenly for each cylinder.

OK or NG

OK >> GO TO 10.

NG >> Replace injectors from which fuel does not spray out.
Always replace O-ring with new one.

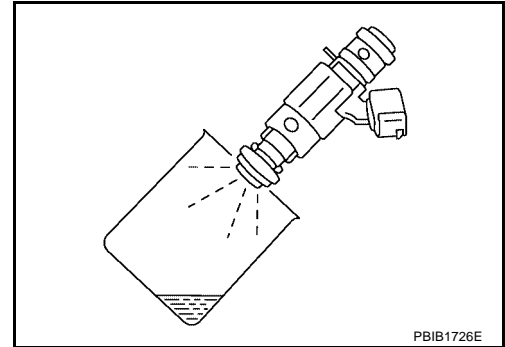

10. CHECK INTERMITTENT INCIDENT

Perform [EC-164, "TROUBLE DIAGNOSIS FOR INTERMITTENT INCIDENT"](#) .

>> INSPECTION END

Removal and Installation
KNOCK SENSOR

Refer to [EM-69, "CYLINDER BLOCK"](#) .

A

EC

C

D

E

F

G

H

I

J

K

L

M

DTC P0444, P0445 EVAP CANISTER PURGE VOLUME CONTROL SOLENOID VALVE

[QG18DE]

DTC P0444, P0445 EVAP CANISTER PURGE VOLUME CONTROL SOLENOID VALVE

PFP:14920

Description SYSTEM DESCRIPTION

UBS00B7Z

Sensor	Input Signal to ECM	ECM function	Actuator
Crankshaft position sensor (POS) Camshaft position sensor (PHASE)	Engine speed*2	EVAP canister purge flow control	EVAP canister purge volume control solenoid valve
Mass air flow sensor	Amount of intake air		
Engine coolant temperature sensor	Engine coolant temperature		
Battery	Battery voltage*2		
Throttle position sensor	Throttle position		
Accelerator pedal position sensor	Accelerator pedal position		
Air fuel ratio (A/F) sensor 1	Density of oxygen in exhaust gas (Mixture ratio feedback signal)		
Vehicle speed signal*1	Vehicle speed		

*1: This signal is sent to the ECM through CAN communication line.

*2: The ECM determines the start signal status by the signal of engine speed and battery voltage.

This system controls flow rate of fuel vapor from the EVAP canister. The opening of the vapor by-pass passage in the EVAP canister purge volume control solenoid valve changes to control the flow rate. The EVAP canister purge volume control solenoid valve repeats ON/OFF operation according to the signal sent from the ECM. The opening of the valve varies for optimum engine control. The optimum value stored in the ECM is determined by considering various engine conditions. When the engine is operating, the flow rate of fuel vapor from the EVAP canister is regulated as the air flow changes.

COMPONENT DESCRIPTION

The EVAP canister purge volume control solenoid valve uses a ON/OFF duty to control the flow rate of fuel vapor from the EVAP canister. The EVAP canister purge volume control solenoid valve is moved by ON/OFF pulses from the ECM. The longer the ON pulse, the greater the amount of fuel vapor that will flow through the valve.

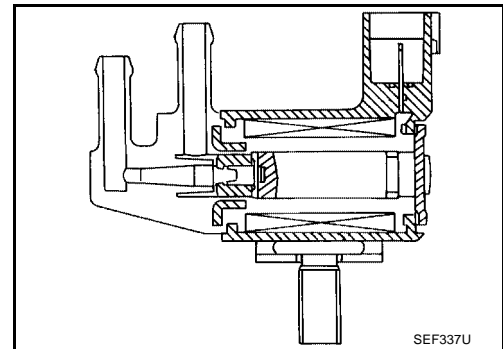

CONSULT-II Reference Value in Data Monitor Mode

UBS00B80

Specification data are reference values.

MONITOR ITEM	CONDITION	SPECIFICATION
PURG VOL C/V	<ul style="list-style-type: none"> ● Engine: After warming up ● Air conditioner switch OFF ● Shift lever: N (A/T), Neutral (M/T) ● No-load 	Idle (Accelerator is not depressed even slightly, after engine starting)
	2,000 rpm	—

10. CHECK FOR EVAP LEAK

⊗ Without CONSULT-II

1. Turn ignition switch OFF.
2. Apply 12 volts DC to EVAP canister vent control valve. The valve will close. (Continue to apply 12 volts until the end of test.)
3. Pressurize the EVAP line using pressure pump with 1.3 to 2.7 kPa (10 to 20 mmHg, 0.39 to 0.79 inHg), then remove pump and EVAP service port adapter.

NOTE:

- Never use compressed air or a high pressure pump.
- Do not exceed 4.12 kPa (0.042 kg/cm² , 0.6 psi) of pressure in the system.

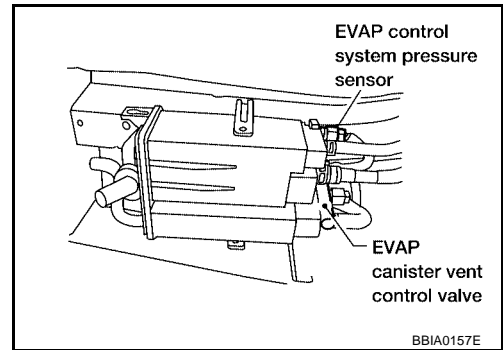

4. Using EVAP leak detector, locate the EVAP leak. For the leak detector, refer to the instruction manual for more details. Refer to [EC-37, "EVAPORATIVE EMISSION LINE DRAWING"](#) .

OK or NG

- OK >> GO TO 12.
 NG >> Repair or replace.

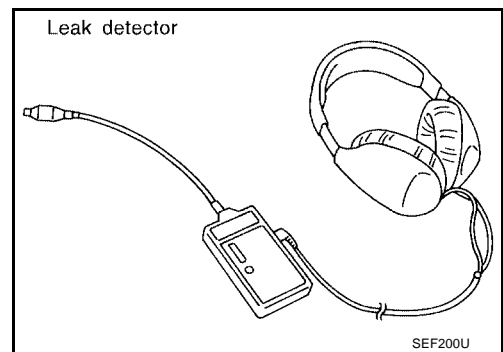

11. CHECK EVAP CANISTER PURGE VOLUME CONTROL SOLENOID VALVE OPERATION

⊕ With CONSULT-II

1. Disconnect vacuum hose to EVAP canister purge volume control solenoid valve at EVAP service port.
2. Start engine.
3. Perform "PURG VOL CONT/V" in "ACTIVE TEST" mode.
4. Touch "Qu" on CONSULT-II screen to increase "PURG VOL CONT/V" opening to 100%.
5. Check vacuum hose for vacuum when revving engine up to 2,000 rpm.

Vacuum should exist.

OK or NG

- OK >> GO TO 14.
 NG >> GO TO 13.

ACTIVE TEST	
PURG VOL CONT/V	XXX %
MONITOR	
ENG SPEED	XXX rpm
A/F ALPHA-B1	XXX %

PBIB1786E

2. CHECK AIR FUEL RATIO (A/F) SENSOR 1 POWER SUPPLY CIRCUIT

1. Disconnect air fuel ratio (A/F) sensor 1 harness connector.
2. Turn ignition switch ON.

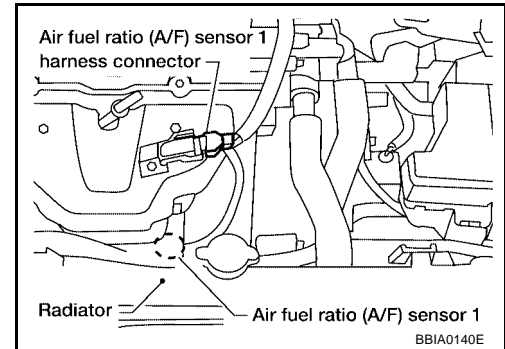

3. Check voltage between A/F sensor 1 terminal 3 and ground with CONSULT-II or tester.

Voltage: Battery voltage

OK or NG

- OK >> GO TO 4.
 NG >> GO TO 3.

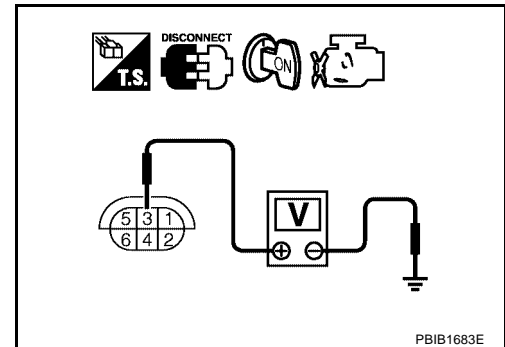

3. DETECT MALFUNCTIONING PART

Check the following.

- Harness connectors M19, E108
- Harness connectors E10, F48
- Fuse block (J/B) connector M1
- 15A fuse
- Harness for open or short between A/F sensor 1 and fuse

>> Repair or replace harness or connectors.

4. CHECK A/F SENSOR 1 HEATER OUTPUT SIGNAL CIRCUIT FOR OPEN AND SHORT

1. Turn ignition switch OFF.
2. Disconnect ECM harness connector.
3. Check harness continuity between ECM terminal 2 and A/F sensor 1 terminal 4. Refer to Wiring Diagram.

Continuity should exist.

4. Also check harness for short to power.

OK or NG

- OK >> GO TO 5.
 NG >> Repair open circuit or short to ground or short to power in harness or connectors.

5. CHECK A/F SENSOR 1 HEATER

Refer to [EC-389, "Component Inspection"](#).

OK or NG

- OK >> GO TO 6.
 NG >> Replace A/F sensor 1.

DTC Confirmation Procedure

NOTE:

If DTC Confirmation Procedure has been previously conducted, always turn ignition switch OFF and wait at least 10 seconds before conducting the next test.

Ⓟ WITH CONSULT-II

1. Turn ignition switch OFF and wait at least 10 seconds.
2. Turn ignition switch ON.
3. Select "DATA MONITOR" mode with CONSULT-II and wait at least 5 seconds.
If 1st trip DTC is detected, go to [EC-426, "Diagnostic Procedure"](#)

DATA MONITOR	
MONITOR	NO DTC
ENG SPEED	XXX rpm

SEF058Y

Ⓟ WITH GST

Follow the procedure "WITH CONSULT-II" above.

A
EC
C
D
E
F
G
H
I
J
K
L
M

DTC P1217 ENGINE OVER TEMPERATURE

[QG18DE]

13. Restart engine and make sure that cooling fan operates at higher speed than low speed.
Be careful not to overheat engine.
14. If NG, go to [EC-460, "Diagnostic Procedure"](#).

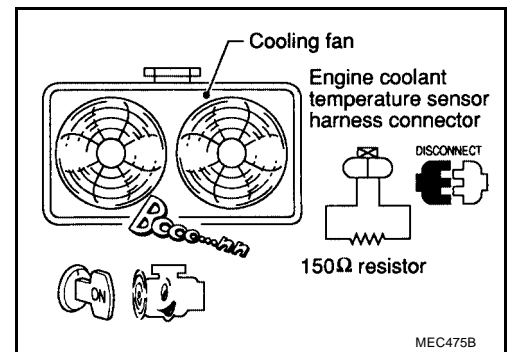

DTC P1273 A/F SENSOR 1

[QG18DE]

If the DTC is displayed, go to [EC-495, "Diagnostic Procedure"](#).

A

EC

C

D

E

F

G

H

I

J

K

L

M

DTC P1444 EVAP CANISTER PURGE VOLUME CONTROL SOLENOID VALVE [QG18DE]

UBS00BEV

On Board Diagnosis Logic

DTC No.	Trouble diagnosis name	DTC detecting condition	Possible cause
P1444 1444	EVAP canister purge volume control solenoid valve	The canister purge flow is detected during the specified driving conditions, even when EVAP canister purge volume control solenoid valve is completely closed.	<ul style="list-style-type: none"> ● EVAP control system pressure sensor ● EVAP canister purge volume control solenoid valve (The valve is stuck open.) ● EVAP canister vent control valve ● EVAP canister ● Hoses (Hoses are connected incorrectly or clogged.)

DTC Confirmation Procedure

UBS00BEW

NOTE:

If DTC Confirmation Procedure has been previously conducted, always turn ignition switch OFF and wait at least 10 seconds before conducting the next test.

TESTING CONDITION:

Always perform test at a temperature of 0°C (32°F) or more.

WITH CONSULT-II

1. Start engine and warm it up to normal operating temperature.
2. Turn ignition switch OFF and wait at least 10 seconds.
3. Turn ignition switch ON.
4. Select "PURG VOL CN/V P1444" of "EVAPORATIVE SYSTEM" in "DTC WORK SUPPORT" mode with CONSULT-II.
5. Touch "START".

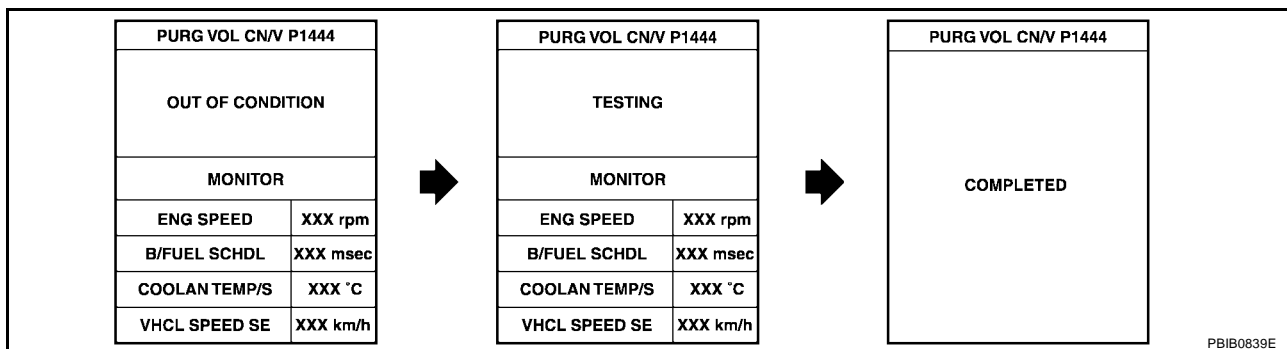

6. Start engine and let it idle until "TESTING" on CONSULT-II changes to "COMPLETED". (It will take approximately 10 seconds.)
If "TESTING" is not displayed after 5 minutes, retry from step 2.
7. Make sure that OK is displayed after touching "SELF-DIAG RESULTS". If NG is displayed, refer to [EC-531, "Diagnostic Procedure"](#).

WITH GST

1. Start engine and warm it up to normal operating temperature.
2. Turn ignition switch OFF and wait at least 10 seconds.
3. Start engine and let it idle for at least 20 seconds.
4. Select Service \$07 with GST.
5. If 1st trip DTC is detected, go to [EC-531, "Diagnostic Procedure"](#).

DTC P1706 PNP SWITCH

PFP:32006

Component Description

UBS00BFP

When the gear position is P or N (A/T models), Neutral (M/T models), park/neutral position (PNP) switch is ON.

ECM detects the park/neutral position when continuity with ground exists.

For A/T models, the park/neutral position (PNP) switch assembly also indicates a transmission range switch to detect selector lever position.

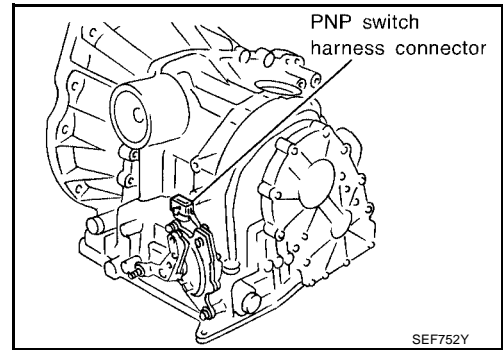

CONSULT-II Reference Value in Data Monitor Mode

UBS00BFQ

Specification data are reference values.

MONITOR ITEM	CONDITION	SPECIFICATION
P/N POSI SW	● Ignition switch: ON	ON
	Except above	OFF

On Board Diagnosis Logic

UBS00BFR

DTC No.	Trouble diagnosis name	DTC detecting condition	Possible cause
P1706 1706	Park/neutral position switch	The signal of the park/neutral position (PNP) switch is not changed in the process of engine starting and driving.	<ul style="list-style-type: none"> ● Harness or connectors [The park/neutral position (PNP) switch circuit is open or shorted.] ● Park/neutral position (PNP) switch

DTC Confirmation Procedure

UBS00BFS

CAUTION:

Always drive vehicle at a safe speed.

NOTE:

If DTC Confirmation Procedure has been previously conducted, always turn ignition switch OFF and wait at least 10 seconds before conducting the next test.

WITH CONSULT-II

1. Turn ignition switch ON.
2. Select "P/N POSI SW" in "DATA MONITOR" mode with CONSULT-II. Then check the "P/N POSI SW" signal under the following conditions.

Position (Selector lever)	Known-good signal
N or P position (A/T models)	ON
Neutral position (M/T models)	ON
Except the above position	OFF

If NG, go to [EC-566. "Diagnostic Procedure"](#) .

If OK, go to following step.

3. Select "DATA MONITOR" mode with CONSULT-II.
4. Start engine and warm it up to normal operating temperature.

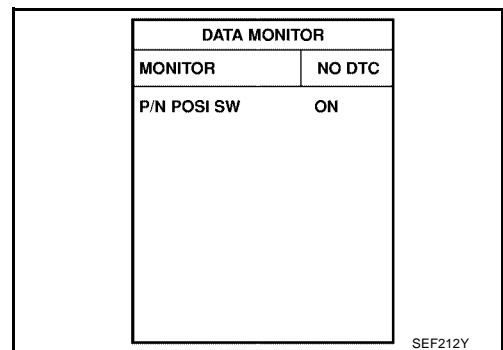

CLICK HERE TO **DOWNLOAD** THE COMPLETE MANUAL

- Thank you very much for reading the preview of the manual.
- You can download the complete manual from: www.heydownloads.com by clicking the link below



- Please note: If there is no response to CLICKING the link, please download this PDF first and then click on it.

CLICK HERE TO **DOWNLOAD** THE COMPLETE MANUAL

2. CHECK APP SENSOR 1 POWER SUPPLY CIRCUIT

1. Disconnect accelerator pedal position (APP) sensor harness connector.
2. Turn ignition switch ON.

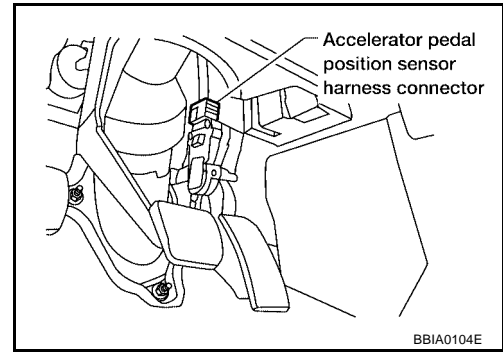

3. Check voltage between APP sensor terminal 2 and ground with CONSULT-II or tester.

Voltage: Approximately 5V

OK or NG

- OK >> GO TO 4.
- NG >> GO TO 3.

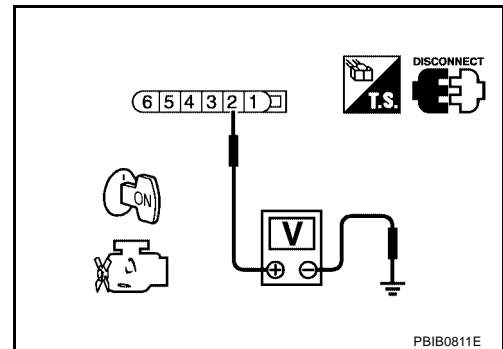

3. DETECT MALFUNCTIONING PART

Check the following.

- Harness connectors M58, F26
- Harness for open or short between ECM and accelerator pedal position sensor

>> Repair open circuit or short to ground or short to power in harness or connectors.

4. CHECK APP SENSOR 2 POWER SUPPLY CIRCUIT-I

Check voltage between APP sensor terminal 1 and ground with CONSULT-II or tester.

Voltage: Approximately 5V

OK or NG

- OK >> GO TO 10.
- NG >> GO TO 5.

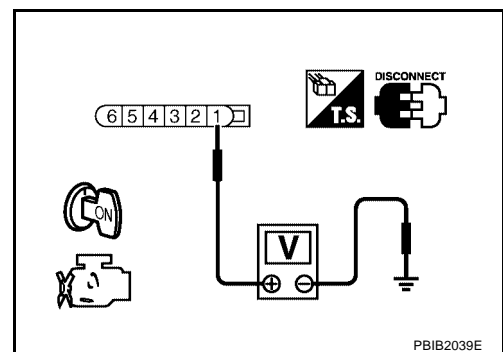

ELECTRICAL LOAD SIGNAL

[QG18DE]

EXCEPT SULEV MODELS

EC-LOAD-01

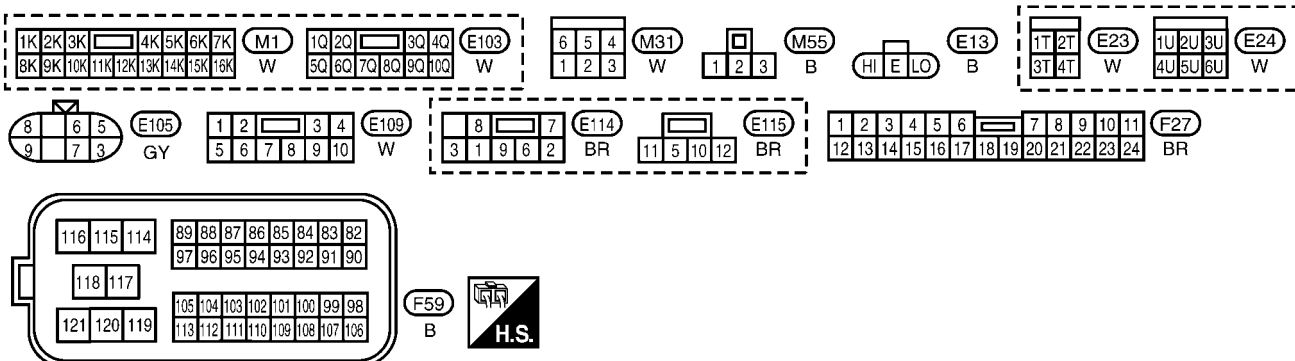
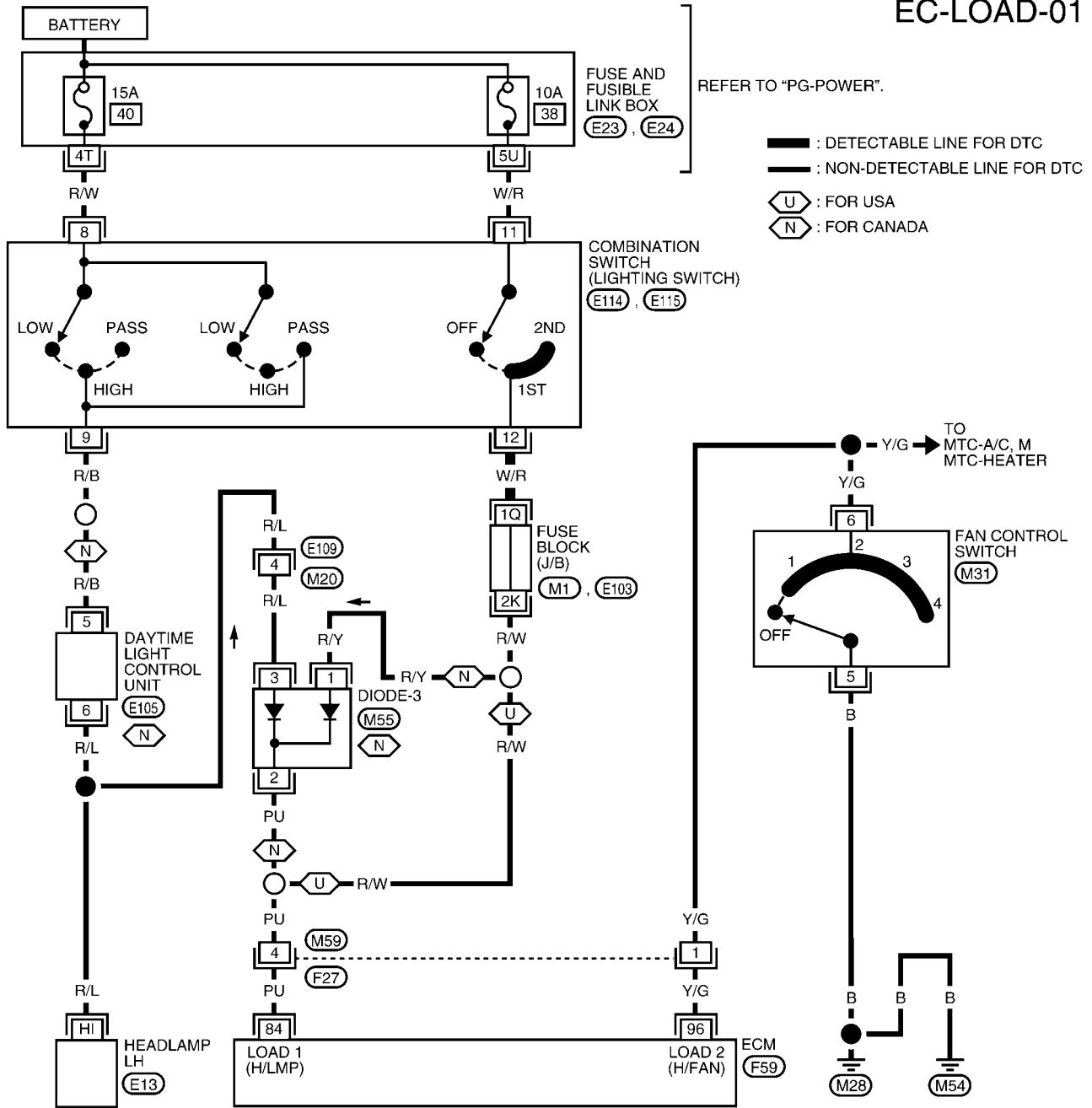

PRECAUTIONS

[QR25DE]

- Do not depress accelerator pedal when starting.
- Immediately after starting, do not rev up engine unnecessarily.
- Do not rev up engine just prior to shutdown.

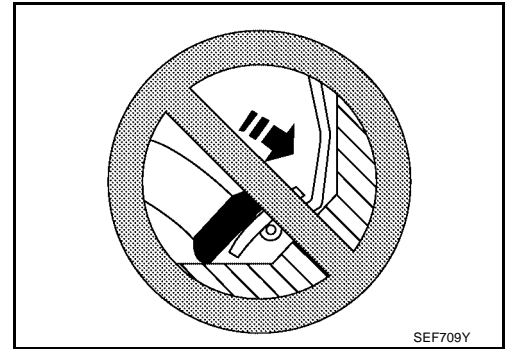

- When installing C.B. ham radio or a mobile phone, be sure to observe the following as it may adversely affect electronic control systems depending on installation location.
 - Keep the antenna as far as possible from the electronic control units.
 - Keep the antenna feeder line more than 20 cm (8 in) away from the harness of electronic controls. Do not let them run parallel for a long distance.
 - Adjust the antenna and feeder line so that the standing-wave ratio can be kept smaller.
 - Be sure to ground the radio to vehicle body.

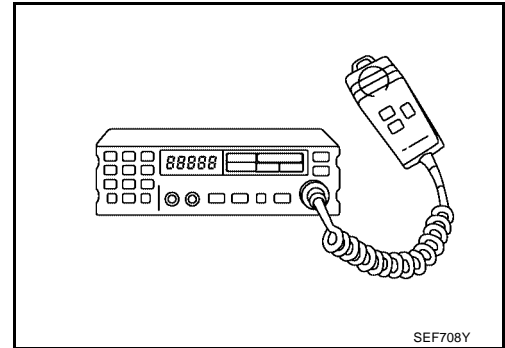

Wiring Diagrams and Trouble Diagnosis

UBS00J8V

When you read wiring diagrams, refer to the following:

- [GI-15, "How to Read Wiring Diagrams"](#)
- [PG-3, "POWER SUPPLY ROUTING"](#) for power distribution circuit

When you perform trouble diagnosis, refer to the following:

- [GI-11, "HOW TO FOLLOW TEST GROUPS IN TROUBLE DIAGNOSES"](#)
- [GI-27, "How to Perform Efficient Diagnosis for an Electrical Incident"](#)

ON BOARD DIAGNOSTIC (OBD) SYSTEM

[QR25DE]

If, during the state emissions inspection, the SRT indicates "CMPLT" for all test items, the inspector will continue with the emissions test. However, if the SRT indicates "INCMP" for one or more of the SRT items the vehicle is returned to the customer untested.

A

NOTE:

If MIL is ON during the state emissions inspection, the vehicle is also returned to the customer untested even though the SRT indicates "CMPLT" for all test items. Therefore, it is important to check SRT ("CMPLT") and DTC (No DTCs) before the inspection.

EC

C

D

E

F

G

H

I

J

K

L

M

31. DETECT MALFUNCTIONING PART

Check the following.

- Check fuel pressure regulator and repair or replace if necessary.
Refer to [EC-753, "FUEL PRESSURE CHECK"](#) .
- Check mass air flow sensor and its circuit, and repair or replace if necessary.
Refer to [EC-861, "DTC P0101 MAF SENSOR"](#) , [EC-870, "DTC P0102, P0103 MAF SENSOR"](#) .
- Check injector and its circuit, and repair or replace if necessary.
Refer to [EC-1336, "INJECTOR CIRCUIT"](#) .
- Check engine coolant temperature sensor and its circuit, and repair or replace if necessary.
Refer to [EC-884, "DTC P0117, P0118 ECT SENSOR"](#) and [EC-897, "DTC P0125 ECT SENSOR"](#) .

OK or NG

- OK >> GO TO 33.
NG >> 1. Repair or replace.
2. GO TO 32.

32. ERASE UNNECESSARY DTC

After this inspection, unnecessary DTC might be displayed.

Erase the stored memory in ECM and TCM.

Refer to [EC-712, "HOW TO ERASE EMISSION-RELATED DIAGNOSTIC INFORMATION"](#) and [AT-428, "HOW TO ERASE DTC"](#) .

>> GO TO 4.

33. CHECK ECM FUNCTION

1. Substitute another known-good ECM to check ECM function. (ECM may be the cause of an incident, but this is a rare case.)
2. Perform initialization of NVIS (NATS) system and registration of all NVIS (NATS) ignition key IDs.
Refer to [BL-96, "NVIS \(NISSAN VEHICLE IMMOBILIZER SYSTEM — NATS\)"](#) .

>> GO TO 4.

Idle Mixture Ratio Adjustment (A/T Models except ULEV)

UBS00J90

PREPARATION

1. Make sure that the following parts are in good order.
 - Battery
 - Ignition system
 - Engine oil and coolant levels
 - Fuses
 - ECM harness connector
 - Vacuum hoses
 - Air intake system
(Oil filler cap, oil level gauge, etc.)
 - Fuel pressure
 - Engine compression
 - Throttle valve
 - Evaporative emission system
2. On air conditioner equipped models, checks should be carried out while the air conditioner is OFF.
3. On automatic transmission equipped models, when checking idle rpm, ignition timing and mixture ratio, checks should be carried out while selector lever is in P or N position.
4. When measuring CO percentage, insert probe more than 40 cm (15.7 in) into tail pipe.
5. Turn OFF headlamps, heater blower, rear window defogger.

TROUBLE DIAGNOSIS

[QR25DE]

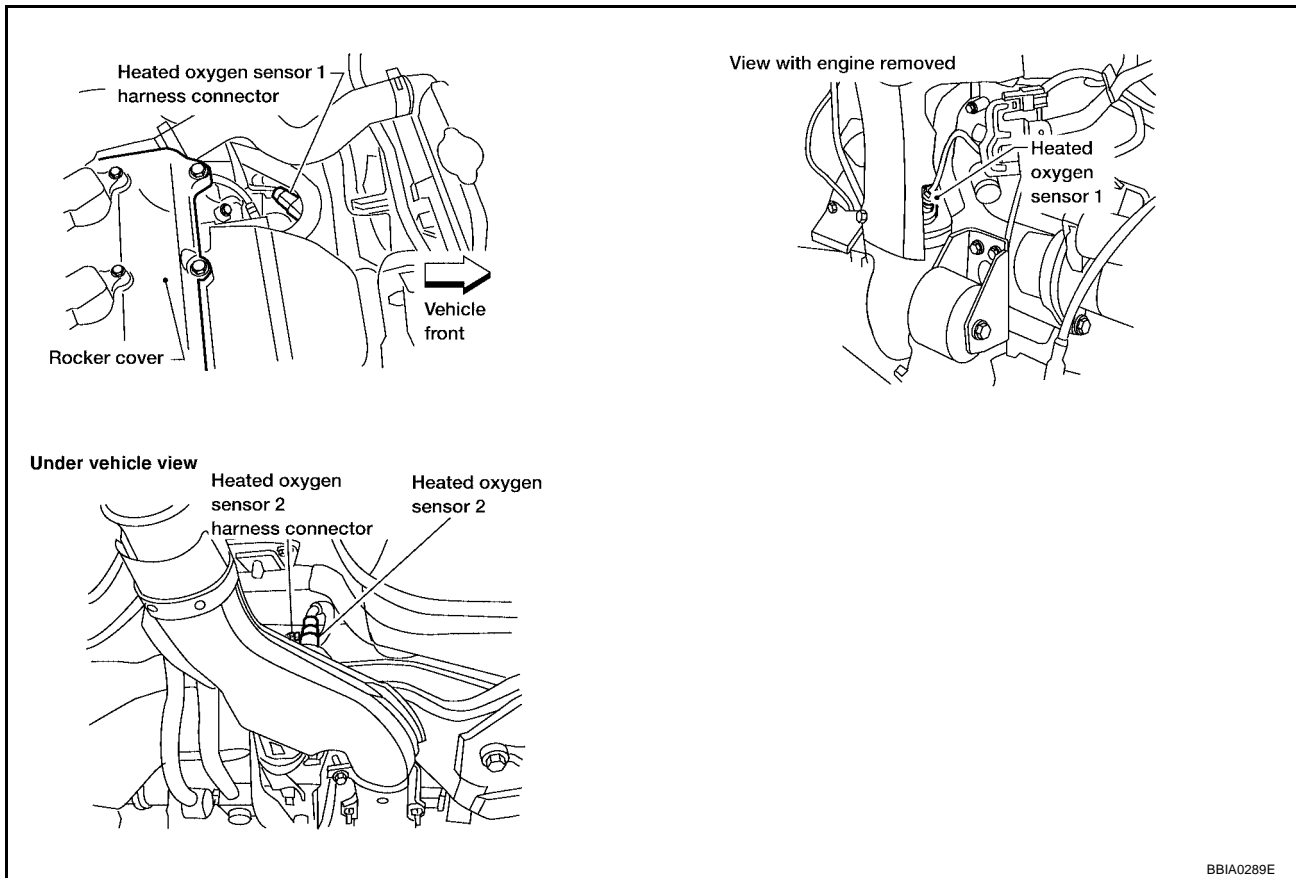
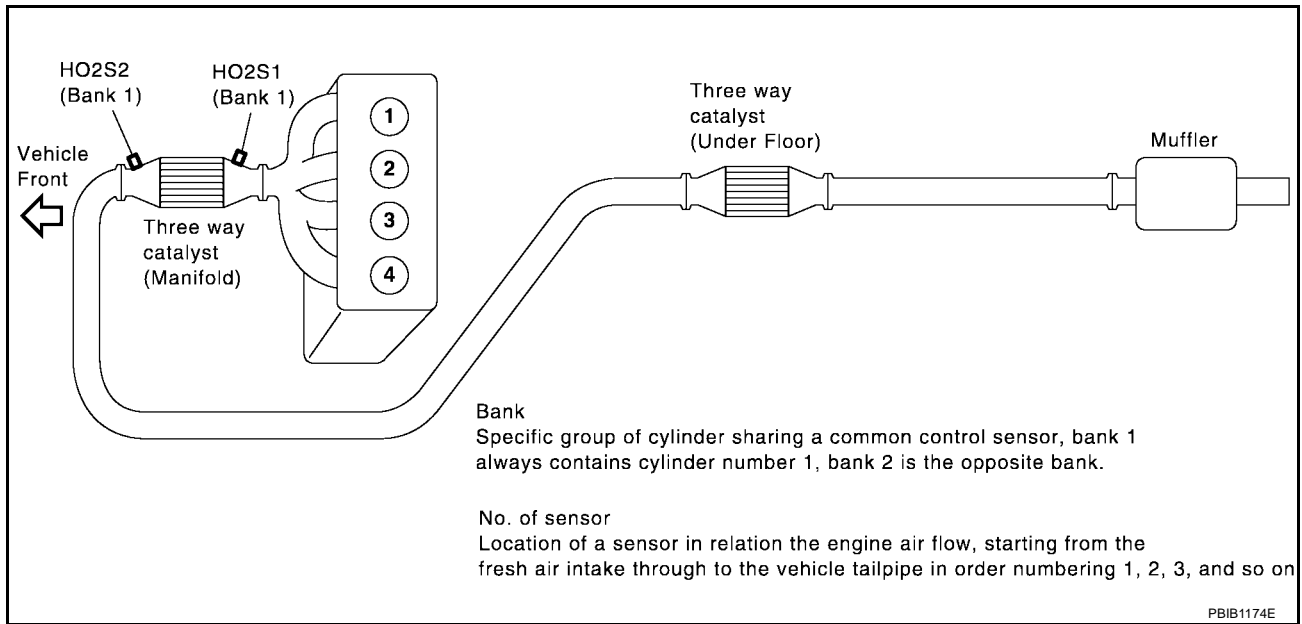

A
EC
C
D
E
F
G
H
I
J
K
L
M

TROUBLE DIAGNOSIS

[QR25DE]

MONITOR ITEM	CONDITION	SPECIFICATION	
START SIGNAL	● Ignition switch: ON → START → ON	OFF → ON → OFF	
CLSD THL POS	● Ignition switch: ON (Engine stopped)	Accelerator pedal: Fully released	ON
		Accelerator pedal: Slightly depressed	OFF
AIR COND SIG	● Engine: After warming up, idle the engine	Air conditioner switch: OFF	OFF
		Air conditioner switch: ON (Compressor operates.)	ON
P/N POSI SW	● Ignition switch: ON	Shift lever: P or N (A/T), Neutral (M/T)	ON
		Shift lever: Except above position	OFF
PW/ST SIGNAL	● Engine: After warming up, idle the engine	Steering wheel is not being turned. (Forward direction)	OFF
		Steering wheel is being turned.	ON
LOAD SIGNAL	● Ignition switch: ON	Rear window defogger switch is ON and/or lighting switch is in 2nd.	ON
		Rear window defogger switch is OFF and lighting switch is OFF.	OFF
IGNITION SW	● Ignition switch: ON → OFF → ON	ON → OFF → ON	
HEATER FAN SW	● Engine: After warming up, idle the engine	Heater fan is operating.	ON
		Heater fan is not operating	OFF
BRAKE SW	● Ignition switch: ON	Brake pedal: Fully released	OFF
		Brake pedal: Slightly depressed	ON
INJ PULSE-B1	● Engine: After warming up ● Shift lever: P or N (A/T), Neutral (M/T) ● Air conditioner switch: OFF ● No-load	Idle	2.0 - 3.0 msec
		2,000 rpm	1.9 - 2.9 msec
IGN TIMING	● Engine: After warming up ● Shift lever: P or N (A/T), Neutral (M/T) ● Air conditioner switch: OFF ● No-load	Idle	10° - 20° BTDC
		2,000 rpm	25° - 45° BTDC
CAL/LD VALUE	● Engine: After warming up ● Shift lever: P or N (A/T), Neutral (M/T) ● Air conditioner switch: OFF ● No-load	Idle	10% - 35%
		2,500 rpm	10% - 35%
MASS AIRFLOW	● Engine: After warming up ● Shift lever: P or N (A/T), Neutral (M/T) ● Air conditioner switch: OFF ● No-load	Idle	1.0 - 4.0 g·m/s
		2,500 rpm	4.0 - 10.0 g·m/s
PURG VOL C/V	● Engine: After warming up ● Shift lever: P or N (A/T), Neutral (M/T) ● Air conditioner switch: OFF ● No-load	Idle (Accelerator pedal is not depressed even slightly, after engine starting)*3	0%
		2,000 rpm	20 - 30%
INT/V TIM (B1)	● Engine: After warming up ● Shift lever: P or N (A/T), Neutral (M/T) ● Air conditioner switch: OFF ● No-load	Idle	-5° - 5°CA
		2,000 rpm	Approx. 0° - 20°CA

DTC U1000, U1001 CAN COMMUNICATION LINE



[QR25DE]

Wiring Diagram

UBS00JAJ

EC-CAN-01

A
EC
C
D
E
F
G
H
I
J
K
L
M

-  : DETECTABLE LINE FOR DTC
-  : NON-DETECTABLE LINE FOR DTC
-  : DATA LINE

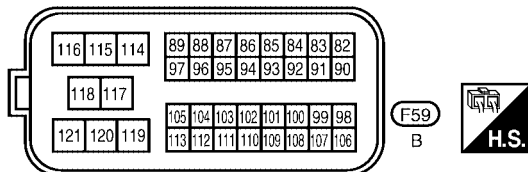
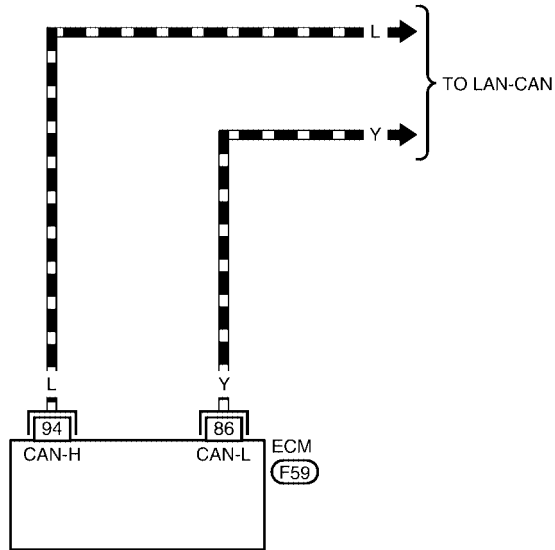

BBWA0274E

DTC P0112, P0113 IAT SENSOR

PF2:22630

Component Description

UBS00JBH

The intake air temperature sensor is built into mass air flow sensor. The sensor detects intake air temperature and transmits a signal to the ECM.

The temperature sensing unit uses a thermistor which is sensitive to the change in temperature. Electrical resistance of the thermistor decreases in response to the temperature rise.

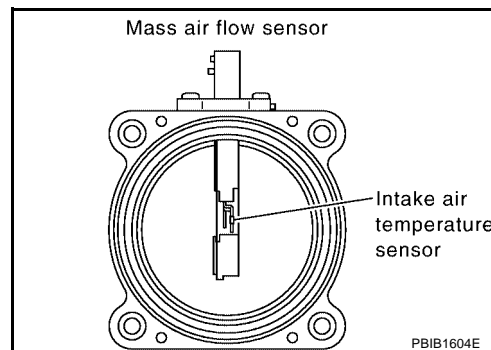

<Reference data>

Intake air temperature °C (°F)	Voltage* V	Resistance kΩ
25 (77)	3.32	1.94 - 2.06
80 (176)	1.23	0.295 - 0.349

*: This data is reference value and is measured between ECM terminal 34 (Intake air temperature sensor) and ground.

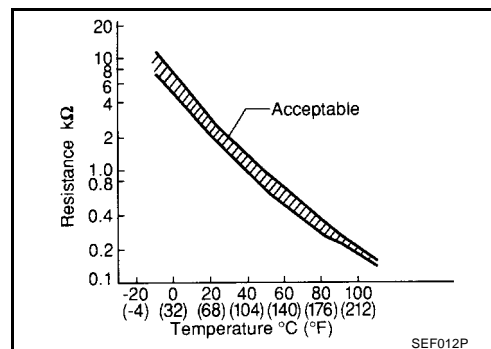

CAUTION:

Do not use ECM ground terminals when measuring input/output voltage. Doing so may result in damage to the ECM's transistor. Use a ground other than ECM terminals, such as the ground.

On Board Diagnosis Logic

UBS00JBI

DTC No.	Trouble diagnosis name	DTC detecting condition	Possible cause
P0112 0112	Intake air temperature sensor circuit low input	An excessively low voltage from the sensor is sent to ECM.	<ul style="list-style-type: none"> ● Harness or connectors (The sensor circuit is open or shorted.) ● Intake air temperature sensor
P0113 0113	Intake air temperature sensor circuit high input	An excessively high voltage from the sensor is sent to ECM.	

DTC Confirmation Procedure

UBS00JBJ

NOTE:

If DTC Confirmation Procedure has been previously conducted, always turn ignition switch OFF and wait at least 10 seconds before conducting the next test.

Ⓟ WITH CONSULT-II

1. Turn ignition switch ON.
2. Select "DATA MONITOR" mode with CONSULT-II.
3. Wait at least 5 seconds.
4. If 1st trip DTC is detected, go to [EC-881, "Diagnostic Procedure"](#)

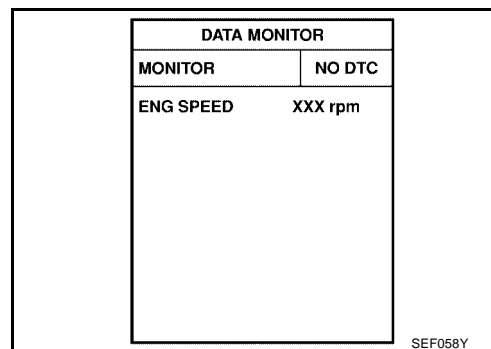

DTC No.	Trouble diagnosis name	DTC detecting condition	Possible cause
P0133 0133	Heated oxygen sensor 1 circuit slow response	The response of the voltage signal from the sensor takes more than the specified time.	<ul style="list-style-type: none"> ● Harness or connectors (The sensor circuit is open or shorted) ● Heated oxygen sensor 1 ● Fuel pressure ● Fuel injector ● Intake air leaks ● Exhaust gas leaks ● PCV valve ● Mass air flow sensor

DTC Confirmation Procedure

UBS00JU3

CAUTION:

Always drive vehicle at a safe speed.

NOTE:

If DTC Confirmation Procedure has been previously conducted, always turn ignition switch OFF and wait at least 10 seconds before conducting the next test.

TESTING CONDITION:

- Always perform at a temperature above -10°C (14°F).
- Before performing the following procedure, confirm that battery voltage is more than 11V at idle.

WITH CONSULT-II

1. Start engine and warm it up to normal operating temperature.
2. Stop engine and wait at least 10 seconds.
3. Turn ignition switch ON and select "HO2S1 (B1) P0133" of "HO2S1" in "DTC WORK SUPPORT" mode with CONSULT-II.
4. Touch "START".
5. Start engine and let it idle for at least 3 minutes.

NOTE:

Never raise engine speed above 3,600 rpm after this step. If the engine speed limit is exceeded, return to step 5.

HO2S1 (B1) P0133	
OUT OF CONDITION	
MONITOR	
ENG SPEED	XXX rpm
B/FUEL SCHDL	XXX msec
COOLAN TEMP/S	XXX °C
VHCL SPEED SEN	XXX km/h

SEF338Z

6. When the following conditions are met, "TESTING" will be displayed on the CONSULT-II screen. Maintain the conditions continuously until "TESTING" changes to "COMPLETED". (It will take approximately 20 to 50 seconds.)

ENG SPEED	1,200 - 3,200 rpm
Vehicle speed	More than 80 km/h (50 MPH)
B/FUEL SCHDL	1.9 - 13.0 msec
Shift lever	Suitable position

HO2S1 (B1) P0133	
TESTING	
MONITOR	
ENG SPEED	XXX rpm
B/FUEL SCHDL	XXX msec
COOLAN TEMP/S	XXX °C
VHCL SPEED SEN	XXX km/h

SEF339Z

If "TESTING" is not displayed after 5 minutes, retry from step 2.

4. CHECK FUEL PRESSURE

1. Release fuel pressure to zero. Refer to [EC-752, "FUEL PRESSURE RELEASE"](#) .
2. Install fuel pressure gauge and check fuel pressure. Refer to [EC-753, "FUEL PRESSURE CHECK"](#) .

At idling: Approximately 350 kPa (3.57 kg/cm² , 51 psi)

OK or NG

- OK >> GO TO 6.
NG >> GO TO 5.

5. DETECT MALFUNCTIONING PART

Check the following.

- Fuel pump and circuit (Refer to [EC-1342, "FUEL PUMP CIRCUIT"](#) .)
- Fuel pressure regulator (Refer to [EC-752, "Fuel Pressure Check"](#) .)
- Fuel lines (Refer to [EM-121, "FUEL INJECTOR AND FUEL TUBE"](#) .)
- Fuel filter for clogging

>> Repair or replace.

6. CHECK MASS AIR FLOW SENSOR

 With CONSULT-II

1. Install all removed parts.
2. Check "MASS AIR FLOW" in "DATA MONITOR" mode with CONSULT-II.

1.4 - 4.0 g-m/sec: at idling

4.0 - 10 g-m/sec: at 2,500 rpm

 With GST

1. Install all removed parts.
2. Check mass air flow sensor signal in Service \$01 with GST.

1.4 - 4.0 g-m/sec: at idling

4.0 - 10 g-m/sec: at 2,500 rpm

OK or NG

- OK >> GO TO 7.
NG >> Check connectors for rusted terminals or loose connections in the mass air flow sensor circuit or ground. Refer to [EC-861, "DTC P0101 MAF SENSOR"](#) .

5. CHECK FUNCTION OF IGNITION COIL-I

CAUTION:

Do the following procedure in the place where ventilation is good without the combustible.

1. Turn ignition switch OFF.
2. Remove fuel pump fuse located in fuse box to release fuel pressure.

NOTE:

Do not use CONSULT-II to release fuel pressure, or fuel pressure applies again during the following procedure.

3. Start engine.
4. After engine stalls, crank it 2 or 3 times to release all fuel pressure.
5. Turn ignition switch OFF.
6. Remove all ignition coil harness connectors to avoid the electrical discharge from the ignition coils.
7. Remove ignition coil and spark plug of the cylinder to be checked.
8. Crank engine for 5 seconds or more to remove combustion gas in the cylinder.
9. Connect spark plug and harness connector to ignition coil.
10. Fix ignition coil using a rope etc. with gap of 13 - 17 mm between the edge of the spark plug and grounded metal portion as shown in the figure.
11. Crank engine for about three seconds, and check whether spark is generated between the spark plug and the grounded metal portion.

Spark should be generated.

CAUTION:

- Do not approach to the spark plug and the ignition coil within 50cm. Be careful not to get an electrical shock while checking, because the electrical discharge voltage becomes 20kV or more.

- It might cause to damage the ignition coil if the gap of 17 mm or more is taken.

NOTE:

When the gap is 13 mm or less, the spark might be generated even if the coil is malfunctioning.

OK or NG

- OK >> GO TO 9.
NG >> GO TO 6.

6. CHECK FUNCTION OF IGNITION COIL-II

1. Turn ignition switch OFF.
2. Disconnect spark plug and connect a known-good spark plug.
3. Crank engine for about 3 seconds, and recheck whether spark is generated between the spark plug and the grounded metal portion.

Spark should be generated.

OK or NG

- OK >> GO TO 7.
NG >> Check ignition coil, power transistor and their circuits. Refer to [EC-1314, "IGNITION SIGNAL"](#).

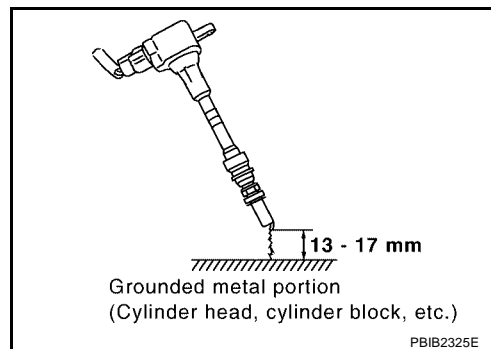
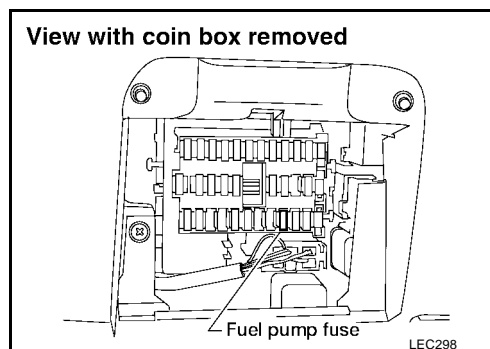

DTC P0441 EVAP CONTROL SYSTEM

[QR25DE]

5. Set voltmeter probes to ECM terminals 32 (EVAP control system pressure sensor signal) and ground.
6. Check EVAP control system pressure sensor value at idle speed and note it.
7. Establish and maintain the following conditions for at least 1 minute.

Air conditioner switch	ON
Headlamp switch	ON
Rear window defogger switch	ON
Engine speed	Approx. 3,000 rpm
Shift lever	Any position other than P, N or R (A/T), Neutral (M/T)

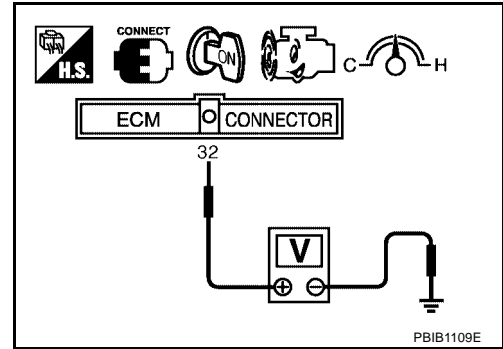

8. Verify that EVAP control system pressure sensor value stays 0.1V less than the value at idle speed (measured at step 6) for at least 1 second.
9. If NG, go to [EC-1018, "Diagnostic Procedure"](#).

Diagnostic Procedure

UBS00JVW

1. CHECK EVAP CANISTER

1. Turn ignition switch OFF.
2. Check EVAP canister for cracks.

OK or NG

- OK (With CONSULT-II) >> GO TO 2.
- OK (Without CONSULT-II) >> GO TO 3.
- NG >> Replace EVAP canister.

2. CHECK PURGE FLOW

With CONSULT-II

1. Disconnect vacuum hose connected to EVAP canister purge volume control solenoid valve at EVAP service port and install vacuum gauge.
2. Start engine and let it idle.
3. Select "PURG VOL CONT/V" in "ACTIVE TEST" mode with CONSULT-II.
4. Rev engine up to 2,000 rpm.

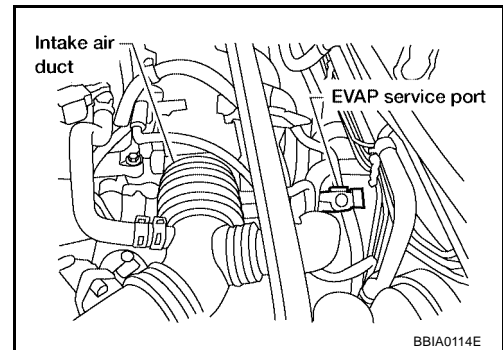

5. Touch "Qd" and "Qu" on CONSULT-II screen to adjust "PURG VOL CONT/V" opening and check vacuum existence.

PURG VOL CONT/V	VACUUM
100%	Should exist.
0%	should not exist.

OK or NG

- OK >> GO TO 7.
- NG >> GO TO 4.

ACTIVE TEST	
PURG VOL CONT/V	XXX %
MONITOR	
ENG SPEED	XXX rpm
A/F ALPHA-B1	XXX %

PBIB1786E

7. CHECK EVAP CONTROL SYSTEM PRESSURE SENSOR INPUT SIGNAL CIRCUIT FOR OPEN AND SHORT

1. Check harness continuity between ECM terminal 32 and EVAP control system pressure sensor terminal 2.
Refer to Wiring Diagram.

Continuity should exist.

2. Also check harness for short to ground and short to power.

OK or NG

- OK >> GO TO 9.
- NG >> GO TO 8.

8. DETECT MALFUNCTIONING PART

Check the following.

- Harness connectors M58, F26
- Harness connectors B1, M14
- Harness for open or short between ECM and EVAP control system pressure sensor

>> Repair open circuit or short to ground or short to power in harness or connectors.

9. CHECK EVAP CONTROL SYSTEM PRESSURE SENSOR

Refer to [EC-1053, "Component Inspection"](#) .

OK or NG

- OK >> GO TO 10.
- NG >> Replace EVAP control system pressure sensor.

10. CHECK INTERMITTENT INCIDENT

Refer to [EC-834, "TROUBLE DIAGNOSIS FOR INTERMITTENT INCIDENT"](#) .

>> INSPECTION END

Component Inspection EVAP CONTROL SYSTEM PRESSURE SENSOR

UBS00JFN

1. Remove EVAP control system pressure sensor with its harness connector connected from EVAP canister.
Do not reuse the O-ring, replace it with a new one.
2. Install a vacuum pump to EVAP control system pressure sensor.
3. Turn ignition switch ON and check output voltage between ECM terminal 32 and ground under the following conditions.

Applied vacuum kPa (mmHg, inHg)	Voltage V
Not applied	1.8 - 4.8
-26.7 (-200, -7.87)	2.1 to 2.5V lower than above value

CAUTION:

- Always calibrate the vacuum pump gauge when using it.
- Do not apply below -93.3 kPa (-700 mmHg, -27.56 inHg) or pressure over 101.3 kPa (760 mmHg, 29.92 inHg).

4. If NG, replace EVAP control system pressure sensor.

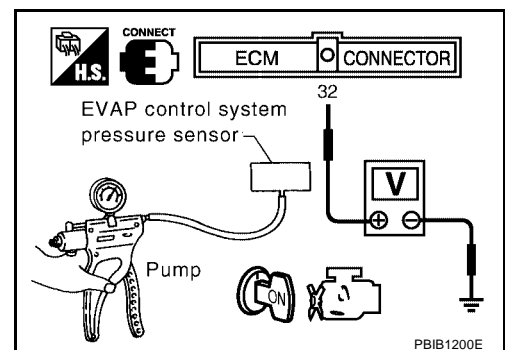

Diagnostic Procedure**1. CHECK INTAKE AIR LEAK**

1. Start engine and let it idle.
2. Listen for an intake air leak after the mass air flow sensor.

OK or NG

- OK >> GO TO 2.
NG >> Discover air leak location and repair.

2. REPLACE ECM

1. Stop engine.
2. Replace ECM.
3. Perform initialization of NVIS (NATS) system and registration of all NVIS (NATS) ignition key IDs. Refer to [EC-696, "NVIS \(NISSAN VEHICLE IMMOBILIZER SYSTEM-NATS\)"](#) .
4. Perform [EC-749, "VIN Registration"](#) .
5. Perform [EC-749, "Accelerator Pedal Released Position Learning"](#) .
6. Perform [EC-749, "Throttle Valve Closed Position Learning"](#) .
7. Perform [EC-750, "Idle Air Volume Learning"](#) .

>> **INSPECTION END**

DTC P1124, P1126 THROTTLE CONTROL MOTOR RELAY

[QR25DE]

UBS00J15

Wiring Diagram

EC-ETC2-01

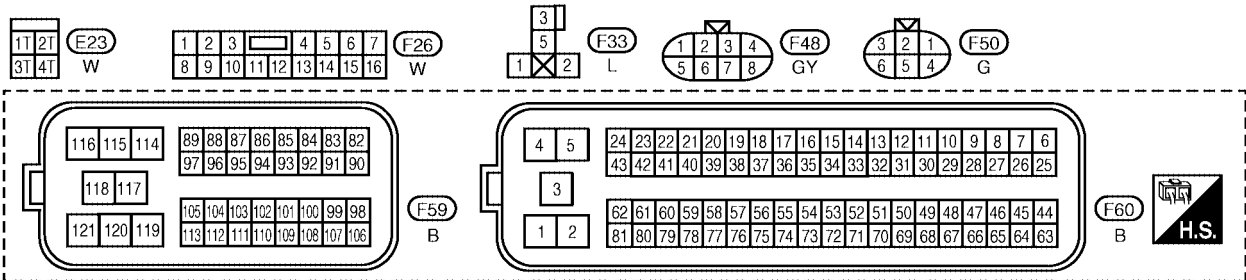
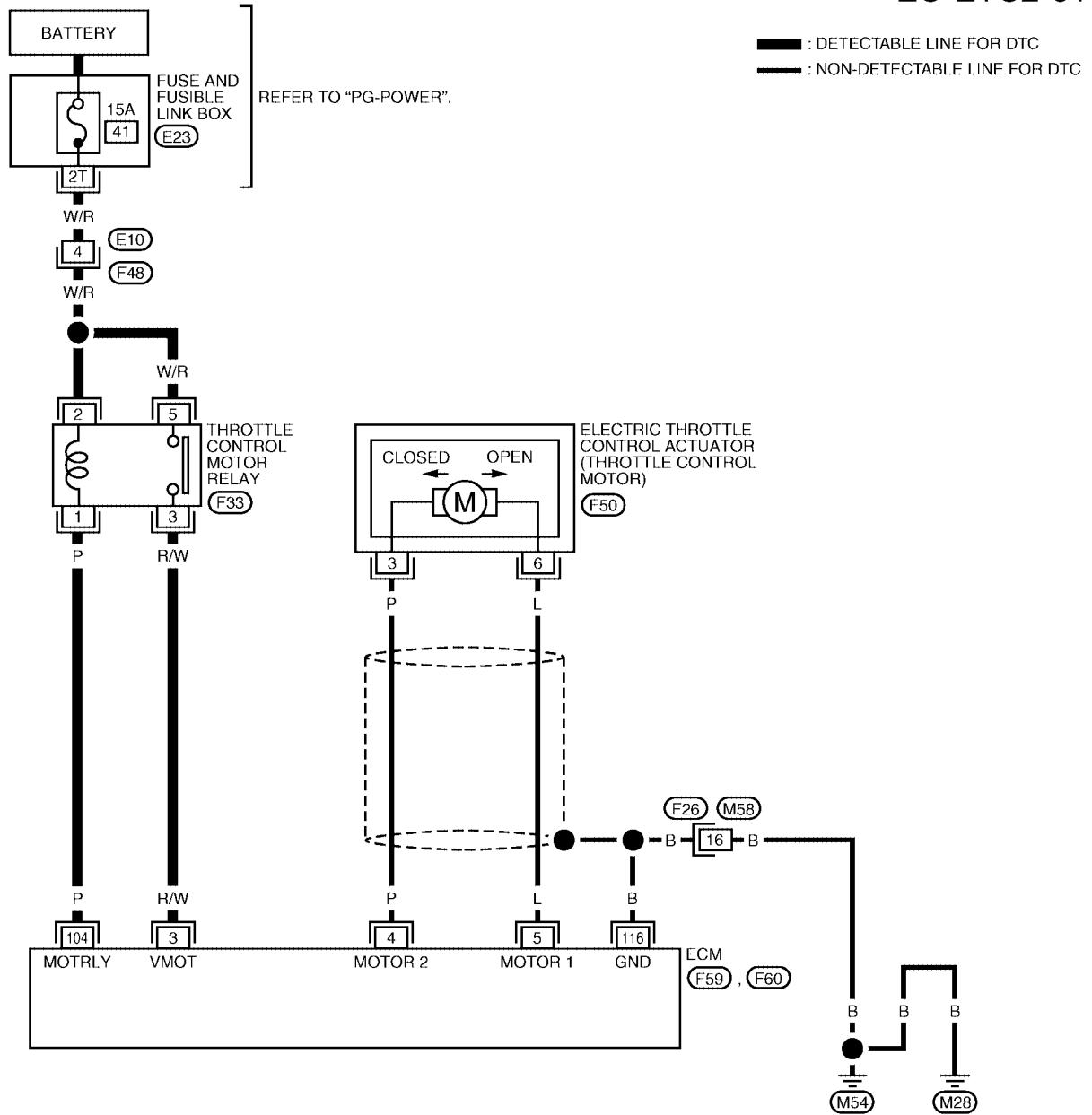

BBWA1467E

6. Check "HO2S2 (B1)" at idle speed when adjusting "FUEL INJECTION" to $\pm 25\%$.

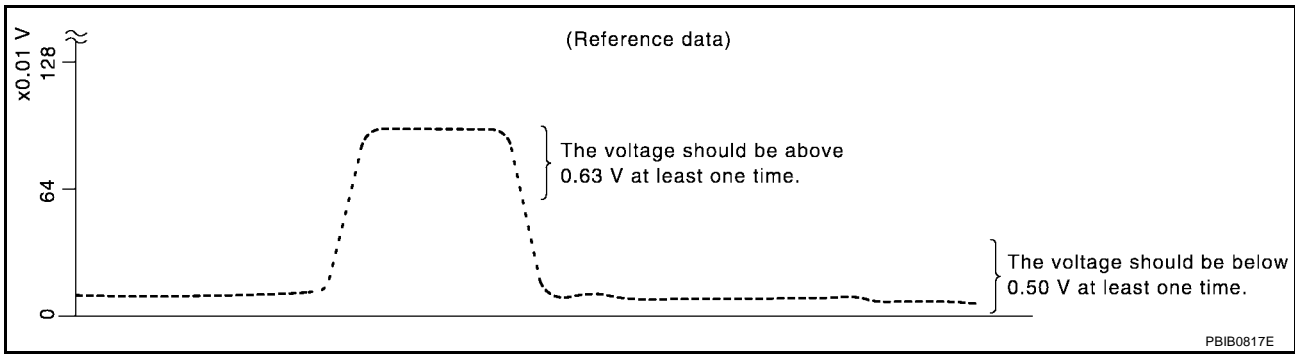

"HO2S2 (B1)" should be above 0.63V at least once when the "FUEL INJECTION" is +25%.
 "HO2S2 (B1)" should be below 0.50V at least once when the "FUEL INJECTION" is -25%.

CAUTION:

- Discard any heated oxygen sensor which has been dropped from a height of more than 0.5 m (19.7 in) onto a hard surface such as a concrete floor; use a new one.
- Before installing new oxygen sensor, clean exhaust system threads using Oxygen Sensor Thread Cleaner tool J-43897-18 or J-43897-12 and approved anti-seize lubricant.

⊗ Without CONSULT-II

1. Start engine and warm it up to the normal operating temperature.
2. Turn ignition switch OFF and wait at least 10 seconds.
3. Start engine and keep the engine speed between 3,500 and 4,000 rpm for at least 1 minute under no load.
4. Let engine idle for 1 minute.
5. Set voltmeter probes between ECM terminal 74 (HO2S2 signal) and ground.
6. Check the voltage when revving up to 4,000 rpm under no load at least 10 times.

(Depress and release accelerator pedal as soon as possible.)
The voltage should be above 0.63V at least once during this procedure.
If the voltage is above 0.63V at step 6, step 7 is not necessary.

7. Keep vehicle idling for 10 minutes, then check voltage. Or check the voltage when coasting from 80 km/h (50 MPH) in D position with "OD" OFF (A/T models) 3rd gear position (M/T models).
The voltage should be below 0.50V at least once during this procedure.

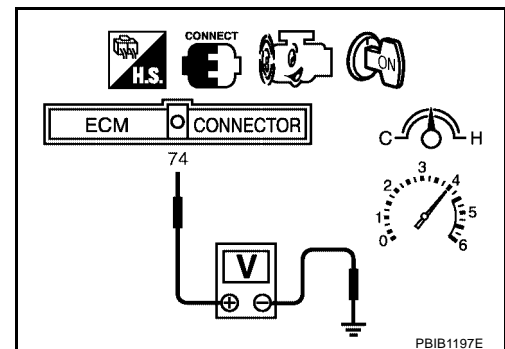

8. If NG, replace heated oxygen sensor 2.

CAUTION:

- Discard any heated oxygen sensor which has been dropped from a height of more than 0.5 m (19.7 in) onto a hard surface such as a concrete floor; use a new one.
- Before installing new oxygen sensor, clean exhaust system threads using Oxygen Sensor Thread Cleaner tool J-43897-18 or J-43897-12 and approved anti-seize lubricant.

**Removal and Installation
 HEATED OXYGEN SENSOR 2**

UBS00JXY

Refer to [EM-113, "EXHAUST MANIFOLD AND THREE WAY CATALYST"](#) .

2. CHECK AIR FUEL RATIO (A/F) SENSOR 1 POWER SUPPLY CIRCUIT

1. Disconnect A/F sensor 1 harness connector.
2. Turn ignition switch ON.

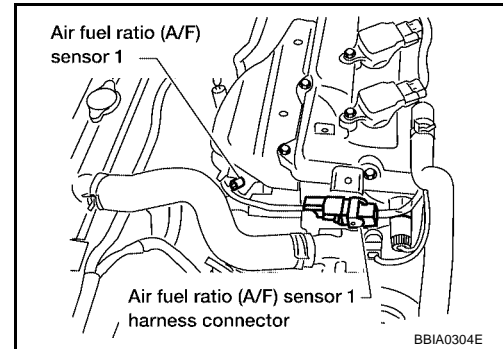

3. Check voltage between A/F sensor 1 terminal 3 and ground with CONSULT-II or tester.

Voltage: Battery voltage

OK or NG

- OK >> GO TO 4.
NG >> GO TO 3.

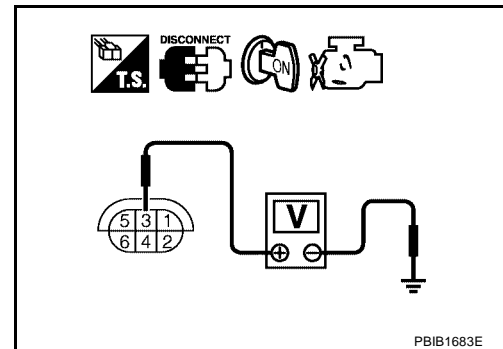

3. DETECT MALFUNCTIONING PART

Check the following.

- Harness connectors M19, E108
- Harness connectors E10, F48
- Fuse block (J/B) connector M1
- 15A fuse
- Harness for open or short between A/F sensor 1 and fuse

>> Repair or replace harness or connectors.

DTC P1279 A/F SENSOR 1

[QR25DE]

UBS00JKU

Wiring Diagram

EC-A/F-01

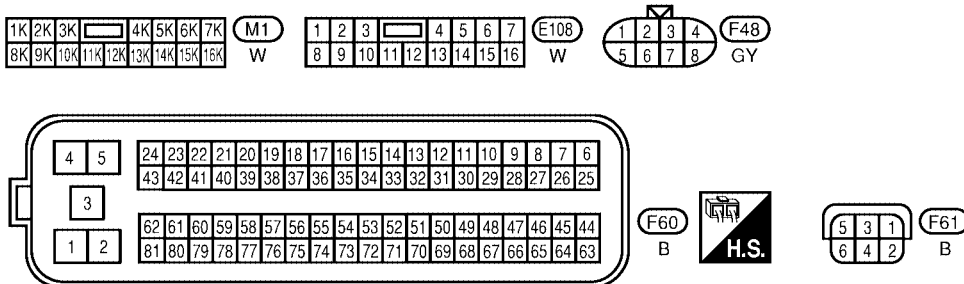
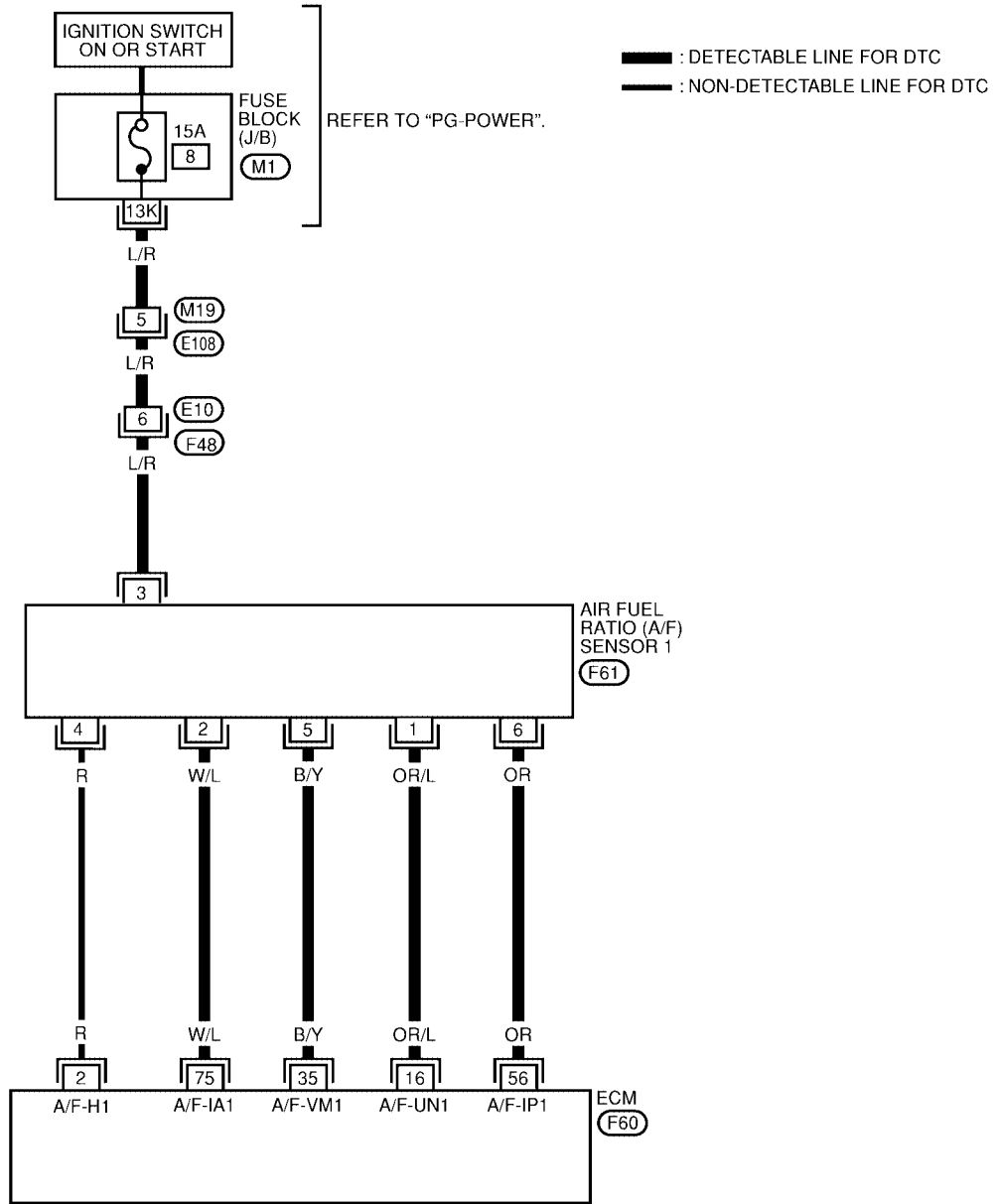

BBWA1478E

7. CHECK ASCD BRAKE SWITCH INPUT SIGNAL CIRCUIT FOR OPEN AND SHORT

1. Turn ignition switch OFF.
2. Disconnect ECM harness connector.
3. Check harness continuity between ECM terminal 108 and ASCD brake switch terminal 2.
Refer to Wiring Diagram.

Continuity should exist.

4. Also check harness for short to ground or short to power.

OK or NG

- OK >> GO TO 9.
NG >> GO TO 8.

8. DETECT MALFUNCTIONING PART

Check the following.

- Harness connectors M59, F27
- Harness for open or short between ECM and ASCD brake switch

>> Repair open circuit or short to ground or short to power in harness or connectors.

9. CHECK ASCD BRAKE SWITCH

Refer to [EC-1265, "Component Inspection"](#) .

OK or NG

- OK >> GO TO 18.
NG >> Replace ASCD brake switch.

10. CHECK ASCD CLUTCH SWITCH INPUT SIGNAL CIRCUIT FOR OPEN AND SHORT

1. Turn ignition switch OFF.
2. Disconnect ECM harness connector.
3. Check harness continuity between ECM terminal 108 and ASCD clutch switch terminal 2.
Refer to Wiring Diagram.

Continuity should exist.

4. Also check harness for short to ground or short to power.

OK or NG

- OK >> GO TO 12.
NG >> GO TO 11.

11. DETECT MALFUNCTIONING PART

Check the following.

- Harness connectors M59, F27
- Harness for open or short between ECM and ASCD clutch switch

>> Repair open circuit or short to ground or short to power in harness or connectors.

12. CHECK ASCD CLUTCH SWITCH

Refer to [EC-1265, "Component Inspection"](#) .

OK or NG

- OK >> GO TO 18.
NG >> Replace ASCD clutch switch.

Component Inspection

ACCELERATOR PEDAL POSITION SENSOR

1. Reconnect all harness connectors disconnected.
2. Turn ignition switch ON.
3. Check voltage between ECM terminals 106 (APP sensor 1 signal), 98 (APP sensor 2 signal) and ground under the following conditions.

Terminal	Accelerator pedal	Voltage
106 (Accelerator pedal position sensor 1)	Fully released	0.65 - 0.87V
	Fully depressed	More than 4.3V
98 (Accelerator pedal position sensor 2)	Fully released	0.28 - 0.48V
	Fully depressed	More than 2.0V

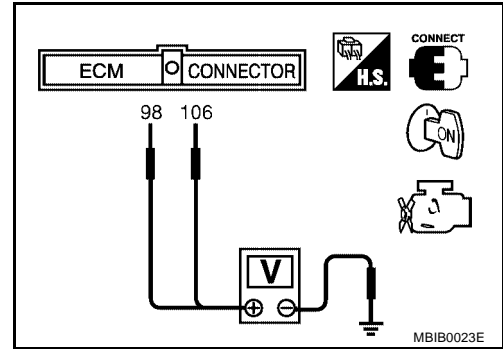

4. If NG, replace accelerator pedal assembly and go to the next step.
5. Perform [EC-749, "Accelerator Pedal Released Position Learning"](#) .
6. Perform [EC-749, "Throttle Valve Closed Position Learning"](#) .
7. Perform [EC-750, "Idle Air Volume Learning"](#) .

Remove and Installation

ACCELERATOR PEDAL

Refer to [ACC-2, "ACCELERATOR CONTROL SYSTEM"](#) .

6. CHECK VIAS CONTROL SOLENOID VALVE POWER SUPPLY CIRCUIT-I

1. Turn ignition switch OFF.
2. Disconnect VIAS control solenoid valve harness connector.
3. Turn ignition switch ON.

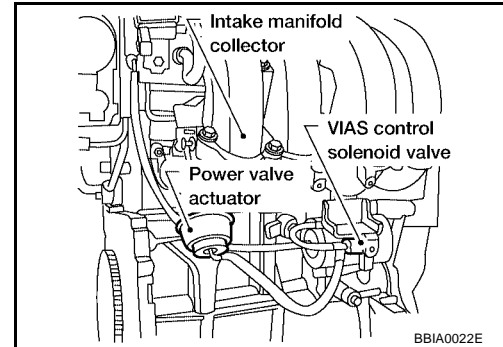

4. Check voltage between VIAS control solenoid valve terminal 1 and ground with CONSULT-II or tester.

Voltage: Battery voltage

OK or NG

- OK >> GO TO 8.
NG >> GO TO 7.

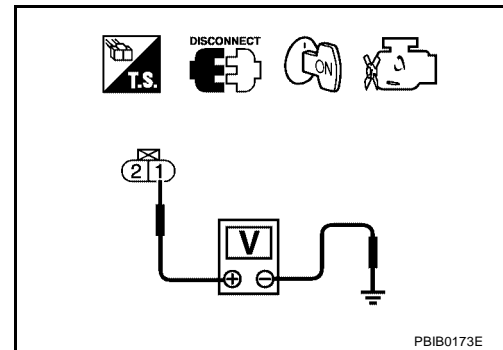
**7. CHECK VIAS CONTROL SOLENOID VALVE POWER SUPPLY CIRCUIT-II**

1. Turn ignition switch OFF.
2. Disconnect ECM relay.
3. Check harness continuity between ECM relay terminal 7 and VIAS control solenoid valve terminal 1. Refer to Wiring Diagram.

Continuity should exist.

4. Also check harness for short to ground and short to power.

OK or NG

- OK >> GO TO 8.
NG >> Repair open circuit or short to ground or short to power in harness or connectors.

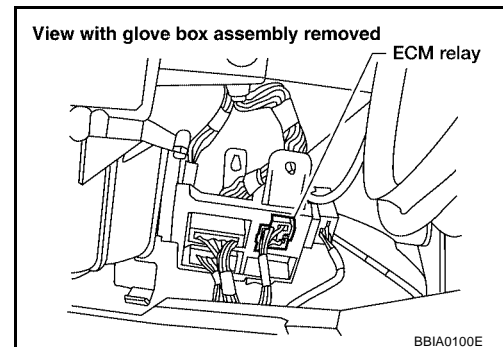
**8. CHECK VIAS CONTROL SOLENOID VALVE POWER SUPPLY CIRCUIT-III**

Check voltage between ECM relay terminal 6 and ground with CONSULT-II or tester.

Voltage: Battery voltage

OK or NG

- OK >> GO TO 10.
NG >> GO TO 9.

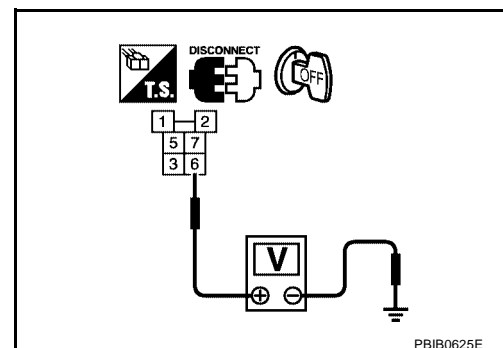

13. CHECK HEATER FAN SWITCH FUNCTION

1. Turn the fan control switch ON in any position.
2. Check that heater fan turns properly.

OK or NG

- OK >> GO TO 14.
NG >> Refer to [MTC-19, "TROUBLE DIAGNOSIS"](#)

14. CHECK HEATER FAN INPUT SIGNAL CIRCUIT FOR OPEN AND SHORT

1. Turn ignition switch OFF.
2. Disconnect ECM harness connector.
3. Disconnect air control harness connector.
4. Check harness continuity between ECM terminal 96 and air control terminal 8, fan control switch terminal 6.
Refer to Wiring Diagram.

Continuity should exist.

5. Also check harness for short to ground and short to power.

OK or NG

- OK >> GO TO 19.
NG >> GO TO 15.

15. DETECT MALFUNCTIONING PART

Check the following.

- Harness connectors M59, F27
- Harness for open or short between ECM and air control.
- Harness for open or short between ECM and fan control switch.

>> Repair open circuit or short to ground or short to power in harness or connectors.

16. CHECK REAR WINDOW DEFOGGER FUNCTION

1. Turn ignition switch OFF.
2. Turn ON the rear window defogger switch.
3. Check the rear windshield. Is the rear windshield and door mirror (with heated mirror models) heated up?

Yes or No

- Yes >> GO TO 17.
No >> Refer to [GW-17, "REAR WINDOW DEFOGGER"](#)

17. CHECK REAR WINDOW DEFOGGER INPUT SIGNAL CIRCUIT FOR OPEN AND SHORT

1. Disconnect ECM harness connector.
2. Disconnect rear window defogger relay.
3. Check harness continuity between ECM terminal 93 and rear window defogger relay terminals 5, 7.
Refer to Wiring Diagram.

Continuity should exist.

4. Also check harness for short to ground and short to power.

OK or NG

- OK >> GO TO 19.
NG >> GO TO 18.

BODY FRONT END

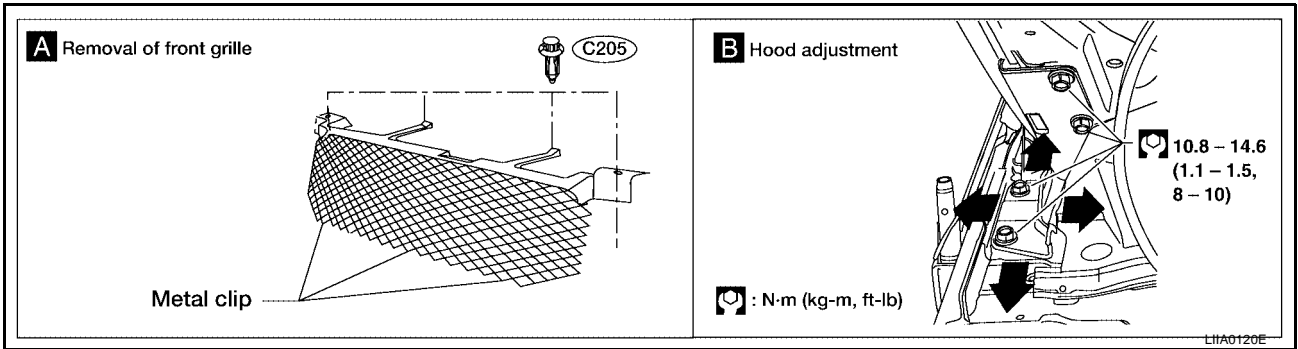

A

B

C

D

E

F

G

H

EI

J

K

L

M

OIL PAN

Components

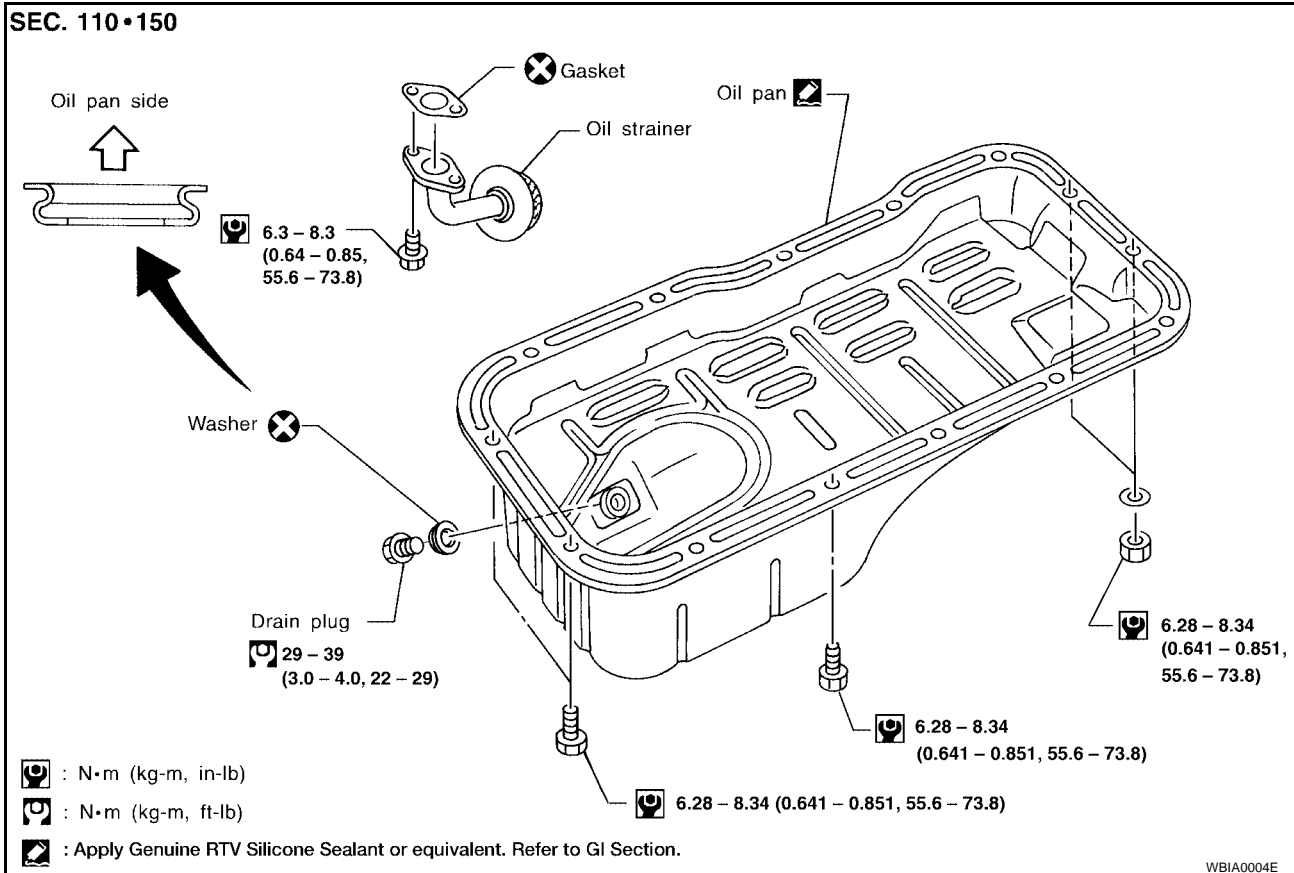

Removal

1. Remove engine RH side undercover splash shield.
2. Drain engine oil. Refer to [MA-20, "Changing Engine Oil"](#) .
3. Remove front exhaust tube. Refer to [EX-3, "Removal and Installation"](#) .
4. Remove the exhaust manifold support.
5. Remove the engine gusset.

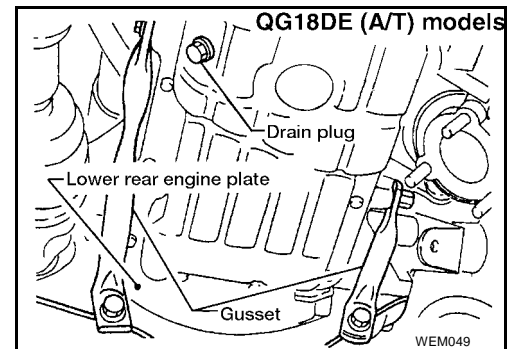

OIL SEAL

[QG18DE]

3. Apply new engine oil to new oil seal and install it using a suitable tool.
 - Install new oil seal in the direction shown.

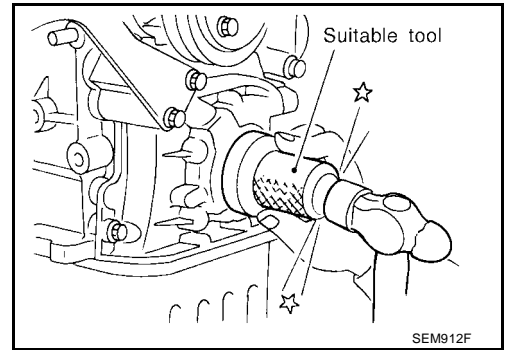
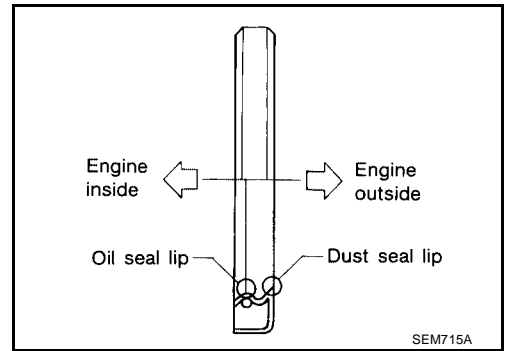

A

EM

C

D

E

F

G

H

I

J

K

L

M

SERVICE DATA AND SPECIFICATIONS (SDS)

[QG18DE]

2.66 (0.1047)	266
2.68 (0.1055)	268
2.70 (0.1063)	270
2.72 (0.1071)	272
2.74 (0.1079)	274
2.76 (0.1087)	276
2.78 (0.1094)	278
2.80 (0.1102)	280
2.82 (0.1110)	282
2.84 (0.1118)	284
2.86 (0.1126)	286
2.88 (0.1134)	288
2.90 (0.1142)	290
2.92 (0.1150)	292
2.94 (0.1157)	294
2.96 (0.1165)	296
2.98 (0.1173)	298

VALVE SEAT

Unit: mm (in)

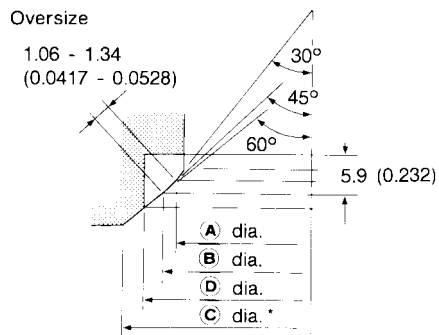
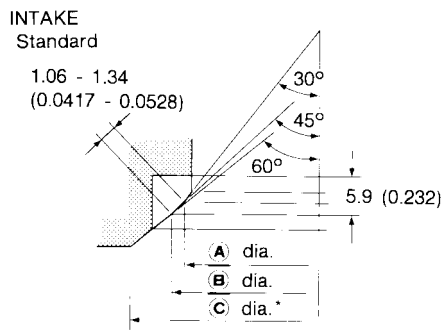

*Cylinder head machining data SEM573DA

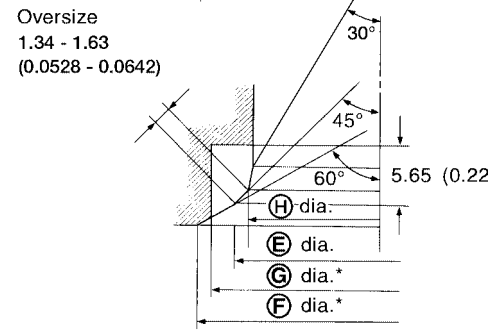
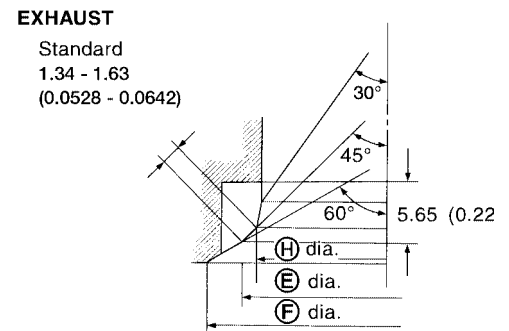

* Cylinder head machining data SEM047

Dia.	Specification	Dia.	Specification
A	27.8 - 28.0 (1.094 - 1.102)	E	24.5 - 24.7 (0.965 - 0.972)
B	29.5 - 29.7 (1.161 - 1.169)	F	26.500 - 26.516 (1.0433 - 1.0439)
C	31.9 - 32.1 (1.256 - 1.264)	G	26.2 - 26.4 (1.031 - 1.039)
D	31.500 - 31.516 (1.2402 - 1.2408)	H	22.4 - 22.6 (0.8819 - 0.8898)

FUEL INJECTOR AND FUEL TUBE

[QR25DE]

- b. Tighten the fuel tube bolts in two steps in the numerical order shown.

Step 1 : 12 - 13 N·m (1.2 - 1.4 kg-m, 105 - 121 in-lb)

Step 2 : 17 - 23 N·m (1.7 - 2.4 kg-m, 13 - 17 ft-lb)

CAUTION:

After properly connecting fuel tube assembly to injector and fuel hose, check connection for fuel leakage.

5. Connect the fuel hose quick connector. Refer to [EM-108, "INTAKE MANIFOLD"](#).
6. Install the intake collector. Refer to [EM-108, "INTAKE MANIFOLD"](#).
7. Installation of the remaining components is in reverse order of removal.

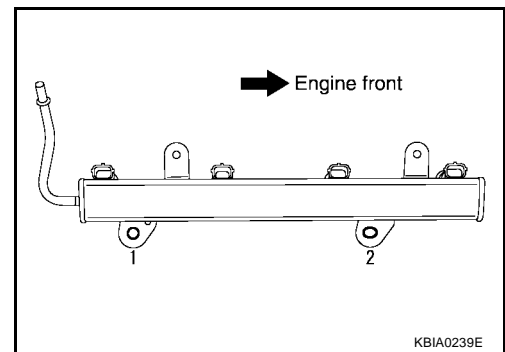

INSPECTION AFTER INSTALLATION

Make sure there is no fuel leakage at connections as follows:

1. Apply fuel pressure to fuel lines by turning ignition switch ON (with engine stopped). Then check for fuel leaks at connections.
2. Start the engine and rev it up and check for fuel leaks at connections.

NOTE:

Use mirrors for checking on connections out of the direct line of sight.

CAUTION:

Do not touch engine immediately after stopping as engine is extremely hot.

- Perform procedures for "Throttle Valve Closed Position Learning" after finishing repairs. Refer to [EC-749, "Throttle Valve Closed Position Learning"](#).
- If electric throttle control actuator is replaced, perform procedures for "Idle Air Volume Learning" after finishing repairs. Refer to [EC-750, "Idle Air Volume Learning"](#).

CYLINDER HEAD

[QR25DE]

VALVE SPRING DIMENSIONS AND VALVE SPRING PRESSURE LOAD

Check valve spring pressure with valve spring seat installed at specified spring height. Replace if not within specifications.

CAUTION:

Do not remove the valve spring seat.

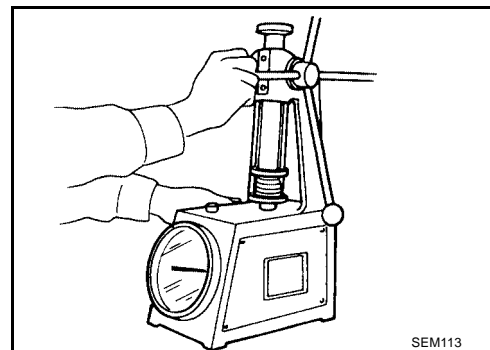

STANDARD	INTAKE (identification color: blue)	EXHAUST (identification color: yellow)
Free height	44.84 - 45.34 mm (1.7654 - 1.7850 in)	45.28 - 45.78 mm (1.7827 - 1.8024 in)
Installation height	35.30 mm (1.390 in)	35.30 mm (1.390 in)
Installation load	151 - 175 N (15.4 - 17.8 kg-force, 34 - 39 lb-force)	151 - 175 N (15.4 - 17.8 kg-force, 34 - 39 lb-force)
Height during valve open	24.94 mm (0.9819 in)	26.39 mm (1.0390 in)
Load with valve open	358 - 408 N (36.5 - 41.6 kg-force, 80 - 92 lb-force)	325 - 371 N (33.1 - 37.8 kg-force, 73 - 83 lb-force)

SERVICE DATA AND SPECIFICATIONS (SDS)

[QR25DE]

Cylinder head seat recess diameter (D)	Intake	36.500 - 36.516 (1.4370 - 1.4376)	37.000 - 37.016 (1.4567 - 1.4573)
	Exhaust	31.500 - 31.516 (1.2402 - 1.2408)	32.000 - 32.016 (1.2598 - 1.2605)
Valve seat interference fit	Intake	0.081 - 0.113 (0.0032 - 0.0044)	
	Exhaust	0.084 - 0.116 (0.0033 - 0.0046)	
Valve seat outer diameter (d)	Intake	36.597 - 36.613 (1.4408 - 1.4415)	37.097 - 37.113 (1.4605 - 1.4611)
	Exhaust	31.600 - 31.616 (1.2441 - 1.2447)	32.100 - 32.116 (1.2638 - 1.2644)

CAMSHAFT AND CAMSHAFT BEARING

Unit: mm (in)

	Standard
Camshaft runout [TIR*]	Less than 0.04 (0.0016)

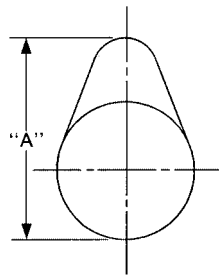

SEM671

Cam height "A"	Intake	45.665 - 45.855 (1.7978 - 1.8053)
	Exhaust	43.975 - 44.165 (1.7313 - 1.7388)
Outer diameter of camshaft journal	No. 1	27.935 - 27.955 (1.0998 - 1.1006)
	No. 2, 3, 4, 5	23.435 - 23.455 (0.9226 - 0.9234)
Inner diameter of camshaft bracket	No.1	28.000 - 28.021 (1.1024 - 1.1032)
	No.2, 3, 4, 5	23.500 - 23.521 (0.9252 - 0.9260)
Camshaft journal clearance		0.045 - 0.086 (0.0018 - 0.0034)
Camshaft end play		0.115 - 0.188 (0.0045 - 0.0074)
Camshaft sprocket runout [TIR*]		Less than 0.15 (0.0059)

*: Total indicator reading

CYLINDER BLOCK

Unit: mm (in)

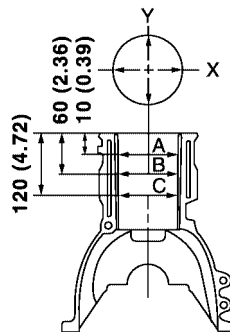

PBIC0281E

Surface distortion	Limit			0.1 (0.004)
Cylinder bore	Inner diameter	Standard	Grade No. 2	89.010 - 89.020 (3.5043 - 3.5047)
			Grade No. 3	89.020 - 89.030 (3.5047 - 3.5051)
		Wear limit		0.2 (0.008)

SERVICE DATA AND SPECIFICATIONS (SDS)

HOW TO USE THIS MANUAL

EAS00177

GI

Relation between Illustrations and Descriptions

The following sample explains the relationship between the part description in an illustration, the part name in the text and the service procedures.

< Example 1 >

1. Remove return spring (1) from parking pawl (2).

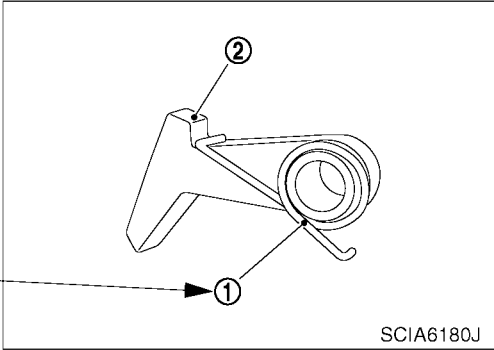

The identifier number of the part name in the text is consistent with the identifier part number in the illustration.

SCIA6180J

Direction mark

< Example 2 >

-  : Vehicle front
- Tighten rear member mounting bolts following the numerical order shown in the illustration.
- Note : View upward

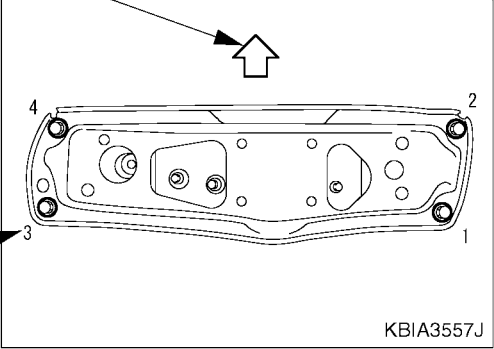

The numbers in the illustration are consistent with the service operation instructions.

KBIA3557J

SAIA0519E

B

C

D

E

F

G

H

I

J

K

L

M

TOW TRUCK TOWING

Vehicle Recovery (Freeing a stuck vehicle)

EAS000VX

- Tow chains or cables must be attached only to the main structural members of the vehicle.
- Pulling devices should be routed so they do not touch any part of the suspension, steering, brake or cooling systems.
- Always pull the cable straight out from the front of the vehicle. Never pull on the vehicle at an angle.
- Pulling devices such as ropes or canvas straps are not recommended for use in vehicle towing or recovery.

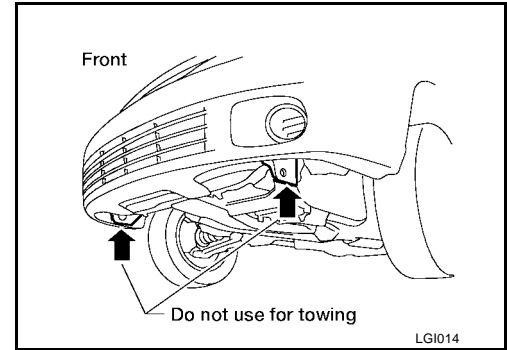

REAR WINDOW DEFOGGER

- Turn ignition switch ON.
- Touch "START (NISSAN BASED VHCL)".

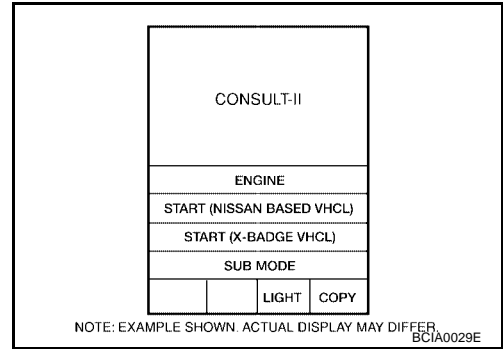

- Touch "SMART ENTRANCE".
If "SMART ENTRANCE" is not indicated, go to [GI-39, "CONSULT-II Data Link Connector \(DLC\) Circuit"](#).

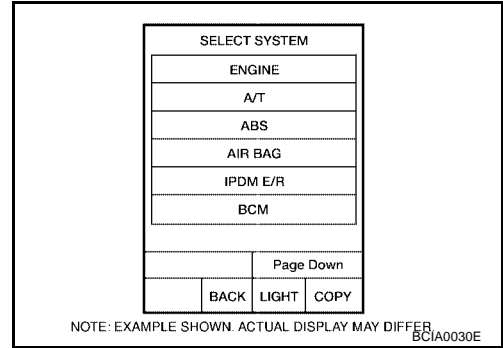

- Touch "REAR WINDOW DEFOGGER".

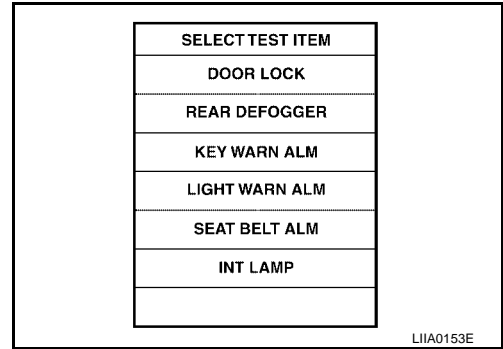

- Select diagnosis mode, "DATA MONITOR" and "ACTIVE TEST".

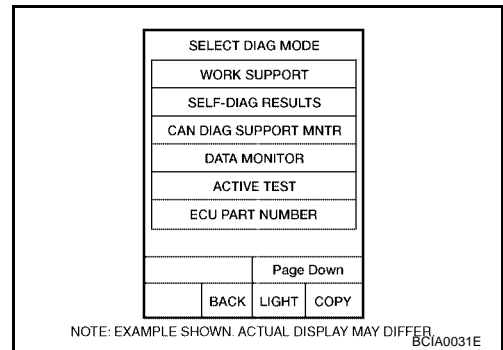

CONSULT-II Application Items (With Power Door Locks) "REAR DEFOGGER"

EIS00168

Data Monitor

Monitored Item	Description
IGN ON SW	Indicates [ON/OFF] condition of ignition switch.
REAR DEF SW	Indicates [ON/OFF] condition of rear window defogger switch.

PRECAUTIONS

Precautions for Supplemental Restraint System (SRS) “AIR BAG” and “SEAT BELT PRE-TENSIONER”

UKS0024Z

The Supplemental Restraint System such as “AIR BAG” and “SEAT BELT PRE-TENSIONER”, used along with a front seat belt, helps to reduce the risk or severity of injury to the driver and front passenger for certain types of collision. Information necessary to service the system safely is included in the SRS and SB section of this Service Manual.

WARNING:

- To avoid rendering the SRS inoperative, which could increase the risk of personal injury or death in the event of a collision which would result in air bag inflation, all maintenance must be performed by an authorized NISSAN/INFINITI dealer.
- Improper maintenance, including incorrect removal and installation of the SRS, can lead to personal injury caused by unintentional activation of the system. For removal of Spiral Cable and Air Bag Module, see the SRS section.
- Do not use electrical test equipment on any circuit related to the SRS unless instructed to in this Service Manual. SRS wiring harnesses can be identified by yellow and/or orange harnesses or harness connectors.

**Precautions For Trouble Diagnosis
CAN SYSTEM**

UKS00250

- Do not apply voltage of 7.0 V or higher to the measurement terminals.
- Use the tester with its open terminal voltage being 7.0 V or less.

**Precautions For Harness Repair
CAN SYSTEM**

UKS00251

- Solder the repaired parts, and wrap with tape. [Frays of twisted line must be within 110 mm (4.33 in).]

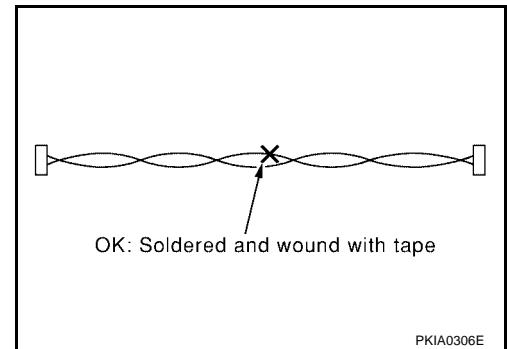

- Do not perform bypass wire connections for the repair parts. (The spliced wire will become separated and the characteristics of twisted line will be lost.)

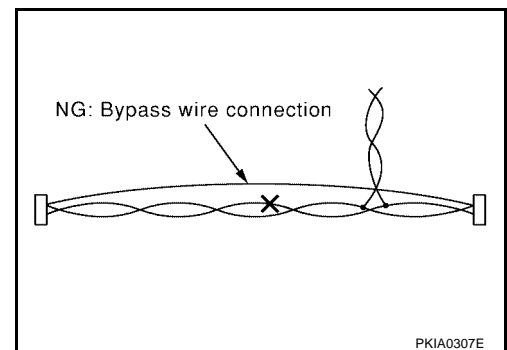

HEADLAMP (FOR CANADA) — DAYTIME LIGHT SYSTEM —

- to LH headlamp terminal E
- from daytime light control unit terminal 7
- through daytime light control unit terminal 9
- through body grounds E7 and E37.

With power and ground supplied, the low beam headlamps illuminate.

High Beam Operation/Flash-to-pass Operation

When the lighting switch is moved to headlamp "ON" (2ND) position, "HIGH BEAM" (A) or "FLASH TO PASS" (C) position, power is supplied

- from lighting switch terminal 6
- to RH headlamp terminal HI, and
- from lighting switch terminal 9
- to daytime light control unit terminal 5, and
- to combination meter terminal 2 (with tachometer), 12 (without tachometer) for the high beam indicator
- through daytime light control unit terminal 6
- to LH headlamp terminal HI.

Ground is supplied in the same manner as low beam operation.

For the combination meter, ground is supplied

- to terminal 3 (with tachometer), 14 (without tachometer)
- through body grounds M28 and M54.

With power and ground supplied, the high beam headlamps and high beam indicator illuminate.

DAYTIME LIGHT OPERATION

With the engine running and the lighting switch in the "OFF" or parking lamp (1ST) position and parking brake released, power is supplied

- to daytime light control unit terminal 3
- through daytime light control unit terminal 6
- to LH headlamp terminal HI
- through LH headlamp terminal E
- to daytime light control unit terminal 7
- through daytime light control unit terminal 8
- to RH headlamp terminal HI.

Ground is supplied

- to RH headlamp terminal E
- through body grounds E7 and E37.

Because the high beam headlamps are wired in series during daytime light operation, they operate at half illumination.

A

B

C

D

E

F

G

H

I

J

LT

L

M

INTERIOR, MAP, VANITY AND TRUNK ROOM LAMPS

4. CHECK DOOR UNLOCK SENSOR LH INPUT SIGNAL

With CONSULT-II

Perform "LOCK SIG DR" in "DATA MONITOR" mode with CONSULT-II.

DATA MONITOR	
MONITOR	
LOCK SIG DR	OFF

When front LH door is locked:
LOCK SIG DR OFF

When front LH door is unlocked:
LOCK SIG DR ON

SEL344W

Without CONSULT-II

Check voltage between smart entrance control unit harness connector terminal 36 and ground.

Smart entrance control unit connector (M39)

CONNECT

	Terminals		Condition	Voltage [V]
	(+)	(-)		
Front LH door	36	Ground	Locked	Approx. 5
			Unlocked	0

LEL452

OK or NG

- OK >> GO TO 6.
- NG >> GO TO 5.

5. CHECK DOOR UNLOCK SENSOR LH

1. Disconnect door unlock sensor LH harness connector.
2. Check continuity between door unlock sensor LH terminals.

Front door lock actuator LH connector (D7)

DISCONNECT

Continuity:
Condition: Locked
 No
Condition: Unlocked
 Yes

WEL497

OK or NG

- OK >> Check the following.
 - Door unlock sensor LH ground circuit
 - Harness for open or short between smart entrance control unit and door unlock sensor LH
- NG >> Replace door unlock sensor LH.

PERIODIC MAINTENANCE

MAINTENANCE OPERATION		MAINTENANCE INTERVAL								Reference Section - Page or - Content Title	
Perform at number of miles, kilometers or months, whichever comes first.	Miles x 1,000 (km x 1,000)	33.75 (54)	37.5 (60)	41.25 (66)	45 (72)	48.75 (78)	52.5 (84)	56.25 (90)	60 (96)	QG18DE	QR25DE
	Months	27	30	33	36	39	42	45	48		
Engine coolant	NOTE (4)								R*	MA-16, "Changing Engine Coolant"	MA-23, "Changing Engine Coolant"
Engine oil		R	R	R	R	R	R	R	R	MA-20, "Changing Engine Oil"	MA-26, "Changing Engine Oil"
Engine oil filter (Use part No. 15208-65F01, 15208-9E000 or equiv.)		R	R	R	R	R	R	R	R	MA-20, "Changing Oil Filter"	—
Engine oil filter (Use part No. 15208-9E000 or equiv.)		R	R	R	R	R	R	R	R	—	MA-27, "Changing Oil Filter"
Spark plugs (Double PLATINUM-TIPPED type)		Replace every 105,000 miles (169,000 km)								MA-21, "Changing Spark Plugs (Double Platinum - Tipped Type)"	MA-28, "Changing Spark Plugs (Double Platinum - Tipped Type)"
Intake and exhaust valve clearance	NOTE (5)*									EM-38, "Valve Clearance"	—

NOTE:

- (1) After 60,000 miles (96,000 km) or 48 months, inspect every 15,000 miles (24,000 km) or 12 months. Replace the drive belt if found damaged or if the auto belt tensioner reading (for QR25DE engine) reaches the maximum limit.
- (2) If operating mainly in dusty conditions, more frequent maintenance may be required.
- (3) Maintenance-free item.
- (4) After 60,000 miles (96,000 km) or 48 months, replace every 30,000 miles (48,000 km) or 24 months.
- (5) If valve noise increases, inspect valve clearance.

Maintenance items and intervals with "*" are recommended by NISSAN for reliable vehicle operation. The owner need not perform such maintenance in order to maintain the emission warranty or manufacturer recall liability. Other maintenance items and intervals are required.

CHASSIS AND BODY MAINTENANCE

Abbreviations: R = Replace. I = Inspect. Correct or replace if necessary. L = Lubricate.

MAINTENANCE OPERATION		MAINTENANCE INTERVAL								Reference Section - Page or - Content Title
Perform at number of miles, kilometers or months, whichever comes first.	Miles x 1,000 (km x 1,000)	3.75 (6)	7.5 (12)	11.25 (18)	15 (24)	18.75 (30)	22.5 (36)	26.25 (42)	30 (48)	
	Months	3	6	9	12	15	18	21	24	
Brake lines & cables					I				I	MA-32
Brake pads, rotors, drums & linings (QG18DE)			I		I		I		I	MA-33 and MA-34
Brake pads & rotors (QR25DE)			I		I		I		I	MA-33

PREPARATION

[RS5F70A]



PFP:00002

ECS005TE

PREPARATION

Special Service Tools

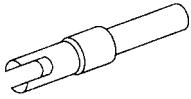
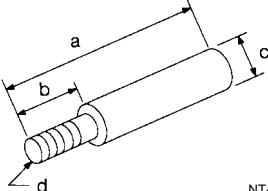
The actual shapes of the Kent-Moore tools may differ from those of the special service tools illustrated here.

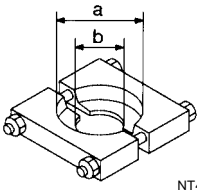
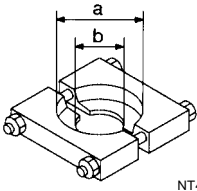
Tool number (Kent-Moore No.) Tool name	Description
KV38107700 (J39027) Preload adapter <div style="text-align: center;">  <p>NT087</p> </div>	Measuring turning torque of final drive assembly Measuring total turning torque Measuring clearance between side gear and differential case with washer Selecting differential side bearing adjusting shim [Use with KV38106000 (J34291-B).]
KV38106000 (J34291-B) Height gauge adapter (differential side bearing) <div style="text-align: center;">  <p>NT418</p> </div>	Selecting differential side bearing adjusting shim [Use with KV38107700 (J39027).] a: 140 mm (5.51 in) b: 40 mm (1.57 in) c: 16 mm (0.63 in) dia. d: M8 × 1.25P
KV32101000 (J25689-A) Pin punch <div style="text-align: center;">  <p>NT410</p> </div>	Removing and installing retaining pin Removing and installing lock pin Removing selector shaft Removing welch plug a: 4 mm (0.16 in) dia.
KV31100300 (J25689-A) Pin punch <div style="text-align: center;">  <p>NT410</p> </div>	Removing and installing retaining pin a: 4.5 mm (0.177 in) dia.
ST30031000 (J22912-01) Puller <div style="text-align: center;">  <p>NT411</p> </div>	Removing 3rd, 5th input gear Removing 3rd & 4th and 5th & Rev synchronizer hub Removing mainshaft rear bearing Removing 2nd gear, 5th gear bush Removing 1st & 2nd synchronizer hub, 1st and 4th main gear Removing and installing differential side bearing a: 90 mm (3.54 in) dia. b: 50 mm (1.97 in) dia.
ST30021000 (J22912-01) Puller <div style="text-align: center;">  <p>NT411</p> </div>	Removing input shaft front and rear bearing Installing input shaft front and rear bearing Installing 5th input gear, 3rd main gear and 4th main gear Installing 1st & 2nd, 3rd & 4th and 5th & Rev synchronizer hub Installing 2nd gear bush, 5th gear bush, Rev gear bush Installing mainshaft rear bearing a: 110 mm (4.33 in) dia. b: 68 mm (2.68 in) dia.

INPUT SHAFT AND GEARS

[RS5F70A]

6. Remove 5th input gear from input shaft using Tool.
7. Remove 5th gear front C-ring.

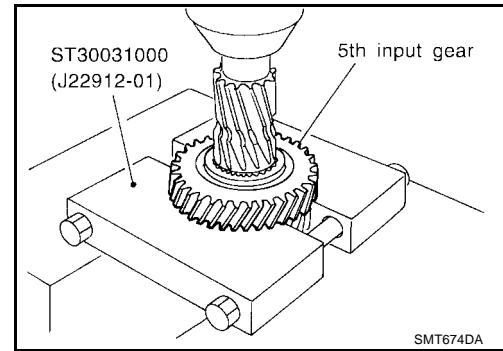

8. Remove 4th input gear, baulk ring, 4th gear needle bearing, and 4th gear C-ring from input shaft.
9. Press out both 3rd & 4th synchronizer hub assembly and 3rd input gear from input shaft using Tool.
10. Remove 3rd gear needle bearing.

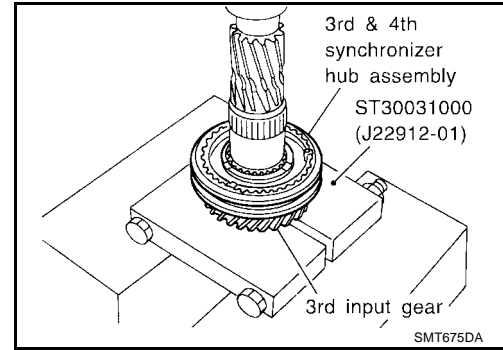

11. Press out input shaft front bearing from input shaft using Tool.

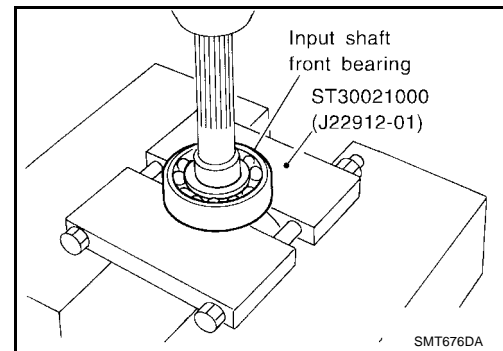

ECS005TR

Inspection GEAR AND SHAFT

- Check shaft for cracks, wear or bending.
- Check gears for excessive wear, chips or cracks.

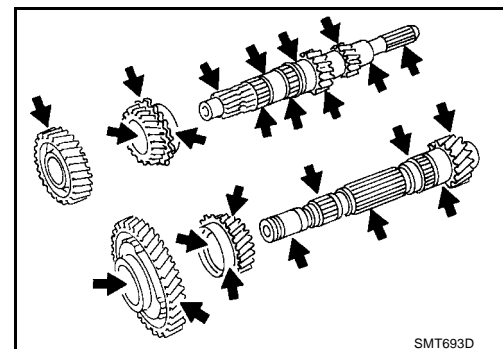

A
B
MT
D
E
F
G
H
I
J
K
L
M

SIDE OIL SEAL

Removal and Installation

REMOVAL

1. Remove the drive shaft from the transaxle body. Refer to [FAX-14, "Removal"](#) .
2. Remove oil seal with a slotted screwdriver.

CAUTION:

Be careful not to damage the case surface when removing the oil seal.

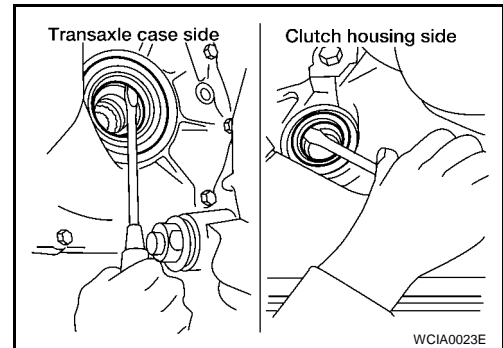

INSTALLATION

Installation is in the reverse order of removal.

- Using Tool (drift), drive the new oil seal straight until it protrudes from the case end equal to dimension "A" as shown.

Dimension "A" : Within 0.5 mm (0.02 in) or flush with the case.

Tool (drift) : ST30720000 (J25405)

CAUTION:

- Before installing oil seal, apply multi-purpose grease to oil seal lips.
- Oil seal is not reusable.
- Check oil level after installation. Refer to [MT-73, "Checking"](#) .

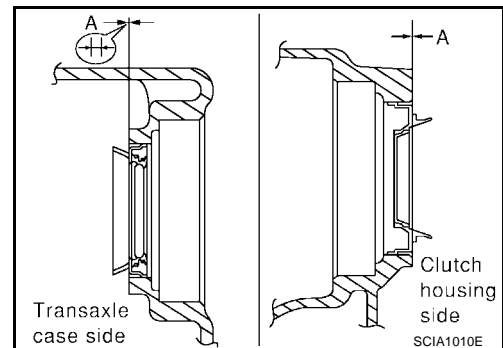

9. Remove the 3rd main gear, 2nd main gear, 2nd gear needle bearing, 2nd bushing, 1st-2nd synchronizer assembly, 1st main gear, reverse main gear, 1st gear needle bearing, and 1st bushing simultaneously using Tool as shown.

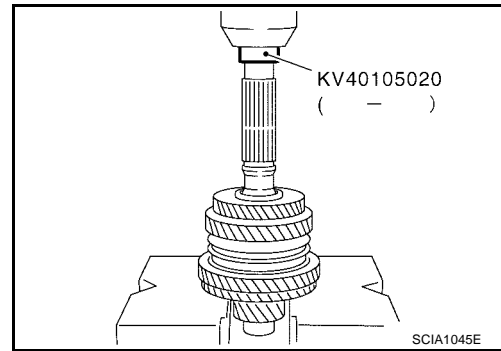

INSPECTION AFTER DISASSEMBLY

Mainshaft and Gears

Check the items listed as shown. If necessary, replace them with new ones.

- Damage, peeling, dent, uneven wear, bending, and other non-standard conditions of the mainshaft.
- Excessive wear, damage, peeling, and other non-standard conditions of the mainshaft gears.

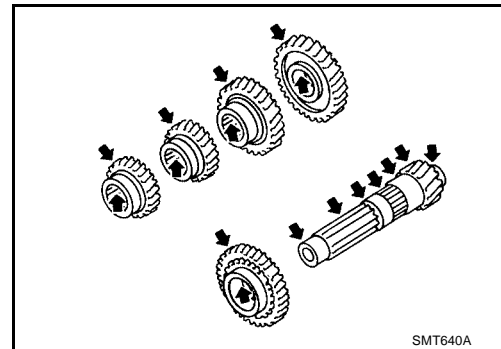

Synchronizer

Check the items listed as shown. If necessary, replace them with new ones.

- Damage, unusual wear on contact surfaces of coupling sleeve, synchronizer hub, and shifting insert.
- Coupling sleeve and synchronizer hub must move smoothly as shown.

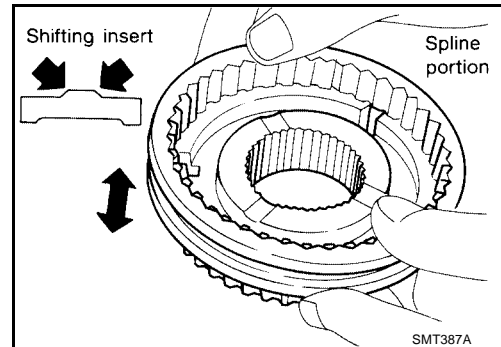

- If any cracks, damage, or excessive wear is found on the cam face of baulk ring or working face of the insert, replace it.

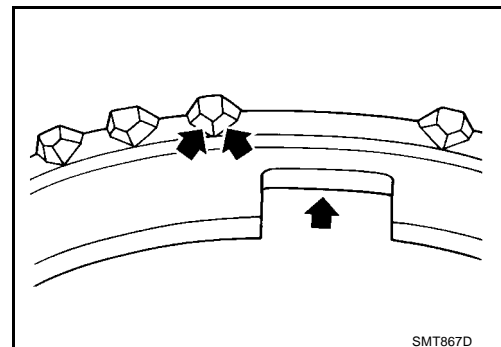

A
B
MT
D
E
F
G
H
I
J
K
L
M

LUBRICANT

Lubricant adjusting procedure for compressor replacement

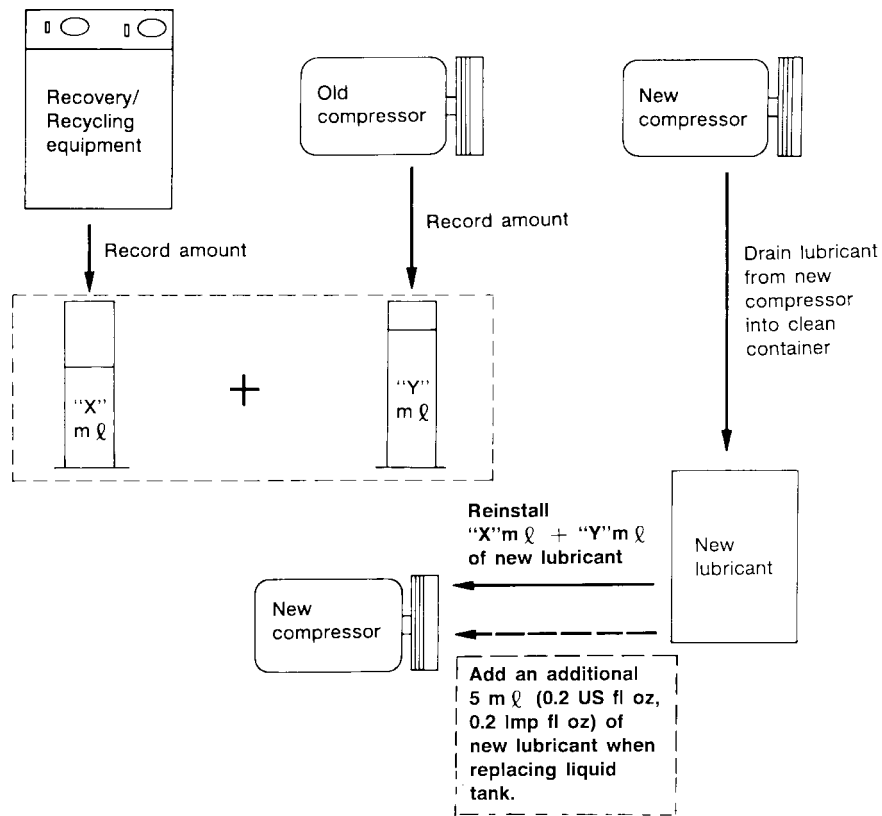

RHA065DD

INSUFFICIENT COOLING

PF0:0000

EJS001B7

INSUFFICIENT COOLING

Trouble Diagnosis Procedure for Insufficient Cooling

SYMPTOM:

- Insufficient cooling

INSPECTION FLOW

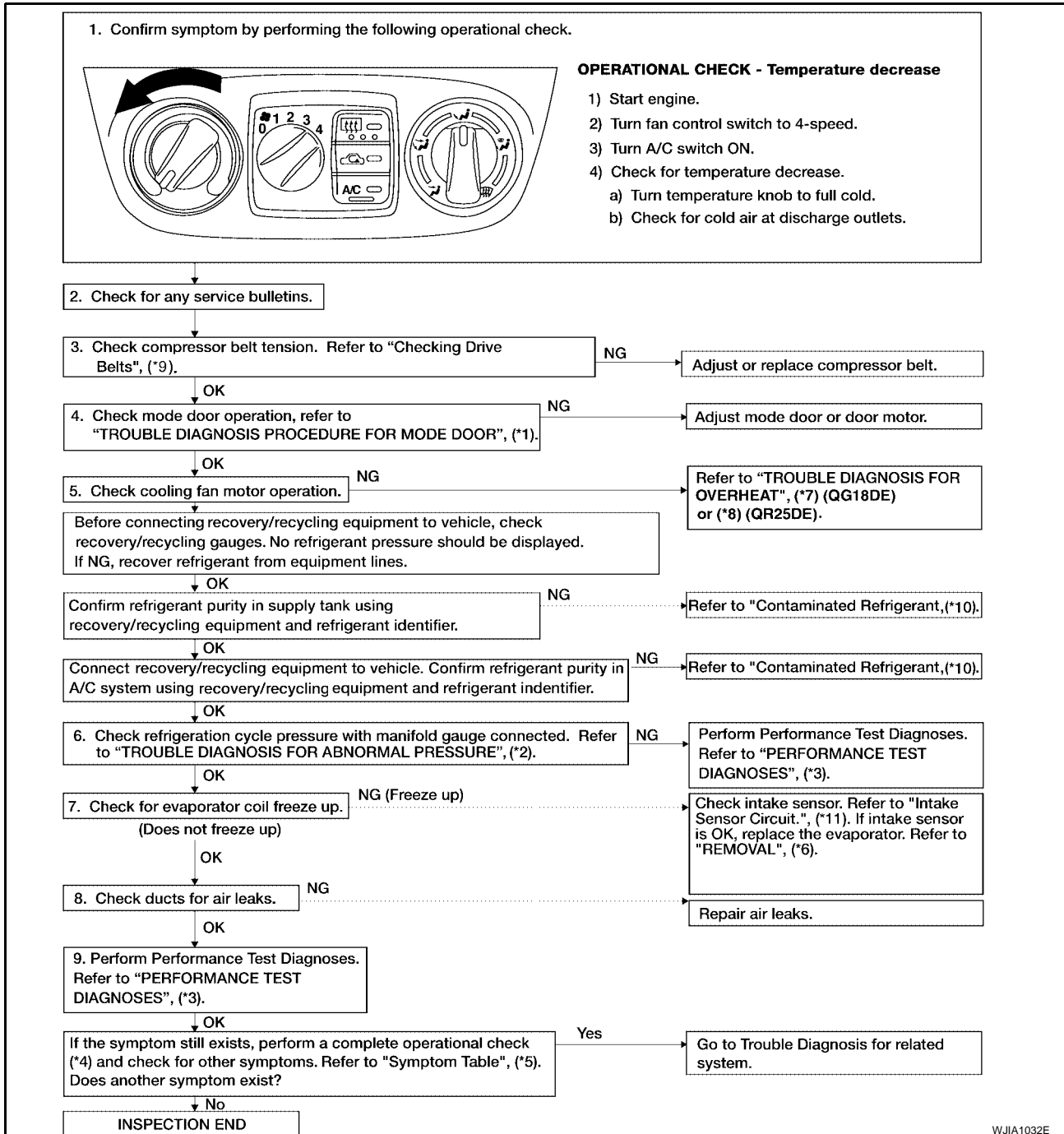

*1 [MTC-38](#)

*4 [MTC-31](#)

*7 [EC-455](#)

*10 [MTC-3](#)

*2 [MTC-57](#)

*5 [MTC-30](#)

*8 [EC-1161](#)

*11 [MTC-62](#)

*3 [MTC-54](#)

*6 [MTC-76](#)

*9 [MA-17](#) (QG18DE) or [MA-24](#) (QR25DE)

SERVICE DATA AND SPECIFICATIONS (SDS)

HARNESS

QG18DE (SULEV)

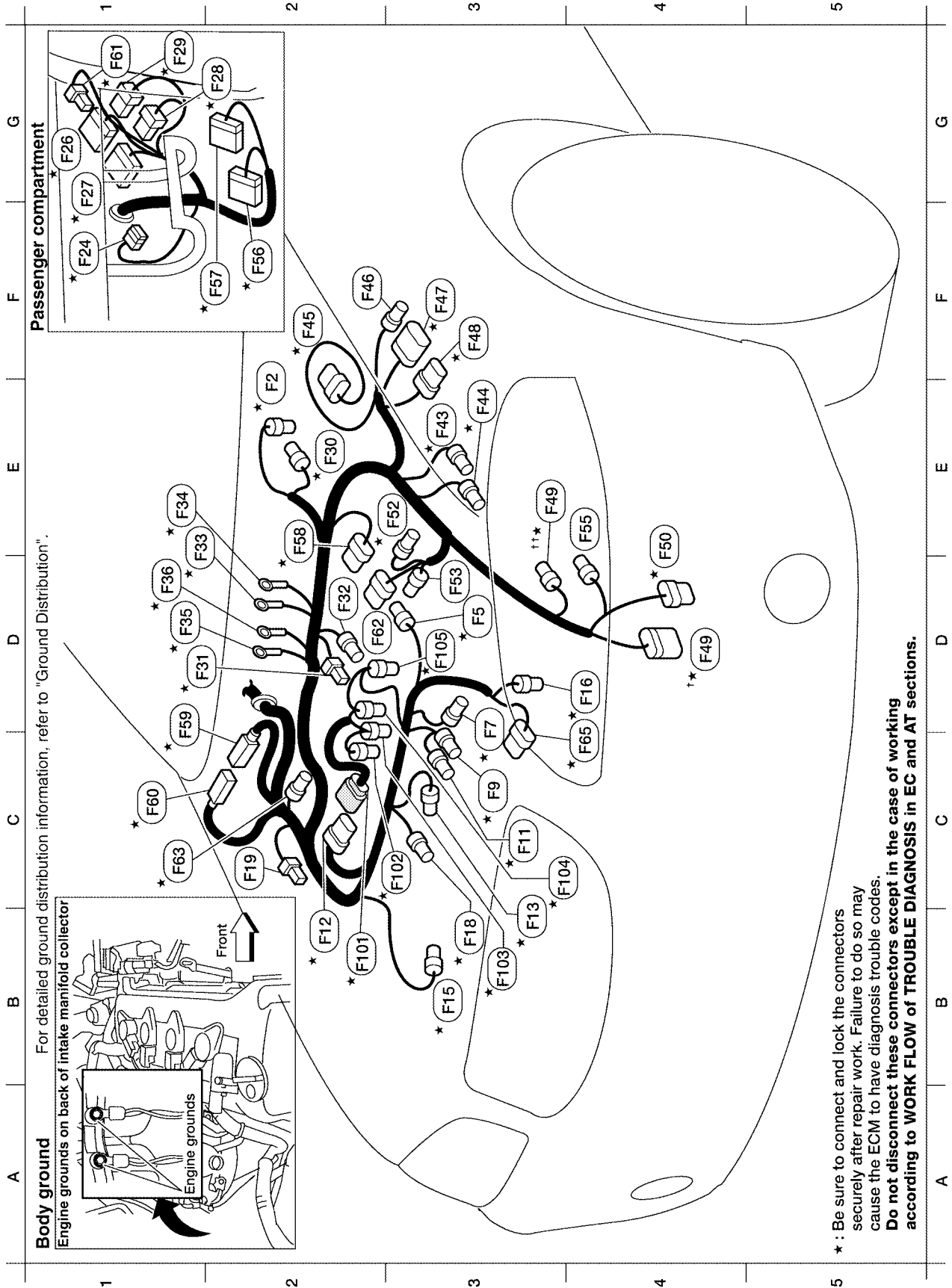

WKIA0971E

STEERING WHEEL AND STEERING COLUMN

STEERING COLUMN

Removal

CAUTION:

- The rotation of the spiral cable (SRS "Air Bag" component part) is limited. If the steering gear must be removed, set the front wheels in the straight-ahead direction. Do not rotate the steering column while the steering gear is removed.
 - Remove the steering wheel before removing the steering lower joint to avoid damaging the SRS spiral cable.
1. Disconnect the battery negative terminal.
 2. Remove the steering wheel. Refer to [PS-11, "STEERING WHEEL"](#).
 3. Removal spiral cable. Refer to [SRS-43, "Removal and Installation"](#).
 4. Disconnect data link connector.
 5. Remove lower instrument panel and lower reinforcement panel. Refer to [IP-10, "Removal and Installation"](#).
 6. Remove the column covers.
 7. Disconnect electrical connectors.
 8. Remove three screws securing combination switch and remove combination switch.
 9. Remove key interlock cable (A/T models).
 10. Remove the hole cover, then remove bolt from lower joint.
 11. Remove the steering column lower cover.
 12. Remove four nuts securing steering column and remove steering column.

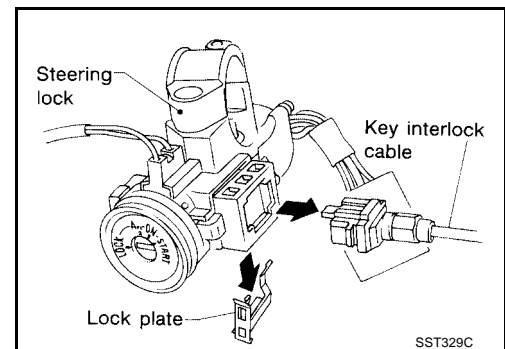

Installation

1. Installation is the reverse order of removal.
 - When installing steering column, finger tighten all lower bracket and clamp retaining bolts; then tighten them securely. Do not apply undue stress to steering column.
 - When attaching coupling joint, be sure tightening bolt faces cutout portion.

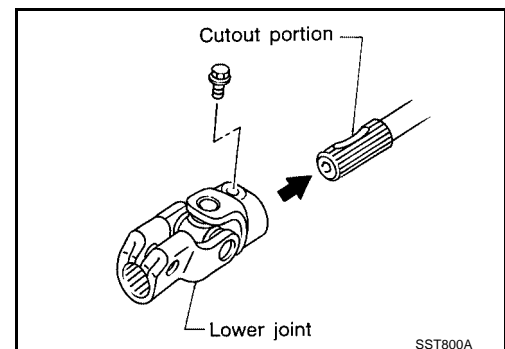

- Align slit of lower joint with projection on dust cover. Insert joint until surface A contacts surface B.

CAUTION:

After installation, turn steering wheel to make sure it moves smoothly. Ensure the number of turns are the same from the straight forward position to left and right locks. Be sure that the steering wheel is in a neutral position when driving straight ahead.

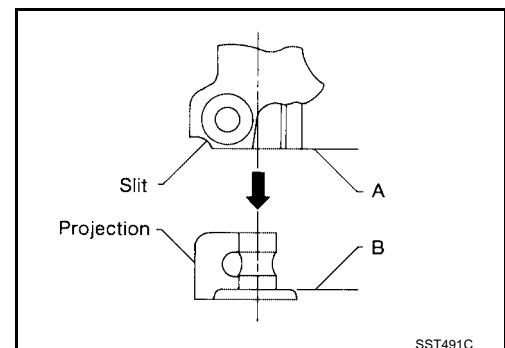

SQUEAK AND RATTLE TROUBLE DIAGNOSES

SQUEAK & RATTLE DIAGNOSTIC WORKSHEET- page 2

Briefly describe the location where the noise occurs:

II. WHEN DOES IT OCCUR? (check the boxes that apply)

- | | |
|--|---|
| <input type="checkbox"/> anytime | <input type="checkbox"/> after sitting out in the sun |
| <input type="checkbox"/> 1 st time in the morning | <input type="checkbox"/> when it is raining or wet |
| <input type="checkbox"/> only when it is cold outside | <input type="checkbox"/> dry or dusty conditions |
| <input type="checkbox"/> only when it is hot outside | <input type="checkbox"/> other: _____ |

III. WHEN DRIVING:

- through driveways
- over rough roads
- over speed bumps
- only at about ____ mph
- on acceleration
- coming to a stop
- on turns : left, right or either (circle)
- with passengers or cargo
- other: _____
- after driving ____ miles or ____ minutes

IV. WHAT TYPE OF NOISE?

- squeak (like tennis shoes on a clean floor)
- creak (like walking on an old wooden floor)
- rattle (like shaking a baby rattle)
- knock (like a knock on a door)
- tick (like a clock second hand)
- thump (heavy, muffled knock noise)
- buzz (like a bumble bee)

TO BE COMPLETED BY DEALERSHIP PERSONNEL

Test Drive Notes:

	<u>YES</u>	<u>NO</u>	<u>Initials of person performing</u>
Vehicle test driven with customer	<input type="checkbox"/>	<input type="checkbox"/>	_____
- Noise verified on test drive	<input type="checkbox"/>	<input type="checkbox"/>	_____
- Noise source located and repaired	<input type="checkbox"/>	<input type="checkbox"/>	_____
- Follow up test drive performed to confirm repair	<input type="checkbox"/>	<input type="checkbox"/>	_____

VIN: _____ Customer Name: _____

W.O. #: _____ Date: _____

SBT844

This form must be attached to Work Order

PRECAUTIONS

PRECAUTIONS

PFP:00001

Precautions for Supplemental Restraint System (SRS) “AIR BAG” and “SEAT BELT PRE-TENSIONER”

EKS006EZ

The Supplemental Restraint System such as “AIR BAG” and “SEAT BELT PRE-TENSIONER”, used along with a front seat belt, helps to reduce the risk or severity of injury to the driver and front passenger for certain types of collision. Information necessary to service the system safely is included in the SRS and SB section of this Service Manual.

WARNING:

- To avoid rendering the SRS inoperative, which could increase the risk of personal injury or death in the event of a collision which would result in air bag inflation, all maintenance must be performed by an authorized NISSAN/INFINITI dealer.
- Improper maintenance, including incorrect removal and installation of the SRS, can lead to personal injury caused by unintentional activation of the system. For removal of Spiral Cable and Air Bag Module, see the SRS section.
- Do not use electrical test equipment on any circuit related to the SRS unless instructed to in this Service Manual. SRS wiring harnesses can be identified by yellow and/or orange harnesses or harness connectors.

Wiring Diagrams and Trouble Diagnosis

EKS0037M

When you read wiring diagrams, refer to the following:

- [GI-15, "How to Read Wiring Diagrams"](#)
- [PG-3, "POWER SUPPLY ROUTING"](#) for power distribution circuit.

When you perform trouble diagnosis, refer to the following:

- [GI-11, "HOW TO FOLLOW TEST GROUPS IN TROUBLE DIAGNOSES"](#).
- [GI-27, "How to Perform Efficient Diagnosis for an Electrical Incident"](#)

FRONT SEAT

FRONT SEAT

PFP:87000

Removal and Installation

EIS0017D

CAUTION:

- On vehicles equipped with side air bags, before removing the front seat, turn the ignition switch off, disconnect the negative and positive battery cables and wait a minimum of 3 minutes.
- When checking the power seat circuitry for continuity using a circuit tester, do not confuse the seat connector with the side air bag connector. Doing so could cause the side air bag to deploy.
- Do not drop, tilt, or bump the side air bag module installed in the seat. Always handle it with care.
- Disconnect the side air bag harness connector, if equipped, and the power seat switch harness connector from under the seat before removing the seat.
- After front side air bag module inflates, front seatback assembly must be replaced.

NOTE:

Only complete seatback assemblies can be replaced on vehicles equipped with side air bags.

A
B
C
D
E
F
G
H
J
K
L
M

SE

CLICK HERE TO **DOWNLOAD** THE COMPLETE MANUAL

- Thank you very much for reading the preview of the manual.
- You can download the complete manual from: www.heydownloads.com by clicking the link below



- Please note: If there is no response to CLICKING the link, please download this PDF first and then click on it.

CLICK HERE TO **DOWNLOAD** THE COMPLETE MANUAL