

# **NISSAN TRUCK/ PATHFINDER**

**MODEL D21 SERIES**

## **QUICK REFERENCE INDEX**

<b>GENERAL INFORMATION</b> _____	<b>GI</b>
<b>MAINTENANCE</b> _____	<b>MA</b>
<b>ENGINE MECHANICAL</b> _____	<b>EM</b>
<b>ENGINE LUBRICATION &amp; COOLING SYSTEMS</b> —	<b>LC</b>
<b>ENGINE FUEL &amp; EMISSION CONTROL SYSTEM</b> —	<b>EF &amp; EC</b>
<b>ENGINE CONTROL, FUEL &amp; EXHAUST SYSTEMS</b> -	<b>FE</b>
<b>CLUTCH</b> _____	<b>CL</b>
<b>MANUAL TRANSMISSION</b> _____	<b>MT</b>
<b>AUTOMATIC TRANSMISSION</b> _____	<b>AT</b>
<b>TRANSFER</b> _____	<b>TF</b>
<b>PROPELLER SHAFT &amp; DIFFERENTIAL CARRIER</b> —	<b>PD</b>
<b>FRONT AXLE &amp; FRONT SUSPENSION</b> _____	<b>FA</b>
<b>REAR AXLE &amp; REAR SUSPENSION</b> _____	<b>RA</b>
<b>BRAKE SYSTEM</b> _____	<b>BR</b>
<b>STEERING SYSTEM</b> _____	<b>ST</b>
<b>BODY</b> _____	<b>BF</b>
<b>HEATER &amp; AIR CONDITIONER</b> _____	<b>HA</b>
<b>ELECTRICAL SYSTEM</b> _____	<b>EL</b>

CLICK HERE TO **DOWNLOAD** THE COMPLETE MANUAL

- Thank you very much for reading the preview of the manual.
- You can download the complete manual from: [www.heydownloads.com](http://www.heydownloads.com) by clicking the link below



- Please note: If there is no response to CLICKING the link, please download this PDF first and then click on it.

CLICK HERE TO **DOWNLOAD** THE COMPLETE MANUAL

# IDENTIFICATION INFORMATION

## Model Variation (Cont'd)

### 4-WHEEL DRIVE TRUCK

Destination	Engine		Z24i		VG30i					
	Transmission		FS5W71C		FS5R30A		RE4R01A			
	Transfer		TX 10		TX 10		TX 10			
	Differential carrier		Front R180A	Rear C200	Front R200A	Rear H233B	Front R200A	Rear H233B		
Non-California, U.S.A.	Regular Cab	E	Standard wheelbase		NLYD21FEU		HLYD21FEU		HLYD21KEU	
	King Cab	E	Long wheelbase		KNLMD21FEU		-		-	
SE		-			KHLMD21PFEU		KHLMD21PKEU			
California, U.S.A.	Regular Cab	E	Standard wheelbase		NLYD21FEV		HLYD21FEV		HLYD21KEV	
	King Cab	E	Long wheelbase		KNLMD21FEV		-		-	
SE		-			KHLMD21PFEV		KHLMD21PKEV			
Canada	Regular Cab	E	Standard wheelbase		NLYD21FEN		-		-	
		XE			NLYD21JFEN		-		-	
	King Cab	XE	Long wheelbase		KNLMD21JFEN		-		-	
		SE			-		KHLMD21PFEN		KHLMD21PKEN	

### 4-WHEEL DRIVE PATHFINDER

Destination	Engine		Z24i		VG30i			
	Transmission		FS5W71C		FS5R30A		RE4R01A	
	Transfer		TX 10		TX 10		TX 10	
	Differential carrier		Front R180A	Rear C200	Front R200A	Rear H233B	Front R200A	Rear H233B
Non-California, U.S.A.	Wagon	E	WNLYD21FEU		-		-	
		XE	-		WHLYD21JFEU		WHLYD21JKEU	
		SE	-		WHLYD21PFEU		WHLYD21PKEU	
California, U.S.A.	Wagon	XE	-		WHLYD21JFEV		WHLYD21JKEV	
		SE	-		WHLYD21PFEV		WHLYD21PKEV	
Canada	Van	E	VNLYD21FEN		-		-	
		XE	-		VHLYD21JFEN		VHLYD21JKEN	
		SE	-		VHLYD21PFEN		VHLYD21PKEN	

# MAINTENANCE

## SECTION **MA**

**MA**

### CONTENTS

PREPARATION .....	MA- 2
PERIODIC MAINTENANCE .....	MA- 3
GENERAL MAINTENANCE .....	MA- 5
LUBRICATION CHART .....	MA- 8
ENGINE MAINTENANCE .....	MA- 9
CHASSIS AND BODY MAINTENANCE .....	MA-26
SERVICE DATA AND SPECIFICATIONS (S.D.S.) .....	MA-52

**Oil Filter Replacement (Cont'd)**

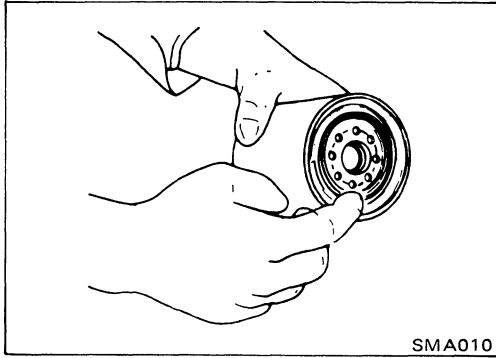

2. Before installing new oil filter, wipe clean oil filter mounting surface on cylinder block, and smear a little engine oil on rubber seal of oil filter.

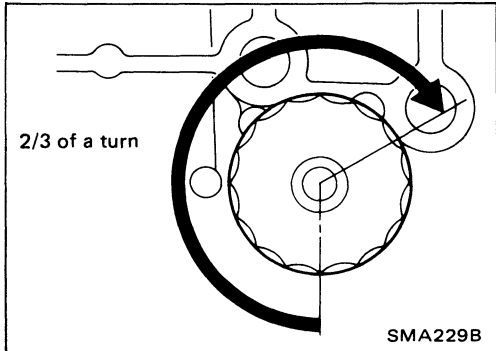

3. Screw oil filter on until a slight resistance is felt, then tighten an additional more than 2/3 turn.

4. Add engine oil.

Refer to Changing Engine Oil.

**Spark Plug Replacement**

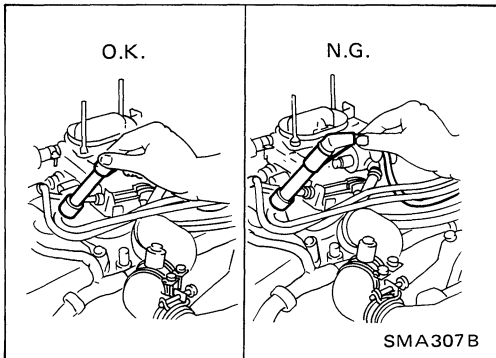

1. Remove air cleaner.
2. Disconnect ignition wires from spark plugs by pulling on boots. Do not pull on wires.

**CAUTION:**

Before removing spark plug, be sure there is no foreign substance in the hollow area around spark plug.

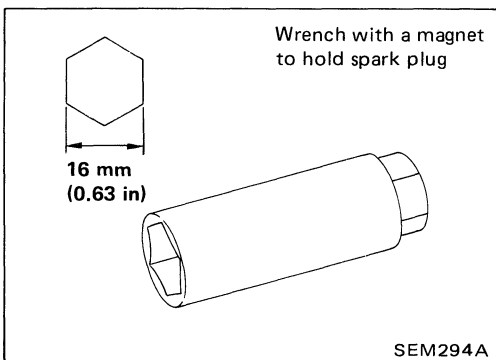

3. Remove spark plugs with suitable spark plug wrench.

**Spark plug:**

Standard type	BCPR5ES-11
Hot type	BCPR4ES-11
Cold type	BCPR6ES-11

# CHASSIS AND BODY MAINTENANCE

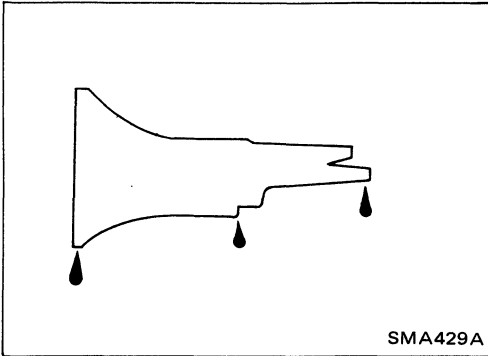

## Checking M/T Oil

1. Check manual transmission for oil leakage.

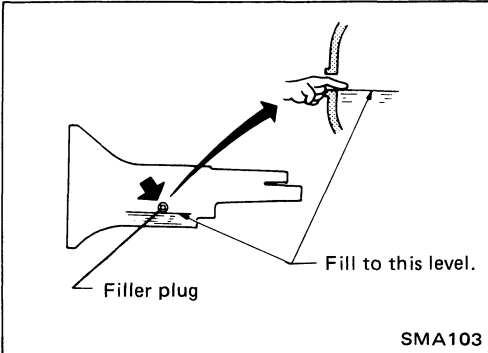

2. If leakage is found, check oil level.

 : Filler plug  
25 - 34 N·m  
(2.5 - 3.5 kg-m, 18 - 25 ft-lb)

### CAUTION:

Never start engine while checking oil level.

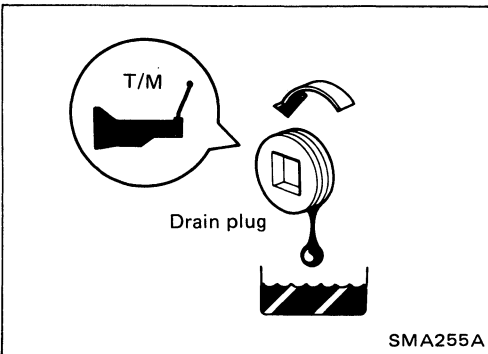

## Changing M/T Oil

Oil capacity:

F4W71C 1.7 liters (3-5/8 US pt, 3 Imp pt)

FS5W71C

2WD 2.0 liters (4-1/4 US pt, 3-1/2 Imp pt)

4WD 4.0 liters (8-1/2 US pt, 7 Imp pt)

FS5R30A

2WD 2.4 liters (5-1/8 US pt, 4-1/4 Imp pt)

4WD 3.6 liters (7-5/8 US pt, 6-3/8 Imp pt)

Drain plug:

 : 25 - 34 N·m (2.5 - 3.5 kg-m, 18 - 25 ft-lb)

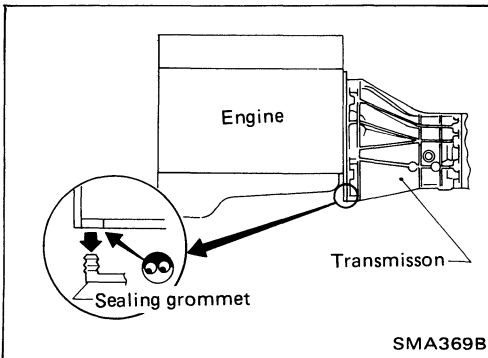

## Checking Water Entry – For 4WD model

Check water entry in the clutch housing by removing the sealing grommet, whenever driving in deep water or mud.

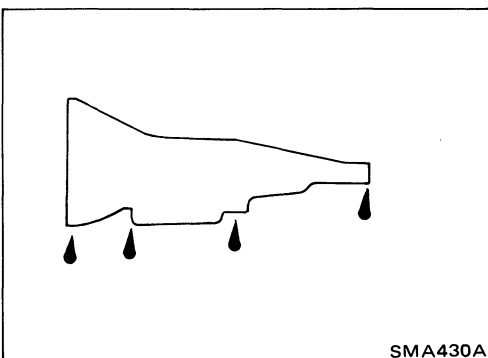

## Checking A/T Fluid

1. Check automatic transmission for fluid leakage.

## CHASSIS AND BODY MAINTENANCE

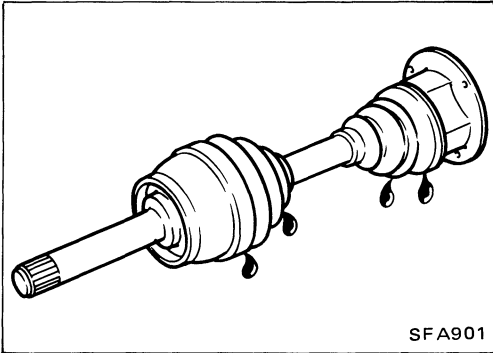

### Checking Drive Shaft

Check boot and drive shaft for cracks, wear, damage or grease leakage.

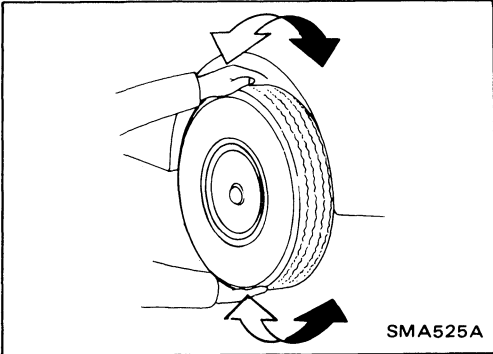

### Checking Rear Axle and Rear Suspension Parts

- Check axle and suspension parts for looseness, wear or damage.

(1) Shake each rear wheel.

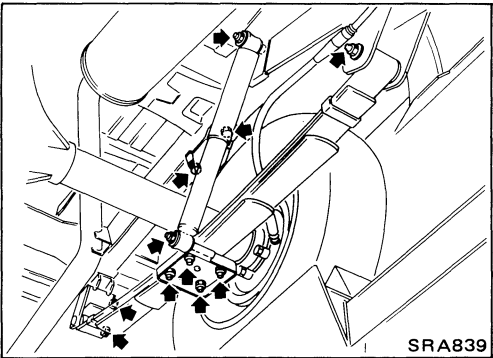

(2) Retighten all nuts and bolts to the specified torque.

**Tightening torque: Refer to section RA.**

(3) Check axle and suspension parts for wear, cracks or other damage.

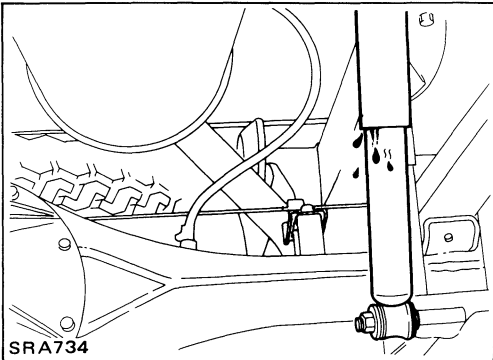

- Check shock absorber for oil leakage or damage.

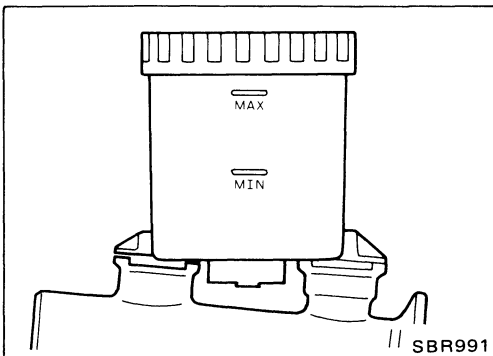

### Checking Brake Fluid Level and Leaks

If fluid level is extremely low, check brake system for leaks.

# SERVICE DATA AND SPECIFICATIONS (S.D.S.)

## Engine Maintenance (Cont'd)

### INSPECTION AND ADJUSTMENT

#### Drive belt deflection

Unit: mm (in)

	Used belt deflection		Set deflection of new belt
	Limit	Adjusted deflection	
Alternator	16 (0.63)	9 - 11 (0.35 - 0.43)	7 - 9 (0.28 - 0.35)
Air conditioner compressor	13 (0.51)	8 - 10 (0.31 - 0.39)	6 - 8 (0.24 - 0.31)
Power steering oil pump	16 (0.63)	10 - 12 (0.39 - 0.47)	8 - 10 (0.31 - 0.39)
Applied pushing force	98 N (10 kg, 22 lb)		

Inspect drive belt deflections when engine is cold.  
If engine is hot, check deflections in 30 minutes or more.

#### Oil capacity (Approximate refill capacity)

Unit: ℓ (US qt, Imp qt)

	2WD	4WD
With oil filter change	3.8 (4, 3-3/8)	4.3 (4-1/2, 3-3/4)
Without oil filter change	3.3 (3-1/2, 2-7/8)	3.8 (4, 3-3/8)

#### Coolant capacity

Unit: ℓ (US qt, Imp qt)

Refill capacity (without reservoir tank)	8.2 (8-5/8, 7-1/4)
Reservoir tank	0.6 (5/8, 1/2)

#### Spark plug

	Intake and Exhaust sides
Standard type	BPR5ES
Hot type	BPR4ES
Cold type	BPR6ES
Plug gap	0.8 - 0.9 mm (0.031 - 0.035 in)

#### Valve clearance

Unit: mm (in)

Intake	0.30 (0.012)
Exhaust	0.30 (0.012)

#### Idle speed

Idle speed	rpm	M/T 800±50 A/T 650±50 (in "D" position)
------------	-----	--

#### TIGHTENING TORQUE

Item	N·m	kg·m	ft·lb
Alternator adjuster lock bolt	8 - 11	0.8 - 1.1	5.8 - 8.0
Power steering pump adjusting bolt	16 - 22	1.6 - 2.2	12 - 16
Idler adjuster lock nut	16 - 22	1.6 - 2.2	12 - 16
Oil pan drain plug	29 - 39	3.0 - 4.0	22 - 29
Spark plug	20 - 29	2.0 - 3.0	14 - 22
Intake and exhaust valve pivot lock nut	16 - 22	1.6 - 2.2	12 - 16

# OIL PAN REMOVAL AND INSTALLATION

## Removal

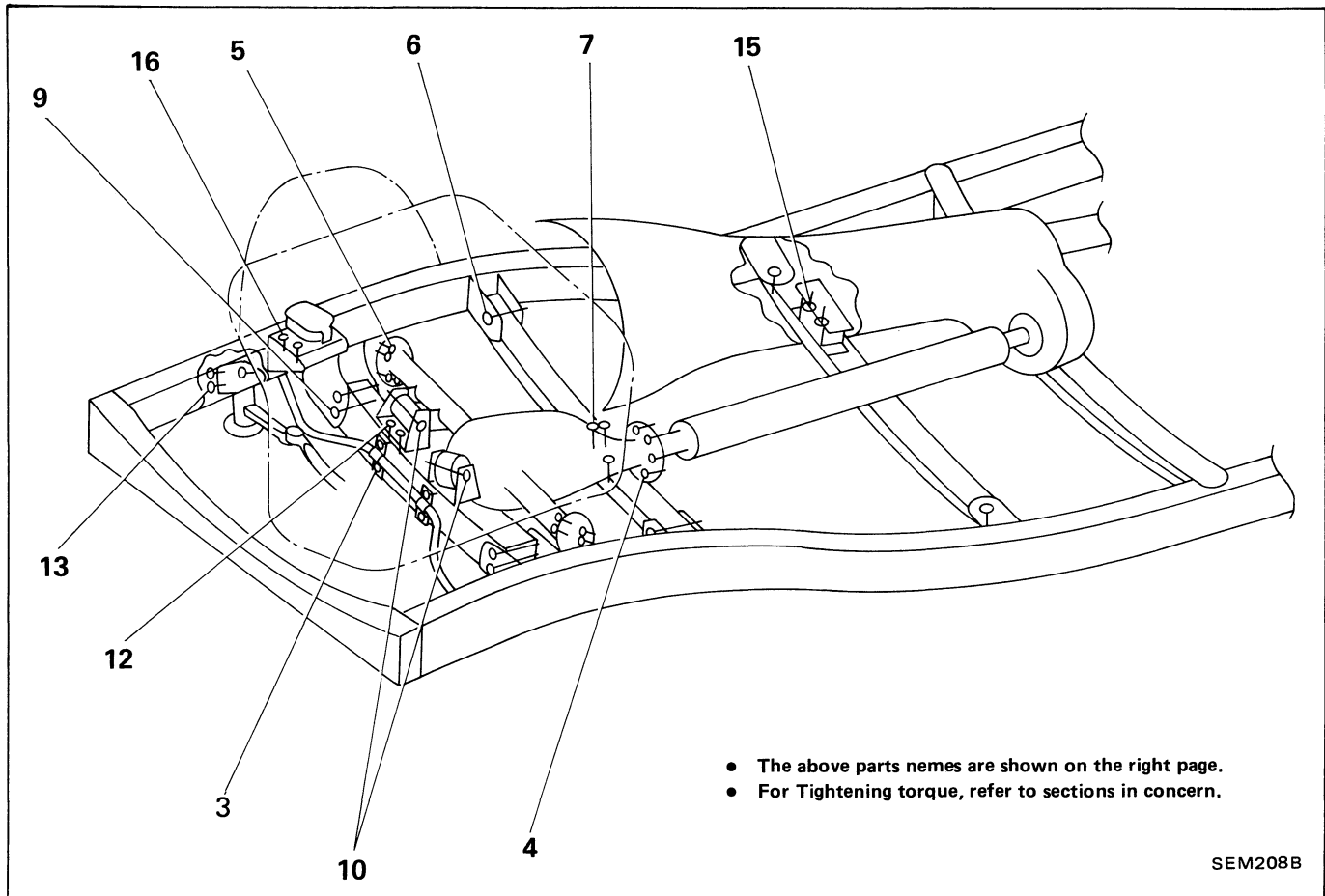

### WARNING:

- a. Place vehicle on a flat and solid surface.
- b. Place chocks at front and rear of rear wheels.
- c. You should not remove oil pan until exhaust system and cooling system have completely cooled off. Otherwise, you may burn yourself and/or fire may break out in the fuel line.
- d. When remove front and/or rear engine mounting bolts or nuts, lift up slightly engine for safety work.

### CAUTION:

- a. In lifting engine, be careful not to hit against adjacent parts, especially against accelerator wire casing end, brake tube and brake master cylinder.
- b. For tightening torque, refer to sections AT, MT and PD.

## Removal

1. Remove radiator shroud, fan and pulleys.  
Refer to ENGINE COOLING SYSTEM — Radiator (section LC).
2. Drain coolant from radiator and remove water pump hose.  
**Be careful not to spill coolant on drive belts.**
3. Remove all spark plugs.
4. Remove the following belts.
  - Power steering drive belt
  - Compressor drive belt
  - Alternator drive belt
5. Remove suction pipe bracket of coolant and lower hose from suction pipe.
6. Remove all spark plugs.

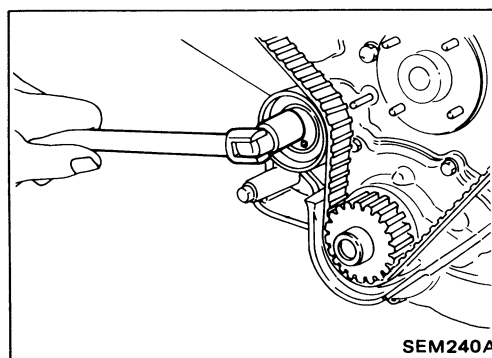
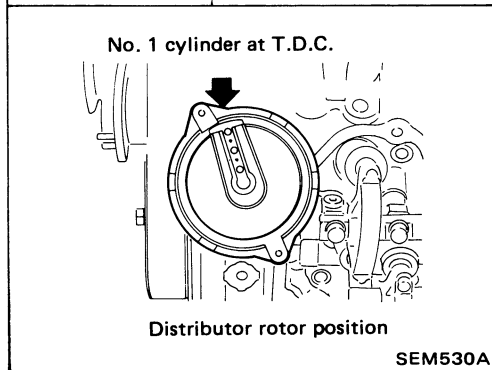
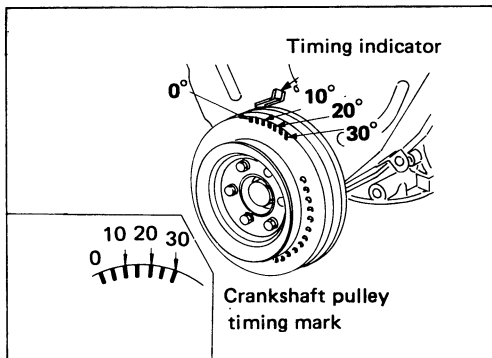

7. Set No. 1 cylinder at T.D.C. on its compression stroke.
8. Remove idler bracket of the compressor drive belt and crankshaft pulley.
9. Remove front upper and lower belt covers.
10. Loosen timing belt tensioner nut, turn tensioner, and then remove timing belt.

**Inspection (Cont'd)**

**VALVE DIMENSIONS**

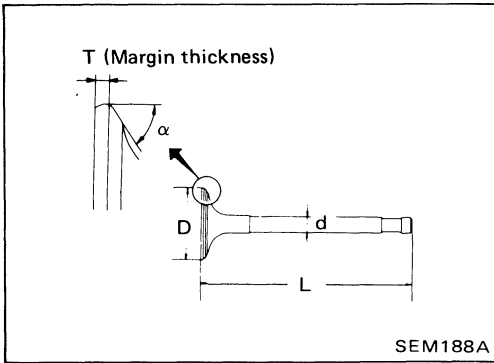

1. Check dimensions in each valve. For dimensions, refer to S.D.S.
2. When valve head has been worn down to 0.5 mm (0.020 in) in margin thickness, replace the valve.

**Grinding allowance for valve stem tip is 0.2 mm (0.008 in) or less.**

**VALVE SPRING SQUARENESS**

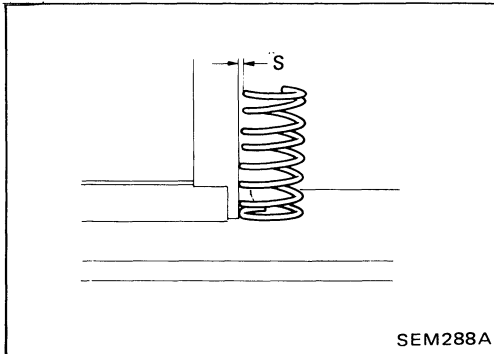

1. Measure "S" dimension.

**Out-of-square:**

**Outer**

**Less than 2.2 mm (0.087 in)**

**Inner**

**Less than 1.9 mm (0.075 in)**

2. If it exceeds the limit, replace spring.

**VALVE SPRING PRESSURE HEIGHT**

Check valve spring pressure height.

Pressure height: mm/N (mm/kg, in/lb)

**Standard**

**Outer 30.0/523.7 (30.0/53.4, 1.181/117.7)**

**Inner 25.0/255.0 (25.0/26.0, 0.984/57.3)**

**Limit**

**Outer 30.0/462.9 (30.0/47.2, 1.181/104.1)**

**Inner 25.0/225.6 (25.0/23.0, 0.984/50.7)**

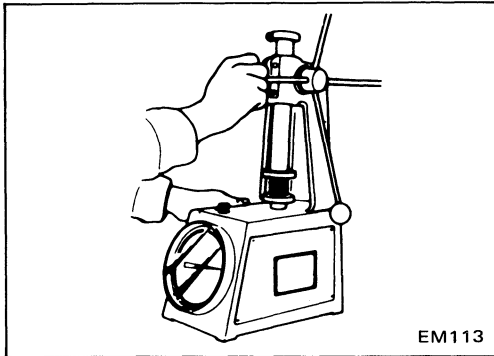

**HYDRAULIC VALVE LIFTER**

1. Check contact and sliding surfaces for wear or scratches.

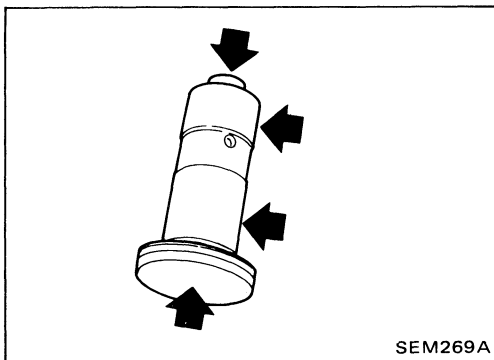

2. Check diameter of a valve lifter.

**Outer diameter:**

**15.947 - 15.957 mm (0.6278 - 0.6282 in)**

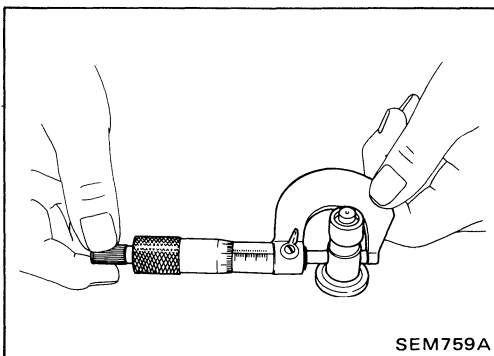

**Inspection (Cont'd)**  
**PISTON-TO-BORE CLEARANCE**

- Using a bore gauge, measure cylinder bore for wear, out-of-round or taper.

**Standard inner diameter:**

**87.00 - 87.05 mm (3.4252 - 3.4272 in)**

**Refer to S.D.S.**

**Out-of-round (X—Y):**

**Limit 0.015 mm (0.0006 in)**

**Taper (A-B-C):**

**Limit 0.015 mm (0.0006 in)**

If it exceeds the limit, rebore all cylinders. Replace cylinder block if necessary.

- Check for scratches or seizure. If seizure is found, hone it.

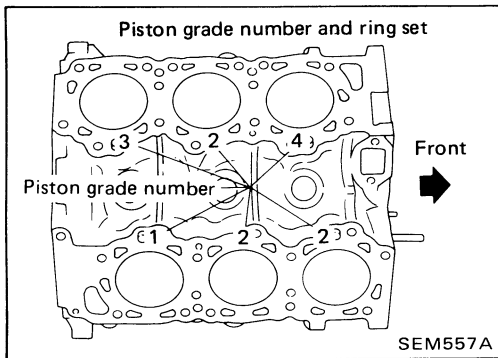
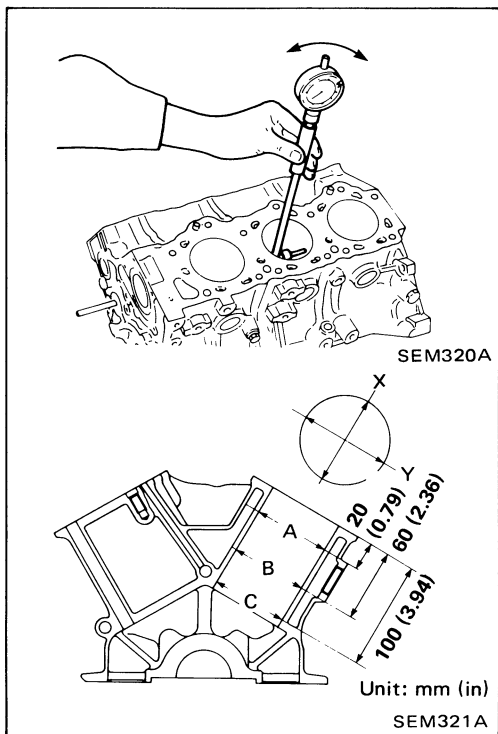

- If either cylinder block or piston is replaced with a new one, select piston of the same grade number punched on cylinder block upper surface.

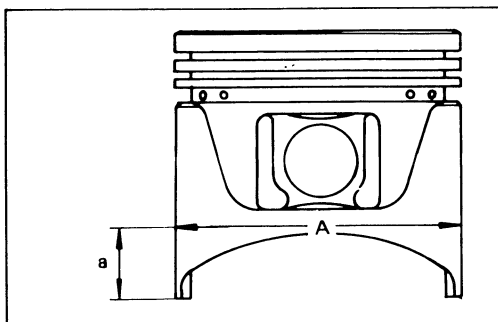

- Measure piston skirt diameter.

**Piston diameter "A":**

**Refer to S.D.S.**

**Measuring point "a" (Distance from the bottom):**

**20 mm (0.79 in)**

- Check that piston-to-bore clearance is within the specification.

**Piston-to-bore clearance "B":**

**0.025 - 0.045 mm (0.0010 - 0.0018 in)**

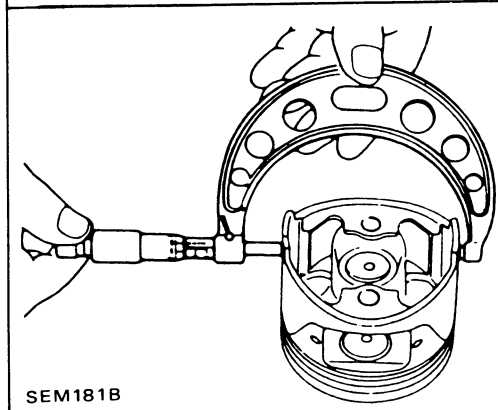

Tightening Torque

ENGINE OUTER PARTS

Unit	N·m	kg·m	ft·lb
Intake manifold bolt	16 - 20	1.6 - 2.0	12 - 14
Intake manifold nut	24 - 27	2.4 - 2.8	17 - 20
Thermal transmitter	15 - 20	1.5 - 2.0	11 - 14
Exhaust manifold	18 - 22	1.8 - 2.2	13 - 16
Exhaust connecting tube	22 - 27	2.2 - 2.8	16 - 20
Crankshaft pulley	123 - 132	12.5 - 13.5	90 - 98
Water inlet	16 - 21	1.6 - 2.1	12 - 15
P.C.V. valve	29 - 39	3.0 - 4.0	22 - 29
Distributor bolt	4.9 - 5.9	0.5 - 0.6	3.6 - 4.3
Alternator adjusting bar bolt	14 - 17	1.4 - 1.7	10 - 12
E.G.R. control valve	18 - 23	1.8 - 2.3	13 - 17
E.G.R. tube	34 - 44	3.5 - 4.5	25 - 33
Temperature sensor	12 - 16	1.2 - 1.6	9 - 12
Starter motor	30 - 36	3.1 - 3.7	22 - 27

ENGINE PARTS

Unit	N·m	kg·m	ft·lb
Rocker cover	1 - 3	0.1 - 0.3	0.7 - 2.2
Tensioner nut	43 - 58	4.4 - 5.9	32 - 43
Belt cover	3 - 5	0.3 - 0.5	2.2 - 3.6
Rocker shaft	18 - 22	1.8 - 2.2	13 - 16
Camshaft pulley	78 - 88	8.0 - 9.0	58 - 65
Cylinder head	Refer to "Installation" of CYLINDER HEAD.		
Camshaft locate plate	78 - 88	8.0 - 9.0	58 - 65
Water pump	16 - 21	1.6 - 2.1	12 - 15
Drain plug (Oil pan)	29 - 39	3.0 - 4.0	22 - 29
Oil pan	7 - 8	0.7 - 0.8	5.1 - 5.8
Oil pump regulator valve	39 - 69	4.0 - 7.0	29 - 51
Oil pump securing bolts	7 - 8	0.7 - 0.8	5.1 - 5.8
	22 - 29	2.2 - 3.0	16 - 22
Oil strainer	16 - 21	1.6 - 2.1	12 - 15
Oil strainer bracket	4 - 8	0.4 - 0.8	2.9 - 5.8
Flywheel	98 - 108	10 - 11	72 - 80
Rear oil seal retainer	6 - 7	0.6 - 0.7	4.3 - 5.1
Connecting rod	Refer to "Installation" of ENGINE OVERHAUL.		
Main bearing cap	90 - 100	9.2 - 10.2	67 - 74
Water drain plug	34 - 44	3.5 - 4.5	25 - 33
Spark plug	20 - 29	2.0 - 3.0	14 - 22

1. Drain coolant from radiator.  
**Be careful not to spill coolant on drive belts.**
2. Remove the following parts.
  - Power steering pump drive belt
  - Power steering pump, idler pulley and power steering brackets
3. Disconnect front exhaust tube from exhaust manifold.

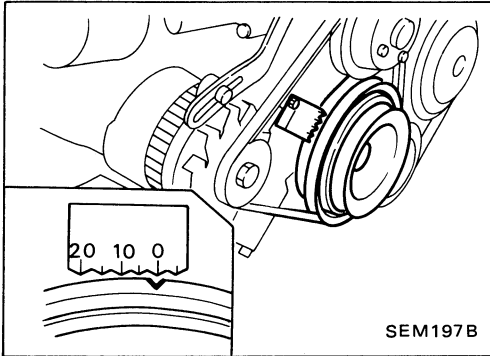

4. Remove rocker cover.
5. Set No. 1 cylinder at T.D.C. on its compression stroke as the distributor rotor points in the direction shown in the figure.

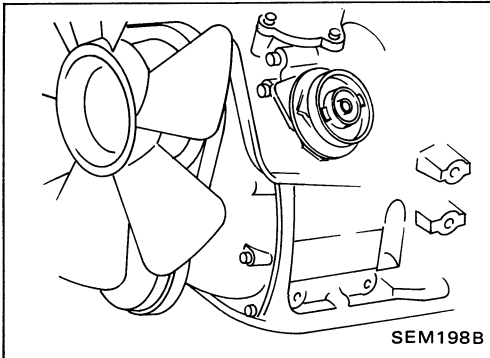

6. Loosen camshaft sprocket bolt.
7. Support timing chain by using Tool between timing chain.



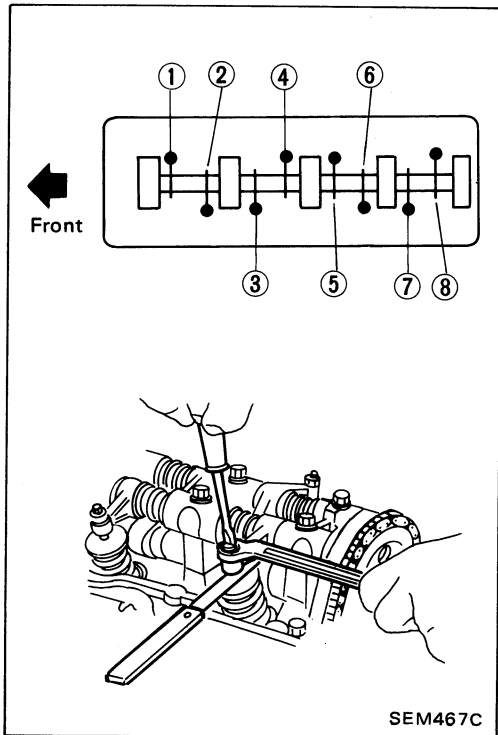

6. Adjust valve clearance.

- (1) Set No. 1 cylinder to top dead center on its compression stroke, and adjust valve clearance ①, ②, ④ and ⑥.
- (2) Again, rotate crankshaft one turn so that No. 4 cylinder is at top dead center of its compression stroke, and adjust valve clearance ③, ⑤, ⑦ and ⑧.

Valve clearance:

Unit: mm (in)

	COLD*	HOT
Intake	0.21 (0.008)	0.3 (0.012)
Exhaust	0.23 (0.009)	0.3 (0.012)

\*: At a temperature of approximately 20°C (68°F)

Adjusting screw lock nuts:

 : 16 - 22 N·m (1.6 - 2.2 kg·m, 12 - 16 ft·lb)

7. Install the following parts.

- Rocker cover
- Power steering pump, idler pulley and brackets.
- Power steering pump drive belt

8. Connect exhaust manifold and exhaust tube.

General Specifications

Cylinder arrangement	In-line-4
Displacement cm <sup>3</sup> (cu in)	2,389 (145.78)
Bore and Stroke mm (in)	89 x 96 (3.50 x 3.78)
Valve arrangement	O.H.C.
Firing order	1-3-4-2
Number of piston rings	
Compression	2
Oil	1
Number of main bearings	5
Compression ratio	8.3

Unit: kPa (kg/cm<sup>2</sup>, psi)/rpm

Compression pressure	
Standard	1,196 (12.2, 173)/350
Minimum	902 (9.2, 131)/350
Differential limit between cylinders	98 (1.0, 14)/350

Inspection and Adjustment

CYLINDER HEAD

Unit: mm (in)

	Limit
Head distortion	0.1 (0.004)
Head height (Nominal)	98.9±0.2 (3.894±0.008)

VALVE

Unit: mm (in)

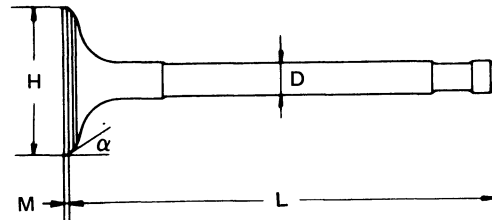

SEM181

		Standard	Limit
Valve head diameter "H"	In.	42.0 - 42.2 (1.654 - 1.661)	—
	Ex.	38.0 - 38.2 (1.496 - 1.504)	—
Valve length "L"	In.	122.8 - 123.1 (4.835 - 4.846)	—
	Ex.	123.6 - 123.9 (4.866 - 4.878)	—
Valve stem diameter "D"	In.	7.965 - 7.980 (0.3136 - 0.3142)	—
	Ex.	7.945 - 7.960 (0.3128 - 0.3134)	—
Valve face angle "alpha"	In.	45° 30' ± 15'	—
	Ex.		
Valve head margin "M"	In.	1.3 (0.051)	0.5 (0.020)
	Ex.	1.5 (0.059)	0.5 (0.020)
Grinding of valve stem end	In.	—	0.2 (0.008)
	Ex.		

## Oil Pressure Check

### WARNING:

- Be careful not to burn yourself, as the engine and oil may be hot.
- Oil pressure check should be done in "Neutral" gear position.

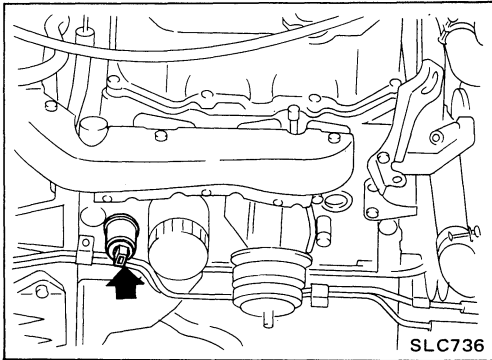

1. Check oil level.
2. Remove oil pressure switch.

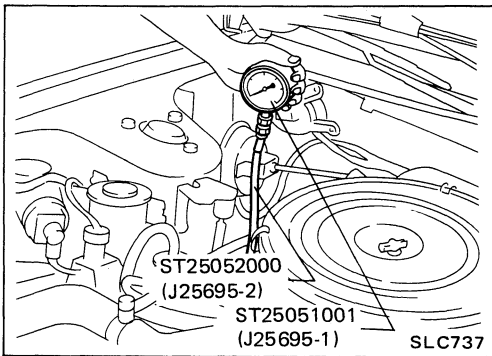

3. Install pressure gauge.
4. Start engine and warm it up to normal operating temperature, and then check oil pressure with engine running under no-load.

Engine rpm	Approximate discharge pressure kPa (kg/cm <sup>2</sup> , psi)
Idle speed 3,200	More than 59 (0.6, 9) 363 - 461 (3.7 - 4.7, 53 - 67)

If difference is extreme, check oil passage and oil pump for oil leaks.

5. Install oil pressure switch.

Use proper liquid sealant.

Oil pressure switch:

: 10 - 16 N·m  
(1.0 - 1.6 kg-m, 7 - 12 ft-lb)

Cooling Circuit

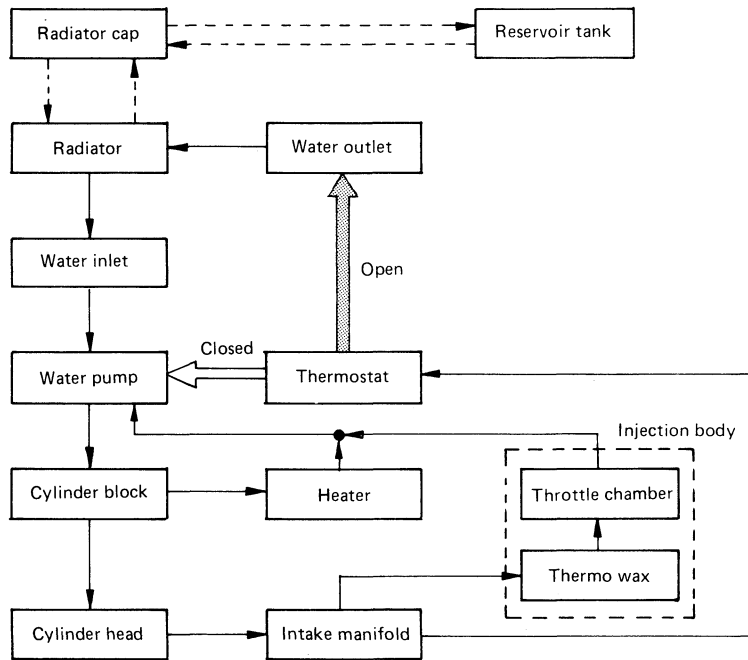
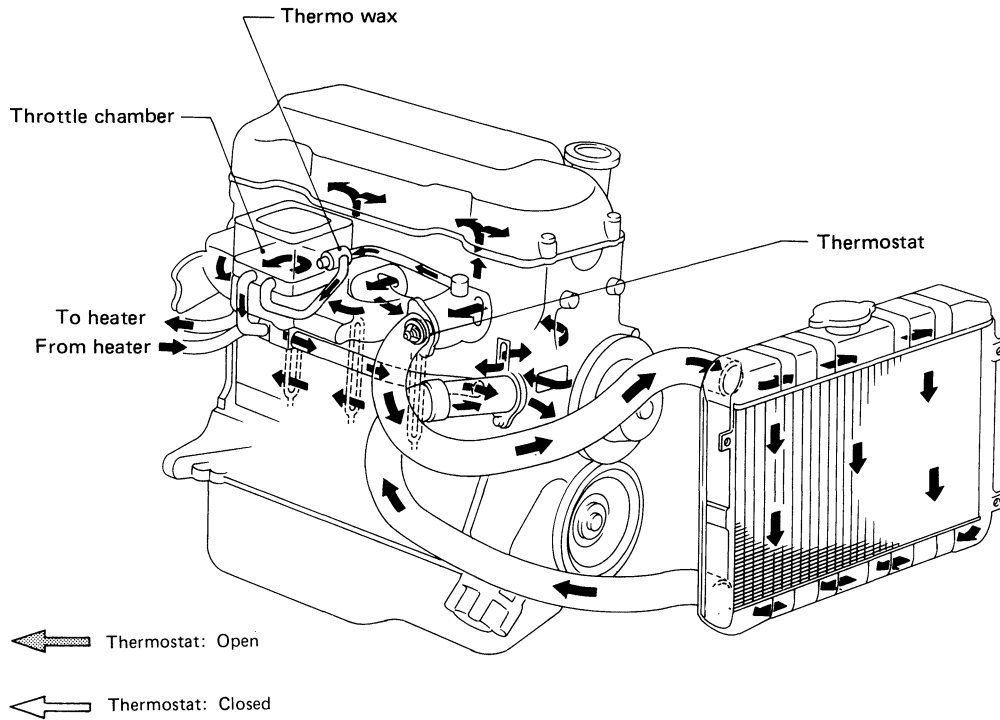

SLC774

**WARNING:**

To avoid serious personal injury, never remove radiator cap quickly when engine is hot. Sudden release of cooling system pressure is very dangerous.

If it is necessary to remove radiator cap when radiator is hot, turn cap slowly counterclockwise to the first stop. After all pressure in the cooling system is released, turn cap passing the stop and remove it.

# E.C.C.S. DIAGRAM

VG30i

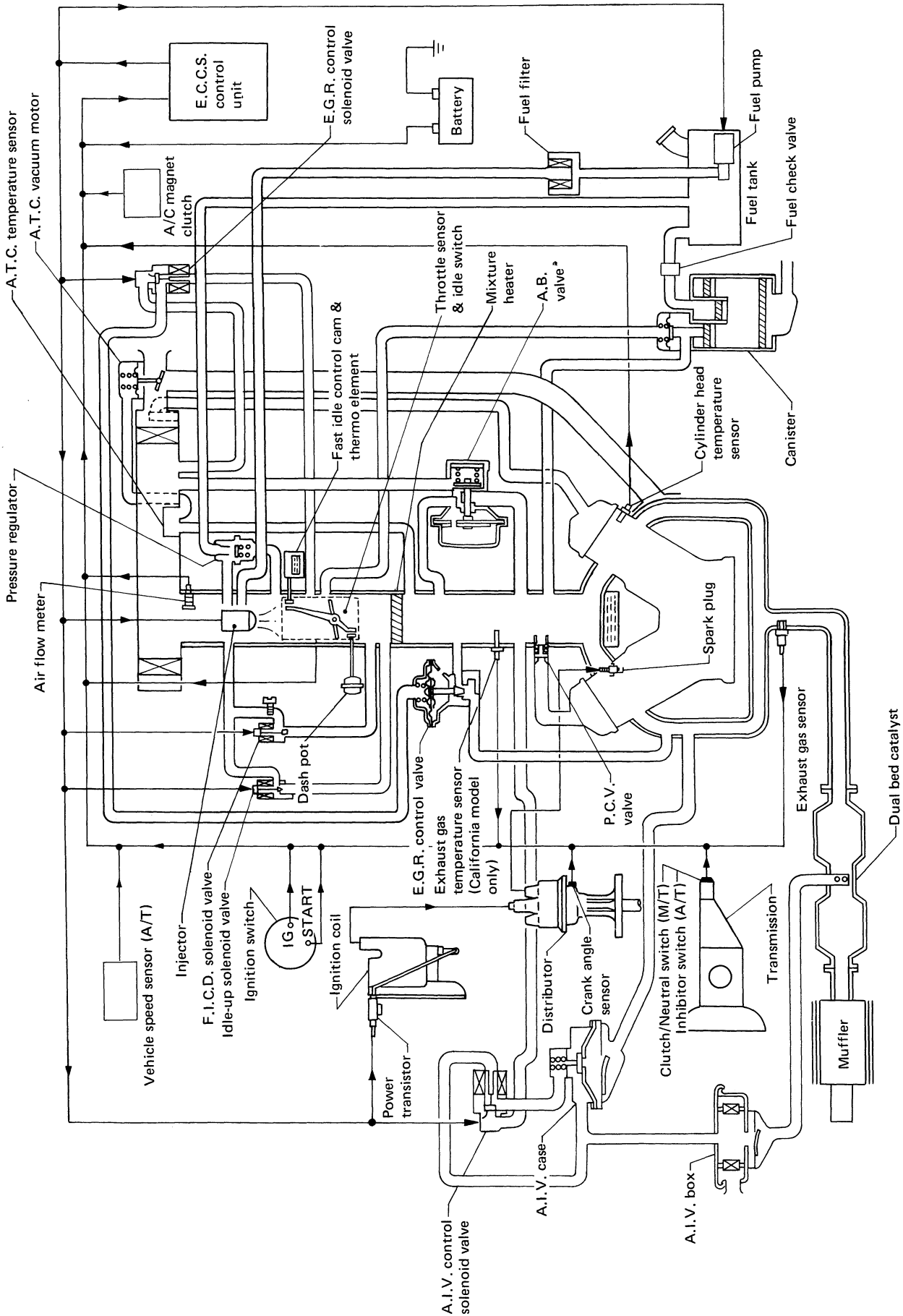

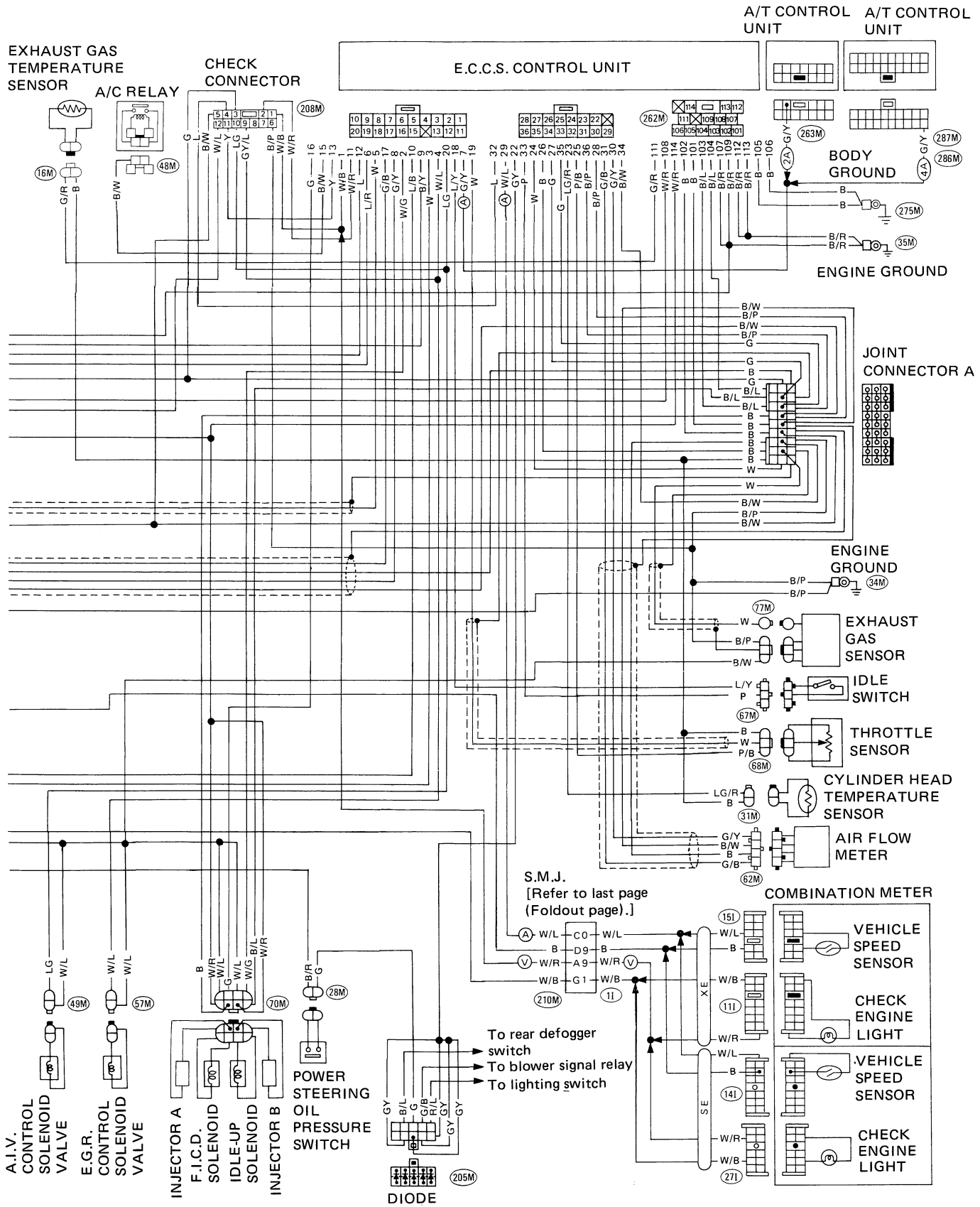

Fuel Pump Control

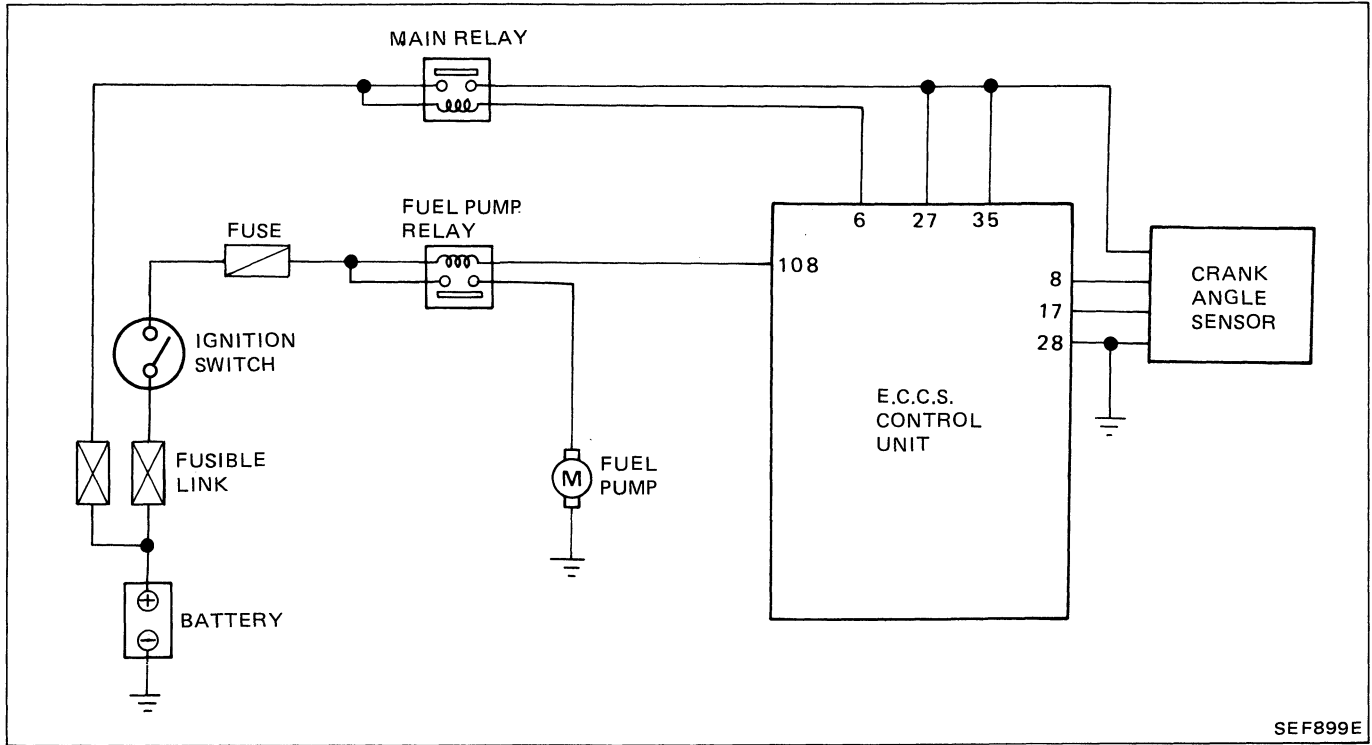
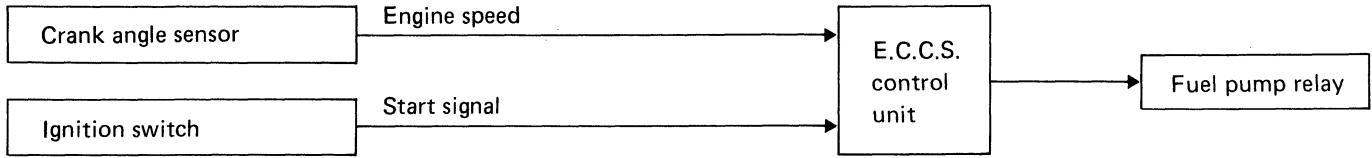

Fuel pump ON-OFF control

Ignition switch position	Engine condition	Fuel pump relay	Fuel pump operation
ON	Stopped	ON → OFF	Operates for a few seconds after ignition switch turns to "ON"
	Starting	ON	Operates
	Running	ON	Operates
	After stall	OFF	Stops in 1 second

## Diagnostic Table (Cont'd)

**SYMPTOM & CONDITION**    **2**    Impossible to start – partial combustion

POSSIBLE CAUSES		1	2	3	4	5
<b>SPECIFICATIONS</b>	Mixture ratio	○	○	○		
	Fuel pressure (too low)				○	
	Ignition timing					○
<b>FUEL SYSTEM</b>	Fuel pump	○				
	Fuel pump relay (open circuited)	○				
	Injectors (clogged)		○			

### SERVICE PROCEDURE

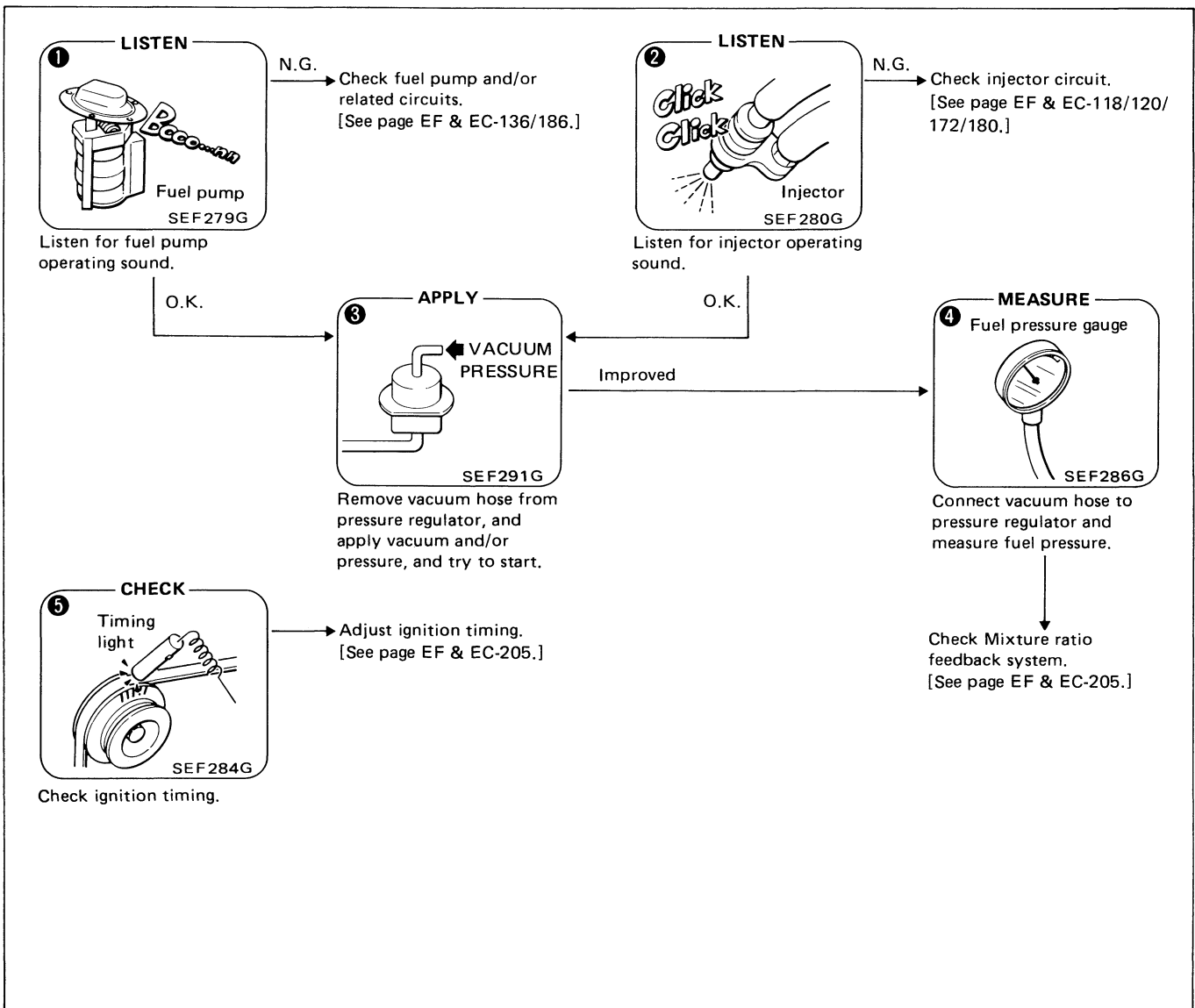

## Diagnostic Table (Cont'd)

### SYMPTOM & CONDITION 15 Poor driveability – surge (while cruising)

POSSIBLE CAUSES		1	2	3	4	5	6	7	8	9
<b>SPECIFICATIONS</b>	Mixture ratio (too lean)	○				○	○			○
	Fuel pressure (low)					○	○			
	Ignition timing		○							
<b>IGNITION SYSTEM</b>	(missing)								○	
<b>INTAKE SYSTEM</b>	Air duct (leaks)	○								
	Throttle chamber (air leaks)	○								
	Intake manifold (gasket) (air leaks)	○								
<b>CONTROL SYSTEM</b>	Crank angle sensor								○	
	Air flow meter								○	
	Exhaust gas sensor								○	○
	Idle switch							○		
<b>E.G.R. SYSTEM</b>	E.G.R. control valve (stuck open)			○						
	E.G.R. solenoid (remaining OFF)			○	○					
	E.G.R. vacuum hose (removed)			○						

### SERVICE PROCEDURE

**1 CHECK**

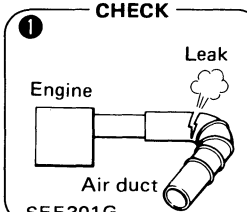

Leak  
Engine  
Air duct  
SEF301G

Check intake system for air leaks.  
↓ N.G.  
Repair/replace the part.

**2 CHECK**

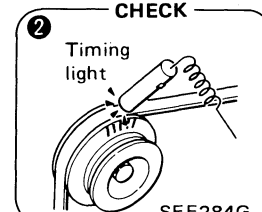

Timing light  
SEF284G

Check ignition timing.  
↓ N.G.  
Adjust ignition timing.  
[See page EF & EC-205.]

**3 CHECK**

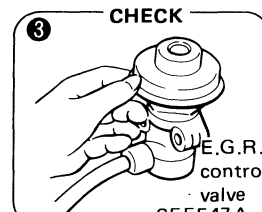

E.G.R. control valve  
SEF547A

Check E.G.R. control valve for operation.

**4 CHECK**

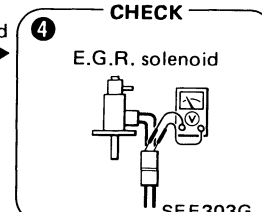

E.G.R. solenoid  
SEF303G

Check terminal voltage of E.G.R. solenoid.  
↓ N.G.  
Check the solenoid circuit.  
[See page EF & EC-104/158.]

**5 REMOVE**

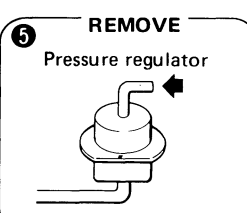

Pressure regulator  
SEF291G

Remove vacuum hose from pressure regulator, and try to drive.

**6 MEASURE**

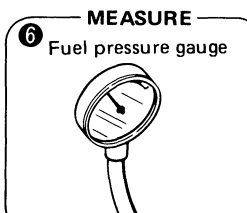

Fuel pressure gauge  
SEF286G

Connect vacuum hose to pressure regulator and measure fuel pressure while driving.

**7 PERFORM**

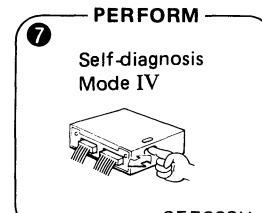

Self-diagnosis Mode IV  
SEF363H

Perform self-diagnosis Mode IV (for idle switch).  
↓ N.G.  
Check the idle switch circuit.  
[See page EF & EC-122/174.]

**8 PERFORM**

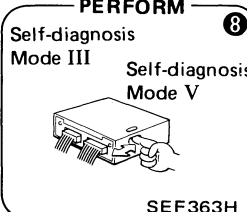

Self-diagnosis Mode III  
Self-diagnosis Mode V  
SEF363H

Perform self-diagnosis Mode III and V (for crank angle sensor, air flow meter, ignition signal and exhaust gas sensor).  
↓ N.G. →

**9 DISCONNECT**

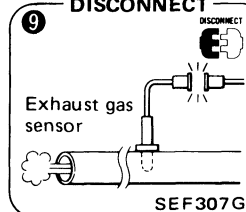

Exhaust gas sensor  
SEF307G

Disconnect exhaust gas sensor connector, and try to drive.

Improved →

No change → Check mixture ratio feedback system. [See page EF & EC-205.]

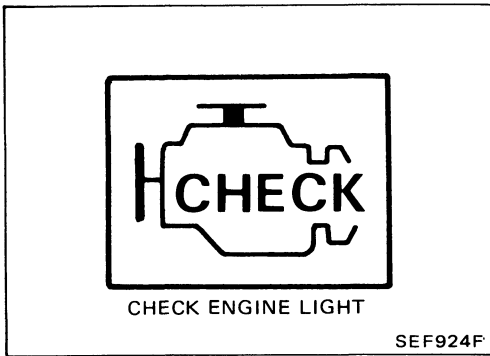

**Description (Cont'd)**

**CHECK ENGINE LIGHT**  **(For California only)**

This vehicle has a check engine light on instrument panel. This light comes ON under the following conditions:

- 1) When ignition switch is turned "ON" (for bulb check).
- 2) When systems related to emission performance malfunction in Mode I (with engine running).
  - This check engine light always illuminates and is synchronous with red L.E.D.
  - Malfunction systems related to emission performance can be detected by self-diagnosis, and they are clarified as self-diagnostic codes in Mode III.
- 3) Check engine light will come "ON" only when malfunction is sensed.

The check engine light will turn off when normal operation is resumed. Mode III memory must be cleared as the contents remain stored.

Code No.	Malfunction
12	Air flow meter circuit
13	Cylinder head/water temperature sensor circuit
31	E.C.U. (E.C.C.S. control unit)
32	E.G.R. function
33	Exhaust gas sensor circuit
35	Exhaust gas temperature sensor circuit
43	Throttle sensor circuit
45	Injector leak

Use the following diagnostic flowchart to check and repair a malfunctioning system.

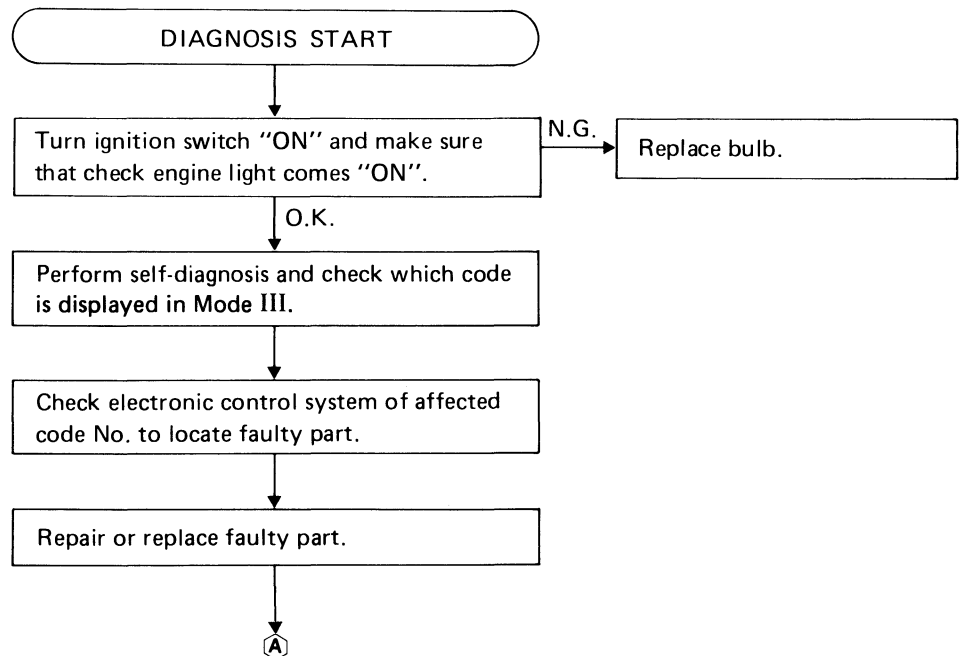

Mode V — Real Time Diagnostic System  
(Cont'd)

REAL TIME DIAGNOSTIC INSPECTION

**Crank Angle Sensor**

X: Available  
—: Not available

Check sequence	Check items	Check conditions	Check parts			If malfunction, perform the following items.
			Middle connector	Sensor & actuator	E.C.U. 20 & 16 pin connector	
1	Tap harness connector or component during real time diagnosis.	During real time diagnosis	X	X	X	Go to check item 2.
2	Check harness continuity at connector.	Engine stopped	X	—	—	Go to check item 3.
3	Disconnect harness connector, and then check dust adhesion to harness connector.	Engine stopped	X	—	X	Clean terminal surface.
4	Check pin terminal bend.	Engine stopped	—	—	X	Take out bend.
5	Reconnect harness connector and then recheck harness continuity at connector.	Engine stopped	X	—	—	Replace terminal.
6	Tap harness connector or component during real time diagnosis.	During real time diagnosis	X	X	X	If malfunction codes are displayed during real time diagnosis, replace terminal.

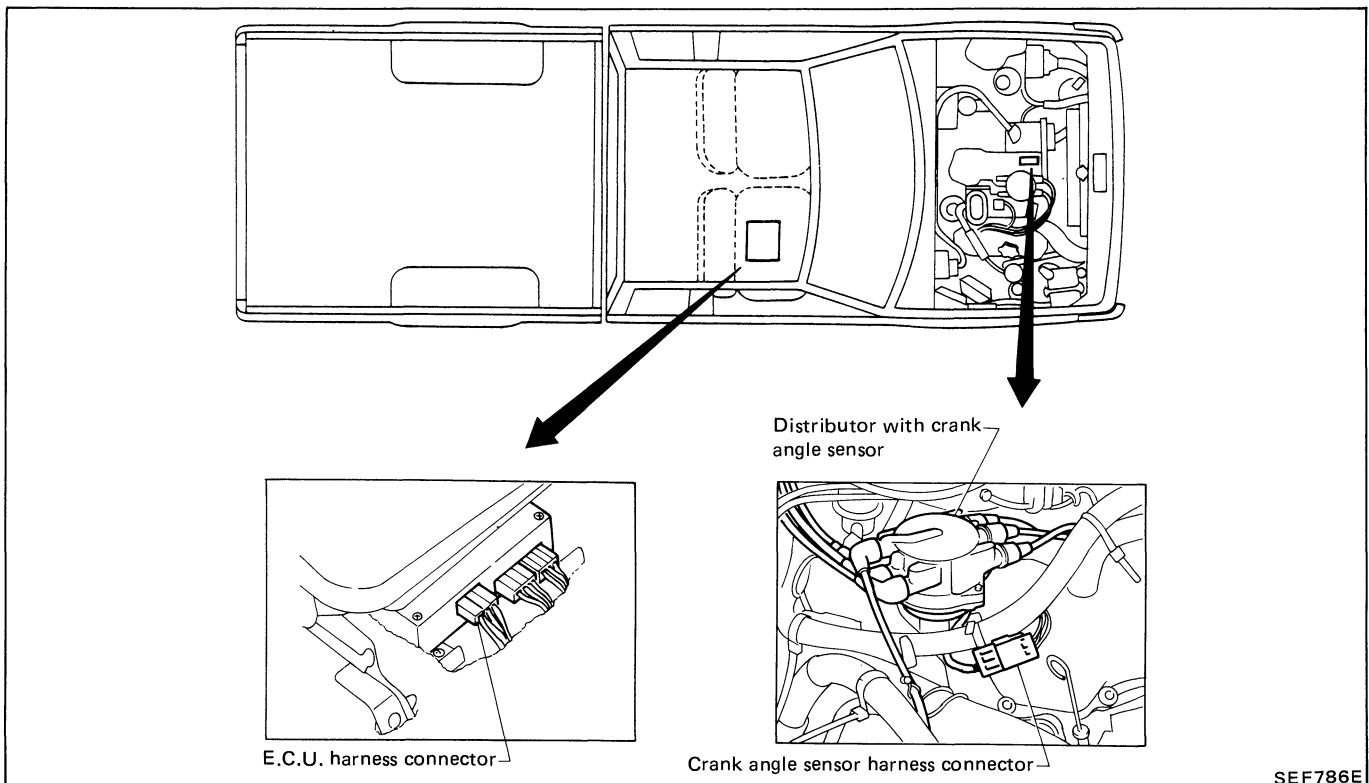

SEF786E

CYLINDER HEAD TEMPERATURE SENSOR (Code No. 13)  (CHECK ENGINE LIGHT ITEM)

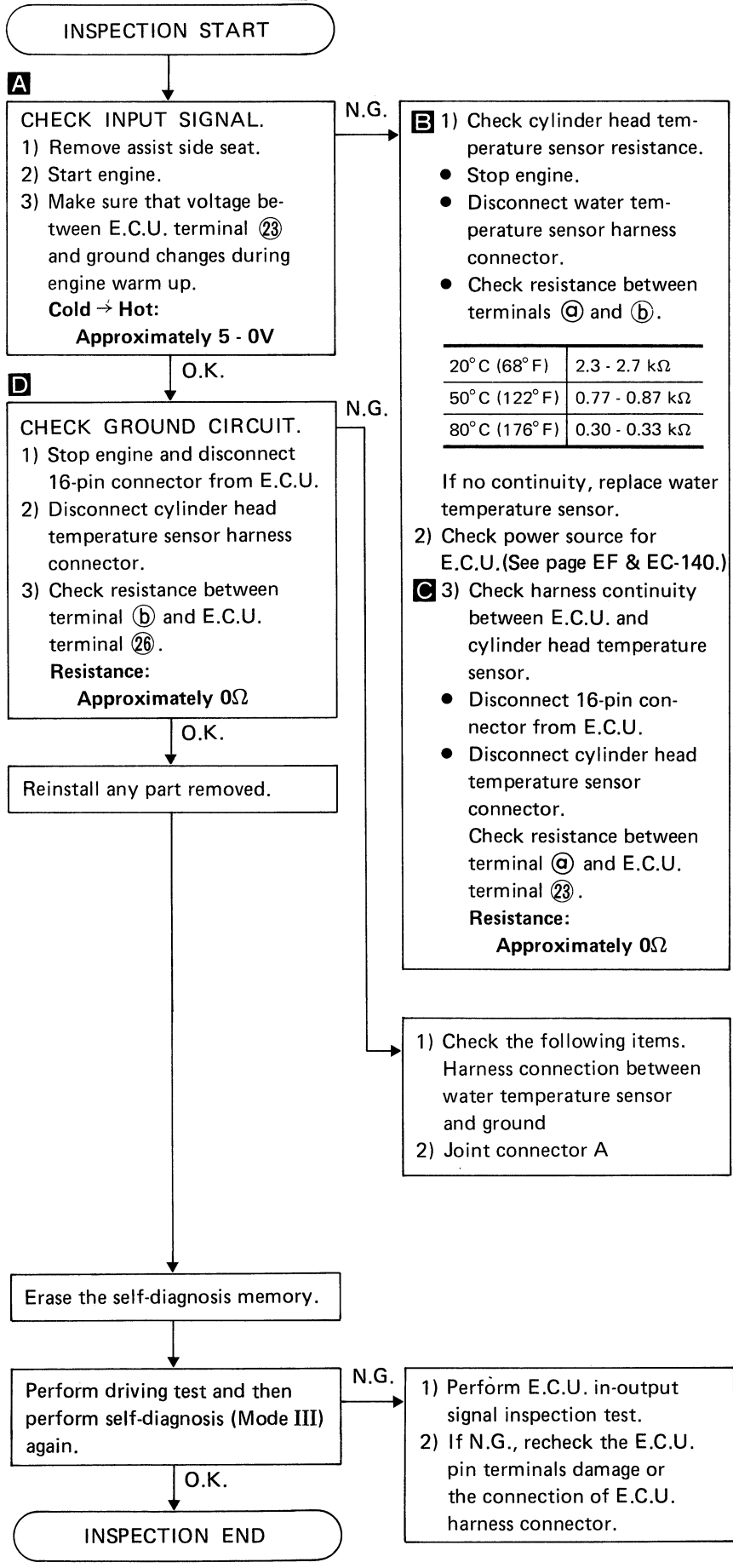
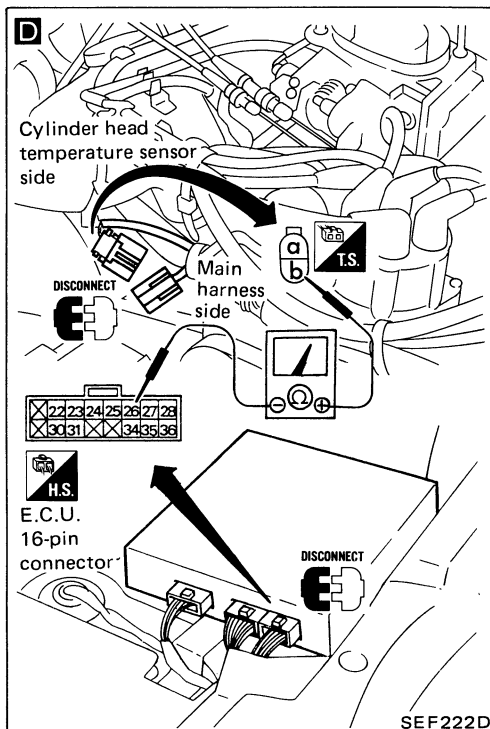
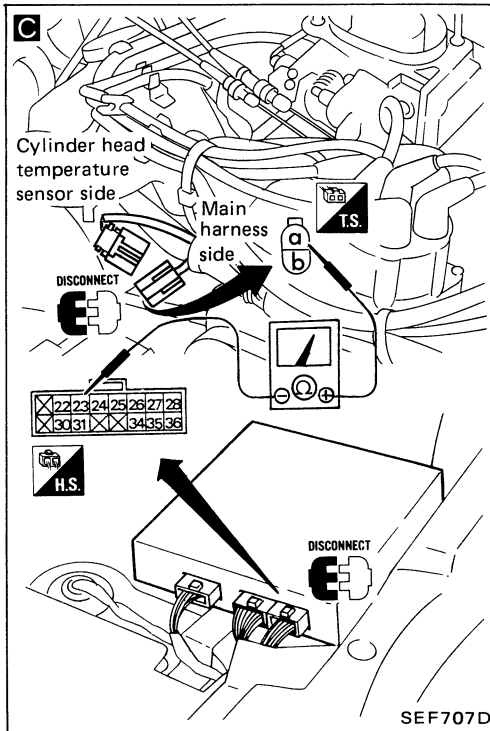
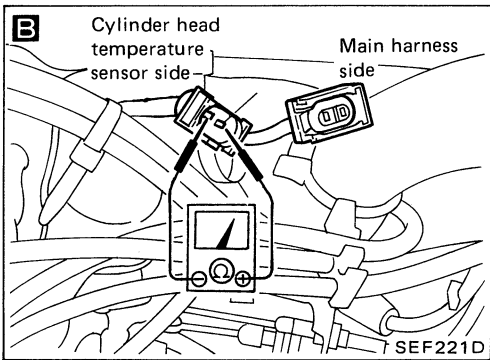

EXHAUST GAS TEMPERATURE SENSOR (Code No. 35)  (CHECK ENGINE LIGHT ITEM); CALIFORNIA MODEL ONLY

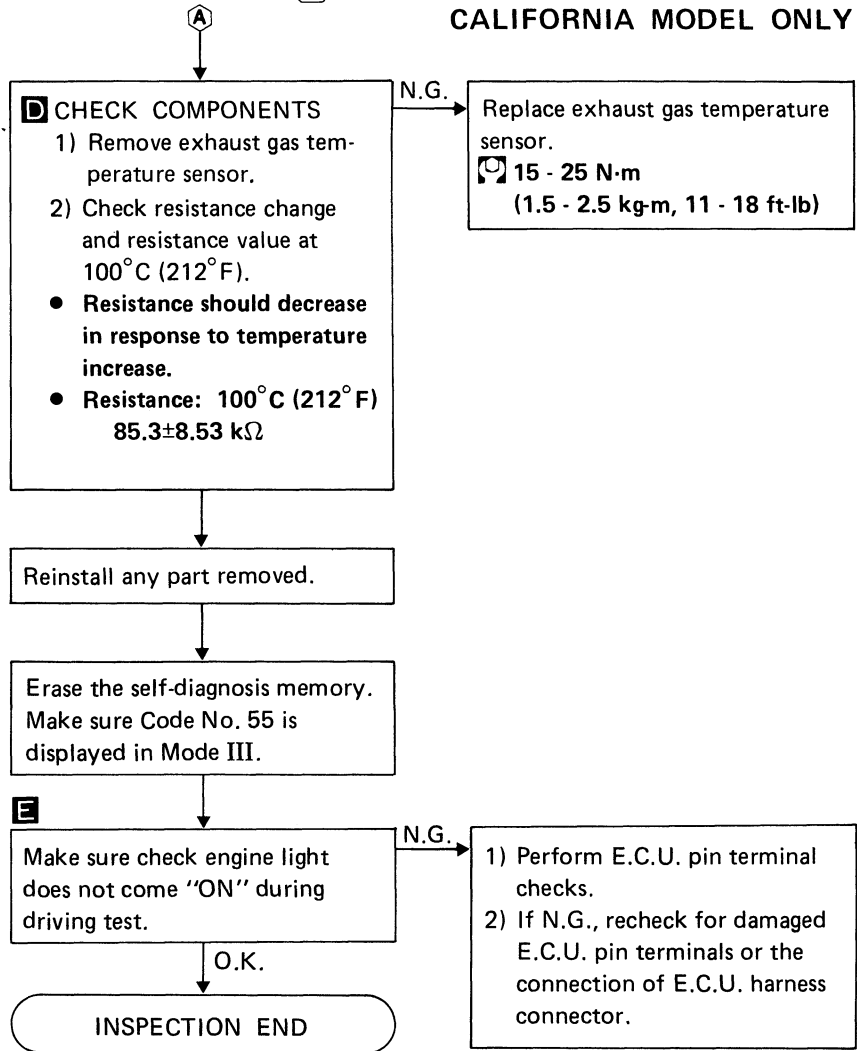

STARTER SWITCH (Switch ON/OFF diagnosis)

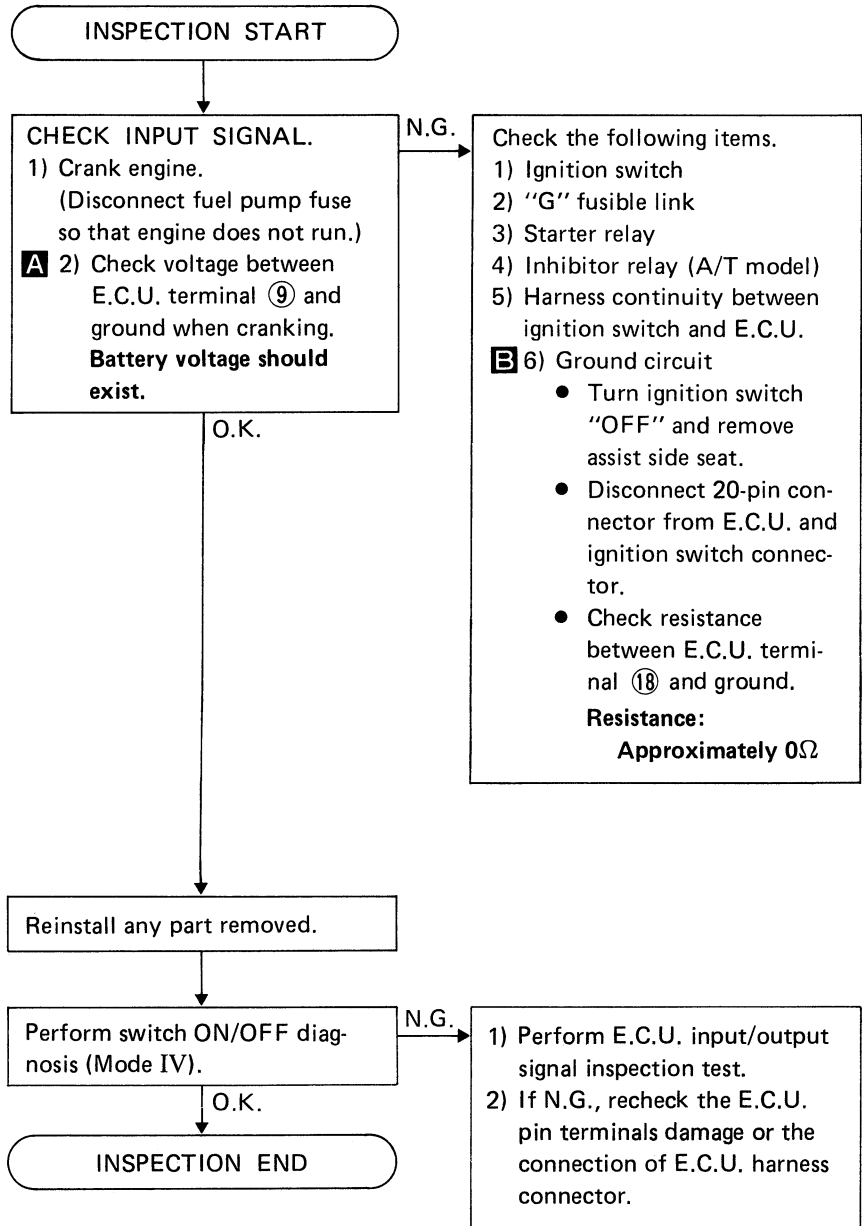
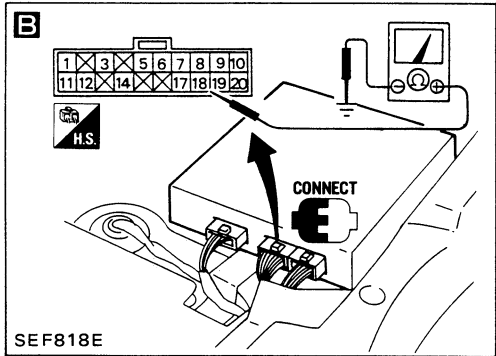
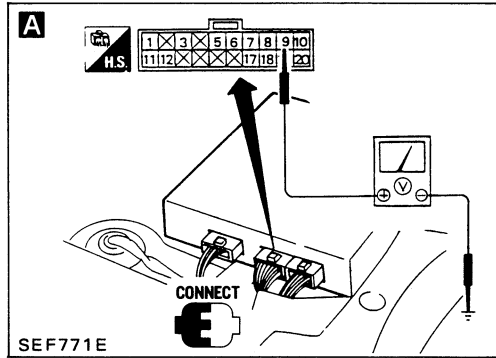

## FUEL PUMP RELAY (Not self-diagnostic item)

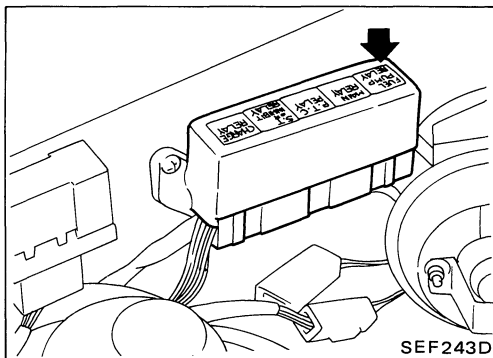
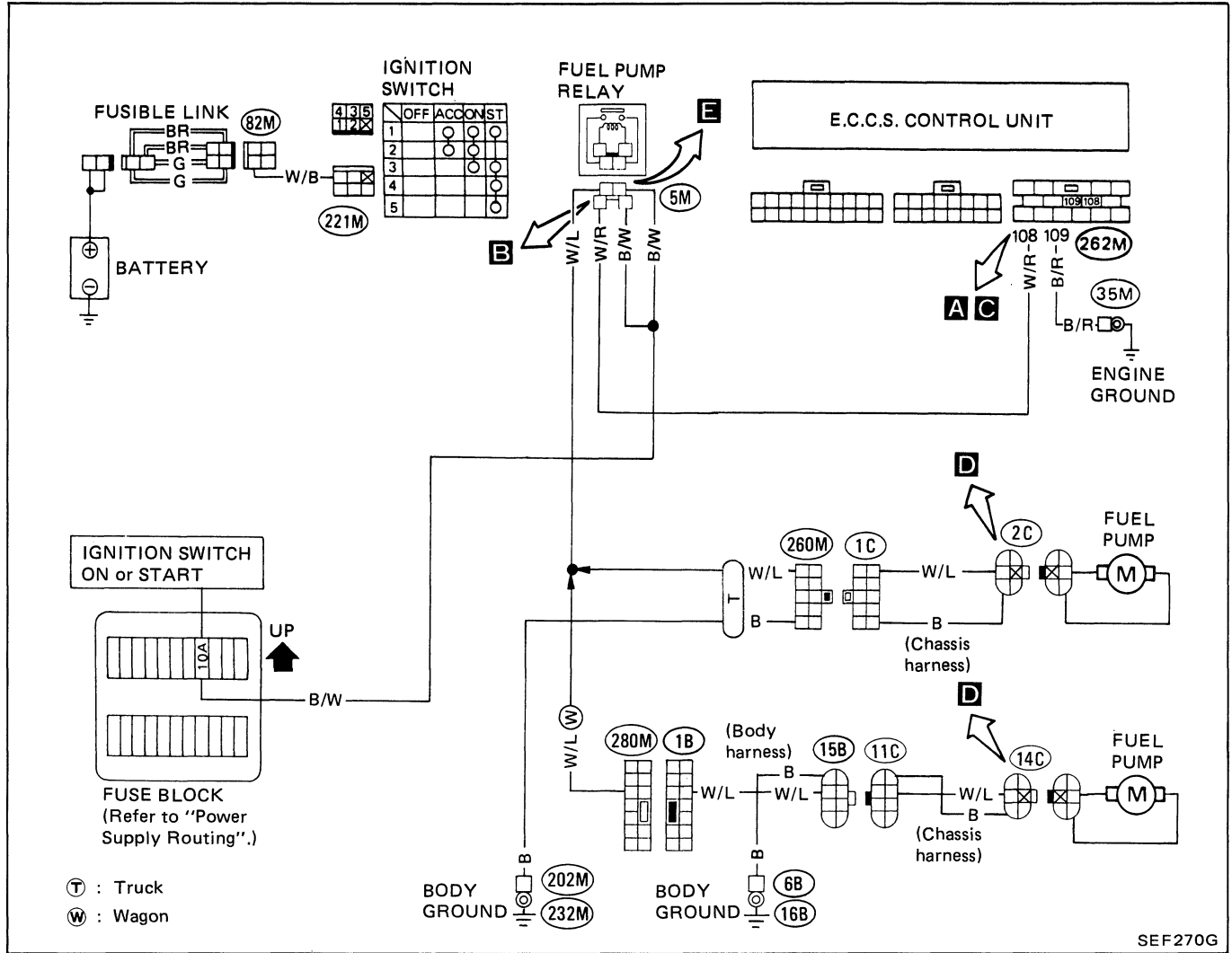

**Fuel pump relay location**

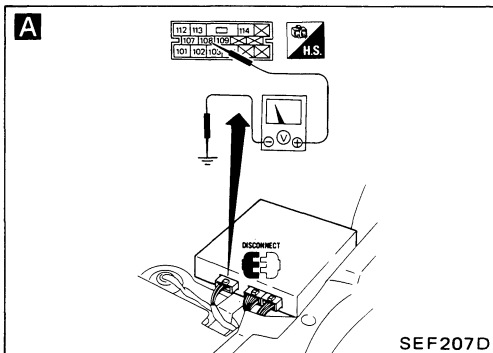

## AIR FLOW METER (Code No. 12) CHECK (CHECK ENGINE LIGHT ITEM)

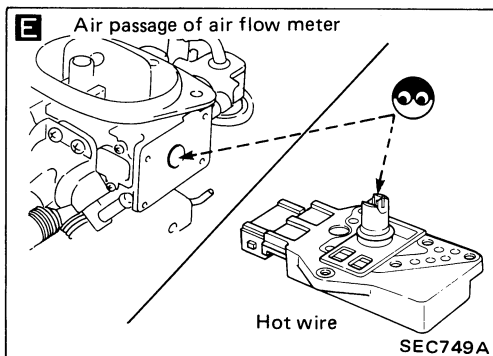
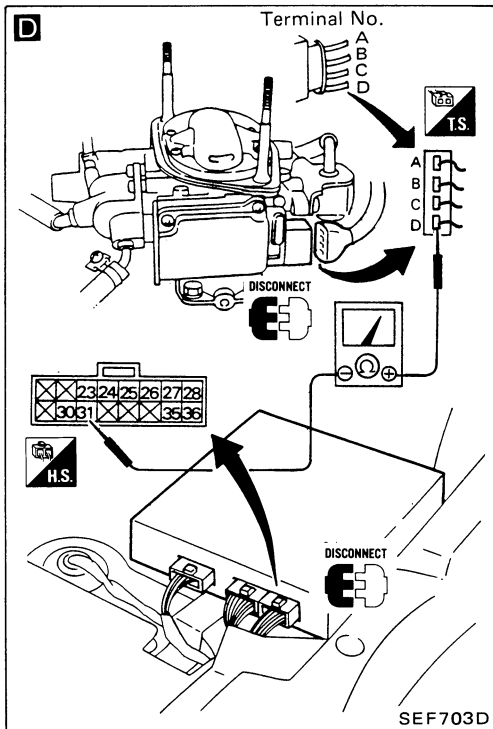
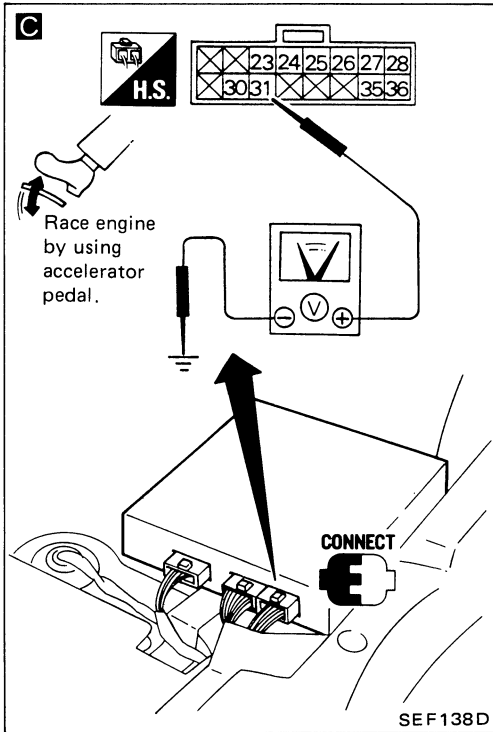

**C**

**CHECK E.C.U. INPUT SIGNAL.**

- 1) Remove assist side seat.
- 2) Reconnect air flow meter harness connector.
- 3) Start engine.
- 4) Make sure that voltage between E.C.U. terminal ③① and ground changes by racing engine with accelerator pedal. **Output voltage should change. 0 ~ Approximately 5.0V**

N.G. → **D**

**D**

Check harness continuity between E.C.U. and air flow meter.

- Stop engine.
- Disconnect air flow meter harness connector.
- Disconnect E.C.U. 16-pin harness connector.
- Check resistance between terminal D and E.C.U. terminal ③①.

**Resistance:**  
**Approximately 0Ω**  
If O.K., replace air flow meter.

O.K. → **E**

**E**

**CHECK AIR PASSAGE OF AIR FLOW METER**

- 1) Remove air flow meter from injector body.
- 2) Make sure that air passage of air flow meter in injection body or hot wire is not wet with fuel.

Wet → **D**

Not wet

Reinstall any part removed.

Erase the self-diagnosis memory.

Perform driving test and then perform self-diagnosis (Mode III) again.

N.G. → **D**

**D**

- 1) Perform E.C.U. input/output signal inspection test.
- 2) If N.G., recheck the E.C.U. pin terminals damage or the connection of E.C.U. harness connector.

O.K. → **INSPECTION END**

## EXHAUST GAS TEMPERATURE SENSOR (Code No. 35) (CHECK ENGINE LIGHT ITEM); CALIFORNIA MODEL ONLY

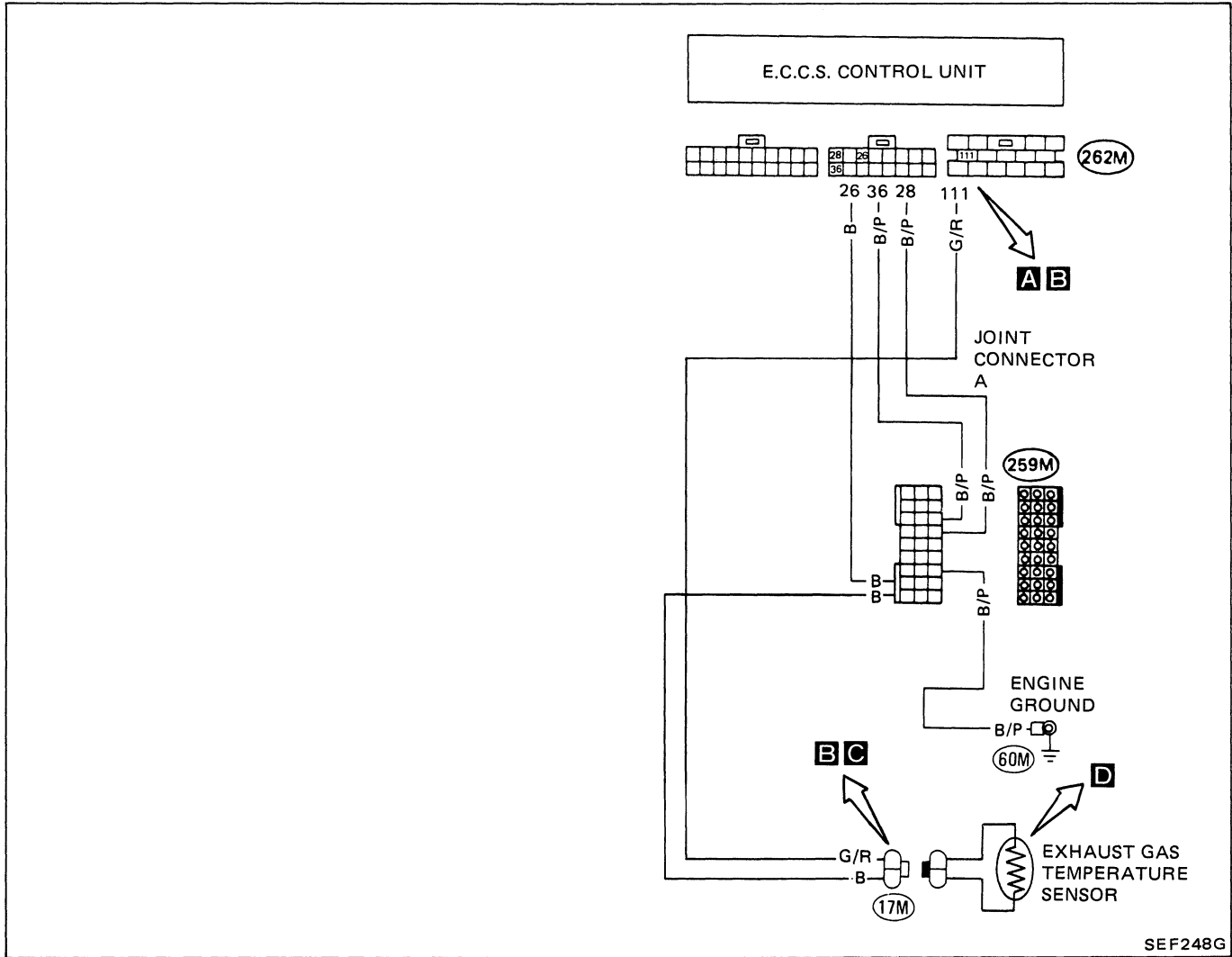

The following is necessary to perform this inspection.

1. Pull out E.C.U. installed under the assist seat.
2.
  - Disconnect vacuum hose connected to E.G.R. control valve.
  - Connect a hand vacuum pump to E.G.R. control valve.
3. Warm up engine sufficiently.

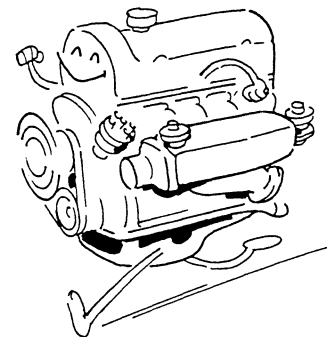
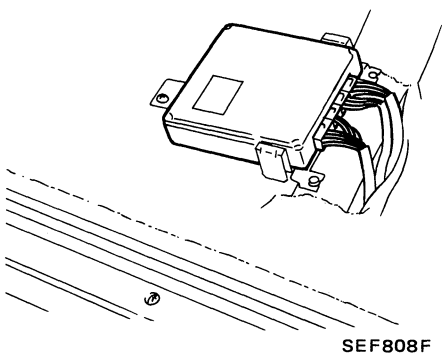

## STARTER SWITCH (Switch ON/OFF diagnosis)

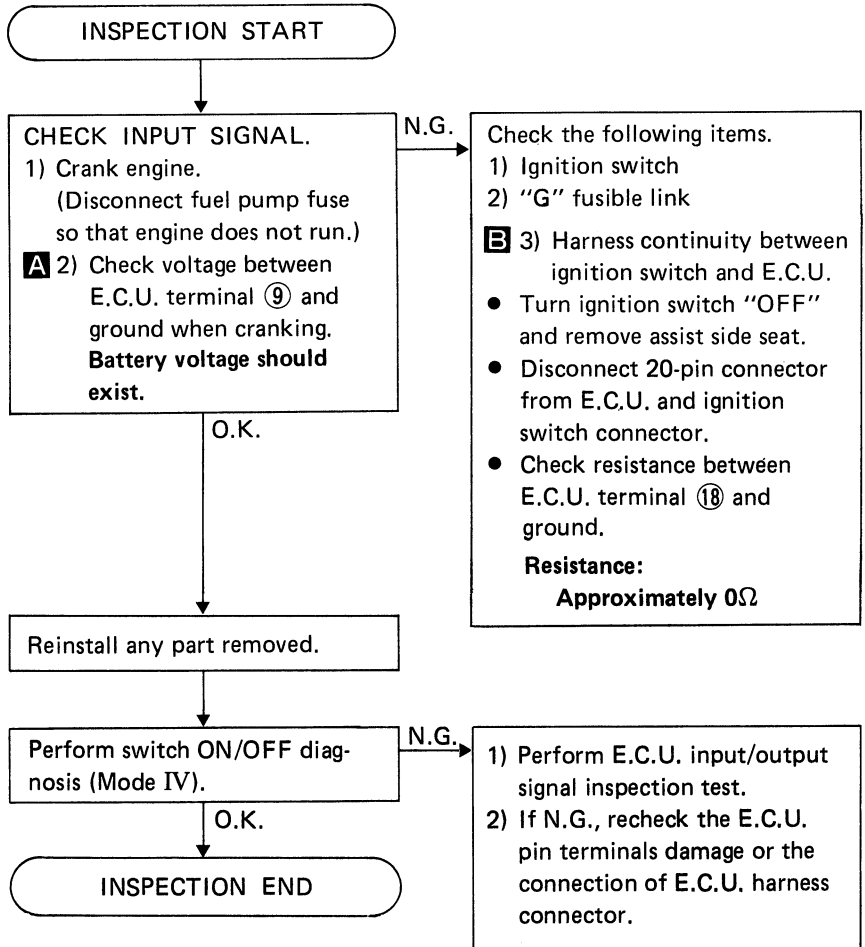
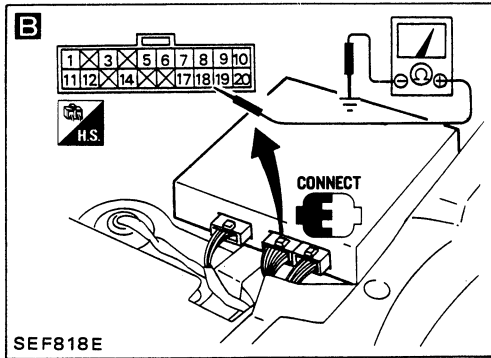
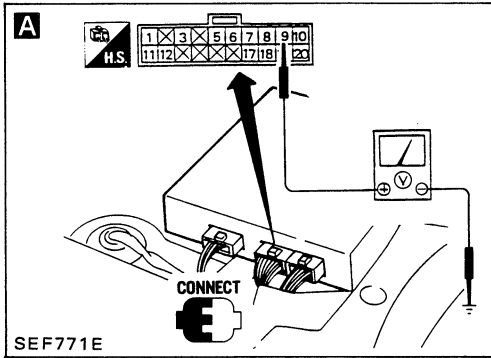



\*Data are reference values.

TERMI- NAL NO.	ITEM	CONDITION	*DATA	ENGINE	
				VG30i	Z24i
19	Throttle sensor	Ignition switch "ON" Inspection should be done after warming up engine sufficiently.	0.4 - 4.0V Output voltage varies with the throttle valve opening angle.	○	○
20	A.I.V. cut solenoid	Engine is running. └ Engine is cold. [ Water temperature is below 15°C (59°F). ]	0.8 - 0.9V	○	○ (Only 2WD)
		Engine is running. └ During warming up [ Water temperature is between 15°C (59°F) and 40°C (104°F). ]	BATTERY VOLTAGE (11 - 14V)		
		Engine is running. └ After warming up. [ Water temperature is above 40°C (104°F). ]  Idle condition after 3,000 rpm no load driving for 10 seconds  When depressing accelerator pedal at the above condition.	0.8 - 0.9V  BATTERY VOLTAGE (11 - 14V)		
22	Load signal	Engine is running. └ Steering wheel is turned. └ Blower switch is "ON". └ Headlamps are in high beam.	BATTERY VOLTAGE (11 - 14V)	○	
		Engine is running. └ Except the conditions shown above	Approximately 0V		
23	Water or cylinder head temperature sensor	Engine is running.	1.0 - 5.0V Output voltage varies with engine water temperature.	○	○
24	Exhaust gas sensor	Engine is running. └ After warming up suf- ficiently.	0 - Approximately 1.0V	○	○

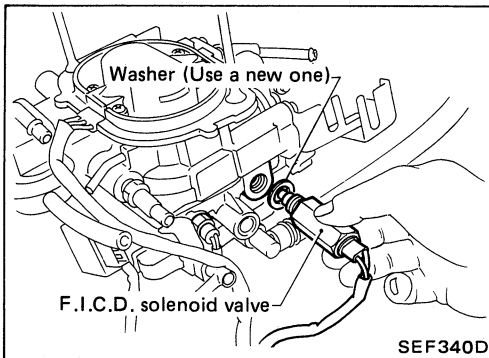

## F.I.C.D. Inspection and Adjustment (Cont'd)

- Replace the solenoid valve with a new one, if it has no electric continuity in spite of enough power supply.

☞ : F.I.C.D. solenoid valve  
 18 - 29 N·m  
 (1.8 - 3.0 kg-m, 13 - 22 ft-lb)

### CAUTION:

Use a new washer when removing solenoid valve.

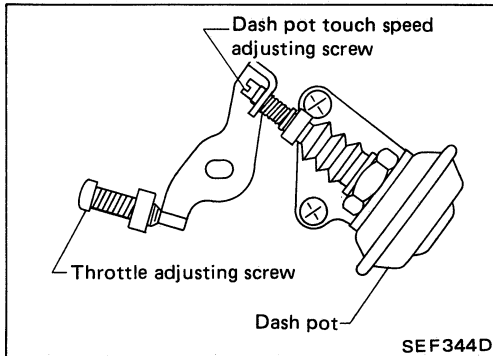

## Dash Pot Inspection and Adjustment

- The idle speed of the engine must be well tuned, and the engine warmed up to normal operation.
- Turn the throttle valve by hand, and read the engine speed when the dash pot just touches the adjusting screw.

### Dash pot touch speed:

VG30i: M/T	1,600 - 1,800 rpm
A/T	2,000 - 2,200 rpm
Z24i:	2,700 - 3,300 rpm

- If out of the specification, adjust it by turning the adjusting screw. (VG30i)
    - Adjustment for dash pot of Z24i is as shown below. (Z24i)
- Turn the adjusting screw until it touches the dash pot.  
**Throttle valve must be closed.**
  - Then turn the adjusting screw 4 more turns.

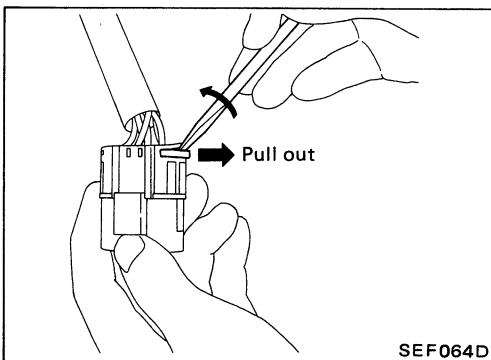

## How To Disassemble Harness Connector (Type W)

- Remove the terminal retainer.

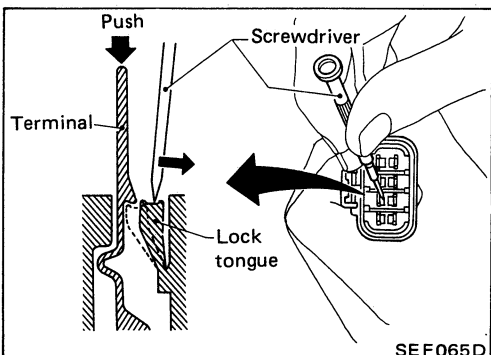

- With a small screwdriver, tilt the lock tongue and, at the same time, push out the terminal.

### CAUTION:

- When extracting terminal, do not pull wire harness. Always push the tip of terminal.
- Take care not to damage seal boot at the bottom of terminal.
- Do not let oil or gasoline contaminate seal boot.

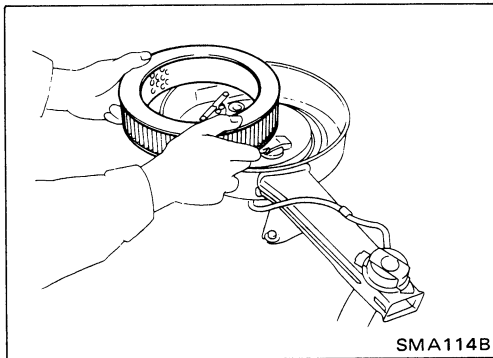

## Inspection

### AIR CLEANER FILTER (Viscous paper type)

Viscous paper type air cleaner filter does not require any cleaning operation until it is replaced periodically. Brushing or blasting operation should never be conducted, because it causes clogging and results in enrichment of the mixture ratio.

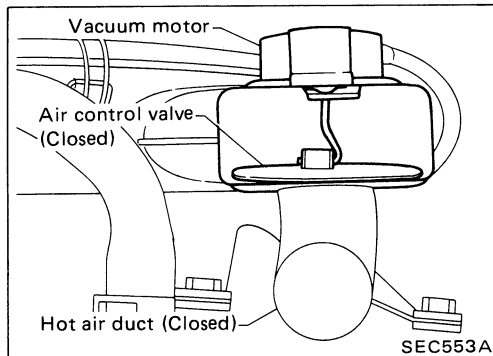

## AUTOMATIC TEMPERATURE CONTROL SYSTEM

- Engine stall or hesitation
- Increase in fuel consumption
- Lack of power

If these phenomena should occur, check the A.T.C. system before carrying out the inspection of the electro injection unit.

1. Check the hoses for cracks, distortion and improper position.
2. Check A.T.C. system for proper function, while the engine is cool. Check the air control valve position.

The air control valve is correct if it is in lower position.

3. Start the engine and immediately check the air control valve position. If it rises, it is correct.
4. Make sure that the air control valve moves up and down when the engine speed is quickly increased and decreased.
5. Make sure that the air control valve partially rises when the engine warm-up advances.

If the above test reveals any problem in the operation of air control valve, carry out the following test:

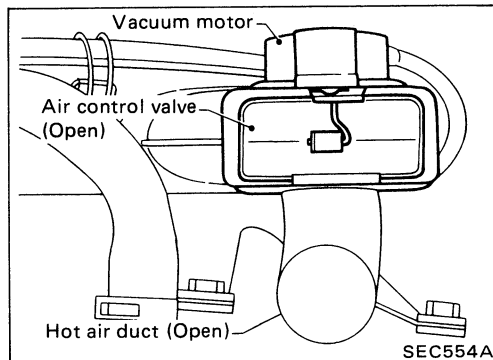

## VACUUM MOTOR

Disconnect the inlet vacuum hose of the vacuum motor, and connect another hose to the inlet to apply vacuum to the vacuum motor. Then, confirm that the air control valve moves.

### Air control valve operating vacuum:

kPa (mmHg, inHg)

Opening starts

−10.0 (−75, −2.95)

Full opening

Over −22.0 (−165, −6.50)

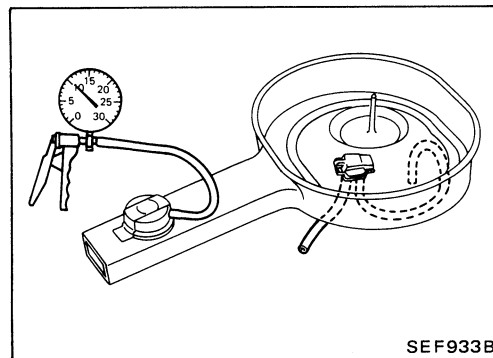

## TEMPERATURE SENSOR

While the engine is cool and idling, disconnect the inlet vacuum hose of the vacuum motor and make sure that intake manifold vacuum is present at the end of the vacuum hose. If vacuum is weak or is not present at all, check the vacuum hose for leakage. Replace the temperature sensor if the vacuum hoses are in good order. And after the engine warms up, make sure that no vacuum is present there. If any, replace the temperature sensor.

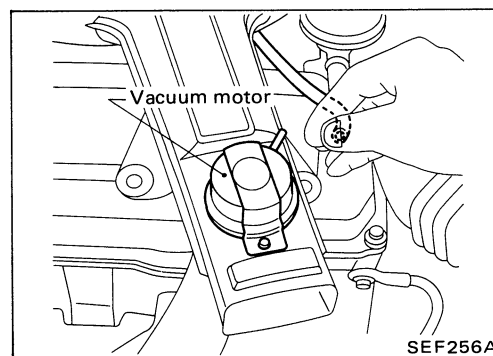

# EXHAUST SYSTEM

## CAUTION:

- a. Be careful not to drop or damage catalytic converter.
- b. Never wet catalytic converter with water, oil, etc.
- After installation, make sure that mounting brackets and mounting insulators are free from undue stress. If any of above parts is not installed properly, excessive noises or vibrations may be transmitted to vehicle body.
- Check all tube connections for exhaust gas leaks, and entire system for unusual noises, with engine running.

### Z24i model (2WD) for Truck

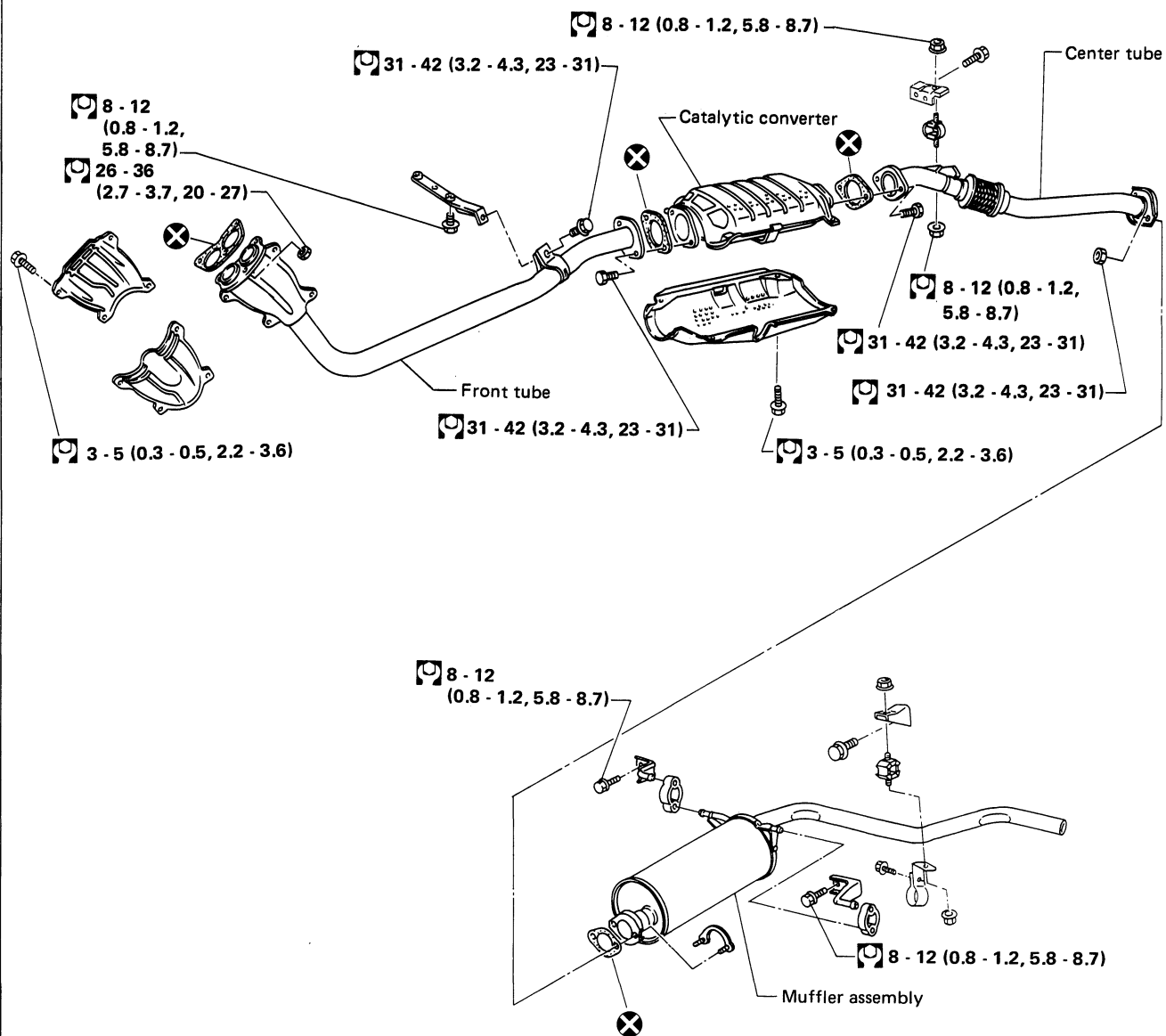

: N-m (kg-m, ft-lb)

SFE004A

# HYDRAULIC CLUTCH CONTROL

## Clutch Master Cylinder (Cont'd)

### INSPECTION

- Check cylinder and piston rubbing surface for uneven wear, rust or damage. Replace if necessary.
- Check piston with piston cup for wear or damage. Replace if necessary.
- Check return spring for wear or damage. Replace if necessary.
- Check reservoir for deformation or damage. Replace if necessary.
- Check dust cover for cracks, deformation or damage. Replace if necessary.

## Operating Cylinder

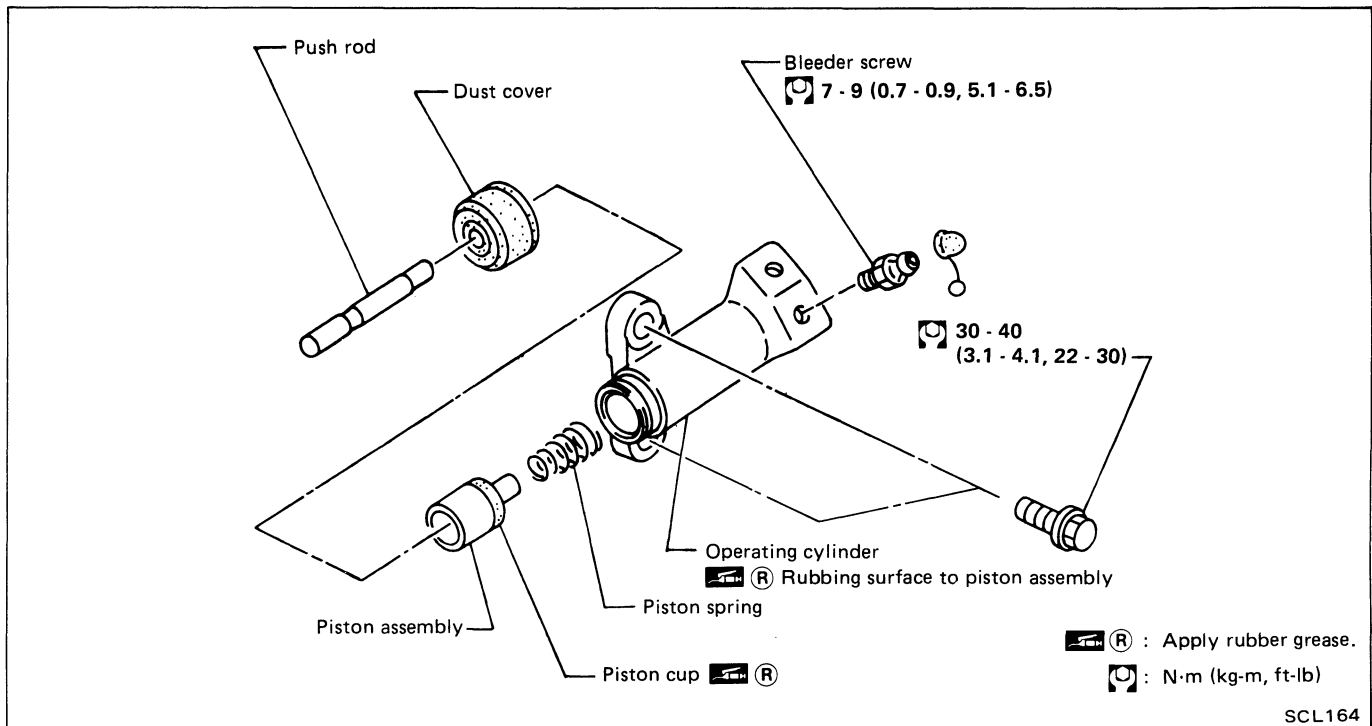

### INSPECTION

- Check rubbing surface of cylinder for wear, rust or damage. Replace if necessary.
- Check piston with piston cup for wear or damage. Replace if necessary.
- Check piston spring for wear or damage. Replace if necessary.
- Check dust cover for cracks, deformation or damage. Replace if necessary.

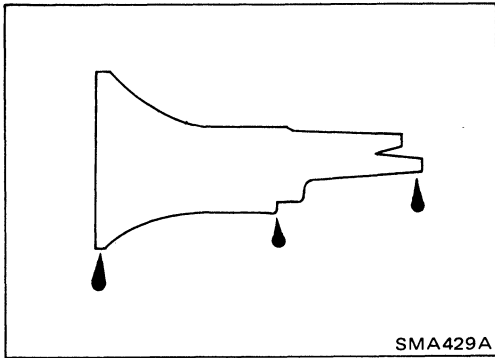

### Checking M/T Oil

- Check manual transmission for oil leakage.

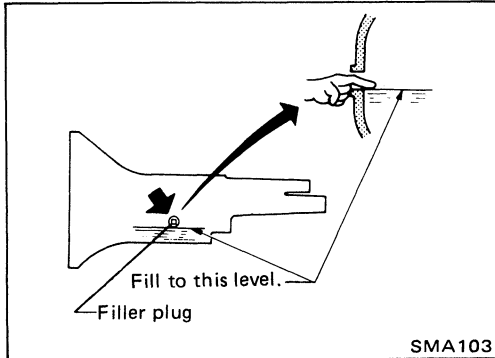

- Check oil level.

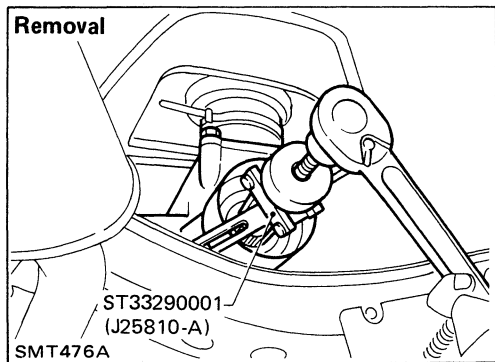

### Replacing Rear Oil Seal — 2WD Model

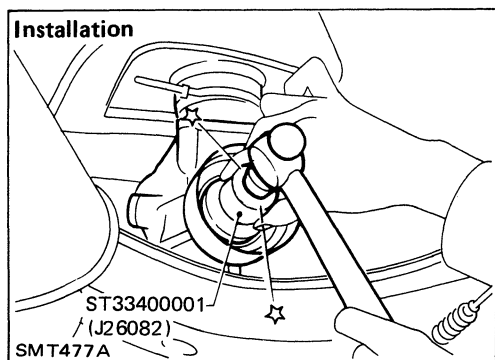

## Gear Components (Cont'd)

- g. Draw out mainshaft assembly by tapping rear end of mainshaft.

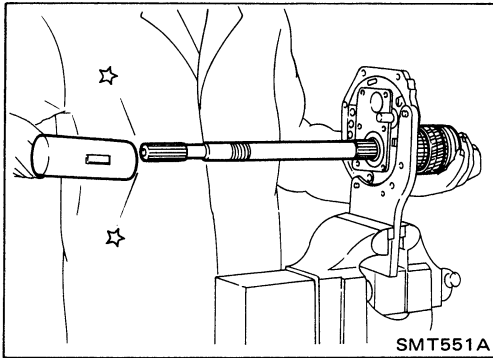

7. Remove thrust washer, steel ball, 1st main gear and needle bearing.

**Be careful not to lose steel ball.**

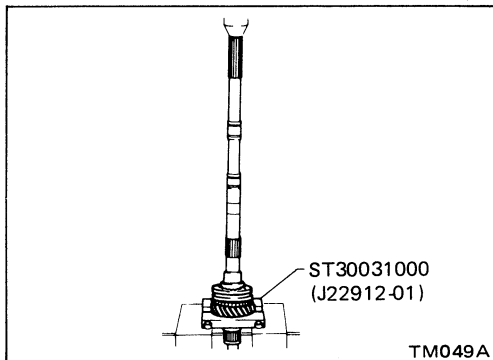

8. Press out 1st gear mainshaft bushing together with 2nd main gear with Tool.  
Then remove 2nd gear needle bearing.

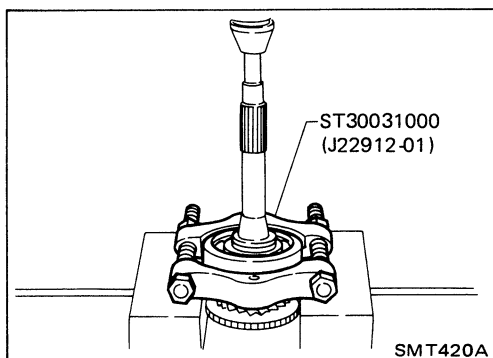

9. Remove main drive gear bearing.  
a. Remove snap ring and washer.  
b. Remove main drive gear bearing.

## Case Components (Cont'd)

7. Select counter front bearing shim.

Unit: mm (in)

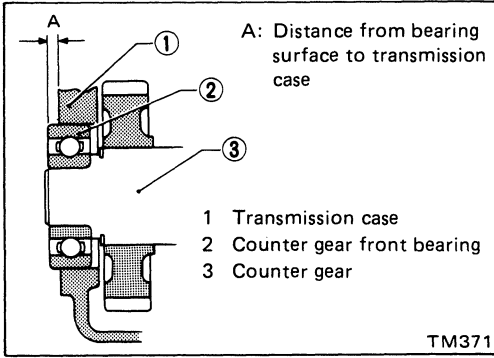

"A"	Thickness of shim	Part number
4.52 - 4.71 (0.1780 - 0.1854)	Not necessary	
4.42 - 4.51 (0.1740 - 0.1776)	0.1 (0.004)	32218-V5000
4.32 - 4.41 (0.1701 - 0.1736)	0.2 (0.008)	32218-V5001
4.22 - 4.31 (0.1661 - 0.1697)	0.3 (0.012)	32218-V5002
4.12 - 4.21 (0.1622 - 0.1657)	0.4 (0.016)	32218-V5003
4.02 - 4.11 (0.1583 - 0.1618)	0.5 (0.020)	32218-V5004
3.92 - 4.01 (0.1543 - 0.1579)	0.6 (0.024)	32218-V5005

8. Install gasket and front cover.

9. Install return spring plugs, check ball, return springs and select check plunger.

10. Install control housing and gasket.

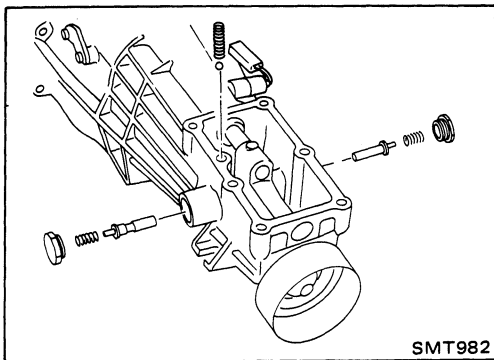

**Gear Components (Cont'd)**

- Measure wear of reverse baulk ring.
  - a. Place baulk ring in position on reverse cone.
  - b. While holding baulk ring against reverse cone as far as it will go, measure dimension "A" with dial indicator.

Unit: mm (in)

	Standard	Wear limit
Dimension "A"	-0.1 to 0.35 (-0.0039 to 0.0138)	0.7 (0.028)

- c. If dimension "A" is larger than the wear limit, replace baulk ring.

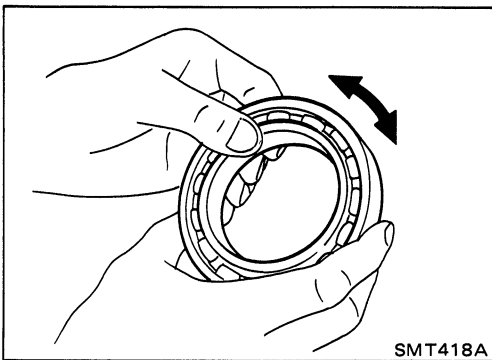
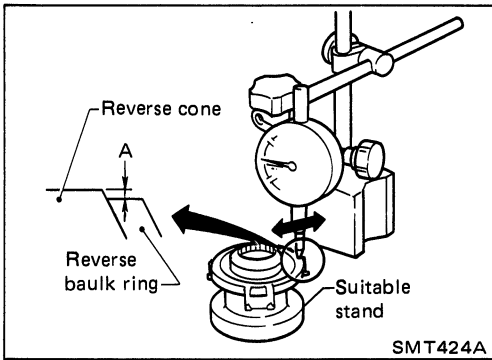

**BEARINGS**

- Make sure bearings roll freely and are free from noise, crack, pitting or wear.

# SERVICE DATA AND SPECIFICATIONS (S.D.S.)

## General Specifications

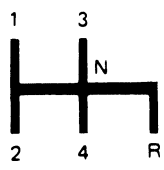
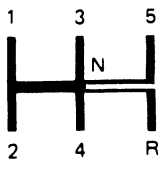
Vehicle model	2WD		4WD		2WD	4WD
Transmission model	F4W71C		FS5W71C		FS5R30A	
Engine	Z24i				VG30i	
No. of speeds	4		5			
Shift pattern						
Synchromesh type	Warner					
Gear ratio						
1st	3.321	3.321	3.592	3.985	3.580	4.061
2nd	1.902	1.902	2.246	2.246	2.077	2.357
3rd	1.308	1.308	1.415	1.415	1.360	1.490
4th	1.000	1.000	1.000	1.000	1.000	1.000
O.D.	—	0.838	0.821	0.821	0.811	0.862
Reverse	3.382	3.382	3.657	3.657	3.636	4.125
No. of teeth						
Mainshaft						
Drive	22	22	21	21	22	20
1st	33	33	33	34	32	32
2nd	27	27	28	28	30	30
3rd	26	26	26	26	29	28
O.D.	—	22	21	21	24	23
Reverse	36	36	36	36	30	30
Countershaft						
Drive	31	31	32	32	32	33
1st	14	14	14	13	13	13
2nd	20	20	19	19	21	21
3rd	28	28	28	28	31	31
O.D.	—	37	39	39	43	44
Reverse	15	15	15	15	12	12
Reverse idler gear	21	21	21	21	22	22
Oil capacity ℓ (US pt, Imp pt)	1.7 (3-5/8, 3)	2.0 (4-1/4, 3-1/2)	4.0 (8-1/2, 7)		2.4 (5-1/8, 4-1/4)	3.6 (7-5/8, 6-3/8)

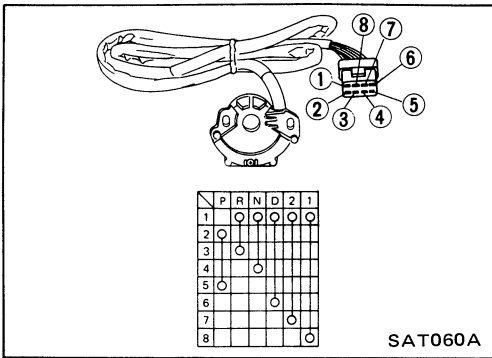

### Inhibitor Switch Adjustment

Disconnect harness at connector, then remove inhibitor switch.

- Check continuity at each range.
- With selector lever held in "Neutral", turn manual lever an equal amount in both directions to see if current flow ranges are nearly the same. (Current normally begins to flow before manual lever reaches a angle of 1.5° in either direction.)  
If current flows outside normal range, or if normal flow range is out of specifications, properly adjust inhibitor switch.

Adjust inhibitor switch as follows:

1. Place the manual valve in Neutral (vertical position).
2. Remove the screw.

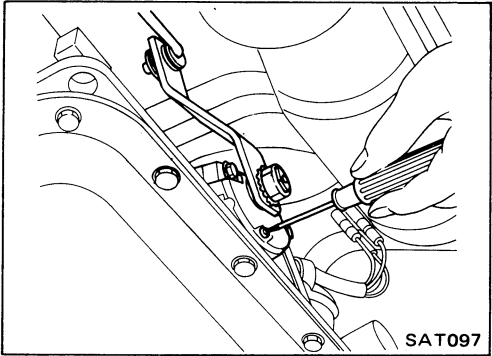

3. Loosen the attaching bolts.
4. With an aligning pin [2.0 mm (0.079 in) dia.], move the switch until the pin falls into the hole in the rotor.
5. Tighten the attaching bolts equally.
6. Recheck for continuity. If necessary, replace the switch.

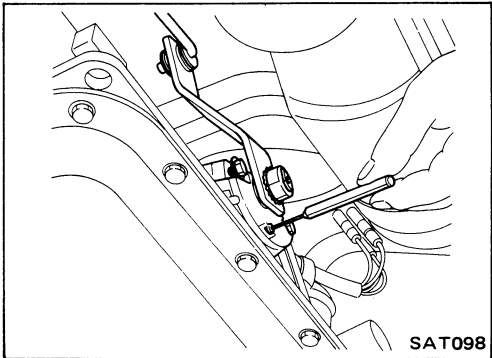

### Manual Linkage Adjustment (Floor shift models)

Move the selector lever from the "P" range to "1" range. You should be able to feel the detents in each range.

If the detents cannot be felt or the pointer indicating the range is improperly aligned, the linkage needs adjustment.

1. Place selector lever in "P" range.
2. Loosen lock nuts.
3. Tighten lock nut (X) until it touches trunnion, pulling selector lever toward "R" range side without pushing button.
4. Back off lock nut (X) 1 turn and tighten lock nut (Y) to the specified torque.  
 : Lock nut  
 11 - 15 N·m (1.1 - 1.5 kg·m, 8 - 11 ft·lb)
5. Move selector lever from "P" range to "1" range. Make sure that selector lever can move smoothly.

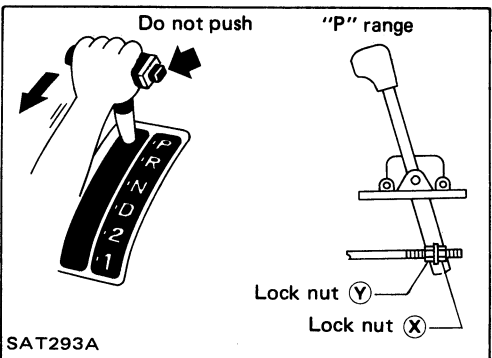
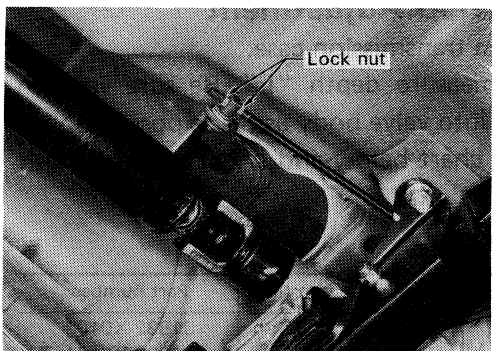

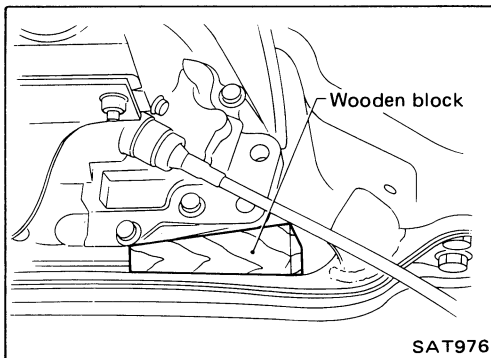
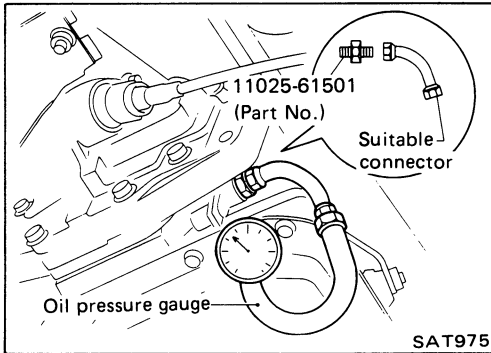
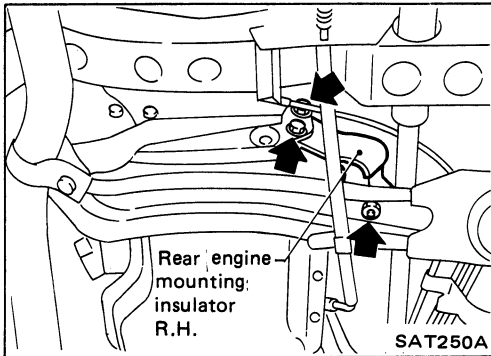
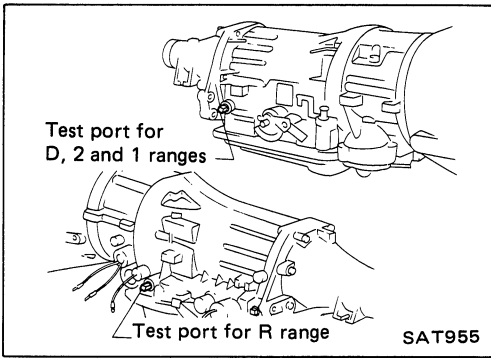

## Pressure Testing

- Location of line pressure test port.

1. Install pressure gauge to line pressure port.
  - (1) Support transmission with a jack.
  - (2) Remove rear engine mounting insulator R.H.

- (3) Remove line pressure plug and install oil pressure gauge and adapters.

- (4) Place a suitably sized wooden block between the transmission and rear engine mounting bracket.

2. Warm up engine until engine oil and A.T.F. reach operating temperature after vehicle has been driven approx. 10 minutes.

**A.T.F. temperature:**

**50 - 80° C (122 - 176° F)**

3. Set parking brake and block wheels.
  4. Measure line pressure at idle and stall point while depressing brake pedal fully.
- **When measuring line pressure at stall point, follow the stall test procedure.**

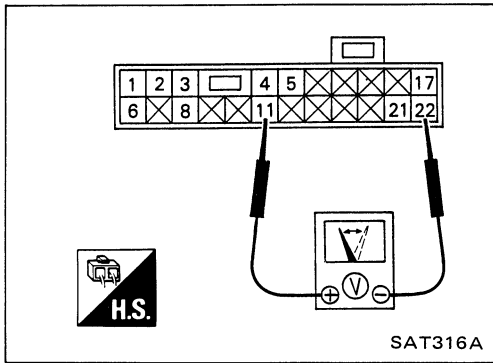

### CHECK ⑤

- Turn ignition switch ON and move vehicle over 1 m (3 ft) at very low speed.  
Voltage must vary from 0V to approx. 5V.

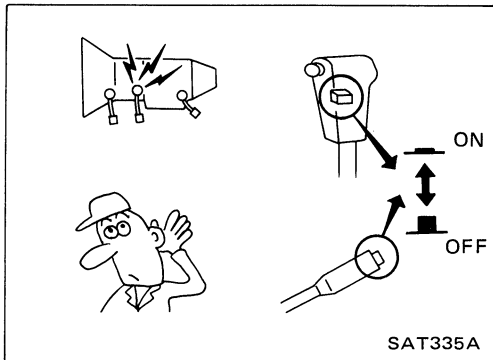

### CHECK ⑥

- Turn ignition switch ON.
- Turn O.D. control switch to "OFF" and "ON" and check to see if O.D. cancel solenoid clicks.

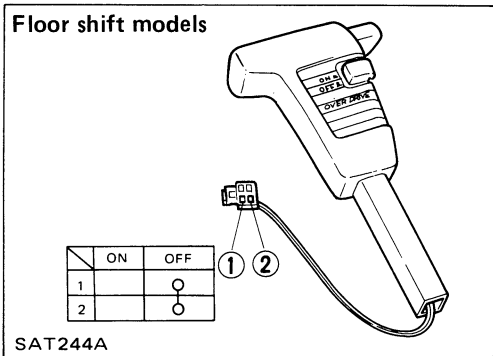

### CHECK ⑧

- Check continuity between terminals.

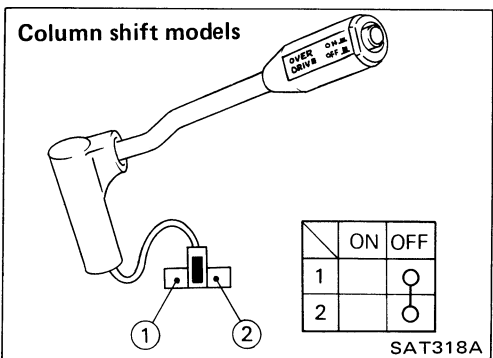

### CHECK ⑩

- Measure voltage while driving vehicle in O.D. gear.  
Accelerator pedal is depressed 3/4 or more → 0V  
Accelerator pedal is released to 1/2 or less after depressing it → Battery voltage

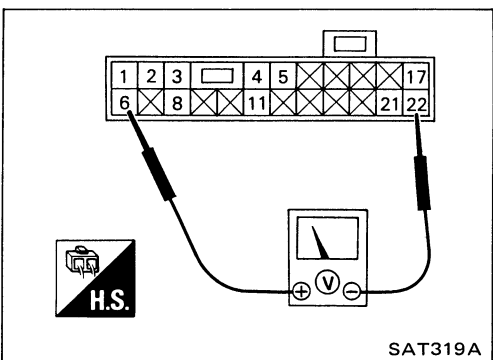

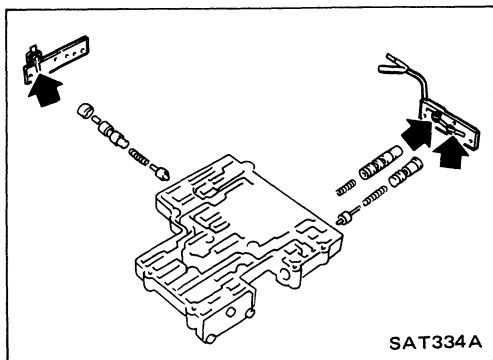

**CHECK ⑧**

- Check contact points of shift switches for damage.

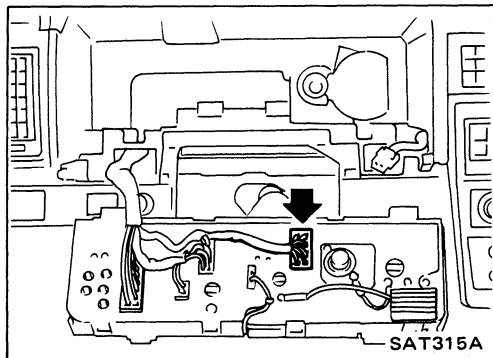

**CHECK ⑨**

- Check connection of vehicle speed sensor connector.
- Check wires between vehicle speed sensor and lock-up control unit.

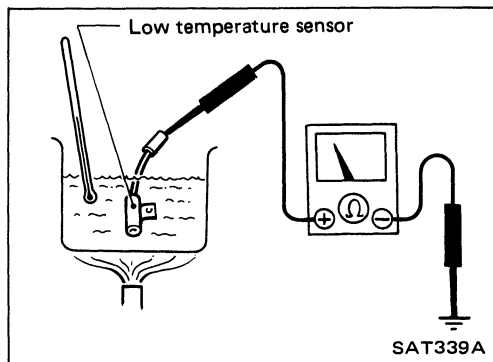

**CHECK ⑩**

- Check continuity on low temperature sensor.  
 45° C (113° F) or more → ∞  
 35° C (95° F) or less → 0Ω

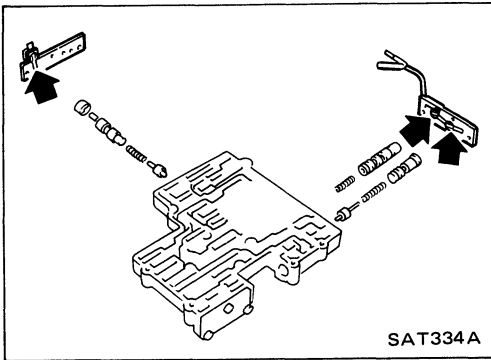

### CHECK (h)

- Check contact points of shift switches for damage.

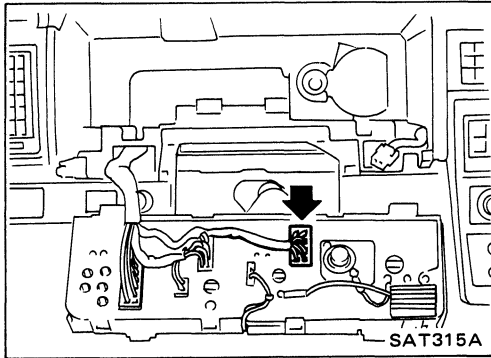

### CHECK (i)

- Check connection of vehicle speed sensor connector.
- Check wires between vehicle speed sensor and lock-up control unit.

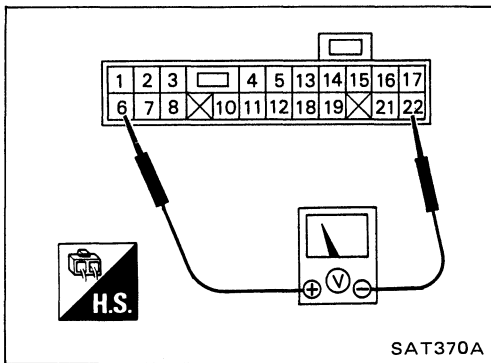

### CHECK (j)

- Turn power shift switch to "AUTO" and measure voltage while driving vehicle in "D" range.  
**60 km/h (37 MPH) or more with light load → Approx. 0V**  
**Vehicle is at standstill → Battery voltage**

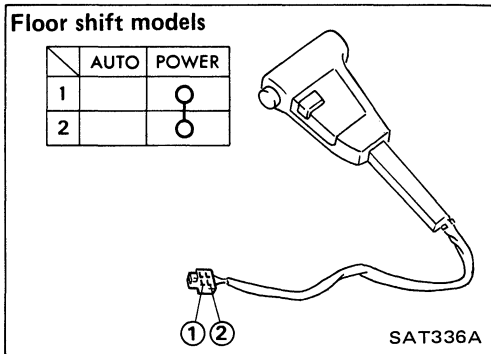

### CHECK (k)

- Check continuity between terminals.

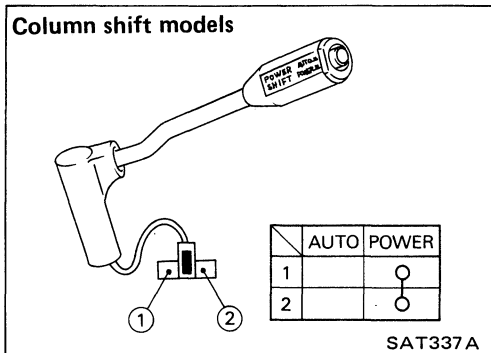

L4N71B and E4N71B

Ⓢ : N·m (kg-m, ft-lb)

- Ⓐ 39 - 49 (4.0 - 5.0, 29 - 36)
- Ⓑ 10 - 15 (1.0 - 1.5, 7 - 11)
- Ⓒ 44 - 54 (4.5 - 5.5, 33 - 40)
- Ⓓ 13 - 18 (1.3 - 1.8, 9 - 13)
- Ⓔ 5 - 7 (0.5 - 0.7, 3.6 - 5.1)
- Ⓕ 8 - 11 (0.8 - 1.1, 5.8 - 8.0)
- Ⓖ 7 - 9 (0.7 - 0.9, 5.1 - 6.5)
- Ⓗ 5.4 - 7.4 (0.55 - 0.75, 4.0 - 5.4)
- Ⓙ 5 - 7 (0.5 - 0.7, 3.6 - 5.1)
- Ⓚ 29 - 39 (3.0 - 4.0, 22 - 29)

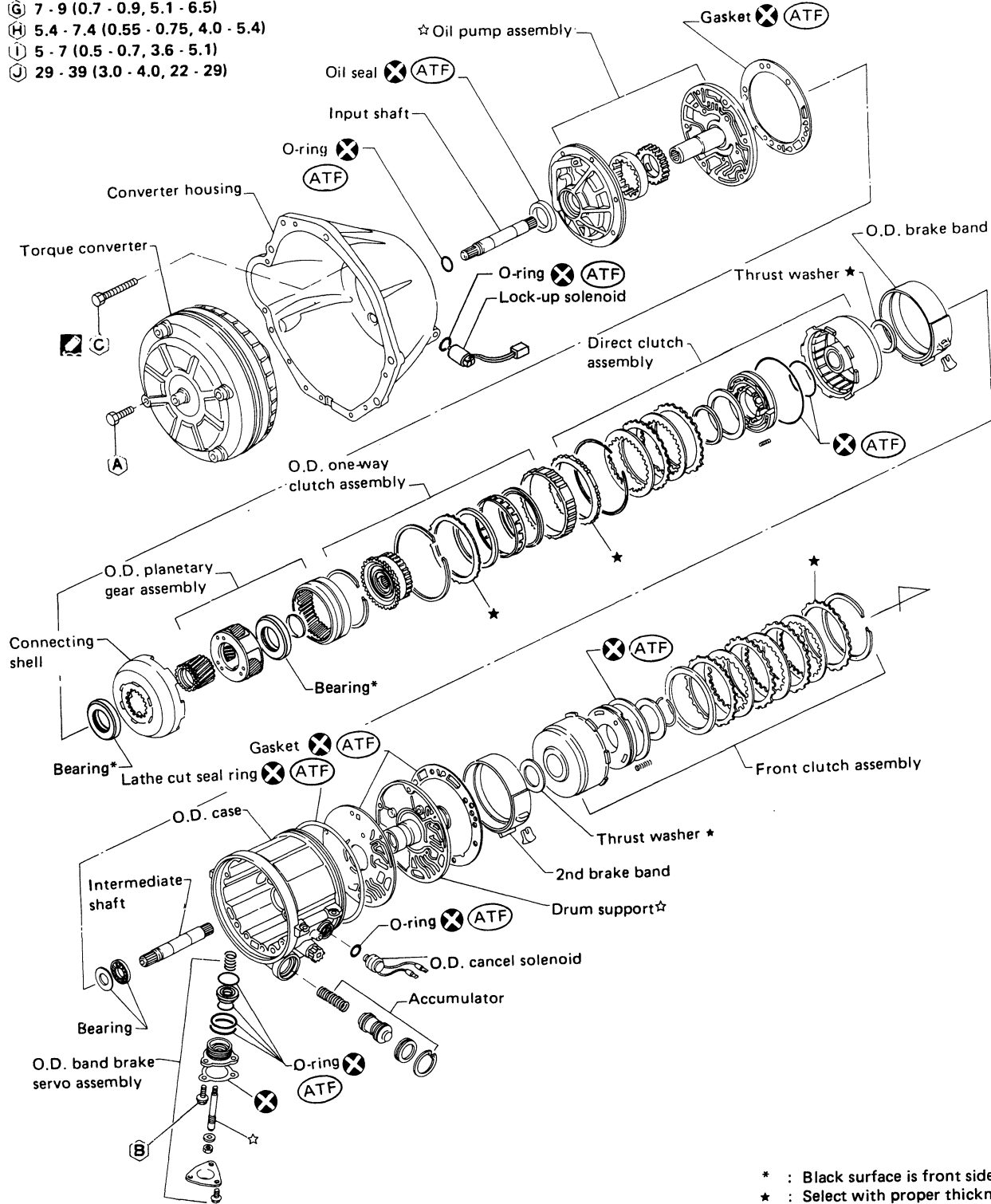

\* : Black surface is front side.  
 ★ : Select with proper thickness.  
 ☆ : Adjustment is required.

Ⓢ : Apply A.T.F.

**Oil Pump (Cont'd)**

**INSPECTION**

1. Inspect pump body, bushing and pump shaft, for wear.
2. Inspect gears, lockup control valve, spring and all internal surfaces for damage and visible wear.

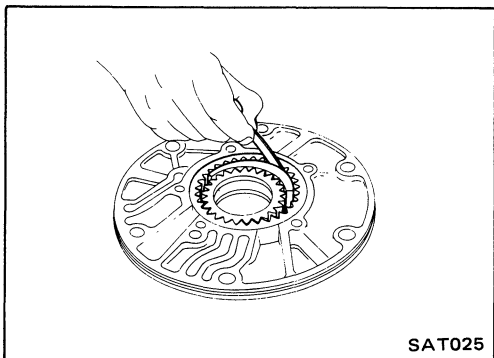

3. Measure clearance between outer gear and crescent.
  - Standard clearance:**  
0.14 - 0.21 mm (0.0055 - 0.0083 in)
  - Wear limit:**  
0.25 mm (0.0098 in)

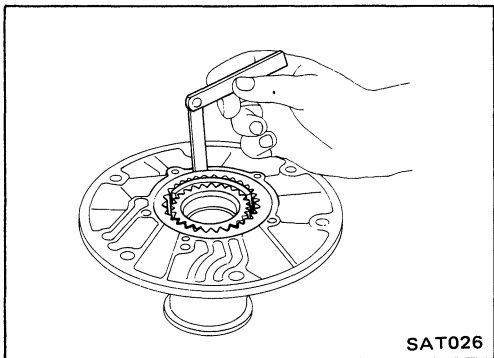

4. Measure clearance between outer gear and pump housing.
  - Standard clearance:**  
0.05 - 0.20 mm (0.0020 - 0.0079 in)
  - Wear limit:**  
0.25 mm (0.0098 in)

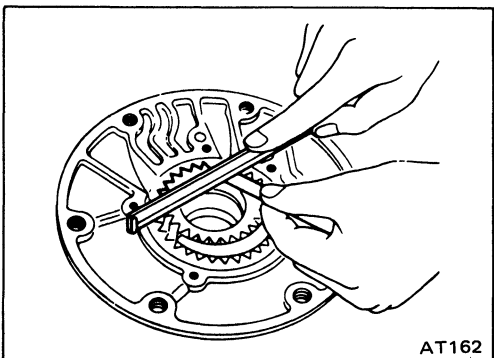

5. Using a feeler gauge and straight edge, measure clearance between gears and pump cover.
  - Standard clearance:**  
0.02 - 0.04 mm (0.0008 - 0.0016 in)
  - Wear limit:**  
0.08 mm (0.0031 in)

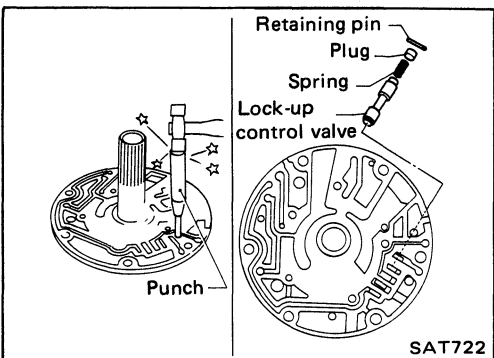

**ASSEMBLY**

1. Install lockup control valve and spring into oil pump cover, then tap new retaining pin.

**Direct Clutch (Cont'd)**

**10. Testing direct clutch**

With direct clutch assembled on drum support, direct a jet of air into hole in clutch drum for definite clutch operation.

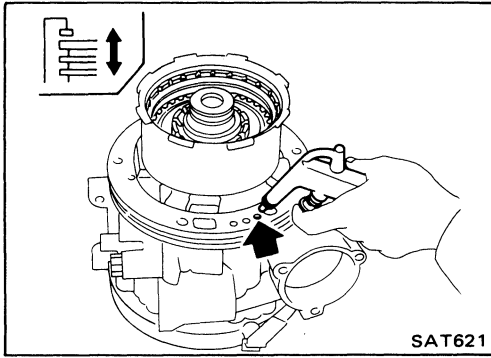

SAT621

**Front Clutch**

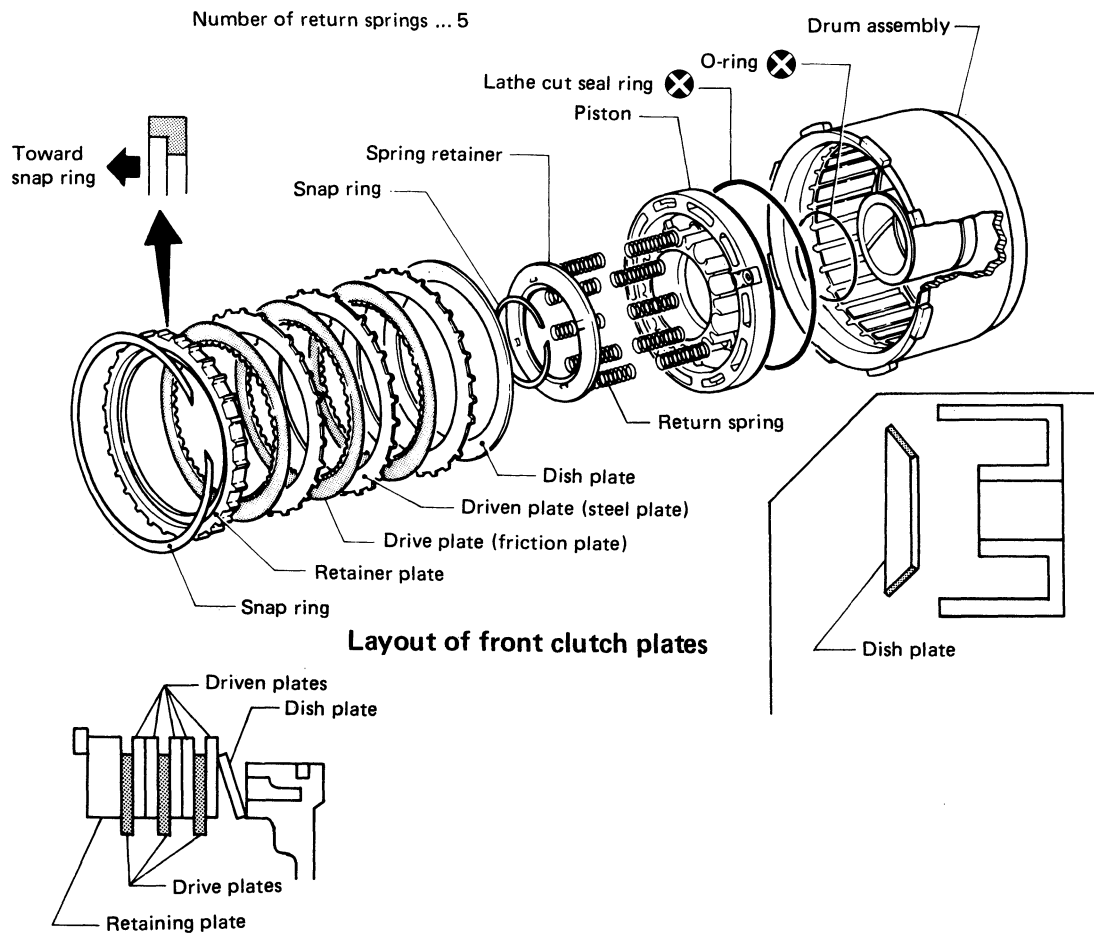

SAT348A

CLICK HERE TO **DOWNLOAD** THE COMPLETE MANUAL

- Thank you very much for reading the preview of the manual.
- You can download the complete manual from: [www.heydownloads.com](http://www.heydownloads.com) by clicking the link below



- Please note: If there is no response to CLICKING the link, please download this PDF first and then click on it.

CLICK HERE TO **DOWNLOAD** THE COMPLETE MANUAL

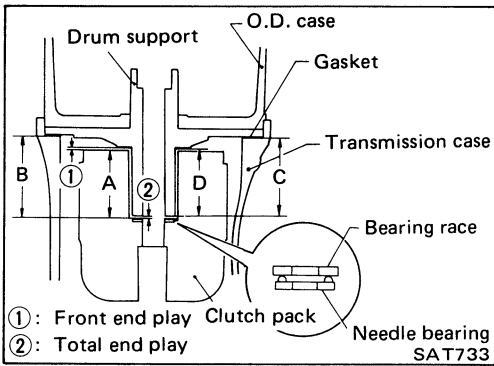

16. Adjust end play as follows:

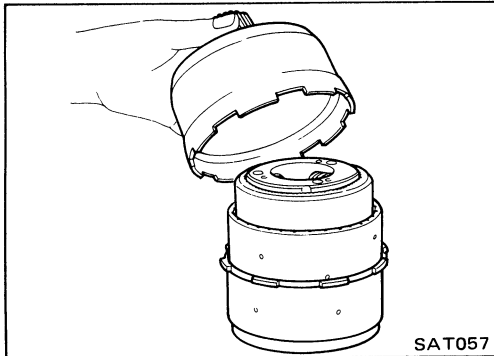

1) Assemble front internal gear, front planetary carrier and connecting shell. Secure thrust bearings with vaseline.

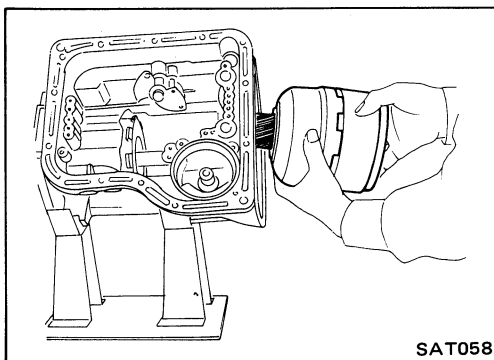

2) Install assembly into transmission case. Check that parts are properly seated before proceeding with measurements.

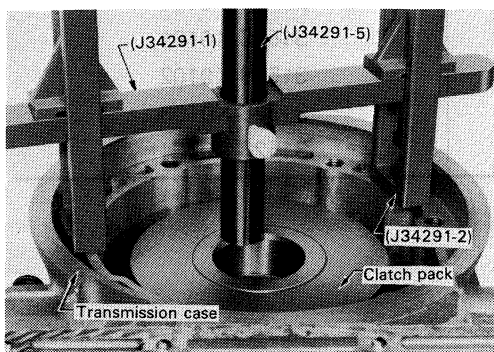

3) Adjust front end play.

a. Place J34291-1 (bridge), J34291-2 (legs) and J34291-5 (gauging cylinder) on machined surface of transmission case (no gasket): Position bridge legs so short end of legs is down, and adjust the legs to fit onto case properly. Allow the gauging cylinder to rest on top of thrust washer surface of clutch pack. Now lock gauging cylinder in position with thumbscrew.

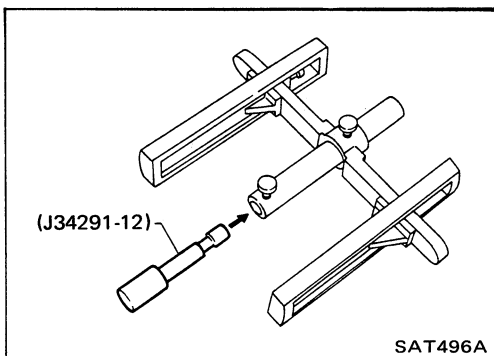

b. Remove thrust washer from drum support.

c. Now insert J34291-12 (gauging plunger) into gauging cylinder.

Lock gauging plunger by tightening the thumbscrew.

Hydraulic Control Circuits

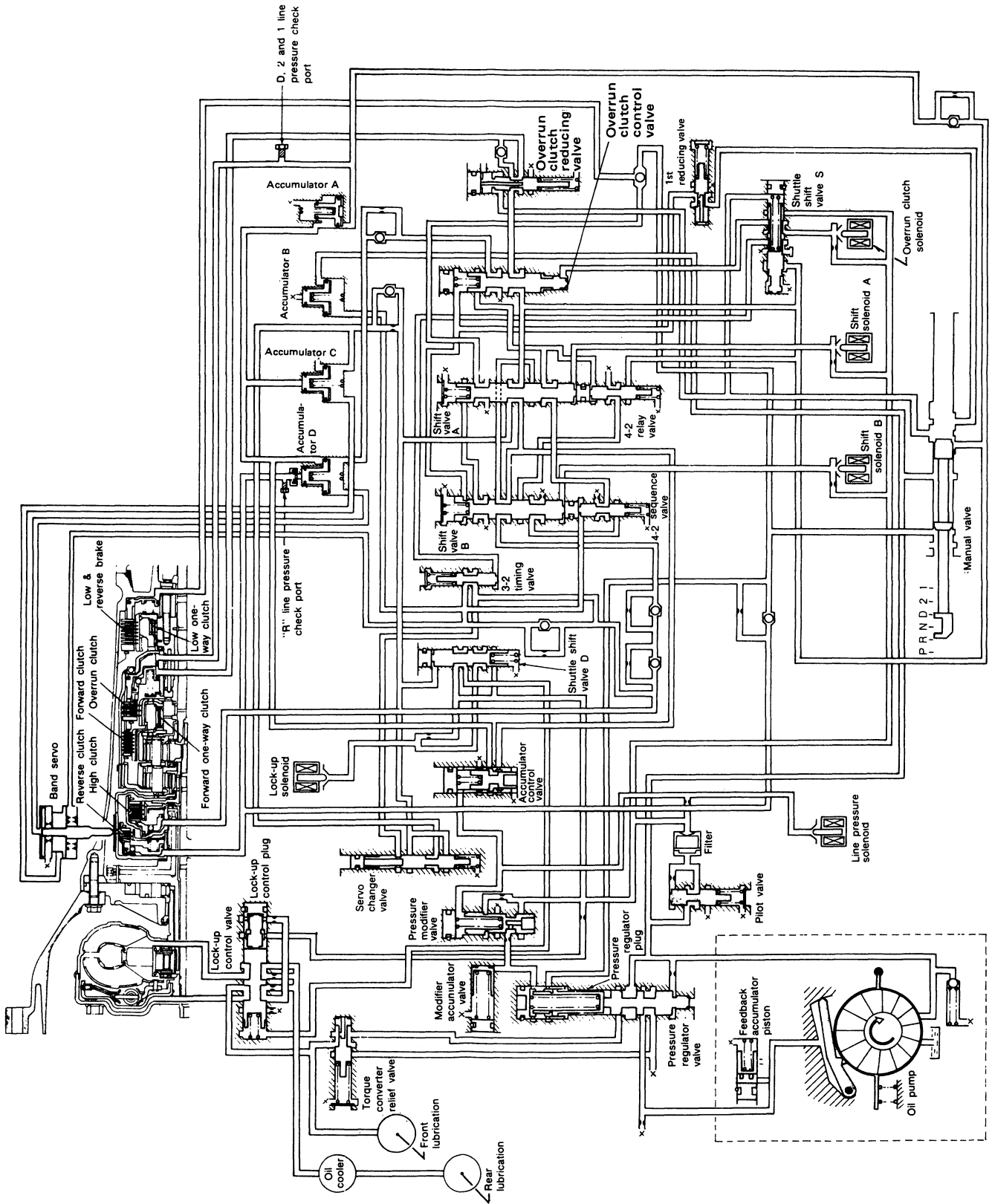

Road Testing (Cont'd)

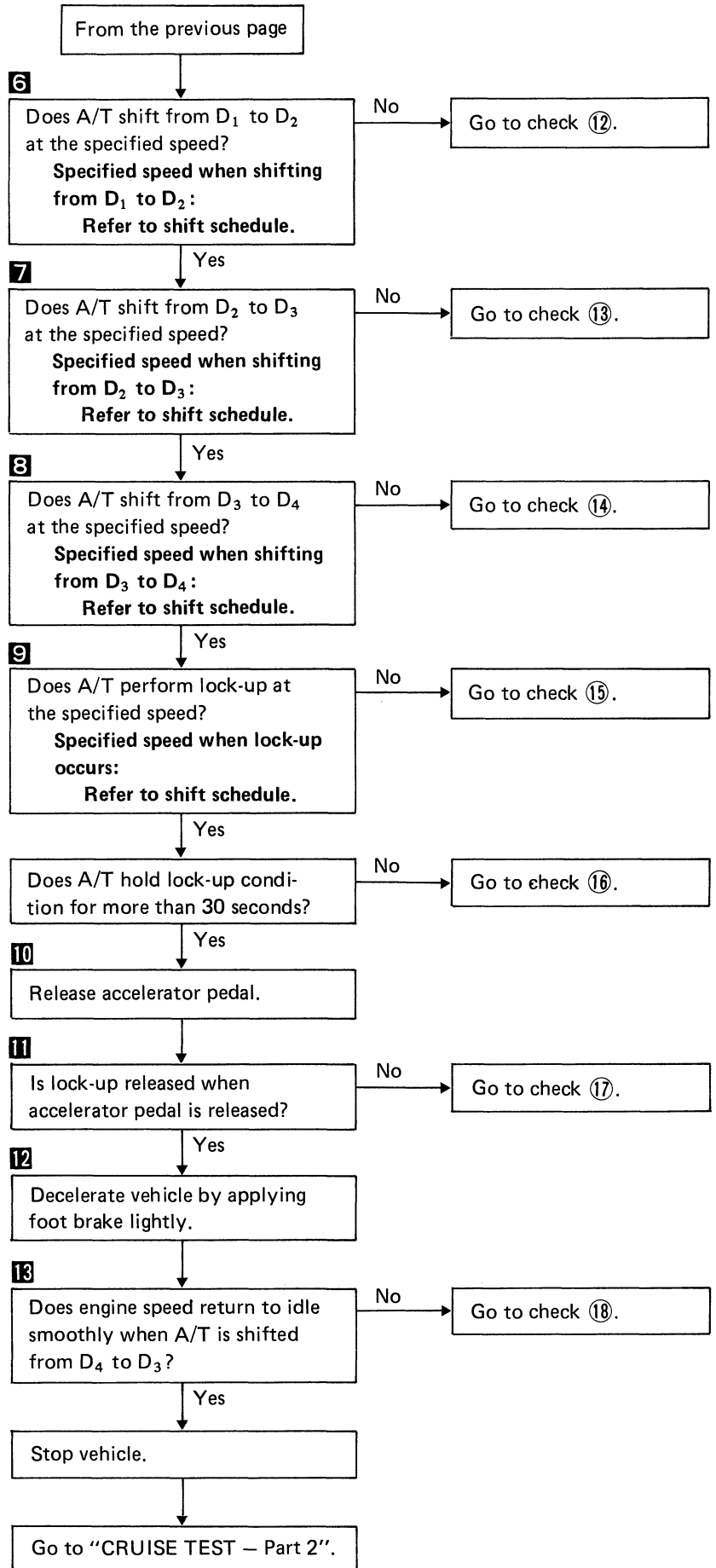
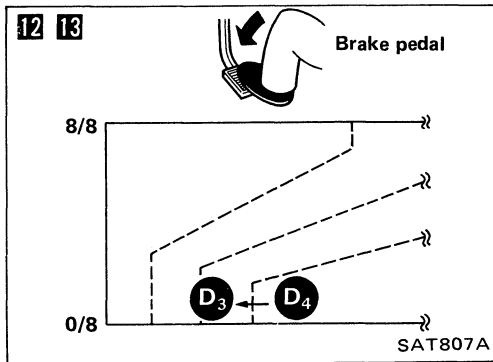
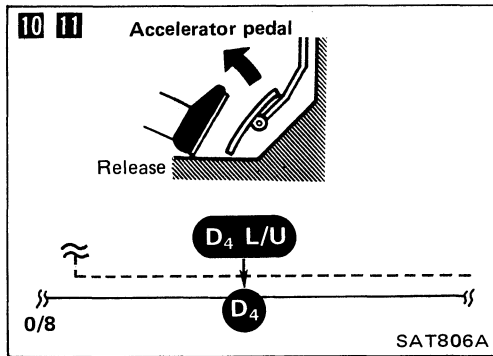
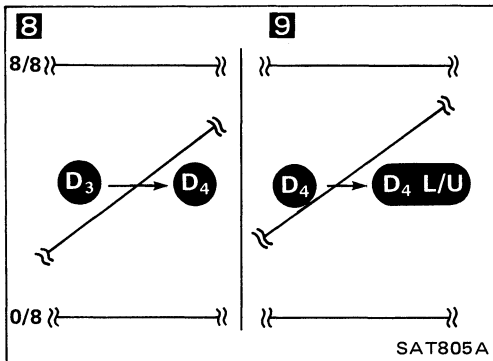
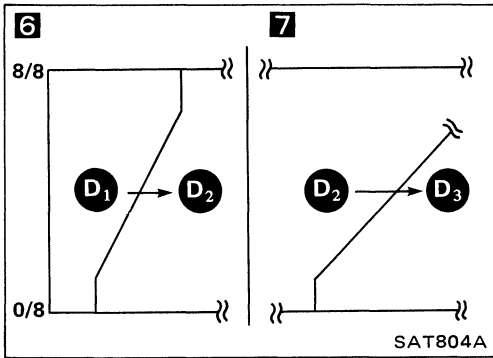

Trouble-shooting — Self-diagnosis (Cont'd)

SHIFT SOLENOID B CIRCUIT CHECK

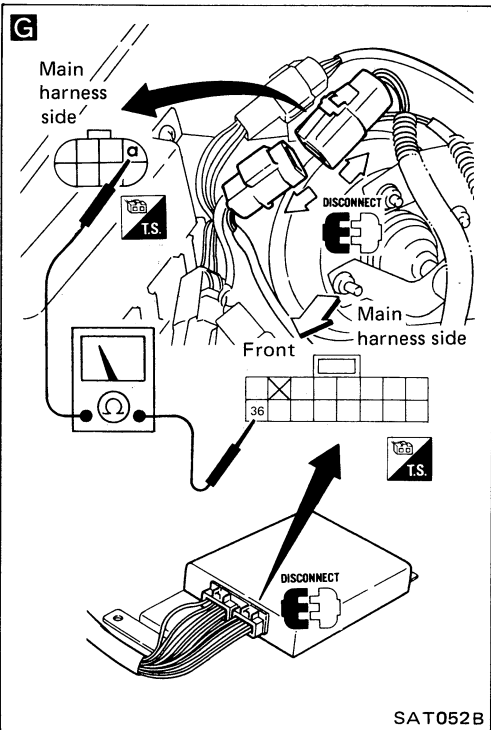
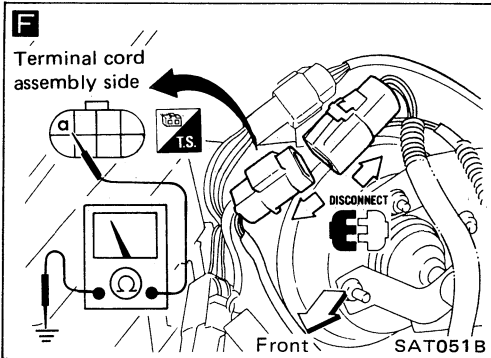
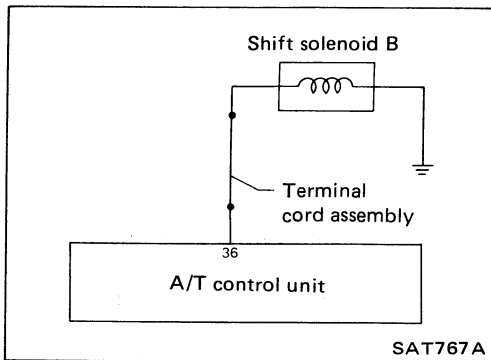

**F**

**CHECK GROUND CIRCUIT**

- 1.
2. Disconnect terminal cord assembly connector in engine compartment.
3. Check resistance between terminal ③ and ground.  
**Resistance: 20 - 30Ω**

N.G.

1. Remove control valve assembly. — Refer to "ON-VEHICLE SERVICE".
2. Check the following items.
  - Shift solenoid B — Refer to "Electrical System".
  - Harness continuity of terminal cord assembly

O.K.

**G**

**CHECK POWER SOURCE CIRCUIT**

- 1.
2. Disconnect A/T control unit 16-pin connector.
3. Check resistance between terminal ③ and A/T control unit terminal ③⑥.  
**Resistance: Approximately 0Ω**
4. Reinstall any part removed.

N.G.

Repair or replace harness between A/T control unit and terminal cord assembly. (Main harness)

O.K.

Perform self-diagnosis after driving for a while.

O.K.

**INSPECTION END**

N.G.

1. Perform A/T control unit input/output signal inspection.
2. If N.G., recheck A/T control unit pin terminals for damage or connection of A/T control unit harness connector.

**Trouble-shooting (Cont'd)**

**CHECK ⑧ : Vehicle does not creep backward when selecting "R" range.**

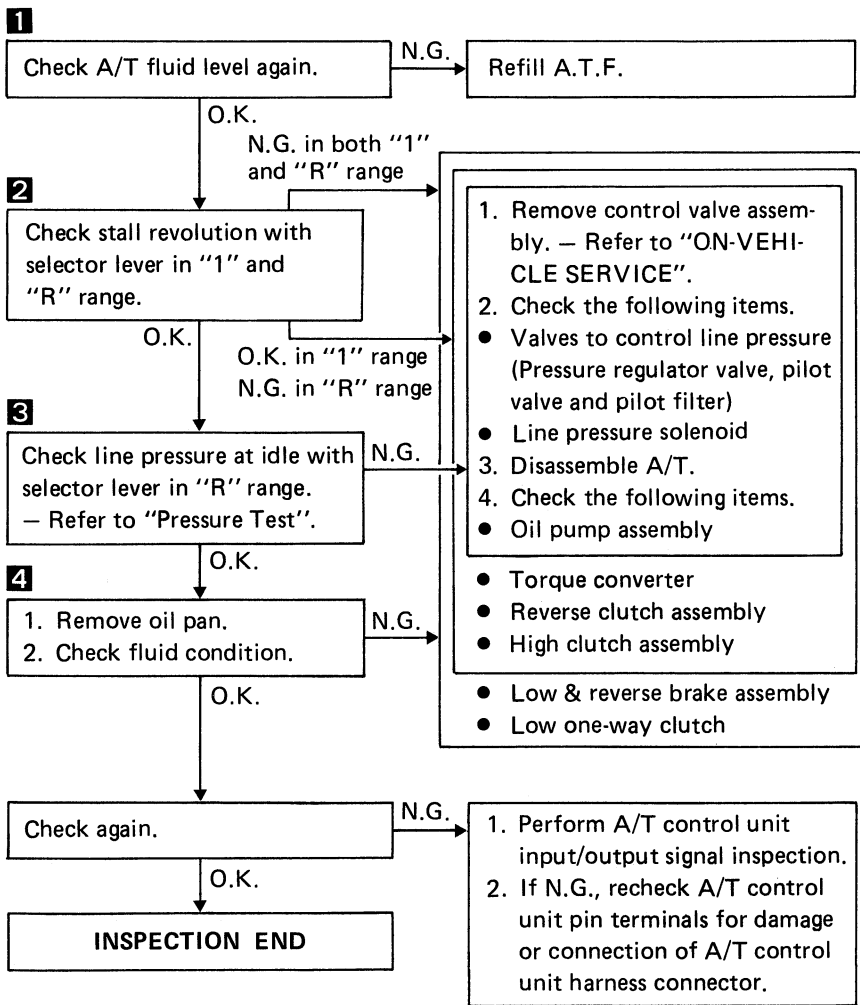
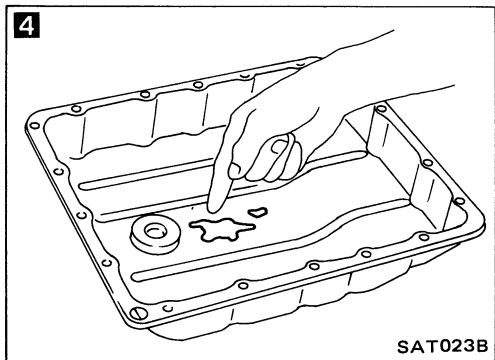
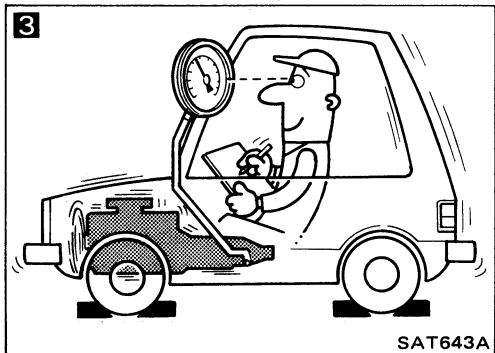
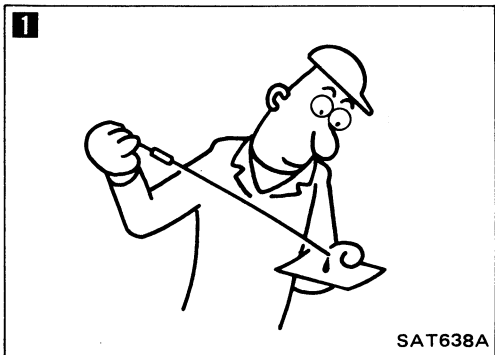

Electrical System (Cont'd)  
SCHEMATIC

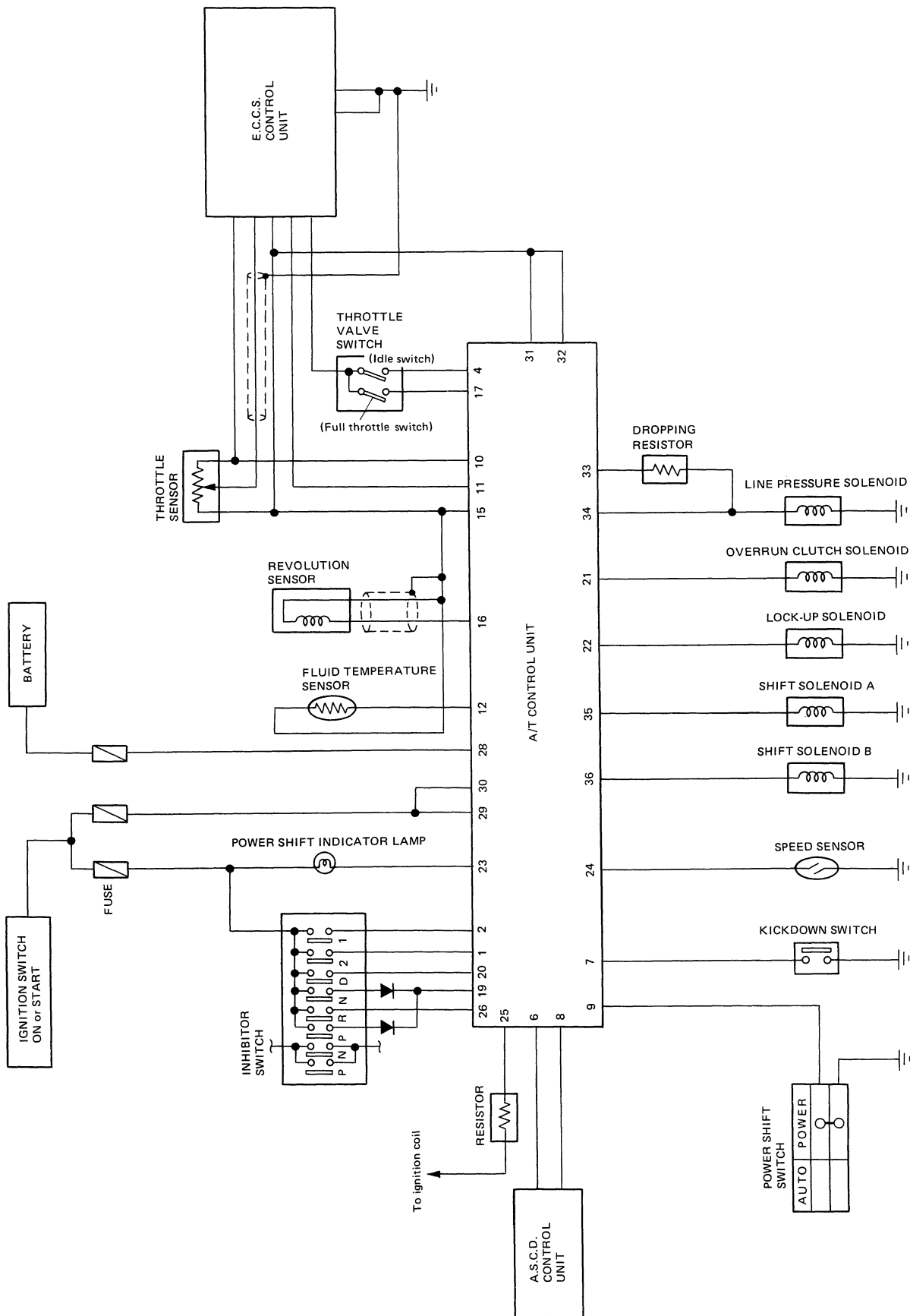

Trouble-shooting Chart (Cont'd)

Numbers are arranged in order of probability. Perform inspections starting with number one and working up. Circled numbers indicate that the transmission must be removed from the vehicle.

	ON vehicle													OFF vehicle																
	Fluid level	Control linkage	Inhibitor switch	Throttle sensor (Adjustment)	Revolution sensor and speed sensor	Engine revolution signal	Engine idling rpm	Line pressure	Control valve assembly	Shift solenoid A	Shift solenoid B	Line pressure solenoid	Lock-up solenoid	Overrun clutch solenoid	Fluid temperature sensor	Accumulator N-D	Accumulator 1-2	Accumulator 2-3	Accumulator 3-4 (N-R)	Ignition switch and starter	Torque converter	Oil pump	Reverse clutch	High clutch	Forward clutch	Forward one-way clutch	Overrun clutch	Low one-way clutch	Low & reverse brake	Brake band
Too sharp a shock in change from "D <sub>3</sub> " to "D <sub>4</sub> ".	.	.	.	1	.	.	.	2	4	.	.	.	.	.	.	.	.	3	.	.	.	.	.	.	.	6	.	.	5	.
Almost no shock or clutches slipping in change from "D <sub>1</sub> " to "D <sub>2</sub> ".	1	.	.	2	.	.	.	3	5	.	.	.	.	.	.	.	4	.	.	.	.	.	.	.	.	.	.	.	6	.
Almost no shock or slipping in change from "D <sub>2</sub> " to "D <sub>3</sub> ".	1	.	.	2	.	.	.	3	5	.	.	.	.	.	.	.	4	.	.	.	.	.	.	6	.	.	.	.	7	.
Almost no shock or slipping in change from "D <sub>3</sub> " to "D <sub>4</sub> ".	1	.	.	2	.	.	.	3	5	.	.	.	.	.	.	.	4	.	.	.	.	.	.	6	.	.	.	.	7	.
Vehicle braked by gear change from "D <sub>1</sub> " to "D <sub>2</sub> ".	1	.	.	.	.	.	.	.	.	.	.	.	.	.	.	.	.	.	.	.	.	.	2	4	.	.	.	5	3	.
Vehicle braked by gear change from "D <sub>2</sub> " to "D <sub>3</sub> ".	1	.	.	.	.	.	.	.	.	.	.	.	.	.	.	.	.	.	.	.	.	.	.	.	.	.	.	.	2	.
Vehicle braked by gear change from "D <sub>3</sub> " to "D <sub>4</sub> ".	1	.	.	.	.	.	.	.	.	.	.	.	.	.	.	.	.	.	.	.	.	.	4	.	.	3	2	.	.	.
Maximum speed not attained. Acceleration poor.	1	.	2	.	.	.	.	.	5	3	4	.	.	.	.	.	.	.	.	.	11	10	6	7	.	.	.	9	8	.
Failure to change gear from "D <sub>4</sub> " to "D <sub>3</sub> ".	1	.	.	2	.	.	.	.	6	4	.	5	.	3	.	.	.	.	.	.	.	.	.	.	.	.	8	7	.	.
Failure to change gear from "D <sub>3</sub> " to "D <sub>2</sub> " or from "D <sub>4</sub> " to "D <sub>1</sub> ".	1	.	.	2	.	.	.	.	5	3	4	.	.	.	.	.	.	.	.	.	.	.	6	.	.	.	.	7	.	.
Failure to change gear from "D <sub>2</sub> " to "D <sub>1</sub> " or from "D <sub>3</sub> " to "D <sub>1</sub> ".	1	.	.	2	.	.	.	.	5	3	4	.	.	.	.	.	.	.	.	.	.	.	7	.	.	.	6	.	8	.
Gear change shock felt during deceleration by releasing accelerator pedal.	.	.	.	1	.	.	.	2	4	.	.	.	3	.	.	.	.	.	.	.	.	.	.	.	.	.	.	.	.	.
Too high a change point from "D <sub>4</sub> " to "D <sub>3</sub> ", from "D <sub>3</sub> " to "D <sub>2</sub> ", from "D <sub>2</sub> " to "D <sub>1</sub> ".	.	.	.	1	2	.	.	.	.	.	.	.	.	.	.	.	.	.	.	.	.	.	.	.	.	.	.	.	.	.
Kickdown does not operate when depressing pedal in "D <sub>4</sub> " within kickdown vehicle speed.	.	.	.	1	2	.	.	.	.	3	4	.	.	.	.	.	.	.	.	.	.	.	.	.	.	.	.	.	.	.
Kickdown operates or engine overruns when depressing pedal in "D <sub>4</sub> " beyond kickdown vehicle speed limit.	.	.	.	2	1	.	.	.	.	3	4	.	.	.	.	.	.	.	.	.	.	.	.	.	.	.	.	.	.	.
Races extremely fast or slips in changing from "D <sub>4</sub> " to "D <sub>3</sub> " when depressing pedal.	1	.	.	2	.	.	.	3	5	.	4	.	.	.	.	.	.	.	.	.	.	.	6	7	.	.	.	.	.	.
Races extremely fast or slips in changing from "D <sub>4</sub> " to "D <sub>2</sub> " when depressing pedal.	1	.	.	2	.	.	.	3	6	5	.	4	.	.	.	.	.	.	.	.	.	.	.	.	8	.	.	.	7	.
Races extremely fast or slips in changing from "D <sub>3</sub> " to "D <sub>2</sub> " when depressing pedal.	1	.	.	2	.	.	.	3	5	.	4	.	.	8	.	0	.	.	.	.	.	.	9	7	.	.	.	6	.	.
Races extremely fast or slips in changing from "D <sub>4</sub> " or "D <sub>3</sub> " to "D <sub>1</sub> " when depressing pedal.	1	.	.	2	.	.	.	3	5	.	4	.	.	.	.	.	.	.	.	.	.	.	.	6	7	.	8	.	.	.
Vehicle will not run in any range.	1	2	.	.	.	.	.	3	.	.	4	.	.	.	.	.	.	.	.	.	9	5	.	6	.	.	.	8	7	10
Transmission noise in "D", "2", "1" and "R" ranges.	1	.	.	.	.	.	.	.	.	.	.	.	.	.	.	.	.	.	.	.	2	.	.	.	.	.	.	.	.	.

## Disassembly (Cont'd)

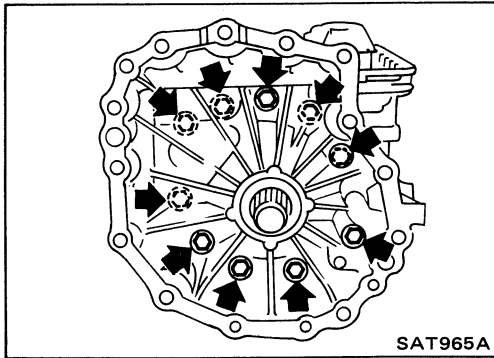

17. Remove adapter case.
  - a. Remove adapter case from transmission case.
  - b. Remove adapter case gasket from transmission case.

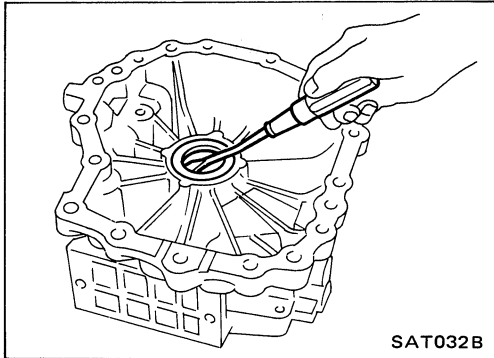

- c. Remove oil seal from rear extension.
  - **Do not remove oil seal unless it is to be replaced.**

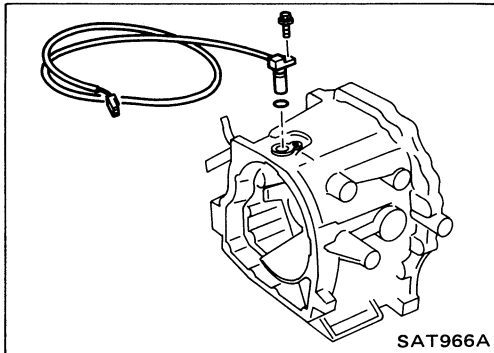

- d. Remove revolution sensor from adapter case.
- e. Remove O-ring from revolution sensor.

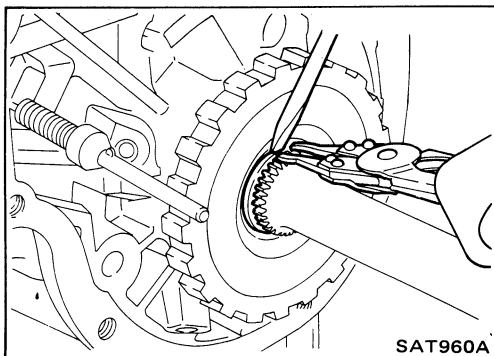

18. Remove output shaft and parking gear.
  - a. Remove rear snap ring from output shaft.

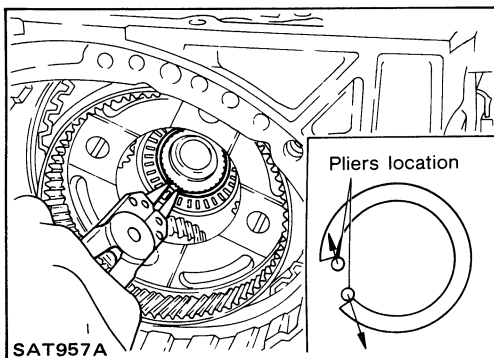

- b. Slowly push output shaft all the way forward.
  - **Do not use excessive force.**
- c. Remove snap ring from output shaft.

**Control Valve Assembly (Cont'd)**

**Pilot filter**

- Check to make sure that filter is not clogged or damaged.

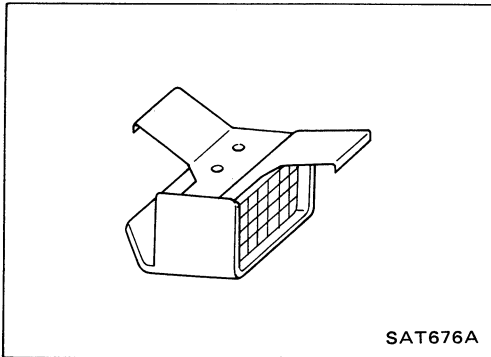

SAT676A

**Lock-up solenoid**

- Check that filter is not clogged or damaged.
- Measure resistance. — Refer to “Electrical System”.

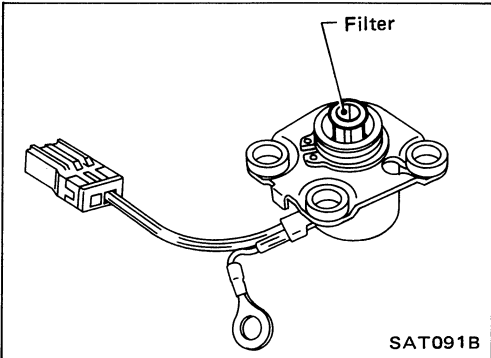

SAT091B

**Line pressure solenoid**

- Check that filter is not clogged or damaged.
- Measure resistance. — Refer to “Electrical System”.

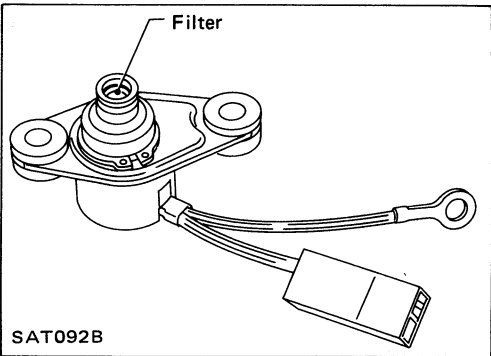

SAT092B

**3-unit solenoid assembly (Overrun clutch solenoid and shift solenoids A and B)**

- Measure resistance of each solenoid. — Refer to “Electrical System”.

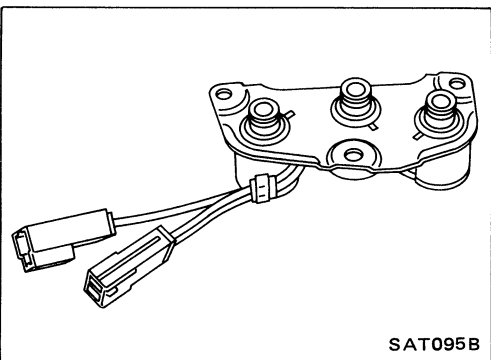

SAT095B

**Fluid-temperature sensor -1 and -2**

- Measure resistance. — Refer to “Electrical System”.

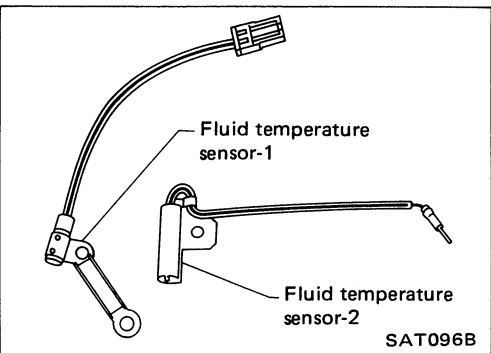

SAT096B

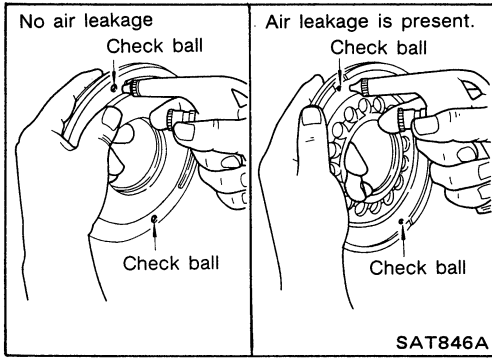

**Reverse Clutch (Cont'd)**

**Reverse clutch piston**

- Shake piston to assure that balls are not seized.
- Apply compressed air to check ball oil hole opposite the return spring to assure that there is no air leakage.
- Also apply compressed air to oil hole on return spring side to assure that air leaks past ball.

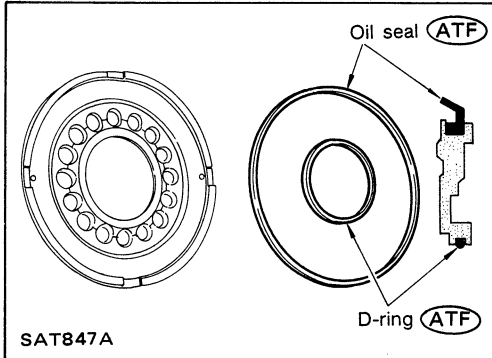

**ASSEMBLY**

1. Install D-ring and oil seal on piston.
  - Apply A.T.F. to both parts.

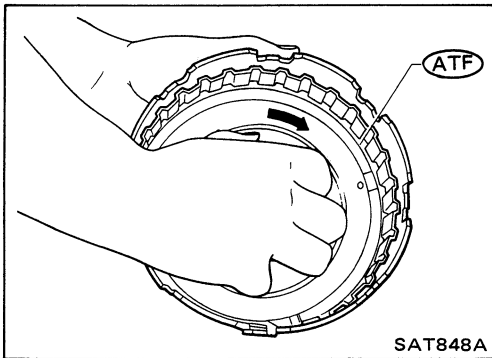

2. Install piston assembly by turning it slowly and evenly.
  - Apply A.T.F. to inner surface of drum.

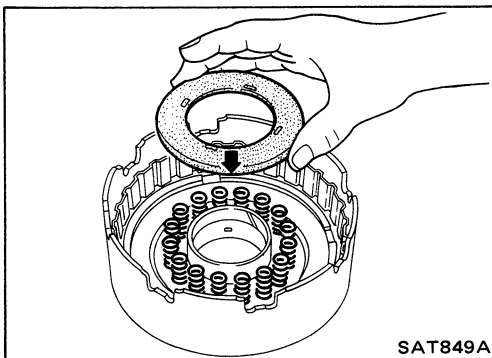

3. Install return springs and spring retainer.

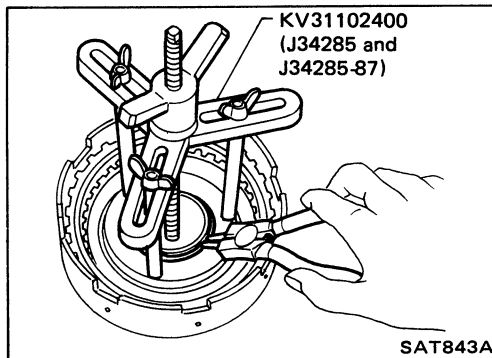

4. Install snap ring while compressing clutch springs.

**Forward Clutch Drum Assembly (Cont'd)**

4. Remove snap ring from forward clutch drum.

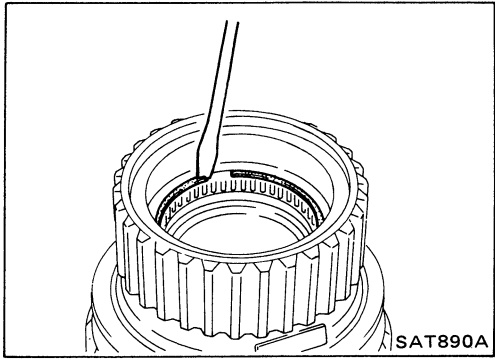

5. Remove needle bearing from forward clutch drum.

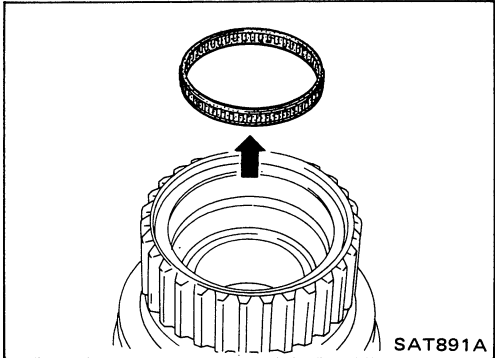

**INSPECTION**

**Forward clutch drum**

- Check spline portion for wear or damage.
- Check frictional surfaces of low one-way clutch and needle bearing for wear or damage.

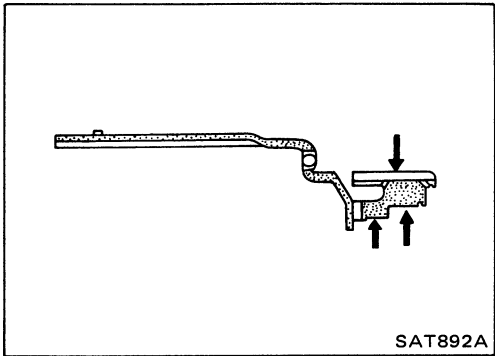

**Needle bearing and low one-way clutch**

- Check frictional surface for wear or damage.

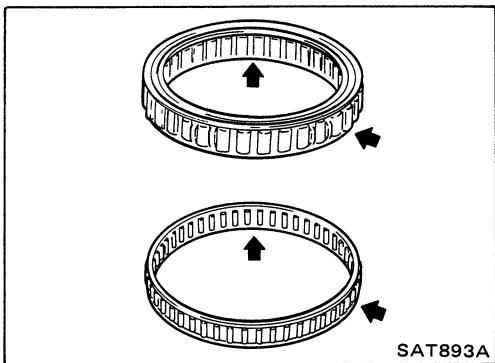

**ASSEMBLY**

1. Install needle bearing in forward clutch drum.

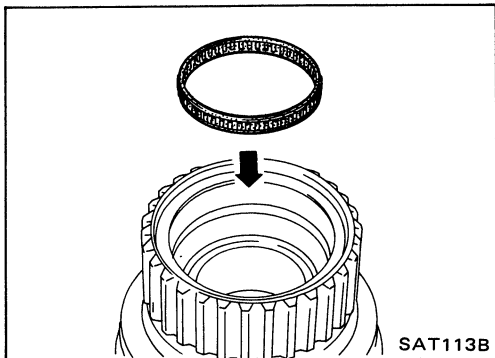

Assembly (Cont'd)

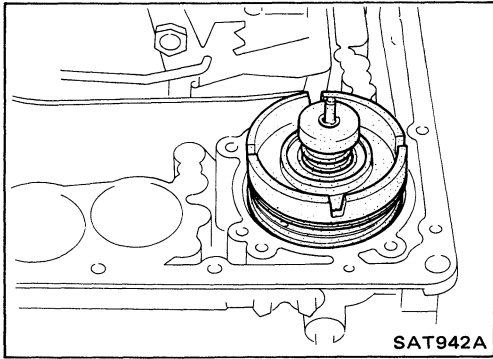

- b. Install band servo piston onto transmission case.
- Apply A.T.F. to O-ring of band servo piston and transmission case.
- c. Install gasket for band servo onto transmission case.

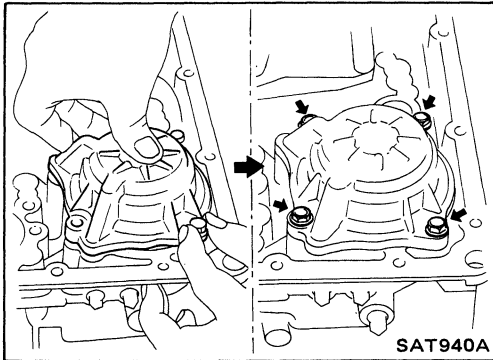

- d. Install band servo retainer onto transmission case.

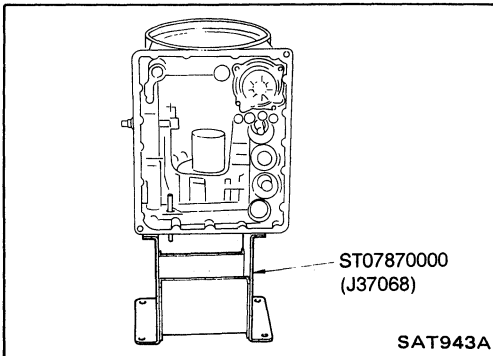

- 4. Install rear side clutch and gear components.
- a. Place transmission case in vertical position.

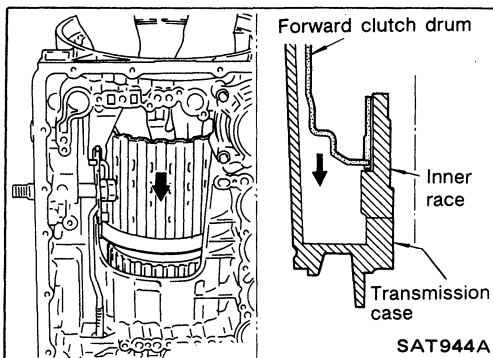

- b. Slightly lift forward clutch drum assembly and slowly rotate it clockwise until its hub passes fully over the clutch inner race inside transmission case.

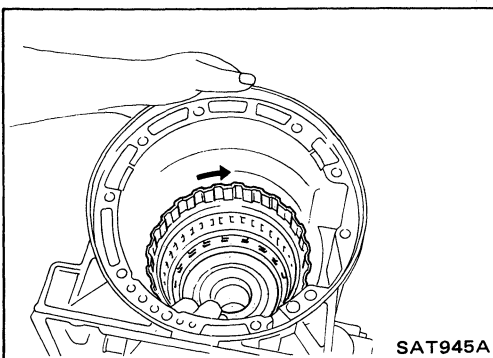

- c. Check to be sure that rotation direction of forward clutch assembly is correct.

**Assembly (Cont'd)**

- e. Install control valve assembly on transmission case.
- f. Install connector tube brackets and tighten bolts **(A)** and **(B)**.
- **Check that terminal assembly harness does not catch.**

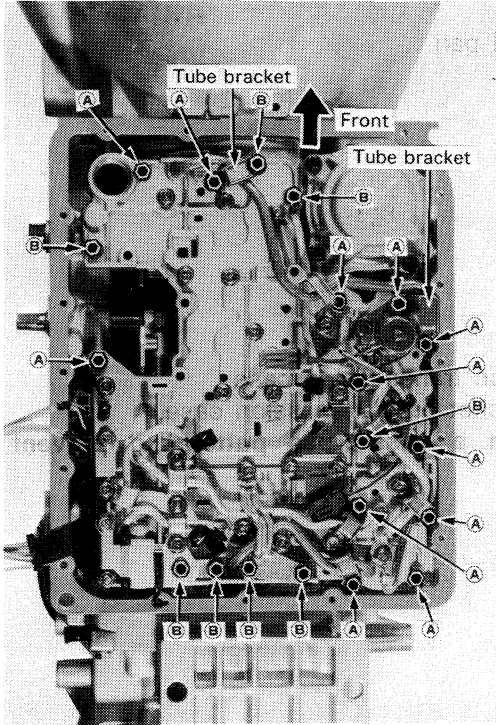

Bolt	Length
<b>(A)</b>	37 mm (1.46 in)
<b>(B)</b>	50 mm (1.97 in)

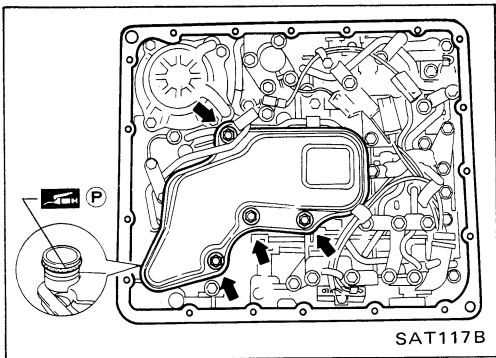

- g. Install O-ring on oil strainer.
- **Apply petroleum jelly to O-ring.**
- h. Install oil strainer on control valve.

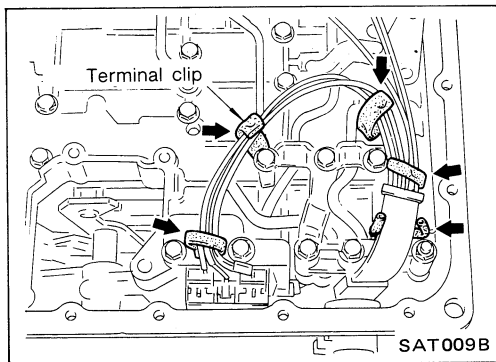

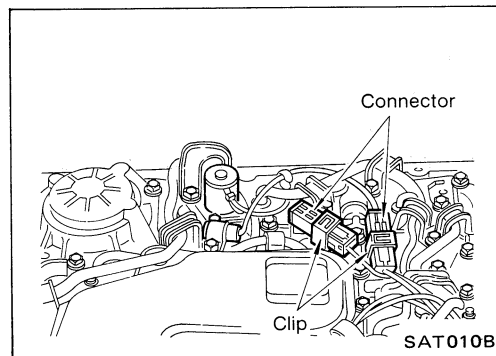

- i. Securely fasten terminal harness with clips.



- j. Install lock-up solenoid and fluid temperature sensor 1 and 2 connectors.

# PREPARATION

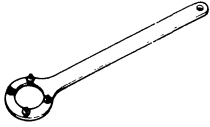
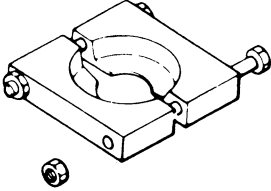
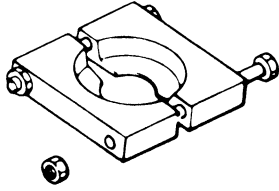
## SPECIAL SERVICE TOOLS

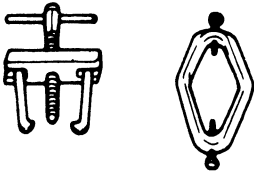
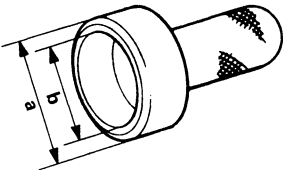
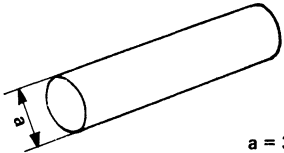
Tool number (Kent-Moore No.) Tool name	Description
ST38060002 (J34311) Flange wrench	 <p>Removing companion flange nut Installing companion flange nut</p>
ST30021000 (J22912-01) Puller	 <p>Removing counter gear front bearing (Use with ST36710010) Removing L &amp; H hub</p>
ST30031000 (J22912-01) Puller	 <p>Removing counter gear rear bearing (Use with ST36710010)</p>
ST33290001 (J25810-A) Puller	 <p>Removing center case oil seal Removing rear oil seal</p>
ST33051001 (J22888) Puller	 <p>Removing companion flange</p>
ST30720000 ① (J25273) ② (J25405) Drift	 <p>① Installing center case oil seal ② Installing rear oil seal</p> <p>a = 77 mm (3.03 in) dia. b = 55.5 mm (2.185 in) dia.</p>
ST36710010 ( - ) Drift	 <p>Removing counter gear front bearing (Use with ST30021000) Removing counter gear rear bearing (Use with ST30031000)</p> <p>a = 34.5 mm (1.358 in) dia.</p>

## DISASSEMBLY

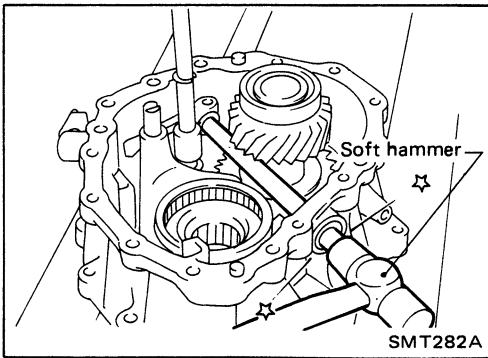

- c. Remove lock pin of inner shift lever and drive out cross shaft with plug.

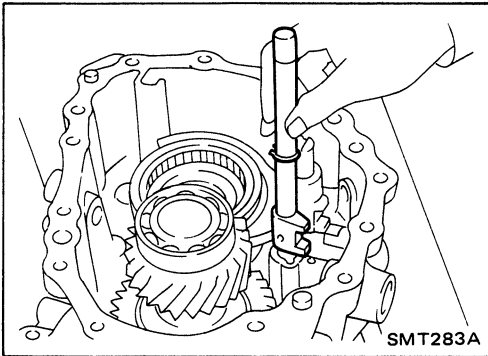

- d. Remove 2-4 shift rod.

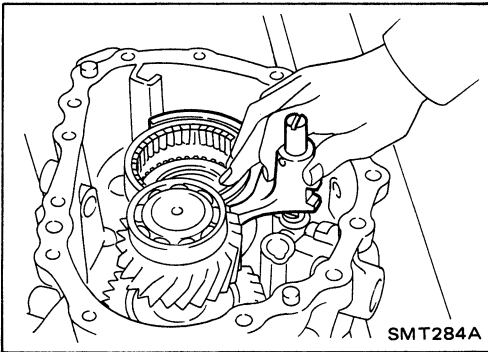

- e. Remove L & H shift rod and fork assembly with coupling sleeve.

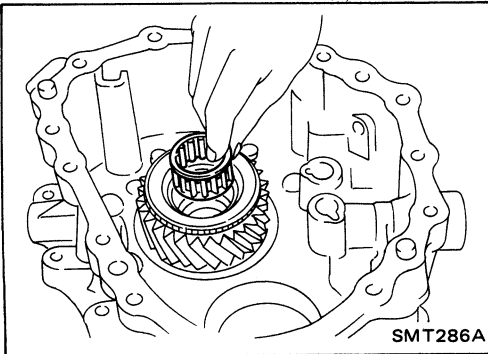

- f. Remove needle bearing from main gear.

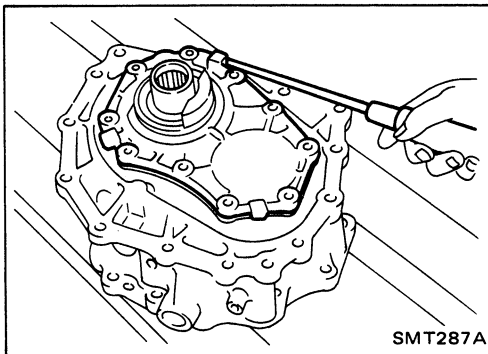

- g. Remove bolts securing front case cover and then remove case.

## ASSEMBLY

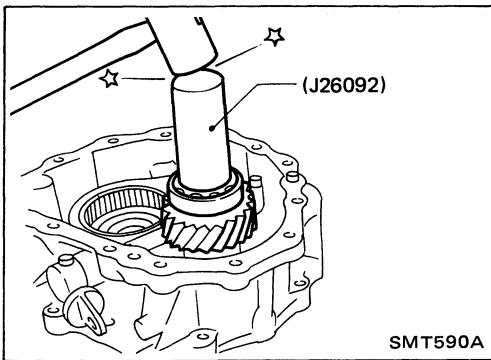

2. Select counter gear rear bearing shim.
- a. Seat counter gear assembly.

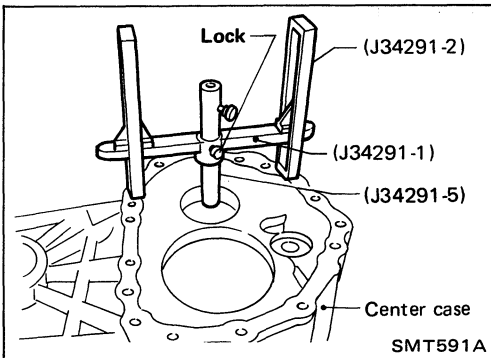

- b. Place J34291-1 (bridge), J34291-2 (legs) and J34291-5 (gauging cylinder) on machined surface of center case and allow gauging cylinder to rest on top outer portion of counter gear rear bearing. Lock gauging cylinder in place.

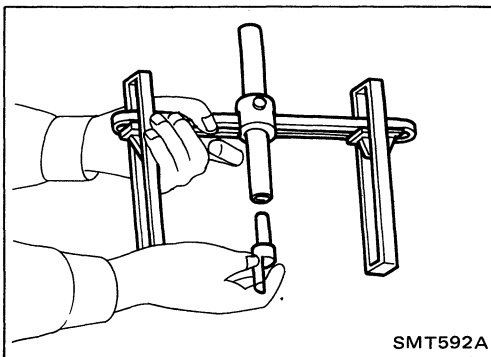



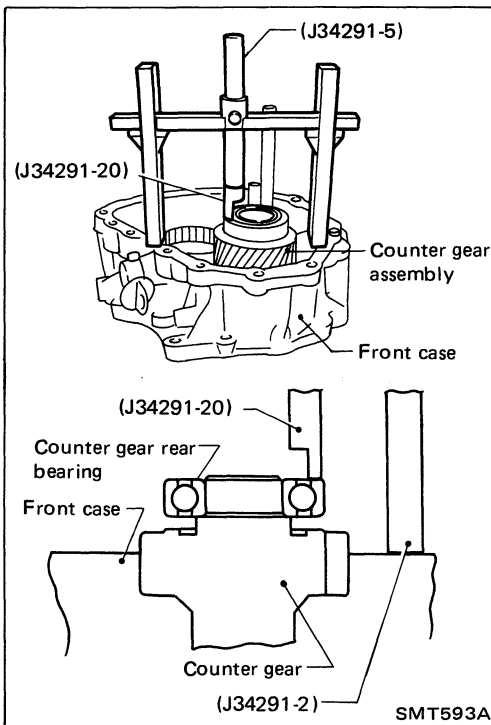



- c. Insert J34291-20 (gauging plunger) into J34291-5 (gauging cylinder).

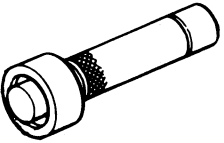
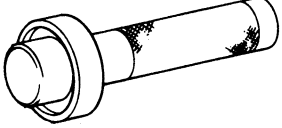
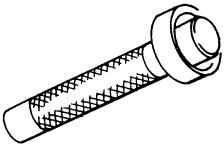

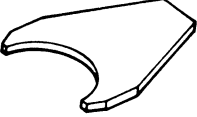
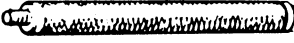
- d. Place bridge, legs, gauging cylinder and gauging plunger onto machined surface of front case assembly, and allow gauging plunger to drop until it contacts counter gear rear bearing mating surface.

## PREPARATION

Tool number (Kent-Moore No.) Tool name	Description	Unit application				
		R180A	R200A	H190A	C200	H233B
ST33230000 (J25805-01) Differential side bearing drift	 Installing side bearing inner cone	X	—	X	X	—
KV38100300 (J25523) Differential side bearing drift	 Installing side bearing inner cone	—	X	—	—	—
ST33190000 ( — ) Differential side bearing drift Equivalent tool (J25523)	 Installing side bearing inner cone	—	—	—	—	X
ST33081000 ( — ) Side bearing puller adapter	 Installing side bearing inner cone	—	—	—	—	X
KV38100600 (J25267) Side bearing spacer drift	 Installing side bearing spacer	—	X	—	X	—
ST30611000 (J25742-1) Drift	 Installing pinion rear bearing outer race	X	X	X	X	X
ST30621000 (J25742-5) Drift	 Installing pinion rear bearing outer race	X	X	X	X	X
ST30701000 (J25742-2) Drift	 Installing pinion front bearing outer race	X	—	—	—	—
ST30613000 (J25742-3) Drift	 Installing pinion front bearing outer race	—	X	X	X	X

## Removal

- Remove propeller shaft.
- Insert plug into rear oil seal after removing propeller shaft.
- Remove axle shaft.  
Refer to RA section.

### CAUTION:

- Be careful not to damage spline, sleeve yoke and front oil seal when removing propeller shaft.

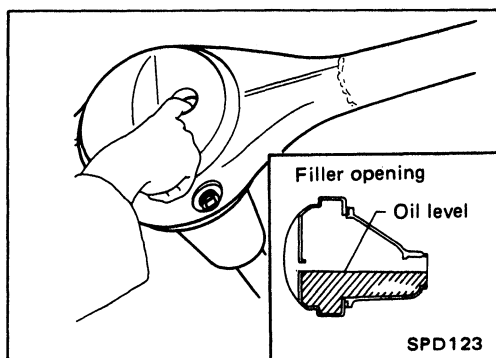

## Installation

- Fill final drive with recommended gear oil.

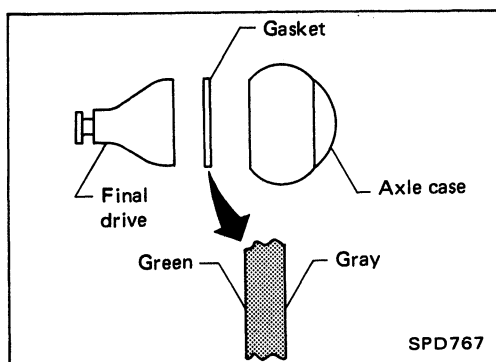

- Pay attention to the direction of gasket (H233B only).

## ADJUSTMENT (Model R180A)

### Pinion Gear Height and Pinion Bearing Preload (Cont'd)

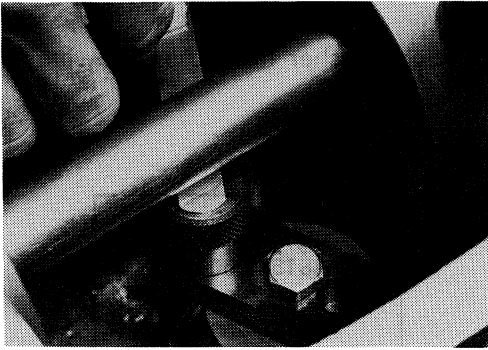

12. Select the correct *standard* pinion height adjusting washer thickness using a standard gauge of 3 mm (0.12 in) and your J-34309-101 feeler gauge. Measure the distance between the J-34309-10 "R180A" pinion height adapter and the arbor.

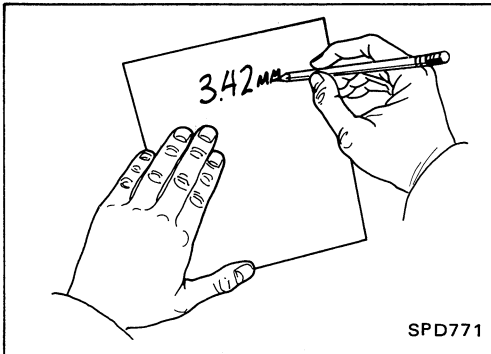

13. Write down your exact total measurement.

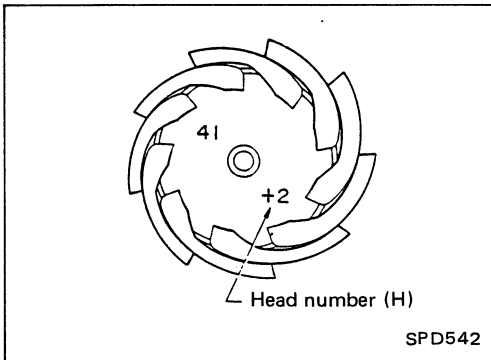

14. Correct the pinion height washer size by referring to the "pinion head number."

**Note:** There are two numbers painted on the pinion gear. The first one refers to the pinion and ring gear as a matched set and should be the same as the number on the ring gear. The second number is the "pinion head height number," and it refers to the ideal pinion height from standard for quietest operation. Use the following chart to determine the correct pinion height washer.

Pinion Head Height Number	Add or Remove from the Standard Pinion Height Washer Thickness Measurement
-6	Add 0.06 mm (0.0024 in)
-5	Add 0.05 mm (0.0020 in)
-4	Add 0.04 mm (0.0016 in)
-3	Add 0.03 mm (0.0012 in)
-2	Add 0.02 mm (0.0008 in)
-1	Add 0.01 mm (0.0004 in)
0	Use the selected washer thickness
+1	Subtract 0.01 mm (0.0004 in)
+2	Subtract 0.02 mm (0.0008 in)
+3	Subtract 0.03 mm (0.0012 in)
+4	Subtract 0.04 mm (0.0016 in)
+5	Subtract 0.05 mm (0.0020 in)
+6	Subtract 0.06 mm (0.0024 in)

## DISASSEMBLY (Model R200A)

### Final Drive Housing (Cont'd)

12. Remove pinion rear bearing inner cone and drive pinion height adjusting washer.

Tool number: ST30031000 (J22912-01)

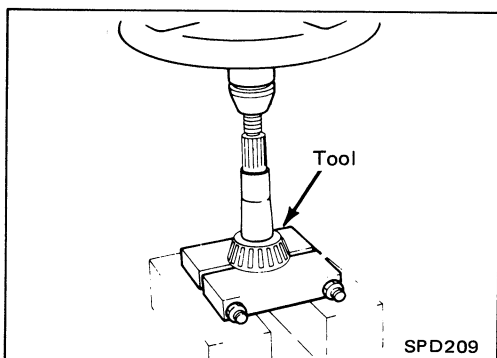

### Differential Case

1. Remove side bearing inner cones.

To prevent damage to bearing, engage puller jaws in grooves.

Tool number:

- Ⓐ ST33051001 ( - )  
Equivalent tool (J22888)
- Ⓑ ST33061000 (J8107-2)

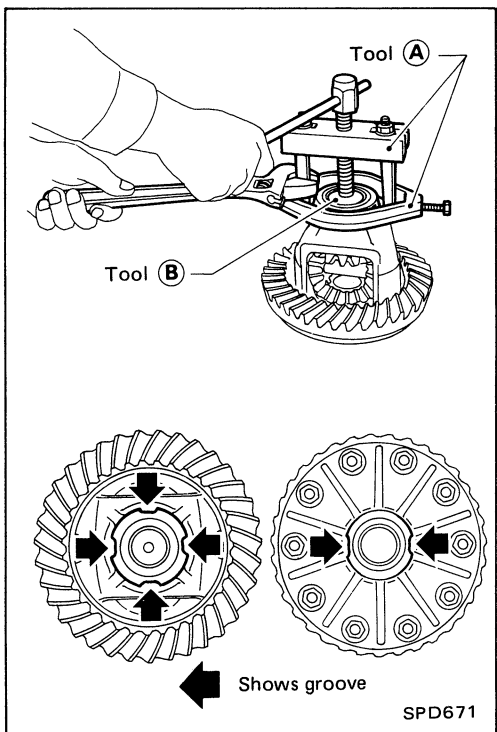

Be careful not to confuse the right and left hand parts.

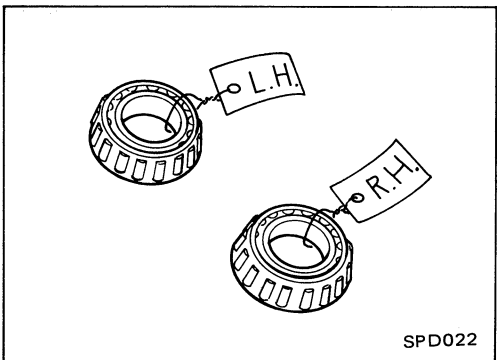

2. Loosen ring gear bolts in a criss-cross fashion.
3. Tap ring gear off the differential case with a soft hammer. Tap evenly all around to keep ring gear from binding.

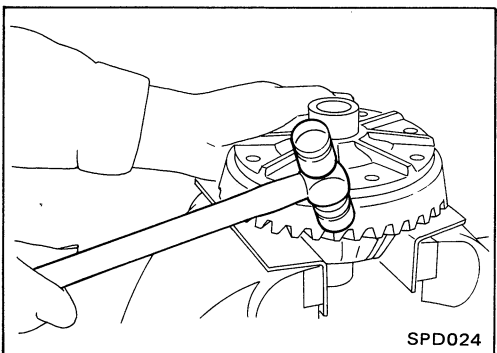

## ASSEMBLY (Model R200A)

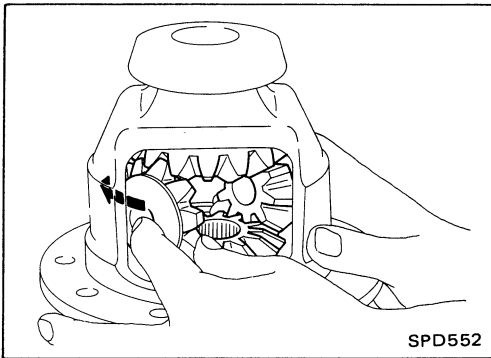

### Differential Case

1. Install side gears, pinion mate gears, thrust washers and thrust block into differential case.

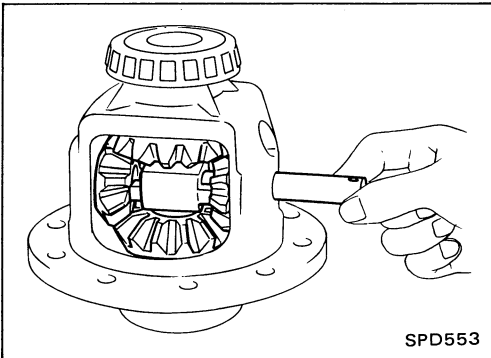

2. Fit pinion mate shaft to differential case so that it meets lock pin holes.

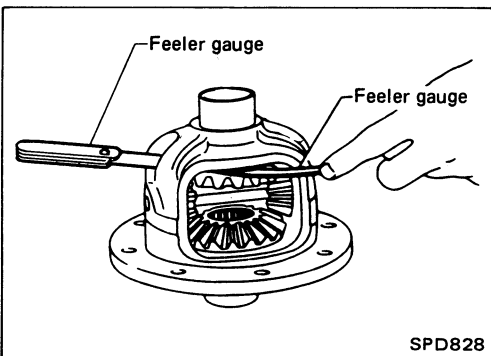

3. Adjust clearance between rear face of side gear and thrust washer by selecting side gear thrust washer. (Refer to S.D.S.)

**Clearance between side gear thrust washer and differential case:**

**0.10 - 0.20 mm (0.0039 - 0.0079 in)**

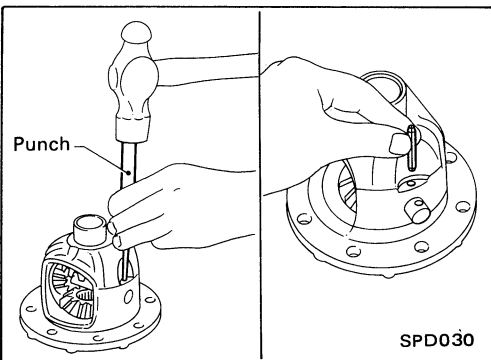

4. Install pinion mate shaft lock pin with a punch. **Make sure lock pin is flush with case.**

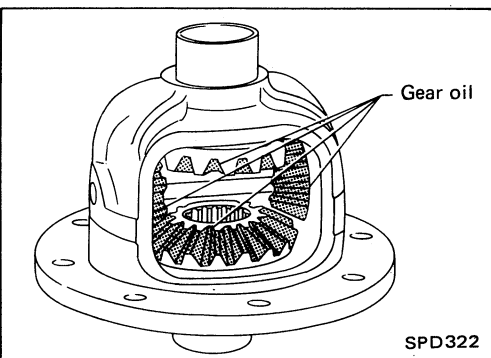

5. Apply gear oil to gear tooth surfaces and thrust surfaces and check to see they turn properly.

## ADJUSTMENT (Model H190A)

### Side Bearing Preload (Cont'd)

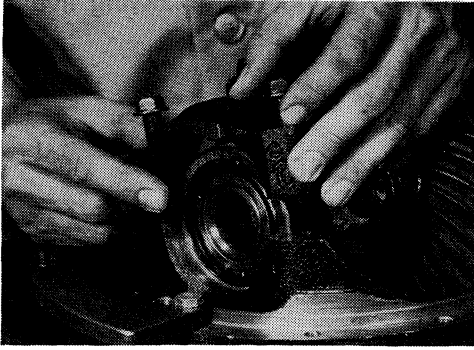

5. Install carrier and bearings into the final drive housing. Install side bearing caps. Torque the bolts and tap on the caps with a soft hammer to seat the bearings.

**Side bearing cap bolt torque:**

**Specification 49 - 59 N·m  
(5 - 6 kg-m, 36 - 43 ft-lb)**

6. After turning the carrier several times to seat the bearings, measure carrier turning force with spring gauge J-8129.

**Turning force specification:**

**34.3 - 39.2 N (3.5 - 4.0 kg, 7.7 - 8.8 lb)  
of pulling force at the ring gear bolt.**

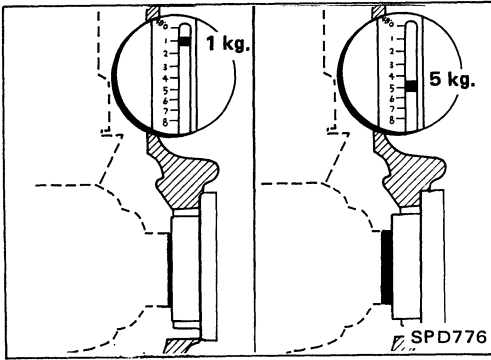

7. If necessary, correct the carrier bearing preload by adding to or subtracting from the *total* amount of shim thickness.

Add shim thickness to increase turning force on the carrier.

Subtract shim thickness to decrease turning force on the carrier.

## DISASSEMBLY (Model C200)

### Differential Carrier (Cont'd)

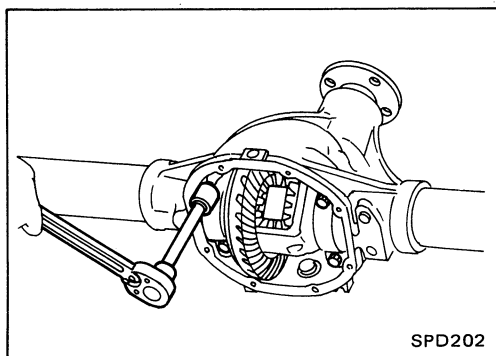

3. Remove side bearing caps.

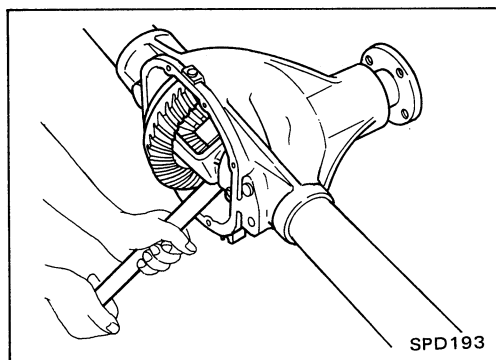

4. Remove differential case assembly with pry bar.

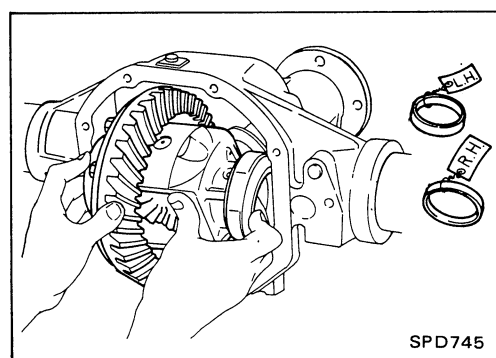

Keep the side bearing outer races together with their respective inner cones – do not mix them up.

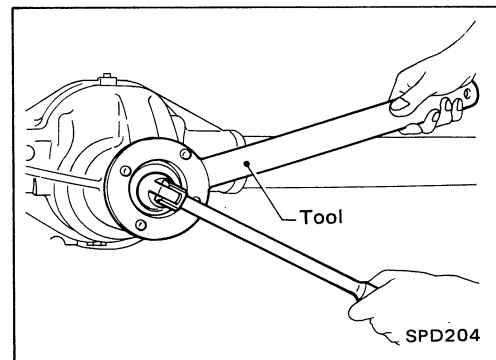

5. Remove pinion nut with Tool.

**Tool number:**

**Except Van and Wagon models**

**ST38060002 (J34311)**

**Van and Wagon models**

**KV38104700 (J34311)**

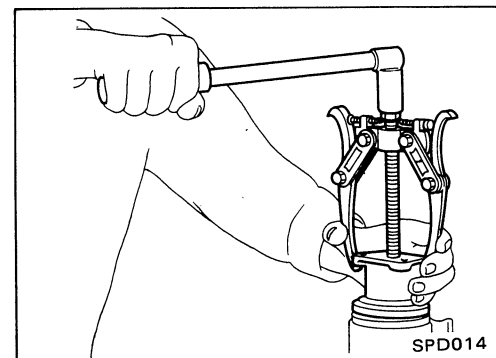

6. Remove companion flange with puller.

# ASSEMBLY (Model C200)

## Differential Case —4-pinion type— (Cont'd)

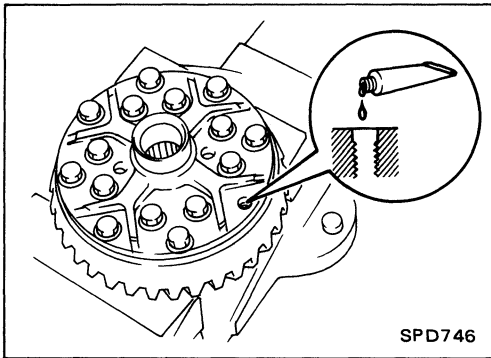

5. Place differential case on ring gear.
6. Apply locking agent [Locktite (stud lock) or equivalent] to ring gear bolts, and install them.

Tighten bolts in a criss-cross fashion, lightly tapping bolt head with a hammer.

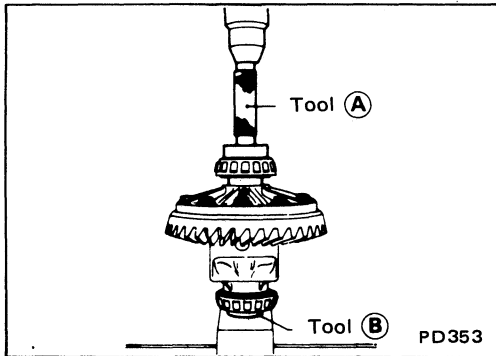

7. Press-fit side bearing inner cones on differential case with Tool.

Tool number:

- (A) ST33230000 (J25805-01)
- (B) ST33061000 (J8107-2)

## Differential Carrier

1. Press-fit front and rear bearing outer races with Tools.

Tool number:

- (A) ST30611000 (J25742-1)
- (B) ST30621000 (J25742-5)
- (C) ST30613000 (J25742-3)

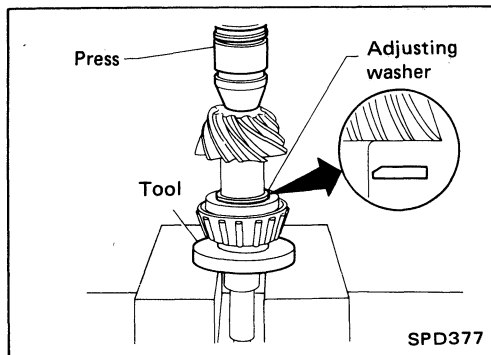
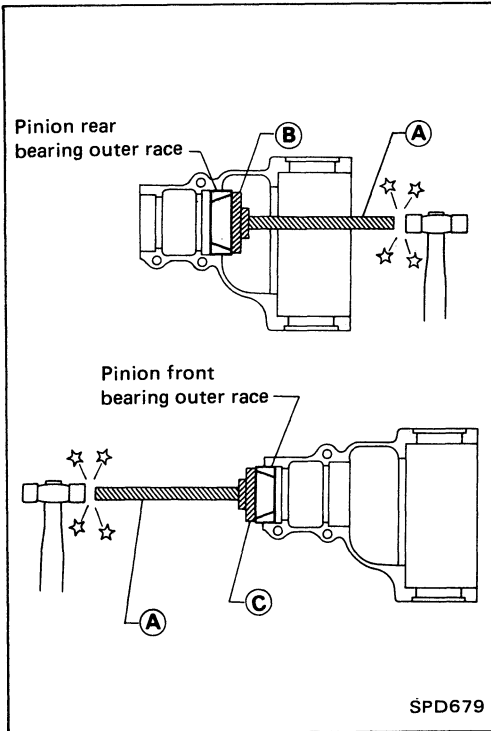

2. Select pinion height adjusting washer, referring to Adjustment.
3. Install pinion height adjusting washer in drive pinion, and press-fit rear bearing inner cone in it, with press and Tool.

Tool number: ST30901000 ( - )

Equivalent tool (J26010-01)

## LIMITED SLIP DIFFERENTIAL (For H233B)

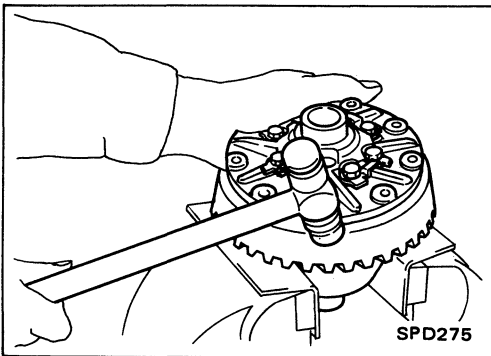

### Disassembly

1. Remove side bearing inner cone with Tool.
2. Remove ring gear by spreading out lock straps.
3. Loosen ring gear bolts in a criss-cross fashion.
4. Tap ring gear off gear case with a soft hammer.  
Tap evenly all around to keep ring gear from binding.

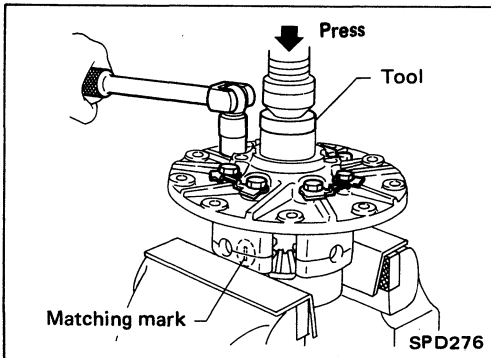

5. Remove differential case by spreading out lock straps.
6. Remove couple bolts on differential cases A and B with a press.

Tool number: ST33081000 ( - )

7. Separate differential case A and B.

Draw out component parts (discs and plates, etc.).

Put marks on gears and pressure rings so that they can be reinstalled in their original positions from which they were removed.

### Inspection

#### CONTACT SURFACES

1. Clean the disassembled parts in suitable solvent and blow dry with compressed air.
2. If following surfaces are found with burrs or scratches, smooth with oil stone.

- ① Differential case A
- ② Differential case B
- ③ Side gear
- ④ Pinion mate gear
- ⑤ Pinion mate shaft
- ⑥ Thrust block
- ⑦ Friction plate guide

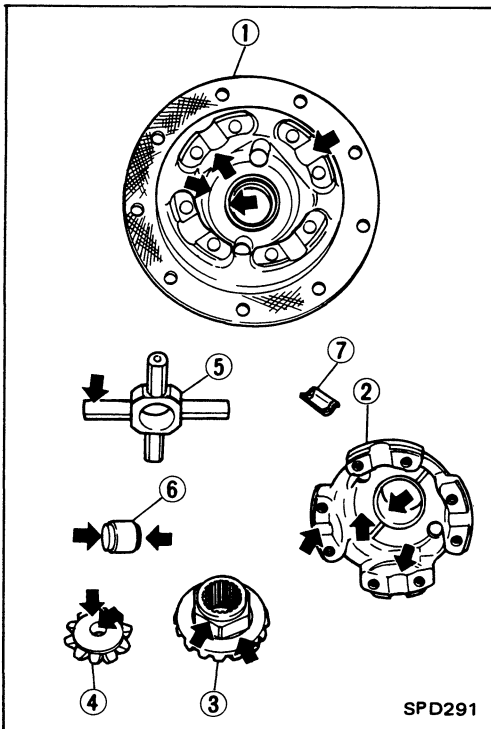

#### DISC AND PLATE

1. Clean the discs and plates in suitable solvent and blow dry with compressed air.
2. Inspect discs and plates for wear, nicks and burrs.

## ASSEMBLY (Model H233B)

### Differential Case —2-pinion type— (Cont'd)

8. Press-fit side bearing inner cones on differential case with Tool.

Tool number:

- Ⓐ ST33190000 ( — )  
Equivalent tool (J25523)
- Ⓑ ST33081000 ( — )

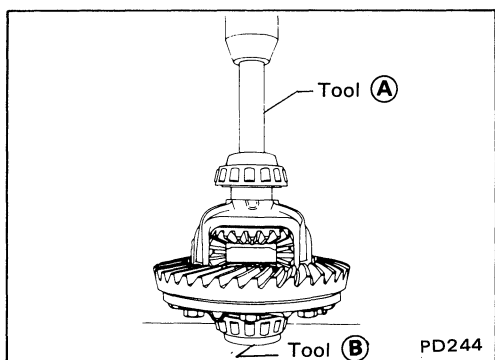

### Differential Case —4-pinion type—

1. Measure clearance between side gear thrust washer and differential case.

**Clearance between side gear thrust washer and differential case (A - B):**

**0.10 - 0.20 mm (0.0039 - 0.0079 in)**

The clearance can be adjusted with side gear thrust washer.  
(Refer to S.D.S.)

2. Apply gear oil to gear tooth surfaces and thrust surfaces and check to see they turn properly.

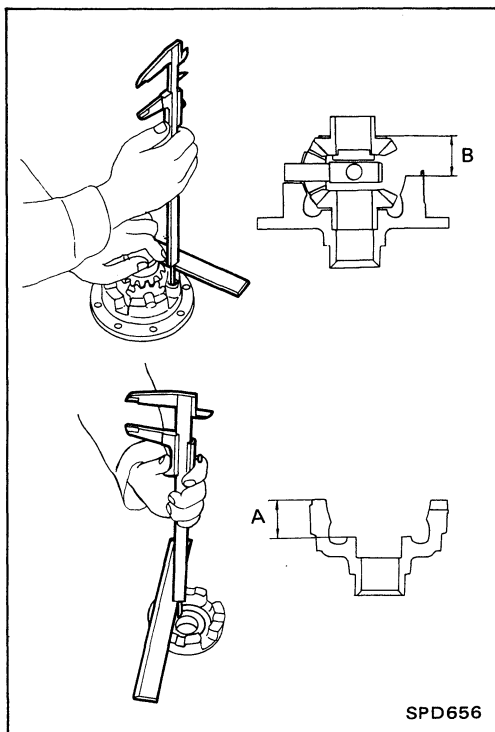

3. Install differential case L.H. and R.H.
4. Install differential case on ring gear.

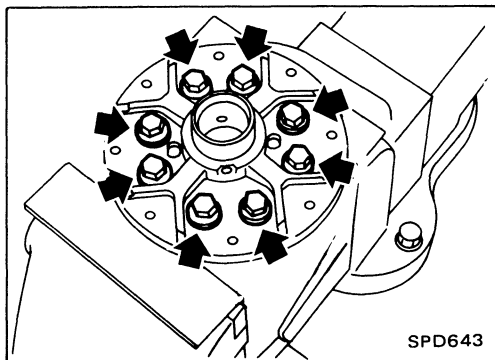

5. Place differential case on ring gear.
6. Apply locking agent [Locktite (stud lock) or equivalent] to ring gear bolts, and install them.

Tighten bolts in a criss-cross fashion, lightly tapping bolt head with a hammer.

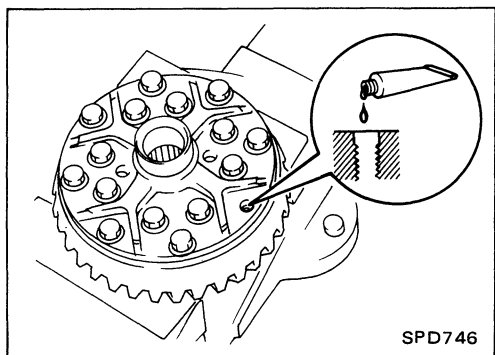

# SERVICE DATA AND SPECIFICATIONS (S.D.S.)

## Differential Carrier (Cont'd)

### TIGHTENING TORQUE (R180A)

Unit	N·m	kg·m	ft·lb
<b>Final drive installation</b>			
Rear cover to mounting insulator	68 - 87	6.9 - 8.9	50 - 64
Mounting insulator to body	68 - 87	6.9 - 8.9	50 - 64
Differential carrier to suspension member	68 - 87	6.9 - 8.9	50 - 64
Companion flange to propeller shaft	39 - 44	4.0 - 4.5	29 - 33
Companion flange to drive shaft	34 - 44	3.5 - 4.5	25 - 33
<b>Final drive assembly</b>			
Drive pinion nut	167 - 196	17 - 20	123 - 145
Ring gear bolt	93 - 113	9.5 - 11.5	69 - 83
Differential case couple bolt (4-pinion)	64 - 78	6.5 - 8.0	47 - 58
Side retainer bolt	9 - 12	0.9 - 1.2	6.5 - 8.7
Rear cover fixing bolt	39 - 49	4 - 5	29 - 36
Filler and drain plugs	39 - 59	4 - 6	29 - 43

### TIGHTENING TORQUE (R200A)

Unit	N·m	kg·m	ft·lb
<b>Final drive installation</b>			
Rear cover to mounting insulator	68 - 87	6.9 - 8.9	50 - 64
Mounting insulator to body	68 - 87	6.9 - 8.9	50 - 64
Differential carrier to suspension member	68 - 87	6.9 - 8.9	50 - 64
Companion flange to propeller shaft	39 - 44	4.0 - 4.5	29 - 33
Companion flange to drive shaft	34 - 44	3.5 - 4.5	25 - 33
<b>Final drive assembly</b>			
Drive pinion nut	186 - 294	19 - 30	137 - 217
Ring gear bolt [using Locktite (stud lock) or equivalent]	132 - 152	13.5 - 15.5	98 - 112
Side bearing cap bolt	88 - 98	9.0 - 10.0	65 - 72
Rear cover fixing bolt	39 - 49	4 - 5	29 - 36
Filler and drain plugs	39 - 59	4 - 6	29 - 43

### TIGHTENING TORQUE (H190A)

Unit	N·m	kg·m	ft·lb
<b>Final drive installation</b>			
Differential carrier to rear axle case fixing bolt	17 - 25	1.7 - 2.5	12 - 18
Companion flange to propeller shaft	39 - 44	4.0 - 4.5	29 - 33
<b>Final drive assembly</b>			
Drive pinion nut	127 - 294	13 - 30	94 - 217
Ring gear bolt			
M12 bolt	132 - 152	13.5 - 15.5	98 - 112
Side bearing cap bolt	49 - 59	5 - 6	36 - 43
Drain and filler plugs	59 - 98	6 - 10	43 - 72

### TIGHTENING TORQUE (C200)

Unit	N·m	kg·m	ft·lb
<b>Final drive installation</b>			
Companion flange to propeller shaft			
2WD	39 - 44	4.0 - 4.5	29 - 33
4WD	78 - 88	8 - 9	58 - 65
<b>Final drive assembly</b>			
Drive pinion nut	127 - 294	13 - 30	94 - 217
Ring gear bolt			
M12 bolt	132 - 152	13.5 - 15.5	98 - 112
Side bearing cap bolt	88 - 98	9 - 10	65 - 72
Rear cover fixing bolt			
Bolt with spring washer type	11 - 14	1.1 - 1.4	8 - 10
Filler plug	39 - 59	4 - 6	29 - 43
Drain plug	59 - 98	6 - 10	43 - 72

### TIGHTENING TORQUE (H233B)

Unit	N·m	kg·m	ft·lb
<b>Final drive installation</b>			
Differential carrier to rear axle case fixing bolt	27 - 36	2.8 - 3.7	20 - 27
Companion flange to propeller shaft	78 - 88	8 - 9	58 - 65
<b>Final drive assembly</b>			
Drive pinion nut	196 - 245	20 - 25	145 - 181
Ring gear bolt	132 - 152	13.5 - 15.5	98 - 112
Side bearing cap bolt	93 - 103	9.5 - 10.5	69 - 76
Drain and filler plugs	59 - 98	6 - 10	43 - 72

**Front Wheel Alignment (Cont'd)**

**Caster**

To adjust caster, make a difference in thickness between front and rear shims.

**Caster (Unladen):**

Refer to S.D.S.

- When front shim(s) is 1.0 mm (0.039 in) thicker than rear one(s),

	<b>2WD</b>	<b>4WD</b>
<b>Caster increases</b>	<b>19'</b>	<b>26'</b>
<b>Camber increases</b>	<b>6'</b>	<b>6'</b>

- When rear shim(s) is 1.0 mm (0.039 in) thicker than front one(s),

	<b>2WD</b>	<b>4WD</b>
<b>Caster decreases</b>	<b>19'</b>	<b>20'</b>
<b>Camber increases</b>	<b>6'</b>	<b>8'</b>

- Difference of total thickness of the front and rear must be within 2.0 mm (0.079 in).
- When caster is adjusted, camber angle changes and camber needs to be measured again. If necessary, adjust camber.

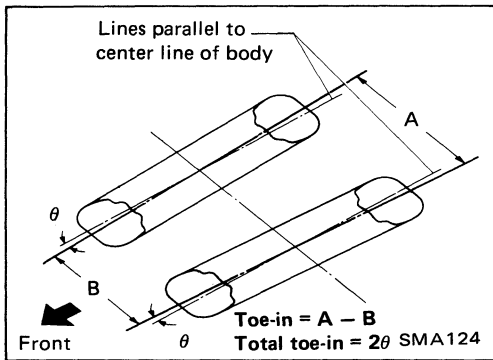
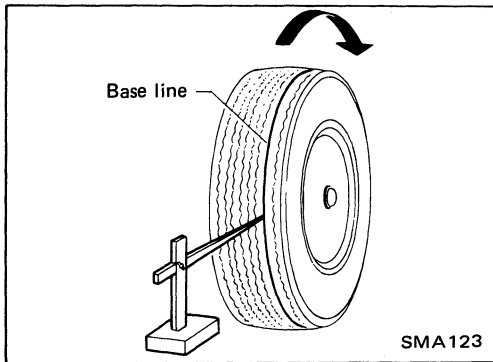

**TOE-IN**

1. Mark a base line across the tread.

After lowering front of vehicle, move it up and down to eliminate friction, and set steering wheel in straight ahead position.

2. Measure toe-in.

Measure distance "A" and "B" at the same height as hub center.

**Toe-in (Unladen):**

Refer to S.D.S.

## FRONT AXLE — Knuckle Spindle

### Removal (Cont'd)

- (3) Remove ball joint tightening nuts.  
**Support lower link with jack.**
- (4) Remove knuckle spindle from upper and lower links.

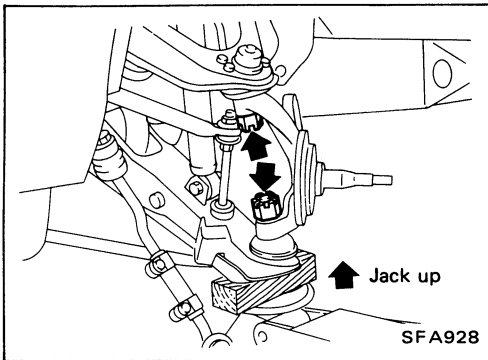

### Inspection

#### KNUCKLE SPINDLE

- Check knuckle spindle for deformation, cracks or other damage by using a magnetic exploration or dyeing test.

#### BEARING SPACER — 2WD —

- Check bearing spacer for damage.

#### NEEDLE BEARING — 4WD —

- Check needle bearing for wear, scratches, pitting, flaking and burn marks.

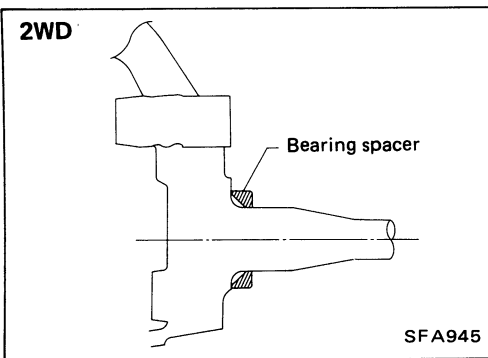

### Installation

- Install bearing spacer onto knuckle spindle. — 2WD —  
**Make sure that bearing spacer is facing in proper direction.**  
**Apply multi-purpose grease.**

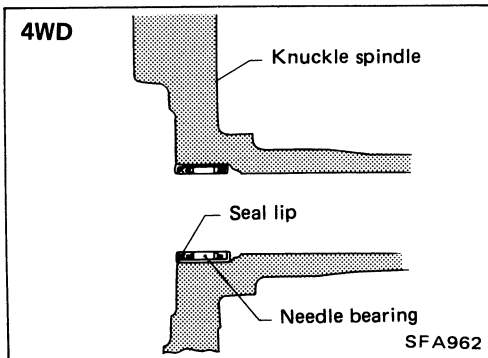

- Install needle bearing into knuckle spindle. — 4WD —  
**Make sure that needle bearing is facing in proper direction.**  
**Apply multi-purpose grease.**

# FRONT SUSPENSION

## Torsion Bar Spring (Cont'd)

5. Set anchor arm.

Standard length "G":

2WD 6 - 18 mm (0.24 - 0.71 in)

4WD 50 - 60 mm (1.97 - 2.36 in)

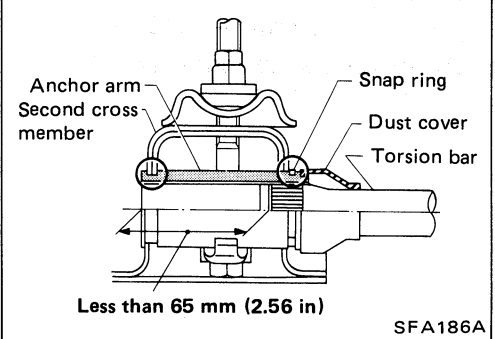
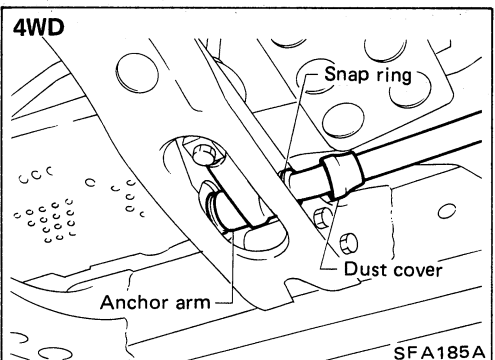
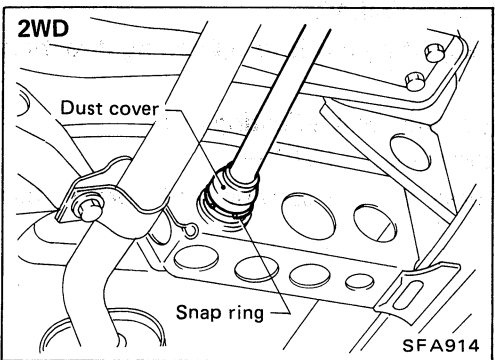
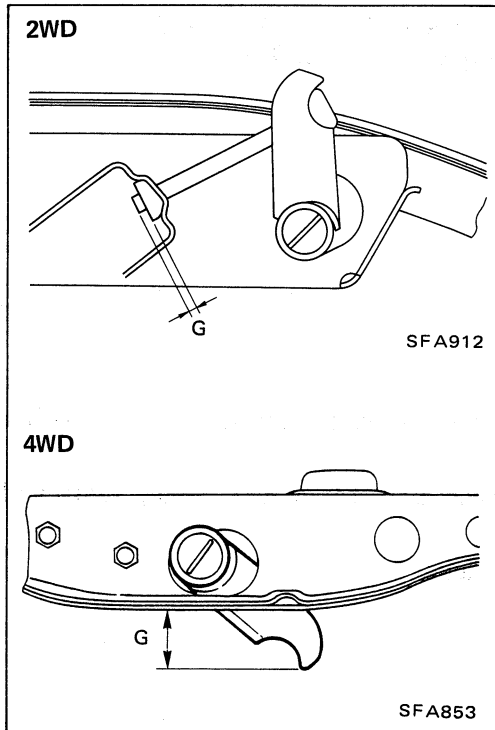

6. Install snap ring to anchor arm and dust cover.

—2WD—

Make sure that snap ring is properly installed on the anchor arm groove.

—4WD—

Make sure that snap ring and anchor arm are properly installed.

# SERVICE DATA AND SPECIFICATIONS (S.D.S.)

## General Specifications

### TORSION BAR SPRING

Applied model	2WD		4WD
	Heavy duty and standard	Except Heavy duty and standard	
Spring diameter x Length Truck	24.4 x 885 (0.961 x 34.84)	22.6 x 885 (0.890 x 34.84)	25.0 x 1,205 (0.984 x 47.44)
Van and Wagon	24.8 x 1,230 (0.976 x 48.43)		

### SHOCK ABSORBER

Applied model	Truck			Van and Wagon		
	2WD		4WD	2WD	4WD	
	Except Heavy duty and Canada	Heavy duty and Canada				
Shock absorber type	Non-adjustable			Non-adjustable	Adjustable	
Stroke mm (in)	120 (4.72)		110 (4.33)	141 (5.55)	99 (3.90)	
Damping force [At 0.3 m (1.0 ft) sec.]					TOURING	SPORT
Expansion N (kg, lb)	686 (70, 154)	1,275 (130, 287)	1,471 (150, 331) 1,961 (200, 441)*	1,471 (150, 331)	1,667 (170, 375)	2,550 (260, 573)
Compression N (kg, lb)	275 (28, 62)	392 (40, 88)	245 (25, 55) 539 (55, 121)*	588 (60, 132)	539 (55, 121)	834 (85, 187)

\* : With 31 x 10.5R15 tire models

### STABILIZER BAR

Model	Item	Diameter mm (in)
Truck	2WD	23 (0.91)
	4WD	20 (0.79)
Van, Wagon	4WD	23 (0.91)

### TENSION ROD

Applied model	2WD
Diameter mm (in)	22 (0.87)

### DRIVE SHAFT

Model	Wheel side	Differential carrier side
Model	ZF100	TS82F
Joint type	Rzeppa	Tripod
Maximum winding degree	46.5°	23°
Length "L" mm (in)		
Maximum	416 (16.38)	
Standard	302 (11.89)	

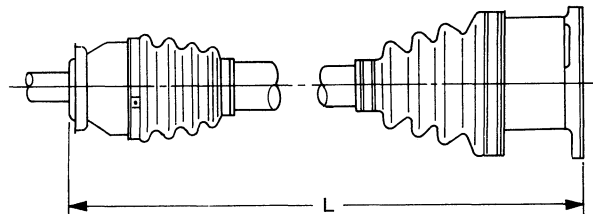

Grease Name	Nissan genuine grease or equivalent	
Capacity g (oz)	210 - 220 (7.41 - 7.76)	150 - 160 (5.29 - 5.64)

## REAR AXLE — Single-tire Models

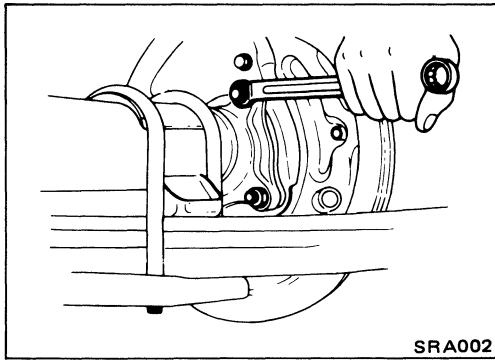

### Removal

- Disconnect parking brake cable and brake tube.
- Remove nuts securing wheel bearing cage with baffle plate.

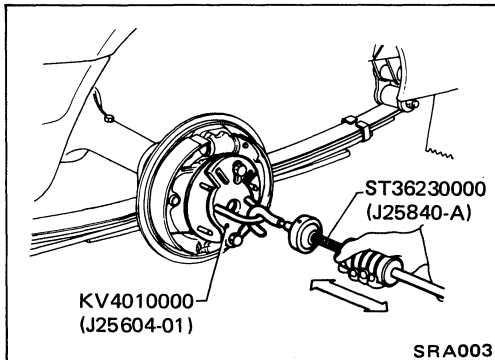

- Draw out axle shaft with Tool.  
When drawing out axle shaft, be careful not to damage oil seal.

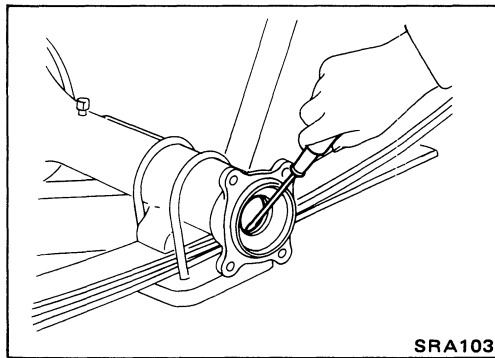

- Remove oil seal.  
Do not reuse oil seal once it is removed.  
Always install new one.

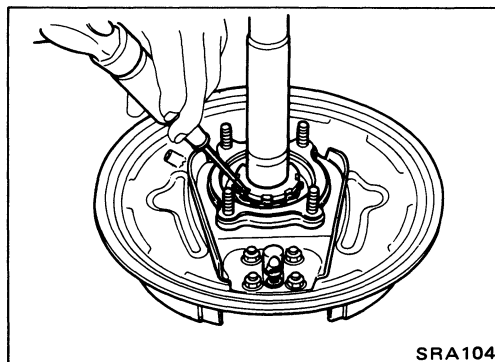

- Unbend lock washer with a screwdriver.

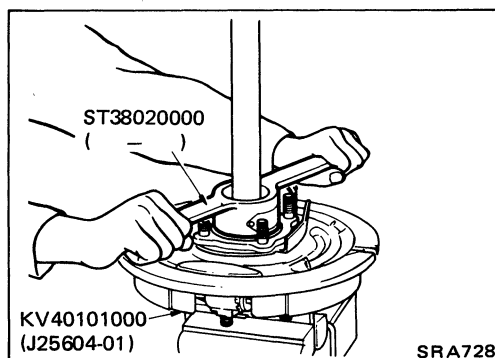

- Remove bearing lock nut with Tool.

**General Specifications (Leaf spring type)**

**LEAF SPRING**

Model	2WD			Heavy duty	4WD	
	U.S.A.	Canada	Regular Cab*			
Semi-elliptic leaf spring						
Suspension type						
Leaf spring	Length x width x thickness - number of leaves mm (in)	1,200 x 60 x 7 - 2 13 - 1 (47.24 x 2.36 x 0.28 - 2) 0.51 - 1	1,200 x 60 x 7 - 2 12 - 2 (47.24 x 2.36 x 0.28 - 2) 0.47 - 2	1,200 x 60 x 7 - 2 13 - 1 (47.24 x 2.36 x 0.28 - 2) 0.51 - 1	1,200 x 60 x 8 - 2 14 - 2 (47.24 x 2.36 x 0.31 - 2) 0.55 - 2	1,200 x 60 x 7 - 1 8 - 1 12 - 1 13 - 1 (47.24 x 2.36 x 0.28 - 1) 0.31 - 1 0.47 - 1 0.51 - 1
	Free camber "S" mm (in)	171 (6.73)	164.5 (6.48)	171 (6.73)	134.5 (5.30)	106 (4.17)
Spring constant N/mm (kg/mm, lb/in)	20.9 - 58.0 (2.13 - 5.91, 119.3 - 331.0)	22.3 - 76.5 (2.27 - 7.8, 127.1 - 436.8)	20.9 - 58.0 (2.13 - 5.91, 119.3 - 331.0)	32.6 - 114.7 (3.32 - 11.7, 185.9 - 655.2)	24.1 - 90.2 (2.46 - 9.2, 137.8 - 515.2)	
Maximum length "L" mm (in)	508 (20.00)					
Shock absorber	200 (7.87)					
Stroke mm (in)	210 (8.27)					
Damping force [0.3 m/sec. (1.0 ft/sec.)] Expansion Compression	785 (80, 176) 216 (22, 49)		981 (100, 221) 216 (22, 49)		Except Canada 785 (80, 176) 216 (22, 49) Canada 1,716 (175, 386) 343 (35, 77)	



SRA111

RA260

\*: 4-speed M/T models only

# VACUUM PIPING

## Removal and Installation

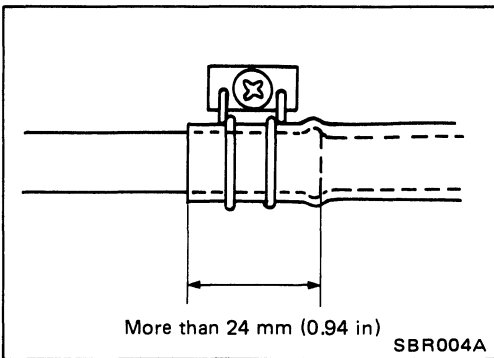
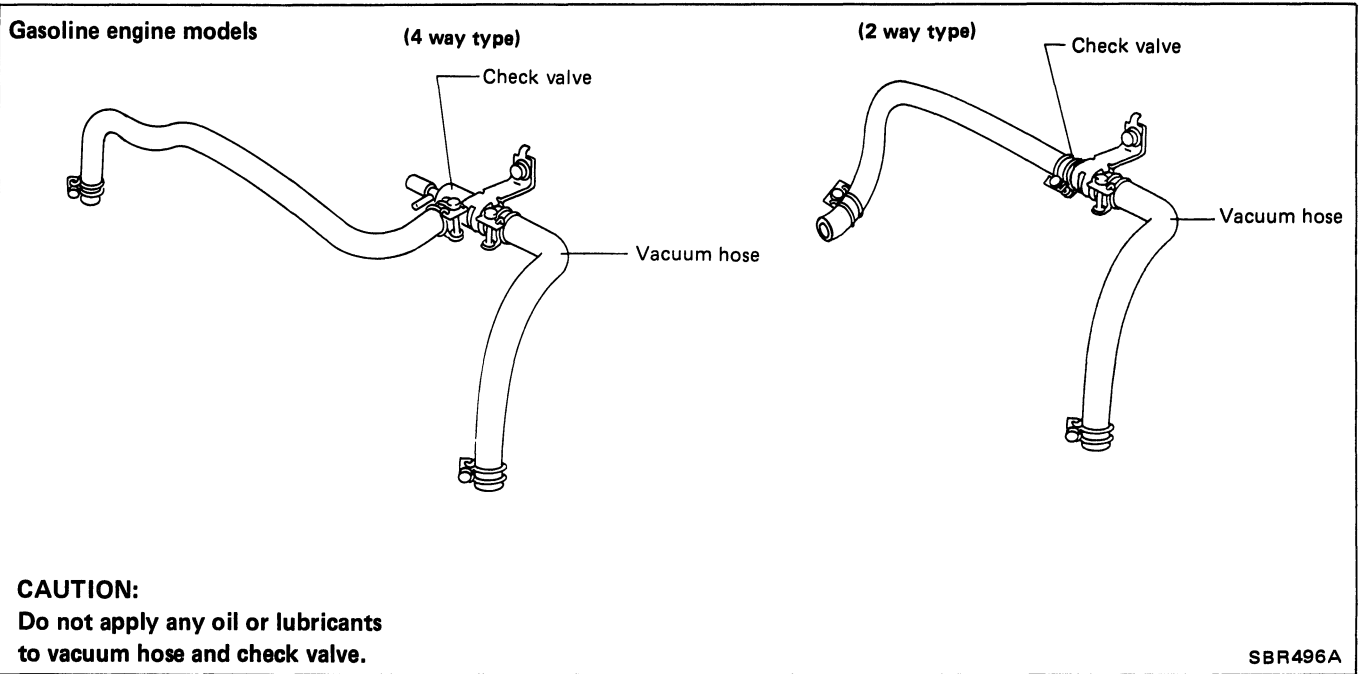

- Insert vacuum tube into vacuum hose more than 24 mm (0.94 in).

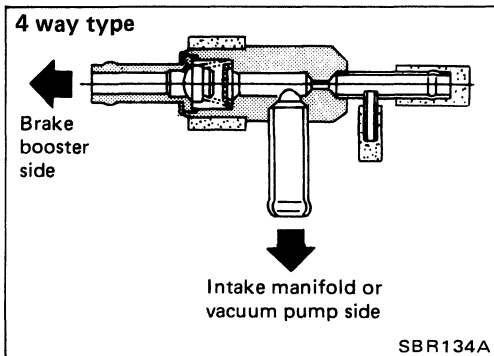

- Install check valve properly paying attention to its direction.

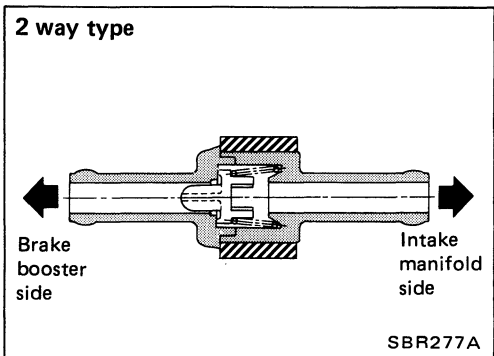

## Wheel Cylinder Inspection

Check parts for score, wear or damage. Replace if any of the above conditions are observed.

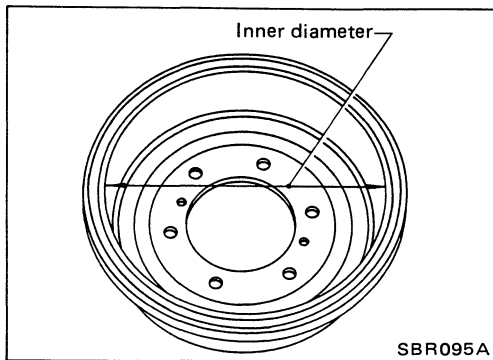
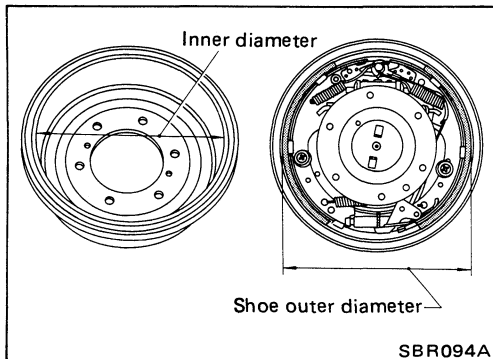

## Removal and Installation of Adjuster

When installing, measure inner diameter of the drum and adjust so that shoe outer diameter at its center is smaller than drum inner diameter by 0.25 to 0.4 mm (0.0098 to 0.0157 in) by rotating the adjuster. Then operate parking brake lever to adjust shoe clearance.

## Drum Inspection

### Standard inner diameter:

DS22	220.0 mm (8.66 in)
DS25B, DS25C	254.0 mm (10.00 in)
LT26B	260.0 mm (10.24 in)

### Maximum inner diameter:

DS22	221.5 mm (8.72 in)
DS25B, DS25C	255.5 mm (10.06 in)
LT26B	261.5 mm (10.30 in)

### Out-of-roundness (ellipticity):

0.03 mm (0.0012 in) or less

### Radial runout (Total indicator reading):

0.05 mm (0.0020 in) or less

- Contact surface should be finefinished with No. 120 to 150 emery paper.
- Using a drum racer, lathe brake drum if it shows score marks, partial wear or stepped wear.
- After brake drum has been completely reconditioned or replaced, check drum and shoes for proper contact pattern.

# SERVICE DATA AND SPECIFICATIONS (S.D.S.)

## General Specifications

	Model	2WD				4WD	4WD and 2WD
	Engine	Z24i		VG30i		VG30i, Z24i	
	Grade	Except STD Regular Bed	STD Regular Bed	Except Heavy Duty Cab & Chassis	Heavy Duty	Truck	Van & Wagon
<b>Front brake</b>							
Brake model		CL28VA		CL28VD			
Pad dimensions Width x thickness x length mm (in)		IN 43 x 11 x 126.5 (1.69 x 0.43 x 4.98) OUT 43 x 11 x 129 (1.69 x 0.43 x 5.08)		48.5 x 10 x 146.6 (1.909 x 0.39 x 5.77)			
Rotor outer diameter	mm (in)	250 (9.84)		260 (10.24)		277 (10.91)	
Cylinder inner diameter	mm (in)	60.6 (2.386)		42.8 (1.685) x 2			
<b>Rear brake</b>							
Brake model		LT26B		DS25B	DS25C	LT26B AD14VB*4 DS19HB*4	
Cylinder inner diameter	mm (in)	22.22 (7/8)		23.81 (15/16)	17.46 (11/16)		20.64 (13/16), 42.83 (1.6862) *4
Lining dimensions Width x thickness x length mm (in)		50 x 5.5 x 249.6 (1.97 x 0.217 x 9.83)		45 x 3.9 x 265.9 (1.77 x 0.154 x 10.47)	60 x 6 x 265.9 (2.36 x 0.24 x 10.47)	50 x 5.5 x 249.6 (1.97 x 0.217 x 9.83), 25.3 x 10 x 100.8 (0.996 x 0.39 x 3.97)*4, 30.0 x 3.0 x 182.3 (1.181 x 0.118 x 7.18)*4	
Drum inner diameter /Rotor outer diameter	mm (in)	260 (10.24)		254 (10.00)		260 (10.24), 286 (11.26)*4, 190 (7.48)*4	
Master cylinder Inner diameter	mm (in)	23.81 (15/16)		25.4 (1)	23.81 (15/16)		
<b>Brake booster</b>							
Model		M20T M195T	G23, M23	M195T, M20T			M195T M215T*4
Diaphragm diameter	mm (in)	Pri 205 (8.07), 205 (8.07)*5 Sec 180 (7.09), 201 (7.91)*5	230 (9.06)	Pri 205 (8.07), 205 (8.07)*5 Sec 180 (7.09), 201 (7.91)*5			Pri 205 (8.07), 230 (9.06)*4 Sec 201 (7.91), 205 (8.07)*4
<b>Control valve</b>							
Type		P.V.*3		L.S.V.*1	L.S.V.*2	P.V.*3	
Split point x Reducing ratio kPa (kg/cm <sup>2</sup> , psi) x ratio		2,452 (25, 356) x 0.1		(Variable) x 0.1	(Variable) x 0.23	1,961 (20, 284) x 0.1	2,942 (30, 427) x 0.2, 3,923 (40, 569) x 0.4*4

\*1: Load sensing valve (A-type)

\*2: Load sensing valve (B-type)

\*3: Proportioning valve (within master cylinder)

\*4: Option as sports package

DS19HB for parking brake

\*5: Model M20T type

## STEERING WHEEL AND STEERING COLUMN

### Removal and Installation (Cont'd)

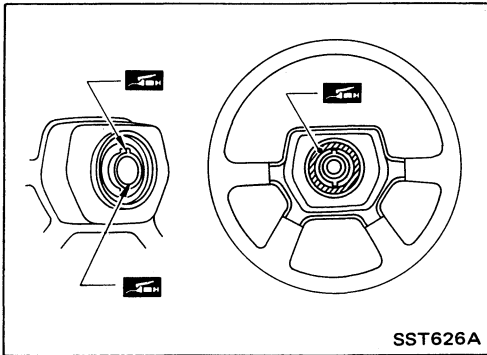

- When installing steering wheel, apply multi-purpose grease to entire surface of turn signal cancel pin (both portions) and also to horn contact slip ring.

- Install steering wheel on column shaft in a straight-ahead position.
- After installing, turn steering wheel to make sure it moves smoothly and that the number of turns from the straight forward position to left and right locks are equal.

### STEERING COLUMN

- When installing steering column, finger-tighten all lower bracket and clamp retaining bolts; then retighten them securely. Make sure that undue stress is not applied to steering column.

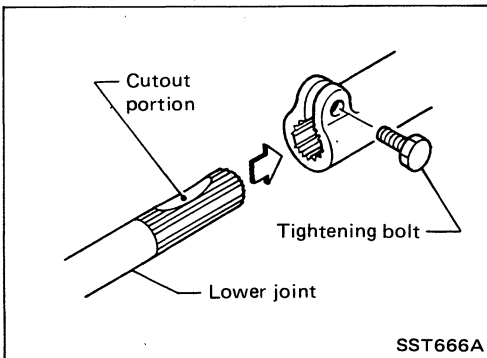

- When fitting steering lower joint, be sure tightening bolt faces cutout portion perfectly.

## POWER STEERING GEAR (Model : PB56S)

### Disassembly (Cont'd)

#### ADJUSTING SCREW LOCK NUT O-RING

Remove adjusting screw lock nut, and replace O-ring.

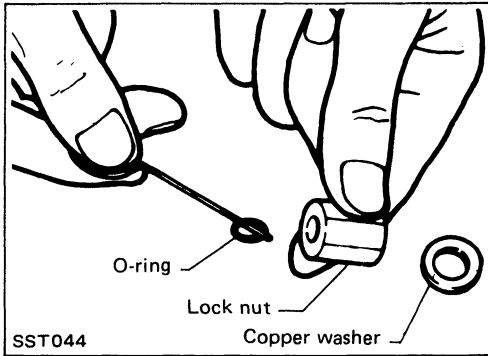

#### SECTOR SHAFT OIL SEAL AND DUST SEAL

1. Set stub shaft in a straight-ahead position.

**Straight-ahead position is a position where stub shaft is turned 2.14 turns (two full turns and 50°) from lock position.**

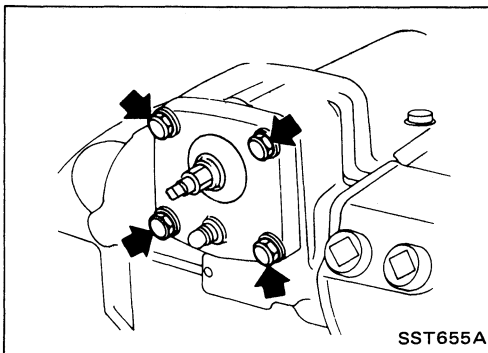

2. Disconnect sector shaft cover bolt.

**Do not turn lock nut unless necessary; otherwise it will damage O-ring, resulting in an oil leak.**

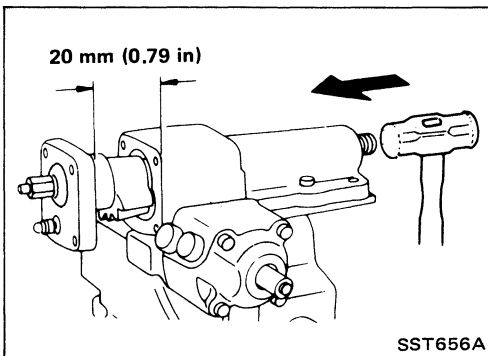

3. Draw out sector shaft.

**Knock out end of sector shaft approximately 20 mm (0.79 in).**

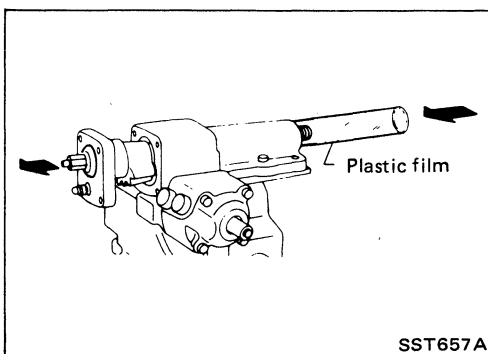

4. Connect a roll of plastic film to sector shaft.

**Plastic film:**

**Thickness 0.1 mm (0.004 in)**

**Length x width**

**200 x 200 mm (7.87 x 7.87 in)**

5. Pull out sector shaft by hand.

**Attach plastic film to needle bearings located at two places inside gear housing while simultaneously pulling out sector shaft so that bearings will not drop into housing.**

# POWER STEERING OIL PUMP

## Models equipped with Z engine

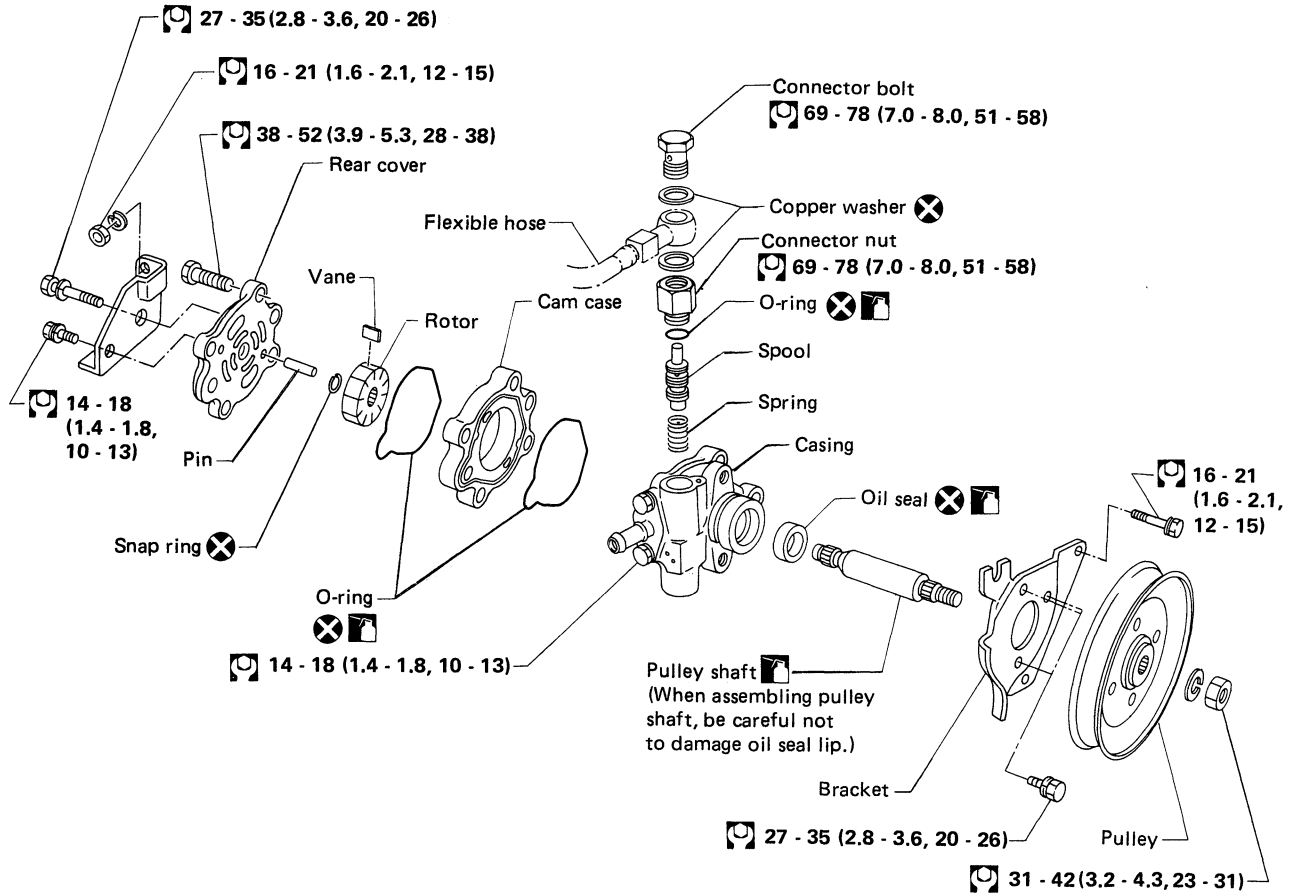

## Models equipped with VG engine

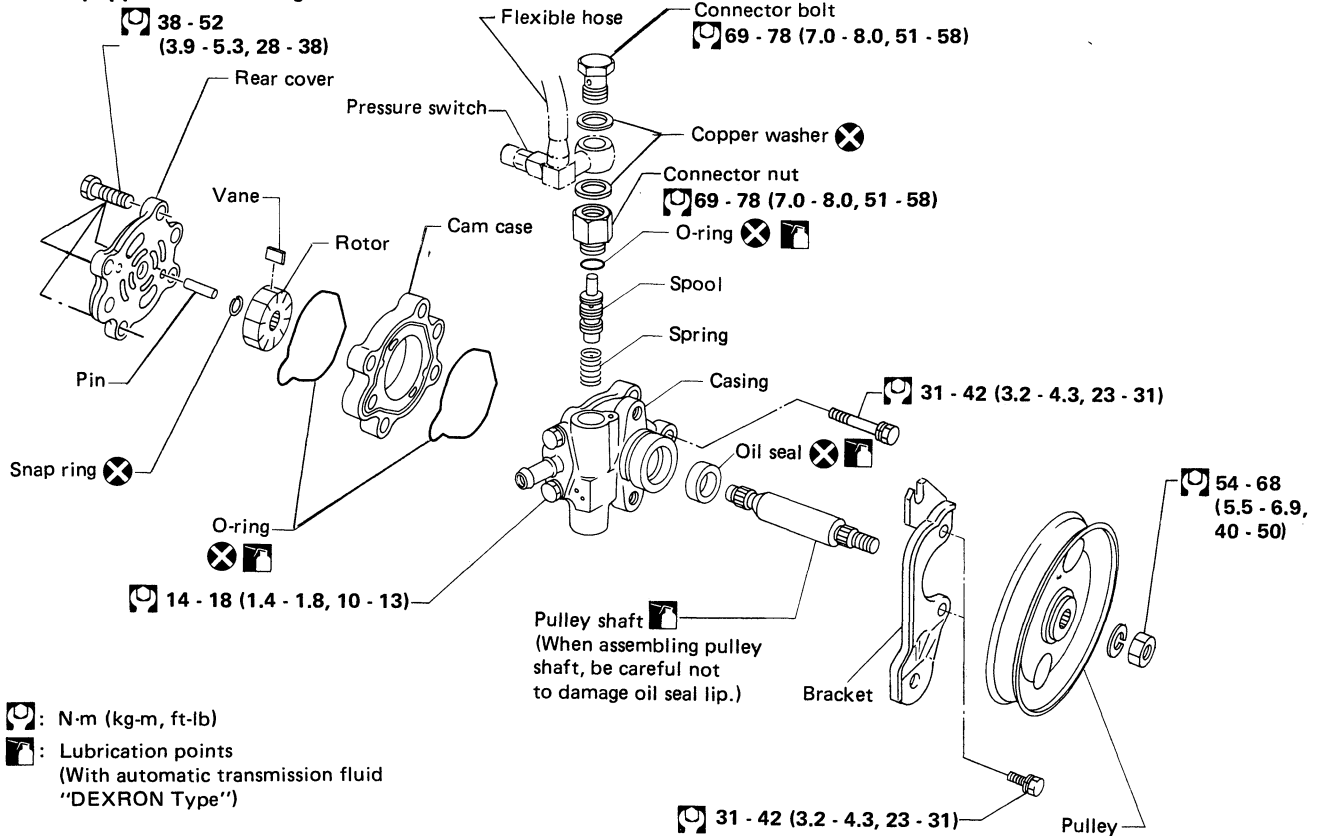

- : N·m (kg-m, ft-lb)
- : Lubrication points (With automatic transmission fluid "DEXRON Type")

SST895A



# GENERAL SERVICING

## Precautions

- When removing or installing various parts, place a cloth or padding onto the vehicle body to prevent scratches.
- Handle trim, molding, instruments, grille, etc. carefully during removing or installation. Be careful not to soil or damage them.
- Apply sealing compound where necessary when installing parts.
- When applying sealing compound, be careful that the sealing compound does not protrude from parts.
- When replacing any metal parts (for example body outer panel, members, etc.), be sure to take rust prevention measures.

## Clip and Fastener

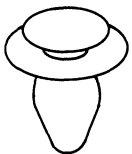
- Clips and fasteners in BF section correspond to the following numbers and symbols.
- Replace any clips and/or fasteners which are damaged during removal or installation.

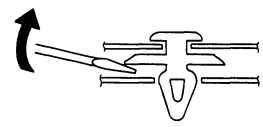
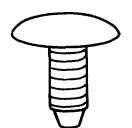
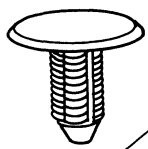
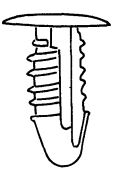
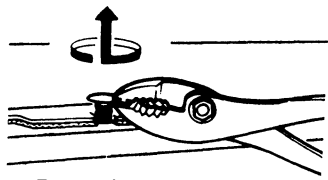
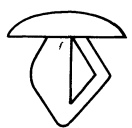
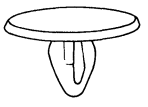
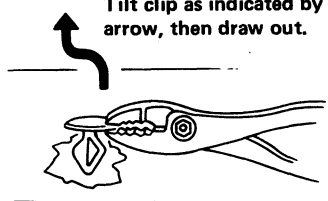
No.	Symbol	Shape	Removal & Installation
C101	 SBF092B	 SBF109B	<p><b>Removal:</b> Remove by bending up with a flat-bladed screwdriver.</p>  SBF094B
C102	 SBF113B	 SBF114B  SBF137B	 <p><b>Removal:</b> Pull up by rotating</p> SBF115B
C105	 SBF141B	 SBF142B	<p><b>Removal:</b> Tilt clip as indicated by arrow, then draw out.</p>  SBF143B

# DOOR

## Power Door Lock (Cont'd)

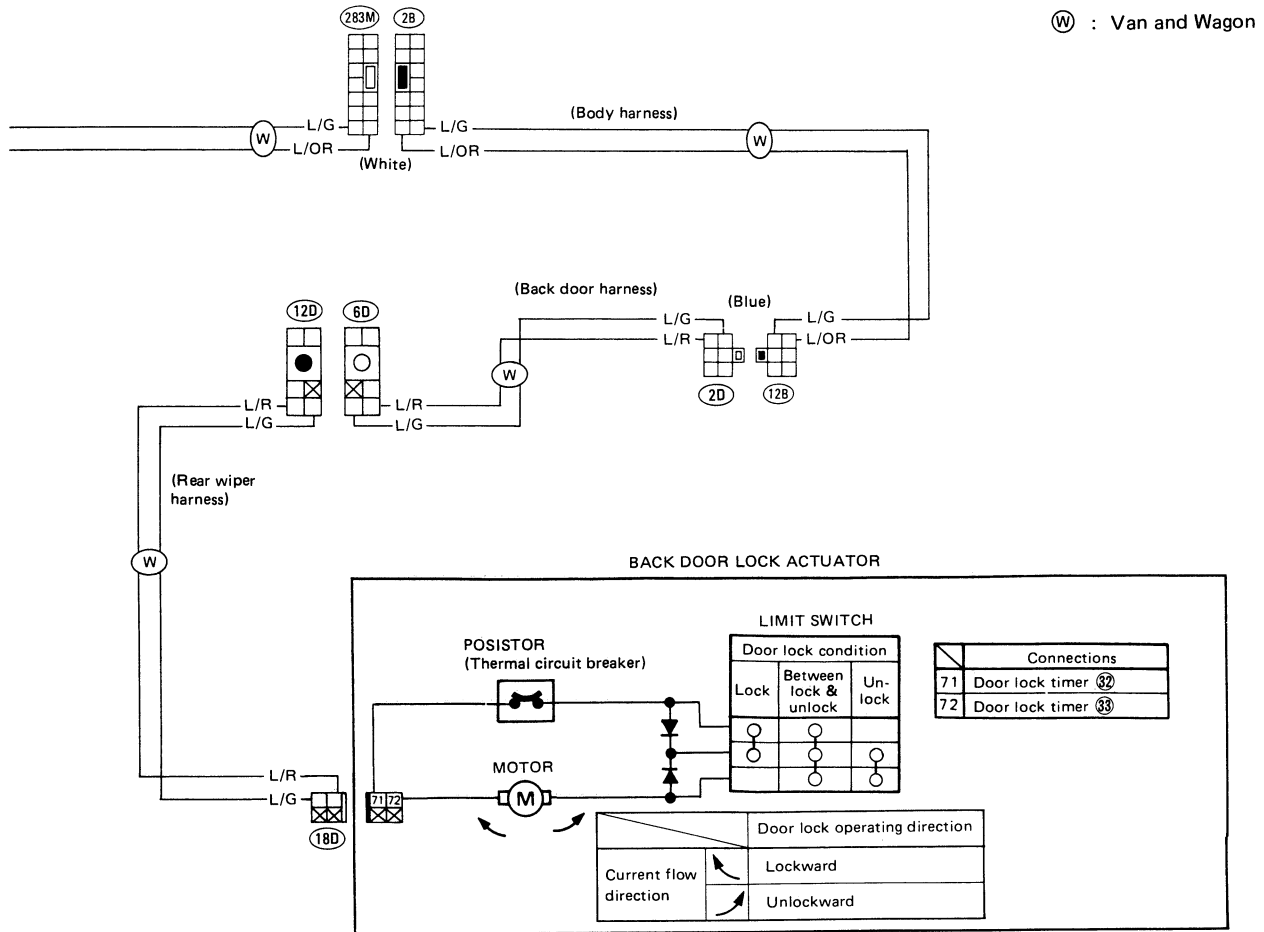
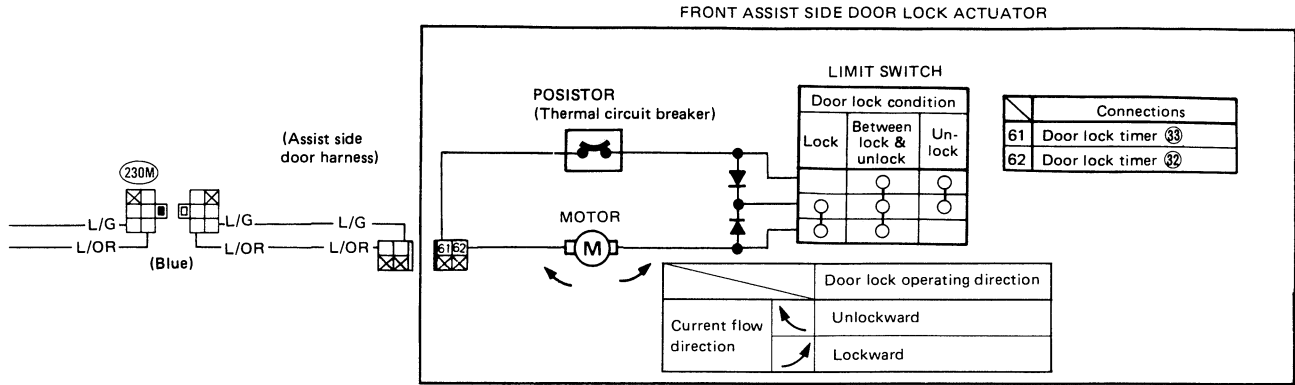

Ⓜ : Van and Wagon

## Exterior—TRUCK (Cont'd)

### 15 Back window

#### I Fixed glass type

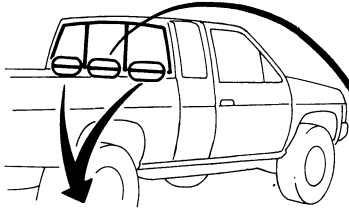
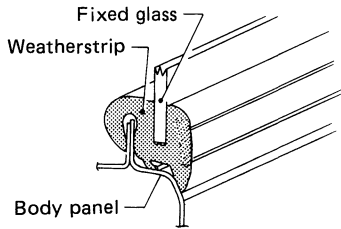

#### II Slide glass type

##### • Fixed glass part

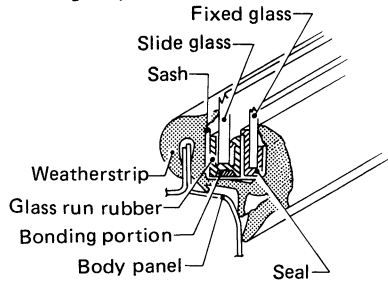

##### • Slide glass part

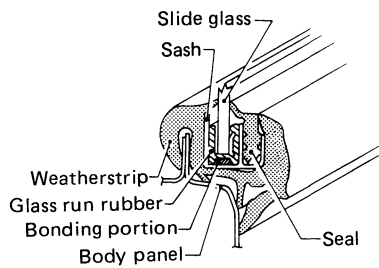

SBF813D

### 16 17 Rear side window weatherstrip and rear side window protector

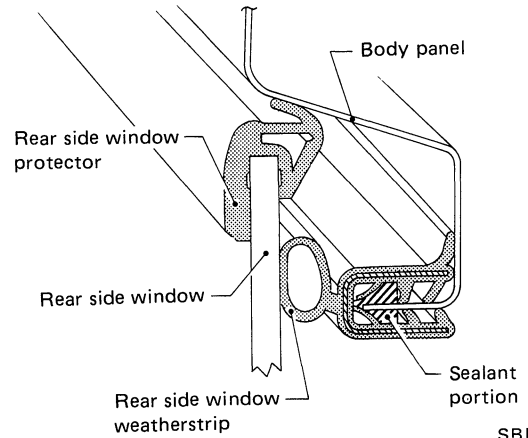

SBF312C

### 18 19 Sun roof weatherstrip and lid protector

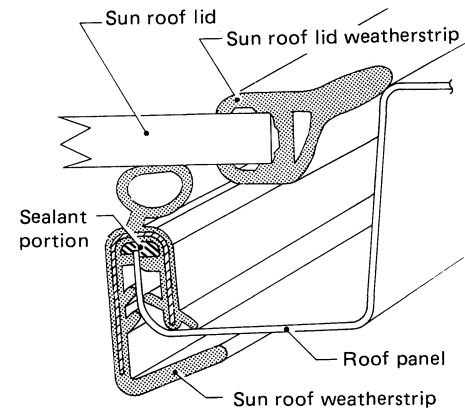

SBF313C

### 20 Rope hook protector

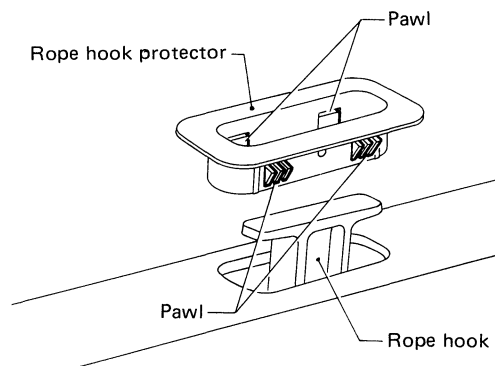

SBF314C

# WINDSHIELD AND WINDOWS

## Rear Side Window—TRUCK

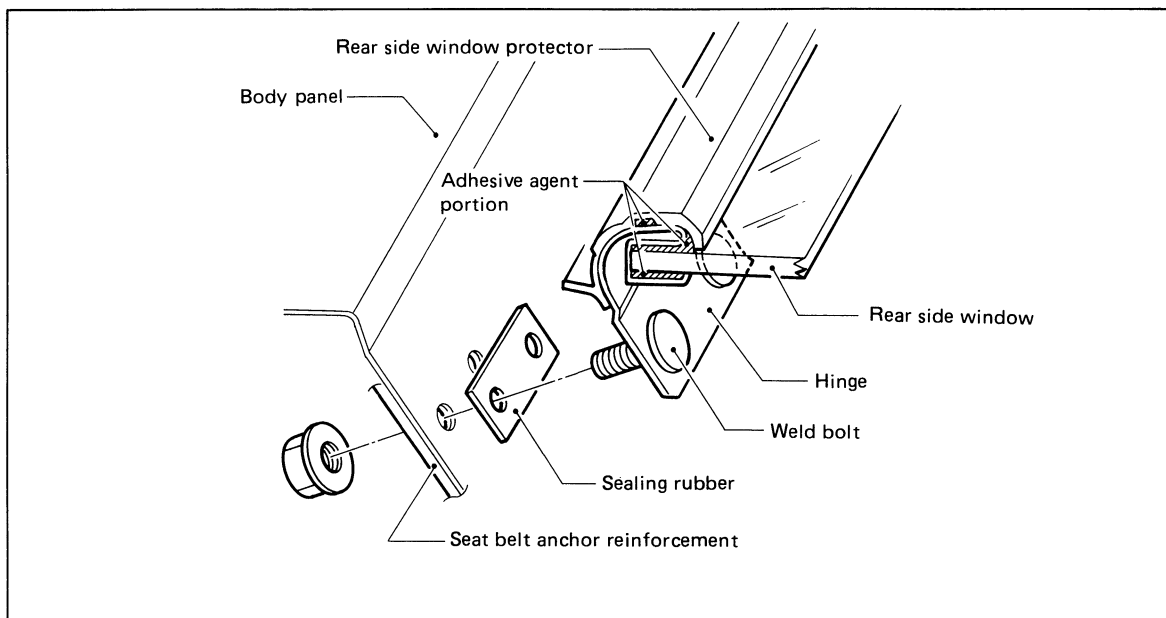
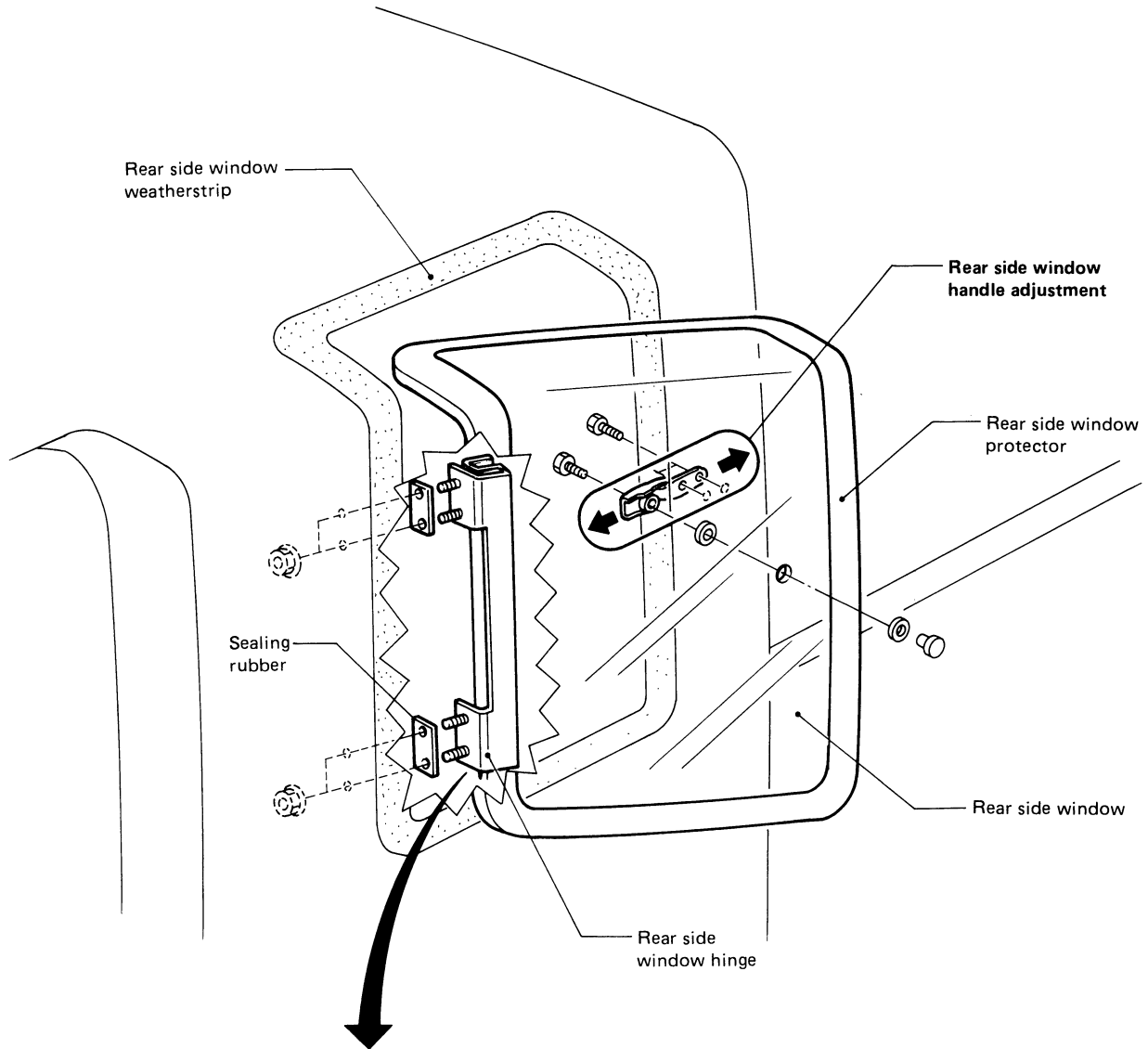

SBF523C

# BODY ALIGNMENT

## Underbody—TRUCK

### MEASUREMENT POINTS

2WD models

- R : Regular Cab
- K : King Cab
- RL : Regular Cab (Long wheelbase)

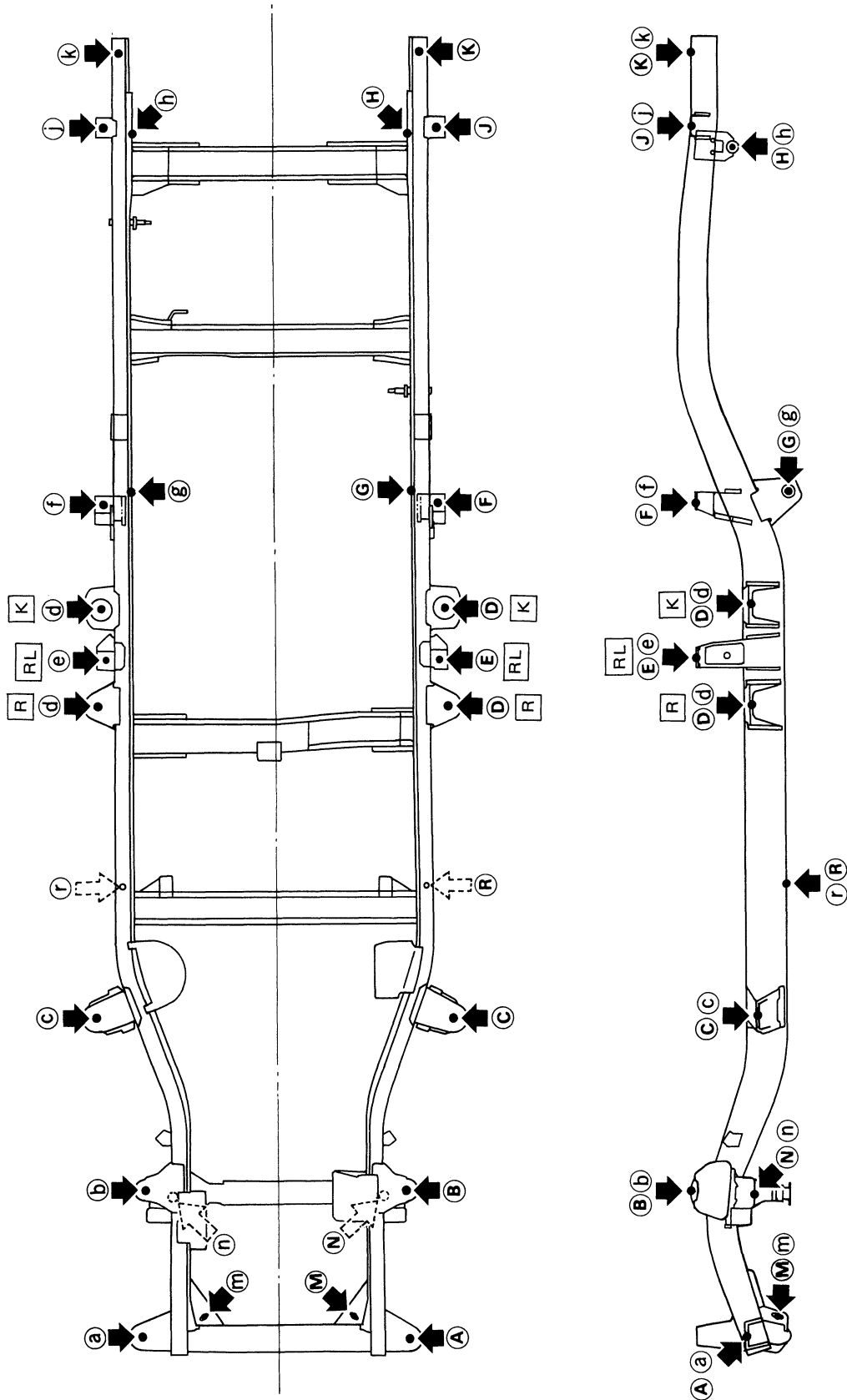

# BODY ALIGNMENT

## Underbody—VAN & WAGON (Cont'd)

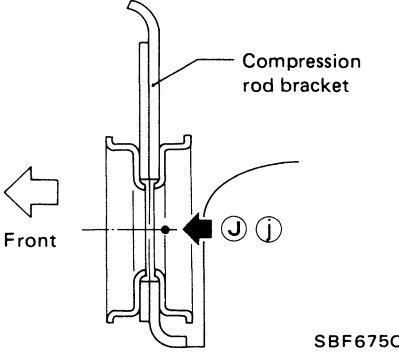
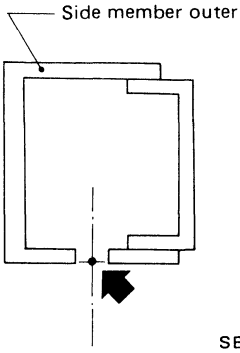
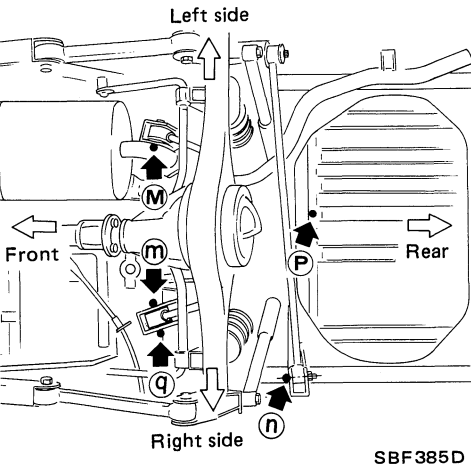
Points	Hole dia. mm (in)	Detailed points	Coordinates mm (in)			
			"x"	"y"	"z"	
ⓐ ⓑ	27 (1.06)	 <p>Compression rod bracket</p> <p>Hole for compression rod mounting at the bracket</p> <p>SBF675C</p>	361.1 (14.22)	294.5 (11.59)	-158.9 (-6.26)	
ⓓ ⓔ	13 (0.51)	 <p>Side member outer</p> <p>Hole for waxing at lower side of side member outer</p> <p>SBF676C</p>	510.0 (20.08)	1,040.0 (40.94)	-135.0 (-5.31)	
ⓕ ⓖ	13 (0.51)		Hole for torque arrester mounting at lower side of side member outer	510.0 (20.08)	2,210.0 (87.01)	17.2 (0.677)
ⓓ ⓔ	14 (0.55)	 <p>Left side</p> <p>Right side</p> <p>Front</p> <p>Rear</p> <p>SBF385D</p>	268.0 (10.55)	2,381.6 (93.76)	5.0 (0.197)	
ⓖ ⓗ	14 (0.55)		Hole for upper link mounting at the bracket	332.0 (13.07)	2,396.4 (94.35)	5.0 (0.197)
ⓓ	14 (0.55)		Hole for panhard rod mounting at front portion of the bracket	496 (19.53)	2,840.5 (111.83)	-55 (-2.17)
ⓕ	11 (0.43)		Hole for fuel tank mounting at vehicle center	0.0 (0.00)	2,878.0 (113.31)	106.0 (4.17)

# DISCHARGING, EVACUATING, CHARGING AND CHECKING

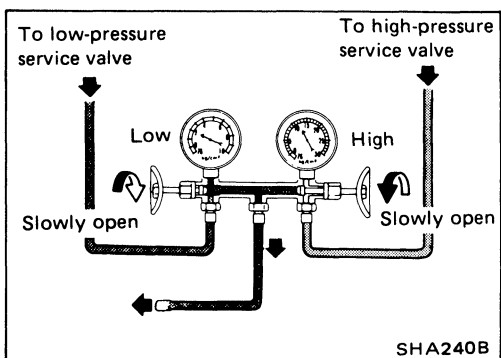

## Discharging—Point-1

Slowly open the valves to discharge only refrigerant. If they are opened quickly, compressor oil will also be discharged.

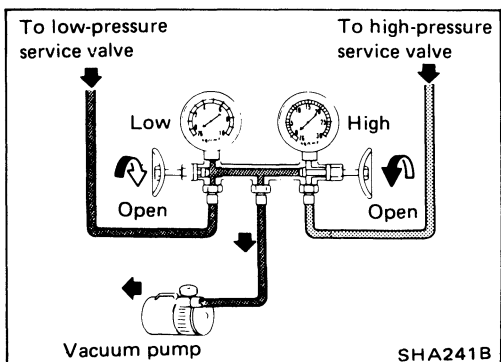

## Evacuating the System—Point-2

1. Start pump, then open both valves and run pump for about 5 minutes.
2. When low gauge has reached approx. 101.3 kPa (760 mmHg, 29.92 inHg), completely close both valves of gauge and stop vacuum pump. Let it stand for 5 to 10 minutes in this state and confirm that the reading does not rise.
  - a. The low-pressure gauge reads lower by 3.3 kPa (25 mmHg, 0.98 inHg) per 300 m (1,000 ft) elevation. Perform evacuation according to the following table.
  - b. The rate of ascension of the low-pressure gauge should be less than 3.3 kPa (25 mmHg, 0.98 inHg) in 5 minutes.

Elevation m (ft)	Vacuum of system* kPa (mmHg, inHg)
0 (0)	101.3 (760, 29.92)
300 (1,000)	98.0 (735, 28.94)
600 (2,000)	94.6 (710, 27.95)
900 (3,000)	91.3 (685, 26.97)

\*: Values show reading of the low-pressure gauge.

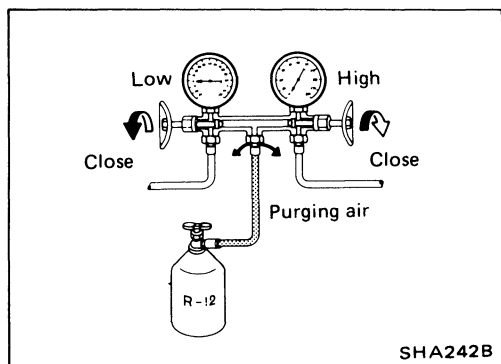

## Charging—Point-3

1. Evacuate refrigerant system.  
Refer to "Point-2".
2. Close manifold gauge valves securely and disconnect charging hose from vacuum pump.
3. Purge air from center charging hose.
  - 1) Connect center charging hose to refrigerant can through charge valve.
  - 2) Break seal of refrigerant can and purge air.

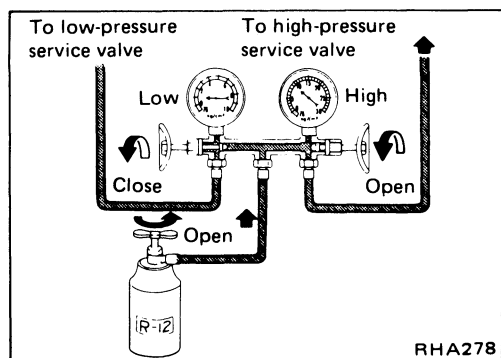

4. Charge refrigerant into system.

### WARNING:

Ensure that engine is off.

- 1) Open high-pressure valve of manifold gauge and charge refrigerant into system.

**Checking and Adjusting (Cont'd)**

2. Check the purity of the oil and then adjust oil level following the procedure below.

(a) When oil is clean;

Unit: ml (US fl oz, Imp fl oz)

Amount of oil drained from used compressor	Draining amount of oil from new compressor
Above 70 (2.4, 2.5)*	200 (6.8, 7.0) – [Amount of oil drained + 20 (0.7, 0.7)]
Below 70 (2.4, 2.5)	110 (3.7, 3.9)

\*: If amount of oil drained is greater than under normal circumstances, flush air conditioner system with refrigerant. Then install new compressor [200 ml (6.9 US fl oz, 7.0 Imp fl oz) of oil is charged in compressor service parts.]

**Example:** Unit: ml (US fl oz, Imp fl oz)

Amount of oil drained from used compressor	Draining amount of oil from new compressor
90 (3.0, 3.2)	90 (3.0, 3.2)
50 (1.7, 1.8)	110 (3.7, 3.9)

(b) When oil contains chips or foreign material; After air conditioner system has been flushed with refrigerant, replace receiver drier. Then install new compressor [200 ml (6.8 US fl oz, 7.0 Imp fl oz) of oil is charged in compressor service parts.] .

# HARNESS CONNECTOR

## Description

### HARNESS CONNECTOR

- All harness connectors prevent accidental looseness or disconnection.
- The connector can be disconnected by pushing or lifting the locking section.

#### CAUTION:

Do not pull the harness when disconnecting the connector.

[Example]

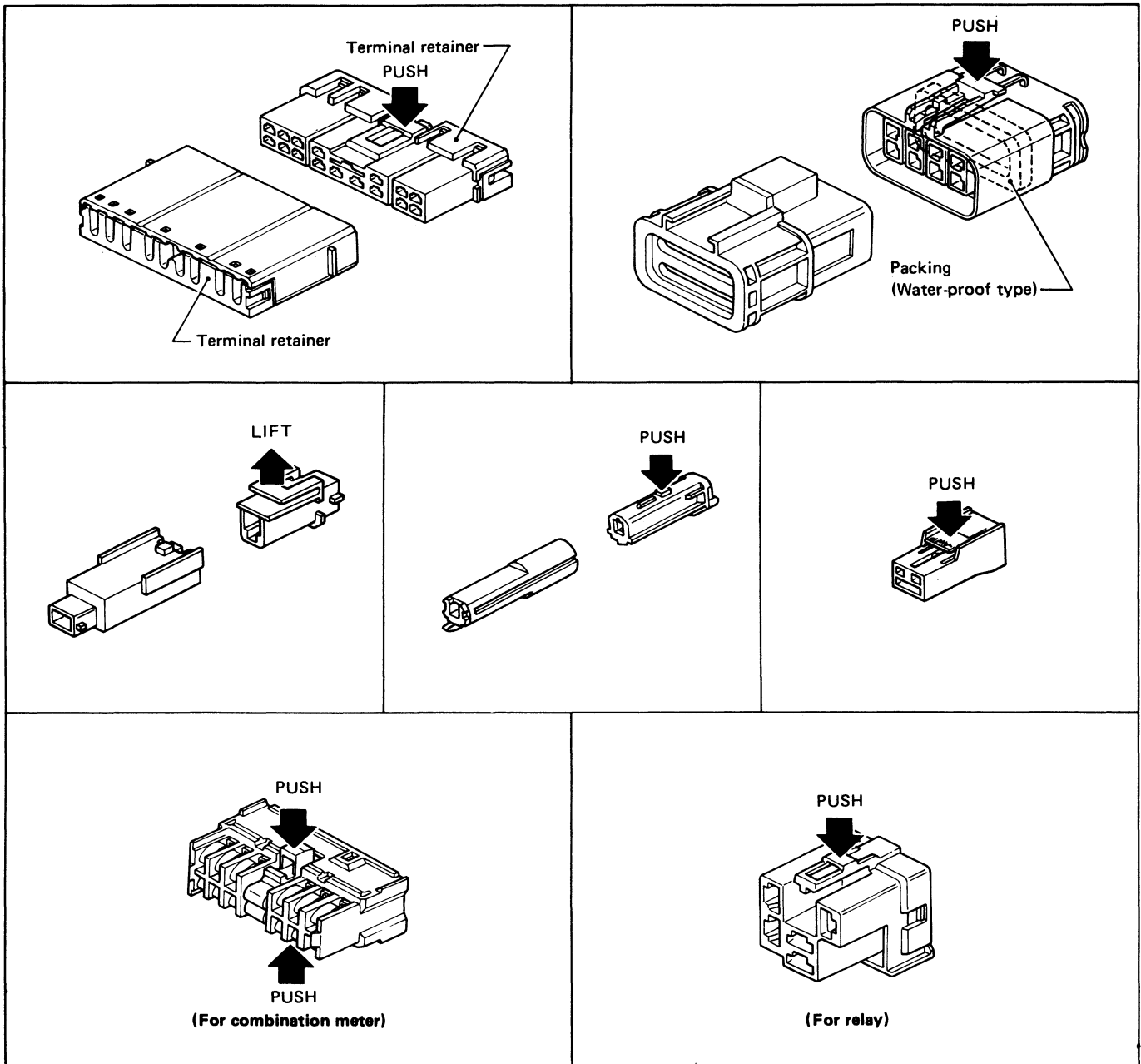

SEL769D

# STARTING SYSTEM

## Schematic

### 4-WHEEL DRIVE MODEL

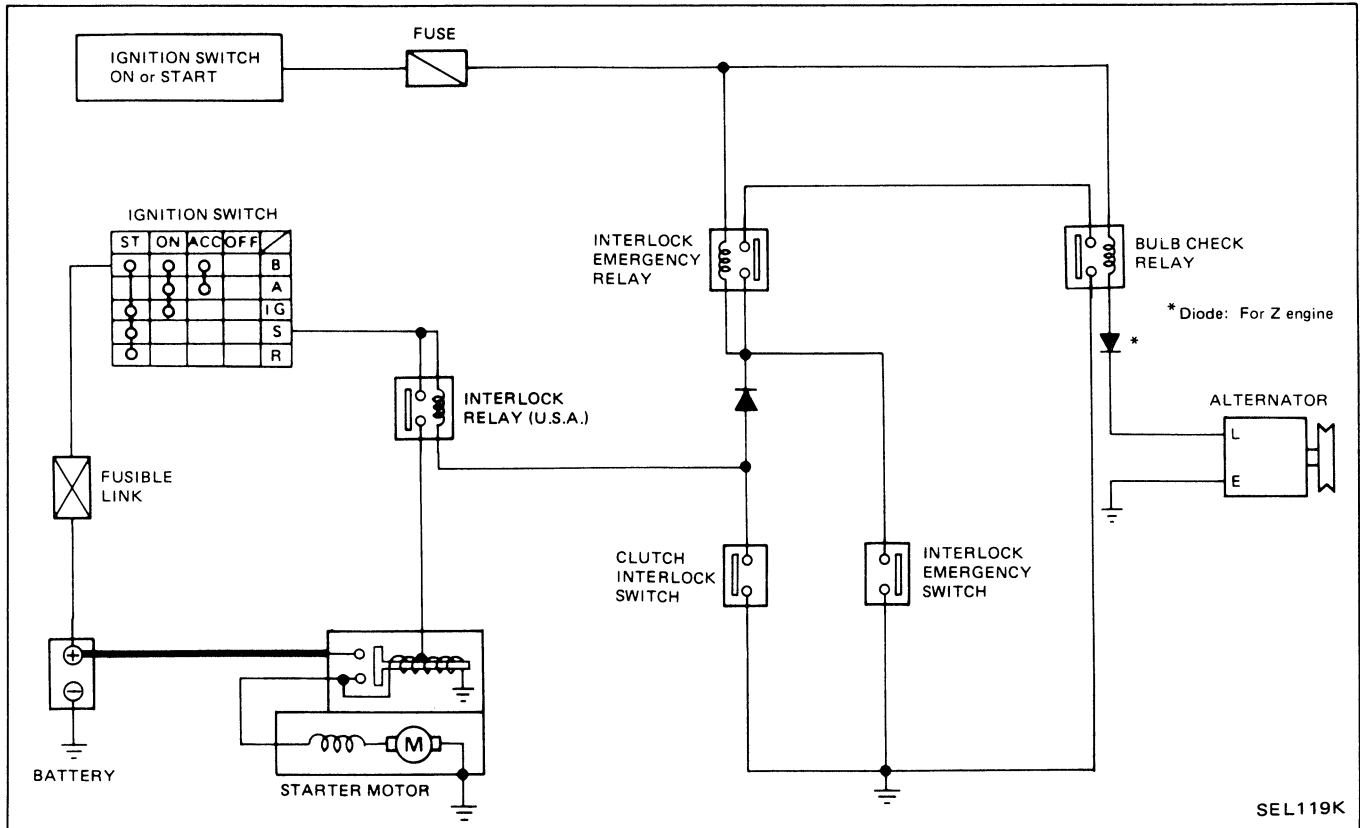

# STARTING SYSTEM —Starter—

## Assembly (Cont'd)

- Not in the specified value ... Adjust with adjusting plate.

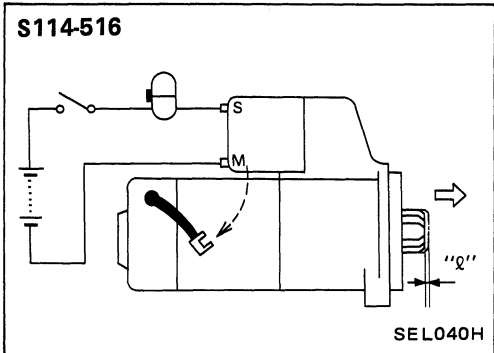
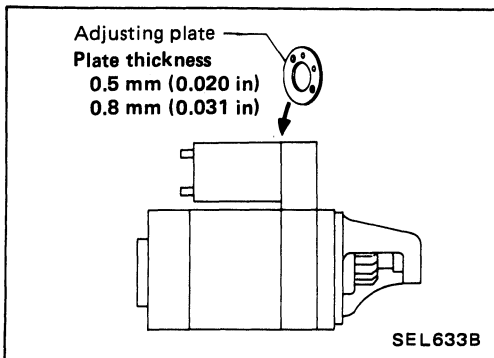

### S114-516, -453 and -454

Measure movement "q" in height of pinion when pinion is pushed out with magnetic switch energized and when pinion is pulled out by hand until it touches stopper.

**Movement "q":**

**Refer to Service Date and Specifications.**

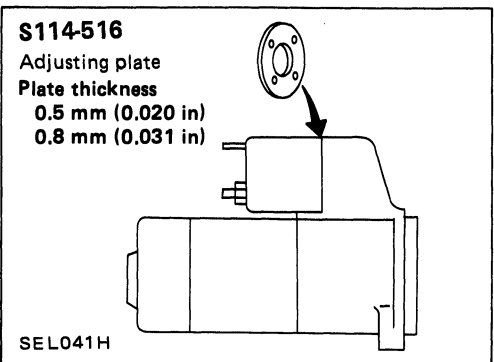
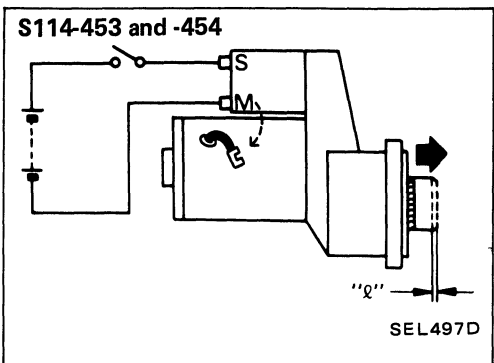

- Not in the specified value ... Adjust with adjusting plate.

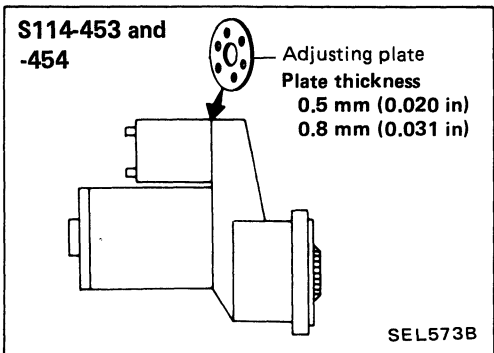

CLICK HERE TO **DOWNLOAD** THE COMPLETE MANUAL

- Thank you very much for reading the preview of the manual.
- You can download the complete manual from: [www.heydownloads.com](http://www.heydownloads.com) by clicking the link below



- Please note: If there is no response to CLICKING the link, please download this PDF first and then click on it.

CLICK HERE TO **DOWNLOAD** THE COMPLETE MANUAL