

FOREWORD

This manual contains maintenance and repair procedures for Nissan FORKLIFT, model 1F1 and 1F2 series.

In order to assure your safety and the efficient functioning of the lift truck, this manual should be read thoroughly. It is especially important that the PRECAUTIONS in the GI section be completely understood before starting any repair task.

All information in this manual is based on the latest product information at the time of publication. The right is reserved to make changes in specifications and methods at any time without notice.

This SERVICE MANUAL does not include the information for GASOLINE and DIESEL engines.

For repair procedure and maintenance of GASOLINE and DIESEL engines, please refer to the following SERVICE MANUAL.

- NISSAN FORKLIFT

SERVICE MANUAL & TECHNICAL BULLETIN GASOLINE ENGINE

(Pub. No. SM3EL - K2125)

SERVICE MANUAL & TECHNICAL BULLETIN DIESEL ENGINE

(Pub. No.)

IMPORTANT SAFETY NOTICE

The proper performance of service is essential for both the safety of the technician and the efficient functioning of the lift truck.

The service methods in this Service Manual are described in such a manner that the service may be performed safely and accurately.

Service varies with the procedures used, the skills of the technician and the tools and parts available. Accordingly, anyone using service procedures, tools or parts which are not specifically recommended by NISSAN must first completely satisfy himself that neither his safety nor the lift truck's safety will be jeopardized by the service method selected.

NISSAN MOTOR CO., LTD.

Industrial Machinery Division

Engineering Department

Tokyo, Japan

CLICK HERE TO **DOWNLOAD** THE COMPLETE MANUAL

- Thank you very much for reading the preview of the manual.
- You can download the complete manual from: www.heydownloads.com by clicking the link below



- Please note: If there is no response to CLICKING the link, please download this PDF first and then click on it.

CLICK HERE TO **DOWNLOAD** THE COMPLETE MANUAL

HOW TO USE THIS MANUAL

- Do not reuse brake fluid that has been removed.
- After repairing the hydraulic or brake system, closely inspect for leakage.
- Do not recklessly release waste oil following an oil change, or treated oil used for parts. Dispose according to the method established by law.
- Before performing maintenance, disconnect the battery ground cable and battery positive (+) cable.
- If, with electronic control specifications, a part is to be welded to a unit later on, disconnect both of the battery cables (+ and -) before welding. (This action prevents current from circling into the ECM.)

PRECAUTIONS RELATED TO ELECTRICAL SYSTEM INSPECTIONS

- Do not pry connectors when inserting or withdrawing them. Such actions can cause poor contact.
- When withdrawing a connector, do not pull on the wire (cable) itself.
- When conducting an inspection with a circuit tester, use the correct range (A, V, Ω) and polarity (+, -).
- When the task is completed, reconfirm that the wiring is connected in its original location.

PRECAUTIONS RELATED TO BATTERY HANDLING



WARNING:

- **Keep sources of fire away from batteries.**
- **To keep from getting burned, do not allow battery fluid to get on your skin or clothing.**
- **If a large amount of battery fluid spills or leaks out, immediately neutralize it with a neutralizing agent (such as baking soda, calcium hydroxide, or sodium carbonate) and wash it away with a large amount of water.**
- **Do not leave tools or other metal objects on the battery, because contact with a terminal can cause a short, burning anyone nearby, or hydrogen gas emitted from the battery can ignite and explode.**
- **If static electricity is produced, a battery can explode. Therefore, do not wipe or dust off the battery's top surface or terminal areas with a dry cloth or duster, and do not cover with a vinyl cover. Use a damp cloth to clean the battery.**



CAUTION:

- **Leaking battery fluid can cause corrosion, therefore, securely close the battery fluid cap.**
- **Do not allow a person to inspect a battery if that person does not understand how to properly handle batteries.**

MAINTENANCE

SECTION **MA**

CONTENTS

LUBRICATION CHART	MA-2	BATTERY	MA-20
Lubrication Schedule Chart	MA-2	Inspection of Battery Fluid Level	MA-20
Grease and Oil Capacity	MA-3	Inspection of Specific Gravity of Battery Fluid	MA-20
MAINTENANCE SCHEDULE	MA-4	TIRES AND ROAD WHEELS	MA-21
Periodic Maintenance and Lubrication Schedule for Emission Control System Maintenance	MA-4	Tire Air Pressure and Specifications	MA-21
Chassis and Body Maintenance	MA-5	Inspection of Tire for Wear	MA-21
ENGINE MAINTENANCE	MA-6	Inspection of Wheel Nut	MA-22
Inspection of Cylinder Head Tightening	MA-6	BRAKE SYSTEM	MA-23
Inspection of Manifold Tightening	MA-6	Inspection of Brake Fluid Level	MA-23
Inspection/Adjustment of Valve Clearance	MA-7	Inspection/Adjustment of Brake Pedal	MA-23
Inspection of Compression Pressure	MA-8	HYDRAULIC SYSTEM	MA-24
Inspection/Adjustment of Fan Belt	MA-10	Hydraulic Test	MA-24
Inspection of Engine Oil Level	MA-10	LOADING MECHANISM	MA-25
Replacement of Engine Oil	MA-11	Inspection of Fork	MA-25
Replacement of Engine Oil Filter	MA-11	Inspection/Adjustment of Carriage Height	MA-25
Inspection of Coolant Level	MA-12	Inspection/Adjustment of Lift Chain Tension	MA-25
Replacement of Coolant	MA-13	Inspection of Carriage Roller	MA-26
Inspection of Radiator	MA-13	Inspection of Mast Roller	MA-26
Inspection of Radiator Cap	MA-14	Adjustment of Mast Roller Clearance	MA-27
Inspection/Replacement of Fuel Filter	MA-14	Inspection of Mast Operation	MA-29
Bleeding Fuel System	MA-15	Inspection of Mast Cylinder	MA-29
Inspection/Adjustment of Injection Pressure for Fuel Injection Nozzle (QD32 Engine)	MA-16	Inspection of Tilt Cylinder	MA-29
Inspection/Adjustment of Fuel Injection Timing (QD32 Engine)	MA-17	Greasing Point	MA-29
Tar Extraction from Vaporizer (Combined Use of Gasoline/LPG)	MA-18	BODY ELECTRICAL	MA-31
Inspection/Adjustment of Maximum rpm Under Loaded and Unloaded Conditions	MA-18	Inspection/Replacement of Fuses	MA-31
Inspection of Spark Plug (K21 and K25 Engines)	MA-19	Replacement of Bulbs	MA-32

NOTE: This section contains information and specifications for both carbureted general overseas market models, as well as, electronic control models (manufactured in USA.) Therefore, ensure the specifications or procedures you are looking at are for the proper fuel delivery system; electronic controlled or carbureted.

Replacement of Engine Oil



CAUTION:

- **Before replacing the engine oil, ensure that the engine oil is sufficiently cooled down. The engine oil is hot just after the engine is stopped.**
 - **Wipe away any spilt oil. Spilt oil may cause a fire.**
1. Open the engine hood.
 2. Remove the oil filler cap.
 3. Place an appropriate container under the oil pan. Remove the drain plug and extract the engine oil.
 4. After all engine oil is extracted, install the drain plug and tighten it to the specified torque.

Unit: N•m (kg-m, ft-lb)

Engine	Tightening torque
K21, K25	29.4 - 39.2 (3.0 - 4.0, 22 - 29)
QD32	54 - 59 (5.5 - 6.0, 40 - 44)

5. If the oil filter requires replacement, replace it referring to the next procedure.
6. Add the engine oil through the oil filler

Unit: 2 (US gal, Imp gal)

Engine	Capacity
K21, K25	3.8 (1, 7/8)
QD32	7.2 (1-7/8, 1-5/8)

7. After filling the engine with engine oil, check the engine oil level with the engine oil level gauge. Adjust the oil level if necessary.
8. Install the oil filler cap. Start the engine and allow the engine to idle.
9. Stop the engine and wait for 10 minutes or more until the oil level stabilizes. Then check the oil level again and adjust the level if necessary.

Replacement of Engine Oil Filter



CAUTION:

- **Before replacing the engine oil filter, ensure that the engine oil is sufficiently cooled down. The engine oil is hot just after the engine is stopped.**
 - **Wipe away any spilt oil. Spilt oil may cause a fire.**
1. Remove the oil filter with an oil filter wrench.
 2. Apply a thin coat of engine oil to the oil seal face of a new oil filter.

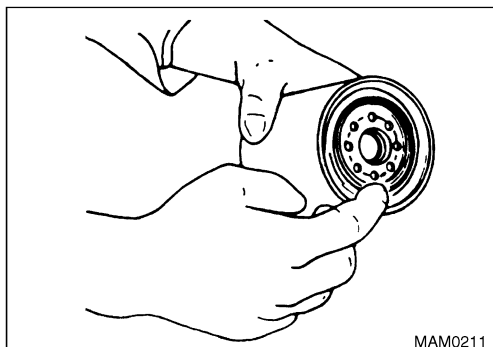

MAM0211

TIRES AND ROAD WHEELS

Tire Air Pressure and Specifications

Measure the tire air pressure to see if the correct tire air pressure is maintained.

- CAUTION:**
- Always check the tire air pressure when the tires are cooled down.
 - After measurement, make sure to attach the tire valve caps.

Unit: kPa (bar, kg/cm², psi)

Vehicle	Front tire (drive)	Tire pressure
1.5 ton, 1.8 ton, 2.0 ton	6.50-10/10PR	700 (6.9, 7.0, 102)
2.0 ton, 2.5 ton, 2.75 ton	7.00-12/12PR	700 (6.9, 7.0, 102)
2.8 ton, 3.0 ton	28x9-15/12PR	700 (6.9, 7.0, 102)
3.5 ton	250-15/16PR	700 (6.9, 7.0, 102)
A1F1 1.5 ton, 1.8 ton	6.00-9/12PR	1000 (9.8, 10.0, 145)
A1F2	21x8-9/14PR	900 (8.8, 9.0, 128)
Vehicle	Rear tire (steer)	Tire pressure
1.5 ton, 1.85 ton, 2.0 ton	5.00-8/8PR	700 (6.9, 7.0, 102)
2.0 ton, 2.5 ton, 2.75 ton	6.00-9/10PR	700 (6.9, 7.0, 102)
2.8 ton, 3.0 ton	6.50-10/10PR	700 (6.9, 7.0, 102)
3.5 ton	6.50-10/12PR	900 (8.8, 9.0, 128)
A1F1 1.5 ton, 1.8 ton	5.00-8/8PR	700 (6.9, 7.0, 102)
A1F2	18x7-8/14PR	900 (8.8, 9.0, 128)

Inspection of Tire for Wear

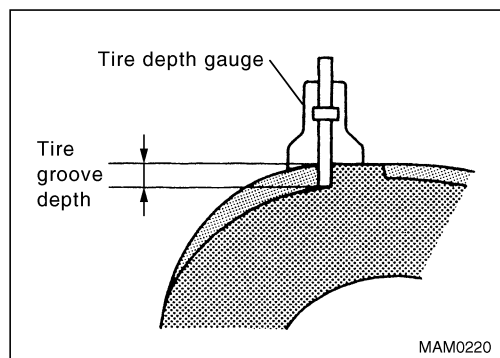

1. Inspect the remaining depth of the tire grooves. Check the tires for tread wear, or measure the depth of the tire grooves with a tire depth gauge.

Repair limit:

5 mm (0.197 in)

2. If any of the tires show a sign of tread wear or the groove depth is less than the above limit, replace the tire.
3. Inspect the tires for uneven wear referring to the table below. If uneven wear is found, identify the causal factor and take appropriate actions. Replace the tire if necessary

Uneven wear	Major cause	Corrective action
Wear at edges 	<ul style="list-style-type: none"> • Insufficient air pressure • Abrupt turning when loaded • Excessive load 	<ul style="list-style-type: none"> • Adjust tire air pressure. • Restrict load.
Central wear 	<ul style="list-style-type: none"> • Excessive air pressure • Skidding during braking 	<ul style="list-style-type: none"> • Adjust tire air pressure.
Single-sided wear 	<ul style="list-style-type: none"> • Uneven braking effect 	<ul style="list-style-type: none"> • Adjust brake or replace lining.
Jagged wear 	<ul style="list-style-type: none"> • Insufficient air pressure 	<ul style="list-style-type: none"> • Adjust tire air pressure.

MAM0221

Measurement points for fork wear

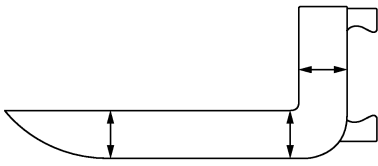

LMM0227

Inspection of Fork

1. Visually inspect the fork and replace it if cracked or damaged. (To identify minute cracks, use the dye penetrant method.)
2. If the fork is worn by 3 mm (0.12 in) or more compared to a new one, replace it. (The grounding face at the fork base is prone to wear.)

BODY ELECTRICAL

Inspection/Replacement of Fuses

Check and replace the fuses as necessary by referring to the figure on the left.

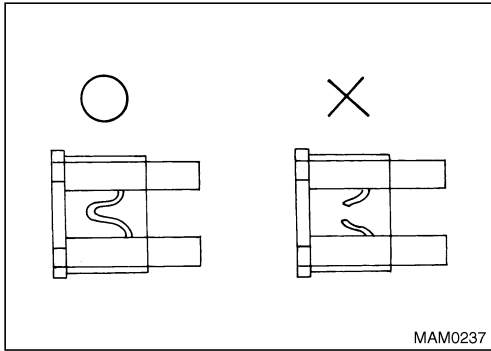

MAM0237

- CAUTION:**
- When installing a new fuse, always use the one with the specified capacity referring to the fuse box label.
 - If the replaced fuse is burnt again, the electrical system is considered to have malfunctions. Immediately identify and remove any causal factors.

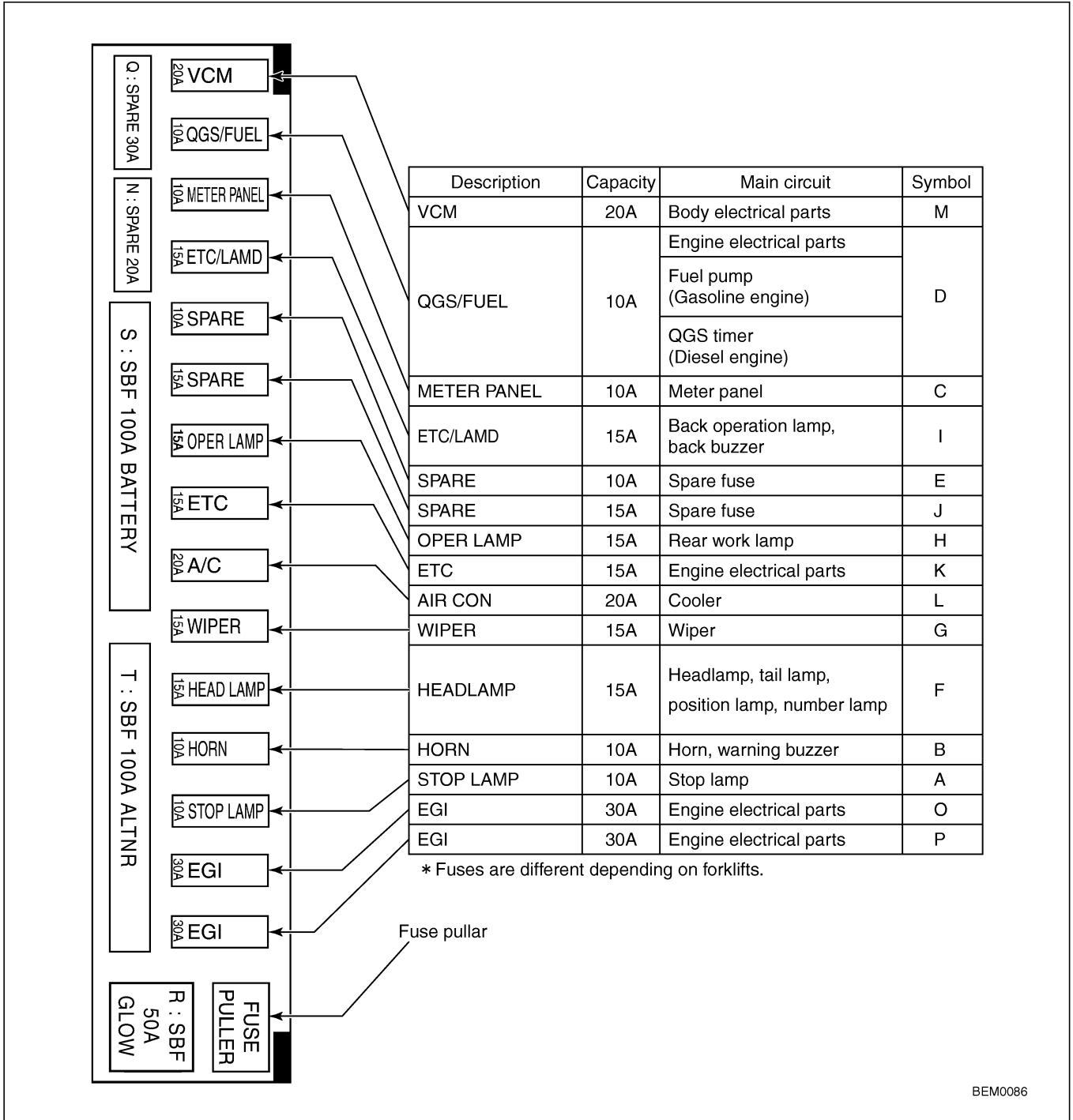

BEM0086

REMOVAL AND INSTALLATION

(7) Engine and Transmission Assembly

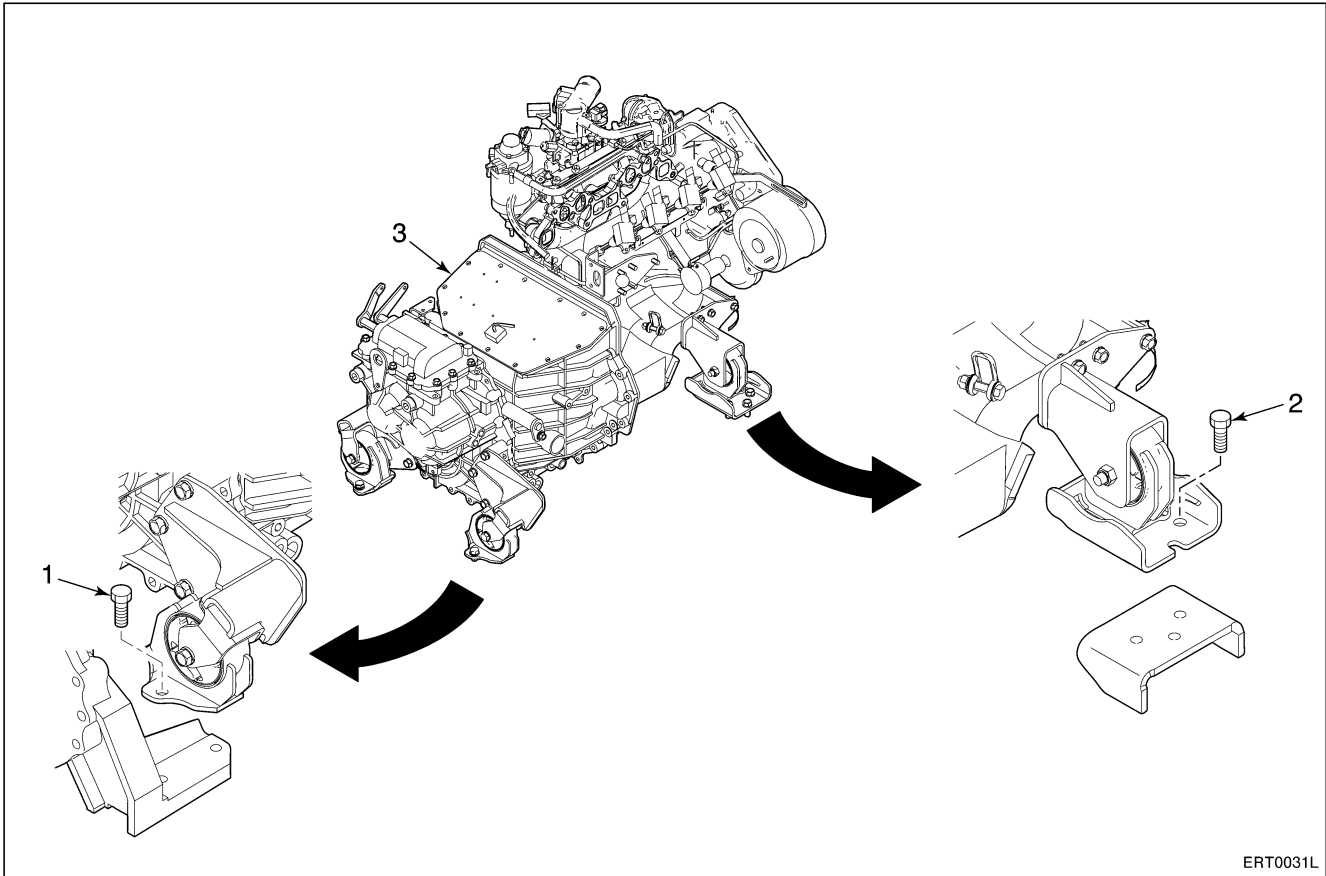

ERT0031L

Order of removal

1. Transmission mount bolt
2. Engine mount bolt
3. Engine and transmission assembly

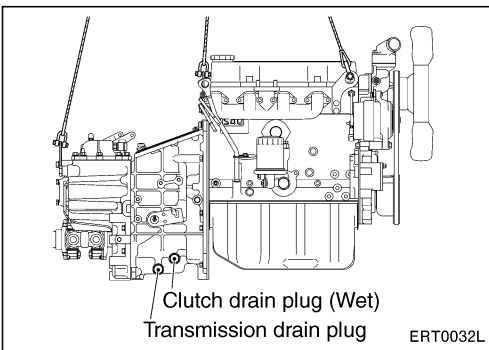

Preparation work

- Attach wire rope to the engine and transmission assembly, and then hoist up with a crane.



CAUTION:

- **Make sure that the chain (wire) has sufficient strength.**
- Remove the engine and transmission (as a unit) from the chassis.

Gross weight of engine transmission (pneumatic only)

Engine model	Gross weight (kg, Lbs.)
K21	360, 794
K25	391, 862
QD32	

3. MECHANISMS AND FUNCTIONS OF CLUTCHES

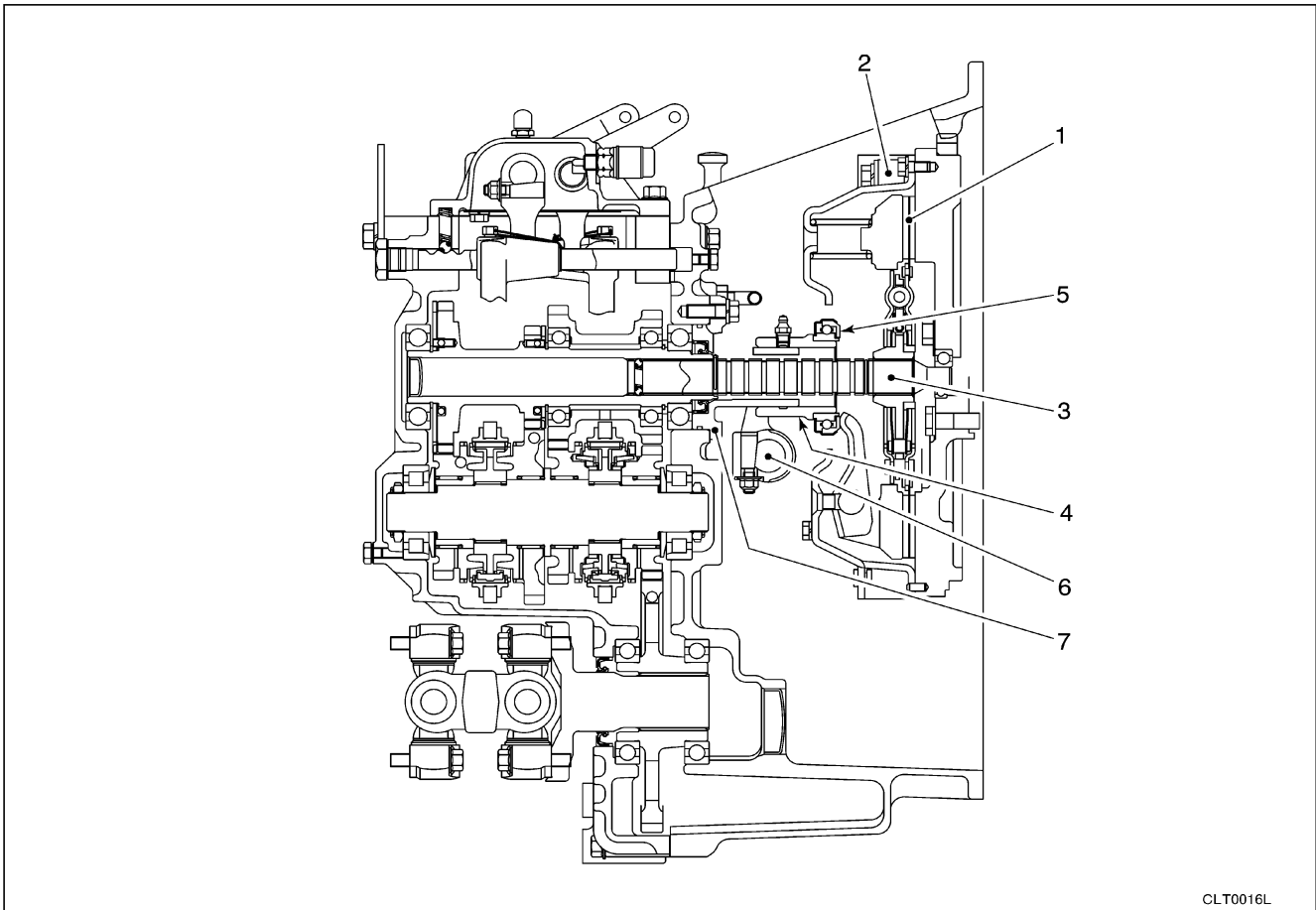

1. Clutch disc
2. Clutch cover assembly
3. Input shaft
4. Release bearing sleeve

5. Release bearing
6. Clutch shifter shaft
7. Front cover

Dry clutch

For the purpose of replacing the clutch disc, a dry clutch has an opening on the upper housing surface. By separating the input shaft and input gear and sliding the spline to the transmission, the clutch disc can easily be replaced.



CAUTION:

- The pressure plate size is common for all vehicle models. Only the number of pressure springs used is different.

Wet clutch

A wet clutch is sealed with a cover because of its mechanism in which the clutch disc is cooled by the return oil of the clutch booster. The cooled oil is returned to the operating oil tank using the turning force of the flywheel.



CAUTION:

- HDS-3-10W oil is used for diesel engine, and this also serves as lubricant. Do not confuse them when filling.
- The pressure plate size is common for all vehicle models. Only the number of pressure springs used is different.

CLUTCH UNIT

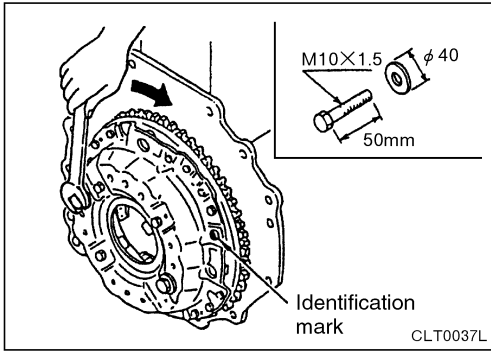

Compression of clutch cover assembly

- Check identification mark

		Engine	K21 2.5L-4C	K25 3.3L-4C
Wet	Items			
	Identification mark		FJ50	FJ51
	Qty./Color		10/Brown	12/Brown

		Engine	K15	K21 2.5L-4C	K25 3.3L-4C
Dry	Items				
	Identification mark		FJ10	FJ20	FK00
	Qty./Color		8/Colorless	12/Colorless	

- Compress the pressure springs using bolts (NFF1145-10050, for removing and installing clutch cover) and washers (NF92301-02700).

Installation of clutch disc assembly

1. Move the input shaft to the position indicated by the dotted line in the figure.

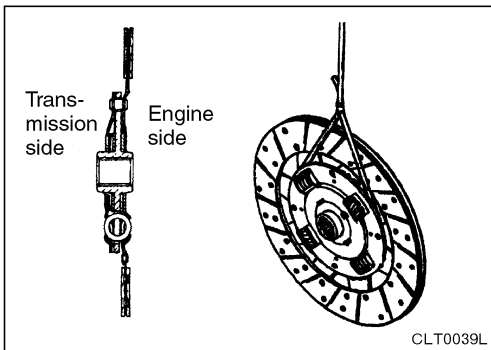
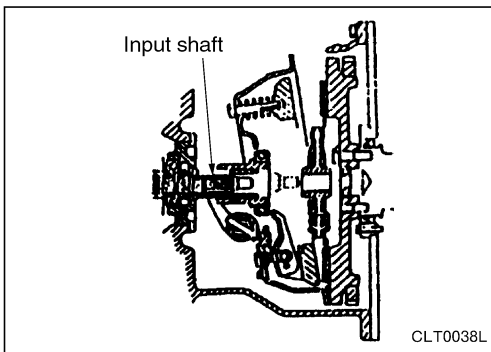

2. Noting the direction in which the disc is installed, hoist and support it with wire and center it with the shaft.

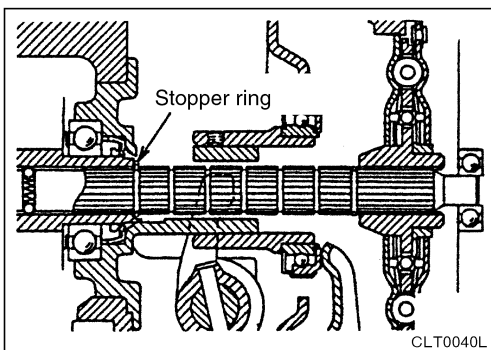

3. As for the input shaft setting position, return it until the input shaft stopper ring is against the input gear. When the locking ball enters the input gear groove, the input shaft is set.

CLUTCH OPERATING CYLINDER

(3) Assembly

Note the following, and assemble in the reverse order of disassembly.

- Wash metal parts with volatile treated oil, and then completely remove the treated oil with compressed air.
- Lightly apply brake fluid or brake-use rubber grease (metal rubber #20) to the interior surfaces of the cylinder body and periphery of the piston cup.
- Watch for the intermixing of foreign material, and be careful not to damage the cylinder body and piston cup lip.
- Air bleeder valve mounting bolt
Tightening torque [N•m (kg-m) Ft./Lbs.]:
7 - 9 (0.7 - 0.9) 9 - 12
- Lock nut mounting bolt
Tightening torque [N•m (kg-m) Ft./Lbs.]:
15 - 17 (1.5 - 1.7) 20 - 23
- Clutch operating cylinder mounting bolt
Tightening torque [N•m (kg-m) Ft./Lbs.]:
11.8 (1.2) 16

REMOVAL AND INSTALLATION

2. REMOVAL AND INSTALLATION

(1) Removal

1. Remove the engine and transmission (as a unit) from the chassis.

NOTE:

- Refer to ER section for removal and installation of the engine and transmission.

2. Remove the drain plug and drain the gear oil from the transmission housing.

3. Remove the drain plug and drain the diesel engine oil from the clutch housing. (Wet type only)

4. Separate the transmission assembly from the engine.

NOTE:

- The clutch disc and clutch cover remain attached to the engine.

(2) Installation

Note the following, and install in the reverse order of removal.

1. With a wet clutch transmission, clean the joint that mates with the engine, and replace the gasket with a new one.

2. Fill the transmission housing with transmission oil. Check it with the oil level gauge.

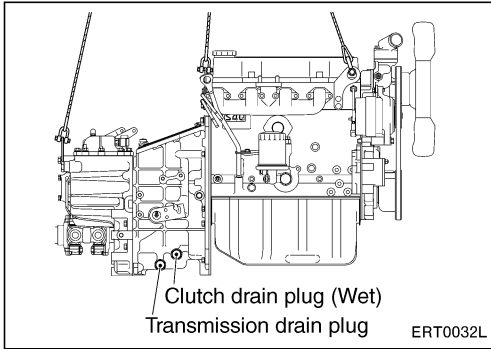

ASSEMBLY

(4) Mainshaft Assembly

Assembly

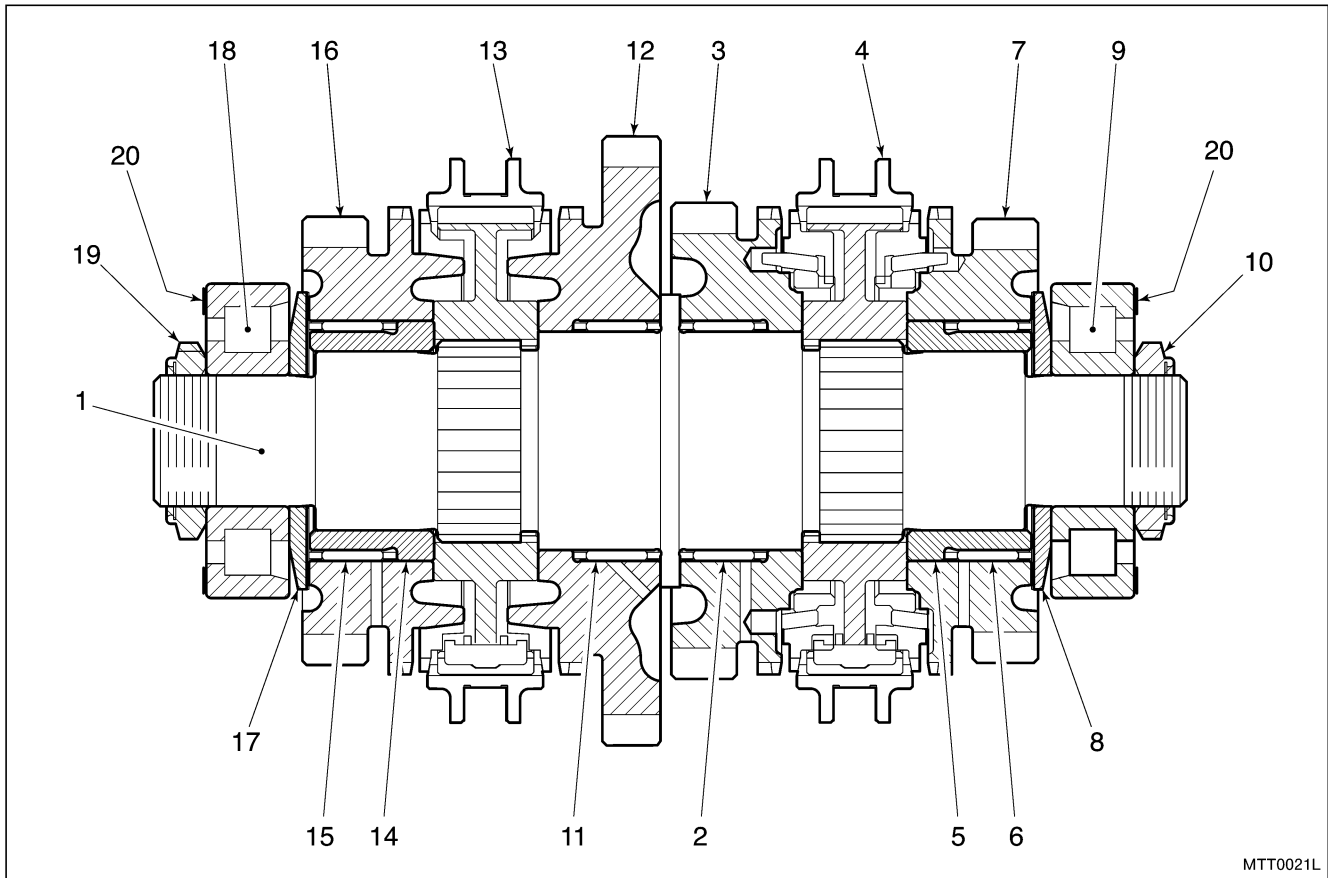

MTT0021L

Order of assembly

- | | |
|-------------------------------|--------------------------------|
| 1. Mainshaft assembly | 11. Needle bearing |
| 2. Needle bearing | 12. Low gear |
| 3. Reverse gear | 13. Synchronesh assembly (H&L) |
| 4. Synchronesh assembly (F&R) | 14. Synchronizer gear sleeve |
| 5. Synchronizer gear sleeve | 15. Needle bearing |
| 6. Needle bearing | 16. High gear |
| 7. Forward gear | 17. Thrust washer |
| 8. Thrust washer | 18. Roller bearing |
| 9. Roller bearing | 19. Nut |
| 10. Nut | 20. Shim |

Assembly

1. Needle bearing
 - Apply gear oil to the needle bearing, and then install.

CONSTRUCTION

(2) Torque Converter

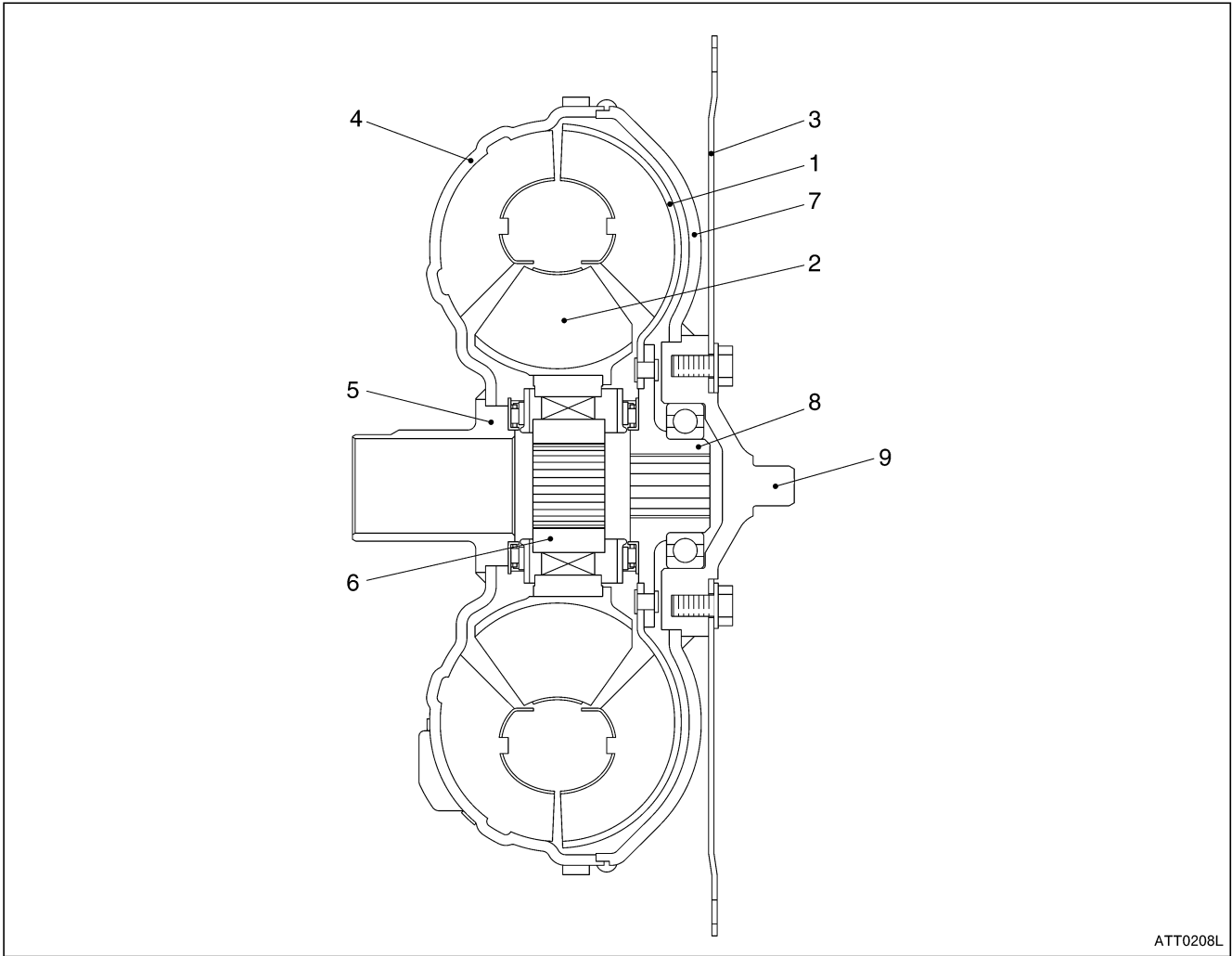

- 1. Turbine runner
- 2. Stator assembly
- 3. Input plate

- 4. Pump impeller
- 5. Pump boss
- 6. Clutch hub

- 7. Drive cover
- 8. Turbine boss
- 9. Pilot boss

CONTROL VALVE

4. CONTROL VALVE

(1) Disassembly (1)

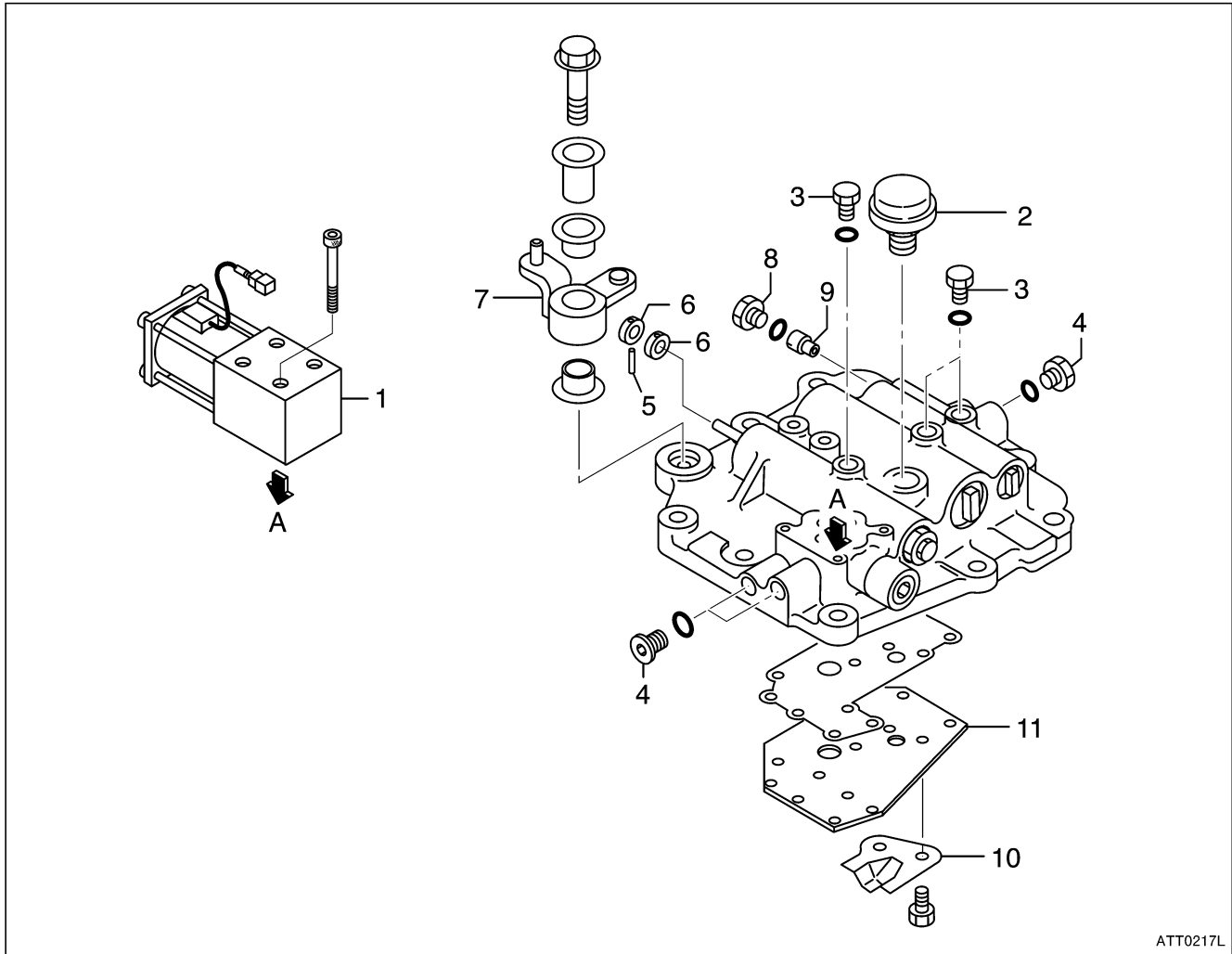

ATT0217L

Order of disassembly

1. Solenoid valve
2. Breather
3. Plug (O-ring)
4. Plug (O-ring)
5. Spring pin
6. Inching rod plate
7. Inching lever (retainer, bushing)
8. Plug (O-ring)
9. Main orifice
10. Breather cover
11. Valve plate (gasket)

INPUT SHAFT ASSEMBLY

(3) Assembly

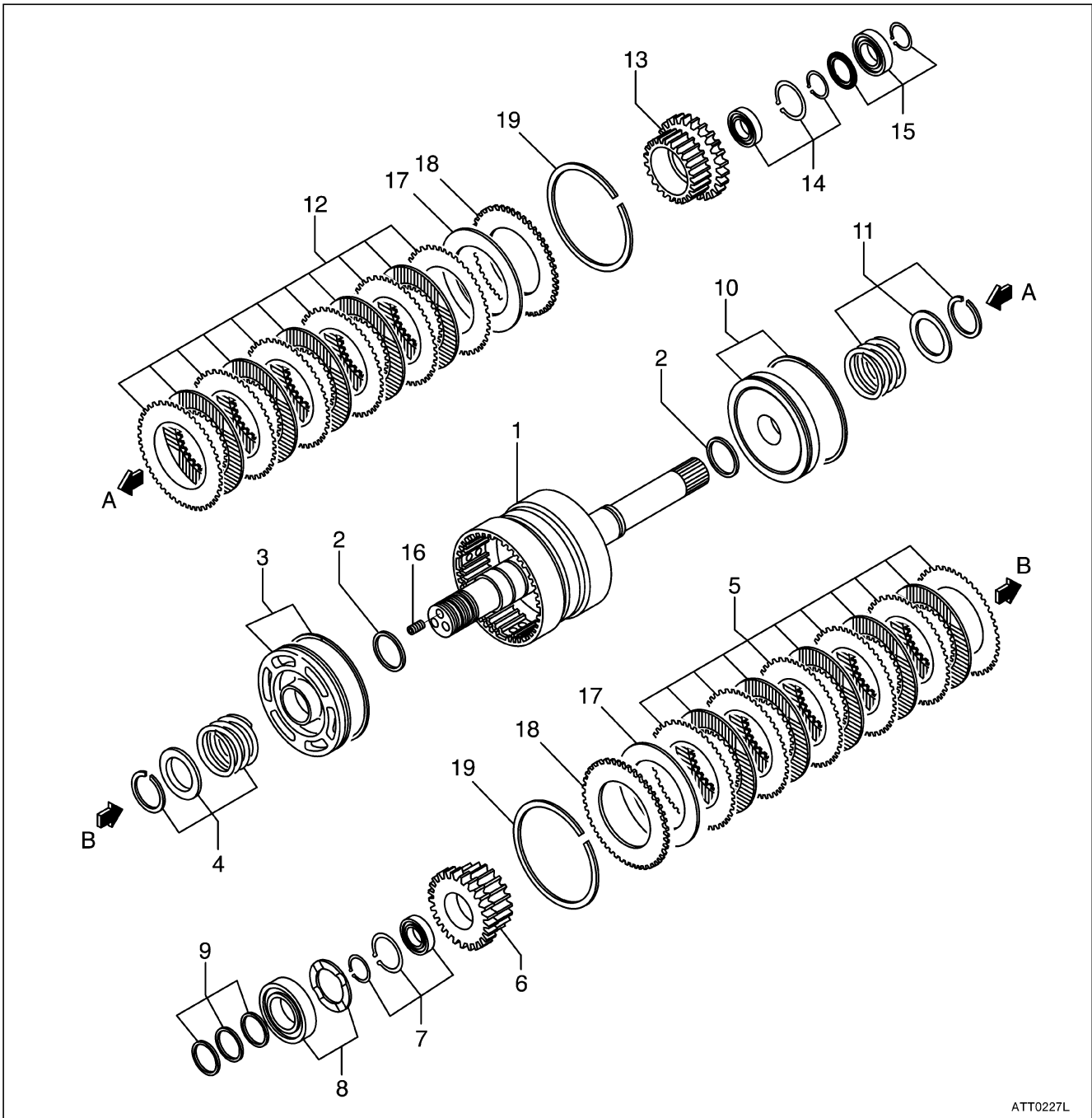

ATT0227L

Order of assembly

- | | |
|---|--|
| 1. Input shaft | 11. Clutch spring (snap ring, spring retainer) |
| 2. Seal ring | 12. Driven plate (6), drive plate (5) |
| 3. Clutch piston (piston ring) | 13. Reverse gear |
| 4. Clutch spring (snap ring, spring retainer) | 14. Angular ball bearing (snap ring [2]) |
| 5. Driven plate (6), drive plate (5) | 15. Bearing (snap ring, ball bearing spacer) |
| 6. Forward gear | 16. Setscrew |
| 7. Angular ball bearing (snap ring [2]) | 17. Clutch facing (conical plate) |
| 8. Bearing (input shaft spacer) | 18. Retaining plate |
| 9. Seal ring (3) | 19. Snap ring |
| 10. Clutch piston (piston ring) | |

MEMO

TROUBLESHOOTING

DAMAGE DIAGNOSIS

Power Output Down (continued)	Transmission (continued)	Inadequate Oil Used or Bubbling	Inadequate or bubbling.	Inspect.	Replace oil.	
			Air sucked in from suction side.	Inspect piping.	Tighten or replace bolt.	
			Low torque converter pressure has caused bubble to occur inside.	Check pressure; inspect control valve.	Clean, repair, or replace.	
			Water mixed in oil.	Remove oil and inspect.	Replace oil.	
			Inching cable not adjusted properly.	Inspect.	Adjust.	
		Clutch Slips	Main pressure too low.	Check oil pressure. Inspect oil pump and control valve.	Replace.	
			Piston D-ring or O-ring worn.	Disassemble, inspect and measure.		
			Clutch piston damaged.	Disassemble and inspect.		
			Seizing or slip of clutch disc.	Check if vehicle can be moved with gear in neutral position.		
			Clutch wear.	Disassemble, inspect and measure.		
			Malfuction due to electric current interruption caused by damaged electromagnetic valve, or foreign matter.	Inspect.	Replace electromagnetic valve assembly.	
	Hydraulic System Not In Order	Pressure Too High		Malfuction of regulator valve.	(1) Verify the spool functions properly. (2) Verify valve body orifice is open.	(1) Replace the valve. (2) Clean or repair.
				Malfuction of torque converter relief valve.	Verify the spool functions properly.	Replace
				Cold environment -- oil viscosity too high.	When outdoor temperature is below 0°, warm oil to 60 - 80°C (140 - 176°F) and check again.	
				Oil being used not adequate.	Inspect.	
Pressure Too Low			Gear pump damaged (worn out)	Disassemble and inspect	Replace	
			Excessive oil leakage: (1) Defective regulator valve coil spring. (2) Defective regulator valve spool.	(1) Check load of spring. Refer to spring standards. (2) Disassemble and inspect.	(1) Replace. (2) Correct or replace the valve.	
			Air being sucked in.	Inspect oil filter and piping on suction side.	Clamp the packing tighter, or replace it.	
			Oil volume insufficient.	Inspect oil surface.	Replenish oil.	
			Oil filter clogging.	Inspect.	Clean and replace.	
Transmission			Excessive leakage.	Disassemble and inspect seal ring, O-ring and others. Measure hydraulic pressure.	Replace.	
			Malfuction due to defective electromagnetic valve, or current interruption due to foreign matter.	Inspect.	Replace electromagnetic valve assembly.	

(7) REMOVING THE REDUCTION GEARS.

1. Flatten the lock washer.
2. Remove the lock nut. Tightening torque:
245 - 294 N-m; 25 - 30 kgf/m; 181 - 218 ft/bs.
3. Remove the lock washer.
4. Lift the reduction gear by using tire levers.
5. Remove the bearing.
6. Remove the spacer.
7. Remove the reduction gears.

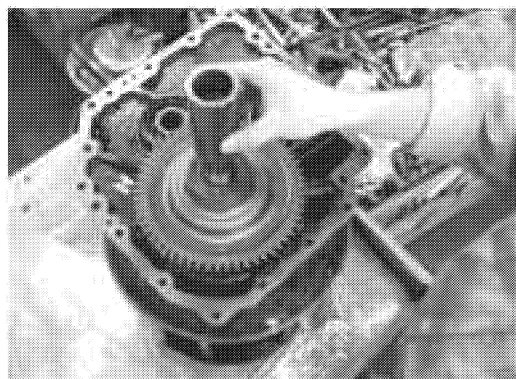
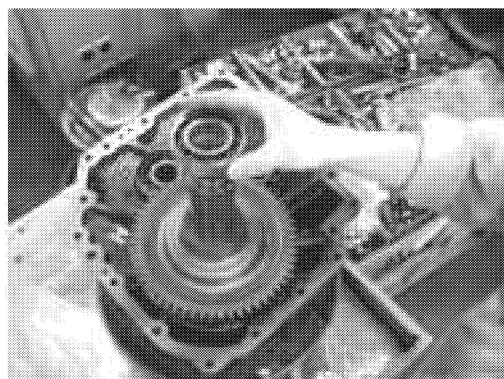
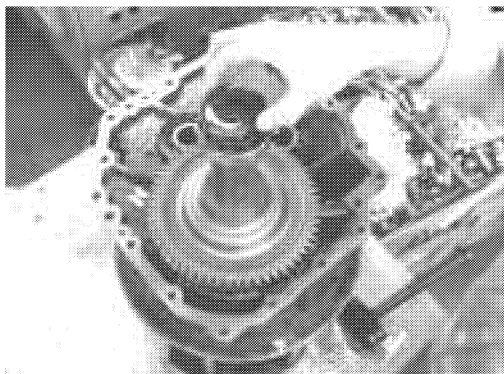
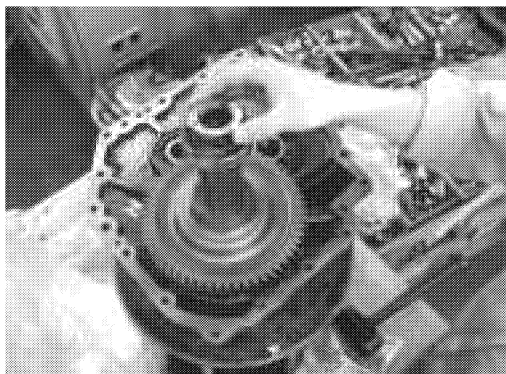

MAINTENANCE



Gear Pump

The two flat surfaces provided at the front end of the torque converter impeller hub drive the drive gear directly.

The compact internal gear pump employed provides a quite silent operation.

Hydraulic Clutch

The clutch contains drive plates, 4 pieces each front and rear, 5 clutch disks, one each of conical drive plate, piston, back plate.

By the function of the piston, the conical drive plate is pressed on the clutch disk, causing the power transmitted to the gears through the clutch cover that has been put together with the clutch shaft, and disk.

At the neutral position the clutch piston is caused reverse operational due to the coil springs to release the clutch.

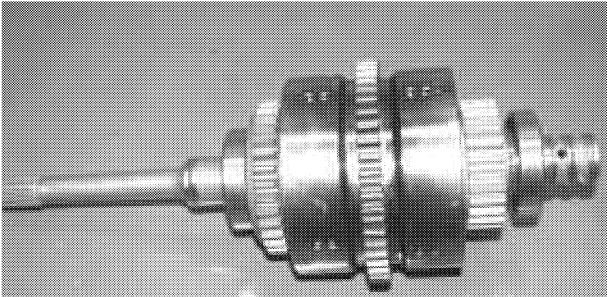

DISASSEMBLY / REASSEMBLY

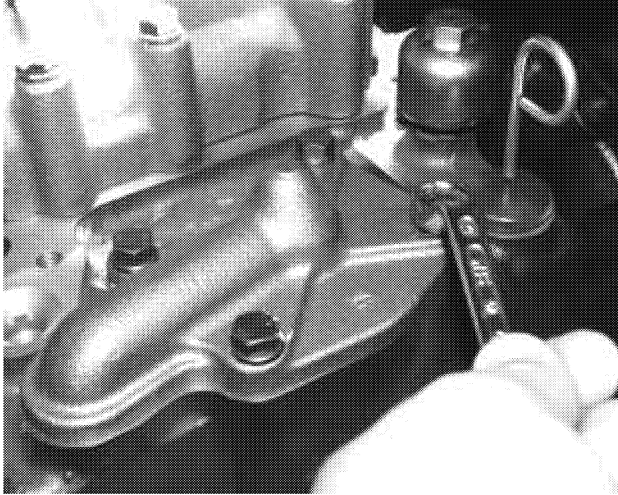

5. Remove the strainer cover mounting bolts (M8 x 4 pcs) on the top of the housing and the pipe fixing bolts (M10 x 1 pc) in the housing to remove the strainer, O-ring and pipe (spanner 13 mm, 17 mm).
6. Remove the mounting bolts (M10 x 1 pc) in the housing of the hydraulic clutch assembly (2 sets) and idler gear, to remove the idler gear and shaft bearing (spanner 17 mm).
7. Remove the cover fixing bolts (M10 x 2 pcs) on the side of the housing to pull out the cover, gasket, spring, piston (2 pcs) (spanner 14 mm).
8. Raise the coaked portion of the lock washers to remove the lock nuts to remove the bearing, collar and gear (flat head screw driver, hammer and spanners 50 mm and 17 mm).
9. Remove the plug (M24) connected with the cooler outlet to pull out the ball and spring (spanner 32 mm).

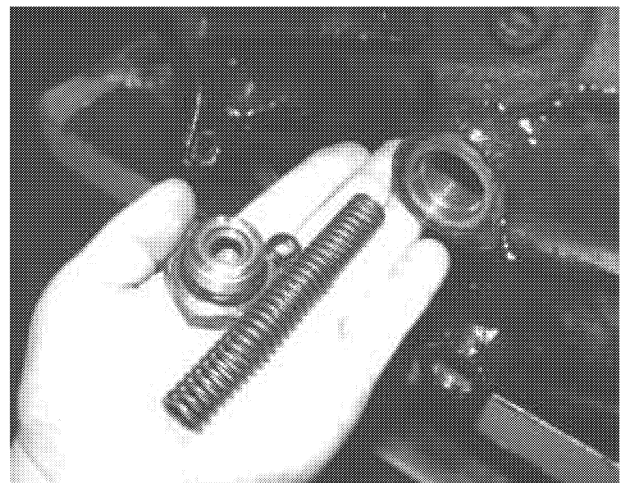
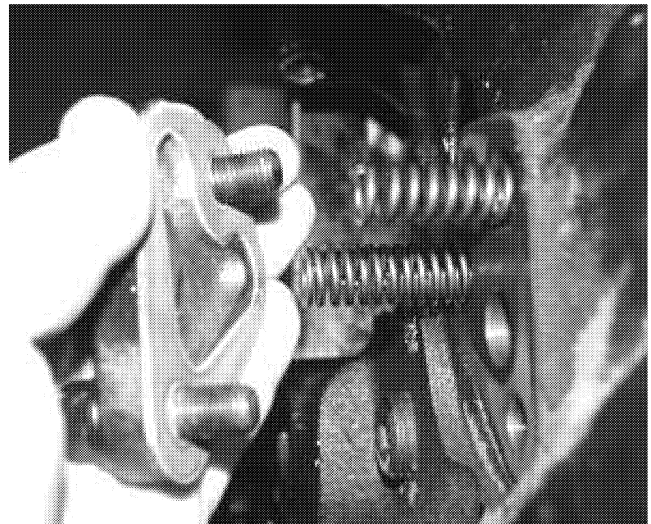
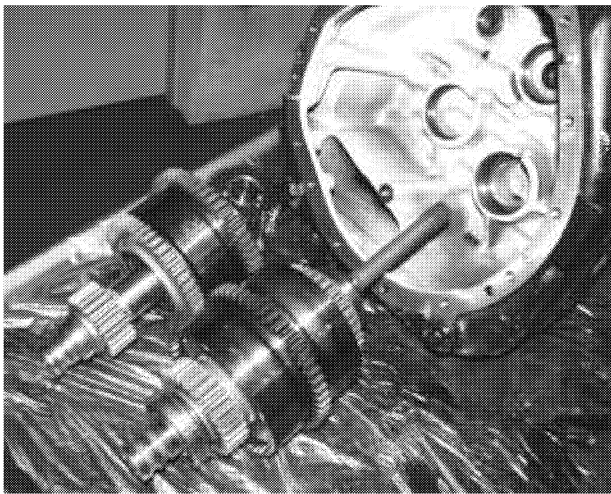

TORQUE

6. Bolt Plug Tightening Torque

Torque Values

Part		Tightening Part	Screw Specification		Torque: N-m (kg-m) Ft./Lbs.	
					Min.	Max.
Torque Converter	1	Input plate mounting*	Hexagonal bolt	M10 x 1.5 x 16	58 (5.9) 42.7	75 (7.7) 55.3
Transmission	2	Clamping of breather	Breather	PT1/4	13 (1.3) 9.6	17 (1.7) 12.5
	3	Clamping of draining plug	Magnet plug	M24 x 1.5	59 (6.0) 43.5	78 (8.0) 57.5
	4	Control valve mounting	Hexagonal bolt	M8 x 1.25 x 95	31 (3.2) 22.9	37 (3.8) 27.3
	5	Control valve mounting	Hexagonal bolt	M8 x 1.25 x 65	31 (3.2) 22.9	37 (3.8) 27.3
	6	Differential carrier and housing mounting	Hexagonal bolt	M10 x 1.5 x 30	58 (5.9) 42.8	74 (7.6) 54.6
	7	Strainer cover mounting	Hexagonal bolt	M8 x 1.25 x 25	31 (3.2) 22.9	37 (3.8) 27.3
	8	Main pressure adjusting and inlet pressure valve cover mounting	Hexagonal bolt	M10 x 1.25 x 30	41 (4.2) 30.2	53 (5.4) 39.1
	9	Gear pump mounting	Hexagonal bolt	M8 x 1.5 x 40	31 (3.2) 22.9	37 (3.8) 27.3
	10	Counter gear fixing bolt mounting*	Hexagonal bolt	M10 x 1.5 x 45	58 (5.9) 42.8	74 (7.6) 54.6
	11	Cooler relief valve clamping	Plug	M24x1.5	69 (7.0) 50.1	78 (8.0) 57.5
	12	Safety cover mounting	Hexagonal bolt	M8 x 1.25 x 20	31 (3.2) 22.9	37 (3.8) 27.3
	13	Mounting of mission internal piping*	Hexagonal bolt	M10 x 1.5 x 20	58 (5.9) 42.8	74 (7.6) 54.6
	14	Revolution speed meter outlet blind plug fixing	Hexagonal bolt	M22 x 1.5	49 (5.0) 36.1	64 (6.5) 47.2
	15	Oil temperature switch clamping	Oil temperature switch	M16 x 1.5	31.4(3.2) 23.2	47.1 (4.8) 34.7
	16	Choke	Hexagonal socket screw	M8 x 1.25	4.4 (0.45) 3.25	5.9 (0.6) 4.35
	17	Clamping of output shaft lock nut	Hexagonal socket nut	M35 x 1.5	196 (20.0) 144.5	225 (23.0) 166
	18	Hydraulic hole blind plug	Plug	PT1/8	8 (0.8) 5.9	12 (1.2) 8.9
	19	Hydraulic hole blind plug	Plug	PT1/4	13 (1.3) 9.6	17 (1.7) 12.5
	20	Hydraulic hole blind plug	Plug	PT1/2	37 (3.8) 27.3	51 (5.2) 37.6

DIFFERENTIAL CARRIER

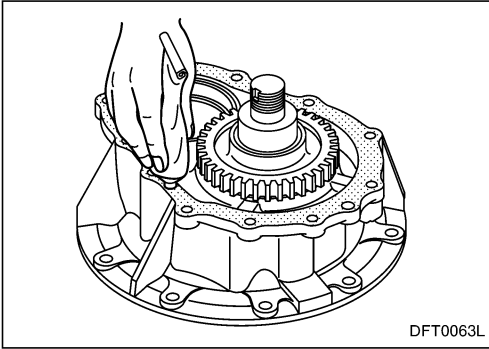

Applying liquid packing

When assembling the differential carrier and carrier cover, apply liquid packing to the joint surface.

Liquid packing: Three Bond No. 1104

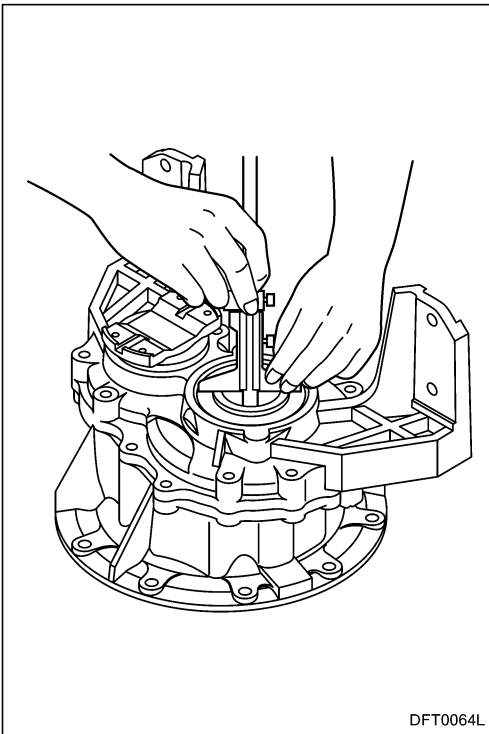

Adjustment of drive pinion preload

1. After tapping in the tapered roller bearing, measure the difference between the drive pinion and tapered roller bearing. Although the measured dimension will serve as a target value for the shim thickness, the standard for the shim thickness is 1.25 mm, 0.049 in.
2. Insert a shim having the measured dimension, and then tighten the plate.
There are 5 shim thicknesses: 0.05, 0.1, 0.2, 0.5, and 1.0 mm; 0.002, 0.0039, 0.0079, 0.0197 and 0.039 in.

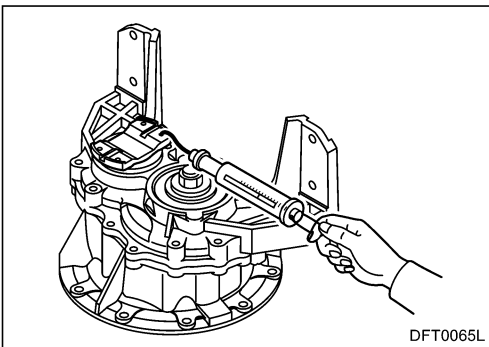

3. Install the spring balance to the screw hole of the input flange, and pull in the tangential direction. Check the preload of the tapered roller bearing, using the weight that was applied when movement started. Adjust the size of the shim until the specified tensile force is obtained.

Input flange preload [N (kg) Lbs.]:

34.32 - 49.03 (3.4 - 4.9) 7.5 - 10.8

REMOVAL AND INSTALLATION

(6) C1F1 models

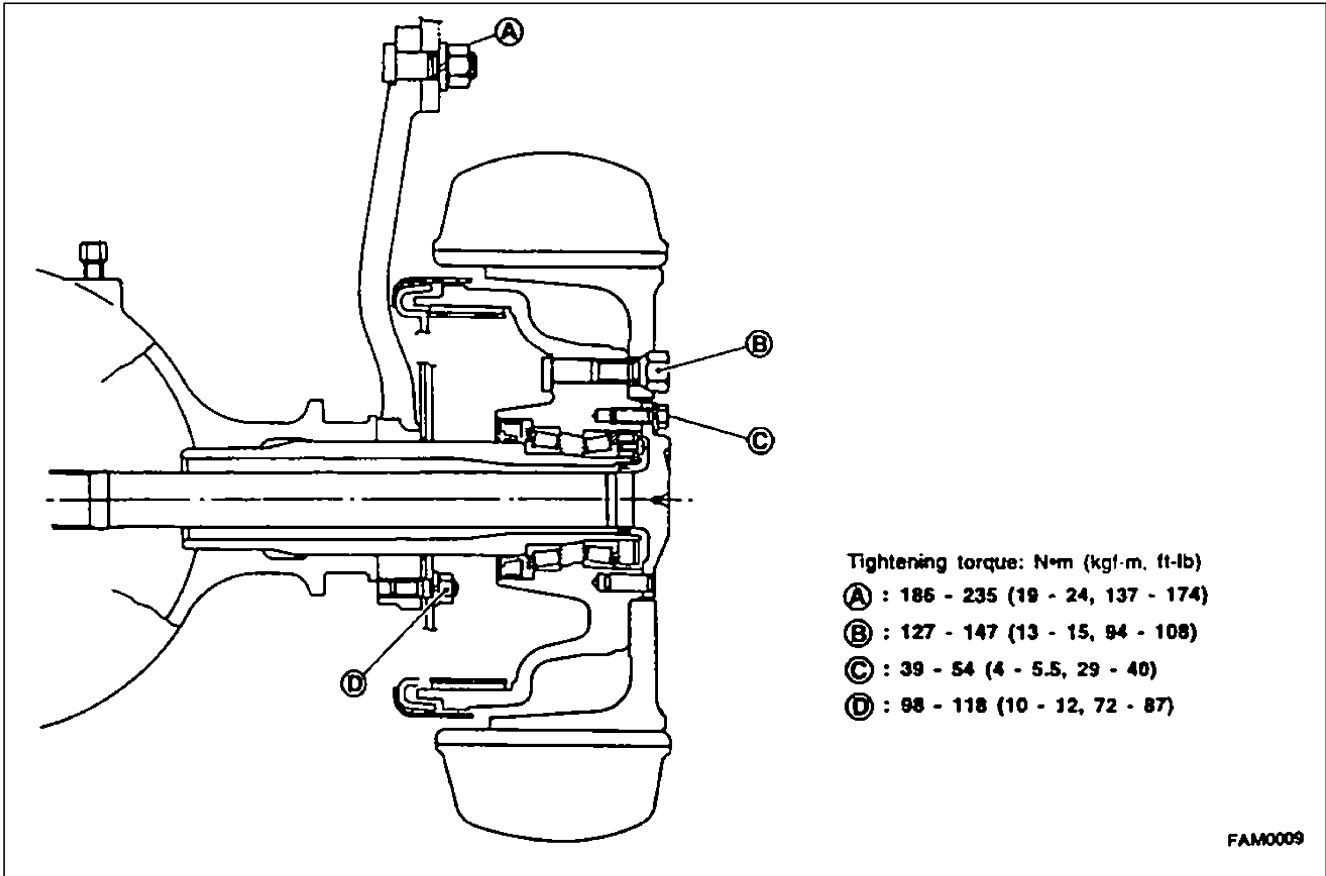

STEERING AXLE

SECTION SA

CONTENTS

- 1. DESCRIPTION SA- 2
- 2. SPECIFICATION SA- 2
- 3. TROUBLE DIAGNOSES AND CORRECTIONS SA- 2
- 4. CONSTRUCTION SA- 3
- 5. REMOVAL AND INSTALLATION SA- 4
 - (1) Steering Tire SA- 4
 - (2) Steering Axle SA- 5
- 6. DISASSEMBLY AND ASSEMBLY SA- 8
- 7. STEERING AXLE HUB SA- 9
 - (1) Removal SA- 9
 - (2) Inspection SA- 9
 - (3) Installation SA- 9
 - (4) Wheel Bearing Adjustment SA-10
- 8. KINGPIN SA-11
 - (1) Removal SA-11
 - (2) Inspection SA-11
 - (3) Installation SA-12
 - (4) Construction of Kingpin Angle Sensor SA-13
- 9. STEERING AXLE COMPONENT PARTS LOCATION SA-14
- 10. SPINDLE DETAILS SA-15
- 11. SERVICE DATA AND SPECIFICATIONS (SDS) SA-16
 - (1) Steering Axle Upper Surface SA-16
 - (2) Steering Axle Front Surface SA-17



NOTE: This section contains information and specifications for both carbureted general overseas market models, as well as, electronic control models (manufactured in USA.) Therefore, ensure the specifications or procedures you are looking at are for the proper fuel delivery system; electronic controlled or carbureted.

KINGPIN

8. KINGPIN

(1) Removal

1. Disassemble spindle and tie-rod bar.
2. Loosen lock nut, and then remove lock screw.
3. Remove grease nipple, dust cover, and wheel angle sensor from kingpin upper, and then drive out kingpin downward while positioning a piece of metal on the kingpin.

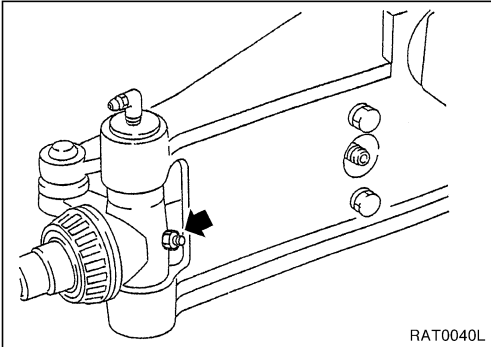

CAUTION:

- Hold kingpin so as not to drop.
- Install the plate for wheel angle sensor positioning to kingpin RH. Do not deform the plate when installing.

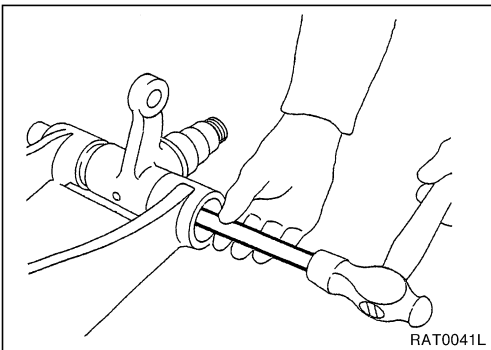

4. Remove spindle together with thrust bearing and shim.
5. Pull out grease seal and needle bearing if necessary.

(2) Inspection

Clean each disassembled part and check.

Needle bearing, thrust bearing

- Check for damage, seizure, peeling, improper rotation, noise, corrosion, and deformation. Replace if necessary.
- Check seal and O-ring of needle bearing and thrust bearing for damage and excessive wear. Replace if necessary.

Spindle

- Check for cracks (by dye test). Replace if necessary.

Grease seal

- Check for cracks (by dye test). Replace if necessary. Also replace if grease seal is removed from steering axle.

SPECIFICATION

Lifting Capacity	Load Center	Model	Wheel Disc & Tire Size
1F1 Series - Cushion Tire Models			
3,000 lbs. (1.5 ton)	24 in. (500 mm)	CP1F1A15JV, JS, JU CP1F1A15DV, DS, DU CP1F1A15LV, LS, LU	Drive: Wheel Disc :12-1/8" Tire: 18 x 6 x 12-1/8
3,500 lbs. (1.75 ton)		CP1F1A18JV, JS, JU CP1F1A18DV, DS, DU CP1F1A18LV, LS, LU	Steer: Wheel Disc: 10" Tire: 14 .x 5 x 10 (High Load) 78 Durometer
4,000 lbs. (2.0 ton)		CP1F1A20JV, JS, JU CP1F1A20DV, DS, DU CP1F1A20LV, LS, LU	
1F1 Series - Compact Pneumatic Models			
3,000 lbs. (1.5 ton)	24 in. (500 mm)	AP1F1A15JV, JS, JU AP1F1A15DV, DS AP1F1A15LV, JLS, LU	Drive: Wheel Disc: 4.00 E-9 Tire: 6.00 - 9/12
3,500 lbs. (1.75 ton)		AP1F1A18JV, JS, JU AP1F1A18DV, DS AP1F1A18LV, LS, LU	Steer: Wheel Disc: 3.00 DX8 Tire: 5.00 - 8 - 8
1F2 Series - Cushion Tire Models			
4,000 lbs. (2.0 ton)	24 in. (500 mm)	CX*1F2A20JV, JS,JU CX*1F2A20DV,DS CX*1F2A20LV,LS,LU	Drive: Wheel Disc: 15 Tire: 21 x 7 x 15
5,000 lbs. (2.5 ton)		CX*1F2A25JV, JS,JU CX*1F2A25DV,DS CX*1F2A25LV,LS,LU	Steer: Wheel Disc: 11-1/4 Tire: 16-1/4 x 6 x 11-1/4
5,500 lbs. (2.75 ton)	24 in. (500 mm)	CX*1F2A28JV, JS,JU CX*1F2A28DV,DS CX*1F2A28LV,LS,LU	Drive: Wheel Disc: 15 Tire: 21 x 8 x 15
6,000 lbs. (3.00 ton)		CP1F2A30JV, JS,JU CP1F2A30DV,DS CP1F2A30LV,LS,LU	Steer: Wheel Disc: 11-1/4 Tire: 16-1/4 x 6 x 11-1/4 (High Load) 78 Durometer
6,500 lbs. (3.25 ton)		CU1F2A33JV, JS,JU CU1F2A33DV,DS CU1F2A33LV,LS,LU	
6,000 lbs. (3.00 ton)	24 in. (500 mm)	CUG1F2A30JV, JS,JU CUG1F2A30DV,DS CUG1F2A30LV,LS,LU	Drive: Wheel Disc: 16; Tire: 22 x 8 x 16 Steer: Wheel Disc: 12-1/8; Tire: 18 x 6 x 12-1/8 (HL) 78 Durometer
7,000 lbs. (3.5 ton)	24 in. (500 mm)	CUG1F2A35JV, JS,JU CUG1F2A35DV,DS CUG1F2A35LV,LS,LU	Drive: Wheel Disc: 16 Tire:22 x 8 x 16
8,000 lbs. (4.0 ton)		CUG1F2A36JV, JS,JU CUG1F2A36DV,DS CUG1F2A36LV,LS,LU	Steer: Wheel Disc: 12-1/8 Tire: 18 x 6 x 12-1/8 (High Load) 78 Durometer
L02 Series - Compact Pneumatic Models			
5,000 lbs (2.5 ton)	24 in. (500 mm)	AP1F2A25JV, JS,JU AP1F2A25DV,DS AP1F2A25LV,LS,LU	Drive Wheel Disc: 6.00E x 9TB; Tire: 21 x 8 - 9/14 PR Steer: Wheel Disc:: 4.33R x 8DT Tire: 18 x 7 - 8/14PR

* Replace "X" with "P" for models with K21 engine or "U" for models with K25 engine

2. DISASSEMBLY AND ASSEMBLY

(1) Master Cylinder

Disassembly

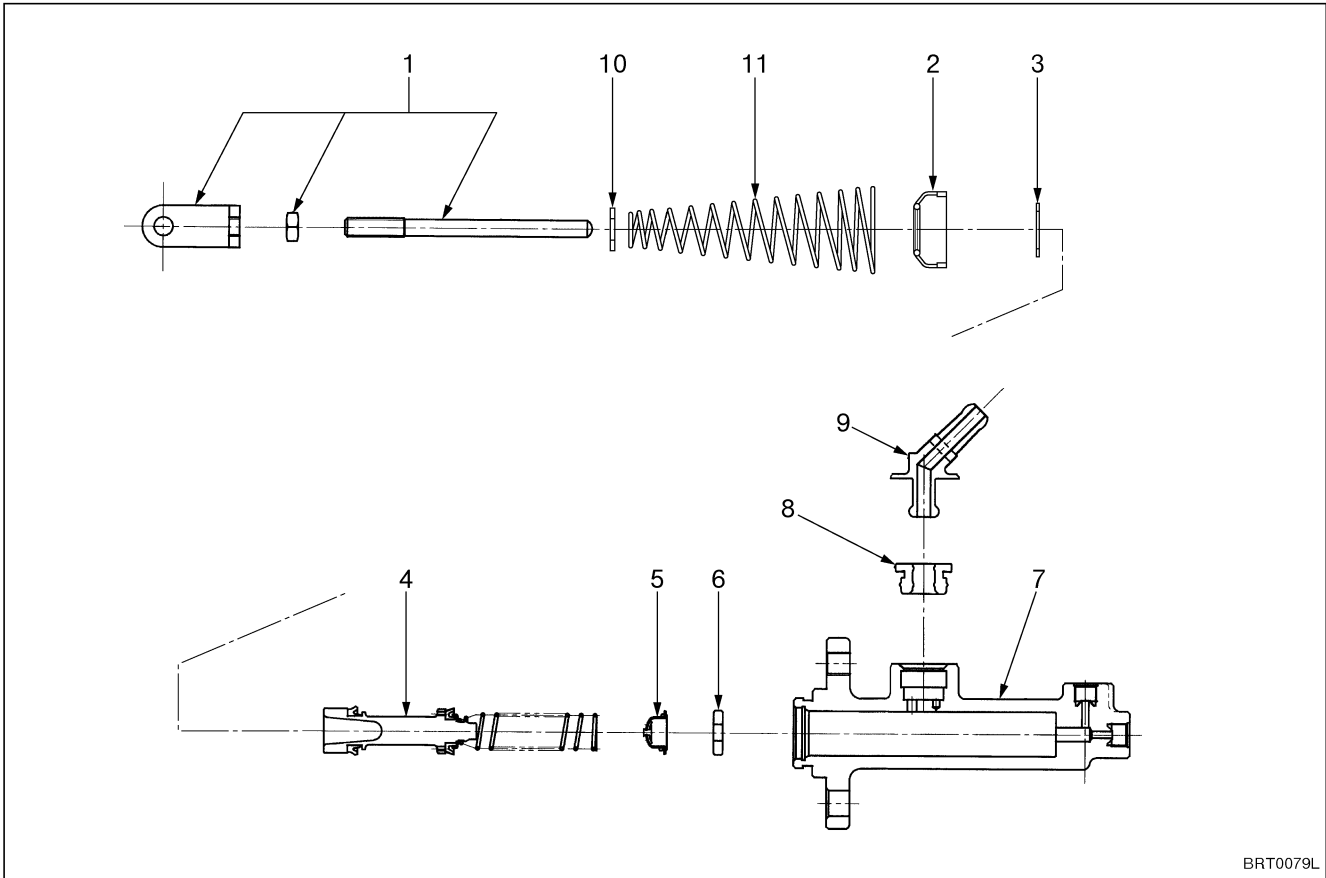

BRT0079L

Order of disassembly

- | | |
|--------------------------|-------------------------|
| 1. Clevis, nut, push rod | 7. Cylinder body |
| 2. Boot | 8. Filler union bushing |
| 3. Snap ring | 9. Filler union |
| 4. Piston assembly | 10. Flat washer |
| 5. Valve assembly | 11. Spring |
| 6. Valve seat | |

3. INSPECTION AND ADJUSTMENT

(1) Performance Test for Automatic Adjuster

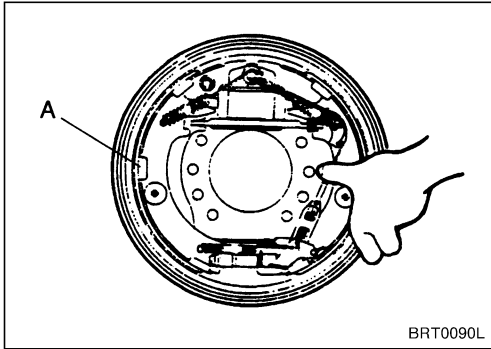

1. If the fitting cable is pulled toward you with fingers when the clearance (A) between the lining and drum is approximately normal, the lever will return to its original position after one tooth of the screw passes.

- Clearance (A) between lining and drum
Standard (mm, in.):
1F1 (0.25 - 0.5, 0.010 - 0.020)
1F2 (0.1 - 0.35, 0.004 - 0.014)

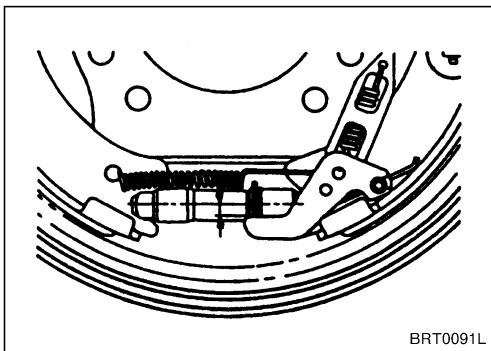

2. If the lever action is slow, check the position of the lever under the adjusting screw.

- The lever is designed to make contact with the adjusting screw about 7 to 9 mm below the screw centerline. If this position is improper, the lever will not engage correctly with the screw's teeth, and the screw will not rotate correctly even if the lever operates.

3. If the automatic adjuster does not operate correctly, take the following actions:

- Make sure that the adjusting spring is correctly attached to the prescribed hole of the primary shoe.
- Replace adjusting cable.
- Replace adjusting lever.
- Replace adjuster.

(2) Manual Adjustment Procedure

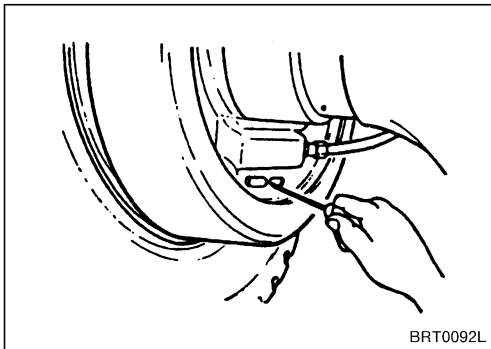

Insert a screwdriver into the adjusting hole on the back of the backing plate. Then turn the adjusting screw to adjust the clearance between the drum and lining.

NOTE:

- Turning the screw by one tooth makes an adjustment of 0.03 mm (diameter).

STEERING SYSTEM

SECTION **ST**

CONTENTS

1. DESCRIPTION	ST- 2	7. PS CYLINDER	ST-19
(1) Knob Position Control System	ST- 3	(1) Construction	ST-19
2. SPECIFICATION	ST- 4	(2) Specification	ST-19
3. TROUBLE DIAGNOSIS AND CORRECTIONS	ST- 5	(3) Removal	ST-20
4. STEERING WHEEL	ST- 6	(4) Installation	ST-20
(1) Removal	ST- 6	(5) Troubleshooting	ST-21
(2) Inspection	ST- 6	(6) Disassembly	ST-23
(3) Installation	ST- 6	(7) Assembly	ST-25
(4) Inspection After Installation	ST- 7	(8) Inspection After Assembly	ST-28
5. STEERING COLUMN	ST- 8	(9) Periodical Inspection and Maintenance	ST-29
(1) Construction	ST- 8	8. PIPING	ST-31
(2) Removal	ST- 8	(1) Construction	ST-31
6. PS VALVE	ST-10	(2) Removal	ST-31
(1) Parts Construction	ST-10	(3) Inspection	ST-31
(2) Disassembly	ST-12	(4) Installation	ST-31
(3) Inspection	ST-13		
(4) Assembly	ST-14		
(5) Trouble Diagnosis and Corrections	ST-17		

NOTE: This section contains information and specifications for both carbureted general overseas market models, as well as, electronic control models (manufactured in USA.) Therefore, ensure the specifications or procedures you are looking at are for the proper fuel delivery system; electronic controlled or carbureted.



PS VALVE

Parts list

No.	Description	Quantity	Remarks
1	Screw	6	
2	Retainer screw assembly	1	
3	End cap	1	
4	Gerotor	1	
5	Spacer	1	
6	-	-	Missing number
7	Spacer plate	1	
8	Drive	1	
9	Control parts assembly	1	Including items Nos. 10 to 12
10	Housing	(1)	
11	Sleeve	(1)	
12	Spool	(1)	
13	Pin	1	
14	Centering spring	4	Ultra-low input version
15	-	-	Missing number
16	Race bearing	2	
17	Thrust needle bearing	1	
18	O-ring	1	
19	Oil seal	1	
20	Dust seal	1	
21	Retaining ring	1	
22	Seal gland bushing	1	
23	O-ring	2	
24	O-ring	1	
25	Adapter screw	1	
26	Ball	1	
27	Plug	1	
28	O-ring	1	
29	Nameplate	1	
30	Rivet	2	

PS CYLINDER

(5) Troubleshooting

Condition	Possible causes		Corrective action
Oil leakage from piston rod sliding face *: Refer to "(8) Inspection After Assembly" for judgement.	Piston rod	<ul style="list-style-type: none"> Rust or scratches on sliding face, which can be felt by fingernails. 	1. Eliminate the scratches and smoothen the sliding face (1.5 s or less) using oilstone. If the oil still leaks, the sealing parts such as U-ring may be damaged by the scratches. Overhaul the piston. 2. If the scratches and rust zone is too wide to repair with oilstone, replace the piston rod, U-ring, seals such as the wiper ring, and piston rod bearings.
		<ul style="list-style-type: none"> Detached plating 	1. Re-plate or replace the piston rod. 2. At the same time, inspect the seals and piston rod bearings, and replace them if necessary.
	Rod packing (U-ring)	<ul style="list-style-type: none"> Foreign object in inner/outer faces 	1. Remove the foreign objects. 2. Replace any damaged packing.
		<ul style="list-style-type: none"> Scratches on inner/outer faces 	1. Replace.
		<ul style="list-style-type: none"> Lip and groove partially carbonized (burnt) 	1. The symptom may be caused by adiabatic compression of residual air in the cylinder. 2. After replacing the packing, always perform initial operations at low pressure and low speed to bleed the air from the cylinder sufficiently.
		<ul style="list-style-type: none"> Packing deteriorated in elasticity and shredded in pieces Lip faces widely lost 	1. Replace. 2. The packing may have reached its end of life or the fluid may have been deteriorated or overheated. <ul style="list-style-type: none"> Replace the fluid. Check the fluid temperature. (The desirable temperature is 80°C or less.) Check for any partially heated portion.
		<ul style="list-style-type: none"> Excessive projection of packing heel 	1. Replace. 2. The packing may be subject to excessive high pressure. <ul style="list-style-type: none"> Check the operation pressure. If equipped with a buffer ring, the buffer ring may be the cause. Check the buffer ring.
	Backup ring	<ul style="list-style-type: none"> Largely deformed 	1. As a rule, also replace the rod packing. (If equipped with a buffer ring, the buffer ring should be replaced at the same time.) 2. The cause may be excessive high pressure. In this case, follow the above instructions for the excessive projection of packing heel.
	Wiper ring	<ul style="list-style-type: none"> Foreign objects in lip 	1. Remove the foreign objects.
		<ul style="list-style-type: none"> Damaged lip Other damages 	1. Replace.
Bearing materials	<ul style="list-style-type: none"> Too much wear resulting in excessive gap with piston rod (Refer to "(6) Disassembly", "Maintenance criteria".) 	1. Replace.	
	<ul style="list-style-type: none"> Large scratches on sliding face 	1. Replace. 2. At the same time, inspect the piston rod.	
Oil leakage from piston rod sliding face *: Refer to "(8) Inspection After Assembly" for judgement.	Cylinder head	<ul style="list-style-type: none"> Cylinder head used in piston rod contains rust or scratches on seal fitting face. Refer to "Bearing materials" above. 	1. Remove the scratches and rust with oilstone. 2. If not repairable, replace the cylinder head.

8. PIPING

(1) Construction

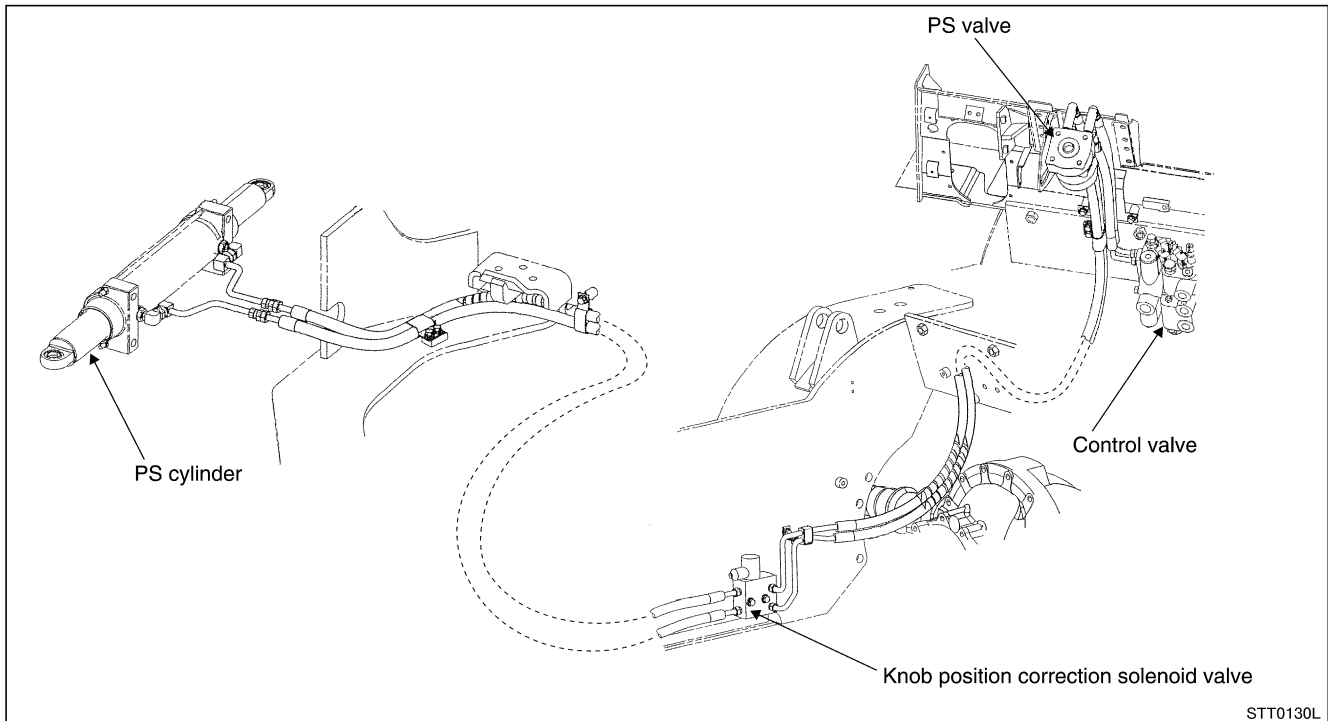

- The above figure illustrates the hydraulic line from the PS valve to the PS cylinder.

(2) Removal

- Disconnect the connections.



CAUTION:

- Use a shop cloth to cover the tube and hose ends to catch spilling fluid.

(3) Inspection

- Any deformed, damaged or cracked tubes and hoses must be replaced.

(4) Installation

Be careful of the following when installing.

- Ensure that the tubes and hoses are free from foreign objects, deformation, crushing and scratches.
- To connect a flare nut joint, set the tube perpendicularly to the seating face and tighten the flare nut loosely, then tighten it to the specified torque.

Tightening torque [N•m (kg-m) Ft./Lbs]:

39 - 43 (4.0 - 4.4) 29 - 32

HYDRAULIC PIPING

3. HYDRAULIC PIPING

(1) 1F1 Vehicle Type

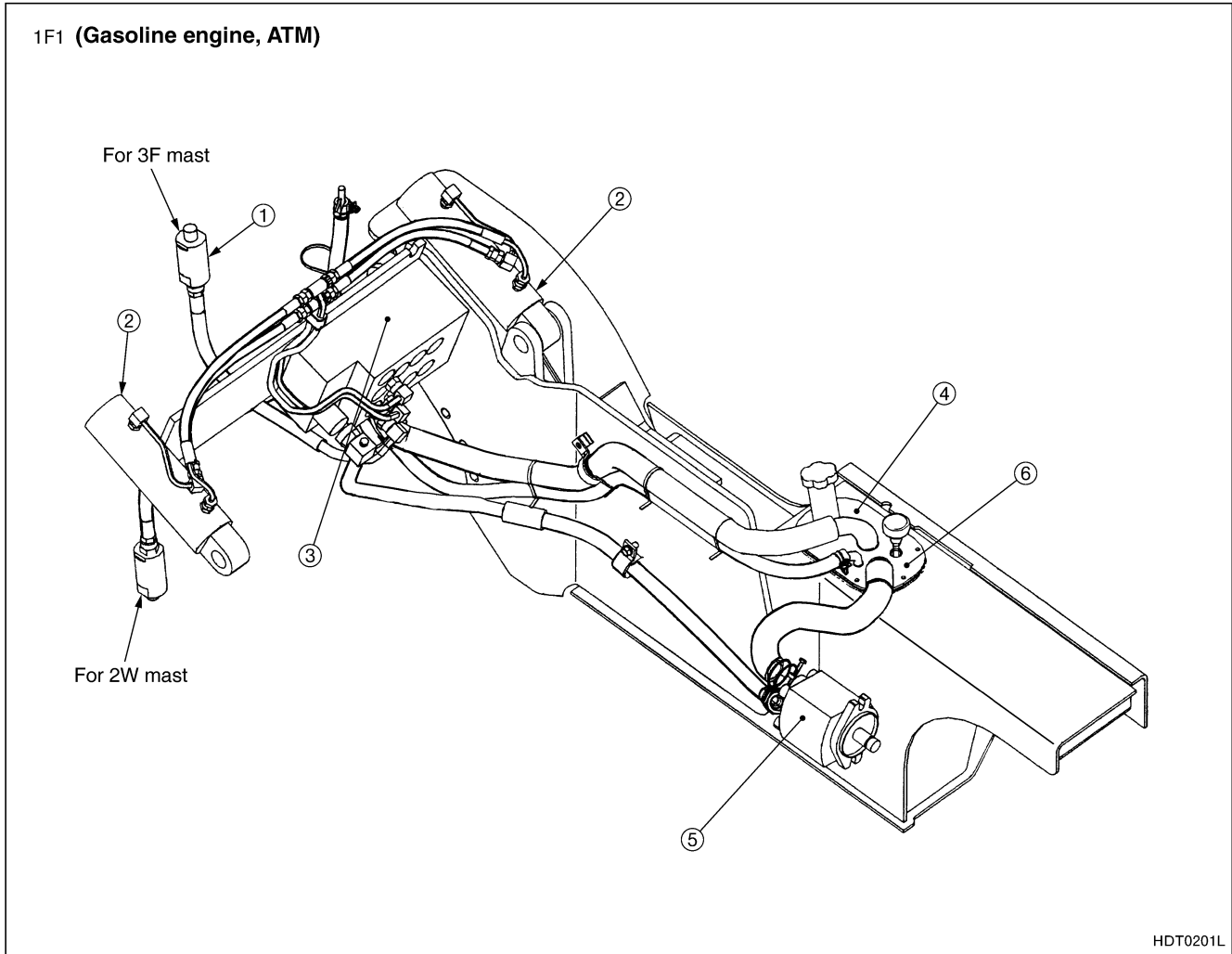

- (1) Flow regulator valve
- (2) Tilt cylinder
- (3) Control valve

- (4) Micron filter (within tank)
- (5) Hydraulic pump
- (6) Suction filter (within tank)

Screw tightening torque [N•m (kg-m) Ft./Lbs]:

G1/4 19.7 - 39.2 (2 - 4) 15 - 29

G3/8 29.5 - 58.8 (3 - 6) 22 - 43

G1/2 58.9 - 98.0 (6 - 10) 44 - 72

PS flow dividing valve built in the control valve. For this reason, oil pressure is supplied to a control valve for piping of one from a pump. In addition, steering box is supplied via control valve.

HYDRAULIC PUMP

HYDRAULIC PUMP

Component Parts Location

SGP1 type

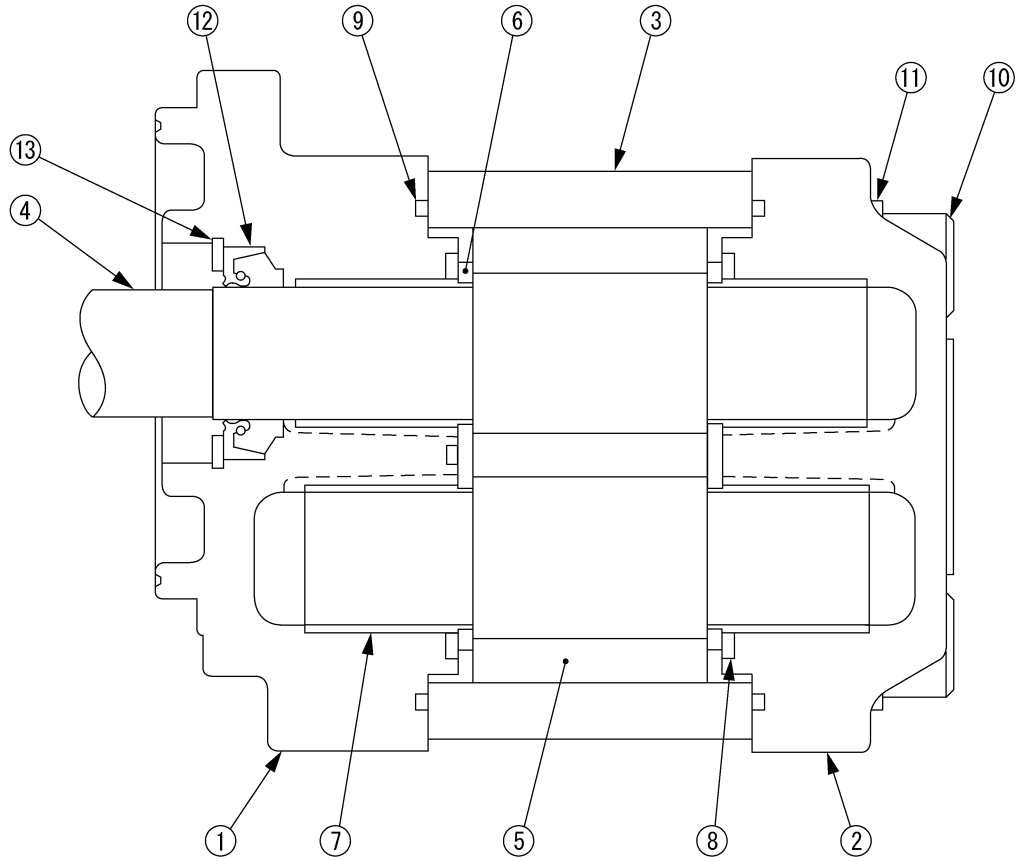

① Front cover

② Rear cover

③ Body

④ Drive gear

⑤ Driven gear

⑥ Side plate

⑦ Bushing

⑧ 3-shape gasket

⑨ Gasket

⑩ Bolt with hexagon hole

⑪ Washer

⑫ Oil seal

⑬ Retaining ring

HDT0207L

CONTROL VALVE

7. Function

While the operator is not seated on the seat, the fork will not tilt forward even if the cargo lever is moved to the forward tilt position. (The engine is idling.)

8. System

- The unload valve inside the cargo control valve routes the hydraulic pressure to the bypass circuit while the operator is not seated. In an idling state, this prevents the cargo control valve pressure from building up and thus locks the tilt lock valve.
- When the seat switch turns ON (operator is seated), the unload valve closes the bypass circuit and allows the tilt lock valve to be released.



CAUTION:

- **In a fast idle state, the increased internal pressure of the cargo control valve releases the tilt lock valve, canceling the tilt lock function.**

NOTE:

This function may be effective against the following risks

- When the operator gets on or off the vehicle, a part of the operator's body inadvertently pushes the tilt lever, almost dropping the cargo from the fork.



CAUTION:

- **The seat switch turns OFF only 3 seconds after the operator is unseated. This is to prevent any abrupt stop of cargo handling operations due to the above protective function. Keep in mind that the tilt lock function will not work for 3 seconds after standing up from the seat.**

(4) Removal

1. Tilt the mast fully backward and lower the mast to the lowest stop.
2. Return the mast to the neutral position.
3. Turn the key switch to ON (do not start the engine) and release the residual pressure from the piping.



CAUTION:

- **Ensure that no foreign materials get into the piping and control valve.**
- **The control valve is heavy. When removing it, hold it carefully and securely so that it will not slip from hands.**

(5) Disassembly



CAUTION:

- **Do not disassemble the main relief valve assembly. It must be replaced as an assembly.**
- **Do not loosen the lock nut. If it is loosened, the set pressure must always be adjusted after assembly and installation.**
- **Do not loosen the poppet (load check) and poppet spring located on the inlet housing-to-outlet housing interface.**

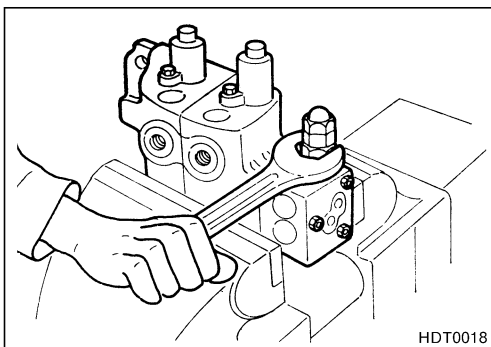

LIFT (MAST) CYLINDER

(7) Mast Cylinder (3F Mast) Inner Part Drain Method

Component Parts Location

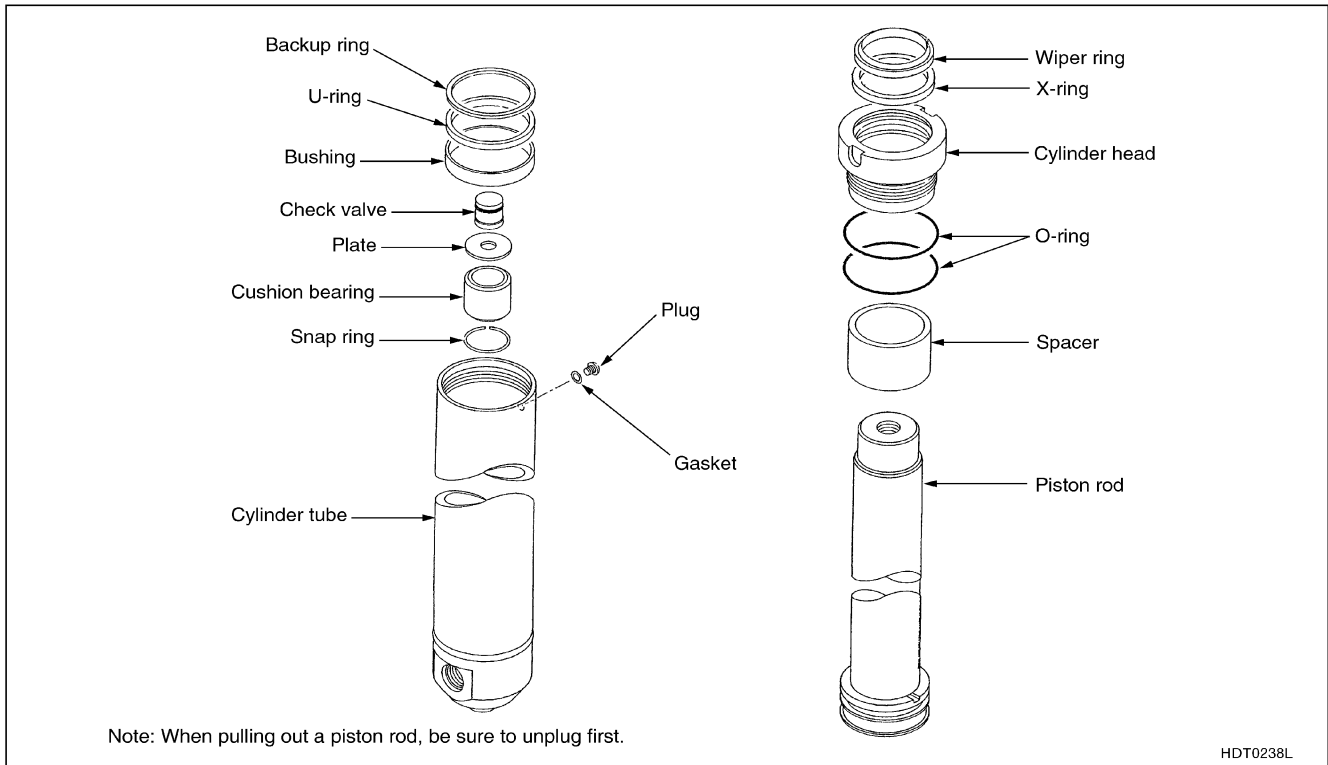

(8) Full Free Cylinder (2F, 3F Mast)

Component Parts Location

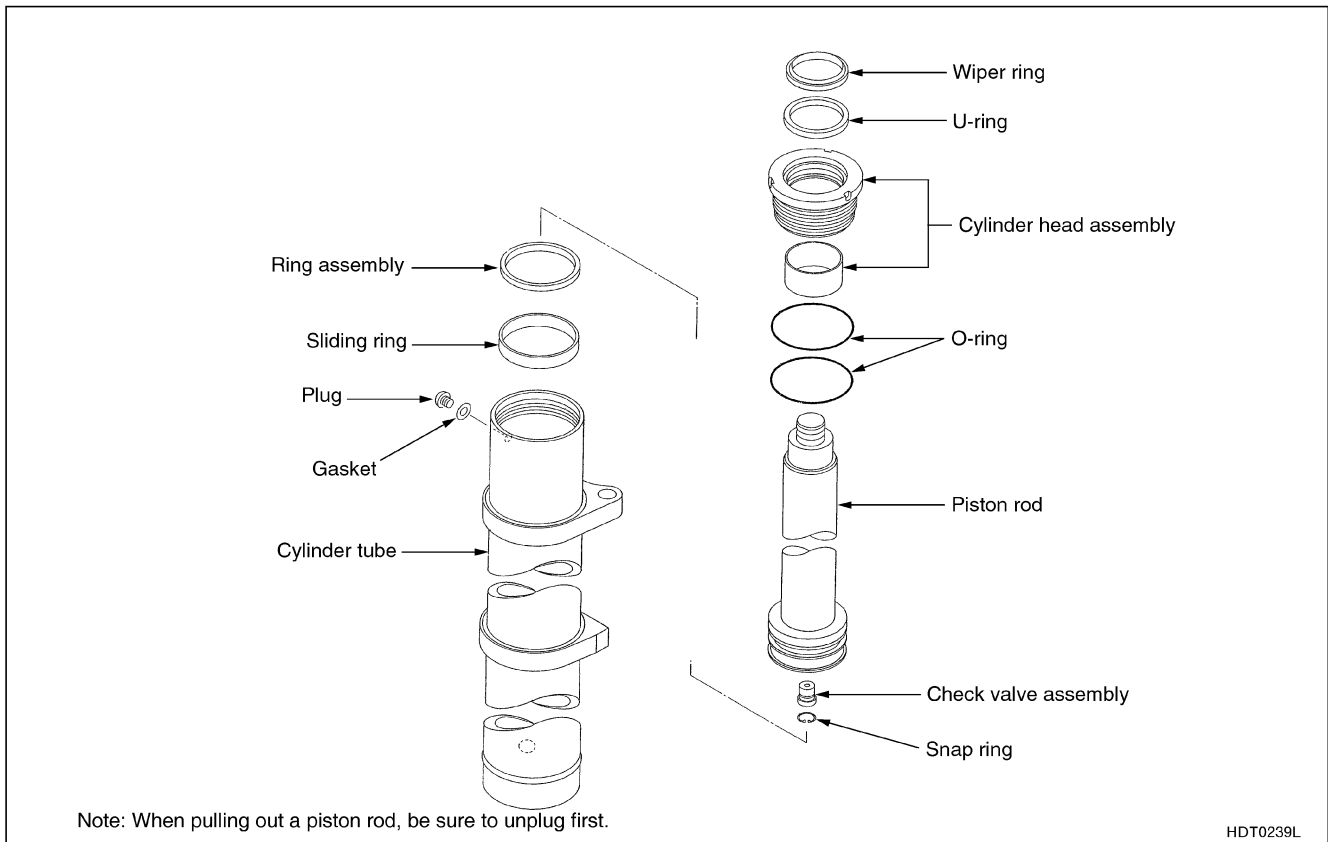

6 . REPLACEMENT OF HYDRAULIC FLUID

(1) Inspection

Dirt or deterioration of hydraulic fluid causes malfunction of control valve. Hydraulic oil must be replaced per maintenance schedule.



CAUTION:

- Hydraulic oil of wet type clutch vehicle shall be used in common with clutch disc oil for cooling. (Oil for use: HDS-3-10w/ Diesel engine oil)

Periodically replacement of standard hydraulic fluid level	Every 6 months or 1,200 hours H level of tank unit value (Oil for use: NISSAN HYDRAULIC FLUID)	Vehicle model Items	1F1 type		1F2 type	
			1.0 ton model	1.5, 1.75, 2.0 ton model	2.0, 2.5 ton model	2.75, 3.0, 3.5 ton model
		Total amount	Approx. 38 ℓ 40.2 Qts	Approx. 39 ℓ 41.2 Qts.	Approx. 50 ℓ 52.9 Qts.	Approx. 54 ℓ 57.1 Qts
		Within tank	Approx. 30 ℓ 31.7 Qts.	Approx. 30 ℓ 31.7 Qts	Approx. 44 ℓ 46.5 Qts.	Approx. 48 ℓ 50.7 Qts

Replacement procedures

1. Start engine, raise lift cylinder full stroke.
2. Control lever is returned neutrally, engine is stopped and the lift cylinder upper side hose is removed.
3. Control lever is operated to lift cylinder descent, a lift cylinder is dropped gradually, and the oil in a lift cylinder is returned to a tank.
4. Remove tank drain plug and drain the oil.
5. Install drain plug of each hose and tank, fill in new hydraulic fluid.
6. When hydraulic fluid is replaced, following the instructions below.



CAUTION:

- Deposition dust in tank must be completely cleaning. (Remove drain plug under side.)
- Clean suction filter and hydraulic fluid cap.
- Oil level should supply with oil to come in the middle of the maximum line of a level gauge, and a minimum line, when oil has entered in piping, hydraulic power unit.

7 . HYDRAULIC PIPING

Installing after removal hydraulic pipe, follow the instruction below.



CAUTION:

- Make sure to seal the taper threads using a seal tape. Do not allow seal tape fragments etc. to enter hydraulic pipes.
- The hydraulic units use an O-ring seal at the couplings. When attaching an O-ring, always use an O-ring guide over the coupling thread so that the O-ring is not damaged. When connecting a coupling, first tighten the lock nut by hand so that the coupling and the pipe are aligned correctly. Then tighten the lock nut to the specified torque.
- Tightening torque is as the torque shown in "5. HYDRAULIC PIPING".

MAST

Mast Assembly

2H MAST

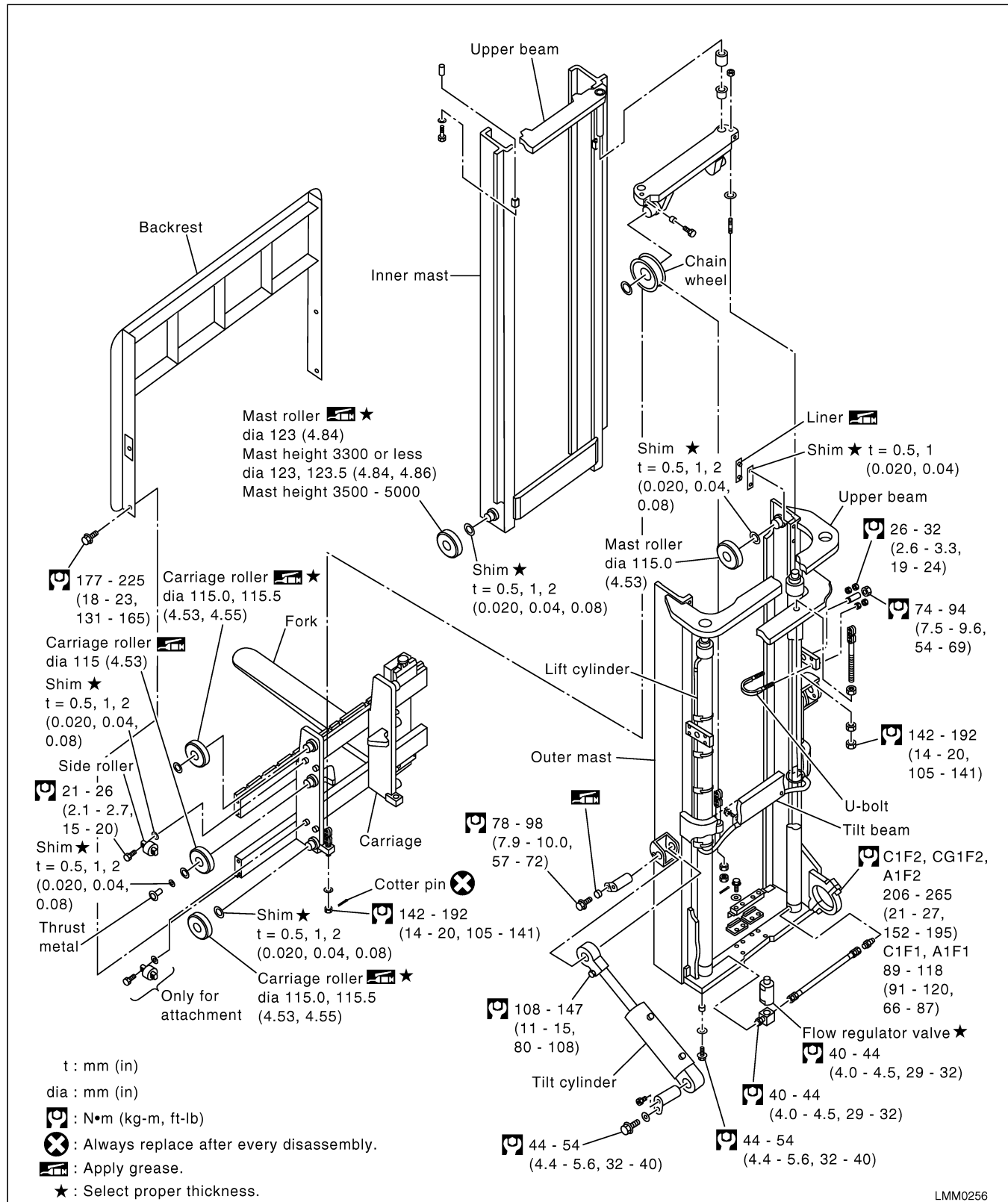

LMM0256

Assembly (Cont'd)

<ADJUSTMENT OF MAST INSTALLED TO VEHICLE>

3F/3V MAST

- Hang the mast using a wire, etc., and remove the carriage assembly. Refer to “CARRIAGE ASSEMBLY”.
 - Remove mast chain.
 - Remove master cylinder. Refer to HD section.
 - Lower the inner mast by approximately 120 mm (4.72 in), replace the liner of the middle mast side, and then perform the shim adjustment.
 - Lower the inner mast and middle mast simultaneously for approximately 120 mm (4.72 in), replace the liner of the outer mast side, and then perform the shim adjustment.
4. Install the inner mast roller, mast roller of the middle mast lower side, and perform the shim adjustment with the following procedure.
- Set the roller pitches (Dimension “L”) of the inner mast, middle mast (3F/3V mast), and outer mast to the dimensions indicated in the table according to the mast lifting height.

Unit: mm (in)

Lifting height		Dimension “L”		
		A1F1, A1F2, C1F1, C1F2, 1F1, 1F2	CG1F2, G1F2	
3F	3850, 4300 (151.57, 169.29)	369 (14.53)	519 (20.43)	
	4750 (187.01)		504 (19.84)	
	5154 (202.91)		494 (19.45)	
	5500 (216.54)	384 (15.12)	574 (22.60)	
	6000 (236.22)	419 (16.50)	669 (26.34)	
	6500 (255.91)	504 (19.84)	754 (29.68)	
	7000 (275.59)	604 (23.78)	854 (33.62)	
	3.5 ton	3550, 4000, 4450, 4854 (139.75, 157.46, 175.20, 191.10)	—	469 (18.46)
		5200 (204.72)		484 (19.06)
		5700 (224.41)		519 (20.43)
6200 (244.09)		604 (23.78)		
6700 (263.78)		704 (27.72)		
3V	3600, 4050, 4500, 4800 (141.73, 159.45, 177.17, 192.91)	369 (14.53)		
	5250 (206.69)	384 (15.12)		
	5750 (226.38)	419 (16.50)		
	6330 (249.21)	504 (19.84)		
	6880 (270.87)	604 (23.78)		
	3.0, 3.5 ton	3850, 4300, 4700 (151.57, 169.29, 185.04)	—	469 (18.46)
		5050 (198.82)		484 (19.06)
		5550 (218.50)		519 (20.43)
		6000 (236.22)		609 (23.98)
		6500 (255.91)		794 (31.26)
7000 (275.59)		854 (33.26)		

HOSE CONNECTION LAYOUT FOR ELECTRICALLY CONTROLLED LPG

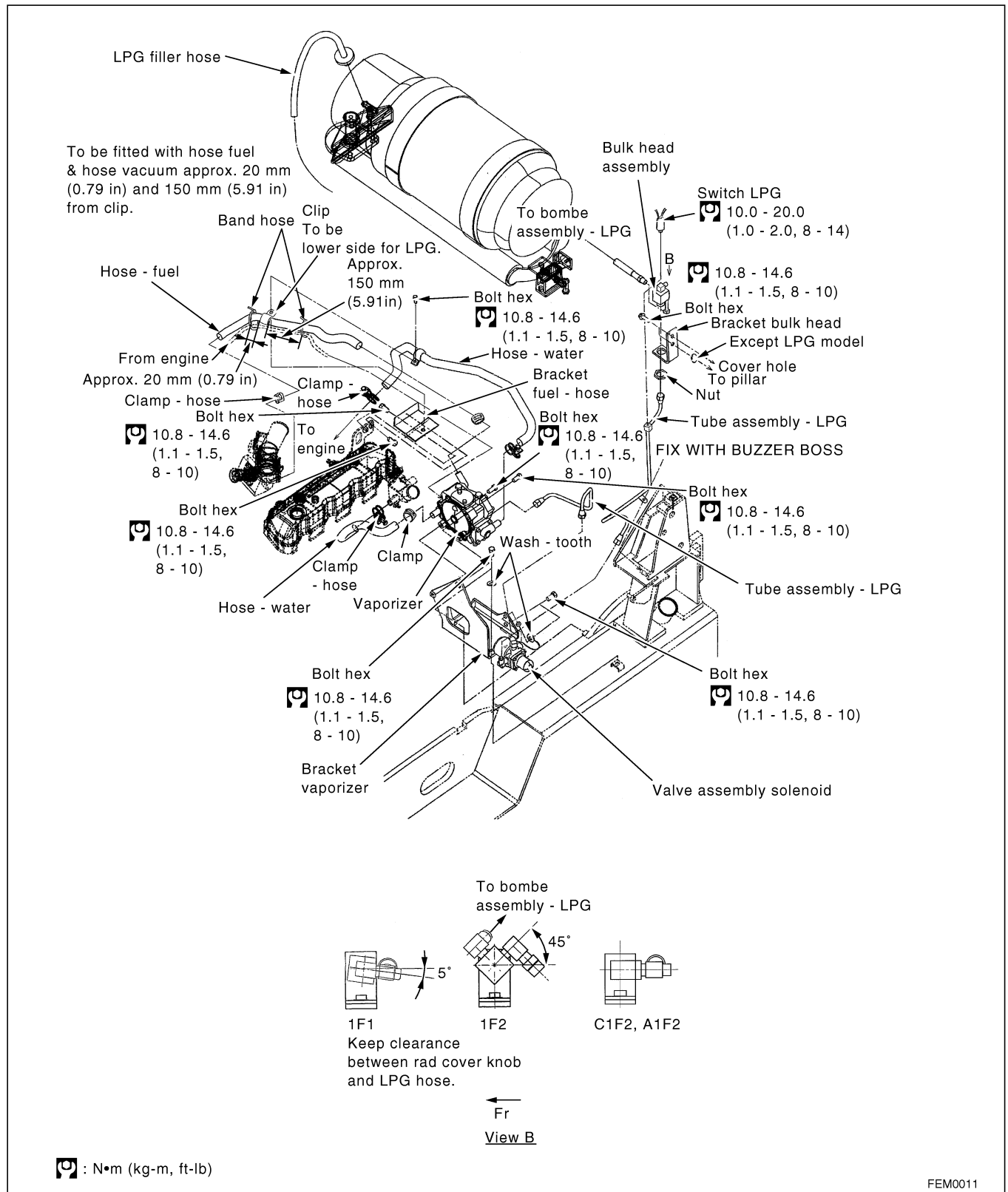

FEM0011

OVERHEAD MUFFLER SYSTEM (OPTION) (QD32 ENGINE)

Operation (cont'd)

The purpose of the warning light and buzzer is to inform the truck operator when the LPG Tank Swing Bracket Assembly is in the LOCKED or UNLOCKED position.

WARNING LIGHT AND BUZZER "OFF" INDICATES **LOCKED** POSITION.
WARNING LIGHT AND BUZZER "ON" INDICATES **UNLOCKED** POSITION.

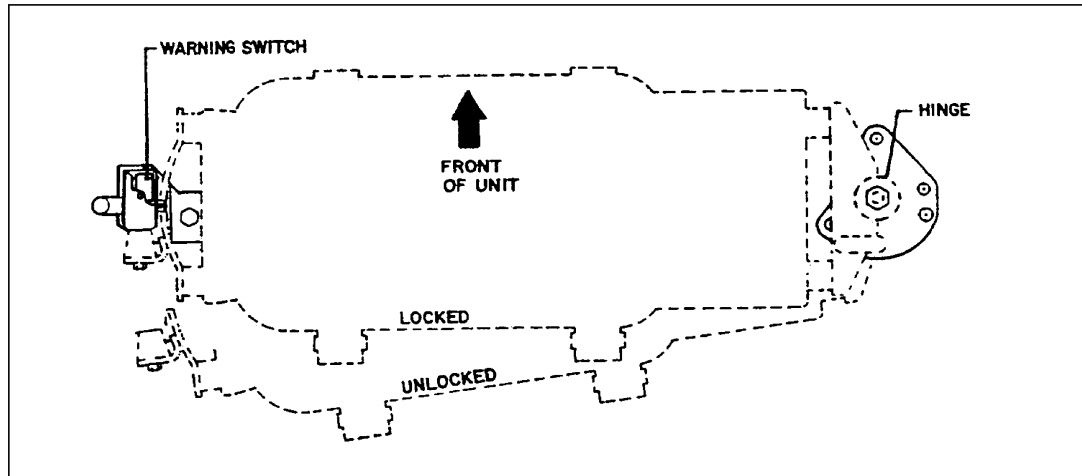

WARNING:

The warning light and buzzer must be "OFF" before the truck should or can be operated.

(2) Adjustments

1. Ensure latch pin is fully engaged and that the swing bracket assembly cannot move.
2. Loosen two (2) latch assembly mounting bolts.

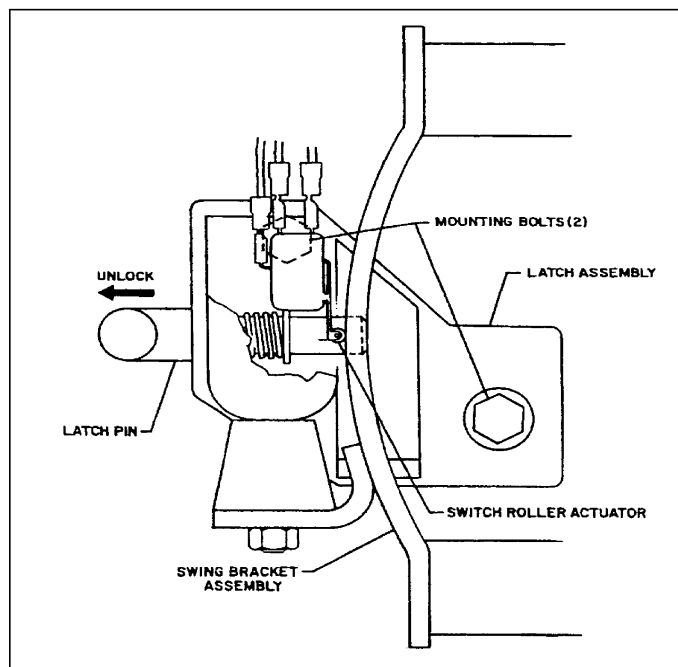

PRECAUTIONS

Precaution (Cont'd)

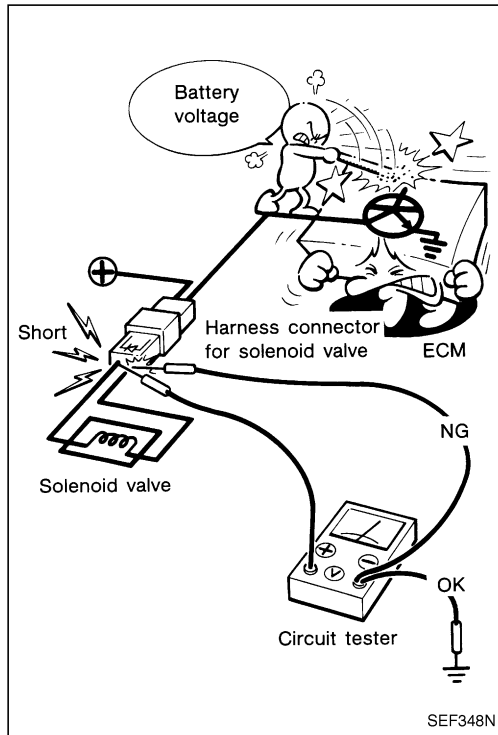

- When measuring ECM signals with a circuit tester, never allow the two tester probes to contact. Accidental contact of probes will cause a short circuit and damage the ECM power transistor.
- Do not use ECM ground terminals when measuring input/output voltage. Doing so may result in damage to the ECM's transistor. Use a ground other than ECM terminals, such as the ground.

- Do not operate fuel pump when there is no fuel in lines.
- Tighten fuel hose clamps to the specified torque.

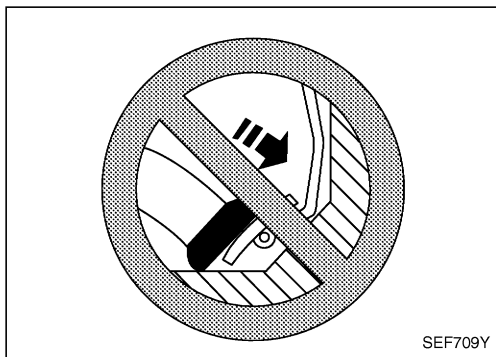

- Do not depress accelerator pedal when starting.
- Immediately after starting, do not rev up engine unnecessarily.
- Do not rev up engine just prior to shutdown.

TROUBLE DIAGNOSIS

ECM Component (Cont'd)

Mass air flow sensor, fuel injector (GAS),
ignition coil, fuel pressure sensor, LPG
main injector, LPG assistance injector

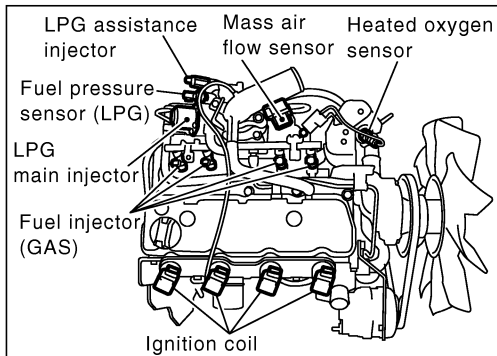

Electric throttle control actuator

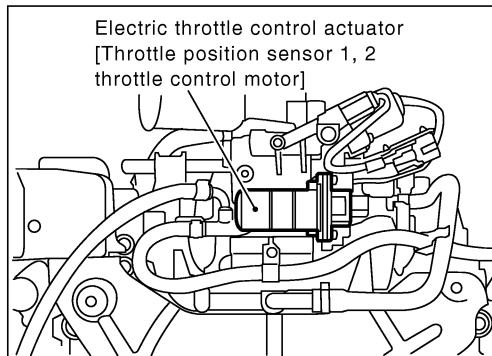

Fuel pump

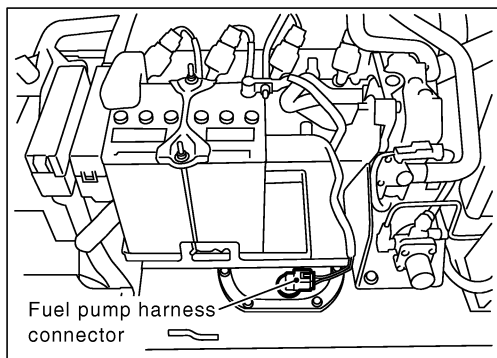

Relay box 2, fuse box

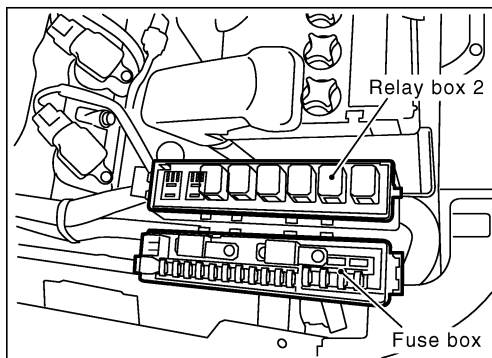

Stop lamp switch

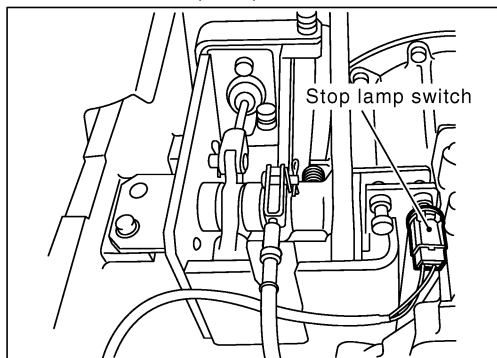

Relay box 1

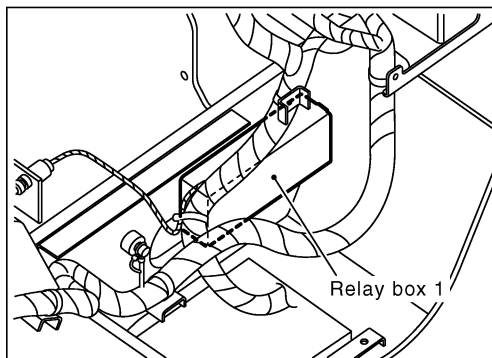

ECM0426

TROUBLE DIAGNOSIS

How to Proceed with Trouble Diagnosis (Cont'd)

TROUBLE DIAGNOSIS FLOW CHART

There are many different malfunction symptoms. So there is no perfect trouble diagnosis technique applicable to all malfunctions. Experience is also important to achieving an accurate trouble diagnosis.

Nonetheless, an accurate trouble diagnosis can be performed by applying similar procedures, regardless of the malfunction symptom. Perform trouble diagnosis following the flow chart shown below.

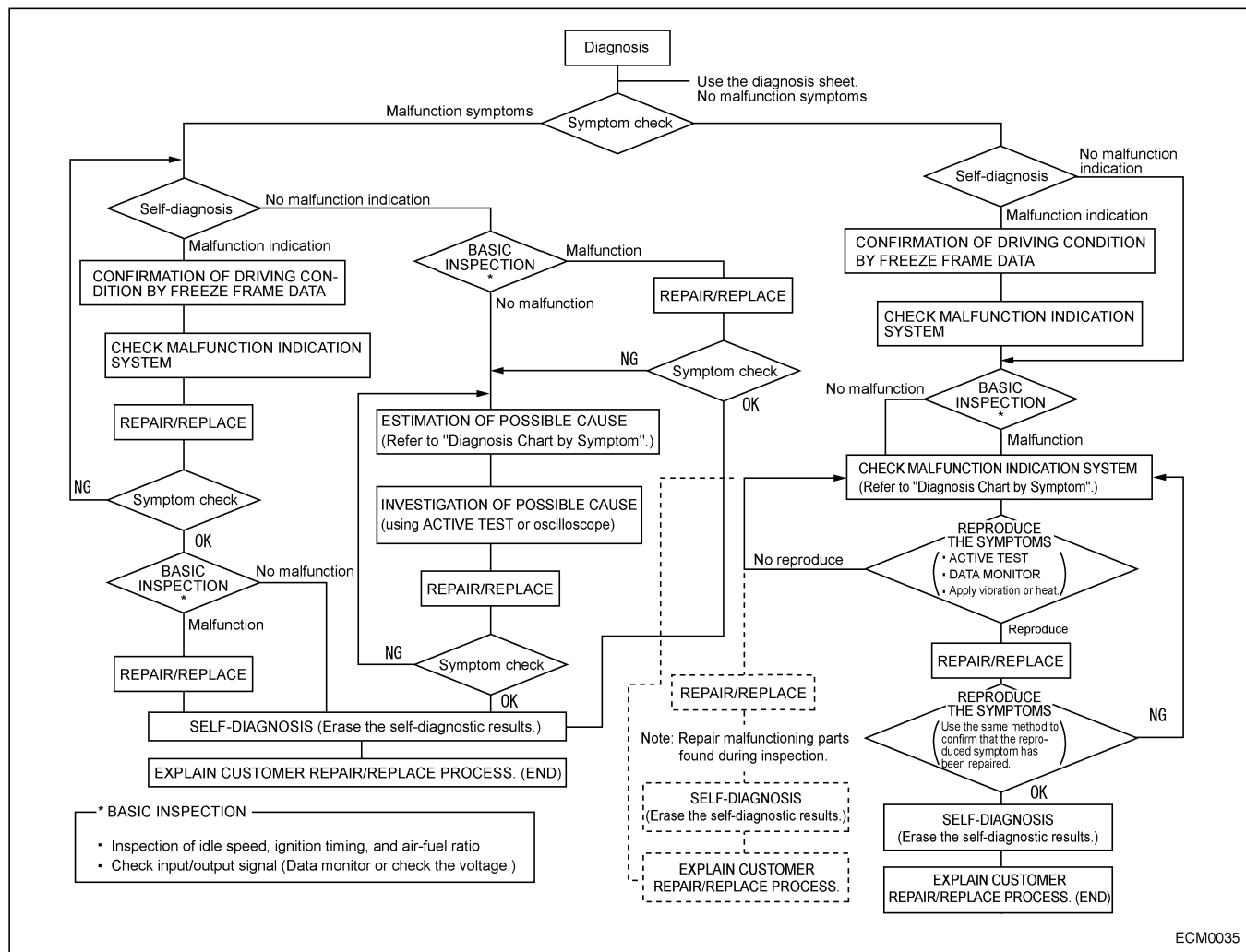

Question point
• WHAT Vehicle & engine model
• WHEN Date, Frequencies
• WHERE Road conditions
• HOW Operating conditions, Weather conditions
• WHAT BECAME Symptom

ECM0036

DIAGNOSTIC WORK SHEET

Description

- In order to clarify the malfunction symptom, it is important to ask the customer and collect information about their concerns.
- Ask the customer about what symptoms are present under what conditions. Use the information to clarify the symptom.
- Use the trouble diagnosis sheet to be certain not to miss any vital information.

TROUBLE DIAGNOSIS

Table of DTC (Cont'd)

DTC for GST	Malfunction return condition	Diagnosis outline	Trip
—	—	—	—
U1001	<ul style="list-style-type: none"> • Malfunction occurs in CAN communication transmit/receive data or in VCM, and data transmission/reception cannot be confirmed. • CAN communication data is transmitted/received for predetermined period. 	—	2
U1001	<ul style="list-style-type: none"> • Malfunction occurs in CAN communication transmit/receive data or in ECM, and data transmission/reception cannot be confirmed. • CAN communication data is transmitted/received for predetermined period. 	—	2
U1001	<ul style="list-style-type: none"> • Malfunction occurs in CAN communication transmit/receive data or in DCM, and data transmission/reception cannot be confirmed. • CAN communication data is transmitted/received for predetermined period. 	—	2
U1001	<ul style="list-style-type: none"> • Malfunction occurs in CAN communication transmit/receive data or in MP, and data transmission/reception cannot be confirmed. • CAN communication data is transmitted/received for predetermined period. 	—	2
P0102	When the engine is running and the mass air flow sensor output voltage has been 0.5V or less (open or shorted) for a predetermined period.	Detect disconnection and short circuit and make MIL go on.	1
P0103	When the engine is stopped (ignition switch ON) and the mass air flow sensor output voltage has been approx. 4.9V or more (open or shorted) for a predetermined period.		
P0117	Engine coolant temp. sensor output voltage has been less than 0.06V (open or shorted) for a predetermined period.	Detect disconnection and short circuit and make MIL go on.	1
P0118	Engine coolant temp. sensor output voltage has been approx. 4.8V or more (open or shorted) for a predetermined period.		

TROUBLE DIAGNOSIS

Self-Diagnosis Function (Without Service tool)

[Diagnostic test mode II (self-diagnostic results) starting procedure]

- 1 Turn ignition switch ON with accelerator pedal released.
- 2 After 3 seconds, fully depress accelerator pedal and then release it. Quickly repeat this cycle 5 times within 5 seconds (end in released position).
- 3 Fully depress accelerator pedal 7 seconds after releasing it, and keep that position approximately 10 seconds (until MIL blinks). Diagnostic test mode II self-diagnostic results starts.
- 4 Return accelerator pedal. Execute self-diagnosis.
 - Perform self-diagnosis with ignition switch ON. [Diagnostic test mode II (self-diagnostic results)]
 - Starting engine in Diagnostic test mode II (self-diagnostic results) opens heated oxygen sensor monitor. [Diagnostic test mode II (heated oxygen sensor monitor)]
 - Turning ignition switch OFF returns to mode 1 automatically. [Normal condition]

CAUTION: Count time accurately with watch or equivalent.

If mode 1 does not turn to mode 2, turn ignition switch OFF and wait for at least 10 seconds.

[Self-diagnosis results erasing procedure]

- 1 Fully depress accelerator pedal in Diagnostic test mode II (self-diagnostic results), and keep the position at least 10 seconds. Self-diagnostic results are erased.
 - Release accelerator pedal. Make sure self-diagnostic results are erased.
 - Turning ignition switch OFF returns to mode 1.

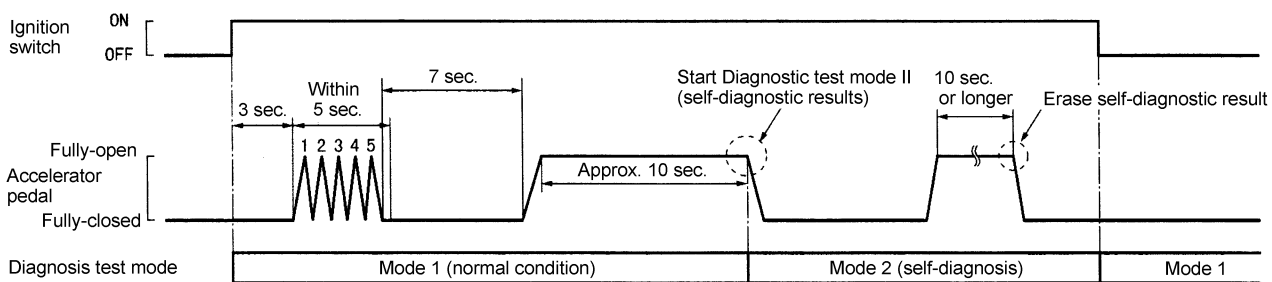

ECM0078

DIAGNOSTIC TEST MODE II - SELF-DIAGNOSTIC RESULTS

- In this mode, the MIL blinks (indicating the DTC) to identify the system that returned a malfunction.
- If no DTC is detected, DTC "0000" is displayed.

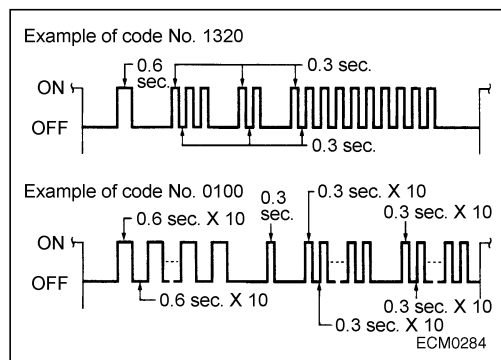

BASIC INSPECTION

Inspection of Idle Speed and Ignition Timing

SERVICE DATA AND SPECIFICATIONS (SDS)

Fuel pressure [(kPa, bar, kg/cm ² , psi)]		0.35 (0.0035, 0.0036, 0.051)
Idle speed (rpm)	A/T model (at N position)	700±50
Ignition timing (°BTDC/rpm)	A/T model (at N position)	0±2/700
Firing order		1-3-4-2
Spark plug	Manufacturer/type/gap mm (in)	NGK/FR2A-D/0.8 - 0.9 (0.0031 - 0.035)
Ignition advance device		Electrically controlled ignition advance
Density of CO at idle speed (%)/Density of HC at idle speed (ppm)		0.1/50 or less

- Turn ignition switch ON, and then make sure that no malfunction is detected by self-diagnosis.
- Make sure that engine is free of oil pressure pump loads and any electrical loads. Perform the inspection with the shift lever in the neutral or N position.
- Warm up engine and transmission to the normal operating temperature.

IDLE SPEED

With ECM Input/Output monitor

NOTE:

The idle speed can be checked in ECM Input/Output Monitor. (Refer to EC-46.)



CAUTION:

Perform "Idle Air Volume Learning" (on page EC-48) when idle speed is outside the standard.

Without ECM Input/Output monitor

1. Connect an induction type (current detection type) tachometer to the primary wire of the 1 cylinder to check idle speed.
 - The primary wire for the 1 cylinder is looped and longer than the wires for other cylinders. It is used for detecting idle speed and ignition timing.
2. Make sure that idle speed is 700 ±50 rpm.



CAUTION:

Perform "Idle Air Volume Learning" (on page EC-48) when idle speed is outside the standard.

IGNITION TIMING INSPECTION

NOTE:

The ignition timing can be checked in ECM Input/Output monitor. (Refer to EC-46.)

1. Install a timing light to the primary wire for 1 cylinder.
2. Make sure that ignition timing and idle speed are 0 ±2°BTDC/700 rpm.



CAUTION:

Perform "Idle Air Volume Learning" (on page EC-48) when ignition timing is outside the standard.

PCV GAS RECIRCULATION DEVICE

System Diagram

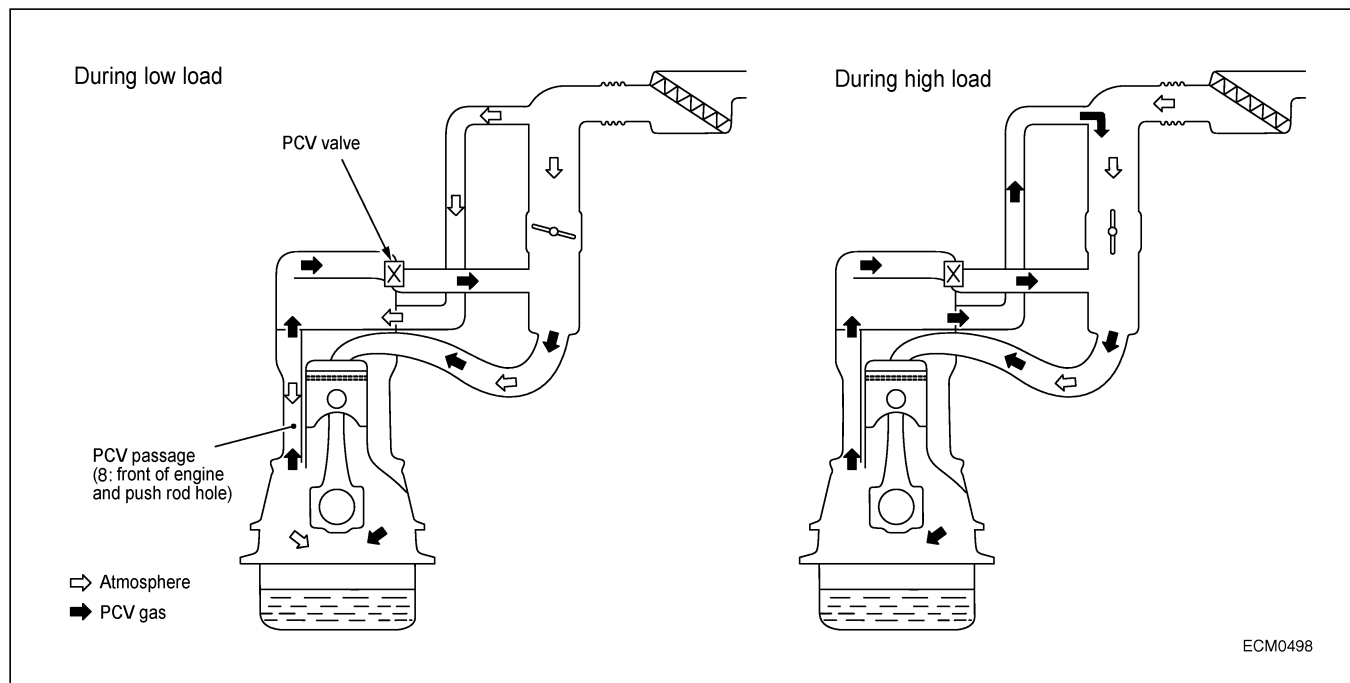

Component Parts Inspection

PCV valve

1. At idle, remove PCV valve together with hoses from rocker cover.
2. Check if hissing sound is heard from the air passage when PCV valve is operating normally.
3. Check air flow through the PCV valve and sucking air to/from the INT end.
Blowing air: No air flow
Sucking air: Air flow exists

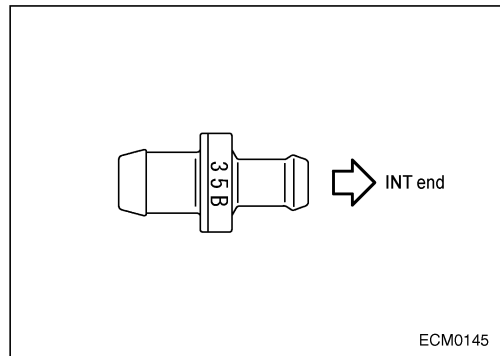
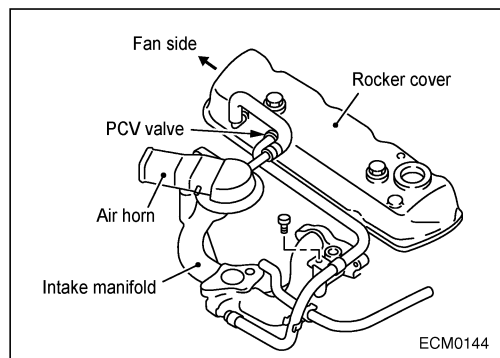

VEHICLE CONTROL SYSTEM

Vehicle Control System (Cont'd)

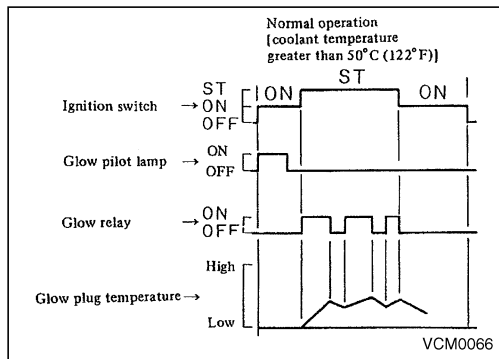

3. Ignition switch "START".

The "chopping-ON time" and "chopping-OFF time" durations are the same as those previously outlined under the topic "Coolant temperature below 50°C (122°F)".

PARKING BRAKE WARNING BUZZER

A warning buzzer sounds when the driver stands up from the seat without applying the parking brake.

Ignition switch	Seat		Parking brake		Warning buzzer
	Seated	Unseated	Applied	Released	
ON	○	—	○	—	×
	○	—	—	○	×
	—	○	○	—	×
	—	○	—	○	○
OFF	○	—	○	—	×
	○	—	—	○	○
	—	○	○	—	×
	—	○	—	○	○

NOTE:

3-second delay is implemented for detection of unseated status.

Input	Output
Parking brake switch (CAN data)	Warning buzzer
Seat switch	

MAST LOCK

This locks the cargo handling equipment while the operator is not seated in the driver seat.

Operator	Mast lock	Mast interlock indicator lamp
Seated	×	×
Unseated	○	lighting

NOTE:

3-second delay is implemented for detection of unseated status.

(When the operator unseats himself from the driver seat, the current cargo operation will be stopped after 3 seconds.)

Input	Output
Seat switch	Mast interlock indicator lamp (CAN data)
	C/V unload solenoid (MC)
	C/V lift lock solenoid (MC)
	C/V proportional solenoid (FC)

CLICK HERE TO **DOWNLOAD** THE COMPLETE MANUAL

- Thank you very much for reading the preview of the manual.
- You can download the complete manual from: www.heydownloads.com by clicking the link below





- Please note: If there is no response to CLICKING the link, please download this PDF first and then click on it.

CLICK HERE TO **DOWNLOAD** THE COMPLETE MANUAL

COMBINATION METER

Fuel Gauge

Fuel	Indication	Level
Full ↓ Empty	E ██████ F	Level 5
	E ██████▬ F	Level 4
	E █████▬▬ F	Level 3
	E ███▬▬▬ F	Level 2
	E █▬▬▬▬ F	Level 1
	E  ▬▬▬▬ F + 	Level 0

VCM0075

Indicates the current fuel level in levels 0 - 5.

When level 5 is indicated, the fuel tank is full.

When the indication reaches level 0, the display begins to blink, and the multipurpose warning lamp illuminates to inform the operator of the nearly empty fuel tank. The fuel tank is nearly empty. Add fuel immediately.

NOTE:

- If the forklift is an LPG - gasoline dual fuel vehicle, the fuel meter will not work when the forklift is operated with LPG.
- When operating the forklift with LPG, check from time to time to be sure that the LPG level warning lamp is not lit and that the LPG level alarm is not on.
- To check the remaining amount of LPG, use the fuel gauge on the LPG cylinder.

COMBINATION METER

LPG Remaining Time Management (Cont'd)

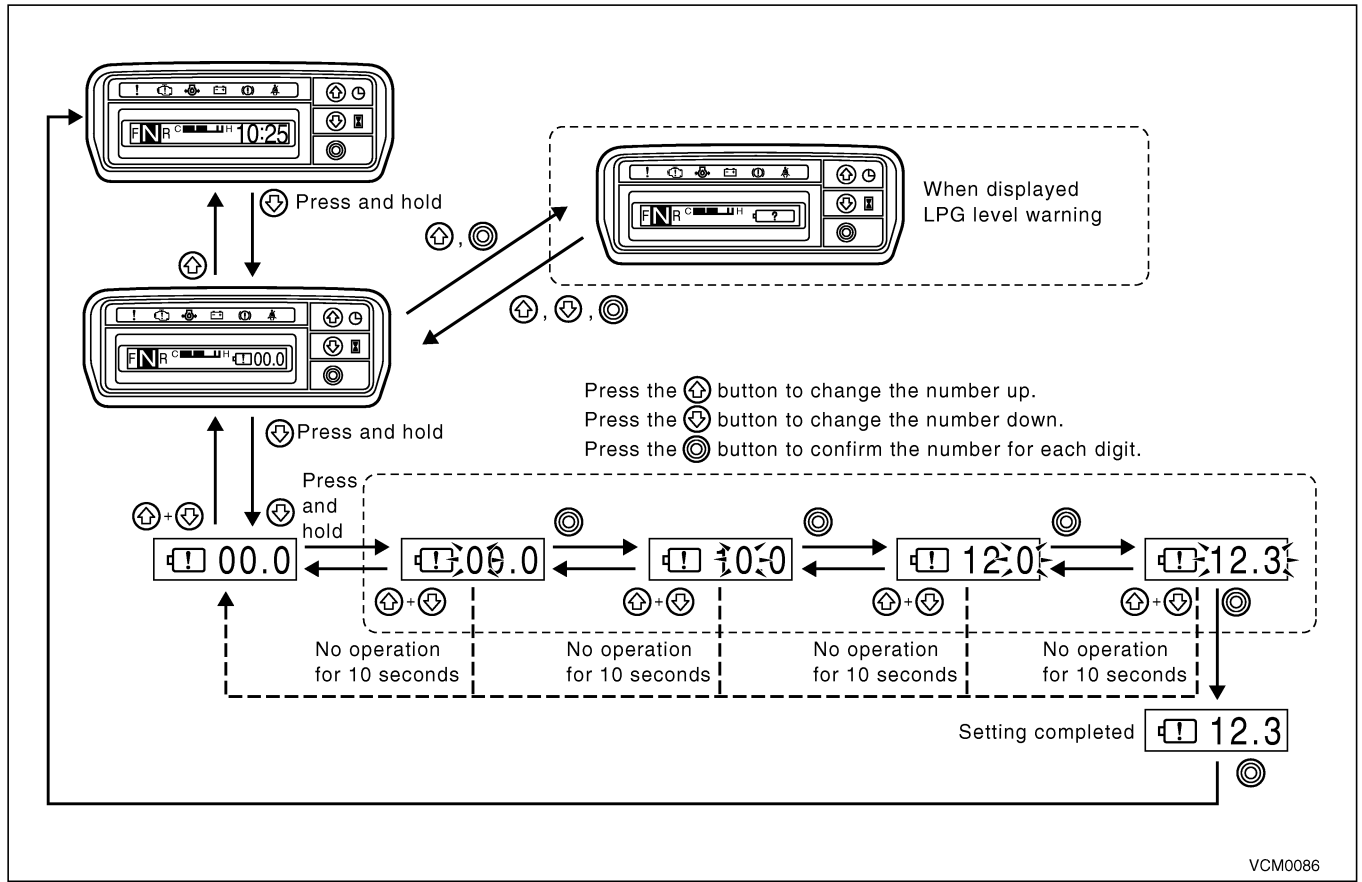

NOTE:

Following is an explanation of how to set the time setting for the first time.

Example: Setting the time to 12.3 hours

COMBINATION METER

Fault Adjustment Diagnostic Mode (Cont'd)

Item	Name of item	Setting value	Content
B1-01 (Upper)	Controller type for cargo control valve	MC/FC1/FC2/ MFC	(Controller type) MC : Mechanical valve FC1 : Proportional solenoid valve (TWIN lever) FC2 : Proportional solenoid valve (SINGLE lever) MFC : Proportional solenoid valve (Multifunction lever) (Not specified)
B1-01 (Lower)	Transmission type	MTM/ATM/ 2ATM	(Transmission type) MTM : Clutch ATM : 1st speed torque-converter 2ATM : 2nd speed torque converter
B1-02 (Upper)	Engine type	ELEG.L/ NELEG.L/ ELEG/NELEG/ ELEL/NELEL/ D(QD32)/ D(S4Q2)/ D(TD42)	(Engine type) ELEG.L : Electronically controlled gasoline/LPG NELEG.L : Non-electronically controlled gasoline/LPG ELEG : Electronically controlled gasoline NELEG : Non-electronically controlled gasoline ELEL : Electronically controlled LPG NELEL : Non-electronically controlled LPG D(QD32) : Diesel (QD32) D(S4Q2) : Diesel (S4Q2) D(TD42) : Diesel (TD42) (Not specified)
B1-02 (Lower)	Cargo lever limit switch	OFF/ON	(Cargo lever limit switch setting for MC models) For (tilt leveling control or 4/5-series valve) and (MC models), set to ON
B1-03 (Upper)	Cargo control valve series number	2V/3V/4V/5V	(Series number of control valve) 2V : 2 spools 3V : 3 spools 4V : 4 spools 5V : 5 spools *Used for FC control
B1-03 (Lower)	Load capacity (ton)	1t/2~3t/3~5t/ C1t/C2~3t	(Load capacity [ton]) 1t : Pneumatic 1t 2-3t : Pneumatic 2-3t 3-5t : Pneumatic 3-5t C1t : Cushion 1t C2-3t : Cushion 2-3t (Used for FC control, knob position correction control (without NFC specification))
B1-04 (Upper)	ECM controller with/without	ON/OFF	with/without of ECM
B1-04 (Lower)	DCM controller with/without	ON/OFF	with/without of DCM (Not specified)
B1-05 (Upper)	Maximum speed regulation control	ON/OFF	Setting of maximum vehicle speed control
B1-05 (Lower)	Tilt leveling control	ON/OFF	Setting of tilt leveling control
B1-06 (Upper)	Power eco control	ON/OFF	Setting of power/eco control
B1-06 (Lower)	Auto stop/Auto start	ON/OFF	Setting of auto stop/start (without NFC specification)
B1-07 (Upper)	Loading capacity	ON/OFF	Setting of weight meter (without NFC specification)
B1-07 (Lower)	Speed alarm	ON/OFF	Setting of speed alarm
B1-08 (Upper)	Weight alarm	ON/OFF	Setting of weight alarm (without NFC specification)
B1-08 (Lower)	Auto light control	ON/OFF	Setting of auto light control (without NFC specification)
B1-09 (Upper)	Cylinder diameter	****mm	(Setting of cylinder diameter) *Used for calculation of weight. 1-2t of 1t system (P1, C1, A1): 45 mm 2-2.5t of 2t system (P2, 3, C2, 3, A2): 50 mm 2.75-3t of 2t system: 55 mm 3.3-3.6t of 2t system: 60 mm
B1-09 (Lower)	Gear ratio	***.**dec	(Setting of gear ratio) For the gear ratio list, refer to page VC-40.
B1-10 (Upper)	Speed alarm setting value 1	**.*km/h	Setting of warning vehicle speed for speed alarm (low speed)
B1-10 (Lower)	Speed alarm setting value 2	**.*km/h	Setting of warning vehicle speed for speed alarm (high speed)
B1-11 (Upper)	Weight alarm setting value	**.*t	Warning weight of weight alarm (without NFC specification)
B1-11 (Lower)	Speed limit [out] setting	**.*km/h	Vehicle speed limit of maximum vehicle speed control (high speed)
B1-12 (Upper)	Speed limit [in]	**.*km/h	Vehicle speed limit of maximum vehicle speed control (low speed)
B1-12 (Lower)	Wheel angle center neutral	**.*V	Voltage of wheel angle sensor in the straight-ahead position at knob position correction control (without NFC specification)

NOTE:

Change the setting value: Press ⏪ or ⏩ .

Set the setting value: Press Ⓞ to decide the setting range.

COMBINATION METER

Fault Adjustment Diagnostic Mode (Cont'd) ERROR CODE FOR METER PANEL

Error code	Item	Display
P-03	VCM communication error	C1 **. P-03 *****.* ** VCM COMM ERR
P-04	ECM communication error	C1 **. P-04 *****.* ** ECM COMM ERR
P-05	DCM communication error	C1 **. P-05 *****.* ** DCM COMM ERR
P-07	MP communication error	C1 **. P-07 *****.* ** MP COMM ERR

VCM0099

DESCRIPTION OF DISPLAY FOR DIAGNOSIS HISTORY

The number when the displayed DTC occurs is displayed from the total number of DTC that occurred on the vehicle.

Error code

Operating time of hour meter when the displayed DTC occurred is displayed.

**C1 20.F-38 12376.4
20 TILT SENSOR ERR**

DTC description

VCM0100

ECM Active Test (Cont'd)

AIR-FUEL RATIO ADJUSTMENT:

CHANGE THE ADJUSTMENT VALUE FROM 85 DEC TO 100 DEC, AND THEN ADJUST AIR-FUEL RATIO.

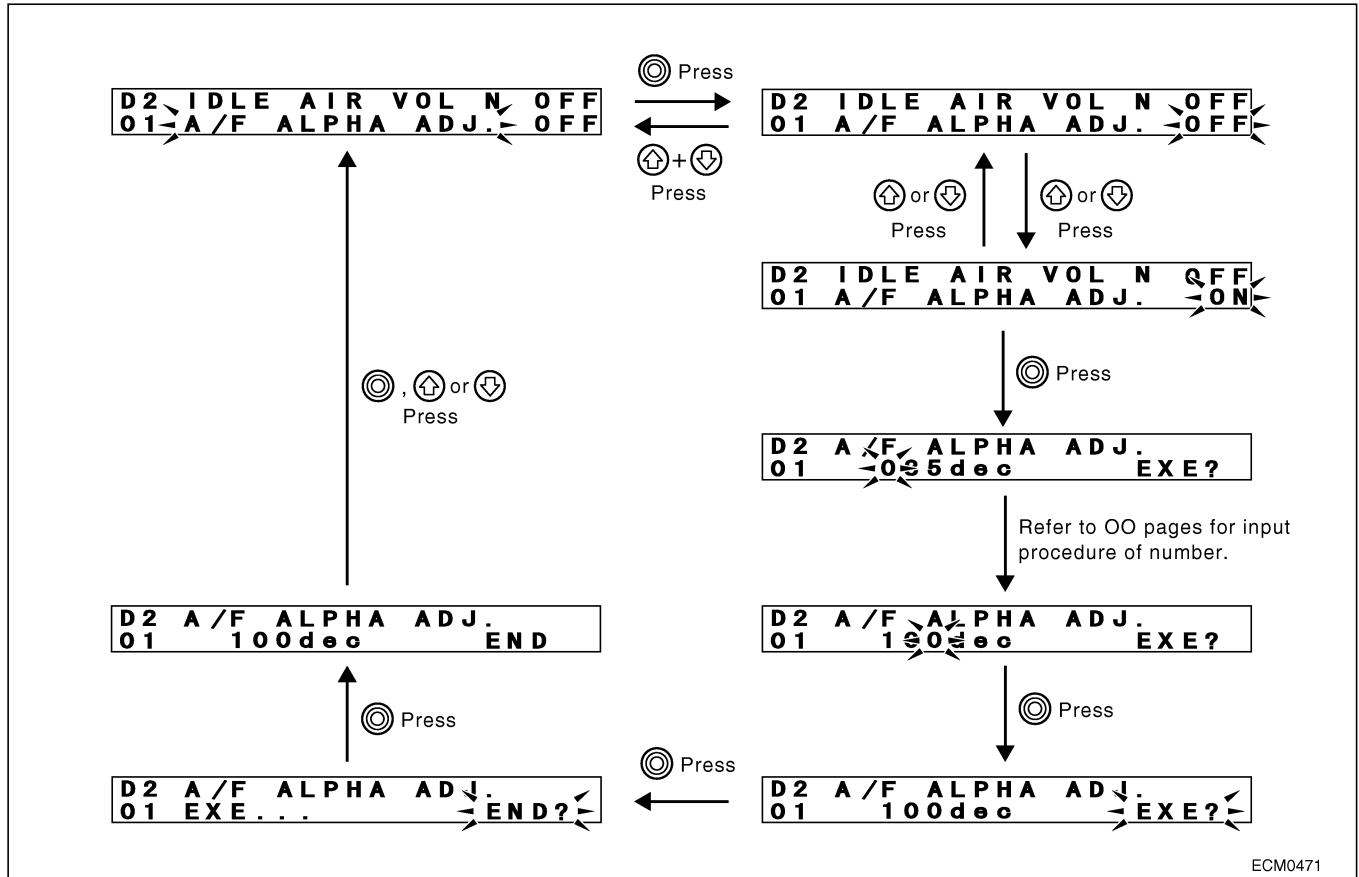

ECM0471

PRECAUTIONS FOR ECM ACTIVE TEST

Air-fuel ratio adjustment

For performing the test of air-fuel ratio adjustment, please refer to the following table.

Test item	Proper value	Adjustment range
Air-fuel ratio adjustment	100	75-125

Air-fuel ratio adjustment

First, the current adjustment value is displayed. Set the adjustment value to "100" (Proper value), and then perform the adjustment once. Check the adjustment value again. Confirm that the adjustment value is changed to "100". If the adjustment value does not change, set the adjustment value to "100" and perform the adjustment. Reference: Whether the air-fuel ratio is adjusted or not can be checked by performing the adjustment with the adjustment value between 75 and 125 since second times. (Please note that the proper test may not be performed when performing the adjustment without the adjustment range "75 - 125".)

VEHICLE CONTROL MODULE

Diagram

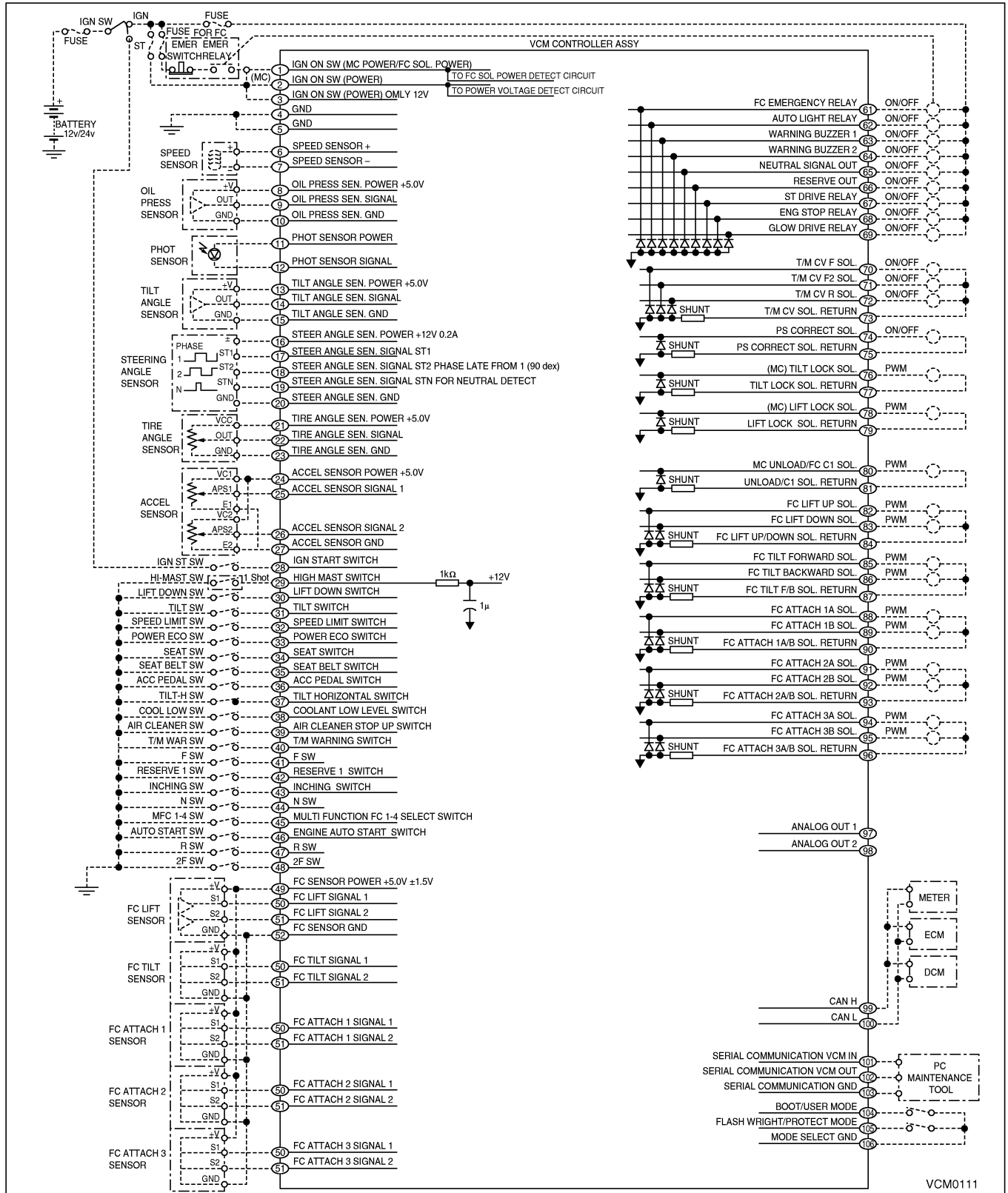

VCM0111

UNIT INSPECTION AND ADJUSTMENT

Inspection (Cont'd)

C/V tilt lock solenoid (option)

Check resistance.

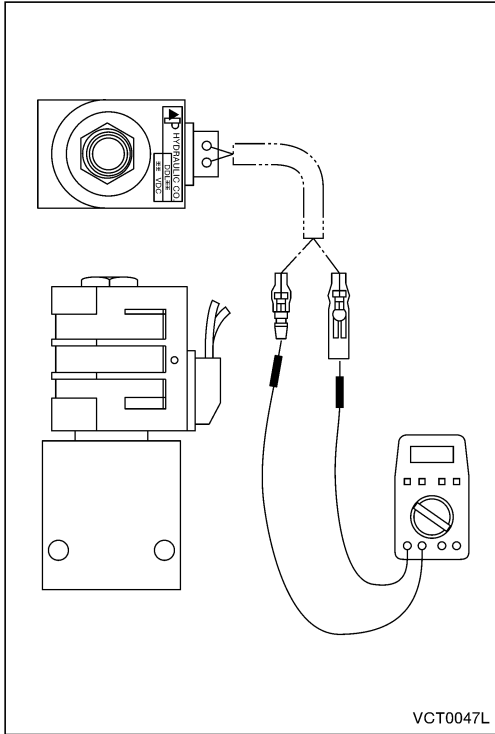

Item	Resistance
Normal	11 - 3Ω
Malfunction	0Ω or ∞

T/M forward/backward solenoid (pneumatic model)

Check resistance.

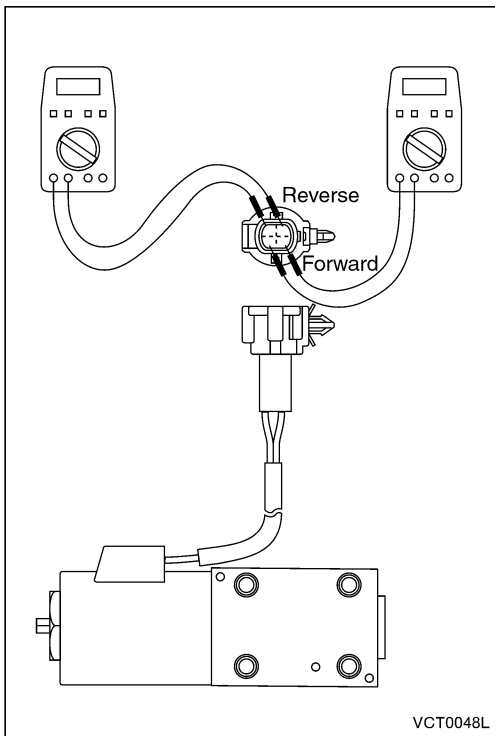

Item	Resistance
Normal	4 - 7Ω
Malfunction	0Ω or ∞

COUNTERWEIGHT, FRAME, INSTRUMENT FRAME

2. COUNTERWEIGHT, FRAME, INSTRUMENT FRAME

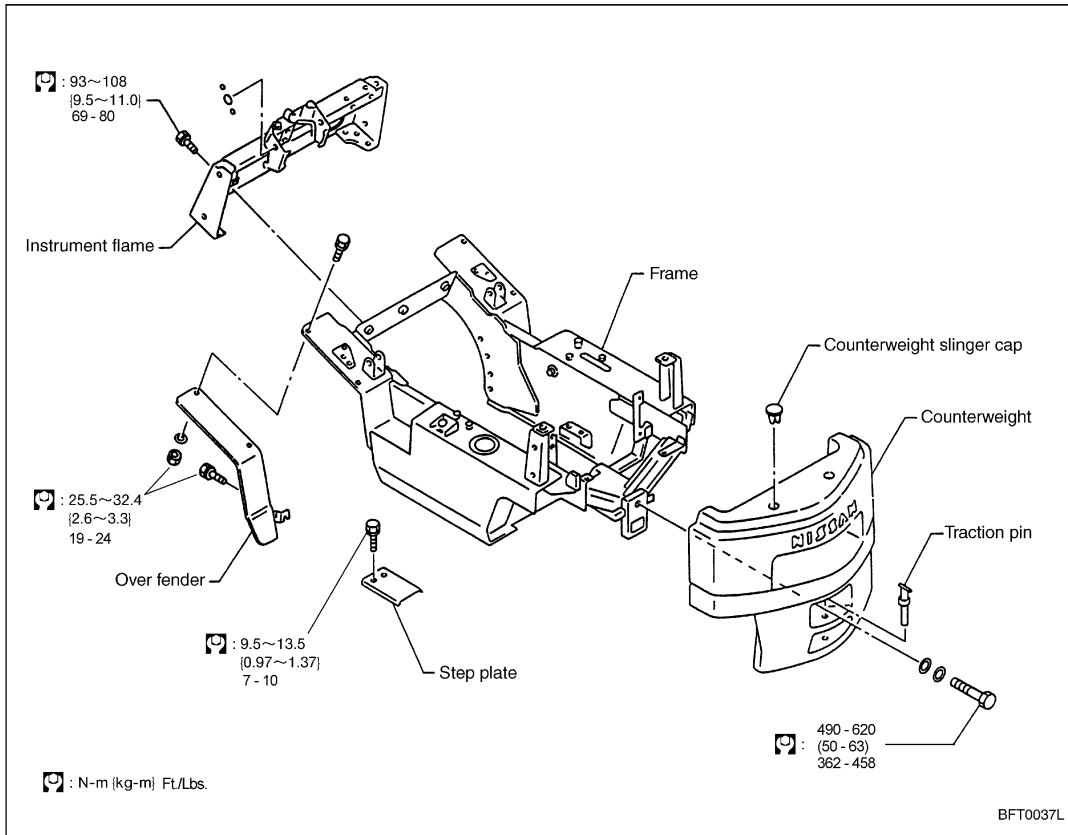

3. UNDER COVER (option)

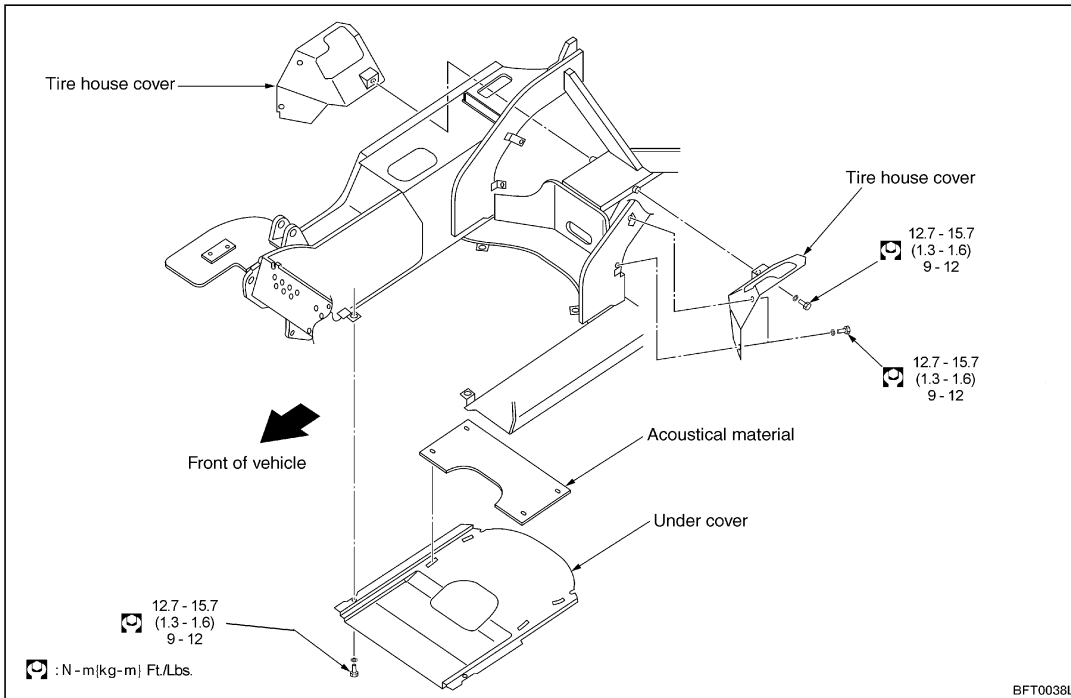

WIRE HARNESS

NOTE: This page describes the subtraction color of C1F1/C1F2 against BE-6 page. Refer to BE-6 page for the colors not described on this page.

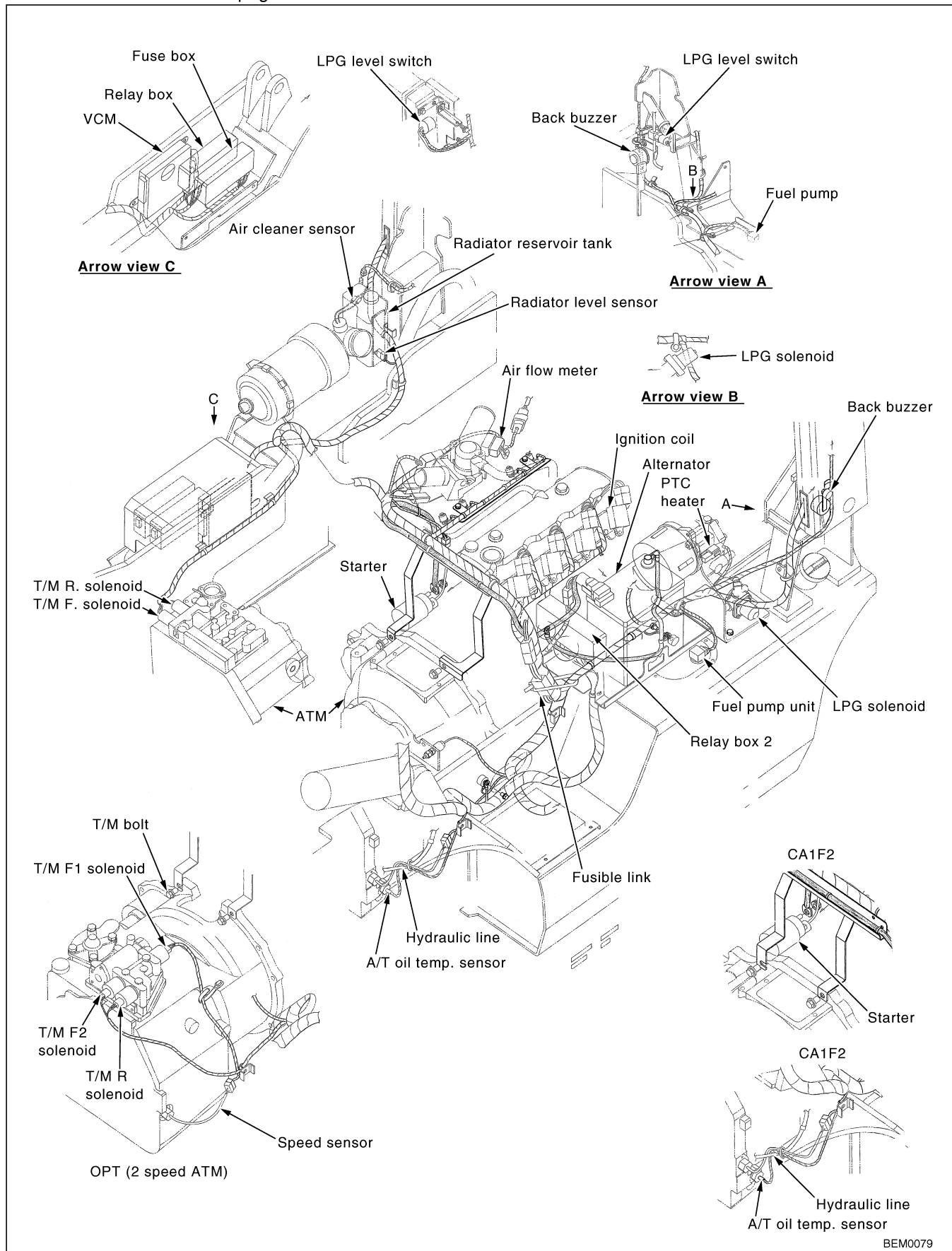

BEM0079

FUSE BOX

(2) Removal and Installation

Installation location (A1F1, C1F1)

- Remove the right step cover and the electrical component cover. Fuse box is fixed together with relay box.

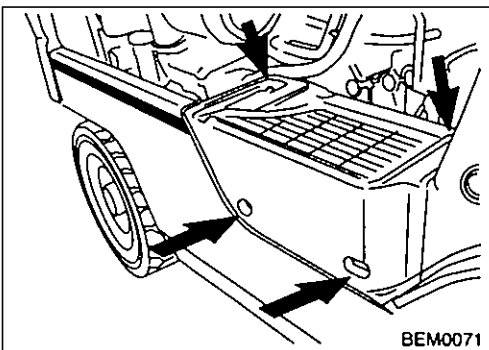
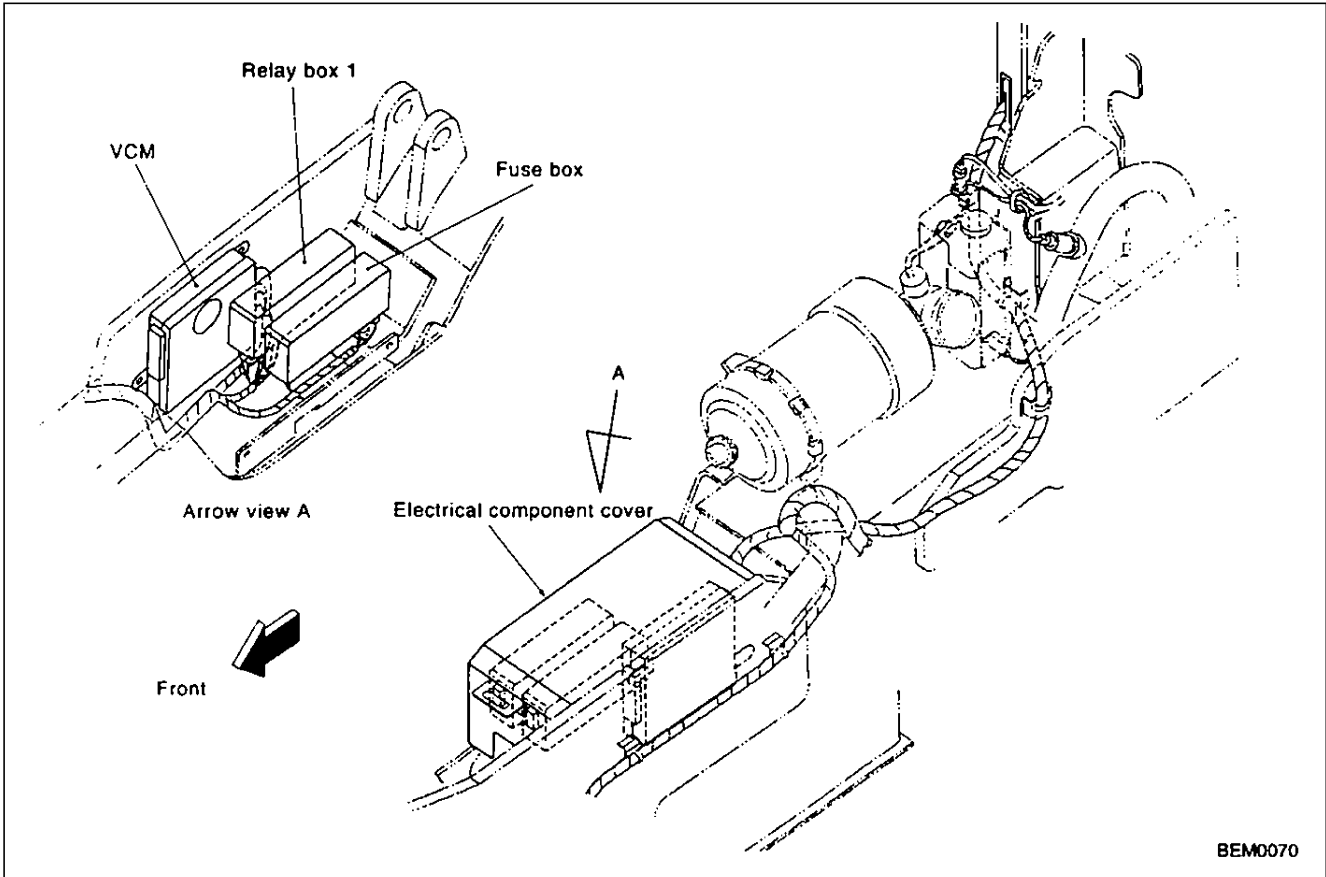

Removal

1. Open the top panel, and then remove floor panel.
2. Remove bolts (4), and then remove the step cover.

3. Remove the electrical component cover fixing bolts (4).

Tightening torque:

13 - 16 N•m (1.3 - 1.6 kg-m, 9 - 12 ft-lb)

NOTE:

- Electrical component cover cannot be removed only to remove the fixing bolts. This is because it is engaged with the tilt cylinder cover (RH).

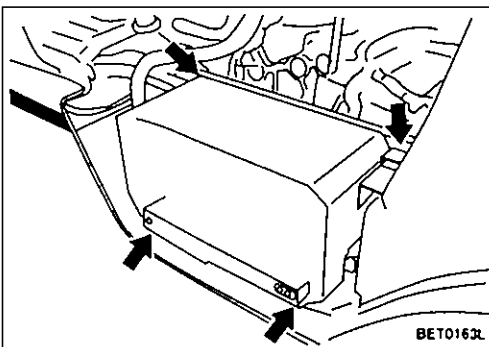

6. SWITCHES

(1) Combination Switch

DESCRIPTION

- The turn signals and F/R switches were integrated into a single unit. Also, a light switch structure was adopted.
- An auto return function was adopted for the turn signal lever.
- Three-stage light switches were adopted, with the third stage being auto light mode (optional).
- A single-stage forward/single-stage reverse system was adopted for the selector lever.

Light switch

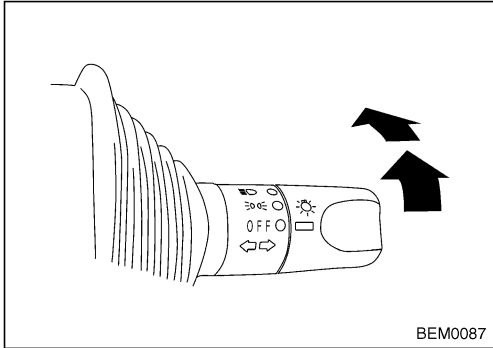

Switch position	Lamps
1st step	<ul style="list-style-type: none"> •Meter illumination lamp •Tail lamp •Clearance lamps (vehicle inspection specifications)
2nd step	<ul style="list-style-type: none"> •Meter illumination lamp •Tail lamp •Clearance lamp (vehicle inspection specifications) •Headlamp

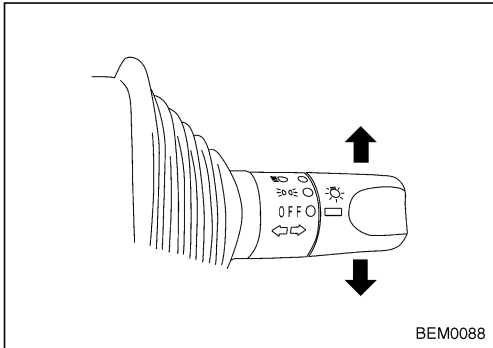

Turn signal switch

- This switch is used to indicate the forklift's direction of travel. If the light switch is moved forward or toward the driver, the direction indicator will flash on and off.
 - To turn left: Press the switch away from the driver.
 - To turn right: Pull the switch toward the driver.

NOTE:

- Selector lever (torque-converter models) is installed on left side when the other switches are on the right side (option). The operation is the same.

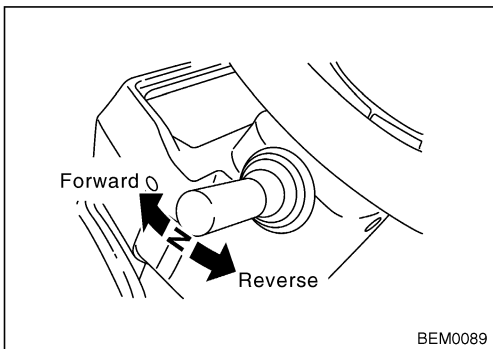

Selector lever (torque-converter models)

- Switch for changing moving direction (forwards or backwards)
 - Lever position is forward/backward when moving forward/backward direction. The middle position is neutral.

NOTE:

- On the right side (option), the operation is the same too.

(8) License Lamp

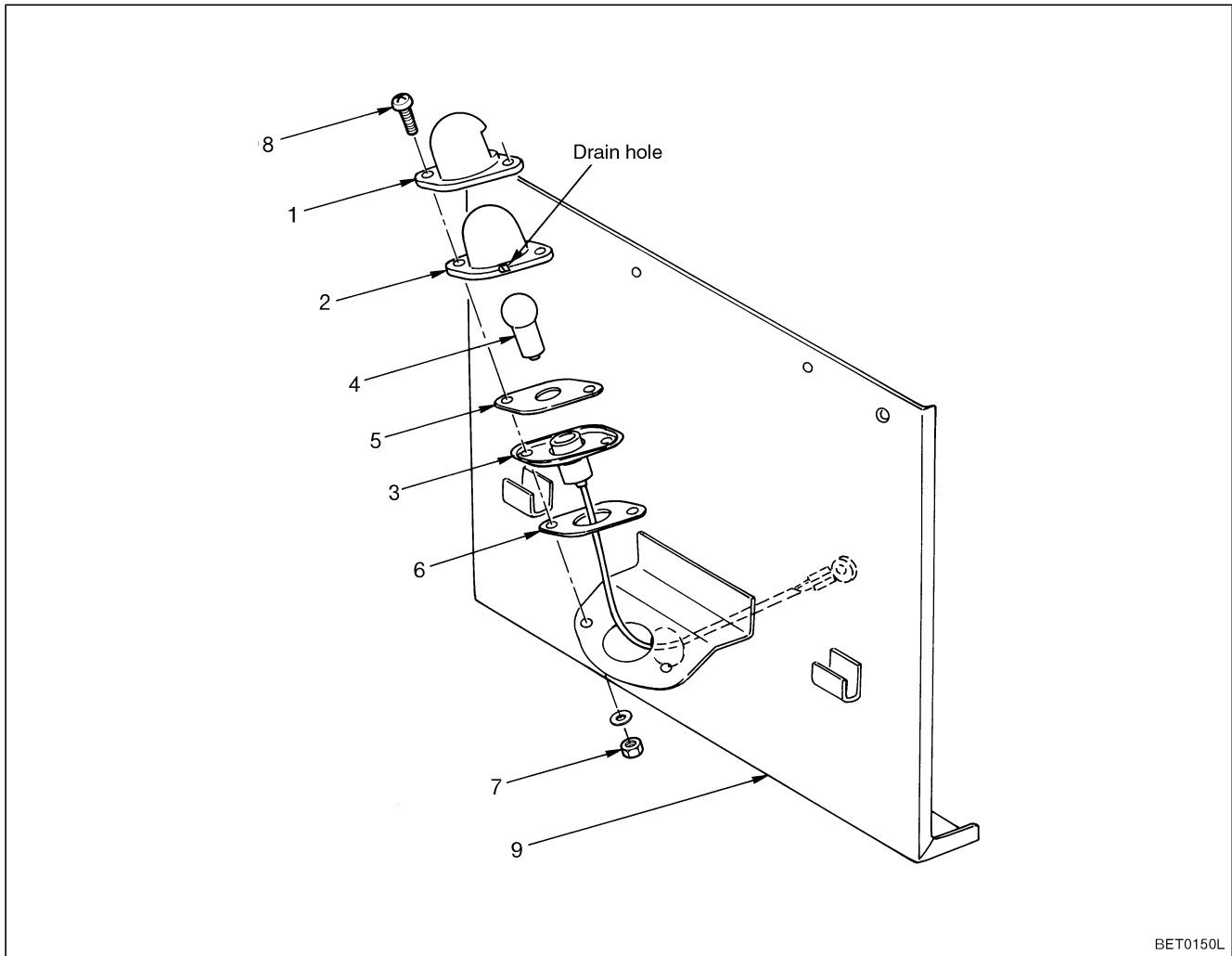

- 1. Cover
- 2. Lens
- 3. Housing

- 4. Bulb
- 5. Packing
- 6. Packing

- 7. Nut
- 8. Screw
- 9. Bracket

Removal and Installation

1. Remove license lamp securing screws and disconnect harness connector
2. When replacing bulb, remove bracket securing screw.
3. Install in the reverse order of removal.



CAUTION:

- **When installing lens, drain hole should place downward.**

NOTE:

- Installation position is upward from counter weight using LPG stand mounting hole.
- Bracket is newly designed.
- Licence plate position of compact car is the same as J models.

INTRODUCTION

This service manual has been prepared to provide necessary information concerning the maintenance and repair procedures for the NISSAN FORKLIFT 1F1 and 1F2 series.

Any changes effected in the series after publication of this service manual will be announced in a technical bulletin. It is, therefore, recommended that each relevant technical bulletin be inserted in front of each section and be used together with the service manual as a reference.

If a new model requires different service method or has undergone a major change, revised sections will be issued to replace the applicable sections. Each revised section will include the description of how to service the parts for the former specifications. The publication of a revised section will be announced in the technical bulletin.

This service manual consists of eight sections as shown in the following table, which gives the updated symbols. When a revised service manual is issued, this "INTRODUCTION" sheet should be replaced with a revised one.

Section	Symbol
GENERAL	(GI)
MAINTENANCE	(MA)
ENGINE TUNE-UP	(ET)
ENGINE MECHANICAL	(EM)
ENGINE LUBRICATION & COOLING SYSTEMS	(LC)
ENGINE FUEL	(EF)
ENGINE CONTROL SYSTEM	(EC)
ENGINE ELECTRICAL	(EE)

QD32 ENGINE.....Following EE-18

NOTE: This service manual contains information and specifications for both carbureted general overseas market (GOM) models, as well as, electronic control models (manufactured in USA.) Therefore, ensure the specifications or procedures you are looking at are for the proper fuel delivery system; electronic controlled or carbureted.

Edition: January 2007
Printing: January 2007 (1)
Publication:

Correct Operation

- Make sure that you understand the symptoms before starting trouble diagnosis.
- Check correct installation status prior to removal or disassembly. Make sure that they do not interfere with the function of the parts they are applied to if matching marks are required.
- Once they are removed, always replace parts indicated as "do not reuse" with new ones. This includes: oil seals, gaskets, packings, O-rings, lock washers, cotter pins, and self-locking nuts.
- Replace inner and outer races of tapered or needle roller bearings as a set.
- Arrange disassembled parts in order and prevent them from being mixed-up.
- Clean or flush disassembled parts prior to inspection or assembly.
- Use Genuine NISSAN parts for replacement.
- Use authorized grease and sealer.
- Release the pressure before disconnecting pressurized piping or hoses.
- Be sure to check for leakage after repairing fuel, oil, coolant, exhaust, or vacuum systems.

Precautions for Radio Equipment Installation

Check the following when installing a commercial/ham radio or mobile phone. If mounting position is not chosen carefully, the unit may interfere with the electronic control system.

- Separate the antenna as far from the Engine Control System as possible.
- Route an antenna feeder line at least 20 cm (7.87 in) apart from the control unit harness.
- Adjust antenna and feeder line to eliminate radio wave interference.

MAIN SPECIFICATIONS

MAIN SPECIFICATIONS OF IGNITION SYSTEM

Engine type		K21				K25						
Engine control system		Electronic controls			Carburetor type		Electronic controls			Carburetor type		
Fuel specification		Gasoline	LPG	Combined	Gasoline	Combined	Gasoline	LPG	Combined	Gasoline	Combined	
Ignition device		Non-contact type (Engine Control System)			Non-contact type (Full transistor)		Non-contact type (Engine Control System)			Non-contact type (Full transistor)		
Ignition coil (with power transistor)		Hanshin Electric type		AIC-4002G			AIC-4002G					
Crankshaft position sensor	Crankshaft position sensor (POS)	HJ type		Hall IC type Hitachi Unisia Automotive			Hall IC type Hitachi Unisia Automotive					
	Camshaft position sensor (PHASE)	HJ type		Hall IC type Hitachi Unisia Automotive			Hall IC type Hitachi Unisia Automotive					
Distributor (with ignition coil)		Mitsubishi Electric type			T6T87778			T6T87779				
Spark plug		NGK type		FR2A-D			FR2A-D					
		Gap mm (in)		0.9 (0.035)			0.9 (0.035)					

FUEL SYSTEM AND ENGINE SPEED CONTROL SYSTEM

Engine type		K21				K25					
Engine control system		Electronic controls			Carburetor type		Electronic controls			Carburetor type	
Fuel specification		Gasoline	LPG	Combined	Gasoline	Combined	Gasoline	LPG	Combined	Gasoline	Combined
Fuel device standard type		Electronic controlled fuel injection device (Engine Control System)					Electronic controlled fuel injection device (Engine Control System)				
Fuel device		Gasoline injector	LPG injector	Gasoline & LPG	Carburetor	Carburetor + LPG adapter	Gasoline injector	LPG injector	Gasoline & LPG	Carburetor	Carburetor + LPG adapter
Air-fuel ratio control device		Air-fuel ratio feedback control					Air-fuel ratio feedback control				
Starting auxiliary device		Electric throttle control actuator			Hot water type auto choke		Electric throttle control actuator			Hot water type auto choke	
Idle load control type		Electric throttle control actuator			FICD		Electric throttle control actuator			FICD	
Engine speed control type		Electric throttle control actuator			Pneumatic governor		Electric throttle control actuator			Pneumatic governor	

EXHAUST GAS CLEANUP DEVICE LIST

Engine type		K21				K25					
Engine control system		Electronic controls			Carburetor type		Electronic controls			Carburetor type	
Fuel specification		Gasoline	LPG	Combined	Gasoline	Combined	Gasoline	LPG	Combined	Gasoline	Combined
Catalytic device (Reducing HC, CO, Nox)	Type	Three-way catalyst (Monolith)					Three-way catalyst (Monolith)				
	Location	In counter weight with muffler separated					In counter weight with muffler separated				
	Capacity	0.45L (3/4 Imp pt)					0.45L (3/4 Imp pt)				
PCV gas recirculation device		Closed type			Closed type		Closed type			Closed type	

TROUBLE DIAGNOSIS

Engine Adjust. (Cont'd)

Condition	Possible causes	Action
Incident in fuel system Refer to EF section for the LPG model.	• Malfunction of carburetor choke system	Adjust.
	• Plugged fuel piping	Clean
	• Plugged or contaminated fuel filter	Replace.
	• Fuel pump malfunction	Repair or replace
	• Plugged carburetor jet or needle valve	Disassemble and clean.
	• Poor throttle valve opening	Adjust.
	• Fuel pump malfunction	Adjust.
Incident in intake system	• Plugged air cleaner	Replace element
	• Air leakage from electronic throttle insulator	Replace insulator.
	• Air leakage from manifold gasket or carburetor insulator	Replace gasket or insulator.
Engine over temperature (Overheat)	• Insufficient amount of coolant	Fill coolant.
	• Loose fan belt.	Adjust belt tension.
	• Worn or loose fan belt	Replace.
	• Malfunctioning thermostat	Replace.
	• Water pump malfunction	Replace.
	• Plugged or leaking radiator	Wash, repair, or replace.
	• Radiator cap damage	Replace.
	• Air in cooling system piping	Retighten cooling system piping, bleed system.
	• Improper engine oil grade	Replace with appropriate grade of engine oil.
	• Inappropriate ignition timing	Adjust.
	• Carburetor malfunction (too lean air-fuel mixture)	Overhaul carburetor.
	• Malfunctioning thermostat	Replace.
Other	• Inappropriate octane rating of fuel	Replace with specified octane rating of fuel.
	• Insufficient tire air pressure	Charge to specified air pressure.
	• Brake dragging	Adjust.
	• Clutch slippage	Adjust.
Engine noise		
Knocking	• Engine overload	Operate with light load
	• Knocking due to carbon deposits	Remove cylinder head and eliminate carbon deposits.
	• Knocking due to inappropriate ignition timing	Adjust ignition timing.
	• Knocking due to inappropriate octane rating of fuel	Use specified octane rating of fuel.
	• Too advance ignition (Inappropriate spark plug selection)	Use specified type of spark plug.
Mechanical slapping		
Crankshaft bearing slapping	• Strong and heavy noise from engine during acceleration	A possible cause is in damage/wear of bearing or uneven wear of crankshaft.
	• To identify the noise generation point, attempt to cause misfires at each cylinder.	Need to replace bearing and adjust or replace crankshaft.
	• If misfires at a particular cylinder stop the noise, that cylinder is the noise source.	
Connecting rod bearing slapping	• This noise is also generated during engine acceleration but at a little more rapid pitch than crank slapping.	Take the same action as that for crankshaft bearing.
	• To identify the noise generation point, attempt to cause misfires at each cylinder.	
	• If misfires at a particular cylinder almost stop the noises, that cylinder is the noise source.	

ENGINE MAINTENANCE

Tightening Torque

Upper: Lubricated (Antirust oil is applied to abrasive faces of threads and seating faces)

Lower: No lubrication (Threads and seating faces are completely degreased)

	Thread size		Unit	4T (Bolt)	7T (Bolt)	9T (Bolt)
	Diameter	Pitch				
Hexagon head bolt and nut	M6	1	N-m	3.8 - 4.4	6.4 - 7.5	9.2 - 10.8
			kg-m	0.39 - 0.45	0.65 - 0.76	0.94 - 1.1
			ft-lb, in-lb*	34 - 39*	56 - 66*	82 - 95*
			N-m	5.0 - 6.5	8.4 - 10.8	11.8 - 15.7
			kg-m	0.51 - 0.66	0.86 - 1.1	1.2 - 1.6
			ft-lb, in-lb*	44 - 57*	75 - 95*	9 - 12
	M8	1.25	N-m	9.3 - 10.8	15.7 - 17.7	22.6 - 25.5
			kg-m	0.95 - 1.1	1.6 - 1.8	2.3 - 2.6
			ft-lb, in-lb*	82 - 95*	12 - 13	17 - 19
			N-m	12.7 - 15.7	20.6 - 26.5	29.4 - 37.3
			kg-m	1.3 - 1.6	2.1 - 2.7	3.0 - 3.8
			ft-lb, in-lb*	9 - 12	15 - 20	22 - 19
	M10	1.25	N-m	19.6 - 22.6	32.4 - 38.2	47.1 - 53.9
			kg-m	2.0 - 2.3	3.3 - 3.9	4.8 - 5.5
			ft-lb, in-lb*	14 - 17	24 - 28	35 - 40
			N-m	25.5 - 33.3	43.1 - 54.9	61.8 - 78.5
			kg-m	2.6 - 3.4	4.4 - 5.6	6.3 - 8.0
			ft-lb, in-lb*	19 - 25	32 - 41	46 - 58
1.5		N-m	18.6 - 21.6	30.4 - 36.3	44.1 - 52	
		kg-m	1.9 - 2.2	3.1 - 3.7	4.5 - 5.3	
		ft-lb, in-lb*	14 - 16	22 - 27	33 - 38	
		N-m	24.5 - 31.4	41.2 - 52	58.8 - 74.5	
Flanged bolt	M6	1	N-m	4.9 - 5.69	8.14 - 9.51	11.8 - 13.7
			kg-m	0.5 - 0.58	0.83 - 0.97	1.2 - 1.4
			ft-lb, in-lb*	43 - 50*	72 - 84*	9 - 10
			N-m	5.98 - 7.65	9.81 - 12.7	14.7 - 18.6
			kg-m	0.61 - 0.78	1.0 - 1.3	1.5 - 1.9
			ft-lb, in-lb*	53 - 68*	87 - 113*	11 - 14
	M8	1.25	N-m	11.8 - 13.7	19.6 - 23.5	28.4 - 33.3
			kg-m	1.2 - 1.4	2.0 - 2.4	2.9 - 3.4
			ft-lb, in-lb*	9 - 10	14 - 17	21 - 22
			N-m	14.7 - 18.6	24.5 - 31.4	35.3 - 45.1
			kg-m	1.5 - 1.9	2.5 - 3.2	3.6 - 4.6
			ft-lb, in-lb*	11 - 14	18 - 23	26 - 33
	M10	1.25	N-m	24.5 - 29.4	41.2 - 48.1	59.8 - 69.6
			kg-m	2.5 - 3.0	4.2 - 4.9	6.1 - 7.1
			ft-lb, in-lb*	18 - 22	30 - 35	44 - 51
			N-m	30.4 - 39.2	51.0 - 64.7	73.6 - 93.2
			kg-m	3.1 - 4.0	5.2 - 6.6	7.5 - 9.5
			ft-lb, in-lb*	22 - 29	38 - 48	54 - 69
1.5		N-m	23.5 - 27.5	39.2 - 46.1	56.9 - 65.7	
		kg-m	2.4 - 2.8	4.0 - 4.7	5.8 - 6.7	
		ft-lb, in-lb*	17 - 20	29 - 34	42 - 48	
		N-m	29.4 - 37.3	49.0 - 61.8	69.6 - 89.2	
			kg-m	3.0 - 3.8	5.0 - 6.3	7.1 - 9.1
			ft-lb, in-lb*	22 - 27	36 - 46	51 - 48

(*) INDICATES INCHES-POUNDS



CAUTION:

- Except special nuts and bolts.
- The bolts applicable to this table have one of the following marks embossed on their heads.

4T.....4

7T.....7

9T.....9

SPECIFICATIONS

Items	Engine type	K21	K25
Valve clearance (Hot) mm (in)	Intake	0.38 (0.015)	
	Exhaust		
Fan belt deflection	mm (in)	11 - 13 (0.43 - 0.51)	
Belt push force	N (kg, lb)	98 (10,22)	
Engine oil amount	L (US qt, Imp qt)		
(including oil filter)		3.7 (3-7/8,3 - 1/4)	
(not including oil filter)		3.4 (3-3/4,3 - 1/8)	
Compression pressure	kPa (bar, psi/rpm)		
Standard		1.23 (12.5/178/250)	1.27 (13.0/185/250)
Minimum value	kPa (bar, psi/rpm)	981 (9.8, 10, 142/250)	
Spark plug type		FR2A-D	
Plug gap	mm (in)	0.9 (0.035)	
Distributor gap	mm (in)	(Carburetor model only) 0.35 - 0.45 (0.0138 - 0.0177)	
High-tension cable resistance	Ω	(Same as above) 30,000 or less	
Ignition timing/idle speed	BTDC deg./rpm	0°/700±50	
Maximum engine speed without load	rpm (instantaneous)	3,600	
Maximum engine speed with load	rpm	3,000	
CO density (5)		0.1 or less	
HC density (ppm)		50 or less	

Engine Body Related (Cont'd)

COMPRESSION PRESSURE INSPECTION

1. Warm up the engine sufficiently and then stop it.
Release the fuel pressure. (Electronic controlled specifications)
2. Remove the spark plug.
3. Apply a compression gauge correctly to the cylinder plug hole to be measured.
4. Depress the throttle pedal to the fully-open position.
5. Crank the engine and read the gauge.
 - Keep the engine speed at approximately 250 rpm.
 - Finish the pressure measurement in as short a time as possible.

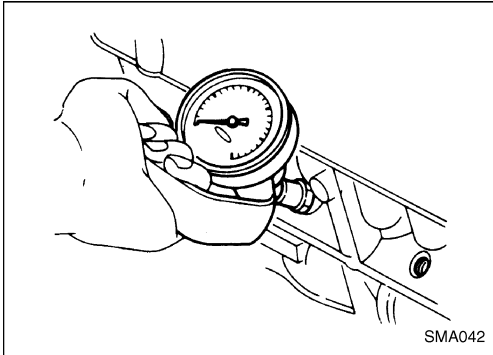

Standard compression pressure

K21	1.23 MPa (12.26 bar, 12.5 kg/cm ² , 178 psi)
K25	1.27 MPa (12.7 bar, 13.0 kg/cm ² , 185 psi)

6. The compression pressure differences between cylinders must not exceed 98 kPa (1.0 bar, 1 kg/cm², 14 psi) /250 rpm. If any cylinder shows an extremely low compression pressure, put a small amount of oil into the cylinder through the spark plug hole and remeasure the pressure.
 - If the pressure rises after filling oil, the piston ring is worn or damaged.
 - If the pressure remains unchanged even after filling oil, the valve is stuck or inappropriately seated.
 - If low compression pressure is observed in two adjacent cylinders and the pressure is not restored even after filling oil, the head gasket is leaking. In this case, oil and water may enter in the combustion chamber.
 - If the engine RPM is not in the specified range: Measure the battery specific gravity.

PRECAUTIONS



CAUTION:

For Draining Engine Coolant

- Drain coolant only after the engine has cooled down.



CAUTION:

For Disconnecting Fuel Piping

- Operation should be done in a place free from fire.
- Release fuel pressure before operation. (Electronic controlled specifications): Refer to "Release of Fuel Pressure" in EC section.
- After disconnecting, plug the pipe to prevent fuel from draining.

Precautions for Removing and Disassembling

- Use correct SSTs in the specified position. Always pay attention to safety.
- Be careful not to lose surface accuracy of mating or sliding surfaces.
- To prevent foreign material from entering the engine, close openings with appropriate tape as necessary.
- Arrange disassembled parts in their normal positions in order to simplify locating the cause of damage or excessive wear and to ensure correct reassembly.
- As a rule, nuts and bolts must be tightened in a diagonal manner starting from an outer one. If a particular tightening sequence is provided separately, follow the sequence.

Precautions for Inspection, Correction, and Replacement

- Following the inspection procedure, inspect the parts adequately and repair or replace as necessary. Perform the same inspections even for new parts and replace them if necessary.

Precautions for Assembly and Installation

- Always use a torque wrench when tightening nuts and bolts.
- Unless otherwise specified, tighten bolts and nuts from inside to outside in a crisscross pattern. Tighten them gradually and evenly in 2 to 3 steps.
- Always replace gasket, packing, oil seals, and O-rings with new ones.
- For each part, perform adequate cleaning/washing and drying with a dryer. In particular, ensure that the oil and coolant passages are free from plugging and clogging.
- Remove any dirt and lint on sliding and mating surfaces. Before assembly, apply ample amount of engine oil to sliding surfaces.
- If coolant was drained, bleed air from the system.
- After assembly, start engine and increase the engine speed, then check coolant, fuel, oil, grease, and exhaust gas for leakage.

TIGHTENING TORQUE

TAPER SCREW TIGHTENING TORQUE

Allowable materials for tightening Normal size	Unit	Aluminum		Cast iron	
		Standard	Max. value	Standard	Max. value
R1/8	N•m	7.8	11.8	15.7	21.6
	kg-m	0.796	1.2	1.6	2.2
	ft-lb, in-lb*	69*	9	12	16
R1/4	N•m	19.6	29.4	34.3	44.1
	kg-m	2.0	3.0	3.5	4.5
	ft-lb	14	22	25	33
R3/8	N•m	39.2	54.9	53.9	73.5
	kg-m	4.0	5.6	5.5	7.5
	ft-lb	29	41	40	54

Engine Part Tightening Torque

TIGHTENING TORQUE AT VARIOUS POINTS OF ENGINE

Tightening point	Unit	Standard	Max. value
Cylinder head (lubricated)		Separately given	
Main bearing cap (lubricated)		Separately given	
Crankshaft pulley bolt	N•m	220.5	240.1
	kg-m	22.5	24.5
	ft-lb	163	177
Flywheel bolt (lubricated)	N•m	132	142
	kg-m	13.47	14.49
	ft-lb	97	105
Connecting rod nut (lubricated)	N•m	31.4	37.3
	kg-m	3.2	3.81
	ft-lb	23	28
Rear plate bolt	N•m	44.1	58.8
	kg-m	4.5	6.0
	ft-lb	33	43
Camshaft sprocket bolt	N•m	39.2	49
	kg-m	4.0	5.0
	ft-lb	29	36
Oil filter stud	N•m	29.4	39.2
	kg-m	3.0	4.0
	ft-lb	22	29
Oil filter element	N•m	14.7	20.6
	kg-m	1.5	2.1
	ft-lb	11	15
Spark plug	N•m	19.6	29.4
	kg-m	2.0	3.0
	ft-lb	14	22
Engine slinger bolt	N•m	22.6	25.5
	kg-m	2.31	2.6
	ft-lb	17	22
Rocker cover nut	N•m	14.7	16.7
	kg-m	1.5	1.7
	ft-lb	11	13
Water temperature gauge	N•m	15.7	19.6
	kg-m	1.6	2.0
	ft-lb	12	14
Oil pressure switch	N•m	15.7	21.6
	kg-m	1.6	2.2
	ft-lb	12	16
Exhaust manifold nut	N•m	41.2	48.1
	kg-m	4.2	4.91
	ft-lb	30	36
Straight screw plug (For head top face)	N•m	44.1	58.9
	kg-m	4.5	5.5
	ft-lb	33	40
Oil pan drain plug	N•m	29.4	39.2
	kg-m	3.0	4.0
	ft-lb	22	29
Mass air flow sensor mounting screw	N•m	1.27	1.67
	kg-m	0.13	0.17
	in-lb	11	15
Fuel tube flare nut	N•m	16.0	23.0
	kg-m	1.63	2.35
	ft-lb	12	17
Crankshaft position sensor plug bolt	N•m	6.37	7.45
	kg-m	0.65	0.76
	in-lb	56	66
Thermo-housing relief plug	N•m	6.37	7.45
	kg-m	0.65	0.76
	in-lb	56	66

(*) INDICATES INCHES-POUNDS

Engine Disassembly (Cont'd)

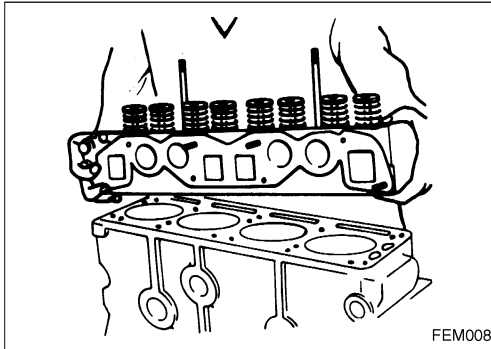

8. Remove oil pan.
Remove any sealant.

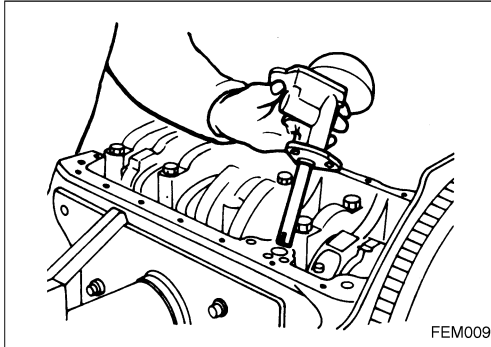

9. Remove oil pump with strainer.

10. Disassembly of PTO device

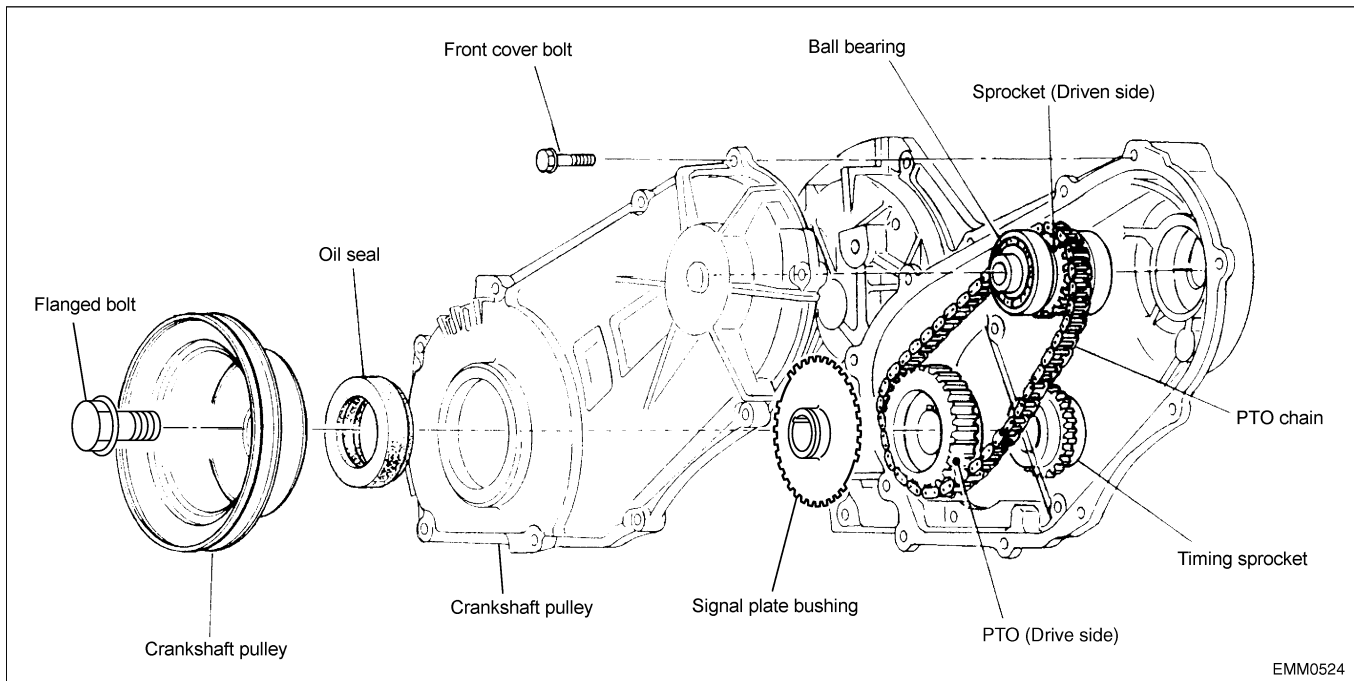

- Remove crankshaft pulley bolt.
- Remove crankshaft pulley.
- Remove the sprocket bushing.

Inspection and Correction (Cont'd)

MEASURING CONNECTING ROD THRUST CLEARANCE

- Measure the thrust clearance using a feeler gauge.
- Measure the connecting rod side clearance. If the clearance exceeds the limit, replace the connecting rod.
Standard clearance: 0.2 - 0.3 mm (0.008 - 0.012 in)
Max. clearance: 0.4 mm (0.016 in)

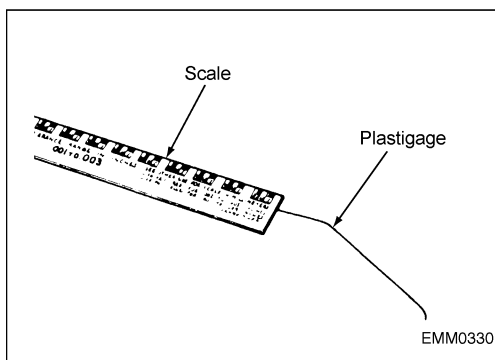
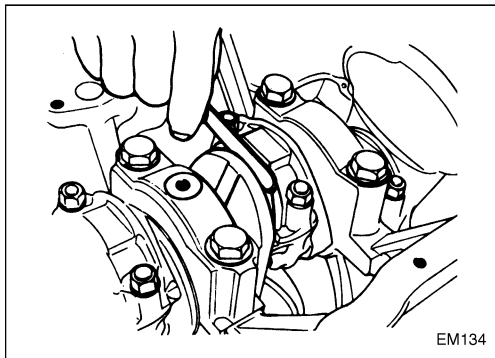

12. Connecting rod and bushings

- Check the bushings for bend, melting, or tearing and replace them if damaged.
- Measure the oil clearance using a plastigage.

MEASURING OIL CLEARANCE

- The following paragraphs describe how to use a plastigage.
 - Remove any oil and dust from the bearing inner/outer faces and journal faces. Cut off the plastigage to a length slightly shorter than the bearing width. Place the cut plastigage on the journal face so as not to cover any oil holes.
 - Assemble the bearing cap and tighten it to the specified torque.



CAUTION:

- **Do not turn the crankshaft while the plastigage is in the bearing.**
 - Remove the cap and read the plastigage width using the scale printed on the bag.
 - If the clearance exceeds the limit, use an undersize bearing. At that time, grind the journal or pin.

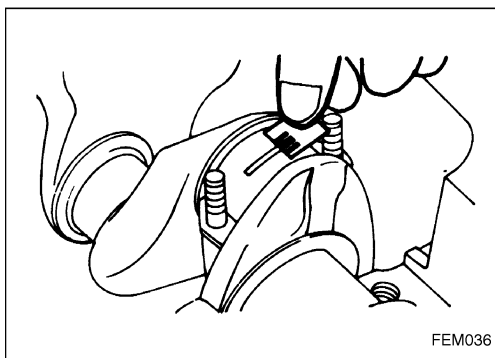

Standard Unit: mm (in)

Items	Oil clearance Standard	Oil clearance Limit	Cap tightening torque
Main bearing	0.02 - 0.073 (0.0008 - 0.0029)	0.1 (0.004)	Lubricated 83.4 - 93.2N•m (8.51 - 9.51kg-m, 62 - 69 ft-lb)
Connecting rod bearing	0.032 - 0.066 (0.0013 - 0.0026)	0.1 (0.004)	Lubricated 31.4 - 37.3N•m (3.2 - 3.81 kg-m, 23 - 28 ft-lb)

- If the oil clearance exceeds the limit, grind the journal or pin with a surface grinder and use an undersize bearing.

Engine Assembly (Cont'd)

8. Assembly of rear oil seal retainer

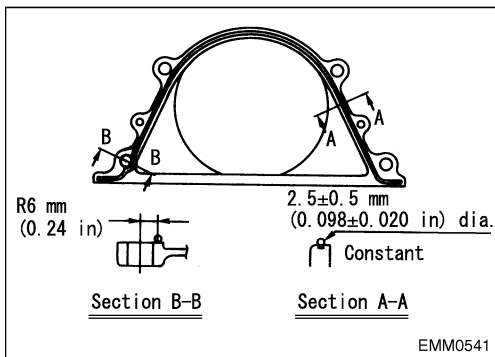
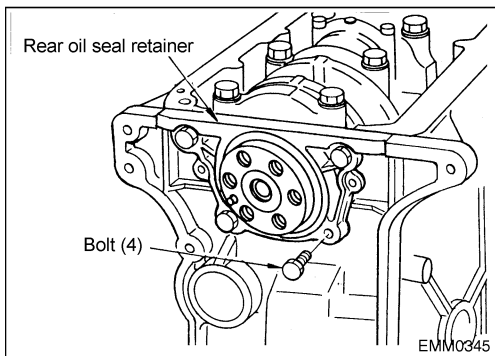
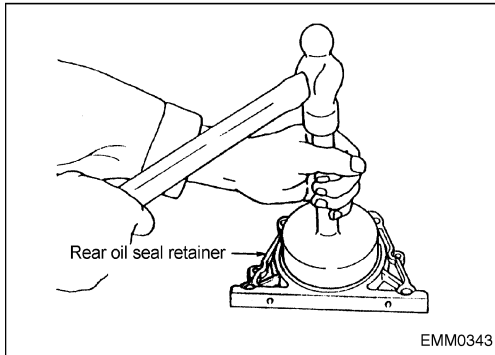

- Assemble the oil seal to the rear oil seal retainer. To drive in the oil seal, use the special service tool (KV10105500).

- Install rear oil seal retainer to cylinder block.
Rear oil seal retainer retaining bolt:
 - 21 - 36 N•m (2.1 - 3.7 kg-m, 15 - 27 ft-lb)
 - 20.6 - 26.5 N•m (2.1 - 2.7 kg-m, 15 - 20 ft-lb)

CAUTION:

- Before installing the rear oil seal retainer, apply liquid packing to the retainer as shown in the figure.
- Once attaching the retainer and tightening the bolts, do not make additional tightening or remove the retainer (and retighten).
- For the mounting face, apply a continuous bead of sealant along the groove. For the bolt holes, apply sealant so that it does not run off the inner edges.
- Make sure to finish the assembly within 5 minutes after sealant application.
- After the assembly, leave the assembled parts as is for 30 minutes or more.

PRECAUTIONS BEFORE APPLICATION:

- The mounting faces (both sides) shall be free from moisture, oil, grease, waste, dust and other foreign objects.
- Make sure to remove any sealant from the flange/mounting faces and threads when reassembling the part that has once been attached and disassembled.

9. Assembly of piston

- Assemble the bearing to the connecting rod.
- To each cylinder, assemble the corresponding connecting rod and piston subassembly according to the cylinder number.
- When assembling, turn the front mark of the piston toward the front.
- Set the crankshaft pin positions to TDC or BDC.

LUBRICATION SYSTEM

Specifications

MAIN SPECIFICATIONS

Lubrication method	Pressured supply
Oil pump	Spur gear type
Oil filter	Total flow, cartridge type

Adjustment Value

OIL PUMP

Unit: mm (in)

Clearance between pump gear and main body	0.4 (0.016) or less
Backlash of pump gear	0.5 (0.020) or less
Pump gear clearance in vertical direction	0.3 (0.012) or less

Oil Pressure

OIL PRESSURE

Unit: kPa (bar, kg/cm², psi)

Discharge pressure	At Idle	Oil temperature 80°C (176°F) 98 (0.98, 1.0, 14)
	At 2,000 rpm	275 - 314 (2.75 - 3.14, 2.8 - 3.2, 40 - 46)

Tightening Torque

	N·m	kg·m	ft-lb, in-lb*
Oil pump bolt	15.7 - 17.7	1.6 - 1.81	11.6 - 13.1
Oil pump cover bolt	6.37 - 7.45	0.65 - 0.76	56 - 66*
Oil pan bolt	6.37 - 7.45	0.65 - 0.76	56 - 66*
Oil pan drain plug	29.4 - 39.2	3.0 - 4.0	22 - 29

EMISSION CONTROL SYSTEM

Engine type		K21, K25
Standard type of fuel device	Gasoline	Electronic controlled fuel injection device (Multi-point injection)
	LPG	Electronic controlled fuel injection device (Single point injection)
Air-fuel ratio control type		Air-fuel ratio feedback control
Starting auxiliary device		Electronic controlled fuel injection
Ignition device		Ignition coil electronic controlled distributor integrated with power transistor for each cylinder
Catalytic device		Three-way catalyst (Monolith)
Braking device		With fuel cut device
PCV gas recirculation device		Closed type

Removal and Installation of Gasoline Fuel Injector (Electronic Controlled Gasoline and Combined Use) (Cont'd)

INSTALLATION OF FUEL INJECTOR

Install fuel injector to fuel tube as shown in the figure.

Precautions for installation of fuel injector

1. Make sure that there is no contamination and damage in O-ring contact area caused by dirt. Do not clean O-ring with solvent.
2. Do not reuse removed O-ring.
3. Handle O-ring with bare hands.
4. Apply engine oil into O-ring and holder for assembly. (Do not apply engine oil into fuel passages of fuel injector.)
5. Do not use damaged O-ring.
6. Do not apply excessive force to damage O-ring.
7. Press clips into fuel injector when assembling. Securely fit clips to fuel injector locating grooves (a) and (b). (Do not reuse clips.)
8. Always replace O-ring when clips contact with O-ring.
9. Assemble fuel injector to fuel tube after installing clips to fuel injector.
10. Fuel injector is pressed by a force of 196 N (20 kg, 44 lb) or less. [Stop operation if a force of 147 N (15 kg, 33 lb) or more is necessary.]
11. Insert fuel injector to fuel tube while aligning fuel tube stopper (c) with clip cutout (d) before installing. Securely fit (c) to (d) and holder rib (e) to clip hole (f) after inserting.
12. Make sure that fuel injector is securely installed without rotation and disconnection after installing to fuel tube.

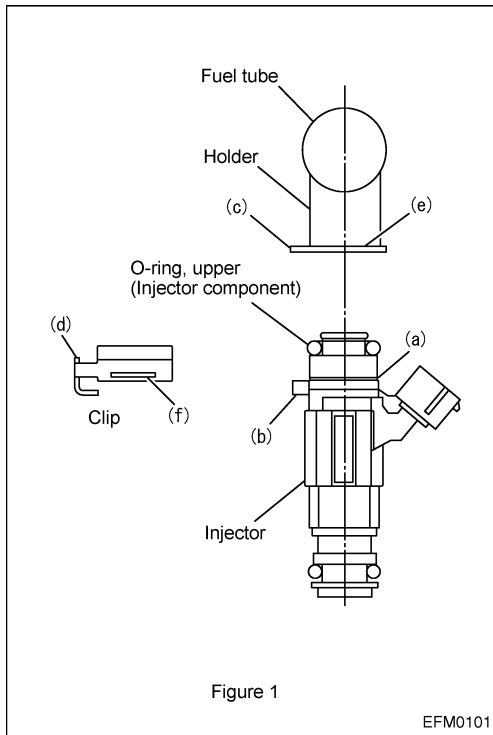

Tar drain, Removal, Installation, Disassembly and Inspection of Vaporizer (Cont'd)

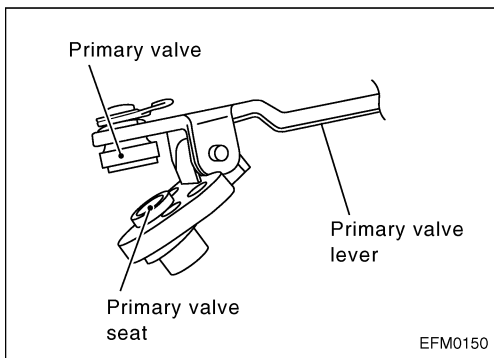
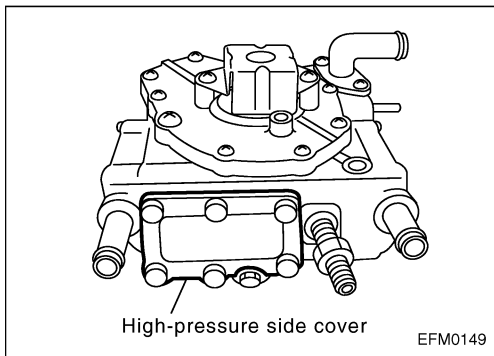
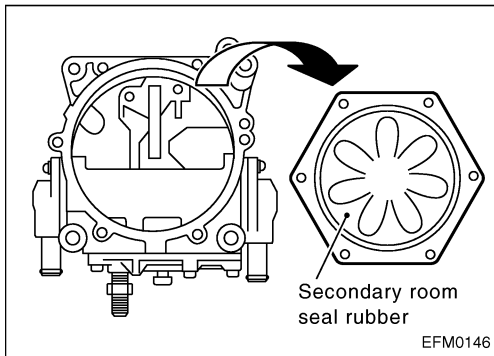
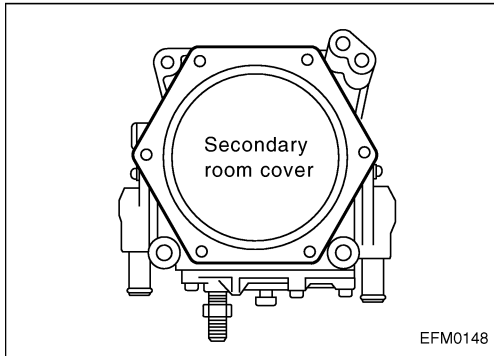

DISASSEMBLY OF SECONDARY CHAMBER SIDE

- The figure shows that secondary chamber side is assembled.
- Secondary chamber cover is fixed by 6 screws. Secondary chamber cover can be removed by loosening each screw.

- The figure shows the condition that secondary chamber cover is removed.

DISASSEMBLY OF HIGH-PRESSURE SIDE COVER

- Loosen and remove high-pressure side cover mounting screws (8).

INSPECTION OF PRIMARY SIDE VALVE

- Check around primary side valve and valve seat.
- Check valve lever for smooth operation.
- Check valve and lever assembly if necessary.

INSPECTION OF DIAPHRAGM

- Check for cracks, damage and hardening.
- Replace each diaphragm if necessary.

PREPARATION

Special Service Tools

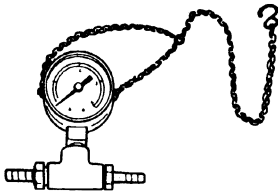
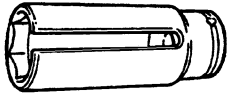
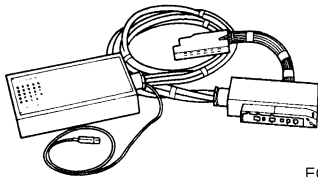
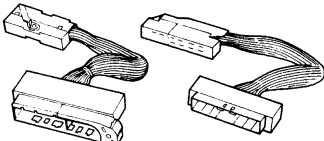
Description		Application
 <p>ECM0013</p>	EGI fuel pressure indicator ST19590000	For measuring fuel pressure gauge
 <p>ECM0014</p>	Heated oxygen sensor wrench KV10113700	Removing and installing heated oxygen sensor
	DIAGNOSIS KIT 29498 FK100	For system inspection and diagnosis
 <p>ECM0016</p>	Check adapter V EG1755000 (for SMJ 150-pin connector)	For control unit input/output signal inspection
 <p>ECM0017</p>	Harness adapter EG17550200 (150-pin to 121-pin conversion adapter)	

TROUBLE DIAGNOSIS

Circuit Diagram

K-ENGINE ELECTRONIC CONTROLLED ECM CIRCUIT DIAGRAM (COMBINED GASOLINE AND LPG)

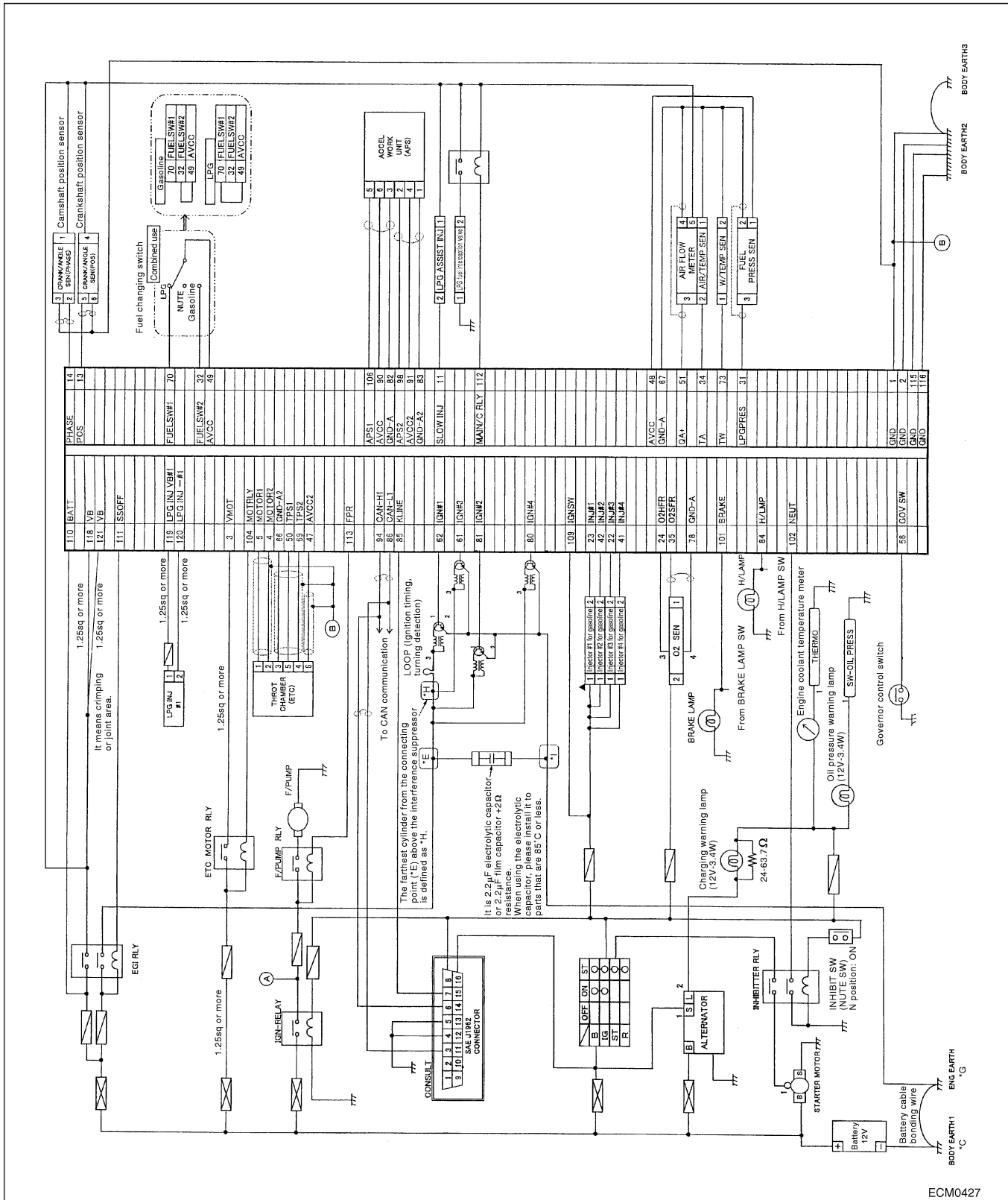

ECM0427

TROUBLE DIAGNOSIS

How to Proceed with Trouble Diagnosis (Cont'd)

Trouble Diagnosis Information Memo

Memo serial No.	
Date	No.

Issue of memo	

Date of occurrence		Weather:		Location:		Operator:						
Vehicle type		Model class	Vehicle ID No.	Model year	Travel time	Engine type	No. stamped on engine	Fuel	Transmission	Heater	Oil pump capacity (cc)	A/C
Vehicle model	Type	(in-house code)			(hr.)			<input type="checkbox"/> Gasoline <input type="checkbox"/> LPG <input type="checkbox"/> Propane <input type="checkbox"/> Fuel ratio <input type="checkbox"/> Fuel supplier <input type="checkbox"/> Combined use	<input type="checkbox"/> M/T (gear) <input type="checkbox"/> A/T	<input type="checkbox"/> Yes <input type="checkbox"/> No	<input type="checkbox"/> Yes <input type="checkbox"/> No	<input type="checkbox"/> Yes <input type="checkbox"/> No

Trouble diagnosis condition item	Description (Enter a check mark, value, or comment in the dashed or solid-line box for the applicable item.)		
Symptom	<input type="checkbox"/> 1 Poor starting	<input type="checkbox"/> a Cranking not possible <input type="checkbox"/> b No initial combustion <input type="checkbox"/> c Does not start smoothly. <input type="checkbox"/> d Does not start at all.	
	<input type="checkbox"/> 2 Poor idle	<input type="checkbox"/> a Does not start at all. <input type="checkbox"/> b Inconsistent <input type="checkbox"/> c Hunting (steady speed fluctuation)	
	<input type="checkbox"/> 3 Engine stall	<input type="checkbox"/> a Occurs without a symptom. <input type="checkbox"/> b Occurs after engine stumbles. <input type="checkbox"/> c Stalls but restarts quickly. <input type="checkbox"/> d Occurs when steering. <input type="checkbox"/> e Occurs when loading. <input type="checkbox"/> f Occurs after cold start.	
	<input type="checkbox"/> 4 Poor power output	<input type="checkbox"/> a Poor hill-climbing ability <input type="checkbox"/> b Insufficient speed <input type="checkbox"/> c Loading not possible <input type="checkbox"/> d Loading slow, difficult to operate <input type="checkbox"/> e Inappropriate lifting speed during lifting control <input type="checkbox"/> f Governor hunting	
	<input type="checkbox"/> 5 Poor acceleration		
	<input type="checkbox"/> 6 Hesitation		
	<input type="checkbox"/> 7 Surge (vibration in fwd and bwd direction)		
	<input type="checkbox"/> 8 Knocking (pinging sound)		
	<input type="checkbox"/> 9 Backfire (blowback noise)		
	<input type="checkbox"/> 10 After-burn (exhaust detonation)		
	<input type="checkbox"/> 11 Poor fuel economy		<input type="checkbox"/> (LPG hr./tank) <input type="checkbox"/> 12 Poor oil economy (hr./L)
	<input type="checkbox"/> 13 Overheat		<input type="checkbox"/> a Not overheated, but engine coolant temperature gauge indicates high. <input type="checkbox"/> b Overheated
	<input type="checkbox"/> 14 Coolant/oil leakage		Location: _____
	<input type="checkbox"/> 15 Noise		Location: _____
	<input type="checkbox"/> 16 Warning lamp illumination	<input type="checkbox"/> a No <input type="checkbox"/> b Yes	

First occurrence	<input type="checkbox"/> 1 With new vehicle <input type="checkbox"/> 2 Recently Approx. date: _____ <input type="checkbox"/> 3 After brought back for servicing Approx. date: _____
------------------	---

Frequency of occurrence	<input type="checkbox"/> 1 At all times <input type="checkbox"/> 2 Under certain conditions <input type="checkbox"/> 3 Sometimes
-------------------------	--

Conditions of vehicle	Temperature condition	<input type="checkbox"/> 1 Temperature (°C)	<input type="checkbox"/> 2 Humidity (%)	
		<input type="checkbox"/> 3 Coolant temp.	<input type="checkbox"/> Cold engine <input type="checkbox"/> When engine is warming up <input type="checkbox"/> High coolant temp.	
		<input type="checkbox"/> 4 Engine compartment temp.	_____ °C	
	Operating condition, etc.	<input type="checkbox"/> 1 Irrelevant <input type="checkbox"/> 2 At idle <input type="checkbox"/> 3 With engine racing		
		<input type="checkbox"/> 4 During acceleration		
		<input type="checkbox"/> 5 At constant speed		
		<input type="checkbox"/> 6 During deceleration		
		<input type="checkbox"/> 7 When going up a hill		
		<input type="checkbox"/> 8 When loading		
<input type="checkbox"/> 9 Unladen <input type="checkbox"/> Tilting <input type="checkbox"/> Lifting <input type="checkbox"/> Steering				
<input type="checkbox"/> 10 Laden Capacity _____ kg, lbs. <input type="checkbox"/> Tilting <input type="checkbox"/> Lifting <input type="checkbox"/> Steering				
<input type="checkbox"/> 11 Other <input type="checkbox"/> Inching/braking <input type="checkbox"/> Steering <input type="checkbox"/> Other				

Attachment	<input type="checkbox"/> 1 Standard <input type="checkbox"/> 2 Side shifter <input type="checkbox"/> 3 Hinged fork <input type="checkbox"/> 4 Bale clamp
	<input type="checkbox"/> 5 Roll clamp <input type="checkbox"/> 6 Rotating fork <input type="checkbox"/> 7 Stabilizer <input type="checkbox"/> 8 Other

Other; Enter comments, etc.	
-----------------------------	--

ECM0037

TROUBLE DIAGNOSIS

Table of DTC (Cont'd)

DTC	Display screen	Name	Engine warning lamp
E-23	G 1 ** . E - 2 3 * * * * * . * ** T H R O T T L E S E N S O R E R R	Throttle position sensor signal circuit malfunction	ON*
E-24	G 1 ** . E - 2 4 * * * * * . * ** A C C E L S E N S O R E R R	Accelerator pedal position sensor signal circuit malfunction	—
E-25	G 1 ** . E - 2 5 * * * * * . * ** O 2 S E N S O R E R R	Heated oxygen sensor signal circuit malfunction	—
E-26	G 1 ** . E - 2 6 * * * * * . * ** O 2 S E N S O R H E A T E R E R R	Heated oxygen sensor heater signal malfunction	—

TROUBLE DIAGNOSIS

ECM Input/Output Monitor

In ECM input/output monitor, the items related to engine control (engine status, sensors or switches) can be checked.

Items	Display screen	Name	Remarks (Display, etc.)
A2-01 (Upper)	A2 ENG. REV 1238 r/dm 01 IDLE SW OFF	Engine speed	Idle speed: 700 rpm, maximum engine speed without load: 2,800 rpm
A2-01 (Lower)		Closed throttle position switch	Accelerator fully-closed: ON, accelerator open: OFF
A2-02 (Upper)	A2 THROTTLE ANGLE 40% 02 BAT VOL. 10000mV	Throttle opening angle	At idle: 0%, accelerator fully-open: 100%
A2-02 (Lower)		Battery voltage	
A2-03 (Upper)	A2 ACCEL ANGLE 74% 03 COOLANT TEMP 100°C	Accelerator pedal position	At idle: 0%, accelerator fully-open: 100%
A2-03 (Lower)		Engine coolant temperature	Approx. 80°C (176°F) or more after warming up engine
A2-04 (Upper)	A2 INJPULSE GAS 100µs 04 INJPULSE LPG 100µs	Injection pulse GAS	At idle: 2-4 µs
A2-04 (Lower)		Injection pulse LPG	At approx. 2,000 rpm: Approx. 2 - 4 µs
A2-05 (Upper)	A2 START SW OFF 05 NEUTRAL SW OFF	Starter switch	Ignition switch ON and START: ON, ignition switch OFF: OFF
A2-05 (Lower)		Neutral switch	FR lever in neutral: ON, any position other than neutral: OFF
A2-06 (Upper)	A2 ELEC LOAD SW OFF 06 BRAKE SW OFF	Electricity load switch	Headlamp switch ON: ON, OFF: OFF
A2-06 (Lower)		Brake switch	Depressing brake pedal: ON, Not depressing brake pedal: OFF
A2-07 (Upper)	A2 AIRCON SW OFF 07 A/F ALPHA CLR DONE	Air conditioner switch	Not specified
A2-07 (Lower)		Learned Air-fuel ratio value clear	DONE/NOT
A2-08 (Upper)	A2 IDLE AIR VOL F EXE 08 IDLE AIR VOL N EXE	Idle Air Volume Learning (Factory)	Not used
A2-08 (Lower)		Idle Air Volume Learning (Normal)	EXE/NOT
A2-09 (Upper)	A2 IGN TIMING ADJ EXE 09 A/F ALPHA ADJ EXE	Ignition timing adjustment	EXE/NOT
A2-09 (Lower)		Air-fuel ratio adjustment	EXE/NOT
A2-10 (Upper)	A2 POWER BALANCE EXE 10 FUEL PRES CLR EXE	Power balance adjustment	EXE/NOT
A2-10 (Lower)		Fuel pressure clear adjustment	EXE/NOT
A2-11 (Upper)	A2 SELF-DIAG CLR DONE 11 AIR FLOW 150mV	Self-diagnosis result clear	DONE/NOT
A2-11 (Lower)		Mass air flow sensor	At idle: Approx. 1.3V, engine speed at 2,000 rpm: Approx. 1.6V
A2-12 (Upper)	A2 CHARG EFF GAS 100% 12 CHARG EFF LPG 100%	Charging efficiency GAS	At idle: Approx. 30%, At approx. 2,000 rpm: Approx. 20%
A2-12 (Lower)		Charging efficiency LPG	At idle: Approx. 30%, At approx. 2,000 rpm: Approx. 20%
A2-13 (Upper)	A2 A/F ALPHA GAS 100% 13 A/F ALPHA LPG 100%	Air-fuel ratio (Gasoline)	Proper value: 100%, range: 75 - 125%
A2-13 (Lower)		Air-fuel ratio (LPG)	Proper value: 100%, range: 75 - 125%
A2-14 (Upper)	A2 CHG FUEL SW1 OFF 14 CHG FUEL SW2 OFF	Change fuel switch 1	LPG: ON, GAS: OFF
A2-14 (Lower)		Change fuel switch 2	GAS: ON, LPG: OFF
A2-15 (Upper)	A2 FUEL CONTROL GAS 15 MAST HIGH SW1 OFF	Fuel control	GAS/LPG/NEU
A2-15 (Lower)		Mast high switch 1	Not specified
A2-16 (Upper)	A2 MAST HIGH SW2 OFF 16 O2 SENSOR LEAN	Mast high switch 2	Not specified
A2-16 (Lower)		O2 sensor RICH/LEAN judgement	While the engine is running: Switches between LEAN/RICH
A2-17 (Upper)	A2 FUELPUMP RELAY OFF 17 LPG RELAY OFF	Fuel pump relay	Ignition switch ON (when the fuel pump is operating), OFF (when the fuel pump is stopped)
A2-17 (Lower)		LPG interception valve relay	When the engine is stopped: OFF, while the engine is running: ON
A2-18 (Upper)	A2 THROTTLE RELAY OFF 18 O2 SEN HEATER OFF	Throttle relay	Ignition switch ON: ON, OFF: OFF
A2-18 (Lower)		Heated oxygen sensor heater	At idle after warming up the engine: ON
A2-19 (Upper)	A2 OFF ACCEL PO. DONE 19 IDLE AIR COMP DONE	Fully-closed learning update empirical flag	DONE/NOT
A2-19 (Lower)		Idle Air Volume Learning (Factory/Normal) completion flag	DONE/NOT
A2-20 (Upper)	A2 CON CONSULT II OFF 20 IGN TIMING 0deg	CONSULT-II connecting flag	ON/OFF
A2-20 (Lower)		Ignition timing	Proper value: 0 (at idle), range: 0 - 10 NOTE: When the display is "99", it means a minus.

Throttle Valve Closed Position Learning and Idle Air Volume Learning

DESCRIPTION

When electric throttle control actuator or ECM connector is removed, it is necessary for ECM to learn throttle valve closed position (throttle position sensor output with throttle valve fully closed) after reinstallation. Thus, throttle valve closed position learning is performed.

When electric throttle control actuator or ECM is replaced, the minimum required idle air volume needs to be learned. Thus, throttle valve closed position learning and idle air volume learning are performed.

Idle air volume learning is necessary even when idle speed or ignition timing is outside the standard. Note that idle air volume learning is equivalent to the base idle speed adjustment by conventional throttle adjusting screw of carburetor or LPG mixer.

OPERATION PROCEDURE FOR THROTTLE VALVE CLOSED POSITION LEARNING

1. Turn ignition switch ON → OFF. (And hold it for approximately 5 seconds after turning it OFF.)
2. Make sure that throttle valve operates. (Check for operating sound.)
3. Upon completion of the above, learning is complete.



CAUTION:

Throttle valve closed position learning cannot be performed with Service tool.

OPERATION PROCEDURE FOR IDLE AIR VOLUME LEARNING

1. Perform throttle valve closed position learning.
2. Fully warm up engine, transmission, and lubricant. [Engine coolant temperature: 70 to 90°C (158 to 194°F)]
3. Set the selector lever to neutral or N position. Make sure that the engine is free of electrical loads, such as air conditioner, oil pressure pump, and other electrical components.
4. Perform "Idle Air Volume Learning" of "ECM Active Test". (Refer to EC-47.)



CAUTION:

"IDLE AIR VOL LEARN (PLANT)" is the original setting on the vehicle. Do not use it.

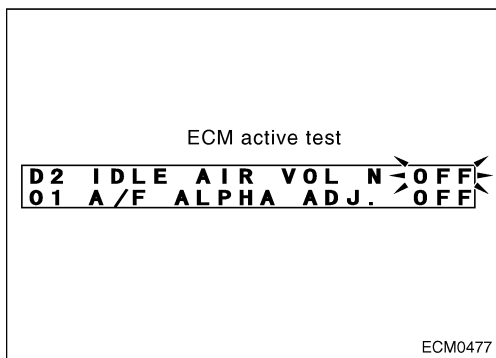

Removal and Installation

ECM

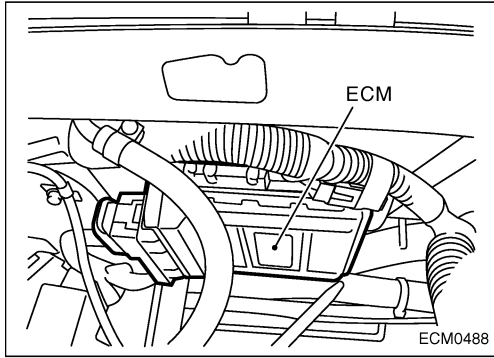

CAUTION:

Disconnect the negative battery cable from the battery.

1. Disconnect ECM connector.
2. Remove ECM together with ECM bracket.
3. Remove ECM bracket.
4. Install in the reverse order of removal.



CAUTION:

Perform "Throttle Valve Closed Position Learning and Idle Air Volume Learning" after installation if replacing ECM. (Refer to EC-56, "Throttle Valve Closed Position Learning and Idle Air Volume Learning".)

CRANKSHAFT POSITION SENSOR (POS)

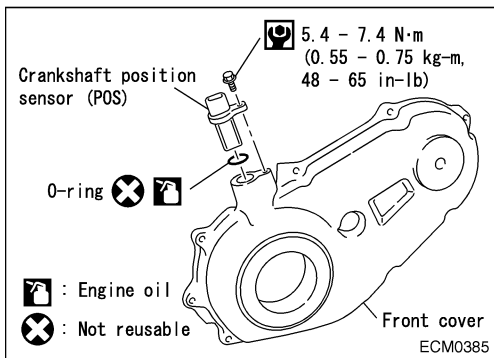

1. Remove fan.
2. Remove harness connector.
3. Remove crankshaft position sensor (POS).

NOTE:

- Make sure that there is no foreign material on sensor flange, O-rings, and cylinder block.
- Keep away from magnetized objects.
- Make sure that the sensor is inserted securely into front cover before tightening bolts.

CAMSHAFT POSITION SENSOR (PHASE)

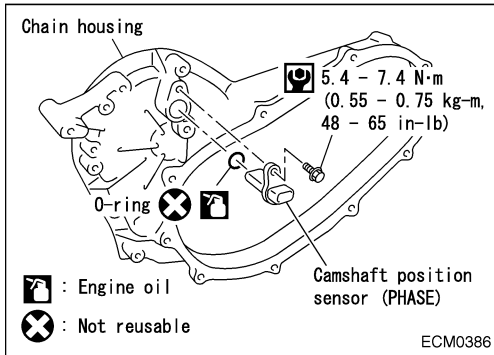

1. Remove fan.
2. Remove harness connector.
3. Remove camshaft position sensor (PHASE).

NOTE:

- Make sure that there is no foreign material on sensor flange, O-rings, and chain housing.
- Keep away from magnetized objects.
- Make sure that the sensor is inserted securely into cylinder head front cover before tightening bolts.

MASS AIR FLOW SENSOR

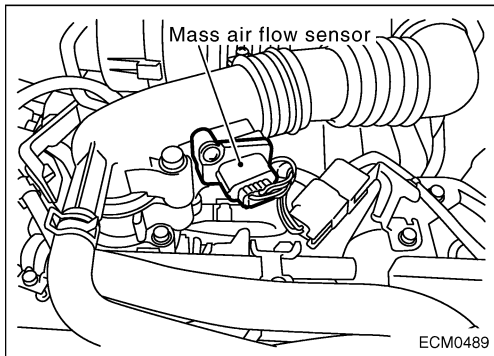

1. Remove harness connector.
2. Remove mass air flow sensor assembly from air horn.

STARTER MOTOR



CAUTION:

- Before starting any electrical system service, make sure to turn off the key switch and disconnect the battery cable.

Starter Motor Specifications

Items	Specification
Part type	M000T65381
Type	Integrated reduction gears
Output	1.2 kW

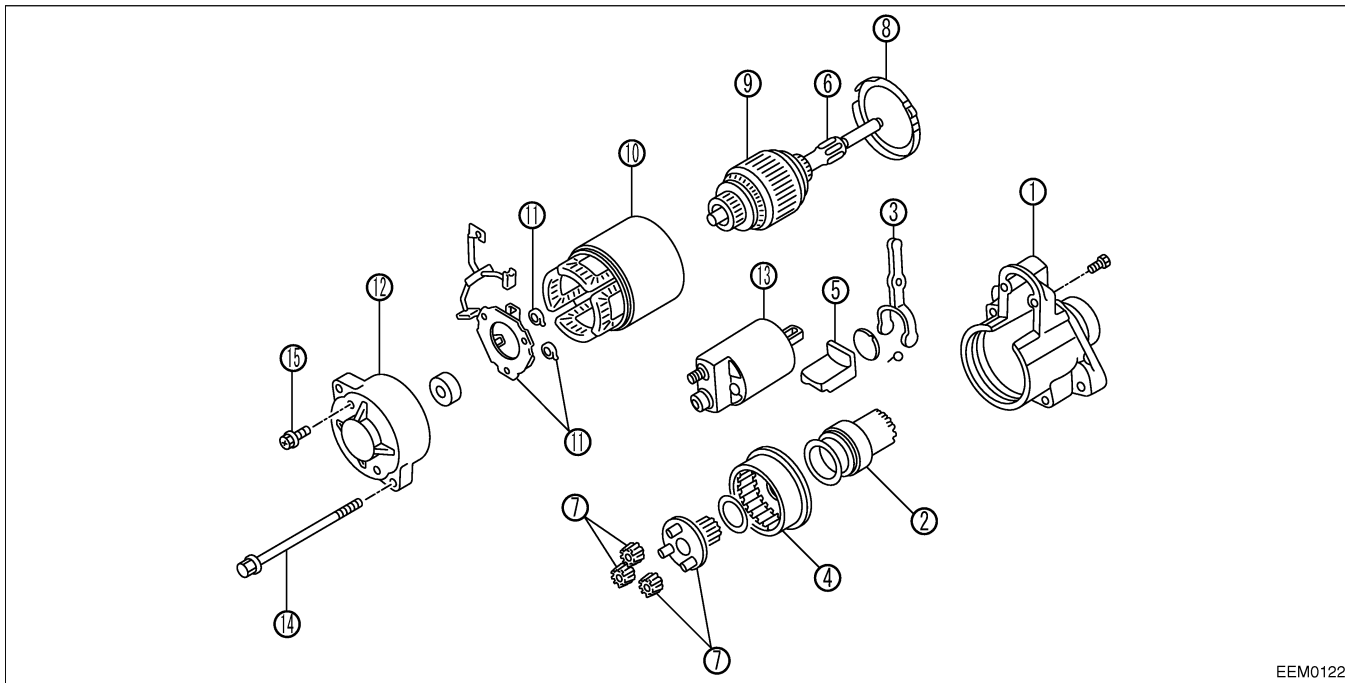

EEM0122

Component Parts Location

Major components of starter motor

Symbol	Description
(1)	Front bracket
(2)	Overrunning clutch
(3)	Lever
(4)	Internal gear
(5)	Packing
(6)	Shaft gear
(7)	Gear assembly
(8)	Packing
(9)	Armature
(10)	Yoke assembly
(11)	Connector brush holder assembly
(12)	Rear blanket
(13)	Switch assembly
(14)	Hexagon head bolt
(15)	Flange screw

Inspection (Cont'd)

NOTE:

Rectifier condition cannot be judged by forward resistance. One of the characteristics of a diode is that forward current is greatly changed by battery voltage. Indication of tester changes with differences of tester type and resistance range. Rectifier condition is judged by resistance differences between forward and reverse currents.

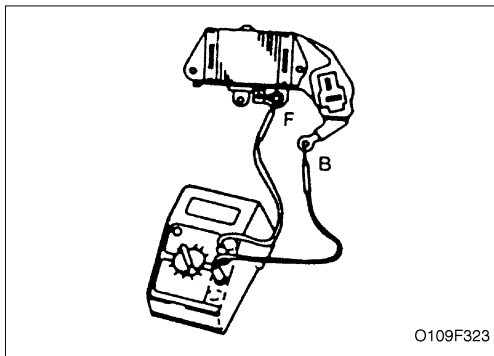
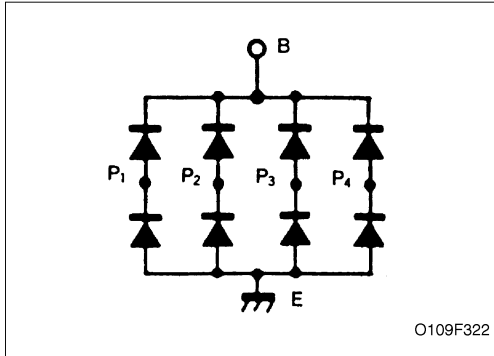

IC REGULATOR

Check continuity between IC regulator terminal B and F with circuit tester in $k\Omega$ range.

- It is normal that continuity should exist in one side and continuity should not exist in another side.



CAUTION:

- **Do not use 500V mega tester that breaks IC regulator.**

NOTE:

IC regulator can be checked with the following procedure if there is constant voltage power supply that can change voltage between 10 to 20V range.



CAUTION:

- **Regulator may be destroyed if IC regulator misconnects only for a moment. Perform inspection after checking wiring.**
- Connect IC regulator unit with constant voltage power supply, circuit tester, and lamps.
- (SW1 and SW2 must remain OFF.)
- Set a power supply voltage to 12V.
- Set SW1 setting to ON. Make sure that L1 turns ON brightly, and L2 turns ON dimly at this time.
- Next, turn SW2 to NO while leaving SW1 at ON. Make sure that L1 turns OFF, and L2 turns ON brightly at this time.
- Raise battery voltage from 12V gradually. Make sure that L2 may turn OFF when battery voltage is approximately $14.5 \pm 0.6V$.

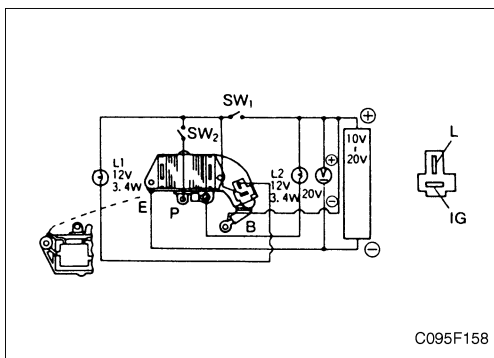

TIGHTENING TORQUE

Standard Bolt Tightening Torque (Cont'd)

TAPER SCREW TIGHTENING TORQUE

Normal size	Allowable materials for tightening				
	Unit	Aluminum		Cast iron	
		Standard	Max. value	Standard	Max. value
R1/8	N·m	7.8	11.8	15.7	21.6
	kg·m	0.796	1.2	1.6	2.2
	ft·lb, in·lb*	69*	9	12	16
R1/4	N·m	19.6	29.4	34.3	44.1
	kg·m	2.0	3.0	3.5	4.5
	ft·lb	14	22	25	33
R3/8	N·m	39.2	54.9	53.9	73.5
	kg·m	4.0	5.6	5.5	7.5
	ft·lb	29	41	40	33

TROUBLE DIAGNOSES AND CORRECTIONS

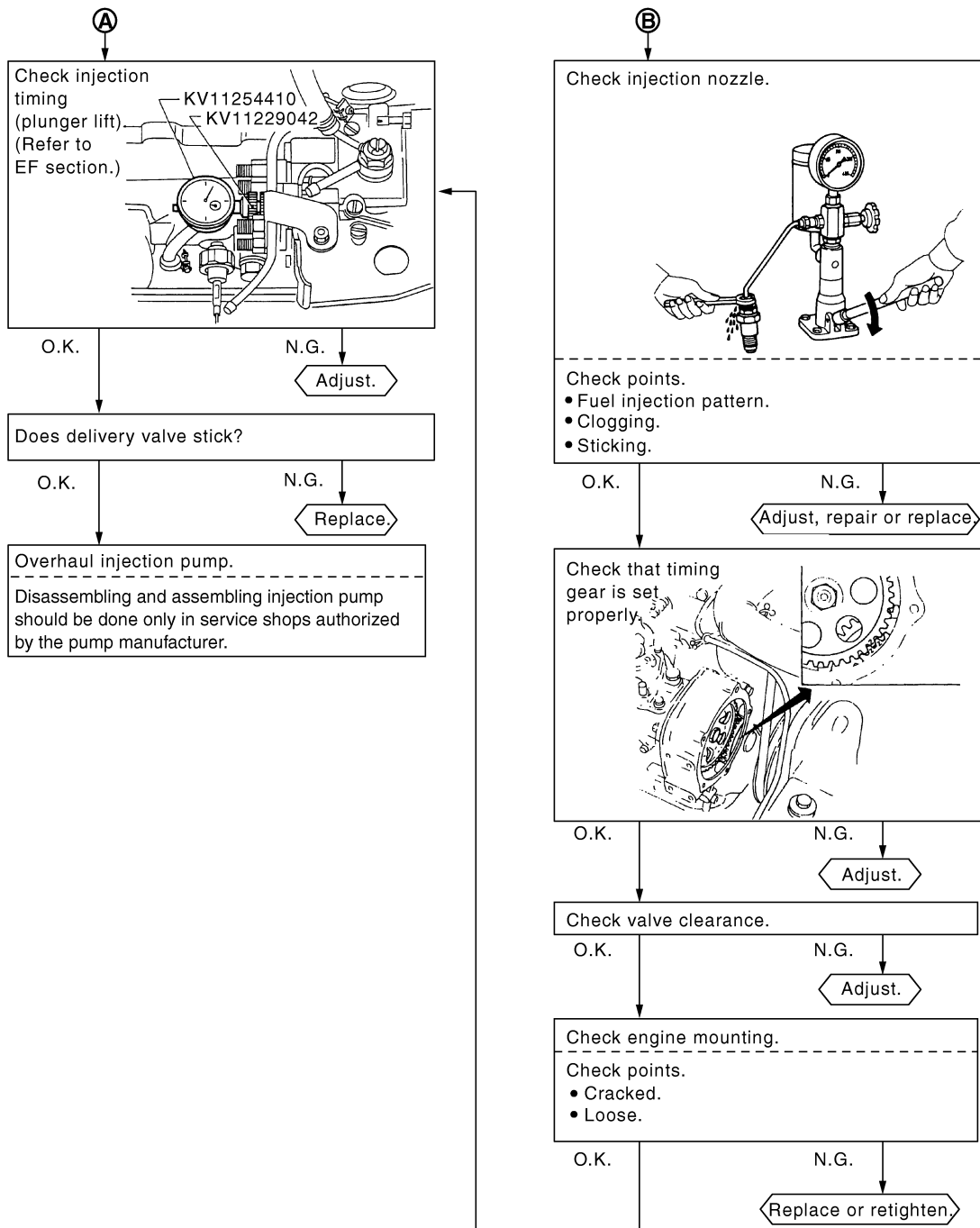

ETM0124

TROUBLE DIAGNOSES AND CORRECTIONS

Basic Mechanical System (Cont'd)

CHECKING AND ADJUSTING DRIVE BELTS

1. Visually inspect for cracks or damage.
The belts should not touch the bottom of the pulley groove.
2. Check drive belt deflection by pushing. The belts should deflect by the specified amount.

Drive belt deflection:

		Used	New
Fan belt	mm(in)	11 - 13 (0.43 - 0.51)	9 - 11 (0.35 - 0.43)
Applied pushing force N (kg, lb)		98 (10, 22)	

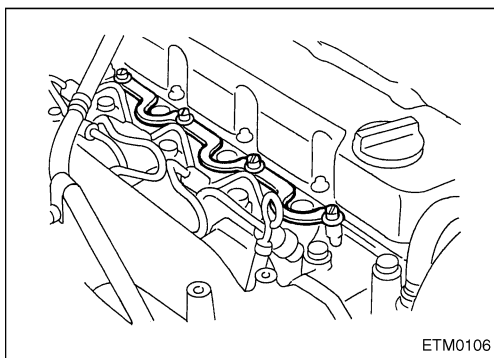
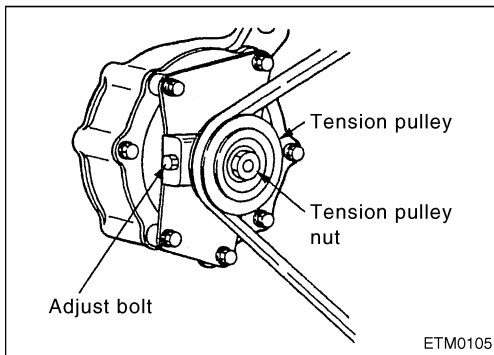
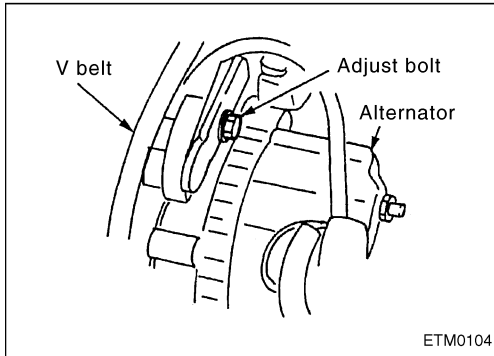
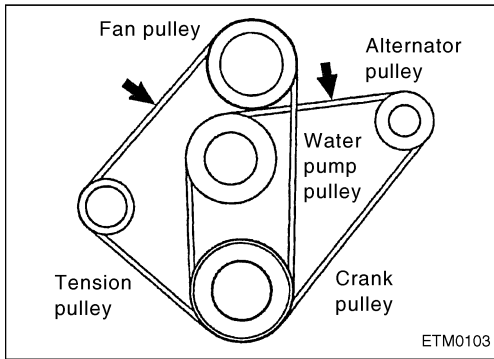

CHECKING ENGINE COMPRESSION PRESSURE

1. Warm up engine.
2. Remove glow plate or injection nozzle.
3. Fit compression gauge adapter to cylinder head. Make sure bleeder screw of gauge is closed.

Compression gauge adapter

For glow plug hole

15 - 20 N•m (1.5 - 2.0 kg-m, 11 - 14 ft-lb)

SERVICE DATA AND SPECIFICATIONS

Inspection and Adjustment (Cont'd)

CYLINDER HEAD TO VALVE DISTANCE

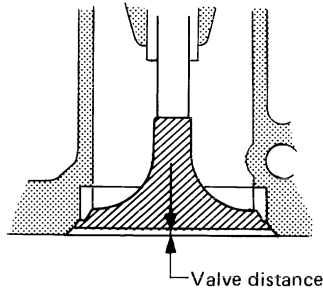

EMM0568

Item		Standard	Limit
Intake	mm (in)	0.7 - 1.3 (0.028 - 0.051)	1.70 (0.067)
Exhaust	mm (in)	0.7 - 1.3 (0.028 - 0.051)	1.70 (0.067)

VALVE SEAT

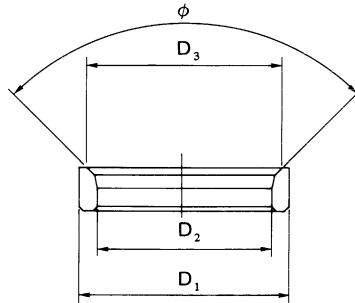

EMM0569

Intake	Outer diameter "D ₁ "	mm (in)	46.535 - 46.545 (1.8321 - 1.8325)	
	Inner diameter "D ₂ "	mm (in)	39.4 - 39.6 (1.551 - 1.559)	
	Diameter of seat "D ₃ "	mm (in)	45.3 - 45.7 (1.783 - 1.799)	
	Cylinder head valve seat diameter	mm (in)	46.500 - 46.515 (1.8307 - 1.8313)	
	Valve seat face angle "φ"		89° - 90°	
Exhaust	Outer diameter "D ₁ "	mm (in)	Standard	40.535 - 40.545 (1.5959 - 1.5963)
		0.2 (0.008) Oversize (Service)	40.735 - 40.745 (1.6037 - 1.6041)	
		0.4 (0.016) Oversize (Service)	40.935 - 40.945 (1.6116 - 1.6120)	
	Inner diameter "D ₂ "	mm (in)	33.65 - 34.35 (1.3248 - 1.3524)	
	Diameter of seat "D ₃ "	mm (in)	37.9 - 38.1 (1.492 - 1.500)	
	Cylinder head valve seat diameter	mm (in)	Standard	40.495 - 40.510 (1.5943 - 1.5949)
		0.2 (0.008) Oversize	40.695 - 40.710 (1.6022 - 1.6028)	
0.4 (0.016) Oversize		40.895 - 40.910 (1.6100 - 1.6106)		
Valve seat face angle "φ"		89° - 90°		

CYLINDER HEAD

Inspection (Cont'd)

VALVE GUIDE CLEARANCE

Valve guide clearance should be measured parallel with rocker arm. (Generally, a large amount of wear occurs in this direction.)

Stem to guide clearance:

Limit

Intake 0.15 mm (0.0059 in)

Exhaust 0.20 mm (0.0079 in)

Maximum allowable deflection

(Dial indicator reading)

Intake 0.30 mm (0.0118 in)

Exhaust 0.40 mm (0.0157 in)

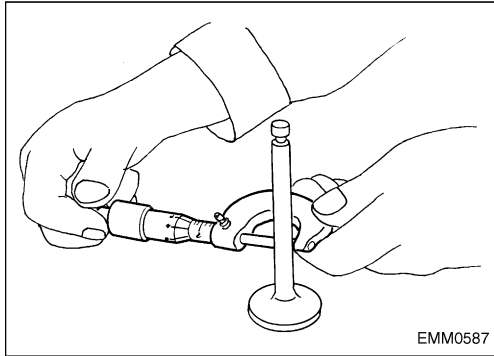
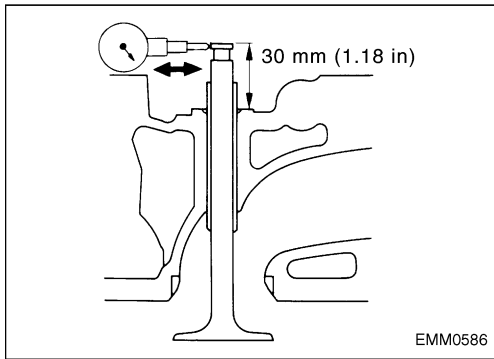

NOTE:

To determine the correct replacement part, measure valve stem diameter and valve guide inner diameter.

Valve stem diameter:

8.0 mm (0.315 in)

Valve guide inner diameter:

8.000 - 8.015 mm (0.3150 - 0.3156 in)

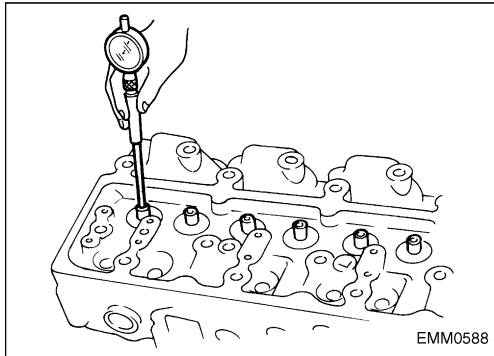

VALVE GUIDE REPLACEMENT

1. Drive out valve guide with a press [under a 20 kN (2 ton, 2.2 US ton, 2.0 Imp ton) pressure] or hammer, and suitable tool.

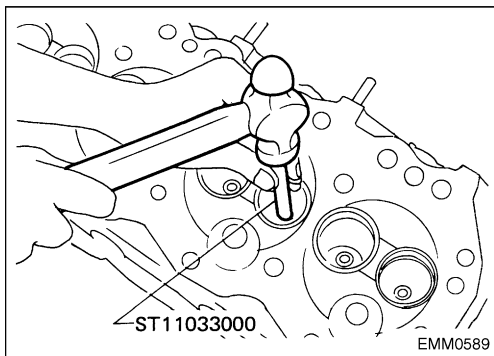

OIL SEAL

Replacement (On-vehicle service)

OIL SEAL INSTALLING DIRECTION

When installing a new front or rear seal, make sure its mounting direction is correct.

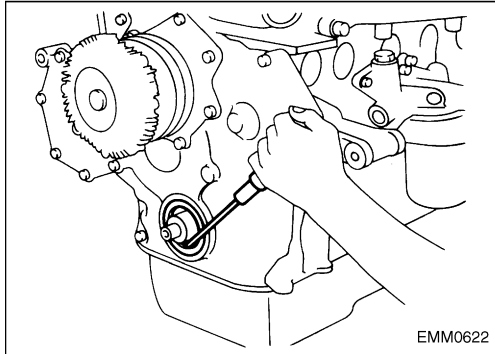
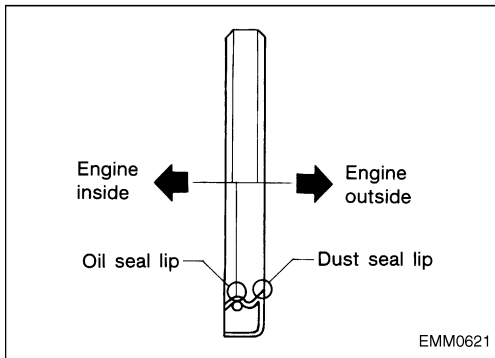

CRANKSHAFT FRONT OIL SEAL

1. Remove counterweight.
2. Remove radiator shroud and radiator.
3. Remove muffler.
4. Remove cooling fan.
5. Remove drive belts.
6. Remove crank pulley.
7. Remove crankshaft oil seal.



Be careful not to damage sealing surfaces of crankshaft.

8. Coat new oil seal with engine oil and install it in place.

VALVE STEM OIL SEAL

1. Remove rocker cover.
2. Remove rocker shaft assembly.
3. Remove valve spring.

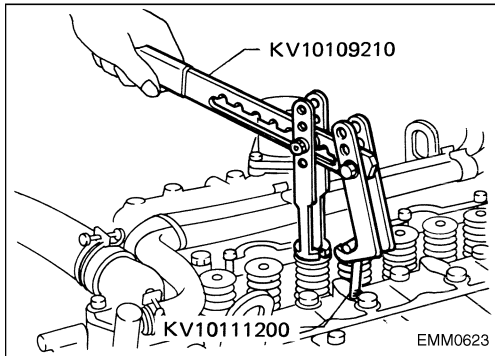

4. Remove valve oil seals.

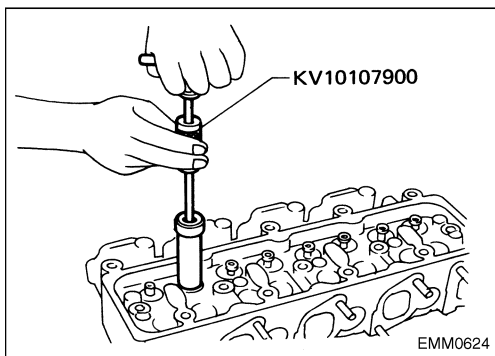

Inspection and Replacement (Cont'd)

RESURFACING OF CRANKSHAFT JOURNAL AND CRANK PIN

When using undersize main bearings and connecting rod bearings, the crankshaft journals or crank pins must be finished to match the bearings.

R:

Crank journal:
3.0 mm (0.118 in)

Crank pin:
3.5 mm (0.138 in)

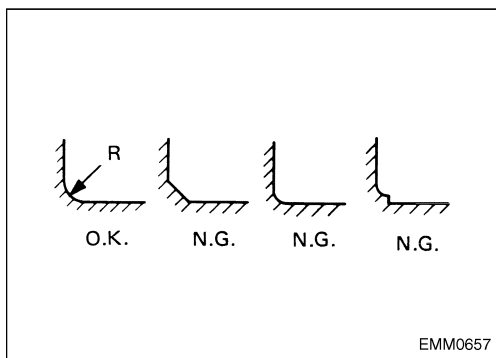

CAUTION:

- At the same time make sure that the surface width does not increase.
- Do not attempt to cut counterweight of crankshaft.

FLYWHEEL RUNOUT

Runout (Total indicator reading):
Less than 0.15 mm (0.0059 in)

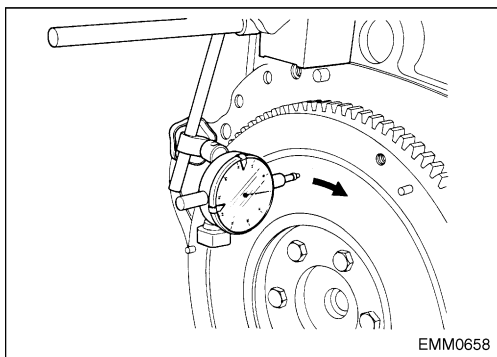

FRONT PLATE

Check front plate for warpage. If not within the limit, make flat or replace front plate.

Warpage limit:
0.2 mm (0.008 in)

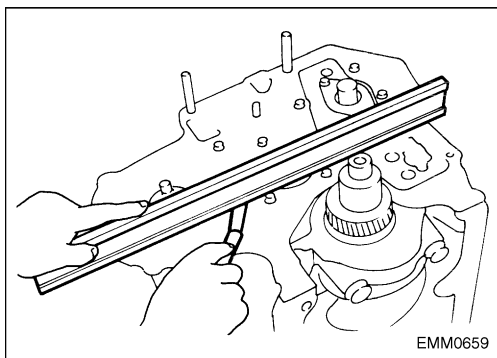

Assembly (Cont'd)

GEAR TRAIN

1. Set No. 1 piston at its top dead center.
2. Align each gear mark and install gears.

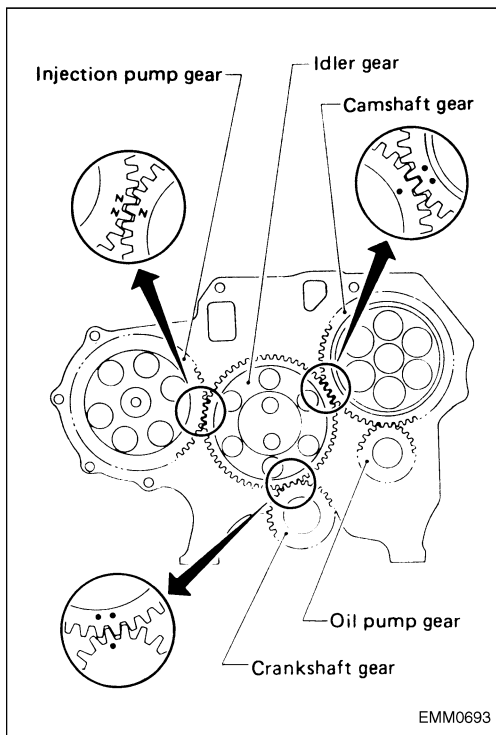

TIMING GEAR CASE

Installation

1. Before installing timing gear case, remove all traces of liquid gasket from mating surface using a scraper. Also remove traces of liquid gasket from mating surface of front plate.
2. Apply continuous bend of liquid gasket to mating surface of timing gear case.

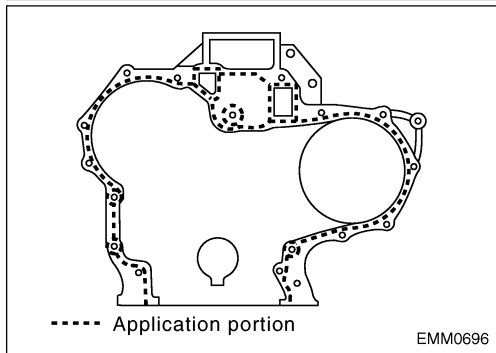
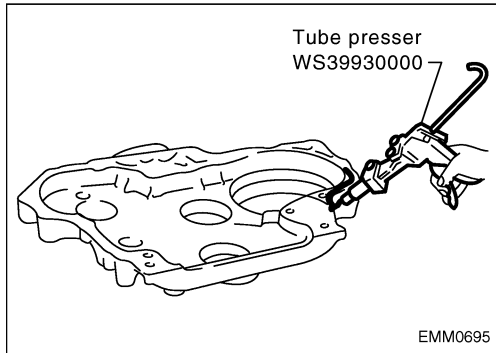
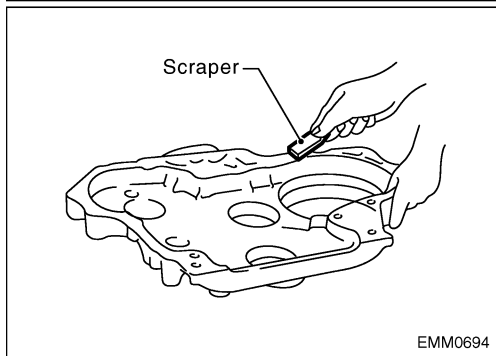

TROUBLE DIAGNOSES AND CORRECTIONS

Engine Cooling System

Condition	Probable cause	Corrective action
Water leakage	Damaged radiator seams.	Repair.
	Water leakage from water pump shaft seal.	Replace as pump assembly.
	Water leakage from water temperature gauge.	Tighten.
	Loose joints.	Tighten.
	Damaged cylinder head gasket.	Check engine oil for contamination.
	Cracked cylinder block.	Replace. Check engine oil in crankcase for mixing with water by pulling oil level gauge.
	Cracked cylinder head.	Replace.
	Loose cylinder head bolts.	Tighten.
Poor circulation	Restriction in system.	Check hoses for crimps, and clear the system of rust and sludge by flushing radiator.
	Insufficient coolant.	Replenish.
	Inoperative water pump.	Replace.
	Loose fan belt.	Adjust.
	Inoperative thermostat.	Replace.
Corrosion	Excessive impurity in water.	Use soft, clean water (rain water is satisfactory).
	Infrequent flushing and draining of system.	Cooling system should be drained and flushed thoroughly. Refer to ET section.
Overheating	Faulty thermostat.	Replace.
	Radiator fin choked with mud, chaff, etc.	Clean out air passage thoroughly by using compressed air.
	Incorrect ignition and valve timing.	Adjust.
	Dirty oil and sludge in engine.	Flush engine and refill oil.
	Inoperative water pump.	Replace.
	Loose fan belt.	Adjust.
	Restricted radiator.	Flush radiator.
	Inaccurate temperature gage.	Replace.
	Impurity in water.	Use soft, clean water.
Overcooling	Faulty thermostat.	Replace.
	Inaccurate temperature gauge.	Replace.
Noise	Squeak at water pump mechanical seal.	Use suitable water pump seal lubricant.
	Damaged or worn water pump bearing.	Replace as pump assembly.

COOLING SYSTEM

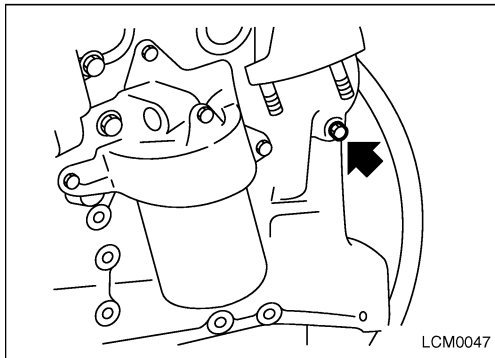

Water Pump

REMOVAL AND INSTALLATION

Drain coolant from drain plugs on cylinder block and radiator.

Cylinder block drain plug

(Use proper sealant):

: 20 - 29 N•m (2.0 - 3.0 kg-m, 14 - 22 ft-lb)

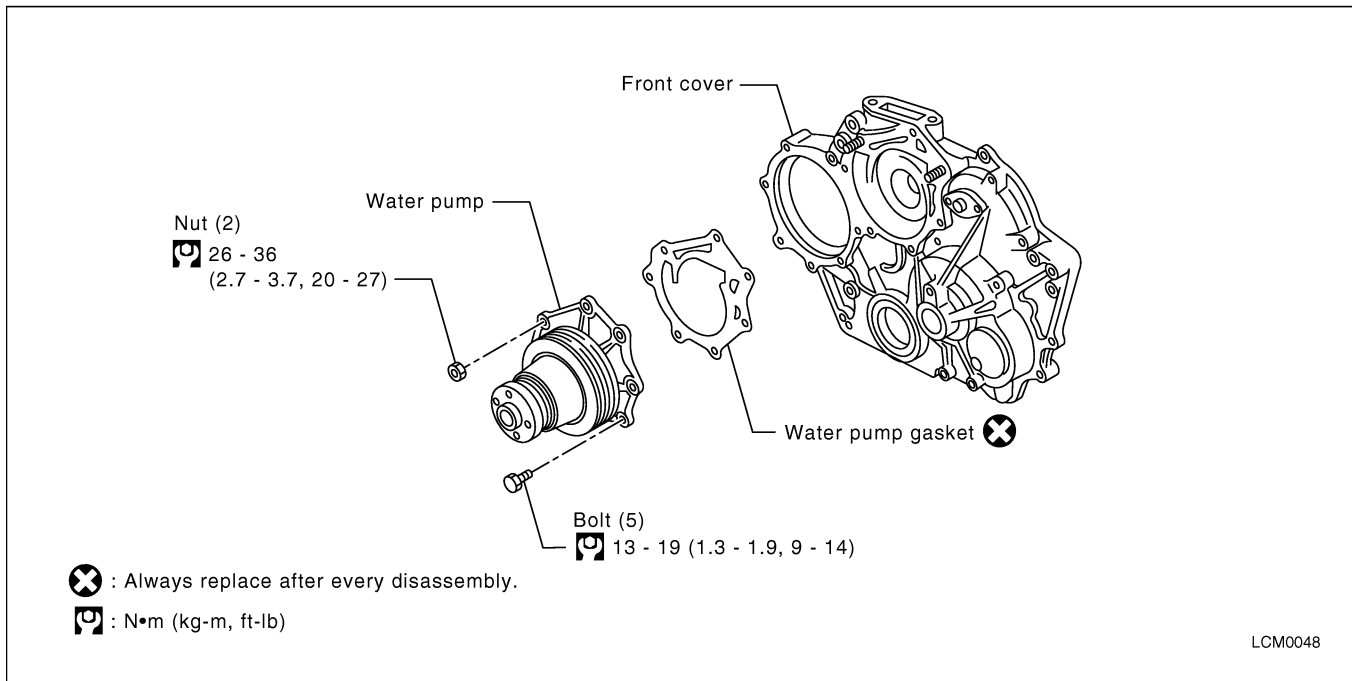

CAUTION:

- When removing water pump assembly, be careful not to get coolant on drive belt.
- Water pump cannot be disassembled and should be replaced as a unit.
- Always replace with new gasket.
- After installing water pump, connect hose and clamp securely, then check for leaks using radiator cap tester.

INJECTION PUMP

Removal (Cont'd)

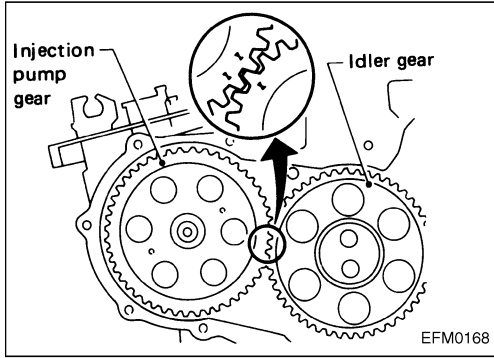

6. Confirm that No. 1 piston is set at T.D.C. on its compression stroke.



CAUTION:

Make sure that "Z" marks are aligned.

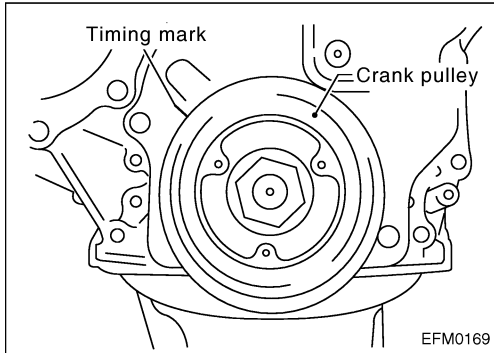

7. Remove rocker cover and observe the intake and exhaust valve positions, and make sure that the matchmarks on front cover and crank pulley are aligned.

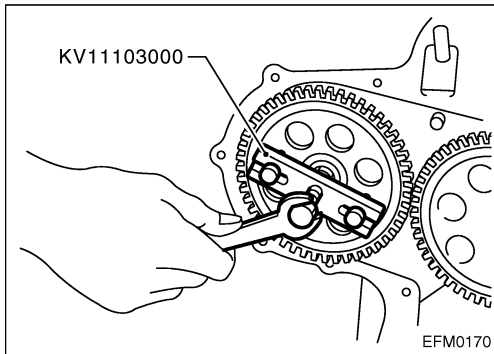

8. Remove injection pump drive gear by using puller.

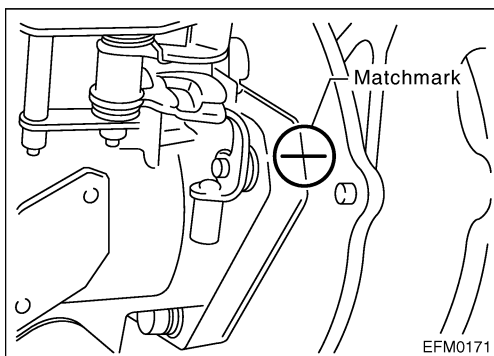

9. Make sure that marks on injection pump and pump bracket are aligned, then remove injection pump.



CAUTION:

Do not turn crankshaft after removing injection pump.

BLEEDING FUEL SYSTEM

Bleeding Fuel System (Engine on vehicle) (Cont'd)

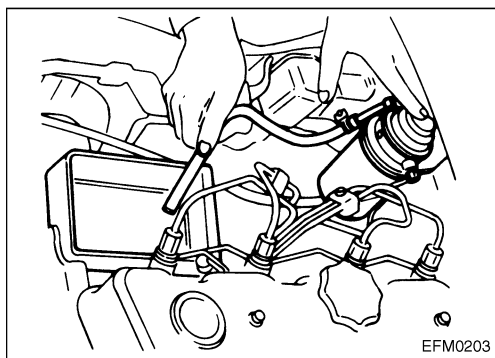
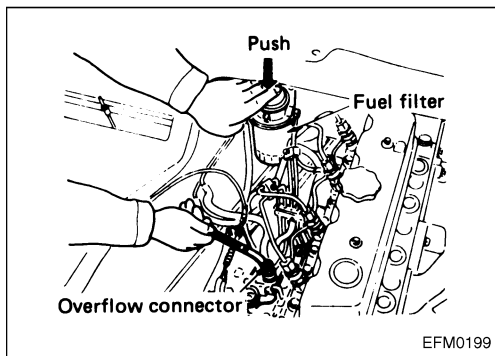
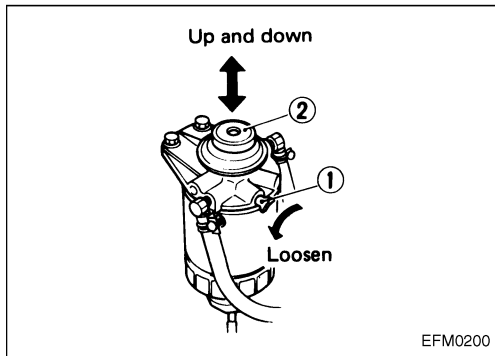

Method B

1. Loosen the air vent screw (1).
2. Move the priming pump (2) up and down until no further airbleed comes out of the air vent screw (1).
3. Tighten the air vent screw (1).
4. Loosen injection pump bleeder screw/or disconnect return hose and priming.
5. Make sure that fuel overflows at bleeder screw/tube end, then tighten it/connect hose.

Checking Priming Pump



CAUTION:

Before checking priming pump, make sure that fuel filter is filled with fuel.

1. Disconnect fuel return hose.



CAUTION:

Place a suitable container beneath hose end.

2. Pump priming pump and check that the fuel overflows from the hose end. If not, replace priming pump.

STARTING SYSTEM



WARNING:

Before starting to work on any part of electrical system, be sure to turn key switch "OFF" and then disconnect battery ground cable.

Wiring Diagram

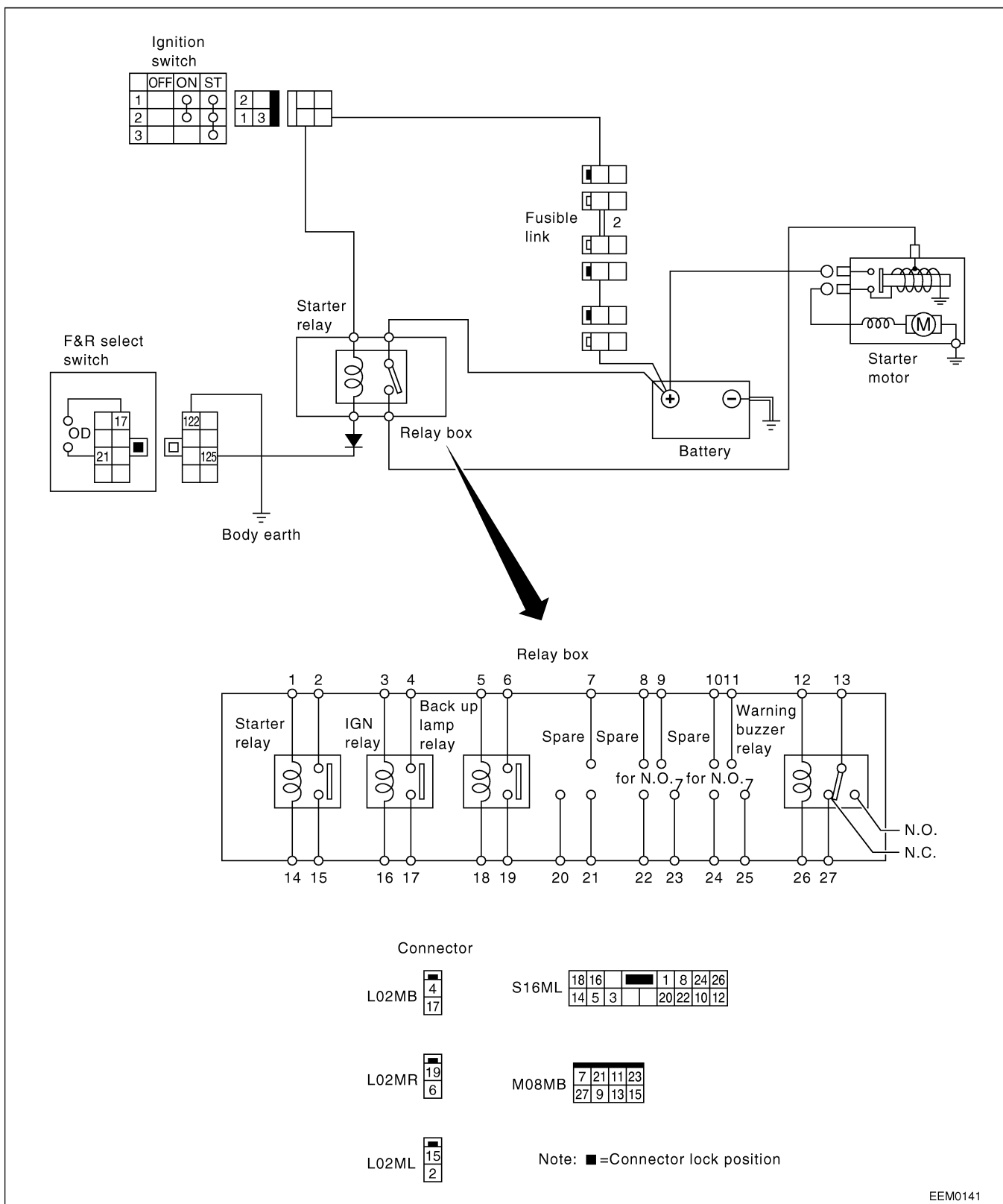

EEM0141

CLICK HERE TO **DOWNLOAD** THE COMPLETE MANUAL

- Thank you very much for reading the preview of the manual.
- You can download the complete manual from: www.heydownloads.com by clicking the link below



- Please note: If there is no response to CLICKING the link, please download this PDF first and then click on it.

CLICK HERE TO **DOWNLOAD** THE COMPLETE MANUAL