

# SERVICE MANUAL

**T7510 / T7520 / T7530**  
**T7540 / T7550**  
Tractor

Part number 47505533  
English  
February 2013

AGRICULTURE

CLICK HERE TO **DOWNLOAD** THE COMPLETE MANUAL

- Thank you very much for reading the preview of the manual.
- You can download the complete manual from: [www.heydownloads.com](http://www.heydownloads.com) by clicking the link below



- Please note: If there is no response to CLICKING the link, please download this PDF first and then click on it.

CLICK HERE TO **DOWNLOAD** THE COMPLETE MANUAL

1. Manufacturer's Identification
2. Property Class
3. Clock Marking of Property Class and Manufacturer's Identification (Optional), i.e. marks **60** ° apart indicate Class 10 properties, and marks **120** ° apart indicate Class 8.

**INCH NON-FLANGED HARDWARE**

NOMINAL SIZE	SAE GRADE 5 BOLT and NUT		SAE GRADE 8 BOLT and NUT		LOCKNUT GrB W/ Gr5 BOLT	LOCKNUT GrC W/ Gr8 BOLT
	UN-PLATED or PLATED SILVER	PLATED W/ZnCr GOLD	UN-PLATED or PLATED SILVER	PLATED W/ZnCr GOLD		
1/4	8 N·m (71 lb in)	11 N·m (97 lb in)	12 N·m (106 lb in)	16 N·m (142 lb in)	8.5 N·m (75 lb in)	12.2 N·m (109 lb in)
5/16	17 N·m (150 lb in)	23 N·m (204 lb in)	24 N·m (212 lb in)	32 N·m (283 lb in)	17.5 N·m (155 lb in)	25 N·m (220 lb in)
3/8	30 N·m (22 lb ft)	40 N·m (30 lb ft)	43 N·m (31 lb ft)	57 N·m (42 lb ft)	31 N·m (23 lb ft)	44 N·m (33 lb ft)
7/16	48 N·m (36 lb ft)	65 N·m (48 lb ft)	68 N·m (50 lb ft)	91 N·m (67 lb ft)	50 N·m (37 lb ft)	71 N·m (53 lb ft)
1/2	74 N·m (54 lb ft)	98 N·m (73 lb ft)	104 N·m (77 lb ft)	139 N·m (103 lb ft)	76 N·m (56 lb ft)	108 N·m (80 lb ft)
9/16	107 N·m (79 lb ft)	142 N·m (105 lb ft)	150 N·m (111 lb ft)	201 N·m (148 lb ft)	111 N·m (82 lb ft)	156 N·m (115 lb ft)
5/8	147 N·m (108 lb ft)	196 N·m (145 lb ft)	208 N·m (153 lb ft)	277 N·m (204 lb ft)	153 N·m (113 lb ft)	215 N·m (159 lb ft)
3/4	261 N·m (193 lb ft)	348 N·m (257 lb ft)	369 N·m (272 lb ft)	491 N·m (362 lb ft)	271 N·m (200 lb ft)	383 N·m (282 lb ft)
7/8	420 N·m (310 lb ft)	561 N·m (413 lb ft)	594 N·m (438 lb ft)	791 N·m (584 lb ft)	437 N·m (323 lb ft)	617 N·m (455 lb ft)
1	630 N·m (465 lb ft)	841 N·m (620 lb ft)	890 N·m (656 lb ft)	1187 N·m (875 lb ft)	654 N·m (483 lb ft)	924 N·m (681 lb ft)

**NOTE:** For Imperial Units, 1/4 in and 5/16 in hardware torque specifications are shown in pound-inches. 3/8 in through 1 in hardware torque specifications are shown in pound-feet.

# Engine and crankcase - Functional diagram

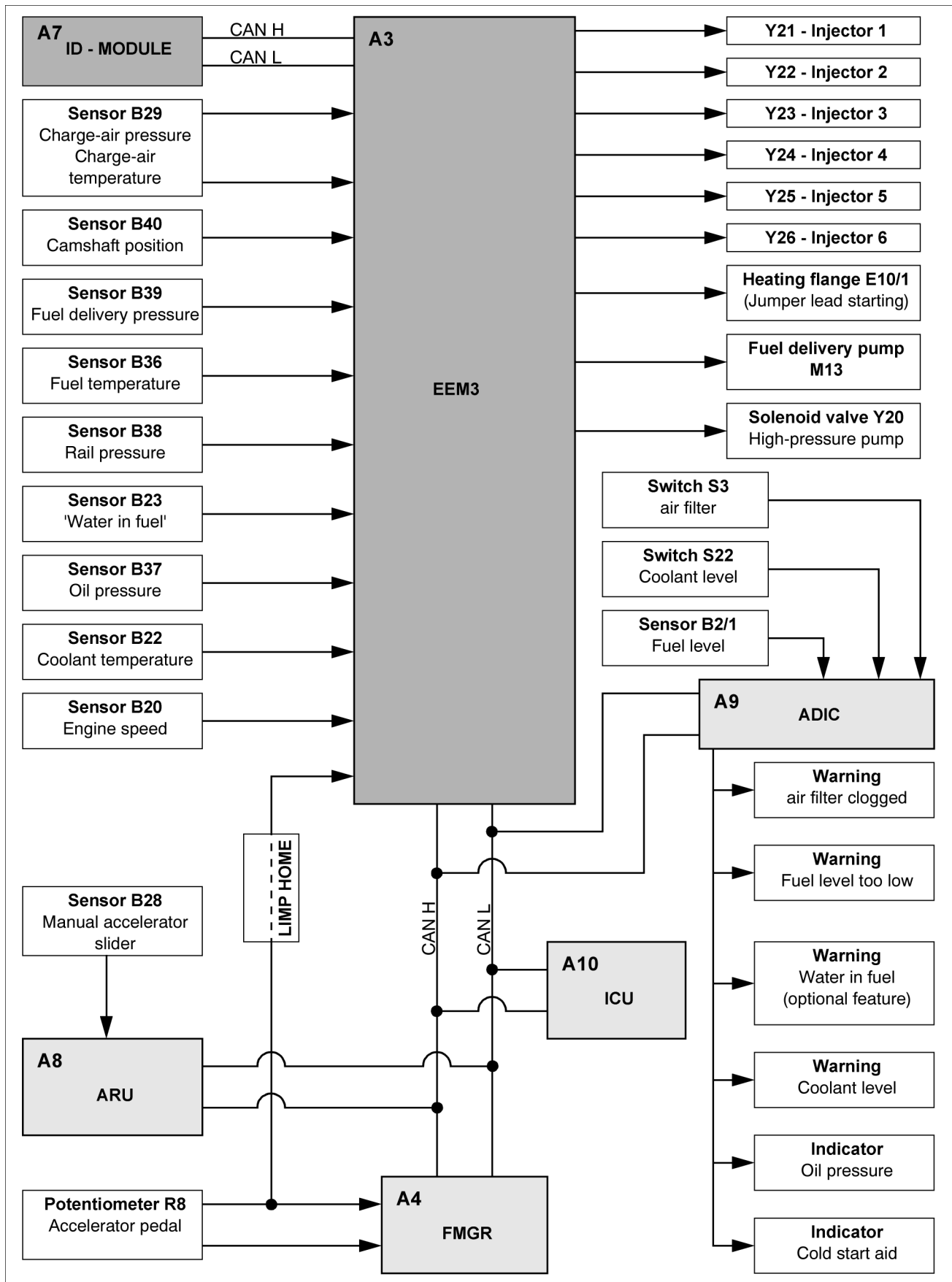

16. Press the plug in with the press-in tool **380000004**.

**NOTE:** Do not drive plug in too far because it may otherwise affect the camshaft's axial clearance.

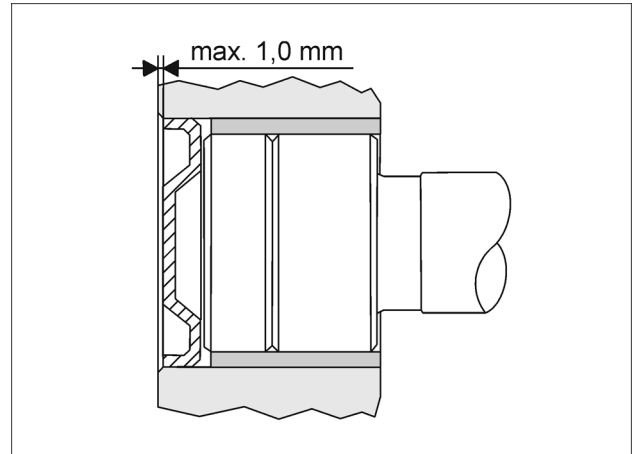

SS05N295 6

### Pressing in an oversize plug on the rear end of the camshaft after inserting an oversize bearing bush

The standard plug is replaced with an oversize plug with an O-ring seal after working the bore.

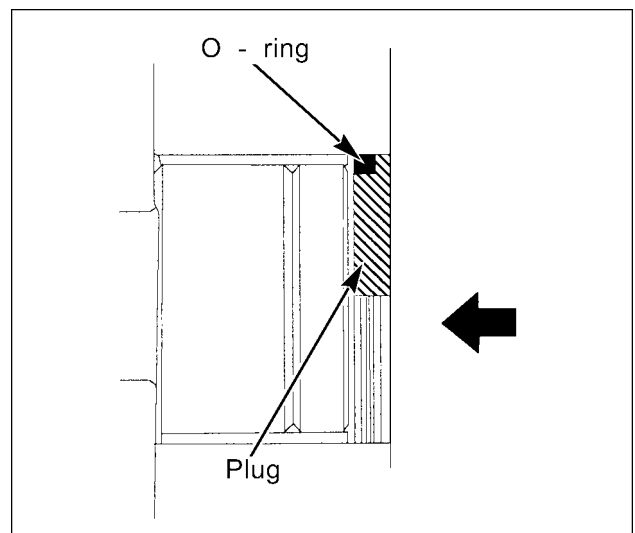

7

### Inserting the cylinder liner

17. Clean the cylinder liner and the liner recess in the cylinder block. The liner must turn freely without an O-ring in its installed position.
18. Apply a thin layer of marking colour on the bottom of the cylinder liner flange. Insert the cylinder liner without O-rings and turn in both directions. Pry out the cylinder liner and check whether the coating has deposited over the entire contact face.
19. Clean the contact surfaces.



## Checking the piston

Visually inspect the piston and piston bolt. Check in particular for possible cracks on the edge of the combustion chamber or the upper part of the piston bolt bore. Measure the piston diameter at the point shown in the diagram and compare the result with the specified value. Change the piston if necessary.

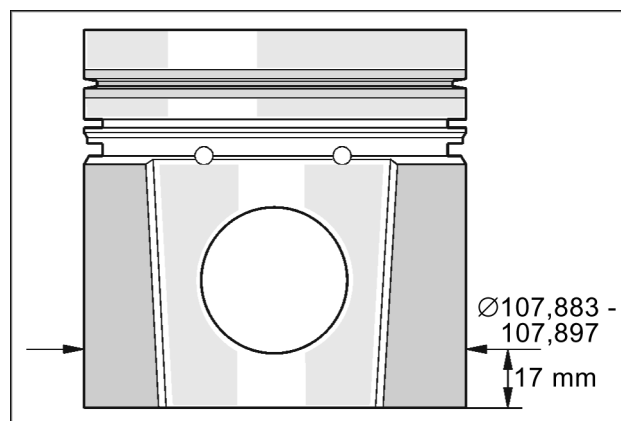

## Fitting the piston bolt

15. Insert connecting rod into piston and slide piston bolt into place.

**NOTE:** To fit the piston bolt warm the piston to **100 °C!**

**ATTENTION:** The combustion chamber in the piston and the letter for marking the connecting rod's weight class are on one side.

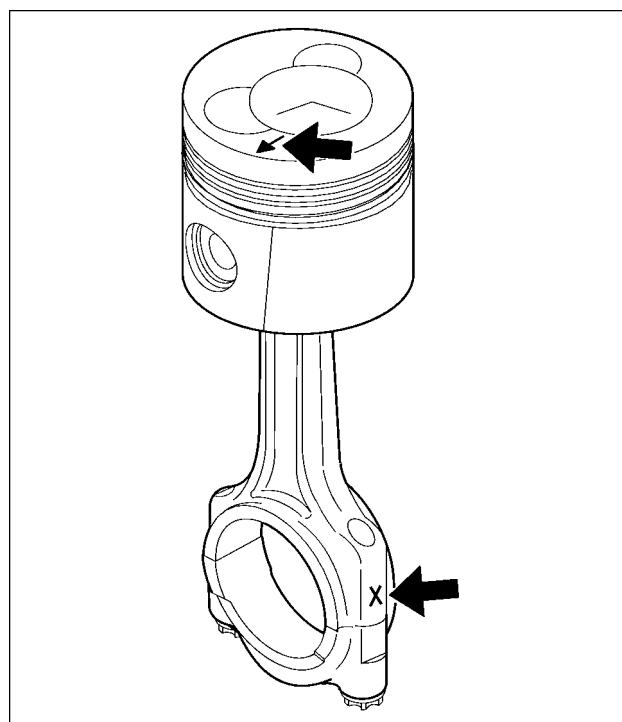

SS05N333 8

16. Then fit the piston bolt's circlips. The ends of the circlips must face upwards.

## Fitting the piston and connecting rods

17. Insert bearing cups into connecting rods. Ensure that the fitting surfaces are clean and that the bearing cups are fitted correctly.
18. Apply engine oil to piston, piston rings and cylinder. Rotate piston ring gaps on different sides of piston.

Transmission ratio of drive gears	4 : 3
Injection sequence	1-5-3-6-2-4

## Injectors

Type	CRIN 2 - 2V
Number of blowholes	5

## Fuel

pumped fuel quality	Standard EN 590
Fuel supply - temperature, max.	70° Celsius

## Fuel filter

Upstream filter	30 µ Stanadyne
Fine filter	5 µ Stanadyne
Delivery pump	electrical, fitted on upstream filter
Supply voltage	12 volt DC
Current max.	6 amps
Delivery pressure during engine idling, at least	0.75 bar

## Fuel specifications

Specification	Requirement	Test method
Density at <b>+15 °C</b>	<b>0,82...0,84 kg/dm<sup>3</sup></b>	EN ISO 3675:1998, EN ISO 12185
Viscosity at <b>+40 °C</b>	<b>2,0...4,5 mm<sup>2</sup>/s</b>	EN ISO 3104
Sulphur content	max. <b>350 mg/kg</b>	EN ISO 14596:1998
Cetane rating	at least 51	EN ISO 5165:1998
Water content	max. <b>200 mg/kg</b>	prEN ISO 12937:1996
Lubrication capacity	max. <b>460 µm</b>	ISO 12156-1

The diesel fuel used must satisfy the EN 590 standard.

**NOTE:** For operation in summer and winter, various different diesel fuels are required. Information about the winter fuel required for each location can be obtained from your local fuel dealer.

## Dependency of engine performance on fuel quality

Different physical parameters of the fuel quality, such as temperature, density and viscosity impact on the current engine performance.

The performance of the engines is specified at a density of **0,84 kg/dm<sup>3</sup>**, at a specific heat quantity of **42,7 MJ/kg** and a fuel temperature of **+15 °C**.

The diagrams provided below show the change in engine performance as a % when the physical parameter changes.

### Diagram A

Engine performance depends on fuel temperature. The reference temperature is **+35 °C** (correction factor **0 %**). The fuel temperature is not only a function of the ambient temperature but also varies depending on the fuel system, e.g. due to tank volume, tank position, volume returned, line and filter position and the material of the lines.

### Diagram B

The engine performance depends on the density of the fuel used. The standard value is **0,84 kg/dm<sup>3</sup>** at **+15 °C**.

### Diagram C

The engine performance depends on the viscosity of the fuel used. The standard value is 3 cSt at **+20 °C**.

## Turbocharger - Torque

Tightening torque of compressor housing bolts	13.60 Nm
Tightening torque of turbine housing bolts	21.00 Nm
Tightening torque of shaft nuts (compressor end)	13.60 Nm

**NOTE:** The technical data listed in the table above applies to all performance classes. There are however different spare part numbers for 175 and 195 hp engines since the turbine gears are different.

## Turbocharger - Service limits

### Schwitzer S200 turbocharger

Axial clearance of shaft	max. 0.10 mm
Radial clearance of shaft (compressor end)	max. 0.88 mm

**NOTE:** The technical data listed in the table above applies to all performance classes. There are however different spare part numbers for 175 and 195 hp engines since the turbine gears are different.

10. Use a new gasket to secure the rear plate. To fit the rear plate, use guide pins with a diameter of **8.5 mm** for the bores shown in the diagram.

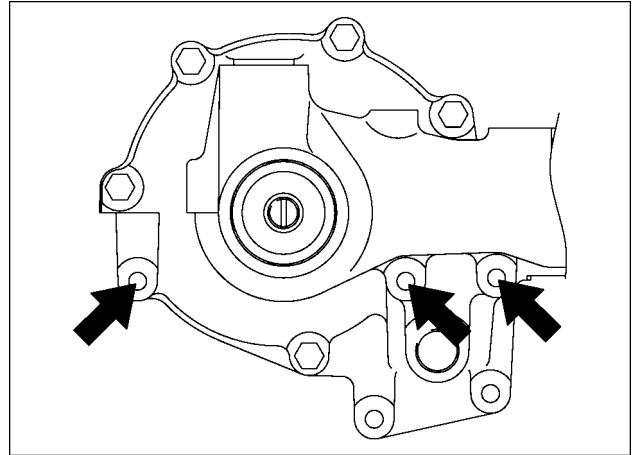

SS05N353 5

### Coolant quality requirements

- The coolant must satisfy the ASTM D 3306 or BS 6580:1992 quality standard.
- If there are no frost resistance requirements, a mixture ratio of **40 %** is enough to ensure sufficient corrosion protection.
- Check the coolant's mix ratio at certain intervals (frost protection). Change the coolant every two years.
- The water used must be clean and soft. In other words, it must not contain metals or any of their salts.

**NOTICE:** *Never use water on its own as a coolant.*



## Continuously Variable Transmission (CVT) - Install

### Prior operation:

### Continuously Variable Transmission (CVT) - Remove (21.504)

**NOTICE:** Before the cartridge is fitted, the inside of the gearbox housing must be cleaned carefully.

1. Pre-assemble a new collet (17) in the coupling sleeve (18). Slide the coupling sleeve onto the pinion shaft.

**NOTE:** Align the pinion shaft bores with the coupling sleeve!

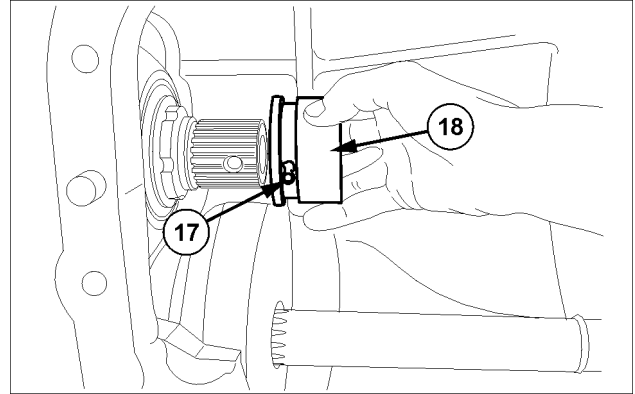

SS08C022 1

2. Insert sealing rings (16).

**NOTE:** Before inserting the cartridge, check the sensor wheels for damage.

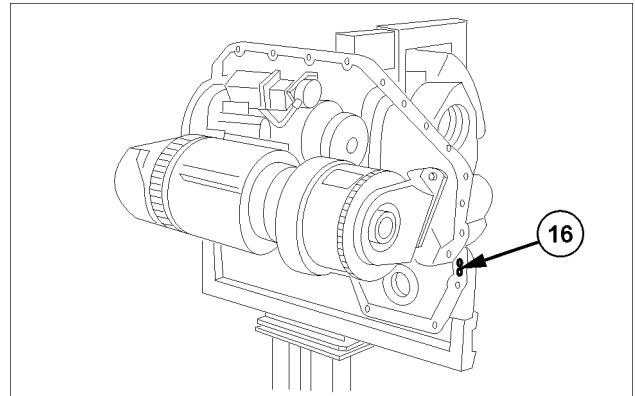

SS08C021 2

3. Install the dowels (2) into the gearbox housing. Apply **LOCTITE® 518** surface sealant evenly to the sealing surface.

**NOTE:** When applying the sealant, maintain sufficient clearance from the O-rings (16).

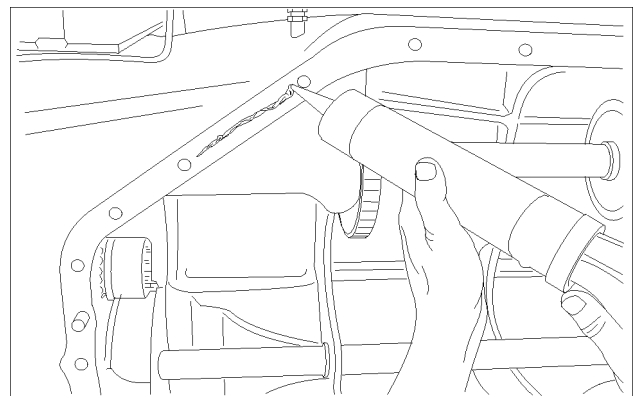

SS08C023 3

## Continuously Variable Transmission (CVT) external controls - Overview Transmission module (cartridge)

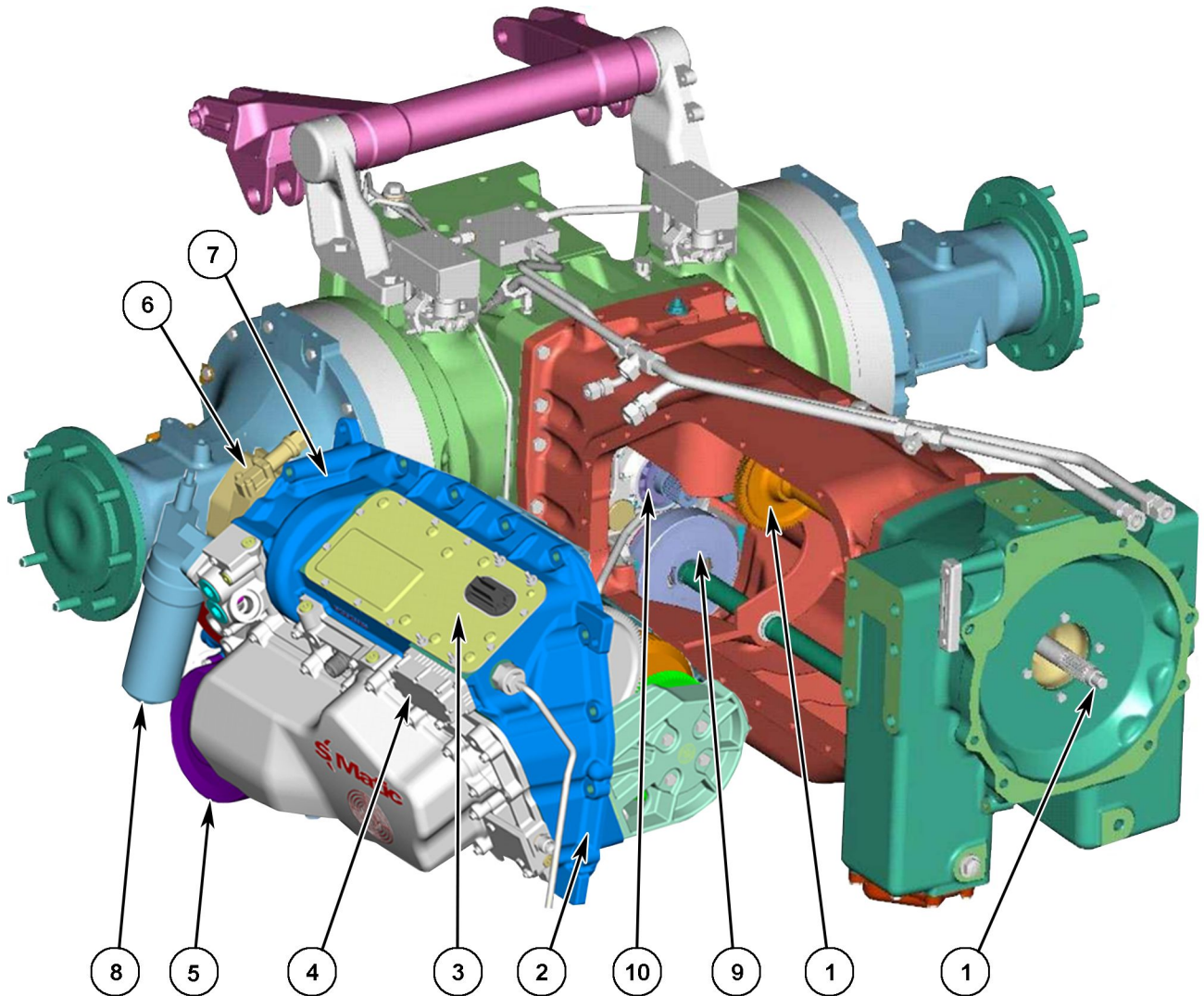

SS00M054 1

1. Input shaft (drive for the internal geared wheel 1, hydrostat, lubrication and system pressure pump, PFC pump and PTO shaft)
2. Transmission module
3. Transmission electronics (SGR)
4. Hydrostat electronics (Linde electronics box)
5. Suction filter lube pump / system pump 30 bar
6. System pressure pump 30 bar (vane cell pump)
7. Lube pump (rotary pump)
8. Pressure filter
9. MFD clutch
10. Pinion (output)

9. Disconnect the plug connection.

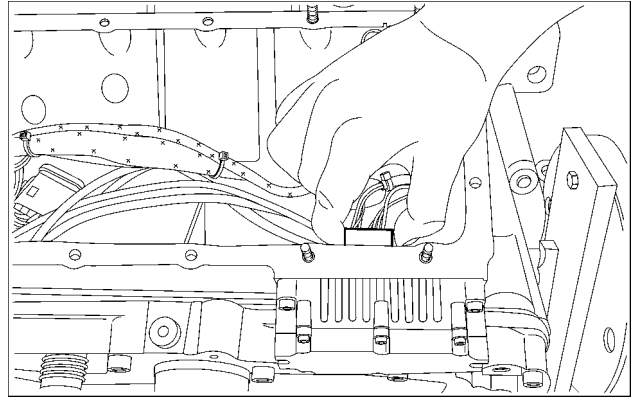

SS12C243 8

10. Undo the screws and remove the hydrostat controller.

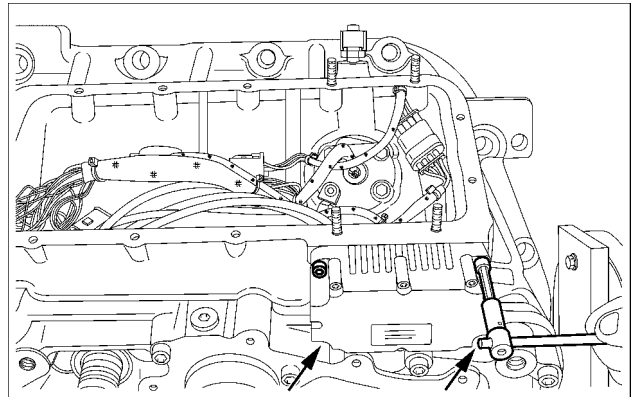

SS12C244 9

11. Mark all plug connections and disconnect from the solenoid valves.

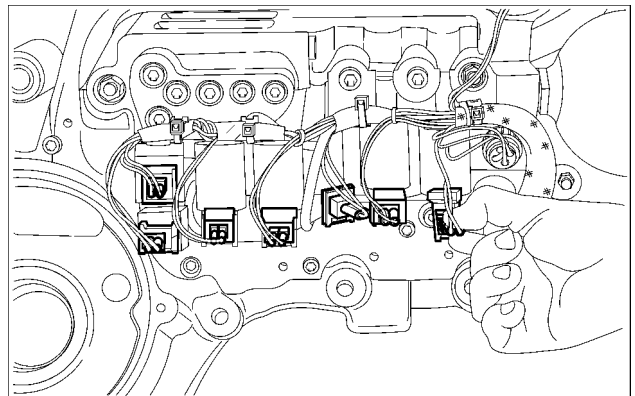

SS12C245 10

### Removing the parking lock valve

12. Undo the nut and pull the released coils out of the valve.

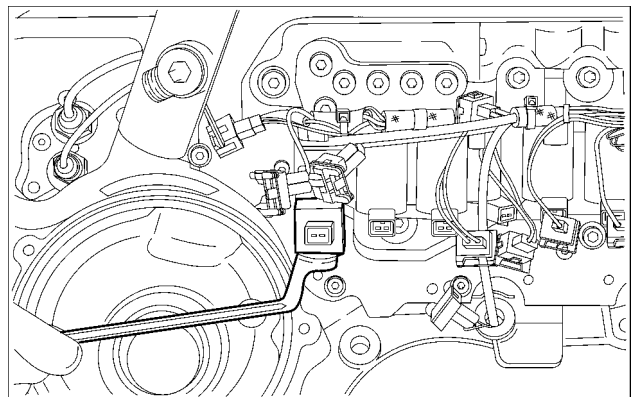

SS12C246 11

9. Undo the screws and remove the valve block, O-rings and rectangular rings.

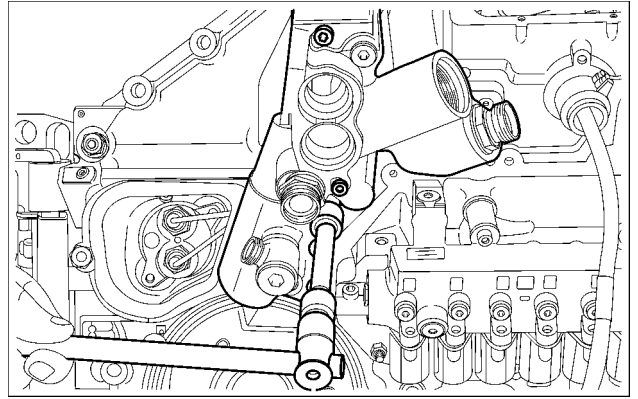

SS12C275 8

### Removing the valve block (4WD/parking lock)

10. Mark the three plug connections and disconnect them.

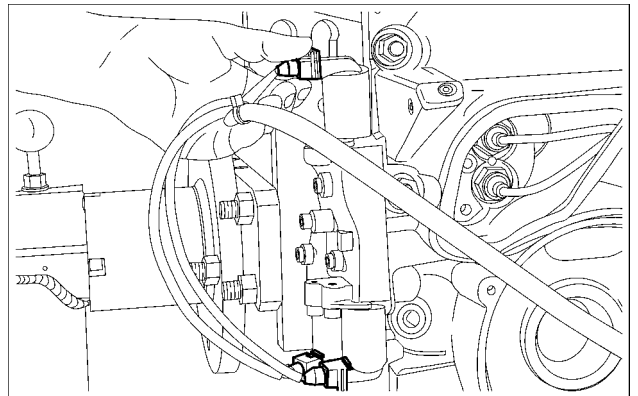

SS12C276 9

11. Undo the screw, remove the claw and pull the solenoid valve out of the hole.

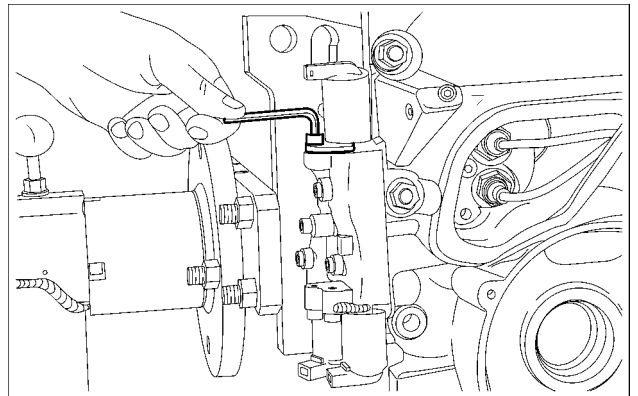

SS12C277 10

12. Undo the screw and the nuts. Then remove the valve block and the rectangular rings.

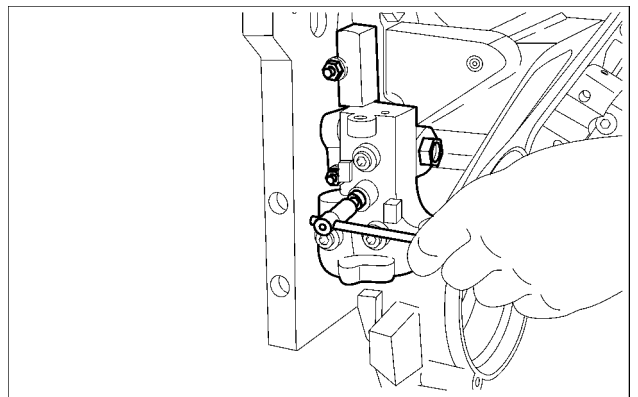

SS12C278 11

3. Remove the screw and pull out the claw with the solenoid valve from the valve block.

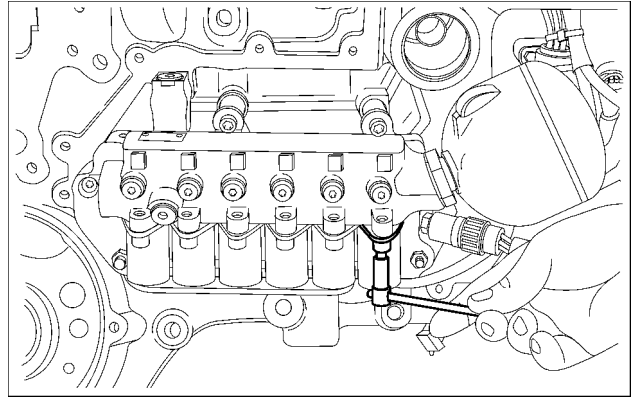

SS12C281 4

4. Insert the new solenoid valve and secure with the claw and the screw. Tighten the screw to **10 Nm (7.4 lb ft)** and connect the cables with the correct assignment.

**NOTE:** Check the sealing rings on the valve body and grease with industry Vaseline.

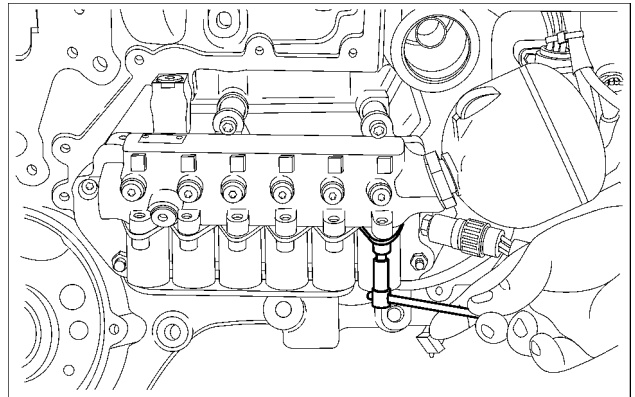

SS12C281 5



## **Transmission - 21**

### **Continuously Variable Transmission (CVT) internal components - 507**

**T7510  
T7520  
T7530  
T7540  
T7550**

## Gear and synchronizer Reverser - Dynamic description

### Forwards / Reverse

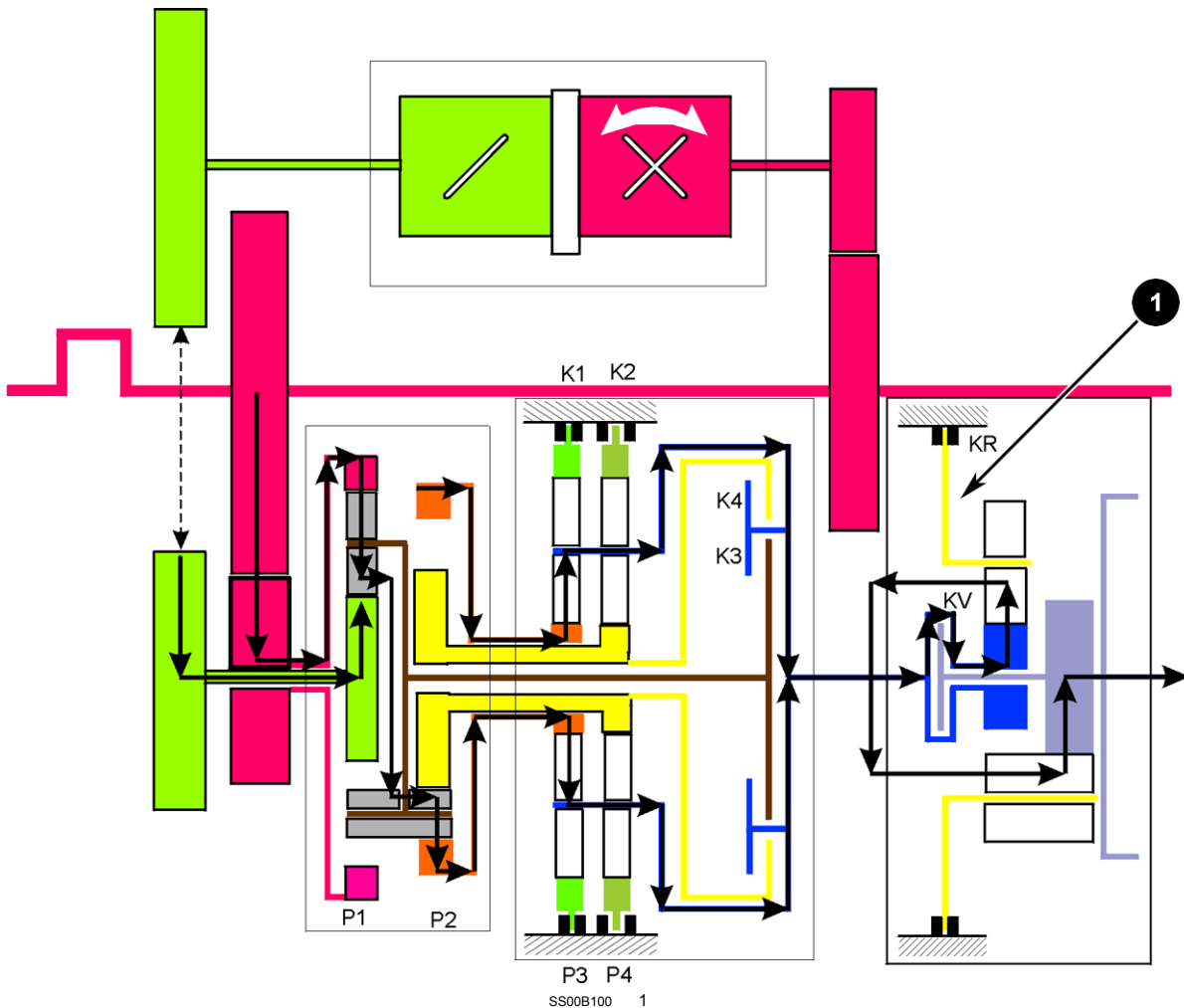

F/R transfer for planetary train:

Forwards  $i = 1.00$   
Reverse  $i = -1.11$

In the transmission there is a forwards/return planetary train downstream from the continuously variable range. When travelling forwards, the power flows directly between the output shaft of the continuously variable part and the gear output shaft via the claw clutch KV.

When travelling in reverse, closing the claw clutch KR connects the planetary carrier (1) to the housing, which causes it to turn in the opposite direction.

Due to overlapping shifting of the claw clutch KV (forwards) and the claw clutch KR (reverse) there is no interruption of torque in the driveline when shifting from the forwards to reverse direction of travel; in this way the driveline always remains friction-locked.

7. Insert the O-ring into the ring groove.

**NOTE:** Grease the O-ring with industrial Vaseline.

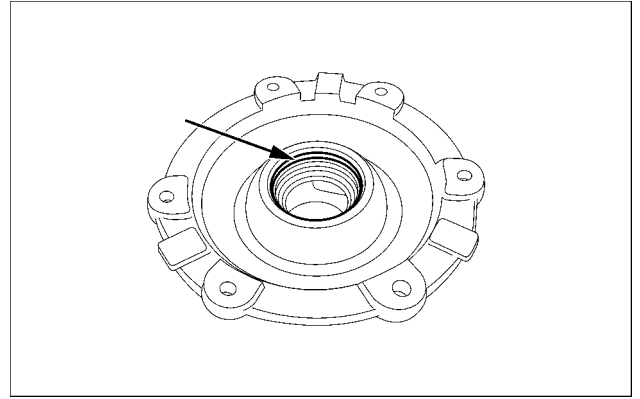

SS12E123 8

8. Insert the outer bearing ring (1) into the bearing bore until it sits in place.  
Insert the O ring (2) into the ring groove.

**NOTE:** Grease the O-ring with industrial Vaseline.

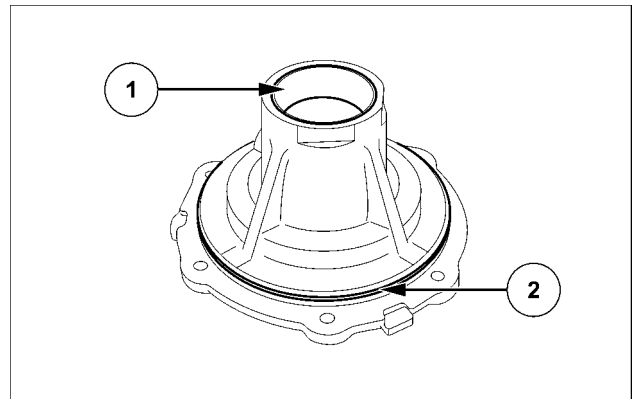

SS12E124 9

9. Fit the guide pins (M10) and thread on the adjusting screw(s) (e.g. 0.95 mm (0.037 in)).

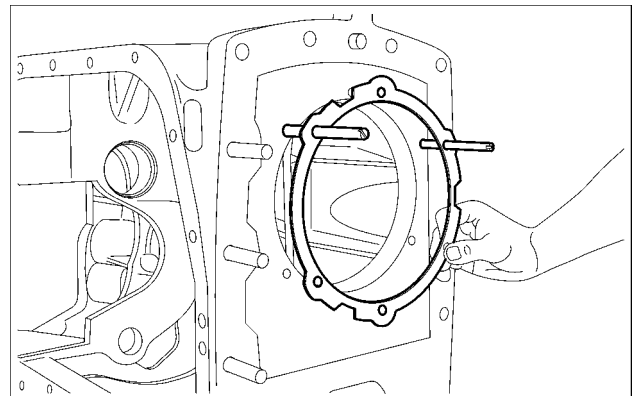

SS12E125 10

10. Insert the input shaft into the housing and fix with the bearing cap.

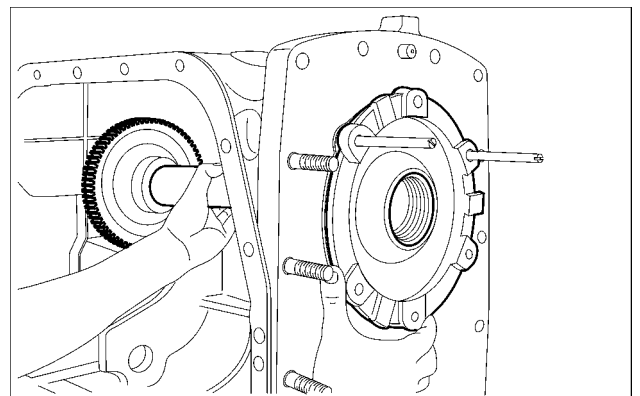

SS12E126 11

## Gear/Selector drum - Disassemble (K2 clutch)

### Gear/Selector drum - Exploded view (21.507)

#### Prior operation:

#### Gear/Selector drum - Disassemble (Clutch reverse) (21.507)

1. Loosen screws (66) and detach housing (65) from housing (56).

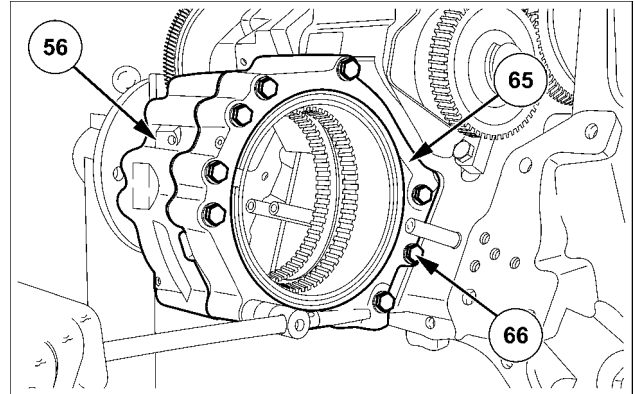

2. Force out (58) collet.

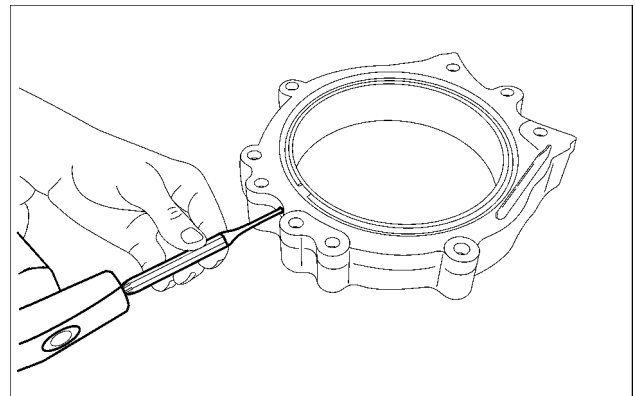

3. **⚠ WARNING**

**Spring under tension!**  
**Compressed springs have potentially dangerous stored energy. Always assemble and disassemble properly.**  
**Failure to comply could result in death or serious injury.**

W0356A

Preload the cup washers using special tool 380000420 and release circlip (64).

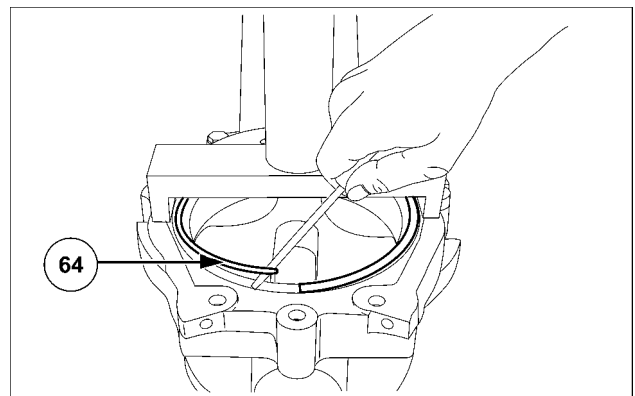

7. Thread the pre-assembled ring gear **(37)** onto the central shaft **(41)**.

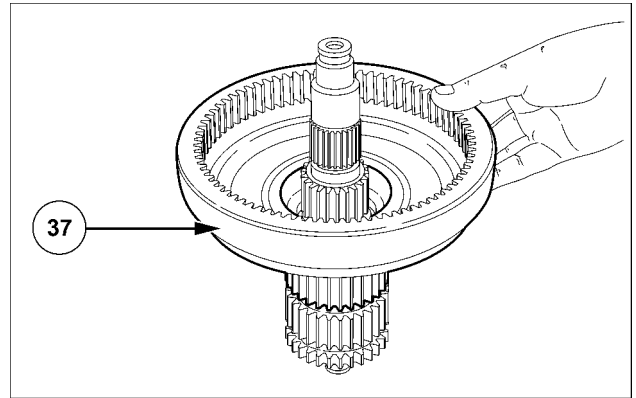

SS12C196 8

8. Insert the pre-assembled central shaft **(41)** into the clutch shaft **(90)** until it sits.

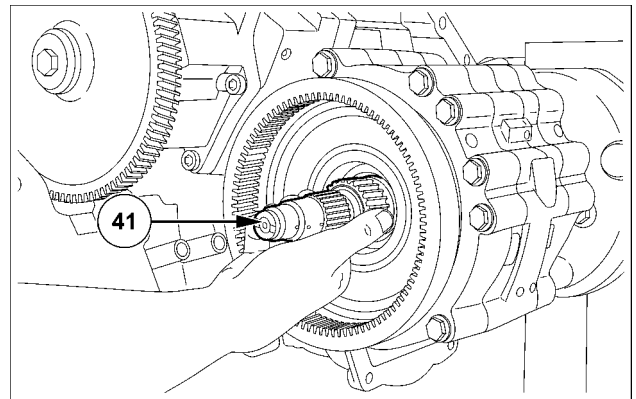

SS12C197 9

9. Fit sun gear **(35)**.

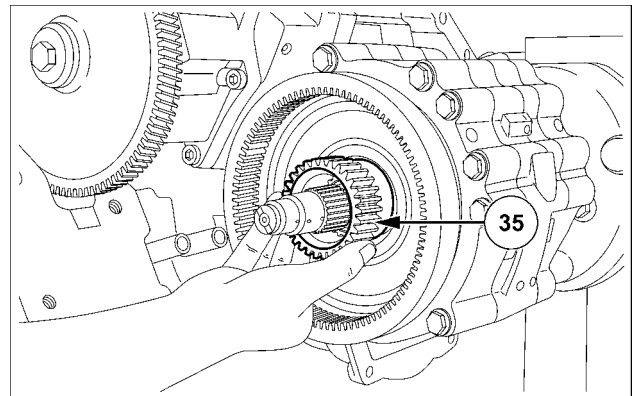

SS12C198 10

10. Pre-assemble the planet gears as shown in the diagram on the right.  
**(27)** and **(28)** Bearing bolts  
**(30)** Needle bearings  
**(31)** Spacer ring  
**(32)** Double planet gear  
**(33)** Planet gear

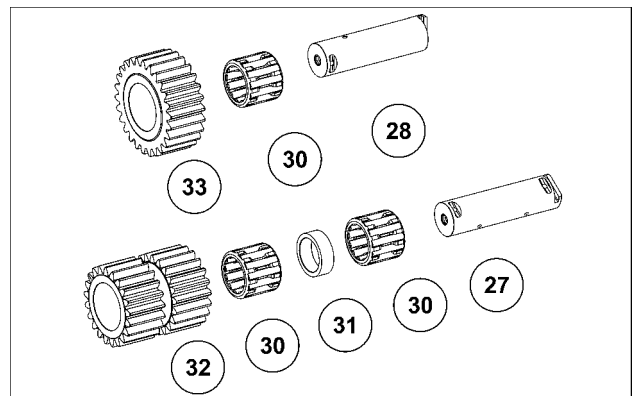

SS12C237 11



PRINTED IN FRANCE

© 2013 CNH GLOBAL N.V.

All rights reserved. No part of the text or illustrations of this publication may be reproduced.

NEW HOLLAND AGRICULTURE policy is one of continuous improvement and the right to change prices, specification or equipment at any time without notices is reserved.

All data given in this publication is subject to production variations. Dimensions and weight are approximate only and the illustrations do not necessarily show products in standard condition. For exact information about any particular product, please consult your NEW HOLLAND AGRICULTURE Dealer.

4. Release the circlip from its position.  
Then use the two-arm puller to push the clutch shaft fully out of the housing.

**NOTICE:** Secure the clutch shaft to prevent it from falling off.

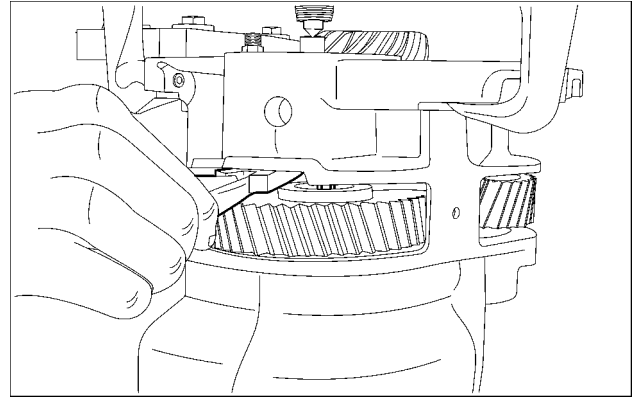

SS12D118 4

5. Remove the spur gear, circlip and taper roller bearing from the housing.

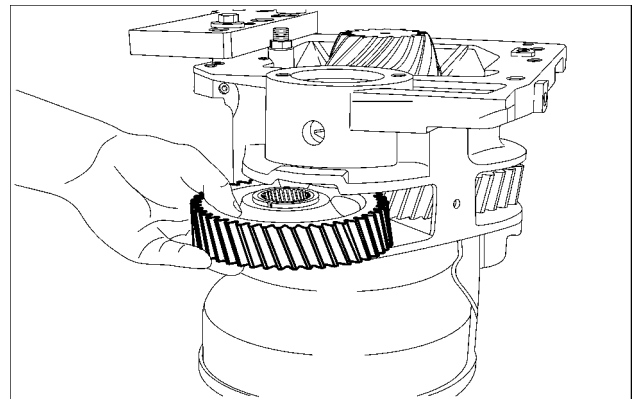

SS12D119 5

6. Release the circlip from its position.

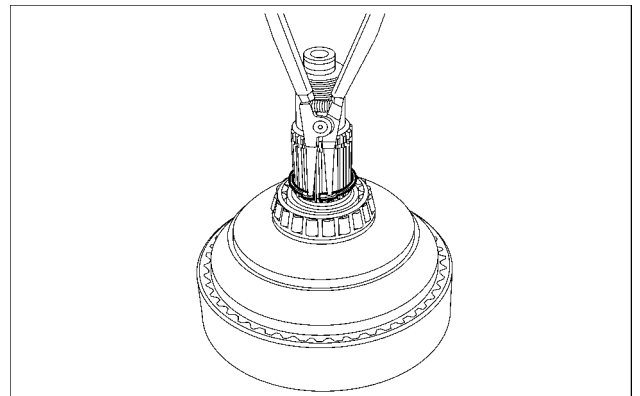

SS12E107 6

7. Remove the taper roller bearing from the clutch shaft using a standard puller.

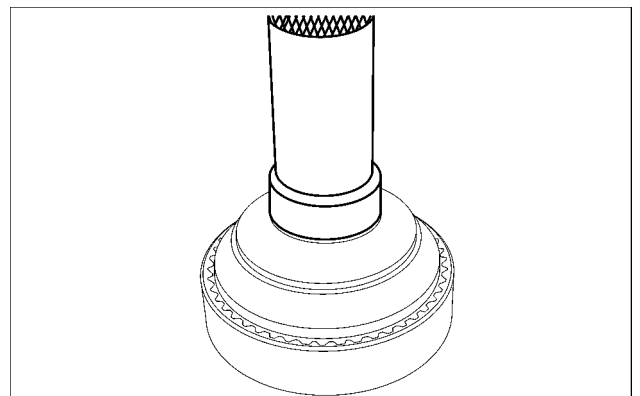

SS12E108 7

## Drive shaft - Install

### Prior operation:

Remove the 4WD shaft — see **Drive shaft - Remove (23.314)**.

**NOTE:** All components must be lubricated prior to installation.

1. Fit the shaft seal in the bearing cap with special tool **380000428**.

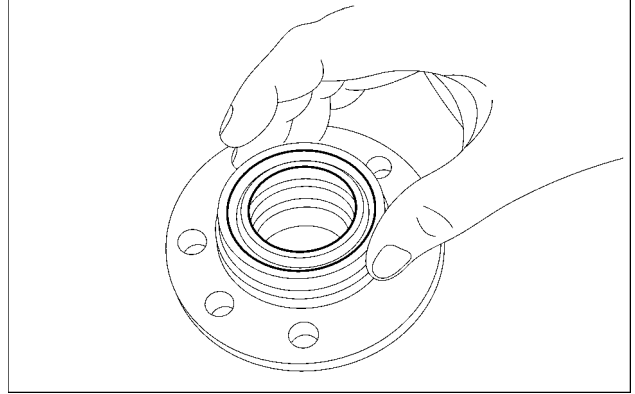

SS12E190 1

2. **CAUTION**

**Burn hazard!**  
Always wear heat-resistant protective gloves when handling heated parts.  
Failure to comply could result in minor or moderate injury.

C0047A

Fit circlip (1). Heat up bearing (2) to 80 °C (176 °F) and fit. Fit circlip (3).

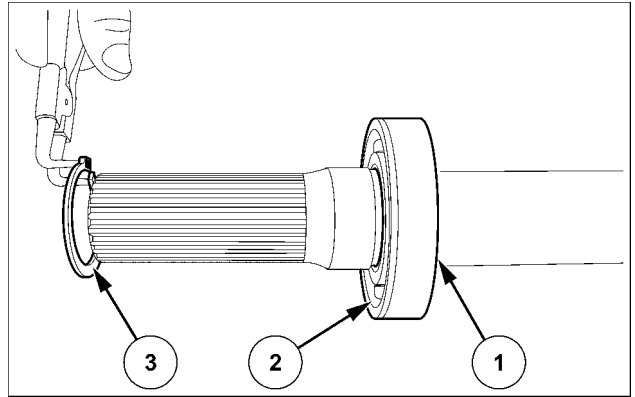

SS12E191 2

3. Insert the seal with the bearing into the cap. Insert circlip (S). Insert circlip (D) into cap.

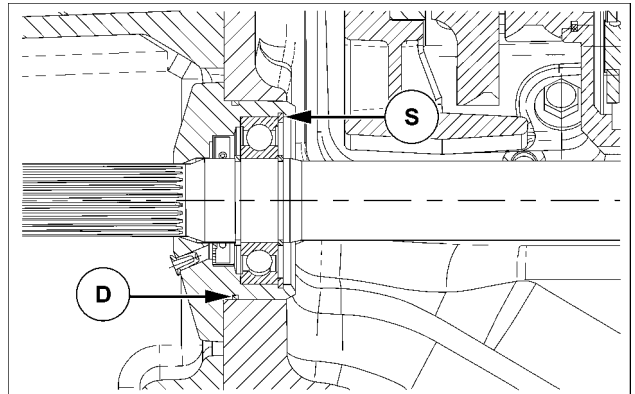

SS12E192 3

Front axle system - Powered front axle

Assembly sleeve for seal ring in steering knuckle

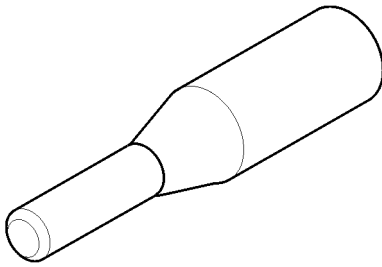

13

380000034

Half ring for seal ring in protective tube

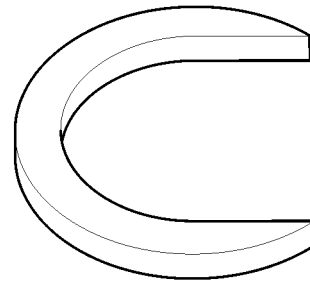

14

380000398

Drift for seal ring in protective tube

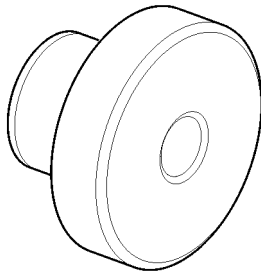

15

380000444

Wrench for castellated nut on bottom spring arm

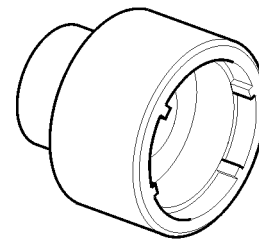

16

380000041

Drift for bush in top spring arm

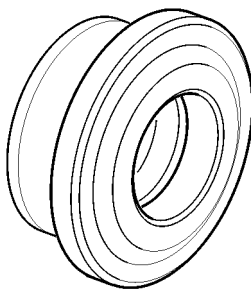

17

380000445

Drift for bush in bottom spring arm

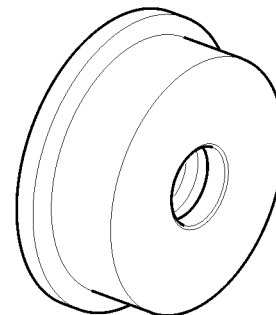

18

380000447

## Powered front axle - Remove and installing

T7540, T7550

### **WARNING**

**Before you do service under the machine, put the machine on a level surface, engage the parking brake and stop the engine. Put blocks at the front and rear of the tires. Failure to comply could result in death or serious injury.**

46-77A

The steps are numbered in the order needed for removal. To install, proceed in the same way as for removal but in reverse order.

Before the all-wheel drive front axle is removed from the tractor, the following must be done:

- Park the tractor on firm, level ground, apply the parking brake and use the RAISE/LOWER switch to lower the axle to the bottom stop. Shut off the engine and remove the starter key.
- Slide chucks in front of and behind the rear wheels.
- Disconnect the battery (the negative terminal first).

**NOTE:** When installing, connect up the positive (+) terminal(s) first.

**NOTE:** Only undertake steps 1 to 4 if the tractor is fitted with the front power lift (optional extra).

1. Remove brackets for outer hydraulic lines from support frame (left and right). Disconnect hydraulic hoses from the piping running in the support frame. Seal the hydraulic hoses.

**ATTENTION:** If the tractor is fitted with a free return, running to the front, it is essential that this line is sealed. If this line is not sealed, the hydraulic oil will escape!

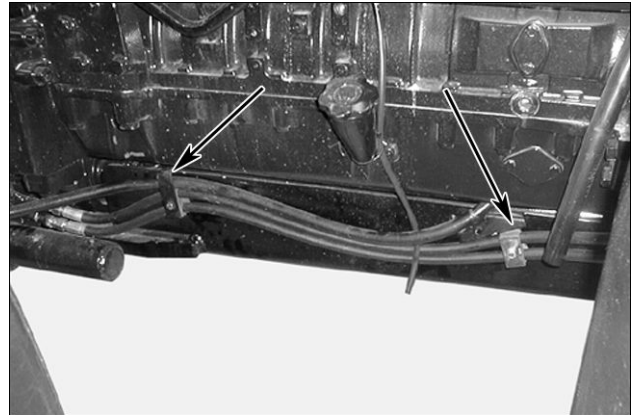

SD00B017 1

2. Place a hydraulic jack under the support frame and remove rear retaining bolts.

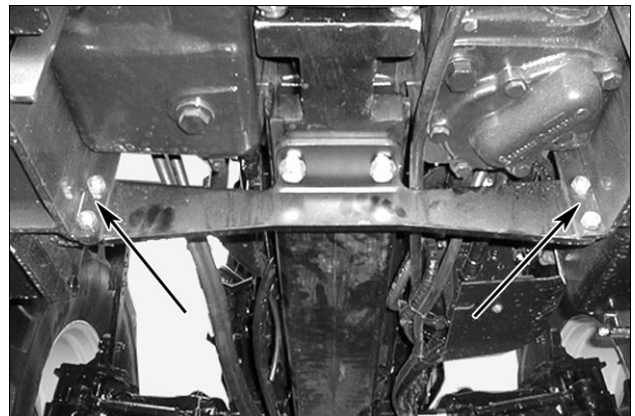

SD00B018 2

## Torsion bar - Install

T7540, T7550

1. Fit new O-ring (31) on front flange (32) using grease.

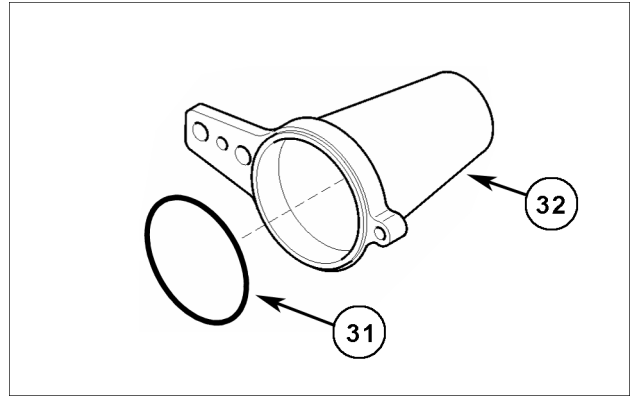

SS06K028 1

2. Position the front flange on the bottom spring arm and insert with a soft hammer.

**NOTE:** Do not damage the O-ring (31) or the O-ring item 166 (see Exploded view **Steering knuckle housing and steering articulation hub Frame arm - Remove (25.108)**).

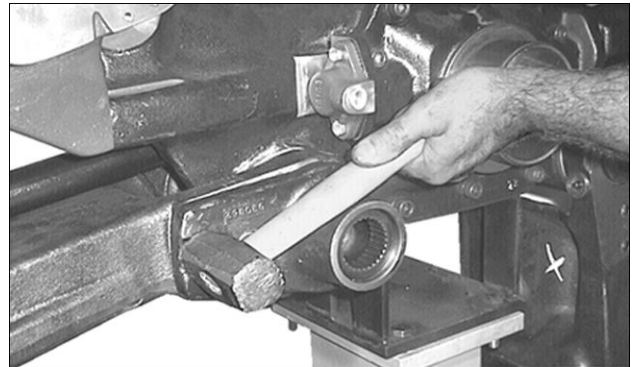

SD01M110 2

3. Use a suitable drift to drive centring bushes (36) into front flange.

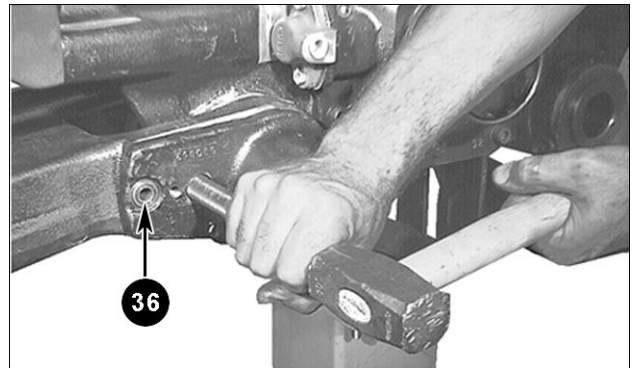

SD01M111 3

4. Insert and tighten the screws (33) and (37) of the front flange.  
Tightening torque **95 Nm**

**NOTE:** Note length of screws! Lock screws with Loctite 542.



SD01M112 4

## Bevel gear set and differential carrier - Disassemble

T7510 Vorderachse 20.25S, T7520 Vorderachse 20.25S, T7530 Vorderachse 20.25S

### Prior operation:

#### - Powered front axle - Remove (25.100)

**NOTE:** The parts are numbered in the order in which they are disassembled. During assembly, the position of the pinion shaft must be set accurately, see **Bevel gear set and differential carrier - Assemble (25.102) - "Pinion shaft setting"**

1. Unscrew retaining bolts (1) and remove front housing cover (2).

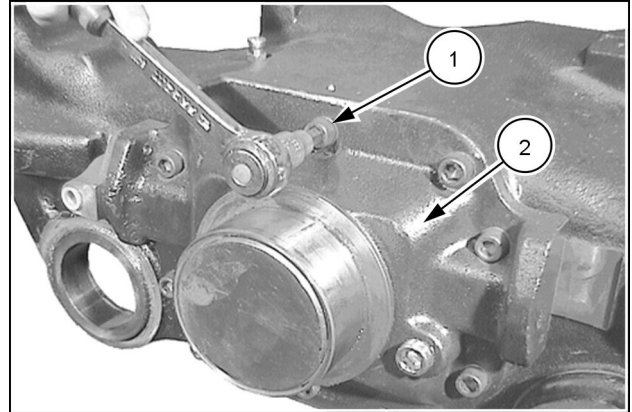

SD00B002 1

2. Unscrew retaining bolts (3) and remove cylinder (4) of differential lock actuation unit.

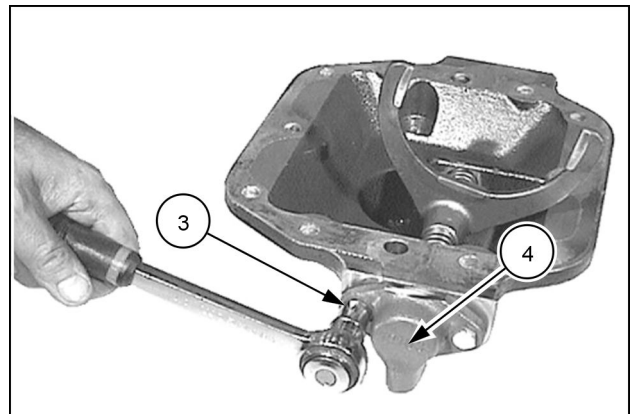

SD00B003 2

- |                     |                    |
|---------------------|--------------------|
| 221. Bush           | 222. Differential  |
| 223. Bearing        | 225. O-ring        |
| 226. Backup ring    | 229. Adjusting nut |
| 230. Retainer, left | 231. Washer        |
| 232. Seal ring      | 233. Ring          |
| 234. Washer         |                    |

## Axle shaft - Remove

T7540, T7550

### Prior operation:

- Planetary drive and hub - Disassemble (25.108)
- Front brake and disk - Disassemble (33.204) — where fitted
- Torsion bar - Remove (25.100)
- Steering knuckle and king pin - Remove (25.108)

1. Move the lower spring arm (64) downwards. Swivel the hydraulic cylinder upwards.

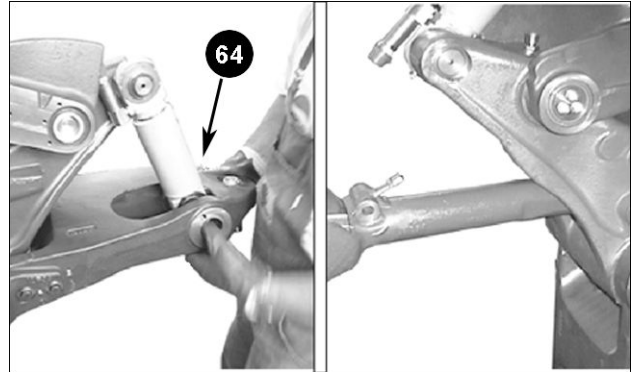

SD01M067 1

2. Pull the outer drive shaft out of the protection tube (106).

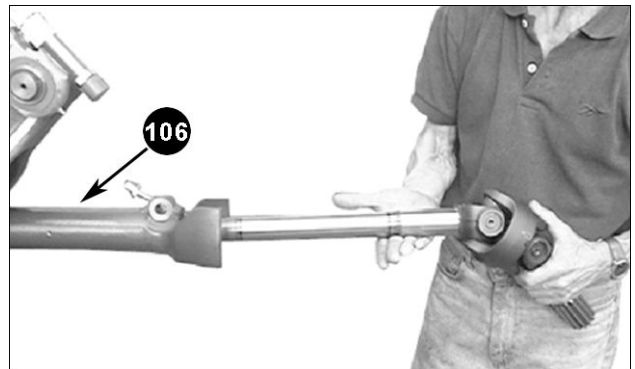

SD01M068 2

3. Take both sealing rings (110) and the bearing (109) out of the protection tube.

**NOTE:** Inspect the sealing rings and the bearing. Always replace the sealing rings.

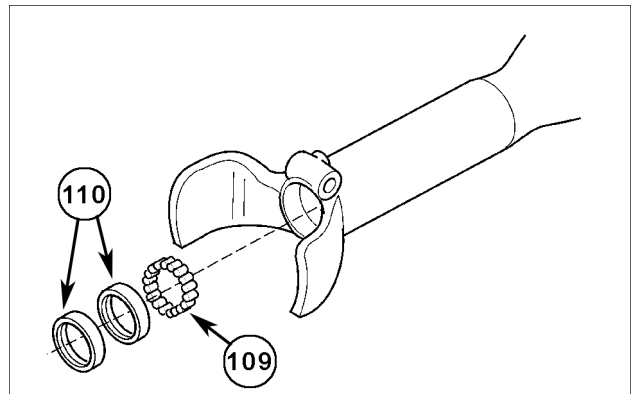

SS01M021 3

## Steering knuckle housing and steering articulation hub Frame arm - Remove

T7540, T7550

### Prior operation:

- **Suspended axle sensor Suspension position sensor - Remove (55.045)**
- **Torsion bar - Remove (25.100)**
- Remove the planet gear unit — see **Planetary drive and hub - Disassemble (25.108)**
- Disassemble the thrust plate and brake disc, if fitted — see **Front brake and disk - Disassemble (33.204)**
- Remove the lower bolts from the hydraulic cylinder — see **Axle suspension cylinder - Remove (25.122)**
- **Steering knuckle and king pin - Remove (25.108)**

**NOTICE:** If only the upper spring arm is removed, it is only necessary to remove the sensor. The other steps outlined above are not necessary. As preliminary work, steps 2–4 and step 8 from the chapter entitled **Steering knuckle and king pin - Remove (25.108)** must be carried out.

### Removing the upper spring arm

1. Undo the counter nut. Unscrew the fixing screw of the bolt (176) on the upper spring arm. Unscrew the mounting bolts from the cover (153).
2. Remove the cover (151) with the O-ring (152) as well as the thrust washer (150).
3. Secure the spring arm using lifting equipment. Force out the bolt (132) using a soft mandrel.

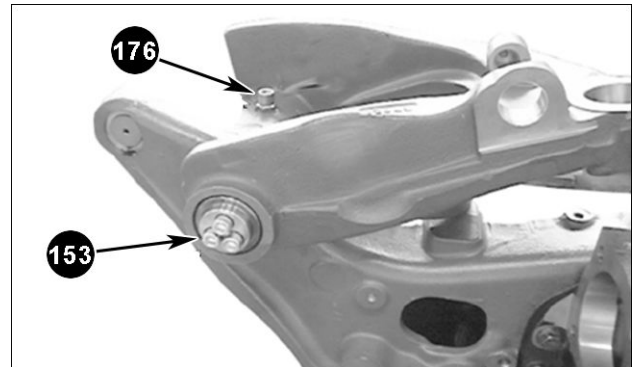

SD01M076 1

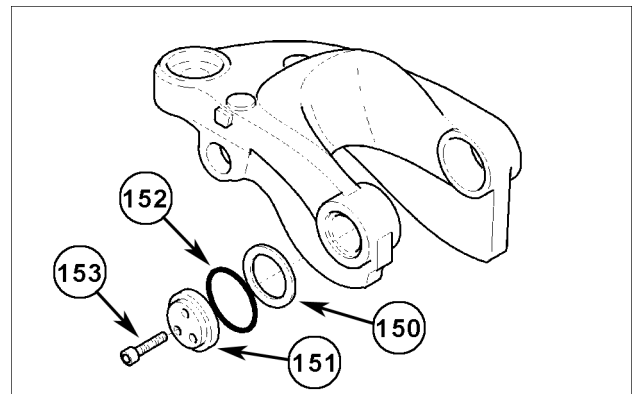

SS03D066 2

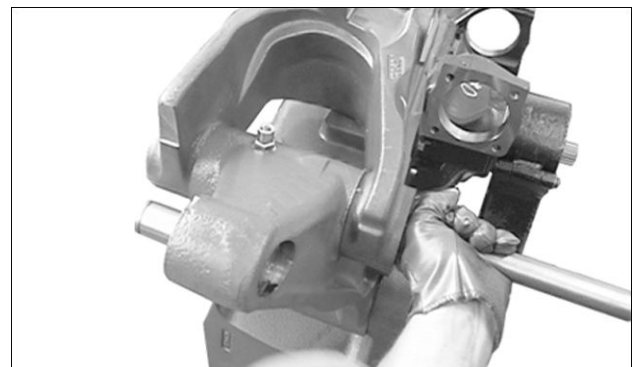

SD01M077 3

10. Fit rubber washer (4). Ensure that the nose (B) of the rubber washer protrudes into the bolt and that the "OUT SIDE" mark is facing outwards.

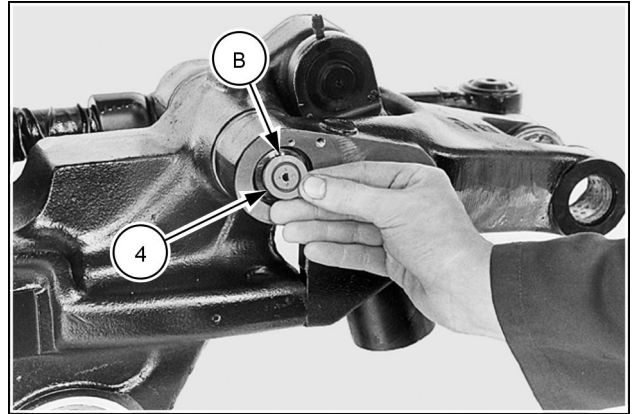

DP99F109 10

11. Fit washer (3) and potentiometer (2). Ensure that the flat side of the potentiometer shaft sits correctly in the rubber washer and that the mark on the potentiometer is in line with the spring arm.

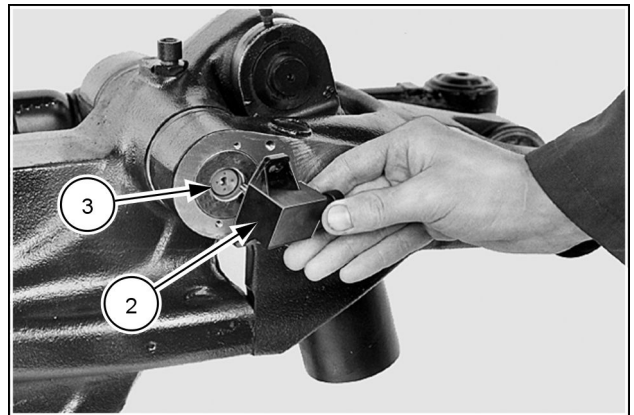

DP99F111 11

12. Fit retaining bolts (1) and tighten to 3 Nm.

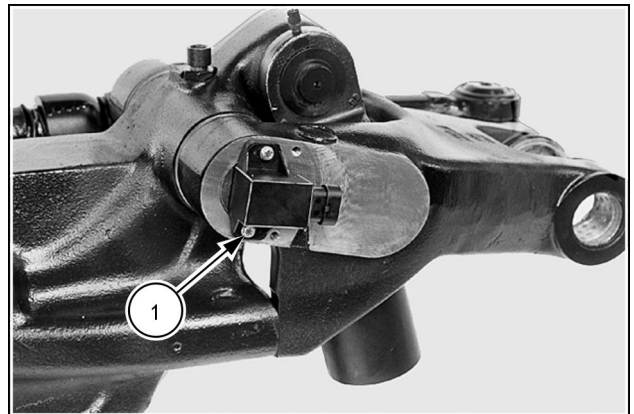

DP99F112 12

13. Insert new O-rings (see **Steering knuckle and king pin - Remove (25.108)** item.36) in the lower retainer of the spring arm. Insert new seal rings (see **Steering knuckle and king pin - Remove (25.108)** item.37) and ensure that sealing lips are facing spring arm.

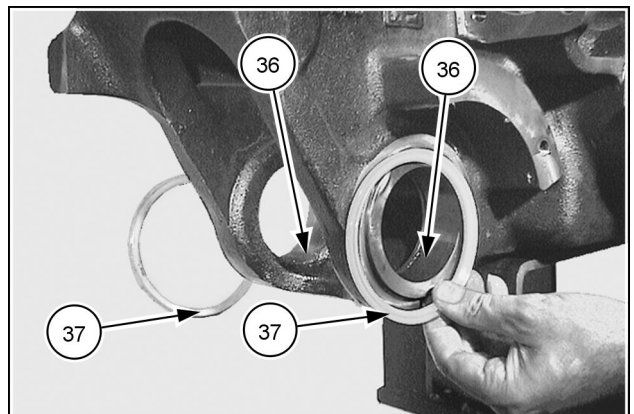

DK99D067 13

18. Screw centring bush (85) into fork bracket.  
Tightening specification:
- Tighten centring bush to 50 Nm.
  - Loosen centring bush and tighten to 30 Nm.
  - Tighten nut (84) to 250 Nm.

**NOTICE:** When tightening the nut (84), centring bush (85) must not also turn. Put a mark on the centring bush for checking purposes.

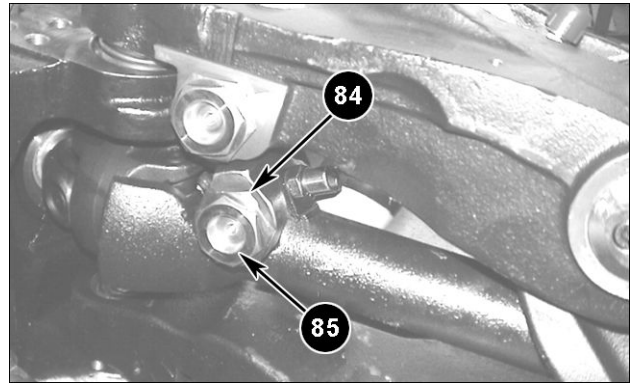

SD06K003 17

19. Screw lubrication nipple (40) into centring bush.

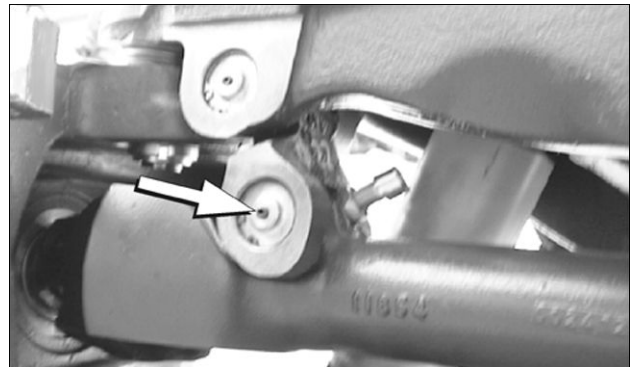

SD01M108 18

20. Tighten fixing screw (107) to secure bearing bolt (46) in fork bracket.

**NOTE:** Secure fixing bolt with Loctite 542.  
Tightening torque 135 Nm  
Tighten lock nut (108) for fixing screw.  
Tightening torque 70 Nm

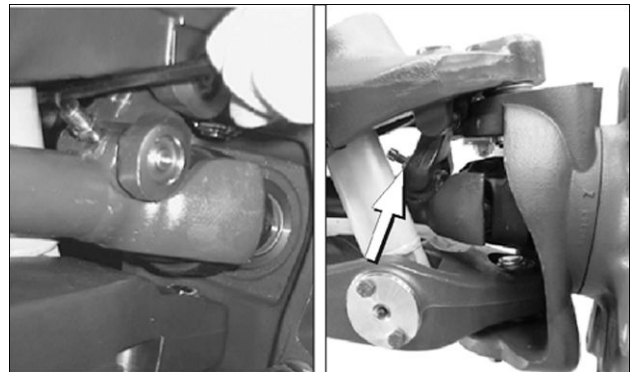

SD01M109 19

# Contents

---

## Front axle system - 25

### Axle suspension control - 122

#### TECHNICAL DATA

##### Axle suspension control

Special tools .....	3
T7510 Vorderachse 20.25S, T7520 Vorderachse 20.25S, T7530 Vorderachse 20.25S, T7540, T7550	

#### FUNCTIONAL DATA

##### Axle suspension control

Overview (20.25S) .....	5
T7510 Vorderachse 20.25S, T7520 Vorderachse 20.25S, T7530 Vorderachse 20.25S	

Overview (20.29S) .....	6
T7540, T7550	

Static description .....	7
T7510 Vorderachse 20.25S, T7520 Vorderachse 20.25S, T7530 Vorderachse 20.25S, T7540, T7550	

Dynamic description [→Z9Sx03020] .....	8
T7510 Vorderachse 20.25S, T7520 Vorderachse 20.25S, T7530 Vorderachse 20.25S, T7540, T7550	

Dynamic description [Z9Sx03021→] .....	10
--	----

##### Suspended axle control valve

Overview (solenoid valves) .....	15
T7510 Vorderachse 20.25S, T7520 Vorderachse 20.25S, T7530 Vorderachse 20.25S, T7540, T7550	

#### SERVICE

##### Axle suspension control

Axle suspension control - Service instruction Manually lower front axle .....	16
T7510 Vorderachse 20.25S, T7520 Vorderachse 20.25S, T7530 Vorderachse 20.25S, T7540, T7550	

Axle suspension control - Calibrate [→Z9Sx03020] .....	17
--	----

Axle suspension control - Calibrate [Z9Sx03021→] .....	18
--	----

##### Axle suspension cylinder

Remove .....	20
T7540, T7550	

Install .....	22
T7540, T7550	

##### Suspended axle control valve

Electrical test .....	24
-----------------------	----

5. Pull hydraulic cylinder off top bolt and remove underlying spacer **(75)**.  
Check all parts of cylinder fastening, including bearing bolts, replace if necessary. Check cylinder for leaks and ease of movement. Check condition of piston surface.

**NOTE:** A set of seals is needed for the hydraulic cylinder.

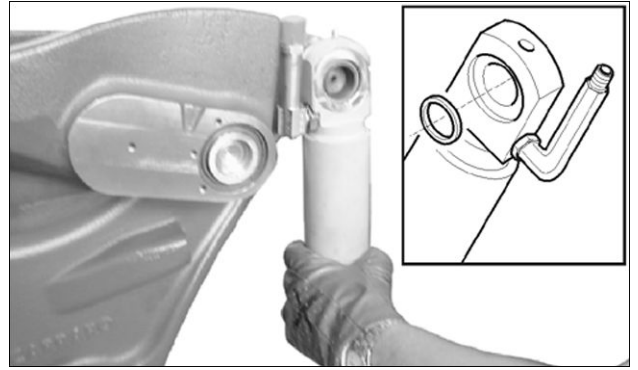

SD01M075 5

# Index

---

## Rear axle system - 27

### Powered rear axle - 100

Rear axle - General specification .....	3
Rear axle - Install .....	11
Rear axle - Remove .....	7
Rear axle - Service instruction .....	6
Rear axle - Special tools .....	4
Rear axle - Static description .....	5

8. Install the pre-assembled pinion.

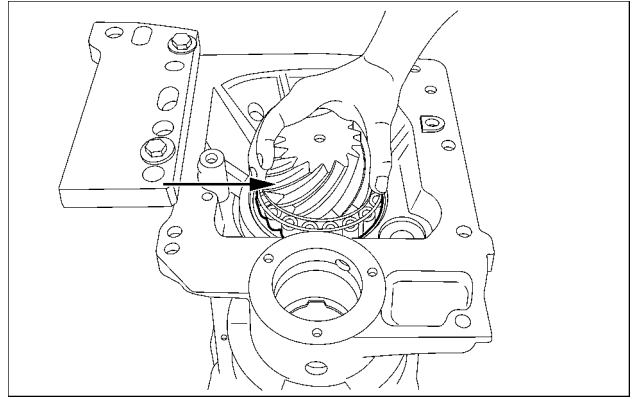

SS12E140 7

9. Secure the pinion and swivel the housing **180 °**.

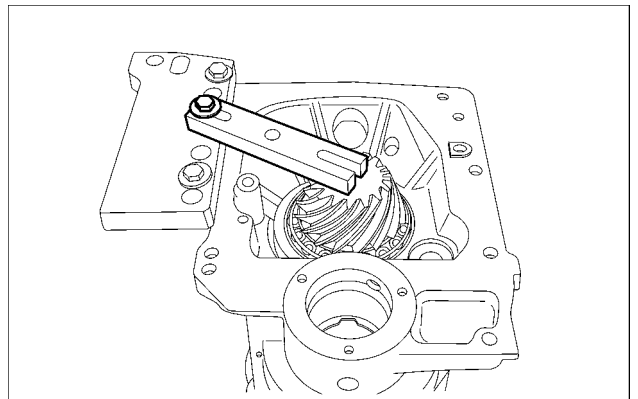

SS12E141 8

10. Fit the circlip.

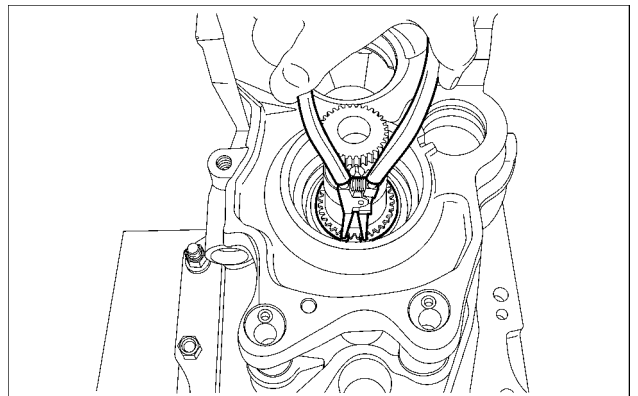

SS12E142 9

11. **CAUTION**

**Burn hazard!**  
**Always wear heat-resistant protective gloves when handling heated parts.**  
**Failure to comply could result in minor or moderate injury.**

C0047A

Insert the outer bearing ring into the housing bore until it sits in place.  
Then heat the taper roller bearing and thread it onto the pinion until it sits in place.

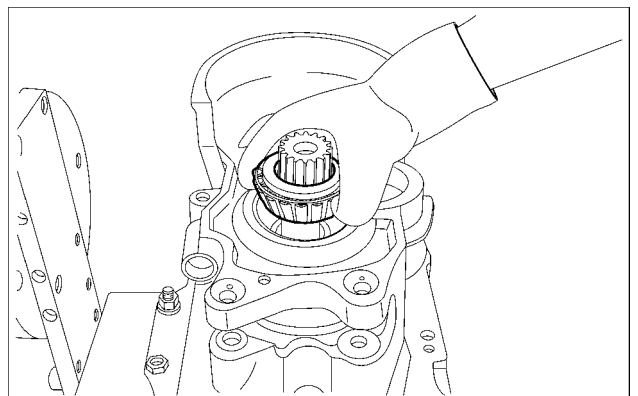

SS12E143 10

8. If necessary, drive the two outer bearing rings out of the axle trumpet housing.

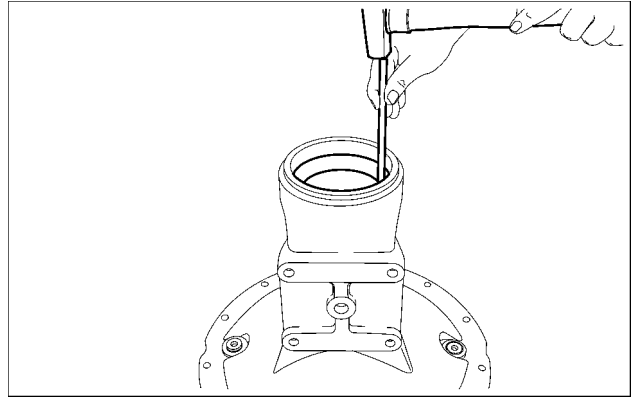

SS12E376 8

9. Remove the taper roller bearing from the rear axle shaft.

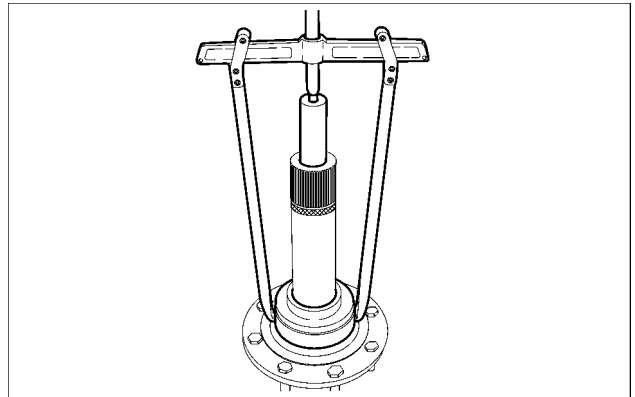

SS12E377 9

10. Remove the shaft sealing ring.

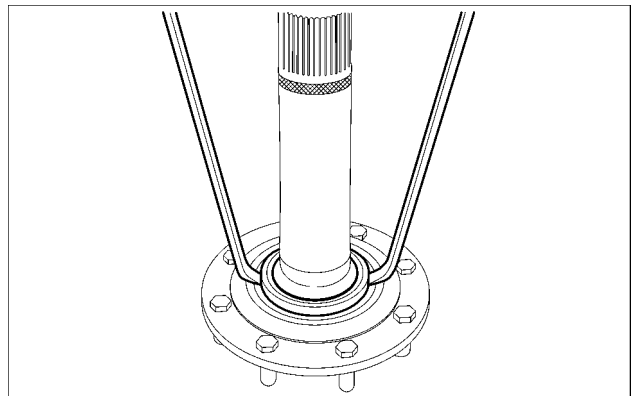

SS12E378 10

**NOTE:** Clean the components, check carefully for wear and damage, and replace if necessary.



## **Power Take-Off (PTO) - 31**

### **Four-speed rear Power Take-Off (PTO) - 119**

**T7510  
T7520  
T7530  
T7540  
T7550**

34. Set the bearing clearance of the second double spur gear bearing within the range **0.01 - 0.05 mm (0.000394 - 0.001969 in)** by rotating the grooved nut.  
Rotate the groove nut with the groove nut wrench **380000078**.  
Then secure the groove nut.

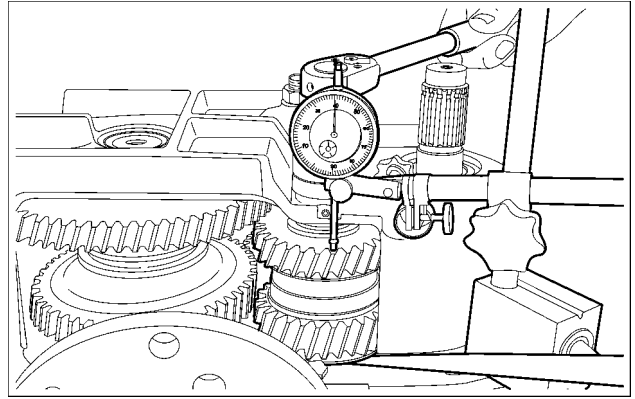

SS12E437 34

35. Insert the thrust springs and the balls into the bores of the disc holder.

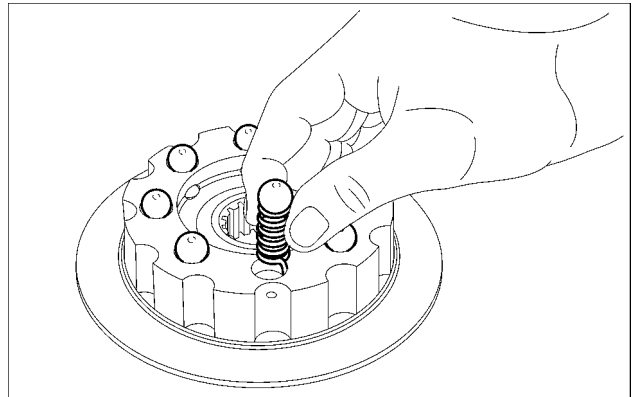

SS12E438 35

36. Fit the spring washer.

**NOTE:** Fit the individual parts of the disc set in turn (in accordance with diagrams 36 to 38) on the disc holder.

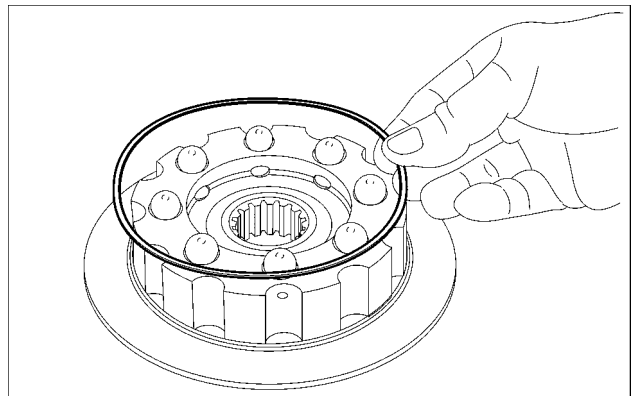

SS12E439 36

37. Position the outer disc over the spring washer.

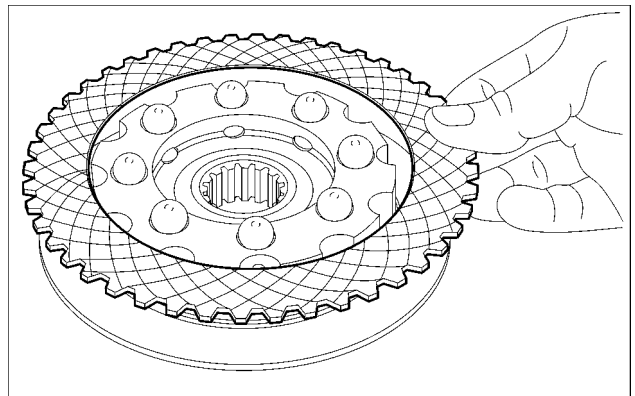

SS12E440 37

## Front Power Take-Off (PTO) - External view

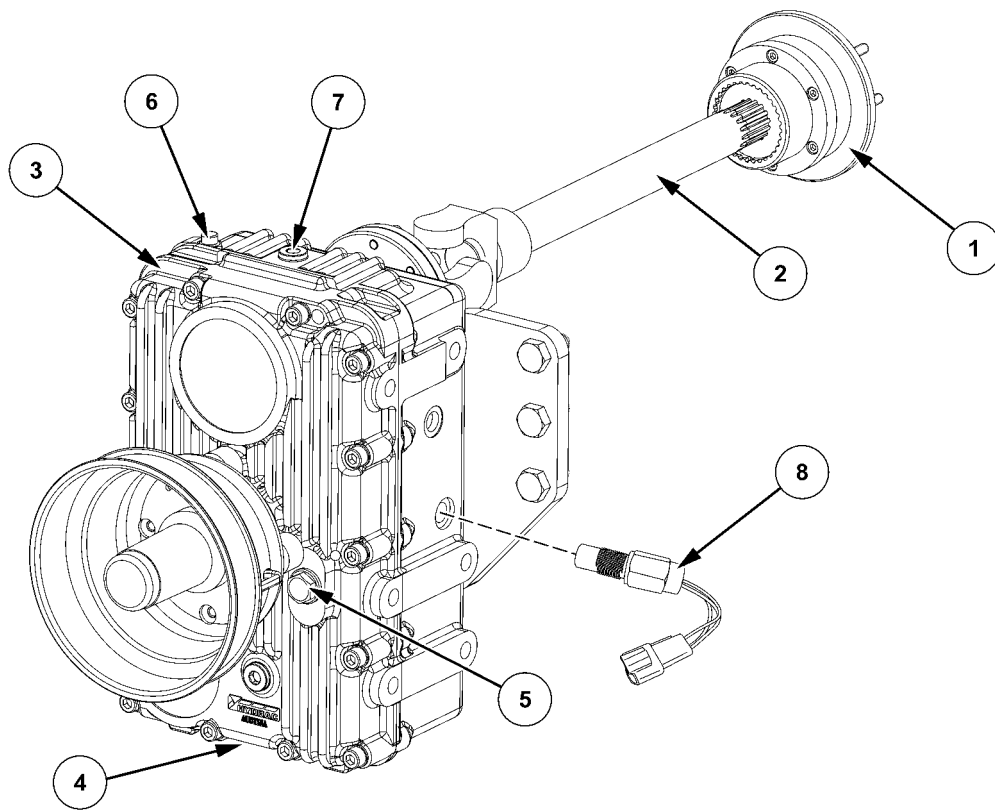

SS12B075 1

- |    |                            |    |                        |
|----|----------------------------|----|------------------------|
| 1. | Flange (on the crankshaft) | 2. | Drive shaft            |
| 3. | Front PTO gearbox          | 4. | Oil outlet screw       |
| 5. | Oil level indicator        | 6. | Gearbox ventilation    |
| 7. | Oil filler screw           | 8. | Front PTO speed sensor |

4. Remove release springs (48), all outer discs (15) and all inner discs (14).

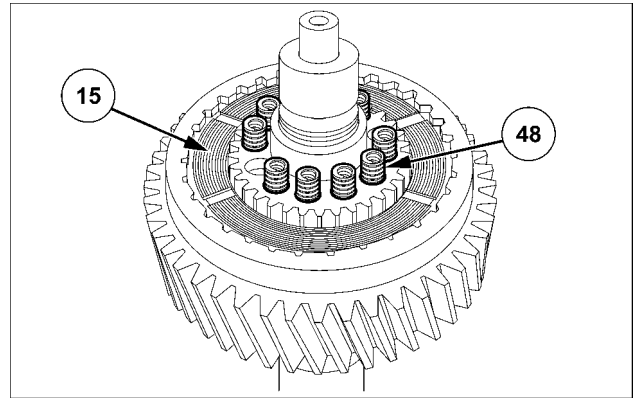

SS12A201 4

5. Remove inner bearing ring (18) and circlips (34) and (32) from shaft (5). Remove ball bearing (16) and spur gear (4).

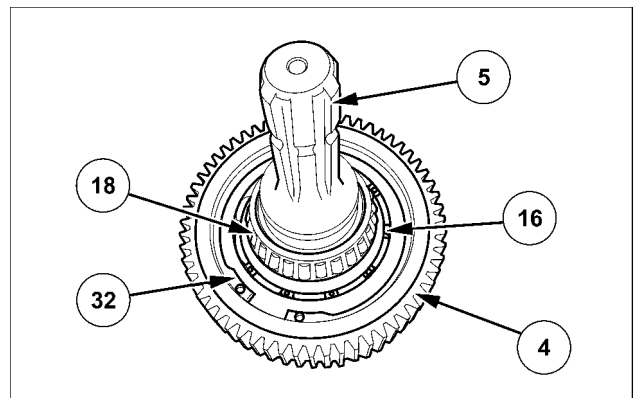

SS12A204 5

6. Take piston (7) out of cylinder (6) and remove sealing ring (26) and (27).

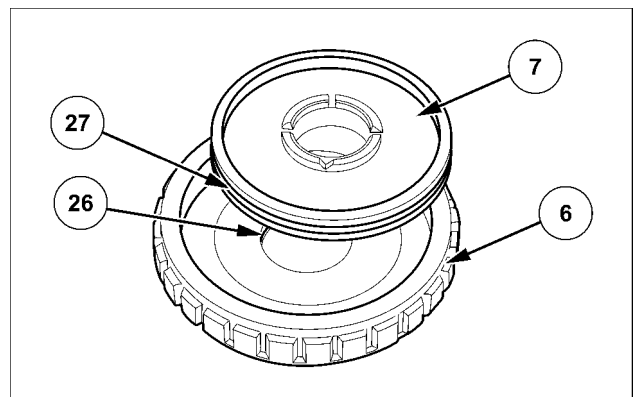

SS12A203 6

**NOTE:** Clean the components, check carefully for wear and damage and replace if necessary.

**Next operation:**  
Front Power Take-Off (PTO) clutch - Assemble (31.146)

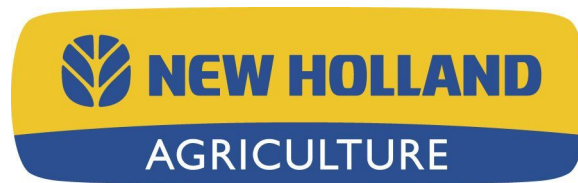

## **Brakes and controls - 33**

### **Parking brake or parking lock - 110**

**T7510  
T7520  
T7530  
T7540  
T7550**



7. Insert springs (14) and bushes (15) in ring gear carrier. Fit thrust plate (5) to ring gear carrier using retaining bolts (18) and washers (17).

Tightening torque **10 Nm**

Insert three remaining bushes (25) in holes with clamping sleeves (24). Insert retaining bolts (22) with washers (23) and tighten.

Tightening torque **10 Nm**

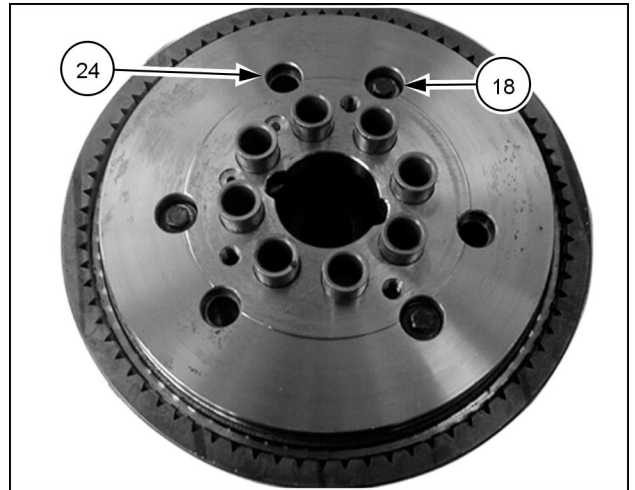

SD06M016 7

8. Apply grease to new O-rings (20) and insert in ring gear carrier.

**NOTICE:** Only use genuine O-rings.

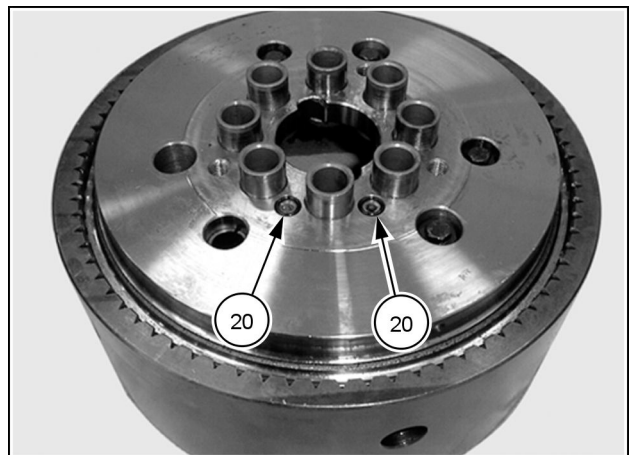

SD06M004 8

9. Fit ring gear carrier on steering knuckle housing and use two screws to screw down to the bushes protruding on the inside.

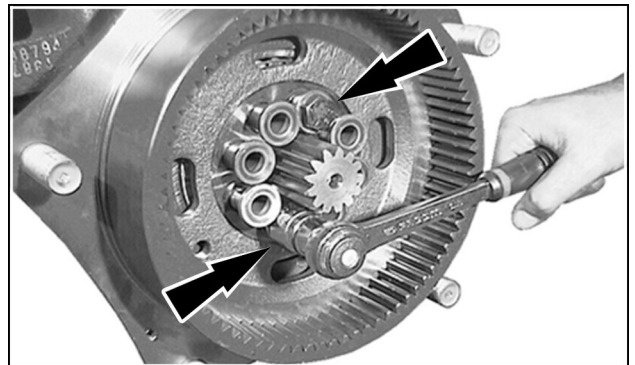

SD06M018 9

10. Use an appropriate drift to drive in all other centring bushes. Then screw in and tighten all bolts. Tightening torque **220 Nm**

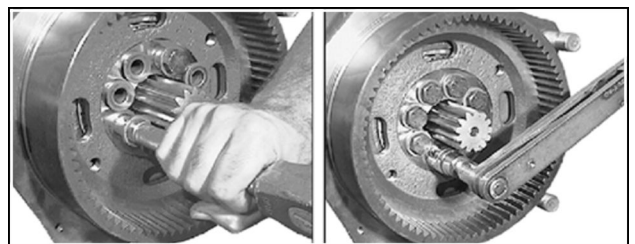

SD06M019 10



PRINTED IN FRANCE

© 2013 CNH GLOBAL N.V.

All rights reserved. No part of the text or illustrations of this publication may be reproduced.

NEW HOLLAND AGRICULTURE policy is one of continuous improvement and the right to change prices, specification or equipment at any time without notices is reserved.

All data given in this publication is subject to production variations. Dimensions and weight are approximate only and the illustrations do not necessarily show products in standard condition. For exact information about any particular product, please consult your NEW HOLLAND AGRICULTURE Dealer.

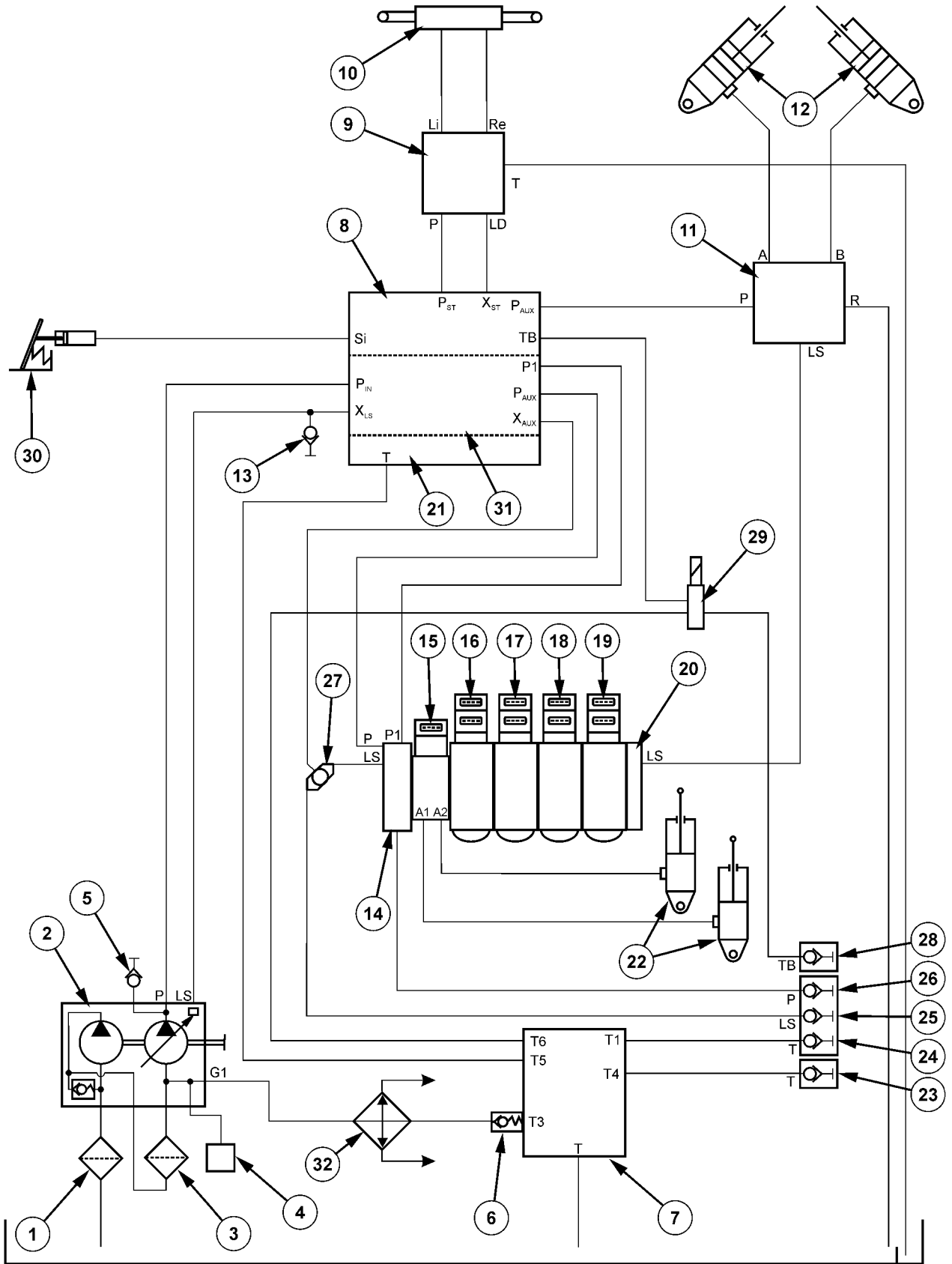



## Multi-function block valves Priority valve - General specification

### Standard priority valve - LT 41 HA

Priority 1	Steering
Priority 2	P1 Pilot pressure for auxiliary control units (AUX)
Priority 3	AUX - Auxiliary control units, EDC control valve and Power Beyond
P1 Pilot pressure auxiliary control units (AUX)	18+2 bar

### Priority valve with hydraulic trailer brake - LT 43 HP

Priority 1	Steering
Priority 2	Trailer brake
Priority 3	P1 Pilot pressure for auxiliary control units (AUX)
Priority 4	AUX Auxiliary control units, EDC control valve and Power Beyond
Transmission, hydraulic	1:11.1. Piston diameter D = 20 mm, d = 6 mm
P1 Pilot pressure auxiliary control units (AUX)	18+2 bar
Brake pressure, trailer brake	max. 150 bar
Spring for max. brake pressure	Spring length 28.1 mm, spring Ø 20.5 mm, wire Ø 3.8 mm

### Italian priority valve with hydraulic trailer brake - LT 43 HP G

Priority 1	Steering
Priority 2	Trailer brake
Priority 3	P1 Pilot pressure for auxiliary control units (AUX)
Priority 4	AUX Auxiliary control units, EDC control valve and Power Beyond
Transmission, hydraulic	1:11.1. Piston diameter D = 20 mm, d = 6 mm
P1 Pilot pressure auxiliary control units (AUX)	18+2 bar
Pressure on the TB port (with engine running):	
Service brake not activated	8 - 18 bar
Parking brake not activated	8 - 18 bar
Parking brake activated	0 bar
Service brake activated (brake pressure can be adjusted steplessly)	> 18 bar, max. 150 bar
Spring for max. brake pressure	Spring length 28.1 mm, spring Ø 20.5 mm, wire Ø 3.8 mm

### Hand brake valve

**NOTE:** Only in connection with Italian trailer brake - LT 43 HP G .

Version	3/2-port directional control valve
Drive	electro-magnetic
Parking brake open, magnet coil with flow	Pressures as on the TB port
Parking brake applied, magnet coil without flow	0 bar, spring actuator in the trailer is active
Electrical data of the magnet coil:	
Activation period	100%
Nominal voltage	12 V
Power consumption	Approx. 16W
Resistance	8.5 Ohm ±10%

### Priority valve with front axle brake valve LT 44 HP

**NOTE:** Is built in on tractors with braked front axle without hydraulic trailer brake.

Priority 1	Steering circuit
Priority 2	4-wheel brake
Priority 3	P1 Pilot pressure for auxiliary control units (AUX)

## Electro-hydraulic control valve - Remove

**NOTE:** Carefully clean the control unit block.

**ATTENTION:** Before commencing the disassembly work, ensure that the hydraulic system is depressurized.

**NOTE:** The required work steps for disassembling the individual auxiliary control units are not described for any particular auxiliary control unit in these instructions. The work steps are described such that with small variations, all of the auxiliary control units (1 to 8) and the EDC valve can be disassembled for all versions.

**NOTE:** Prior to disassembly check that all of the work steps listed are actually required for the auxiliary control unit to be disassembled. Depending on the quantity or position of the auxiliary control unit some disassembly steps may not be required.

### Remove auxiliary control units:

1. Position the rear of the tractor on a suitable axle stand and remove the rear right-hand wheel.
2. Open the hood. Put a suitable cab prop in place on the right-hand side, unscrew the retaining parts of the cab suspension unit on the right-hand side and remove the cab suspension unit.
3. Disassemble the connecting rod for the hand brake (if required) on the right-hand side. Unscrew the line from the end plate and the two hexagon nuts **(1)** (attachment of the end plate).

**NOTE:** All opening must be closed with suitable plugs after disassembling lines or hoses.

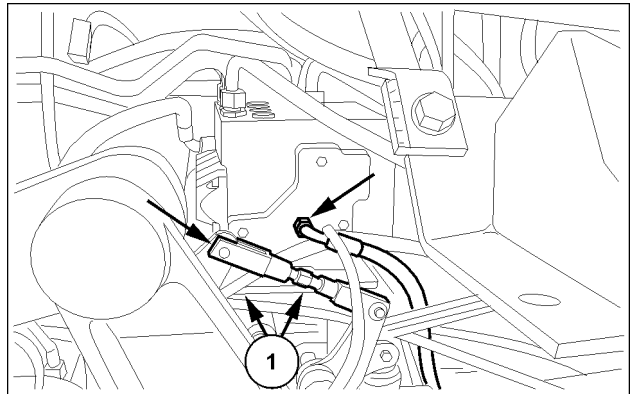
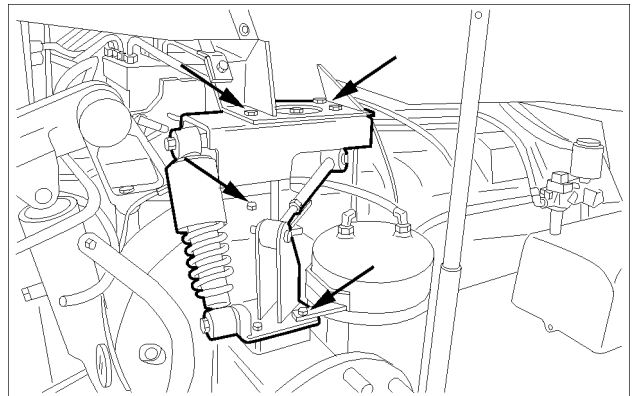



## **Hydraulic systems - 35**

### **Three-point hitch control valve - 114**

**T7510  
T7520  
T7530  
T7540  
T7550**

CLICK HERE TO **DOWNLOAD** THE COMPLETE MANUAL

- Thank you very much for reading the preview of the manual.
- You can download the complete manual from: [www.heydownloads.com](http://www.heydownloads.com) by clicking the link below



- Please note: If there is no response to CLICKING the link, please download this PDF first and then click on it.

CLICK HERE TO **DOWNLOAD** THE COMPLETE MANUAL



PRINTED IN FRANCE

© 2013 CNH GLOBAL N.V.

All rights reserved. No part of the text or illustrations of this publication may be reproduced.

NEW HOLLAND AGRICULTURE policy is one of continuous improvement and the right to change prices, specification or equipment at any time without notices is reserved.

All data given in this publication is subject to production variations. Dimensions and weight are approximate only and the illustrations do not necessarily show products in standard condition. For exact information about any particular product, please consult your NEW HOLLAND AGRICULTURE Dealer.



## **Steering - 41**

### **Autoguidance steering - 432**

**T7510  
T7520  
T7530  
T7540  
T7550**

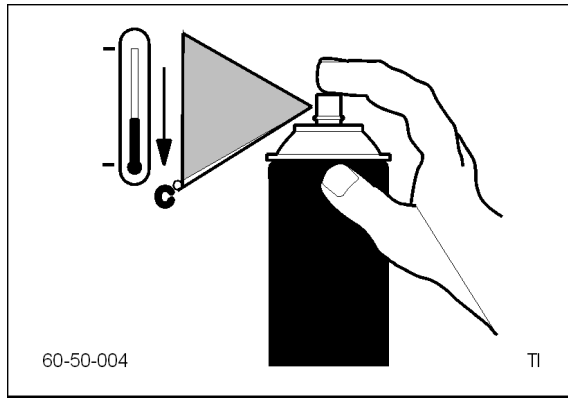

60-50-004 4

As we can see from the above, the main components of an air conditioning system are:

- Coolant
- Evaporator
- Compressor
- Condenser
- Drier/pressure vessel
- Expansion valve

## **Problem 2: Insufficient cooling.**

### **Cause:**

Refrigerant excessively low.

### **Conditions:**

- Low side pressure very low. Gauge should read **1 - 2 bar (15 - 29 psi)**.
- High side pressure too low. Gauge should read **16 - 18 bar (232 - 261 psi)**.
- Evaporator air warm.
- Low pressure switch cutting out.

### **Corrective procedures:**

1. Leak test the system.
2. Discharge and recover the refrigerant from the system.
3. Repair leaks.
4. Check compressor oil to ensure no loss.
5. Evacuate the system.
6. Charge the system.
7. Performance test the system.

### **Diagnosis:**

System refrigerant is extremely low. A serious leak is indicated.

## **Problem 3: Insufficient cooling.**

### **Cause:**

Air in system.

### **Conditions:**

- Low side pressure reading does not change when compressor cycles "on" and "off".
- High side pressure slightly high or slightly low. Gauge should read **16 - 18 bar (232 - 261 psi)**.
- Evaporator air not cold.

### **Corrective procedures:**

1. Leak test the system. Give special attention to the compressor seal area.
2. Discharge and recover the refrigerant from the system.
3. Repair leaks.
4. Replace the receiver/dryer.
5. Check compressor oil to ensure no loss.
6. Evacuate the system.
7. Charge the system.
8. Performance test the system.

### **Diagnosis:**

Air or moisture in system. System not fully charged.

## Assembly

4. If the condenser must be replaced, drain the cooling unit oil into a clean measuring container. Measure the amount of oil and fill the new condenser with the same amount of fresh cooling unit oil; refer to **Air-conditioning compressor - Filling (50.200)**.
5. Move the condenser into its installation position. Secure using the **(2)** bolts. Fit the **(1)** lines.

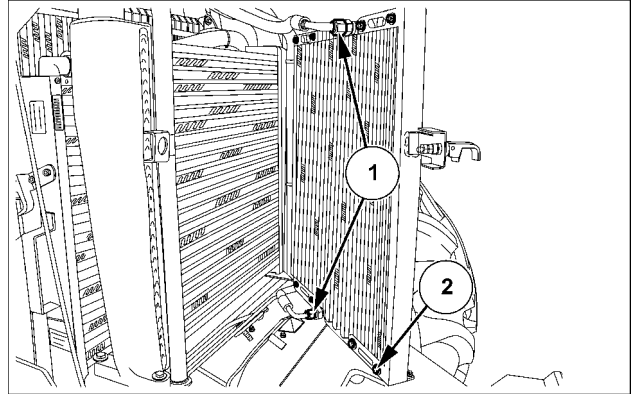

SS11G259 3

6. Close the tension lock.

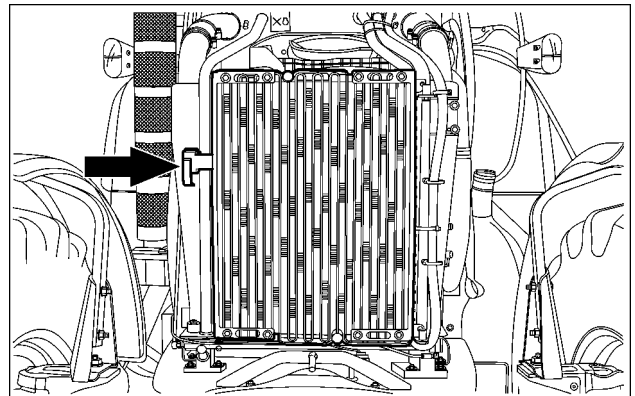

SS11G253 4

### Next operation:

**Air conditioning - Evacuate (50.200)**

**Air-conditioning compressor - Filling (50.200)**

**Air conditioning - Charging (50.200)**

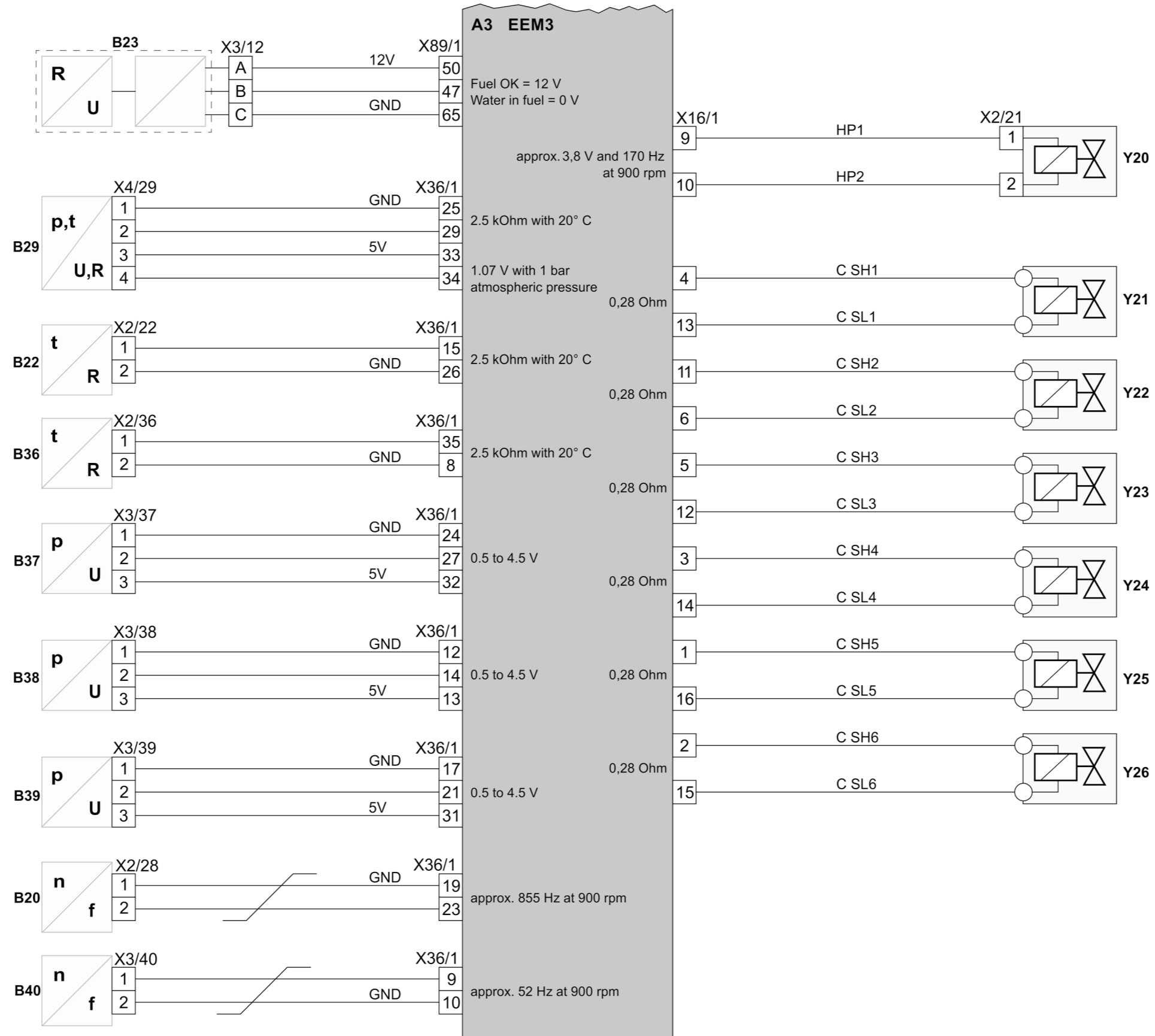

Functional schematic of components			
<b>(14)</b>	Cab floor grounding point	<b>S18/1</b>	Pressure in "-" BLUE <b>AUX</b> external button
A9	<b>ADIC</b>	<b>S18/2</b>	Pressure in "+" BLUE <b>AUX</b> external button
A12	Central print	<b>S19/1</b>	Pressure in "-" BROWN <b>AUX</b> external button
A30	<b>ARU</b> print	<b>S19/2</b>	Pressure in "+" BROWN <b>AUX</b> external button
A33	Printed pad	<b>X3/22</b>	Plug for angle sensor, linkage, front
A60	<b>ECCU3</b>	<b>X4/69</b>	Connector for cab wiring harness — external button for front linkage
B19	Front linkage rotational angle sensor	<b>X4/72</b>	Connector for cab wiring harness — front external <b>AUX</b> button, brown
<b>CN1a</b>	<b>ECCU3</b> plug	<b>X4/90</b>	<b>AUX1</b> plug
<b>CN3</b>	plug <b>ADIC</b>	<b>X6/4</b>	Connector for cab wiring harness — armrest supply
<b>CN3a</b>	<b>ECCU3</b> plug	<b>X10/4</b>	Connector for cab wiring harness — right control panel
<b>CN3b</b>	<b>ECCU3</b> plug	<b>X24/2</b>	Central print plug — cab wiring harness
<b>S2/7/3</b>	Hydraulics master switch	<b>X24/5</b>	Connector for cab wiring harness — right control panel
<b>S14/3</b>	External button for front linkage, LOWER	<b>X30/2</b>	<b>ARU</b> print plug — armrest wiring harness, CAN bus
<b>S15/3</b>	External button for front linkage, RAISE	X30/11	Print <b>ARU</b> plug — keypad

Overview Wiring harness, ISO BUS .....	306
- Overview Wiring harness, armrest .....	308
Overview Wiring harness, reverse drive unit .....	309
Overview Autoguidance wiring harness .....	311
Component diagram 01 Earth points .....	313
Component diagram 02 .....	318
Component diagram 03 .....	325
Component diagram 04 .....	331
Component diagram 05 .....	337
Component diagram 06 .....	341
Component diagram 07 .....	351
Component diagram 08 .....	358
Component diagram 09 .....	367
Component diagram 10 .....	376
Component diagram 11 .....	384
Component diagram 12 .....	395
Component diagram 13 .....	412
Component diagram 14 .....	422
Component diagram 15 .....	433
Component diagram 16 .....	447
Component diagram 17 .....	457
Component diagram 18 .....	472
Component diagram 19 .....	488
Component diagram 20 .....	501
<b>Diagnostic connector</b>	
Overview .....	512

## Wire harnesses - Electrical schema index

T7510 Einzel-Batterie, T7520 Einzel-Batterie, T7530 Einzel-Batterie, T7540 Einzel-Batterie, T7550 Einzel-Batterie

Designation of sections	Information unit
ADIC	Wire harnesses - Electrical schematic frame 22 (55.100)
Trailer brake, Italy version	Wire harnesses - Electrical schematic frame 08 (55.100)
Trailer brake, Italy version, for reversing unit	Wire harnesses - Electrical schematic frame 09 (55.100)
Work lamp on steps	Wire harnesses - Electrical schematic frame 14 (55.100)
Work lamp, rear left	Wire harnesses - Electrical schematic frame 14 (55.100)
Work lamp, rear right	Wire harnesses - Electrical schematic frame 14 (55.100)
Work lamp, mudguard	Wire harnesses - Electrical schematic frame 12 (55.100)
Work lamp, bonnet	Wire harnesses - Electrical schematic frame 15 (55.100)
Work lamp, front, x 2	Wire harnesses - Electrical schematic frame 14 (55.100)
Armrest, plastic foil keyboard	Wire harnesses - Electrical schematic frame 49 (55.100)
ASR with radar sensor	Wire harnesses - Electrical schematic frame 21 (55.100)
External push button, EDC	Wire harnesses - Electrical schematic frame 31 (55.100)
External push button, front AUX	Wire harnesses - Electrical schematic frame 44 (55.100)
External push button, front, Raise / Lower	Wire harnesses - Electrical schematic frame 29 (55.100)
<b>Autoguidance</b>	Wire harnesses - Electrical schematic frame 54 (55.100)
Push button, AUX	Wire harnesses - Electrical schematic frame 49 (55.100)
AUX valve 8	Wire harnesses - Electrical schematic frame 47 (55.100)
AUX valves	Wire harnesses - Electrical schematic frame 47 (55.100)
IM light, left	Wire harnesses - Electrical schematic frame 10 (55.100)
IM light, left and auxiliary light	Wire harnesses - Electrical schematic frame 11 (55.100)
IM light, right	Wire harnesses - Electrical schematic frame 10 (55.100)
IM light, right and auxiliary light	Wire harnesses - Electrical schematic frame 11 (55.100)
Lighting, steps	Wire harnesses - Electrical schematic frame 15 (55.100)
Hazard flashers for <b>ISO-BUS</b>	Wire harnesses - Electrical schematic frame 10 (55.100)
Brake light	Wire harnesses - Electrical schematic frame 06 (55.100)
Brake light for reversing unit	Wire harnesses - Electrical schematic frame 07 (55.100)
Brake oil cooling	Wire harnesses - Electrical schematic frame 36 (55.100)



## Wire harnesses - Electrical schematic frame 14 Work Lamp

T7510 Einzel-Batterie, T7520 Einzel-Batterie, T7530 Einzel-Batterie, T7540 Einzel-Batterie, T7550 Einzel-Batterie

### Sections

- A Working light, rear left  
See **Wire harnesses - Electrical schematic frame 12 (55.100)**  
for variantSee **Wire harnesses - Electrical schematic frame 13 (55.100)**  
for variant
- B Working light, rear right  
See **Wire harnesses - Electrical schematic frame 12 (55.100)**  
for variantSee **Wire harnesses - Electrical schematic frame 13 (55.100)**  
for variant
- C Working light, front, 2-way  
See **Wire harnesses - Electrical schematic frame 12 (55.100)**  
for variantSee **Wire harnesses - Electrical schematic frame 13 (55.100)**  
for variant
- D Working light on entry step
- E Ancillary lamp, flasher, roof brake light

### Grounding points

No grounding points

**NOTE:** Spot welds are depicted in the circuit diagram with the identification X0/./.. (e.g. X0/28/13)

Color coding table							
A	Red	B	Beige	C	White	D	Yellow
E	Grey	F	Green	G	Violet	H	Orange
K	Light blue	L	Brown	M	Ground Strap	N	Pink
P	No color	S	Black				

### Components

A13	Roof print	T5/4WKL-F	Fuse for working light roof, front, exterior
A60	ECCU3	T5/4WKL-R	Fuse for working light roof, rear, exterior
A64	Work light panel	<b>X1/30/ROOF</b>	Roof print bolt connection, roof supply, Potential 30
<b>CN3a</b>	ECCU3 plug	<b>X2/14</b>	Working light plug, front right
E23/2	Working light, rear left, exterior	<b>X2/15</b>	Working light plug, front left
E24/2	Working light, rear right, exterior	<b>X2/29</b>	Plug for working light on entry step, right
<b>E33</b>	Working light, front left, interior	<b>X2/30</b>	Plug for working light on entry step, left
<b>E34</b>	Working light, front right, interior	<b>X4/48</b>	Plug for roof - working light, rear right wiring harness
E35	Working light on entry step, left	<b>X4/49</b>	Plug for roof - working light, rear left wiring harness
E36	Working light on entry step, right	<b>X6/26</b>	Plug for roof - ancillary lamp, flasher, brake light wiring harness
F103	Working light front, exterior fuse	<b>X6/ROOF2</b>	Roof print plug, roof
F104	Working light rear, exterior fuse	<b>X10/ROOF1</b>	Roof print plug supply, roof
F107	Working light rear, interior and exterior fuse	<b>X14/RO/SUP</b>	Cab - roof wiring harness connector
F109	Working light supply fuse - panel, Potential 30	<b>X24/6</b>	Working light, panel plug

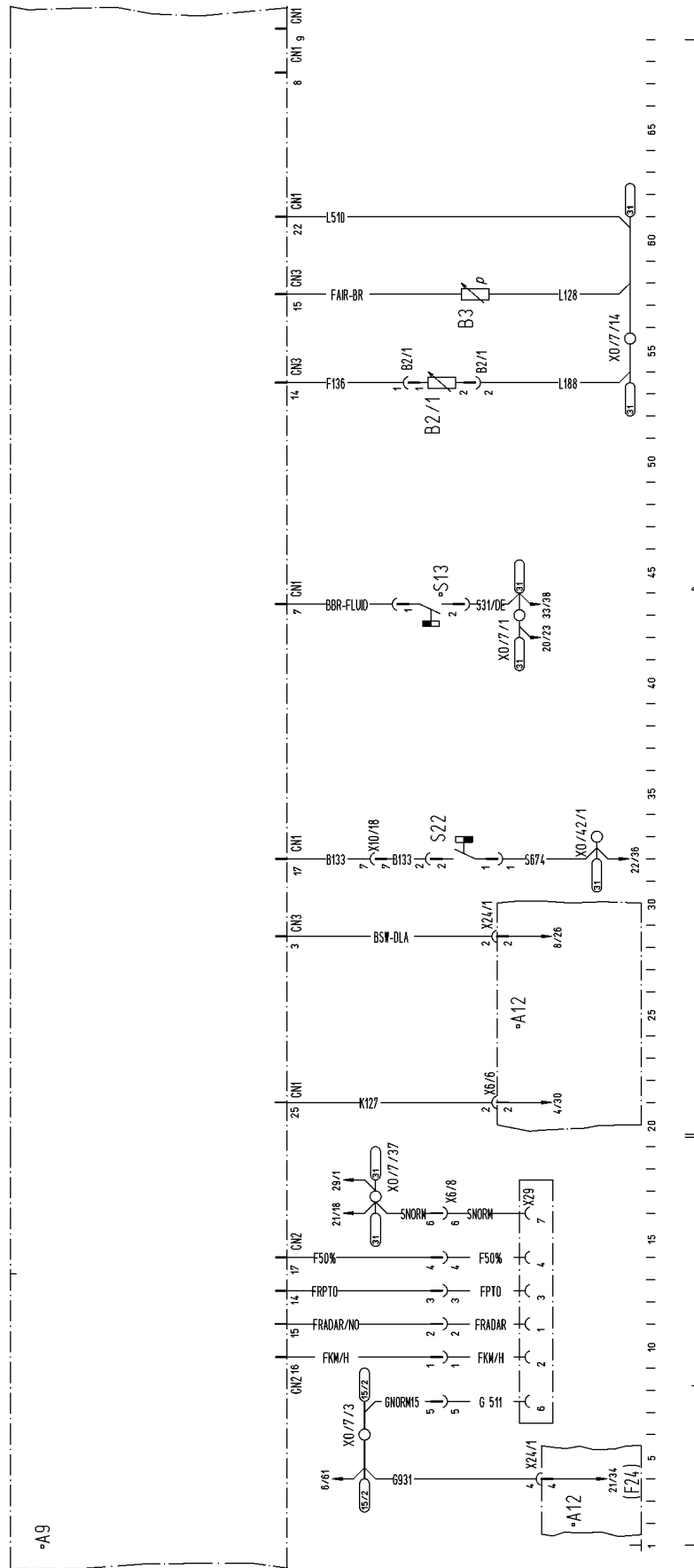

SS10A143 1

## Wire harnesses - Electrical schematic frame 33 Vehicle/engine/gearbox controller (FMGR)

T7510 Einzel-Batterie, T7520 Einzel-Batterie, T7530 Einzel-Batterie, T7540 Einzel-Batterie, T7550 Einzel-Batterie

### Sections

- A FMGR supply
- B Clutch switch 80%  
See **Wire harnesses - Electrical schematic frame 34 (55.100)** for variant
- C Clutch angle encoder  
See **Wire harnesses - Electrical schematic frame 34 (55.100)** for variant
- D Accelerator pedal potentiometer  
See **Wire harnesses - Electrical schematic frame 34 (55.100)** for variant
- E Parking lock switch  
See **Wire harnesses - Electrical schematic frame 35 (55.100)** for variant
- F Load limit potentiometer  
See **Wire harnesses - Electrical schematic frame 35 (55.100)** for variant
- G Exhaust brake switch  
See **Wire harnesses - Electrical schematic frame 35 (55.100)** for variant
- H Seat switch, handbrake switch  
See **Wire harnesses - Electrical schematic frame 35 (55.100)** for variant

### Grounding points

No grounding points

**NOTE:** Spot welds are depicted in the circuit diagram with the identification X0/./.. (e.g. X0/28/13)

Color coding table							
A	Red	B	Beige	C	White	D	Yellow
E	Grey	F	Green	G	Violet	H	Orange
K	Light blue	L	Brown	M	Ground Strap	N	Pink
P	No color	S	Black				

### Components

A3	EEM3 controller	<b>S2/61</b>	Parking lock switch
A4	FMGR box	S8	Seat switch
<b>A4/1</b>	FMGR plug, white	<b>S20</b>	Exhaust brake switch
<b>A4/2</b>	FMGR plug, dark gray	S21	Handbrake switch
<b>A4/3</b>	FMGR plug, blue	<b>S46</b>	Clutch switch <b>80 %</b>
<b>A4/4</b>	FMGR plug, gray	<b>X4/25</b>	Handbrake switch plug
A12	Central print	<b>X4/61</b>	Cab wiring harness connector - Grammer seat
<b>B17</b>	Clutch angle encoder	<b>X4/70</b>	Cab - wiring harness connector - accelerator pedal
E45	Illumination potentiometer, load limit	<b>X10/18</b>	Cab - motor wiring harness connector
F10	Supply fuse, FMGR, Potential 30	<b>X12/2</b>	Cab wiring harness connector - auxiliary line for potentiometer EDC
F47	Supply fuse, FMGR, Potential 15/1	<b>X24/2</b>	Central print plug — cab wiring harness
R8	Accelerator pedal potentiometer	<b>X89/1</b>	EEM3 controller plug - motor wiring harness
R23	Load limit potentiometer		

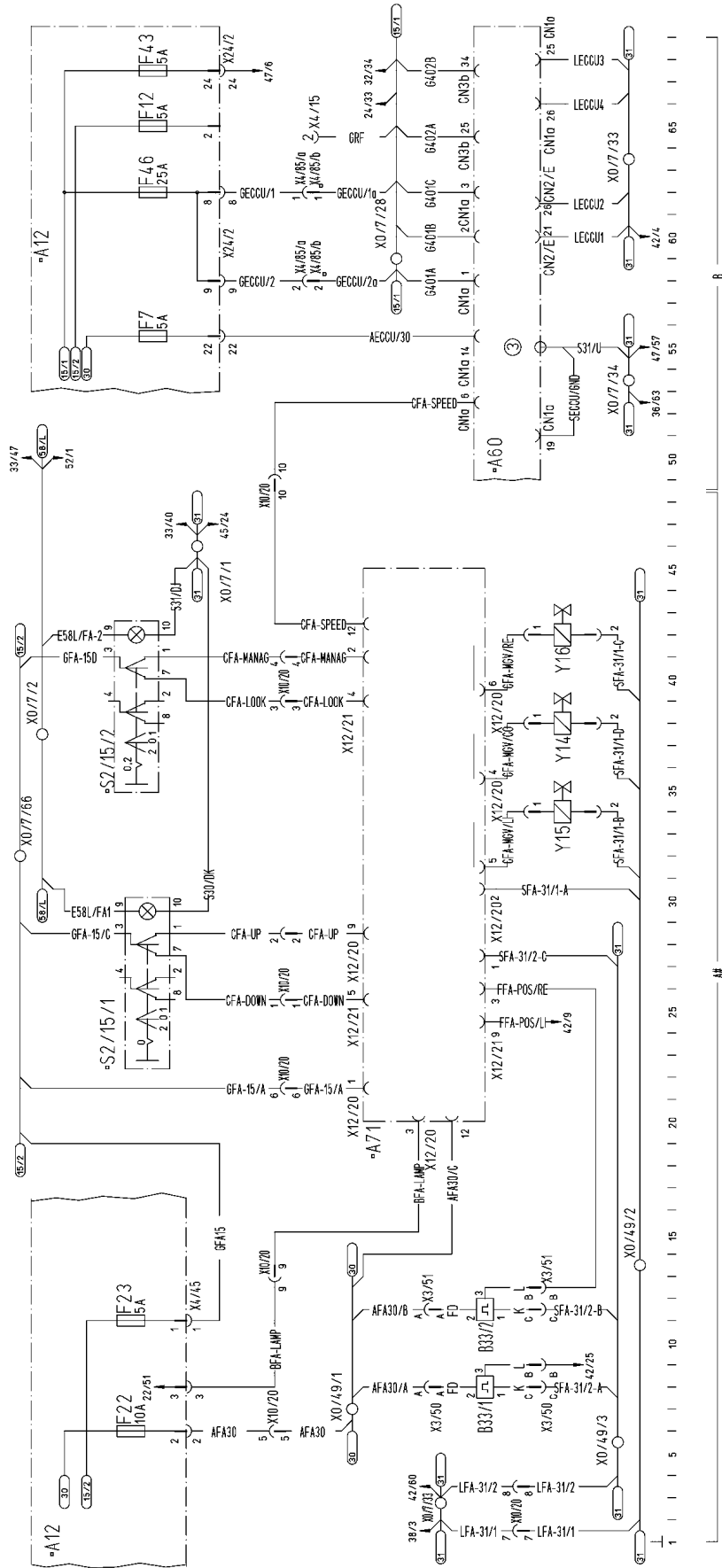

SS12G003 1

## Wire harnesses - Electrical schematic frame 52 ISO-BUS/power socket

T7510 Einzel-Batterie, T7520 Einzel-Batterie, T7530 Einzel-Batterie, T7540 Einzel-Batterie, T7550 Einzel-Batterie

### Sections

- A **ISO-BUS**  
See **Wire harnesses - Electrical schematic frame 53 (55.100)** for variant
- B **ISO-BUS, CAN BUS**
- C Power socket 2, rear

### Grounding points

- 14 Cab floor

**NOTE:** Spot welds are depicted in the circuit diagram with the identification X0/././.. (e.g. X0/28/13)

Color coding table							
A	Red	B	Beige	C	White	D	Yellow
E	Grey	F	Green	G	Violet	H	Orange
K	Light blue	L	Brown	M	Ground Strap	N	Pink
P	No color	S	Black				

### Components

A12	Central print	P9	Monitor <b>ISO-BUS</b>
A14	Motor print	V8/1	Diode group <b>ISO-BUS</b>
A60	ECCU3	X1/15//ISO	Motor print plug <b>ISO-BUS</b> Potential 15/1
CN1a	ECCU3 plug	X1/30//ISO	Motor print bolt connection <b>ISO-BUS</b> Potential 30
CN3b	ECCU3 plug	X2//ISO	Motor print plug <b>ISO-BUS</b> Potential 30
CN4	ECCU3 plug <b>ISO-BUS</b>	X3/85	Final resistance plug <b>ISO-BUS</b>
CN5	Monitor plug <b>ISO-BUS</b>	X4/85/a	Connector for cab wiring harness — power supply optional
F46	Fuse for ECCU3 supply, potential 15/1	X4/85/b	Connector for cab wiring harness — power supply optional
F216	Power socket fuse, front, <b>ISO-BUS</b> monitor, Potential 15	X4/86	Plug <b>ISO-BUS</b> socket
F219	Fuse <b>ISO-BUS</b> Potential 30	X9/17	Diagnostics Service Tool socket
F220	Fuse <b>ISO-BUS</b> Potential 30	X9/20	Socket <b>ISO-BUS</b>
F222	Socket fuse <b>ISO-BUS</b> , power socket 2, Potential 30	X14/20	Power socket 2, rear <b>60 A</b>
K5/80	Relay <b>ISO-BUS</b> , Potential 15	X24/2	Central print plug — cab wiring harness
K5/81	Relay <b>ISO-BUS</b> ECU Power	X85	Plug <b>ISO-BUS</b> socket
K5/82	Relay <b>ISO-BUS</b> power socket		

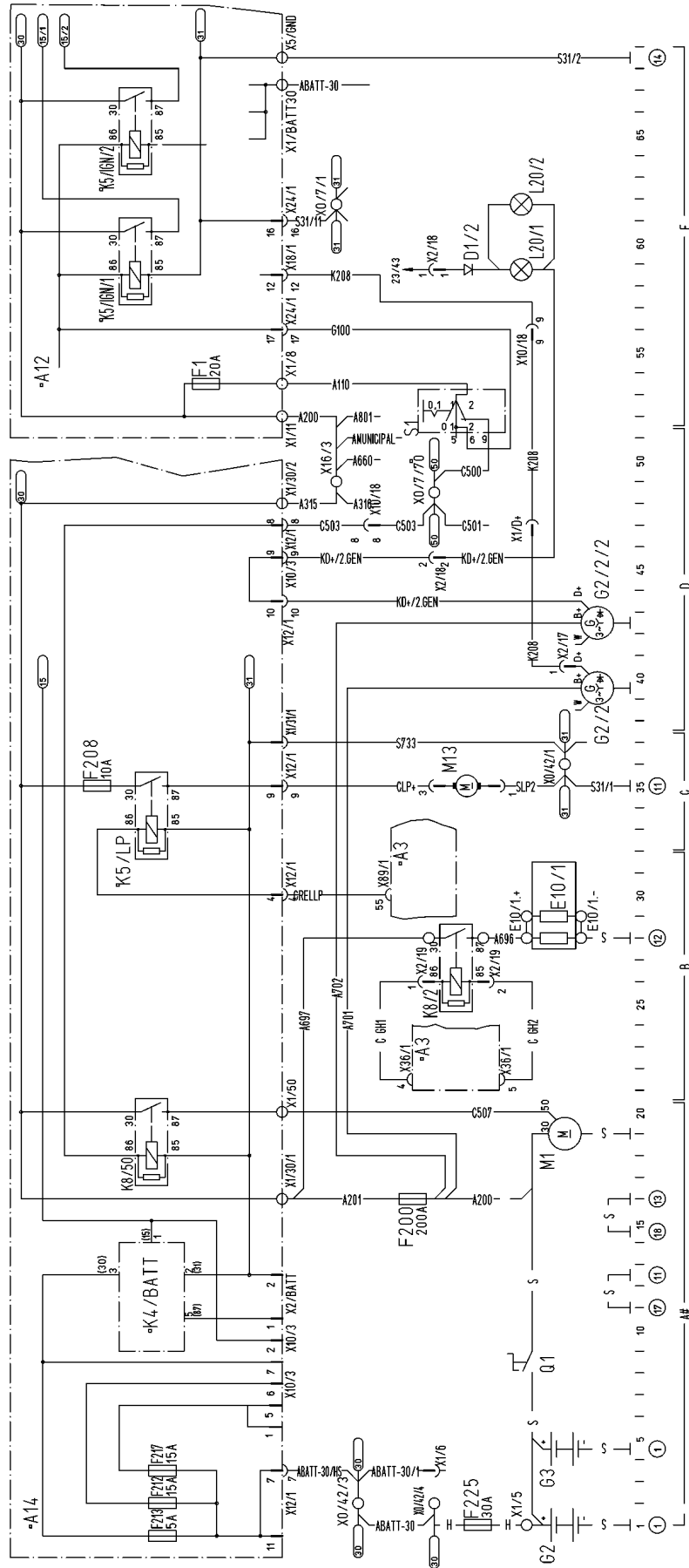

SS10D101 1

## Wire harnesses - Electrical schematic frame 11 Flasher/position lamps with ancillary lights/brake lights

T7510 Doppel-Batterie, T7520 Doppel-Batterie, T7530 Doppel-Batterie, T7540 Doppel-Batterie, T7550 Doppel-Batterie

### Sections

- A Flashing unit on **ISO-BUS**
- B SBB lamp, left and ancillary lamp  
See **Wire harnesses - Electrical schematic frame 10 (55.100)** for variant
- C SBB lamp, right and ancillary lamp  
See **Wire harnesses - Electrical schematic frame 10 (55.100)** for variant
- D BB lamp, left and ancillary lamp  
See **Wire harnesses - Electrical schematic frame 10 (55.100)** for variant
- E BB lamp, right and ancillary lamp  
See **Wire harnesses - Electrical schematic frame 10 (55.100)** for variant

### Grounding points

- 14 Cab floor

**NOTE:** Spot welds are depicted in the circuit diagram with the identification X0/./.. (e.g. X0/28/13)

Color coding table							
A	Red	B	Beige	C	White	D	Yellow
E	Grey	F	Green	G	Violet	H	Orange
K	Light blue	L	Brown	M	Ground Strap	N	Pink
P	No color	S	Black				

### Components

A12	Central print	T2/FLASH	Relay, flasher
A13	Roof print	T5/58	Light relay, Potential 58
E3	Position lamp, front left	<b>S2/5</b>	Hazard flasher switch
E4	Position Rear Lamp LH	S4/2	Steering column flasher switch
E6	Position lamp, front right	<b>X2/84L</b>	Cab - ancillary position lamp, rear left wiring harness connector
E7	Position Rear Lamp RH	<b>X2/84R</b>	Cab - ancillary position lamp, rear right wiring harness connector
E12	Brake light, left	<b>X4/18</b>	Connector BB - lamp, right
E12/1	Ancillary position lamp, rear left	<b>X4/19</b>	Connector BB - lamp, left
E13	Brake light, right	<b>X4/60L</b>	Connector SBB - lamp, left
E13/1	Ancillary position lamp, rear right	<b>X4/60R</b>	Connector SBB - lamp, right
E14	Flasher, front right	<b>X6/5</b>	Central print plug, supply, Potential 30
E15	Flasher, rear right	<b>X10/8</b>	Central print plug — cab wiring harness
E16	Flasher, rear left	<b>X10/CAB</b>	Roof print plug supply
E17	Flasher, front left	<b>X10/ROOF1</b>	Roof print plug supply, roof
F4	Reserve fuse, Potential 30	<b>X14/8</b>	Connector for cab - steering column switch wiring harness
F18	SBB fuse, lighting switch, instrument panel, ADIC Potential 58L	<b>X14/15</b>	Central print plug - cab wiring harness supply, roof
F19	SBB fuse, control panel right illumination, cigarette lighter, ARU, ECCU3, Potential 58R	<b>X14/RO/SUP</b>	Cab - roof wiring harness connector
F29	Supply fuse for flasher, Potential 15/1	<b>X18/1</b>	Central print plug — cab wiring harness
F50	Hazard light unit fuse, Potential 30 / X6/5	<b>X24/1</b>	Central print plug — cab wiring harness
F114	Position lamp left fuse, license plate illumination left, beacon light bars	<b>X24/2</b>	Central print plug — cab wiring harness
F115	Position light right fuse, license plate illumination right, work light panel radio		

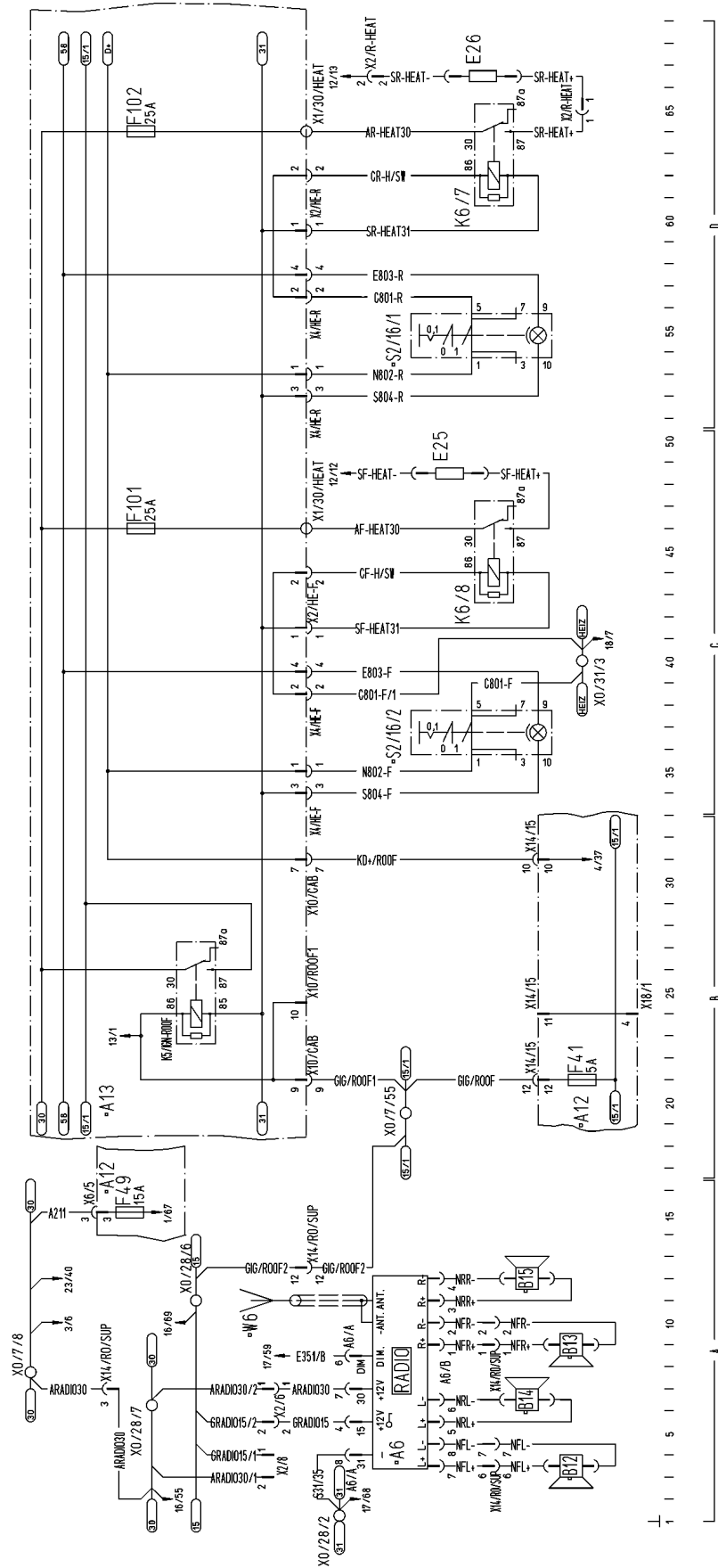

SS10C042 1

## Wire harnesses - Electrical schematic frame 29 Electr. linkage, rear with stroke-pressure control

T7510 Doppel-Batterie, T7520 Doppel-Batterie, T7530 Doppel-Batterie, T7540 Doppel-Batterie, T7550 Doppel-Batterie

### Sections

- A EDC box supply
- B EDC with stroke/pressure  
See **Wire harnesses - Electrical schematic frame 28 (55.100)** for variant
- C Force sensors
- D EDC angle encoder
- E EDC solenoid valves

### Grounding points

No grounding points

**NOTE:** Spot welds are depicted in the circuit diagram with the identification X0/./.. (e.g. X0/28/13)

Color coding table							
A	Red	B	Beige	C	White	D	Yellow
E	Grey	F	Green	G	Violet	H	Orange
K	Light blue	L	Brown	M	Ground Strap	N	Pink
P	No color	S	Black				

### Components

A12	Central print	<b>S28</b>	Stroke/pressure switchover
A14	Motor print	<b>X2/12a</b>	Cab wiring harness plug - stroke/pressure preparation
A25	EDC box	<b>X2/12b</b>	Cab wiring harness plug - stroke/pressure preparation
<b>B9/1</b>	EDC angle encoder	<b>X6/2</b>	Motor print plug — cab wiring harness
<b>B10/1</b>	Force sensor, left	<b>X24/2</b>	Central print plug — cab wiring harness
<b>B10/2</b>	Force sensor, right	<b>X25</b>	EDC box plug
F45	Supply fuse for EDC Box, Potential 15/1	<b>Y6</b>	EDC RAISE solenoid valve
F210	EDC Box fuse, Potential 30	<b>Y7</b>	EDC LOWER solenoid valve



## Wire harnesses - Electrical schematic frame 48 Auxiliary Controller

T7510 Doppel-Batterie, T7520 Doppel-Batterie, T7530 Doppel-Batterie, T7540 Doppel-Batterie, T7550 Doppel-Batterie

### Sections

- A AUX valves  
See **Wire harnesses - Electrical schematic frame 49 (55.100)** for variant
- B AUX valve 8
- C Heating valve for hydraulic oil

### Grounding points

- 14 Cab floor

**NOTE:** Spot welds are depicted in the circuit diagram with the identification X0/./.. (e.g. X0/28/13)

Color coding table							
A	Red	B	Beige	C	White	D	Yellow
E	Grey	F	Green	G	Violet	H	Orange
K	Light blue	L	Brown	M	Ground Strap	N	Pink
P	No color	S	Black				

### Components

(A8)	Armrest	<b>S2/78</b>	Key switch, auxiliary controller 8
A12	Central print	<b>X4/85/a</b>	Connector for cab wiring harness — power supply optional
A60	ECCU3	<b>X4/90</b>	AUX1 plug
<b>CN1b</b>	ECCU3 plug	<b>X6/4</b>	Connector for cab wiring harness — armrest supply
<b>CN3b</b>	ECCU3 plug	<b>Y8</b>	Heating valve
F46	Fuse for ECCU3 supply, potential 15/1		

## Wire connectors - Overview Wiring harness overview

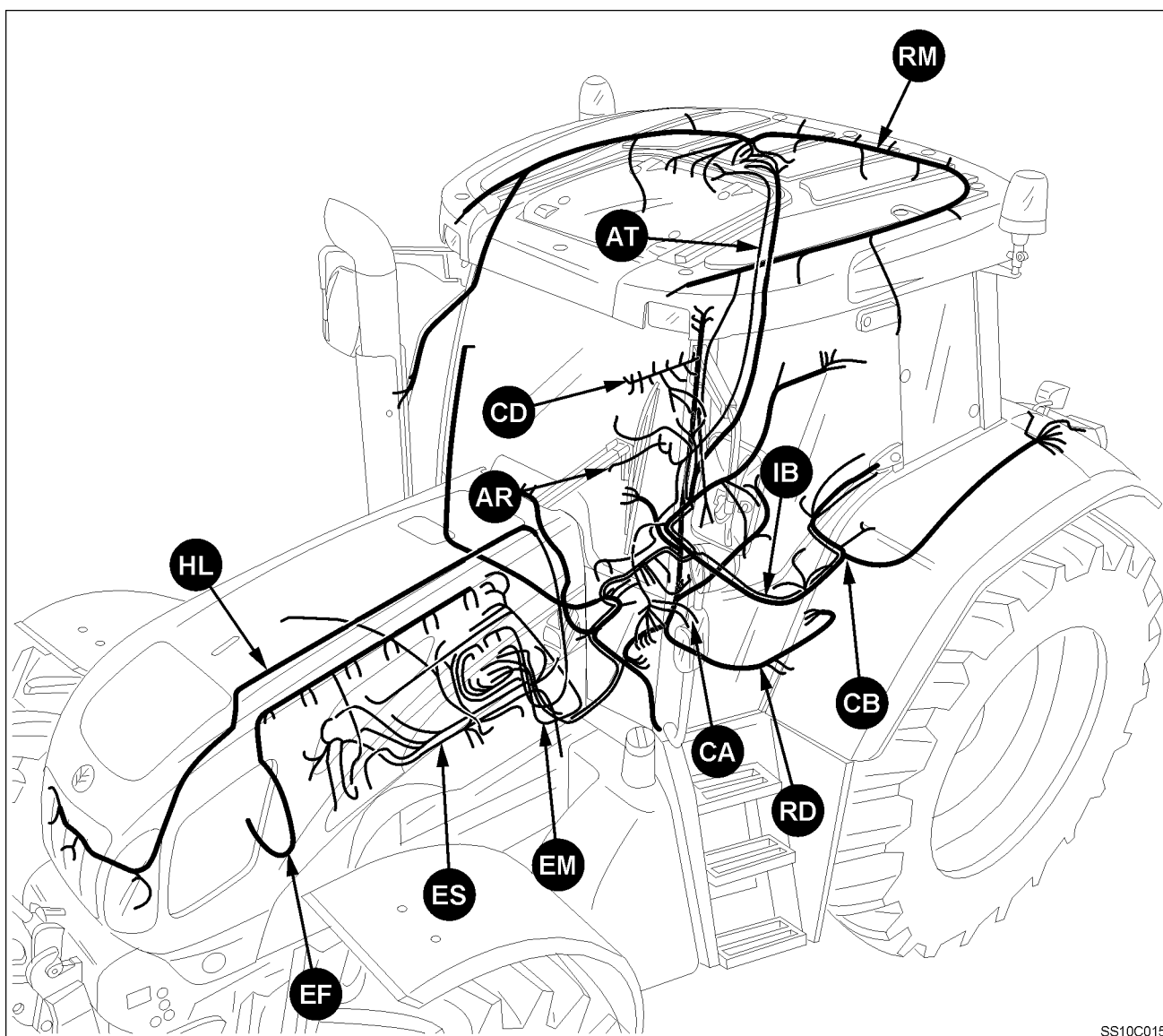

SS10C015

SS10C015 1

<b>HL</b> Wiring harness, bonnet	<b>Wire connectors - Overview (55.100)</b>
<b>EM</b> Wiring harness, engine	<b>Wire connectors - Overview (55.100)</b>
<b>EF</b> Wiring harness, engine - injectors	<b>Wire connectors - Overview (55.100)</b>
<b>ES</b> Wiring harness, engine - sensors	<b>Wire connectors - Overview (55.100)</b>
<b>CB</b> Wiring harness, cab	<b>Wire connectors - Overview (55.100)</b>
<b>CD</b> Wiring harness, right control panel	<b>Wire connectors - Overview (55.100)</b>
<b>AR</b> Wiring harness, armrest	<b>Wire connectors - Overview (55.100)</b>
<b>CA</b> Wiring harness, cartridge	<b>Wire connectors - Overview (55.100)</b>
<b>RM</b> Wiring harness, roof	<b>Wire connectors - Overview (55.100)</b>
<b>IB</b> Wiring harness <b>ISO-BUS</b>	<b>Wire connectors - Overview (55.100)</b>
<b>RD</b> Wiring harness, reverse drive unit [Z7SC03132→]	<b>Wire connectors - Overview (55.100)</b>
<b>AT</b> Wiring harness <b>Autoguidance</b>	<b>Wire connectors - Overview (55.100)</b>



## Wire connectors - Overview Autoguidance wiring harness

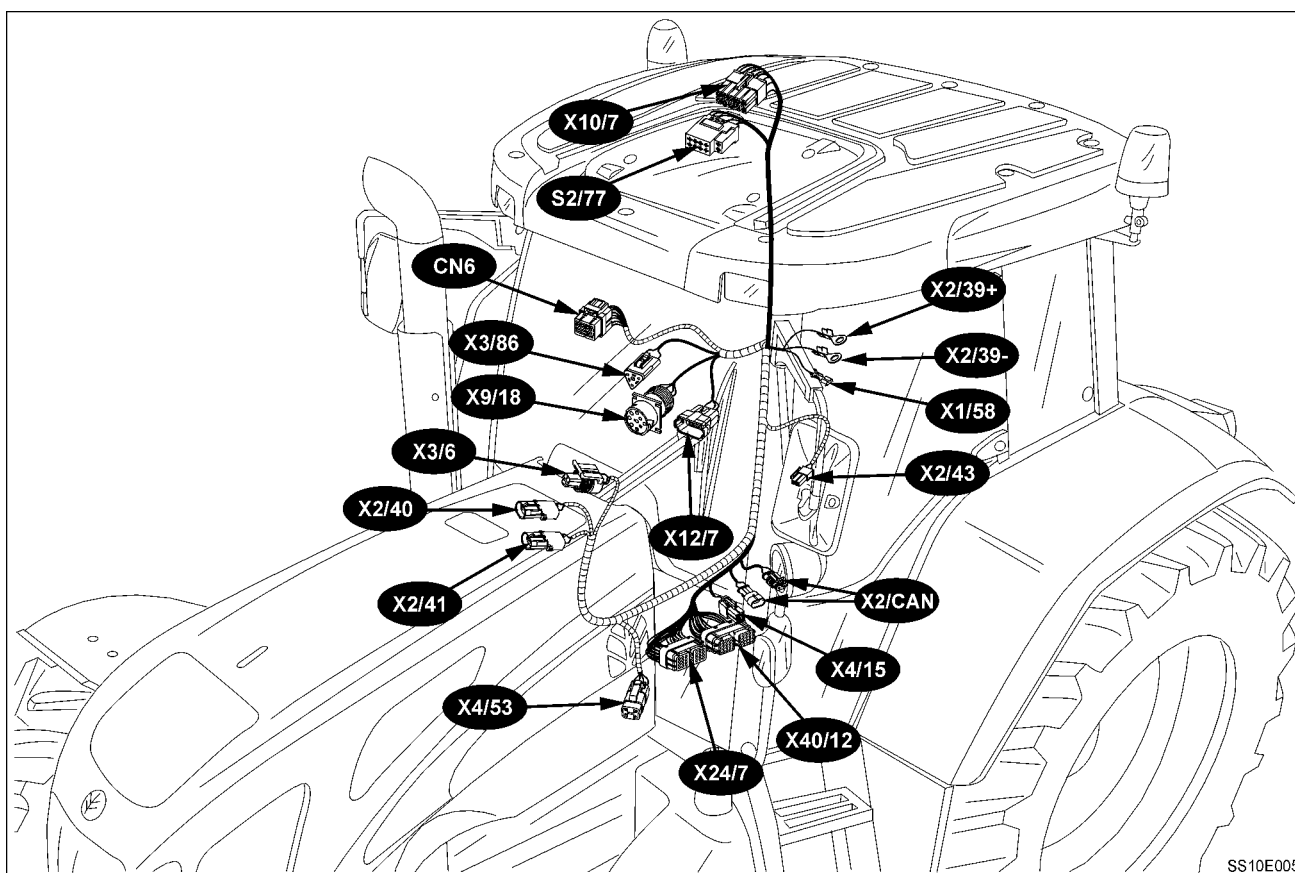

SS10E005

SS10E005 1

<b>CN6</b>	Plug, monitor <b>Autoguidance</b>	<b>Wire connectors - Component diagram 04 (55.100)</b>
<b>S2/77</b>	Plug, main switch <b>Autoguidance</b>	<b>Wire connectors - Component diagram 09 (55.100)</b>
<b>X1/58</b>	Plug, cigarette lighter supply, potential 58 <b>Autoguidance</b>	<b>Wire connectors - Component diagram 11 (55.100)</b>
<b>X2/39</b>	Clamping bushing red/black, control panel right, and supply <b>Autoguidance</b>	<b>Wire connectors - Component diagram 14 (55.100)</b>
<b>X2/40</b>	Plug, solenoid valve, steering, right <b>Autoguidance</b>	
<b>X2/41</b>	Plug, solenoid valve, steering, left <b>Autoguidance</b>	
<b>X2/43</b>	Plug-in connector <b>Autoguidance</b> push button	
<b>X2/CAN</b>	Plug connection for wiring harness, cab - <b>CAN BUS</b> interface	<b>Wire connectors - Component diagram 15 (55.100)</b>
<b>X3/6</b>	Plug, <b>Autoguidance</b> pressure sensor	<b>Wire connectors - Component diagram 16 (55.100)</b>
<b>X3/86</b>	Plug, terminal resistor <b>Autoguidance</b>	
<b>X4/15</b>	Plug connection for wiring harness, cab - potential 15 optional	<b>Wire connectors - Component diagram 17 (55.100)</b>
<b>X4/53</b>	Plug connection, steering angle sensor <b>Autoguidance</b>	
<b>X9/18</b>	Socket, diagnosis <b>Autoguidance</b>	<b>Wire connectors - Component diagram 19 (55.100)</b>
<b>X10/7</b>	Plug connection, <b>Autoguidance</b> roof	<b>Wire connectors - Component diagram 12 (55.100)</b>
<b>X12/7</b>	Plug connection, <b>Autoguidance</b> interface RS 232	
<b>X24/7</b>	Plug, <b>Autoguidance</b> controller	<b>Wire connectors - Component diagram 15 (55.100)</b>
<b>X40/12</b>	Plug, <b>Autoguidance</b> controller	<b>Wire connectors - Component diagram 18 (55.100)</b>

**B7 - Plug, speed sensor, rear PTO shaft**

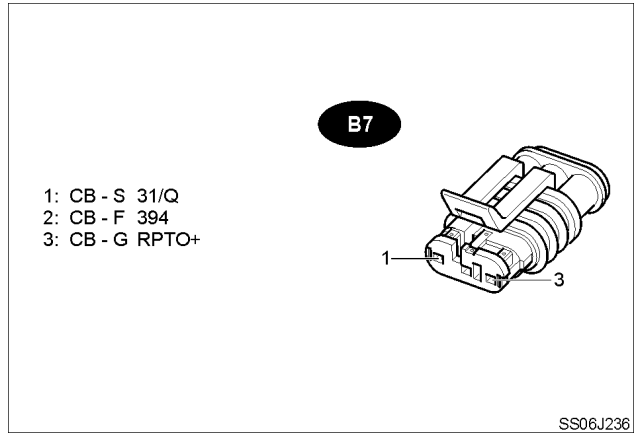
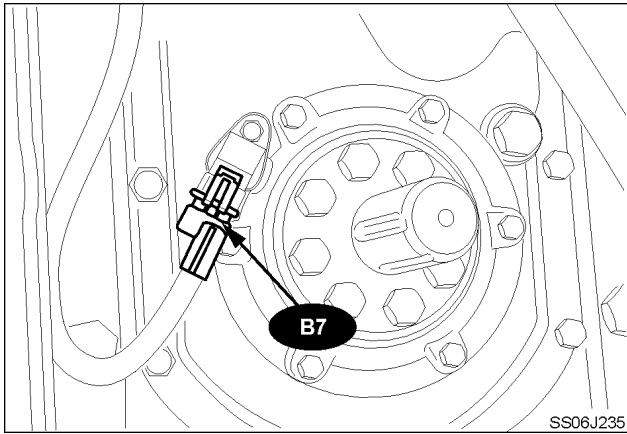

**B8 - Plug, speed sensor, front PTO shaft**

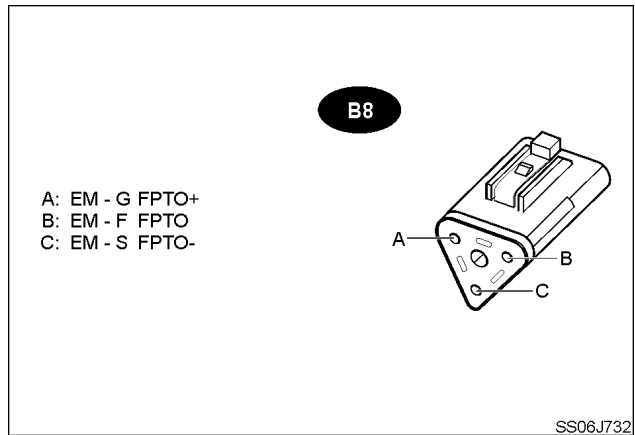
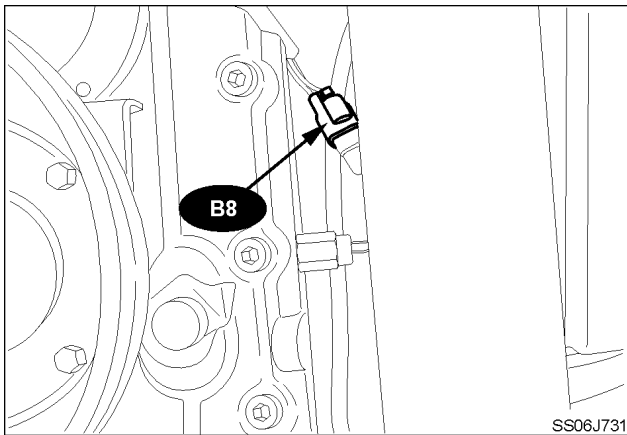

**B9/1 - Plug, angle of rotation sensor, EDC**

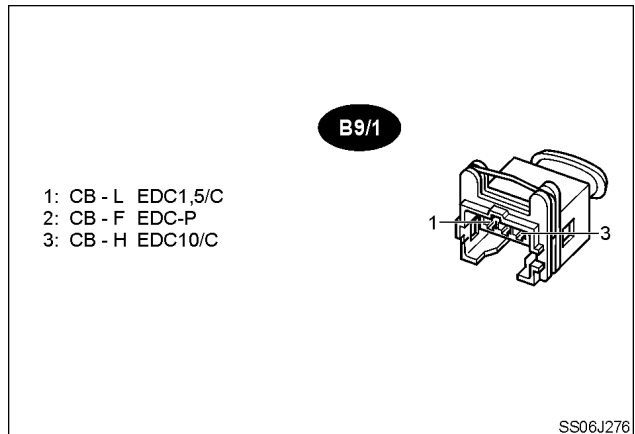
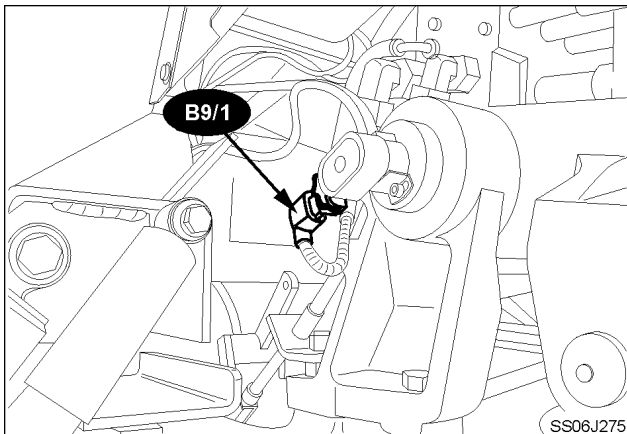

**K5/LOADER1 - Base, relay, solenoid valve, front loader 1**

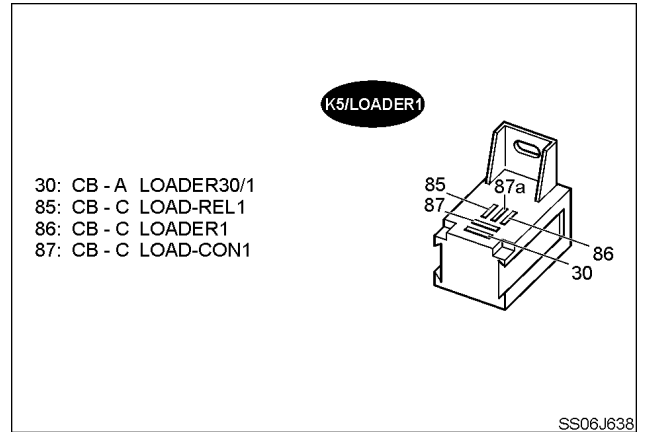
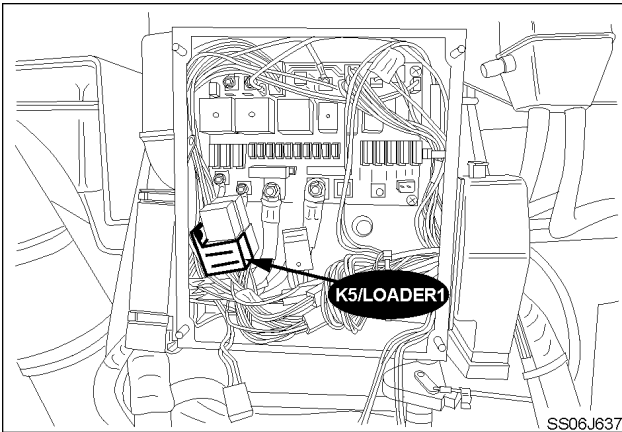

**K5/LOADER2 - Base, relay, solenoid valve, front loader 2**

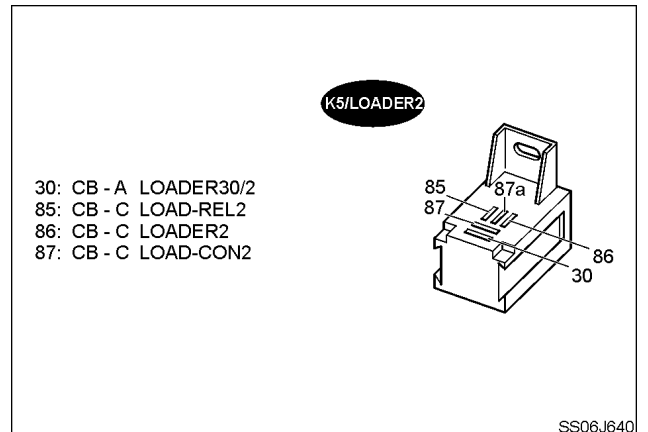
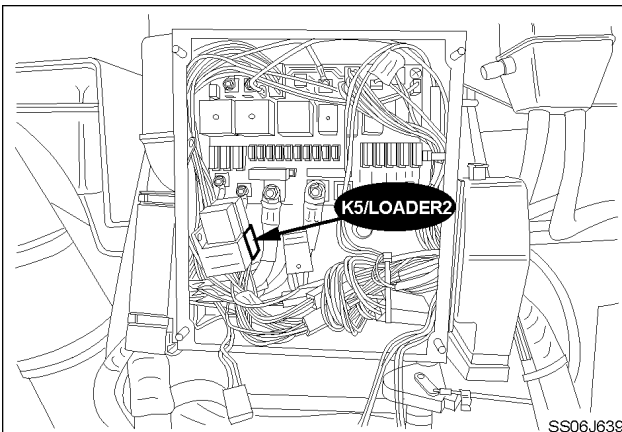

**K6/7 - Base, relay, heated windscreen, rear**

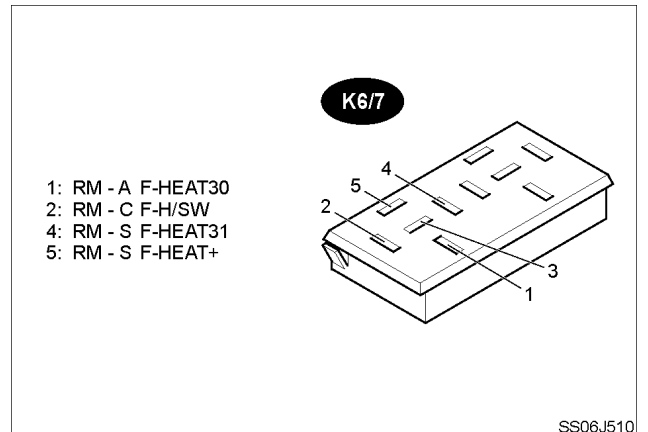
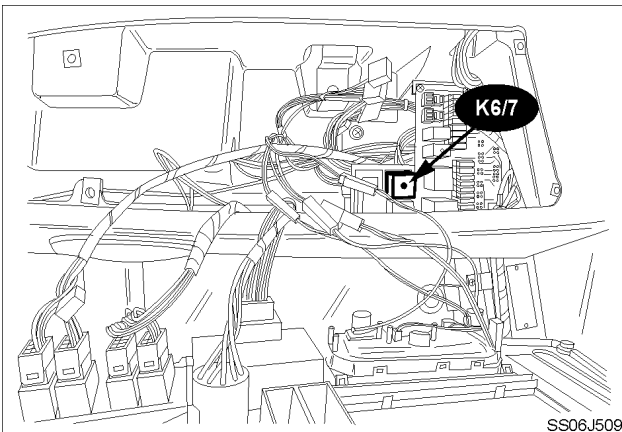

**S2/2 - Plug, switch, parking light**

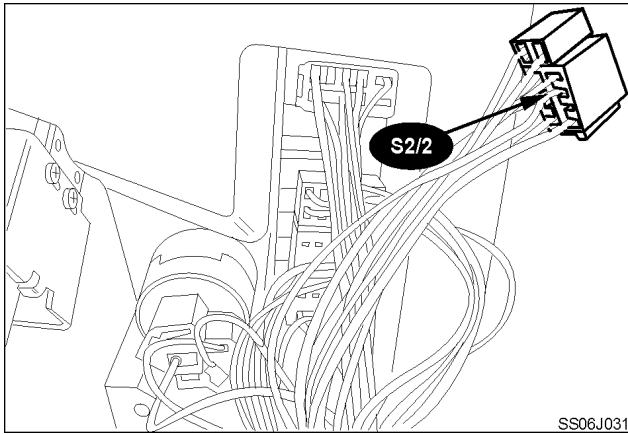

SS06J031 5

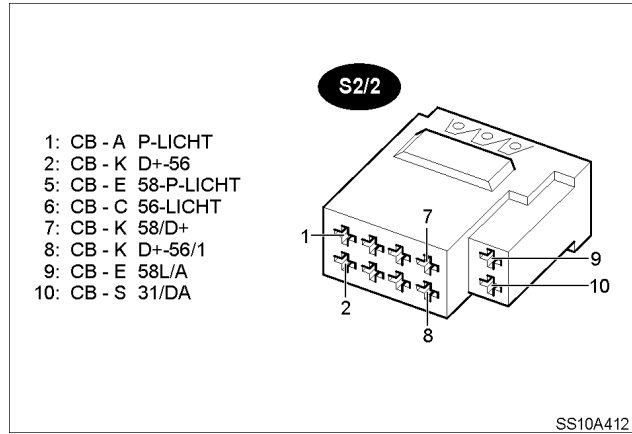

- 1: CB - A P-LICHT
- 2: CB - K D+-56
- 5: CB - E 58-P-LICHT
- 6: CB - C 56-LICHT
- 7: CB - K 58/D+
- 8: CB - K D+-56/1
- 9: CB - E 58L/A
- 10: CB - S 31/DA

SS10A412 6

**S2/30 - Plug, switch, windscreen wiper, rear**

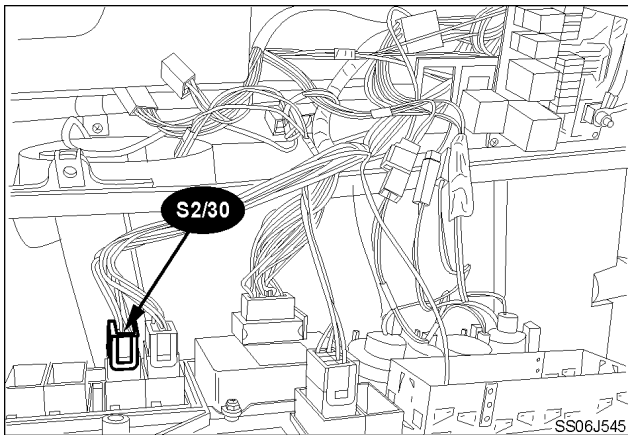

SS06J545 7

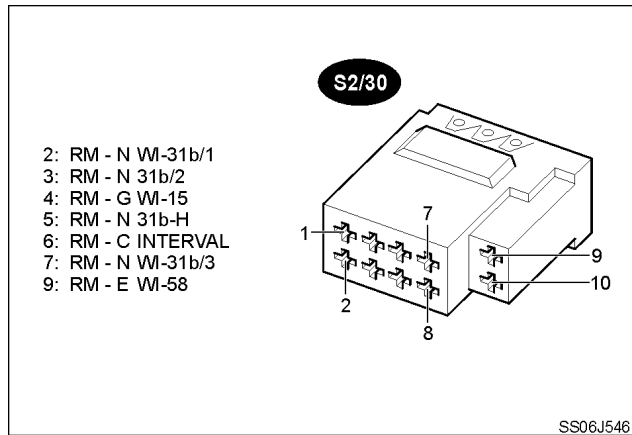

- 2: RM - N WI-31b/1
- 3: RM - N 31b/2
- 4: RM - G WI-15
- 5: RM - N 31b-H
- 6: RM - C INTERVAL
- 7: RM - N WI-31b/3
- 9: RM - E WI-58

SS06J546 8

**X1/30/ABS - Screw connection, engine PCB, ABS - socket potential 30**

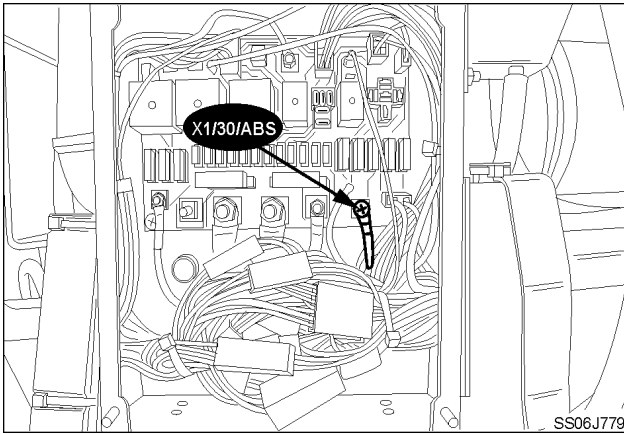

SS06J779 18

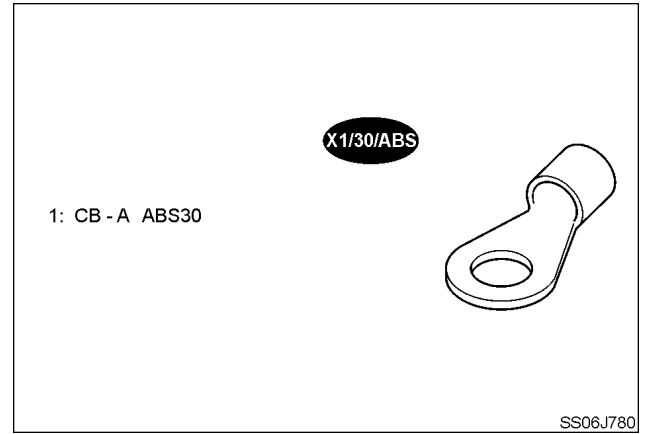

SS06J780 19

**X1/30/EEM - Screw connection, engine PCB, EEM3 control unit, potential 30**

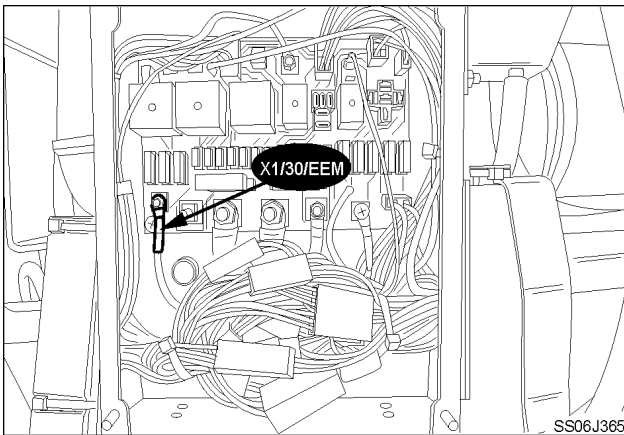

SS06J365 20

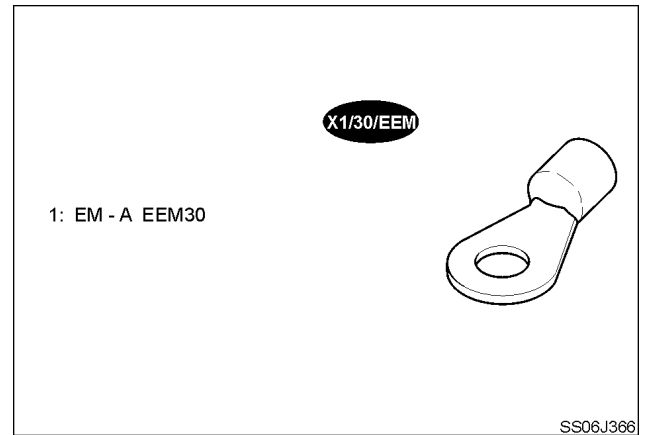

SS06J366 21

**X1/30/HEAT - Screw connection, roof PCB, heated windscreen, potential 30**

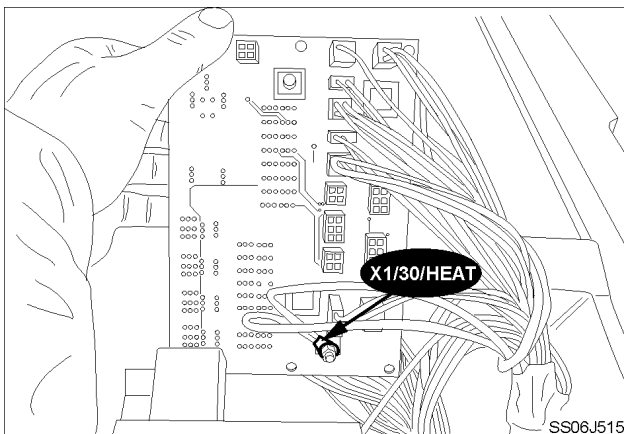

SS06J515 22

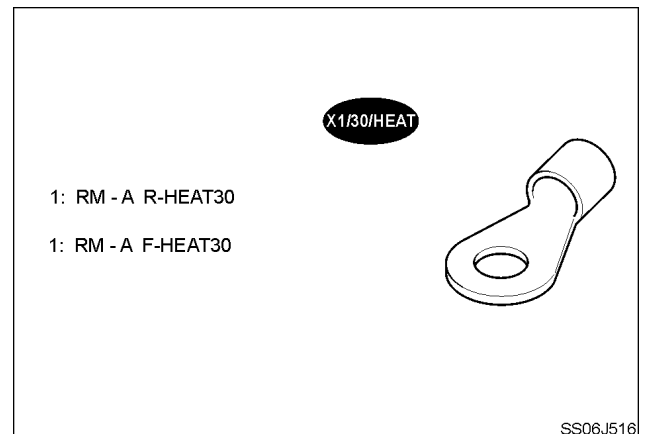

SS06J516 23

**X12/5 - Plug ICU**

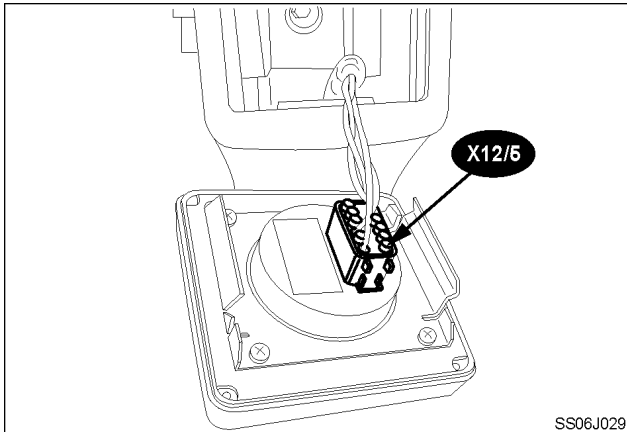

SS06J029 46

SS06J029

**Single battery**

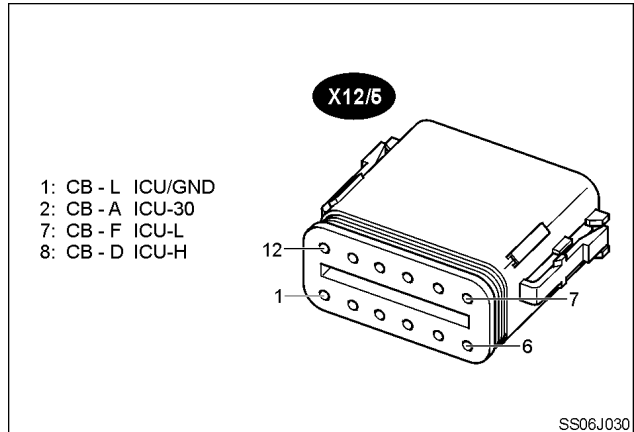

- 1: CB - L ICU/GND
- 2: CB - A ICU-30
- 7: CB - F ICU-L
- 8: CB - D ICU-H

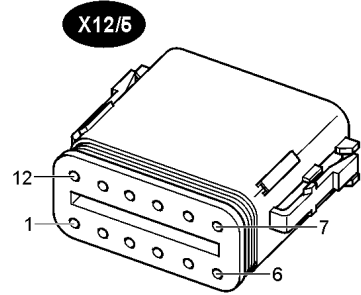

SS06J030 47

SS06J030

**Twin battery**

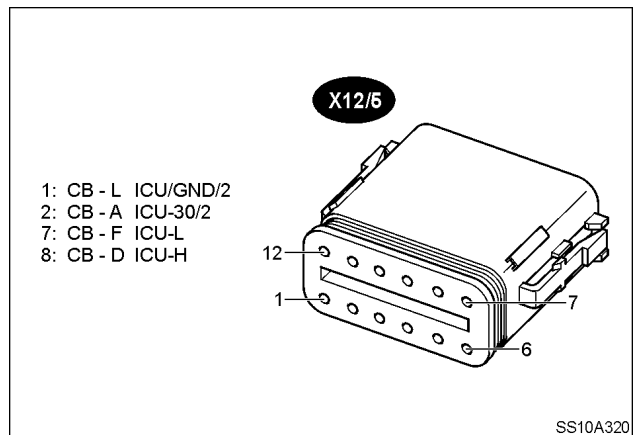

- 1: CB - L ICU/GND/2
- 2: CB - A ICU-30/2
- 7: CB - F ICU-L
- 8: CB - D ICU-H

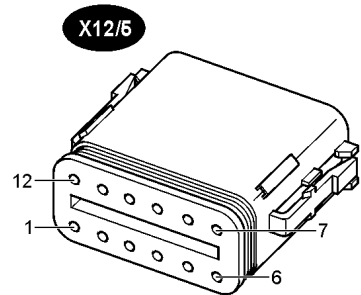

SS10A320 48

SS10A320

**X12/6 - Plug ICU, reverse drive unit**

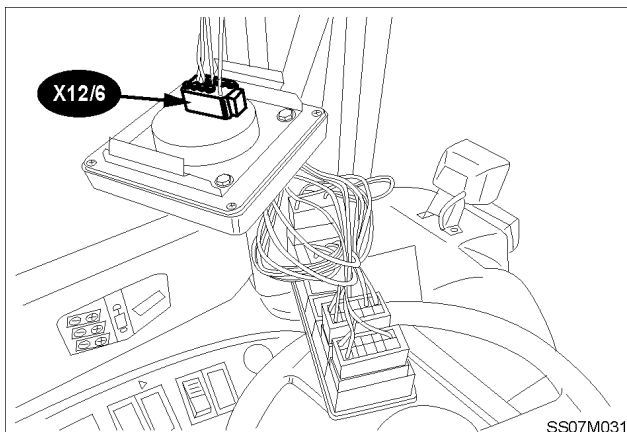

SS07M031 49

SS07M031

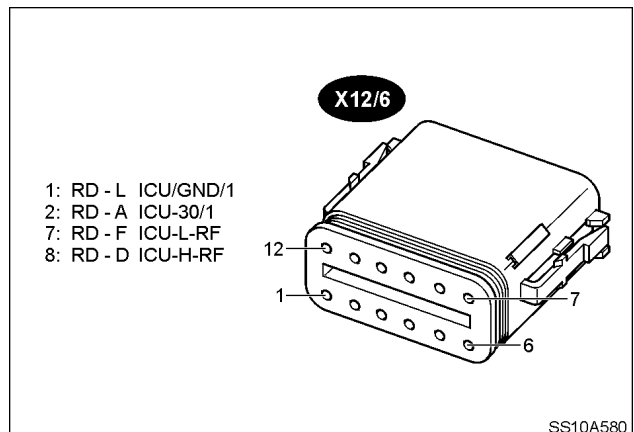

- 1: RD - L ICU/GND/1
- 2: RD - A ICU-30/1
- 7: RD - F ICU-L-RF
- 8: RD - D ICU-H-RF

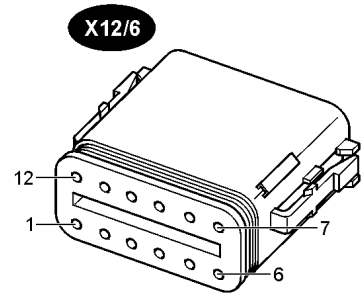

SS10A580 50

SS10A580

**X2/35 - Plug, licence plate light, left**

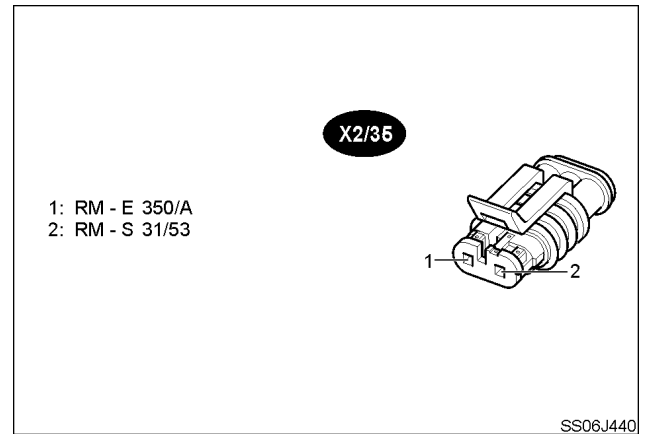
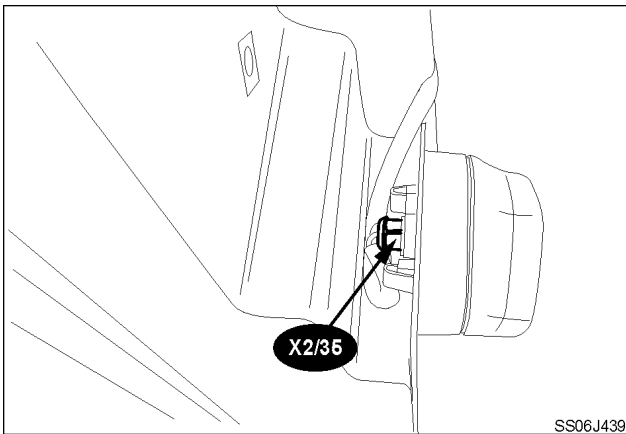

**X2/36 - Plug, sensor, fuel - temperature**

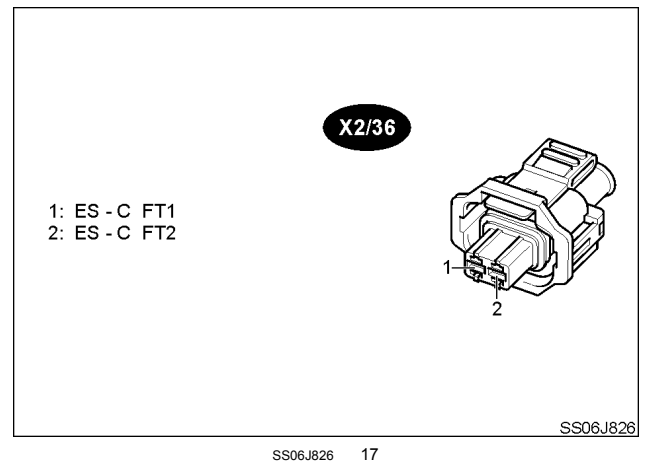
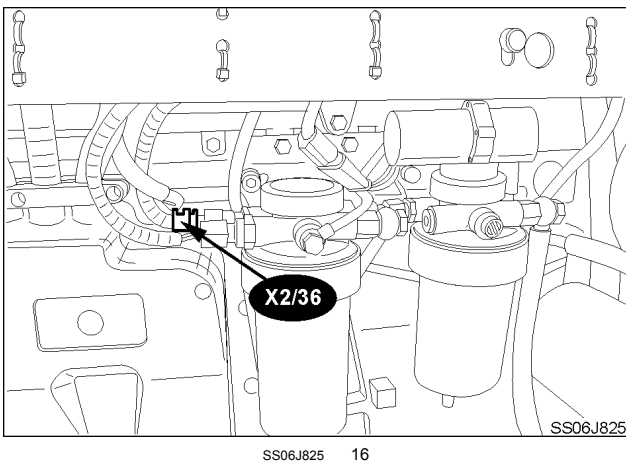

**X2/37 - Plug, work lamp, mudguard, left**

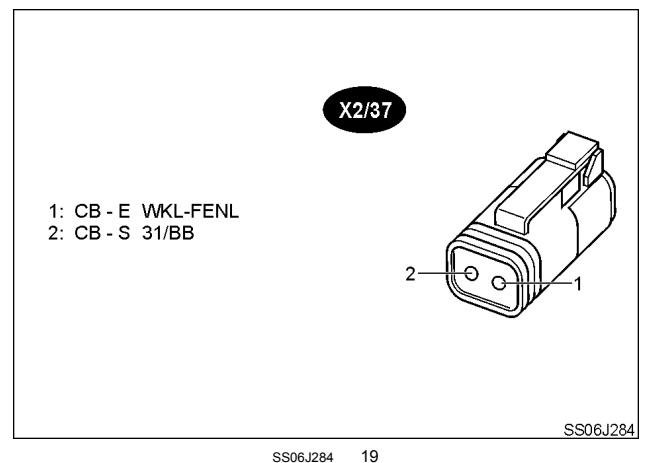
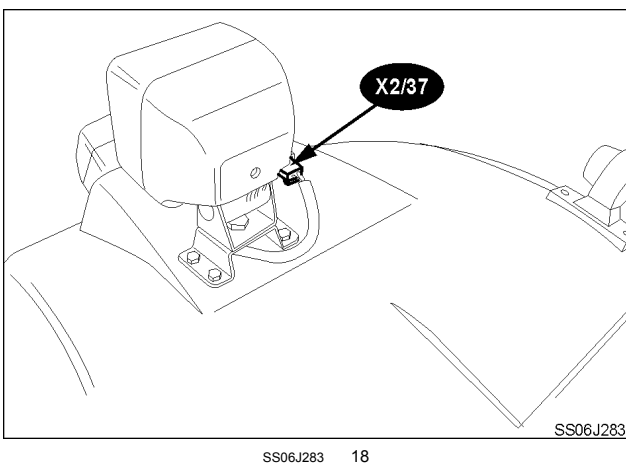

**X3/23 - Plug connection, steering angle sensor**

Twin battery

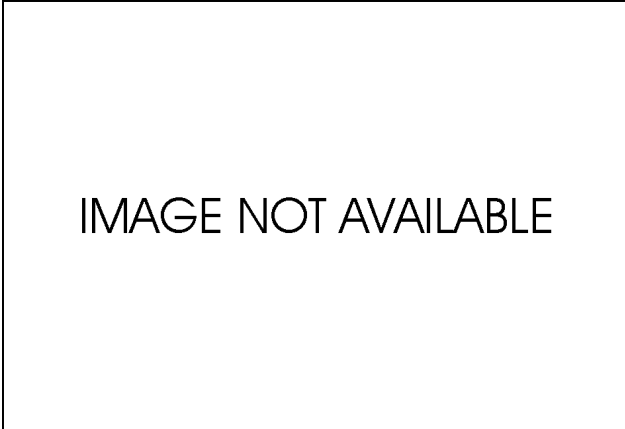

INA 50

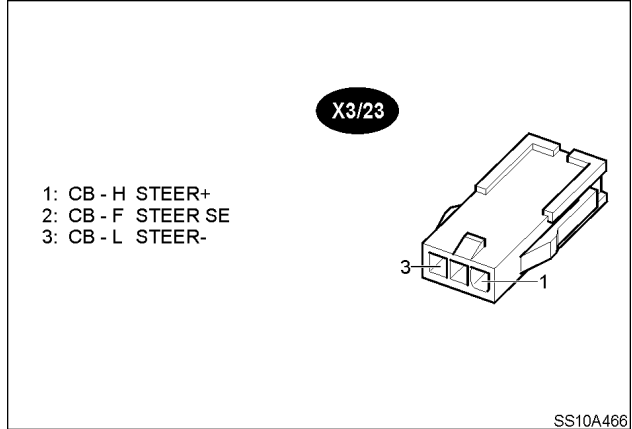

SS10A466 51

SS10A466

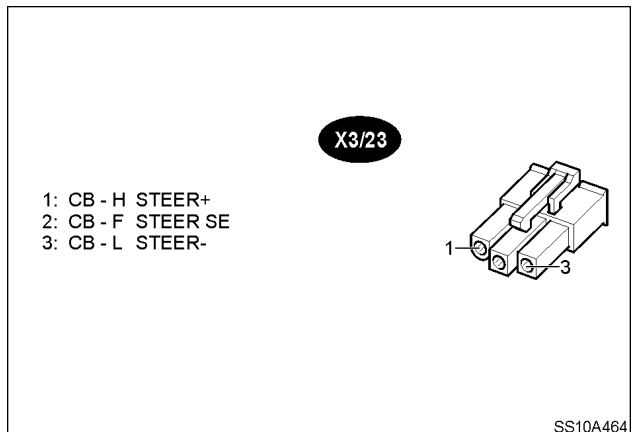

SS10A464 52

SS10A464

**X3/24 - Plug, steering angle sensor**

Twin battery

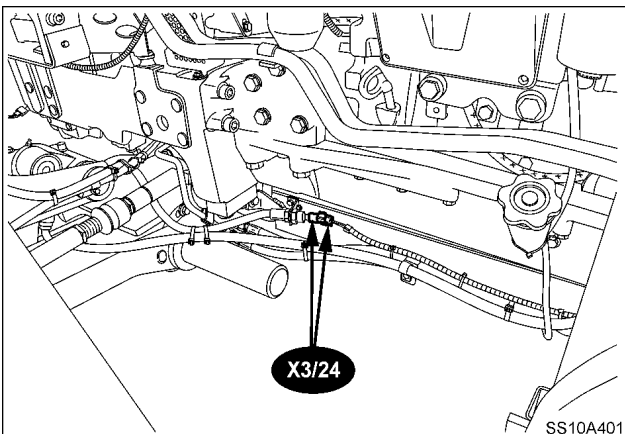

SS10A401 53

SS10A401

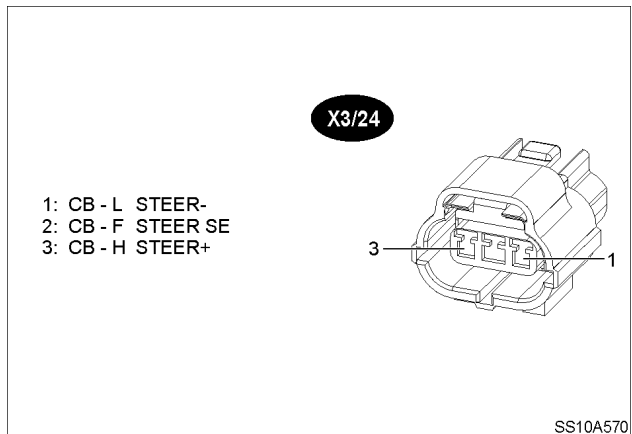

SS10A570 54

SS10A570

**X4/45 - Plug, central PCB, suspended front axle**

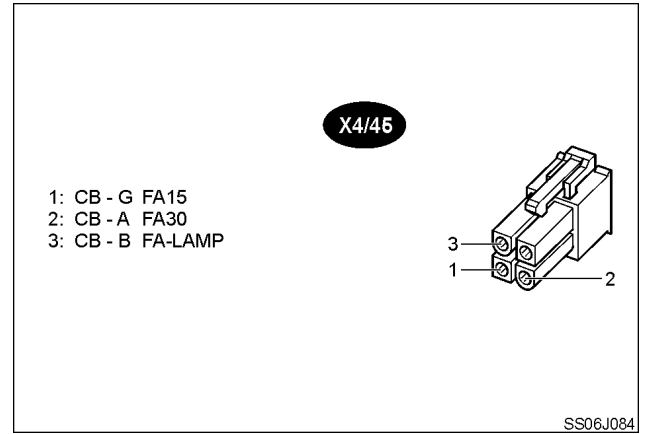
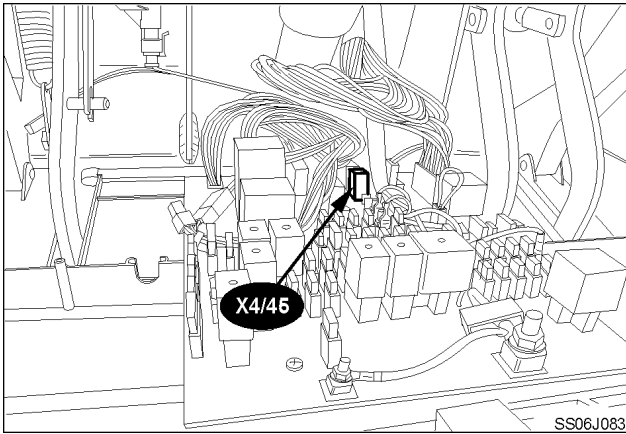

**X4/48 - Plug connection, wiring harness, roof - work lamp, rear right**

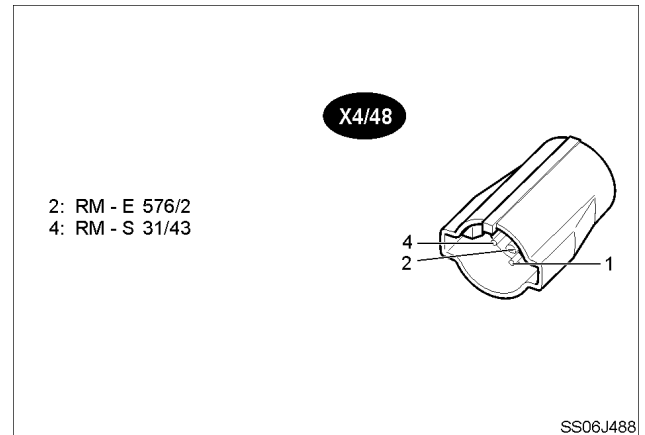
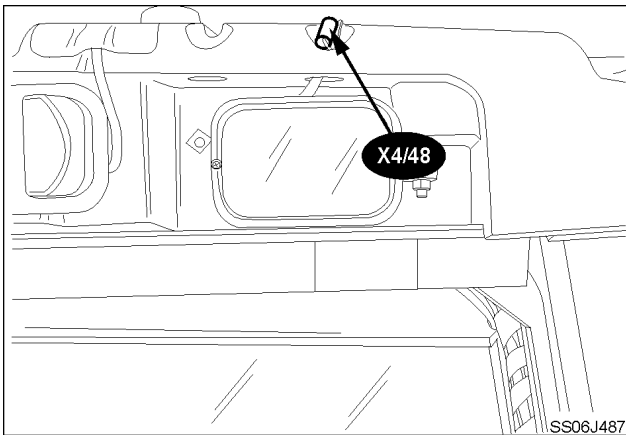

**X4/49 - Plug connection, wiring harness, roof - work lamp, rear left**

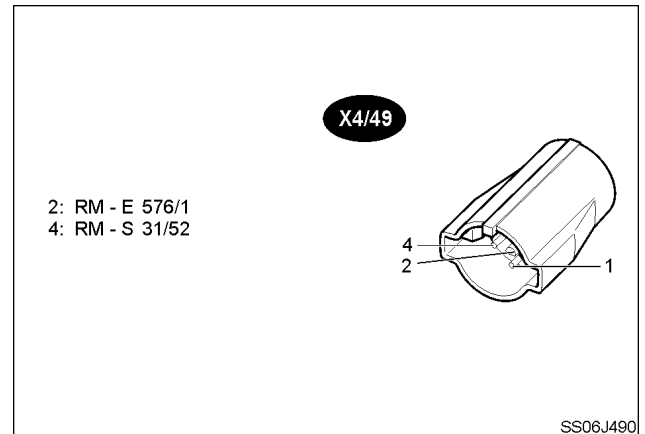
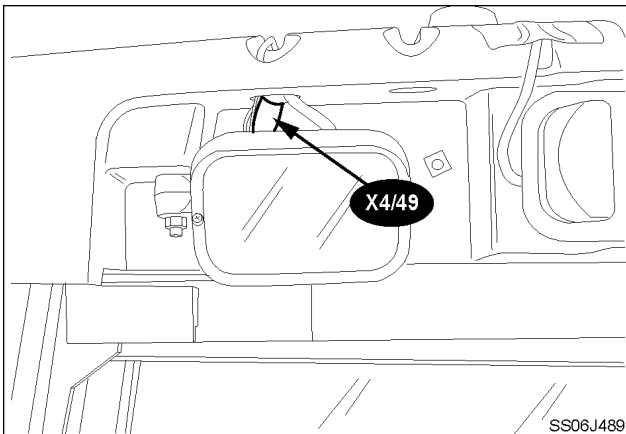

**X4/WIP-R - Plug, roof PCB, windscreen wiper, rear**

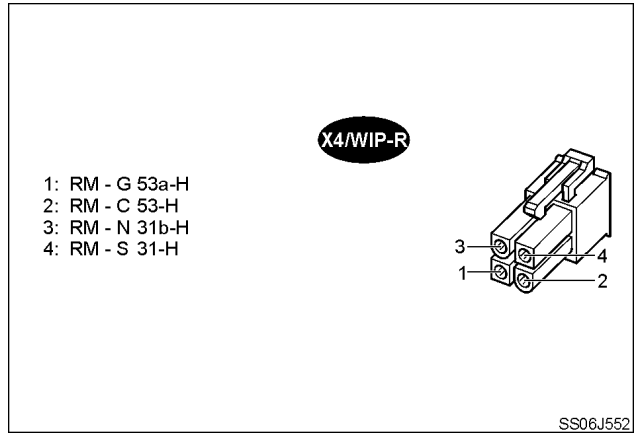
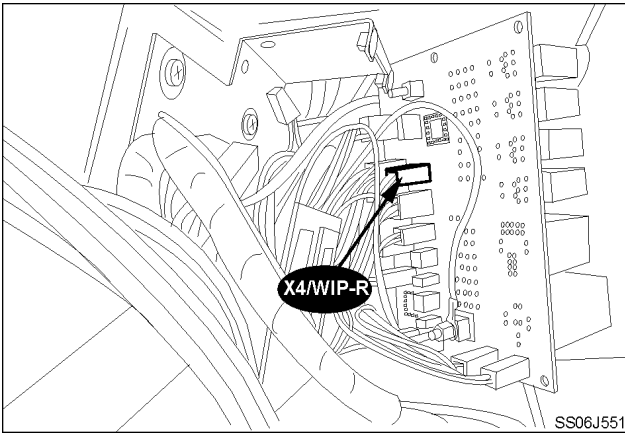

**X40/1 - Plug, fan motor**

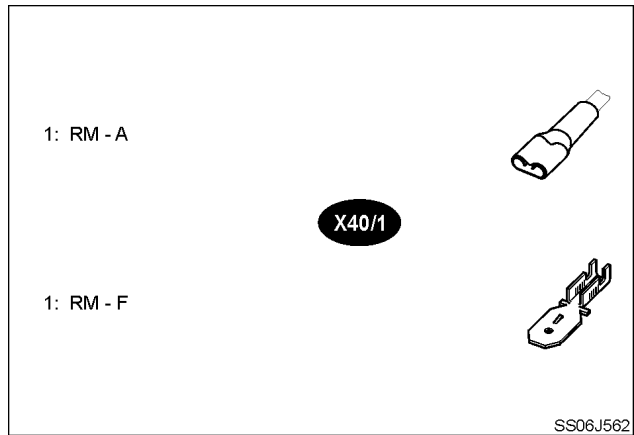
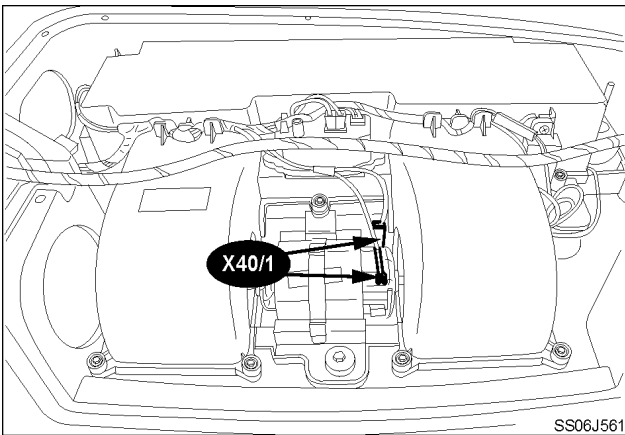

**X40/10 - Plug, electronics, fan levels**

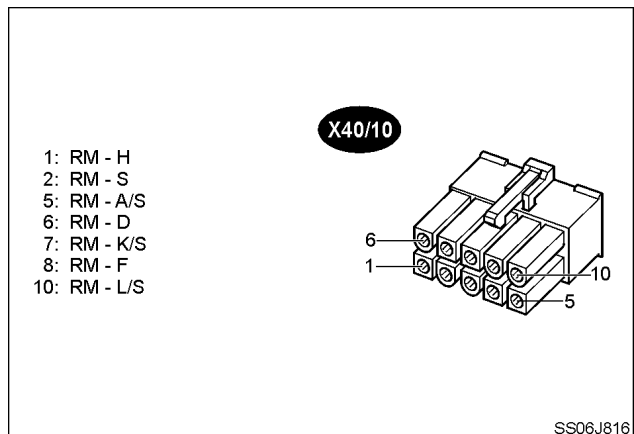
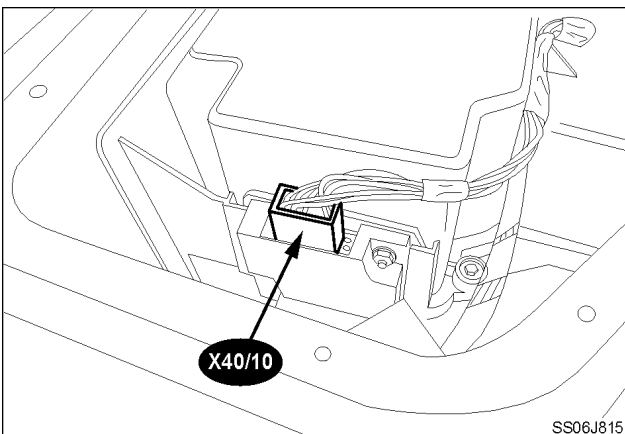

## Wire connectors - Component diagram 20

### Y10 - Plug, solenoid valve, differential lock

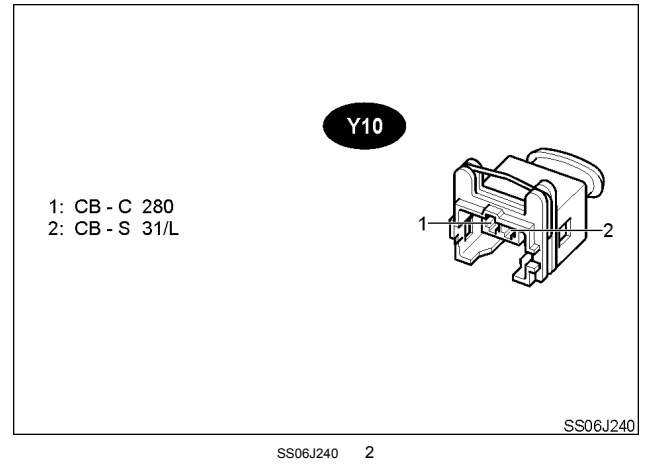
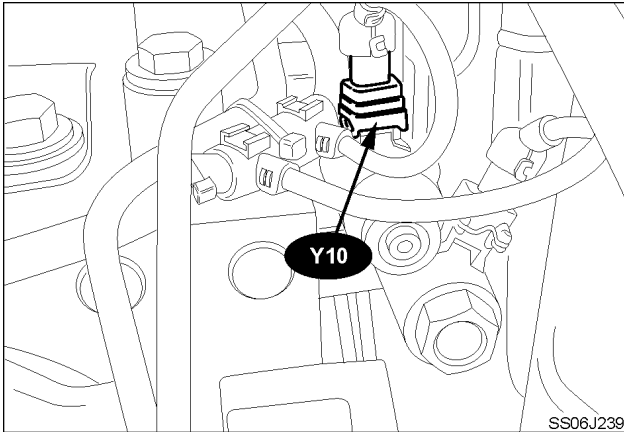

### Y11 - Plug, solenoid valve, brake oil cooling, right

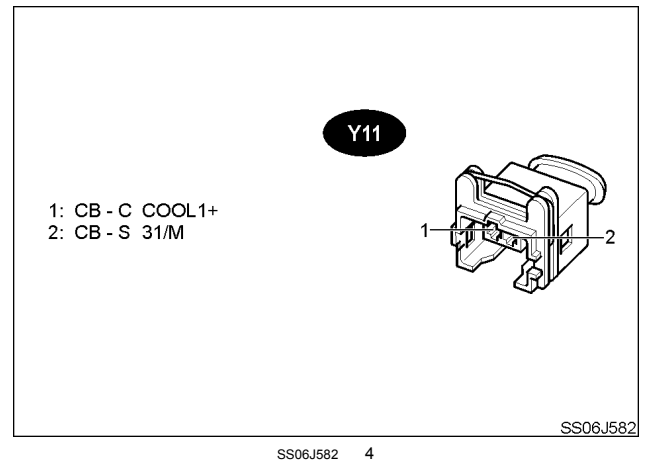
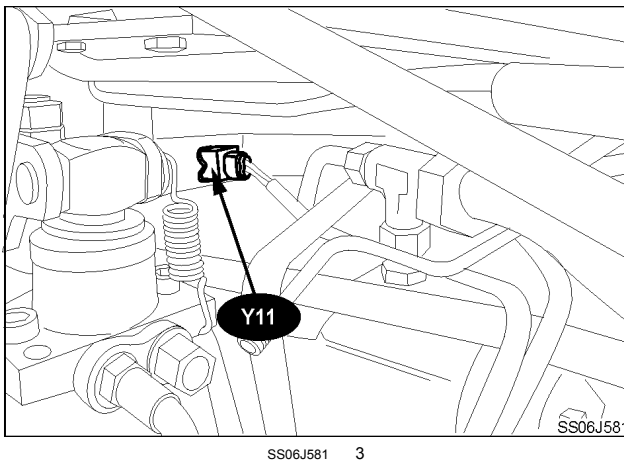

### Y12 - Plug, solenoid valve, brake oil cooling, left

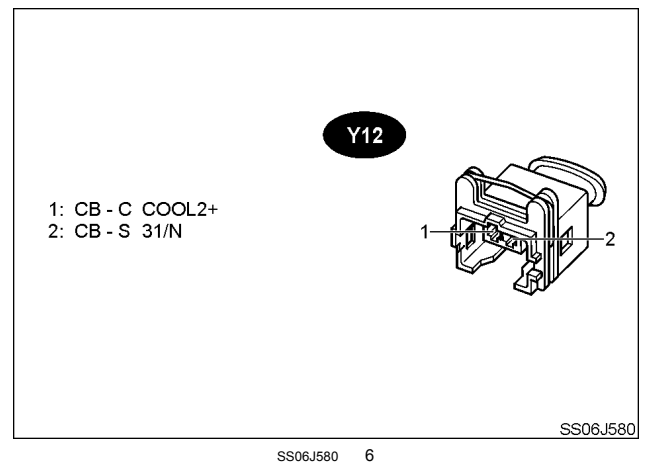
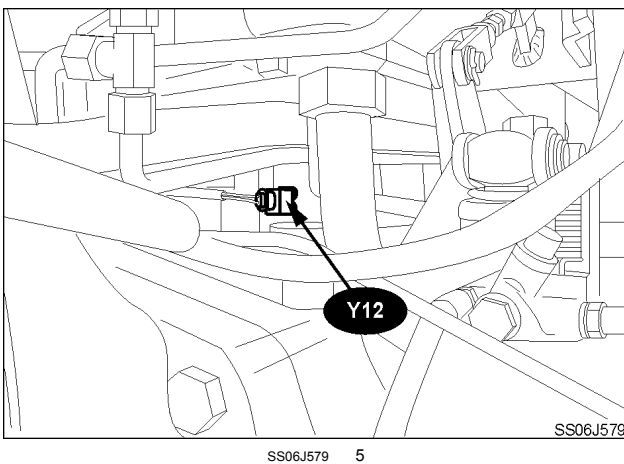

# Contents

---

## Electrical systems - 55

### Cab engine controls - 525

#### FUNCTIONAL DATA

Throttle hand control	
Overview .....	3
Accelerator potentiometer	
Overview .....	4
Overview .....	5

## Battery - General specification

### 12 V 160 Ah - single battery

Rated capacity for 20 hours of charging	160 Ah
Cold discharge test current in accordance with DIN (EN-CCA)	<b>630 A ( 1050 A)</b>
Voltage	<b>12 V</b>
Cells	6
Earth terminal	to body

### 12 V 95 Ah - twin battery

Rated capacity for 20 hours of charging	95 Ah
Cold discharge test current in accordance with DIN (EN-CCA)	<b>485 A ( 800 A)</b>
Voltage	<b>12 V</b>
Cells	6
Earth terminal	to body

### Table for determining output depending on temperature:

Temperature	Capacity of a fully charged battery
25 °C	100 %
-4.5 °C	82 %
-24 °C	64 %
-27.5 °C	58 %
-31 °C	50 %
-34.5 °C	40 %
-37.5 °C	33 %

### Table for determining charge state:

Charge state	Acid density at 15 °C	Acid density at 25 °C	Medium battery voltage
100 %	1.295	1.287	12.76 V
75 %	1.253	1.246	12.52 V
50 %	1.217	1.210	12.30 V
25 %	1.177	1.170	12.06 V
Discharged	1.137	1.130	11.84 V

## Water-In-Fuel sensor - Overview

### Water in fuel sensor B23

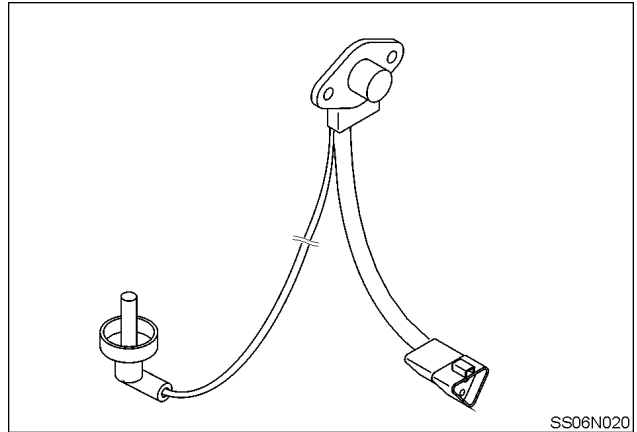
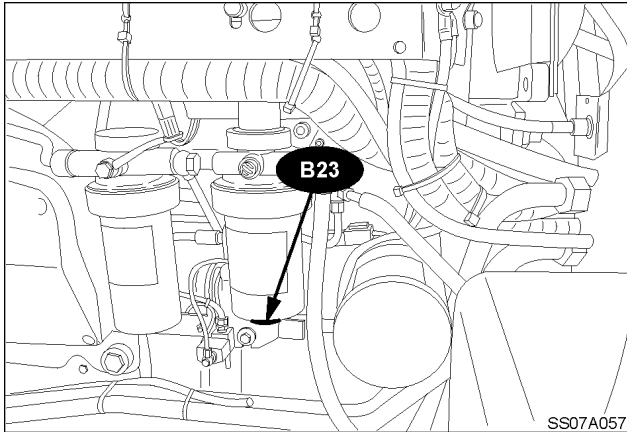

## Engine oil pressure sensor and switch - Overview

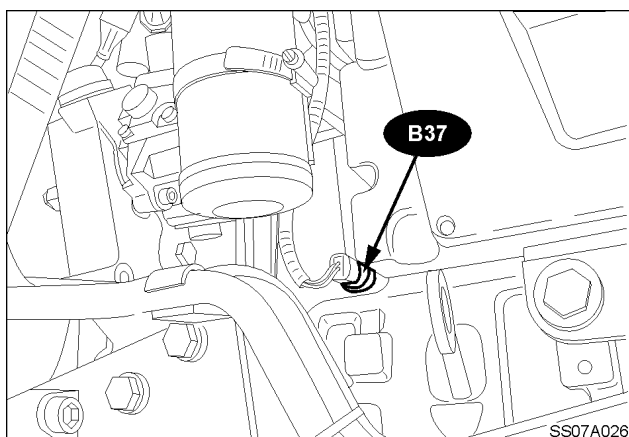

SS07A026 1

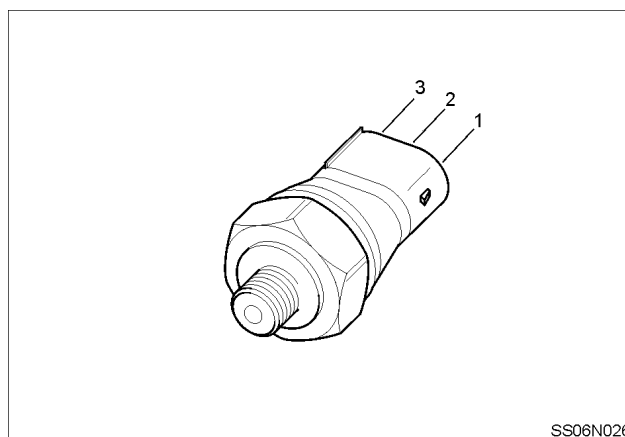

SS06N026 2

### Oil pressure sensor B37

Model	Pressure sensor
PIN 3 (supply)	5 V
PIN 1 (supply)	Earth
PIN 2 (signal)	0,5 - 4,5 V
Tightening torque	25 Nm

Pressure	Voltage	Pressure	Voltage
1.0 bar	0.5 V	6.5 bar	2.7 V
1.5 bar	0.7 V	7.0 bar	2.9 V
2.0 bar	0.9 V	7.5 bar	3.1 V
2.5 bar	1.1 V	8.0 bar	3.3 V
3.0 bar	1.3 V	8.5 bar	3.5 V
3.5 bar	1.5 V	9.0 bar	3.7 V
4.0 bar	1.7 V	9.5 bar	3.9 V
4.5 bar	1.9 V	10.0 bar	4.1 V
5.0 bar	2.1 V	10.5 bar	4.3 V
5.5 bar	2.3 V	11.0 bar	4.5 V
6.0 bar	2.5 V		

## Controller Area Network (CAN) data bus Passive terminator - Overview

The terminating resistors ensure correct transfer of data on the data bus. Without the terminating resistors the signal may be disturbed by electromagnetic impulses from outside and therefore no longer be reliable. Incorrect terminating resistor or faulty plug connections can cause communication problems.

Every data bus (vehicle bus, transmission bus or ISO BUS) is fitted with two terminating resistors.

The desired value of a terminating resistor is **120 Ω** (except for socket ISO bus **150 Ω**).

Terminating resistors are integrated both in control units, e.g. in the EEM (engine control unit) and in plug housing. The CANH and CANL signal wires are linked in parallel by the terminating resistors. The slope resistance between the two data bus wires is therefore **60 Ω +/- 10 %** for the vehicle bus and transmission bus and **66,66 Ω +/- 10 %** for the ISO bus. If a terminating resistor is separated from the data bus (vehicle bus, transmission bus), the resistance is **120 Ω**. If a terminating resistor is separated from the ISO-BUS, the resistance is **120 Ω** or **150 Ω**.

**NOTE:** At least one terminating resistor is necessary for the correct signal level to be reached.

The data bus generally works with only one terminating resistor without problems. The second terminating resistor simply provides additional system security. When operating with only one terminating resistor, data transfer may be temporarily disturbed, especially in the area of radio waves (radio, mobile telephone, radar etc.).

### Vehicle bus

	Plug / PIN	Resistance
EEM	X89/1 (34 - 35)	<b>120 Ω +/- 10 %</b>
ARU	X6/4 (5 - 6)	<b>120 Ω +/- 10 %</b>

### Transmission bus

	Plug / PIN	Resistance
FMGR	A4/3 (17 - 18)	<b>120 Ω +/- 10 %</b>
SGR	X16/21 (1 - 2)	<b>120 Ω +/- 10 %</b>

### EEM ID module bus

	Plug / PIN	Resistance
EEM	X89/1 (52 - 53)	<b>120 Ω +/- 10 %</b>
ID module	X4/4 (2 - 3)	<b>120 Ω +/- 10 %</b>

### ISO BUS

	Plug / PIN	Resistance
	X3/85 (A - B)	<b>120 Ω +/- 10 %</b>
Plug Socket end	X4/86 (2 - 3)	<b>150 Ω +/- 10 %</b>

### Autoguidance

	Plug / PIN	Resistance
	X3/86 (A - B)	<b>120 Ω +/- 10 %</b>

Electrical system - Electrical schema (55.000)

Electrical system - Electrical schema (55.000)

Electronic module - Overview (55.640)

## Transmission control system - Replace (controller for hydrostat)

### Prior operation:

Carry out preliminary work — see **Continuously Variable Transmission (CVT) - Prepare (21.504)**.

1. Undo the screws and remove the controller.

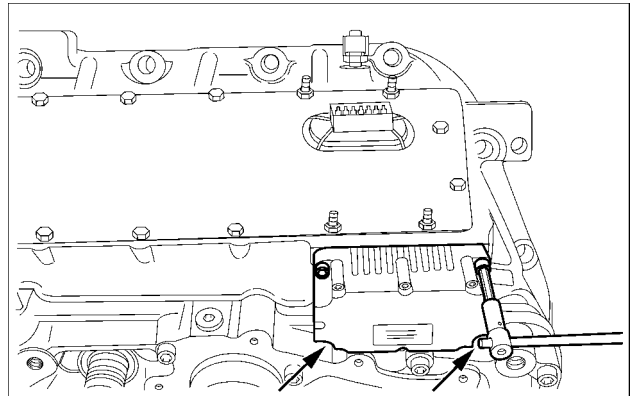

2. Disconnect the plug.
3. Clean the sealing surfaces.
4. Apply silicone sealant to the flange surface and connect the plug.
5. Then assemble the controller. Spray the screws with **LOCTITE® 243**, fit and tighten to **9.5 Nm (7.0 lb ft)**.

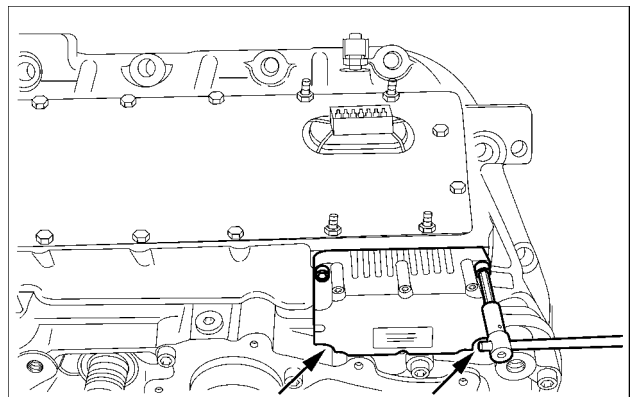

### Next operation:

Carry out the preliminary work in the reverse order — see **Continuously Variable Transmission (CVT) - Prepare (21.504)**.

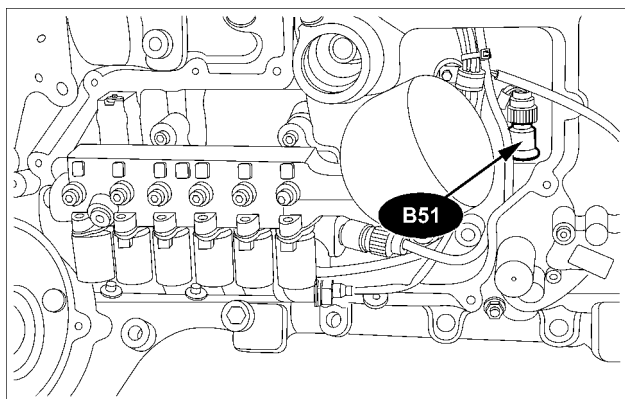

SS12C292 3

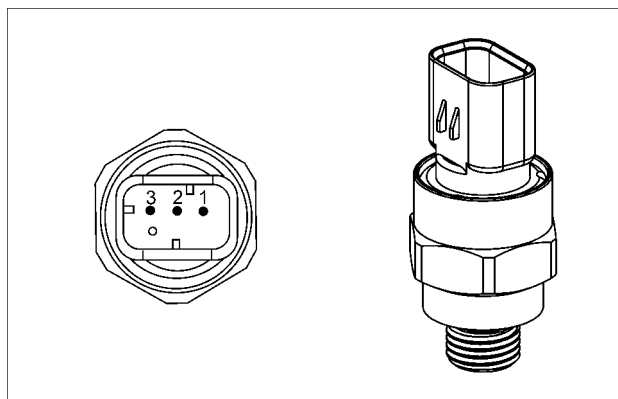

SS12C293 4

**Lubrication pressure sensor B51 (i2S)**

Screw-in thread	M14x1.5
Measuring range	<b>0 - 10 bar (0 - 145 psi)</b>
PIN 1	Ground
PIN 2 (metric signal ratio)	
at 0 bar (0 psi)	<b>0.5 V</b>
at 10 bar (145 psi)	<b>4.5 V</b>
PIN 3 (supply)	<b>5 V</b>
Accuracy	
-40 - 0 °C (-104 - 32 °F)	Max. ± 2 % *
0 - 90 °C (32 - 194 °F)	Max. ± 2 % *
Current draw	Max. <b>10 mA</b>
Load resistance	<b>1 k Ω (5 k Ω)</b>
Operating temperature	<b>-40 - 125 °C (-104 - 257 °F)</b>
Insulation resistance	> <b>100 k Ω</b>
Tightening torque	<b>20 Nm (14.8 lb ft)</b>
* relative to the supply voltage	

**NOTE:** Convert the sensors using the Electronic System Tool (EST).

## Suspended axle sensor Suspension position sensor - Overview

T7510 Vorderachse 20.25S, T7520 Vorderachse 20.25S, T7530 Vorderachse 20.25S, T7540, T7550

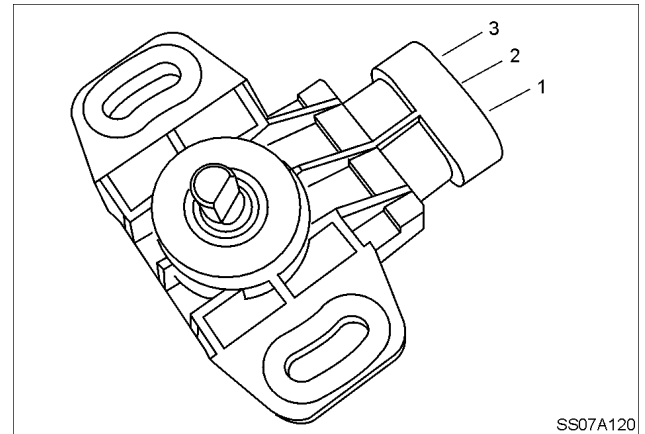
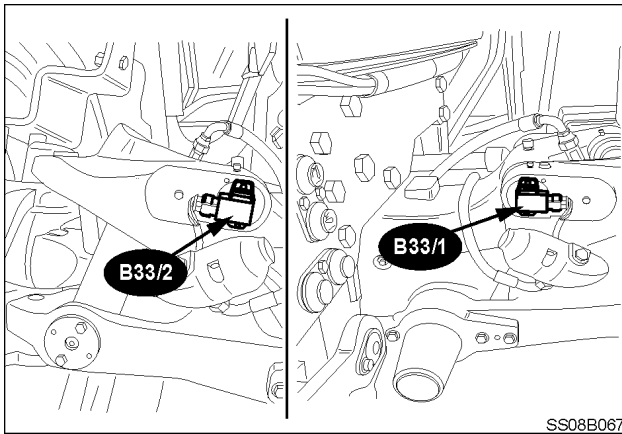

### Angle of rotation sensor B33/1, B33/2

PIN 2 (E-Box supply)	<b>12 V</b>
PIN 1 (E-Box supply)	Ground
PIN 3	Signal (mA)
Signal, axle 20.25S	
Vehicle lowered	<b>6,0 ±0,5 mA</b>
Vehicle raised	<b>16,0 ±0,5 mA</b>
Signal, axle 20.29S	
Vehicle lowered	<b>8,0 ±0,5 mA</b>
Vehicle raised	<b>16,0 ±0,5 mA</b>

**NOTE:** The adjustment is made by turning the sensor.

# Contents

---

## Electrical systems - 55

### Rear Power Take-Off (PTO) control system - 048

#### FUNCTIONAL DATA

##### Power Take-Off (PTO) speed sensor

Overview .....	3
----------------	---



## **Electrical systems - 55**

### **Cab brake controls - 519**

**T7510  
T7520  
T7530  
T7540  
T7550**

# Index

---

## Electrical systems - 55

### Cab controls - 512

Multi-Function Handle (MFH) - Overview Finger wheel Multi Controller ..... 3

# Index

---

## Electrical systems - 55

### Steering control system - 047

Steering position sensor - Calibrate (steering angle sensor B41) .....	8
Steering position sensor - Electrical adjust (steering angle sensor B41) .....	6
Steering position sensor - Overview (Steering angle sensor) .....	3
Steering position sensor - Replace (steering angle sensor B41) .....	4

## Front hitch link position sensor - Calibrate

**NOTE:** Prior to calibration the external button must be configured to the respective **AUX** otherwise calibration and management functions are not possible.

The sensor requires calibration the first time only or if the sensor signal is interrupted for >3 seconds and the starter switch is switched to the "OFF" position. Otherwise recalibration takes place automatically.

- The sensor should only be operated up to a signal value of **25 - 75 %** for the supply voltage ( **8 V**). If there is a signal voltage short circuit to positive (> **6,6 V**) or ground (< **1,8 V**) the error codes ECCU3 - 72 or 73 are shown.
- Move the power lift to the middle position using the joystick (A29).
- Turn the starter switch to the "OFF" position.
- Disconnect the angle of rotation sensor for the front power lift (B19).
- Turn the starter switch to the "ON" position for at least 5 seconds.
- Turn the starter switch to the "OFF" position.
- Connect the angle of rotation sensor for the front power lift (B19).
- Turn the starter switch to the "ON" position.

### Calibration process

- Adjust the oil flow for the respective control unit ( **AUX 1**) < **50 %**.
- Move the power lift to the top position using the joystick and hold it in the "Raise" position for 5 seconds using the stick.
- Move the power lift to the bottom position using the joystick and hold it in the "Lower" position for 5 seconds using the stick.

### Calibration check

- Press the front power lift management button (AUX keypad), the power lift display automatically appears in the performance monitor . Move the power lift to the bottom position, the value displayed is **0 %**, then move the power lift to the top position, the display must show **100 %**.

**NOTE:** If the calibration fails it could be that the signal fluctuated too much in the top or bottom position. In both end positions the signal must fluctuate less than **0,024 V** for at least 1 second. Due to the relatively small fluctuation range it may be necessary to perform a second calibration sequence.

## Instrument cluster Analog-Digital Instrument Cluster (ADIC) - Dynamic description of the display instruments

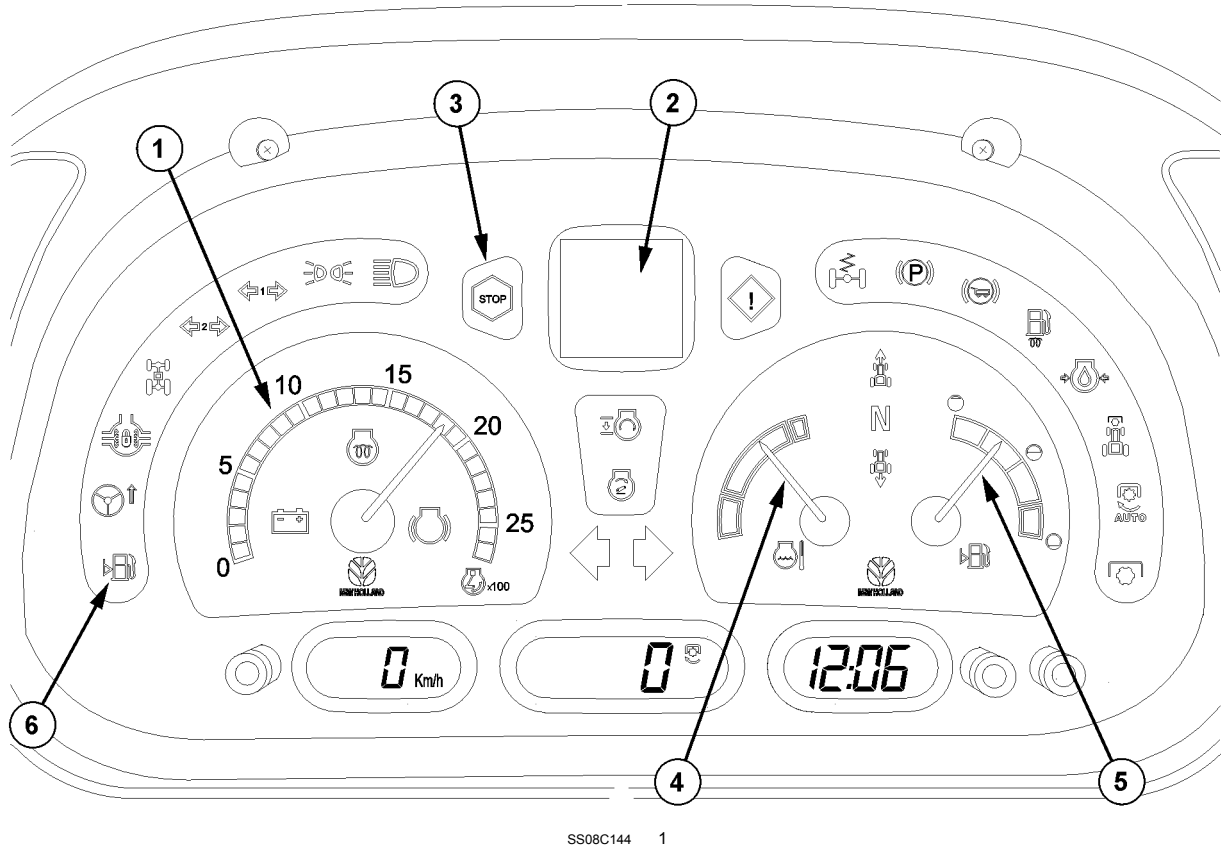

SS08C144 1

### Engine speed display

The engine speed (1) is displayed in revolutions per minute x 100.  
The engine speed is provided by the engine control unit (speed sensor, engine B20) via CAN BUS for the ADIC.

### Coolant temperature display

The coolant temperature display (4) is split into three areas:

Blue field	Temperature too low
Normal range	Ideal operating temperature
Red field	temperature too high

The coolant temperature is provided by the engine control unit (temperature sensor, engine B22) via CAN BUS for the ADIC.

If the temperature rises above **110 °C**, the DMD shows the symbol for temperature, the red warning lamp (3) starts to flash and an audible alarm (critical warning!) sounds — see **Engine and crankcase - Dynamic description Automatic engine shutdown (10.001)**.

### Fuel display – fill level

The fuel display – fill level (5) is split into the ranges EMPTY, RESERVE (red area), HALF-FULL and FULL. If the pointer reaches the red area, the indicator light (6) comes on.  
The tank capacity is still approx. 1/6 of the total volume.

### Programming the maintenance indicator

This function allows two maintenance interval displays to be programmed. The procedure for setting "LIGHT" and "HEAVY" maintenance intervals is the same and will therefore not be described twice.

Factory setting:

"LIGHT" 250 operating hours

"HEAVY" 250 operating hours

- Turn the starter switch to the "ON" position; within 5 sec. depress the "ENTER" button (4) and the "HOME" button (2) simultaneously for 10 sec.
- Press the "SCROLL" buttons (1) or (3) until the desired menu "SERVICE" appears.

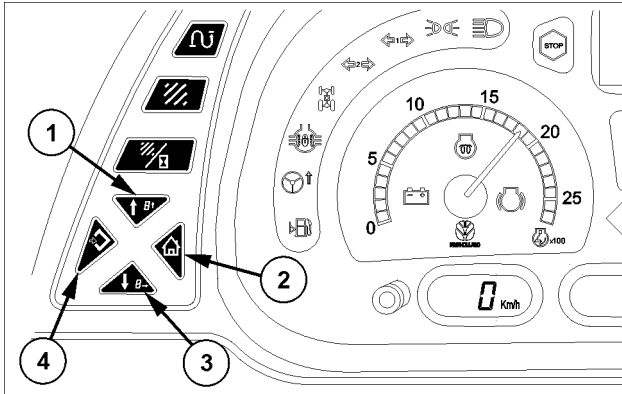

SS08C140 14

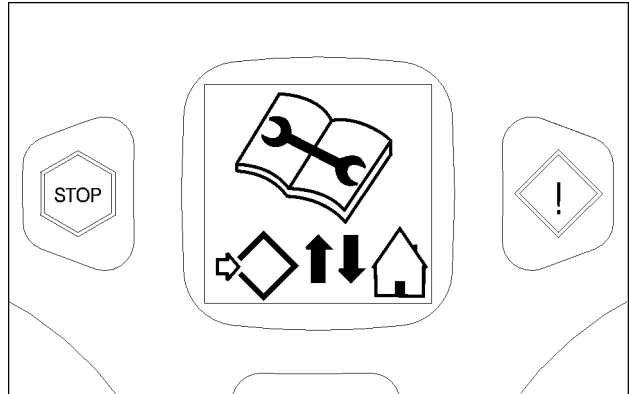

SS07N024 15

- Press the "ENTER" button (4) and use the « SCROLL » buttons (1) or (3) to select the "LIGHT" or "HEAVY" display.

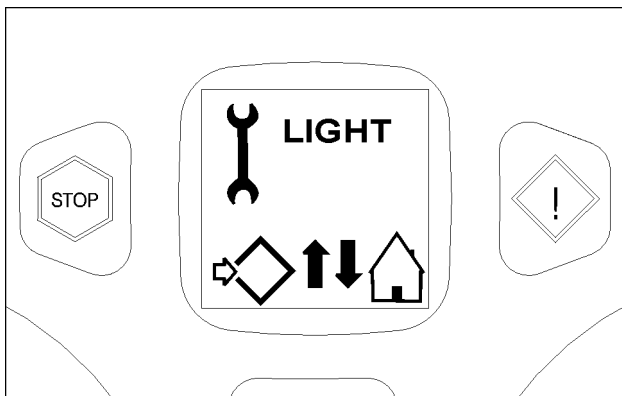

SS07N025 16

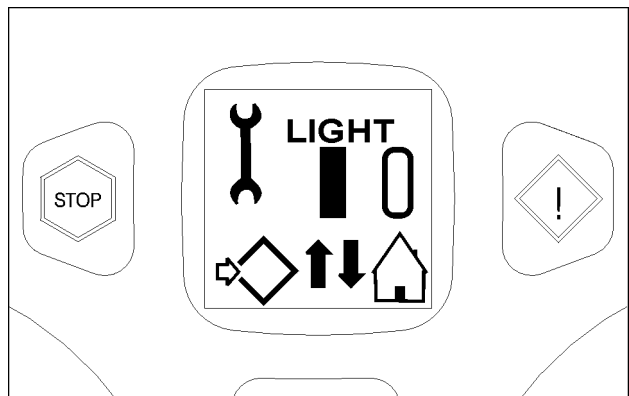

SS07N026 17

- Press the "ENTER" button (4) again. A flashing cursor appears on the DMD at the first position of the input field.
- Use the "SCROLL" button (1) to enter the desired figure.
- Use the "SCROLL" button (3) to move to the next position in the input field.
- Use the "SCROLL" button (1) to again enter the desired figure.
- Follow the same procedure to enter the third and fourth figure.
- To save the setting press the « ENTER » button (4).
- Use the "HOME" button (2) to exit the menu.

**NOTE:** The service warning can be switched off by setting the service interval to "0" operating hours.

### Radar sensor

- Turn the starter switch to the "ON" position; within 5 sec. depress the « ENTER » button (4) and the "HOME" button (2) simultaneously for 10 sec.
- Press the « SCROLL » buttons (1) or (3) until the desired menu "WHEEL / RADAR" appears.

## Electrical systems - FAULT CODES

Message	Description	Controller
252	Fuel temperature sensor, signal voltage too high	EEM3
253	Fuel temperature too high	EEM3
261	Fuel temperature sensor, no signal	EEM3
263	Rail pressure sensor — signal voltage too low	EEM3
264	Rail pressure sensor — signal voltage too high	EEM3
265	Rail pressure too high	EEM3
266	Rail pressure, no signal	EEM3
269	Engine RPM, signal faulty	EEM3
271	Engine RPM sensor signal faulty	EEM3
272	Engine RPM sensor signal interrupted	EEM3
273	Engine RPM sensor connections inverted	EEM3
276	Pressure drop in intake system during engine start-up too high	EEM3
281	Camshaft position sensor signal faulty	EEM3
282	Camshaft position sensor signal interrupted	EEM3
283	Camshaft position sensor connections inverted	EEM3
284	Camshaft position sensor signal implausible	EEM3
291	Fuel feed pressure sensor, signal voltage too low	EEM3
292	Fuel feed pressure sensor, signal voltage too high	EEM3
293	Fuel feed pressure sensor, no signal	EEM3
311	Injector 1 — solenoid valve short circuit to earth	EEM3
312	Injector 1 — solenoid valve short circuit to + supply	EEM3
313	Injector 1 — solenoid valve circuit open	EEM3
314	Injector 1 — solenoid valve open too long	EEM3
315	Injector 1 — solenoid valve error	EEM3
321	Injector 5 — solenoid valve short circuit to ground	EEM3
322	Injector 5 — solenoid valve short circuit to + supply	EEM3
323	Injector 5 — solenoid valve circuit open	EEM3
324	Injector 5 — solenoid valve open too long	EEM3
325	Injector 5 — solenoid valve error	EEM3
331	Injector 3 — solenoid valve short circuit to earth	EEM3
332	Injector 3 — solenoid valve short circuit to + supply	EEM3
333	Injector 3 — solenoid valve circuit open	EEM3
334	Injector 3 — solenoid valve open too long	EEM3
335	Injector 3 — solenoid valve error	EEM3

CLICK HERE TO **DOWNLOAD** THE COMPLETE MANUAL

- Thank you very much for reading the preview of the manual.
- You can download the complete manual from: [www.heydownloads.com](http://www.heydownloads.com) by clicking the link below



- Please note: If there is no response to CLICKING the link, please download this PDF first and then click on it.

CLICK HERE TO **DOWNLOAD** THE COMPLETE MANUAL