

# SERVICE MANUAL

**T7.175 / T7.190 / T7.210**

**T7.175 AutoCommand™ / T7.190 AutoCommand™**

**T7.210 AutoCommand™ / T7.225 AutoCommand™**

**TIER 4B (FINAL)**

Tractor

Part number 47936463

English

November 2015

AGRICULTURE

CLICK HERE TO **DOWNLOAD** THE COMPLETE MANUAL

- Thank you very much for reading the preview of the manual.
- You can download the complete manual from: [www.heydownloads.com](http://www.heydownloads.com) by clicking the link below



- Please note: If there is no response to CLICKING the link, please download this PDF first and then click on it.

CLICK HERE TO **DOWNLOAD** THE COMPLETE MANUAL

31. A. Connect the NOx amplifier electrical connector **(1)**.  
B. Connect the fan electrical connector **(2)**.

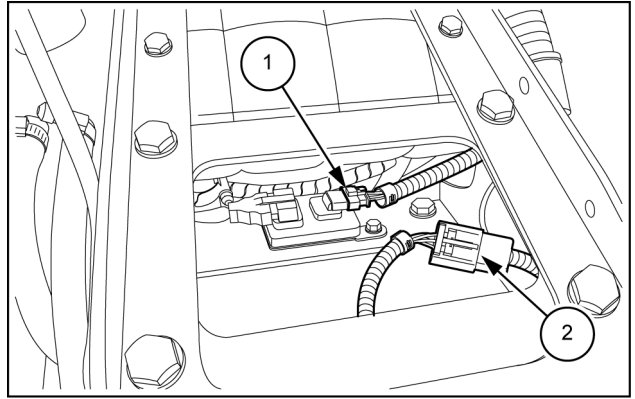

BAIL13TR01681AB 30

32. 1. Connect the cab heater hose.  
2. Connect the main harness electrical connector.

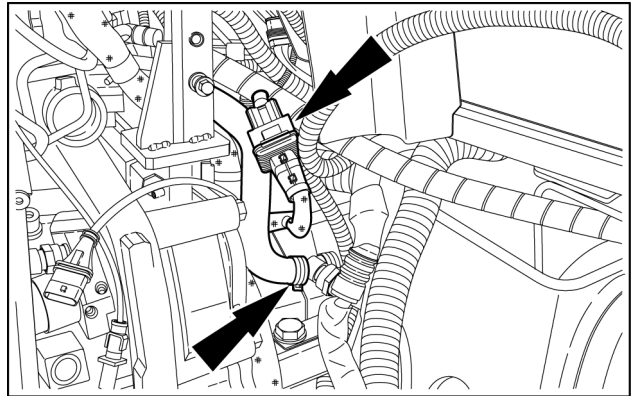

BAIL13TR01680AB 31

33. Install the A/C pipe retaining clamp.

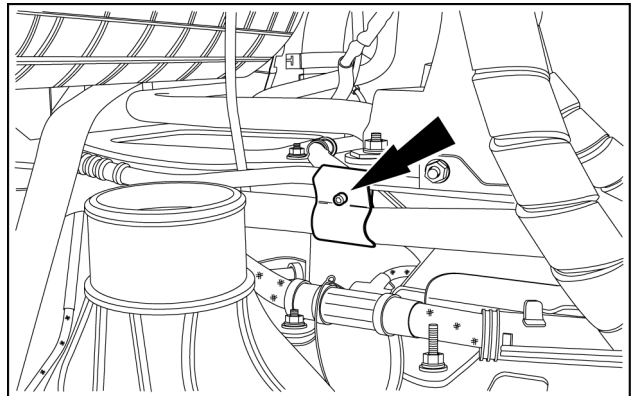

BAIL13TR01679AB 32

34. Connect the A/C pipes.

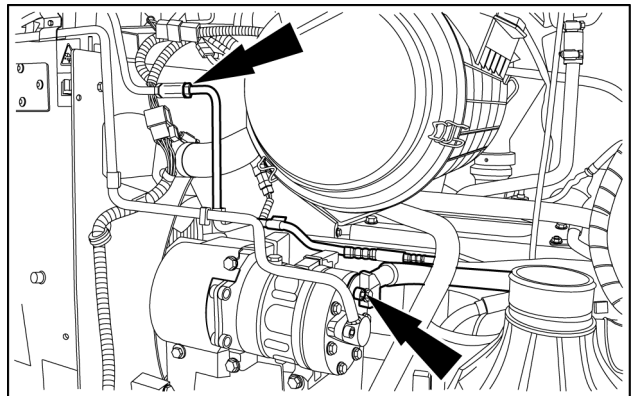

BAIL13TR01678AB 33

## Fuel tank - Install

T7.175 AutoCommand™	ANZ Anti-lock Brake System (ABS) - without ABS --- APAC Anti-lock Brake System (ABS) - without ABS --- MEA Anti-lock Brake System (ABS) - without ABS
T7.175	ANZ Anti-lock Brake System (ABS) - without ABS --- APAC Anti-lock Brake System (ABS) - without ABS --- MEA Anti-lock Brake System (ABS) - without ABS
T7.190 AutoCommand™	ANZ Anti-lock Brake System (ABS) - without ABS --- APAC Anti-lock Brake System (ABS) - without ABS --- MEA Anti-lock Brake System (ABS) - without ABS
T7.190	ANZ Anti-lock Brake System (ABS) - without ABS --- APAC Anti-lock Brake System (ABS) - without ABS --- MEA Anti-lock Brake System (ABS) - without ABS
T7.210 AutoCommand™	ANZ Anti-lock Brake System (ABS) - without ABS --- APAC Anti-lock Brake System (ABS) - without ABS --- MEA Anti-lock Brake System (ABS) - without ABS
T7.210	ANZ Anti-lock Brake System (ABS) - without ABS --- APAC Anti-lock Brake System (ABS) - without ABS --- MEA Anti-lock Brake System (ABS) - without ABS
T7.225 AutoCommand™	ANZ Anti-lock Brake System (ABS) - without ABS --- APAC Anti-lock Brake System (ABS) - without ABS --- MEA Anti-lock Brake System (ABS) - without ABS

### **⚠ WARNING**

**Personal Protective Equipment (PPE) required. When assembling, operating, or servicing the machine, wear protective clothing and PPE necessary for the particular procedure. Some PPE that may be necessary includes protective shoes, eye and/or face protection, hard hat, heavy gloves, filter mask, and hearing protection.**

**Failure to comply could result in death or serious injury.**

W0353A

**NOTE:** Make sure that all openings are sealed. Use new blanking caps.

1. Wait 3 minutes after ignition key-off before commencing any repairs to Selective Catalytic Reduction (SCR) components.

### Right-hand fuel tank

2. With the aid of an assistant or trolley jack install the right-hand fuel tank.

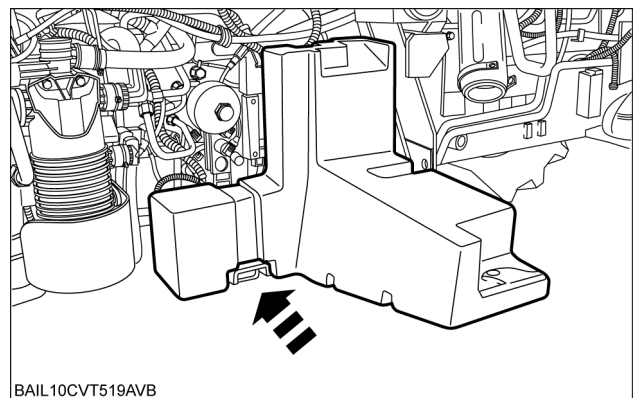

BAIL10CVT519AVB 1

## Exhaust manifold - Install

### Prior operation:

#### Exhaust manifold - Remove (10.254)

1. Install the exhaust manifold (2) with a new gasket onto the cylinder head and secure with the retaining bolts (1).
2. Torque the bolts (1) to the following specifications:
  - 4 cylinder engines – **55 N·m (41 lb ft)**
  - 6 cylinder engines – **55 N·m (41 lb ft)**

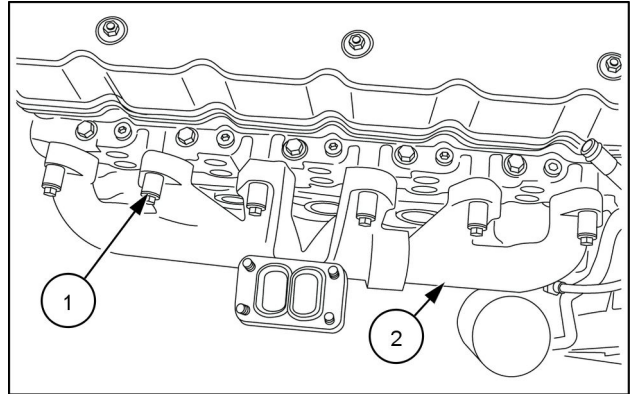

NHIL13ENG0625AA 1

12. A. Connect the electrical connector (1).
- B. Install the condenser pivot bolt (2).
- C. Tighten the over-centre catches (3).

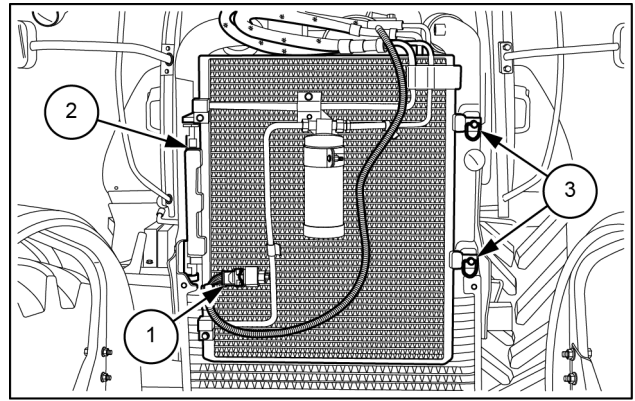

BAIL13TR01779AB 12

13. 1. Connect the radiator top hoses.
2. Connect the charge air cooler pipe.

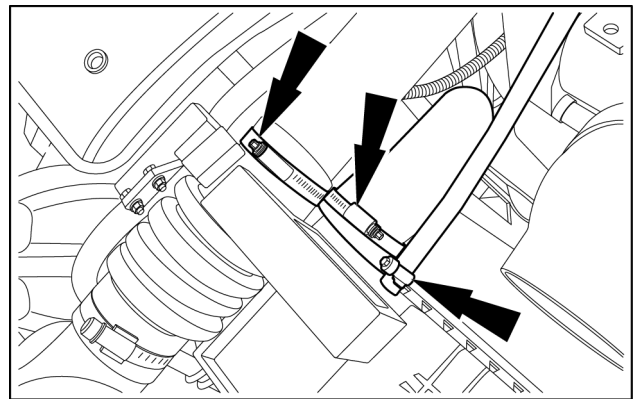

BAIL13TR01778AB 13

14. Install the radiator upper retaining bracket.

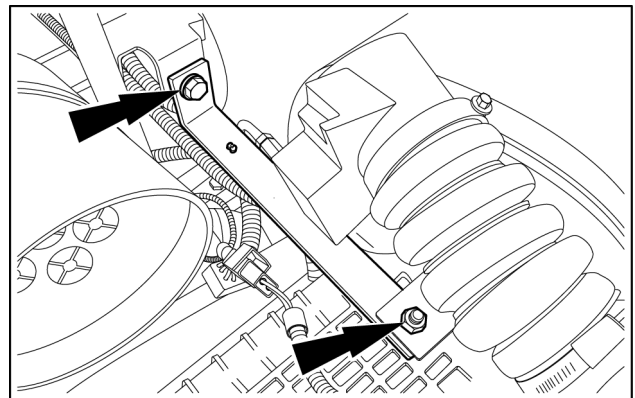

BAIL13TR01777AB 14

15. Install the air intake scoop.

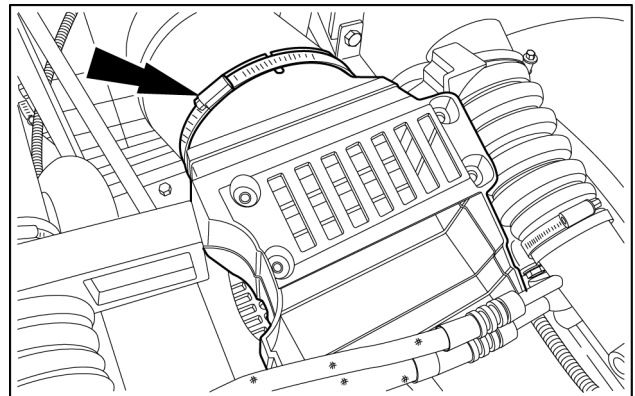

BAIL13TR01776AB 15

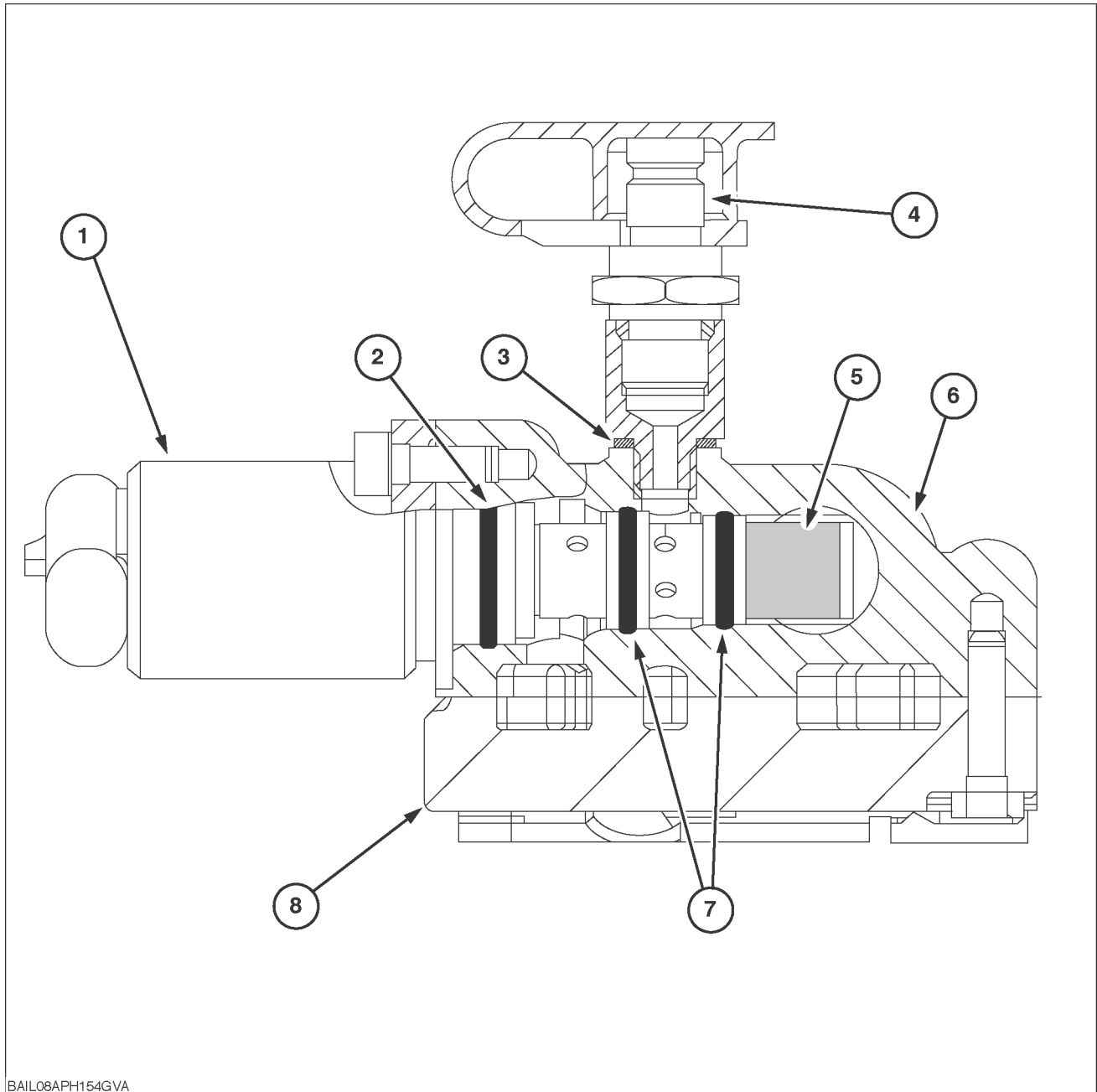

BAIL08APH154GVA

BAIL08APH154GVA 3

**Master Clutch Valve Section**

<b>(1)</b> Pulse width modulated (PWM) solenoid.	<b>(2)</b> O-ring seal.
<b>(3)</b> O-ring seal.	<b>(4)</b> Pressure test port.
<b>(5)</b> Gauze filter,	<b>(6)</b> Upper body.
<b>(7)</b> O-ring seals.	<b>(8)</b> Lower body.

22. Install the front cover plate.  
Tighten the retaining bolts to **23 Nm (17.0 lb ft)**.

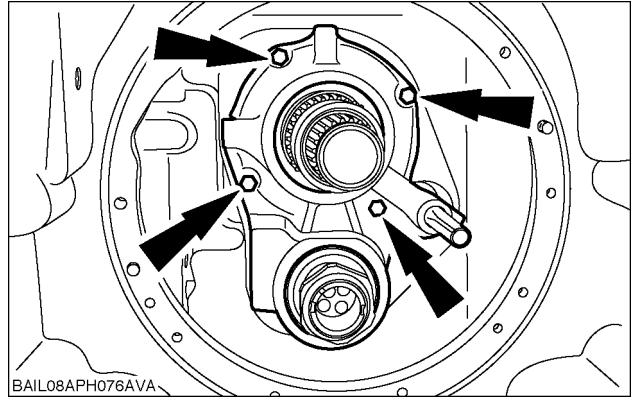

BAIL08APH076AVA

BAIL08APH076AVA 19

23. Install the oil delivery tubes.

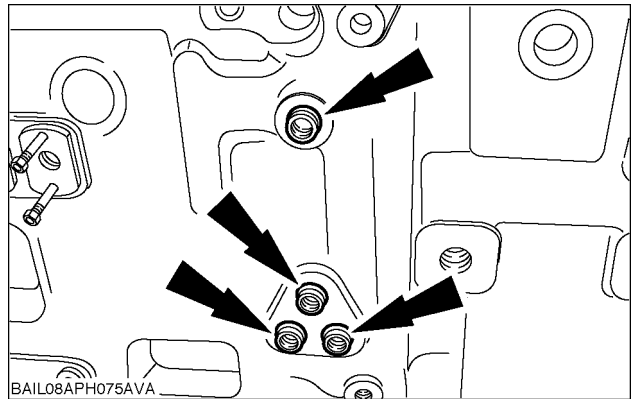

BAIL08APH075AVA

BAIL08APH075AVA 20

24. After installing the front cover and tightening retaining bolts, carry out the test in step **15** to check that there are no leaks from the manifold.
25. Tighten the retaining nut and stake over the edges of the nut.  
Tighten to **490 Nm (361.4 lb ft)**.

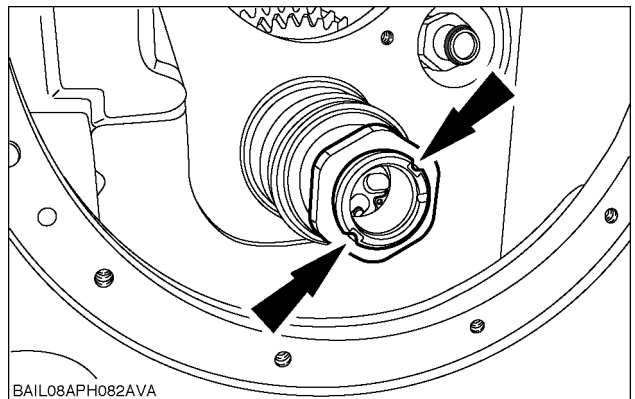

BAIL08APH082AVA

BAIL08APH082AVA 21

26. Install the gear and synchroniser, for further information, refer to **Gears - Install (21.152)**.
27. Install the clutch and gear master clutch, for further information refer to **Clutch Master clutch - Install (21.152)**.

8. Install the range clutch solenoids.

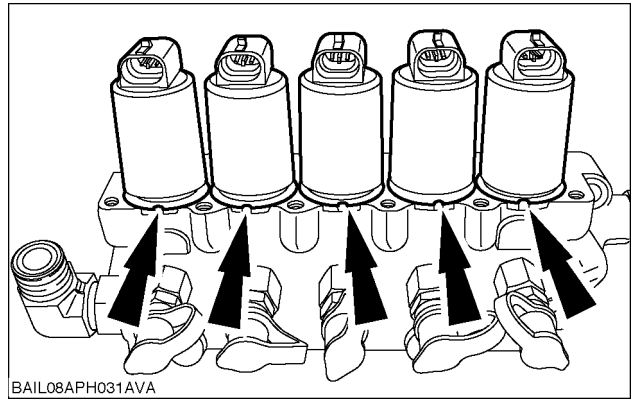

BAIL08APH031AVA 8

9. Install the range clutch solenoids retaining bracket.

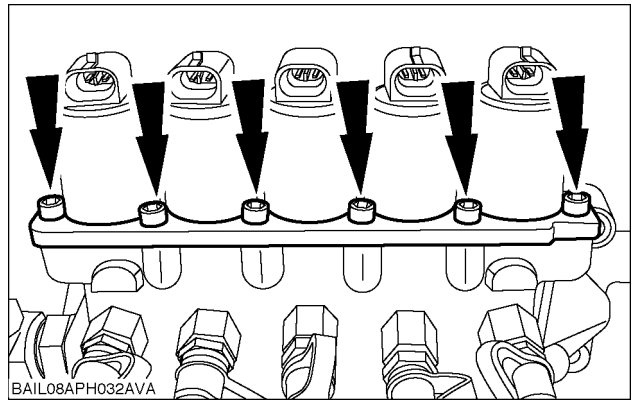

BAIL08APH032AVA 9

**Next operation:**

Install the master clutch valve, for further information refer to **Transmission control valve Master clutch valve - Install (21.133)**

**NOTE:** When changing from forward to reverse travel, the nearest available gear will be selected. As there are six ratios available in reverse, the ground speed in reverse gear may be different to the speed in the selected forward gear.

If you are travelling in a high gear, for example forward F15, and move the shuttle lever to the reverse position, the transmission will select the highest available ratio in reverse (R6).

If you then move the shuttle lever control to forward, gear F12 is engaged and the F12 segment is displayed on the display.

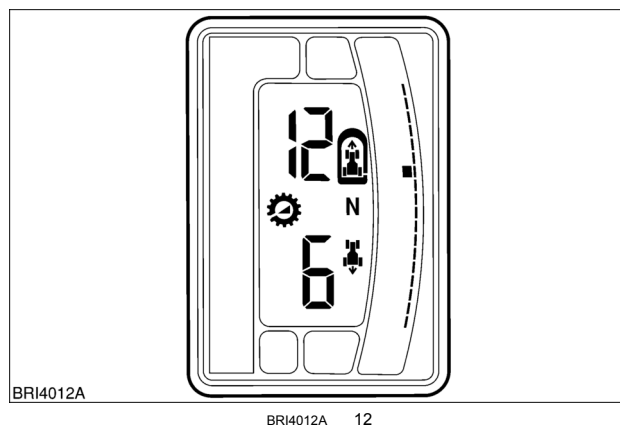

In the unlikely event of a fault in the electronic transmission control, the fault symbol (1) or the warning light lights up and a four-digit error code (2) is displayed in the dot matrix display in the instrument cluster. The transmission error codes begin with the number '2'.

The code indicates the tractor circuit or sensor in which the fault lies and the type of fault, e. g. an open circuit, short circuit, etc. See the list of error codes, .

There are several error codes that require an action from the driver, which are also displayed on the dot matrix display:

Error code	Require action
P	Parking brake or Park lock on, release to move the tractor.
CP	Depress clutch pedal to enable transmission to re-engage (restore drive).
N	Move the shuttle lever to Neutral.

#### CREEPER GEARS (where fitted)

For operations requiring extra low ground speeds, a reduction gear set (creeper gears) is available. This reduction gear set is installed in the main transmission housing and has a reduction ratio of 6:1.

With the reduction gears, an additional 10 forward and 6 reverse creeper gear ratios are provided. The creeper gears have the effect of reducing the ratios within the main transmission to provide very low operating speeds.

#### Engaging the creeper gears

**NOTICE:** Creeper gears make very low ground speeds possible. The greatly increased torque produced by the reduction should not be used to apply excessive draft loads to the tractor.

The creeper gears are selected using the following procedure:

Downshift to 1st gear and, with the engine running depress and hold the clutch and brake pedals. Depress and hold the downshift button until the transmission shifts to 10th gear in the creeper range. The symbol for the creeper speeds will appear in the transmission display.

Release the downshift button and the clutch and brake pedals. The appropriate creeper speed can now be selected using the upshift and downshift buttons.

To reengage the standard gear ratios, upshift to 10th creeper speed and depress/hold the clutch and brake pedals. Hold down the transmission upshift button until 1st gear is engaged, the creeper symbol will disappear from the display.

32. Rotate the transmission into the horizontal position. Insert a suitable tool through the speed sensor orifice to lock the Reverse shaft. Tighten Reverse shaft end nut to **467 - 515 Nm** using a **55 mm** socket. Lock tabs on the nut. Install Reverse clutch assembly end cap and fit circlip.

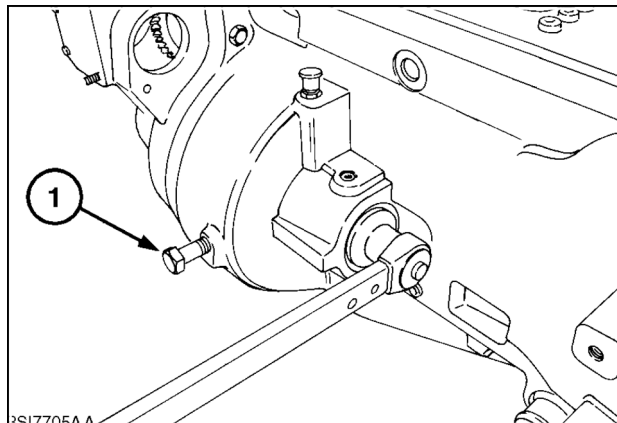

BSI7705AA

BSI7705AA 31

33. Install "A" clutch supply coupling and tube from A/B clutch housing.

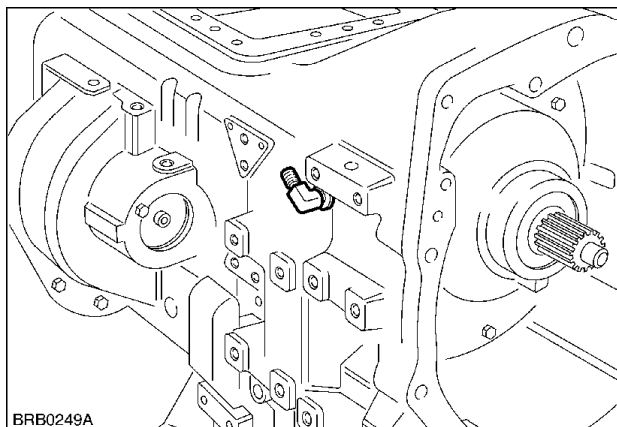

BRB0249A

BRB0249A 32

34. Install Reverse, Medium, Fast and Slow range pressure test couplers.  
35. Install 2 x speed sensors

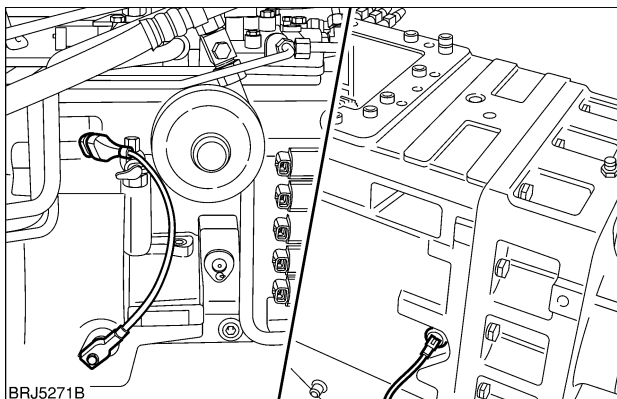

BRJ5271B

BRJ5271B 33

36. Install the "A" clutch supply pipe (1) and the PWM valve manifold (2).

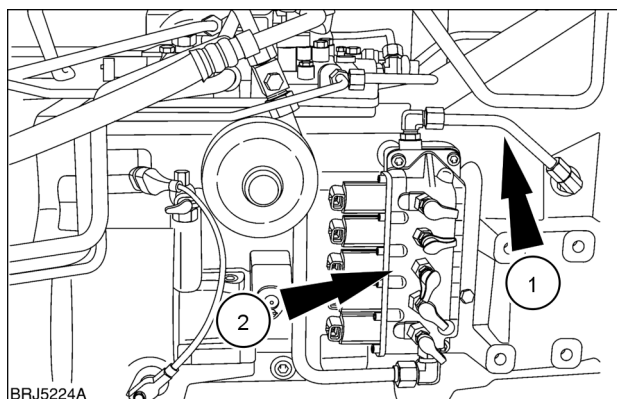

BRJ5224A

BRJ5224A 34

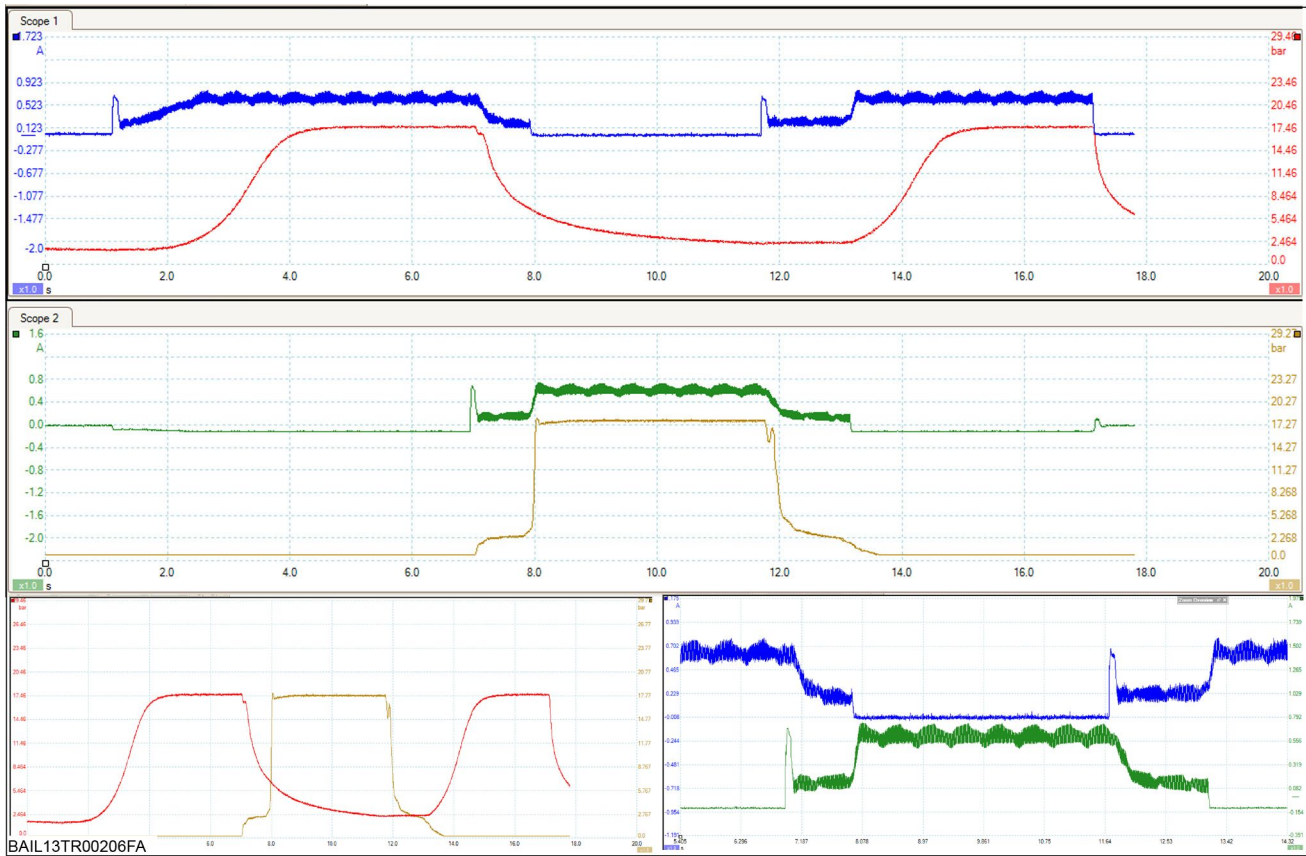

BAIL13TR00206FA 42

## Waveform notes

During this test the tractor set off in first gear using the master clutch, once the master clutch was fully engaged the vehicle was then shifted into second gear and finally shifted back to first gear again.

The blue line indicates the current going to clutch A, as clutch A is used for first gear it shows that the current going to the clutch jumps when the tractor starts to set off. The sharp spike shows the quick fill value going to the clutch, after the quick fill the solenoid gradually increases to maximum current. When second gear is selected the current going to clutch A falls away as clutch A is not used in second gear. When first gear is selected again it shows that current going to clutch A is restored. The red line indicates the pressure going to clutch A, it follows the current being applied to the A solenoid.

The green line shows the current going to clutch B, when second gear is selected the current jumps sharply supplying a quick fill to clutch B, at the same time the current going to clutch A falls away. When the quick fill has finished the current then ramps up to maximum to keep the clutch engaged. The brown line shows the pressure going to clutch B, it shows that it follows the current going to the solenoid.

**NOTE:** Note when the clutches are fully engaged the pressure shown is 17-19 bar.

4. Disconnect the synchroniser electrical connectors.

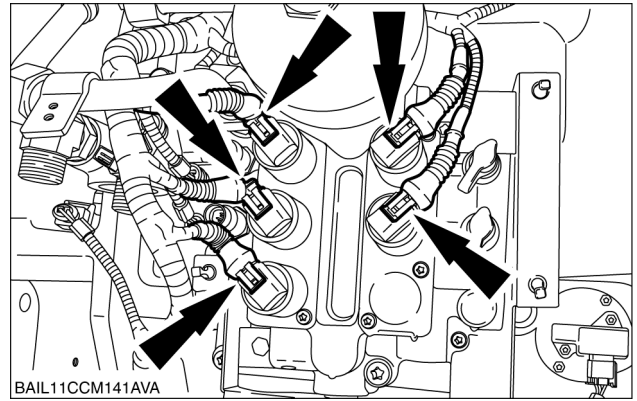

BAIL11CCM141AVA

BAIL11CCM141AVA 3

5. Disconnect the F2–R1 synchroniser and transmission oil temperature electrical connectors.

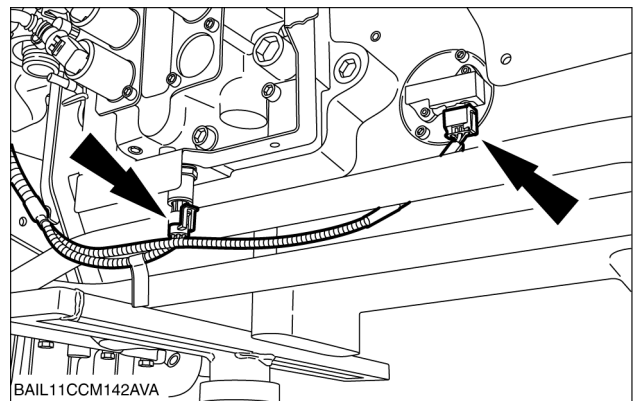

BAIL11CCM142AVA

BAIL11CCM142AVA 4

6. Disconnect the ring speed sensor electrical connector.

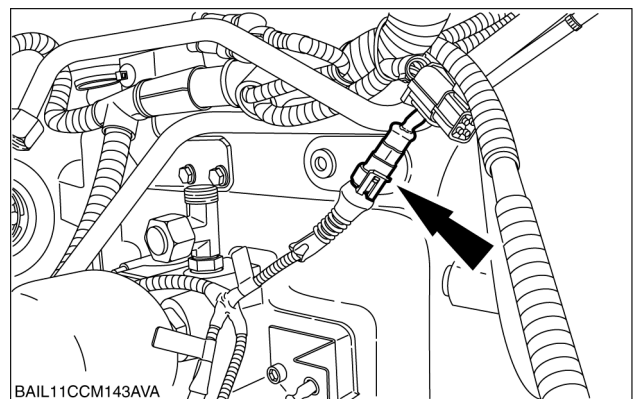

BAIL11CCM143AVA

BAIL11CCM143AVA 5

7. Disconnect the wiring harness electrical connectors.

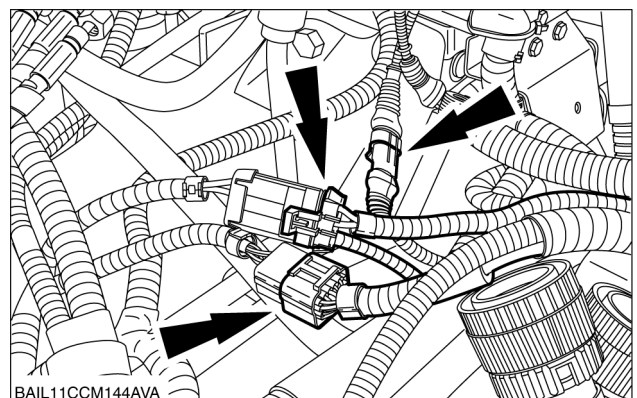

BAIL11CCM144AVA

BAIL11CCM144AVA 6

**Next operation:**

Disconnect the engine from the transmission, for further information refer to **Engine - Disconnect (10.001)**

4. Release the circlip (34) from its position. Remove the planetary gear carrier (32).

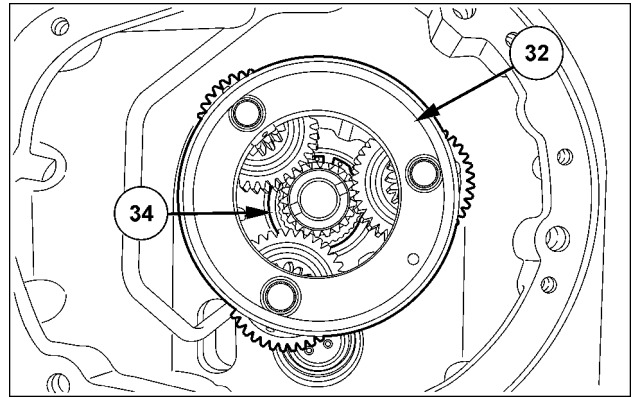

SS10F107 4

**NOTE:** Clean the components, check carefully for wear and damage, and replace if necessary.

**Next operation:**  
**Summing planetary gear - Disassemble (21.507)**

## Creeper mechanical internal control - Install

T7.175	ANZ --- APAC --- MEA
T7.190	ANZ --- APAC --- MEA
T7.210	ANZ --- APAC --- MEA

1. Install the selector shaft O-ring seal.

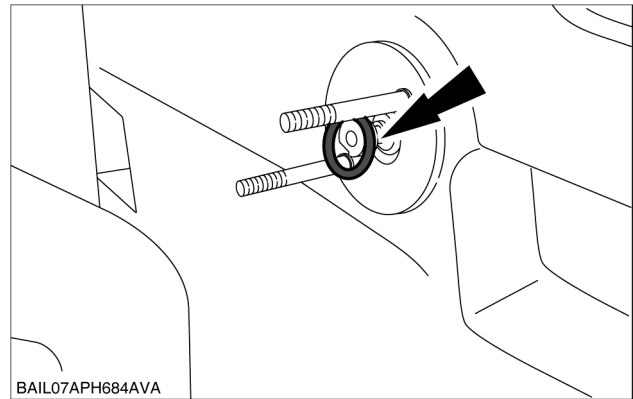

2. Install the potentiometer mounting plate.

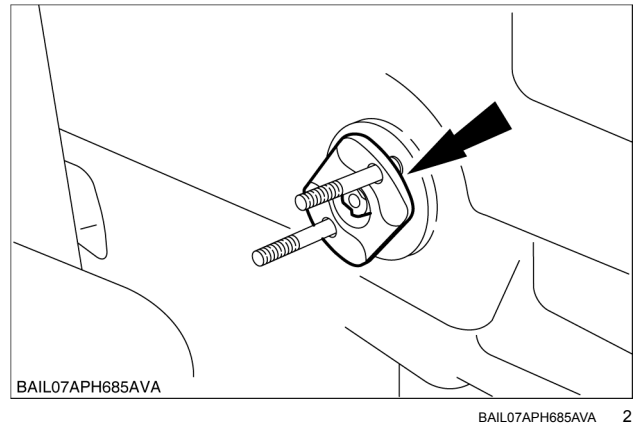

3. Install the oil seal (1)  
Install the selector shaft (2), selector fork (3) and the drive coupler (4).

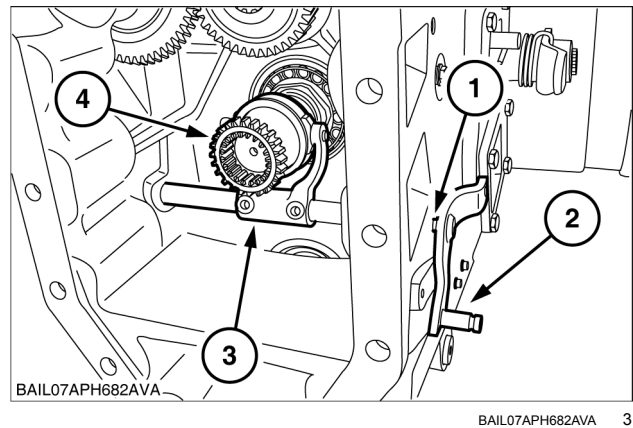

**PART A**

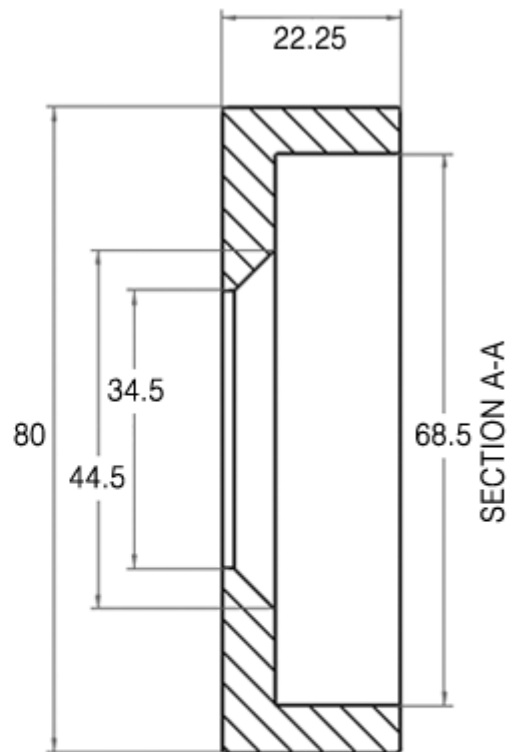
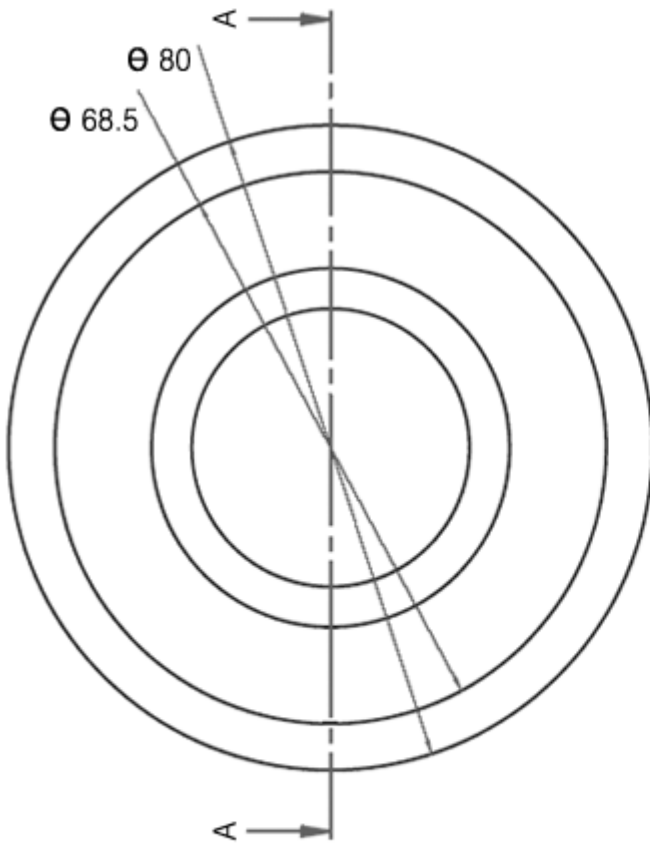
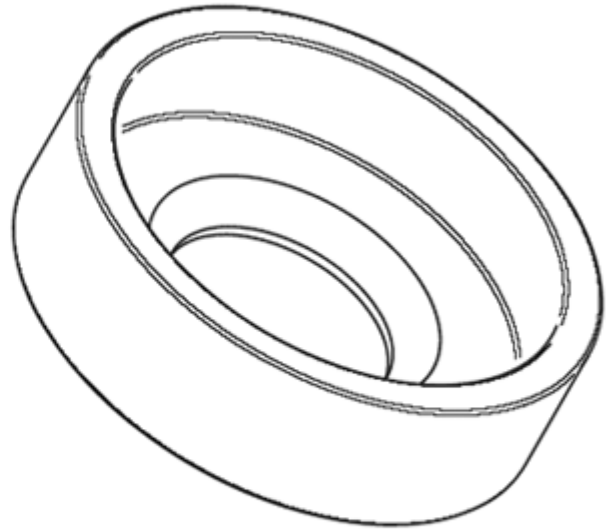

BAIL10CCM190ASA

BAIL10CCM190ASA 2

Front axle system - Powered front axle

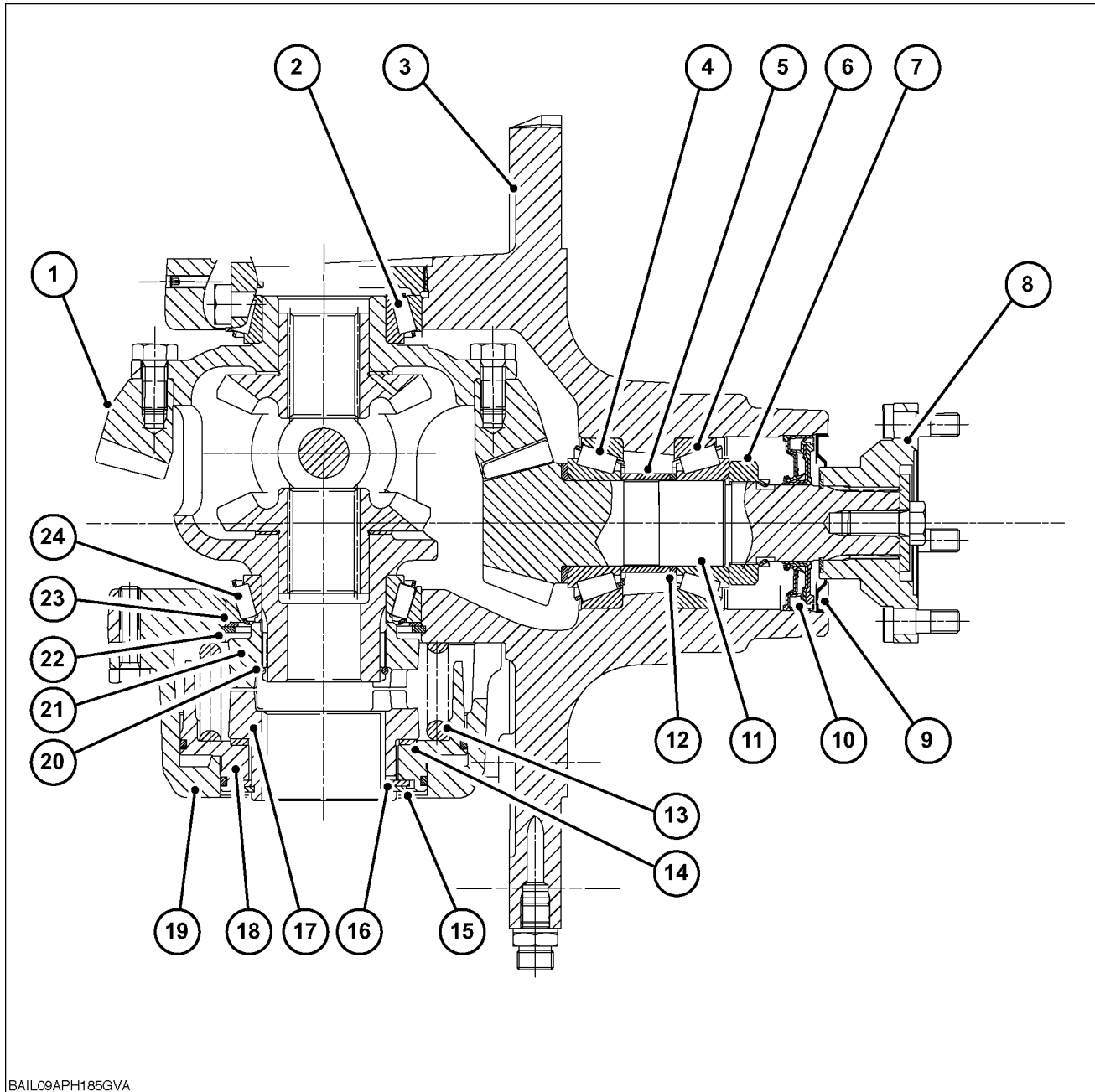

BAIL09APH185GVA

BAIL09APH185GVA 2

**Suspended Class 3+ Front Axle Cross Section with Dog Clutch**

1.	Crown wheel	13.	Spring
2.	Bearing	14.	Thrust washer
3.	Differential casing	15.	Circlip
4.	Bearing	16.	Thrust washer
5.	Spacer	17.	Dog clutch
6.	Bearing	18.	Piston
7.	Pinion nut	19.	Bell housing
8.	Pinion flange	20.	Locking ring
9.	Dust cover	21.	Dog clutch
10.	Pinion seal	22.	Circlip
11.	Pinion	23.	Shim
12.	Shim	24.	Bearing

## Bevel gear set and differential carrier - Exploded view

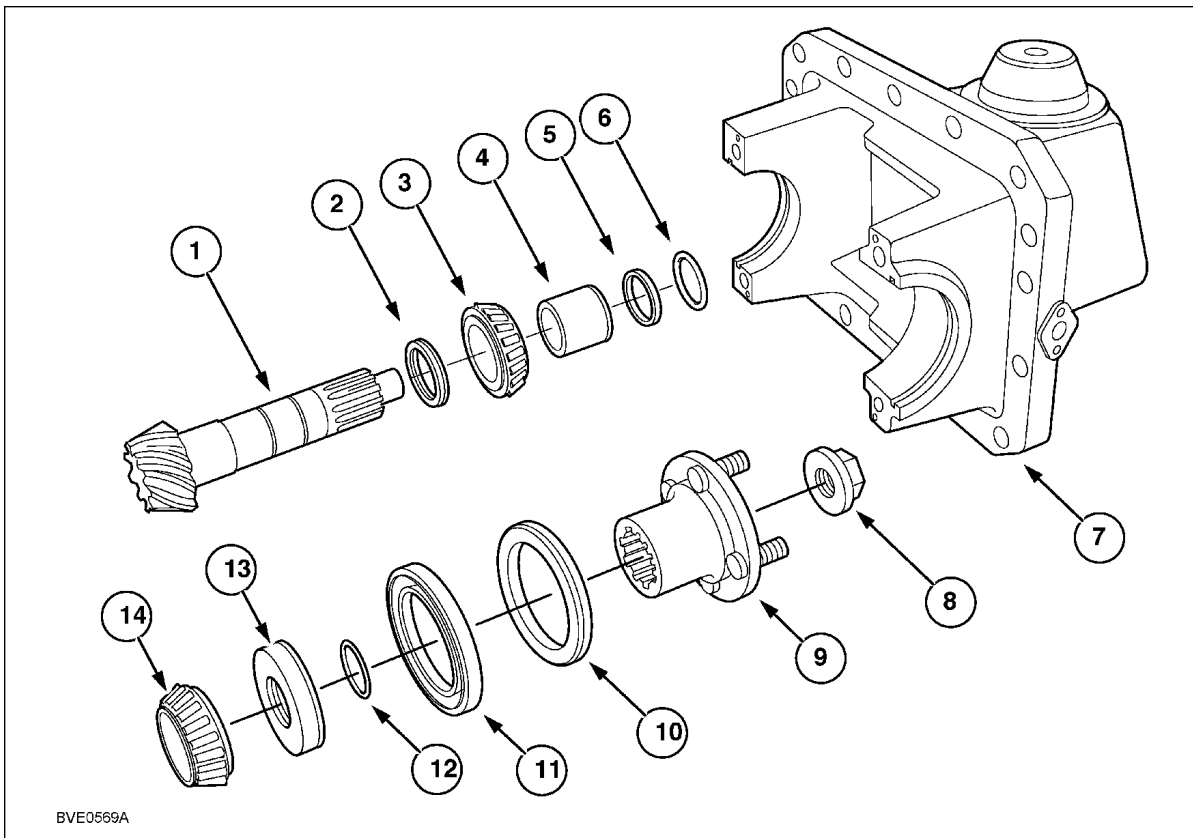

BVE0569A 1

### Suspended and SuperSteer Front Axle Pinion (Class 3+ Axle) Components (SuperSteer Front Axle Shown)

- |                        |                     |
|------------------------|---------------------|
| 1 Pinion               | 2 Pinion depth shim |
| 3 Bearing              | 4 Spacer            |
| 5 Shim                 | 6 O-ring seal       |
| 7 Differential casing  | 8 Pinion nut        |
| 9 Pinion flange        | 10 Dust cover       |
| 11 Pinion seal         | 12 O-ring seal      |
| 13 O-ring seal carrier | 14 Bearing          |

8. Using a suitable puller, remove the bearing (1).  
Remove the crown wheel (2).

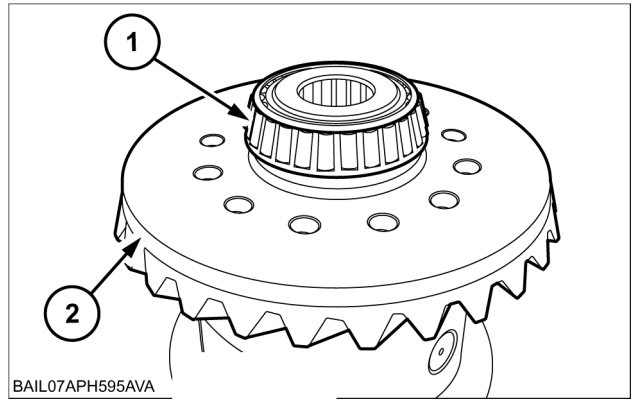

BAIL07APH595AVA 8

9. Remove the thrust washer.

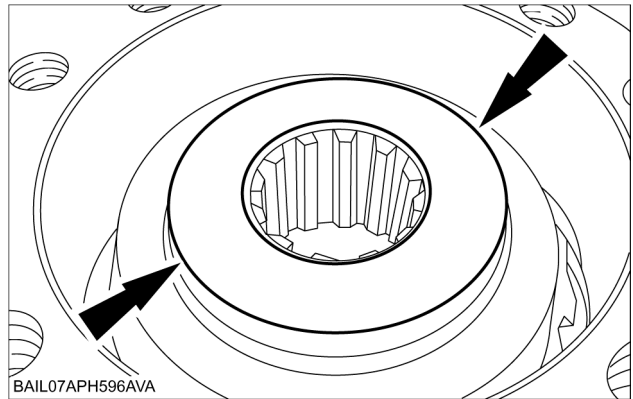

BAIL07APH596AVA 9

10. Remove the sun gear.

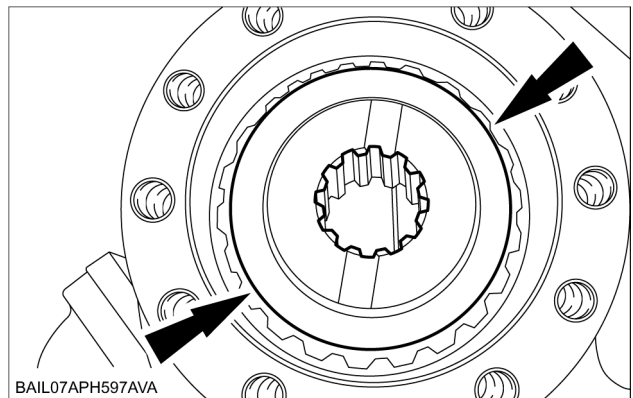

BAIL07APH597AVA 10

11. Remove the planet gear shaft locating pin.

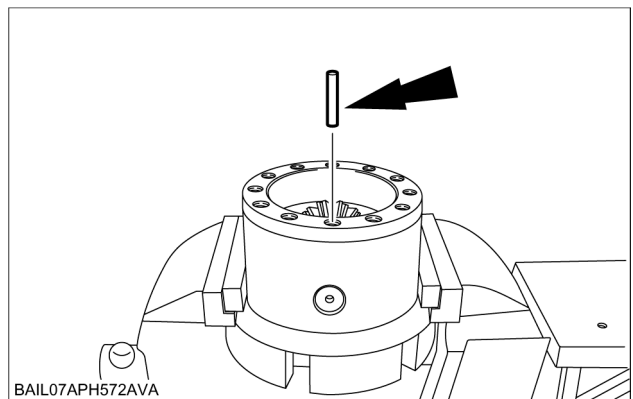

BAIL07APH572AVA 11

**NOTE:** When installing the right-hand side upper swivel pin assembly, take care to avoid damaging the steering sensor located within the housing.

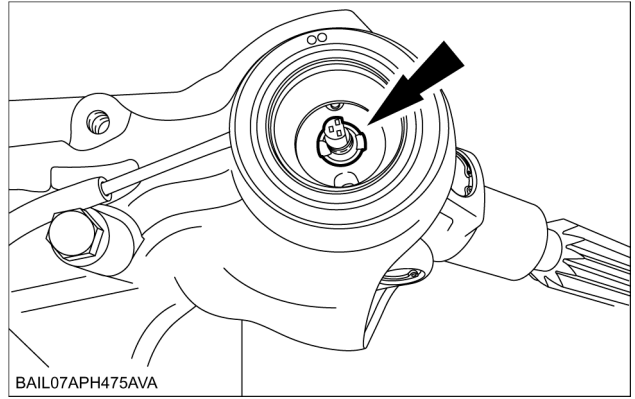

BAIL07APH475AVA

BAIL07APH475AVA 4

4. Install the lower swivel pin (1) and the shims (2) as removed.

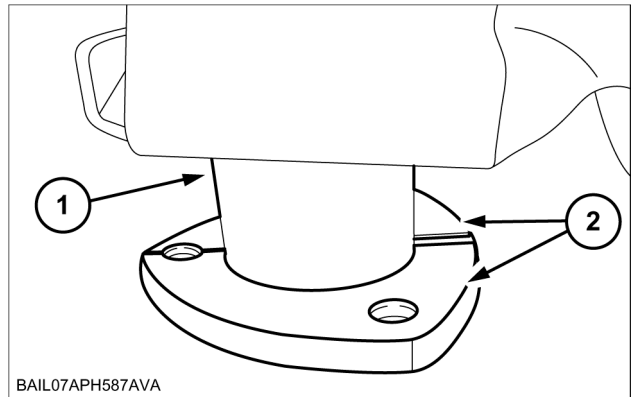

BAIL07APH587AVA

BAIL07APH587AVA 5

5. Install the lower swivel pin retaining bolts.

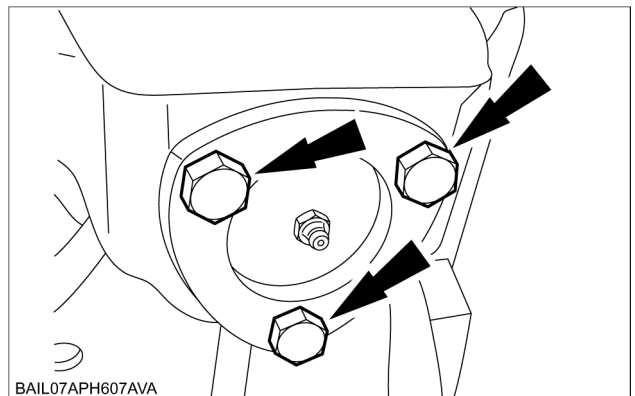

BAIL07APH607AVA

BAIL07APH607AVA 6

6. Connect the track rod end to the hub. Tighten to **113 Nm (83 lb ft)**.

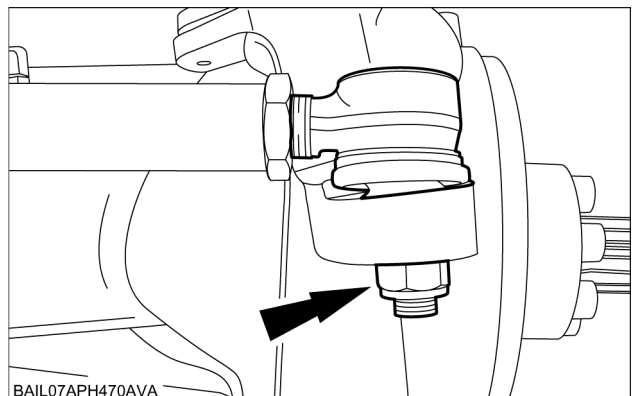

BAIL07APH470AVA

BAIL07APH470AVA 7

**380000549**  
 X **380000486**  
 X **380000403**  
 X **380200108**

Slide hammer.  
 Spacer and bushing (use with **380000470** ).  
 Lifting brackets  
 Dummy shaft (hydraulic pump idler gear bearing pre-load set-up)

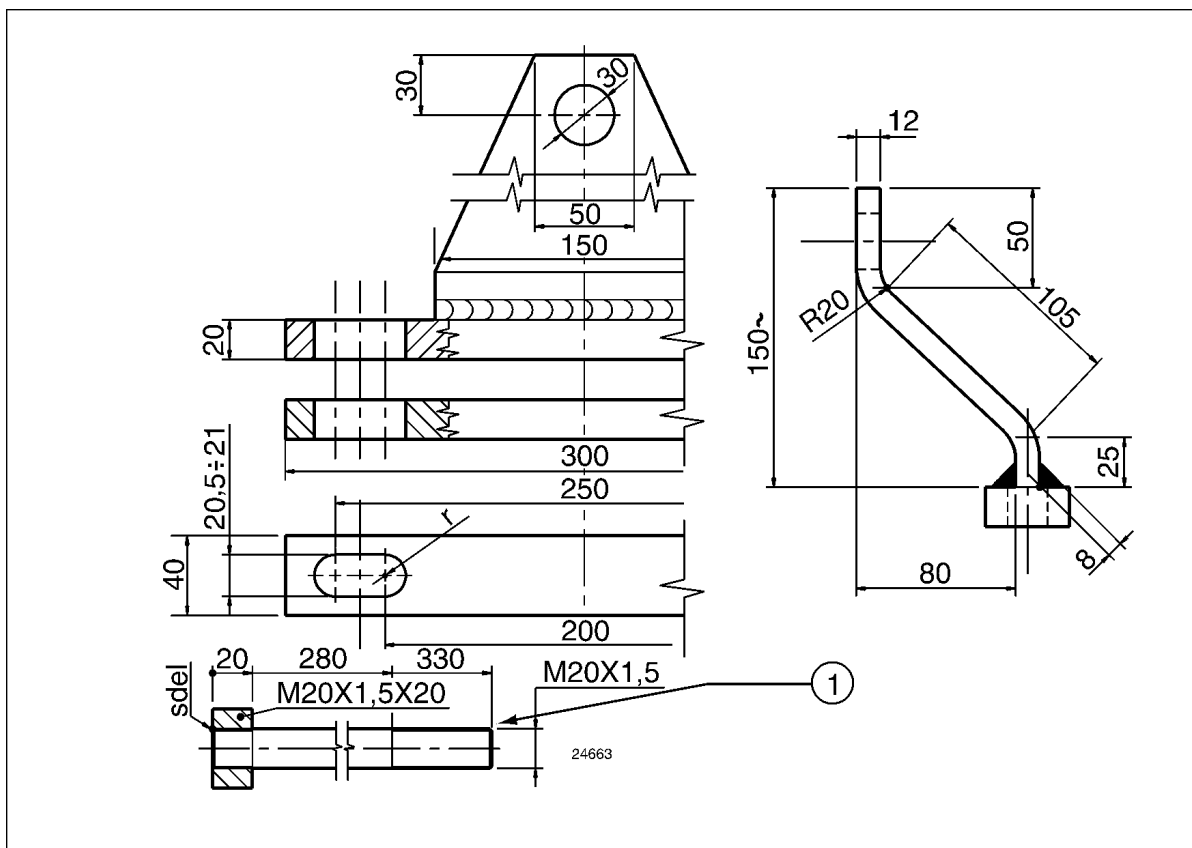

**Tool to be fabricated to disassemble-assemble the final drives (Mark tool with no. 50091 -  
 - Dimensions in mm).**

Fabricate tool using Aq 42 D. material

1. Make 2 legs in C 40 H&T material

Tool to be fabricated to disassemble-assemble the Bevel Pinion Shaft

- Make from **60 mm** socket (remove square drive end).
- Weld suitable rectangular piece of metal to socket (See Fig. 2).
- Use in conjunction with pinion drive coupler and **3/4 in** drive socket. (Refer to **Rear axle housing - Overhaul (27.100)**).

4. Remove the lifting bracket.

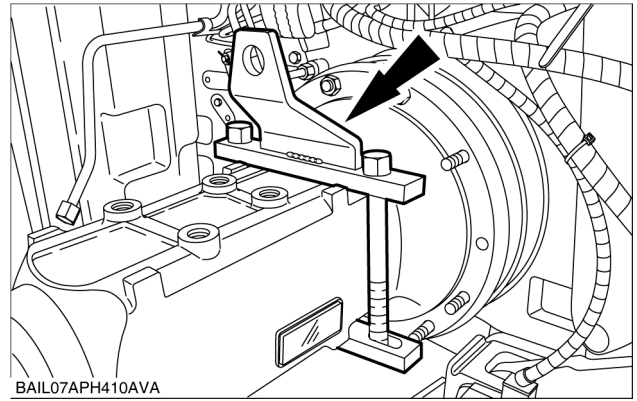

BAIL07APH410AVA 4

### Vehicles with Standard Cab

5. Install the cab support to the final drive housing.  
Tighten to **300 Nm (221 lb ft)**.

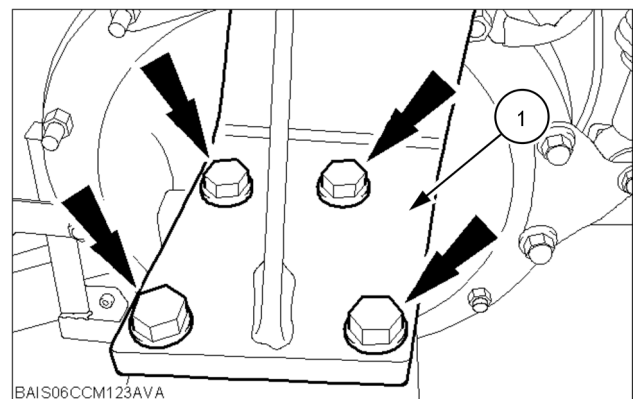

BAIS06CCM123AVA 5

6. Install the cab retaining nut.  
Tighten to **380 Nm (280 lb ft)**.

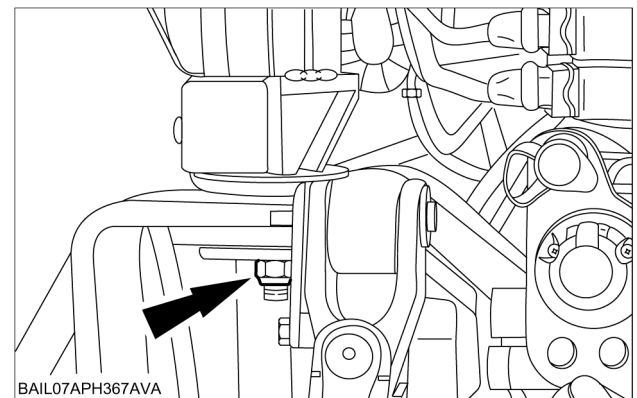

BAIL07APH367AVA 6

### Vehicles with Cab Suspension

7. Install the cab damper mounting bracket.

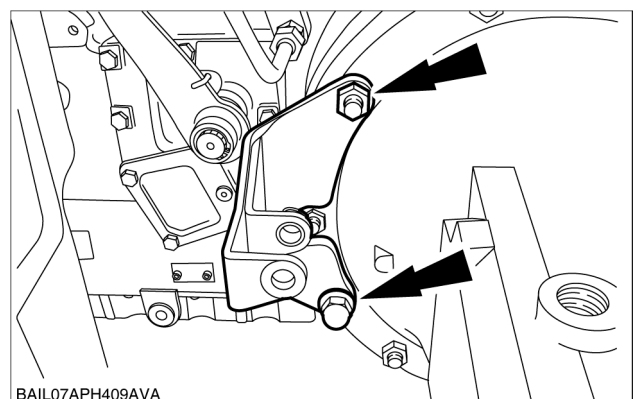

BAIL07APH409AVA 7

## PTO Speed Changes

Three speed shiftable PTO system allows in the seat changes of PTO speed. shaft speeds. Speed changes should be made with the PTO disengaged. The handle inside the cab incorporates a duplicate brake release button. This means the brake release can be operated at the same time as moving the handle to ease the shift.

With the tractor stationary and the PTO control knob in the disengaged position, select the required speed by means of the range lever. Depress the button (1) lift the spring loaded collar (2) and move the lever to engage the required PTO speed.

Depressing button (1) automatically releases the PTO brake providing a smoother engagement of the PTO ratio.

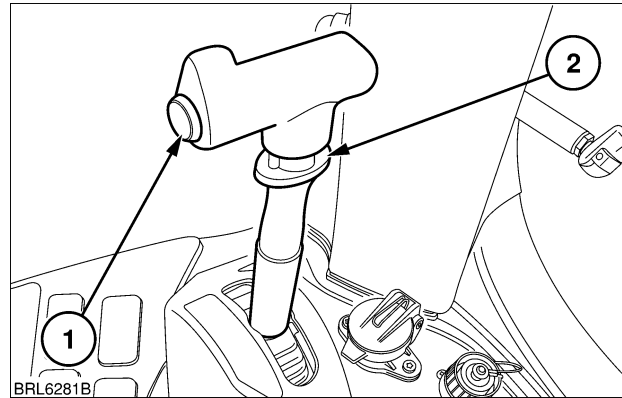

BRL6281B 5

**NOTICE:** Attempting to shift between speeds or from neutral to a speed position while the PTO is engaged will disable the system. Disconnect the PTO drive by moving the switch to neutral then re-select the required PTO speed.

### **⚠ WARNING**

**Machine damage can cause accidents!**

**Always use the recommended Power Take-Off (PTO) speed for the implement. Consult the implement operator's manual for the correct speed.**

**Failure to comply could result in death or serious injury.**

W0335A

8. Remove the split pin (1), remove the upper retaining pin (2) and remove the automatic pick-up hitch lift rod.

**NOTE:** Repeat this step for the right-hand side.

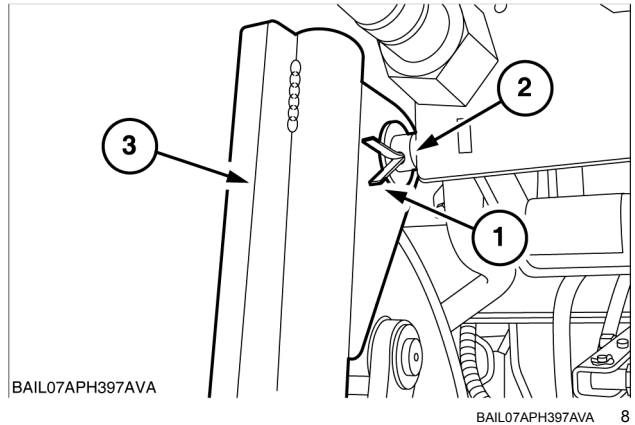

9. Disconnect the extending drawbar hydraulic supply and return pipes.

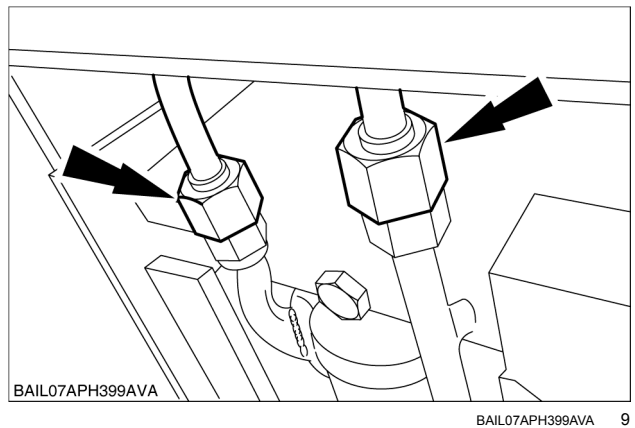

10. Support the extending drawbar and remove the retaining bolts.

**NOTE:** Repeat this step for the right-hand side.

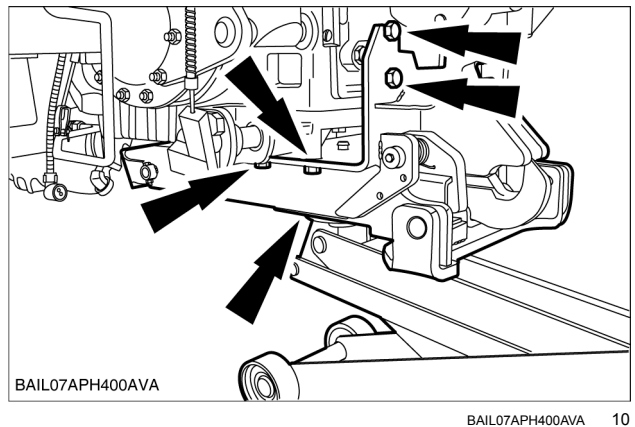

11. Remove the extending drawbar assembly.
12. Disconnect the power take off (PTO) speed sensor electrical connector.

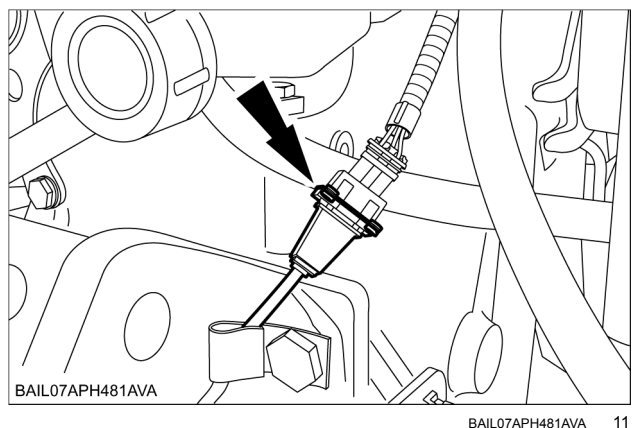

## Front PTO Reduction Gearbox Exploded View.

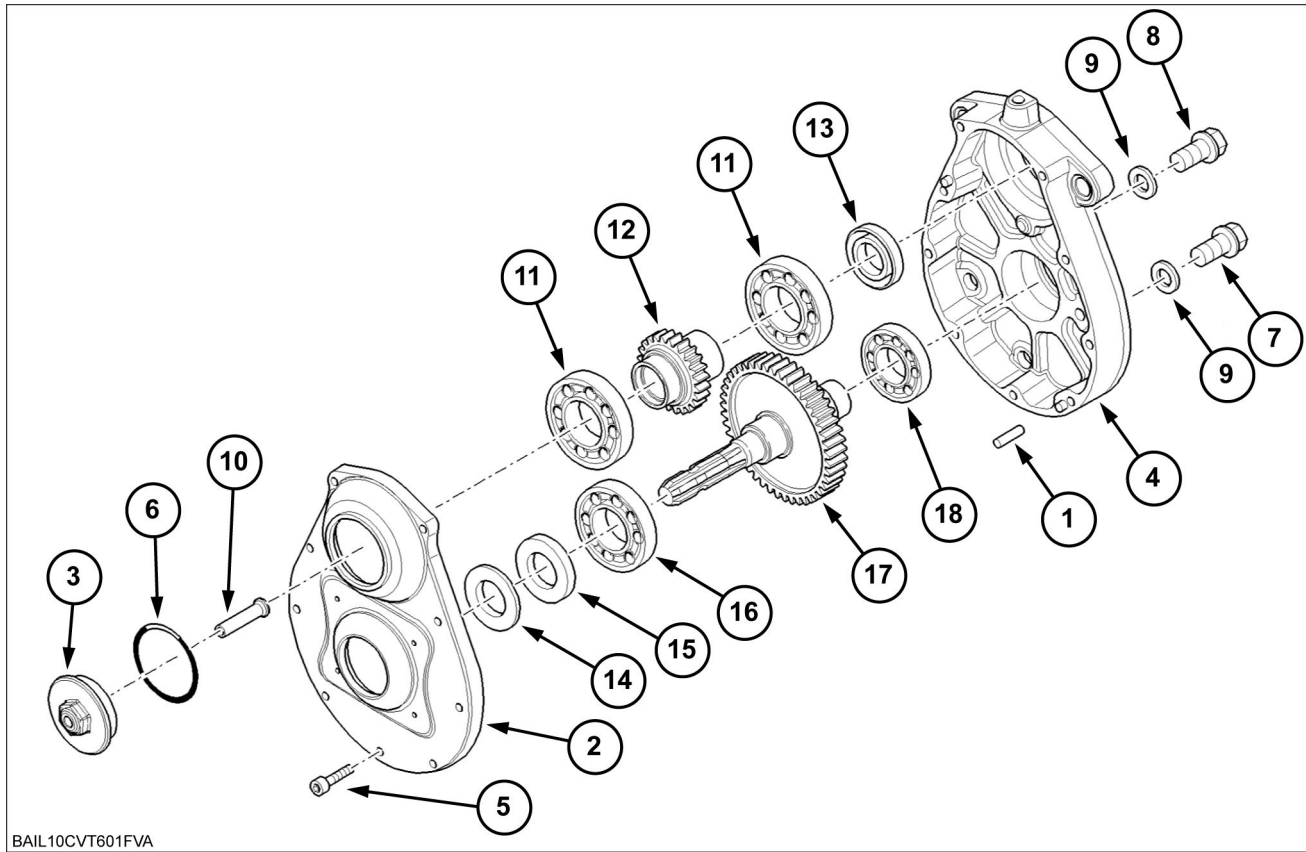

BAIL10CVT601FVA 3

- |                         |                    |
|-------------------------|--------------------|
| 1. Dowel                | 2. Housing cover   |
| 3. Input shaft cover    | 4. Housing         |
| 5. Cover retaining bolt | 6. O-Ring          |
| 7. Drain plug           | 8. Filler plug     |
| 9. Seal                 | 10. Tube           |
| 11. Bearing             | 12. PTO drive gear |
| 13. Seal                | 14. Retainer       |
| 15. Seal                | 16. Bearing        |
| 17. Output shaft        | 18. Bearing        |

### Next operation:

Assemble the gearbox, for further information refer to **Engine gearbox - Assemble (31.146)**.

3. Remove both master cylinder push rod clevis pin retaining clips (1), and remove the master cylinder push rod clevis pins (2).

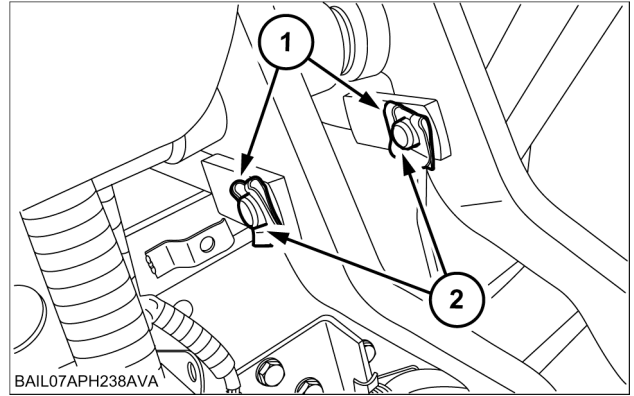

BAIL07APH238AVA 3

4. Remove the four master cylinder retaining bolts. Remove the master cylinder from the vehicle, from the engine side.

**NOTE:** Lubricate the gaiters to assist removal of the master cylinder.

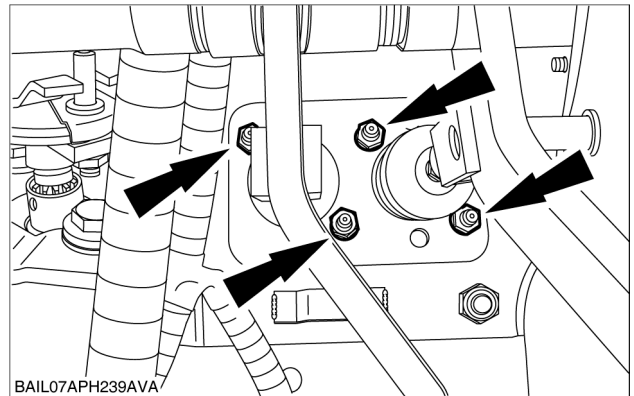

BAIL07APH239AVA 4

19. When full system pressure is achieved a pop should be heard as the relief valve operates. The red line pressure **(A)** must be **8.3 - 8.8 bar**.

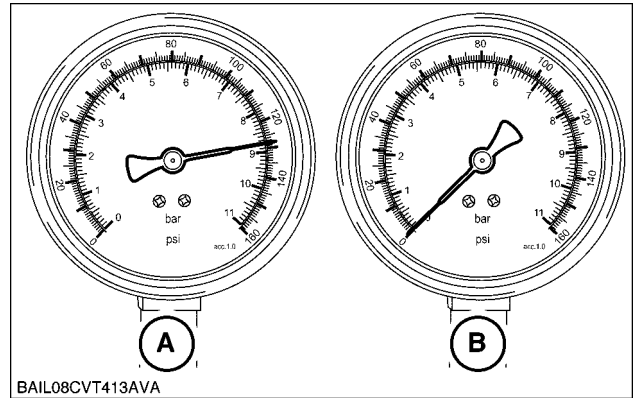

BAIL08CVT413AVA

BAIL08CVT413AVA 10

20. If the relief operation is incorrect, install a new dryer/relief valve assembly. **DO NOT** adjust the pressure setting of the valve.

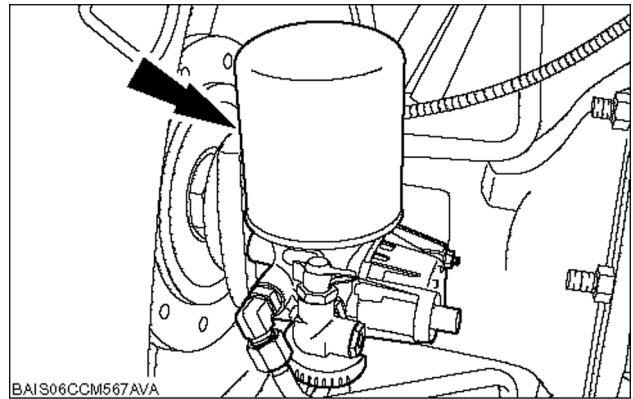

BAIS06CCM567AVA

BAIS06CCM567AVA 11

### Performance Check - Parking Brake Operation

21. With the engine at idle, apply the parking brake lever by 2-4 clicks on the ratchet. The test gauges must read as follows:  
 Red supply line **(A)** - **7.8 - 8.5 bar**.  
 Yellow control line **(B)** - **7.3 - 8.5 bar**.

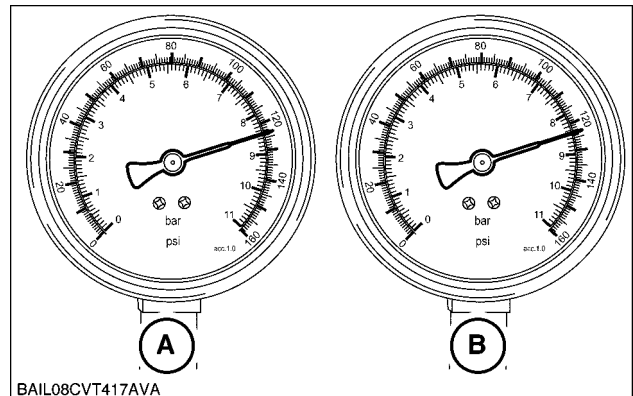

BAIL08CVT417AVA

BAIL08CVT417AVA 12

22. When the parking brake is released, the yellow control line pressure must drop to zero bar. If the pressure does not drop, check for the following possible faults:

## Hydrostat Filter Replace

- Using a suitable filter removal tool, remove the hydrostat oil filter.

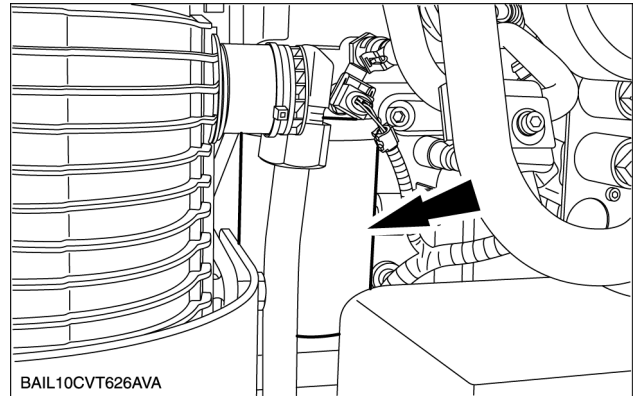

BAIL10CVT626AVA 2

- Before installing a new hydrostat filter, clean the inlet channel and the face of the filter mounting.
- Lubricate the new hydrostat filter rubber seal with clean hydraulic oil. Install the filter onto the filter mounting until both mating surfaces touch, then tighten a further 3/4 of a turn. Do not over tighten.

## Main Hydraulic Oil Filter Replace

- Remove the main hydraulic oil filter housing guard.

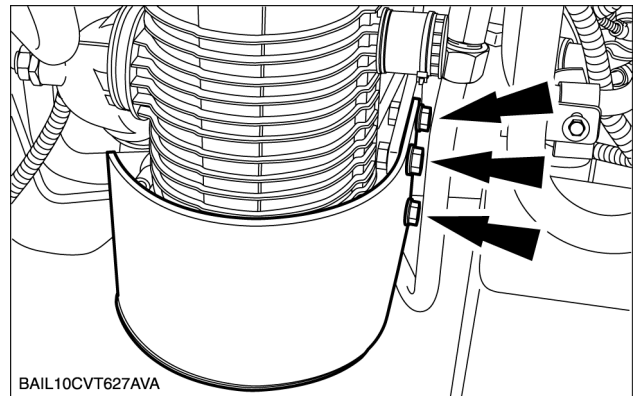

BAIL10CVT627AVA 3

- Release the air bleed valve (1) and wait a few moments for the oil to drain back to the reservoir. Remove the main hydraulic oil filter housing drain plug (2) and drain the oil into a suitable container.

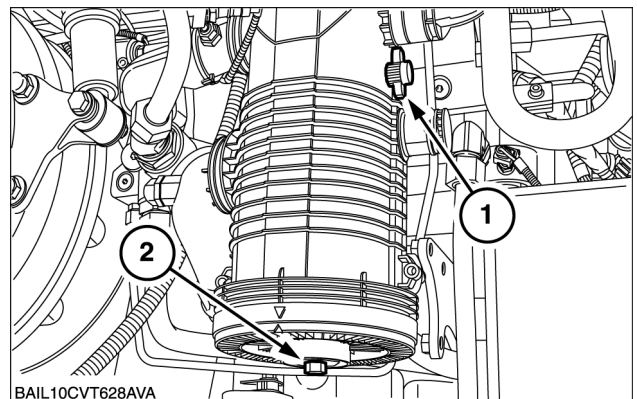

BAIL10CVT628AVA 4

## Low pressure valve Restrictor valve - Exploded view

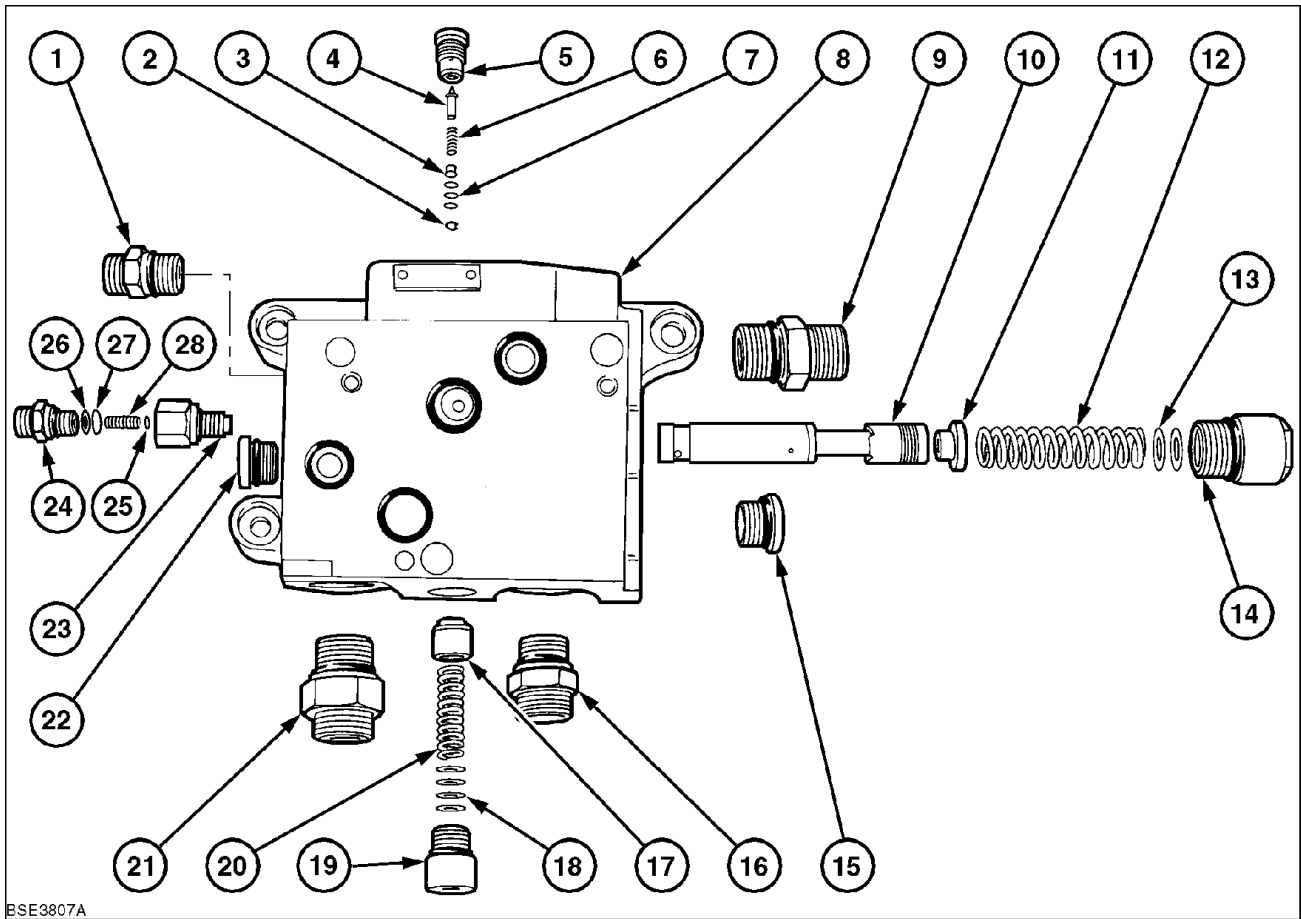

BSE3807A

BSE3807A 1

### Power Beyond and Pressure Regulating Valve Manifold

1	Low Pressure Feed Connector	2	Seal (Trailer brake load sensing shuttle valve)
3	Seat (Trailer brake load sensing shuttle valve)	4	Valve (Trailer brake load sensing shuttle valve)
5	Seat (Trailer brake load sensing shuttle valve)	6	Spring (Trailer brake load sensing shuttle valve)
7	Shims (Trailer brake load sensing shuttle valve)	8	Manifold Body
9	High Pressure Inlet Feed Connector	10	Pressure Regulating Valve Spool
11	Seat	12	Spring
13	Shims	14	End Cap
15	Plug	16	Power Beyond Connector
17	Poppet Valve	18	Shims
19	Plug	20	Spring
21	Power Beyond Connector	22	Plug
23	Seat (Load sensing line to priority valve)	24	Load Sensing Line Connector (Load sensing line to priority valve)
25	Seat (Load sensing line to priority valve)	26	Washer (Load sensing line to priority valve)
27	Washer (Load sensing line to priority valve)	28	Spring (Load sensing line to priority valve)

## Electro-hydraulic control valve - Remove

T7.175 AutoCommand™	ANZ --- APAC --- MEA
T7.175 Sidewinder II [ZFEN30001 - ]	ANZ --- APAC --- MEA
T7.190 AutoCommand™	ANZ --- APAC --- MEA
T7.190 Sidewinder II [ZFEN30001 - ]	ANZ --- APAC --- MEA
T7.210 AutoCommand™	ANZ --- APAC --- MEA
T7.210 Sidewinder II [ZFEN30001 - ]	ANZ --- APAC --- MEA

### 1. **⚠ WARNING**

#### Escaping fluid!

Hydraulic fluid or diesel fuel leaking under pressure can penetrate the skin and cause infection or other injury. To prevent personal injury: Relieve all pressure before disconnecting fluid lines or performing work on the hydraulic system. Before applying pressure, make sure all connections are tight and all components are in good condition. Never use your hand to check for suspected leaks under pressure. Use a piece of cardboard or wood for this purpose. If injured by leaking fluid, see your doctor immediately.

Failure to comply could result in death or serious injury.

W0178A

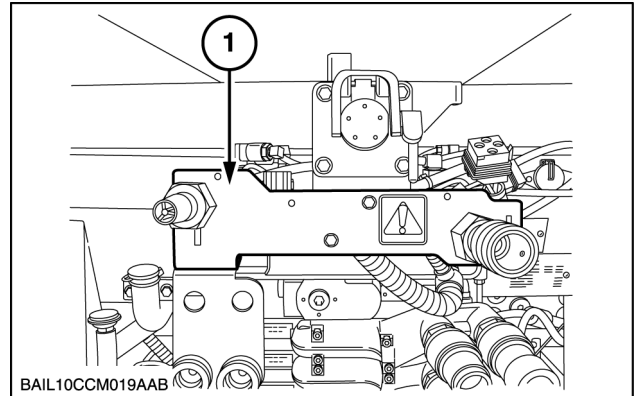

BAIL10CCM019AAB

BAIL10CCM019AAB 1

Remove the pneumatic brake bracket assembly (1) (where fitted).

2. Disconnect the remote valve harness connectors (1) from the solenoids.

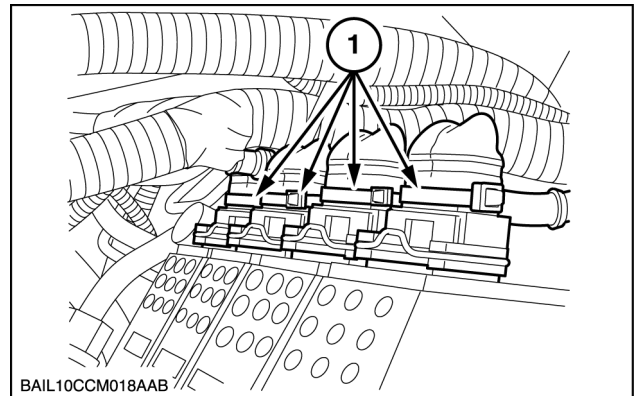

BAIL10CCM018AAB

BAIL10CCM018AAB 2

3. Disconnect the high pressure pilot line feed pipe (1).

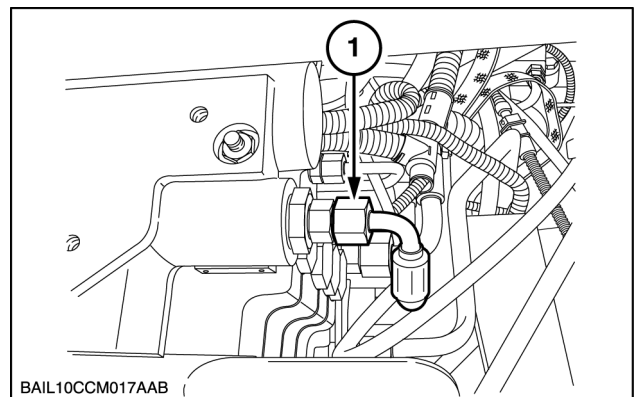

BAIL10CCM017AAB

BAIL10CCM017AAB 3

**NOTE:** Drain any excess fluid into a suitable receptacle

### **Vehicles with front suspension**

7. Calibrate the front suspension, for further information refer to **Electronic module Universal controller - H1 - Calibration procedures (55.640)**

7. Remove the tombstone cover plate securing bolts. Remove the cover plate.

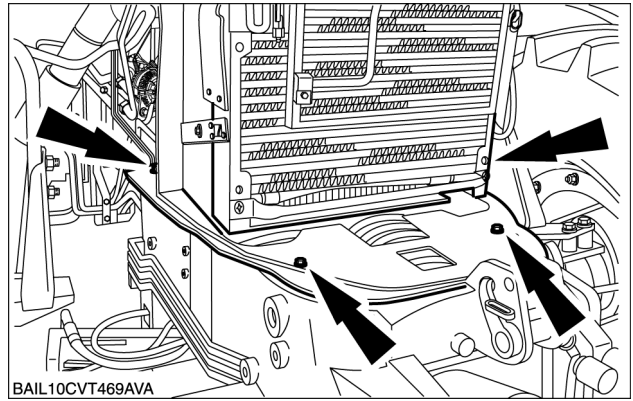

BAIL10CVT469AVA

BAIL10CVT469AVA 7

8. Support the hitch lower frame with a suitable jack (1). Remove the bolts securing the lift rams to the lower frame assembly (2).

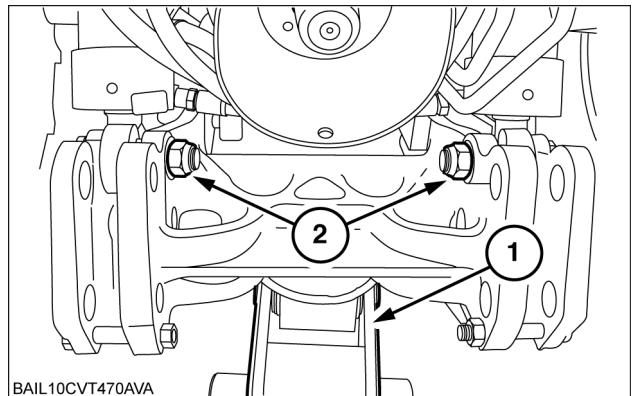

BAIL10CVT470AVA

BAIL10CVT470AVA 8

9. Remove the pins (1), and spacers (2) fitted each side of the lift cylinder eye.

**NOTE:** The inner spacers are thicker than the outer spacers.

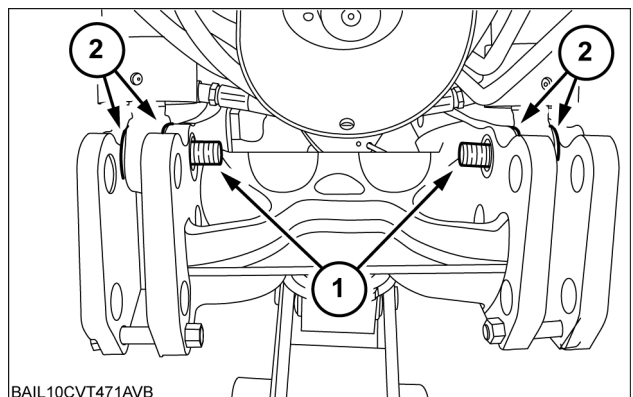

BAIL10CVT471AVB

BAIL10CVT471AVB 9

10. Lower the jack allowing the frame to swing back.

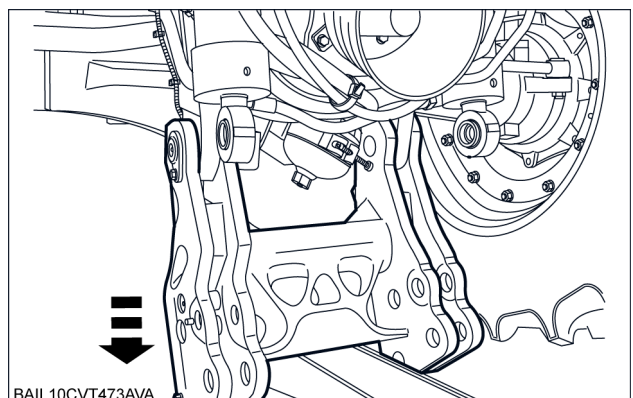

BAIL10CVT473AVA

BAIL10CVT473AVA 10

## Power steering wheel - Install Steering Wheel with Fast Steer

1. Install the steering wheel onto the steering column shaft.

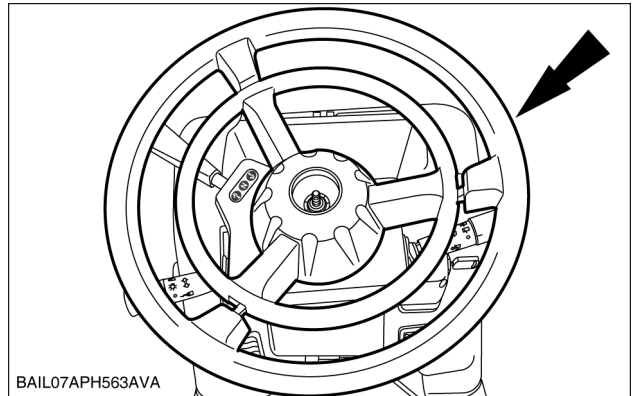

BAIL07APH563AVA 1

2. Install the steering wheel retaining nut. Tighten to **34 - 38 N·m (25 - 28 lb ft)**.

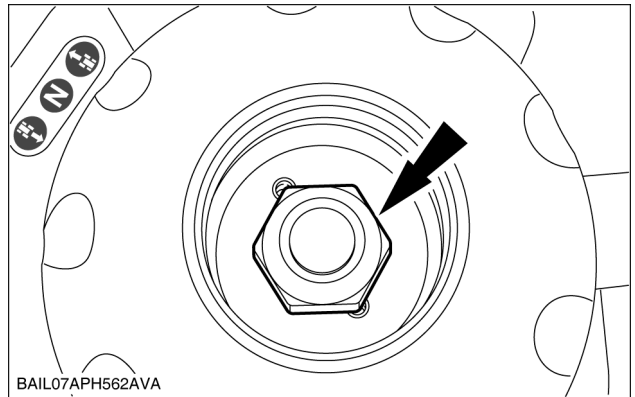

BAIL07APH562AVA 2

3. Install the rubber grommet.

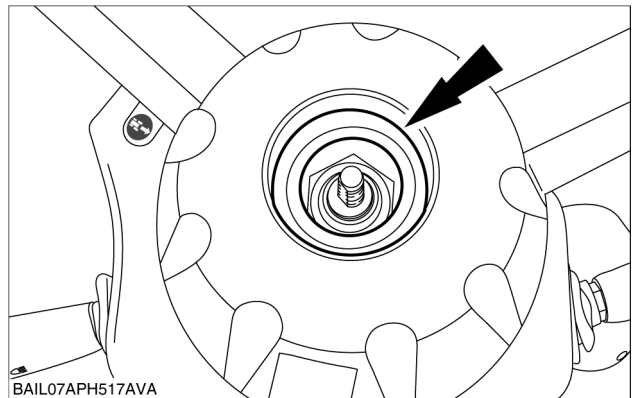

BAIL07APH517AVA 3

4. Install the steering wheel boss.

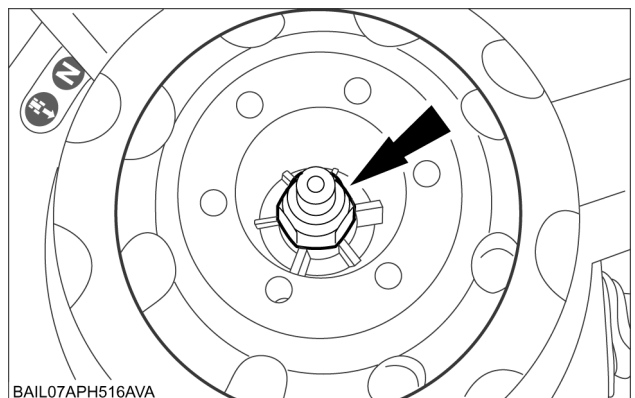

BAIL07APH516AVA 4

# Contents

---

## Wheels - 44

### Front wheels - 511

#### TECHNICAL DATA

Front wheels	
Torque .....	3

8. Ensure that the cab air filter is clean and not blocked.
9. Check whether the evaporator blades are stuck or heavily soiled.

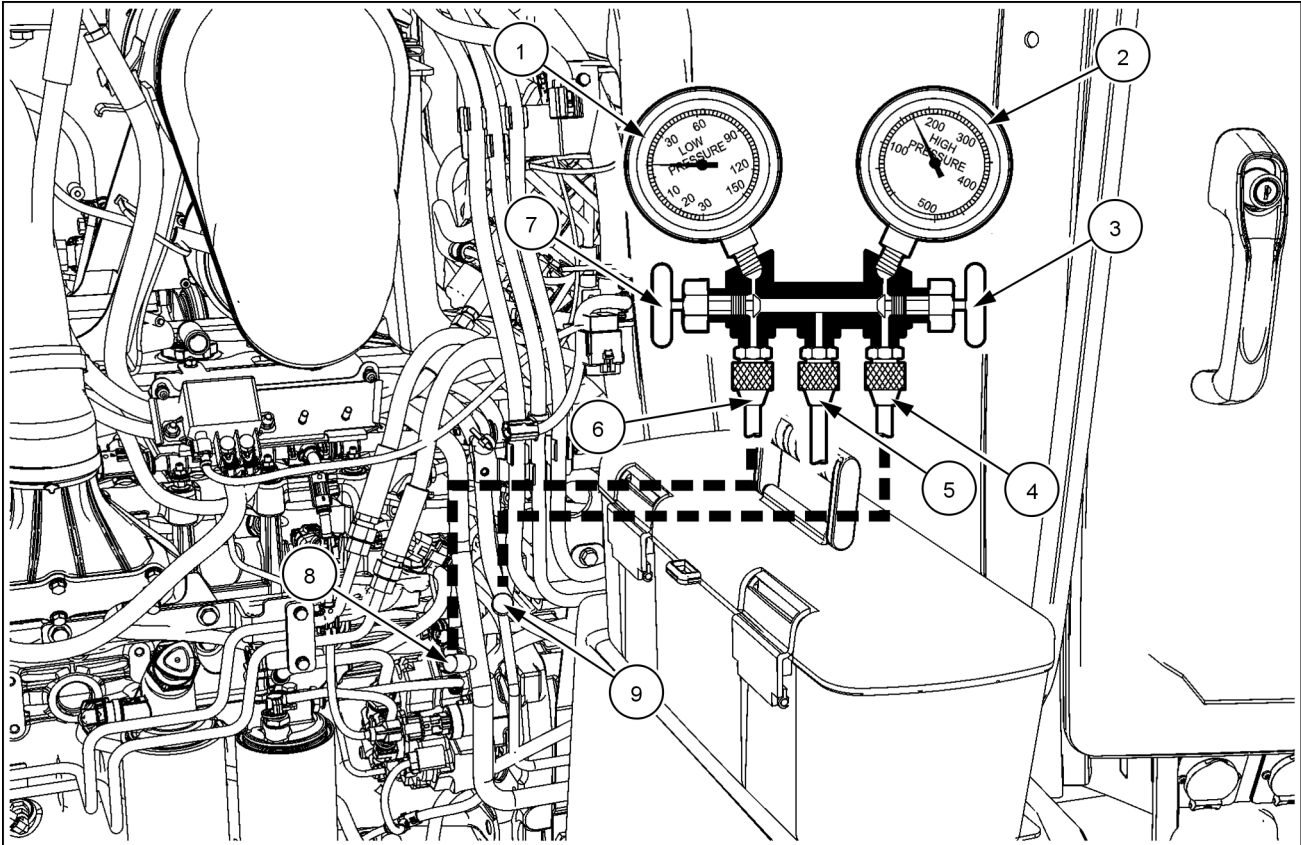

SS14D110 1

### Connection of pressure gauge battery to vehicle

- |  |  |
|--|--|
| 1. Suction side pressure gauge                         | 2. Pressure side pressure gauge                      |
| 3. Shut-off valve                                      | 4. Hose to pressure side connection valve            |
| 5. Centre hose (not in use)                            | 6. Hose to suction side connection valve             |
| 7. Shut-off valve                                      | 8. Suction side connection valve (low pressure part) |
| 9. Pressure side connection valve (high pressure part) |  |

### Checking the function of the air-conditioning system

10. The pressure gauge battery is the most important tool when checking and performing maintenance on the air-conditioning system.  
If the workshop has a modern automatic suction, evacuation, recycling and filling device the pressure gauges are already installed inside them.  
The following instructions for checking the function of the air-conditioning system apply to the pressure gauge battery shown in the diagram. The system check using a suction and filling device with pressure gauges fitted basically follows the same process.  
When using such devices, always note the operating instructions provided by the manufacturer.



## Wiring harnesses - Electrical schematic sheet 06 – POWER DISTRIBUTION (fuses 38 - 40)

T7.175 Standard [ZFEN30001 - ]	ANZ --- APAC --- MEA
T7.190 Standard [ZFEN30001 - ]	ANZ --- APAC --- MEA
T7.210 Standard [ZFEN30001 - ]	ANZ --- APAC --- MEA

### T7.175, T7.190, T7.210 – Standard

Component	Connector	Description
F-038	–	Rear Power Take-Off (PTO), Transmission display, <b>Lift-O-Matic™</b> , Top link switch, Lift rod switch, Switch panel right-hand side, Central Control Unit
F-039	–	Central Control Unit, Auxiliary Control Unit (ACU), Fast steering control module, ISO bus interface controller, Hitch switches, Remote valve switches, Autoguidance ON/OFF switch, Air-conditioning pressure switch – Switched battery power supply
F-040	–	Radio
S-007	<b>X-003</b>	Ignition switch
Z-002	<b>X-072</b>	Primary fuse block (K-014, K-044, K-045, MF1 to MF8, F-001 to F-070, F-092, V-001 to V-004, V-007, V-010)

Additional connectors: **X-110, X-127**

#### Wire color codes

BK Black	GN Green	PK Pink	BL Blue
TN Light Brown	BR Brown	OR Orange	LG Light Green
RD Red	GY Grey	LB Light Blue	
WH White	YE Yellow	VT Violet	

**T7.175, T7.190, T7.210 – Sidewinder II [Powershift transmission]**

Component	Connector	Description
A-080	<b>X-950, X-952, X-953, X-954, X-956</b>	Universal controller
E-043	<b>X-477</b>	Backup light
H-083	<b>X-476</b>	Backup alarm buzzer
K-060	<b>X-458</b>	Backup alarm buzzer and backup light – Relay
M-009	–	Seat compressor
R-017	–	Seat heater
S-032	<b>X-648</b>	Pressure switch (high range)
S-038	<b>X-646</b>	Pressure switch (low range)
S-040	<b>X-647</b>	Pressure switch (medium range)
S-096	–	Seat switch
Z-065	<b>X-081</b>	Seat assembly

Additional connectors: **X-020, X-022, X-026, X-455**

## Wire color codes

BK Black	GN Green	PK Pink	BL Blue
TN Light Brown	BR Brown	OR Orange	LG Light Green
RD Red	GY Grey	LB Light Blue	
WH White	YE Yellow	VT Violet	

## Wiring harnesses - Electrical schematic sheet 29 – HEATING, VENTILATION and AIR-CONDITIONING (Auto Temperature Control (ATC))

T7.175, T7.190, T7.210, T7.225 AutoCommand

T7.175, T7.190, T7.210 – Sidewinder II

Component	Connector	Description
A-006	–	Blower control unit
A-017	<b>X-755</b>	Automatic Temperature Control (ATC) module
B-050	–	Outside temperature sensor
B-051	–	Cab temperature sensor
B-053	–	Outlet temperature sensor
B-054	–	Evaporator temperature sensor
E-058	X-785	Air-conditioning – Control panel lighting
E-059	X-786	Air-conditioning – Control panel lighting
K-006	–	Blower motor relay
K-019	<b>X-074</b>	Air-conditioning compressor relay
M-011	–	Blower motor
R-003	–	Resistor
R-004	–	Resistor
R-006	–	Resistor
R-030	<b>X-751</b>	Temperature control potentiometer
S-015	<b>X-750</b>	Blower switch
S-016	<b>X-752</b>	Air-conditioning system – Mode switch
S-017	<b>X-225</b>	Air-conditioning system-pressure switch
S-061	–	Low pressure switch
Y-052	<b>X-774</b>	Heating control valve
Y-082	<b>X-226</b>	Air-conditioning compressor – Magnetic clutch
Z-001	<b>X-754</b>	Blower assembly
Z-069	<b>X-753</b>	Air-conditioning assembly
Z-093	<b>X-035</b>	Relay and fuse block (K-006 to K-057)
–	<b>X-086D</b>	Ground connection

Additional connectors: **X-024, X-695, X-752A, X-760**

Wire color codes

BK Black	GN Green	PK Pink	BL Blue
TN Light Brown	BR Brown	OR Orange	LG Light Green
RD Red	GY Grey	LB Light Blue	
WH White	YE Yellow	VT Violet	

**Wiring harnesses - Electrical schematic sheet 46 – ELECTRONIC  
PARKING BRAKE**

T7.175, T7.190, T7.210, T7.225 AutoCommand

Component	Connector	Description
A-012	X-745	Electronic Park Lock (EPL) controller
K-011	X-036	Hydraulic trailer brake – Parking brake relay
S-030	X-121	Hand brake position switch

Additional connectors: –

Wire color codes

BK Black	GN Green	PK Pink	BL Blue
TN Light Brown	BR Brown	OR Orange	LG Light Green
RD Red	GY Grey	LB Light Blue	
WH White	YE Yellow	VT Violet	

Electrical systems - Harnesses and connectors

CIRCUIT	COLOR	DESCRIPTION
5135	LB (TQ)	EDC +WHEEL SPEED SIGNAL
5140	LB (TQ)	EDC -WHEEL SPEED SIGNAL
5145	LB (TQ)	EDC SLIP LIMIT POT
5150	GN (G)	EDC EXTERNAL SWITCH SUPPLY
5155	BL (U)	EDC LOWER LIMIT POT
5160	LB (TQ)	EDC HEIGHT LIMIT POT FEED
5170	TN (LN)	SERIAL DATA FROM CLUSTER
5175	RD (R)	ADIC KEY PAD DISABLE
5180	LB (TQ)	EDC SLIP INDICATOR LAMP
5190	RD (R)	HPL INTERLOCK / LIFT-O-MATIC
5200	BR (N)	EDC VALVE SUPPLY
5205	BR (N)	INTERNAL FENDER HITCH SWITCH - UP
5210	BR (N)	EDC VALVE ENABLE
5215	BR (N)	INTERNAL FENDER HITCH SWITCH - DOWN
5220	YE (Y)	EDC RAISE LAMP
5230	YE (Y)	EDC LOWER LAMP
5240	OR (O)	EDC RAISE SIGNAL-RAISE WORK SWITCH No.2
5250	OR (O)	EDC WORK SIGNAL-RAISE WORK SWITCH No.2
5260	TN (LN)	HYDRAULIC MASTER SW #1
5265	TN (LN)	HYDRAULIC MASTER SW #2
5270	BR (N)	JOYSTICK LED – FRONT
5300	PK (K)	ECU FLASH PROGRAM SIGNAL
5400	YE (Y)	CAN H
5420	GN (G)	CAN L
5500	RD (R)	EHR CAN HIGH
5510	BL (U)	EHR CAN LOW
5515	GY (S)	EHR +12V IGN.
5520	LG	EHR 5V REF.
5521	LG	EHR MOTOR #1
5522	LG	EHR MOTOR #2
5523	LG	EHR MOTOR #3
5524	LG	EHR MOTOR #4
5531	LG	EHR NEUTRAL SWITCH VALVE #1
5532	GN (G)	EHR NEUTRAL SWITCH VALVE #2
5533	PK (K)	EHR NEUTRAL SWITCH VALVE #3
5534	LG	EHR NEUTRAL SWITCH VALVE #4
5535	LG	EHR FLOAT SWITCH VALVE#1
5536	TN (LN)	EHR FLOAT SWITCH VALVE#2
5537	BR (N)	EHR FLOAT SWITCH VALVE#3
5538	OR (O)	EHR FLOAT SWITCH VALVE#4
5541	OR (O)	EHR MAX.FLOW SWITCH VALVE #1
5542	VT (P)	EHR MAX.FLOW SWITCH VALVE #2
5543	GY (S)	EHR MAX.FLOW SWITCH VALVE #3
5544	LB (TQ)	EHR MAX.FLOW SWITCH VALVE #4
5551	OR (O)	EHR POTENTIOMETER SIGNAL VALVE#1
5552	BL (U)	EHR POTENTIOMETER SIGNAL VALVE#2
5553	WH (W)	EHR POTENTIOMETER SIGNAL VALVE#3
5554	BL (U)	EHR POTENTIOMETER SIGNAL VALVE#4
5561	OR (O)	EHR TIMED FLOW SWITCH #1
5562	OR (O)	EHR TIMED FLOW SWITCH #2
5563	OR (O)	EHR TIMED FLOW SWITCH #3
5564	VT (P)	EHR TIMED FLOW SWITCH #4
5570	VT (P)	FENDER 3RD EHR SWITCH (RES)
5571	VT (P)	FENDER 3RD EHR SWITCH (RES)
5572	VT (P)	FENDER 3RD EHR SWITCH (RES)

<b>CONNECTOR X-022 - On harness 47357335</b>				
<b>PIN NUMBER</b>	<b>WIRE NUMBER</b>	<b>CIRCUIT REFERENCE</b>	<b>ELECTRICAL SCHEMATIC FRAME</b>	
1	TR-3024 (YE)	From X-022 to <b>X-279</b>	<b>Wiring harnesses - Electrical schematic sheet 14 (55.100)</b>	
2	-	-		
3	TR-7080 (LG)	From X-022 to <b>X-276</b>		
4	TR-2130 (BR)	From X-022 to <b>X-277</b>		
5	TR-2051 (OR)	From X-022 to <b>X-278</b>		
6	TR-2042 (OR)	From X-022 to <b>X-278</b>		<b>Wiring harnesses - Electrical schematic sheet 15 (55.100)</b>
7	TR-2140A (OR)	From X-022 to <b>X-251</b>		<b>Wiring harnesses - Electrical schematic sheet 16 (55.100)</b>
8	TR-2062A (WH)	From X-022 to <b>X-262</b>		<b>Wiring harnesses - Electrical schematic sheet 17 (55.100)</b>
9	TR-7910 (LB)	From X-022 to <b>X-528</b>		<b>Wiring harnesses - Electrical schematic sheet 18 (55.100)</b>
10	-	-		<b>Wiring harnesses - Electrical schematic sheet 19 (55.100)</b>
11	-	-		<b>Wiring harnesses - Electrical schematic sheet 20 (55.100)</b>
12	-	-		<b>Wiring harnesses - Electrical schematic sheet 21 (55.100)</b>
13	-	-		<b>Wiring harnesses - Electrical schematic sheet 22 (55.100)</b>
14	-	-		<b>Wiring harnesses - Electrical schematic sheet 23 (55.100)</b>
15	TR-7940 (LB)	From X-022 to <b>X-543</b>		<b>Wiring harnesses - Electrical schematic sheet 24 (55.100)</b>
16	-	-		<b>Wiring harnesses - Electrical schematic sheet 25 (55.100)</b>
17	TR-7900 (LB)	From X-022 to <b>X-527</b>		
18	TR-7915 (VT)	From X-022 to <b>X-528</b>		
19	TR-7000P (BL)	From X-022 to TR-SP-7000		
20	-	-		
21	TR-7671A (BL)	From X-022 to <b>X-533</b>		
22	TR-7672A (RD)	From X-022 to <b>X-533</b>		
23	-	-		
24	TR-7220 (GY)	From X-022 to <b>X-536</b>		
25	TR-3295 (OR)	From X-022 to <b>X-259</b>		
26	-	-		
27	TR-7775 (PK)	From X-022 to <b>X-547</b>		
28	TR-7760A (WH)	From X-022 to <b>X-289</b>		
29	TR-9035 (TN)	From X-022 to <b>X-545</b>		
30	TR-7586 (BR)	From X-022 to <b>X-654</b>		
31	-	-		
32	TR-5097A (PK)	From X-022 to <b>X-269</b>		
33	TR-5090A (PK)	From X-022 to <b>X-269</b>		
34	TR-5087A (PK)	From X-022 to <b>X-268</b>		
35	TR-5085A (PK)	From X-022 to <b>X-268</b>		
36	TR-5070A (TN)	From X-022 to <b>X-266</b>		
37	TR-5075 (PK)	From X-022 to TR-SP-5075		
38	TR-5065A (TN)	From X-022 to <b>X-256</b>		
39	-	-		
40	TR-9010 (WH)	From X-022 to X-998		
41	-	-		
42	-	-		
43	-	-		
44	TR-7431 (LB)	From X-022 to <b>X-527</b>		
45	TR-7785 (OR)	From X-022 to <b>X-546</b>		
46	TR-5080 (PK)	From X-022 to <b>X-267</b>		
47	TR-5020A (TN)	From X-022 to TR-SP-5020		
48	-	-		
49	TR-2050AV (GN)	From X-022 to TR-SP-2050		
50	TR-9000 (BR)	From X-022 to <b>X-321</b>		
51	TR-7589 (BL)	From X-022 to <b>X-549</b>		

T7.175, T7.190, T7.210 – Standard

CONNECTOR X-053 - On harness 47841698			
PIN NUMBER	WIRE NUMBER	CIRCUIT REFERENCE	ELECTRICAL SCHEMATIC FRAME
A1	CM-3009A (GN)	From X-053 to CM-SP-3009	Wiring harnesses - Electrical schematic sheet 35 (55.100)
A2	CM-3004E (VT)	From X-053 to CM-SP-3004E	
A3	CM-349 (GN)	From X-053 to <b>X-020</b>	
A4	CM-3005E (VT)	From X-053 to CM-SP-3005E	
A5	CM-350 (YE)	From X-053 to <b>X-020</b>	
A6	CM-1020 (GN)	From X-053 to <b>X-007</b>	
A7	CM-1034 (LG)	From X-053 to <b>X-009</b>	
A8	CM-3000AB (GN)	From X-053 to CM-SP-3000	
B1	CM-3009B (GN)	From X-053 to CM-SP-3009	
B2	CM-3002 (GN)	From X-053 to <b>X-004</b>	
B3	CM-3001 (GN)	From X-053 to <b>X-004</b>	
B4	CM-1020B (GN)	From X-053 to CM-SP-1020	
B5	CM-1033 (LG)	From X-053 to <b>X-009</b>	
B6	CM-3005A (GN)	From X-053 to CM-SP-3005	
B7	CM-3004C (GN)	From X-053 to CM-SP-3004	
B8	CM-057BG (BK)	From X-053 to CM-SP-057E	
C1	CM-049A (GN)	From X-053 to <b>X-689</b>	
C2	CM-050A (GN)	From X-053 to <b>X-688</b>	
C3	CM-1039 (LG)	From X-053 to <b>X-094</b>	
C4	-	-	
C5	-	-	
C6	-	-	
C7	CM-057GZ (BK)	From X-053 to CM-SP-057E	
C8	CM-057KH (BK)	From X-053 to CM-SP-057E	

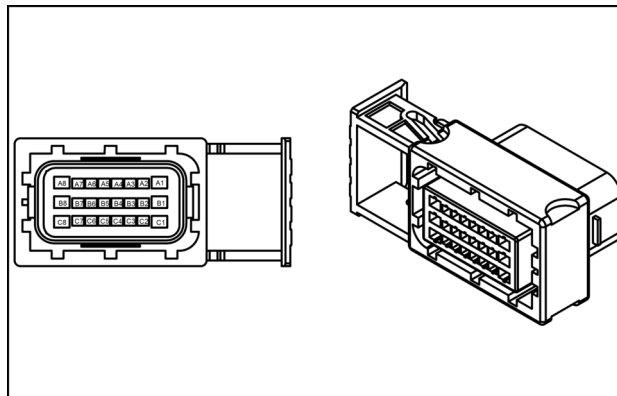

87680366 5

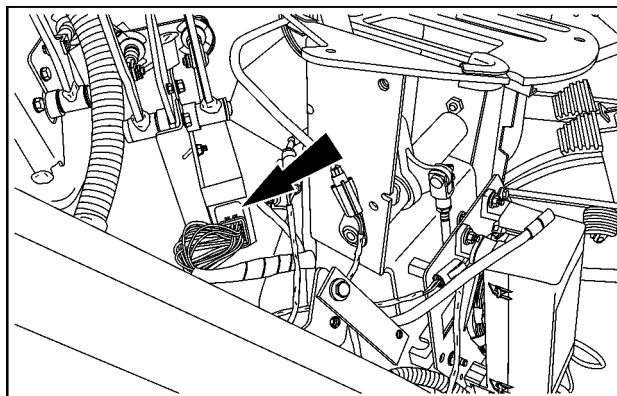

SVIL15TR00408AA 6

Behind right-hand side trim top of the fuse box

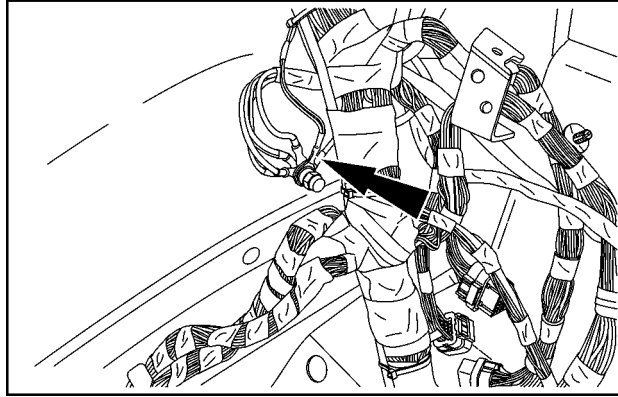

SVIL15TR00465AA 14

**Behind right-hand side trim**

**CONNECTOR X-097 - Central Control Unit**

**T7.175, T7.190, T7.210 – Standard**

<b>CONNECTOR X-097 - On harness 47841698</b>			
<b>PIN NUMBER</b>	<b>WIRE NUMBER</b>	<b>CIRCUIT REFERENCE</b>	<b>ELECTRICAL SCHEMATIC FRAME</b>
1	CM-4101 (LB)	From X-097 to CM-SP-4101	<b>Wiring harnesses - Electrical schematic sheet 08 (55.100)</b> <b>Wiring harnesses - Electrical schematic sheet 15 (55.100)</b> <b>Wiring harnesses - Electrical schematic sheet 16 (55.100)</b> <b>Wiring harnesses - Electrical schematic sheet 17 (55.100)</b> <b>Wiring harnesses - Electrical schematic sheet 18 (55.100)</b> <b>Wiring harnesses - Electrical schematic sheet 19 (55.100)</b>
2	CM-5580 (BL)	From X-097 to <b>X-083</b>	
3	CM-5585 (YE)	From X-097 to <b>X-083</b>	
4	-	-	
5	CM-5640 (RD)	From X-097 to <b>X-066</b>	
6	CM-3169 (OR)	From X-097 to <b>X-623A</b>	
7	-	-	
8	CM-2012AA (YE)	From X-097 to <b>X-020</b>	
9	CM-2069 (OR)	From X-097 to <b>X-081</b>	
10	CM-3014C (RD)	From X-097 to CM-SP-3014	
11	CM-7770 (BL)	From X-097 to <b>X-022</b>	
12	CM-6620 (BR)	From X-097 to <b>X-066</b>	
13	-	-	
14	CM-7960 (WH)	From X-097 to <b>X-022</b>	
15	-	-	
16	-	-	
17	CM-8050 (RD)	From X-097 to <b>X-022</b>	
18	CM-57ZNB (YE)	From X-097 to <b>X-2000</b>	
19	-	-	
20	CM-7430A (YE)	From X-097 to <b>X-002</b>	
21	CM-5830 (RD)	From X-097 to <b>X-020</b>	
22	-	-	
23	CM-7476 (RD)	From X-097 to <b>X-066</b>	
24	CM-5835 (GY)	From X-097 to <b>X-681</b>	
25	CM-5840 (WH)	From X-097 to <b>X-684</b>	
26	-	-	

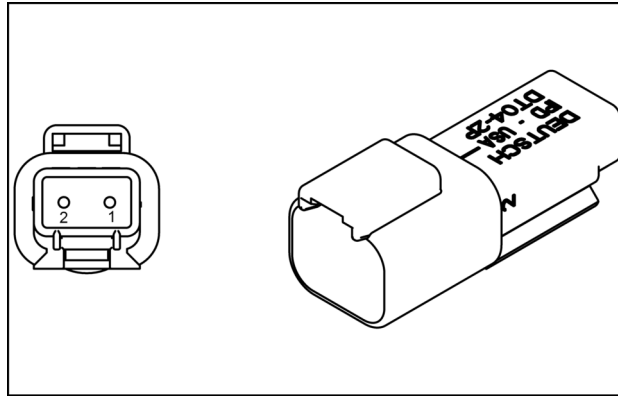

87695584 5

**CONNECTOR X-165 - Front work light right-hand**

T7.175, T7.190, T7.210, T7.225 AutoCommand  
T7.175, T7.190, T7.210

CONNECTOR X-165 - On harness 47754459			
PIN NUMBER	WIRE NUMBER	CIRCUIT REFERENCE	ELECTRICAL SCHEMATIC FRAME
1	RF-1098D (VT)	From X-165 to RF-SP-1098A	Wiring harnesses - Electrical schematic sheet 40 (55.100)
2	RF-057AA (BK)	From X-165 to RF-SP-57A	

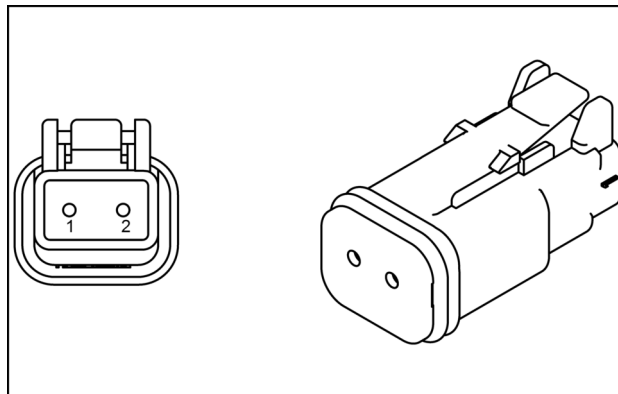

87695582 6

**CONNECTOR X-165B - Front work light right-hand**

T7.175, T7.190, T7.210, T7.225 AutoCommand  
T7.175, T7.190, T7.210

CONNECTOR X-165B - On harness 47754459			
PIN NUMBER	WIRE NUMBER	CIRCUIT REFERENCE	ELECTRICAL SCHEMATIC FRAME
1	RF-1098CA (VT)	From X-165B to RF-SP-1098A	Wiring harnesses - Electrical schematic sheet 40 (55.100)
2	RF-057WB (BK)	From X-165B to RF-SP-57A	

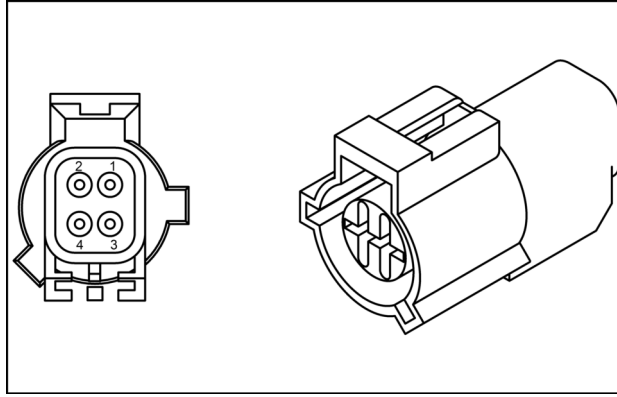

87712732 15

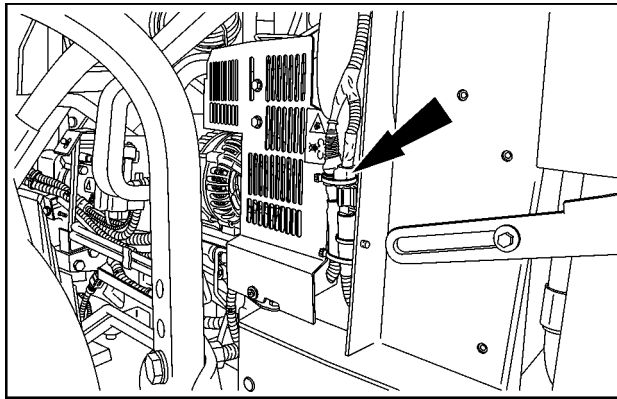

SVIL15TR00541AA 16

**Front right-hand side engine**

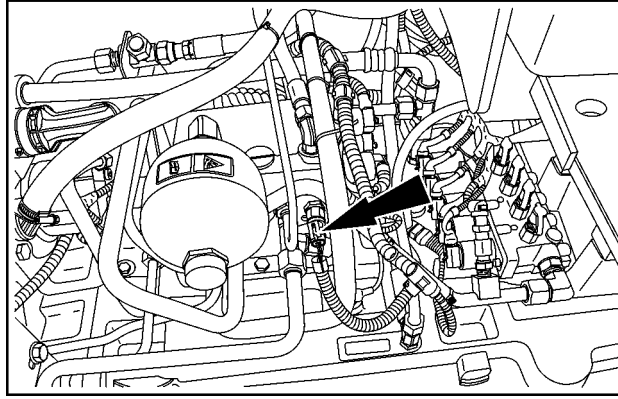

SVIL15TR00581AA 6

Right-hand side top of transmission

T7.175, T7.190, T7.210 – Standard [Semi Powershift transmission less Electro Hydraulic Remote (EHR) valves]

**CONNECTOR X-273 - On harness 84306448**

PIN NUMBER	WIRE NUMBER	CIRCUIT REFERENCE	ELECTRICAL SCHEMATIC FRAME
A	TR-60AY (BK/WH)	From X-273 to TR-SP-060	Wiring harnesses - Electrical schematic sheet 16 (55.100)
B	TR-5020 (TN)	From X-273 to TR-SP-5020	
C	TR-2012A (YE)	From X-273 to <b>X-020</b>	

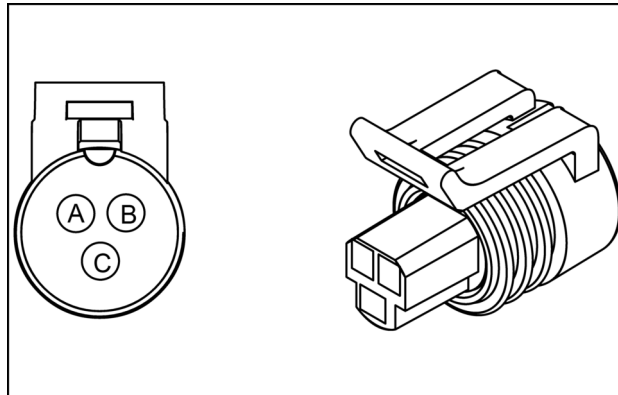

84078681 7

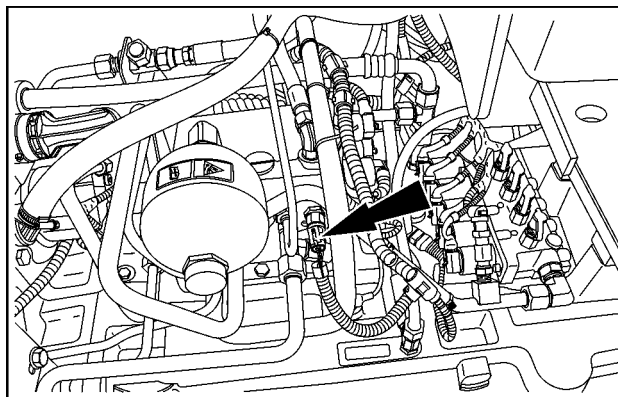

SVIL15TR00581AA 8

Right-hand side top of transmission

T7.175, T7.190, T7.210 – Sidewinder II [Powershift transmission with Electro Hydraulic Remote (EHR) valves]

**CONNECTOR X-273 - On harness 47663812**

PIN NUMBER	WIRE NUMBER	CIRCUIT REFERENCE	ELECTRICAL SCHEMATIC FRAME
A	TR-60BX1 (BK/WH)	From X-273 to TR-SP-0060	Wiring harnesses - Electrical schematic sheet 16 (55.100)
B	TR-5020B (GN)	From X-273 to TR-SP-5020	
C	TR-2012A (YE)	From X-273 to <b>X-020</b>	

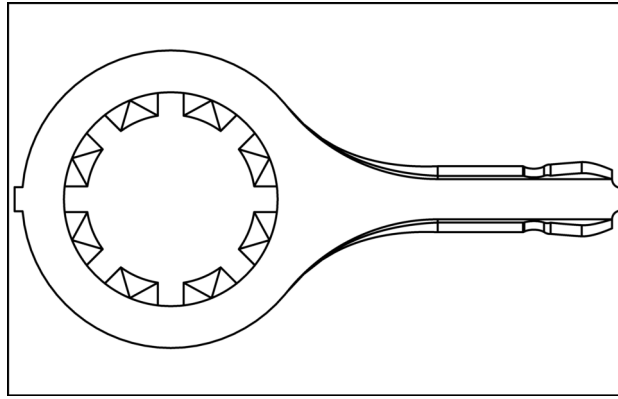

82012917 21

**T7.175, T7.190, T7.210 – Standard [Semi Powershift transmission less Electro Hydraulic Remote (EHR) valves]**

<b>CONNECTOR X-326-2 - On harness 84306448</b>			
<b>PIN NUMBER</b>	<b>WIRE NUMBER</b>	<b>CIRCUIT REFERENCE</b>	<b>ELECTRICAL SCHEMATIC FRAME</b>
1	TR-57EG (WH)	From X-326-2 to X-253	Wiring harnesses - Electrical schematic sheet 15 (55.100) Wiring harnesses - Electrical schematic sheet 16 (55.100) Wiring harnesses - Electrical schematic sheet 42 (55.100)

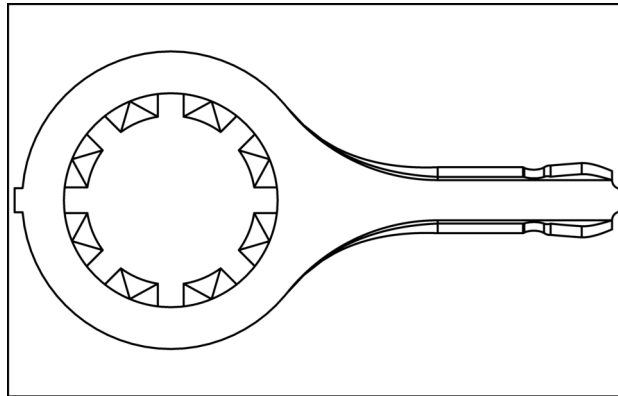

82012917 22

**T7.175, T7.190, T7.210 – Sidewinder II [Powershift transmission with Electro Hydraulic Remote (EHR) valves]**

<b>CONNECTOR X-326-2 - On harness 47663812</b>			
<b>PIN NUMBER</b>	<b>WIRE NUMBER</b>	<b>CIRCUIT REFERENCE</b>	<b>ELECTRICAL SCHEMATIC FRAME</b>
1	TR-57AA (BK)	From X-326-2 to TR-SP-0057A	Wiring harnesses - Electrical schematic sheet 15 (55.100) Wiring harnesses - Electrical schematic sheet 16 (55.100)

**CONNECTOR X-442 - Power supply pin socket (ground)**

T7.175, T7.190, T7.210, T7.225 AutoCommand  
 T7.175, T7.190, T7.210

CONNECTOR X-442 - On harness 82035388			
PIN NUMBER	WIRE NUMBER	CIRCUIT REFERENCE	ELECTRICAL SCHEMATIC FRAME
1	PO-057PT (BK)	From X-442 to X-117	Wiring harnesses - Electrical schematic sheet 34 (55.100)

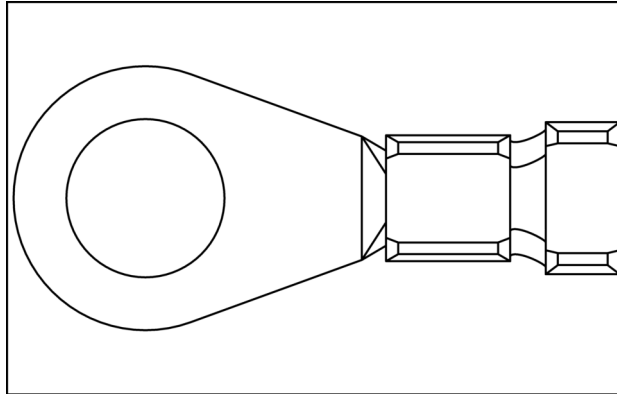

84149205 3

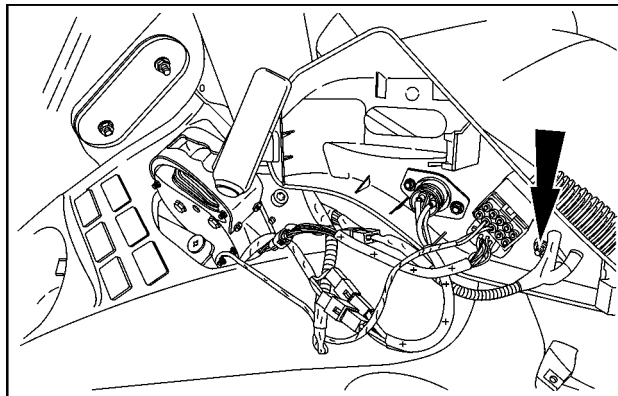

SVIL15TR00703AA 4

**Behind right-hand side switch panel**

## Wire connectors - Component diagram 60

**CONNECTOR X-600 - ISO bus implement socket (front) – Power supply**

T7.175, T7.190, T7.210, T7.225 AutoCommand

T7.175, T7.190, T7.210

CONNECTOR X-600 - On harness 47422915			
PIN NUMBER	WIRE NUMBER	CIRCUIT REFERENCE	ELECTRICAL SCHEMATIC FRAME
1	FI-057MT (BK)	From X-600 to FI-SP-057	Wiring harnesses - Electrical schematic sheet 49 (55.100)
2	FI-057MV (BK)	From X-600 to FI-SP-057	
3	FI-5985 (RD)	From X-600 to <b>X-629</b>	
4	FI-5975 (OR)	From X-600 to <b>X-628</b>	

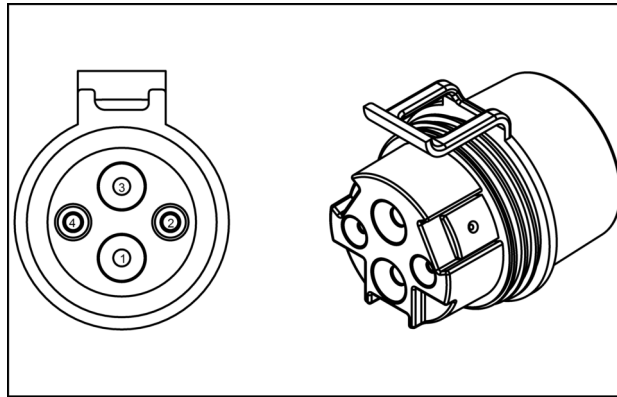

87533827 1

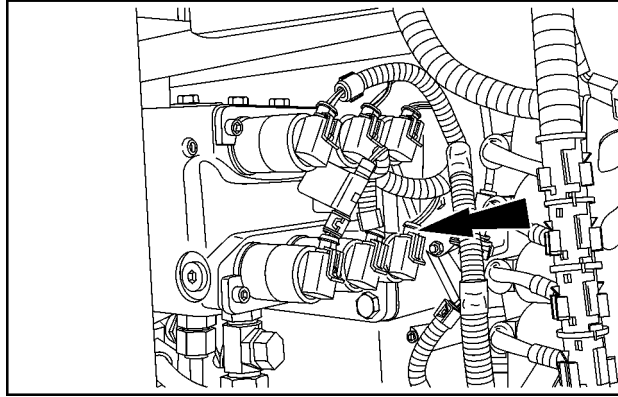

SVIL15TR01690AA 20

**Right-hand side of transmission**

**T7.175, T7.190, T7.210 – Sidewinder II [Powershift transmission with Electro Hydraulic Remote (EHR) valves]**

**CONNECTOR X-643 - On harness 47663812**

PIN NUMBER	WIRE NUMBER	CIRCUIT REFERENCE	ELECTRICAL SCHEMATIC FRAME
1	TR-7220AA (GY)	From X-643 to <b>X-022</b>	<b>Wiring harnesses - Electrical schematic sheet 16 (55.100)</b>
2	TR-57UE (BK)	From X-643 to TR-SP-0057	

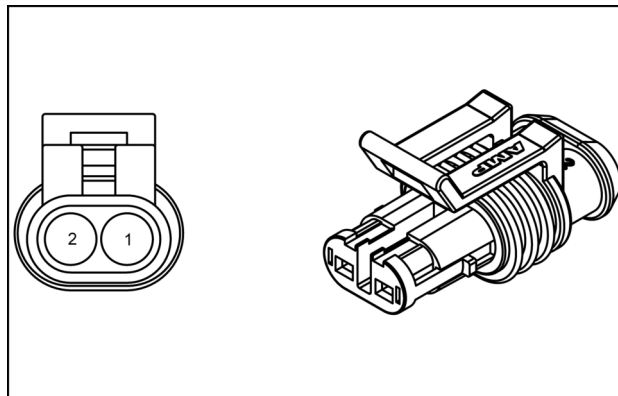

82012083 21

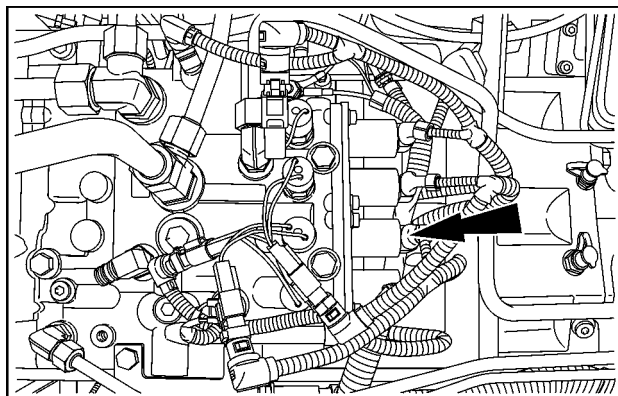

SVIL15TR01689AA 22

**Front top of transmission**

**T7.175, T7.190, T7.210 – Standard [Powershift transmission less Electro Hydraulic Remote (EHR) valves]**

**CONNECTOR X-643 - On harness 84306459**

PIN NUMBER	WIRE NUMBER	CIRCUIT REFERENCE	ELECTRICAL SCHEMATIC FRAME
1	TR-7220 (GY)	From X-643 to <b>X-022</b>	<b>Wiring harnesses - Electrical schematic sheet 16 (55.100)</b>
2	TR-7225 (WH)	From X-643 to <b>X-022</b>	

CLICK HERE TO **DOWNLOAD** THE COMPLETE MANUAL

- Thank you very much for reading the preview of the manual.
- You can download the complete manual from: [www.heydownloads.com](http://www.heydownloads.com) by clicking the link below



- Please note: If there is no response to CLICKING the link, please download this PDF first and then click on it.

CLICK HERE TO **DOWNLOAD** THE COMPLETE MANUAL

**CONNECTOR X-712 - Autoguidance dump solenoid valve**

T7.175, T7.190, T7.210, T7.225 AutoCommand  
 T7.175, T7.190, T7.210

CONNECTOR X-712 - On harness 47645853			
PIN NUMBER	WIRE NUMBER	CIRCUIT REFERENCE	ELECTRICAL SCHEMATIC FRAME
1	AS-3168 (OR)	From X-712 to X-710	Wiring harnesses - Electrical schematic sheet 27 (55.100)
2	AS-3169 (BK)	From X-712 to X-710	

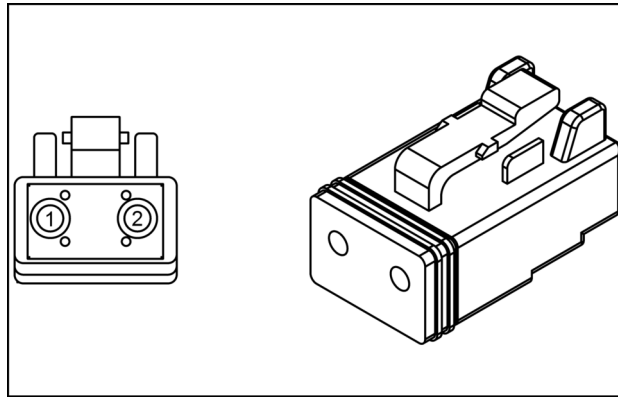

87711966 11

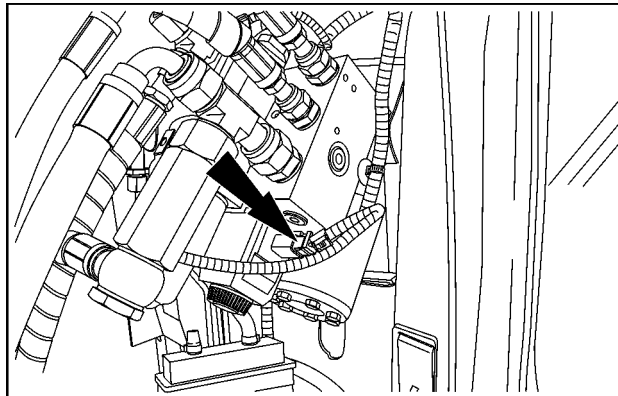

SVIL15TR01747AA 12

**Rear top left-hand side engine**

CONNECTOR X-773			
PIN NUMBER	WIRE NUMBER	CIRCUIT REFERENCE	ELECTRICAL SCHEMATIC FRAME
A	(RD)	-	Wiring harnesses - Electrical schematic sheet 29 (55.100)
B	(BK/WH)	-	

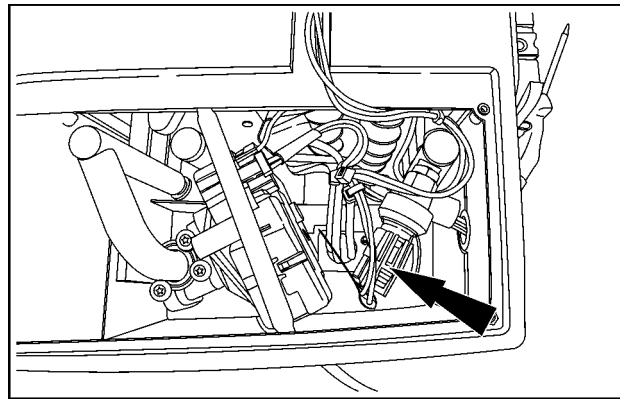
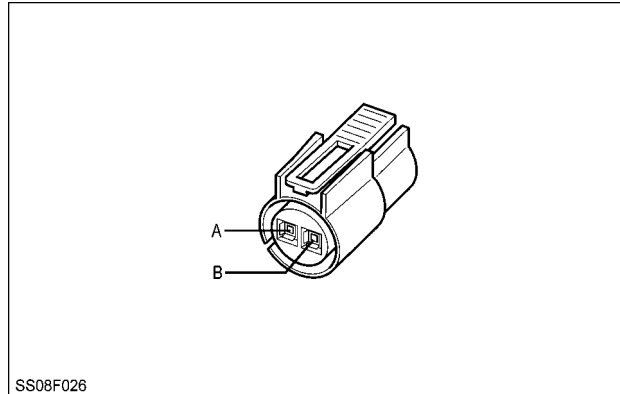

In cab below operator's seat

**CONNECTOR X-774 - Heating control valve**

T7.175, T7.190, T7.210, T7.225 AutoCommand [Standard climate control]

T7.175, T7.190, T7.210 [Standard climate control]

CONNECTOR X-774			
PIN NUMBER	WIRE NUMBER	CIRCUIT REFERENCE	ELECTRICAL SCHEMATIC FRAME
A	(RD)	-	Wiring harnesses - Electrical schematic sheet 29 (55.100)
C	(YE)	-	
D	(BK)	-	Wiring harnesses - Electrical schematic sheet 30 (55.100)

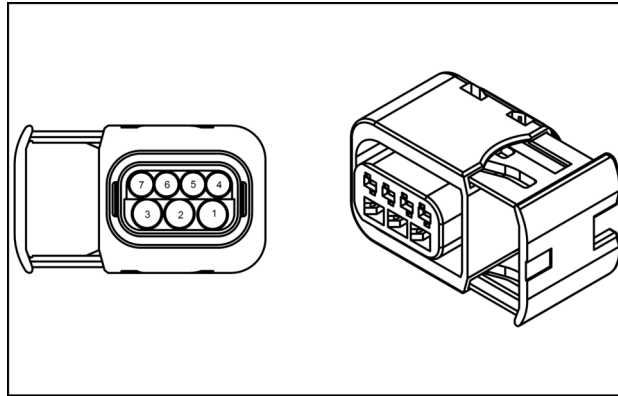

84152563 12

**CONNECTOR X-898 - Battery isolator**

T7.175, T7.190, T7.210, T7.225 AutoCommand  
 T7.175, T7.190, T7.210

CONNECTOR X-898 - On harness 47725732			
PIN NUMBER	WIRE NUMBER	CIRCUIT REFERENCE	ELECTRICAL SCHEMATIC FRAME
1	RI1-150AS (RD)	From X-898 to X-608	Wiring harnesses - Electrical schematic sheet 10 (55.100)

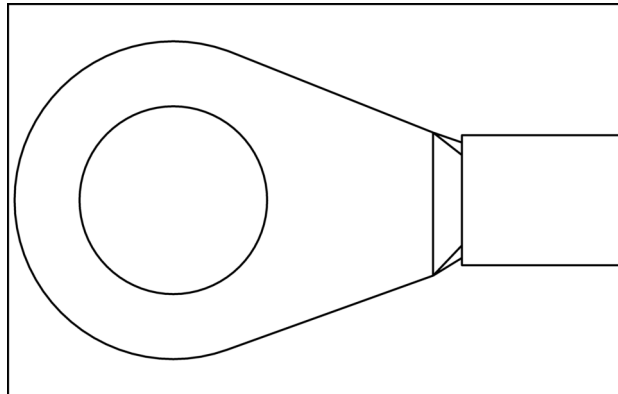

84155455 13

Electrical systems - Harnesses and connectors

Relay	Description
K-016	Work light C-pillar – Relay
K-017	Ignition relay 2 (switched battery power supply)
K-018	Battery isolator relay
K-019	Air-conditioning compressor relay
K-020	Remote valve relay
K-057	Front work light relay
K-058	Rear work light relay
K-064	SCR auxiliary power supply relay

**Fuses**

Fuse	Ampere	Description
F-001	10 A	Cab interior light, Step light, Mirror heater
F-002	25 A	Cigarette lighter, Power socket 30 A – Cab inside (battery power supply)
F-003	10 A	Air-conditioning compressor – Magnetic clutch
F-004	10 A	Power supply pin socket
F-005	30 A	Blower motor
F-006	10 A	Radio, Work light switch panel
F-007	20 A	High beam headlights, Hazard warning light, Horn
F-008	20 A	Ignition switch
F-009	25 A	Front loader power supply
F-010	30 A	Power socket 40 A – Cab outside (switched battery power supply)
F-011	15 A	Front window wiper motor
F-012	10 A	Rear window wiper motor, Wiper/Washer system (front and rear)
F-013	15 A	Brake light
F-014	15 A	Main light switch, A-pillar headlight switch, Flasher unit
F-015	20 A	Electronic Park Lock (EPL) controller, Brake light, Exhaust brake switch, Pneumatic trailer brake relay
F-016	15 A	Electronic Park Lock (EPL) controller, Trailer brake
F-017	25 A	Power socket 30 A – Cab inside (switched battery power supply)
F-018	15 A	Blower motor relay, Seat compressor, Seat heater
F-019	15 A	Mirror heater, Instrument cluster keypad, Implement signal socket (ISO 11786), Radar sensor
F-020	25 A	Electronic Park Lock (EPL) controller
F-021	7.5 A	Brake fluid level switch
F-022	10 A	Position light right-hand, Transmission display, Position light right-hand – Trailer socket rear and front (7-Pin)
F-023	10 A	Position light left-hand, Licence plate lights, Position light left-hand – Trailer socket rear and front (7-Pin)
F-024	7.5 A	Instrument cluster, Cigarette lighter, Monitor bar, Mirror heating switch – Lighting
F-025	15 A	Low beam headlights, Follow me home
F-026	15 A	Main beam headlights
F-027	30 A	Engine hood work lights
F-028	15 A	Rear work lights
F-029	15 A	Front work lights, A-pillar work lights
F-030	15 A	Rear work lights C-pillar
F-031	10 A	Rotating beacon
F-032	20 A	Flasher unit
F-033	20 A	Diagnostic socket (CAN bus 1 and 4, 2 and 3) – Permanent battery power supply
F-034	10 A	Instrument cluster, Hand brake position switch
F-035	10 A	Central Control Unit, Auxiliary Control Unit (ACU), Color display (on bracket), ISO bus interface controller (TECU) – Permanent battery power supply
F-036	10 A	Instrument cluster (switched battery power supply)



## Controller Identifier Code Table

The controller is identified with a two letter code, i.e. HX - Enhanced ADIC.

Identifier	Controller
HX	Enhanced Analogue Digital Instrument Cluster (ADIC)
HY	Basic ADIC
JA	Enhanced Keypad
KA	Fast Steer System
OA	Tractor ECU
RY	FPS Central Control Unit
RZ	SPS Central Control Unit
RK	Auxiliary Control Unit
XA	Electronic Park Lock

With the diagnostic test switch, special tool **380000843** located in the tractor diagnostic connector key on the ignition. The dot matrix display and lower central display will show the HH Menu entry.

The left arrow (1) and the right arrow (2) indicate that there are other controllers available.

To navigate through the list of controllers use the "h" button to scroll left and the "m" button to scroll right. Once the display shows the desired module it should be confirmed by pressing the dimming key.

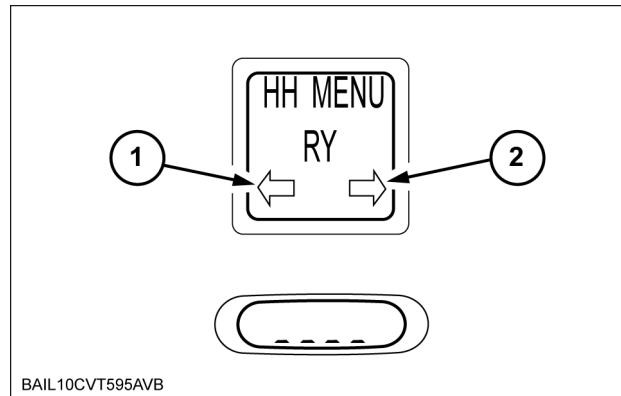

BAIL10CVT595AVB 5

If a controller cannot be found on the CAN, an error symbol will be displayed indicating there is no communication between the instrument cluster and the selected controller.

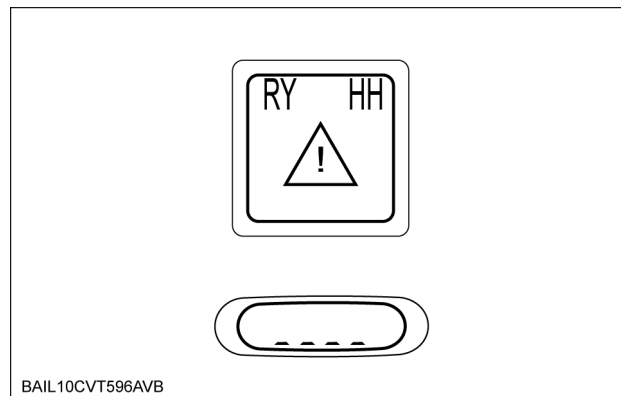

BAIL10CVT596AVB 6

Scroll through the available options, depress the "dimming" button to select the desired controller. The display will change to show the "HH menu" selection screen. The left and right arrows indicate there are other controllers available.

To navigate through the list of controllers use the "h" button to scroll left and the "m" button to scroll right. The down arrow indicates a subsystem menu is also available.

T7.175, T7.190, T7.210 – Powershift transmission

**Component Identification**

No.	Description
1.	Universal controller
2.	Hydraulic master switch
3.	Electronic Draft Control (EDC)
4.	Transmission control (FPS)
5.	Rear Power Take-Off (PTO) control
6.	Four Wheel Drive (4WD), Differential lock control
16.	Sensor ground 1
17.	Sensor ground 2
18.	Power ground

**Controller and CAN bus cross-references**

Controller / CAN bus	Schematic reference
ARU	Electronic module Armrest control unit (ARU) - Electronic schema (55.640)
ATC	Automatic Temperature Control (ATC) module - Electronic schema (55.050)
ECU	Engine Control Unit (ECU) - Electronic schema (55.015)
EHR	Remote control valve control unit - Electronic schema (55.035)
EPL	Electronic park lock actuator/controller - Electronic schema (55.031)
ICU	Electronic module Instrument control unit - Electronic schema (55.640)
CAN bus 1	Wiring harnesses - Electrical schematic sheet 51 (55.100)
CAN bus 2	Wiring harnesses - Electrical schematic sheet 53 (55.100)
CAN bus 3	Wiring harnesses - Electrical schematic sheet 54 (55.100)
CAN bus	Controller Area Network (CAN) data bus - Overview (55.640)

Use the "h" and "m" buttons to toggle between the available options:

"Yes" - Enable front PTO

"No" - Disable front PTO

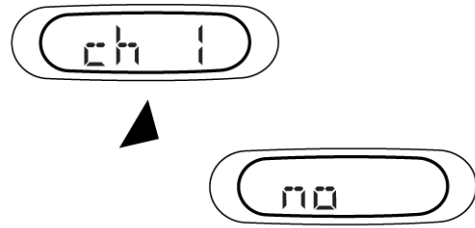

BAIL06CCM506AVA

BAIL06CCM506AVA 14

To save the desired option, depress and hold the "h" or "m" button until the instrument cluster bleeps, indicating that the selection has been saved.

**NOTE:** The default value on a new module is "no".

Depress the "dimming" button to continue navigating through the "HH" menus.

## Channel 2- Front Power Take-Off (PTO) management options

This channel is used to select whether the front PTO management option is enabled or disabled.

Use the "h" and "m" buttons to toggle between the available options:

"Yes" - Enable front PTO management option

"No" - Disable front PTO management option

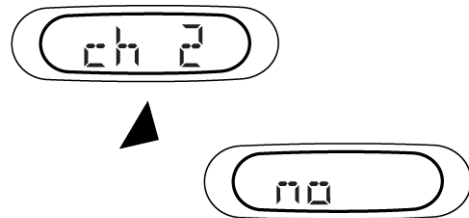

BAIL06CCM582AVA

BAIL06CCM582AVA 15

To save the desired option, depress and hold the "h" or "m" button until the instrument cluster bleeps, indicating that the selection has been saved.

**NOTE:** The default value on a new module is "no".

Depress the "dimming" button to continue navigating through the "HH" menus.

## Rear Power Take-Off (PTO) calibration values

Install the diagnostic connector **380000843** into the diagnostic socket.

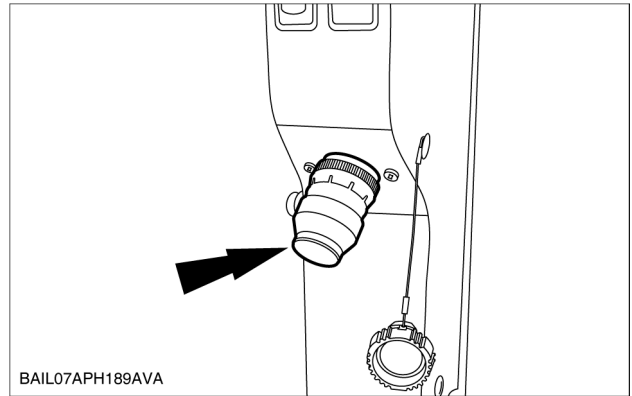

BAIL07APH189AVA 7

Turn the ignition key switch ON.

Use the "h", "m" and "dimming" buttons on the instrument cluster to navigate the HH menus to H2 and the rear PTO symbol on the R1 controller.

The lower central display will show "ch \_"

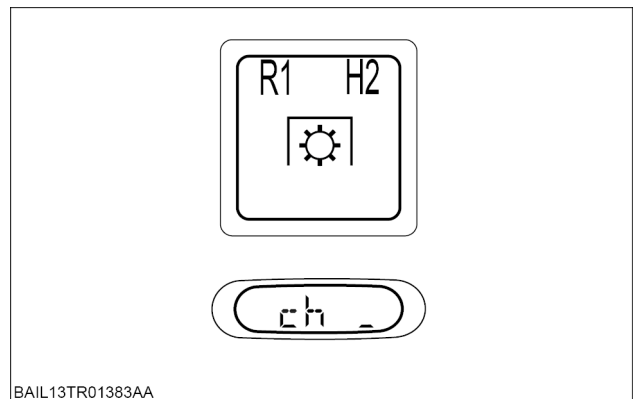

BAIL13TR01383AA 8

The required channel can be selected by using the "h" and "m" buttons.

After displaying the channel number, the calibration value for that channel will then be shown, (refer to the table below for a description of each channel).

Channel Number	Parameter	Typical Values
Ch 1	Rear PTO oil temperature (live)	Temperature dependent
Ch 2	Rear PTO solenoid calibration value	100 to 420

**NOTE:** The Rear PTO solenoid calibration value displayed in channel 2 is as a result of an automatic calibration that is initiated when the PTO is started.

Depress the "dimming" button to continue navigating the "HH" menus.

Use the "h", "m" and "dimming" buttons on the instrument cluster to navigate the HH menus to H7 on the R1 controller.

Select the H7 menu by depressing the "dimming" button.

The lower central display will show "ch \_"

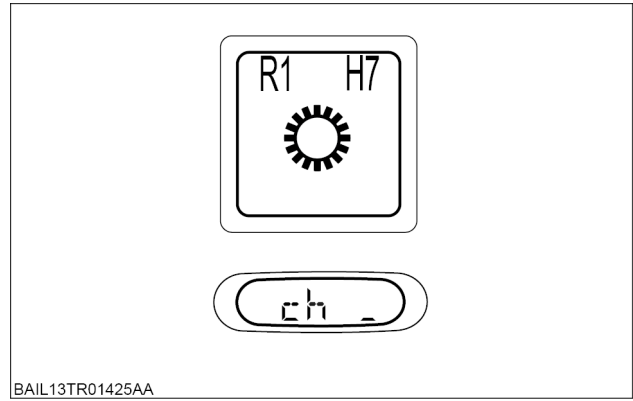

BAIL13TR01425AA 3

The required channel can be selected by using the "h" and "m" buttons.

After a delay the current option setting will be displayed, (refer to the table below for a description of each channel).

Channel Number	Description
Ch 1	Clutch switch adjustment
Ch 2	Manual clutch adjustment
Ch 3	Manual quickfill adjustment
Ch 4	Clutch pressure test
Ch 5	Clutch switch adjustment
Ch 6	Self bed in of clutches
Ch 7	PWM valve test

### Channel 1 - Clutch switch adjustment

**NOTE:** This channel is used to display the clutch pedal position and switch status. In addition it also displays the oil temperature.

The transmission is enabled in this state.

Shift the shuttle lever into the forward position. The clutch pedal position is displayed as a percentage of the travel (0-99), with 'O' or 'C' in the upper digit indicating whether the clutch pedal switch is open or closed. This is useful for evaluating the clutch pedal switch adjustment and also the inching bite point.

**NOTE:** The shuttle lever must be in the forward position for the clutch pedal switch status to change.

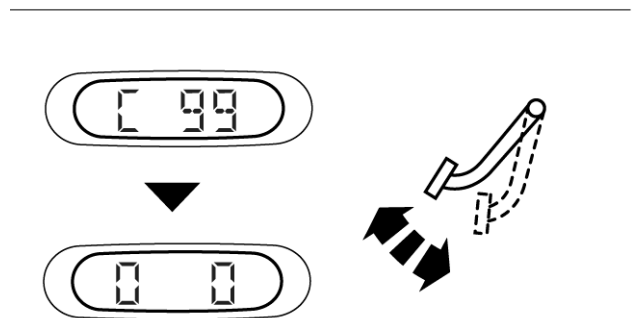

BAIL06CCM469AVA

BAIL06CCM469AVA 4

## Electronic module Instrument control unit - HF - View controller hardware information Enhanced Keypad (JA)

T7.175 AutoCommand™	ANZ --- APAC --- MEA
T7.175	ANZ --- APAC --- MEA
T7.190 AutoCommand™	ANZ --- APAC --- MEA
T7.190	ANZ --- APAC --- MEA
T7.210 AutoCommand™	ANZ --- APAC --- MEA
T7.210	ANZ --- APAC --- MEA

JA - Enhanced Keypad

**NOTE:** This menu makes possible hardware identification; the hardware version and serial number are displayed.

**NOTE:** Common to all sub-systems.

### HF Menu screen selection diagram

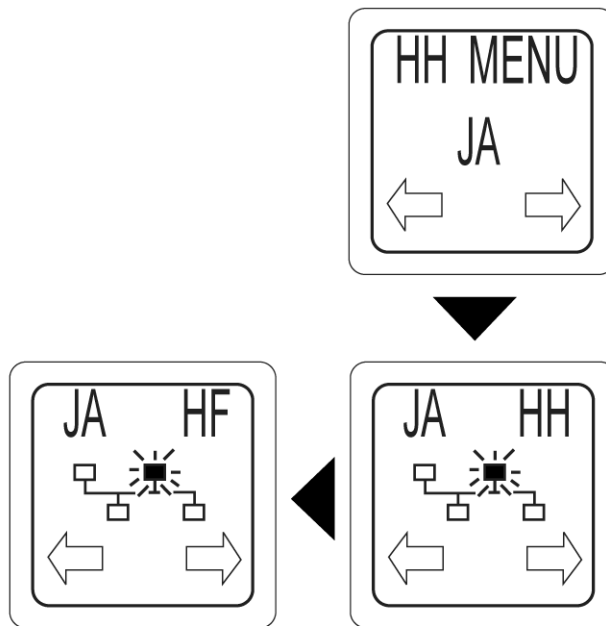

BAIL06CCM546FVB

BAIL06CCM546FVB 1

Install the diagnostic connector **380000843** into the diagnostic socket.

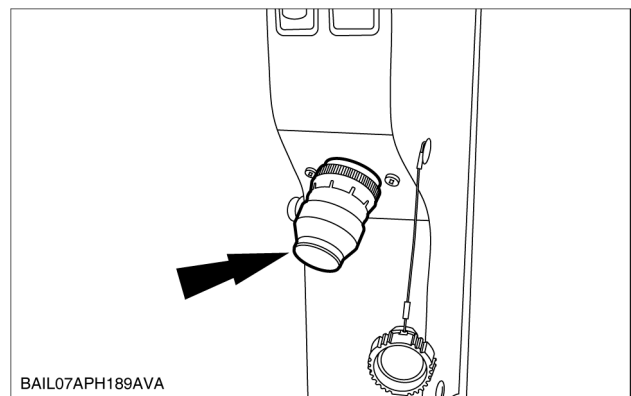

BAIL07APH189AVA 2

Turn the ignition key switch ON.

## Steering sensor calibration

**NOTE:** The calibration procedure is controlled by the electronic management system. To prevent inadvertent movement of the tractor, firmly apply the parking brake and block the rear wheels. Check that the ground speed display is zero before commencing.

**NOTE:** If the vehicle is fitted with IntelliSteer™ make sure that the steering angle sensor is connected to the main engine wiring harness rather than the AutoGuidance wiring harness during the calibration procedure. When calibration is complete the steering angle sensor should be reconnected to the AutoGuidance harness.

Install the diagnostic connector **380000843** into the diagnostic socket.

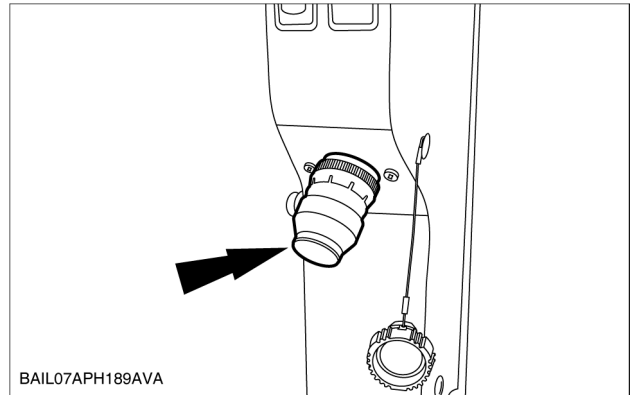

BAIL07APH189AVA 39

Start the engine.

Use the "h", "m" and "dimming" buttons on the instrument cluster to navigate the HH menus to H1 and the differential lock symbol on the U1 controller. The lower central display will show "CAL".

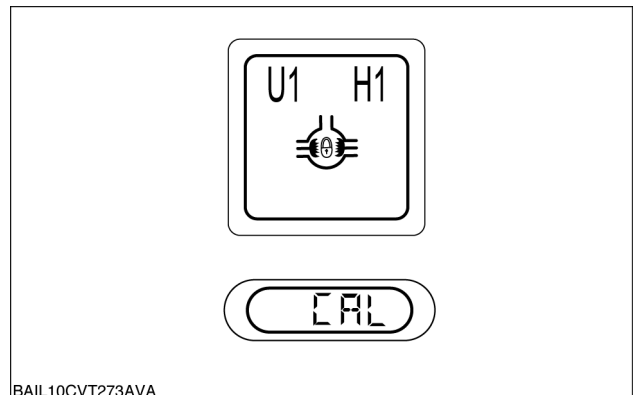

BAIL10CVT273AVA 40

Press and hold the Auto Difflock switch for 2 seconds.

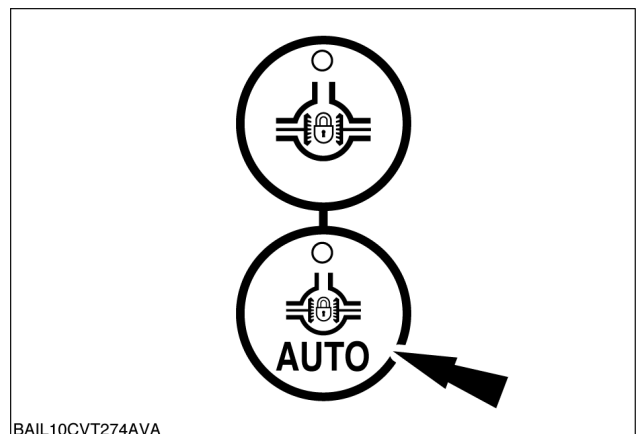

BAIL10CVT274AVA 41

Electrical systems - Electronic modules

Channel	Control unit plug connection	Pin number	Description
d13	CN2A	15	Right brake pedal switch
d15	CN4B	22	Shuttle lever forward switch
d16	CN4B	21	Shuttle lever reverse switch
d17	via CAN		Transmission downshift switch (on hand controller)
d18	via CAN		Transmission upshift switch (on hand controller)
d19	via CAN		Transmission range shift / 2nd function / Electro Hydraulic Remote valve (EHR) float switch (on hand controller)
d20	CN3A	17	Reverse clutch pressure switch (Full Powershift (FPS))
d21	CN3A	12	Forward clutch pressure switch (Full Powershift (FPS))
d23	CN2B	30	Shuttle lever forward / reverse switch
d24	CN2B	28	Shuttle lever neutral switch
d31	CN4B	14	Air conditioning pressure switch
d32	CN1B	15	Electronic Draft Control (EDC) enable switch
d33	CN1B	05	Radar present input (disconnect radar to test)
d38	via CAN	-	Manual differential lock switch
d39	via CAN	-	Auto differential lock switch
d41	via CAN	-	Manual four wheel drive switch
d42	via CAN	-	Auto four wheel drive switch
d43	CN2B	13	Hi-flow pump present input (disconnect pump link to test)
d44	CN2B	15	Rear Power Take-Off (PTO) switch - normally open
d45	CN3A	11	Rear Power Take-Off (PTO) switch - normally closed
d46	CN3B	11	Hi flow pump not present input
d47	CN4A	12	Rear Power Take-Off (PTO) brake switch
d49	via CAN	-	Rear Power Take-Off (PTO) management switch
d55	via CAN	-	Engine speed switch - decrease
d56	via CAN	-	Engine speed switch - Increase
d60	CN2B	24	Foot throttle not at idle switch
d63	CN2A	25	Rear Power Take-Off (PTO) fender switch (normally open)
d64	CN4A	10	Rear Power Take-Off (PTO) fender switch (normally closed)
d69	CN4A	25	Front suspension pressure switch
d74	CN4A	22	Exhaust brake switch
d75	via CAN	-	Side link extend switch
d76	via CAN	-	Side link retract switch
d77	CN4B	13	Front hitch fender switch present input
d78	CN3B	29	Front hitch external raise switch
d79	CN3B	30	Front hitch external lower switch
d84	via CAN		Front Power Take-Off (PTO) management switch
d89	via CAN	-	Front suspension lock switch
d90	CN4B	15	Front Power Take-Off (PTO) switch (normally open)
d91	CN4B	16	Front Power Take-Off (PTO) switch (normally closed)
d92	via CAN	-	Front hitch height limit switch
d94	CN2A	17	Electro Hydraulic Remote valve (EHR) enable switch
d95	via CAN	-	Electro Hydraulic Remote valve (EHR) 1 program / motor mode switch
d96	via CAN	-	Electro Hydraulic Remote valve (EHR) 2 program / motor mode switch
d97	via CAN	-	Electro Hydraulic Remote valve (EHR) 3 program / motor mode switch
d98	via CAN	-	Electro Hydraulic Remote valve (EHR) 4 program / motor mode switch
d105	via CAN	-	Auto function switch (on hand controller)
d107	CN2B	27	Electronic Shiftable Rear Power Take-Off (ESPTO) speed select switch - 540
d108	via CAN	-	Top link extend switch

Code	Description	Possible Failure
U07	Suspension is stationary during the raise command in the ACP procedure	<ol style="list-style-type: none"> <li>1) Check the raise solenoid harness</li> <li>2) Check the suspension mechanics</li> <li>3) Check the potentiometer linkage</li> <li>4) Check the pressure of the accumulators</li> <li>5) Check the hydraulic pressure</li> <li>6) Disconnect implement</li> </ol>
U08	Suspension unable to reach maximum height within 20 seconds	<ol style="list-style-type: none"> <li>1) Check the raise valve installation</li> <li>2) Check the unload solenoid installation</li> <li>3) Check the suspension mechanics</li> <li>4) Check the hydraulic pressure</li> <li>5) Disconnect implement</li> </ol>
U09	Suspension is stationary during the lowering command in the ACP procedure	<ol style="list-style-type: none"> <li>1) Check the unload solenoid harness</li> <li>2) Check the suspension mechanics</li> <li>3) Check the potentiometer linkage</li> <li>4) Check the hydraulic pressure</li> <li>5) Disconnect implement</li> </ol>
U10	Suspension unable to reach minimum height within 25 seconds	<ol style="list-style-type: none"> <li>1) Check unload solenoid installation</li> <li>2) Check the hydraulic pressure</li> <li>3) Disconnect implement</li> </ol>
U11	Unable to calibrate suspension	<ol style="list-style-type: none"> <li>1) The lockout switch was pressed more than 3 times to initiate calibration</li> <li>2) Check the suspension mechanics</li> <li>3) Check the hydraulic pressure</li> </ol>
U12	ACP stopped, vehicle not stationary	<ol style="list-style-type: none"> <li>1) Handbrake not applied</li> <li>2) Rear axle speed sensor faulty</li> </ol>
U19	Insufficient potentiometer range for optimal suspension performance	<ol style="list-style-type: none"> <li>1) Incorrect adjustment of front axle position potentiometer linkage</li> </ol>

This channel is used to select the front axle type, standard or **SuperSteer™**.

After a delay the current stored option will be displayed.

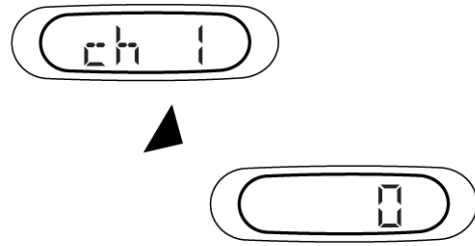

BAIL06CCM507AVA

BAIL06CCM507AVA 23

Use the "h" and "m" buttons to toggle between the available options:

"0" - Standard axle

"1" - **SuperSteer™** axle

**NOTE:** The default setting for this channel is "0".

Depress and hold the "m" button until the instrument cluster bleeps, indicating the selection has been stored.

### Channel 2 - Not used

This channel is not used and "--" will be displayed.

### Channel 3 - Terralock (front axle) angles

This channel is used to select the steering angle at which the auto differential lock and auto four wheel drive functions engage and disengage.

After a delay the current stored option will be displayed.

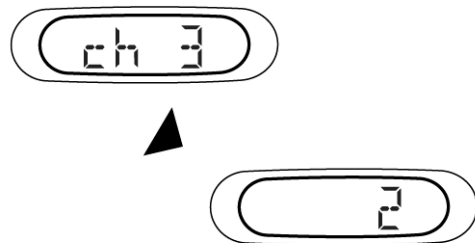

BAIL06CCM508AVA

BAIL06CCM508AVA 24

Use the "h" and "m" buttons to toggle between the available options, "0", "1", "2" or "3", refer to the table below for the steering angles that correspond to each option.

**NOTE:** There is **2 km/h** hysteresis on the vehicle speed.

The angles for each option are different depending on whether the front axle is Standard or **SuperSteer™**.

There is a **3 °** hysteresis on the standard axle Steering angle and a **1 °** hysteresis on the **SuperSteer™** steering angle.

In order for a test to commence the operator must be in the seat with the engine running, the handbrake applied and the shuttle lever in the Park position. The vehicle must be stationary and the clutch pedal released. If any of these conditions are not met a “U” code will be displayed, for a full list of “U” codes refer to **Electronic module - Fault code index (55.640)**.

The transmission oil temperature must be between **-10 - 90 °C (14 - 194 °F)** for the test to proceed. If the oil temperature is below **-10 °C (14 °F)** “Cold” will be displayed on the instrument cluster, if the temperature is above **90 °C (194 °F)** “hot” will be displayed.

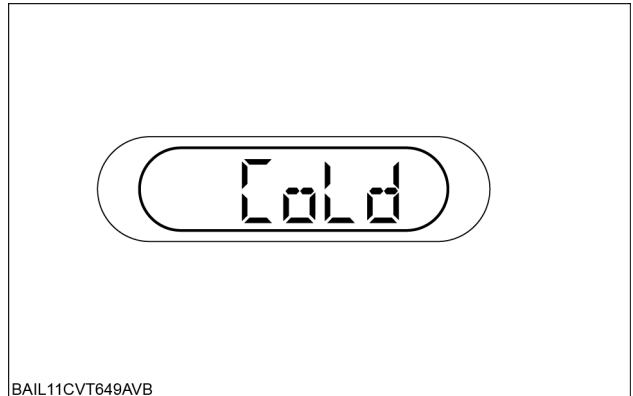

BAIL11CVT649AVB 11

If all the required conditions have been satisfied the oil temperature will be displayed on the instrument cluster, and the test can be started.

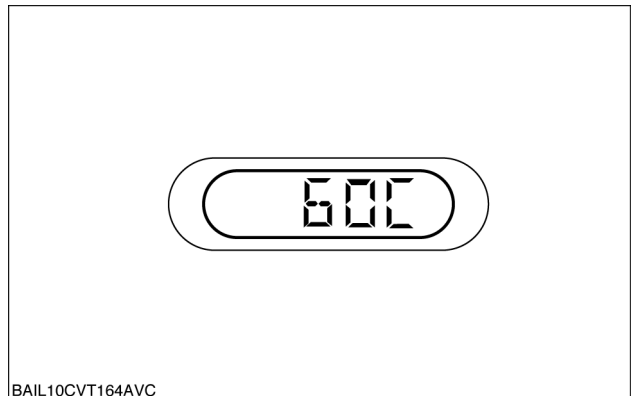

BAIL10CVT164AVC 12

Start the data logging on the EST. See below for instructions for setting up the EST for logging the test results.

Start the selected test by pressing the “Accel / Shuttle” button on the Instrument Control Panel (ICP).

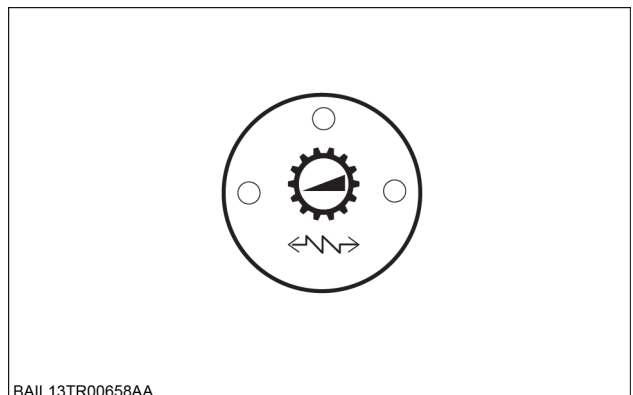

BAIL13TR00658AA 13

The engine speed will automatically be set to **2000 RPM**.

A count will be shown on the instrument cluster, increasing every two seconds until the test is complete.

# Contents

---

## Electrical systems - 55

### Transmission position sensors - 023

#### FUNCTIONAL DATA

##### Position sensors

Overview – F2/R1 .....	3
T7.175 AutoCommand™ --- ANZ --- APAC --- MEA, T7.190 AutoCommand™ --- ANZ --- APAC --- MEA, T7.210 AutoCommand™ --- ANZ --- APAC --- MEA, T7.225 AutoCommand™ --- ANZ --- APAC --- MEA	

#### SERVICE

##### Position sensors

Replace (F2/R1) .....	4
T7.175 AutoCommand™ --- ANZ --- APAC --- MEA, T7.190 AutoCommand™ --- ANZ --- APAC --- MEA, T7.210 AutoCommand™ --- ANZ --- APAC --- MEA, T7.225 AutoCommand™ --- ANZ --- APAC --- MEA	

If the value displayed varies by more than **10 %** to that shown in the table below, a fault is indicated in either the component or the wiring harness relevant to that channel.

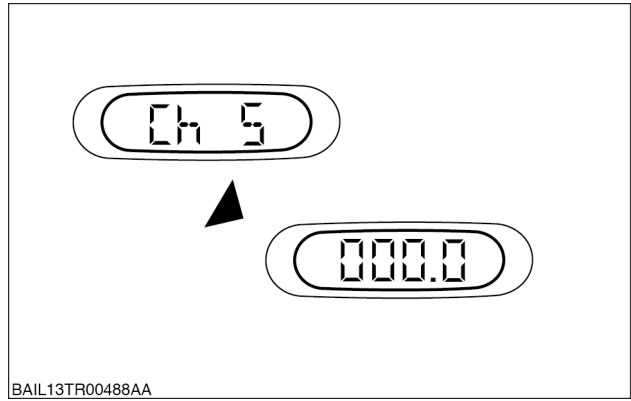

BAIL13TR00488AA 5

**NOTE:** Check the connectors of the effected circuit, including the controller connectors, prior to replacing any components.

Channel	Description	Typical reading
Ch 1	ASNS_AI_1 input	0 - 5 V ( 0.1 V resolution)
Ch 2	Shuttle lever park switch	0 - 5 V ( 0.1 V resolution)
Ch 3	Battery voltage	2.7 - 26.8 V ( 0.1 V resolution)
Ch 4	Ignition switch voltage	0 - 27.9 V ( 0.1 V resolution)
Ch 5	Accelerometer	-1.5 - 1.5 g ( 0.1 g resolution)
Ch 6	Temperature	-40 °C to 120 °C ( 1 °C resolution)

## Automatic Temperature Control (ATC) module - Remove

T7.175 AutoCommand™	ANZ Cab climate control - Auto Temperature Control (ATC) --- APAC Cab climate control - Auto Temperature Control (ATC) --- MEA Cab climate control - Auto Temperature Control (ATC)
T7.175	ANZ Cab climate control - Auto Temperature Control (ATC) --- APAC Cab climate control - Auto Temperature Control (ATC) --- MEA Cab climate control - Auto Temperature Control (ATC)
T7.190 AutoCommand™	ANZ Cab climate control - Auto Temperature Control (ATC) --- APAC Cab climate control - Auto Temperature Control (ATC) --- MEA Cab climate control - Auto Temperature Control (ATC)
T7.190	ANZ Cab climate control - Auto Temperature Control (ATC) --- APAC Cab climate control - Auto Temperature Control (ATC) --- MEA Cab climate control - Auto Temperature Control (ATC)
T7.210 AutoCommand™	ANZ Cab climate control - Auto Temperature Control (ATC) --- APAC Cab climate control - Auto Temperature Control (ATC) --- MEA Cab climate control - Auto Temperature Control (ATC)
T7.210	ANZ Cab climate control - Auto Temperature Control (ATC) --- APAC Cab climate control - Auto Temperature Control (ATC) --- MEA Cab climate control - Auto Temperature Control (ATC)
T7.225 AutoCommand™	ANZ Cab climate control - Auto Temperature Control (ATC) --- APAC Cab climate control - Auto Temperature Control (ATC) --- MEA Cab climate control - Auto Temperature Control (ATC)

1. Turn the ignition switch to the “OFF” position.
2. Remove the storage box (where fitted).
3. Remove the ball studs (1).

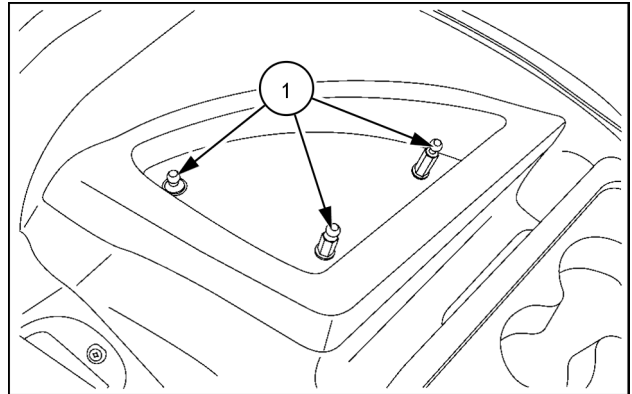

SVIL15TR00120AA 1

4. Carefully remove the seat cushion.  
**NOTE:** Use a screw driver to unlock the seat cushion.

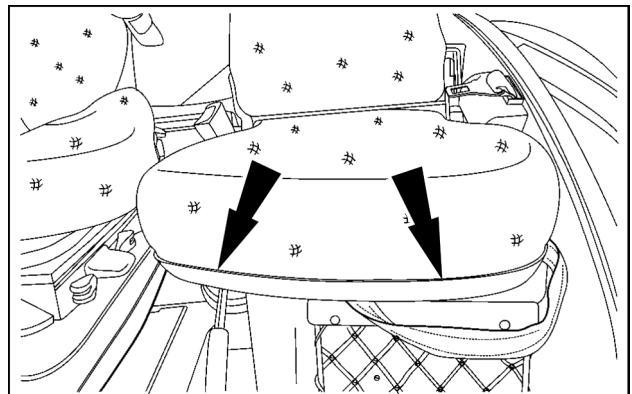

SVIL15TR00121AA 2

## Fast steering control module - H8 - Clear stored calibration information (EEPROM)

T7.175 AutoCommand™	ANZ --- APAC --- MEA
T7.175	ANZ --- APAC --- MEA
T7.190 AutoCommand™	ANZ --- APAC --- MEA
T7.190	ANZ --- APAC --- MEA
T7.210 AutoCommand™	ANZ --- APAC --- MEA
T7.210	ANZ --- APAC --- MEA

KA - Fast steer control module

**NOTE:** This menu clears calibration values and stored error codes by resetting all EEPROM values back to default.

**NOTE:** EEPROM is where all calibration values and error codes are stored. This memory is retained even if there is no power to the controller, i.e. if the battery is disconnected.

**NOTE:** In order to change any configuration settings the H3 menu must be used. These settings will be unaffected by performing an H8 operation.

**NOTE:** Use the HC menu if it is required to erase all stored error codes without erasing calibration information.



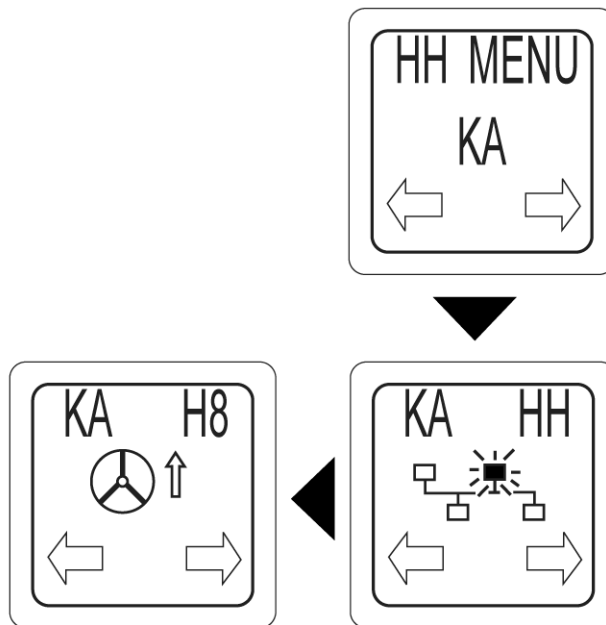









### H8 Menu screen select diagram



## Instrument cluster Analog-Digital Instrument Cluster (ADIC) - Detailed view – Transmission

T7.175, T7.190, T7.210, T7.225 AutoCommand™

T7.175, T7.190, T7.210 – Sidewinder II

Symbol on the display	Indicator light	Warning light	Acoustic warning	Cause	Signal
	-	-	Action required	The transmission oil is too cold. Heat up the transmission oil. See <b>Continuously Variable Transmission (CVT) - Dynamic description (21.504)</b> .	CAN bus message from UCM
<b>CP</b>	-	-	Action required	Operator seat switch is disengaged for more than <b>5 s</b> and the operator attempts to select a direction of travel. Press the clutch pedal once.	CAN bus message from UCM
<b>N</b>	-	-	Action required	Direction of travel selected. A request to shift into the NEUTRAL position.	CAN bus message from UCM
	-	 flashes  flashes	Non-critical  Critical	Engine overspeed due to a heavy trailer on a sloped road.	CAN bus message from UCM
	-	-	Safety	Rear Power Take-Off (PTO) engaged, operator not present.	CAN bus message from UCM
<b>F</b> 	-	-	Safety	Front Power Take-Off (PTO) engaged, operator not present.	CAN bus message from UCM
	-	 flashes	Non-critical	Incorrect operation of Power Take-Off (PTO): Time exceeded, Power Take-Off (PTO) switch was actuated within <b>2 s</b> in the cab and on the fender. After <b>10 s</b> normal function is possible again.	CAN bus message from UCM
	-	 flashes	Non-critical	Power Take-Off (PTO) Anti-Stall: (Engine stalling protection) Engine speed too low when Power Take-Off (PTO) is switched on with heavy attached implements or change switch-off speed. (Symbol <b>4 s</b> then back to normal screen).	CAN bus message from UCM (Symbol appears for <b>4 s</b> then back to the normal screen)
	-	 flashes <b>4 s</b> and then illuminates permanently	Non-critical	Wheel slip exceeds the set limit value.	CAN bus message from UCM

10001-Upper lockout solenoid error [ACU] .....	1192
T7.175 Standard [ZFEN30001 - ] --- ANZ --- APAC --- MEA, T7.190 Standard [ZFEN30001 - ] --- ANZ --- APAC --- MEA, T7.210 Standard [ZFEN30001 - ] --- ANZ --- APAC --- MEA	
10001-Upper lockout solenoid error [UCM] .....	1193
T7.175 AutoCommand™ --- ANZ --- APAC --- MEA, T7.175 Sidewinder II [ZFEN30001 - ] --- ANZ --- APAC --- MEA, T7.190 AutoCommand™ --- ANZ --- APAC --- MEA, T7.190 Sidewinder II [ZFEN30001 - ] --- ANZ --- APAC --- MEA, T7.210 AutoCommand™ --- ANZ --- APAC --- MEA, T7.210 Sidewinder II [ZFEN30001 - ] --- ANZ --- APAC --- MEA, T7.225 AutoCommand™ --- ANZ --- APAC --- MEA	
10002-Raise solenoid error [ACU] .....	1195
T7.175 Standard [ZFEN30001 - ] --- ANZ --- APAC --- MEA, T7.190 Standard [ZFEN30001 - ] --- ANZ --- APAC --- MEA, T7.210 Standard [ZFEN30001 - ] --- ANZ --- APAC --- MEA	
10002-Raise solenoid error [UCM] .....	1196
T7.175 AutoCommand™ --- ANZ --- APAC --- MEA, T7.175 Sidewinder II [ZFEN30001 - ] --- ANZ --- APAC --- MEA, T7.190 AutoCommand™ --- ANZ --- APAC --- MEA, T7.190 Sidewinder II [ZFEN30001 - ] --- ANZ --- APAC --- MEA, T7.210 AutoCommand™ --- ANZ --- APAC --- MEA, T7.210 Sidewinder II [ZFEN30001 - ] --- ANZ --- APAC --- MEA, T7.225 AutoCommand™ --- ANZ --- APAC --- MEA	
10003-Lower solenoid error [ACU] .....	1198
T7.175 Standard [ZFEN30001 - ] --- ANZ --- APAC --- MEA, T7.190 Standard [ZFEN30001 - ] --- ANZ --- APAC --- MEA, T7.210 Standard [ZFEN30001 - ] --- ANZ --- APAC --- MEA	
10003-Lower solenoid error [UCM] .....	1199
T7.175 AutoCommand™ --- ANZ --- APAC --- MEA, T7.175 Sidewinder II [ZFEN30001 - ] --- ANZ --- APAC --- MEA, T7.190 AutoCommand™ --- ANZ --- APAC --- MEA, T7.190 Sidewinder II [ZFEN30001 - ] --- ANZ --- APAC --- MEA, T7.210 AutoCommand™ --- ANZ --- APAC --- MEA, T7.210 Sidewinder II [ZFEN30001 - ] --- ANZ --- APAC --- MEA, T7.225 AutoCommand™ --- ANZ --- APAC --- MEA	
10004-Front axle position sensor - threshold higher than set limit [ACU] .....	1201
T7.175 Standard [ZFEN30001 - ] --- ANZ --- APAC --- MEA, T7.190 Standard [ZFEN30001 - ] --- ANZ --- APAC --- MEA, T7.210 Standard [ZFEN30001 - ] --- ANZ --- APAC --- MEA	
10004-Front axle position sensor - threshold higher than set limit [UCM] .....	1203
T7.175 AutoCommand™ --- ANZ --- APAC --- MEA, T7.175 Sidewinder II [ZFEN30001 - ] --- ANZ --- APAC --- MEA, T7.190 AutoCommand™ --- ANZ --- APAC --- MEA, T7.190 Sidewinder II [ZFEN30001 - ] --- ANZ --- APAC --- MEA, T7.210 AutoCommand™ --- ANZ --- APAC --- MEA, T7.210 Sidewinder II [ZFEN30001 - ] --- ANZ --- APAC --- MEA, T7.225 AutoCommand™ --- ANZ --- APAC --- MEA	
10005-Front axle position sensor – threshold lower than set limit [ACU] .....	1205
T7.175 Standard [ZFEN30001 - ] --- ANZ --- APAC --- MEA, T7.190 Standard [ZFEN30001 - ] --- ANZ --- APAC --- MEA, T7.210 Standard [ZFEN30001 - ] --- ANZ --- APAC --- MEA	
10005-Front axle position sensor - threshold lower than set limit [UCM] .....	1206
T7.175 AutoCommand™ --- ANZ --- APAC --- MEA, T7.175 Sidewinder II [ZFEN30001 - ] --- ANZ --- APAC --- MEA, T7.190 AutoCommand™ --- ANZ --- APAC --- MEA, T7.190 Sidewinder II [ZFEN30001 - ] --- ANZ --- APAC --- MEA, T7.210 AutoCommand™ --- ANZ --- APAC --- MEA, T7.210 Sidewinder II [ZFEN30001 - ] --- ANZ --- APAC --- MEA, T7.225 AutoCommand™ --- ANZ --- APAC --- MEA	
10008-Go down error - suspension unable to return to set point [ACU] .....	1207
T7.175 Standard [ZFEN30001 - ] --- ANZ --- APAC --- MEA, T7.190 Standard [ZFEN30001 - ] --- ANZ --- APAC --- MEA, T7.210 Standard [ZFEN30001 - ] --- ANZ --- APAC --- MEA	
10008-Go down error - suspension unable to return to set point [UCM] .....	1208
T7.175 AutoCommand™ --- ANZ --- APAC --- MEA, T7.175 Sidewinder II [ZFEN30001 - ] --- ANZ --- APAC --- MEA, T7.190 AutoCommand™ --- ANZ --- APAC --- MEA, T7.190 Sidewinder II [ZFEN30001 - ] --- ANZ --- APAC --- MEA, T7.210 AutoCommand™ --- ANZ --- APAC --- MEA, T7.210 Sidewinder II [ZFEN30001 - ] --- ANZ --- APAC --- MEA, T7.225 AutoCommand™ --- ANZ --- APAC --- MEA	
10009-Lower lockout solenoid error [ACU] .....	1210
T7.175 Standard [ZFEN30001 - ] --- ANZ --- APAC --- MEA, T7.190 Standard [ZFEN30001 - ] --- ANZ --- APAC --- MEA, T7.210 Standard [ZFEN30001 - ] --- ANZ --- APAC --- MEA	
10009-Lower lockout solenoid error [UCM] .....	1211
T7.175 AutoCommand™ --- ANZ --- APAC --- MEA, T7.175 Sidewinder II [ZFEN30001 - ] --- ANZ --- APAC --- MEA, T7.190 AutoCommand™ --- ANZ --- APAC --- MEA, T7.190 Sidewinder II [ZFEN30001 - ] --- ANZ --- APAC --- MEA, T7.210 AutoCommand™ --- ANZ --- APAC --- MEA, T7.210 Sidewinder II [ZFEN30001 - ] --- ANZ --- APAC --- MEA, T7.225 AutoCommand™ --- ANZ --- APAC --- MEA	
10010-Chassis accelerometer - voltage too low (short circuit to ground / open circuit) [ACU] .....	1213
T7.175 Standard [ZFEN30001 - ] --- ANZ --- APAC --- MEA, T7.190 Standard [ZFEN30001 - ] --- ANZ --- APAC --- MEA, T7.210 Standard [ZFEN30001 - ] --- ANZ --- APAC --- MEA	

## 1019-Load sensing pin 8V reference - voltage too low

T7.175 AutoCommand™	ANZ --- APAC --- MEA
T7.175 Sidewinder II [ZFEN30001 - ]	ANZ --- APAC --- MEA
T7.190 AutoCommand™	ANZ --- APAC --- MEA
T7.190 Sidewinder II [ZFEN30001 - ]	ANZ --- APAC --- MEA
T7.210 AutoCommand™	ANZ --- APAC --- MEA
T7.210 Sidewinder II [ZFEN30001 - ]	ANZ --- APAC --- MEA
T7.225 AutoCommand™	ANZ --- APAC --- MEA

### Control Module : UCM

**NOTE:** When the cause of the error code has been rectified, clear the error code and test the system for normal operation.

#### Possible failure modes:

1. Faulty load sensing pin
2. Faulty load sensing pin
3. Faulty wire harness
4. Faulty controller

#### Solution:

1. Check the **8 Volts** sensor supply in H9 channel 216. Refer to **Electronic module Universal controller - H9 - Voltmeter diagnostic (55.640)**.
  - A. If the value displayed is approximately 8500, check for an intermittent circuit to the load sensing pin, repair or replace the wire harness as required. If the error recurs and no intermittent circuit is indicated, download the correct level of software. If the fault recurs, remove and replace the controller.
  - B. If the value displayed is not approximately 8500, continue to Step 2.
2. Check for a short to ground.  
Disconnect the controller connector **X-950** and both load sensing pin connectors **X-256** and **X-266**. Check between connector:
  - X-256 pin 3**, wire 5075A (PK) and ground
  - X-266 pin 3**, wire 5075B (PK) and ground
  - A. If a short to ground is indicated, repair or replace the wire harness as required.
  - B. If a short to ground is not indicated, continue to Step 3.
3. Check for an open circuit.  
Check between connector:
  - X-256 pin 3**, wire 5075A (PK) and **X-950 pin 6**, wire CM-5075 (PK)
  - X-256 pin 1**, wire 60H (BK/WH) and ground
  - X-266 pin 3**, wire 5075B (PK) and **X-950 pin 6**, wire CM-5075 (PK)
  - X-266 pin 1**, wire 60BA (BK/WH) and ground
  - A. If an open circuit is indicated, repair or replace the wire harness as required.
  - B. If the wire harness is okay, continue to Step 4.
4. Replace the load sensing pin(s).  
Remove and replace the load sensing pin(s).
  - A. If the error recurs, refit the old load sensing pins and download the correct level of software. If the fault recurs, remove and replace the controller.

**Wiring harnesses - Electrical schematic sheet 17 – CONTROL UNIT (electronic draft control)**  
**(55.100.DP-C.20.E.17)**

## 2006-No signal from the radar

T7.175 Standard [ZFEN30001 - ]	ANZ --- APAC --- MEA
T7.190 Standard [ZFEN30001 - ]	ANZ --- APAC --- MEA
T7.210 Standard [ZFEN30001 - ]	ANZ --- APAC --- MEA

### Control Module : CCU

**NOTE:** When the cause of the error code has been rectified, clear the error code and test the system for normal operation.

#### Possible failure modes:

1. Incorrectly positioned radar
2. Faulty connector
3. Faulty wire harness
4. Faulty radar

#### Solution:

1. Check the position of the radar.
  - A. If the radar is pointing at the tractor wheel or excessively vibrating, point the radar at the ground and tighten the fixings.
  - B. If the radar mounting and position is okay, continue to Step 2.
2. Check the radar connector **X-233**. Ensure the connector is connected, not damaged, the pins are in the correct position and the fit is tight.
  - A. If a fault is indicated, repair or replace as required.
  - B. If the connector is okay, continue to Step 3.
3. Check for **12 Volts**.  
Turn the ignition switch ON. Measure the voltage between **X-233 pin 3**, wire 1050G (RD) and ground.
  - A. If approximately **12 Volts** is not indicated, repair or replace the wire harness as required.
  - B. If approximately **12 Volts** is indicated, continue to Step 4.
4. Check for an open ground circuit.  
Check between connector **X-233 pin 2**, wire 57JD (BK) and ground.
  - A. If an open ground circuit is indicated, repair or replace the wire harness as required.
  - B. If an open ground circuit is not indicated, continue to Step 5.
5. Check for an open circuit.  
Turn the ignition switch OFF. Disconnect the CCU connector **X-093**. Check between connector: **X-093 pin 19**, wire 2031 (YE) and **X-233 pin 4**, wire 2031 (YE)  
**X-093 pin 33**, wire 2028B (GN) and **X-233 pin 1**, wire 20208B (GN)
  - A. If an open circuit is indicated, repair or replace the wire harness as required.
  - B. If the wire harness is okay, remove and replace the radar assembly.

**Wiring harnesses - Electrical schematic sheet 17 – CONTROL UNIT (electronic draft control)**  
**(55.100.DP-C.20.E.17)**

**Wiring harnesses - Electrical schematic sheet 18 – CONTROL UNIT (5V sensor supply, seat, backup alarm)  
(55.100.DP-C.20.E.18)**

## 2324-Transmission mid speed sensor - short to ground

T7.175 Standard [ZFEN30001 - ]	ANZ Transmission - Powershift transmission --- APAC Transmission - Powershift transmission --- MEA Transmission - Powershift transmission
T7.190 Standard [ZFEN30001 - ]	ANZ Transmission - Powershift transmission --- APAC Transmission - Powershift transmission --- MEA Transmission - Powershift transmission
T7.210 Standard [ZFEN30001 - ]	ANZ Transmission - Powershift transmission --- APAC Transmission - Powershift transmission --- MEA Transmission - Powershift transmission

### Control Module : CCU

**NOTE:** When the cause of the error code has been rectified, clear the error code and test the system for normal operation.

#### Possible failure modes:

1. Faulty connector
2. Faulty transmission mid speed sensor
3. Faulty wire harness

#### Solution:

1. Check the transmission mid speed sensor connector **X-653**, the wire harness connector **X-022** and the Central Control Unit (CCU) connector **X-095**. Ensure the connectors are connected, not damaged, the pins are in the correct position and that the fit is tight.
  - A. If a fault is indicated, repair or replace as required.
  - B. If the connectors are okay, continue to Step 2.
2. Check for + **12 Volts**.  
Disconnect connector **X-653**. Turn the ignition switch ON. Measure the voltage between connector **X-653 pin 1**, wire 7000BS (BL) and ground.
  - A. If + **12 Volts** is not indicated, repair or replace the wire harness as required.
  - B. If + **12 Volts** is indicated, continue to Step 3.
3. Check for an open ground circuit.  
Check between connector **X-653 pin 3**, wire 60BE (BK/WH) and ground.
  - A. If an open circuit is indicated, repair or replace the wire harness as required.
  - B. If an open circuit is not indicated, continue to Step 4.
4. Check for a short to ground.  
Turn the ignition switch OFF. Disconnect connector **X-095**. Check between connector **X-653 pin 2**, wire 7400 (YE) and ground.
  - A. If a short to ground is indicated, repair or replace the wire harness as required.
  - B. If the wire harness is okay, remove and replace the mid speed sensor.

**Wiring harnesses - Electrical schematic sheet 15 – CONTROL UNIT (transmission 1, four-wheel drive and differential lock) (55.100.DP-C.20.E.15)**

## 2351-Creeper solenoid - open circuit or short circuit to ground

T7.175 Standard [ZFEN30001 - ]	ANZ --- APAC --- MEA
T7.190 Standard [ZFEN30001 - ]	ANZ --- APAC --- MEA
T7.210 Standard [ZFEN30001 - ]	ANZ --- APAC --- MEA

### Control Module : CCU

**NOTE:** When the cause of the error code has been rectified, clear the error code and test the system for normal operation.

#### Possible failure modes:

1. Faulty connector
2. Faulty creeper solenoid
3. Faulty wire harness
4. Faulty Central Control Unit (CCU)

#### Solution:

1. Check the creeper solenoid connector **X-631**, the wire harness connectors **X-022** and **X-633** and the CCU connector **X-095**. Ensure the connector is connected, not damaged, the pins are in the correct position and that the fit is tight.
  - A. If a fault is indicated, repair or replace as required.
  - B. If the connector is okay, continue to Step 2.
2. Check the creeper solenoid.  
Disconnect connector **X-631**. Measure the resistance between the solenoid terminals:
  - Terminal 1 and terminal 2
  - Terminal 1 and ground
  - Terminal 2 and ground
  - A. If the resistance indicated is not between **6 - 8 Ohms** or a short to ground is indicated, remove and replace the creeper solenoid.
  - B. If the creeper solenoid is okay, continue to Step 3.
3. Check for an open circuit.  
Disconnect connector **X-095**. Check between connector:
  - X-631** pin 1, wire 7005A (BL) and **X-095** pin 5, wire 7005 (BL)
  - X-631** pin 2, wire 7580A (BL) and **X-095** pin 2, wire 7580 (BL)
  - A. If an open circuit is indicated, repair or replace the wire harness as required.
  - B. If an open circuit is not indicated, continue to Step 4.
4. Check for a short circuit or short to ground.  
Check between connector:
  - X-631** pin 1, wire 7005A (BL) and **X-631** pin 2, wire 7580A (BL)
  - X-631** pin 1, wire 7005A (BL) and ground
  - X-631** pin 2, wire 7580A (BL) and ground
  - A. If a short circuit or short to ground is indicated, repair or replace the wire harness as required.
  - B. If the wire harness is okay, download the correct level of software. If the fault recurs, remove and replace the CCU.

**Wiring harnesses - Electrical schematic sheet 16 – CONTROL UNIT (transmission 2) (55.100.DP-C.20.E.16)**

## 2369-High range clutch not calibrated

T7.175 Sidewinder II [ZFEN30001 - ]	ANZ Transmission - Powershift transmission --- APAC Transmission - Powershift transmission --- MEA Transmission - Powershift transmission
T7.190 Sidewinder II [ZFEN30001 - ]	ANZ Transmission - Powershift transmission --- APAC Transmission - Powershift transmission --- MEA Transmission - Powershift transmission
T7.210 Sidewinder II [ZFEN30001 - ]	ANZ Transmission - Powershift transmission --- APAC Transmission - Powershift transmission --- MEA Transmission - Powershift transmission

### Control Module : UCM

**NOTE:** When the cause of the error code has been rectified, clear the error code and test the system for normal operation.

#### Context:

Poor clutch performance of the uncalibrated clutch.

#### Possible failure modes:

1. Faulty solenoid
2. Faulty hydraulic circuit
3. Mechanical fault

#### Solution:

1. Perform the transmission calibration procedure. Refer to **Electronic module Universal controller - H1 - Calibration procedures (55.640)**.
  - A. If the error code is still displayed, continue to Step 2.
2. Check for other error codes being displayed.
  - A. If any other error code is being displayed, continue to these tests.
  - B. If no other error code is displayed, continue to Step 3.
3. Check the solenoid of the faulty clutch.
  - A. Remove the solenoid, clean or replace as required.
  - B. If the error code is still displayed, check the clutch pack pressures. Refer to **Hydraulic systems - Pressure test (35.000)**.

## 2414-Disable range selected by operator

T7.175 Sidewinder II [ZFEN30001 - ]	ANZ Transmission - Semi-Powershift transmission --- APAC Transmission - Semi-Powershift transmission --- MEA Transmission - Semi-Powershift transmission
T7.190 Sidewinder II [ZFEN30001 - ]	ANZ Transmission - Semi-Powershift transmission --- APAC Transmission - Semi-Powershift transmission --- MEA Transmission - Semi-Powershift transmission
T7.210 Sidewinder II [ZFEN30001 - ]	ANZ Transmission - Semi-Powershift transmission --- APAC Transmission - Semi-Powershift transmission --- MEA Transmission - Semi-Powershift transmission

### Control Module : UCM

**NOTE:** When the cause of the error code has been rectified, clear the error code and test the system for normal operation.

#### Possible failure modes:

1. Faulty range solenoid
2. Faulty wire harness
3. Transmission mechanical or hydraulic fault

#### Solution:

1. Before proceeding clear the error code. Run the machine under normal conditions and retest.
  - A. If the error code is not indicated, check that the system is operating correctly.
  - B. If the error code is indicated, continue to Step 2.
2. Check for other error codes being displayed.
  - A. If any other error code is being displayed, continue to these tests.
  - B. If no other error code is displayed, pressure test the transmission. Refer to **Hydraulic systems - Pressure test (35.000)**.

---

## 2567-Gear pump (hydro filter) - pressure too low

T7.175 AutoCommand™	ANZ --- APAC --- MEA
T7.190 AutoCommand™	ANZ --- APAC --- MEA
T7.210 AutoCommand™	ANZ --- APAC --- MEA
T7.225 AutoCommand™	ANZ --- APAC --- MEA

### Control Module : UCM

**NOTE:** When the cause of the error code has been rectified, clear the error code and test the system for normal operation.

#### Possible failure modes:

1. Faulty hydro filter pressure sensor (charge pressure sensor) **X-523**
2. Faulty hydraulic circuit
3. Mechanical fault

#### Solution:

1. Check for other error codes being displayed.
  - A. If any other error code is being displayed, continue to these tests.
  - B. If no other error code is displayed, pressure test the system to diagnose the cause. For further information, refer to **Hydraulic systems - Pressure test (35.000)**.

- A. If there is continuity to chassis ground, leave connector **X-827** disconnected and continue with Step 5.
- B. If there is no continuity, there is a short to ground condition in the engine harness between the valve cover connector **X-827** pin 3 (WH) and the engine plug connector **X-917** pin 25 (WH). Locate and repair the grounded conductor.

5. Determine location of the short to ground condition.

Remove the injector (valve) cover and disconnect the injector harness from Cylinder 5 injector at Y-065.

Use a multimeter to check for continuity, on the injector:

From	To	Value
Y-065 pin 1	chassis ground	There should be no continuity

- A. If there is continuity, Cylinder 5 injector Y-065 solenoid coil has failed, replace the injector.
- B. If there is no continuity, there is a short to ground condition in Cylinder 5 injector circuit, between Y-065 pin 2 and connector **X-827** pin 3. Locate and repair the grounded conductor.

6. Disconnect the engine cylinder harness from the injector (valve) cover at connector **X-827**.

Use a multimeter to measure the resistance on the injector cover side of the valve cover:

From	To	Value
<b>X-827</b> pin 3	<b>X-827</b> pin 4	There should be greater than <b>0.1 Ω</b>

- A. If the resistance is greater than **0.1 Ω**, there is a short circuit condition in the engine injector harness between the valve cover connector **X-827** and the engine plug connector **X-917**. Locate and repair the short circuit.
- B. If the resistance is less than **0.1 Ω**, continue with step 7.

7. Remove the injector (valve) cover and disconnect the injector harness from Cylinder 5 injector at Y-065.

Use a multimeter to check for continuity, on the injector:

From	To	Value
Y-065 pin 1	Y-065 pin 2	There should be greater than <b>0.1 Ω</b>

- A. If there is greater than **0.1 Ω**, there is a short circuit condition in the injector harness, between connector **X-827** and Y-065 pin 1 and pin 2. Locate and repair the shorted conductors.
- B. If the resistance is less than **0.1 Ω**, the Cylinder 5 injector Y-065 solenoid coil has failed. Replace the injector.

8. Check the ECU A-095 supply voltage.

Disconnect the vehicle interface harness (VE) from the ECU A-095 at the vehicle plug connector **X-911**.

Turn the ignition switch ON.

Use a multimeter to check for voltage on the vehicle interface (VE) harness side of the vehicle plug:

From	To	Value
<b>X-911</b> pin 1, wire 6408B (GN)	chassis ground	There should be <b>12.0 V</b>
<b>X-911</b> pin 25, wire 6408C (GN)	chassis ground	There should be <b>12.0 V</b>
<b>X-911</b> pin 26, wire 6408D (GN)	chassis ground	There should be <b>12.0 V</b>
<b>X-911</b> pin 49, wire 6408E (GN)	chassis ground	There should be <b>12.0 V</b>
<b>X-911</b> pin 73, wire 6408F (GN)	chassis ground	There should be <b>12.0 V</b>

- A. If the **12.0 V** is present for all five checks, leave the vehicle plug connector **X-911** disconnected and continue with Step 9.
- B. If the **12.0 V** is not present for one or more of the checks, use the appropriate vehicle electrical schematics to locate and repair the failure.

9. Check the ECU A-095 ground circuits.

## 3170 (DTC 38CB)-NH3 sensor signal is not changing

### Control Module : ECU

**NOTE:** Because this fault causes inducement, it is necessary to perform the SCR Fault Repair Verification Test once the fault has been resolved. See the corresponding configure menu in the Electronic Service Tool (EST).

**NOTE:** Because this fault causes inducement, it is necessary to perform the Engine Restart Counter Reset / Unlock Inducement configuration with the EST before you return the machine to service. See the corresponding configure menu in the EST.

#### Context:

For information regarding the functional operation of the NH3 sensor and the NH3 control unit A-087 refer to the appropriate manual. The NH3 control unit A-087 is required to report information at regular intervals to the Engine Control Unit (ECU) A-095 via Controller Area Network (CAN). If the NH3 sensor signal is not changing over time or the NH3 control unit A-087 is not reporting change, this fault will occur.

#### Cause:

The NH3 control unit A-087 has reported, via CAN, to the ECU A-095 that the NH3 sensor signal is not changing over time.

#### Possible failure modes:

1. Faulty NH3 sensor, damaged or improperly or not installed
2. Faulty NH3 control unit A-087, hardware or software

#### Solution:

1. Verify condition of NH3 sensor.

Remove and inspect the NH3 sensor for debris accumulation, sensing tip breakage, or other damage.

There should be no accumulation, breakage or damage.

A. If accumulation, breakage or damage is found, replace the NH3 sensor. Then use the EST to perform the Engine Restart Counter Reset / Unlock Inducement configuration. Then perform the SCR Fault Repair Verification Test. Then return the machine to service.

B. If no accumulation, breakage or damage is found, continue with Step 2.

2. As there is no method for field testing or re-flashing the sensor controller, replace the NH3 control unit A-087.

Then use the EST to perform the Engine Restart Counter Reset / Unlock Inducement configuration.

Then perform the SCR Fault Repair Verification Test.

Then check to see if the fault is resolved.

A. If the fault is resolved, return the machine to service.

B. If the fault is not resolved, check the ECU A-095 for the appropriate software and re-flash, if necessary.

## 3263 (DTC 971B)-CAN C Bus off failure

### Control Module : ECU

#### Context:

The Engine Control Unit (ECU) A-095 is capable of connecting to and communicating on three separate Controller Area Networks (CAN). Proper configuration and monitoring of the three twisted pair configured networks is also a function of the ECU A-095. CAN Node C Bus is the main engine interface bus. The ECU A-095 provides a CAN termination resistor for the CAN Node C Bus, internal to the ECU A-095. If the ECU A-095 senses that CAN Node C Bus is not functioning properly, this fault will occur.

#### Cause:

ECU A-095 has sensed a "Bus Off" state to be present at CAN Node C.

#### Possible failure modes:

1. Faulty supply voltage or ground, missing
2. Faulty CAN circuit wiring, open circuit, short to ground, or short circuit
3. Faulty ECU A-095, termination resistor or software

#### Solution:

1. Verify fault is present and in active state.

Use the Electronic Service Tool (EST) to check the status of this fault.

A. If the fault is present and active, continue with Step 2.

B. If the fault is no longer present or is in an inactive state, the fault may be intermittent and not currently active. Continue with Step 6.

2. Check for other vehicle CAN faults.

Use the EST to determine if other engine CAN faults exist.

A. If other engine CAN faults do exist, resolve the engine CAN faults, then check to see that **DTC 971B - CAN C Bus off failure** is also resolved.

B. If other engine CAN faults do not exist, continue with Step 3.

3. Check the ECU A-095 supply voltage.

Disconnect the vehicle (VE) harness from the ECU A-095 at connector **X-911**.

With the ignition switch in the ON position, use a multimeter to check for voltage on the vehicle (VE) harness side:

From	To	Value
<b>X-911 pin 1</b> , wire 6408B (GN)	chassis ground	There should be <b>12.0 V</b>
<b>X-911 pin 25</b> , wire 6408C (GN)	chassis ground	There should be <b>12.0 V</b>
<b>X-911 pin 26</b> , wire 6408D (GN)	chassis ground	There should be <b>12.0 V</b>
<b>X-911 pin 49</b> , wire 6408E (GN)	chassis ground	There should be <b>12.0 V</b>
<b>X-911 pin 73</b> , wire 6408F (GN)	chassis ground	There should be <b>12.0 V</b>

A. If the voltage is present on all of the checks, leave connector **X-911** disconnected and continue with Step 4.

B. If the voltage is not present for one or more of the checks, refer to the appropriate vehicle service manual and electrical schematics to locate and restore supply power to the ECU A-095.

4. Check the ECU A-095 grounding.

With the ignition switch in the OFF position, use a multimeter to check for continuity on the vehicle (VE) harness side:

---

## 3525 (DTC E18E)-Downstream NO<sub>x</sub> sensor internal failure (open circuit error)

### Control Module : ECU

**NOTE:** Because this fault causes inducement, it is necessary to perform the SCR Fault Repair Verification Test once the fault has been resolved. See the corresponding configure menu in the Electronic Service Tool (EST).

**NOTE:** Because this fault causes inducement, it is necessary to perform the Engine Restart Counter Reset / Unlock Inducement configuration with the EST before you return the machine to service. See the corresponding configure menu in the EST.

#### Context:

For information regarding the functional operation of the smart Selective Catalytic Reduction (SCR) downstream NO<sub>x</sub> sensor A-084 see the appropriate manual. The SCR downstream NO<sub>x</sub> sensor A-084 has internal monitoring for open wire or short circuit and sends an error status in case of a detected failure. This failure is the result of an open circuit error in the sensor NO<sub>x</sub> and/or Oxygen level circuit.

#### Cause:

The SCR downstream NO<sub>x</sub> sensor A-084 has reported, via CAN, to the ECU A-095 that an open circuit condition exists in the NO<sub>x</sub> and/or Oxygen level circuit.

#### Possible failure modes:

1. Faulty SCR downstream NO<sub>x</sub> sensor A-084, hardware or firmware
2. Faulty ECU A-095, software

#### Solution:

1. Verify fault is present and active.

Use the Electronic Service Tool (EST) to check the status of this fault.

A. If the fault is present and active, continue with Step 2.

B. If the fault is no longer present or in an inactive state, the fault may be intermittent and not currently active. Continue with Step 3.

2. As there is no method for field testing or re-flashing the sensor controller, replace the SCR downstream NO<sub>x</sub> sensor A-084.

Then use the EST to perform the Replacement of the Nox Downstream Sensor - Reset ECU Data configuration. See the corresponding configure menu in the EST.

Then use the EST to perform the Engine Restart Counter Reset / Unlock Inducement configuration. See the corresponding configure menu in the EST.

Then perform the SCR Fault Verification Test. See the corresponding configure menu in the EST.

Then check to see that this fault is resolved.

A. If this fault is resolved, return the machine to service.

B. If this fault is not resolved, check the ECU A-095 for the appropriate software and re-flash, if necessary.

3. Visually inspect the relevant harnesses and connectors for damage, bent or dislocated pins, corroded terminals, or broken wires. Verify that the connectors are fully installed. Flex the harnesses involved to reveal intermittent breaks or shorts in the wiring concerned. Operate the machine while you monitor the display.

A. If you find damage or the display indicates other than normal display readings, then repair the damage discovered during the inspection or locate and repair the other than normal display condition and verify that the error has been resolved.

## **3758 (DTC E3DD)-Post injection efficiency failure**

### **Control Module : ECU**

#### **Context:**

Engine performance is assisted by the addition of pilot injections, main injections and post injections. The Electronic Control Unit (ECU) A-095 monitors the post injection 3 efficiency. If injection is not commanded at an engine speed greater than **1200 RPM** and an engine speed greater than **1320 RPM** is then detected at least two times, this fault will occur.

#### **Cause:**

The A-095 has detected an unwanted increase in engine speed. This failure may have been caused by unwanted leakage of fuel or engine oil into the engine or by unwanted post injections.

#### **Possible failure modes:**

1. Faulty fuel injectors, leakage
2. Engine oil leakage into cylinders, faulty piston rings
3. Faulty A-095, software

- A. If the value is within the specified range, continue to Step 3.
  - B. If the value is not within the specified range, the after run disconnection relay K-063 has failed internally. Replace the after run disconnection relay K-063.
4. Check the after run disconnection relay K-063 high side circuit for a short to ground condition.

Disconnect connector **X-944**.

The ignition switch must be in the OFF position.

Use a multimeter to perform the following continuity check:

From	To	Value
<b>X-911 pin 22</b> , wire 1934 (WH)	Chassis ground	There should be no continuity.
<b>X-911 pin 22</b> , wire 1934 (WH)	<b>X-911 pin 24</b> , wire 1933 (WH)	There should be no continuity.
<b>X-911 pin 22</b> , wire 1934 (WH)	All other pins	There should be no continuity.

- A. If there is continuity, there is a short to ground condition in the after run disconnection relay K-063 high side circuit. Locate and repair the shorted conductor.
  - B. If there is no continuity, check the ECU A-095 for the appropriate software and re-flash, if necessary.
5. Visually inspect the relevant harnesses and connectors for damage, bent or dislocated pins, corroded terminals, or broken wires. Verify that the connectors are fully installed. Flex the harnesses involved to reveal intermittent breaks or shorts in the wiring concerned. Operate the machine while you monitor the display.
- A. If you find damage or the display indicates other than normal display readings, then repair the damage discovered during the inspection or locate and repair the other than normal display condition and verify that the error has been resolved.
  - B. If you do not find damage and the display indicates only normal readings, then erase the fault code and continue operation.

**Wiring harnesses - Electrical schematic sheet 11 (55.100) Wiring harnesses - Electrical schematic sheet 12 (55.100)**

## 4147-Rear remote no. 4 - over voltage

**NOTE:** When the cause of the error code has been rectified, clear the error code and test the system for normal operation.

**NOTE:** If the machine is not fitted with rear remote valves, using H3, channel 1, check the rear Electro Hydraulic Remote valve (EHR) option is set to disabled.

### Possible failure modes:

1. External power supply connected
2. Faulty charging system
3. Faulty controller software
4. Faulty Electro Hydraulic Remote valve (EHR)

### Solution:

1. Check that the tractor battery power supply has not been connected to an external power supply.
  - A. If an external power supply is connected to the tractor, disconnect and test the system for normal operation.
  - B. If an external power supply is not connected to the tractor, continue to Step 2.
2. Check the battery voltage.

Start the engine and run at **2000 rev/min**. Measure the battery voltage.

  - A. If the voltage indicated is greater than approximately **15 Volts**, continue to test for a fault in the charging system.
  - B. If the voltage indicated is between approximately **9 Volts** and **15 Volts**, download the correct level of software into the controller and configure the EHR. If the fault is still present, remove, replace, and configure the EHR.

## 4522-Front remote no. 2 - float position not reached

**NOTE:** When the cause of the error code has been rectified, clear the error code and test the system for normal operation.

### Possible failure modes:

1. Incorrect hydraulic pressure
2. Faulty controller software
3. Faulty Electro Hydraulic Remote valve (EHR)

### Solution:

1. Check for other EHR error code(s).
  - A. Make a note of the error code(s), clear the error code(s) and test the system for normal operation.
  - B. If the fault is still present, continue to Step 2.
2. Check the hydraulic pressures, refer to **Hydraulic systems - Pressure test (35.000)**.
  - A. If the pressures are incorrect, repair or replace component(s) as required.
  - B. If the pressures are okay, download the correct level of software into the controller and configure the EHR. If the fault is still present, remove, replace, and configure the EHR.

## 5012-PTO shift - sensor error

T7.175 AutoCommand™	ANZ --- APAC --- MEA
T7.175 Sidewinder II [ZFEN30001 - ]	ANZ --- APAC --- MEA
T7.190 AutoCommand™	ANZ --- APAC --- MEA
T7.190 Sidewinder II [ZFEN30001 - ]	ANZ --- APAC --- MEA
T7.210 AutoCommand™	ANZ --- APAC --- MEA
T7.210 Sidewinder II [ZFEN30001 - ]	ANZ --- APAC --- MEA
T7.225 AutoCommand™	ANZ --- APAC --- MEA

### Control Module : UCM

**NOTE:** When the cause of the error code has been rectified, clear the error code and test the system for normal operation.

#### Cause:

Due to the interaction between the Power Take-Off (PTO) shift motor and PTO shift sensor, a fault in either of these components may generate this error code.

#### Possible failure modes:

1. Faulty connector
2. Faulty wire harness
3. Faulty PTO shift relay
4. Incorrectly adjusted PTO shift cable
5. Mechanical fault with PTO shift cable
6. Faulty PTO shift motor
7. Faulty PTO shift position sensor
8. Faulty controller

#### Solution:

1. Check the PTO shift motor connector **X-775**, the ESPTO drive upper speed relay connector **X-782**, the ESPTO drive lower speed relay **X-783**, the wire harness connector **X-748** and the controller connectors **X-951**, **X-953** and **X-956**. Ensure the connectors are connected, not damaged, the pins are in the correct position and that the fit is tight.
  - A. If a fault is indicated, repair or replace as required.
  - B. If the connectors are okay, continue to Step 2.
2. Check the operation of the drive relays.  
Operate the PTO shift selector in all speeds and check if the ESPTO drive relays upper speed and lower speed are clicking on and off.
  - A. If the relays are clicking, continue to Step 7.
  - B. If the relays are not clicking on and off, continue to Step 3.
3. Check the PTO drive relays upper speed and lower speed.  
Remove the relays and check the operation of the relays.
  - A. If the relays do not operate correctly, replace the faulty PTO drive relay.
  - B. If the relays are okay, continue to Step 4.
4. Check for **12 Volts**.  
Disconnect the ESPTO drive upper speed relay **X-782** and the ESPTO drive lower speed relay **X-783**. Turn the ignition switch ON. Measure the voltage between connectors:
  - X-782 pin 85**, wire 2050BA (GN) and ground
  - X-782 pin 87A**, wire 2155A (BR) and ground
  - X-783 pin 85**, wire 2050BB (GN) and ground

- A. If an open circuit is indicated, repair or replace the wire harness as required.
- B. If an open circuit is not indicated, continue to Step 5.
5. Check for a short to ground.  
Check between connector:  
**X-957 pin 15**, wire 2248 (PK) and ground  
**X-957 pin 16**, wire 2245 (PK) and ground
- A. If a short to ground is indicated, repair or replace the wire harness as required.
- B. If a short to ground is not indicated, continue to Step 6.
6. Check for a short to positive voltage.  
Measure the voltage between connector:  
**X-957 pin 15**, wire 2248 (PK) and ground  
**X-957 pin 16**, wire 2245 (PK) and ground
- A. If a voltage is indicated, repair or replace the wire harness as required.
- B. If a voltage is not indicated, continue to Step 7.
7. Check for a short circuit.  
Check between connector **X-957 pin 15**, wire 2248 (PK) and **X-957 pin 16**, wire 2245 (PK).
- A. If a short circuit is indicated, repair or replace the wire harness as required.
- B. If the wire harness is okay, remove and replace the front PTO switch. If the fault recurs, continue to Step 8.
8. Check the armrest controller circuit board for a short circuit.  
NOTE: The PTO switch signal is routed directly through the armrest controller and processed by the controller **X-957**.  
Disconnect the armrest controller connector **X-776**. Check between the component side of connector **X-776 pin 7**, wire 2248 (PK) and **X-776 pin 8**, wire 2245 (PK).
- A. If a short circuit is indicated, remove and replace the armrest controller.
- B. If a short circuit is not indicated, continue Step 9.
9. Check the armrest controller circuit board for an open circuit.  
NOTE: The PTO switch signal is routed directly through the armrest controller and processed by the controller **X-957**.  
Make sure connector H11 ( **X-841**) is connected to the armrest controller. While operating the front PTO switch, check between the component side of connector:  
**X-776 pin 4**, wire 2250S (PK) and **X-776 pin 7**, wire 2248 (PK) - an open circuit should be indicated with the switch in one position and a closed circuit indicated in the other position  
**X-776 pin 4**, wire 2250S (PK) and **X-776 pin 8**, wire 2245 (PK) - an open circuit should be indicated with the switch in one position and a closed circuit indicated in the other position
- A. If the results are not as indicated, remove and replace the armrest controller.
- B. If the armrest controller is okay, download the correct level of software into the controller. If the fault recurs, remove and replace the controller.

**Wiring harnesses - Electrical schematic sheet 21 – CONTROL UNIT (front hitch & front power take-off) (55.100.DP-C.20.E.21)**

**Wiring harnesses - Electrical schematic sheet 25 – ARMREST CONTROL UNIT 1 (55.100.DP-C.20.E.25)**

**Wiring harnesses - Electrical schematic sheet 26 – ARMREST CONTROL UNIT 2 (55.100.DP-C.20.E.26)**

B. If the battery voltage is okay, remove and replace the EPL assembly. Refer to **Electronic park lock actuator/controller - Remove (55.031)** and **Electronic park lock actuator/controller - Install (55.031)**. Calibrate the EPL, refer to **Electronic park lock actuator/controller - H1 - Calibration procedures (55.031)**.  
**Wiring harnesses - Electrical schematic sheet 46 – ELECTRONIC PARKING BRAKE (55.100.DP-C.20.E.46)**

---

## 12192-Fault on shuttle lever park switch line

### Control Module : EPL

**NOTE:** When the cause of the error code has been rectified, clear the error code and test the system for normal operation.

**NOTE:** To electronically release and disable the Electronic Park Lock (EPL) when carrying out maintenance on the system, use the H1 calibrations menu in the XA module. Select **(SC)** and perform the accelerometer stroke calibration procedure but stop the process when **(M)** is displayed and turn the ignition switch OFF. For further information, refer to **Electronic park lock actuator/controller - H1 - Calibration procedures (55.031)**.

If electronic release is not possible, remove the EPL cover and use the special tool supplied in the cab to manually disengage the EPL.

**NOTE:** When clearing the stored memory in H8 in the XA module or installing a new EPL, make sure the correct EPL orientation is selected in H3 in the XA module, channel 3. Refer to **Electronic park lock actuator/controller - H3 - Configurations and options (55.031)**.

#### Cause:

The fault triggering condition is 'always'.

#### Possible failure modes:

1. Faulty connector
2. Faulty wire harness
3. Faulty shuttle lever
4. Faulty Electronic Park Lock (EPL) assembly

#### Solution:

1. Make sure the machine is parked on a level surface and chock the front wheels using suitable wheel stops.
  - A. Continue to Step 2.
2. Check for other error codes being displayed.
  - A. If any other error code is being displayed, continue to these tests.
  - B. If no other error code is displayed, continue to Step 3.
3. Before proceeding clear the error code using either the on board HH menu or approved diagnostic equipment. Turn the ignition switch OFF, wait for 5 seconds and then turn the ignition switch ON. Operate the system and check for the error code.
  - A. If the error code is not indicated, check that the system is operating correctly.
  - B. If the error code is indicated, continue to Step 4.
4. Check the EPL connector **X-745** and the shuttle lever connector **X-012**. Ensure the connectors are connected, not damaged, the pins are in the correct position and that the fit is tight.
  - A. If a fault is indicated, repair or replace as required.
  - B. If the connectors are okay, continue to Step 5.
5. Check the shuttle lever park switch in H5 in the XA controller, refer to **Electronic park lock actuator/controller - H5 - Switch operation test (55.031)**. Turn the ignition switch ON. Move the shuttle lever into park.
  - A. If the display does not change to d28, continue to Step 6.
  - B. If the display does change to d28, while still in H5 wiggle the wire harness and the connectors to check for an intermittent circuit. The display will change if an intermittent circuit is detected, repair or replace as required.

## 14100-Air brake pressure - not configured

### Control Module : ICU

**NOTE:** When the cause of the error code has been rectified, clear the error code and test the system for normal operation.

#### Possible failure modes:

1. Air brake option has not been set

#### Solution:

1. Check the air brake option has been set.  
Using the H3 options menu, set the air brake option to 'Yes' on the Instrument Control Unit (ICU). Refer to **Electronic module Instrument control unit - H3 - Configurations and options (55.640)**.

## 18001-Hand throttle #1 - voltage too low

T7.175 AutoCommand™	ANZ --- APAC --- MEA
T7.175 Sidewinder II [ZFEN30001 - ]	ANZ --- APAC --- MEA
T7.190 AutoCommand™	ANZ --- APAC --- MEA
T7.190 Sidewinder II [ZFEN30001 - ]	ANZ --- APAC --- MEA
T7.210 AutoCommand™	ANZ --- APAC --- MEA
T7.210 Sidewinder II [ZFEN30001 - ]	ANZ --- APAC --- MEA
T7.225 AutoCommand™	ANZ --- APAC --- MEA

### Control Module : ACM

**NOTE:** When the cause of the error code has been rectified, clear the error code and test the system for normal operation.

#### Possible failure modes:

1. Faulty hand throttle assembly
2. Incorrect armrest configuration
3. Faulty connector
4. Swapped connectors
5. Faulty armrest controller

#### Solution:

1. Before proceeding clear the error code with the approved diagnostic equipment. Run the machine under normal conditions and retest.
  - A. If the error code is not indicated, check that the system is operating correctly.
  - B. If the error code is indicated, continue to Step 2.
2. Check the armrest controller connectors. Detach the hitch electronic control panel to access the armrest controller. Check the hand throttle connector H6 ( **X-852**) is connected to the correct connector on the armrest controller, not damaged, the pins are in the correct position and that the fit is tight.

A. If several armrest related error codes (18000) are also displayed, download the correct level of software. If the fault recurs, remove and replace the armrest controller. Using the approved diagnostic equipment, configure the armrest controller.

B. If other armrest related error codes are not displayed, remove and replace the hitch electronic control panel assembly. If the fault is still present, download the correct level of software. If the fault recurs, remove and replace the armrest controller. Using the approved diagnostic equipment, configure the armrest controller.

**Wiring harnesses - Electrical schematic sheet 25 – ARMREST CONTROL UNIT 1 (55.100.DP-C.20.E.25)**

**Wiring harnesses - Electrical schematic sheet 26 – ARMREST CONTROL UNIT 2 (55.100.DP-C.20.E.26)**

## 18047-EHR 4 lever position - voltage too low

T7.175 AutoCommand™	ANZ --- APAC --- MEA
T7.175 Sidewinder II [ZFEN30001 - ]	ANZ --- APAC --- MEA
T7.190 AutoCommand™	ANZ --- APAC --- MEA
T7.190 Sidewinder II [ZFEN30001 - ]	ANZ --- APAC --- MEA
T7.210 AutoCommand™	ANZ --- APAC --- MEA
T7.210 Sidewinder II [ZFEN30001 - ]	ANZ --- APAC --- MEA
T7.225 AutoCommand™	ANZ --- APAC --- MEA

### Control Module : ACM

**NOTE:** When the cause of the error code has been rectified, clear the error code and test the system for normal operation.

#### Possible failure modes:

1. Faulty remote control valve lever
2. Incorrect armrest configuration
3. Faulty connector
4. Swapped connectors
5. Faulty armrest controller

#### Solution:

1. Before proceeding clear the error code with the approved diagnostic equipment. Run the machine under normal conditions and retest.
  - A. If the error code is not indicated, check that the system is operating correctly.
  - B. If the error code is indicated, continue to Step 2.
2. Check the armrest controller connectors. Detach the hitch electronic control panel to access the armrest controller. Check the remote control valve 3 and 4 connector H9 ( **X-855** ) is connected to the correct connector on the armrest controller, not damaged, the pins are in the correct position and that the fit is tight.

## 19008 (DTC E7DE)-DiaNH3 sensor open or short in measuring cell circuit

### Control Module : ECU

#### Context:

For information regarding the functional operation of the NH3 sensor B-077 and the NH3 Control Unit A-087 refer to the appropriate manual. The NH3 Control Unit A-087 is required to report information at regular intervals to the Engine Control Unit (ECU) A-095 via Controller Area Network (CAN). If no current is sensed on the signal ground line, this fault will occur.

#### Cause:

The NH3 Control Unit A-087 has reported a short to ground or open circuit error via CAN to the ECU A-095.

#### Possible failure modes:

1. Faulty NH3 sensor B-077 to NH3 Control Unit A-087 wiring, signal ground line is open or grounded
2. Faulty NH3 sensor B-077, open or shorted or grounded internally
3. Faulty NH3 Control Unit A-087, hardware or firmware
4. Faulty ECU A-095, software

#### Solution:

1. Verify fault is present and active.

Use the Electronic Service Tool (EST) to check the status of this fault.

A. If the fault is present and active, continue with Step 2.

B. If the fault is no longer present or in an inactive state, the fault may be intermittent and not currently active. Continue with Step 5.

2. Check for short to ground circuit condition in the NH3 Control Unit A-087 to NH3 sensor B-077 harness (cable).

Disconnect the NH3 Control Unit to NH3 sensor harness (cable) from the NH3 Control Unit A-087.

Use a multimeter to check for continuity on the NH3 Control Unit A-087 to NH3 sensor B-077 harness (cable) side:

From	To	Value
A-087 PIN 7	All other pins.	There should be no continuity.
<b>NOTE:</b> Connector A-087 PIN 7 is also a ground circuit.		

A. If there is continuity on any of the checks, the harness or sensing head is damaged. Replace the NH3 sensor B-077 and its connecting cable.

B. If there is no continuity, leave the connector disconnected and continue with Step 3.

3. As there is no method for field testing the temperature sensing portion of the sensor, replace the NH3 sensor B-077.

Then check to see that this fault is resolved.

A. If the fault is resolved, return the machine to service.

B. If the fault is not resolved, continue with Step 4.

4. As there is no method of field testing or re-flashing the NH3 Control Unit A-087, replace the controller.

Then check to see that this fault is resolved.

A. If the fault is resolved, return the machine to service.

## 19059 (DTC 258E)-Upstream NO<sub>x</sub> sensor internal failure (short circuit error)

### Control Module : ECU

**NOTE:** Because this fault causes inducement, it is necessary to perform the SCR Fault Repair Verification Test once the fault has been resolved. See the corresponding configure menu in the Electronic Service Tool (EST).

**NOTE:** Because this fault causes inducement, it is necessary to perform the Engine Restart Counter Reset / Unlock Inducement configuration with the EST before you return the machine to service. See the corresponding configure menu in the EST.

### Context:

For information regarding the functional operation of the smart Diesel Oxidation Catalyst (DOC) upstream NO<sub>x</sub> sensor A-085 refer to the appropriate manual. The DOC upstream NO<sub>x</sub> sensor A-085 has internal monitoring for open wire or short circuit and sends an error status in case of a detected failure. This failure is the result of a short circuit error in the sensor NO<sub>x</sub> and/or Oxygen level circuit.

### Cause:

The DOC upstream NO<sub>x</sub> sensor A-085 has reported, via CAN, to the ECU A-095 that a short circuit condition exists in the NO<sub>x</sub> and/or Oxygen level circuit.

### Possible failure modes:

1. Faulty DOC upstream NO<sub>x</sub> sensor A-085, hardware or firmware
2. Faulty ECU A-095, software

### Solution:

1. Verify fault is present and active.

Use the Electronic Service Tool (EST) to check the status of this fault.

A. If the fault is present and active, continue with Step 2.

B. If the fault is no longer present or in an inactive state, the fault may be intermittent and not currently active. Continue with Step 3.

2. As there is no method for field testing or re-flashing the sensor controller, replace the DOC upstream NO<sub>x</sub> sensor A-085.

Then use the EST to perform the Replacement of Nox Upstream Sensor - Reset ECU Data configuration. See the corresponding configure menu in the EST.

Then use the EST to perform the Engine Restart Counter Reset / Unlock Inducement configuration. See the corresponding configure menu in the EST.

Then perform the SCR Fault Verification Test. See the corresponding configure menu in the EST.

Then check to see that this fault is resolved.

A. If this fault is resolved, return the machine to service.

B. If this fault is not resolved, check the ECU A-095 for the appropriate software and re-flash, if necessary.

3. Visually inspect the relevant harnesses and connectors for damage, bent or dislocated pins, corroded terminals, or broken wires. Verify that the connectors are fully installed. Flex the harnesses involved to reveal intermittent breaks or shorts in the wiring concerned. Operate the machine while you monitor the display.

A. If you find damage or the display indicates other than normal display readings, then repair the damage discovered during the inspection or locate and repair the other than normal display condition and verify that the error has been resolved.

Use EST to determine if other ATS CAN faults exist.

- A. If other faults do exist, check the supply power, ground and CAN, to locate and repair the faulted condition.
- B. If no other faults exist, the vehicle (VE) harness wiring is damaged between the ATS devices harness splice and the DEF/AdBlue® quality sensor B-076 controller connector **X-889 pin 3**, wire 527FC (BR) and/or **X-889 pin 6**, wire 057SM (BK) for supply power and ground or **X-889 pin 5**, wire 590BZ (BL) and/or **X-889 pin 4**, wire 591BZ (WH) for CAN signal. Locate and repair the damage to the ATS supply power and ground or CAN circuit wiring.

- 5. As there is no method for field testing or re-flashing the sensor controller, replace the DEF/AdBlue® quality sensor B-076 unit.

Then check to see that the fault is resolved.

- A. If the fault is resolved, use the EST to perform the Engine Restart Counter Reset / Unlock Inducement configuration. See the corresponding configure menu in the EST. Then return the machine to service.

- B. If the fault is not resolved, check the ECU A-095 for the appropriate software and re-flash, if necessary.

- 6. Visually inspect the relevant harnesses and connectors for damage, bent or dislocated pins, corroded terminals, or broken wires. Verify that the connectors are fully installed. Flex the harnesses involved to reveal intermittent breaks or shorts in the wiring concerned. Operate the machine while you monitor the display.

- A. If you find damage or the display indicates other than normal display readings, then repair the damage discovered during the inspection or locate and repair the other than normal display condition and verify that the error has been resolved.

- B. If you do not find damage and the display indicates only normal readings, then erase the fault code and continue operation.

**Wiring harnesses - Electrical schematic sheet 14 (55.100) Wiring harnesses - Electrical schematic sheet 56 (55.100)**

B. If there is no continuity, leave both connectors disconnected and continue to Step 4.

4. Check the DEF/Adblue® supply pump A-088 wiring for short to ignition battery power condition.

The ignition switch must be in the ON position.

Use a multimeter to perform the following voltage check:

From	To	Value
X-911 pin 84, wire 9307 (YE)	Chassis ground	There should be no voltage.

A. If there is voltage, there is a short to ignition battery power in the DEF/Adblue® supply pump A-088 circuit. Locate and repair the shorted conductor.

B. If there is no voltage, continue to Step 5.

5. Test the DEF/AdBlue® system.

Use the EST to perform the Urea Dosing System Test (UDST) and follow the on screen instructions.

Use the UDST Trouble Shooting Guideline, as required, to identify and resolve the problem.

Then use the EST to perform the Engine Restart Counter Reset / Unlock Inducement configuration. See the corresponding configure menu in the EST.

Then perform the SCR Fault Verification Test, See the corresponding configure menu in the EST.

Then check to see that this fault is resolved.

A. If the fault is resolved, return the machine to service.

B. If the fault is not resolved, check the ECU A-095 for the appropriate software and re-flash, if necessary.

6. Visually inspect the relevant harnesses and connectors for damage, bent or dislocated pins, corroded terminals, or broken wires. Verify that the connectors are fully installed. Flex the harnesses involved to reveal intermittent breaks or shorts in the wiring concerned. Operate the machine while you monitor the display.

A. If you find damage or the display indicates other than normal display readings, then repair the damage discovered during the inspection or locate and repair the other than normal display condition and verify that the error has been resolved.

B. If you do not find damage and the display indicates only normal readings, then erase the fault code and continue operation.

**Wiring harnesses - Electrical schematic sheet 14 (55.100)**

CLICK HERE TO **DOWNLOAD** THE COMPLETE MANUAL

- Thank you very much for reading the preview of the manual.
- You can download the complete manual from: [www.heydownloads.com](http://www.heydownloads.com) by clicking the link below



- Please note: If there is no response to CLICKING the link, please download this PDF first and then click on it.

CLICK HERE TO **DOWNLOAD** THE COMPLETE MANUAL