

SERVICE MANUAL

T6010 / T6020 / T6030 / T6040 /

T6050 / T6060 / T6070

Tractor

Part number 84276574ANA

1st Edition English
December 2010



CLICK HERE TO **DOWNLOAD** THE COMPLETE MANUAL

- Thank you very much for reading the preview of the manual.
- You can download the complete manual from: www.heydownloads.com by clicking the link below



- Please note: If there is no response to CLICKING the link, please download this PDF first and then click on it.

CLICK HERE TO **DOWNLOAD** THE COMPLETE MANUAL

Coolants

To reduce the amount of deposits and corrosion, the water used in the cooling system must comply with the following values.

Total Hardness	Chloride	Sulphate
300 parts per million	100 parts per million	100 parts per million

Using Plain water

If you reside in a country where antifreeze is not available, use clean water premixed with 5% chemical inhibitor.



Inhibitor solution is irritating to eyes and skin . It contains buffered potassium hydroxide.

B084

- Avoid contact with eyes or prolonged or repeated skin contact.
- Wear protective eyewear when using.
- In case of contact with eyes, flush with water for 15 minutes and obtain medical attention.
- Wash skin with soap and water after use.
- Keep out of reach of children.

Lubrications and Coolant Specifications

RECOMMENDED FLUIDS AND APPLICATIONS	NH SPECIFICATION	INTERNATIONAL SPECIFICATION
ENGINE OIL AMBRA MASTERGOLD HSP 15W-40 AMBRA MASTERGOLD HSP 10W-30	NH 330 H NH 324 H	API CI-4/CH-4, ACEA E7/E5
TRANSMISSION, REAR AXLE AND HYDRAULIC SYSTEM OIL AMBRA MULTI G	NH 410 B	SAE 10W-30 API GL4, ISO VG32/46
FRONT AXLE (Axle and Hubs) AMBRA MULTI G		
FRONT P.T.O GEARBOX OIL AMBRA MULTI G		
ENGINE RADIATOR COOLANT AMBRA AGRIFLU (mixed with 50% of water)	NH 900 A	Ethylene Glycol
BRAKE OIL AMBRA BRAKE LHM	NH 610 A	ISO 7308
AIR CONDITIONING COMPRESSOR OIL Low Viscosity Oil SP10	n/a	PAG-E13, ISO100 Viscosity
GREASE FITTINGS AND BEARINGS AMBRA GR9	NH 710 A	NLGI 2

Regarding filling quantity - see **Capacities ()**

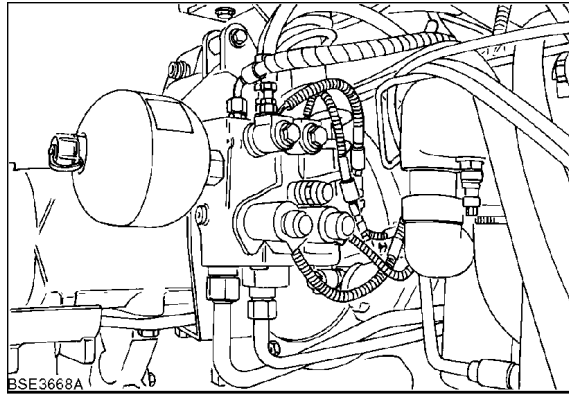

BSE3668A 27

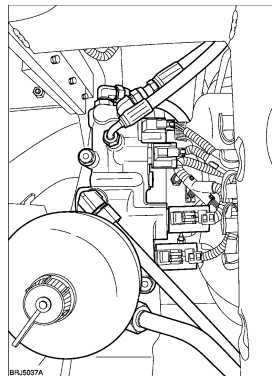

BAIL07APH357HSA 28

Front axle to front support hydraulic control cylinder (1).

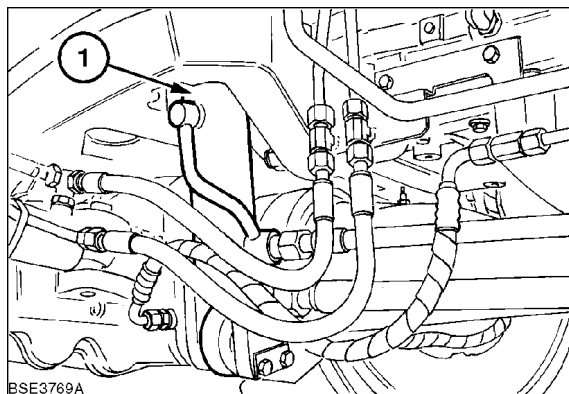

BSE3769A 29

Hydraulic system filters.

Figure 30 shows the main hydraulic filter (1) for tractors fitted with 12 x 12 Transmission with mechanical draft control.

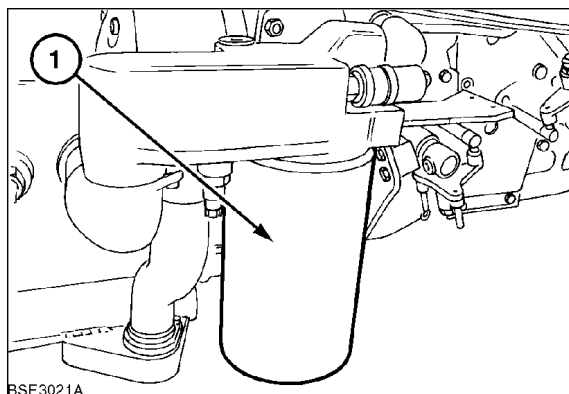

BSE3021A 30

Figure 31 shows the main hydraulic filters for tractors with fixed displacement hydraulic pump. this type of pump is only fitted to tractors with 24 x 24 with mechanical draft control.

Hydraulic pump Fixed displacement pump - Overview

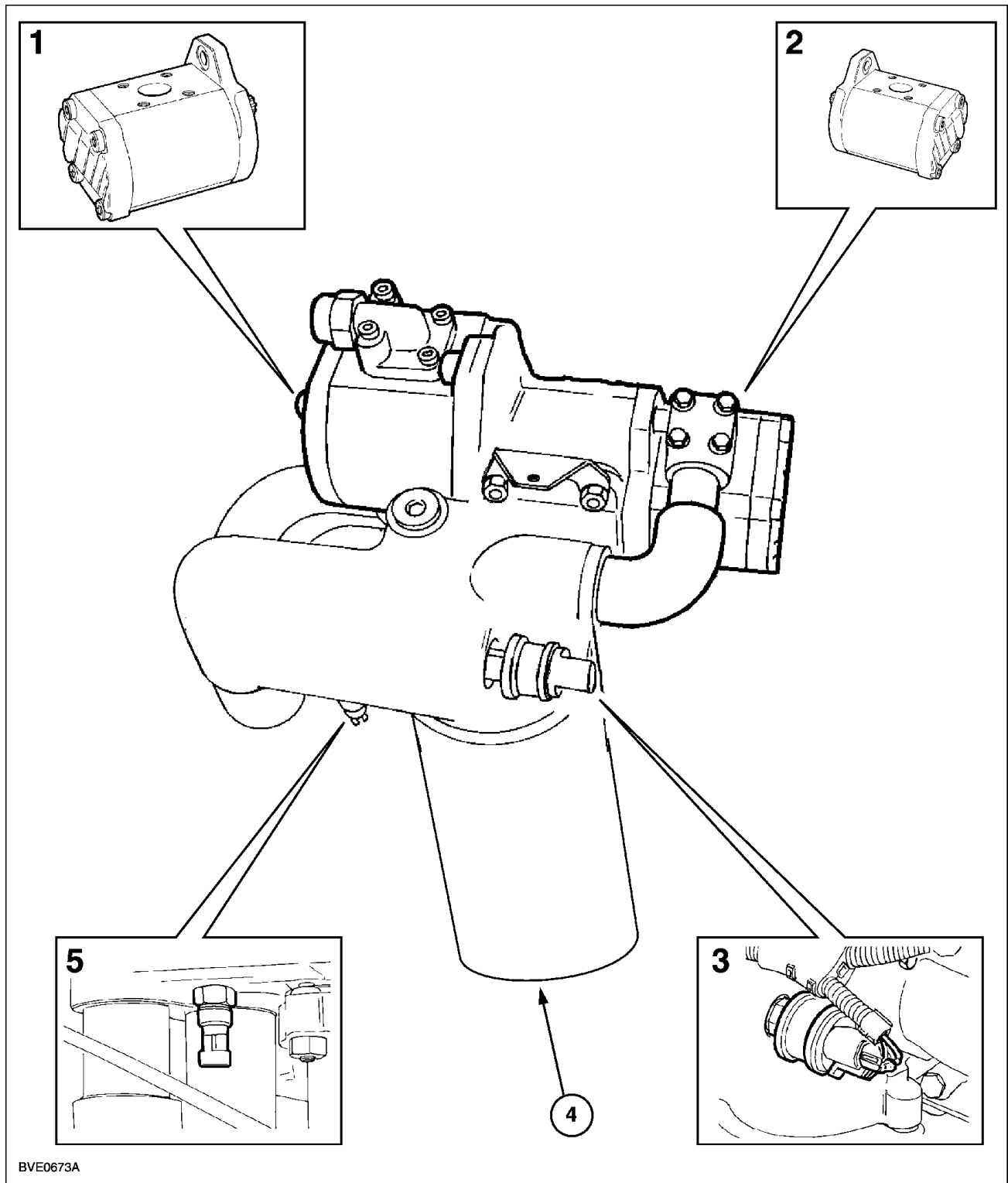

BVE0673A

BVE0673A 1

Hydraulic Pump Assembly With Fixed Displacement Closed Centre System

- 1 Hydraulic lift system oil pump
- 3 Main intake filter restriction (vacuum) switch
- 5 Low oil temperature switch

- 2 Steering / low pressure oil pump
- 4 Main intake filter

Hydraulic pump Variable displacement pump - Overhaul

Hydraulic pump Variable displacement pump - Exploded view (A.10.A)

Prior operation:

Hydraulic pump Variable displacement pump - Remove (A.10.A)

1. Remove pressure and flow compensating valves assembly.

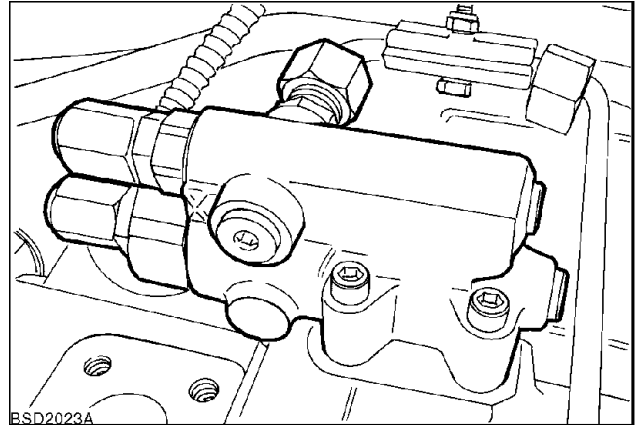

BSD2023A 1

2. Undo the 4 retaining bolts and remove circlip from opposite end of pump. Gently remove charge Pump from main pump assembly.

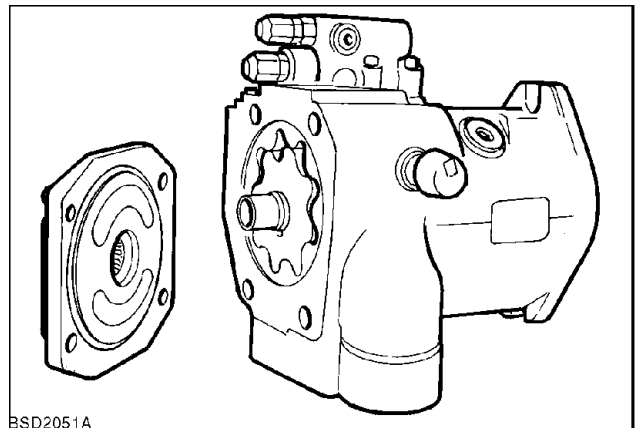

BSD2051A 2

3. Examine valve plate (1). Check to see if it is scored, nicked, warped or damaged by cavitation. Look for score marks or damage around the bearing surface area. Check the inlet and discharge port area for signs of contamination. This contamination may show as grooves starting in the feathering notch.

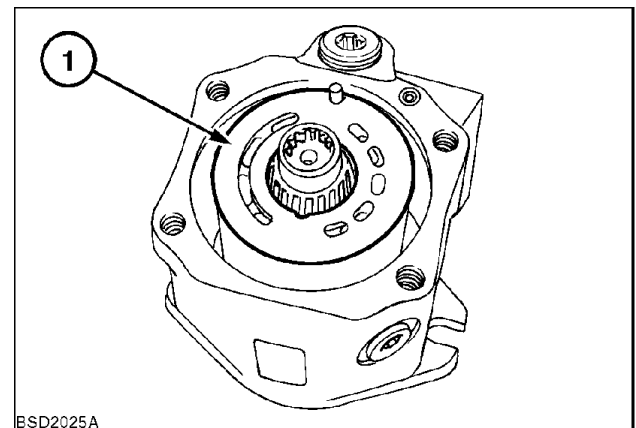

BSD2025A 3

OIL FLOW IN RAISING (CYLINDER EXTEND) Refer to Figure 2

When the remote control valve lever is moved to the raise position, the main control spool **(10)** moves to the right and the spring loaded detent balls **(5)** engage with the left hand groove in the detent mechanism.

Moving the main control spool **(10)** to the raise position causes the pin **(9)** on the lock valve **(8)** to ride up the ramp of the main control spool and hold the lock valve in the open position.

Gallery **(B)** is now open to gallery **(C)** and gallery **(E)** is open to gallery **(F)** .

The flow from gallery **(C)** is blocked by the load hold check valve **(11)** until the pressure in the gallery is sufficient to lift load hold check valve **(11)** off its seat against the back pressure in the lift port gallery **(E)** .

Oil can flow from :-

Gallery **(C)** past the load hold check valve **(11)** into Gallery **(E)** .

Across the flat on the main control spool **(10)** to Gallery **(F)** .

Through the lock valve **(8)**.

Out through the raise port **(7)** of the remote control valve.

Exhaust oil from the extending cylinder returns through the lowering port **(6)** and gallery **(H)**, around the land on the main control spool **(10)** and back to the reservoir via the common gallery **(G)** .

If the load hold check valve **(11)** was not installed the situation could occur where pump pressure is insufficient to support the load in the raise port **(7)** when the remote control valve is moved from neutral to the raise position. Under this situation the load would momentarily drop until pump pressure was sufficient to support the load.

The rate of flow through the remote control valve is adjusted by the manual flow control adjuster **(3)**, which manually changes the size of restriction **(4)**.

To maintain set flow through the remotes under all conditions with varying pump inlet pressure in parallel gallery **(A)** the flow control spool senses the differential pressure across the manually adjusted flow control restriction **(4)** between galleries **(A)** and **(B)** .

The differential pressure sensed on each end of the spool causes the spool to move to a new state of equilibrium and continually regulates the flow across the spool metering lands **(2)** to maintain a constant flow through the manually adjusted flow control restriction **(4)** irrespective of the pressure in other hydraulic circuits.

The pressure in gallery **(C)** is also transmitted down the load sensing gallery **(D)** to the flow compensating valve of the variable flow piston pump where pump output is regulated according to the circuit demand.

Spool Centring and Detent Mechanism

The spool centring and detent mechanism spring loads the main control spool to the neutral position. When the main control spool is moved to the Raise, Lower or Float positions the spool centring and detent mechanism holds the main control spool in position using ball bearings which engage in grooves within a detent cage.

A factory set detent regulating valve in the spool centring and detent mechanism automatically releases the balls and returns the main control spool to neutral whenever the operating pressure exceeds the preset value.

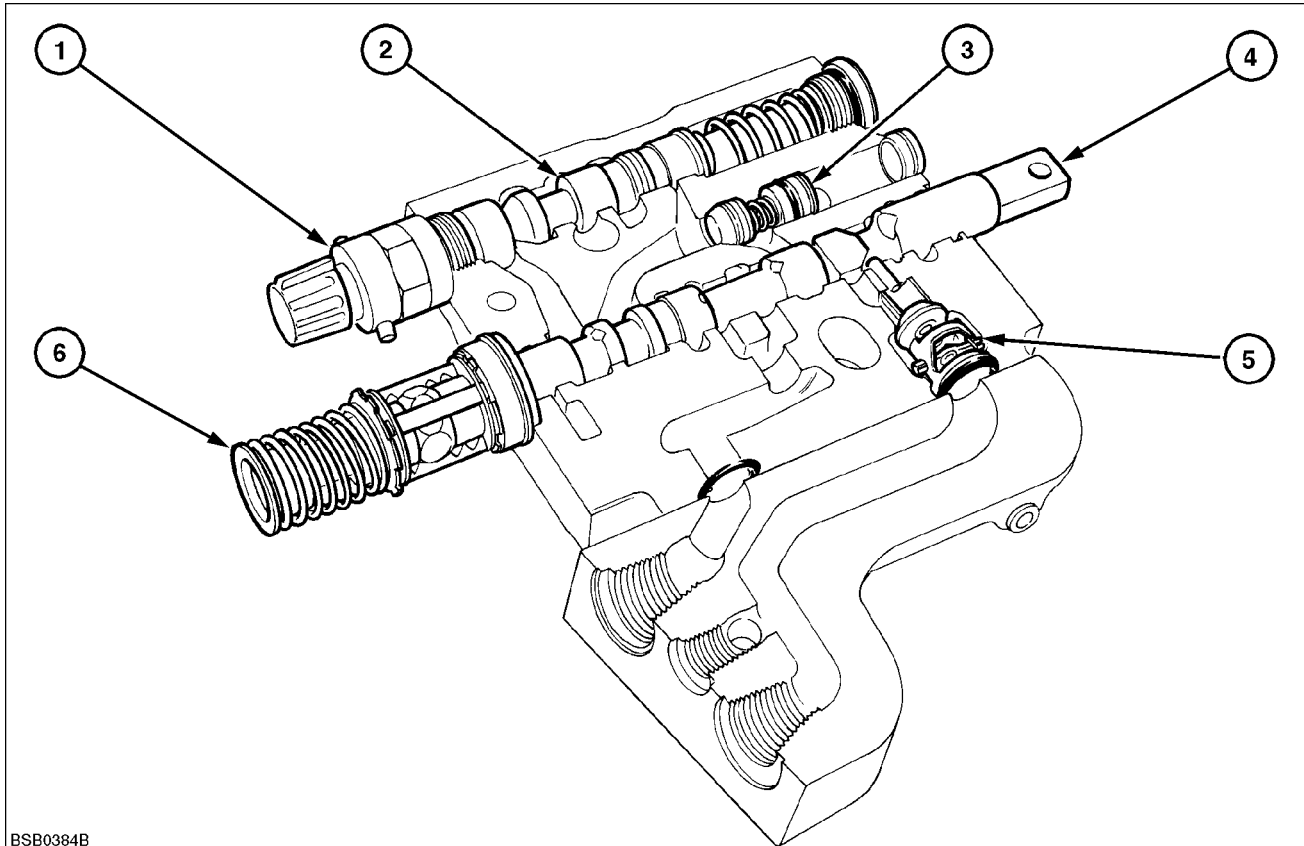

BSB0384B

BAIL06CCM165FSA 10

Remote Control Valve Components

- 1 Flow Control Adjuster
- 3 Load Hold Check Valve
- 5 Lock Valve

- 2 Flow Control Spool
- 4 Main Control Spool
- 6 Spool Centring and Detent Mechanism

Mid-mount remote control valve - Overhaul

1. Clean the machine thoroughly paying particular attention to the hydraulic valve area.
2. Operate lever to relieve hydraulic pressure in the circuits.
3. Remove the operating linkage from the valve spools to be resealed.
4. Remove the two screws and the seal plate from the spool. (Items **(8)** and **(7)** Figure 1).
5. Remove the centring spring housing from the lower end of the valve spool by removing the two screws. (Items **(16)** and **(17)** Figure 1).
6. Remove the screw retaining the centring spring to the spool (Item **(15)** Figure 1). The spool can be prevented from turning by inserting a steel rod in the linkage hole on the upper end.
7. Remove the seal plate from the spool (Item **(1)** Figure 1).
8. Remove the lip seal and wiper ring from either end of the spool (Items **(5)**, **(6)**, **(10)** and **(11)** Figure 1). It may be helpful to slide the spool to push the seals out. Care should be taken not to damage the spool or valve block during this operation. Be aware that the spool will be unsupported at this point and may slide out of the valve block. Support the spool as necessary.

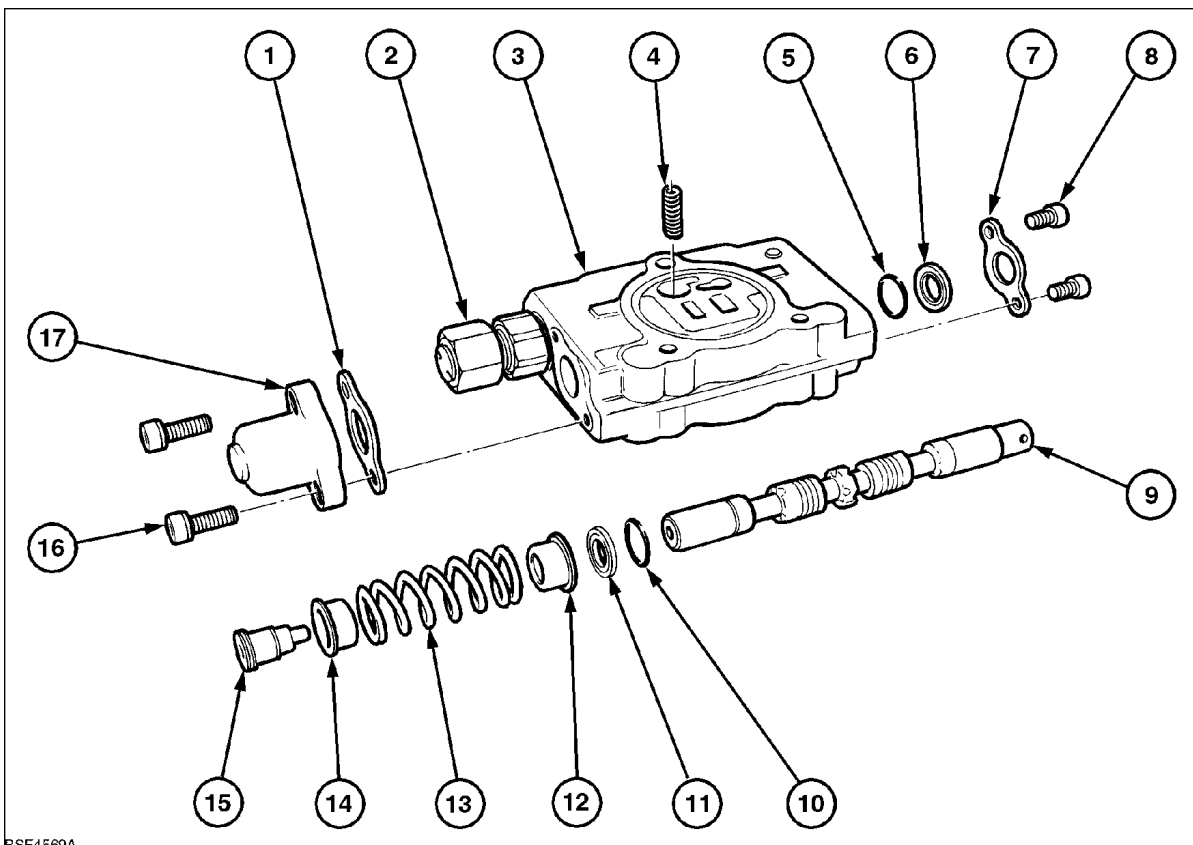

BSF4569A

BSF4569A 1

Control Valve less Detent (Bucket) Components

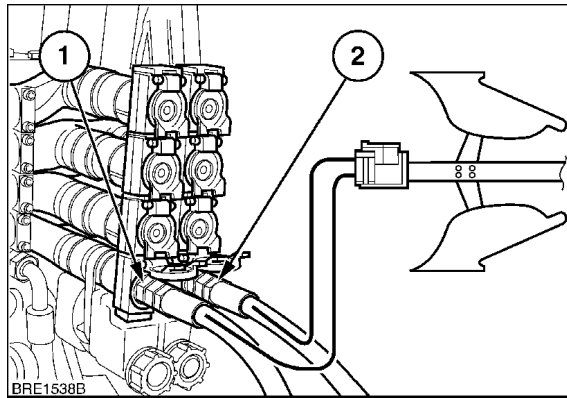

BRE1538B 14

OPERATING CONTINUOUS FLOW HYDRAULIC EQUIPMENT

Continuous flow hydraulic equipment (e.g., hydraulic motors) should be connected to the 1st remote control valve couplers with the pressure hose connected to the right retract coupler and the return hose connected to the low pressure return circuit.

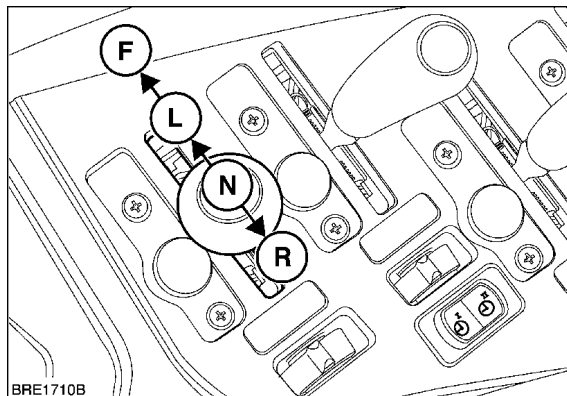

BRE1710B_488 15

The flow control should be adjusted to regulate the motor speed. If the flow control is open too far, the 3-point hitch and other remote valves will slow down or stop. Using the flow control this way will ensure that the hydraulic system will only supply the oil required by the motor.

With the remote control valve lever fully forward in the "float" (4) position, the motor will be stationary. The hydraulic motor will operate if the lever is pulled back to the "retract" (3) position. To stop the motor, move the lever from the retract position to the float position. In the float position the motor will be able to stop slowly, which will not damage the motor.

NOTICE: When operating continuous flow equipment, the remote control valve lever must not be moved rearward to the neutral or raise positions as damage to the equipment may result.

Observe the following to further protect the tractor and equipment.

- Do not open any bypass valve in the equipment or motor. Use the flow control to regulate the rate of flow or speed of the motor.
- Do not hold the remote control valve lever to operate the equipment.
- To ensure optimum hydraulic oil cooling, operate continuous flow equipment at the highest flow setting (by use of the flow control) and lowest engine speed that will give the required machine performance and speed.

OPERATING SEVERAL REMOTE VALVES SIMULTANEOUSLY OR REMOTE VALVES AND HYDRAULIC LIFT SIMULTANEOUSLY

If operating two or more remote control valves simultaneously or remote valves and the hydraulic lift, all the flow control valves (1), should be adjusted using the enhanced keypad to provide a partial flow, as previously described. If not so adjusted, all the available flow may be directed to the full flow circuit when the pressure in that circuit is less than that of the other circuits in use.

Hydraulic pump - Visual inspection (Steering / Low Pressure)

1. Wash all components using a suitable degreaser.
2. Inspect the O-ring seal groove and the shaft oil seal recess in the mounting flange, these should be undamaged and free from burrs.
3. Examine the gears, shafts, and bearing blocks for wear. The pump must be renewed if:

- The PTFE coated bearings (**1**) in the bearing blocks are worn through revealing the bronze backing.
- The gear side faces are scored. This concern is often caused by contaminated oil.
- There is a distinctive wear step on the side faces of the gears and bearing blocks.

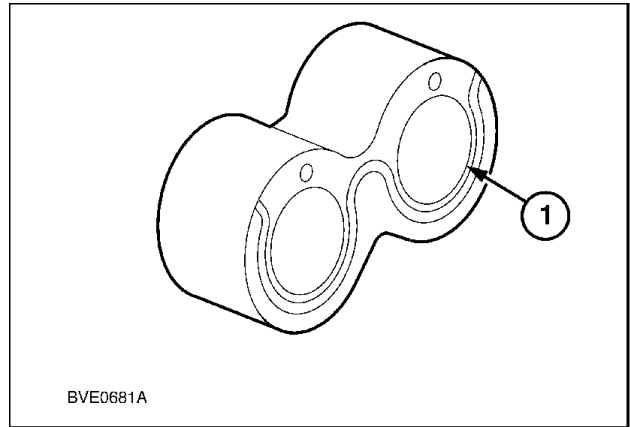

BVE0681A 1

NOTICE: When servicing the pump gears, particular attention must be paid to the following points:

- The width of each gear set must be within **0.005 mm (0.0002 in)** of each other to ensure satisfactory pump efficiency.
- Journals must be within **0.013 mm (0.00051 in)** of each other.
- Gear faces must be flat. This feature may be checked using engineers blue on the bearing face and rotating against the gear. This check will also reveal any sharp edges on the teeth.

3. Remove the fuel tank rear securing strap (1) from the fuel tank support and pull the fuel tank out. This will improve the access to the low pressure distribution block.

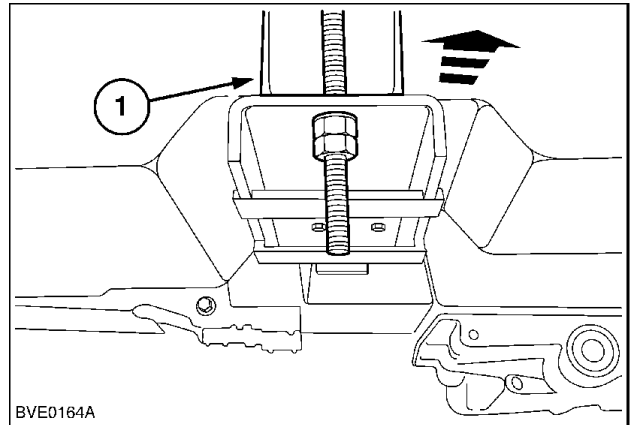

BVE0164A 3

4. Remove the test port plug and install the adaptor 380000493 (1), 7/16 - 20 JIC male x 7/16 - 20 UNF male (3) and the 90° quick release fitting 380001146 (2).
Install the adaptor 380000572 and the quick release fitting 380000492 for the PTO brake pressure test.
• Test port thread M10 x 1.0

NOTE: Adaptor is shown in the Four Wheel Drive test port.

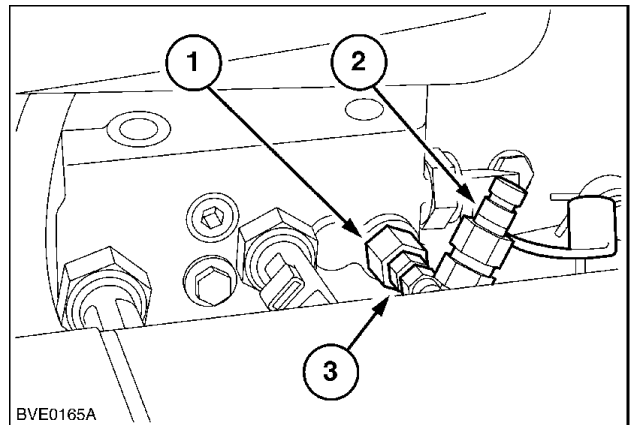

BVE0165A 4

5. Attach a 0 - 40 bar (0 - 580 psi) pressure gauge 380000552 (1), using the quick release coupler 380000543 (2) and the hose 380000545.
Set the engine speed to 1500 RPM to observe the system operation pressure or 2200 RPM for the maximum system pressure.
Operate the component to be tested, the pressure reading should be 17 - 19 bar (247 - 276 psi).

NOTE: Pressure is only present at the four wheel drive pressure test port when four wheel drive is disengaged. Pressure is not present when four wheel drive is engaged or the parking brake is applied.

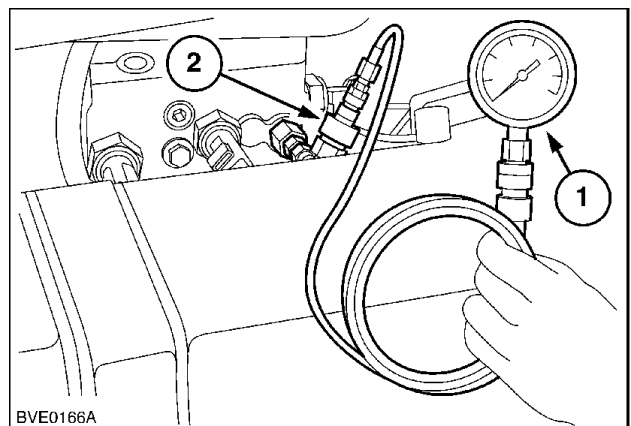

BVE0166A 5

6. If there is no change in pressure when the component is operated, but the low pressure system test pressures are within specification. The fault could be either with the solenoid or the wiring. Check for voltage at the respective connector. If +12 v is available suspect the solenoid, if no voltage is seen suspect the wiring.

Fuse and relay box - Static description

Fuses and Relays

NOTICE: Do not replace a blown fuse with another of a different rating.

The fuse box is located behind a panel on the top of the right hand control console. To check or change fuses, remove the two screws securing the panel to the console. In addition to the main fuses there are additional 'Maxi' fuses which are provided to protect the main fuses and electrical circuit.

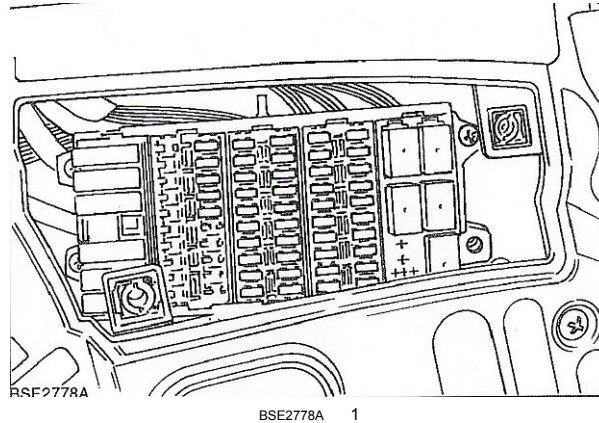

There is provision for 60 fuses although they may not all be fitted, depending on the specification of the tractor. The fuses are numbered and colour coded

Refer to **Fuse and relay box - General specification (A.30.A)** for fuse positions and descriptions.

More relays are located behind the front of the right hand control console.

Refer to **Fuse and relay box - General specification (A.30.A)** for relay functions.

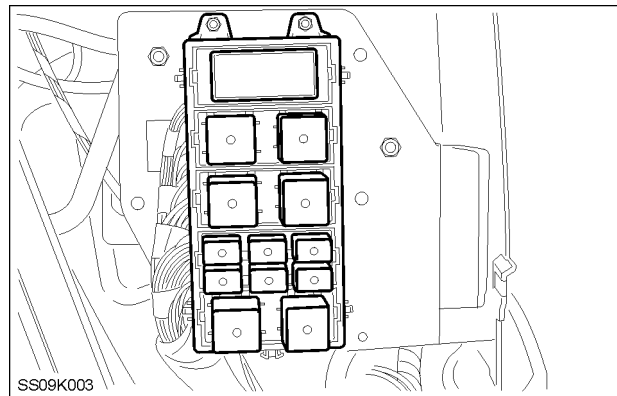

Connector - Component diagram 04 Connectors 40-49

C041 PTO SOLENOID

POS.	WIRE NUMBER	CIRCUIT REFERENCE
1	2042 (O)	PTO SOLENOID-REAR
2	2051 (O)	PTO SOLENOID RETURN (-)

NOTE: For the wiring color code refer to, **Wiring harness - Overview (A.30.A)**.

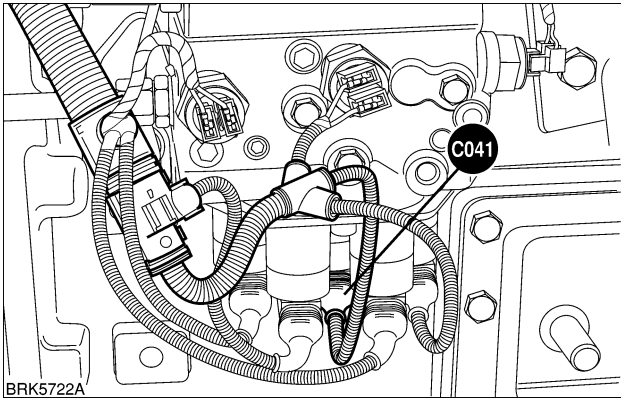

C041V-BRK5722A 1

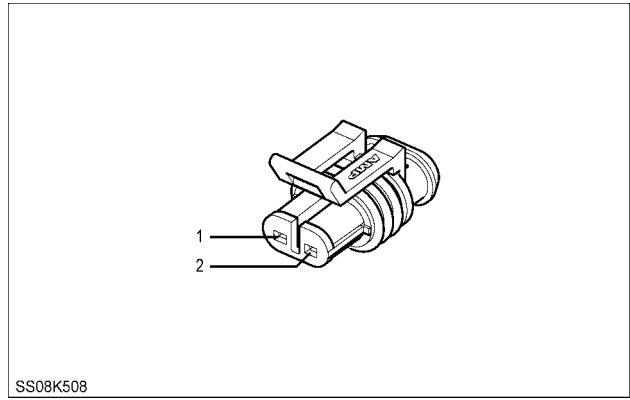

SS08K508

SS08K508 2

LEFT HAND SIDE TRANSMISSION

C085 RIGHT HAND UPPER FRONT WORKLAMP

POS.	WIRE NUMBER	CIRCUIT REFERENCE
A	1098B (W)	FRONT WORKLAMP RELAY GROUND
B	57AA (B)	EARTH (ALL)

NOTE: For the wiring color code refer to, **Wiring harness - Overview (A.30.A)**.

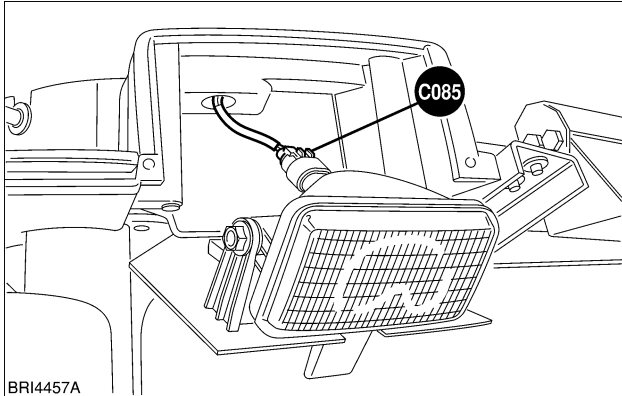

C085-BRI4457A 9

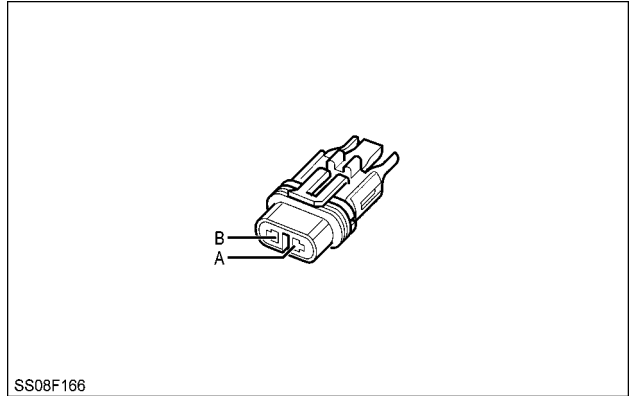

SS08F166 10

RIGHT HAND SIDE FRONT CAB ROOF

C138 SEAT AIR PUMP

POS.	WIRE NUMBER	CIRCUIT REFERENCE
1	181L (G)	BLOWER MOTOR FEED
2	2069 (O)	PTO MANAGEMENT ON
3	181K (G)	BLOWER MOTOR FEED
4	57CN (B)	EARTH (ALL)

NOTE: For the wiring color code refer to, *Wiring harness - Overview (A.30.A)*.

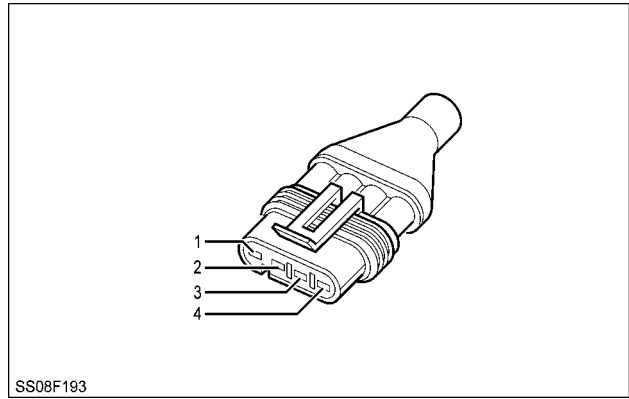
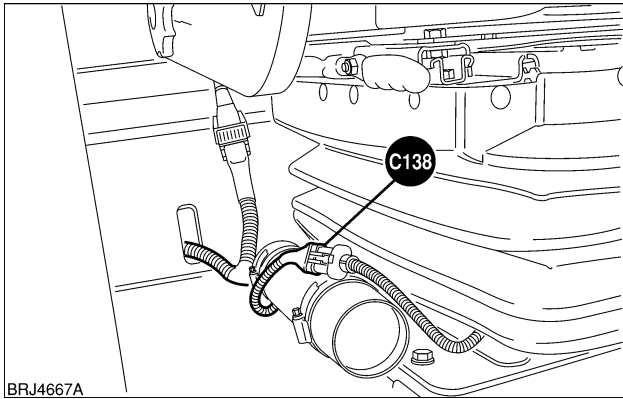

RIGHT HAND SIDE OF OPERATOR'S SEAT

C239 TCM TRANSMISSION CONTROL MODULE (CN2)

POS.	WIRE NUMBER	CIRCUIT REFERENCE
1	7915 (L)	TCM CLUTCH B RETURN
2	7225 (W)	TRANS HI RANGE SOL - RET
3	7935 (L)	TCM CLUTCH D RETURN
4	5087 (K)	EDC VALVE UP RETURN
5	5097 (K)	EDC VALVE DOWN RETURN
6	7925 (L)	TCM CLUTCH C RETURN
7	7982 (W)	TRANS MED. RANGE RET
8	7900 (TQ)	CLUTCH 'A' SIGNAL
11	5220 (Y)	EDC RAISE LAMP
13	9034 (LN)	50KPH SOLENOID-
14	2062 (W)	PTO TWIST SENSOR
16	3168 (O)	AUTO GUIDANCE DUMP SOLENOID FEED (HSD)
19	5180 (TQ)	EDC SLIP INDICATOR LAMP
20	2140 (O)	PTO SPEED SENSOR
21	57W (B)	EARTH (ALL)
22	5596 (S)	EHR MASTER STOP LAMP
23	6355 (R)	+5V LOW POWER REFERENCE
24	5110 (K)	EDC LAMP SIGNAL
25	5230 (Y)	EDC LOWER LAMP
26	57X (B)	EARTH (ALL)

NOTE: For the wiring color code refer to, **Wiring harness - Overview (A.30.A)**.

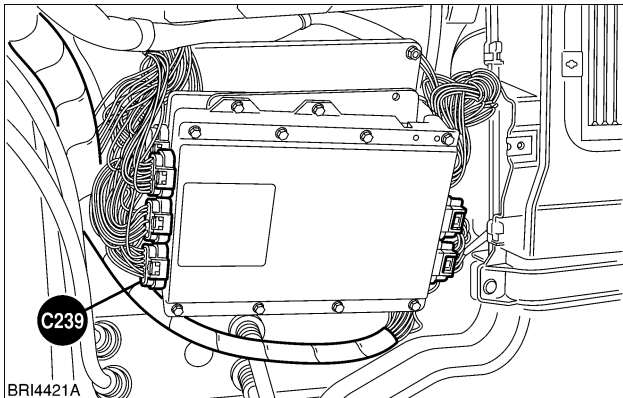

C239-BRI4421A 7

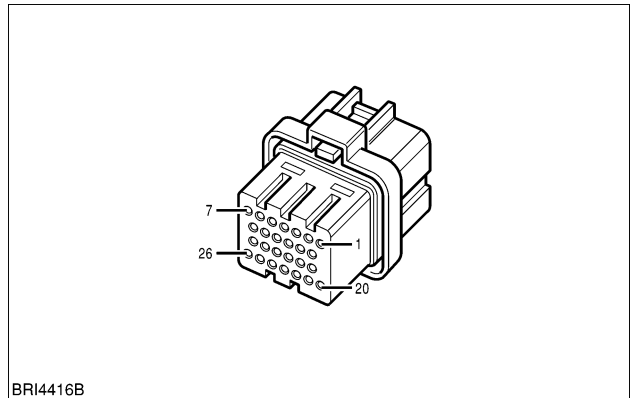

BRI4416B

BRI4416B-01 8

BEHIND OPERATOR'S SEAT

C314 HAND THROTTLE

POS.	WIRE NUMBER	CIRCUIT REFERENCE
1	5200F (N)	EDC VALVE SUPPLY
2	6440A (S)	HAND THROTTLE POSITION 1
4	6460A (S)	HAND THROTTLE SWITCH (NOT IDLE)
5	5020D (LN)	EDC PROC +5V REF VOLTAGE DROP POSN/RATE
6	60J (B/W)	SENSOR GROUND

NOTE: For the wiring color code refer to, **Wiring harness - Overview (A.30.A)**.

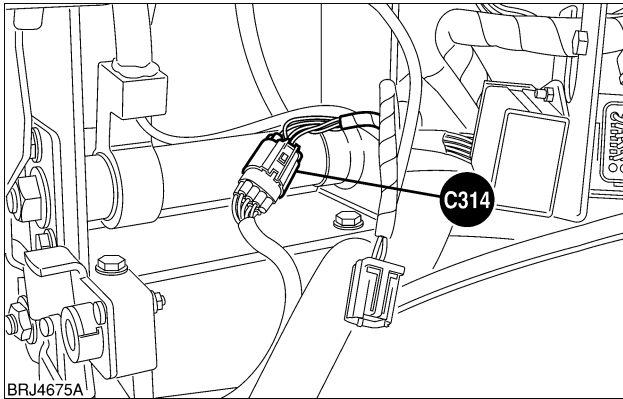

C314-BRJ4675A 3

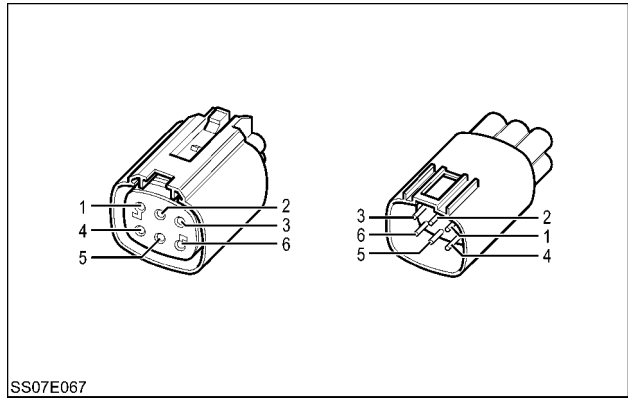

SS07E067

SS07E067 4

RIGHT HAND CONSOLE

C378 SWITCH PANEL

POS.	WIRE NUMBER	CIRCUIT REFERENCE
A1	7000 (U) / 7000A (U)	TRANS CONTROL SUPPLY
A2	5640 (R)	HTS AUTO SWITCH
A3	7476 (R)	TRANS AUTO ON
A4	3025 (Y)	FOUR WHEEL DRIVE SOLENOID (MANUAL)
A5	3027 (Y)	FOUR WHEEL DRIVE SOLENOID (AUTO)
A6	7120 (Y)	DIFF-LOCK WNG LP (MAUAL)
A7	7125 (LG) / 7125 (G)	DIFF-LOCK WNG LP (AUTO)
A8	7170 (W)	DIFF LOCK SWITCH (AUTO ON)
B1	7175 (Y)	DIFF LOCK SWITCH (MANUAL ON)
B2	5630 (R)	HTS MANUAL SWITCH
B3	6620 (N)	ECU COOLANT TEMP. SIGNAL
B4	6530 (N)	CONSTANT ERPM INCREASE
B5	6540 (N)	CONSTANT ERPM DECREASE
B6	7040 (N)	TRANS CREEPER SWITCH
B7	2067 (R) / 2069 (U)	/ PTO MANAGEMENT ON
B8	57AD (B) / 57 (B)	EARTH (ALL)
C1	2050A (G) / 2050 (G)	PTO SUPPLY / DOG SUPPLY
C2	3210 (U)	SUSPENSION SWITCH RETURN
C3	3290 (O)	SUSPENSION LOCKOUT LAMP (OR SOLENOID RET)
C5	5610 (R)	HTS PROGRAM
C7	6510 (N)	CONSTANT ERPM SET 1
C8	9027 (W)	CAL/ SEL INPUT ADIC

NOTE: For the wiring color code refer to, **Wiring harness - Overview (A.30.A)**.

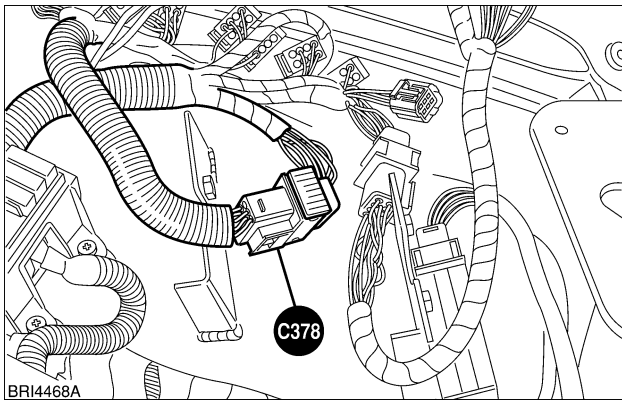

C378-BRI4468A 11

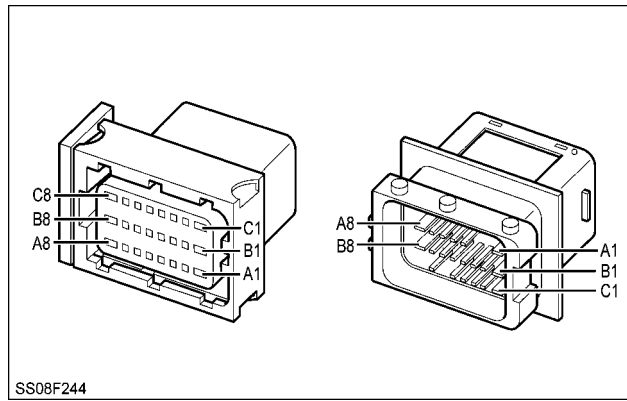

SS08F244

SS08F244 12

RIGHT HAND CONSOLE

C436 CYLINDER INJECTOR 3 AND 4 (EDC 16)

POS.	WIRE NUMBER	CIRCUIT REFERENCE
1	(W/G) *(S/Q)	
2	(O/U) *(W/U)	
3	(S/B)	
4	(B/P) *(N/G)	

NOTE: For the wiring color code refer to, **Wiring harness - Overview (A.30.A)**.

* With 4 cylinders.

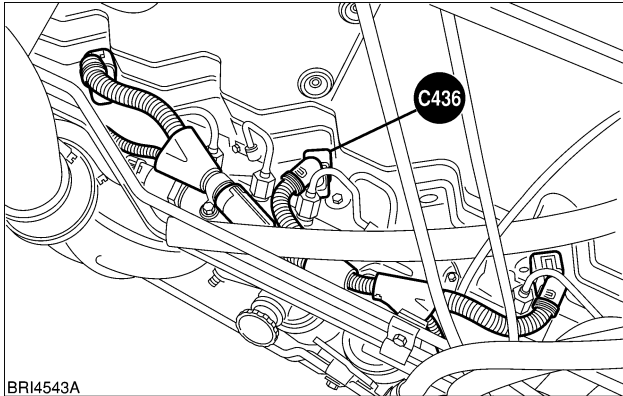

C436-BRI4543A 11

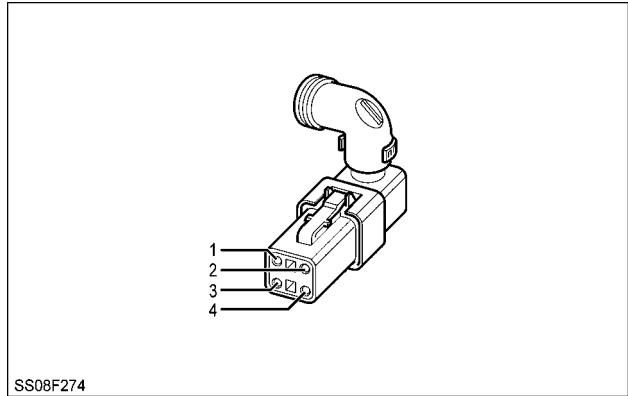

SS08F274 12

TOP LEFT HAND SIDE ENGINE

C438 CYLINDER INJECTOR 5 AND 6 (EDC 16)

POS.	WIRE NUMBER	CIRCUIT REFERENCE
1	(U/B)	
2	(O/W)	
3	(U/R)	
4	(Y/B)	

NOTE: For the wiring color code refer to, **Wiring harness - Overview (A.30.A)**.

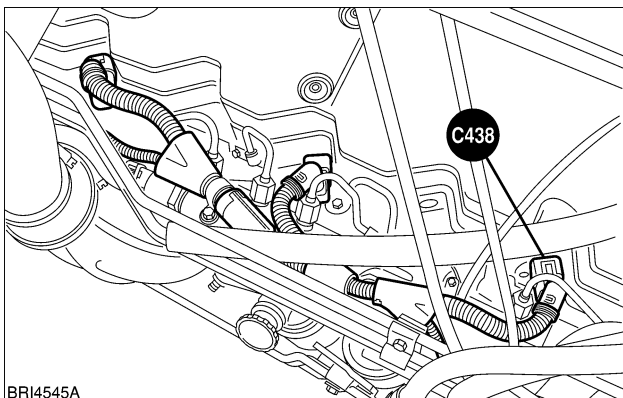

C438-BRI4545A 13

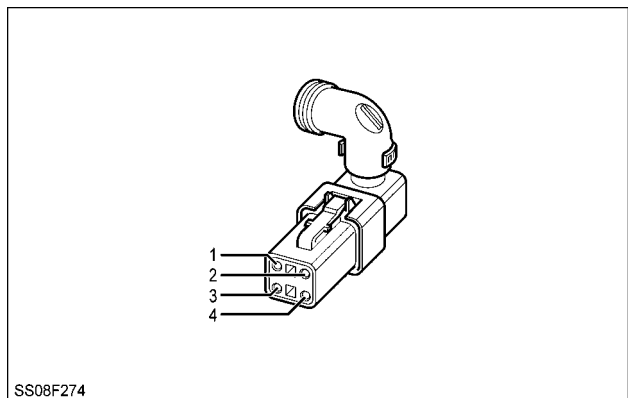

SS08F274 14

TOP LEFT HAND SIDE ENGINE

C559 AIR CONDITIONING POWER

POS.	WIRE NUMBER	CIRCUIT REFERENCE
1	982B (G) / (R)	POWER SUPPLY BLOWER MOTOR
2	982C (G) / (R)	POWER SUPPLY BLOWER MOTOR
3	57NZ (B)	EARTH (ALL)
4	57PA (B)	EARTH (ALL)

NOTE: For the wiring color code refer to, **Wiring harness - Overview (A.30.A)**.

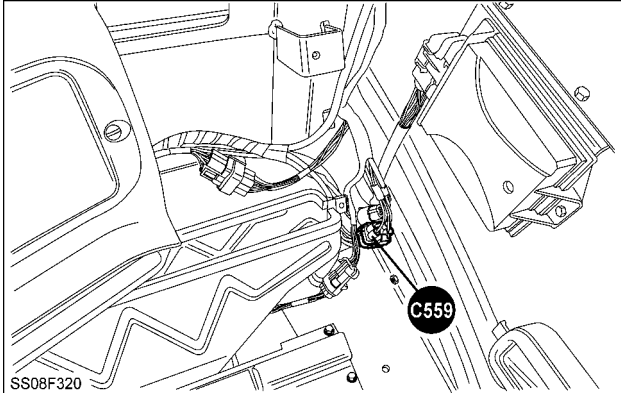

SS08F320 9

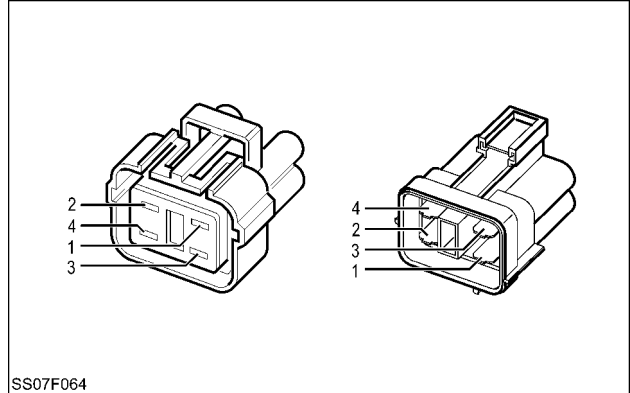

SS07F064 10

LEFT HAND SIDE BEHIND OPERATOR'S SEAT

C907 OUTLET TEMPERATURE SENSOR

POS.	WIRE NUMBER	CIRCUIT REFERENCE
1	9222 (Y)	AC-SIGNAL OUTLET TEMPERATURE SENSOR
2	57ZH (B)	EARTH (ALL)

NOTE: For the wiring color code refer to, *Wiring harness - Overview (A.30.A)*.

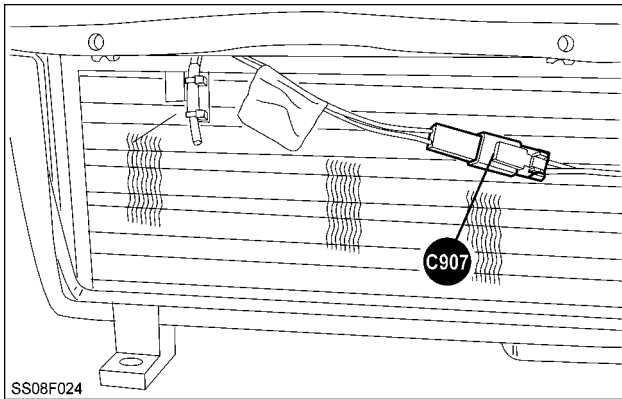

SS08F024 11

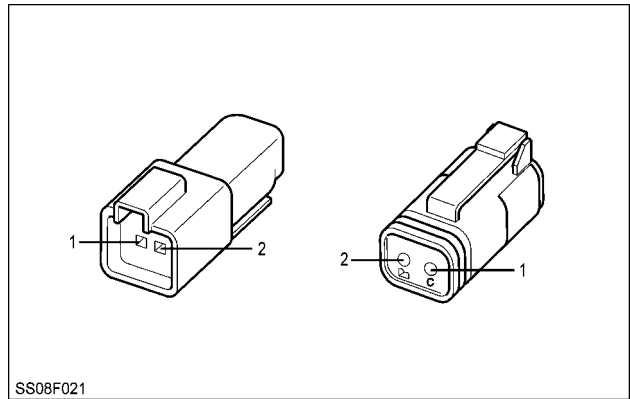

SS08F021 12

UNDER THE SEAT

C908 EVAP EVAPORATOR TEMPERATURE SENSOR

POS.	WIRE NUMBER	CIRCUIT REFERENCE
1	9221 (Y)	AC-EVAPORATOR TEMPERATURE SENSOR
2	57ZH (B)	EARTH (ALL)

NOTE: For the wiring color code refer to, *Wiring harness - Overview (A.30.A)*.

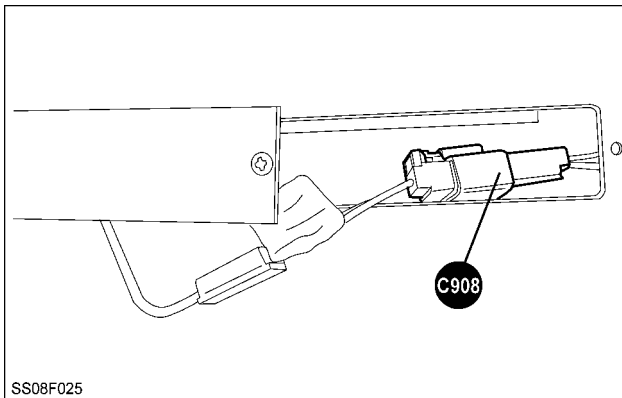

SS08F025 13

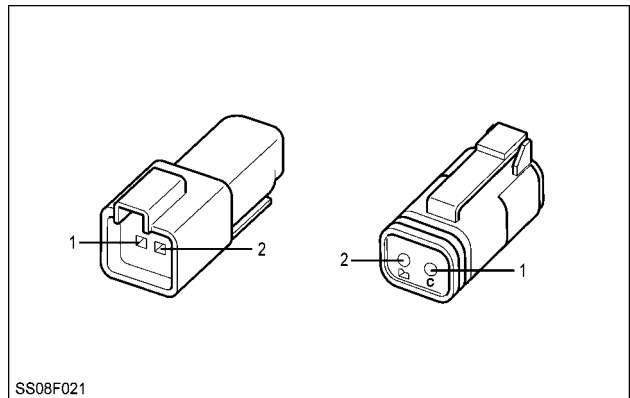

SS08F021 14

UNDER THE SEAT

Wiring harness - Electrical schematic frame 09 Transmission 2

T6030 4v W/Cab 16x16, T6050 4v W/Cab 16x16, T6070 4v W/Cab 16x16, T6020 4v W/Cab 16x16, T6060 4v W/Cab 16x16, T6040 4v W/Cab 16x16

Component	Connector	Description
A001	C104	Gearshift Indicator
B13	C077	Clutch Potentiometer
B16	C046	Axle Speed Sensor
S18	C192	Creeper Gear Switch
S19	C036	Trans Oil Pressure Switch
S20	C262	Trans Auto Function Switch
X4	C444	Trans Can
Y10	C360	5-8 Synchro Solenoid

Additional Connectors:

C019 C020 C079 C081 C101 C127 C128 C239 C378

Wire Colour Codes

B	Black	R	Red	LG	Light Green	K	Pink
N	Brown	O	Orange	U	Blue	W	White
LN	Light Brown	Y	Yellow	TQ	Turquoise		
S	Slate	G	Green	L	Lilac		

Wiring harness - Electrical schematic frame 23 Cab Accessories 2

T6030 4v W/Cab 16x16, T6050 4v W/Cab 16x16, T6070 4v W/Cab 16x16, T6020 4v W/Cab 16x16, T6060 4v W/Cab 16x16, T6040 4v W/Cab 16x16

Component	Connector	Description		
F19		Heated Mirrors Fuse 15 A		
H8	C092	Console Lamp		
K21		Heated Mirrors Relay		
M2	C607	Electric Mirror L.H.		
M3	C608	Electric Mirror R.H.		
S46	C609	Mirror Control		
S47	C551	Heated Mirror Switch		
Additional Connectors: C532				
Wire Colour Codes				
B	Black	R Red	LG Light Green	K Pink
N	Brown	O Orange	U Blue	W White
LN	Light Brown	Y Yellow	TQ Turquoise	
S	Slate	G Green	L Lilac	

Wiring harness - Electrical schematic frame 37 Processors 1

T6030 4v W/Cab 16x16, T6050 4v W/Cab 16x16, T6070 4v W/Cab 16x16, T6020 4v W/Cab 16x16, T6060 4v W/Cab 16x16, T6040 4v W/Cab 16x16

Component	Connector	Description			
A009	C100	XCM Central Control Unit (CN1-A)			
A010	C324	XCM Auxiliary Controller (CN1-A)			
A011	C079	Instrument Panel A			
F34		ADIC Battery Pos. Fuse 10 A			
F35		EDC Memory / SCM / ACM Fuse 10 A			
F36		Instrument Cluster Ignition Fuse 10 A			
F37		Transmission Ignition Fuse 15 A			
F38		Rear PTO Ignition / Rear PTO Switch & Lamp / HPL Fuse 10 A			
F41		Front PTO Fuse 15 A			
K17		Electronics Supply Relay			
MF3		Maxi Fuse 80 A			
Additional Connectors: C001 C619					
Wire Colour Codes					
B	Black	R Red	LG Light Green	K	Pink
N	Brown	O Orange	U Blue	W	White
LN	Light Brown	Y Yellow	TQ Turquoise		
S	Slate	G Green	L Lilac		

Wiring harness - Electrical schematic frame 11 EDC HYDRAULICS 1

T6030 2v W/Cab 16x16, T6050 2v W/Cab 16x16, T6070 2v W/Cab 16x16, T6010 2v W/Cab 16x16, T6020 2v W/Cab 16x16

Component	Connector	Description					
B17	C047	LH Draft Pin					
B18	C052	Rockshaft Potentiometer					
B19	C048	RH Draft Pin					
B20	C170	Front Hitch Position Potentiometer					
F42		Front Suspension / HPL Fuse 10 A					
S21	C023	Trans Oil Temperature Sensor					
Additional Connectors: C019 C101 C269 C324 C325 C392							
Wire Colour Codes							
B	Black	R	Red	LG	Light Green	K	Pink
N	Brown	O	Orange	U	Blue	W	White
LN	Light Brown	Y	Yellow	TQ	Turquoise		
S	Slate	G	Green	L	Lilac		

Wiring harness - Electrical schematic frame 26 Main Lamps / Indicators 2

T6030 2v W/Cab 16x16, T6050 2v W/Cab 16x16, T6070 2v W/Cab 16x16, T6010 2v W/Cab 16x16, T6020 2v W/Cab 16x16

Component	Connector	Description					
F7		Main Light Switch & Hazard Switch Fuse 20 A					
F13		Stoplamps Fuse 15 A					
F14		Main Light Switch / Flasher Unit Fuse 15 A					
F25		Headlamps Dipped Beam Fuse 15 A					
F26		Headlamps Main Beam Fuse 15 A					
K4		Side & Illumination Lights Relay					
K7		Headlamps Dipped Beam Relay					
K8		Stoplamps Relay					
K9		Headlamps Main Beam Relay					
S52	C074	Turn Switch					
S53	C083	Hazard Switch					
Additional Connectors: C001 C020 C056 C081 C374							
Wire Colour Codes							
B	Black	R	Red	LG	Light Green	K	Pink
N	Brown	O	Orange	U	Blue	W	White
LN	Light Brown	Y	Yellow	TQ	Turquoise		
S	Slate	G	Green	L	Lilac		

Wiring harness - Electrical schematic frame 40 Air Con Auto

T6030 2v W/Cab 16x16, T6050 2v W/Cab 16x16, T6070 2v W/Cab 16x16, T6010 2v W/Cab 16x16, T6020 2v W/Cab 16x16

Component	Connector	Description
A020		Heater / Air Con Connector
A021	C628	Auto Temp Control
B34		Heater Air Con Connector
B35		Heater Air Con Connector
B36		HVAC Unit
B37		HVAC Unit
B38		Temp Control
M9		Heater / Air Con Connector
S65		HVAC Unit
S66		Heater Blower Switch
S67		Air Con Switch
Y43		HVAC Unit

Additional Connectors:

C119 C362 C557 C559 C627 C629 C630

Wire Colour Codes

B	Black	R	Red	LG	Light Green	K	Pink
N	Brown	O	Orange	U	Blue	W	White
LN	Light Brown	Y	Yellow	TQ	Turquoise		
S	Slate	G	Green	L	Lilac		

Wiring harness - Electrical schematic frame 14 EHR HYDRAULICS 1

T6030 2v W/Cab 24x24, T6050 2v W/Cab 24x24, T6070 2v W/Cab 24x24, T6010 2v W/Cab 24x24, T6020 2v W/Cab 24x24

Component	Connector	Description					
S83	C395	EHR Switch 3/4 Time Flow					
S84	C400	EHR 3-4 Lever Assy					
S85	C390	EHR 1-2 Lever Assy					
S86	C394	EHR Switch 1/2 Time Flow					
Additional Connectors: C325 C327 C328 C392 C393							
Wire Colour Codes							
B	Black	R	Red	LG	Light Green	K	Pink
N	Brown	O	Orange	U	Blue	W	White
LN	Light Brown	Y	Yellow	TQ	Turquoise		
S	Slate	G	Green	L	Lilac		

Wiring harness - Electrical schematic frame 29 Main Lamps / Indicators 3 - LP Roof

T6030 2v W/Cab 24x24, T6050 2v W/Cab 24x24, T6070 2v W/Cab 24x24, T6010 2v W/Cab 24x24, T6020 2v W/Cab 24x24

Component	Connector	Description
A007	C260	Indicator Flasher Unit Connector
H29	C519	Grabrail Sidelamp R.H. - Roof
H30	C525	SMV Lamp R.H. Rear - Roof
H31	C520	SMV Lamp R.H. Front - Roof
H32	C528	Grabrail Sidelamp L.H. - Roof
H33	C526	SMV Lamp L.H. Rear - Roof
H34	C529	SMV Lamp L.H. Front - Roof
Additional Connectors: C020 C079 C081 C532		

Wiring harness - Electrical schematic frame 02 Engine 1 - Europe

T6030 2v L/Cab 16x16, T6050 2v L/Cab 16x16, T6070 2v L/Cab 16x16, T6010 2v L/Cab 16x16, T6020 2v L/Cab 16x16

Component	Connector	Description
F9		Loader Option Fuse 25 A
K22	C669	European Loader Relay 1
K23	C670	European Loader Relay 2
S3	C376	Foot Throttle - Electronic engine
X3	C369	Loader Control Joystick
Y2	C414	Loader Valve 2
Y3	C413	Loader Valve 1
Additional Connectors: C127 C128 C269 C424 C441 C442 C647 C648		

Wiring harness - Electrical schematic frame 17 Power Take Off 1

T6030 2v L/Cab 16x16, T6050 2v L/Cab 16x16, T6070 2v L/Cab 16x16, T6010 2v L/Cab 16x16, T6020 2v L/Cab 16x16

Component	Connector	Description					
H1	C117	Rear PTO Engage Lamp					
H2	C114	Front PTO Engage Lamp					
S37	C044	Ground Speed PTO Engaged					
S38	C118	Rear PTO Brake Switch & Lamp					
S39	C116	Rear PTO Switch					
S40	C115	Front PTO Switch					
X8	C649	Ground Speed PTO Link Connector					
X9	C635	Rear PTO Brake Switch Jumper					
Additional Connectors: C020 C127 C128 C324 C325 C326 C328 C649							
Wire Colour Codes							
B	Black	R	Red	LG	Light Green	K	Pink
N	Brown	O	Orange	U	Blue	W	White
LN	Light Brown	Y	Yellow	TQ	Turquoise		
S	Slate	G	Green	L	Lilac		

Wiring harness - Electrical schematic frame 32 Trailer Brakes

T6030 2v L/Cab 16x16, T6050 2v L/Cab 16x16, T6070 2v L/Cab 16x16, T6010 2v L/Cab 16x16, T6020 2v L/Cab 16x16

Component	Connector	Description		
F16		Trailer Brakes Fuse 15 A		
K10		Trailer brake Supply (Pneumatic) Relay		
K11		Trailer Brake Supply (Hydraulic) Relay		
S58	C136	Handbrake Switch		
S59	C410	Italian Trailer Brake - Line Pressure Switch		
S60	C409	Italian Trailer Brake - Pump Pressure Switch		
S61	C407	Air Brake Pressure Switch		
X17	C050	Trailer Brake Connector		
X18		Trailer Socket		
X19	C144	Air Brake Connector		
Y38	C408	Italian Trailer Brake Solenoid		
Y39	C408	Italian Trailer Brake Solenoid		
Y40	C406	Air Brake Solenoid		
Y41	C576	Brake De-icer - Trailer Brakes		
Y42	C577	Park Brake Solenoid - Trailer Brakes		
Additional Connectors: C020 C055 C081 C127				
Wire Colour Codes				
B	Black	R Red	LG Light Green	K Pink
N	Brown	O Orange	U Blue	W White
LN	Light Brown	Y Yellow	TQ Turquoise	
S	Slate	G Green	L Lilac	

Wiring harness - Electrical schematic frame 06 Engine 4

T6030 2v L/ Cab 24x24, T6050 2v L/ Cab 24x24, T6070 2v L/ Cab 24x24, T6010 2v L/ Cab 24x24, T6020 2v L/ Cab 24x24

Component	Connector	Description					
B4	C017	Water in Fuel Sensor					
B40	C255	Engine Speed Sensor					
F21		Grid Heater / WIF Sensor / Brake Fluid Level Fuse 15 A					
K25	C354	Grid Heater Relay					
R4	C626	Fuel Heater					
Additional Connectors: C001 C079 C269							
Wire Colour Codes							
B	Black	R	Red	LG	Light Green	K	Pink
N	Brown	O	Orange	U	Blue	W	White
LN	Light Brown	Y	Yellow	TQ	Turquoise		
S	Slate	G	Green	L	Lilac		

Wiring harness - Electrical schematic frame 21 Cab Accessory 1 - ISO & NASO Roof

T6030 2v L/ Cab 24x24, T6050 2v L/ Cab 24x24, T6070 2v L/ Cab 24x24, T6010 2v L/ Cab 24x24, T6020 2v L/ Cab 24x24

Component	Connector	Description
F1		Park Brake Status Fuse 10 A
F4		Accessory Sockets Fuse 10 A
F17		Accessory Sockets Fuse 25 A
MF6		Maxi Fuse 80 A

Wiring harness - Electrical schematic frame 36 Diagnostics 1

T6030 2v L/ Cab 24x24, T6050 2v L/ Cab 24x24, T6070 2v L/ Cab 24x24, T6010 2v L/ Cab 24x24, T6020 2v L/ Cab 24x24

Component	Connector	Description					
F33		Diagnostic Socket / Engine ECU Fuse 25 A					
R3	C292	Terminating Resistor Connector					
X21	C375	ADIC Diagnostic Connector					
Additional Connectors: C001 C080 C081 C100 C101 C269 C324							
Wire Colour Codes							
B	Black	R	Red	LG	Light Green	K	Pink
N	Brown	O	Orange	U	Blue	W	White
LN	Light Brown	Y	Yellow	TQ	Turquoise		
S	Slate	G	Green	L	Lilac		

Wiring harness - Electrical schematic frame 10 Transmission 3

T6030 2v W/Cab 12x12, T6050 2v W/Cab 12x12, T6010 2v W/Cab 12x12, T6020 2v W/Cab 12x12

Component	Connector	Description
-----------	-----------	-------------

Wiring harness - Electrical schematic frame 25 Main Lamps / Indicators 1

T6030 2v W/Cab 12x12, T6050 2v W/Cab 12x12, T6010 2v W/Cab 12x12, T6020 2v W/Cab 12x12

Component	Connector	Description					
D4	C377	Diode					
F22		Sidelamps R.H. Fuse 15 A					
F23		Sidelamps L.H. Fuse 15 A					
F24		Illumination Fuse 10 A					
H14	C094	NASO Rear Flasher R.H.					
H15	C131	Licence Plate Lamp - may or may not be fitted.					
H16	C131	Licence Plate Lamp - may or may not be fitted.					
H17	C095	Rear Licence worklamp L.H.- may or may not be fitted.					
H18	C096	Rear Licence worklamp R.H.- may or may not be fitted.					
H19	C129	Fender Worklamp R.H.					
H20	C130	Fender Worklamp L.H.					
H55	C093	NASO Rear Flasher L.H.					
S49	C425	Aux Headlamp Switch					
S50	C257	Fender PTO Switch L.H.					
S51	C258	Fender PTO Switch R.H.					
Additional Connectors: C001 C020 C056 C293 C294 C295 C296 C532							
Wire Colour Codes							
B	Black	R	Red	LG	Light Green	K	Pink
N	Brown	O	Orange	U	Blue	W	White
LN	Light Brown	Y	Yellow	TQ	Turquoise		
S	Slate	G	Green	L	Lilac		

Wiring harness - Electrical schematic frame 40 Air Con Auto

T6030 2v W/Cab 12x12, T6050 2v W/Cab 12x12, T6010 2v W/Cab 12x12, T6020 2v W/Cab 12x12

Component	Connector	Description
A020	C628	Heater / Air Con Connector
A021		Auto Temp Control
B34		Heater Air Con Connector
B35		Heater Air Con Connector
B36		HVAC Unit
B37		HVAC Unit
B38		Temp Control
M9		Heater / Air Con Connector
S65		HVAC Unit
S66		Heater Blower Switch
S67		Air Con Switch
Y43		HVAC Unit

Additional Connectors:

C119 C362 C557 C559 C629 C630

Wire Colour Codes

B	Black	R	Red	LG	Light Green	K	Pink
N	Brown	O	Orange	U	Blue	W	White
LN	Light Brown	Y	Yellow	TQ	Turquoise		
S	Slate	G	Green	L	Lilac		

Wiring harness - Electrical schematic frame 14 EHR HYDRAULICS 1

T6030 2v L/Cab 12x12, T6050 2v L/Cab 12x12, T6010 2v L/Cab 12x12, T6020 2v L/Cab 12x12

Component	Connector	Description
-----------	-----------	-------------

Wiring harness - Electrical schematic frame 29 Main Lamps / Indicators 3 - LP Roof

T6030 2v L/Cab 12x12, T6050 2v L/Cab 12x12, T6010 2v L/Cab 12x12, T6020 2v L/Cab 12x12

Component	Connector	Description
-----------	-----------	-------------

HYDRAULIC - PNEUMATIC - ELECTRICAL - ELECTRONIC SYSTEMS - ELECTRICAL POWER SYSTEM

CIRC	COLOUR	DESCRIPTION
2100	G	A/C CONDENSER MOTOR FEED
2120	LN	PTO BRAKE SIGNAL
2130	N	PTO BRAKE SOLENOID
2140	O	PTO SPEED SENSOR
2150	P	PTO EXT. SWITCH OFF
2151	K	EPTO DRIVE RELAY UPPER SPEED
2152	K	ESPTO DRIVE RELAY LOWER SPEED
2153	R	ESPTO ACTUATOR UPPER SPEED
2154	N	ESPTO ACTUATOR LOWER SPEED
2155	N	ESPTO ACTUATOR POWER +12V
2156	N	ESPTO ACTUATOR POS SIGNAL
2157	U	ESPTO NEUTRAL
2158	N	ESPTO LOWER SPEED
2159	U	ESPTO UPPER SPEED
2200	G	SERVICE MODE INITIATE
2245	K	PTO FRONT - SWITCH TO MODULE (MOM)
2248	K	PTO FRONT - SWITCH (VCCS)
2250	K	PTO FRONT - SUPPLY
2260	O	PTO FRONT - SPEED SIGNAL
2270	O	PTO FRONT - WARNING LAMP
2300	P	THEORETICAL GROUND SPEED ISO 11786 SKT.PIN#2
2310	P	IN/OUT OF WORK-HPL MODE ISO11786 SKT.PIN#4
2320	P	TRUE GROUND SPEED ISO 11786 SKT.PIN#1
2330	P	PTO SPEED ISO11876 SKT.PIN#3
2500	N	FRONT HITCH SOLENOID
2510	N	FRONT HITCH POSITION SIGNAL
2520	N	FRONT HITCH SET POSITION SIGNAL
2530	N	FRONT HITCH V REF
2540	N	FRONT HITCH +12v IGN
2550	N	FRONT HITCH OVERRIDE SWITCH
2556	N/Y/S	FRONT HITCH SWITCH COMMON RAIL
2560	N	FRONT HITCH 0v REF
2570	R	FRONT HITCH RAISE SOLENOID
2571	S	FRONT HITCH RAISE SOLENOID RETURN(-)
2575	W	STEYR EFH TRANSPORT SIGNAL – BOSCH EFH MODULE
2576	W	STEYR EFH WORK SIGNAL – BOSCH EFH MODULE
2577	P	STEYR EFH DIAGNOSTIC LAMP – BOSCH EFH MODULE
2578	G	STEYR EFH TRANSPORT SWITCH – EOLBAU ARMREST
2579	N	STEYR EFH WORK SWITCH – EOLBAU ARMREST
2580	R	FRONT HITCH LOWER SOLENOID
2581	S	FRONT HITCH LOWER SOLENOID RETURN (-)
2582	LG	STEYR - EXT SWITCHES
2583	LN	STEYR - EXT SWITCHES
2584	W	OILMOTOR MODE
2585	LN	EFH RAISE SWITCH
2586	LN	EFH WORK SWITCH
2587	N	EFH EXTERNAL SWITCH +
2588	P	EFH EXTERNAL SWITCH UP
2589	R	EFH EXTERNAL SWITCH DOWN
2590	LN	EXTERNAL SWITCH FHPL UP
2591	LN	EXTERNAL SWITCH FHPL DOWN
2592	N	EFH VALVE DOWN +
2593	N	EFH VALVE DOWN -
2594	O	EFH POSITION SENSOR +
2595	P	EFH POSITION SENSOR SIGNAL
2596	R	EFH POSITION SENSOR -
2597	LN	EFH PRESSURE SENSOR SIGNAL

N°	Test Point	Expected Result	Other Result (Possible Cause)
2	Check Perform a state of charge test Battery - Testing (A.30.A)	Result Refer to Battery - General specification (A.30.A) . If battery is above 75% charge proceed to step 3.	Action The battery must be fully charged before proceeding to step 3 (Heavy load test, Battery - Testing (A.30.A)).
3	Check Perform a heavy load test (refer to Battery - Testing (A.30.A)).	Result Is the reading below 9.6 V ? Action If NO the battery has an acceptable output capacity and will accept a normal charge	Action If result is below 9.6 V the battery has an unacceptable output capacity and should be test charged before attempting a full recharge.

Battery - Testing Visual check

N°	Test Point	Expected Result	Other Result (Possible Cause)
1	Check Remove the battery cover. Visually check the battery, (correctly identify battery manufacturer, refer to Battery - Static description (A.30.A)). Is the battery case cracked or the battery posts broken?	Result No cracking evident and no damage to posts, proceed to step 2	Action A cracked case or broken posts may lead to electrolyte leakage, the battery should be replaced.
2	Check Are the cables and connections damaged, dirty or loose?	Result Cables in good condition, clean and tight on posts, proceed to step 3.	Action Clean, tighten, repair or replace cables as required and then proceed to step 3.
3	Check Is there corrosion around the battery terminals?	Result No corrosion, proceed to step 4	Action Clean the terminals using water and sodium bicarbonate (baking soda). A wire brush may be required to remove heavy corrosion. Dry the battery and proceed to step 4
4	Check Is the battery strap or clamp loose?	Result Battery secure, proceed to step 5.	Action Tighten as necessary and proceed to step 5.
5	Check Check the electrolyte fluid level. The electrolyte should be around 17mm above the plates. Is the electrolyte level low in any of the cells?	Result Electrolyte at correct level, proceed to step 6.	Action Electrolyte level low, top up using distilled or de-mineralised water. Do not use tap or rain water. Proceed to step 6.
6	Check Using a hydrometer, Is the electrolyte excessively cloudy or discoloured ?	Result Electrolyte is clear, proceed to 'state of charge test', refer to Battery - Testing (A.30.A) .	Action Cloudy or discoloured electrolyte may be caused by overcharging or vibration. This can cause a high self discharge of the battery. Correct the cause then replace the battery.

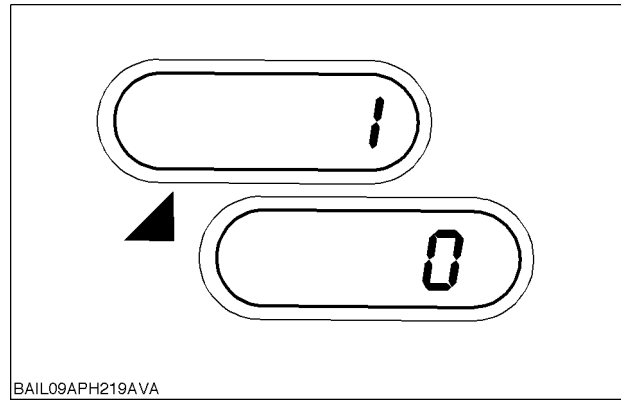

BAIL09APH219AVA 27

To save the desired option, depress and hold the "h" or "m" button until the instrument cluster bleeps, indicating that the selection has been saved.

Press the "dimming" button to continue navigating the "HH" menus.

Channel 3 - Set Fly-shift Speed Threshold (24x24 Transmission)

This option is used to select the fly-shift threshold in km/h.

Select channel 3 using the "h" and "m" buttons.

Using the "h" or "m" buttons select between 1, 5, 10, and 40.

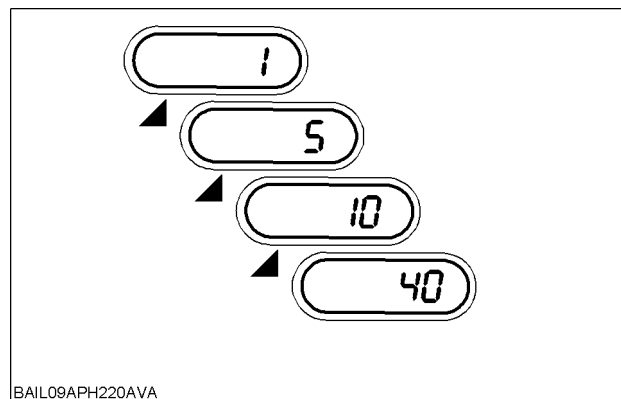

BAIL09APH220AVA 28

Selecting 40 disables the fly-shift engagement.

To save the desired option, depress and hold the "h" or "m" button until the instrument cluster bleeps, indicating that the selection has been saved.

Press the "dimming" button to continue navigating the "HH" menus.

Channel 4 - Driver Selectable Shuttle Modes (16x16 Transmission)

This channel is used to select memory shuttle.

Select channel 4 using the "h" and "m" buttons.

The options available are:
 "Yes" - Memory shuttle enabled.
 "no" - Memory shuttle disabled.

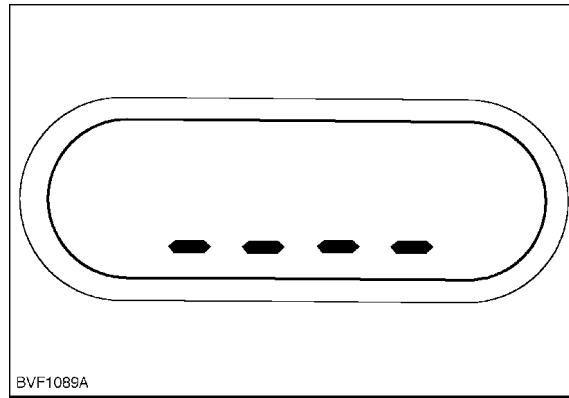

BVF1089A

BVF1089A 86

The lower central display will display "F", if a fault code is stored in the selected sub-system.

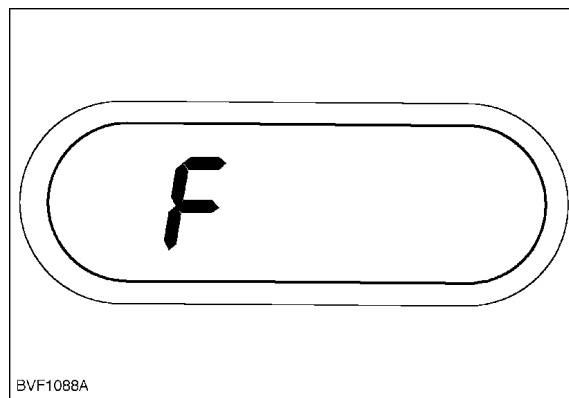

BVF1088A

BVF1088A 87

The lower central display will automatically cycle through as the example:

2024 Fault code

01 Hour of first occurrence

19 Hour of last occurrence

19 Number of occurrences of the fault

Depress the "h" or "m" key to change to the next fault code in the list.

The lower central display will display " _ _ _ " at the end of the list.

Depress the "dimming" key to continue navigating through the "HH" menus.

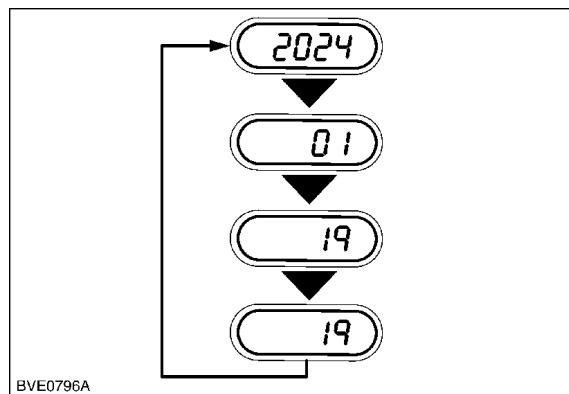

BVE0796A

BVE0796A 88

HC - CLEAR STORED FAULT CODES

HC Menu Screen Select Diagram

HC - CLEAR STORED FAULT CODES

HC Menu Screen Select Diagram

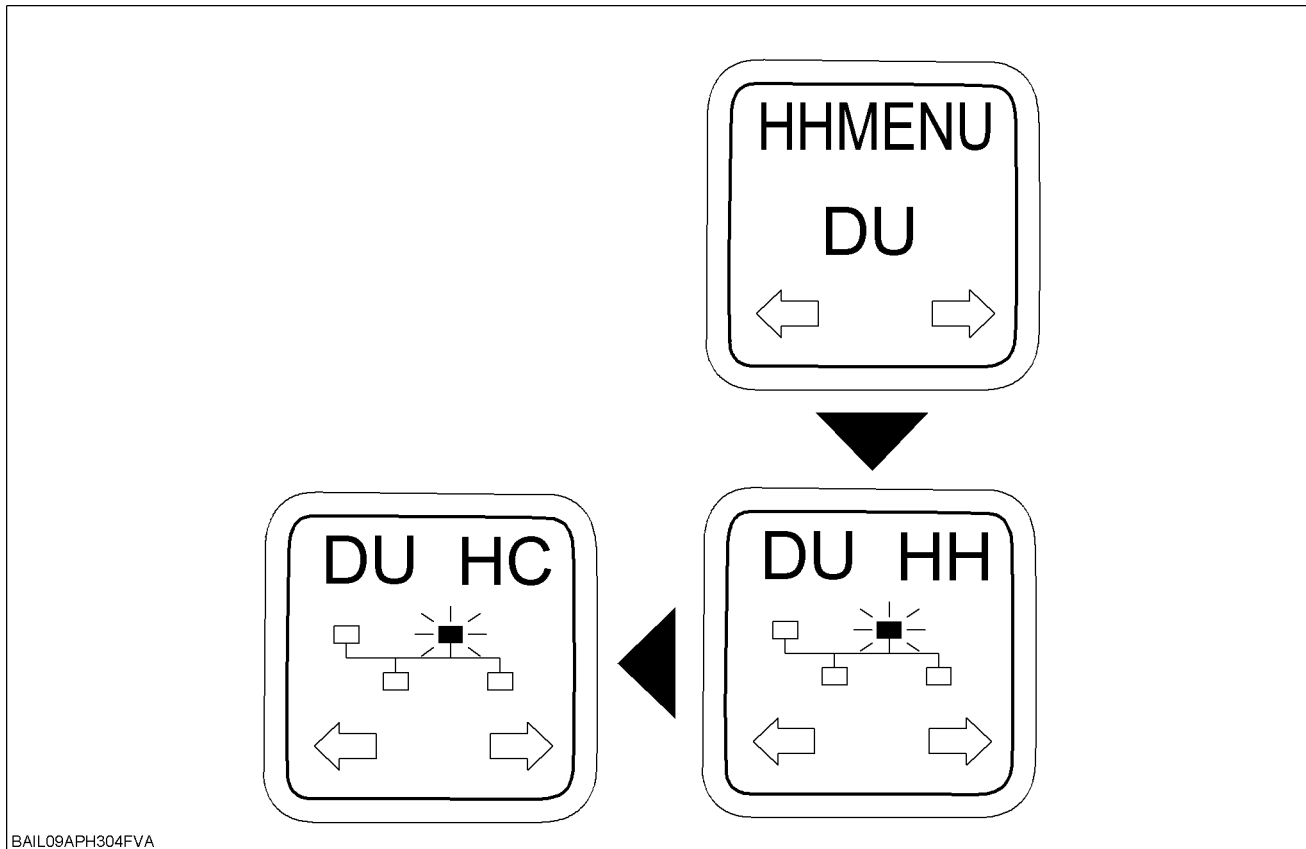

BAIL09APH304FVA

BAIS09APH304FVA 49

NOTE: Always make a note of the fault codes stored, before clearing.

Select the HC menu by depressing the "dimming" key.

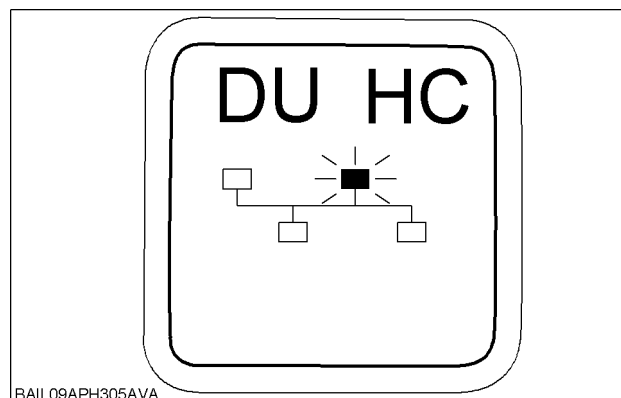

BAIL09APH305AVA

BAIS09APH305AVA 50

The lower central display will display "F CL".

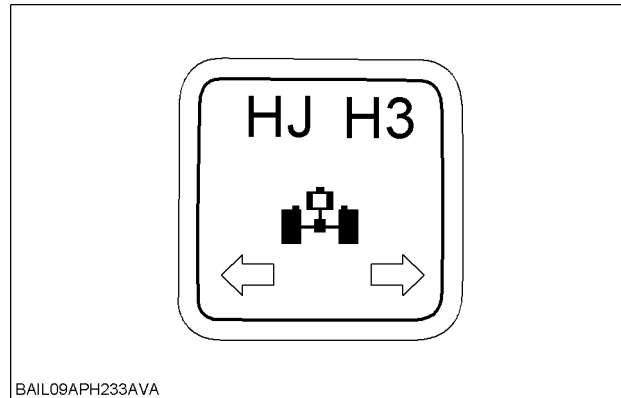

BAIL09APH233AVA

BAIL09APH233AVA 6

NOTE: The default setting is heavy duty rear axle.

Scroll through the available options using the "h" or "m" button.

Depress and hold the "h" or "m" button to store the selection, an audible tone will be heard to confirm the selection. Depress the "dimming" button to continue navigating through the "HH" menus.

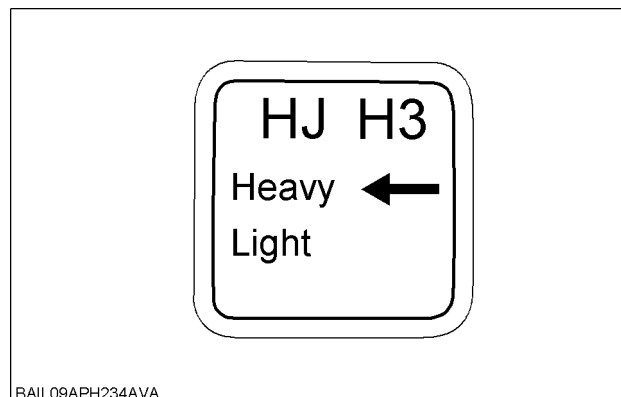

BAIL09APH234AVA

BAIL09APH234AVA 7

AIR BRAKE OPTIONS

Select the air brake sub-system by depressing the "dimming" button.

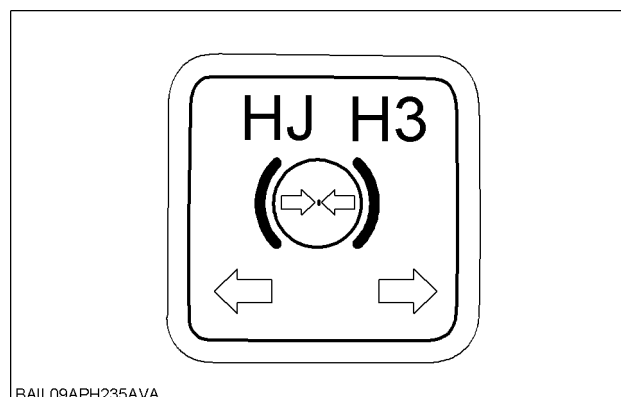

BAIL09APH235AVA

BAIL09APH235AVA 8

NOTE: The default setting is "No" without air brakes.

Scroll through the available options using the "h" or "m" button.

Depress and hold the "h" or "m" button to store the selection, an audible tone will be heard to confirm the selection. Depress the "dimming" button to continue navigating through the "HH" menus.

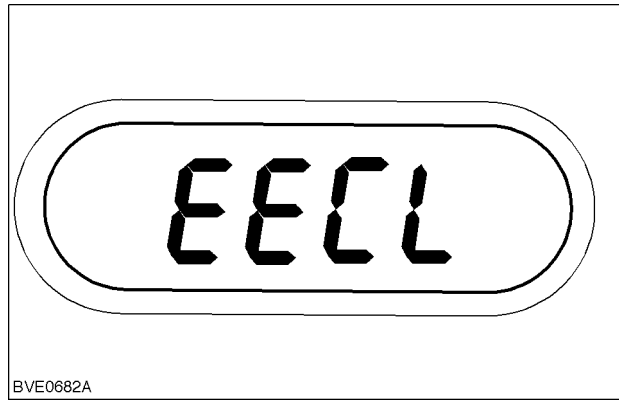

BVE0682A 14

Depress and hold the "m" button to confirm the resetting of the EEPROM.
The lower central display will countdown from 05 to 01, then "EE" will be displayed to indicate the EEPROM has been cleared.
Turn the keystore OFF.

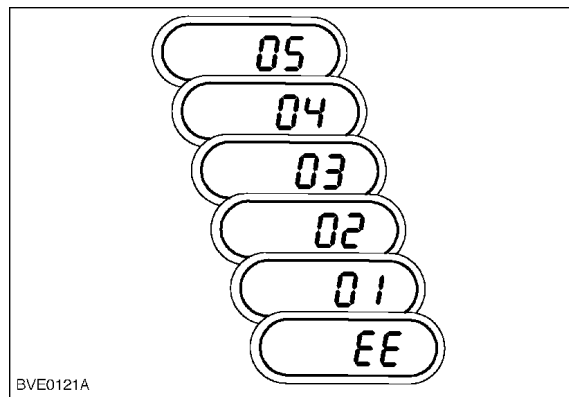

BVE0121A 15

24x24 Transmission Calibration 'U' Error Codes

Code	Description	Possible Failure
U37	Synchroniser potentiometer signal is out of range for reverse	1) Synchroniser potentiometer has been painted through production 2) Synchroniser potentiometer / connector has been damaged 3) Synchroniser assembly. is very tight / sticky. Note: Use the voltmeter to check the Synchroniser potentiometer signal. If OK then repeat calibration to free up synchroniser.
U38	Synchroniser potentiometer signal is out of range for forward	1) Synchroniser potentiometer has been painted through production 2) Synchroniser potentiometer / connector has been damaged. 3) Synchroniser assembly. is very tight / sticky. Note: Use the voltmeter to check the Synchroniser potentiometer signal. If OK then repeat calibration to free up synchroniser.
U39	Synchroniser did not move toward reverse, even at maximum pressure	1) The forward & reverse solenoid connectors need to be swapped 2) The reverse solenoid is faulty 3) No oil Pressure to shift the synchroniser. 4) Synchroniser potentiometer has been painted through production 5) Synchroniser potentiometer / connector has been damaged Note: Remove the Transmission top cover and watch the synchroniser movement to help detect failure or use H9 and look at the potentiometer signal in voltmeter.
U40	Synchroniser did not move toward forward, even at maximum pressure	1) The forward & reverse solenoid connectors need to be swapped 2) The forward solenoid is faulty 3) No oil Pressure to shift the synchroniser. 4) Synchroniser potentiometer has been painted through production 5) Synchroniser potentiometer / connector has been damaged Note: Remove the Transmission top cover and watch the synchroniser movement to help detect failure or use H9 and look at the potentiometer signal in voltmeter.
U82	No 12VD – No power for High and Low clutch solenoids	1) Check module fuses 2) Check battery voltage 3) Check Module connection

HYDRAULIC - PNEUMATIC - ELECTRICAL - ELECTRONIC SYSTEMS - FAULT CODES

Reference	Description	Controller
4120	Rear Remote No.2 Spool Movement Too Low	
4121	Rear Remote No.2 Spool Movement Too High	
4122	Rear Remote No.2 Float Position Not Reached	
4123	Rear Remote No.2 Manually Operated	
4124	Rear Remote No.2 Driver Faulty	
4125	Rear Remote No.2 Potentiometer Faulty	
4126	Rear Remote No.2 Unable To Reach Neutral	
4127	Rear Remote No.2 Spool Not In Neutral At Key On.	
4128	Rear Remote No.3 No Control Message Received	
4129	Rear Remote No.3 Control Message Not Plausible	
4130	Rear Remote No.3 EEPROM Error	
4131	Rear Remote No.3 Switched To Failsafe	
4132	Rear Remote No.3 Under Voltage	
4133	Rear Remote No.3 Over Voltage	
4134	Rear Remote No.3 Spool Movement Too Low	
4135	Rear Remote No.3 Spool Movement Too High	
4136	Rear Remote No.3 Float Position Not Reached	
4137	Rear Remote No.3 Manually Operated	
4138	Rear Remote No.3 Driver Faulty	
4139	Rear Remote No.3 Potentiometer Faulty	
4140	Rear Remote No.3 Unable To Reach Neutral	
4141	Rear Remote No.3 Spool Not In Neutral At Key On	
4142	Rear Remote No.4 No Control Message Received	
4143	Rear Remote No.4 Control Message Not Plausible	
4144	Rear Remote No.4 EEPROM Error	
4145	Rear Remote No.4 Switched To Failsafe	
4146	Rear Remote No.4 Under Voltage	
4147	Rear Remote No.4 Over Voltage	
4148	Rear Remote No.4 Spool Movement Too Low	
4149	Rear Remote No.4 Spool Movement Too High	
4150	Rear Remote No.4 Float Position Not Reached	
4151	Rear Remote No.4 Manually Operated	
4152	Rear Remote No.4 Driver Faulty	

Crankshaft - Dimension

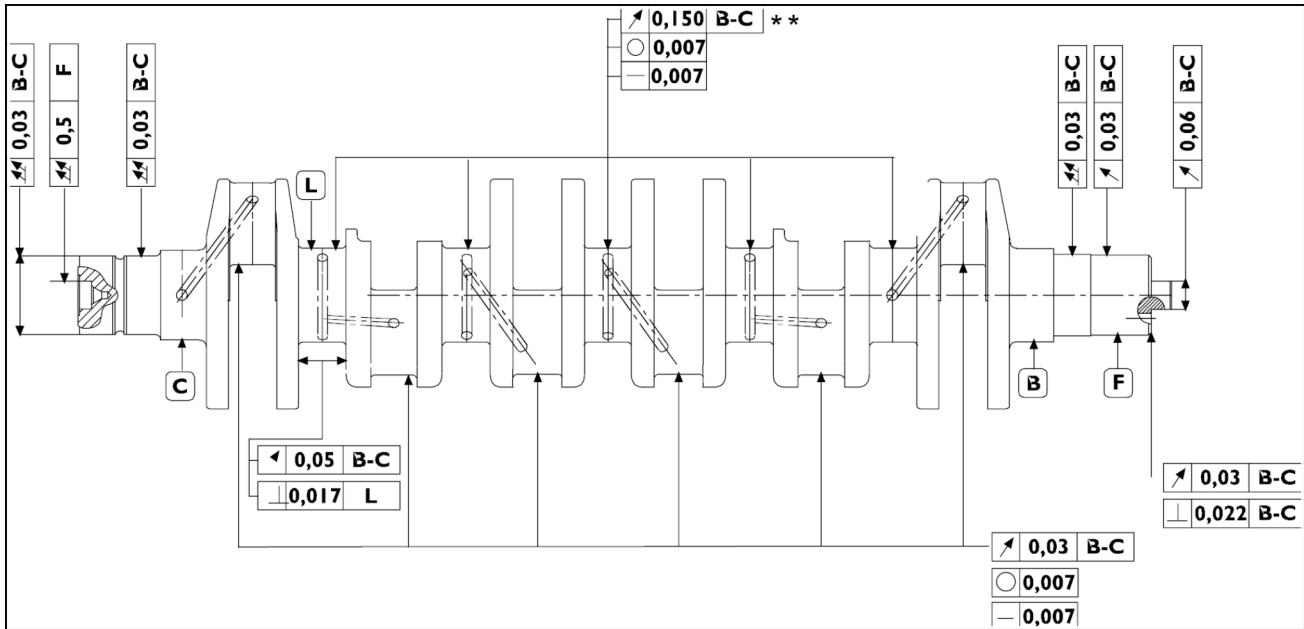

BAIL07APH420FMA 1

MAIN CRANKSHAFT TOLERANCES

TOLERANCES	CHARACTERISTIC SUBJECT OF TOLERANCE	GRAPHIC SYMBOL
SHAPE	Circularity	○
	Cylindricity	/O/
ORIENTATION	Parallelism	//
	Perpendicularity	⊥
	Straightness	—
POSITION	Concentricity or coaxiality	⊙
OSCILLATION	Circular oscillation	↗
	Total oscillation	**
	Taper	↘
CLASS OF IMPORTANCE ASSIGNED TO PRODUCT CHARACTERISTICS	GRAPHIC SYMBOL	
CRITICAL	●	
IMPORTANT	◐	
SECONDARY	△	

CLICK HERE TO **DOWNLOAD** THE COMPLETE MANUAL

- Thank you very much for reading the preview of the manual.
- You can download the complete manual from: www.heydownloads.com by clicking the link below



- Please note: If there is no response to CLICKING the link, please download this PDF first and then click on it.

CLICK HERE TO **DOWNLOAD** THE COMPLETE MANUAL

30. Using a suitable chain, connect the engine to a hoist. Remove the engine to transmission retaining bolts and remove the engine.

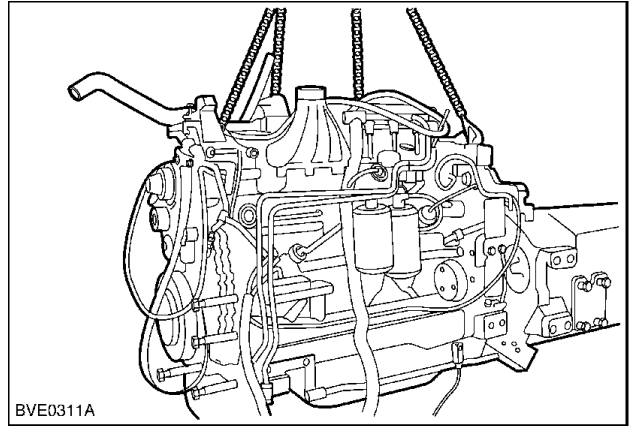

BVE0311A 29

Next operation:
ENGINE - Install (B.10.A)

23. Remove the nuts (1) and detach the high-pressure pump (2) together with the feed pump (3).

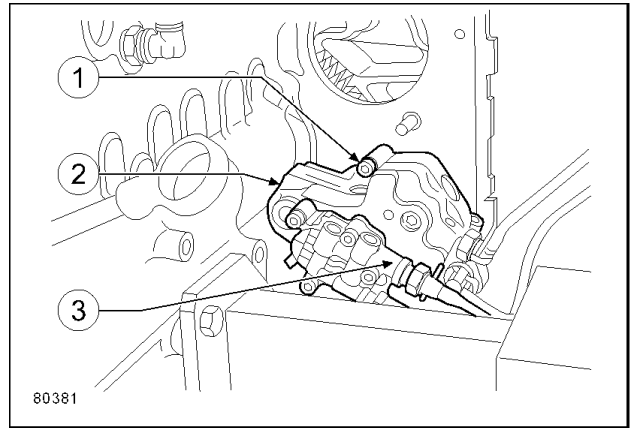

80381 19

24. Install the engine locking tool, **380000988**, (1), Loosen the screws fixing the flywheel to the crankshaft.

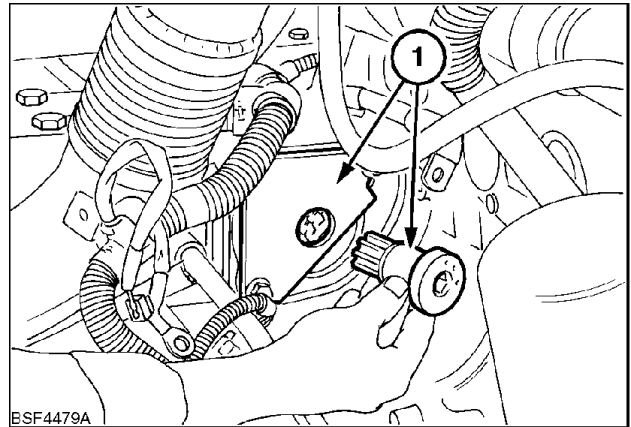

BSF4479A 20

25. Unscrew the bolts (1), remove the pulley (2), spacer (3) and pulley (4). The engine flywheel locking tool can help with disassembly of the damper flywheel (2) fitted on the pulley (4).

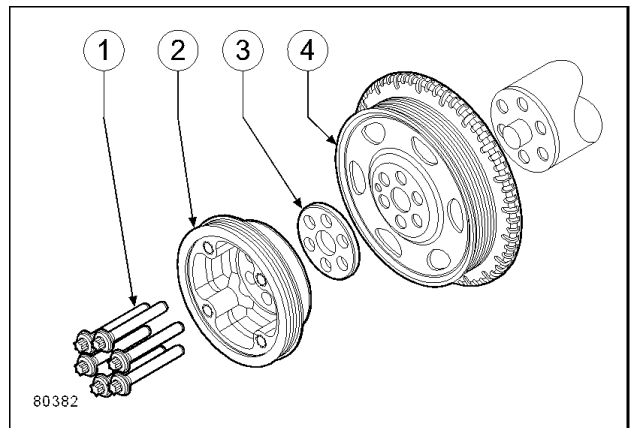

80382 21

Valve drive Camshaft - Measure

NOTE: The support journal surfaces on the shaft and cams must be finely honed; if there are any signs of seizing or scoring, replace the camshaft and relevant bushings.

1. Set the shaft on a support and, using a dial gauge with a **1/100 mm** scale placed on the central support, check that the alignment error is no greater than **0.04 mm (0.0016 in)**; change the shaft if it is. Check the diameter of the supporting pins of the camshaft (**2**) with the micrometer (**1**) on two perpendicular axis. (Refer to **Valve drive Camshaft - Dimension (B.10.A)**, and **Cylinder block - Overhaul (B.10.A)**).

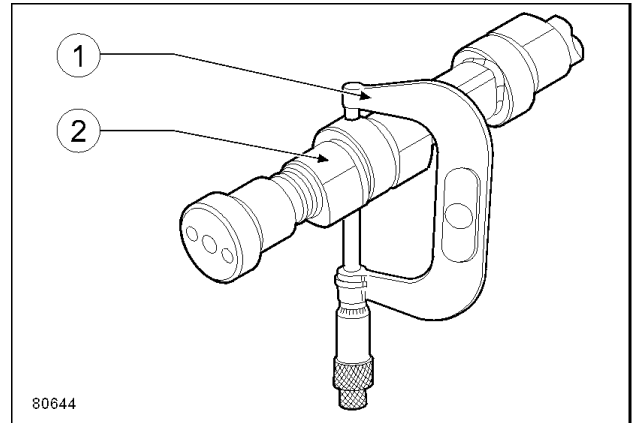

80644_164 1

2. Check cam lift.
 Exhaust cam = **6.045 mm (0.2380 in)**
 Inlet cam = **7.582 mm (0.2985 in)**
 If the camshaft does not meet these specifications

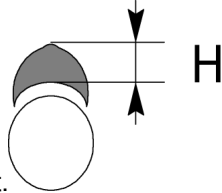

replace the camshaft.

Contents

ENGINE AND PTO IN - B

FUEL AND INJECTION SYSTEM - 20.A

SERVICE

Fuel injection pump

Remove Delphi Rotary Fuel Pump 3

Install 7

Index

ENGINE AND PTO IN - B

EXHAUST SYSTEM - 40.A

Exhaust manifold - Install	6
Exhaust manifold - Remove	5
Exhaust manifold - Tighten - Sequence.	7
Silencer - Install	4
Silencer - Remove	3

19. Install the charge air cooler outlet pipe and connect the air cooler to intake manifold hose.

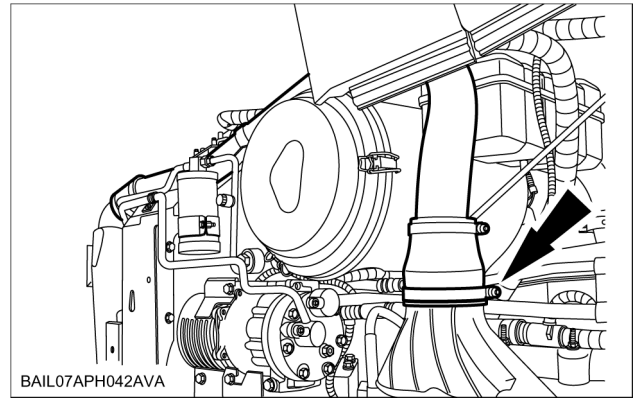

BAIL07APH042AVA 19

20. Connect the charge air cooler outlet hose (1), and retaining clamp (3). Connect the receiver/drier retaining bracket (2) to the radiator housing.

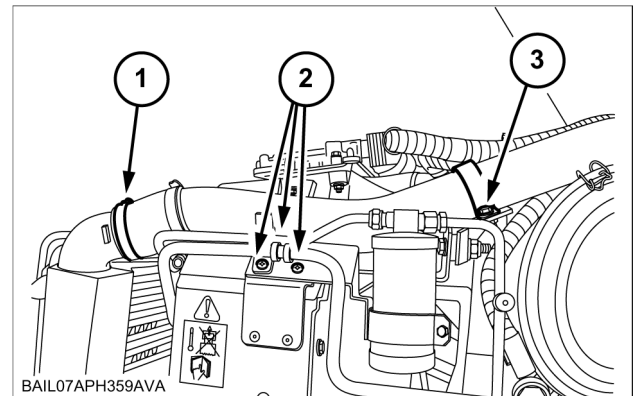

BAIL07APH359AVA 20

Next operation:

Fill the engine coolant system, for further information refer to **ENGINE COOLANT SYSTEM - Filling (B.50.A)**



PRINTED IN FRANCE

© 2010 CNH GLOBAL N.V.

All rights reserved. No part of the text or illustrations of this publication may be reproduced.

NEW HOLLAND policy is one of continuous improvement and the right to change prices, specification or equipment at any time without notices is reserved.

All data given in this publication is subject to production variations. Dimensions and weight are approximate only and the illustrations do not necessarily show products in standard condition. For exact information about any particular product, please consult your NEW HOLLAND Dealer.

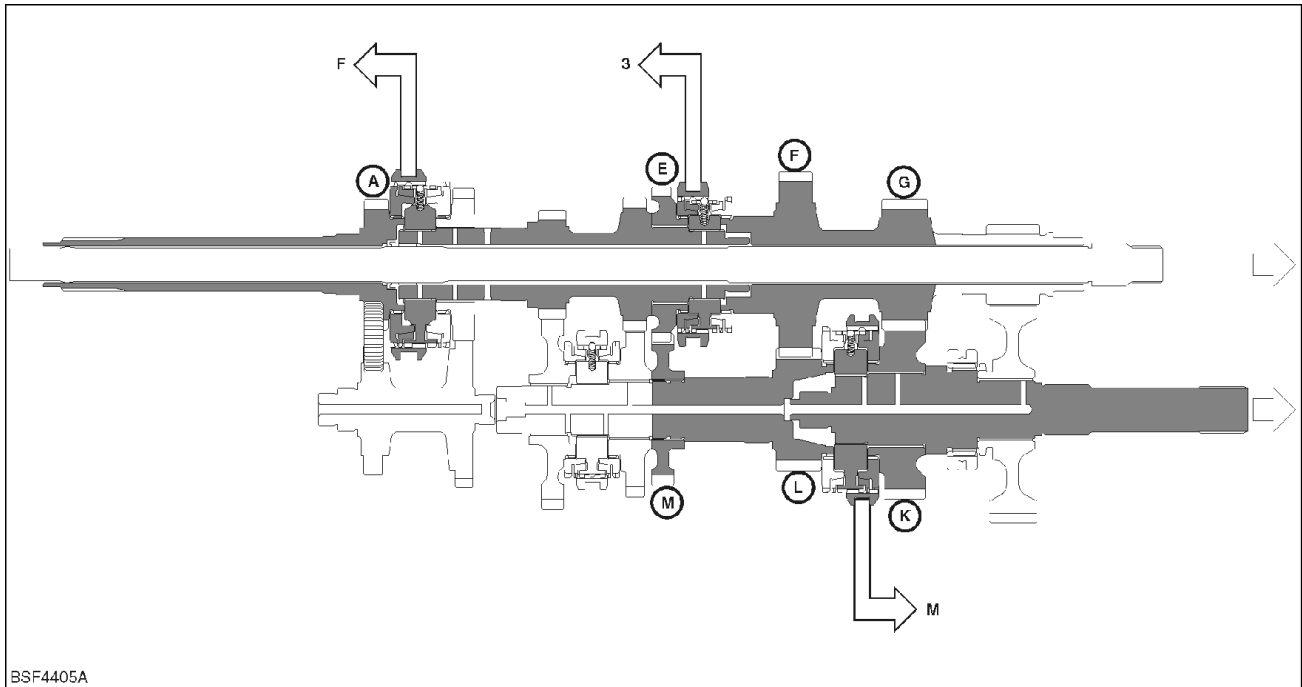

BSF4405A

BSF4405A 7

Power Flows - 7th Gear

Input shaft - gear A - forward/reverse synchronizer - 3/4 synchronizer - gears E-M-L-F-G-K - high/medium synchronizer - output shaft.

Gear Lever Positions

- Shuttle lever in forward, main shift lever in 3rd gear and range lever in medium range.

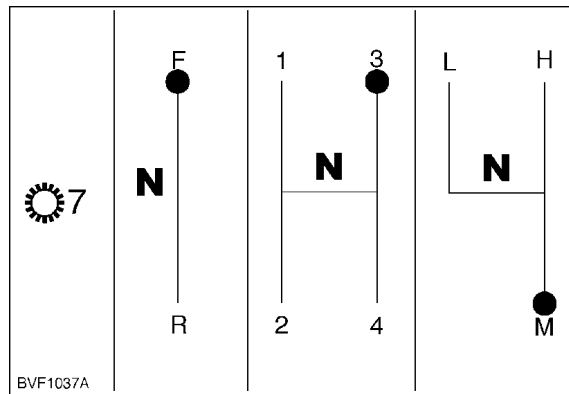

BVF1037A

BVF1037A 8

TRANSMISSION Mechanical - Assemble

T6030, T6050, T6010, T6020

Prior operation:
TRANSMISSION Mechanical - Disassemble (C.20.B)

⚠ WARNING ⚠

Handle all parts carefully. Do not put your hands or fingers between parts. Wear suitable safety clothing - safety goggles, gloves and shoes.

B026

⚠ WARNING ⚠

Lift and handle all heavy components using lifting equipment of appropriate lifting capacity. Make sure that units or parts are supported by suitable slings or hooks. Make sure that no-one is in the vicinity of the load to be lifted. Failure to comply could result in serious injury or death.

B012

Middle Section Installation

1. Install the 3/4 synchronizer and 3rd gear drive assembly (1).

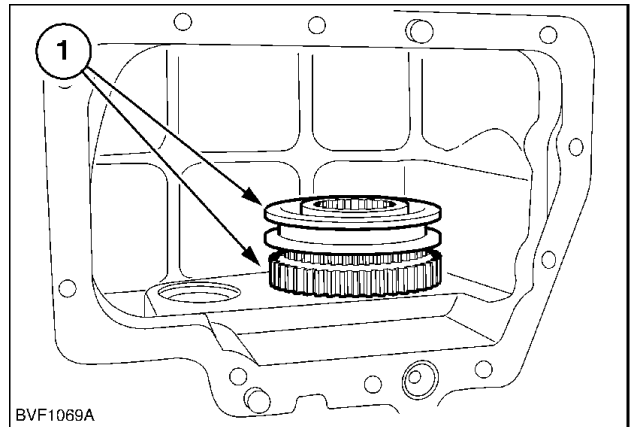

BVF1069A_295 1

2. Install the main shaft (1) through the bell-housing.

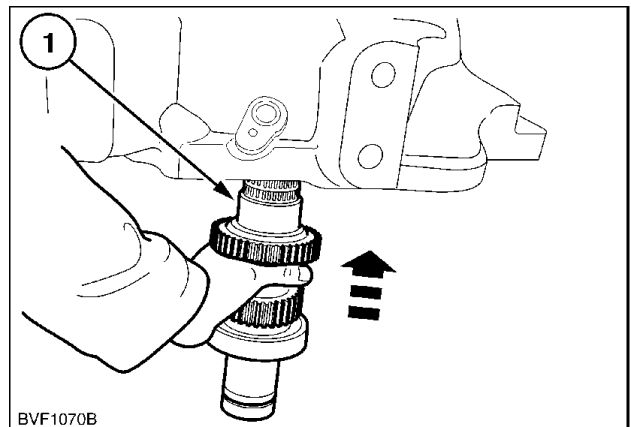

BVF1070B_306 2

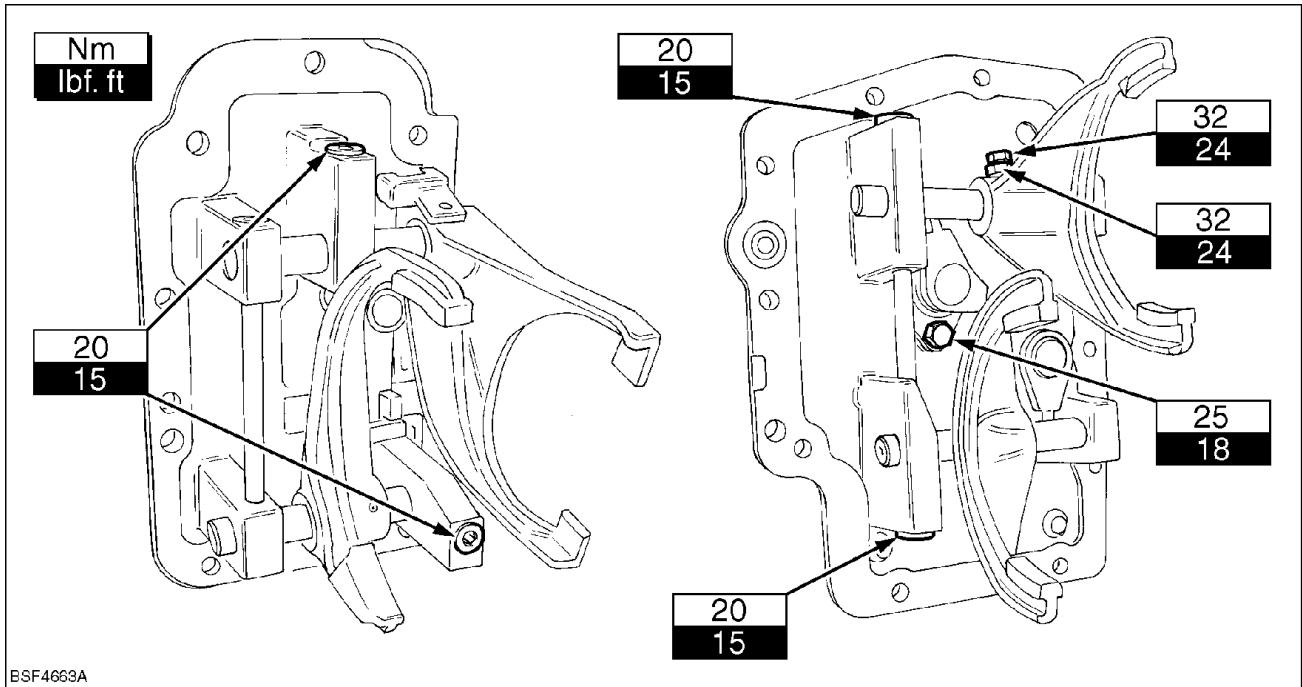

BSF4663A 2

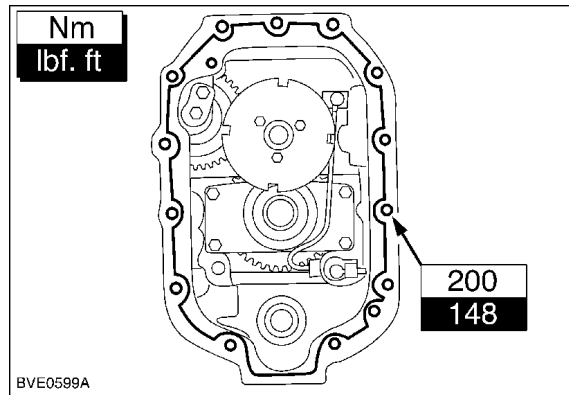

BVE0599A_49 3

TRANSMISSION Power Shuttle - Special tools

T6030, T6050, T6070, T6010, T6020

⚠ CAUTION ⚠

The operations described in this section can only be carried out with the **ESSENTIAL** tools indicated by an (X). To work safely and efficiently and obtain the best results, it is also necessary to use the recommended specific tools listed below and certain other tools, which are to be made according to the drawings included in this manual.

B008

	Tool No.	Description	Alternative previous No.
	380000569	Tractor splitting kit	297471
X	380001116	Transmission lifting eyebolt	-
X	380000291	Clutch piston return spring compressor	295021

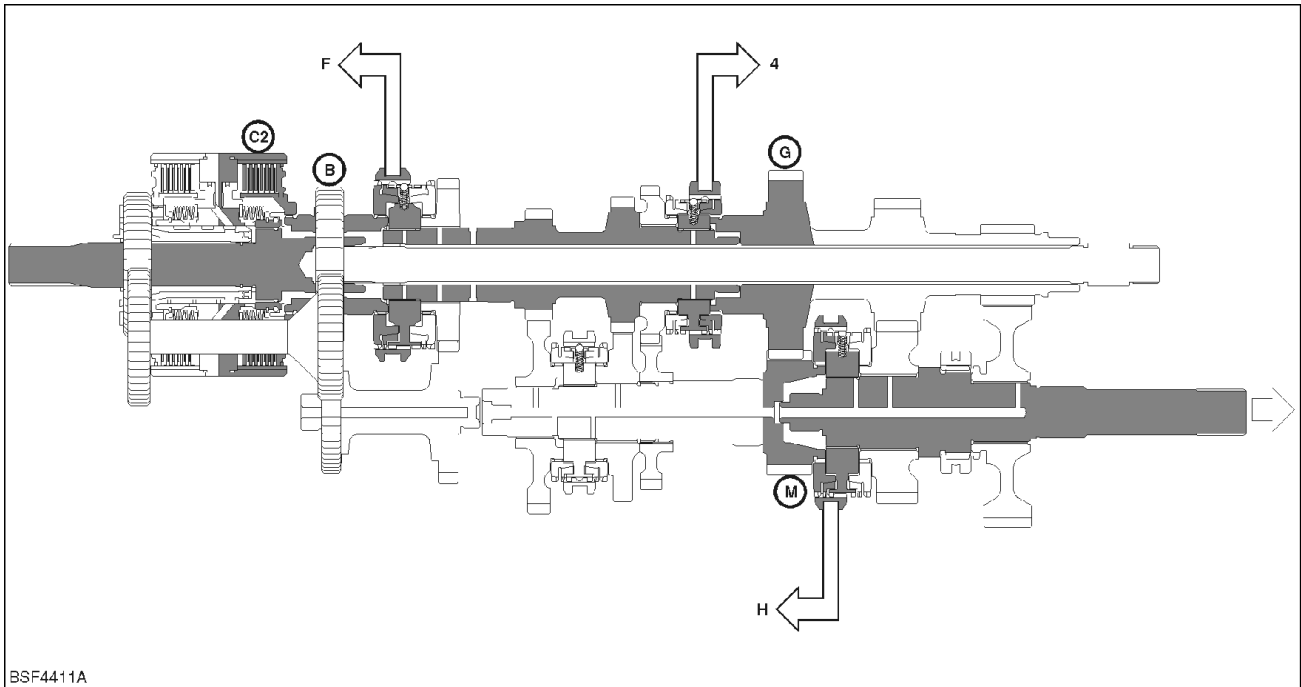

BSF4411A 9

Power Flows - 24th Gear

Input shaft - C2 - gear B - forward/reverse synchronizer - 3/4 synchronizer - gear G-M - high/medium synchronizer - output shaft.

Gear Lever Positions

- Shuttle lever in forward, main shift lever in 4th gear and range lever in high range.
- C2 (direct drive) clutch engaged.

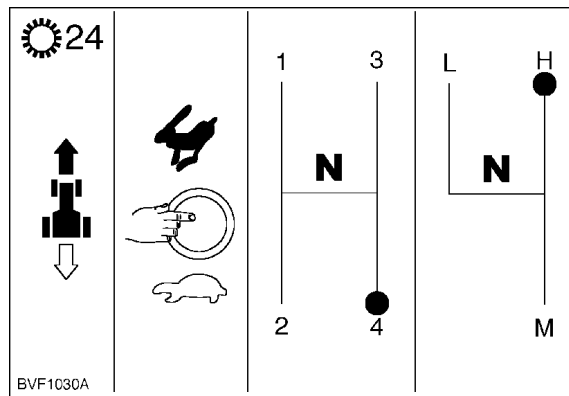

BVF1030A 10

Rear Section Installation

11. Install the range cluster gear shaft (1).

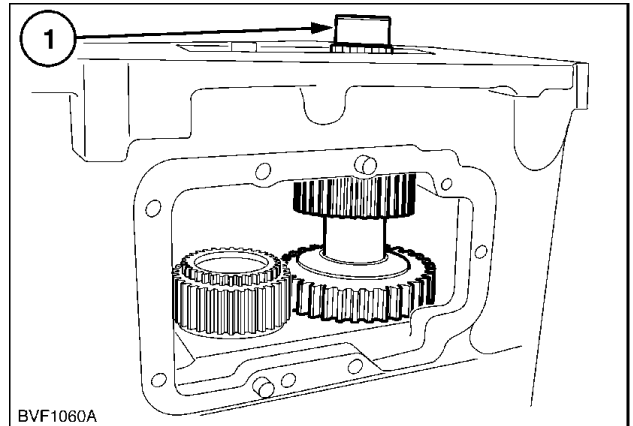

BVF1060A 11

12. Install the high/medium synchronizer rings (1).

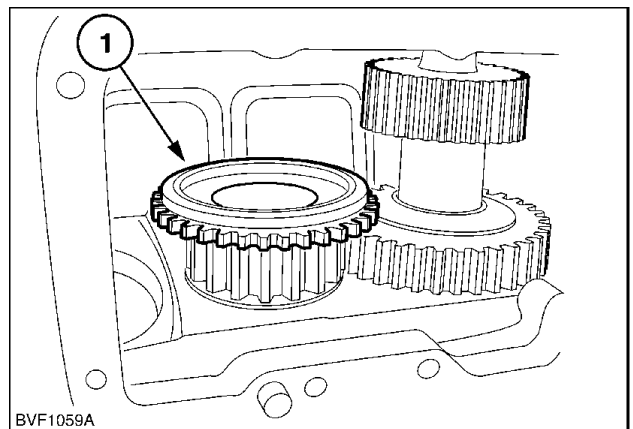

BVF1059A 12

13. Install the output shaft assembly (1).

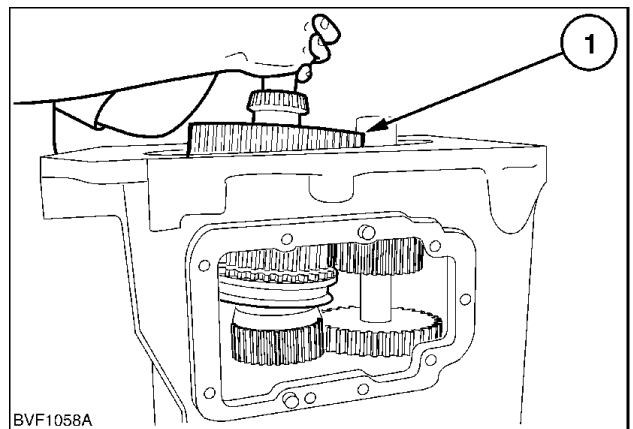

BVF1058A 13

12. Remove the C1/C2 clutch assembly (1).

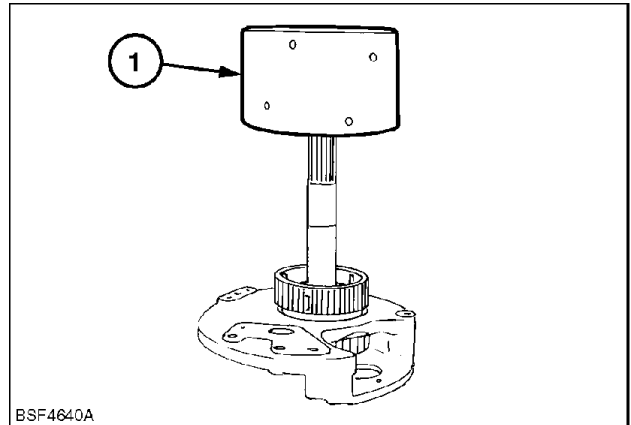

BSF4640A 12

13. Remove the C2 clutch hub (1).

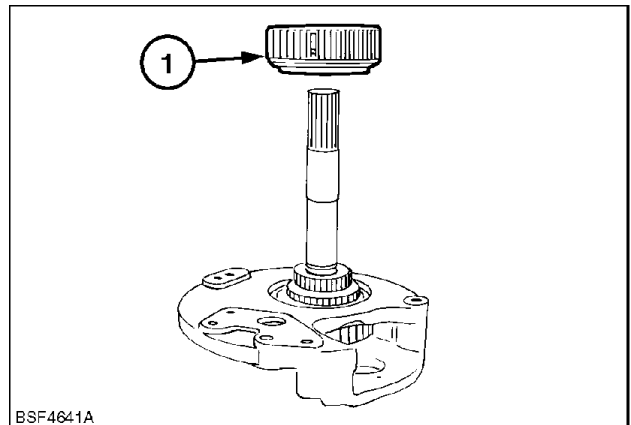

BSF4641A 13

14. Remove the input driveshaft (1).

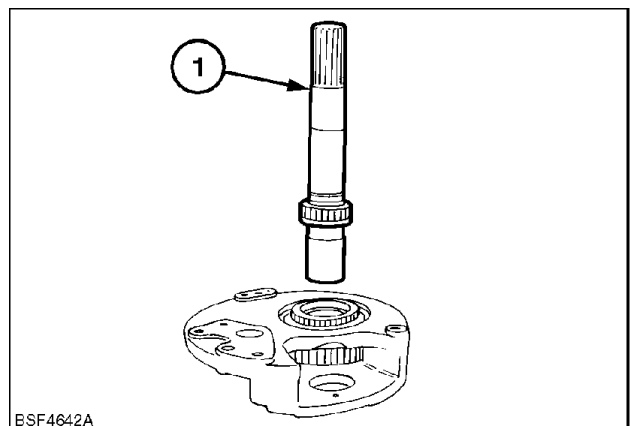

BSF4642A 14

15. Rotate the back plate **180 °**.
Using suitable snap ring pliers, remove the C1 clutch drive gear retaining snap ring (1).

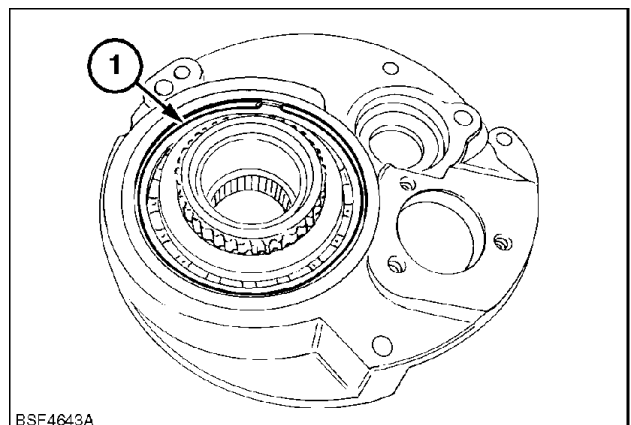

BSF4643A 15

TRANSMISSION Power Shuttle - General specification 8
T6030, T6050, T6070, T6010, T6020
TRANSMISSION Power Shuttle - Install 71
T6030, T6050, T6070, T6010, T6020
TRANSMISSION Power Shuttle - Pressure test 76
T6030, T6050, T6070, T6010, T6020
TRANSMISSION Power Shuttle - Remove 53
T6030, T6050, T6070, T6010, T6020
TRANSMISSION Power Shuttle - Sectional view 20
T6030, T6050, T6070, T6010, T6020
TRANSMISSION Power Shuttle - Special tools 6
T6030, T6050, T6070, T6010, T6020
TRANSMISSION Power Shuttle - Static description 10
T6030, T6050, T6070, T6010, T6020
TRANSMISSION Power Shuttle - Torque 5
T6030, T6050, T6070, T6010, T6020
TRANSMISSION Power Shuttle - Troubleshooting 123
T6030, T6050, T6070, T6010, T6020

TRANSMISSION Semi-Powershift - Static description

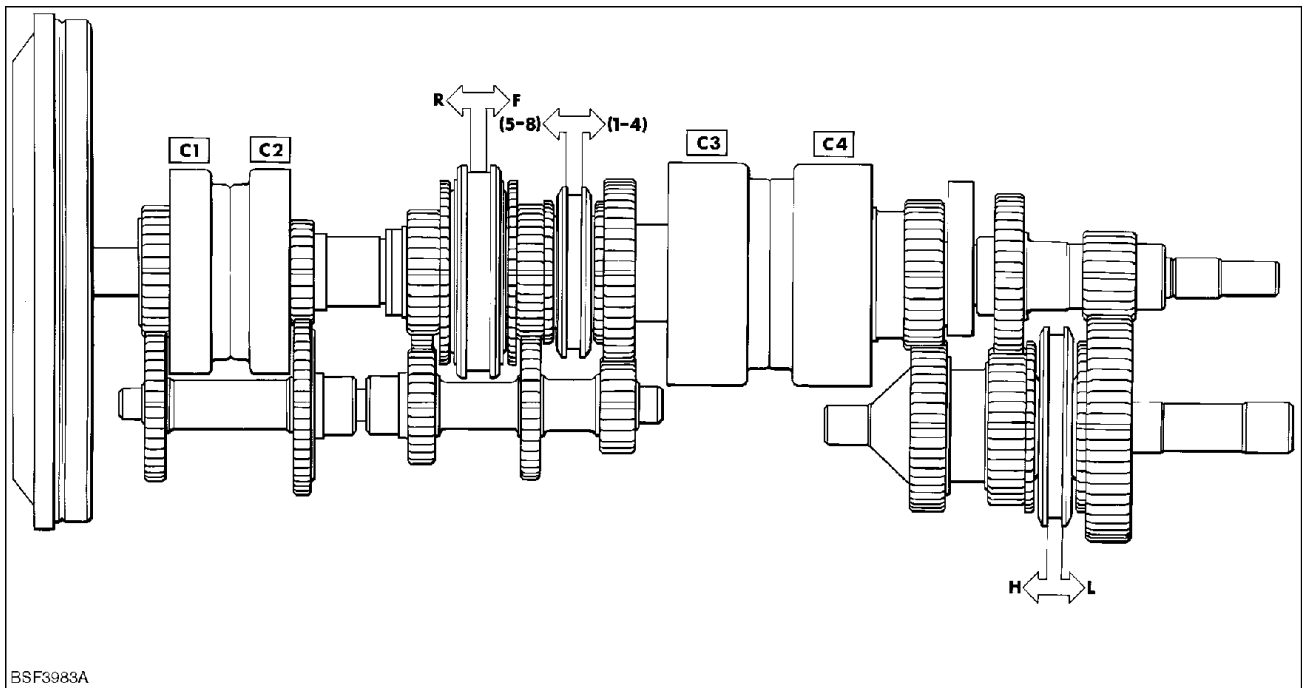

BSF3983A 1

The transmission drive can be split into three sections as follows:

C1 and C2 clutches - located at the front of the transmission to work in conjunction with C3 and C4 to give 4 basic ratios.

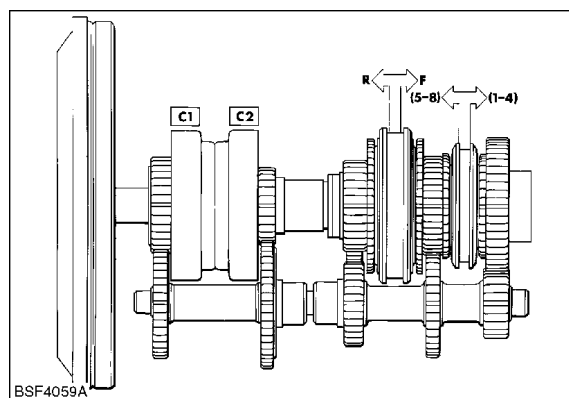

BSF4059A 2

Next operation:

Install the transmission control valve (refer to **Control valve - Overview (C.20.D)**).

Install the transmission top cover (refer to **Cover - Exploded view (C.20.D)**).

8. Using suitable circlip pliers, remove the forward/reverse synchroniser retaining circlip (1).

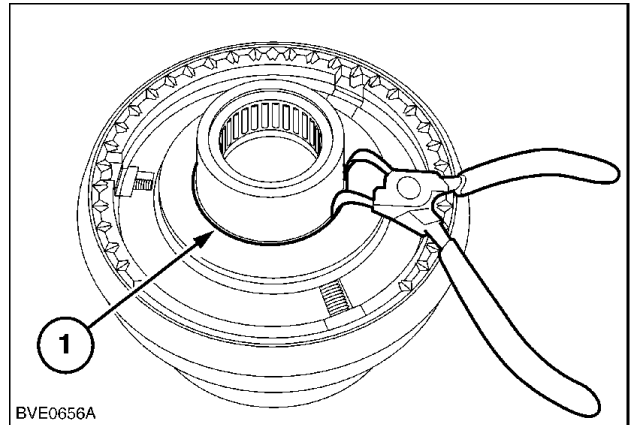

BVE0656A 11

9. Remove the forward/reverse synchroniser (1).

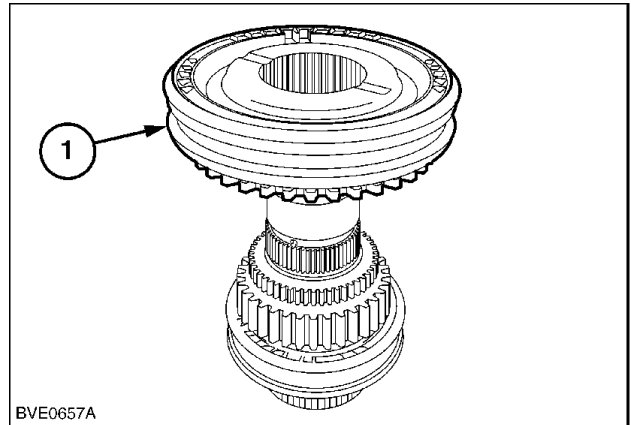

BVE0657A 12

10. Remove the reverse gear (1), needle roller bearing (2), 'D' shaped washer (3) and the circlip (4). Using a suitable hydraulic press, remove the roller bearing (5) from the forward/reverse synchroniser support shaft (6).

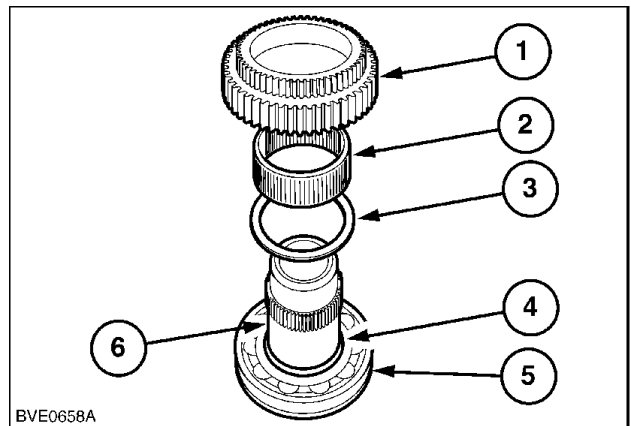

BVE0658A 13

18. The support shaft also contains rubber adaptors (1) and (5), these adaptors join the C1/C2 clutch oil transfer tubes and the front lower shaft lubrication oil supply tube.

1. Rubber Adaptor x 1 (small)
2. Annular Seals
3. Support Shaft
4. 'O' Ring Seal
5. Rubber Adaptors x 4 (large)

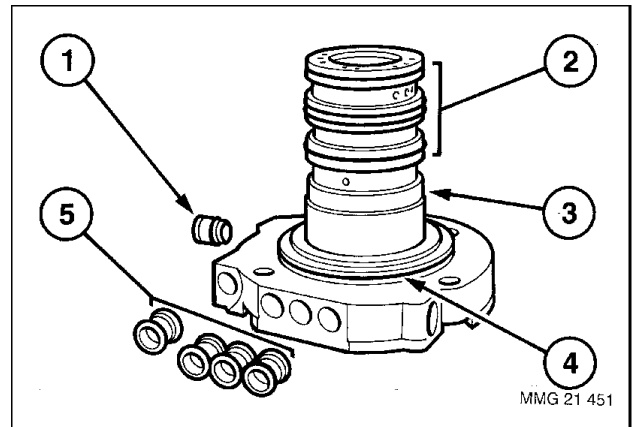

MMG 21 451 8

19. The front cover (3), contains similar rubber adaptors and plugs to the C1/C2 clutch oil transfer tubes and the front lower shaft lubrication oil supply tube. These can be removed and new items installed by removing the plug retaining pins (2) and plugs (1). Install new quad seals as necessary. Inspect all bearings for wear and damage, if necessary remove the bearings from the front lower shaft and install new components as necessary.

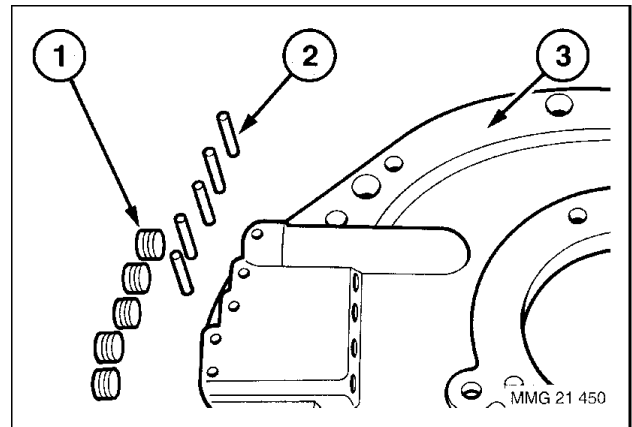

MMG 21 450 9

C1/C2 Clutch Support Manifold Inspection and Assembly

20. Remove the PTO input shaft oil seal (1) from the C1/C2 clutch support manifold (2). Install a new oil seal by gently pressing it into the centre of the support shaft (ensure the oil seal lip is facing inwards towards the transmission). Remove and discard the four annular groove sealing rings (3) and inspect the shaft for wear and damage. Replace parts as necessary. Install new annular groove sealing rings (3) to the support manifold. Ensure the annular groove sealing ring ends are correctly positioned.

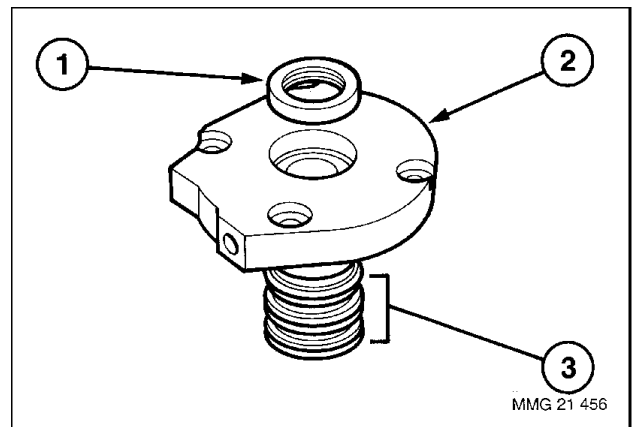

MMG 21 456 10

Cover - Disassemble - Transmission Top Cover.

Prior operation:

Cover - Remove (C.20.D).

1. Remove the two detent assemblies. **Cover - Exploded view (C.20.D).**
2. Remove the two synchronizer position potentiometers, shaft housings and operating shafts.
3. Remove the four PWM solenoid valve assemblies.
4. Remove the 1-4/5-8 shift rail. Remove the circlip and the end cap of the forward/reverse rail. Loosen the shift fork retaining screws. Through the potentiometer housing orifice carefully pry the 1-4/5-8 shift rail from the top cover.
5. Remove the forward/reverse shift rail. Remove the circlip and the end cap of the forward/reverse rail. Loosen the shift fork retaining screws. Through the potentiometer housing orifice carefully lever the forward/reverse shift rail from the top cover.

Next operation:

Cover - Visual inspection (C.20.D).

Control valve - Remove (17th Gear)

Prior operation:

Remove the fuel tank - see **Fuel tank - Remove (B.20.A)**.

1. Disconnect the oil supply pipes (1) and remove the oil supply pipe banjo bolt (2).

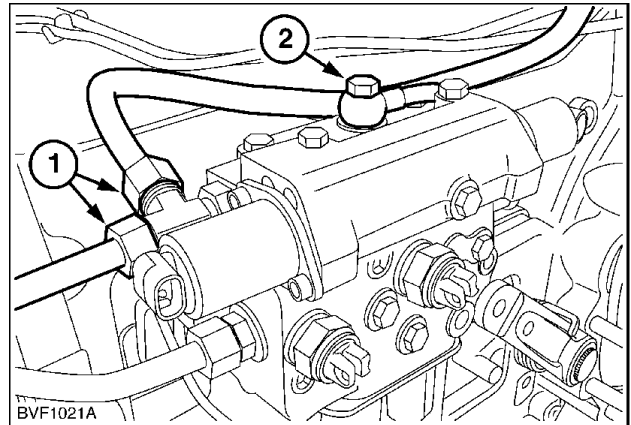

BVF1021A 1

2. Remove the oil supply pipe.

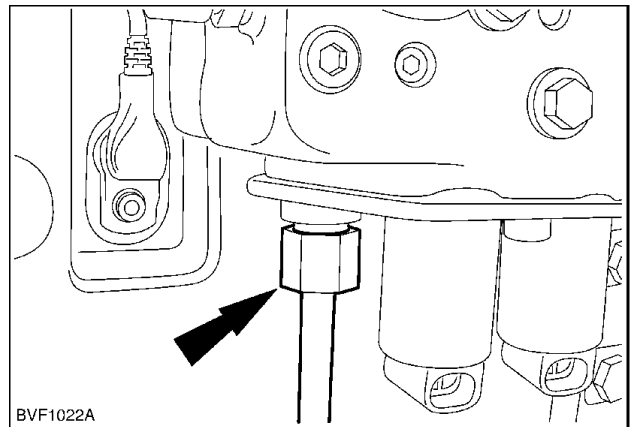

BVF1022A 2

3. Remove the 17th gear solenoid valve block retaining bolts.

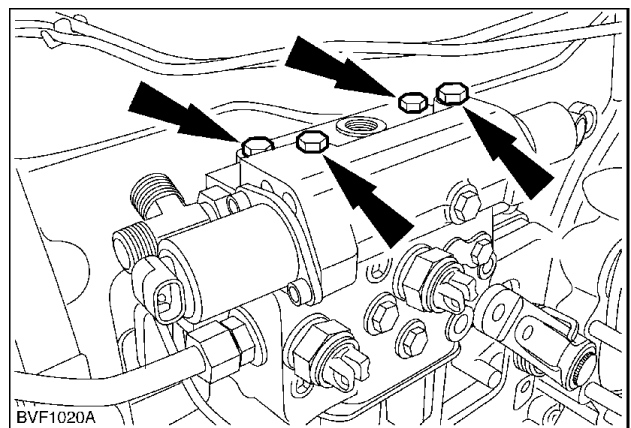

BVF1020A 3

Next operation:

Control valve - Disassemble (17th Gear) (C.30.D)

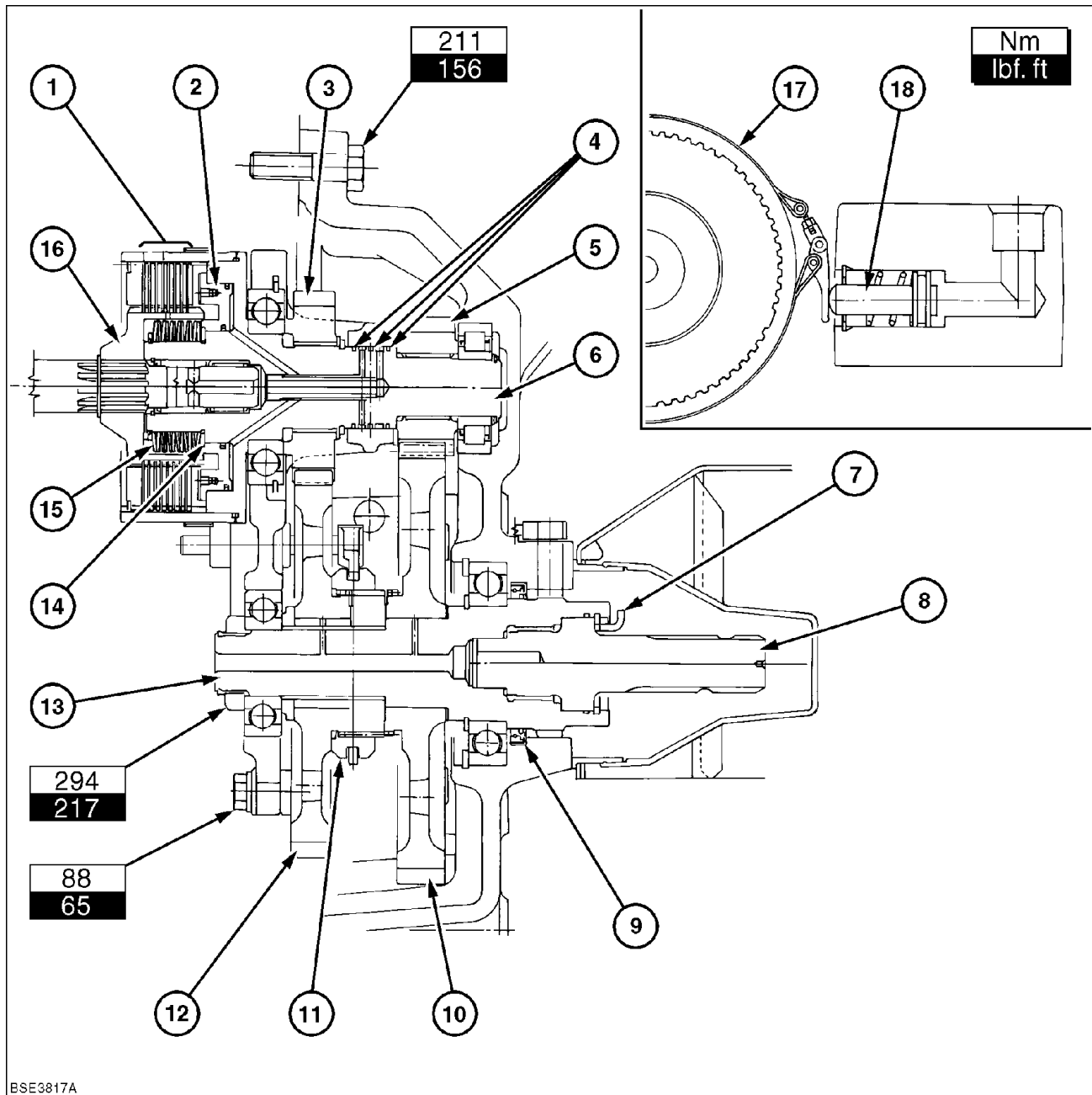

BSE3817A

BSE3817A 2

540 / 1000 RPM PTO Sectional Views and Torque Values

- | | |
|-------------------------------------|--------------------------------|
| 1 Clutch Plates and Separator Discs | 2 Piston |
| 3 1000 RPM Drive Gear | 4 Shaft Seals |
| 5 540 RPM Drive Gear | 6 Clutch Housing Shaft |
| 7 Retaining Ring | 8 PTO Output Shaft |
| 9 Oil Seal | 10 540 RPM Driven Gear |
| 11 540 / 1000 RPM Coupler | 12 1000 RPM Driven Gear |
| 13 Driven Shaft | 14 Washer |
| 15 Belleville Springs | 16 Clutch Hub |
| 17 Brake Band | 18 Brake Piston |

REAR PTO Hydraulic - Special tools

The PTO can be overhauled using proprietary special tools purchased from a good tool retailer. If required the belleville spring compressor tool 50063 can be manufactured to assist in disassembly but this is not essential.

28. Remove the washer (1), **750 RPM** drive gear (2), bearing (3) and **1000 RPM** drive gear (4).

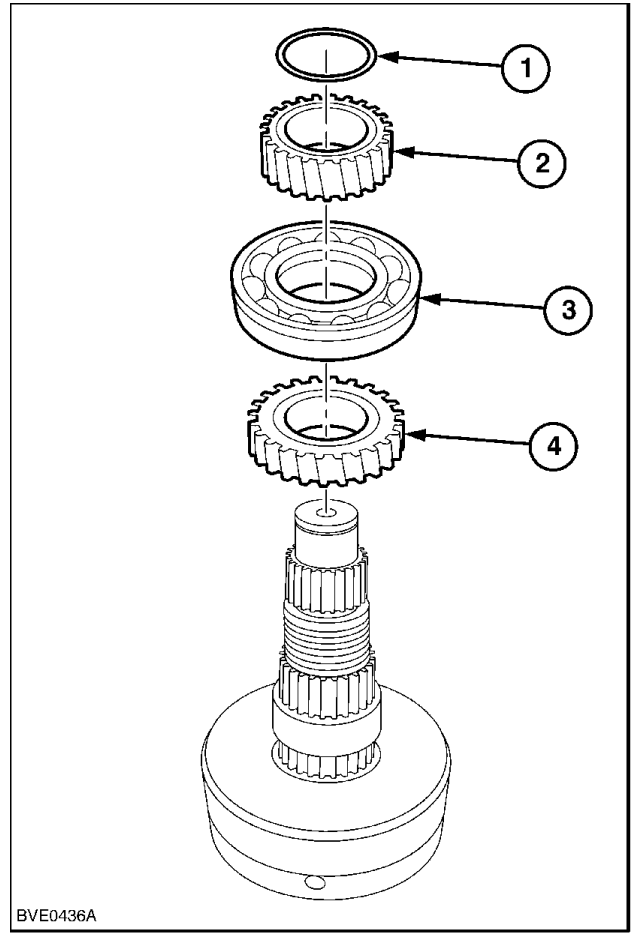

BVE0436A 27

Next operation:
REAR PTO Hydraulic - Assemble (C.40.C)

2. Install the PTO reduction gearbox front cover.

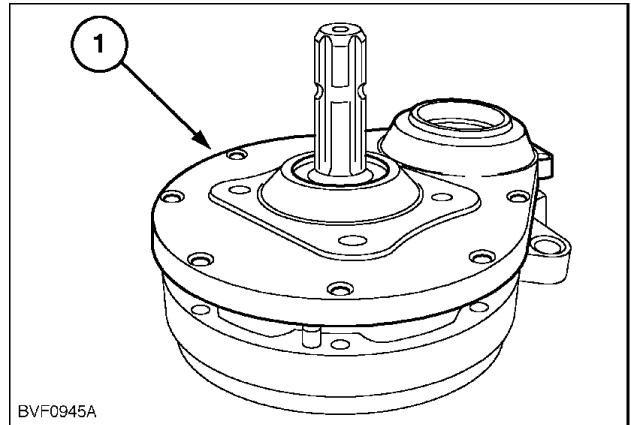

BVF0945A 3

3. Install the PTO reduction gearbox front cover retaining bolts. Tighten to the specified torque value.

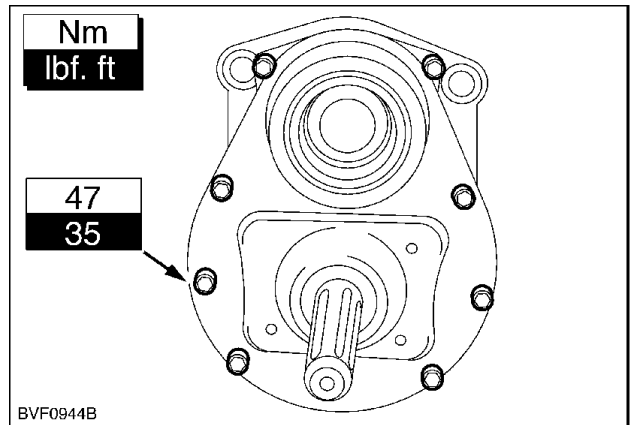

BVF0944B 4

Next operation:
Gearbox - Install (C.42.C)



PRINTED IN FRANCE

© 2010 CNH GLOBAL N.V.

All rights reserved. No part of the text or illustrations of this publication may be reproduced.

NEW HOLLAND policy is one of continuous improvement and the right to change prices, specification or equipment at any time without notices is reserved.

All data given in this publication is subject to production variations. Dimensions and weight are approximate only and the illustrations do not necessarily show products in standard condition. For exact information about any particular product, please consult your NEW HOLLAND Dealer.

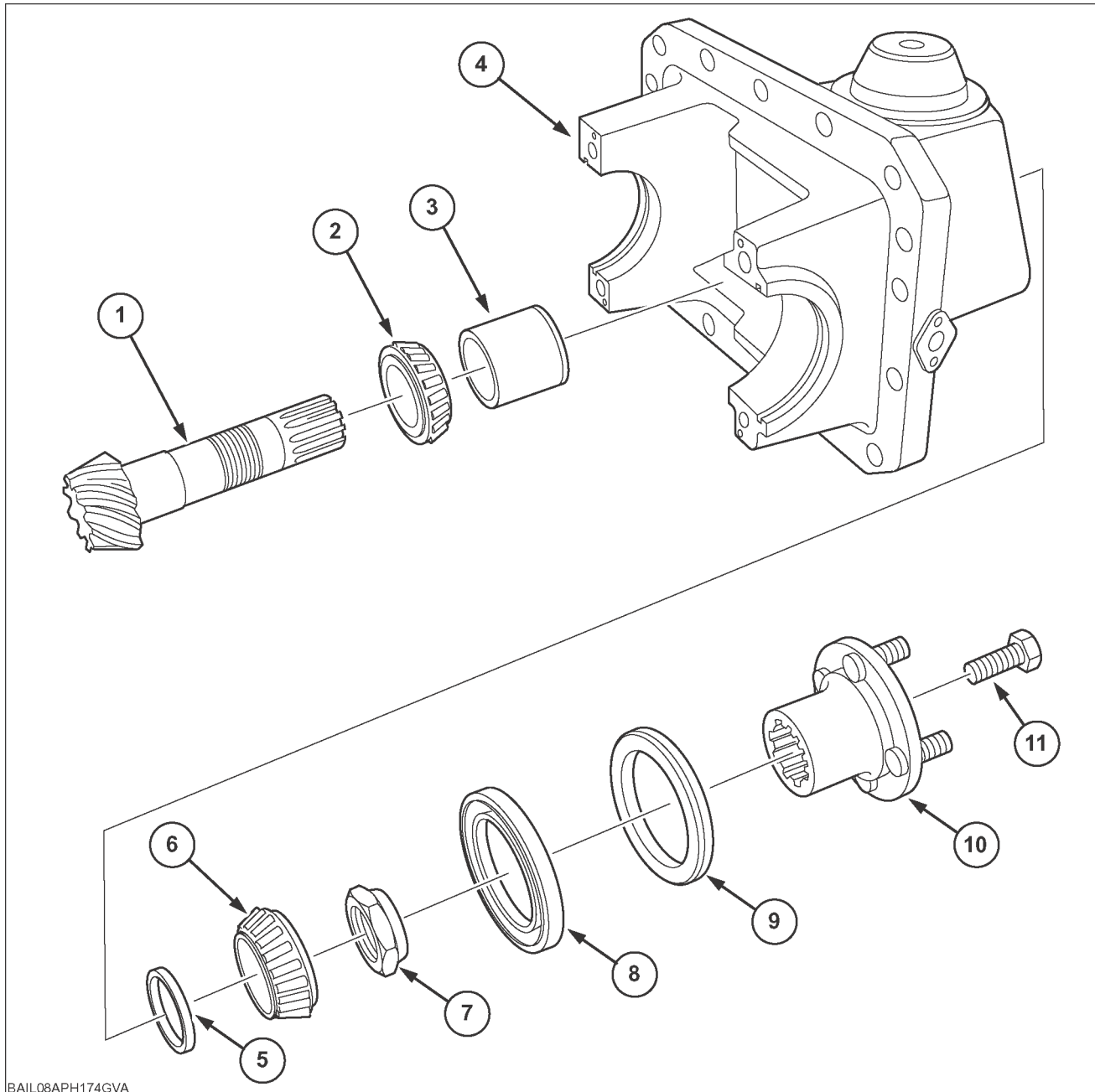

BAIL08APH174GVA

BAIL08APH174GVA 2

Suspended and SuperSteer™ Front Axle Pinion (Class 3.5 Axle) Components (SuperSteer™ Front Axle Shown)

1.	Pinion	7.	Pinion nut
2.	Bearing	8.	Pinion seal
3.	Spacer	9.	Dust cover
4.	Differential casing	10.	Pinion flange
5.	Shim	11.	Pinion flange bolt
6.	Bearing		

- Depress the Auto Difflock switch three times.

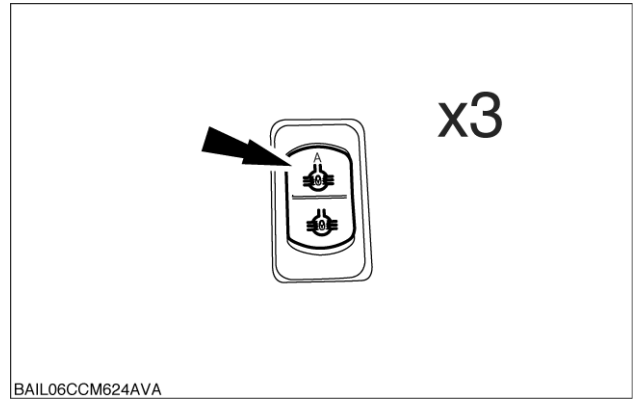

BAIL06CCM624AVA 3

- The lower central display will display "ScP" followed by the current steering sensor reading.

NOTE: If the display shows "-1" then the steering sensor option needs to be enabled using the H3 menu before the steering sensor can be calibrated.

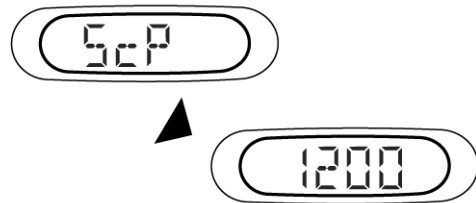

BAIL06CCM625AVA

BAIL06CCM625AVA 4

- Turn the steering wheel so that the front wheels are in line with the drive line.
- Depress the Auto Difflock switch three times.

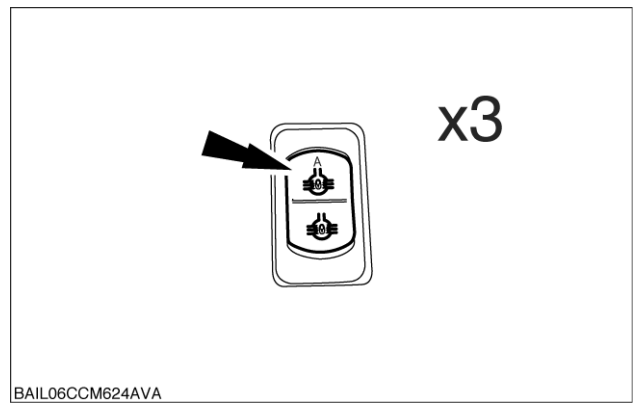

BAIL06CCM624AVA 5

- The lower central display will display the calibrated steering sensor reading and then "End" to indicate the calibration procedure has been completed.

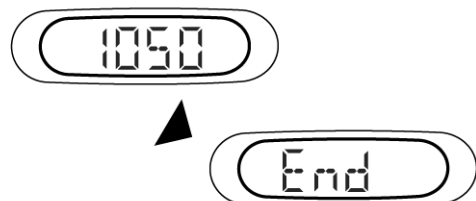

BAIL06CCM626AVA

BAIL06CCM626AVA 6

12. Remove the planet gear shaft, planet gears and thrust washers.

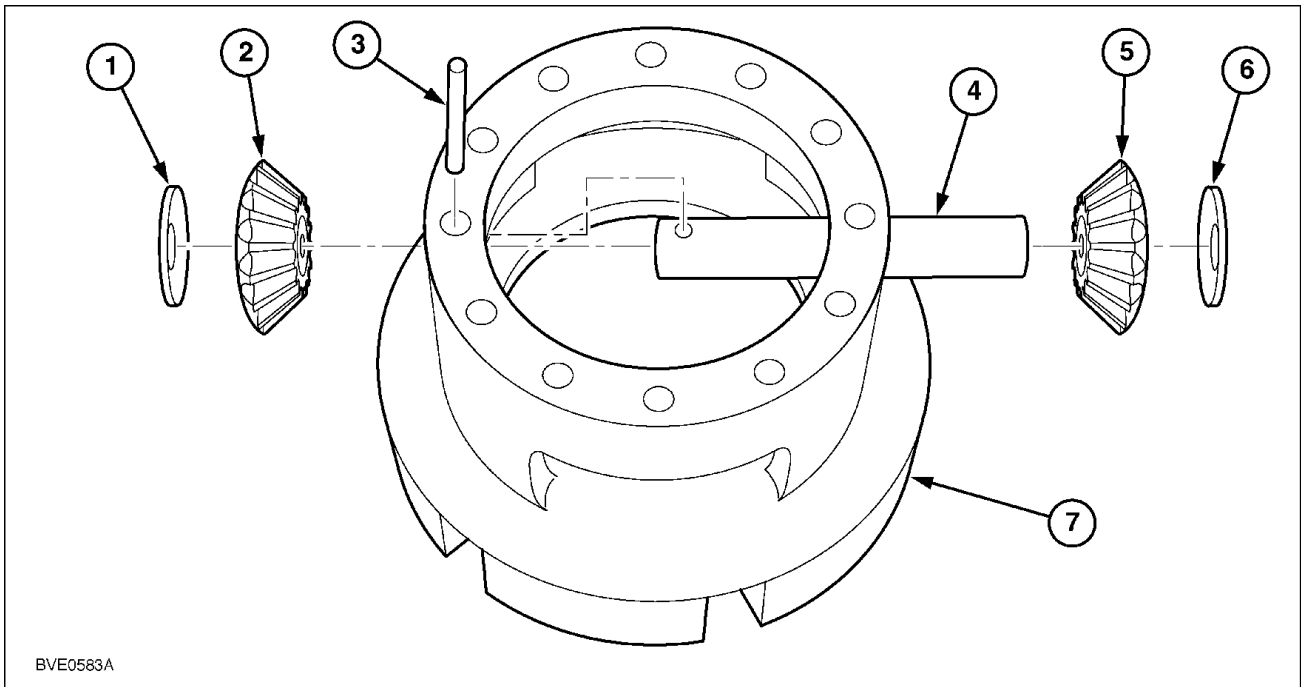
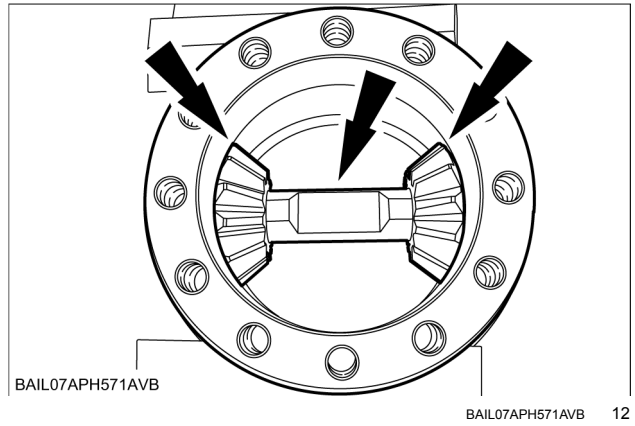

Illustration of the differential cage and planet gear assembly layout.

- | | |
|---------------------------------|---------------------|
| 1 Thrust washer | 2 Planet gear |
| 3 Planet gear shaft locking pin | 4 Planet gear shaft |
| 5 Planet gear | 6 Thrust washer |
| 7 Differential cage | |

Next operation:
Differential - Backlash (D.10.A).

Next operation:

Differential - Disassemble (D.10.A).

11. Install the drive gear onto the drive shaft pushing it fully back.
With the drive gear fully back ease the drive shaft out 10 mm to reveal the groove for the collets.

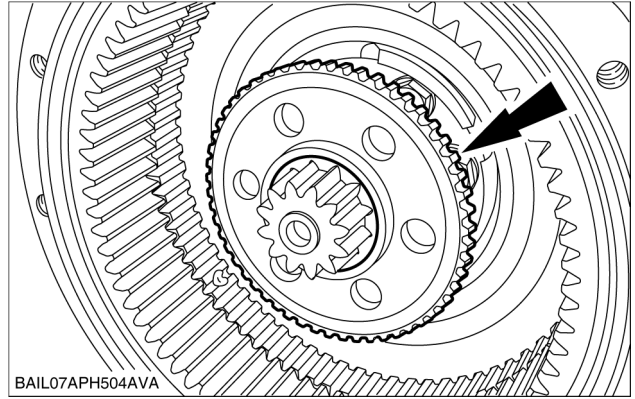

BAIL07APH504AVA 12

12. Install the collets (1).
Push the drive shaft back so that the drive gear (2) holds the collets in place.

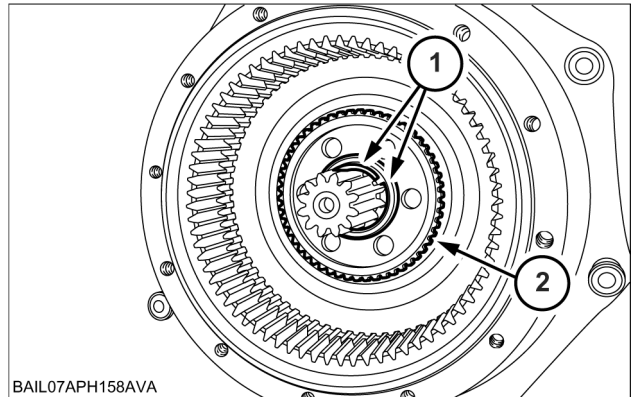

BAIL07APH158AVA 13

13. Install the inboard steel brake disc.

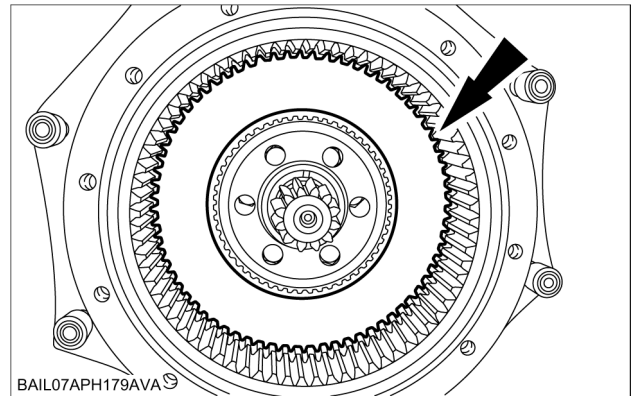

BAIL07APH179AVA 14

14. Install the friction disc.

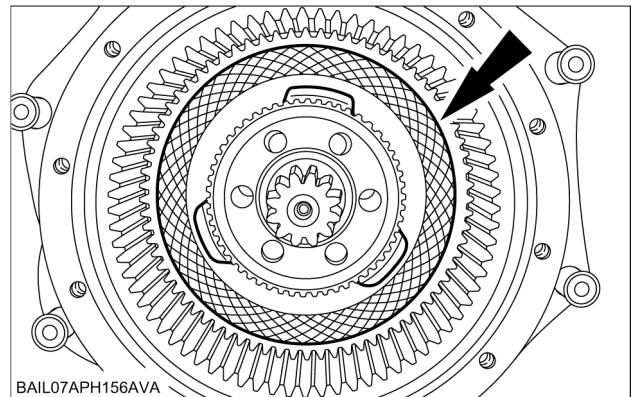

BAIL07APH156AVA 15

REAR AXLE - Sectional view

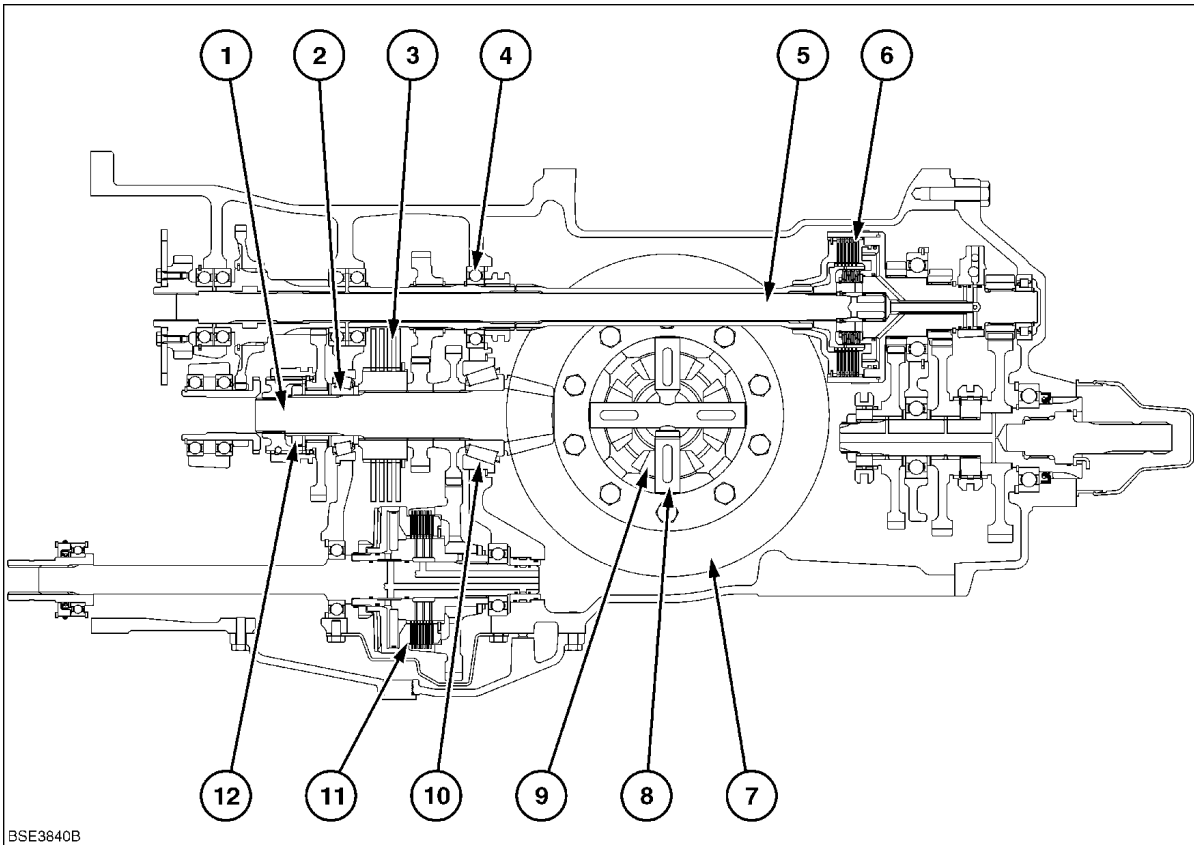

BSE3840B 1

Rear Axle Longitudinal Cross-Sectional View

- | | | | |
|----|-------------------------|----|---------------------------------------|
| 1 | Pinion shaft | 2 | Tapered roller bearing |
| 3 | Parking brake discs | 4 | Roller bearing |
| 5 | PTO drive shaft | 6 | PTO clutch |
| 7 | Crown wheel | 8 | Planet gear shafts |
| 9 | Planet gears | 10 | Pinion shaft position adjustment shim |
| 11 | Four wheel drive clutch | 12 | Pinion shaft retaining nut |

29. Install the PTO torque sensor (1) (if fitted).

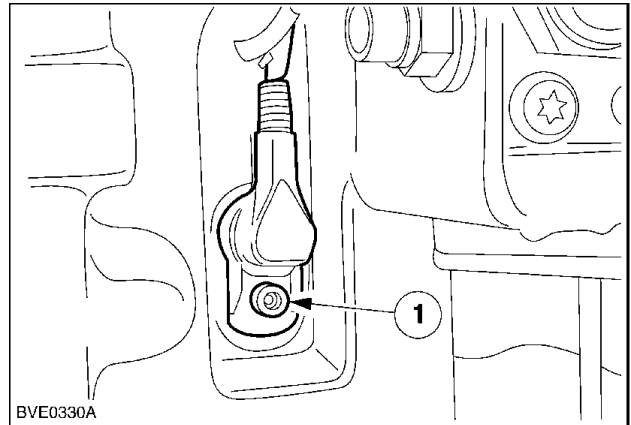

BVE0330A 28

30. Install the lower link support to the rear axle housing taking the following into consideration:
Thoroughly clean and degrease the mating surfaces and apply a bead of liquid gasket of approximately **2 mm (0.079 in)** in diameter to the rear axle casing - see **REAR AXLE - Sealing (D.12.A)**.
Install the lower link support. Tighten the retaining bolts to the specified torque value.

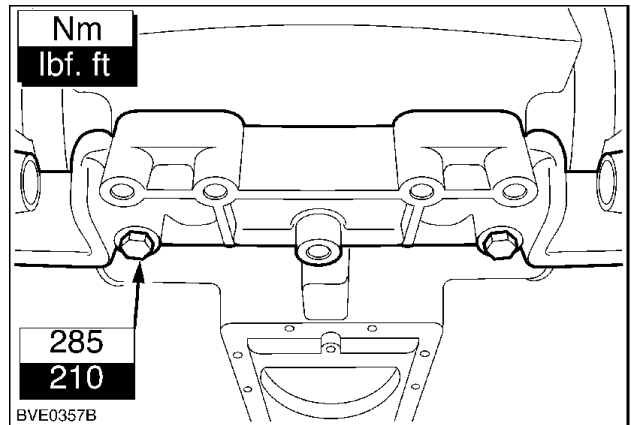

BVE0357B 29

31. Position the vertical tie rod. Install the vertical tie rod pivot pin (2). Install the vertical tie rod pivot pin retaining bolt (1).

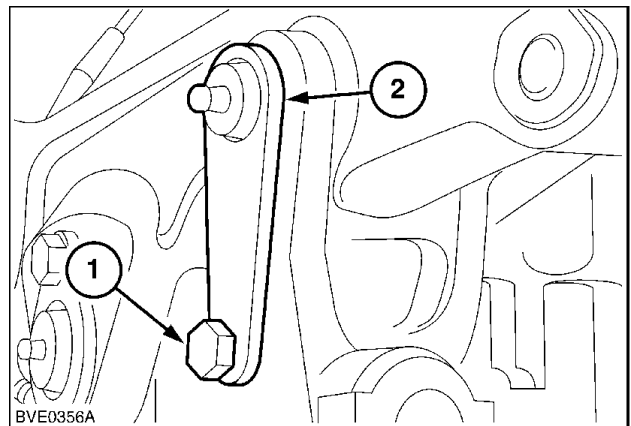

BVE0356A 30

32. Position the lower link. Install the draft sensor with its mounting plate and install the retaining bolts.

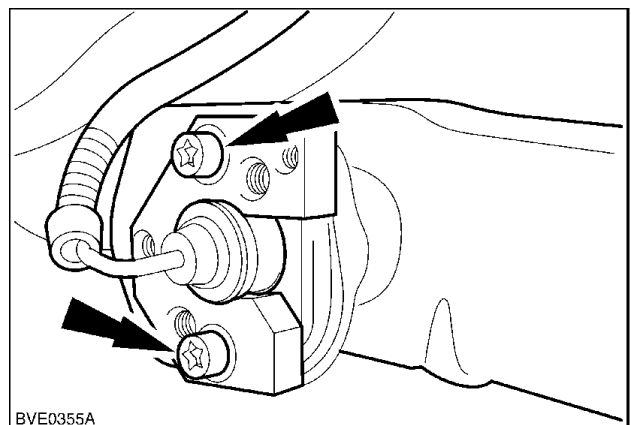

BVE0355A 31

4. Determine the pinion shaft position adjustment shim (**Sp**) as follows:

$$Sp = H1 - H2$$

Where :

H1 = Depth gauge reading

H2 = Correct nominal dimension between the crown wheel centre line and the rear face of the pinion shaft gear

Example

- Depth gauge reading:

H1 = **181.85 mm (7.159 in)**

- Nominal dimension between the crown wheel centre line and the rear face of the pinion shaft gear:

H3 = **180 mm (7.087 in)**

- Correction factor: C = **-0.18 mm (-0.007 in)**

- Correct nominal dimension:

H2 = 180 - 0.18 = **179.82 mm (7.080 in)**

- Shim thickness:

Sp = 181.85 - 179.82 = **2.03 mm (0.080 in)**.

NOTE: If required, increase (**Sp**) to the nearest available shim size.

5. Remove the special tool **380000249** and the locally fabricated pinion shaft position adjustment tool from the rear axle housing.
6. Remove the left and right hand side differential supports from the rear axle housing.
7. Install the pinion shaft rear bearing outer cone with the newly calculated position adjustment shim.
8. Position the inner parts through the parking brake compartment and install the pinion shaft.

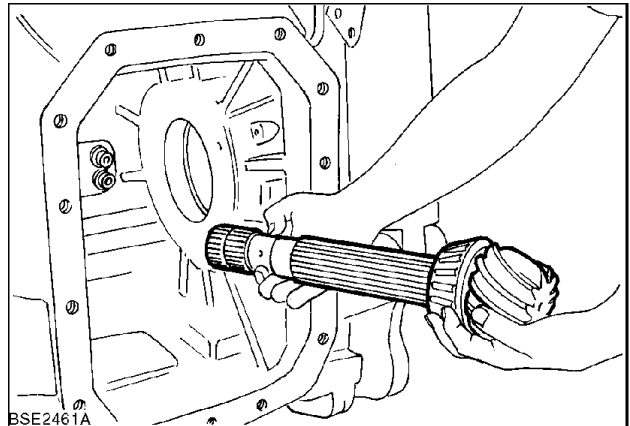

BSE2461A 5

Hydraulic line - Install

Prior operation:

Hydraulic line - Remove (D.14.C)

1. Install new O-rings (1) onto the oil supply manifold.

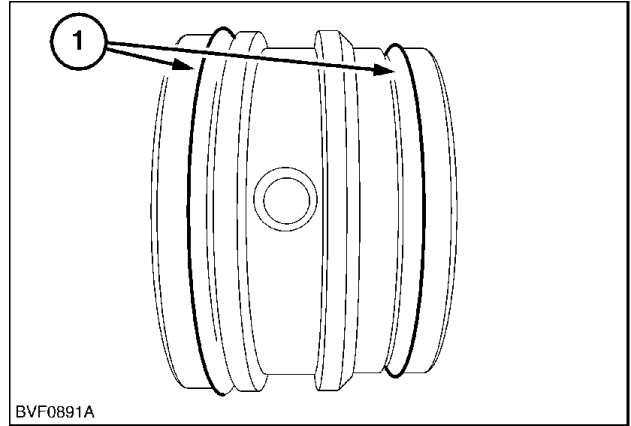

BVF0891A 1

2. Install the oil supply manifold (2) and the bearing (1) into the rear axle housing.

NOTE: Make sure the hole (4) in the oil supply manifold is aligned with the hole (3) in the rear axle housing.

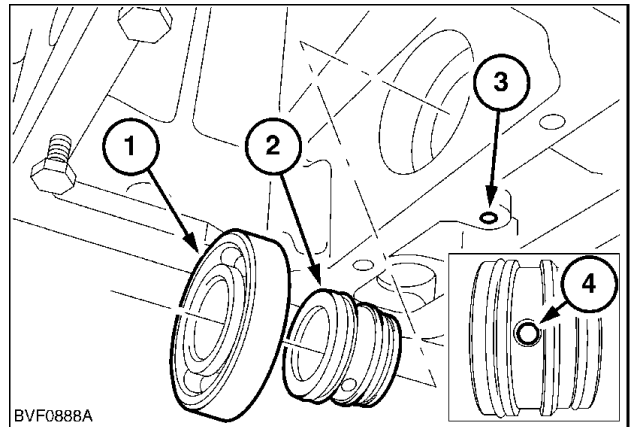

BVF0888A 2

3. Install the oil supply manifold retaining pin (1) and a new O-ring (2).

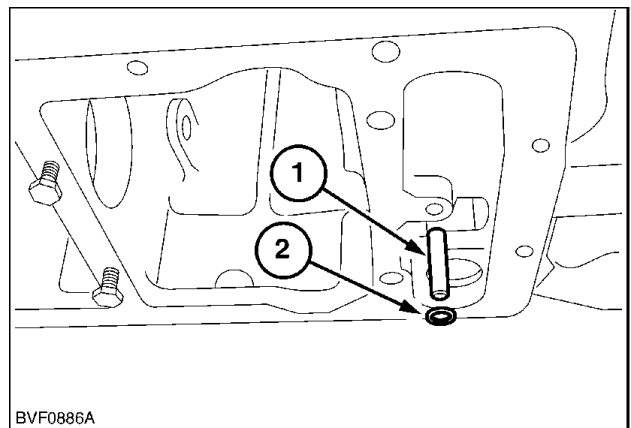

BVF0886A 3

Next operation:

Install the power take-off housing - see **REAR PTO Hydraulic - Install (C.40.C)**.

Install the four wheel drive clutch - see **Clutch - Install (D.14.C)**.

STEERING Hydraulic - General specification

PUMP SPECIFICATIONS

	2WD	4WD
Minimum Pump Output	40 l (8.8 UK gal)	
Steering Motor Displacement	100 cm ³ /rev (6.10 in ³ /rev) with Std Axle	160 cm ³ /rev (9.76 in ³ /rev)
	125 cm ³ /rev (7.63 in ³ /rev) with HD Axle	
Relief Valve Maximum Differential Pressure Setting	145 bar (2103 psi) with Std Axle	170 bar (2465 psi)
	170 bar (2465 psi) with HD Axle	
Absolute Gauge Pressure	161 bar (2335 psi) with Std Axle	186 bar (2697 psi)
	186 bar (2697 psi) with HD Axle	

TWO WHEEL DRIVE AXLE

Maximum Steering angle	55 °
Steering Wheel Turns (Lock to Lock)	3,3
Cylinder	1 off Double Acting
Turning Radius with Brakes	3.28 m (10.76 ft)
Turning Radius less Brakes	3.66 m (12.01 ft)
Toe-out	0 - 13 mm (0 - 0.51 in)

FOUR WHEEL DRIVE AXLE

	4 cyl.	6 cyl.
Maximum Steering angle	55 ° or 65 ° with SuperSteer	
Steering Wheel Turns (Lock to Lock)	3,9	
Cylinder	2 off double acting	
Turning Radius with Brakes (4WD disengaged)	3.51 m (11.52 ft)	3.745 m (12.29 ft)
Turning Radius less Brakes (4WD disengaged)	4.04 m (13.25 ft)	4.355 m (14.29 ft)
Turning Radius with Brakes (with SuperSteer)	3.495 m (11.47 ft)	-
Turning Radius less Brakes (with SuperSteer)	3.755 m (12.32 ft)	-
Toe-In	0 - 3 mm (0 - 0.12 in)	

4. Apply a light coating of hydraulic oil onto the sleeve and insert into the steering motor body. Coat the 'O' ring and back-up ring, with hydraulic fluid and position them onto the seal installer guide.

NOTE: Use special tool No. **380000281** to install oil seal type roto-glyd.

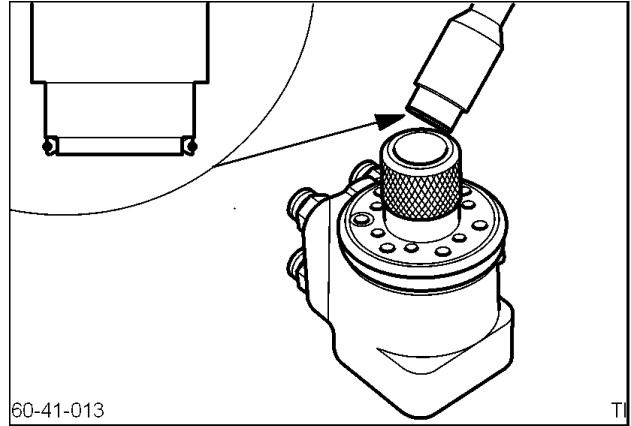

60-41-013

TI

60-41-013 4

5. Position the seal guide tool into the sleeve and push down with a twisting action. Remove tools once the seal has seated.

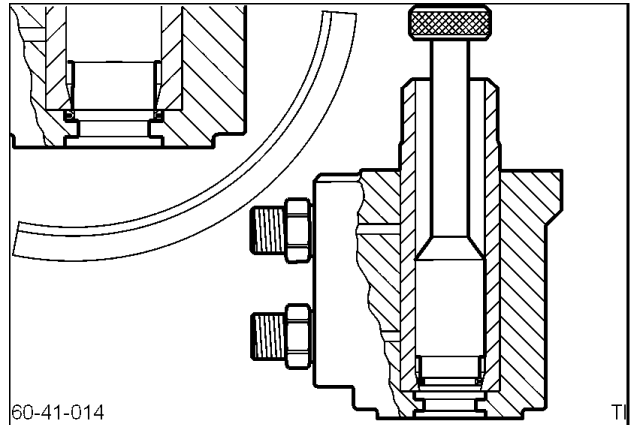

60-41-014

TI

60-41-014 5

6. With the seal installed in the motor body refit control valve.

NOTE: Ensure that the Drive is in a horizontal position to aid re-assembly.

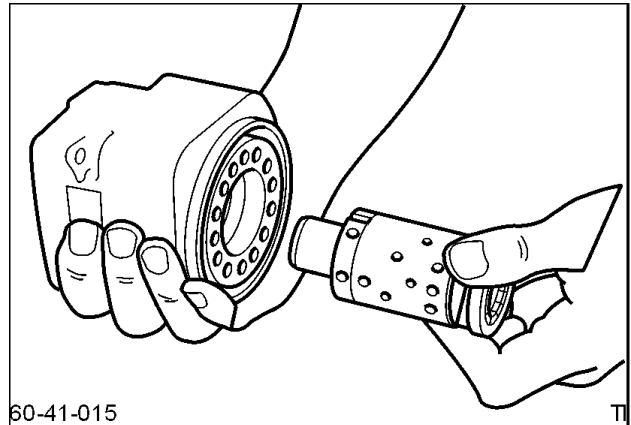

60-41-015

TI

60-41-015 6

7. Once the control valve is seated correctly refit the check and suction valves (2WD only). Screw the check valve down to just below the surface of the housing.

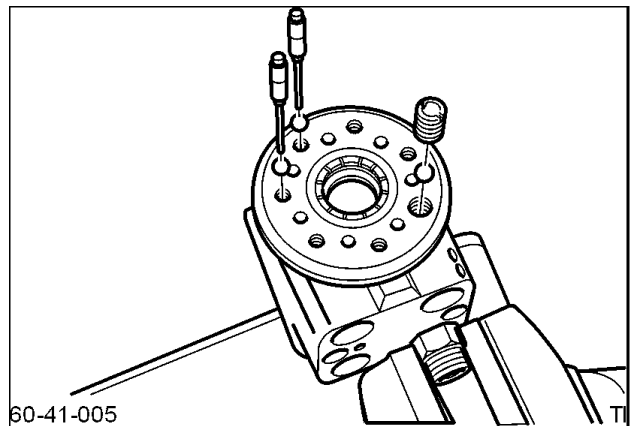

60-41-005

TI

60-41-005_500 7

Steering column - Visual inspection

1. Inspect the steering shaft universal joint and lower rubber coupling. Replace if any free play is evident.
2. Inspect the column assembly, if damaged or the bushes are worn a new assembly will be required.

Brake - Assemble

⚠ WARNING ⚠

Handle all parts carefully. Do not put your hands or fingers between parts. Wear suitable safety clothing - safety goggles, gloves and shoes.

B026

1. Remove the inner and outer piston oil seals from the piston carrier plate. Ensure the carrier is free from any debris and carefully install the new oil seals, allow the oil seals to relax for a few minutes prior to installing the piston.

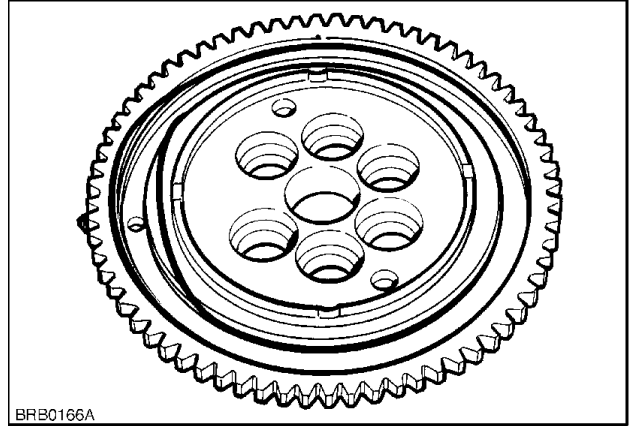

BRB0166A 1

2. Remove the oil transfer tube from the rear of the carrier and replace the O-rings.

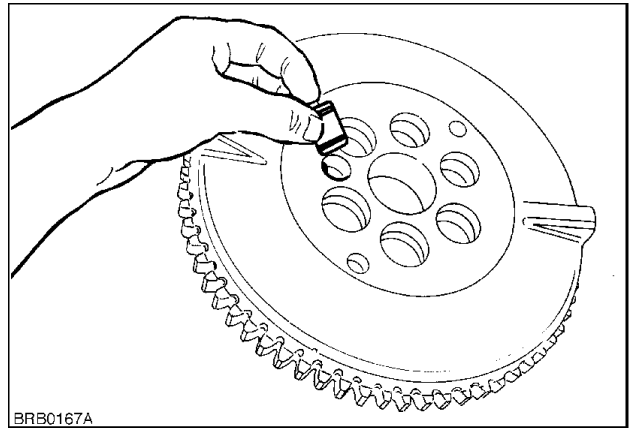

BRB0167A 2

3. Lubricate the piston with the specified brake oil and install the piston into the carrier.

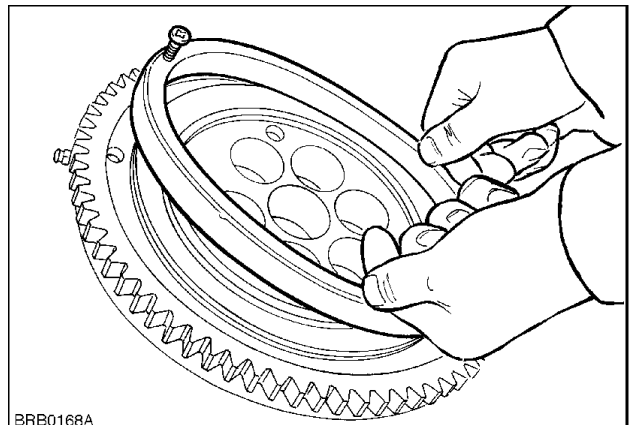

BRB0168A 3

Contents

AXLES, BRAKES AND STEERING - D

BRAKE CONNECTION Hydraulic - 34.C

TECHNICAL DATA

BRAKE CONNECTION Hydraulic

General specification	3
Torque	3
Special tools	3

FUNCTIONAL DATA

BRAKE CONNECTION Hydraulic

Dynamic description (Italian Trailer Brake)	4
---	---

Trailer brake valve

Dynamic description	12
Static description	16
Static description (Italian Trailer brake)	17
Exploded view (Italian Trailer brake)	18
Hydraulic schema	19
External view	20

SERVICE

Trailer brake valve

Remove	21
Install	23
Remove (Solenoid valve block Italian Trailer brake)	25
Install (Solenoid valve block Italian Trailer brake)	26
Pressure test	27

DIAGNOSTIC

Trailer brake valve

Troubleshooting	31
Troubleshooting (Italian Trailer brake)	31

Index

AXLES, BRAKES AND STEERING - D

BRAKE CONNECTION Hydraulic - 34.C

BRAKE CONNECTION Hydraulic - Dynamic description (Italian Trailer Brake)	4
BRAKE CONNECTION Hydraulic - General specification	3
BRAKE CONNECTION Hydraulic - Special tools	3
BRAKE CONNECTION Hydraulic - Torque	3
Trailer brake valve - Dynamic description	12
Trailer brake valve - Exploded view (Italian Trailer brake)	18
Trailer brake valve - External view	20
Trailer brake valve - Hydraulic schema	19
Trailer brake valve - Install	23
Trailer brake valve - Install (Solenoid valve block Italian Trailer brake)	26
Trailer brake valve - Pressure test	27
Trailer brake valve - Remove	21
Trailer brake valve - Remove (Solenoid valve block Italian Trailer brake)	25
Trailer brake valve - Static description	16
Trailer brake valve - Static description (Italian Trailer brake)	17
Trailer brake valve - Troubleshooting	31
Trailer brake valve - Troubleshooting (Italian Trailer brake)	31

Rear wheel - Torque

Flanged Axle

Disc to hub nuts	250 Nm (184.4 lb ft)
Disc to rim nuts	250 Nm (184.4 lb ft)

Bar Axle

Disc to hub nuts	250 Nm (184.4 lb ft)
Disc to rim nuts	250 Nm (184.4 lb ft)
Split wedge bolts	300 Nm (221.3 lb ft)

- A **REAR PTO SPEED SENSOR**
Sensor output modulates as signal voltage to the instrument cluster to display PTO speed.
- B **TRANSMISSION OUTPUT SPEED SENSOR**
Senses transmission output (wheel) speed and generates a signal for cluster ground speed display, distance display, and to compute area accumulations.
When a radar is fitted, the transmission speed sensor is used only to compute % slip display.
- C **AIRBRAKE PRESSURE SENSOR/SWITCH**
Resistance varies with air pressure, when pressure is below **5.2 bar (75.4 psi) ± 0.3 bar (4.4 psi)** the switch closed and the warning lamp is activated.

Pressure	0 bar (0.0 psi)	1 bar (14.5 psi)	2 bar (29.0 psi)	3 bar (43.5 psi)	4 bar (58.0 psi)	5 bar (72.5 psi)	6 bar (87.0 psi)	7 bar (101.5 psi)	8 bar (116.0 psi)	9 bar (130.5 psi)	10 bar (145.0 psi)
Resistance (Ω)	10	31	52	71	88	106	124	140	155	170	184

- D **DIFFERENTIAL LOCK PRESSURE SWITCH**
Operates when transmission oil pressure **11 bar (159.5 psi)** is present in differential lock supply lines to illuminate warning lamp.
Switch is normally open.
- E **TRANSMISSION OIL PRESSURE SWITCH**
Operates as transmission oil pressure drops below **11 bar (159.5 psi)** to operate warning lamp.
Switch is normally closed.
- F **4WD PRESSURE SWITCH**
Operates when transmission pressure **11 bar (159.5 psi)** is absent in 4WD line (4WD engaged) to illuminate warning lamp.
Switch is normally closed.
- G **BRAKE PEDALS NOT LATCHED SWITCH**
Operates when brake pedals are not latched to display warning lamp.
- H **RADAR SENSOR (Optional)**
Senses true ground speed and generates a signal for cluster ground speed, % slip, distance displays and to compute area accumulations.

Instrument panel Analogue-digital instrument cluster - Dynamic description Performance Monitor Functions with Enhanced Keypad (where fitted)

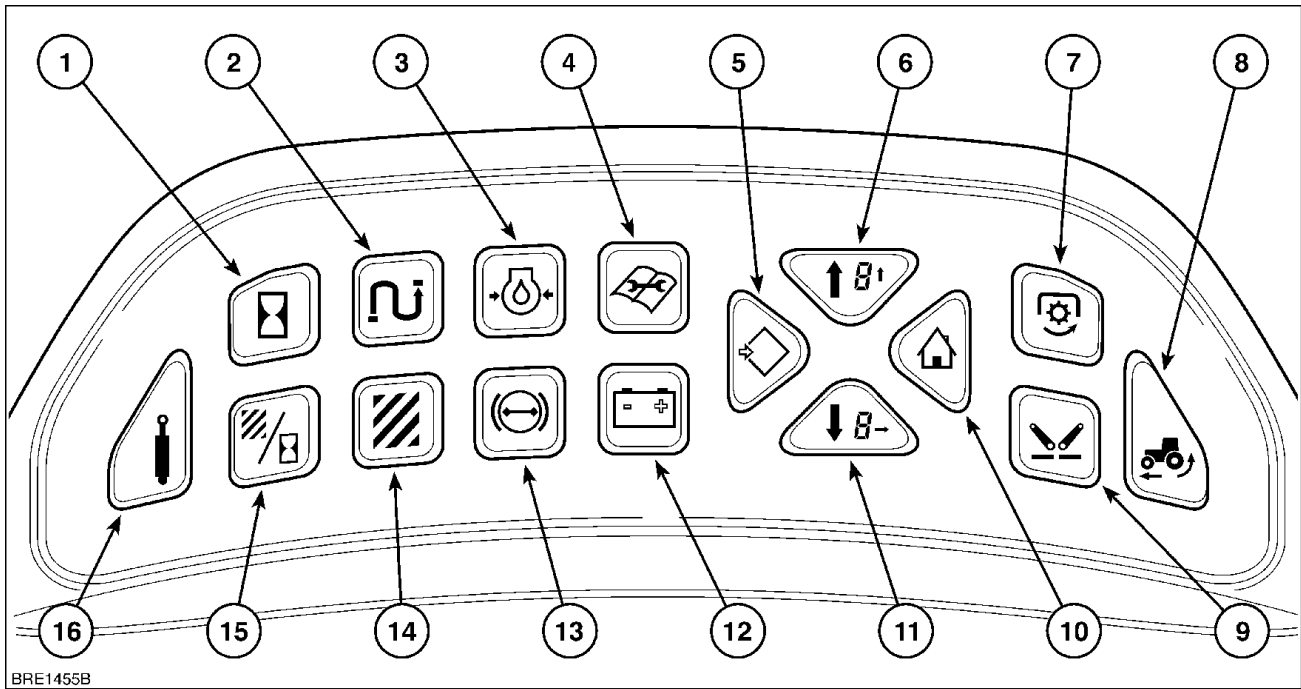

BRE1455B_588 1

The enhanced keypad consists of 16 buttons or 'keys' that select, control or programme various functions and displays in the central and dot matrix screens. Keys **(5)**, **(6)**, **(10)** and **(11)** are used to set-up and programme many of the enhanced keypad functions.

Unless otherwise described, depress the keys once to obtain the appropriate display. A symbol will appear in the display to confirm the function selected.

Legend:

(C) = Centre Digital Display

(D) = Dot Matrix Display

- | | |
|---|--|
| <p>1. Hourmeter (D).
Touch the key to view total number of hours that the tractor has operated. The hours recorded should be used as a guide to the service intervals for the tractor.</p> <p>3. Engine Oil Pressure (D).
This key will display the engine oil pressure bargraph.</p> <p>5. Menu Enter (D).
Depress to select set-up and programming modes.</p> <p>7. P.T.O. Speed (C).
Depress once to display rear Power Take Off speed, press twice to show front P.T.O. speed (where fitted).</p> | <p>2. Odometer (D).
The odometer provides a visual record of the distance travelled in kilometres or miles depending on the ground speed unit selected. Two displays are available, '1' and '2'.</p> <p>4. Programmed Maintenance Reminder (D).
The maintenance schedule key provides two levels of reminder identified as 'Heavy' and Light.</p> <p>6. Menu Scroll Up or Digit Value (D).
Depress this key repeatedly to scroll upwards through the menu or change the value of a number.</p> <p>8. Rear Wheel Slip (C).
The level of rear wheel slip will appear as a one or two digit percentage (%) figure (with radar option only).</p> |
|---|--|

Tractors with Mechanical Fuel Injection Pump

16. Attach the throttle cable to the fuel injection pump (2) and tighten the retaining nut (1).

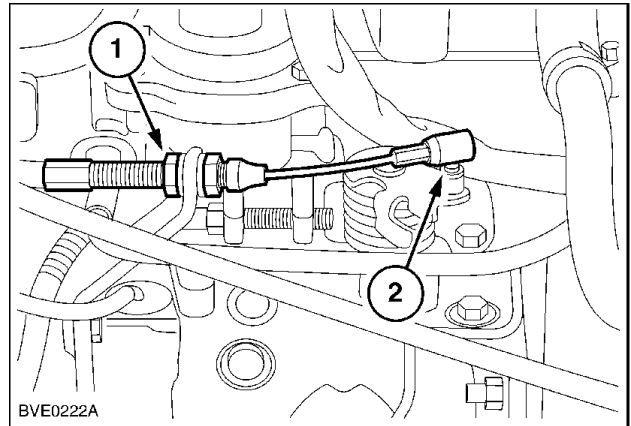

BVE0222A_58 15

All Tractors

17. Attach the creeper gear cable and install the R-clip (1) (if fitted).

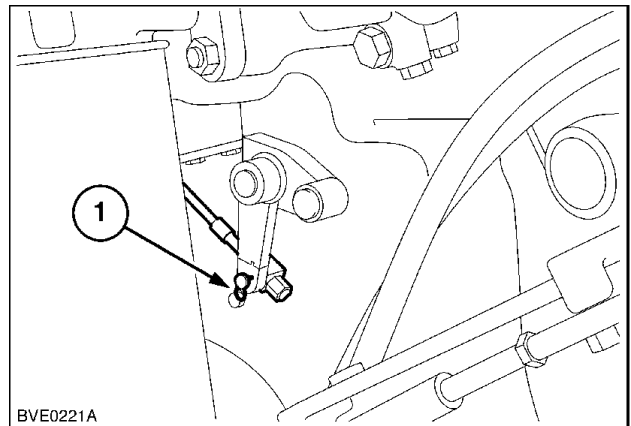

BVE0221A 16

18. Connect the brake fluid lines (1), (2) and (3) to the brake fluid reservoir.

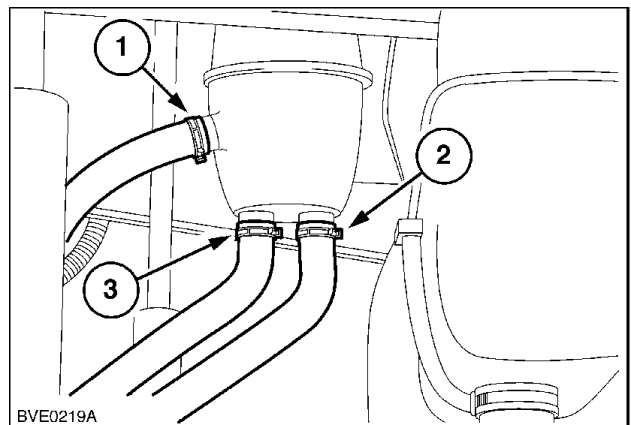

BVE0219A_57 17

"MANUAL" control mode

The manual mode can be selected by moving the blower speed switch **(1)** to the position "I, II or III" and using the temperature control potentiometer **(3)** to set the desired temperature. The blower speed is varied to reach the set value and then remains constant. In this case the system attempts to attain the desired temperature in the cab simply by changing the air temperature and the blower speed selected by the driver remains unchanged. If you would like to return to the automatic control mode switch the blower speed switch **(1)** to position "A" (automatic).

You can set the maximum cooling power by setting the temperature control potentiometer **(3)** to "LO" (turn all the way to the left). The air conditioner works at maximum cooling power in this mode.

The blower can be switched on in two ways:

- Turn the blower speed switch **(1)** to position "A". In this operating mode the blower is set to maximum speed.
- The blower speed is set manually to position "I, II or III".

You can set the maximum heating power by setting the temperature control potentiometer **(3)** to "HI" (turn all the way to the right). The heating system works at maximum power in this mode.

The blower can be switched on in two ways:

- Turn the blower speed switch **(1)** to position "A". In this operating mode the blower is set to maximum speed.
- The blower speed is set manually to position "I, II or III".

"ECONOMY" air conditioner mode.

The economy mode can be selected by moving the operating mode switch **(2)** to the position "ECON" (left position) and moving the blower speed switch **(1)** to position "A". Use the temperature control potentiometer **(3)** to set the desired temperature. If the outside temperature is low the air conditioner does not have to be running in order to maintain a constant cab temperature. In this mode the unit attempts to keep the desired value constant by regulating the heating valve and the blower speed. If the outside air temperature rises above the desired value selected, (cab temperature) the air conditioner must be switched on in order to attain the desired value.

"MAX DEF" mode.

The purpose of the "MAX DEF" mode is to remove moisture that collects on the windows of the cab in the form of fog or ice. Use the operating mode switch **(2)** to select the "MAX DEF" position and move the blower speed switch **(1)** to position "A". In this mode the heating system and the air conditioner are running; the blower runs at maximum speed. The blower speed can also be set manually. If this mode is used to defrost the windows, the temperature control potentiometer **(3)** should be turned to the "HI" position. In this position an air outlet temperature is attained which is as high as possible when the air conditioner is running in order to defrost the windows. If the windows are heavily fogged with moisture it is not necessary to change the set temperature (desired value) using the temperature control potentiometer **(3)**. In order to exit the "MAX DEF" mode and enter another operating mode. Move the operating mode switch **(2)** to the middle position (air conditioner "ON") or to the "ECON" position (air conditioner "OFF")

7. Operate the recovery system in accordance with the manufacturers instructions.
The compressor will shut off automatically when the recovery is complete.

Compressor Magnetic clutch - Assemble

380000333 Air conditioning compressor toolkit

Prior operation:

Compressor Magnetic clutch - Disassemble (E.40.D)

1. Fit the exciter winding.
Secure the exciter winding using the circlip.

NOTE: The nose of the exciter winding must be seated in the hole of the compressor housing.

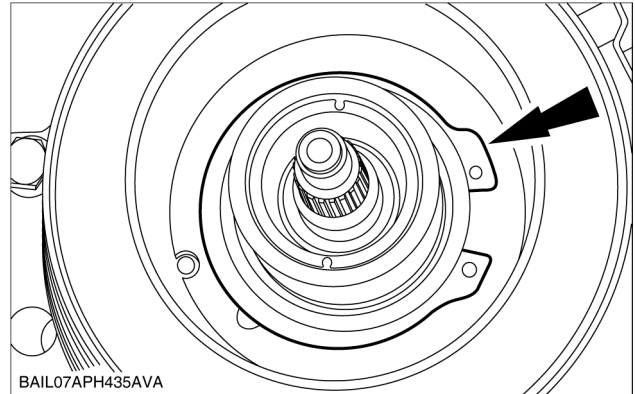

BAIL07APH435AVA

BAIL07APH435AVA 1

2. Fit cable clamp.

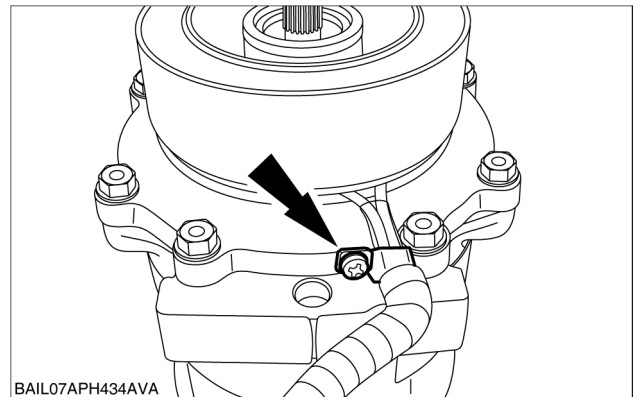

BAIL07APH434AVA

BAIL07APH434AVA 2

3. Use the special tool (1) (211-153/7) to drive the belt pulley bearing and the belt pulley (2) onto the hub of the compressor.

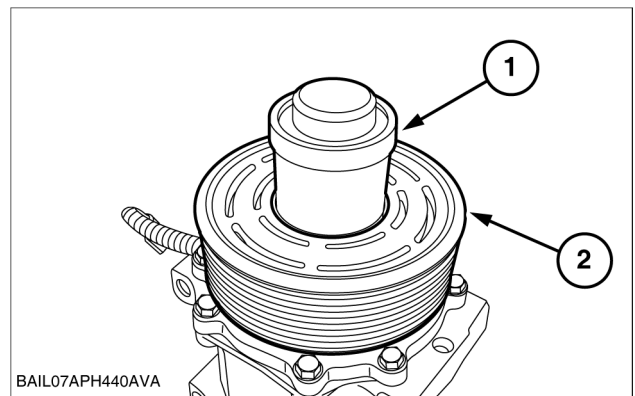

BAIL07APH440AVA

BAIL07APH440AVA 3

Assembly

8. Install the climate controller.

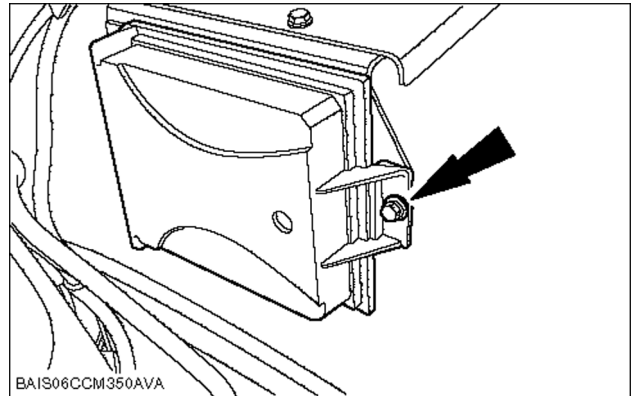

BAIS06CCM350AVA 8

9. Connect the electrical connector (2) and attach the tab (1).

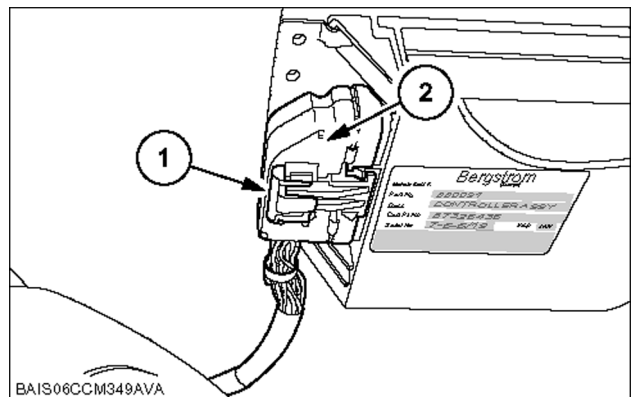

BAIS06CCM349AVA 9

10. Attach the side covering on the left.

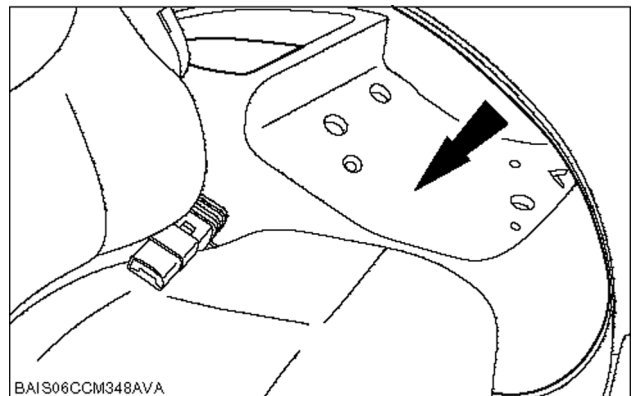

BAIS06CCM348AVA 10

11. Fit the air outlet on the left side.

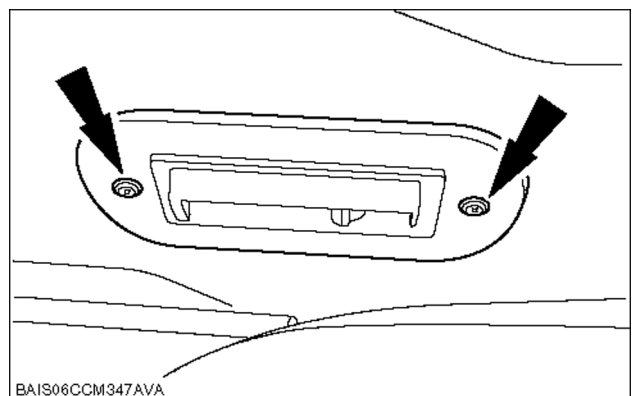

BAIS06CCM347AVA 11

HITCH Front hitch - Disassemble

 **WARNING** 

Handle all parts carefully. Do not put your hands or fingers between parts. Wear suitable safety clothing - safety goggles, gloves and shoes.

B026

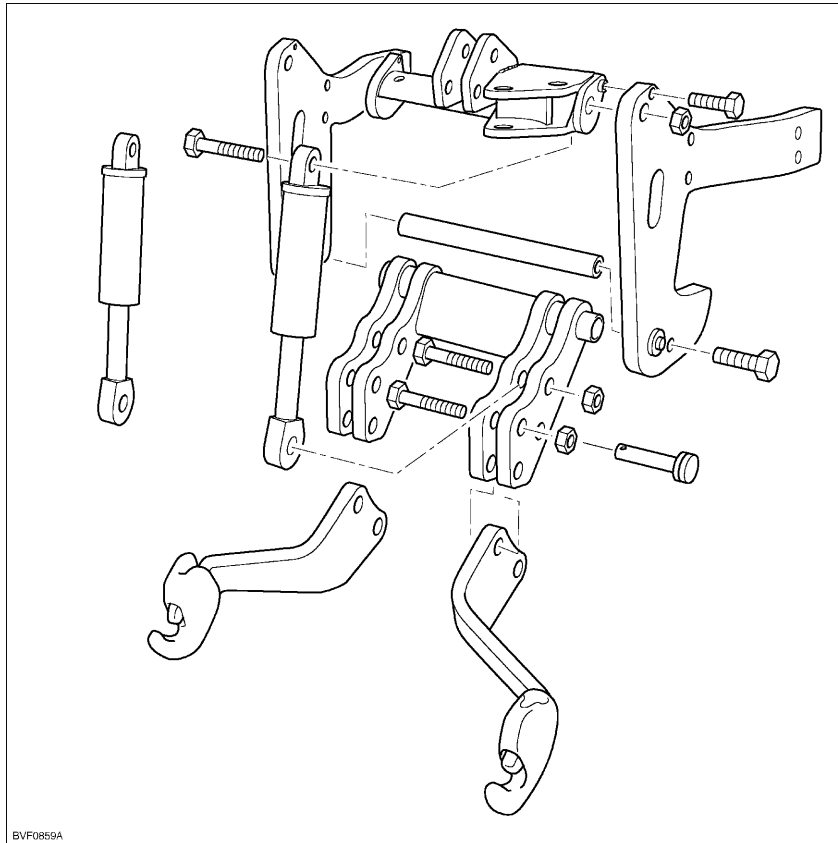

BVF0859A

BVF0859A_425 1

Draft Control Operation

When starting work, move the Position Control lever **(2)** fully forward and lower the implement into work using the Draft Control lever **(3)**. Push the lever forward to increase the draft loading. Pull rearwards to reduce the draft loading. In most circumstances forward movement of the lift control lever will increase implement depth and rearward movement will reduce the depth.

Once set, the tractor hydraulic system will automatically adjust the implement depth to maintain an even pull on the tractor and so reduce wheel slip to a minimum.

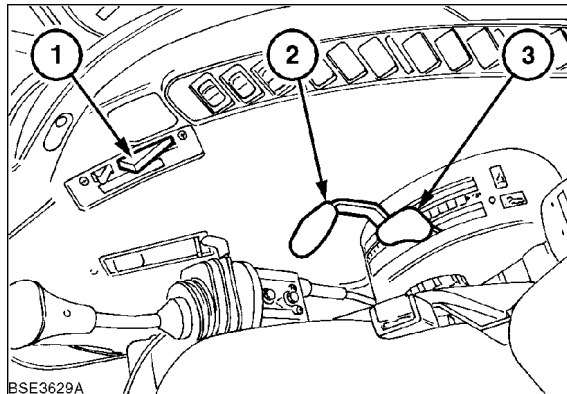

BSE3629A 6

Observe the implement as it pulls through the soil. If the hydraulic system reaction (vertical movement of the implement) is too great or too frequent then system sensitivity may be reduced by adjustment of the sensor bar spacers **(2)**. To move a spacer, remove the nut and bolt **(4)**, end stop **(3)**, spacer **(2)** and lower link **(1)**. Re-install the spacer first, followed by the lower link and end stop. Secure the end stop with the nut and bolt. Tighten the nut securely. This is the most sensitive position, recommended for light implements or light draft loads.

To reduce system sensitivity, move the spacers at each end of the sensor bar to the outside of the lower links as shown in illustration 7. This is the least sensitive position, recommended for heavier implements or heavy draft conditions. As with Position Control operation, use the fast raise button to raise and lower the 3-point linkage (and implement) at the end of each pass. Do not move the Draft Control lever as this will affect the previously determined setting.

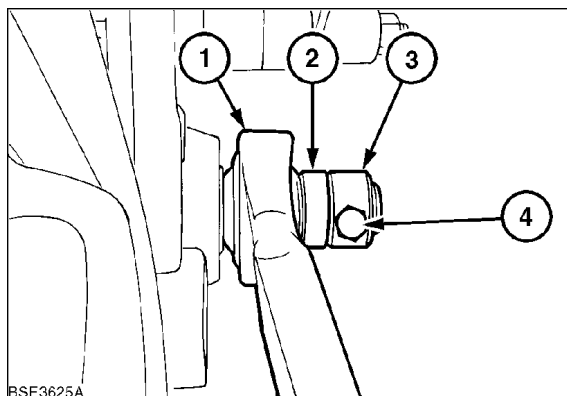

BSE3625A 7

7. Position the lift arms in the raised position. Place the position and draft control levers (1) in the fully lowered position.

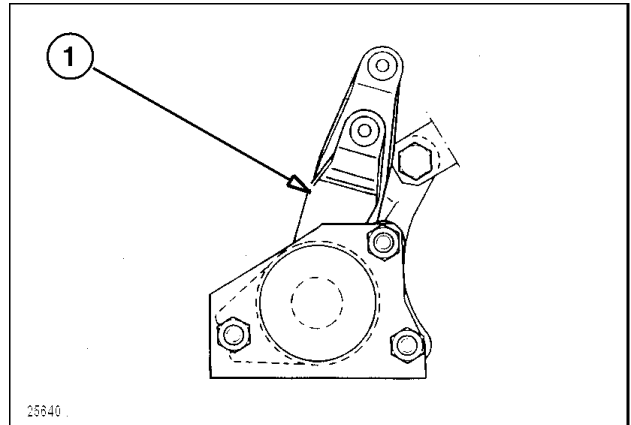

25640

25640 7

8. Remove the PTO housing - see **REAR PTO Hydraulic - Remove (C.40.C)**.

9. Remove the top section of the draft sensing control rod (1).

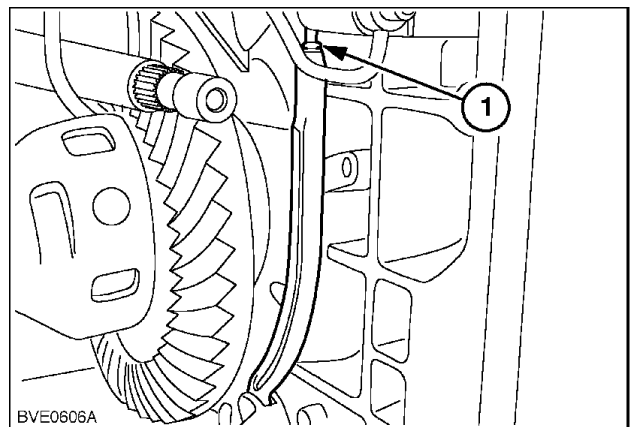

BVE0606A

BVE0606A 8

10. Attach the top section of the draft sensing control rod (3) to the extension adaptor of the special tool 380000263 (1). Place the special tool 380000263 (1) onto a surface plate and adjust the end of the rod (3) until the upper end of the rod is level with the special tool 380000263 (1). Tighten the locknut (2).

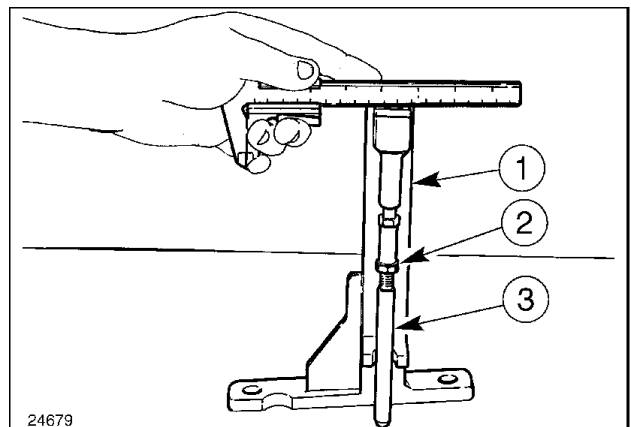

24679

24679 9

CLICK HERE TO **DOWNLOAD** THE COMPLETE MANUAL

- Thank you very much for reading the preview of the manual.
- You can download the complete manual from: www.heydownloads.com by clicking the link below



- Please note: If there is no response to CLICKING the link, please download this PDF first and then click on it.

CLICK HERE TO **DOWNLOAD** THE COMPLETE MANUAL