

SERVICE MANUAL

**T6.120 / T6.140 / T6.150 / T6.155 /
T6.160 / T6.165 / T6.175 /
T6.140 AutoCommand / T6.150 AutoCommand /
T6.160 AutoCommand
Tier 4A
Tractor**

Part number 47665870

English

March 2014

Replaces part number 47461584



CLICK HERE TO **DOWNLOAD** THE COMPLETE MANUAL

- Thank you very much for reading the preview of the manual.
- You can download the complete manual from: www.heydownloads.com by clicking the link below



- Please note: If there is no response to CLICKING the link, please download this PDF first and then click on it.

CLICK HERE TO **DOWNLOAD** THE COMPLETE MANUAL

7. Remove the smaller wheeled part of the splitting equipment from under the engine.
Remove the splitting equipment securing bolts from the transmission.
Remove the splitting equipment from under the transmission.

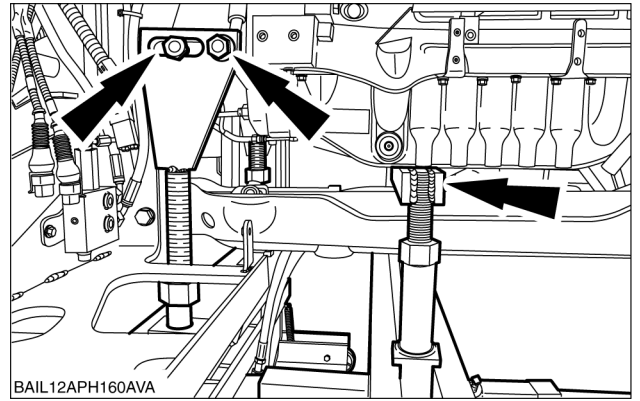

BAIL12APH160AVA 6

8. Place suitable axle stands under the front axle and support the vehicle. .
9. Remove the larger wheeled part of the splitting equipment from under the front weight carrier.

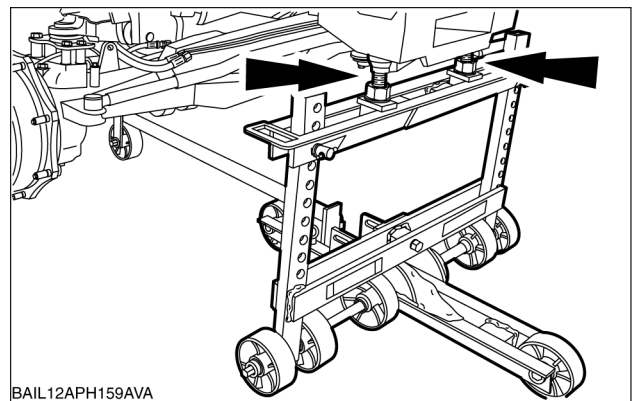

BAIL12APH159AVA 7

Vehicles with standard front axle

10. Install the drive shaft flange (if equipped).

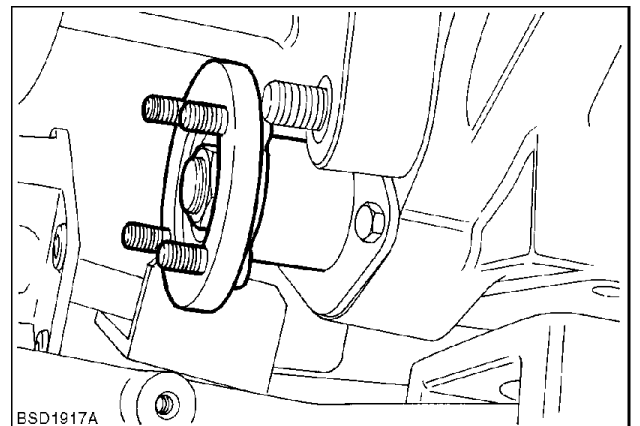

BSD1917A 8

20. Connect the fuel supply line to the water trap.

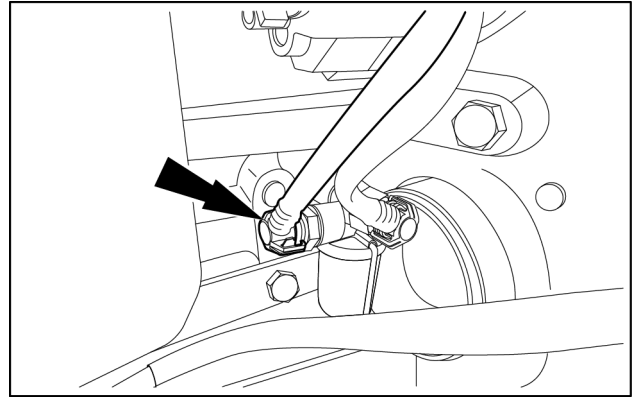

BAIL13TR00784AB 19

21. Install the bracket.

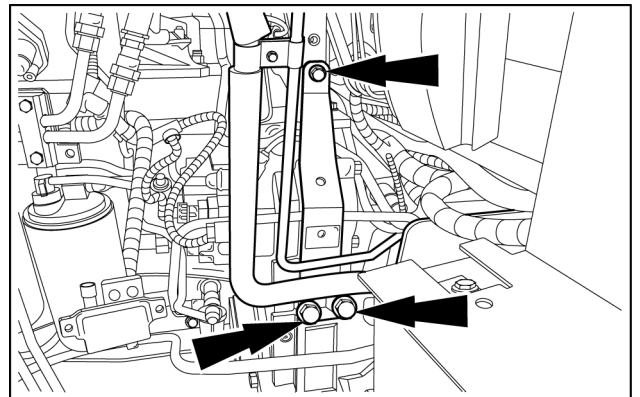

BAIL13TR00783AB 20

22. Install the A/C pipes retaining bracket.

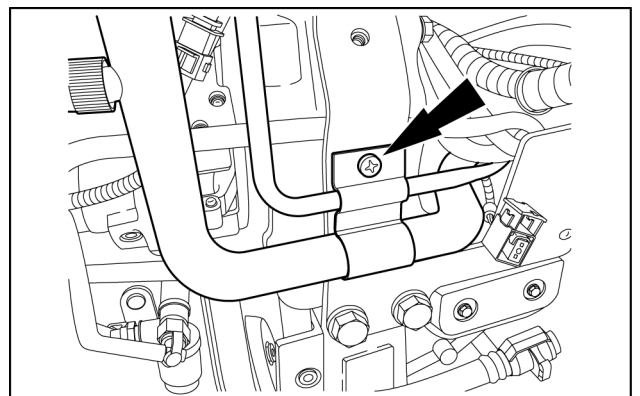

BAIL13TR00782AB 21

23. A. Connect the A/C pipe (2).
B. Install the air cleaner foreign matter outlet (1).

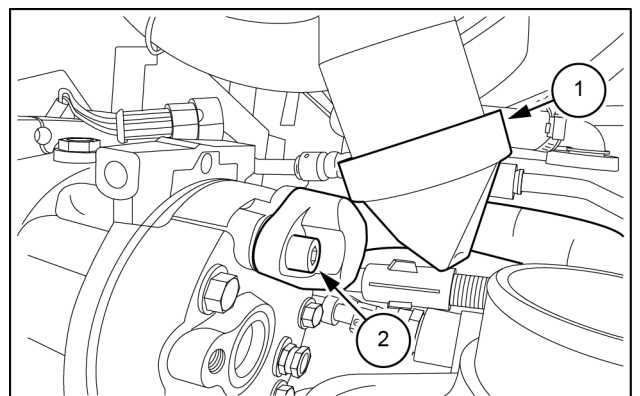

BAIL13TR00781AB 22



Engine - 10

Fuel injection system - 218

**T6.120 , T6.140 AutoCommand , T6.140 , T6.150 AutoCommand , T6.150 ,
T6.155 , T6.160 AutoCommand , T6.160 , T6.165 , T6.175**

12. Remove the exhaust line clamp shield.

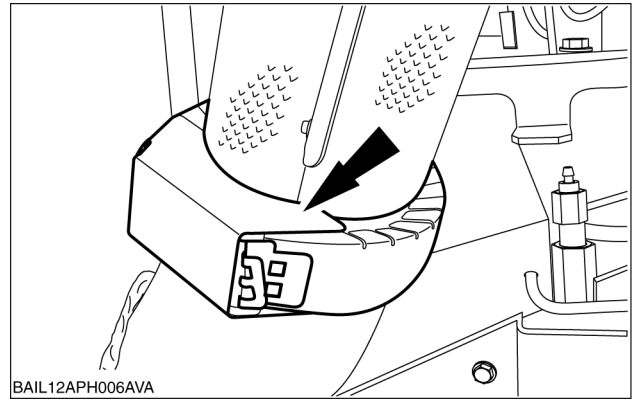

BAIL12APH006AVA 11

13. Disconnect the exhaust line clamp.

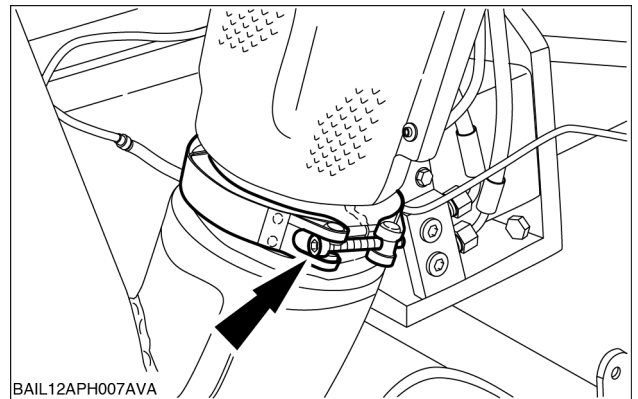

BAIL12APH007AVA 12

14. Detach the pre catalyst temperature sensor.

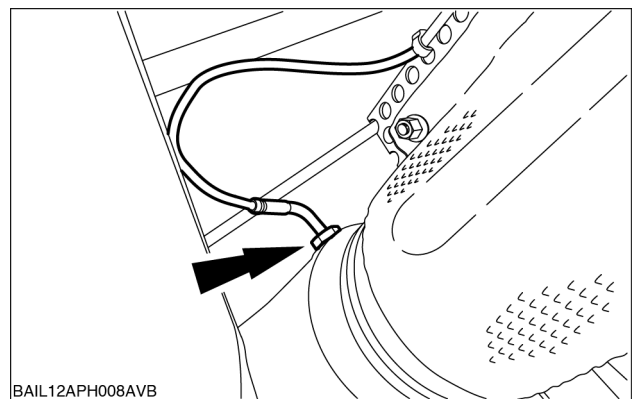

BAIL12APH008AVB 13

15. Remove SCR muffler and catalyst clamp retaining bolt.

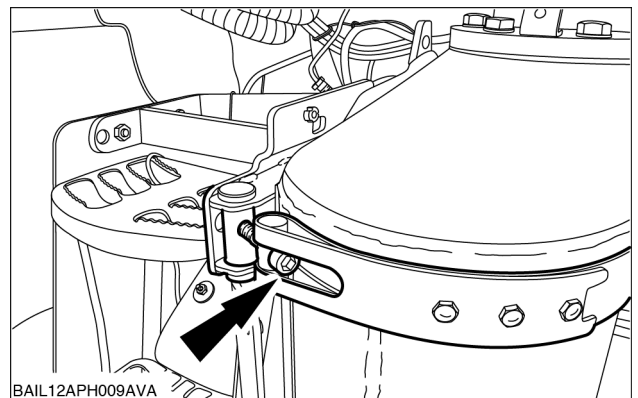

BAIL12APH009AVA 14



Engine - 10

Fan and drive - 414

**T6.120 , T6.140 AutoCommand , T6.140 , T6.150 AutoCommand , T6.150 ,
T6.155 , T6.160 AutoCommand , T6.160 , T6.165 , T6.175**

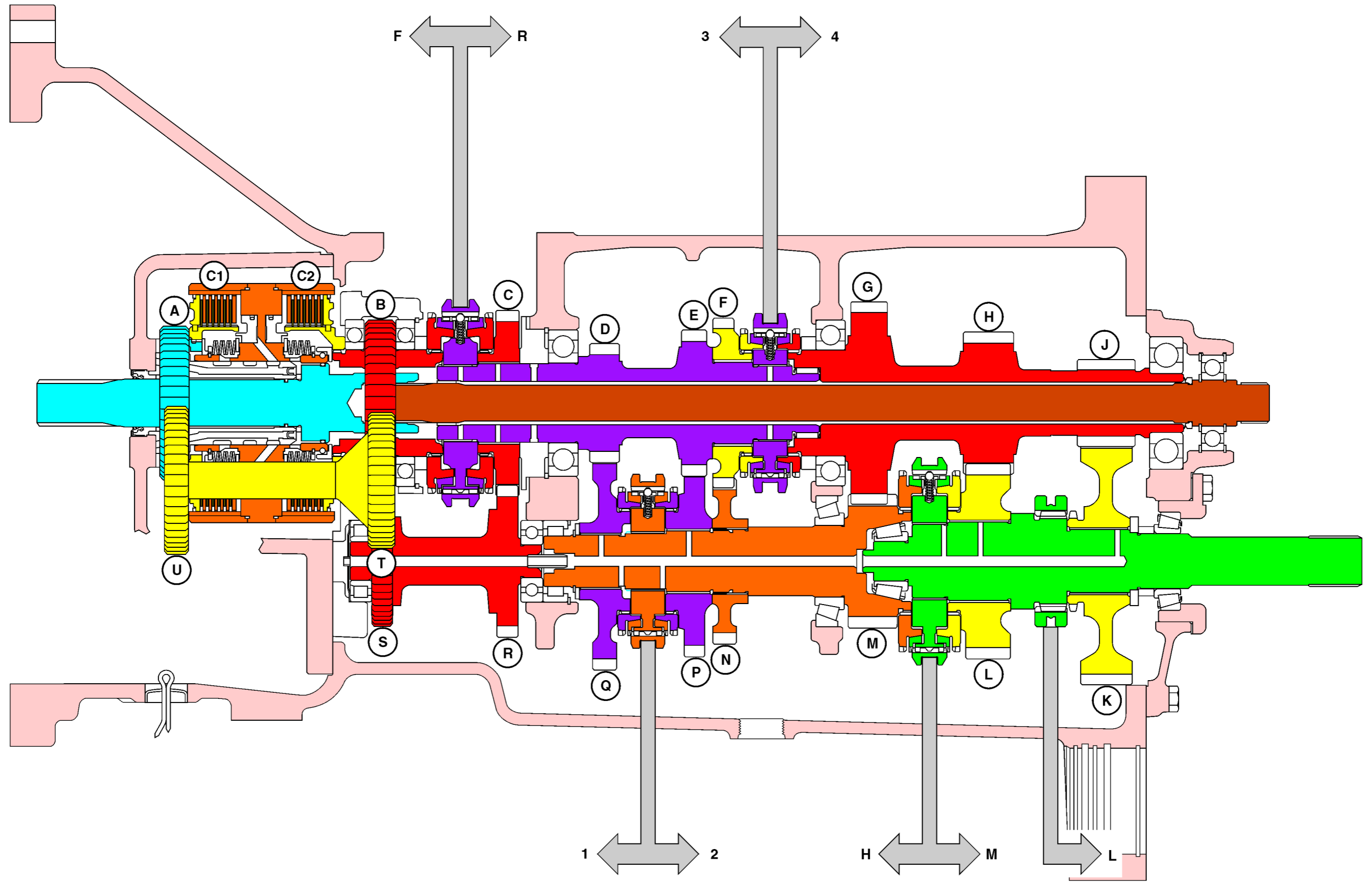

BSF4397B

BSF4397B 1

Transmission control levers - Travel adjust

T6.120	NA
T6.140	NA
T6.150	NA
T6.155	NA
T6.160	NA
T6.165	NA
T6.175	NA

1. Ensure the tractor is not in gear and the main shift and range levers are in the neutral position.
2. Check and if necessary adjust the length of both of the adjustable link rods.
 $X = 83.5 - 84.9 \text{ mm (3.29 - 3.34 in.)}$

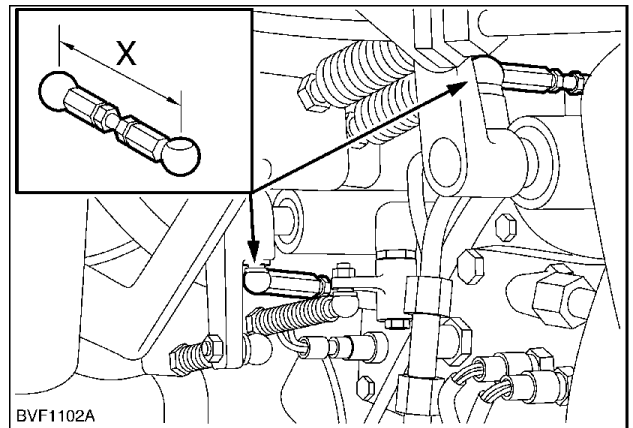

BVF1102A 1

3. Loosen the range selection cable adjustment nuts.

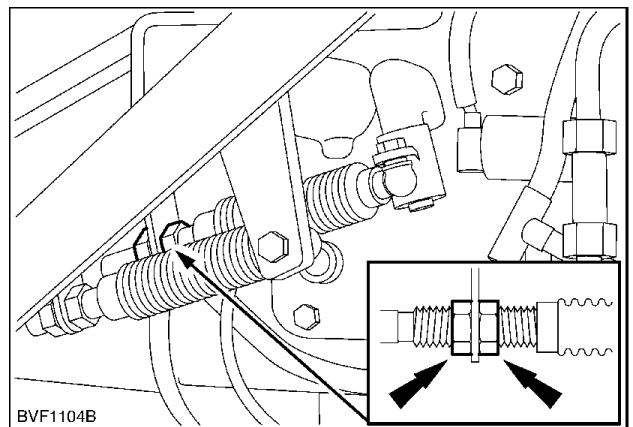

BVF1104B 2

4. Move the range selection cable (3) to remove the freeplay until the range lever in the cab is in the position shown.
Tighten the adjustment nut (1) to the bracket and tighten the adjustment nut (2).

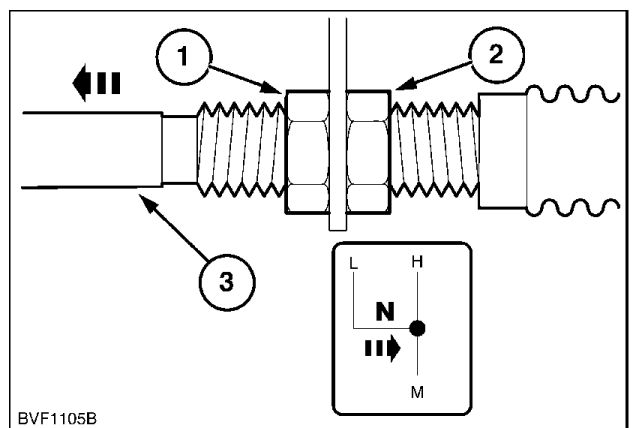

BVF1105B 3

31. Install the lubrication oil supply tube (1).

NOTICE: If the lubrication oil supply tube is not installed fully, lubrication oil flow into the transmission may be restricted.

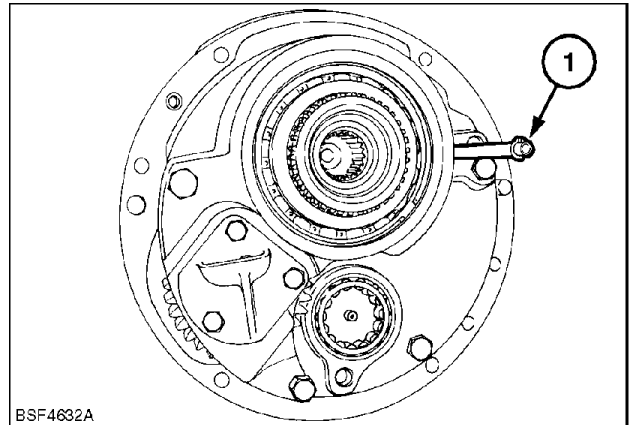

BSF4632A 31

Next operation:
Clutch Range clutch - Install (21.154)

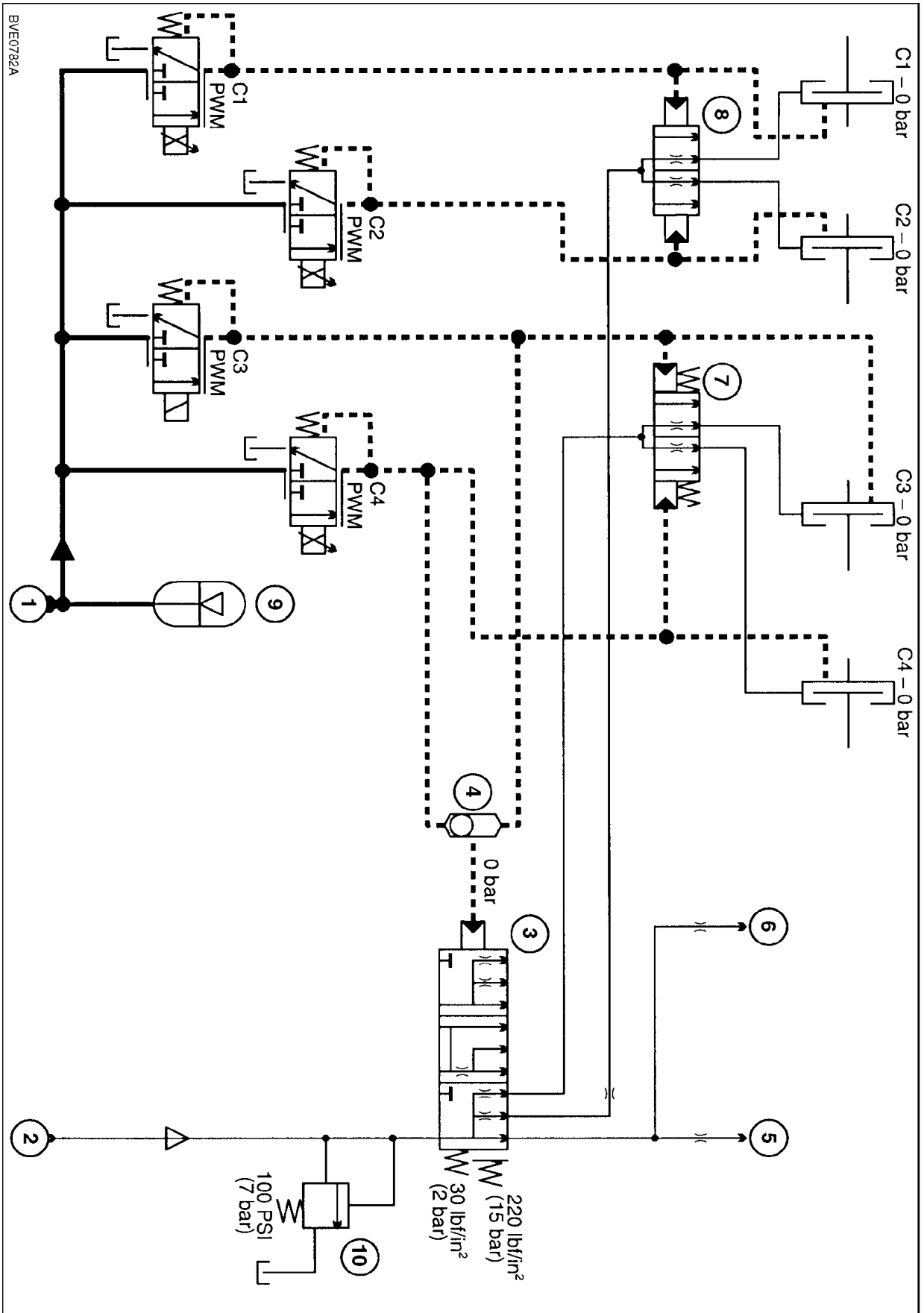

Transmission housing cover - Disassemble - Transmission Top Cover.

T6.120	NA
T6.140	NA
T6.150	NA
T6.155	NA
T6.160	NA
T6.165	NA
T6.175	NA

Prior operation:

Transmission housing cover - Remove (21.111).

1. Remove the two detent assemblies. **Transmission housing cover - Exploded view (21.111).**
2. Remove the two synchronizer position potentiometers, shaft housings and operating shafts.
3. Remove the four PWM solenoid valve assemblies.
4. Remove the 1-4/5-8 shift rail. Remove the circlip and the end cap of the forward/reverse rail. Loosen the shift fork retaining screws. Through the potentiometer housing orifice carefully pry the 1-4/5-8 shift rail from the top cover.
5. Remove the forward/reverse shift rail. Remove the circlip and the end cap of the forward/reverse rail. Loosen the shift fork retaining screws. Through the potentiometer housing orifice carefully lever the forward/reverse shift rail from the top cover.

Next operation:

Transmission housing cover - Visual inspection (21.111).

15. Assemble the clutch return spring assembly (4), onto the clutch housing and using a suitable hydraulic press (2), and spring compressor special tool 380001155 (1), compress the spring assembly and install the snap ring (3). Release the hydraulic press and remove the special tool. Repeat the above procedure for the second clutch.

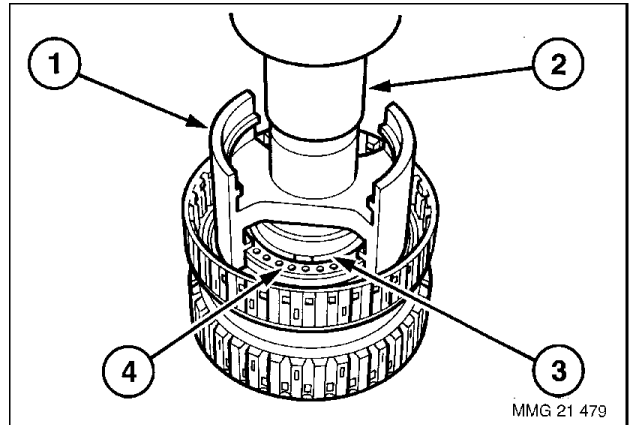

MMG 21 479 5

16. Check the piston oil seals by applying compressed air of not more than **3 bar (50 lbf/in²)** to the C2 clutch piston oil feed port (1) and the C1 clutch piston oil feed port (2). Make sure the pistons have no signs of leakage.

NOTE: Temporarily install the C1/C2 support manifold (2) to aid the application of compressed air. Coat the pistons with transmission oil to indicate any leakage.

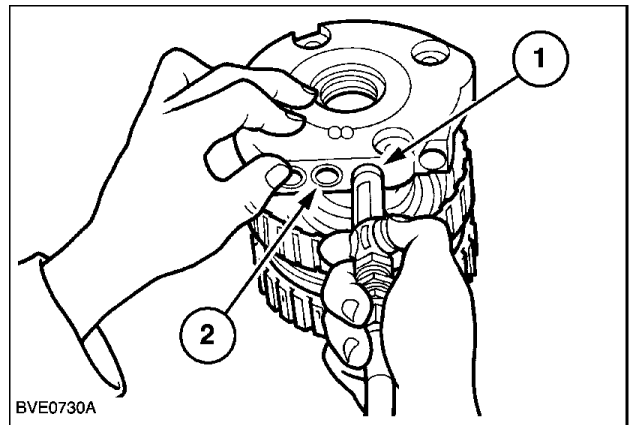

BVE0730A 6

C1/C2 Clutch Support Manifold Inspection and Assembly

17. Inspect the manifold (1) and adaptors (2) for wear or damage

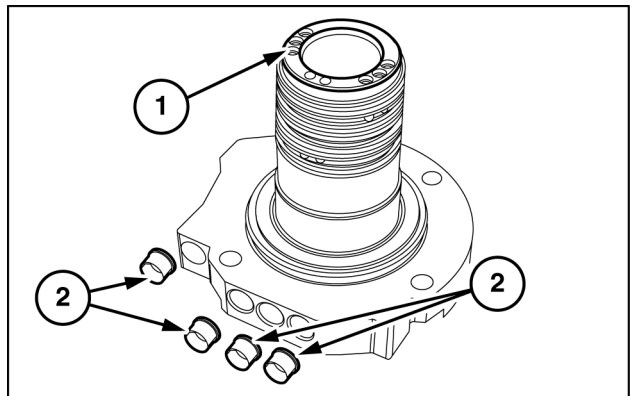

BAIL12APH210AAB 7

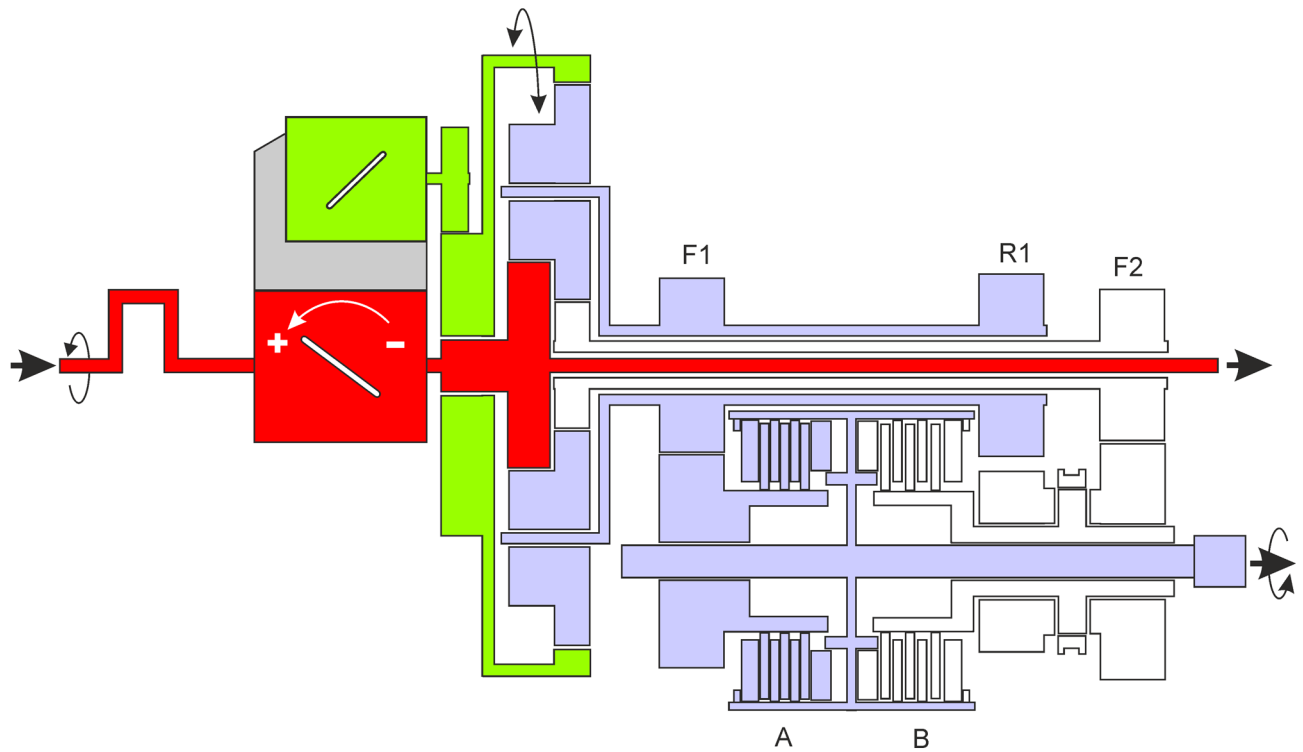

SS11K090 3

Gear F1

The drive train from the collecting planetary gear / planet carrier through the gear pair (**F1**) is connected to clutch (**A**). The swivel angle of the swash plate in the hydrostatic drive is turned toward the positive swivel angle (**+**) in order to increase the ground speed.

40. A. Install the battery (3).
B. Install the battery retaining bracket (2).
C. Connect the battery positive terminal (1).

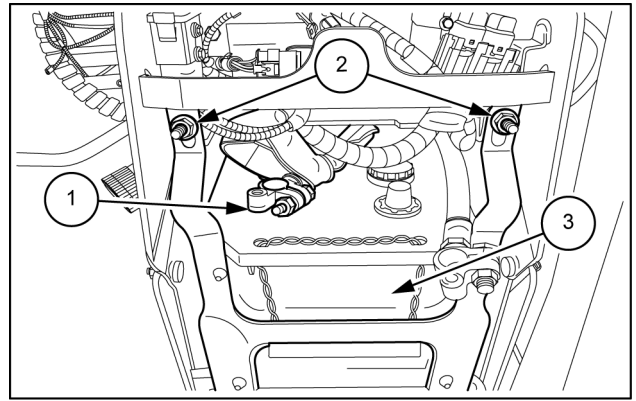

BAIL13TR01002AB 39

41. Install the cab right-hand steps.

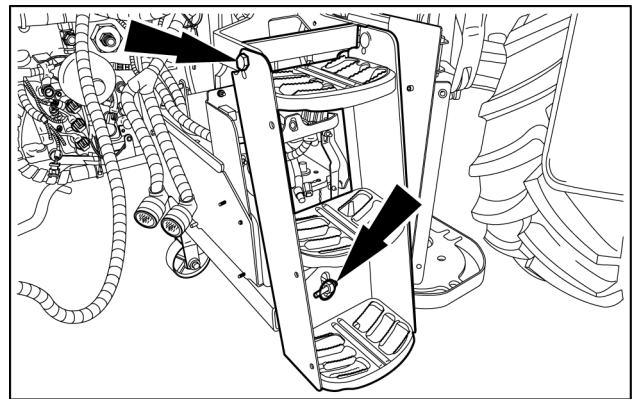

BAIL13TR01001AB 40

42. Install the brake pipes retaining bracket.

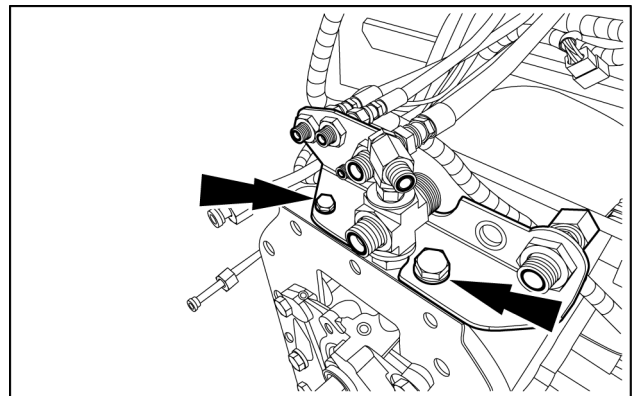

BAIL13TR01000AB 41

43. Install the hydraulic oil filter pipe.

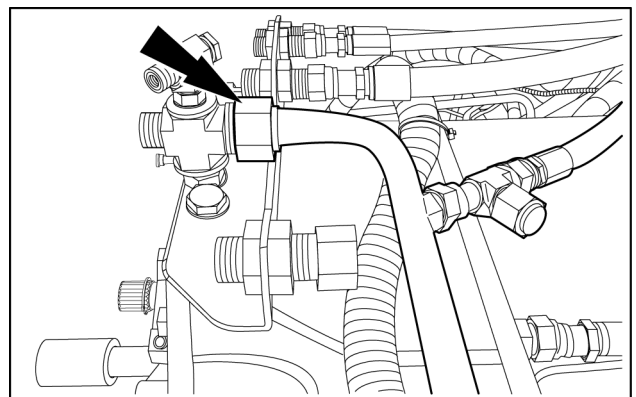

BAIL13TR00999AB 42

Next operation:

Connect the transmission to the rear axle, for further information refer to **Continuously Variable Transmission (CVT) - Connect (21.504)**

Hydrostat or hydrostatic unit - Install

T6.140 AutoCommand	NA
T6.150 AutoCommand	NA
T6.160 AutoCommand	NA

⚠ WARNING

Heavy objects!

Lift and handle all heavy components using lifting equipment with adequate capacity. Always support units or parts with suitable slings or hooks. Make sure the work area is clear of all bystanders. Failure to comply could result in death or serious injury.

W0398A

Continuously Variable Transmission (CVT) - Exploded view – Transmission input (21.504)

Prior operation:

Hydrostat or hydrostatic unit - Remove (21.507)

NOTICE: We recommend that you fill the hydrostat with oil via the G port (charge pressure port) before you install the hydrostat.

Use the recommended oil. refer to **Consumables Lubrications and Coolants ()**.

It is important to ensure that there is a charge pressure of at least **10 bar (145 psi)** at the G port during start-up (a delay of **5 - 6 s** is acceptable).

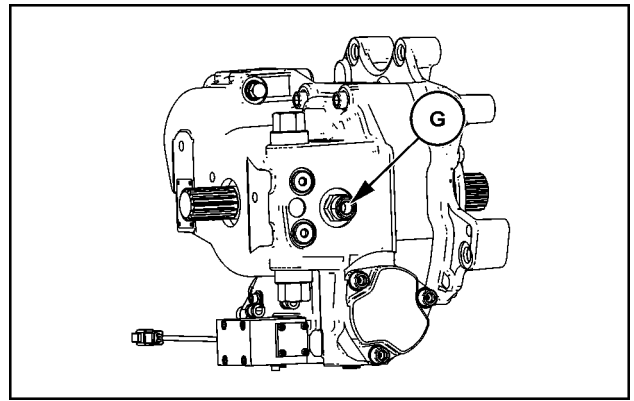

SS13K205 1

1. Install a new O-ring (**11**) on the hydrostat.

NOTE: Grease the O-ring with industrial Vaseline.

2. Insert the dowels (**15**) in the cover (**22**).

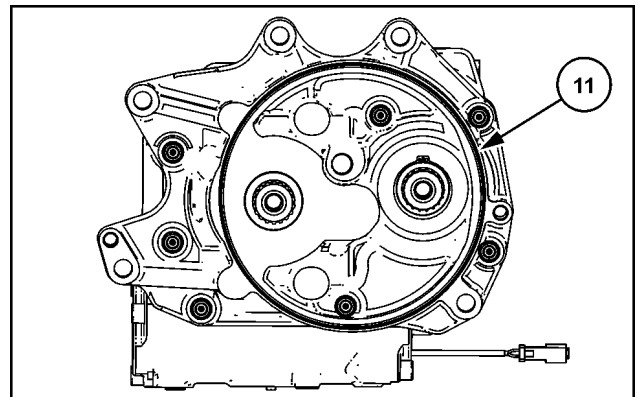

SS13G353 2

3. Install the studs **M16x1.5x100** at the indicated position.

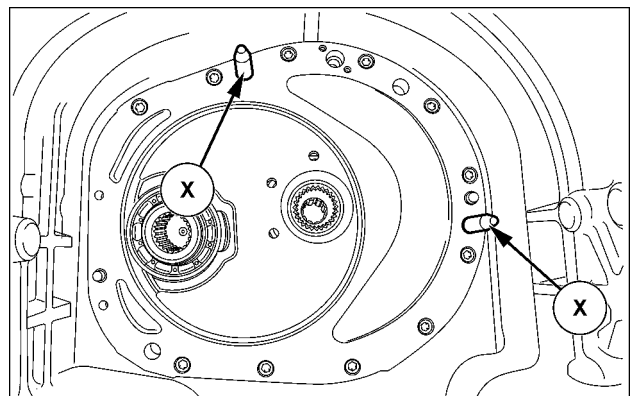

SS10F163 3

4. Remove the creeper status switches and the switch plungers.

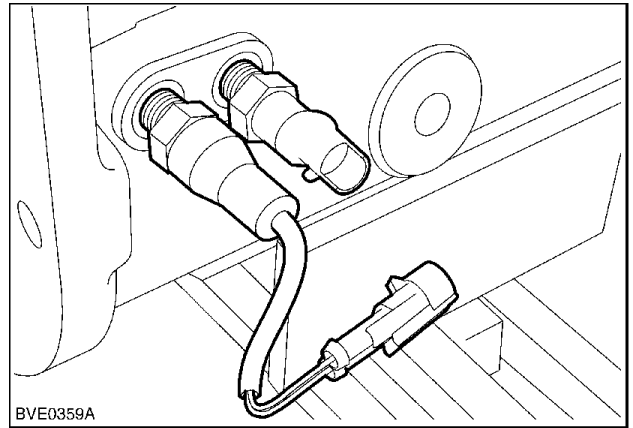

BVE0359A 4

5. Remove the creeper oil supply pipe (1).

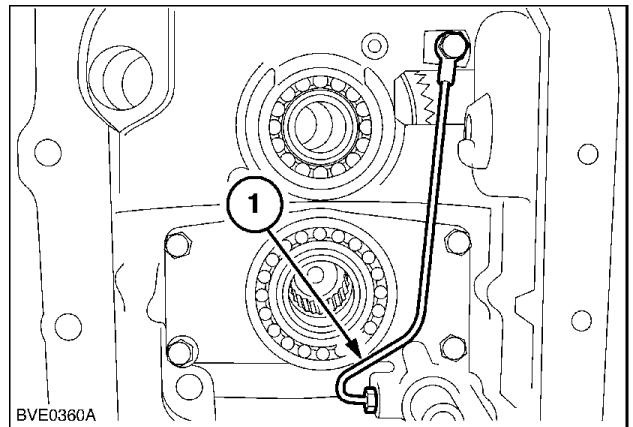

BVE0360A 5

6. Remove the creeper gear selector fork retaining bolt (1).

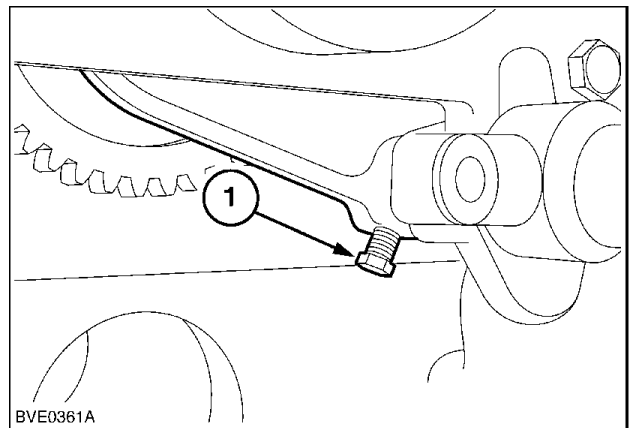

BVE0361A 6

7. Remove the creeper shaft and the bearing support bracket.

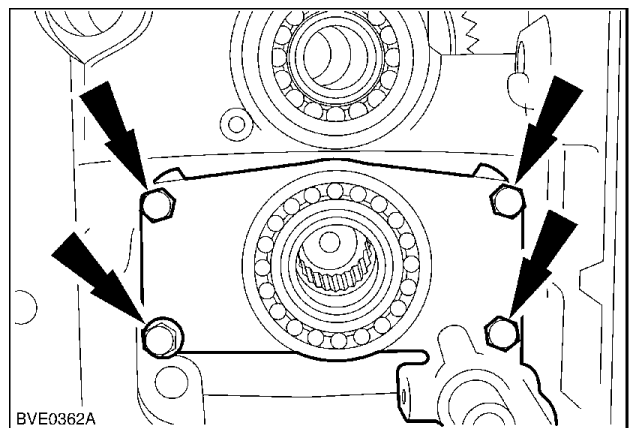

BVE0362A 7

Electro-hydraulic control - Static description

T6.120	NA
T6.140	NA
T6.150	NA
T6.155	NA
T6.160	NA
T6.165	NA
T6.175	NA

There are two types of four wheel drive transfer systems installed in the bottom of the rear axle housing, these are:

- Four wheel drive multi-wet plate clutch (16x16 transmission) - see **Front-Wheel Drive (FWD) clutch Multi-plate clutch - Sectional view (23.202)**.
- Four wheel drive dog clutch (24x24, 12x12, and 16x16 transmissions — Model dependant) - see **Front-Wheel Drive (FWD) clutch Dog clutch - Sectional view (23.202)**.

The four wheel drive is activated by the three position rocker switch **(1)** located in the cab on the right hand control console.

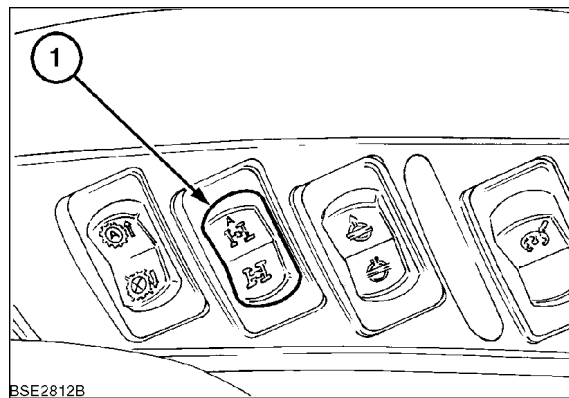

Manual Four Wheel Drive

When the rocker switch is in the manual four wheel drive position, four wheel drive is always engaged, regardless of the steering angle and tractor speed.

Automatic Four Wheel Drive

When the rocker switch is in the automatic four wheel drive position, four wheel drive will engage and disengage depending on the steering angle and tractor speed.

The disengagement steering angle and speed values can be changed using the diagnostic H routines, menu H3 - refer to **Electronic module - Configure (55.640)**.

Four Wheel Drive Off

NOTE: When the parking brake is applied, four wheel drive is engaged.

When the rocker switch is in the off position, four wheel drive is disengaged and will be engaged when both brake pedal are depressed, to provide four wheel braking.

The four wheel braking engagement speed can be changed using the diagnostic H routines, menu H3 - refer to **Electronic module - Configure (55.640)**.

NOTE: When four wheel drive is engaged and the key start is turned off, four wheel drive will be engaged when the key start is turned on again.



Front axle system - 25

Powered front axle - 100

**T6.120 , T6.140 AutoCommand , T6.140 , T6.150 AutoCommand , T6.150 ,
T6.155 , T6.160 AutoCommand , T6.160 , T6.165 , T6.175**

Axle support - Preload

T6. AutoCommand	NA
T6.120	NA
T6.140	NA
T6.150	NA
T6.155	NA
T6.160	NA
T6.165	NA
T6.175	NA

Supersteer™ Axle

1. Using suitable lifting equipment, remove the front weights.

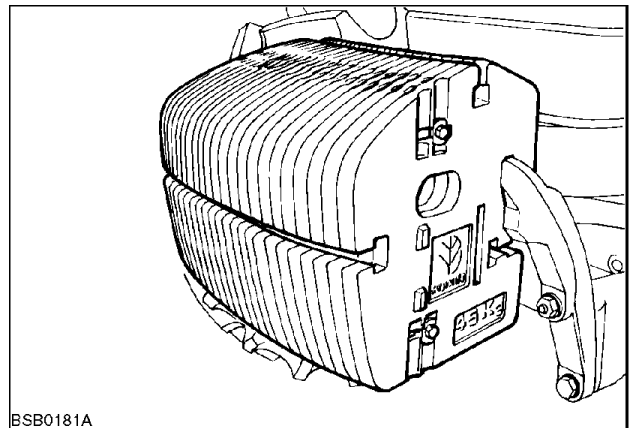

BSB0181A_353 1

2. Using suitable lifting equipment, remove the front weight carrier.

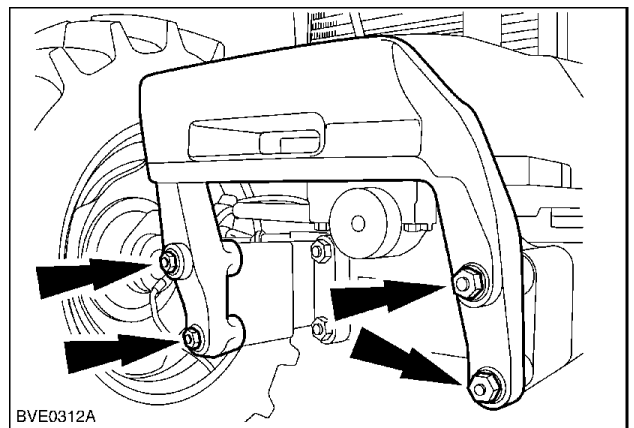

BVE0312A 2

3. Raise and support the front of the vehicle. Remove both front wheels.

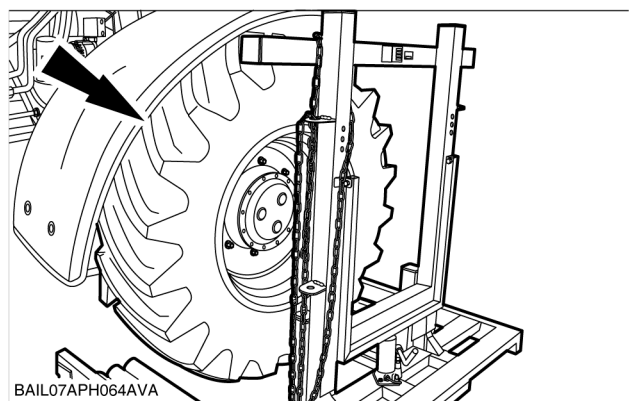

BAIL07APH064AVA 3

7. Using the previously recorded measurements calculate the required thickness of the bearing preload adjustment shim to obtain measurement **(S)**.

The bearing preload adjustment shim **(1)** will be calculated as follows:

$$(S) = L - L1 - C - G + 0.05\text{mm.}$$

For information on available shims refer to **Powered front axle - General specification (25.100)**.

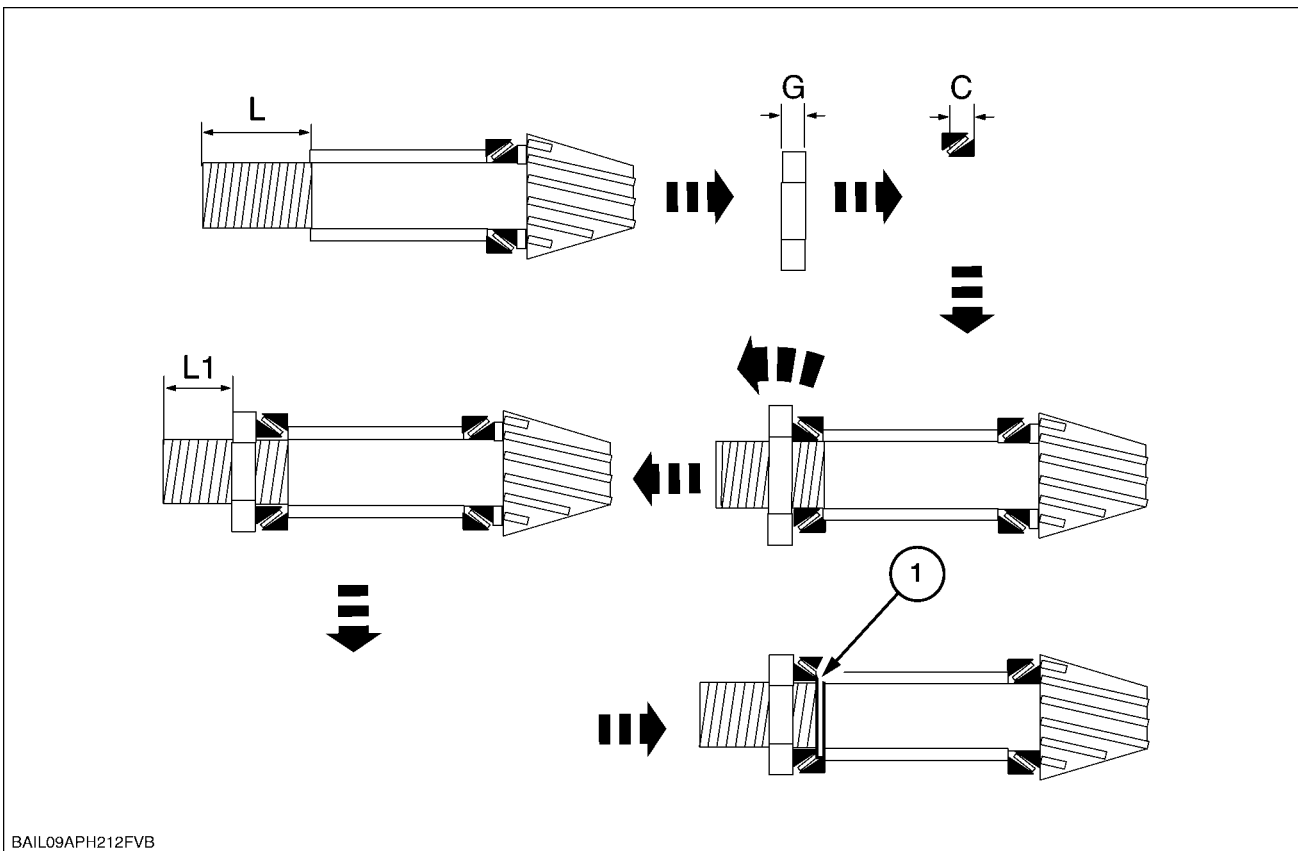

BAIL09APH212FVB 7

8. Remove the pinion shaft from the differential housing. Install the correct thickness preload adjustment shim **(1)** and reassemble the pinion shaft into the differential housing. Lubricate the bearings. Apply **LOCTITE® 243** to the pinion nut.

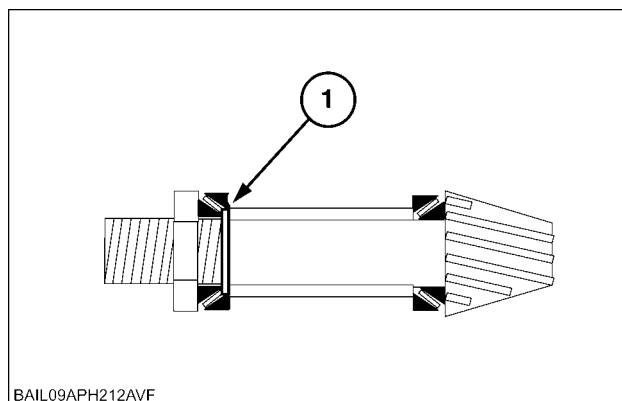

BAIL09APH212AVF 8

Axle shaft - Install

T6.120	NA
T6.140	NA
T6.150	NA
T6.155	NA
T6.160	NA
T6.165	NA
T6.175	NA

1. Install the axle shaft into the axle housing.

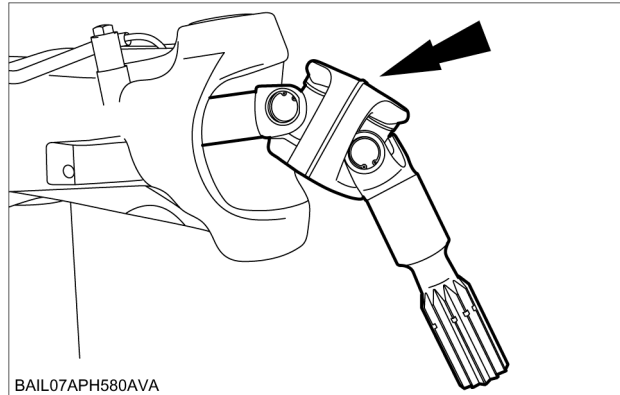

BAIL07APH580AVA 1

Next operation:

Install the hub, for further information refer to **Wheel hub - Install (25.108)**

Suspended axle control valve - Hydraulic schema

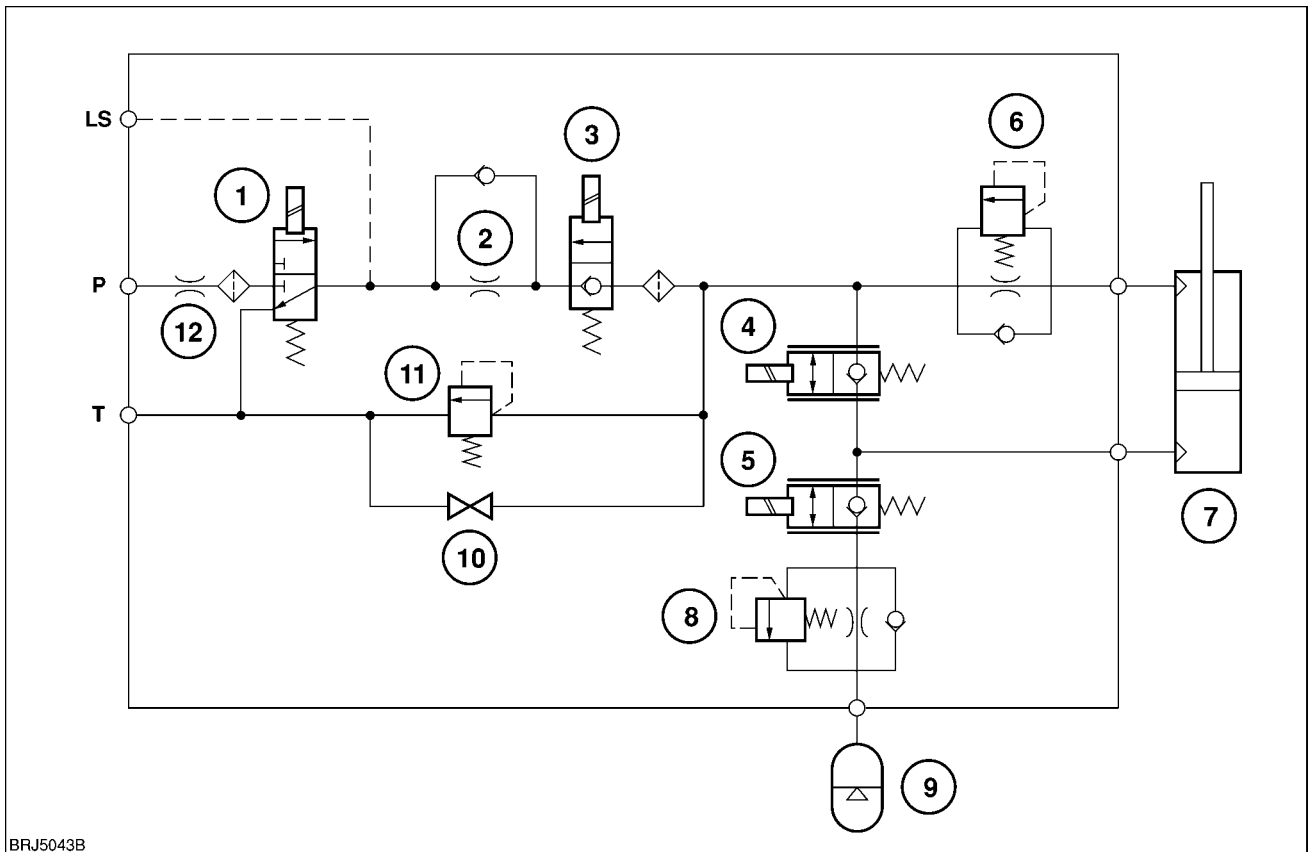

BRJ5043B

BAIL07APH371FSA 1

- | | | | |
|----|---------------------|----|-----------------------|
| 1 | Raise Coil | 2 | Lower Orifice |
| 3 | Lower Coil | 4 | Lockout Coil #3 |
| 5 | Lockout Coil #4 | 6 | Rebound Discpack |
| 7 | Suspension Cylinder | 8 | Compression Discpack |
| 9 | Accumulator | 10 | Manual Override Screw |
| 11 | Relief Valve | 12 | Raise Orifice |

28. Install the static part of the tractor splitting stand **380003352** under the rear axle.

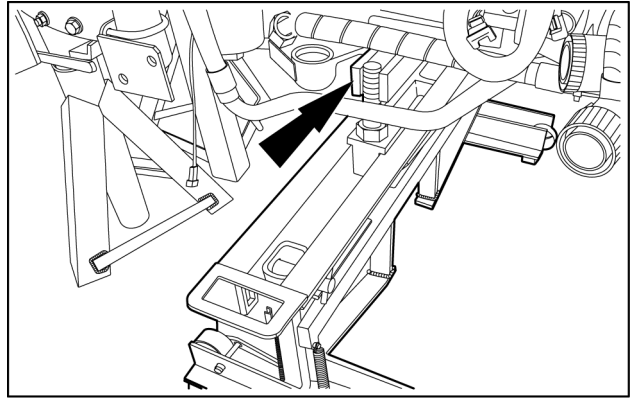

BAIL13TR00978AB 27

29. Install the static part of the tractor splitting stand **380003352** under the rear axle.

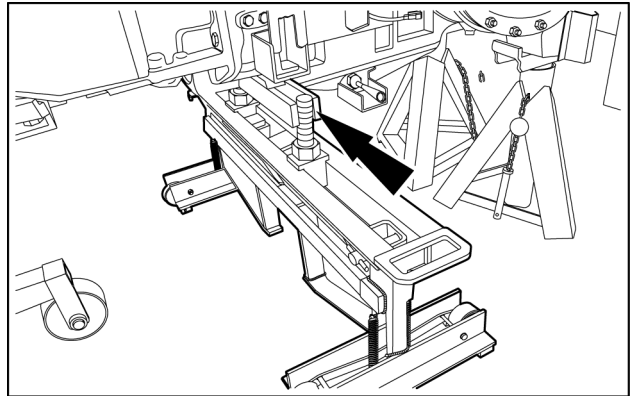

BAIL13TR00979AB 28

Vehicles with SuperSteer™ front axle

30.

1. Remove the front-wheel drive shaft guard retaining bolts.
2. Remove the front wheel drive shaft guard.

NOTE: Repeat operation 1 on both sides of the vehicle.

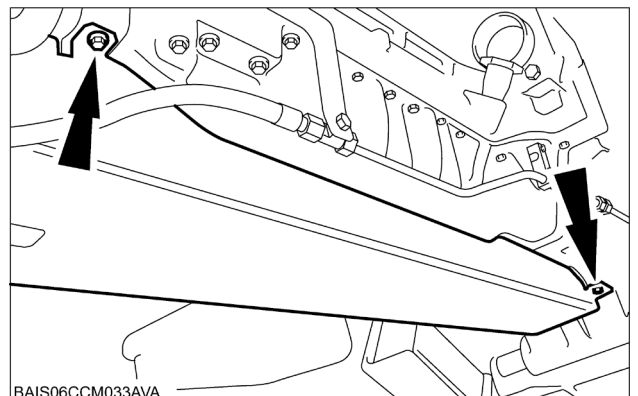

BAIS06CCM033AVA

BAIS06CCM033AVA 29

31. Remove the front-wheel drive shaft front retaining bolts.

NOTE: Support the front-wheel drive shaft.

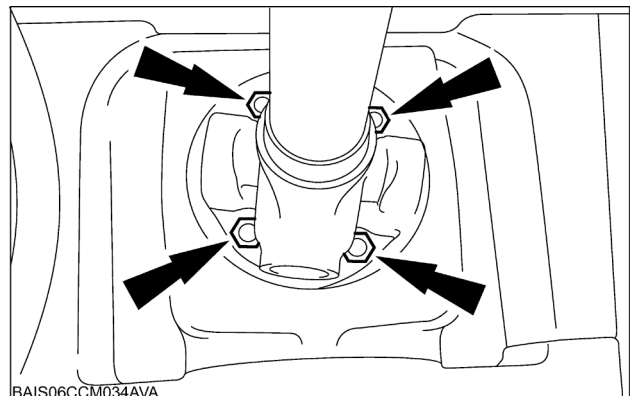

BAIS06CCM034AVA

BAIS06CCM034AVA 30

7. Install Special tool **380001113** and connect it to a hoist. Remove the final drive case to rear axle housing retaining nuts and remove the final drive assembly together with the half-shaft.

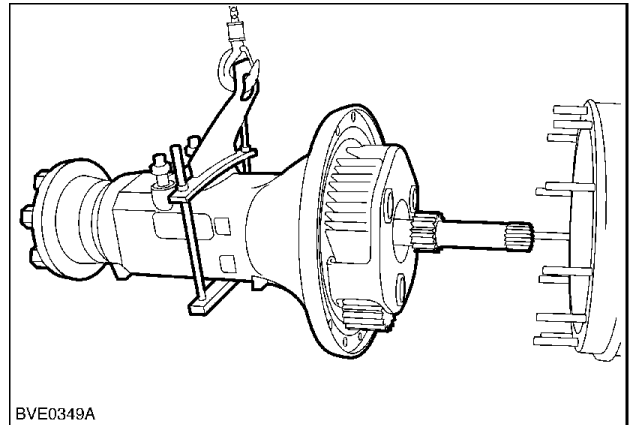

BVE0349A 7

8. Remove the outer ring gear (1), steel plate (2) and friction disc (3).

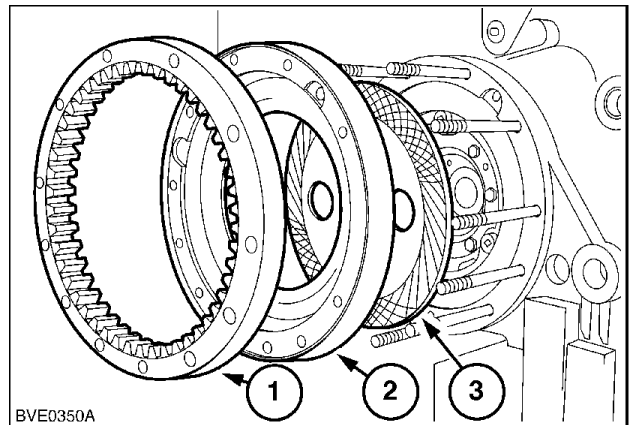

BVE0350A 8

Next operation:
Planetary final drive - Disassemble (27.120)

Three-speed rear Power Take-Off (PTO) - Torque

T6. AutoCommand	NA
T6.120	NA
T6.140	NA
T6.150	NA
T6.155	NA
T6.160	NA
T6.165	NA
T6.175	NA

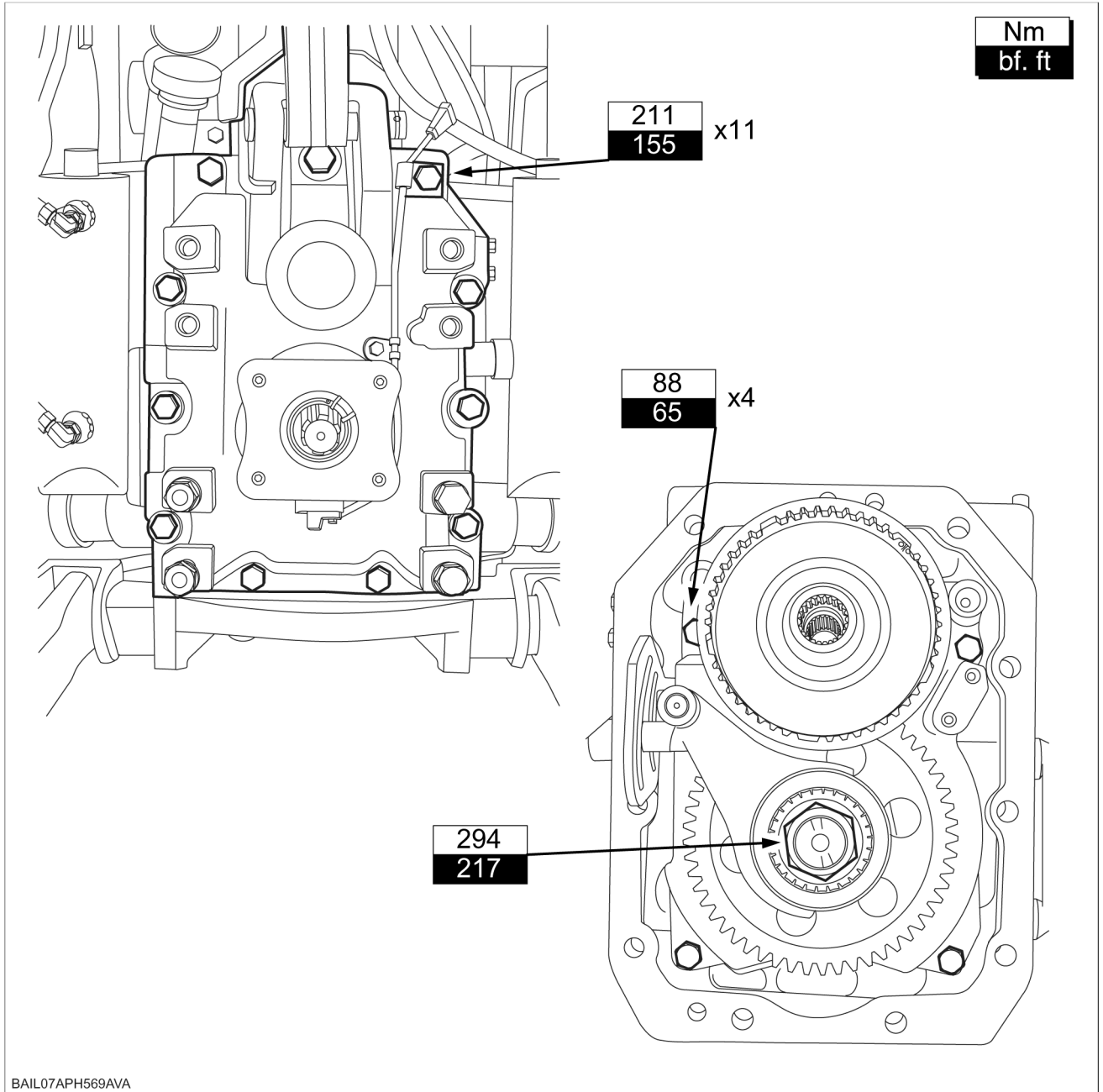

BAIL07APH569AVA 1

Front Power Take-Off (PTO) - Static description

T6. AutoCommand	NA
T6.120	NA
T6.140	NA
T6.150	NA
T6.155	NA
T6.160	NA
T6.165	NA
T6.175	NA

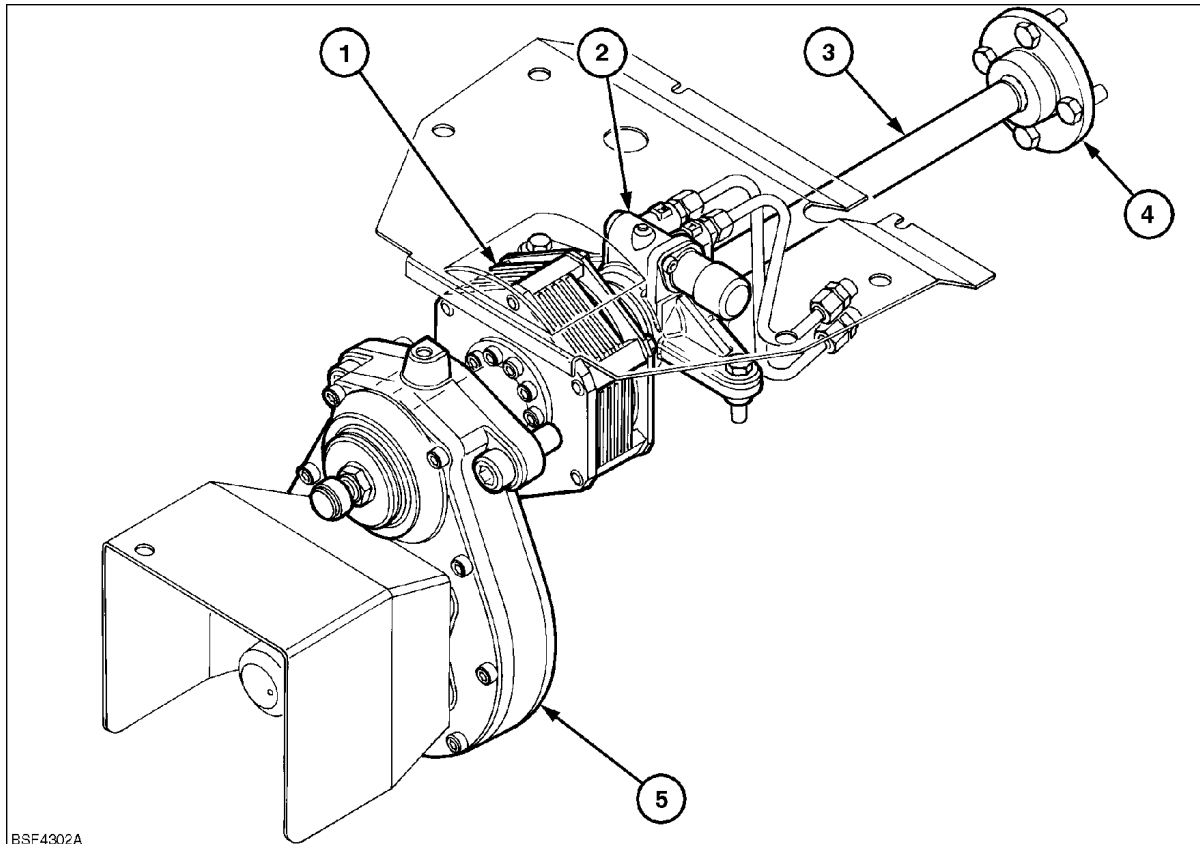

BSF4302A

BSF4302A 1

Front PTO

- | | |
|------------------------------|------------------------------------|
| 1 PTO multi-dry plate clutch | 2 PTO control housing |
| 3 PTO input shaft | 4 Engine crankshaft pulley coupler |
| 5 PTO reduction gearbox | |

The front PTO is engaged/disengaged by the piston control housing (2). The PTO is driven directly from the engine crankshaft. The engine crankshaft pulley coupler (4) transfers drive through the PTO input shaft (3) and into the multi-dry plate clutch (1). When the PTO is engaged the drive is transferred through the multi-dry plate clutch (1) into the PTO reduction gearbox (5) to the PTO reduction gearbox output shaft.

Parking brake disks - Overhaul Park Brake

T6.140 AutoCommand	NA
T6.150 AutoCommand	NA
T6.160 AutoCommand	NA

Prior operation:

Remove the fuel tank, for further information refer to **Fuel tank - Remove (10.216)**

Prior operation:

Inhibit the Electronic Park Lock (EPL), for further information refer to **Electronic park lock actuator/controller - Adjust (55.031)**.

1. Remove the drain plug and drain the transmission oil into a suitable container. Install the drain plug once the oil has drained.
Tighten to **68-82 Nm (50-60 lb ft)**.

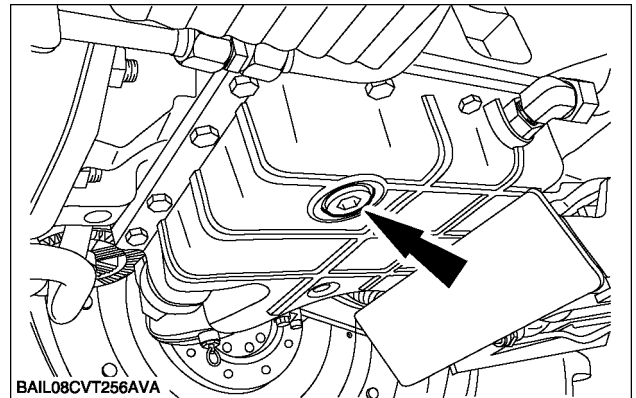

BAIL08CVT256AVA 1

2. Detach the parking brake cable.
 - A. Remove the clevis pin (1).
 - B. Remove the retaining clip (2).

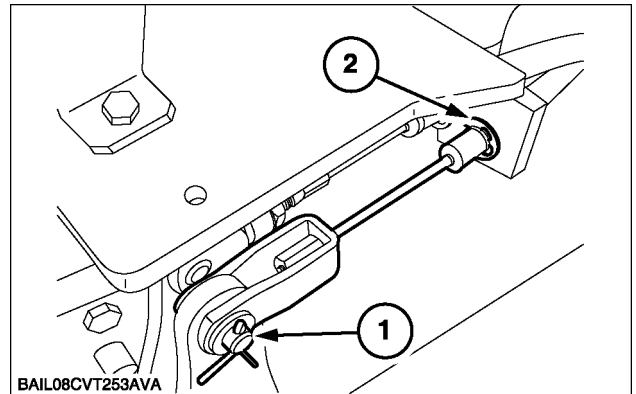

BAIL08CVT253AVA 2

3. Detach the EPL cable.
 - A. Remove the speed clip (1).
 - B. Remove the retaining clip (2).

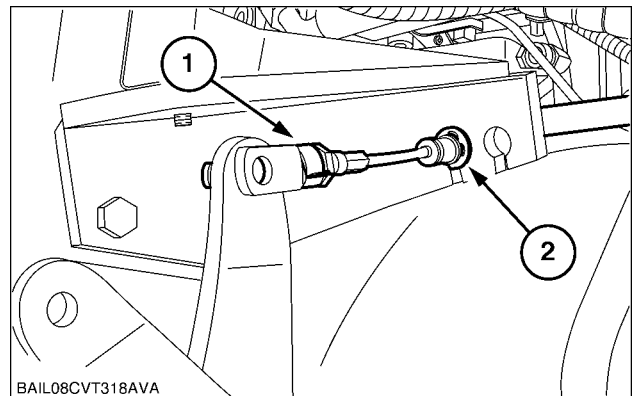

BAIL08CVT318AVA 3

Trailer brake valve - Remove (Solenoid valve block Italian Trailer brake)

T6. AutoCommand	NA
T6.120	NA
T6.140	NA
T6.150	NA
T6.155	NA
T6.160	NA
T6.165	NA
T6.175	NA

1. Disconnect the trailer brake solenoid valve block electrical connectors.
2. Disconnect the trailer brake valve oil supply pipe (1).

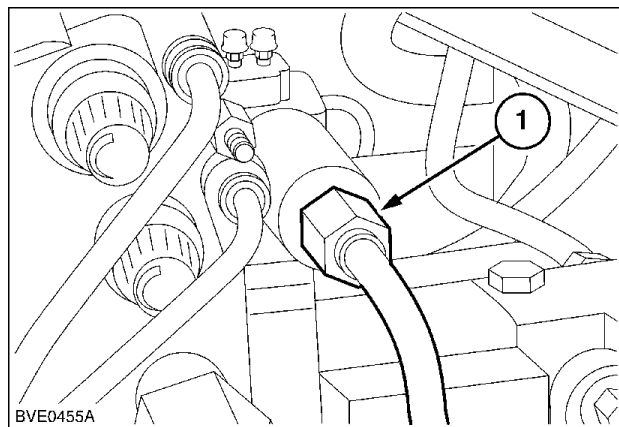

BVE0455A 1

3. Disconnect the oil supply pipe (1) from the quick release coupling and remove the banjo retaining bolt (2) from the Italian trailer brake solenoid valve block.

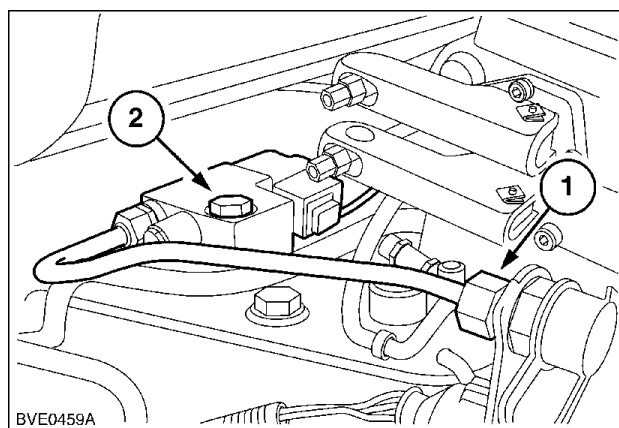

BVE0459A 2

4. Remove the Italian trailer brake solenoid valve block with the oil supply pipes attached.
5. Remove the oil supply pipes from the Italian trailer brake solenoid valve block.

Next operation:

Trailer brake valve - Install (33.220)

Trailer brake pneumatic control - Troubleshooting

T6. AutoCommand	NA
T6.120	NA
T6.140	NA
T6.150	NA
T6.155	NA
T6.160	NA
T6.165	NA
T6.175	NA

Problem	Possible Cause	Correction
System pressure too high (exceeds 13.5 bar (195.8 psi))	Faulty unload valve in air processing unit.	Remove valve clean/replace refer to Trailer brake pneumatic control - Remove (33.224) .
Delay in trailer brake operation	Dual line solenoid failed closed or permanently energised.	Disconnect wiring to solenoid. If brakes operate normally inspect wiring for short to +12 v . If still a delay in operation after wire disconnection replace solenoid assembly. Faulty brake switch
Instrument cluster light illuminates when system is running.	System pressure below 4.5/3.5 bar .	Compressor drive belt broken Check system for leaks Unload valve failed, stuck open Compressor fault Reservoir drain tap faulty
	Faulty switch or switch wiring	Disconnect wiring to switch. If light extinguishes replace switch. If light remains illuminated check wiring for short to earth.
Trailer brakes not functioning (system air pressure okay)	Air in hydraulic braking system	Bleed brakes. Refer to Hydraulic service brakes - Bleed (33.202)
	Faulty pilot valve	Disconnect supply line to control valve from pilot valve assembly. Operate the brakes, if oil is expelled, pilot valve is okay. If no oil expelled remove and inspect pilot valve.
	Control valve faulty	Repair/replace as required
System pressure too high (exceeds 12 bar +/- 2)	Faulty Relief valve	Remove valve clean/replace. refer to Trailer brake pneumatic control - Remove (33.224)

11. Remove the oil filter.

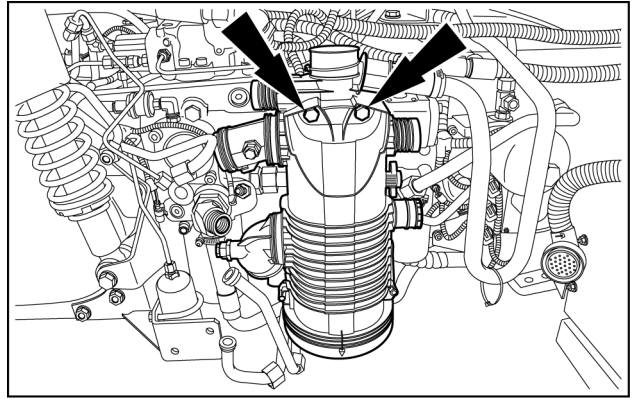

BAIL13TR00945AB 11

Charge pump - General specification

T6. AutoCommand	NA
T6.120	NA
T6.140	NA
T6.150	NA
T6.155	NA
T6.160	NA
T6.165	NA
T6.175	NA

Type	Rotor Pump
Displacement	57 cm³/rev (3.48 in³/rev)
Output (new pump) @ 2200 RPM (enginespeed)	143 l/min (31.5 UK gpm) 37.8 US gpm
Charge Pressure Filter Dump Valve	Open @ 6 bar (87 psi)
Charge Pressure Limiting Valve	Open @ 1.72 bar (24.9 psi)
Charge Pressure Switch (making charge pressure warning light flash)	Close @ 0.55 - 0.82 bar (8 - 11.9 psi)

Type	Rotor Pump
Displacement	74.0 cm³/rev (4.5 in³/rev)
Output (new pump) @ 2200 RPM (enginespeed)	163.0 l/min (43.1 US gpm)
Charge Pressure Filter Dump Valve	Open @ 10.0 bar (145.0 psi)
Charge Pressure	2.0 - 4.0 bar (29.0 - 58.0 psi)
Charge Pressure Switch (making charge pressure warning light flash)	Close @ 1.0 bar (14.5 psi)

Electro-hydraulic control valve - Static description

The remote valves are a stack type design clamped together with the hydraulic lift electronic draft control valve . The stack assembly also incorporates the low pressure regulating and priority valve . Each remote valve has its own built in microprocessor which controls the oil flow through a solenoid activated valve, based on inputs received from the operator controlled switches.

Each remote valve is connected into the electrical CAN BUS system to the U1 control module, located behind the drivers seat. Each remote valve can also detect system faults and send a message to the U1 module which in turn sends a signal to allow a fault code to be displayed on the instrument cluster.

A list of fault codes and the fault finding charts can be found in **Electronic module - Fault code index (55.640)**.

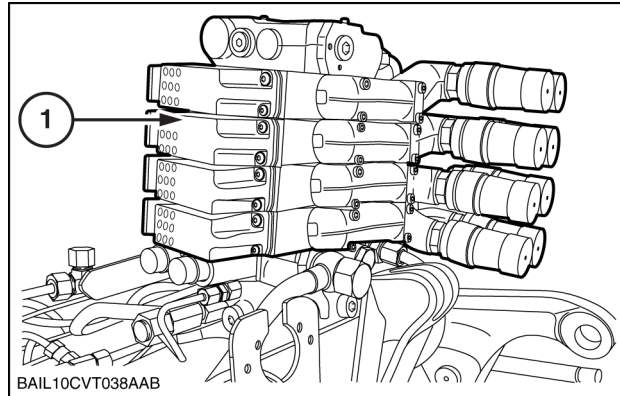

BAIL10CVT038AAB 1

Control Levers

The electro-hydraulic remote valves are operated by control levers in the right-hand console. Each control lever is coloured to correspond to the colour on the remote valve. A maximum of four electro-hydraulic remote valves may be fitted.

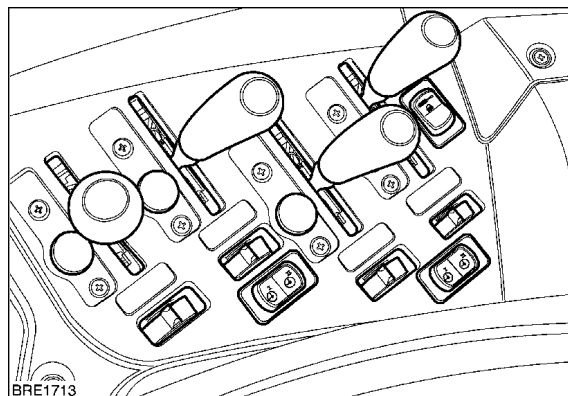

BRE1713 2

- 1 Control lever I Green
- 3 Control lever III Brown

- 2 Control lever II Blue
- 4 Control lever IV Black

The remote valve control levers have four positions: neutral, extend, retract, and float.

Pull the lever back from the neutral position, to the "extend" (raise) position. From neutral, push forward to the "retract" (lower) position. Push the lever fully forward to the float position. Float will permit the cylinder to extend or retract allowing equipment such as scraper blades to "float" or follow the ground contour.

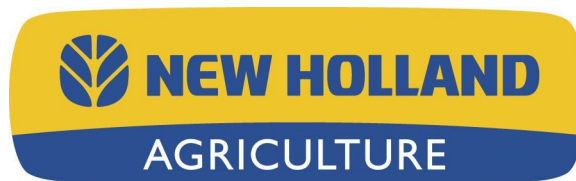

Hydraulic systems - 35

Three-point hitch cylinder - 116

**T6.120 , T6.140 AutoCommand , T6.140 , T6.150 AutoCommand , T6.150 ,
T6.155 , T6.160 AutoCommand , T6.160 , T6.165 , T6.175**



Steering - 41

Steering control - 101

**T6.120 , T6.140 AutoCommand , T6.140 , T6.150 AutoCommand , T6.150 ,
T6.155 , T6.160 AutoCommand , T6.160 , T6.165 , T6.175**

4. Install 'O' ring seals to the control valve. Connect the four supply/return hoses.

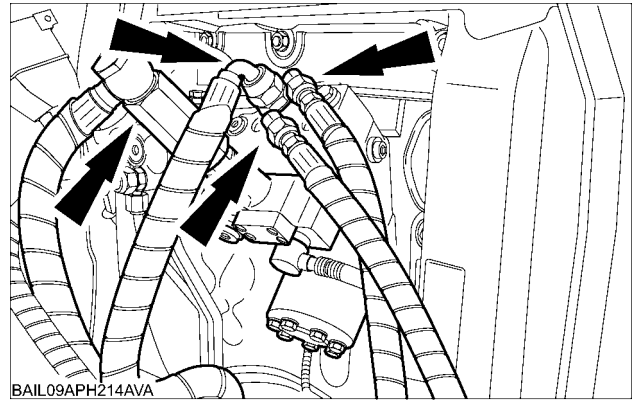

BAIL09APH214AVB 3

5. Reposition and attach the brake fluid reservoir.
6. Reposition the processor harness.

Next operation:

Install the steering column, for further information refer to **Steering column - Install (41.101)**

Next operation:

Connect the battery, for further information refer to **Battery - Connect (55.302)**



Cab climate control - 50

Ventilation - 104

**T6.120 , T6.140 AutoCommand , T6.140 , T6.150 AutoCommand , T6.150 ,
T6.155 , T6.160 AutoCommand , T6.160 , T6.165 , T6.175**

9. If the gap size is not achieved, adjusting shims must be added or removed until the prescribed gap size is achieved.

NOTE: New shims are available in sizes **1.00, 0.50 - 0.13 mm, (0.040, 0.020 - 0.005 in)**.

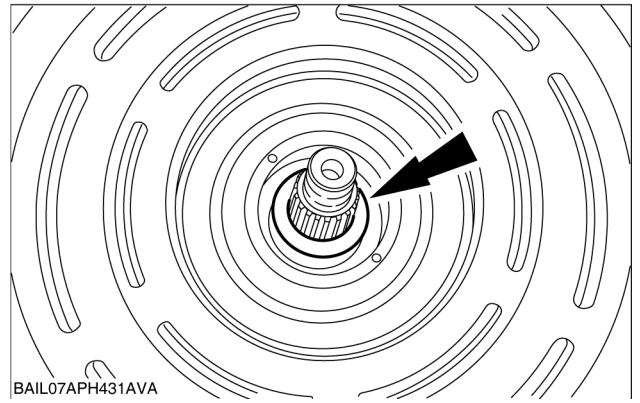

BAIL07APH431AVA 8

10. Attach the cover to the coupling plate and fit the screws.

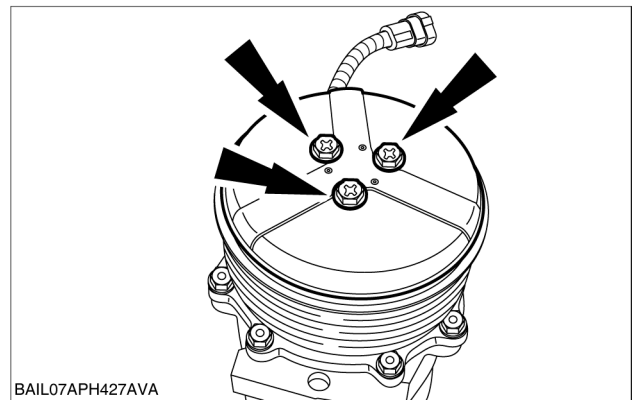

BAIL07APH427AVA 9

Next operation:
Air-conditioning compressor - Install (50.200)

Electrical systems - Harnesses and connectors

No.	Amps	Circuit
F-054	10	Power supply PTO rear
F-055	10	Supply Ignition FastSteer™ , A/C pressure switch, Auto Guidance , Rear Hitch Switch, EHR External Switch Fender
F-056	15	Power Supply, PTO front, Armrest Unit, Electro Hydraulic Remote (EHR) control valves
F-057		Not used
F-058		Not Used
F-059		Not Used
F-060	10	Timer relay battery isolator, Battery isolator control switch
F-061	5	Power supply Universal Controller (UCM)
F-062		Not Used
F-063	10	Power supply Universal Controller (UCM)
F-064	20	Power supply Universal Controller (UCM)
F-065	7,5	Power supply Universal Controller (UCM)
F-066	10	Power supply Universal Controller (UCM)
F-067	10	Power supply Universal Controller (UCM)
F-068	10	Power supply Universal Controller (UCM)
F-069	10	Power supply Universal Controller (UCM)
F-070	5	Power supply Universal Controller (UCM)
F-091	10	Less Battery Isolator
F-092	10	with Battery Isolator

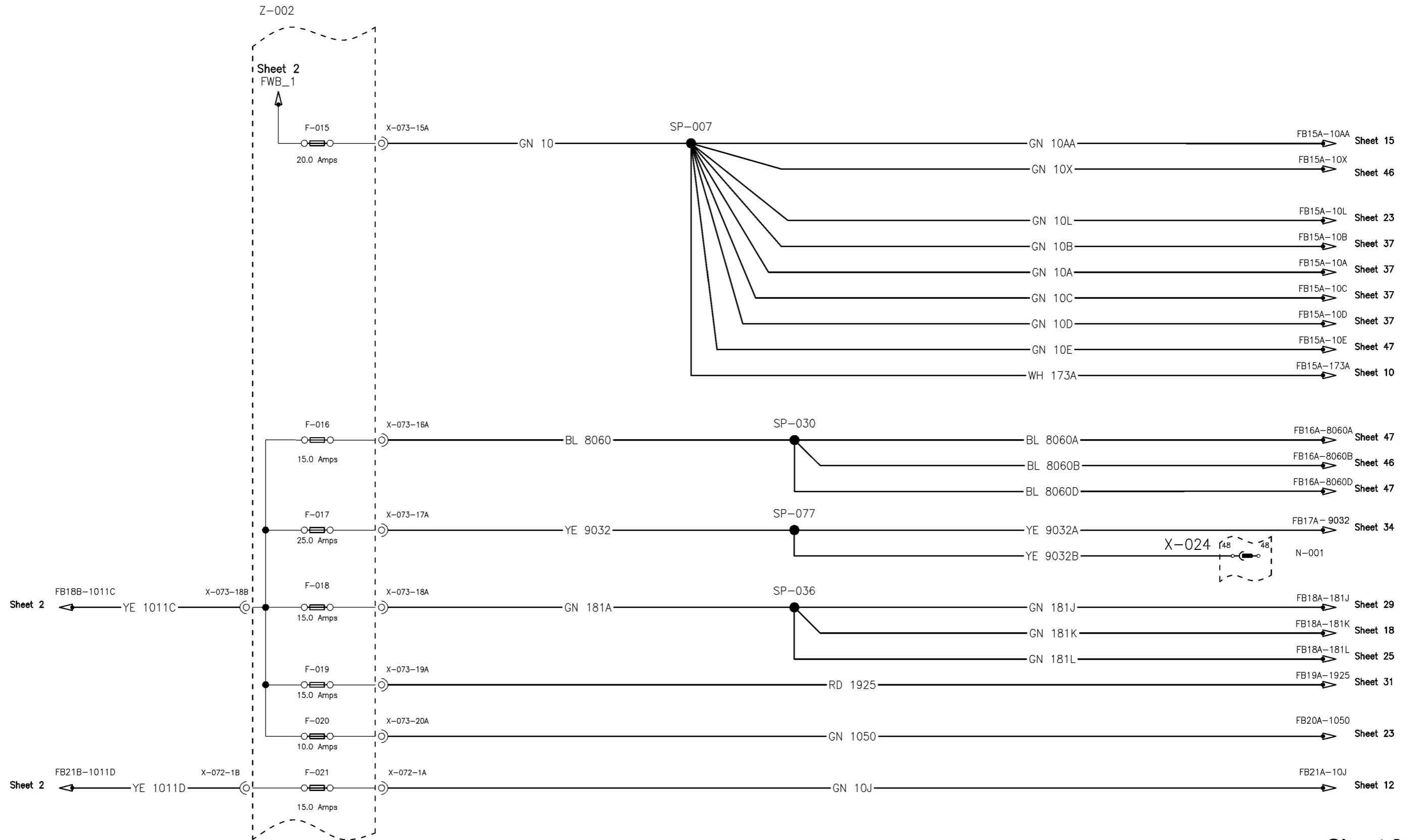

Sheet 3

SS11J082 1

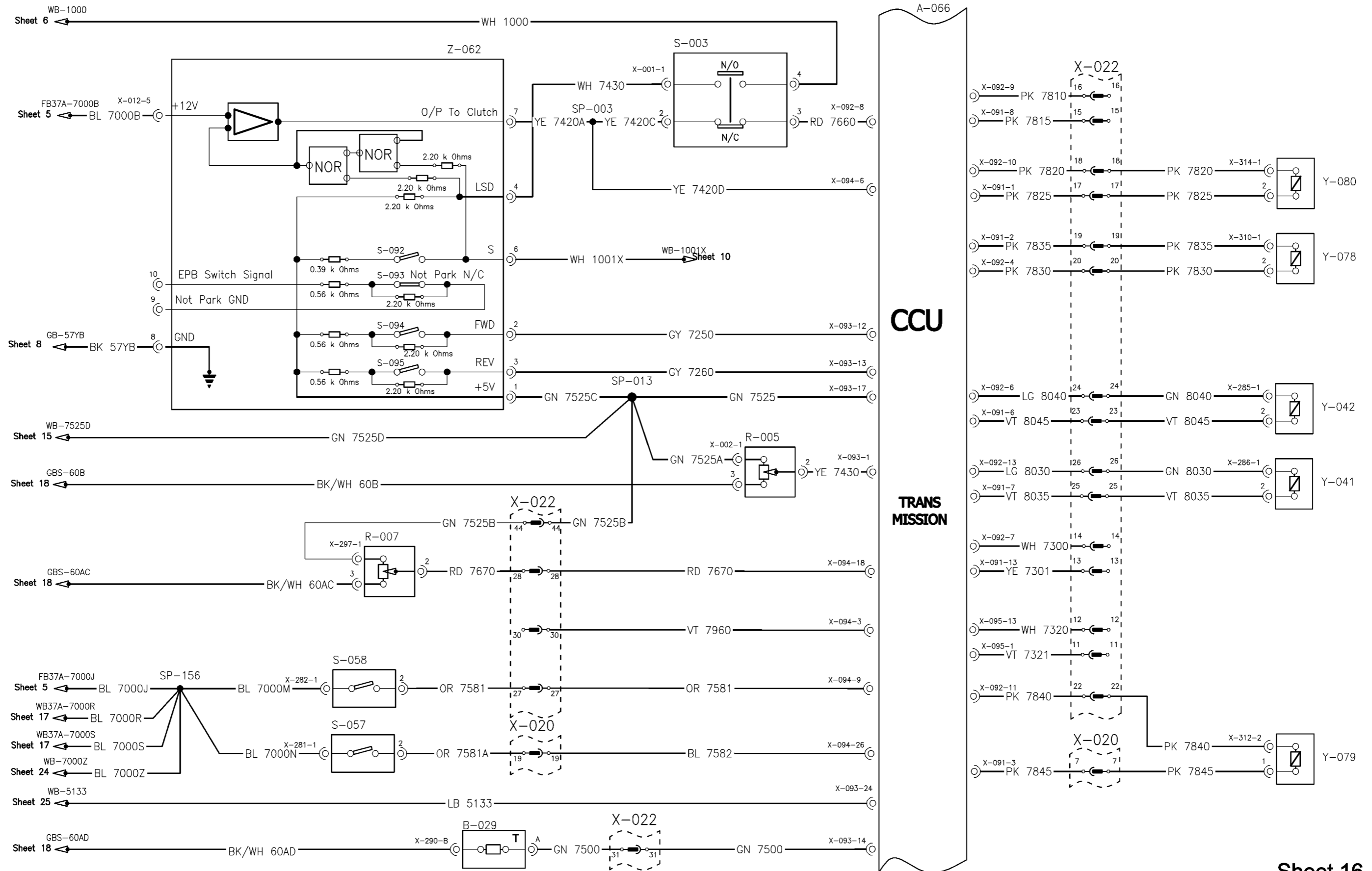

Sheet 16

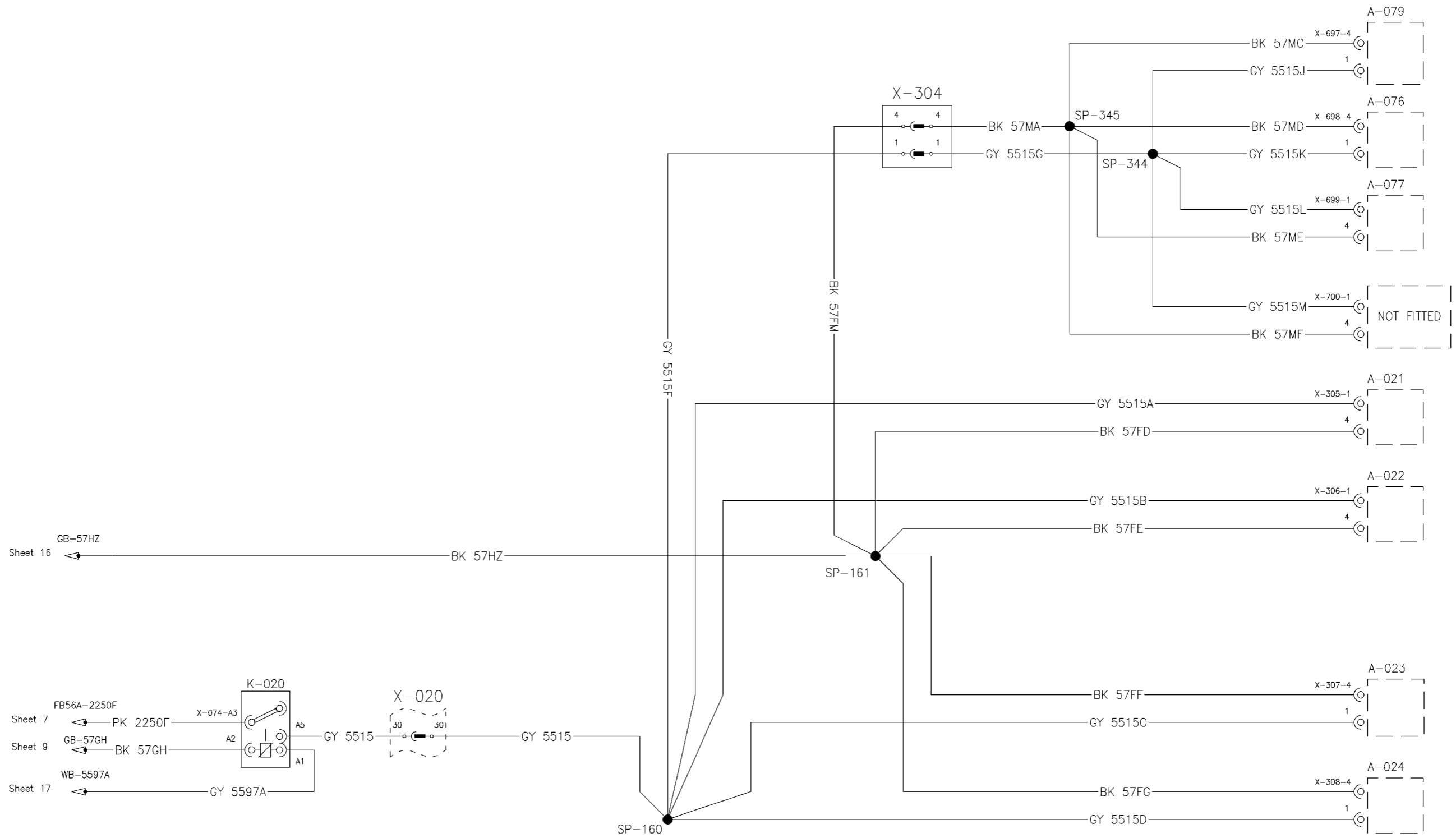

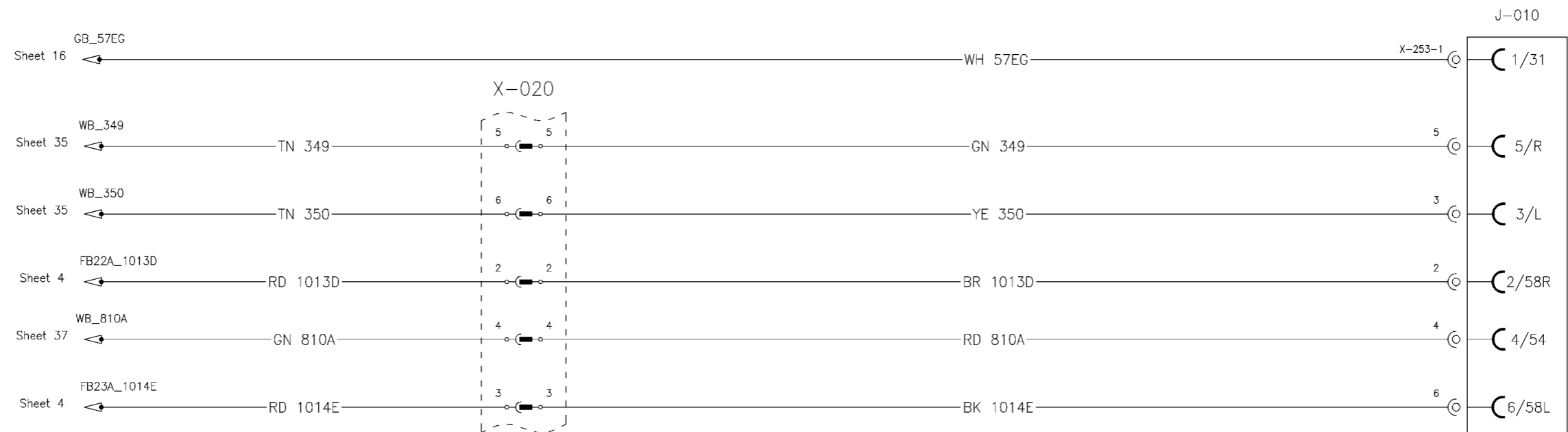

T6.120 - 175

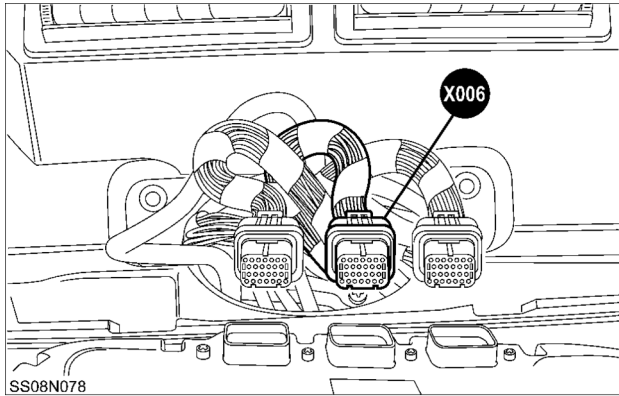

SS08N078 15

BEHIND INSTRUMENT CLUSTER

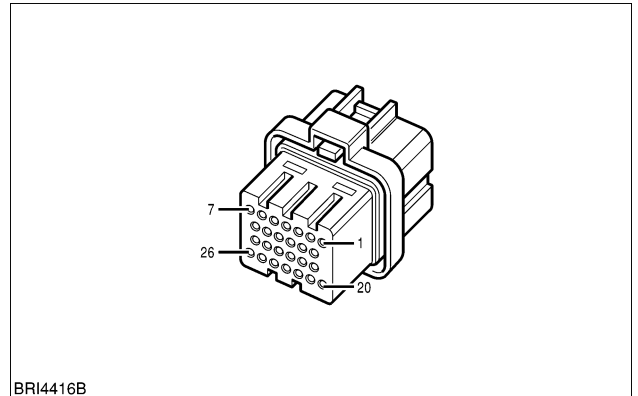

BRI4416B-01 16

X007 Hazard Switch Harness

POS.	COLOR	WIRE NUMBER	CIRCUIT REFERENCE
1	VT	1021	HAZARD SWITCH SUPPLY (BATTERY)
2	GN	1020	HAZARD SWITCH SUPPLY
3	BK	57	EARTH (ALL)
4	GN	1020	HAZARD SWITCH SUPPLY

NOTE: For the wiring color code refer to, *Wire harnesses - Identification (55.100)*.

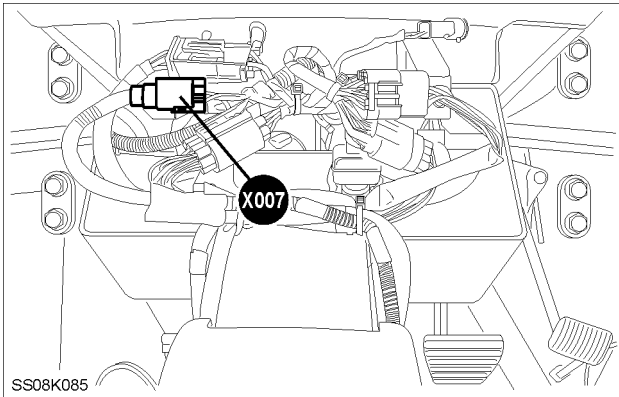

SS08K085 17

STEERING CONSOLE

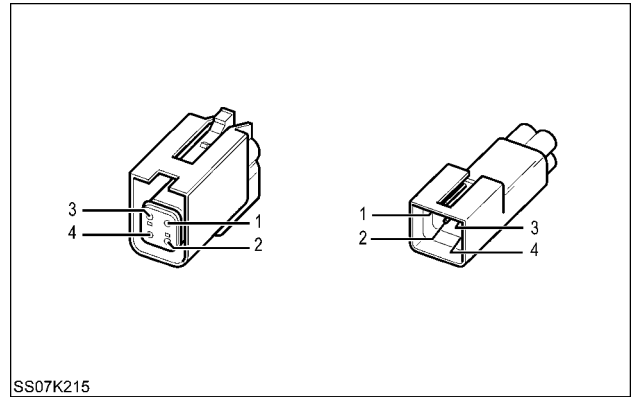

SS07K215 18

X008 Instrument cluster keypad

POS.	COLOR	WIRE NUMBER	CIRCUIT REFERENCE
1	GN	1050	ACCESSORY FEED
2	GN	5420	CAN L
3	YE	5400	CAN H
4	BK	61	CASE GROUND

NOTE: For the wiring color code refer to, *Wire harnesses - Identification (55.100)*.

T6.140 - 160 AutoCommand

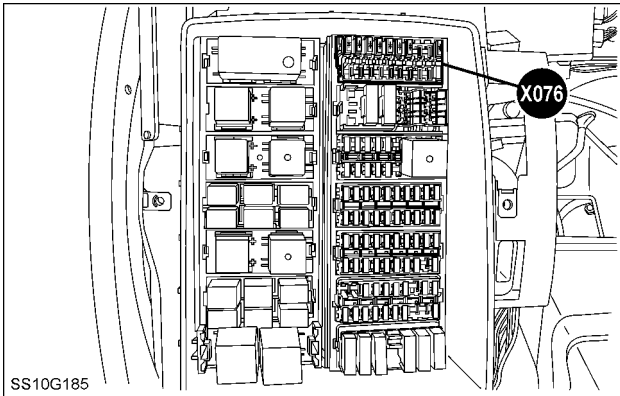

SS10G185 33

FRONT RIGHT HAND CAB

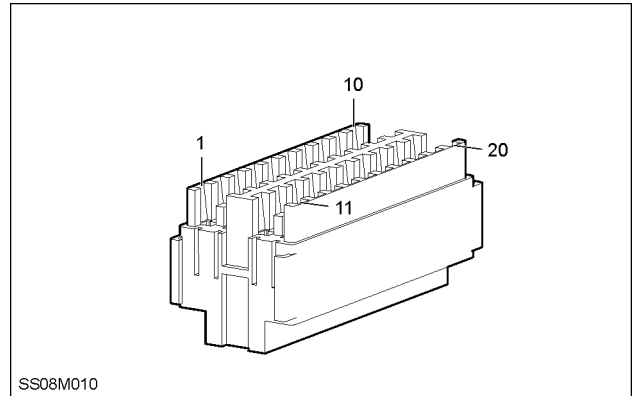

SS08M010 34

X078 Diverter Switch

T6.120 - 175

POS.	COLOR	WIRE NUMBER	CIRCUIT REFERENCE
1	BR	5200	EDC VALVE SUPPLY
2	TN	9000	DIVERTER VALVE

NOTE: For the wiring color code refer to, *Wire harnesses - Identification (55.100)*.

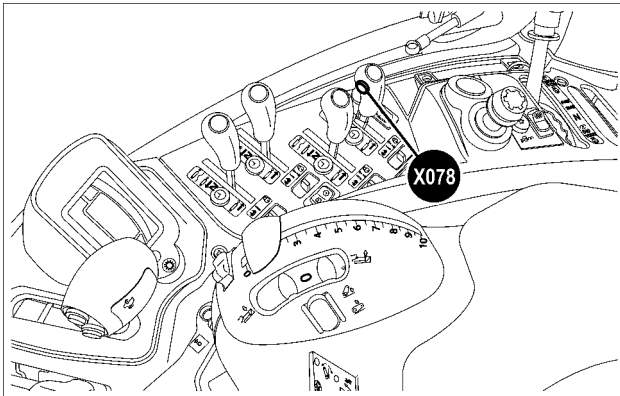

SS12B116 35

RIGHT HAND SIDE BEHIND TRIM

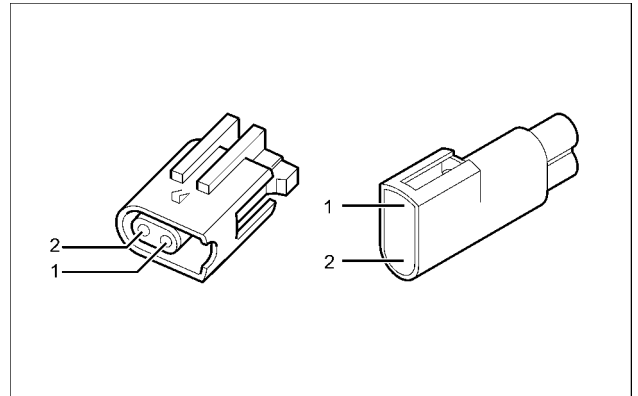

SS12B048 36

HIGH ROOF

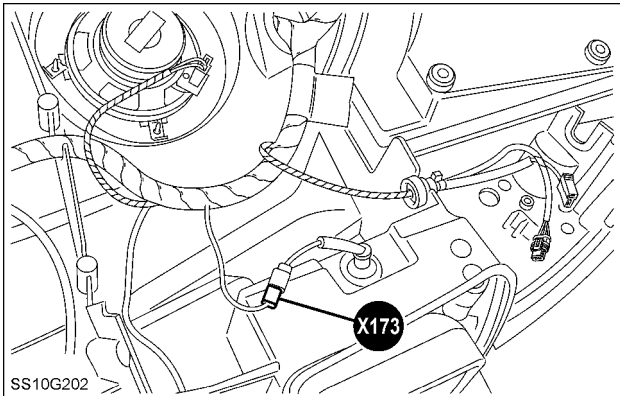

SS10G202 15

REAR RIGHT HAND CAB ROOF

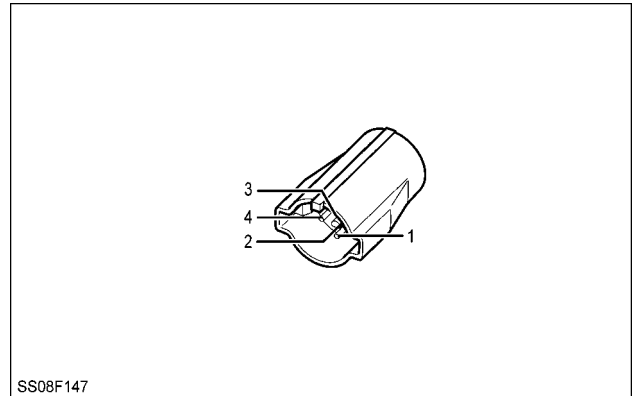

SS08F147 16

LOW ROOF

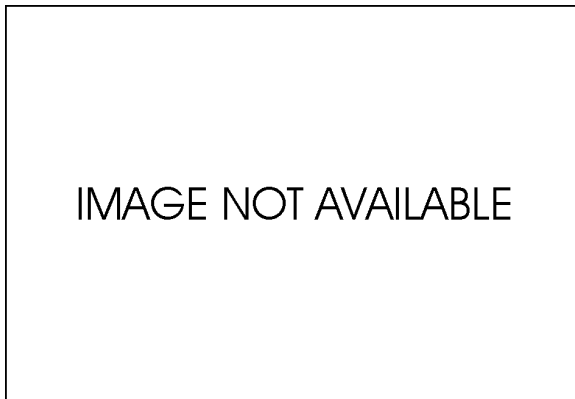

INA 17

REAR RIGHT HAND CAB ROOF

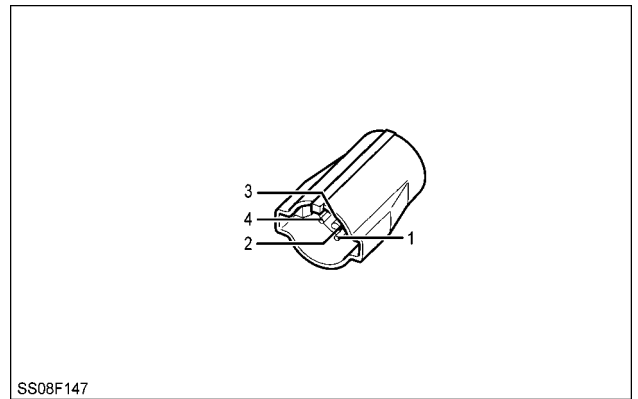

SS08F147 18

X175 Speaker rear right-hand

HIGH ROOF

POS.	COLOR	WIRE NUMBER	CIRCUIT REFERENCE
1	VT	3092	SPEAKER RR-RHS -
2	VT	3091	SPEAKER RR-RHS +

NOTE: For the wiring color code refer to, *Wire harnesses - Identification (55.100)*.

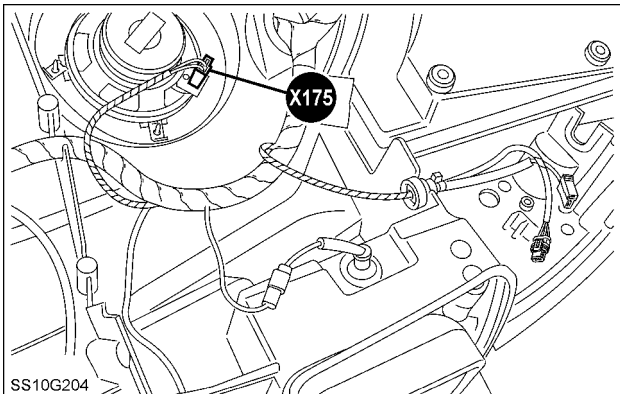

SS10G204 19

REAR RIGHT HAND CAB ROOF

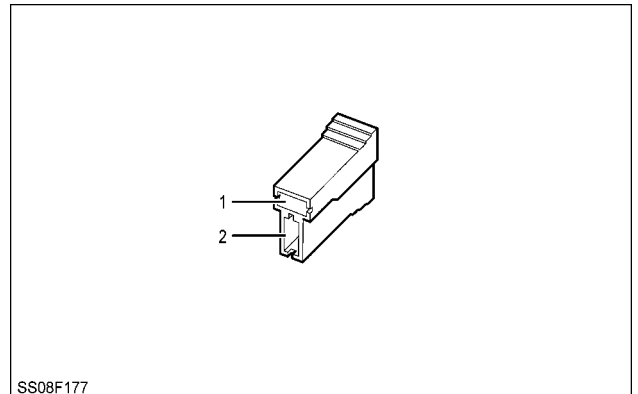

SS08F177 20

24x24 Transmission

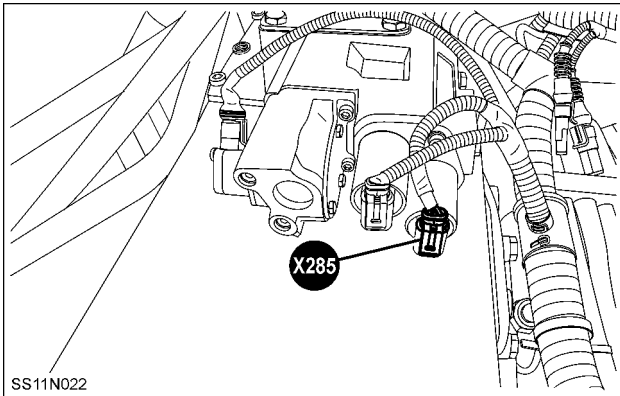

SS11N022 13

LEFT HAND TOP OF TRANSMISSION

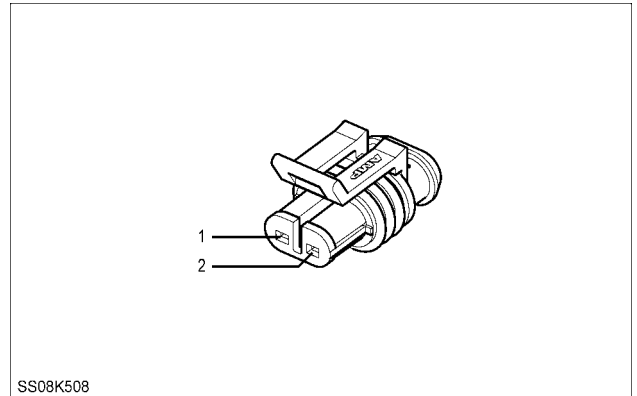

SS08K508 14

X286 Forward Synchro Solenoid

16x16 Transmission

POS.	COLOR	WIRE NUMBER	CIRCUIT REFERENCE
1	LG	8030	TRANS FWD SOLENIOD
2	BK	57	EARTH (ALL)

24x24 Transmission

POS.	COLOR	WIRE NUMBER	CIRCUIT REFERENCE
1	LG	8030	TRANS FWD SOLENIOD
2	VT	8035	TRANS FWD SOL RET

NOTE: For the wiring color code refer to, *Wire harnesses - Identification (55.100)*.

16x16 Transmission

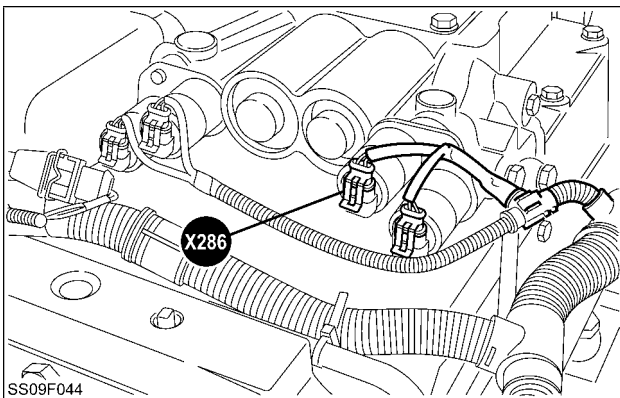

SS09F044 15

LEFT HAND TOP OF TRANSMISSION

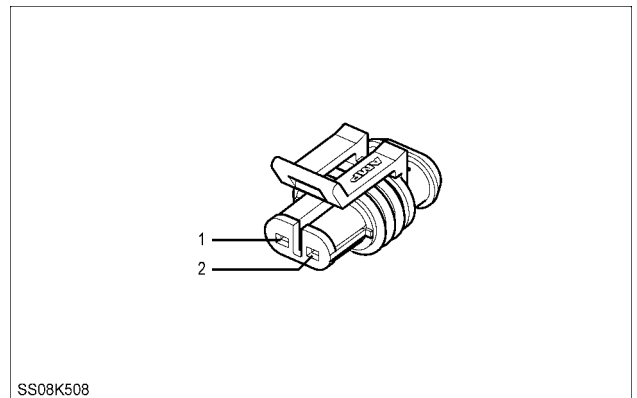

SS08K508 16

T6.140 - 160 AutoCommand

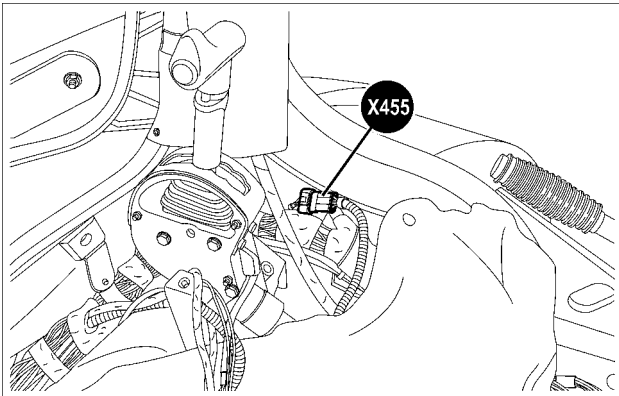

SS12C072 9

BEHIND RIGHT HAND TRIM

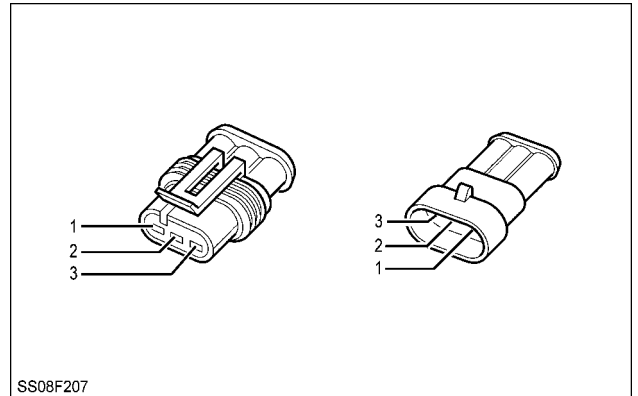

SS08F207

SS08F207 10

T6.120 - 175

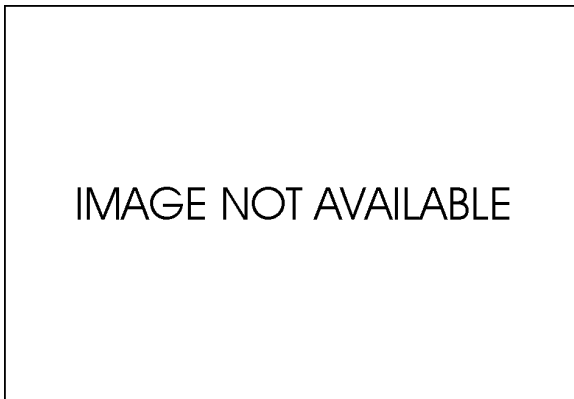

INA 11

BEHIND RIGHT HAND TRIM

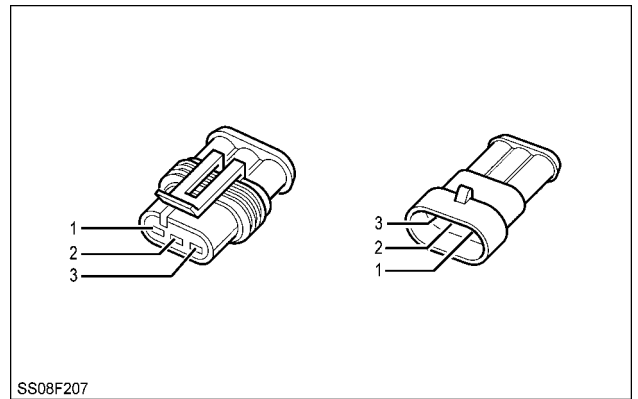

SS08F207

SS08F207 12

X458 Backup alarm buzzer and backup light — Relay

POS.	COLOR	WIRE NUMBER	CIRCUIT REFERENCE
30	OR	3271	LOADER RELAY FEED
85	RD	1160	REVERSE ALARM
86	OR	3271	LOADER RELAY FEED
87	RD	1160	REVERSE ALARM

NOTE: For the wiring color code refer to, *Wire harnesses - Identification (55.100)*.

T6.140 - 160 AutoCommand

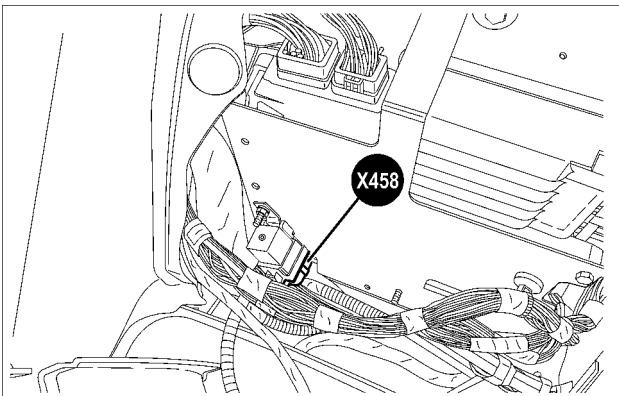

SS12C076 13

BEHIND RIGHT HAND TRIM

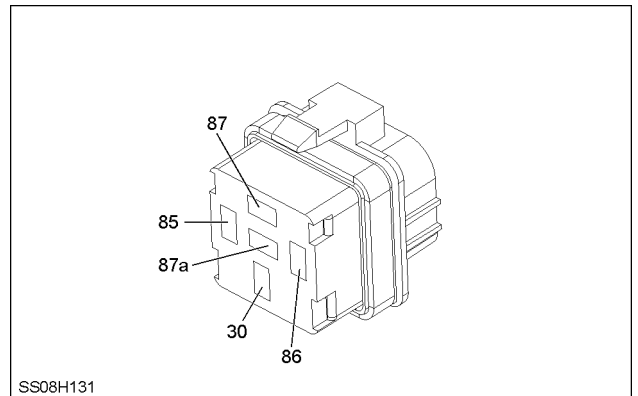

SS08H131

SS08H131 14

X689 Extremity Lamp Right Hand

POS.	COLOR	WIRE NUMBER	CIRCUIT REFERENCE
1	GN	49	RIGHT HAND TURN SIGNAL
2	BK	57	EARTH (ALL)

NOTE: For the wiring color code refer to, **Wire harnesses - Identification (55.100)**.

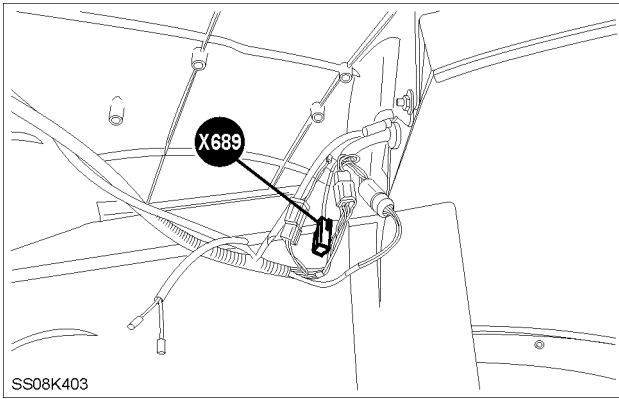

SS08K403 5

RIGHT HAND REAR FENDER

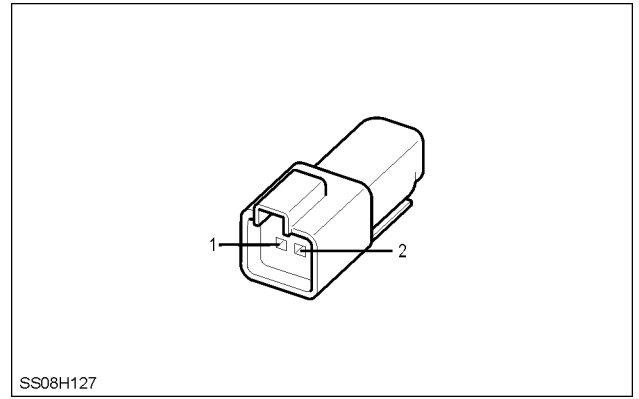

SS08H127 6

T6.140 - 160 AutoCommand

POS.	COLOR	WIRE NUMBER	CIRCUIT REFERENCE
1	WH	-	OUTPUT SIGNAL Z-AXIS
4	BK	-	OUTPUT 1 BUTTON
5	WH	-	OUTPUT SIGNAL Y-AXIS
6	WH	-	OUTPUT SIGNAL X-AXIS
7	BR	-	GROUND
8	RD	-	SUPPLY +5V

NOTE: For the wiring color code refer to, *Wire harnesses - Identification (55.100)*.

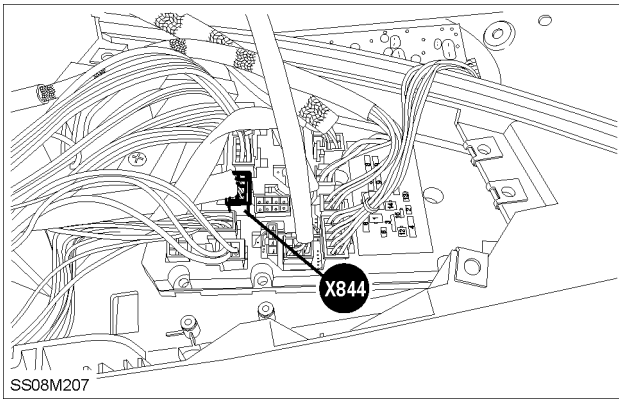

SS08M207 9

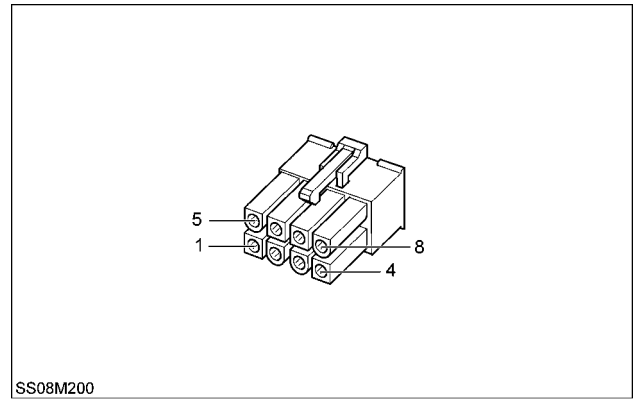

SS08M200 10

In the armrest

X845 Electronic Draft Control (EDC) mouse

T6.140 - 160 AutoCommand

POS.	COLOR	WIRE NUMBER	CIRCUIT REFERENCE
3	OR	-	WORK BUTTON
4	YE	-	RAISE BUTTON
5	BL	-	SIGNAL DRAFT WIPER
6	WH	-	SIGNAL POSITION WIPER
7	BK	-	GROUND
8	RD	-	SUPPLY

NOTE: For the wiring color code refer to, *Wire harnesses - Identification (55.100)*.

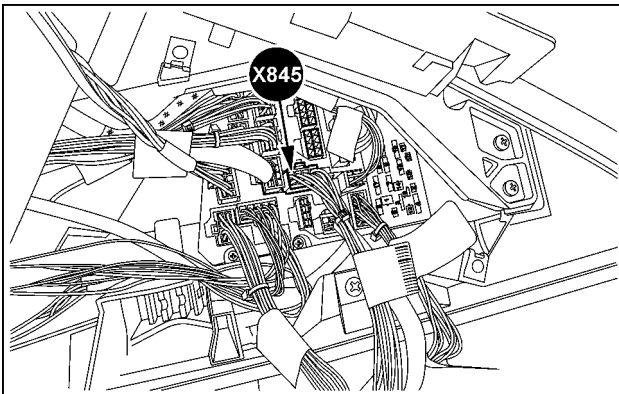

SVIL13TR00923AB 11

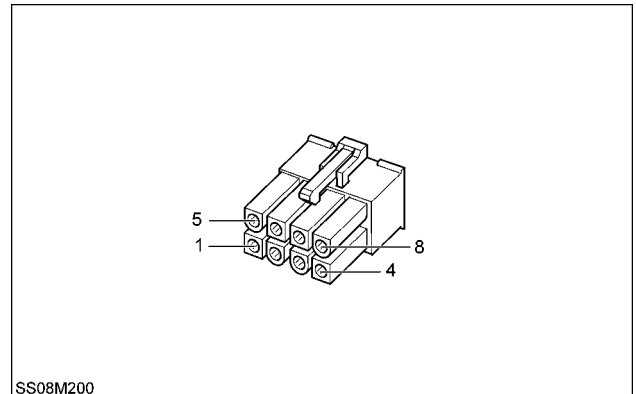

SS08M200 12

In the armrest

Wire harnesses - Electrical schematic sheet 30 HEATING - AIR CONDITION (Manual)	192
Wire harnesses - Electrical schematic sheet 31 MIRRORS (El. Adjustable & Heated)	196
Wire harnesses - Electrical schematic sheet 32 WINDSCREENS HEATING (Front & Rear)	200
T6.140 AutoCommand --- NA, T6.150 AutoCommand --- NA, T6.160 AutoCommand --- NA	
Wire harnesses - Electrical schematic sheet 33 WASHERS & WIPERS (Front & Rear)	202
Wire harnesses - Electrical schematic sheet 34 POWER SOCKETS (Cigar Lighter, Sockets Cab & Rear)	206
Wire harnesses - Electrical schematic sheet 35 FLASH LIGHT & HAZARD WARNING	210
Wire harnesses - Electrical schematic sheet 36 LIGHTING (Side & Console Lamps)	214
Wire harnesses - Electrical schematic sheet 37 FENDER LIGHT (Stop-, Tail-, Flash-, Work Lamps)	220
Wire harnesses - Electrical schematic sheet 38 LIGHTING (Headlamps Hood & Grabrail, Worklamps Hood, Horn)	
.....	224
Wire harnesses - Electrical schematic sheet 39 LIGHTING (Headlamps - Roof)	228
Wire harnesses - Electrical schematic sheet 40 WORKLIGHT (Work- & Beacon Lamps)	232
Wire harnesses - Electrical schematic sheet 41 AUXILIARY WORKLIGHT (Roof)	238
T6.120 --- NA High Roof, T6.140 AutoCommand --- NA, T6.140 --- NA High Roof, T6.150 AutoCommand --- NA, T6.150 --- NA	
High Roof, T6.155 --- NA High Roof, T6.160 AutoCommand --- NA, T6.160 --- NA High Roof, T6.165 --- NA High Roof, T6.175 ---	
NA High Roof	
Wire harnesses - Electrical schematic sheet 42 7-PIN SOCKET (Rear Trailer)	242
Wire harnesses - Electrical schematic sheet 43 INTERIOR LIGHT	246
Wire harnesses - Electrical schematic sheet 44 RADIO	252
Wire harnesses - Electrical schematic sheet 45 COLOR TOUCHSCREEN MONITOR	256
T6.140 AutoCommand --- NA, T6.150 AutoCommand --- NA, T6.160 AutoCommand --- NA	
Wire harnesses - Electrical schematic sheet 46 ELECTRONIC PARK BRAKE	258
Wire harnesses - Electrical schematic sheet 47 TRAILER BRAKES (hydraulic, pneumatic)	262
Wire harnesses - Electrical schematic sheet 48 LOADER READY (Interface)	266
Wire harnesses - Electrical schematic sheet 49 ISO-BUS SYSTEM (Controller, Front & Rear Socket)	270
T6.140 AutoCommand --- NA, T6.150 AutoCommand --- NA, T6.160 AutoCommand --- NA	
Wire harnesses - Electrical schematic sheet 50 DIAGNOSTIC SOCKETS	274
Wire harnesses - Electrical schematic sheet 51 CAN STRUCTURE (CAN BUS1 & CAN BUS NOx)	278
Wire harnesses - Electrical schematic sheet 52 CAN STRUCTURE (EHR CAN)	284
T6.120 --- NA 16x16 Transmission, T6.140 AutoCommand --- NA, T6.140 --- NA 16x16 Transmission, T6.150 AutoCommand ---	
NA, T6.150 --- NA 16x16 Transmission, T6.155 --- NA 16x16 Transmission, T6.160 AutoCommand --- NA, T6.160 --- NA 16x16	
Transmission, T6.165 --- NA 16x16 Transmission, T6.175 --- NA 16x16 Transmission	
Wire harnesses - Electrical schematic sheet 53 CAN STRUCTURE (EHR CAN)	288
T6.120 --- NA 16x16 Transmission, T6.140 AutoCommand --- NA, T6.140 --- NA 16x16 Transmission, T6.150 AutoCommand ---	
NA, T6.150 --- NA 16x16 Transmission, T6.155 --- NA 16x16 Transmission, T6.160 AutoCommand --- NA, T6.160 --- NA 16x16	
Transmission, T6.165 --- NA 16x16 Transmission, T6.175 --- NA 16x16 Transmission	
Wire harnesses - Electrical schematic sheet 54 CAN STRUCTURE (EHR CAN)	292
T6.140 AutoCommand --- NA, T6.150 AutoCommand --- NA, T6.160 AutoCommand --- NA	
Wire harnesses - Electrical schematic sheet 55 CAN STRUCTURE (ISO-BUS CAN)	294
T6.140 AutoCommand --- NA, T6.150 AutoCommand --- NA, T6.160 AutoCommand --- NA	
Wire harnesses - Electrical schematic sheet 56 – FRONT IMPLEMENT SOCKET 30A (DIA)	296
T6.140 AutoCommand --- NA, T6.150 AutoCommand --- NA, T6.160 AutoCommand --- NA	
Fuse and relay box - General specification	7
T6.120 --- NA, T6.140 --- NA, T6.150 --- NA, T6.155 --- NA, T6.160 --- NA, T6.165 --- NA, T6.175 --- NA	
Fuse and relay box - General specification	11
T6.140 AutoCommand --- NA, T6.150 AutoCommand --- NA, T6.160 AutoCommand --- NA	
Fuse and relay box - Static description	699
T6.140 AutoCommand --- NA, T6.150 AutoCommand --- NA, T6.160 AutoCommand --- NA	
Fuse and relay box - Static description	701
T6.120 --- NA, T6.140 --- NA, T6.150 --- NA, T6.155 --- NA, T6.160 --- NA, T6.165 --- NA, T6.175 --- NA	
Wire connectors - Component Diagram 00	299
Wire connectors - Component diagram 01	306
Wire connectors - Component diagram 02	311
Wire connectors - Component diagram 03	324
Wire connectors - Component diagram 04	334
Wire connectors - Component diagram 05	337

CLICK HERE TO **DOWNLOAD** THE COMPLETE MANUAL

- Thank you very much for reading the preview of the manual.
- You can download the complete manual from: www.heydownloads.com by clicking the link below



- Please note: If there is no response to CLICKING the link, please download this PDF first and then click on it.

CLICK HERE TO **DOWNLOAD** THE COMPLETE MANUAL



Electrical systems - 55

Selective Catalytic Reduction (SCR) electrical system - 988

**T6.120 , T6.140 AutoCommand , T6.140 , T6.150 AutoCommand , T6.150 ,
T6.155 , T6.160 AutoCommand , T6.160 , T6.165 , T6.175**

⚠ WARNING

Personal Protective Equipment (PPE) required. When assembling, operating, or servicing the machine, wear protective clothing and PPE necessary for the particular procedure. Some PPE that may be necessary includes protective shoes, eye and/or face protection, hard hat, heavy gloves, filter mask, and hearing protection. Failure to comply could result in death or serious injury.

W0353A

NOTE: Make sure that all openings are sealed. Use new blanking caps.

1. Using a locally fabricated tool, remove the Selective Catalytic Reduction (SCR) heated level sensor.

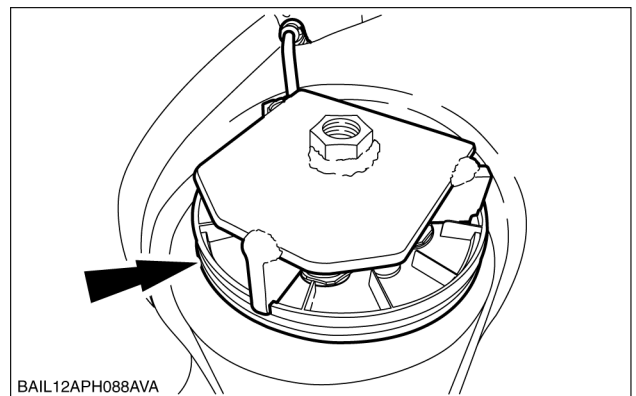

BAIL12APH088AVA

BAIL12APH088AVA 2

Electronic module - Fault code index

T6.120	NA
T6.140	NA
T6.150	NA
T6.155	NA
T6.160	NA
T6.165	NA
T6.175	NA

16x16 Transmission Calibration "U" Codes

Code	Description	Possible Failure
Err	An error has occurred during calibration - the calibration procedure cannot continue – key off	1) Short or open circuit solenoid for clutch 1 is detected 2) Short or open circuit solenoid for clutch 2 is detected 3) Short or open circuit solenoid for clutch 3 is detected 4) Short or open circuit solenoid for clutch 4 is detected
U17	Seat switch not activated	1) Operator not in seat 2) Open circuit for the seat switch input to the transmission module 3) Faulty seat switch 4) Switched 12v supply fuse blown Note: Use the H5 switch diagnostics to detect if the seat switch is connected
U19	Oil temperature below 10 °C	1) Open circuit for the temperature sensor input to module 2) Faulty temperature sensor Note: Use the H9 in the transmission module to see if the temperature sensor input is OK
U20	Handbrake is not set	1) Open circuit for the handbrake feed into the transmission module 2) Faulty handbrake switch 3) Switched 12v supply fuse blown Note: Use the H5 switch diagnostics to detect if the handbrake is connected
U21	ERPM is below 1050, increase throttle	1) Operator has not set the correct engine speed 2) Instrument cluster is not powered 3) Broken CAN Note: Use the H9 in the transmission module to see if the engine speed is being detected
U22	ERPM is above 1350, reduce throttle	1) Operator has not set the correct engine speed
U23	Shuttle lever is in neutral, shift it to forward	1) Operator has not selected forward on the shuttle lever 2) Open circuit between the shuttle lever and the transmission module 3) Switched 12v supply fuse blown Note: Use the H5 switch diagnostics to detect if the switch is connected
U26	Clutch pedal is not up, release clutch pedal	1) Operator has not released the clutch pedal 2) The clutch potentiometer / linkage is sticking or broken Note: Use the H9 in the transmission module to see if the clutch input is OK
U27	C3 calibration value is too low	1) RPM dropped too soon 2) Clutch pressure is not being controlled properly 3) Engine speed adjusted whilst completing calibration
U29	C4 calibration value is too low	1) RPM dropped too soon 2) Clutch pressure is not being controlled properly 3) Engine speed adjusted whilst completing calibration
U31	Wheel speed sensed	1) Handbrake not applied 2) Brakes not working Note: If the brakes are OK move the vehicle forward slightly and repeat calibration
U32	C1 calibration value is too low	1) RPM dropped too soon 2) Clutch pressure is not being controlled properly 3) Engine speed adjusted whilst completing calibration

The lower central display will show "EECL"

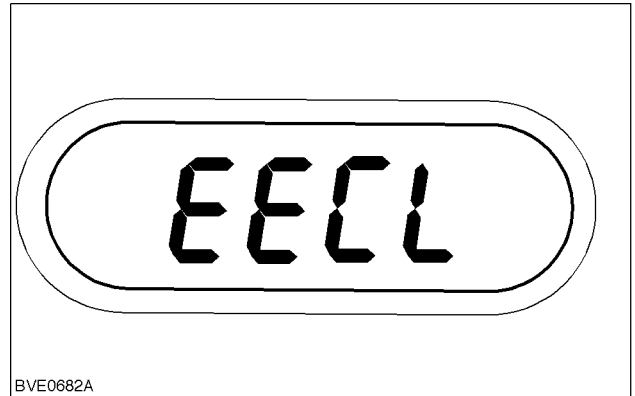

BVE0682A 4

ATTENTION: H8 will clear all calibrations values and stored error codes.

NOTE: If the "m" button is released before the countdown finishes, the procedure will be aborted.

Depress and hold the "m" button to confirm the resetting of the EEPROM.

The lower central display will countdown from 05 to 01, then "EE" will be displayed to indicate the EEPROM has been cleared.

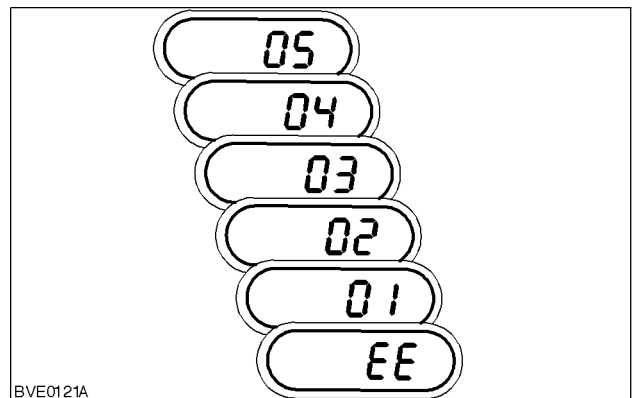

BVE0121A 5

It is not possible to continuing through the "H" menus after an H8 procedure. The only possible action is to turn the ignition key switch off to allow the reset values to be stored.

NOTE: The 'Clear Network Config' procedure is carried out in the same way as 'Clear Settings'

Channel 3 - Not Used

This channel is not used and “_ _ _ _” will be displayed.

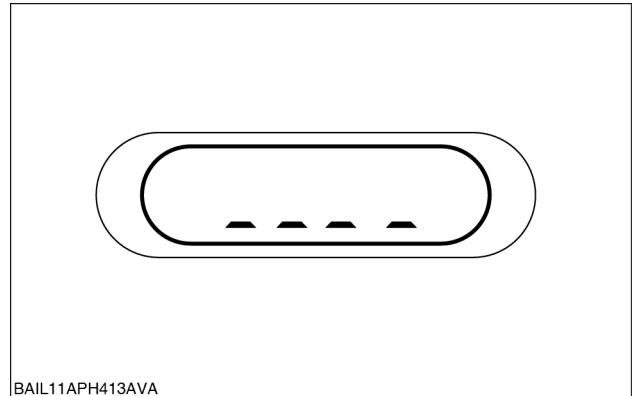

BAIL11APH413AVA

BAIL11APH413AVA 6

Channel 4 - Driver Selectable Shuttle Modes

This channel is used to select memory shuttle.

The “h” and “m” buttons are used to select between “YES” and “no”, indicating whether memory shuttle is selected (“Yes”) or not selected (“No”).

When the desired option is displayed, press and hold down either the “h” or “m” button for 1 second until the instrument cluster bleeps indicating that the selection has been stored.

An alternative shortcut method is also available to allow the shuttle mode to be selected without the use of a service switch. With the keyswitch in the off position, shift the shuttle lever to reverse and press and hold the upshift switch while turning the key switch to the on position (do not start the engine). The lower display will show “YES” or “no” and the shuttle mode can then be selected using the same procedure as above.

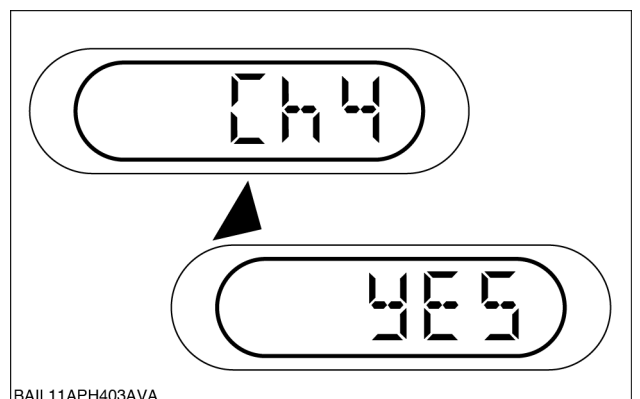

BAIL11APH403AVA

BAIL11APH403AVA 7

When the desired option is displayed depress and hold the “h” or “m” button until the instrument cluster bleeps, indicating the selection has been stored.

Depress the “dimming” button to continue navigating the “HH” menus.

Channels 5 - 40 km/h Maximum Speed Restriction

This channel is used to restrict the transmission to 40 km/h

Electronic module Central Control Unit (CCU) - HC - Clear all stored fault codes

T6.120	NA
T6.140	NA
T6.150	NA
T6.155	NA
T6.160	NA
T6.165	NA
T6.175	NA

This menu can be used to:

- Clear all fault codes stored in all sub-systems in the universal controller
- Clear all fault codes stored in a specific sub-system in the universal controller

HC Menu Screen Select Diagram

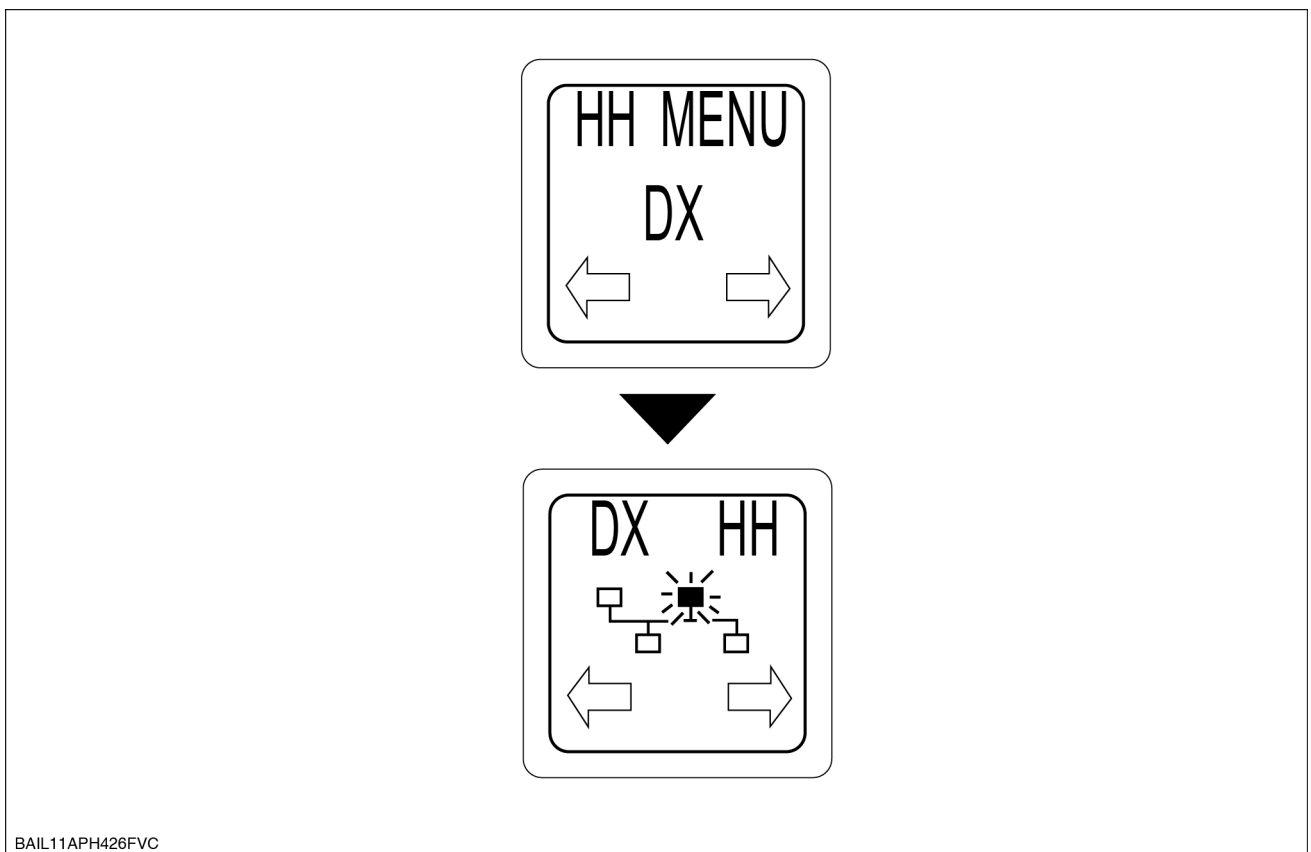

BAIL11APH426FVC 1

Use the "h", "m" and "dimming" buttons on the instrument cluster to navigate the HH menus to H4 on the HU controller.
 Select the H4 menu by depressing the "dimming" button.

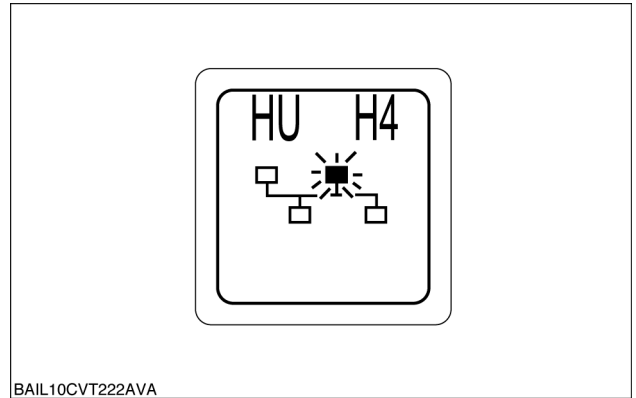

BAIL10CVT222AVA

BAIL10CVT222AVA 3

The lower central display will automatically cycle through the software release, as the example shown and return to allow navigation of the "HH" menus.
 The first set of 4 digits displayed indicates the Software Identifier, this number uniquely defines the application software present in the module. The second and third set of 4 digits displayed define the release version of the application software. In the example shown, these digits indicate that the application software in the module is version 01.03.00.00.

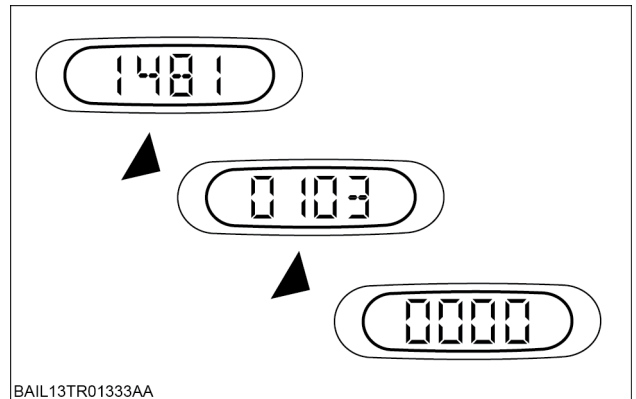

BAIL13TR01333AA

BAIL13TR01333AA 4

NOTE: If enabled, the dyno power boost test will only be active for 45 minutes.

NOTE: The default setting for this option is "OFF".

Depress and hold the "h" or "m" button until the instrument cluster bleeps, indicating the selection has been stored.

Depress the "dimming" button to continue navigating the "HH" menus.

Channel 2 - Not Used

This channel is not used and " _ _ _ " will be displayed.

Channel 3 - Grid Heater Selection

After a delay the current stored option will be displayed.

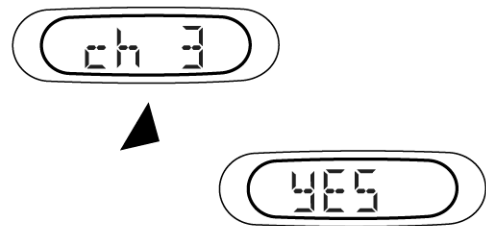

BAIL06CCM505AVA

BAIL06CCM505AVA 15

Use the "h" and "m" buttons to toggle between the available options:

"Yes" - grid heater enabled

"No" - grid heater disabled

NOTE: The default setting for this option is "YES".

Depress and hold the "h" or "m" button until the instrument cluster bleeps, indicating the selection has been stored.

Depress the "dimming" button to continue navigating the "HH" menus.

Channel 4 - Fuel Filter Heater Selection

After a delay the current stored option will be displayed.

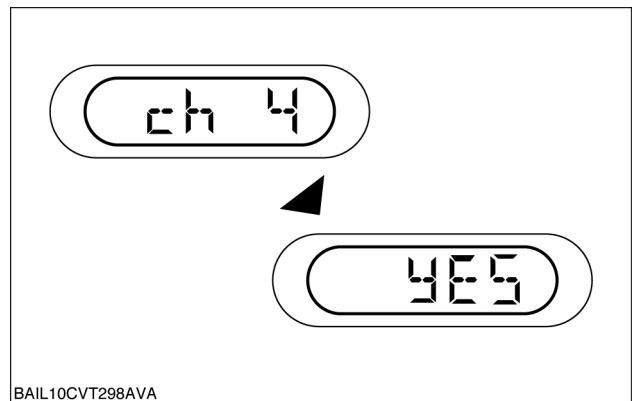

BAIL10CVT298AVA

BAIL10CVT298AVA 16

Use the "h" and "m" buttons to toggle between the available options:

"Yes" - fuel filter heater enabled

"No" - fuel filter disabled

NOTE: The default setting for this option is "no".

Electronic module Universal controller - HJ - Electronic hydraulic remote control valve number programming

T6.140 AutoCommand	NA
T6.150 AutoCommand	NA
T6.160 AutoCommand	NA

NOTE: Each EHR valve has its own built in processor. The processor stores in its memory the valve's number within the EHR stack, i.e. whether it is valve number 1, 2, 3 or 4. If it becomes necessary to replace a valve assembly then it becomes necessary to reprogram the number of each valve within the complete valve assembly. Replacement valve assemblies are supplied with no number assigned. To reprogram the valve number sequence use the following procedure.

NOTE: This procedure details the procedure for renumbering the rear EHR valves, the same procedure applies for renumbering the front valves, using the front EHR sub-system.

ATTENTION: It is essential that the renumbering procedure for a complete set of valves (e.g. all rear valves) must be completed in its entirety before commencing the procedure for the other set of valves.

HJ Menu Screen Select Diagram

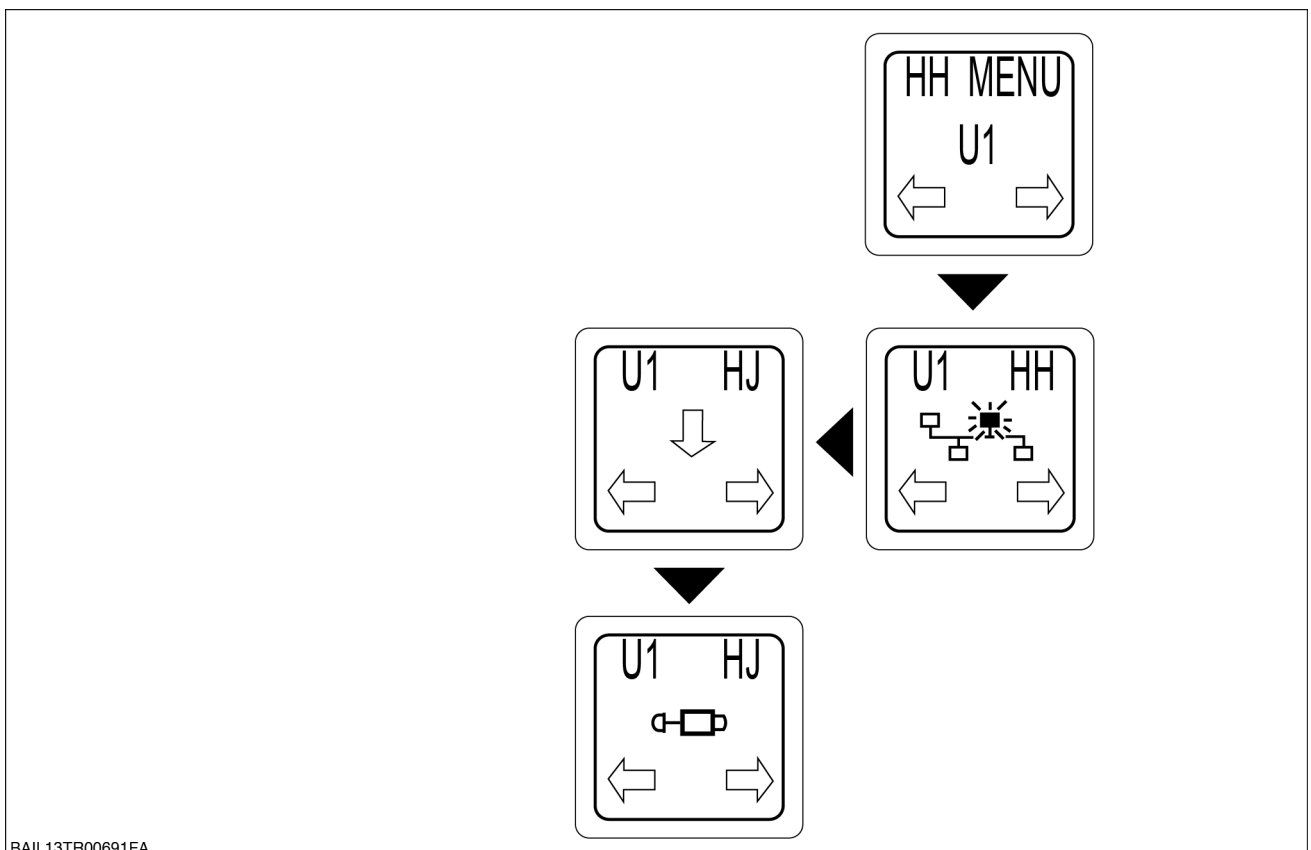

BAIL13TR00691FA 1

Next operation:

Install the right hand rear wheel. See **Rear wheel - Install (44.520)**.

Use the "h", "m" and "dimming" buttons on the instrument cluster to navigate the HH menus to H4 on the XA controller.

Select the H4 menu by depressing the "dimming" button.

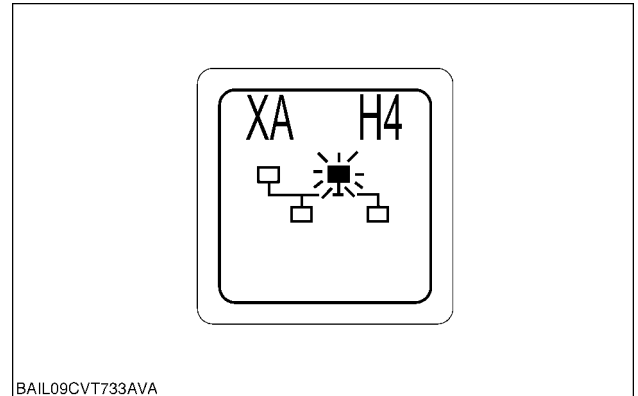

BAIL09CVT733AVA

BAIL09CVT733AVA 3

The display will automatically cycle through the software release, as the example shown and return to allow navigation of the "HH" menus.

The first set of 4 digits displayed indicates the software Identifier, this number uniquely defines the application software present in the module. In the above example 1204 identifies the application software as being software for the XA module.

The second and third set of 4 digits displayed define the release version of the application software. In the example shown above, these digits indicate that the application software in the XA module is currently release 02.00.00.00. The software version displayed by H4 may not match the software version indicated on the label of the module if the new software has been downloaded to the module after manufacture.

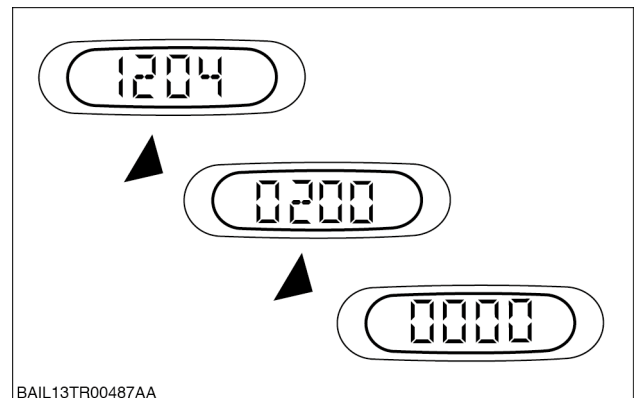

BAIL13TR00487AA

BAIL13TR00487AA 4

Air-conditioning system pressure switch High pressure - Overview

The high pressure switch (1) is located in front of the condenser.

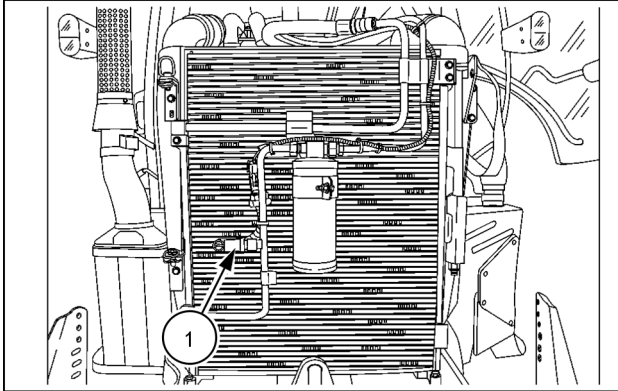

SVIL13TR00580AB 1

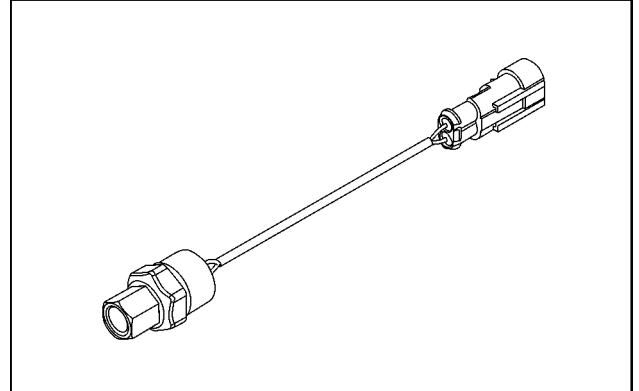

SS13N043 2

Contact (Pin 1-2)	Normally closed contact
On (high pressure switch closed)	16.5 - 17.9 bar (239 - 260 psi)
Off (high pressure switch open)	26.9 - 28.3 bar (390 - 410 psi)
Maximum Current	4 A

The display will automatically cycle through as the example:

0525 Hardware identification

0100 Hardware version

0000 Hardware version

0000 Serial number

0609 Serial number

0054 Serial number

and return to allow navigation of the "HH" menus.

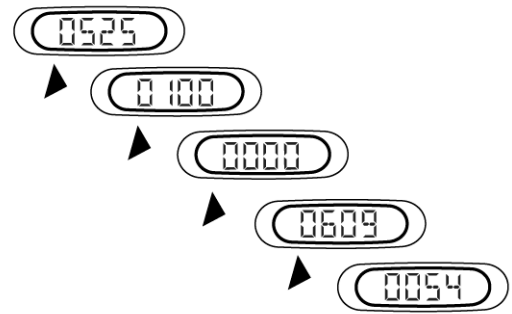

BAIL06CCM687AVA

BAIL06CCM687AVA 3

NOTE: The last three sets of 4 digits displayed represent the 12 digit module serial number. This number should correspond to the serial number shown on the module's label. Note that the serial number shown on the display will include leading zeros that may not be present on the module label. In this example the serial number is 6090054.

Instrument cluster Analog-Digital Instrument Cluster (ADIC) - Dynamic description Senders, Sensors and Switches

T6.120	NA
T6.140	NA
T6.150	NA
T6.155	NA
T6.160	NA
T6.165	NA
T6.175	NA

2095-Clutch 1 Not Calibrated	742
T6.120 --- NA 16x16 Transmission, T6.140 --- NA 16x16 Transmission, T6.150 --- NA 16x16 Transmission, T6.155 --- NA 16x16 Transmission, T6.160 --- NA 16x16 Transmission, T6.165 --- NA 16x16 Transmission, T6.175 --- NA 16x16 Transmission	
2096-Clutch 2 Not Calibrated	743
T6.120 --- NA 16x16 Transmission, T6.140 --- NA 16x16 Transmission, T6.150 --- NA 16x16 Transmission, T6.155 --- NA 16x16 Transmission, T6.160 --- NA 16x16 Transmission, T6.165 --- NA 16x16 Transmission, T6.175 --- NA 16x16 Transmission	
2097-Clutch 5 Not Calibrated	744
T6.120 --- NA 16x16 Transmission, T6.140 --- NA 16x16 Transmission, T6.150 --- NA 16x16 Transmission, T6.155 --- NA 16x16 Transmission, T6.160 --- NA 16x16 Transmission, T6.165 --- NA 16x16 Transmission, T6.175 --- NA 16x16 Transmission	
2098-Clutch 5 Solenoid Short Circuit	745
T6.120 --- NA 16x16 Transmission, T6.140 --- NA 16x16 Transmission, T6.150 --- NA 16x16 Transmission, T6.155 --- NA 16x16 Transmission, T6.160 --- NA 16x16 Transmission, T6.165 --- NA 16x16 Transmission, T6.175 --- NA 16x16 Transmission	
2099-Clutch 5 Solenoid Open Circuit	747
T6.120 --- NA 16x16 Transmission, T6.140 --- NA 16x16 Transmission, T6.150 --- NA 16x16 Transmission, T6.155 --- NA 16x16 Transmission, T6.160 --- NA 16x16 Transmission, T6.165 --- NA 16x16 Transmission, T6.175 --- NA 16x16 Transmission	
2100-Clutch 5 Dump Solenoid Short Circuit	749
T6.120 --- NA 16x16 Transmission, T6.140 --- NA 16x16 Transmission, T6.150 --- NA 16x16 Transmission, T6.155 --- NA 16x16 Transmission, T6.160 --- NA 16x16 Transmission, T6.165 --- NA 16x16 Transmission, T6.175 --- NA 16x16 Transmission	
2101-Clutch 5 Dump Solenoid Open Circuit	751
T6.120 --- NA 16x16 Transmission, T6.140 --- NA 16x16 Transmission, T6.150 --- NA 16x16 Transmission, T6.155 --- NA 16x16 Transmission, T6.160 --- NA 16x16 Transmission, T6.165 --- NA 16x16 Transmission, T6.175 --- NA 16x16 Transmission	
2124-Flywheel Speed Sensor Not Calibrated	753
T6.140 AutoCommand --- NA, T6.150 AutoCommand --- NA, T6.160 AutoCommand --- NA	
2303-Damper calibration - low error	754
T6.140 AutoCommand --- NA, T6.150 AutoCommand --- NA, T6.160 AutoCommand --- NA	
2304-Damper calibration - high error	755
T6.140 AutoCommand --- NA, T6.150 AutoCommand --- NA, T6.160 AutoCommand --- NA	
2331-Clutch slipping fault ("CP" for clutch pedal displayed)	756
T6.140 AutoCommand --- NA, T6.150 AutoCommand --- NA, T6.160 AutoCommand --- NA	
2342-Clutch A solenoid - open circuit or short circuit to ground	757
T6.140 AutoCommand --- NA, T6.150 AutoCommand --- NA, T6.160 AutoCommand --- NA	
2343-Clutch B solenoid - open circuit or short circuit to ground	759
T6.140 AutoCommand --- NA, T6.150 AutoCommand --- NA, T6.160 AutoCommand --- NA	
2352-Clutch A Solenoid - Voltage Too High	761
T6.140 AutoCommand --- NA, T6.150 AutoCommand --- NA, T6.160 AutoCommand --- NA	
2353-Clutch B Solenoid - Voltage Too High	763
T6.140 AutoCommand --- NA, T6.150 AutoCommand --- NA, T6.160 AutoCommand --- NA	
2362-Clutch A Not Calibrated	765
T6.140 AutoCommand --- NA, T6.150 AutoCommand --- NA, T6.160 AutoCommand --- NA	
2363-Clutch B Not Calibrated	766
T6.140 AutoCommand --- NA, T6.150 AutoCommand --- NA, T6.160 AutoCommand --- NA	
2380-Park lock - unable to reach desired position	767
T6.140 AutoCommand --- NA, T6.150 AutoCommand --- NA, T6.160 AutoCommand --- NA	
2381-Park lock - bus off	770
T6.140 AutoCommand --- NA, T6.150 AutoCommand --- NA, T6.160 AutoCommand --- NA	
2382-Park lock - bus integrity error	773
T6.140 AutoCommand --- NA, T6.150 AutoCommand --- NA, T6.160 AutoCommand --- NA	
2386-Shuttle Lever Neutral Switch - Voltage Too High	776
T6.140 AutoCommand --- NA, T6.150 AutoCommand --- NA, T6.160 AutoCommand --- NA	
2387-Shuttle Lever Neutral Switch - Voltage Too Low	778
T6.140 AutoCommand --- NA, T6.150 AutoCommand --- NA, T6.160 AutoCommand --- NA	

1003-Speed Sensor Error

NOTE: When the cause of the error code has been rectified, clear the error code and test the system for normal operation.

Cause:

Possible failure modes:

1. Faulty connector
2. Incorrect tractor performance monitor radar alignment
3. Faulty speed sensor
4. Faulty tractor performance radar
5. Faulty harness
6. Faulty speed pickup gear

Solution:

1. Check for other error codes being displayed.
 - A. If other error codes are displayed, continue to these tests.
 - B. If no other error codes are displayed, continue to step **2**
2. Check the position of the radar.
 - A. If the radar is pointing at the tractor wheel or excessively vibrating, point the radar at the ground and tighten the fixings.
 - B. If the radar mounting and position is okay, continue to step **3**
3. Check the speed sensor.
 - A. If the speed sensor is loose in the rear axle housing or damaged, re-tighten or remove and replace the speed sensor as required.
 - B. If the speed sensor is okay, continue to step **4**
4. Check the speed pickup gear.
 - A. Remove the speed sensor and check for damage to the speed pickup gear inside the rear axle. If any damage is indicated, disassemble the rear axle and replace the speed pickup gear.
 - B. If the speed pickup gear is okay, remove and replace the speed sensor.

1020-Load Sensing Pin 8V Reference Voltage Too High

T6.120	NA
T6.140	NA
T6.150	NA
T6.155	NA
T6.160	NA
T6.165	NA
T6.175	NA

NOTE: When the cause of the error code has been rectified, clear the error code and test the system for normal operation.

Cause:

Possible failure modes:

1. Faulty connector
2. Faulty load sensing pin
3. Faulty harness
4. Faulty controller

Solution:

1. Check the **8 Volts** sensor supply in H9 channel 6. Refer to **Electronic module Central Control Unit (CCU) - H9 - Voltmeter diagnostic (55.640)**.
 - A. If the value displayed is approximately 79, check for an intermittent circuit to the load sensing pin, repair or replace the harness as required. If the error re-occurs and no intermittent circuit is indicated, download the correct level of software. If the fault re-occurs, remove and replace the controller.
 - B. If the value displayed is not approximately 79, continue to step 2
2. Check for a short to **12 Volts**.
 - A. Disconnect the controller connector **X093** and both load sensing pin connectors **X266** and **X256**. Turn the keystore ON. Check between connector:
 - X256** pin 1 (BK/WH) and ground
 - X256** pin 2 (TN) and ground
 - X256** pin 3 (PK) and ground
 - X266** pin 1 (BK/WH) and ground
 - X266** pin 2 (TN) and ground
 - X266** pin 3 (PK) and ground
 If a voltage is indicated, repair or replace the harness as required.
 - B. If the harness is okay, continue to step 3
3. Replace the load sensing pin(s).
 - A. Remove and replace the load sensing pin(s).
 - B. If the error re-occurs, refit the old load sensing pins and download the correct level of software. If the fault re-occurs, remove and replace the controller.

1066-EDC Hydraulic Valve Raise Solenoid Short Circuit

T6.140 AutoCommand	NA
T6.150 AutoCommand	NA
T6.160 AutoCommand	NA

NOTE: When the cause of the error code has been rectified, clear the error code and test the system for normal operation.

Cause:

Possible failure modes:

1. Faulty connector
2. Faulty EDC valve raise solenoid
3. Faulty harness
4. Faulty controller

Solution:

1. Check the EDC valve raise solenoid connector **X268**, the inline harness connector **X022** and the controller connectors **X950** and **X951**.
 - A. Ensure the connectors are connected, not damaged, the pins are in the correct position and that the fit is tight. Repair or replace as required.
 - B. If the connectors are okay, continue to step
2. Check the EDC valve raise solenoid.
 - A. Disconnect the EDC valve raise solenoid connector **X268**. Measure the resistance between the solenoid terminals. If the resistance indicated is not approximately **2 Ohms**, remove and replace the EDC valve raise solenoid.
 - B. If the solenoid is okay, continue to step **3**
3. Check for a short to Ve Voltage.
 - A. Disconnect the controller connectors **X950** and **X951**. Turn the keystore ON. Measure the voltage between connector **X268** pin 1 (PK) and ground. If a voltage is indicated, repair or replace the harness as required.
 - B. If a voltage is not indicated, continue to step **4**
4. Check for a short to Ve Voltage.
 - A. Measure the voltage between connector **X268** pin 2 (PK) and ground. If a voltage is indicated, repair or replace the harness as required.
 - B. If a voltage is not indicated, continue to step **5**
5. Check for a short circuit.
 - A. Check between connector **X268** pin 1 (PK) and **X268** pin 2 (PK). If a short circuit is indicated, repair or replace the harness as required.
 - B. If the harness is okay, download the correct level of software. If the fault re-occurs, remove and replace the controller.

14905-Keypad Missing (JA)

NOTE: When the cause of the error code has been rectified, clear the error code and test the system for normal operation.

Cause:

Possible failure modes:

1. Faulty connector
2. Faulty harness
3. CAN BUS interference
4. Faulty keypad

Solution:

1. Before proceeding clear the error code with the approved diagnostic equipment. Run the tractor under normal conditions and retest.
 - A. If the error code is not indicated, check that the system is operating correctly.
 - B. If the error code is indicated, continue to step **2**
2. Check for other error codes displayed.
 - A. If other error codes are displayed, continue to these tests.
 - B. If no other error codes are displayed, continue to step **3**
3. Check all power supplies and grounds to the keypad.
 - A. If a fault is indicated, repair or replace the harness as required.
 - B. If no faults are indicated, continue to step **4**
4. Check the instrument cluster connector **X009** and the keypad connector **X008**.
 - A. Ensure the connectors are connected, not damaged, the pins are in the correct position and that the fit is tight. Repair or replace as required.
 - B. If the connectors are okay, continue to step **5**
5. Check for an open circuit on the CAN BUS.
 - A. Disconnect connector **X008**. Check between connector:
X030 (CAN High) pin C (YE) and **X008** pin 3 (YE)
X030 (CAN Low) pin D (GN) and **X008** pin 2 (GN)
If an open circuit is indicated, repair or replace the harness as required.
If an open circuit not indicated, continue to step **6**
6. Check for open circuit on the CAN BUS.
 - A. Disconnect connector **X009**. Check between connector:
X009 (CAN High) pin 26 (YE) and **X008** pin 3 (YE)
X009 (CAN Low) pin 25 (GN) and **X008** pin 2 (GN)
If an open circuit is indicated, repair or replace the harness as required.
 - B. If an open circuit not indicated, remove and replace the keypad.

16132-Low Pressure Switch (-) Input Shorted To Power

NOTE: After remedying the cause of the error clear the error code and carry out a functional check of the system.

Cause:

The signal at this input has a short circuit to positive.

Possible failure modes:

1. Connector faulty.
2. Wiring harness is faulty.
3. Controller has internal fault.

Solution:

1. Turn the starter switch to the "OFF" position. Check the plug connections **X755** and **X753**.
 - A. Check that the plug connections are connected, there is no damage, and the pins are in the right position and the connections are secure. Repair or replace the connectors as required.
 - B. If the plug connections are okay, continue to step **2**
2. Check for a short circuit to positive.
 - A. Disconnect the plug connection **X755**. Turn the starter switch to the "ON" position and check the voltage. From **X755** PIN36 (BL) to vehicle ground: **0 V**
If a voltage is indicated, repair or replace the harness as required.
 - B. If no voltage is indicated, continue to step **3**
3. Replacing the controller for the ATC - see **Automatic Temperature Control (ATC) module - Replace (55.050). Wire harnesses - Electrical schematic sheet 29 (55.100.DP-C.20.E.29)**

H5 - X851 - Engine speed drop – Limit potentiometer	H14 - X845 - Electronic Draft Control (EDC) mouse
H6 - X852 - Hand throttle	H15 - X857 / X858 - not used
H7 - X844 - Remote valve joystick (optional joystick 1 or 2)	H16 - X843 - Remote valve float switch
H8 - X853 - Remote control valve 1 and 2 H8 - X854 - Remote valve 1 and 2 – Indicator lights and timer switch	H17 - X862 - Monitor
H9 - X855 - Remote control valve 3 and 4 H9 - X856 - Remote valve 3 and 4 – Indicator lights and timer switch	

- A. Detach the hitch electronic control panel to access the armrest controller. Check the hitch electronic control panel connector H4 (**X850**) is connected to the correct connector on the armrest controller, not damaged, the pins are in the correct position and that the fit is tight. Repair or replace as required.
- B. If the connector is okay, continue to step **3**
3. Check the armrest controller configuration.
 - A. Using the approved diagnostic equipment, check the armrest controller has been configured correctly for the options installed on the machine. If the armrest controller has not been configured correctly, using the approved diagnostic equipment, re-configure the armrest controller.
 - B. If the armrest controller is configured correctly, continue to step **4**
4. Check for other armrest related error codes.
 - A. If several armrest related error codes (18000) are also displayed, download the correct level of software. If the fault recurs, remove and replace the armrest controller. Using the approved diagnostic equipment, configure the armrest controller.
 - B. If other armrest related error codes are not displayed, remove and replace the hitch electronic control panel assembly. If the fault is still present, download the correct level of software. If the fault recurs, remove and replace the armrest controller. Using the approved diagnostic equipment, configure the armrest controller.

H5 - X851 - Engine speed drop – Limit potentiometer	H14 - X845 - Electronic Draft Control (EDC) mouse
H6 - X852 - Hand throttle	H15 - X857 / X858 - not used
H7 - X844 - Remote valve joystick (optional joystick 1 or 2)	H16 - X843 - Remote valve float switch
H8 - X853 - Remote control valve 1 and 2 H8 - X854 - Remote valve 1 and 2 – Indicator lights and timer switch	H17 - X862 - Monitor
H9 - X855 - Remote control valve 3 and 4 H9 - X856 - Remote valve 3 and 4 – Indicator lights and timer switch	

- A. Detach the hitch electronic control panel to access the armrest controller. Check the remote control valve 1 and 2 connector H8 (**X853**) is connected to the correct connector on the armrest controller, not damaged, the pins are in the correct position and that the fit is tight. Repair or replace as required.
- B. If the connector is okay, continue to step **3**
3. Check the armrest controller configuration.
 - A. Using the approved diagnostic equipment, check the armrest controller has been configured correctly for the options installed on the machine. If the armrest controller has not been configured correctly, using the approved diagnostic equipment, re-configure the armrest controller.
 - B. If the armrest controller is configured correctly, continue to step **4**
4. Check for other armrest related error codes.
 - A. If several armrest related error codes (18000) are also displayed, download the correct level of software. If the fault recurs, remove and replace the armrest controller. Using the approved diagnostic equipment, configure the armrest controller.
 - B. If other armrest related error codes are not displayed, remove and replace the remote control valve lever assembly. If the fault is still present, download the correct level of software. If the fault recurs, remove and replace the armrest controller. Using the approved diagnostic equipment, configure the armrest controller.

Wire harnesses - Electrical schematic sheet 25 (55.100.DP-C.20.E.25)

Wire harnesses - Electrical schematic sheet 26 (55.100.DP-C.20.E.26)

19596-CAN receive frame EEC1 (Driver demand, eng speed, eng torque) - SAE J1939 check for CAN receive signal : (engine speed not in range) - P0600 serial communication link

Possible failure modes:

1. Controller communication error

Solution:

1. Check for other error codes being displayed. Are there other codes displayed referring to low DEF/AdBlue® level. Are there other can bus communication error issues.
 - A. If any other error code is being displayed, resolve that code.
 - B. If no other error code is displayed, continue to step 2.
2. Ensure all connectors are secured properly on the SCR controller connector **X914**, the terminator connector **X910** (located below tool box) and engine control module connector **X910**. Check for damage, loose connections or broken can bus wires.
 - A. A connector/wiring issue was located and corrected. Erase fault code and return unit to field operation.
 - B. No connector/wiring issues were located. Continue with step3.
3. Check the can bus terminators. Disconnect terminator connector **X910**. Check the terminators resistance from pin 2 (YE) to pin 3 (GN). The expected reading is **120 Ω**.
 - A. Expected reading is not found. Replace terminator. Erase fault code and return unit to field operation.
 - B. Reading is as expected. Continue with step4.
4. Check the harness end resistance on connector **X910** from pin 2 (YE) to pin 3 (GN). This will be checking the engine control modules internal terminator. The expected reading is **120 Ω**.
 - A. Expected reading not found. There may be a short to ground, or open wire between terminator **X910** and engine control module connector **X911**, or the engine control module terminator is faulty. Troubleshoot the wiring harness make repairs, or replace engine control module.
 - B. Reading is as expected. Erase fault code and test the system for normal operation.

2027-Engine speed no signal

NOTE: When the cause of the error code has been rectified, clear the error code and test the system for normal operation.

Cause:

The measured ERPM average is 0.

Possible failure modes:

1. Faulty connector
2. Faulty speed sensor
3. Mechanical fault

Solution:

1. Check for other error codes being displayed.
 - A. If any other error code is being displayed, continue to these tests.
 - B. If no other error code is displayed, continue to step **2**
2. Check the flywheel speed sensor connector **X289**.
 - A. Ensure the connector is connected, not damaged, the pins are in the correct position and that the fit is tight. Repair or replace as required.
 - B. If the connector is okay, continue to step **3**
3. Check the flywheel speed sensor.
 - A. If installed incorrectly, loose or damaged, refit correctly or replace as required.
 - B. If the sensor is installed correctly, remove and replace the flywheel speed sensor. If fault is still present, possible fault with the speed sensor inductive ring.

Wire harnesses - Electrical schematic sheet 16 (55.100.DP-C.20.E.16)

Wire harnesses - Electrical schematic sheet 06 (55.100.DP-C.20.E.06)

Wire harnesses - Electrical schematic sheet 15 (55.100.DP-C.20.E.15)

Wire harnesses - Electrical schematic sheet 01 (55.100.DP-C.20.E.01)
Wire harnesses - Electrical schematic sheet 03 (55.100.DP-C.20.E.03)
Wire harnesses - Electrical schematic sheet 06 (55.100.DP-C.20.E.06)
Wire harnesses - Electrical schematic sheet 46 (55.100.DP-C.20.E.46)

2551-Stuck dump solenoid or clutch B solenoid

T6.140 AutoCommand	NA
T6.150 AutoCommand	NA
T6.160 AutoCommand	NA

NOTE: When the cause of the error code has been rectified, clear the error code and test the system for normal operation.

Cause:

Mismatch between clutch B pressure command and pressure sensor reading when clutch B is commanded.

Possible failure modes:

1. Faulty dump solenoid
2. Faulty clutch B solenoid
3. Dump solenoid cartridge is stuck
4. Clutch B solenoid cartridge is stuck

Solution:

1. Check for transmission error codes 2035, 2036, or 2506
 - A. If any of these error codes are displayed, go to troubleshooting for these error codes.
 - B. If no error codes are displayed, continue to step 2
2. Check the clutch B solenoid connector **X528** and the dump solenoid connector **X545**.
 - A. Ensure the connectors are connected, not damaged, the pins are in the correct position and that the fit is tight. Repair or replace as required.
 - B. If the connectors are okay, continue to step 3
3. Check the clutch B solenoid.
 - A. Disconnect the clutch B solenoid connector **X528**. Measure the resistance between the solenoid terminals. If the resistance indicated is not between **9.4 - 10.4 Ω** , remove and replace the clutch A solenoid.
 - B. If the solenoid is okay, continue to step 4
4. Check the dump solenoid.
 - A. Disconnect the dump solenoid connector **X545**. Measure the resistance between the solenoid terminals. If the resistance indicated is not between **6.8 - 7.8 Ω** , remove and replace the dump solenoid.
 - B. If the solenoid is okay, continue to step 5
5. One or both the clutch B and dump solenoid cartridge valves are stuck in valve.
 - A. Inspect both cartridge valves.
 - B. If the cartridge valves are not operating correctly, install new cartridge valves.

3159-Invalid Engine Reference Torque

NOTE: When the cause of the error code has been rectified, clear the error code and test the system for normal operation.

Possible failure modes:

1. Engine controller requires the latest level of software

Solution:

1. This error code is no longer valid and is disabled in the latest level of software.
 - A. Download the latest level of software into the engine controller. Clear the error code with the approved diagnostic equipment. Run the machine under normal conditions and retest.

4119-Rear Remote No.2 Over Voltage

T6.120	NA 16x16 Transmission
T6.140	NA 16x16 Transmission
T6.150	NA 16x16 Transmission
T6.155	NA 16x16 Transmission
T6.160	NA 16x16 Transmission
T6.165	NA 16x16 Transmission
T6.175	NA 16x16 Transmission

NOTE: When the cause of the error code has been rectified, clear the error code and test the system for normal operation.

Cause:

Possible failure modes:

1. External power supply connected
2. Faulty charging system
3. Faulty EHR valve

Solution:

1. Check that the tractor battery power supply has not been connected to an external power supply.
 - A. If an external power supply is connected to the tractor, disconnect and test the system for normal operation.
 - B. If an external power supply is not connected to the tractor, continue to step 2
2. Check the battery voltage.
 - A. Start the engine and run at **2000 rev/min**. Measure the battery voltage. If the voltage indicated is greater than approximately **15 Volts**, continue to test for a fault in the charging system.
 - B. If the voltage indicated is between approximately **9 Volts** and **15 Volts**, download the correct level of software into the EHR valve and configure the EHR valve. For further information refer to **Electronic module Auxiliary Control Unit (ACU) - H3 - Configurations and options (55.640)** and **Electronic module Auxiliary Control Unit (ACU) - HJ - Electronic hydraulic remote control valve number programming (55.640)**. If the fault is still present remove, replace, and configure the EHR valve.

4143-Rear Remote No.4 Control Message Not Plausible

T6.120	NA 16x16 Transmission
T6.140	NA 16x16 Transmission
T6.150	NA 16x16 Transmission
T6.155	NA 16x16 Transmission
T6.160	NA 16x16 Transmission
T6.165	NA 16x16 Transmission
T6.175	NA 16x16 Transmission

NOTE: When the cause of the error code has been rectified, clear the error code and test the system for normal operation.

Cause:

Possible failure modes:

1. Faulty connector
2. CAN BUS interference
3. Faulty harness
4. Faulty EHR valve

Solution:

1. Check the EHR valve connector **X308**.
 - A. Ensure the connector is connected, not damaged, the pins are in the correct position and that the fit is tight. Repair or replace as required.
 - B. If the connector is okay, continue to step **2**
2. Check the CAN BUS wires (RD) and (BL).
 - A. If the CAN BUS wires are not twisted together or free from possible interference, repair, re-position or replace the harness as required.
 - B. If the CAN BUS wires are okay, continue to step **3**
3. Check for **12 Volts**.
 - A. Disconnect connector **X308**. Turn the keystore ON. Measure the voltage between connector **X308** pin 1 (GY) and ground. If the voltage indicated is not approximately **+12 Volts**, repair or replace the harness as required.
 - B. If the voltage indicated is approximately **12 Volts**, continue to step **4**
4. Check for an open circuit.
 - A. Turn the keystore OFF. Disconnect the inline harness connector **X020**. Measure the resistance between connector:
 - X308** pin 1 (GY) and **X020** pin 30 (GY)
 - X308** pin 2 (BL) and **X020** pin 32 (BL)
 - X308** pin 3 (RD) and **X020** pin 31 (RD)
 - X308** pin 4 (BK) and ground
 If the resistance indicated is greater than **5 Ohms**, repair or replace the harness as required.
 - B. If the resistance indicated is less than **5 Ohms**, continue to step **5**
5. Check for a short to ground.
 - A. Check between connector:
 - X308** pin 1 (GY) and ground
 - X308** pin 2 (BL) and ground
 - X308** pin 3 (RD) and ground
 If a short to ground is indicated, repair or replace the harness as required.

4182-Rear EHR Control No.4 Short Circuit

T6.120	NA 16x16 Transmission
T6.140	NA 16x16 Transmission
T6.150	NA 16x16 Transmission
T6.155	NA 16x16 Transmission
T6.160	NA 16x16 Transmission
T6.165	NA 16x16 Transmission
T6.175	NA 16x16 Transmission

NOTE: When the cause of the error code has been rectified, clear the error code and test the system for normal operation.

Possible failure modes:

1. Faulty connector
2. Faulty harness
3. Faulty EHR lever potentiometer
4. Faulty controller

Solution:

1. Check the EHR lever 3/4 potentiometer connector **X362**, the inline harness connector **X064** and the controller connectors **X099**, **X100** and **X102**.
 - A. Ensure the connectors are connected, not damaged, the pins are in the correct position and that the fit is tight. Repair or replace as required.
 - B. If the connectors are okay, continue to step **3**
2. Check for **5 Volts**.
 - A. Disconnect connector **X362**. Turn the ignition key switch ON. Measure the voltage between connector **X362** pin 8 (LG) and ground. If the voltage indicated is not approximately **5 Volts**, repair or replace the harness as required.
 - B. If the voltage indicated is approximately **5 Volts**, continue to step **3**
3. Check for an open ground circuit.
 - A. Check between connector **X362** pin 11 (BK) and ground. If an open ground circuit is indicated, repair or replace the harness as required
 - B. If an open ground circuit is not indicated, continue to step **4**
4. Check for a short circuit to ground.
 - A. Turn the ignition key switch OFF. Disconnect connector **X102** Check between connector **X102** pin 7 (BL) and ground. If short to ground is indicated, repair or replace the harness as required
 - B. If a short to ground is not indicated, continue to step **5**
5. Check for a short circuit to a positive voltage.
 - A. Turn the ignition key switch ON. Measure the voltage between connector **X102** pin 7 (BL) and ground. If a voltage is indicated, repair or replace the harness as required
 - B. If a voltage is not indicated, continue to step **6**
6. Check for a short circuit.
 - A. Turn the ignition key switch OFF. Check between connector **X362** pin 10 (LG) and the other pins located in connector **X362**. If a short circuit is indicated, repair or replace the harness as required.
 - B. If the harness is okay, remove and replace the EHR lever potentiometer and perform the EHR lever calibration procedure, refer to **Electronic module Auxiliary Control Unit (ACU) - H1 - Calibration procedures (55.640)**.

4519-Front remote no. 2 - over voltage

T6.140 AutoCommand	NA
T6.150 AutoCommand	NA
T6.160 AutoCommand	NA

NOTE: When the cause of the error code has been rectified, clear the error code and test the system for normal operation.

Possible failure modes:

1. External power supply connected
2. Faulty charging system
3. Faulty Universal Control Module (UCM) software
4. Faulty Electro Hydraulic Remote (EHR) valve

Solution:

1. Check that the tractor battery power supply has not been connected to an external power supply.
 - A. If an external power supply is connected to the tractor, disconnect and test the system for normal operation.
 - B. If an external power supply is not connected to the tractor, continue to step 2
2. Check the battery voltage.
 - A. Start the engine and run at **2000 rev/min**. Measure the battery voltage. If the voltage indicated is greater than approximately **15 Volts**, continue to test for a fault in the charging system.
 - B. If the voltage indicated is between approximately **9 Volts** and **15 Volts**, download the correct level of software into the UCM and configure the EHR valve. For further information refer to **Electronic module Universal controller - H3 - Configurations and options (55.640)** and **Electronic module Universal controller - HJ - Electronic hydraulic remote control valve number programming (55.640)**. If the fault is still present, remove, replace and configure the EHR valve.

5027-Rear PTO Speed Sensor - Open Circuit

T6.120	NA
T6.140	NA
T6.150	NA
T6.155	NA
T6.160	NA
T6.165	NA
T6.175	NA

NOTE: When the cause of the error code has been rectified, clear the error code and test the system for normal operation.

Context:

PTO disabled.

Cause:

Possible failure modes:

1. Faulty connector
2. Faulty sensor
3. Faulty harness
4. Faulty controller

Solution:

1. Check the speed sensor connector **X251**, the inline harness connector **X022** and the controller connector **X091**.
 - A. Ensure the connector is connected, not damaged, the pins are in the correct position and that the fit is tight. Repair or replace as required.
 - B. If the connector is okay, continue to step 2
2. Check for **12 Volts**.
 - A. Disconnect connector **X251**. Turn the keystack ON. Measure the voltage between connector **X251** pin 1 (GN) and ground. If approximately **12 Volts** is not indicated, repair or replace the harness as required.
 - B. If approximately **12 Volts** is indicated, continue to step 3
3. Check for an open ground circuit.
 - A. Check between connector **X251** pin 3 (BK/WH) and ground. If an open circuit is indicated, repair or replace the harness as required.
 - B. If an open circuit is not indicated, continue to step 4
4. Check for an open circuit.
 - A. Turn the keystack OFF. Disconnect connector **X091**. Check between connector **X091** pin 20 (OR) and connector **X251** pin 2 (OR). If an open circuit is indicated, repair or replace the harness as required.
 - B. If the harness is okay, remove and replace the rear PTO speed sensor. If the fault is still present, download the correct level of software. If the fault re-occurs, remove and replace the controller.

Wire harnesses - Electrical schematic sheet 16 (55.100.DP-C.20.E.16)
Wire harnesses - Electrical schematic sheet 23 (55.100.DP-C.20.E.23)
Wire harnesses - Electrical schematic sheet 27 (55.100.DP-C.20.E.27)

- B. If approximately **12 Volts** is indicated, continue to step **7**
- 7. Check for a short circuit.
 - A. Disconnect connector **X955**. Check between connector:
 - X229** pin 2 (PK) and **X229** pin 1 (TN)
 - X229** pin 2 (PK) and **X229** pin 3 (TN)
 - X229** pin 1 (TN) and **X229** pin 3 (TN)If a short to circuit is indicated, repair or replace the harness as required.
 - B. If a short to ground is not indicated, continue to step **8**
- 8. Check for a short to +Ve voltage.
 - A. Turn the keystore ON. Measure the voltage between connector:
 - X229** pin 1 (TN) and ground
 - X229** pin 3 (TN) and groundIf a short to +Ve voltage is indicated, repair or replace the harness as required.
 - B. If the harness is okay, download the correct level of software. If the fault re-occurs, remove and replace the controller.

19094-SCR Dosing valve / pump motor DCU supply voltage

Control Module : DCU

Context:

The Dosing Control Unit (DCU) requires **24.0 V** sourcing to derive the internal voltages it requires for control or sourcing of the devices and components in its control scheme. Source voltage upper and lower limits are established within the DCU.

Cause:

The DCU source voltage is below the lower limit of **12.002 V** for longer than **0.5 s**.

Possible failure modes:

1. DCU source circuit failure.
2. DCU internal failure.

Solution:

1. Check DCU source voltage. Carefully disconnect the DCU connector **X914** from the module. Turn the ignition key switch ON and use a multimeter to measure the voltage from the harness side of the DCU connector pin 3 (GN) and pin 4 (GN) to chassis ground. There should be **24.0 V** on both measurements.
 - A. If there is less than **12.002 V**, continue to step **2**
 - B. If there is greater than **12.002 V**, the DCU may have failed internally. Use EST to clear this fault. Operate the vehicle for longer than **20.0 min**. If the fault does not clear or re-occurs, re-load the appropriate DCU software. If the software re-load does not resolve this fault condition, replace the DCU.

***NOTE:** It is recommended that the **24.0 V** supply be disconnected before disconnecting the DCU connector. Then re-connected to make the voltage measurements requested above.*
2. Check for an open circuit. Turn the ignition key switch OFF. Carefully disconnect the 12 - 24v convertor connector **X918**. Use a multimeter to check for an open circuit between the harness side of the 12 - 24v convertor connector **X918** pin 2 (RD) and the harness side of the DCU connector **X914** pins 3 (GN) and 4 (GN).
 - A. If an open circuit is indicated, repair or replace the harness as necessary.
 - B. If an open circuit is not indicated, continue to step **3**
3. Check the 12 - 24v convertor source voltage. Turn the ignition key switch ON and use a multimeter to measure the voltage from the harness side of the 12 - 24v convertor connector **X918** pins 1 (WH) and 3 (RD) to chassis ground. There should be approximately **12.0 V** on both measurements.
 - A. If the voltage indicated is not approximately **12.0 V**, repair or replace the harness as necessary.
 - B. If the voltage indicated is approximately **12.0 V**, continue to step **4**
4. Check the 12 - 24v convertor ground. Use a multimeter to check for an open circuit between the harness side of the 12 - 24v convertor connector **X918** pin 4 (BK) and chassis ground.
 - A. If an open circuit is indicated, repair or replace the harness as necessary.
 - B. If no fault with the wiring harness is indicated, replace the 12 - 24v convertor and check the system for correct operation.

19649-UREA tank level error (CAN message or electrical with real sensor) – tank level sensor - open circuit

Control Module : DCU

Context:

The Dosing Control Unit (DCU) **A-082** has sensed the level of DEF/AdBlue® has dropped below a predetermined level. If the signal is lower than **0.2 V** for **0.5 s** this fault will occur.

Cause:

There is an short circuit in the DEF/AdBlue® heated tank temperature/level sensor circuit.

Possible failure modes:

1. A faulty DEF/AdBlue® heated tank temperature/level sensor.
2. A faulty wiring harness or connection.
3. A faulty DCU.

Solution:

1. Verify this fault code is still present, and in an active state.
 - A. If the fault is still present and active, continue with step **2**.
 - B. If the fault is no longer present or is in an inactive state, continue with step **5**.
2. Disconnect the wiring harness from the DEF/AdBlue® heated tank temperature/level sensor at connector **X907**. Measure the resistance on the sensor from pin 3 to pin 2. There should be approximately

Temperature	Resistance (Approximately)
-55 °C (-67.0 °F)	59975 Ω
-50 °C (-58.0 °F)	43010 Ω
-45 °C (-49.0 °F)	31243 Ω
-40 °C (-40.0 °F)	22973 Ω
-35 °C (-31.0 °F)	17088 Ω
-30 °C (-22.0 °F)	12850 Ω
-25 °C (-13.0 °F)	9764 Ω
-20 °C (-4.0 °F)	7492 Ω
-15 °C (5.0 °F)	5803 Ω
-10 °C (14.0 °F)	4534 Ω
-5 °C (23.0 °F)	3573 Ω
0 °C (32.0 °F)	2838 Ω
5 °C (41.0 °F)	2272 Ω
10 °C (50.0 °F)	1832 Ω
15 °C (59.0 °F)	1487 Ω
20 °C (68.0 °F)	1215 Ω
25 °C (77.0 °F)	1000 Ω
30 °C (86.0 °F)	827 Ω
35 °C (95.0 °F)	688 Ω
40 °C (104.0 °F)	576 Ω
45 °C (113.0 °F)	484 Ω
50 °C (122.0 °F)	409 Ω
55 °C (131.0 °F)	347 Ω
60 °C (140.0 °F)	295 Ω
65 °C (149.0 °F)	252 Ω
70 °C (158.0 °F)	216 Ω

3. Continuity	X828 , pin 3 (OR/BL)	X912 , pin 33 (OR/BL)	Approx. 0 - 0.10 ohms
4. Continuity	X828 , pin 4 (BL/BK)	X912 , pin 34 (BL/BK)	Approx. 0 - 0.10 ohms
5. Shorts	X912 , pin 36 (WH/RD)	X912 , pins 25 (YE/BK), 34 (BL/BK) and 33 (OR/BL)	Open Circuit
6. Shorts	X912 , pin 25 (YE/BK)	X912 , pins 34 (BL/BK) and 33 (OR/BL)	Open Circuit
7. Shorts	X912 , pin 34 (BL/BK)	X912 , pin 33 (OR/BL)	Open Circuit

A. If continuity/shorts test is successful, go to step 5.

B. If continuity/shorts test is unsuccessful, find and repair the damaged section(s) of the wiring harness.

4. Check Boost pressure sensor for proper operation. Place the ignition switch OFF. Remove the Boost Pressure sensor connector **X828** and remove the sensor from the engine intake manifold. Allow the sensor to cool to ambient temperature for several minutes, and then test sensor resistance across pins 2 and 3, using the table of resistance vs. temperature below. Approximate the ambient air temperature when performing the test. Boost Pressure sensor failures are typically at the extreme ends of the table or off the table entirely. Use the test lead labeled "Air Press/Temp Sensor" from the Tier II (NEF) Diagnostic Repair Kit **380040185** to access the contacts on the Boost Pressure sensor (pins 2 and 3).

Temperature	Resistance Nominal Value	Resistance Min/Max. Range
-40 °C (-40 °F)	48153 ohms	45301 - 51006 ohms
-35 °C (-31 °F)	35763 ohms	33703 - 37823 ohms
-30 °C (-22 °F)	26854 ohms	25350 - 28359 ohms
-25 °C (-13 °F)	20376 ohms	19265 - 21487 ohms
-20 °C (-4 °F)	15614 ohms	14785 - 16443 ohms
-15 °C (5 °F)	12078 ohms	11453 - 12702 ohms
-10 °C (14 °F)	9426 ohms	8951 - 9901 ohms
-5 °C (23 °F)	7419 ohms	7055 - 7783 ohms
0 °C (32 °F)	5887 ohms	5605 - 6168 ohms
5 °C (41 °F)	4707 ohms	4487 - 4926 ohms
10 °C (50 °F)	3791 ohms	3618 - 3964 ohms
15 °C (59 °F)	3075 ohms	2939 - 3211 ohms
20 °C (68 °F)	2511 ohms	2402 - 2619 ohms
25 °C (77 °F)	2063 ohms	1976 - 2150 ohms
30 °C (86 °F)	1715 ohms	1645 - 1786 ohms
35 °C (95 °F)	1432 ohms	1374 - 1490 ohms
40 °C (104 °F)	1199 ohms	1152 - 1247 ohms
45 °C (113 °F)	1009 ohms	970 - 1047 ohms
50 °C (122 °F)	851 ohms	819 - 883 ohms
55 °C (131 °F)	721 ohms	694 - 747 ohms
60 °C (140 °F)	612 ohms	590 - 634 ohms
65 °C (149 °F)	522 ohms	503 - 540 ohms
70 °C (158 °F)	446 ohms	431 - 462 ohms
75 °C (167 °F)	383 ohms	370 - 396 ohms
80 °C (176 °F)	329 ohms	319 - 340 ohms
85 °C (185 °F)	284 ohms	275 - 293 ohms
90 °C (194 °F)	246 ohms	238 - 254 ohms
95 °C (203 °F)	214 ohms	207 - 220 ohms
100 °C (212 °F)	186 ohms	180 - 192 ohms
105 °C (221 °F)	162 ohms	157 - 167 ohms
110 °C (230 °F)	142 ohms	138 - 147 ohms
115 °C (239 °F)	125 ohms	121 - 129 ohms
120 °C (248 °F)	110 ohms	106 - 113 ohms
125 °C (257 °F)	97 ohms	93 - 100 ohms
130 °C (266 °F)	85 ohms	83 - 88 ohms

A. If the resistance measurement does not approximately match the table, replace the sensor.

- B. If resistance test was successful, reconnect connector **X827**. Proceed to step **3**.
3. Operation: Injector Resistance Test ECU harness side of connector **X913** to Cylinder #5 injector.
Vehicle Status: Key Off Engine Off.

Remove ECU connector **X913** and perform an injector resistance test. Use the spade style test leads from the Tier II (NEF) Diagnostic Repair Kit # **380040185** when probing the ECU harness side of connector **X913**. Make sure that the multi-meter's test lead resistance is taken into account when resistance measurements are taken. Record the multi-meter's test lead resistance by touching the leads together on the lowest Ohms scale and mentally recording the resistance value. Subtract this value from the actual resistance measurement taken. See test table below.

Test Type	From	To	Expected Results
1. Resistance	ECU harness connector X913 , pin 1 (OR/BL)	ECU harness connector X913 , pin 16 (GN/YE)	Approx. 0.4 - 0.5 ohms

- A. If resistance test was not successful, repair wiring harness between ECU harness connector **X913** and connector **X827**.
- B. If resistance test was successful, proceed to step **5**.
4. Operation: Standalone Injector Resistance Test.
Vehicle Status: Key Off Engine Off.

Remove valve cover from the top of the head to allow access to the internal injector wiring harness. Remove the Cylinder #5 injector connector (two flying leads with ring terminals). Perform a resistance test on the terminals located on top of the solenoid portion of the injector. Make sure that the multi-meter's test lead resistance is taken into consideration when resistance measurements are taken. Record the multi-meter's test lead resistance by touching the leads together on the lowest Ohms scale and mentally recording the resistance value. Subtract this value from the actual resistance measurement taken. See test table below.

Test Type	From	To	Expected Results
1. Resistance	Cylinder #5 injector, terminal #1	Cylinder #5 injector, terminal #2	Approx. 0.4 - 0.5 ohms

- A. If resistance test was successful, repair the internal harness between the Cylinder #5 injector and the connector **X827**.
- B. If resistance test was not successful, replace the Cylinder #5 injector.
5. Operation: Check for ECU Voltages and Ground Continuity.
Vehicle Status (when removing ECU connector **X911**) Key Off Engine Off.
Vehicle Status (when performing test) Key On Engine Off.
Vehicle Status (when replacing ECU connector **X911**) Key Off Engine Off.

Remove connector **X911** from the ECU and check for voltage and continuity at the appropriate pins defined in the test table below. Use the **0.43 mm (0.017 in)** diameter test probes from the Tier II (NEF) Diagnostic Repair Kit # **380040185** when connecting the DMM to the ECU connector **X911**. Make sure the DMM's test lead resistance is taken into account when making any continuity measurements.

Important Note: Check and verify that the Vehicle Status is correct for each operation. Potential ECU damage could result when removing and replacing main ECU connectors if this is not followed.

Test Type	From	To	Expected Results
1. Voltage	ECU connector X911 , pins 2, 3, 8, 9 (GN) and 40 (WH)	Ground (engine block)	Approx. 12.0 volts (DC)
2. Continuity	ECU connector X911 , pins 5, 6, 10 and 11 (BK)	Ground (engine block)	Approx. 0.0 - 0.1 ohms

- A. If the voltages and ground paths are correct, proceed to step **6**.
- B. If the voltages and ground paths are not correct, refer to product schematic and determine root cause of power and/or continuity problem(s).
6. Operation: Re-initialize the ECU.

5. Perform both (2) electrical tests defined below:

1) AC output voltage test for Crankshaft speed sensor

NOTE: When performing this electrical test, use the test lead labeled "Coolant/Fuel Temp Sensor" from the Tier II (NEF) Diagnostic Repair Kit **380040185**.

Check Crankshaft speed sensor Output Voltage and Harness Wiring. Place the ignition switch OFF when setting up test. Remove Crankshaft speed sensor connector **X834** and connect the Coolant/Fuel Temp Sensor test lead in-line with the sensor and the engine wiring harness. Make sure that the signal polarity is not swapped during the connection process. Start the engine and measure the (AC) voltage using a multi-meter across the breakout alligator clips from the Coolant/Fuel Temp Sensor test lead. Use the table below to determine test parameters and the measurement results.

Test Type	From	To	Expected Results
1. Voltage (AC) - In-line connection at low RPM (1000 - 1100 RPM)	Crankshaft speed sensor connector X834 , pin 1 (WH)	Crankshaft speed sensor connector X834 , pin 2 (RD)	Approx. 10 - 12 volts (AC)
2. Voltage (AC) - In-line connection at high RPM (2000 - 2200 RPM)	Crankshaft speed sensor connector X834 , pin 1 (WH)	Crankshaft speed sensor connector X834 , pin 2 (RD)	Approx. 14 - 17 volts (AC)

2) Harness wiring continuity/shorts electrical test (Crankshaft speed sensor).

Place the ignition switch OFF. Remove and perform continuity tests between Crankshaft speed sensor connector **X834** and ECU engine harness connector **X912** on engine wiring harness. Flex harness during test to check for any intermittent operation. Use the test lead labeled "Coolant/Fuel Temp Sensor" from the Tier II (NEF) Diagnostic Repair Kit **380040185** to be able to access the pins on the Crankshaft speed sensor connector **X834**. Also, use the **0.4 mm (0.017 in)** diameter test probes from the repair kit when connecting the multi-meter to connector **X912**. Make sure the multi meter's test lead resistance is taken into account when taking continuity measurements. See test table below.

Important Note: Check and verify that the Vehicle Status is correct. Potential ECU damage could result when removing main ECU connectors if this is not followed.

Test Type	From	To	Expected Results
1. Continuity	Crankshaft speed sensor connector X834 , pin 1 (WH)	ECU engine harness connector X912 , pin 19 (WH)	Approx. 0 - 0.1 ohms
2. Continuity	Crankshaft speed sensor connector X834 , pin 2 (RD)	ECU engine harness connector X912 , pin 23 (RD)	Approx. 0 - 0.1 ohms
3. Shorts	ECU engine harness connector X912 , pin 23 (RD)	ECU engine harness connector X912 , pin 19 (WH)	Open Circuit

A. If both electrical tests are successful, proceed to step **7**.

B. If harness wiring continuity/shorts test was not successful, find and repair the damaged section(s) of the wiring harness.

C. If the voltage test was not successful and the continuity/shorts test was successful, proceed to step **6**.

6. Check proper mechanical alignment and tooth spacing of the Crankshaft speed sensor. Place the ignition switch OFF. The spacing between the trigger teeth and the sensor is critical for proper voltage output. Make sure that the sensor is seated properly (flush with mounting flange). After the sensor alignment is complete, check to see if this fault code has cleared.

A. If this fault code is still present and has not cleared, Replace Crankshaft speed sensor, being careful to ensure the sensor's mechanical alignment and tooth spacing is correct and the sensor is seated properly.

B. If this fault code is still present and has not cleared, proceed to step **13**.

use the **0.4 mm (0.017 in)** diameter test probes from the repair kit when connecting the digital multi-meter (DMM) to the connector **X912**. Make sure the DMM's test lead resistance is taken into account when making continuity measurements. See test table below.

Important Note:

Check and verify that the Vehicle Status is correct. Potential ECU damage could result when removing main ECU connectors if this is not followed.

Test Type	From	To	Expected Results
1. Continuity	X831 , pin 1 (OR/GN)	X912 , pin 15 (OR/GN)	Approx. 0 - 0.10 ohms
2. Continuity	X831 , pin 2 (WH/YE)	X912 , pin 26 (WH/YE)	Approx. 0 - 0.10 ohms
3. Short Circuit	X912 , pin 15 (OR/GN)	X912 , pin 32 (BR/BK)	Open Circuit
4. Short Circuit	X912 , pin 15 (OR/GN)	X912 , pin 33 (OR/BL)	Open Circuit
5. Short Circuit	X912 , pin 15 (OR/GN)	X912 , pin 26 (WH/YE)	Open Circuit

A. If continuity/shorts test is successful, go to step **5**.

B. If continuity/shorts test is unsuccessful, find and repair the damaged section(s) of the wiring harness.

5. Operation: Coolant temp sensor Test
Vehicle Status: Key Off Engine Off.

Remove **X831** connector and test resistance of Coolant temp sensor using the table of resistance vs. temp. below. Approximate the temperature when performing test. Coolant temp sensor failures are typically at the extreme ends of the table or off the table entirely. Use the test lead labeled "Coolant/Fuel Temp Sensor" from the Tier II (NEF) Diagnostic Repair Kit **380040185** to access the pins on the sensor.

Coolant Temperature	Resistance Value
-20 °C (-4 °F)	10.5 kOhm
0 °C (32 °F)	7500 ohms
20 °C (68 °F)	4200 ohms
40 °C (104 °F)	980 ohms
60 °C (140 °F)	780 ohms
80 °C (176 °F)	500 ohms
100 °C (212 °F)	280 ohms
120 °C (248 °F)	97 ohms

A. If the resistance measurement does not approximately match the table, replace the sensor.

B. If the resistance measurement does approximately match the table, proceed to step **6**.

6. Operation: Check for ECU Voltages and Ground Continuity.
Vehicle Status (when removing connector **X911**): Key Off Engine Off.
Vehicle Status (when performing test): Key On Engine Off.
Vehicle Status (when replacing connector **X911**): Key Off Engine Off.

Use product schematic for a reference, remove connector **X911** from the ECU and check for **12 volts** and continuity at the appropriate pins defined in the test table below. Use the **0.4 mm (0.017 in)** diameter test probes from the Tier II (NEF) Diagnostic Repair Kit **380040185** when connecting the DMM to the connector **X911**. Make sure the DMM's test lead resistance is taken into account when making any continuity measurements.

Important Note:

Check and verify that the Vehicle Status is correct for each operation. Potential ECU damage could result when removing and replacing main ECU connectors if this is not followed.

Test Type	From	To	Expected Results
1. Voltage	X911 , pins 2, 3, 8, 9 (GN) and 40 (WH)	Ground (engine block)	Approx. 12 volts
2. Continuity	X911 , pins 5, 6, 10 and 11 (BK)	Ground (engine block)	Approx. 0 - 0.10 ohms

Use a multimeter to measure the resistance of the CAN bus circuit from the diagnostic connector **X030** between pin C to pin D.

There should be approximately **54 - 66 Ω**.

A. If the CAN bus readings are incorrect, continue with Step 5.

B. If the CAN bus readings are correct, continue with Step 7.

5. Measure the resistance of the CAN bus circuit with one terminating resistor removed.

Place the key switch OFF.

Disconnect the wiring harness from the ECU, connector **X911**.

Use a multimeter to measure the resistance from the ECU wiring harness connector **X911** between pin 35 (YE) and pin 34 (GN).

There should be approximately **108 - 132 Ω**.

A. If the CAN bus readings are incorrect, check the CAN bus wiring and terminating resistor between the ECU to the vehicle controllers.

B. If the CAN bus readings are correct, continue with Step 6.

NOTE: *The ECU has an internal terminating resistor.*

6. Check the internal resistor located in the ECU.

Use a multimeter to measure the resistance from the ECU connector **X911** between pin 35 and pin 34.

There should be approximately **108 - 132 Ω**.

A. If the readings are incorrect, the resistor has failed. Replace the ECU.

B. If the readings are correct, continue with Step 7.

NOTE: *If the resistance test is correct at the diagnostic connector port, and the CAN circuit is still "Off line". There may be an OPEN circuit at one of the control modules (nodes).*

7. Check the power and ground supplies to the controllers (nodes).

Verify that the connectors are fully installed.

Flex the harnesses involved to reveal intermittent breaks or shorts in the wiring concerned.

A. If damage is found or other than normal readings are indicated, repair the damage discovered during the inspection or locate and repair the other than normal conditions and verify that the fault code has been resolved.

B. If no damage or other than normal display readings are indicated, clear the fault code and continue operation.

3586-Plausibility check of catalyst system - temperature after catalyst not plausible

Control Module : ECU

Context:

The temperature sensors downstream and upstream of the SCR catalyst, together with the ambient temperature signal are checked for static plausibility against each other. This is done once for each driving cycle and only during cold start when all temperatures should still be the same. Depending on the availability/defectiveness of the temperature sensors, the plausibility check can vary.

Cause:

Downstream temperatures are not plausible. There is a difference of **20 °C (68.0 °F)**, between the sensors.

Possible failure modes:

1. Faulty downstream temperature sensor
2. Faulty electrical wiring or connectors

Solution:

1. Verify this error code is still present and in an active state.
 - A. If the error is still present and active, continue with step **2**.
 - B. If the error is no longer present or is in an inactive state, continue with step **5**.
2. Ensure engine has been allowed to cool down for over **600 min**. Disconnect the wiring harness from the ambient temperature sensor, connector **X908**. Use a multi-meter to measure the resistance from ambient temperature sensor connector pin 3 to pin 4. There should be approximately

Temperature	Resistance (Approximately)
-40 °C (-40.0 °F)	42172 Ω
-30 °C (-22.0 °F)	24760 Ω
-20 °C (-4.0 °F)	14995 Ω
-10 °C (14.0 °F)	9348 Ω
0 °C (32.0 °F)	5988 Ω
10 °C (50.0 °F)	3933 Ω
20 °C (68.0 °F)	2644 Ω
30 °C (86.0 °F)	1817 Ω
40 °C (104.0 °F)	1274 Ω
50 °C (122.0 °F)	910 Ω
60 °C (140.0 °F)	662 Ω
70 °C (158.0 °F)	489 Ω
80 °C (176.0 °F)	367 Ω
90 °C (194.0 °F)	279 Ω

- A. If ambient temperature sensor test is good, continue with step **3**.
 - B. If the ambient temperature sensor test fails, replace the sensor.
3. Check upstream and downstream temperature sensors. Disconnect the wiring harness from the upstream temperature sensor, connector **X905**. Use a multi-meter to measure the resistance on the upstream temperature sensor connector from pin 1 to pin 2. Use the chart below for specifications. Then disconnect the wiring harness from the downstream temperature sensor, connector **X906**. Use a multi-meter to measure the resistance on the upstream temperature sensor connector from pin 1 to pin 2. Use the chart below for specifications.

Wire harnesses - Electrical schematic sheet 06 (55.100.DP-C.20.E.06)
Wire harnesses - Electrical schematic sheet 07 (55.100.DP-C.20.E.07)
Wire harnesses - Electrical schematic sheet 12 (55.100.DP-C.20.E.12)

3335-Timeout Of CAN Message TSC1-PE Torque - When Inactive

Control Module : EDC

NOTE: When the cause of the error code has been rectified, clear the error code and test the system for normal operation.

Cause:

Possible failure modes:

1. Faulty harness
2. CAN BUS interference
3. Faulty engine controller

Solution:

1. Before proceeding clear the error code with the approved diagnostic equipment. Run the tractor under normal conditions and retest.
 - A. If the error code is not indicated, check that the system is operating correctly.
 - B. If the error code is indicated, continue to step **2**
2. Check for other CAN related error codes displayed.
 - A. If other error codes are displayed, continue to these tests.
 - B. If no other error codes are displayed, continue to step **3**
3. Check all power supplies and grounds to the controllers on the CAN BUS.
 - A. If a fault is indicated, repair or replace the harness as required.
 - B. If the power supplies and grounds are okay, download the correct level of engine controller software. If the fault re-occurs, remove and replace the engine controller.

Wire harnesses - Electrical schematic sheet 46 (55.100.DP-C.20.E.46)

Wire harnesses - Electrical schematic sheet 46 (55.100.DP-C.20.E.46)

13017-Supply Voltage 12VH1 - Voltage Too Low

T6.140 AutoCommand	NA
T6.150 AutoCommand	NA
T6.160 AutoCommand	NA

Control Module : UCM

NOTE: When the cause of the error code has been rectified, clear the error code and test the system for normal operation.

Possible failure modes:

1. Faulty battery
2. Faulty charging system
3. Faulty fuse F-065 (5A)
4. Faulty fuse F-053 (15A)
5. Faulty connector
6. Faulty harness
7. Faulty controller

Solution:

1. Before proceeding clear the error code with the approved diagnostic equipment. Run the machine under normal conditions and retest.
 - A. If the error code is not indicated, check that the system is operating correctly.
 - B. If the error code is indicated, continue to step **2**
2. Check the battery condition and terminal connections.
 - A. If the battery or terminals are faulty, repair or replace as required.
 - B. If the battery and terminals are okay, continue to step **3**
3. Check the battery voltage on the instrument cluster.
 - A. Start the engine and run at **2000 RPM**. If the voltage displayed is not between **12 - 15 V**, continue to test for a fault in the charging system.
 - B. If the battery voltage is okay, continue to step **4**.
4. Check fuses F-065 (5A) and F-053 (15A).
 - A. If the fuse(s) are blown, replace the fuse and retest.
 - B. If the fuse(s) are okay, continue to step **5**
5. Check the controller connector **X952**.
 - A. Ensure the connector is connected, not damaged, the pins are in the correct position and that the fit is tight. Repair or replace as required.
 - B. If the connector is okay, continue to step **6**
6. Check for **12 V**.
 - A. Disconnect the controller connector **X952**. Turn the keystore ON. Measure the voltage between connector:
 - X952** pin 2 (WH) and ground
 - X952** pin 3 (WH) and ground
 If approximately **12 V** is not indicated, repair or replace the harness as required.
 - B. If approximately **12 V** is indicated, remove and replace the controller.

CLICK HERE TO **DOWNLOAD** THE COMPLETE MANUAL

- Thank you very much for reading the preview of the manual.
- You can download the complete manual from: www.heydownloads.com by clicking the link below



- Please note: If there is no response to CLICKING the link, please download this PDF first and then click on it.

CLICK HERE TO **DOWNLOAD** THE COMPLETE MANUAL