

# FORD

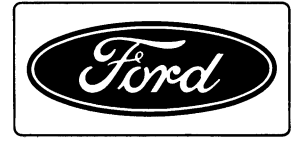

## Service Manual

---

Tractor  
250C, 260C

Tractor Loader  
345D, 445D, 545D

Section 1 – Engine Systems  
Section 2 – Fuel Systems  
Section 3 – Electrical System

Vol. 1

40025050A

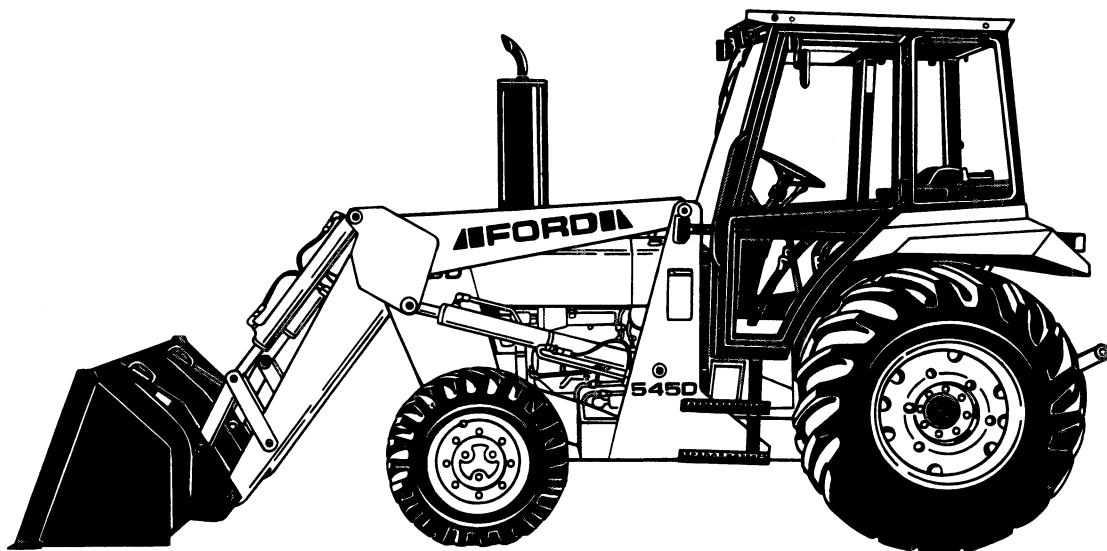

Reprinted

CLICK HERE TO **DOWNLOAD** THE COMPLETE MANUAL

- Thank you very much for reading the preview of the manual.
- You can download the complete manual from: [www.heydownloads.com](http://www.heydownloads.com) by clicking the link below



- Please note: If there is no response to CLICKING the link, please download this PDF first and then click on it.

CLICK HERE TO **DOWNLOAD** THE COMPLETE MANUAL

---

## **Cleanliness**

Cleanliness of the tractor hydraulic system is essential for optimum performance. When carrying out service and repairs, plug all hose ends and component connections to prevent dirt entry.

Clean the exterior of all components before carrying out any form of repair. Dirt and abrasive dust can reduce the efficiency and working life of a component and lead to costly replacement. Use of a high pressure washer or steam cleaner is recommended.

## **OPERATIONAL CONSIDERATIONS**

Stop the engine, if at all possible, before performing any service.

Place a warning sign on units which, due to service or overhaul, would be dangerous to start. Disconnect the battery leads if leaving such a unit unattended.

Do not attempt to start the engine while standing beside the unit or attempt to bypass the safety start switch.

Avoid prolonged running of the engine in a closed building or in an area with inadequate ventilation as exhaust fumes are highly toxic.

Always turn the radiator cap to the first stop, to allow pressure in the system to dissipate when the coolant is hot.

Never work beneath a tractor which is on soft ground. Always take the unit to an area which has a hard working surface.

If it is necessary to raise the tractor for ease of servicing or repair, be sure that safe and stable supports are installed, beneath axle housings, casings, etc., before beginning.

Certain repair or overhaul procedures may necessitate separating the tractor, either at the engine/front transmission or front transmission/rear transmission locations. These operations are simplified by the use of the tractor splitting kit/stands. Should this

equipment not be available, then every consideration must be given to stability balance and weight of the components, especially if a cab is installed.

Use footsteps or working platforms when servicing those areas of a tractor that are not within easy reach.

Before loosening any hoses or tubes connecting implements to remote control valves, etc., switch off the engine, remove all pressure in the lines by operating levers several times. This will remove the danger of personal injury by oil pressure.

Prior to pressure testing, be sure that all hoses and connectors, not only of the tractor, but also those of the test equipment are in good condition and tightly secured. Pressure readings must be taken with the gauges specified. The correct procedure should be rigidly observed to prevent damage to the system or the equipment, and to eliminate the possibility of personal injury.

When equipment or implements are required to be attached to the hydraulic linkage, either for testing purposes or for transportation, then "position control" should be used.

Always lower the loader and backhoe buckets to the ground or engage the safety locks before leaving the tractor.

If high lift attachments are mounted to a unit, beware of overhead power, electric or telephone cables when traveling. Keep the attachment near to ground level to increase stability.

Do not park or attempt to service a unit on an incline. If unavoidable, take extra care and block all wheels.

Prior to removing wheels and tires from a unit, check to determine whether additional ballast (liquid or weights) has been added. Seek assistance and use suitable equipment to support the weight of the wheel assembly.

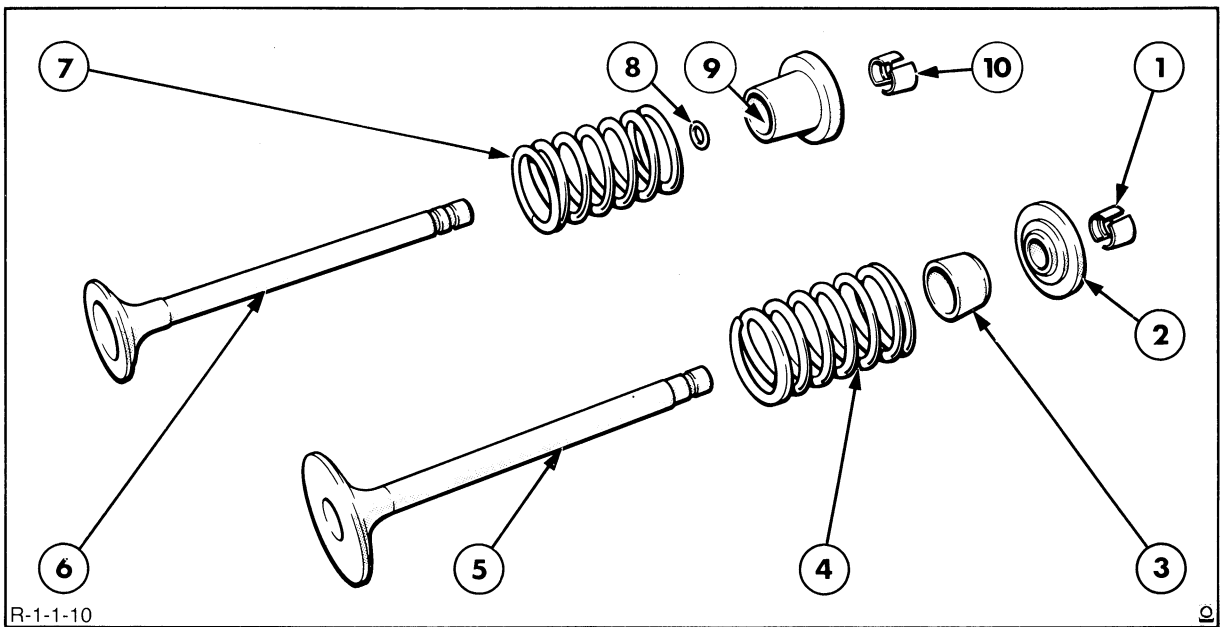

R-1-1-10

FIGURE 1-11

Valve Assembly Components

- |                                     |   |
|-------------------------------------|---|
| 1 Intake valve spring retainer lock | 6 Exhaust valve                             |
| 2 Intake valve spring retainer      | 7 Exhaust valve spring                      |
| 3 Intake valve seal                 | 8 Exhaust valve seal                        |
| 4 Intake valve spring               | 9 Exhaust valve spring retainer and rotator |
| 5 Intake valve                      | 10 Exhaust valve spring retainer locks      |

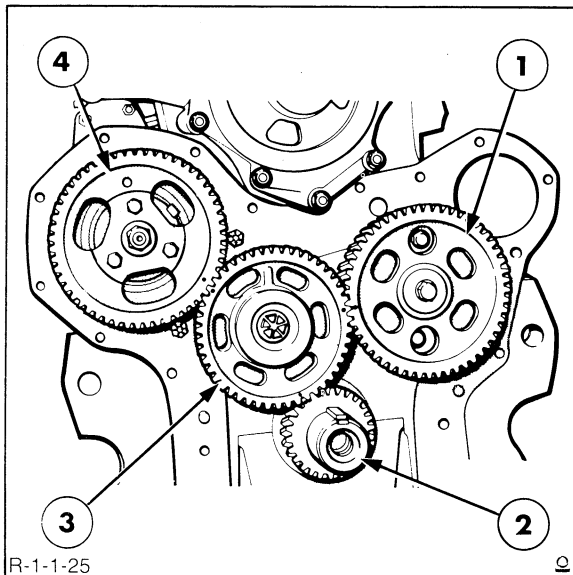

FIGURE 1-26

## Timing Gears

- 1 Camshaft gear
- 2 Crankshaft gear
- 3 Camshaft drive gear
- 4 Injection pump drive gear

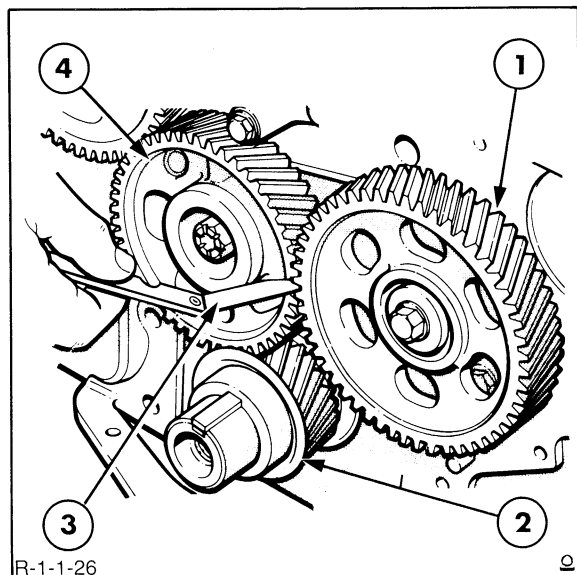

FIGURE 1-27

## Measuring Timing Gear Backlash

- 1 Camshaft gear
- 2 Oil slinger (reference only)
- 3 Feeler gauge
- 4 Camshaft drive gear

6. Remove the two bolts retaining the pump in the timing gear casing, then remove the pump from the engine and drain the remaining oil from the reservoir.
7. Remove the retaining bolts, then remove the front cover and gasket. Remove the oil slinger.
8. Before removing the timing gears, Figure 1-26, use a dial indicator or feeler gauges, to measure the backlash between each set of mating gears, Figure 1-27. Rotate the gears and check the backlash at four equidistant points on the gears. Replace the gears if the backlash exceeds the specified limits. Refer to the following specifications for gear backlash limits.

**CAMSHAFT DRIVE GEAR**

Backlash with crankshaft gear - 0.001 - 0.009" (0.025 - 0.23 mm).

Backlash with camshaft gear - 0.001 - 0.009" (0.025 - 0.23 mm).

Backlash with fuel injection pump drive - 0.001 - 0.012" (0.025 - 0.30 mm).

**CAMSHAFT GEAR**

Timing gear backlash - 0.003 - 0.008" (0.08 - 0.20 mm).

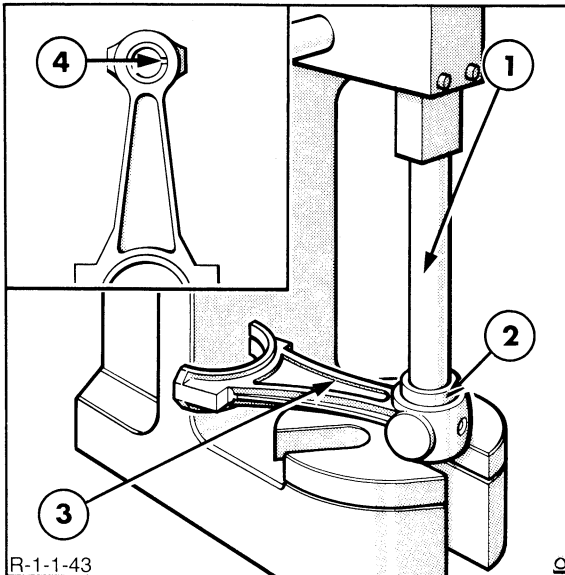

FIGURE 1-45

## Connecting Rod Bushing Removal And Installation

- 1 Handle tool no. 818 or FNH00514
- 2 Adaptor tool no. 818 or FNH09514
- 3 Connecting rod
- 4 Split in bush

4. Check the connecting rod components for damage and place each connecting rod in an alignment fixture to check for distortion.

**PISTON AND CONNECTING RODS**

Piston Ring Side Clearance	0.0024" - 0.004" (0.061 mm - 0.104 mm)
Connecting Rod Distortion	
Maximum Twist	0.0120" (0.30 mm)
Maximum Bend	0.0040" (0.10 mm)
Clearance Bushing-to-Piston-Pin	0.0005" - 0.0007" (0.013 mm - 0.018 mm)

5. Check the piston pin bushings for wear or damage. Measure the outside diameter of the piston pin and the inside diameter of the connecting rod bushing. If the clearance is not within the specified limits as shown in the previous table, press out the connecting rod bushing and install a new bushing using tool No. 818 or FNH09514 with a suitable adapter, Figure 1-45.

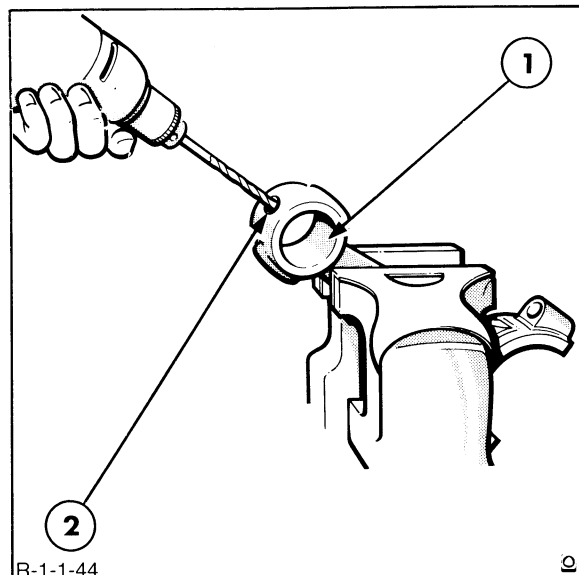

FIGURE 1-46

## Connecting Rod Bushing Installed

- 1 Connecting rod bush installed
- 2 Lubricating hole

**NOTE:** Line up the bushings so that the split is at right angles to the connecting rod's longest axis and ensure the bushing does not protrude from either side of the rod.

6. After installation of a new connecting rod bushing, use the hole in the top of the rod as a guide and drill a 0.25" (6.4 mm) diameter hole through one wall of the bushing, Figure 1-46.
7. Use an expansion reamer to ream the bushing to obtain the specified bushing-to-piston pin clearance. Remove burrs and metal chips from the rod before fitting the piston pin.

## CRANKSHAFT

### Removal

1. Remove the engine from the tractor, "Separating the Tractor" and place on an engine stand.
2. Remove the pressure plate and clutch disc assembly from the flywheel, see "Transmissions".
3. Remove the flywheel and engine rear cover plate as previously described in this section.
4. Remove the crankshaft pulley and engine front cover as previously described in this section.

**NOTE:** If the crankshaft is removed with the cylinder head in position, ensure all timing marks are realigned prior to reassembly. This action will prevent possible interference between the valves and pistons during reassembly.

5. Remove the oil pan sump, the oil pump and intermediate shaft as previously described in this section.
6. Remove the connecting rod and main bearing caps and liners and identify to facilitate reassembly.
7. Carefully lift the crankshaft out of the cylinder block.

### Inspection and Repair

**NOTE:** Current production engines may have a crankshaft with main or crankpin journals ground 0.010" (0.25 mm) undersize. These are identified with the letters "010 MUS" and/or "010 PUS" respectively. The letters are stamped on one of the crankshaft counterbalance weights.

1. If the crankshaft gear teeth are excessively worn or chipped, install a new crankshaft gear which must be fully located on the shoulder of the crankshaft.

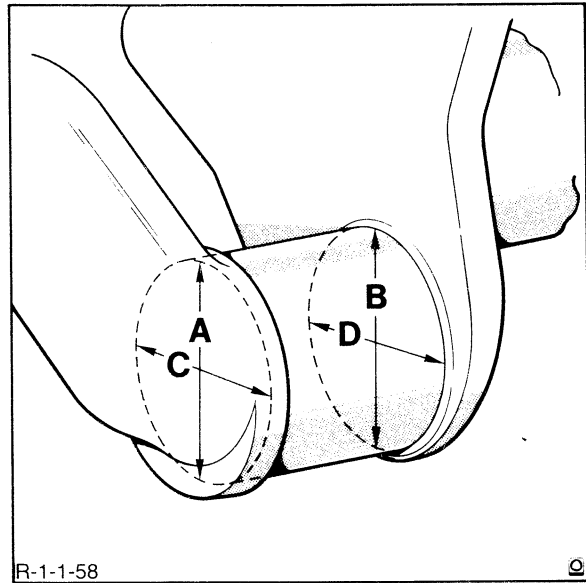

FIGURE 1-60

Crankshaft Journal Measurements

2. Clean the crankshaft and drilled passages. Dress minor imperfections with an oil stone and refinish severely marked journals to the next undersize bearing.
3. Measure the diameter of each journal in four places to determine out-of-round, taper or wear, Figure 1-60. Measurement "A" compared with "B" indicates vertical taper, while measurement "C" compared with "D" indicates horizontal taper. Measurements "A" and "B" compared with "C" and "D" indicate journal out-of-round.

If the journal exceeds the specified wear limit (0.005"), refinish the journals to the next undersize bearing as shown in the following table:

4. Examine the rear oil seal journal for score marks, remove minor imperfections with fine emery cloth, and if severely damaged, replace the crankshaft.

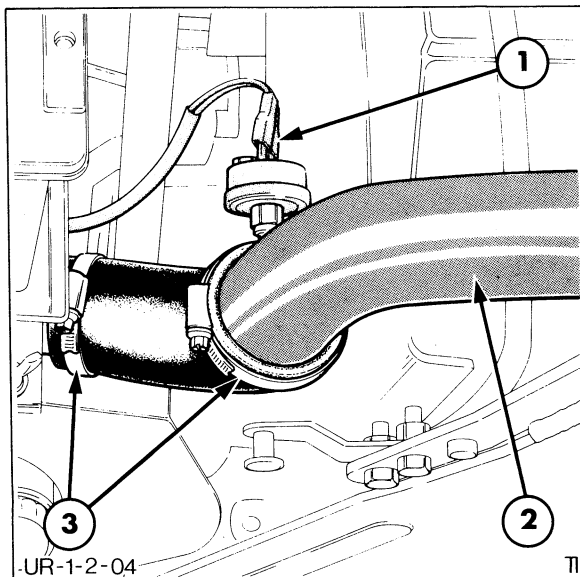

FIGURE 1-74

## Air Cleaner Hoses - Removal

- 1 Air cleaner restriction switch wires
- 2 Air cleaner outlet tube
- 3 Hose clamps

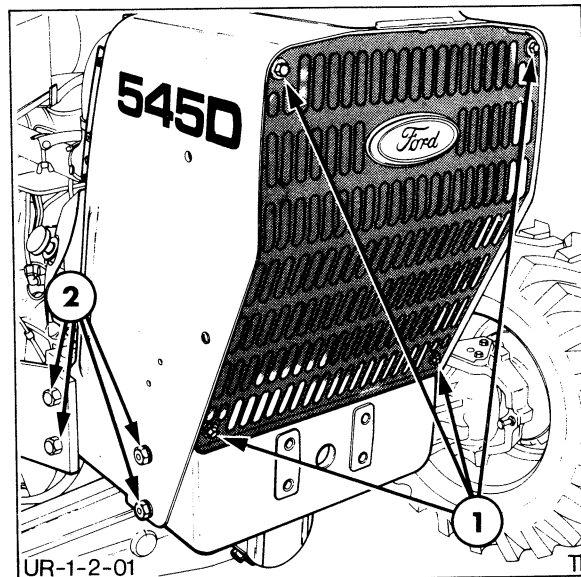

FIGURE 1-75

## Radiator Shell Removal

- 1 Radiator grille bolts
- 2 Radiator shell retaining bolts

7. Disconnect the air cleaner restriction switch wires, Figure 1-74.
8. Loosen the hose clamps and disconnect the air cleaner outlet tube at the hose connection to the intake manifold, Figure 1-74.
9. Loosen the radiator shell support bolts, Figure 1-75.

**NOTE:** If tractor is equipped with a loader, support the loader frame side rails.

10. Using suitable lifting equipment, support the radiator shell, then remove the radiator shell lower retaining bolts.
11. Remove the radiator shell with the reservoir and air cleaner as an assembly.
12. Disconnect the upper and lower radiator hoses, Figure 1-76.
13. Remove the fan shroud bolts from the radiator.
14. Remove the radiator base support bolts and lift the radiator out of the tractor.

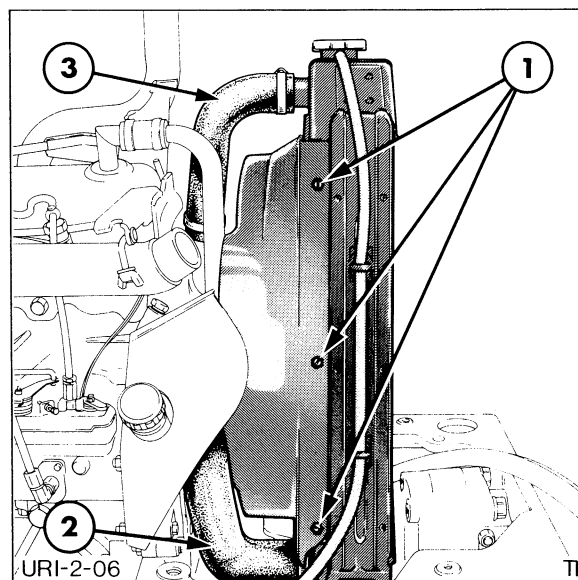

FIGURE 1-76

## Radiator Hoses Removal

- 1 Fan shroud retaining bolts
- 2 Lower radiator hose
- 3 Upper radiator hose

SECTION 1 – ENGINE SYSTEMS

PROBLEM	POSSIBLE CAUSES	CORRECTION
Oil pressure warning light fails to operate	Bulb burnt out Warning light pressure switch faulty Warning light circuit faulty	Replace bulb Replace pressure switch Check and replace wiring
Excessive exhaust smoke	Exhaust leak on exhaust manifold side of turbocharger, where fitted Air cleaner dirty or restricted Excessive fuel delivery	Install new gasket Clean Overhaul injection pump/injectors
Water temperature gauge fails to reach normal operating temperature	Faulty temperature sender switch Incorrect or faulty thermostat Faulty water temperature gauge	Replace sender switch Replace thermostat Replace temperature gauge

**OIL PUMP**

Rotor Clearance	0.001" - 0.006" (0.025 mm - 0.15 mm)
Rotor-to-Pump Housing Clearance	0.006" - 0.011" (0.15 mm - 0.28 mm)
Rotor End Play	0.001" - 0.0035" (0.025 mm - 0.089 mm)
Relief Valve Pressure	60-70 lbf/in <sup>2</sup> (4.1 bar - 4.8 bar) (4.2 kg/cm <sup>2</sup> - 4.9 kg/cm <sup>2</sup> ) at 2000 rev/min
Relief Valve Spring Tension	1.07" (27.2 mm) under 10.7 lb. - 11.9 lb. (4.85 kg - 5.4 kg) load

Temperature	Oil Viscosity and Type	API Classification	Engine Oil & Filter Change Period (hours)
Below -12° C. (10° F.)	Low Ash, SAE 5W Supplement 1 or Low Ash SAE 5W/20 Supplement 1 or SAE 10W-30	CC	150
		CC	150
		CD	150
-12° C. to 4° C. (10° F. to 40° F.)	Low Ash, SAE 10W Series 3 or SAE 10W-30	CD	300
		CD	300
0° C. to 32° C. (32° F. to 90° F.)	Low Ash, SAE 20 Series 3 or SAE 10W-30	CD	300
		CD	300
Above 24° C. (75° F.)	Low Ash, SAE 30 Series	CD	300

**NOTE:** When using diesel fuel with a sulphur content below 1.0% Series 3 diesel engine oil with an A.P.I. classification of CC may be used instead of CD oil, but the oil and filter change interval must be reduced to 150 hours.

When using diesel fuel with sulphur content between 1% and 1.3% use only oils listed above but reduce the oil and filter change period to every 50 hours.

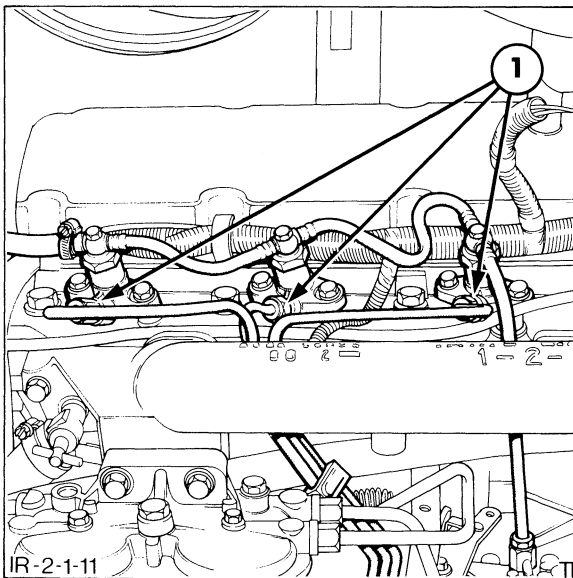

FIGURE 2-9

## Fuel Injector Line Connections

- 1 Injector connections

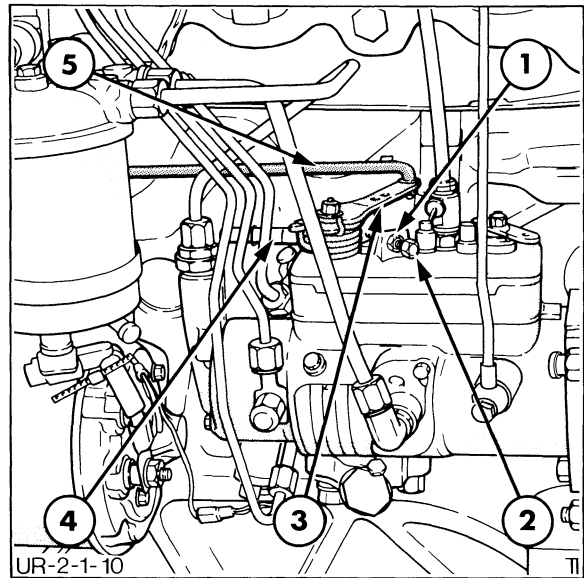

FIGURE 2-10

## Fuel Injection To Pump Adjustment

- 1 Idle stop locknut
- 2 Idle stop screw
- 3 Throttle lever
- 4 Locking sleeve
- 5 Throttle rod

4. Loosen the injector line connections, Figure 2-9. Continue to crank the engine until air-free fuel is discharged from the connections. Tighten each connection in turn while the engine is still cranking.
5. Run the engine and check for leaks.

**IDLE SPEED ADJUSTMENT**

1. With the engine running and at normal operating temperature, disconnect the throttle linkage at the injection pump, Figure 2-10.
2. Loosen the locknut and adjust the idle speed stop screw until a 680-850 RPM idle speed is obtained, and reconnect the throttle linkage.
3. Operate the throttle several times and check that the idle speed obtained corresponds with the reading in step 2.

**MAXIMUM NO-LOAD SPEED ADJUSTMENT**

*IMPORTANT: The maximum no-load speed screw is adjusted and sealed at the factory for correct fuel delivery and maximum no-load speed. If the maximum no-load speed is above or below the specified range, then adjustment may be made as follows:*

1. With the engine running and at normal operating temperature, disconnect the throttle linkage at the fuel injection pump, Figure 2-10.
2. Cut and remove the maximum no-load speed stop screw sealing wire and remove the locking sleeve.
3. Set the throttle lever at the injection pump to the maximum no-load speed position, then loosen the locknut and adjust the screw until a maximum no-load speed between 2350-2400 RPM is obtained. Tighten the locknut, and secure the adjustment with a new sealing wire and locking sleeve.

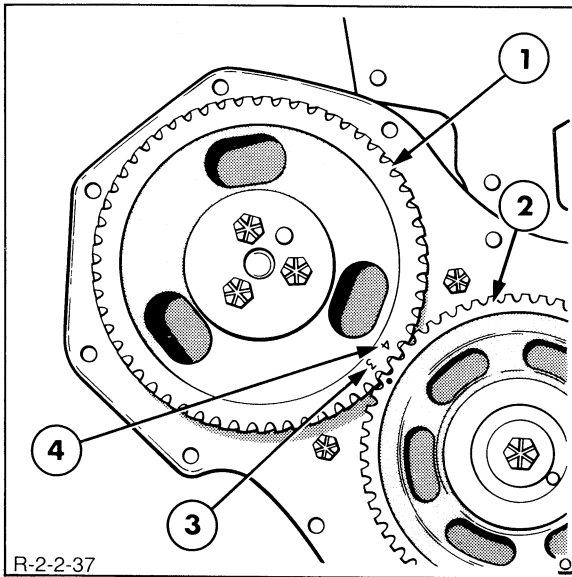

FIGURE 2-22

## DPA Injection Pump Drive Gear Timing

- 1 Pump drive gear
- 2 Camshaft drive gear
- 3 3-Cylinder timing mark
- 4 4-Cylinder timing mark

**INJECTION PUMP INSTALLATION**

1. Place a new O ring on the pump mounting flange.
2. If the pump timing cover is in position on the engine front cover, it should be removed.
3. Ensure that the injection pump drive gear is correctly meshed with the camshaft drive gear so that the timing marks are aligned, Figure 2-22.

**NOTE:** All engines with a DPA distributor type fuel injection pump have a common fuel injection pump drive gear. This gear features two timing marks identified by numerals "3" and "4" for 3 and 4-cylinder engines respectively.

4. Install the injection pump, making sure that the drive hub dowel pin engages with the hole in the drive gear - turn pump drive shaft as necessary, then secure pump loosely to the engine front plate with the three securing bolts.
5. If the pump has been internally timed, rotate the pump clockwise, as viewed from the rear end, 1/2 a division relative to the zero degree mark on the rear of the engine front plate.
6. If the pump has not been internally timed, aligned the scribed line on the pump flange with the center punch reference mark previously made on the rear of the engine front plate.
7. Tighten the injection pump retaining bolts to 18 ft. lbs. (24 N·m) torque.
8. Insert the three drive gear securing bolts and tighten to 22 ft. lbs. (30 N·m) torque.
9. Connect all fuel pipes, electrical solenoid wire and throttle control rods or cables to the injection pump.
10. Install the pump timing cover into the engine front cover, using a new gasket, and tighten the retaining screws.
11. Bleed the fuel system as follows:
  - a. Make sure there is sufficient fuel in the tank and all connections are tight.
  - b. Remove the bleed screw from the top of the filter and allow the fuel to flow until it is free from air bubbles. Install the bleed screw and tighten.
  - c. Loosen the bleed screw on the injector pump and crank the engine until the fuel flowing is free from air bubbles. Tighten the bleed screw.
  - d. Loosen the injector line connectors at the injectors and crank the engine with maximum throttle until fuel free from air bubbles flows. Tighten the connectors.

# INJECTORS

## DESCRIPTION AND OPERATION

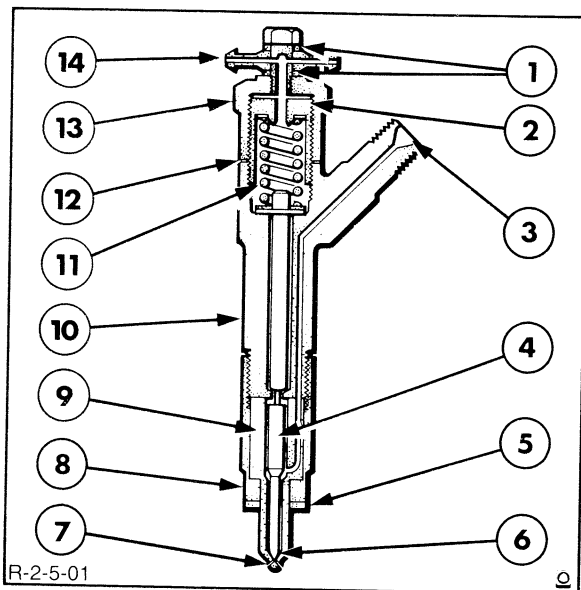

FIGURE 2-23

### Fuel Injector Assembly

- 1 Washers
- 2 Spring adjusting nut
- 3 Fuel inlet
- 4 Needle valve
- 5 Washer
- 6 Needle valve seat
- 7 Nozzle tip
- 8 Nozzle retaining nut
- 9 Nozzle body
- 10 Nozzle holder
- 11 Spring
- 12 Copper washer
- 13 Cap nut
- 14 Leak-off line connector

The engine injector function is to inject fuel into a pressurized cylinder in a fully atomized condition so as to burn efficiently with a minimum of smoke.

Each injector consists of a nozzle assembly, containing a needle valve, and a nozzle holder assembly housing the injector needle valve regulating spring, Figure 2-23.

Fuel from the fuel injection pump enters the injector fuel inlet and passes down through a drilling in the nozzle holder and body to the needle valve seat.

The fuel, pressurized by the injection pump, lifts the needle valve off the seat against the action of a spring. The fuel is then forced, in an atomized state, through the four holes in the nozzle tip. When the pressure from the injection pump drops, the needle valve snaps back onto the seat under pressure from the spring.

To provide lubrication of the injector, a small amount of fuel is permitted to leak up between the needle valve and the nozzle body. The excess fuel rises to the top of the injector and returns to the fuel tank via an injector leak-off line.

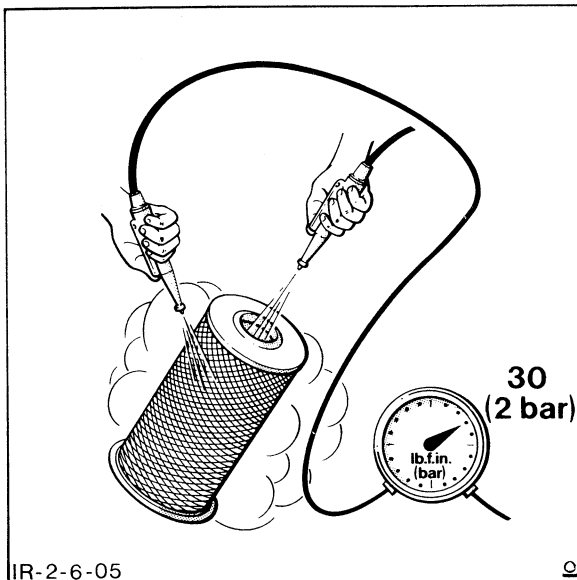

FIGURE 2-43

Cleaning Element With Compressed Air

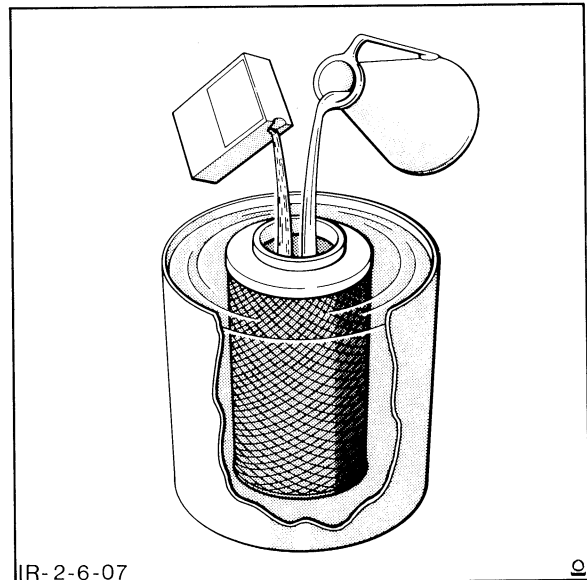

FIGURE 2-44

Washing The Element

## INSPECTION AND REPAIR

1. Clean and examine the outer casing. Repair any damaged seams.
2. Check the condition and security of the rubber dust collector.
3. If dust is present inside the outer element, it must be replaced. If satisfactory, clean the element by tapping both ends on the palm of the hand. Do not tap the element against a hard surface as it will be damaged or distorted.
4. Alternatively, compressed air, not exceeding 30 lbf/in<sup>2</sup> (2 bar) may be used. Insert the air line nozzle inside the element and blow the dust from the inside to the outside. Blow loose particles from the outside of the element by holding the nozzle at least 6" (150 mm) from the element. Protect the eyes when carrying out this operation.
5. If undamaged, wash the element every 300 hours or after five dry cleanings, whichever occurs first using the following procedure.
 

*IMPORTANT: Never use fuel oil, gas, solvent or water hotter than the hand can stand, otherwise the element may be damaged.*

  - a. Washing the element. Seal the small hole at the closed end of the filter with a strip of adhesive tape and place the filter, open end up, in a deep flat bottomed container or tube. Add a small amount of non-sudsing washing powder (automatic washing machine type) to the inside of the filter element. Add warm water, 100 degrees F (35 degrees C), to the inside of the element until the level in the container is just below the open end of the element. Allow the element to soak for at least 15 minutes (but never more than 24 hours) in the cleaning solution.

**FUEL INJECTION PUMP – DPA DISTRIBUTOR TYPE**

<b>DESCRIPTION</b>	<b>ft. lbs.</b>	<b>N·m</b>	<b>Kgf m</b>
End Plate Screws	3.4	5	0.5
Fuel Inlet Connections	30	40	4.1
Transfer Pump Rotor	5	7	0.7
Head Locking Screws	14	19	1.9
Advance Device Cap Nut	9	12	1.2
Cam Advance Screw	33	45	4.6
Head Location Fitting	29	39	4.0
Advance Device Spring and Piston End Caps	21	29	3.0
Fuel Connection Studs (Banjo and Radial)	23	31	3.2
Governor Control Cover Studs	5	7	0.7
Governor Control Cover Cup Nuts	3	4	0.4
Head Locating Fitting End Nut	17	23	2.4
Governor Control Bracket Screw	2	3	0.3
Throttle and Shutoff Shaft Retaining Nuts	2.5	3.5	0.4
Drive Hub Screw (Slacken and retighten to this torque three times after testing pump)	27	37	3.7
Drive Plate Screws (First tighten to high torque figure then slacken and retighten to low torque figure)	29 (21)	39 (28)	4.0 (2.9)
Governor Weight Carrier Securing Screws	9	12	1.2
Delivery Valve Holders	42	57	5.8
Pump Drive Gear Retaining Bolts	22	30	3.1
Governor Spring Retaining Bolt	3	4	0.4
Control Fork Socket Screws	2	3	0.3
Injector Nozzle Retaining Nut	50	70	7.1
Injector Retaining Bolts	17	22	2.2
Injector Leak-Off Line Banjo Bolts	10	12	1.2
Injector Cap Nut	50	70	7.1
High Pressure Gland Nuts at Injector	23	32	3.3
High Pressure Gland Nuts at Fuel Injection Pump	23	32	3.3
Injection Pump Retaining Bolts	18	24	2.4

### **Engine Coolant Temperature Gauge**

Indicates the temperature of the engine coolant. If the needle enters the red sector while the engine is running, stop the engine and investigate the cause.

**NOTE: When the key-start/stop switch is turned off, the gauge needle assumes a random position.**

### **Engine Oil Pressure Warning Light**

Indicates low oil pressure and should go off immediately after the engine starts.

*IMPORTANT: If the light comes on while the engine is running, stop the engine and investigate the cause.*

### **Power Reversing Transmission Temperature Warning Light**

The power reversing transmission warning light indicates overheating of the oil in the transmission. Do not operate the transmission if the light comes on. Check that the oil level is correct, place the transmission in neutral and run the engine at 1000-1200 RPM until the warning light goes out.

### **Air Cleaner Restriction Warning Light**

Will light when the air cleaner requires servicing. If the light comes on while the engine is running, stop the engine and service the air cleaner.

**NOTE: When the key-start switch is turned to "ON" the light will come on to indicate that the lamp is functioning. The light will go off with the engine running and the air cleaner functioning correctly.**

The air cleaner warning light is connected into the oil pressure warning light circuit. In the event of low oil pressure, both the air cleaner and oil pressure warning lights will come on.

### **Alternator Warning Light**

Indicates the battery is not being charged and should go off when the engine speed is increased above idle.

### **Fuel Gauge**

Indicates the level of fuel in the tank and is only operative with the key-start switch in the "ON" position.

### **Diodes**

For all models with a dry type air cleaner, the oil pressure sender and air cleaner restriction warning light circuits are interconnected by a diode.

This system provides a check facility for the warning bulbs. When the key-start/stop switch is actuated, both the oil pressure and the restriction warning lights come on. Once the engine has started and the correct oil pressure established, both warning lights should go off.

However, if the air cleaner is restricted, then the bulb is grounded through the restriction vacuum switch and remains on.

**NOTE: When the oil pressure is low, both the oil pressure and the air cleaner restriction warning lights come on.**

**TESTS**

Before commencing battery tests, check the battery for clogged vents, corrosion, raised cell covers or a cracked case. The following tests are performed using a hydrometer, a battery starter tester (high-rate discharge tester) and a battery charger.

Specific Gravity - This test will determine the state of battery charge. Proceed as follows:

1. With the float in the vertical position, take the reading at the level of the bottom of the curved portion of the liquid.
2. Adjust the hydrometer reading for electrolyte temperature variations by subtracting four points (0.004 specific gravity) for every 10 degrees F (5.5 degrees C) below the temperature at which the hydrometer is calibrated and by adding four points (0.004 specific gravity) for every 10 degrees F (5.5 degrees C) above this temperature.

The following are examples using a hydrometer calibrated at 86 degrees F (30 degrees C).

Example 1:

Temperature below 86° F (30° C)  
 Electrolyte temperature 66° F (19° C)  
 Hydrometer reading 1.270  
 Subtract  $\frac{11.00}{5.5} \times 0.004$  0.008

Corrected Specific Gravity 1.262

Example 2:

Temperature above 86° F (30° C)  
 Electrolyte temperature 104° F (40° C)  
 Hydrometer reading 1.270  
 Subtract  $\frac{10.00}{5.5} \times 0.004$  0.007

Corrected Specific Gravity 1.277

3. Use the following table to determine the state of charge:

State of Charge	Corrected Specific Gravity
100 %	1.280
75 %	1.230
50 %	1.180
25 %	1.130
Discharged	1.080

**NOTE: Specific gravity should not vary more than 0.025 points between cells.**

4. If the specific gravity is 1.280 or more, the battery is fully charged.
5. Should the corrected specific gravity be below 1.280, charge the battery and inspect the charging system to determine the cause of low battery charge.

**NOTE: If distilled water has recently been added, the battery should be put to work for a short period, otherwise accurate hydrometer readings will not be obtained.**

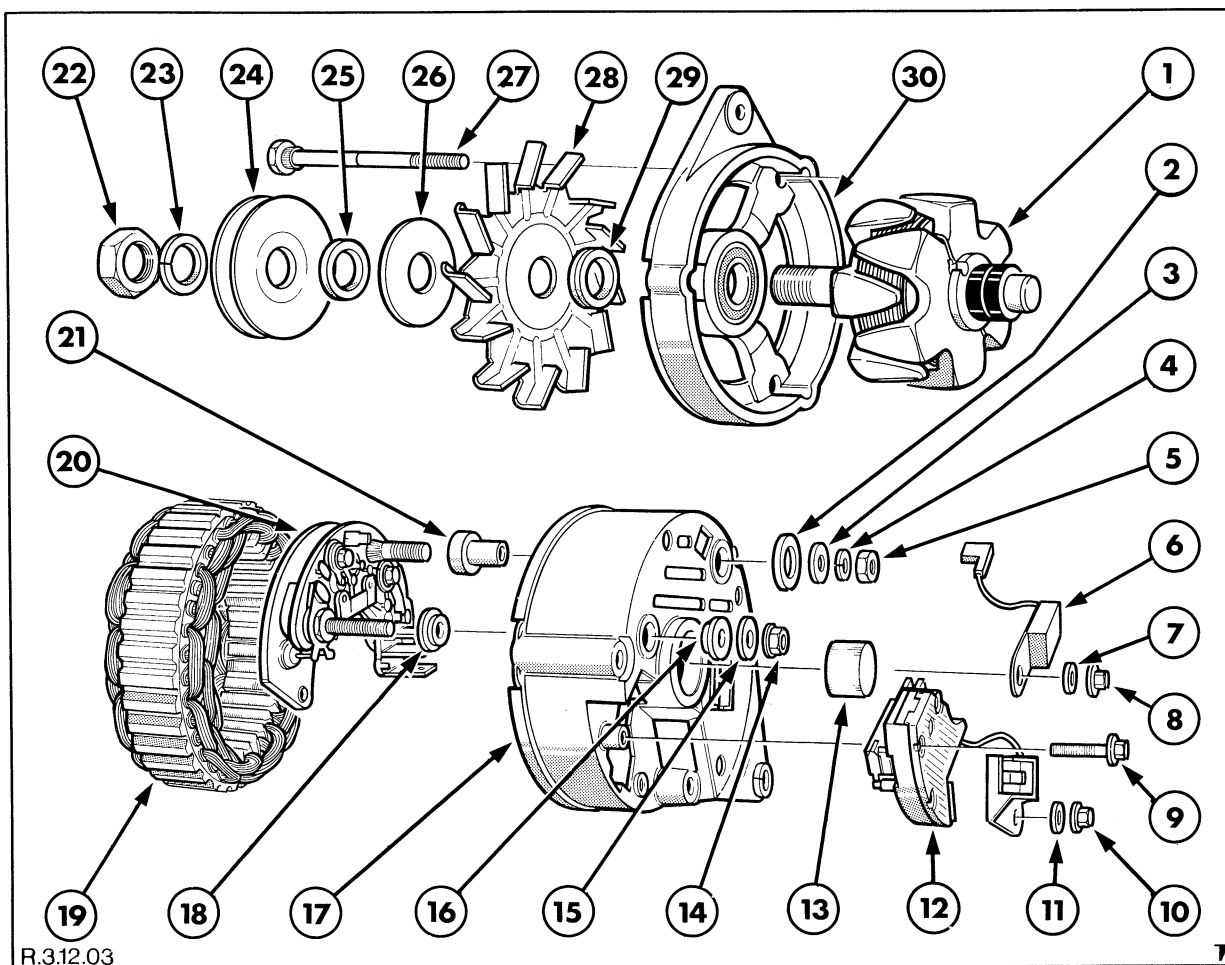

R.3.12.03

FIGURE 3-32

Alternator Components

- |                       |                     |
|-----------------------|---------------------|
| 1 Rotor               | 16 Insulator        |
| 2 Insulator           | 17 Rear end bracket |
| 3 Washer              | 18 Insulator        |
| 4 Spring washer       | 19 Stator           |
| 5 Nut                 | 20 Rectifier        |
| 6 Suppressor          | 21 Insulator        |
| 7 Washer              | 22 Nut              |
| 8 Nut                 | 23 Washer           |
| 9 Bolt                | 24 Pulley           |
| 10 Nut                | 25 Spacer           |
| 11 Washer             | 26 Washer           |
| 12 Regulator/brushbox | 27 Through bolt     |
| 13 Bearing            | 28 Fame             |
| 14 Nut                | 29 Double spacer    |
| 15 Washer             | 30 End bracket      |

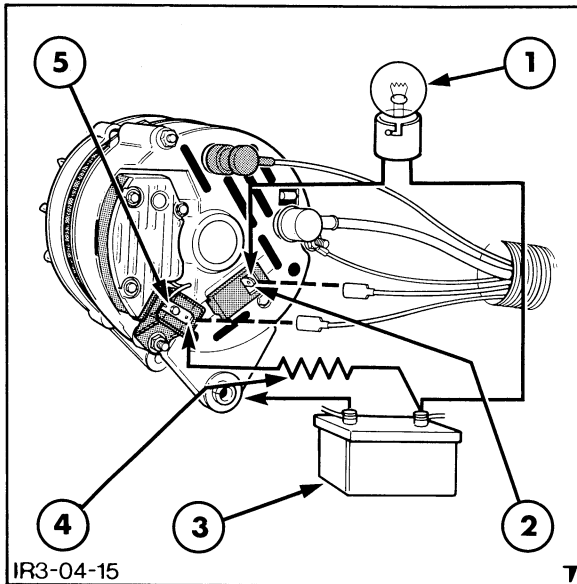

FIGURE 3-42

**Regulator And Rotor Field Circuit Test**

- 1 2.2 Watt test lamp
- 2 IND (indicator) terminal
- 3 12 volt battery
- 4 205 Ohm resistor
- 5 Sensor terminal

**Regulator and Rotor Field Circuit Test**

Refer to Figure 3-42.

1. Connect a 12 volt battery and a 2.2 watt test lamp in series between the "IND" (indicator) terminal and the alternator frame (negative side to frame).
2. Connect a 205 ohm resistor between the positive terminal of the battery and the sensor terminal.

The test lamp should be on. If the test lamp is not on, a fault is indicated in the rotor circuit. Check brushes, slip rings and continuity of rotor field windings.

If examination indicates these parts are satisfactory, the regulator is suspect.

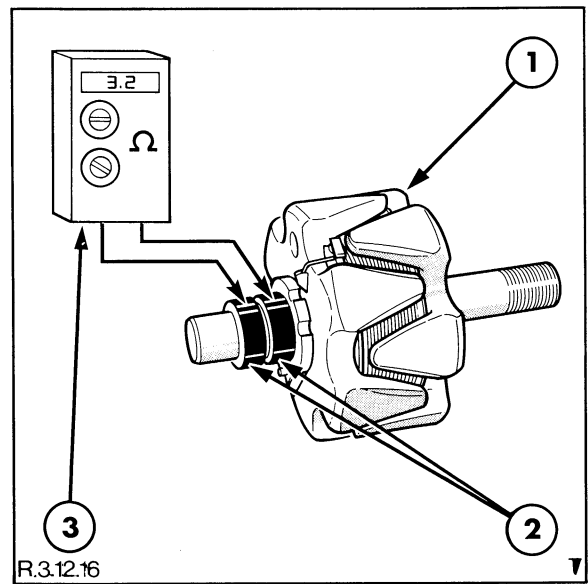

FIGURE 3-43

**Rotor Field Winding Continuity Test**

- 1 Rotor
- 2 Slip rings
- 3 Ohmmeter

**Rotor Field Winding Continuity Test**

Refer to Figure 3-43.

1. Remove the regulator and brushbox assembly as described in this Section.
2. Connect an ohmmeter between the two slip rings. The resistance should read 3.2 ohms.

If the resistance is outside of the specification, replace the rotor as detailed in the following Overhaul Section.

## QUICK TEST 1

## A. PRELIMINARY TEST (ENGINE OFF)

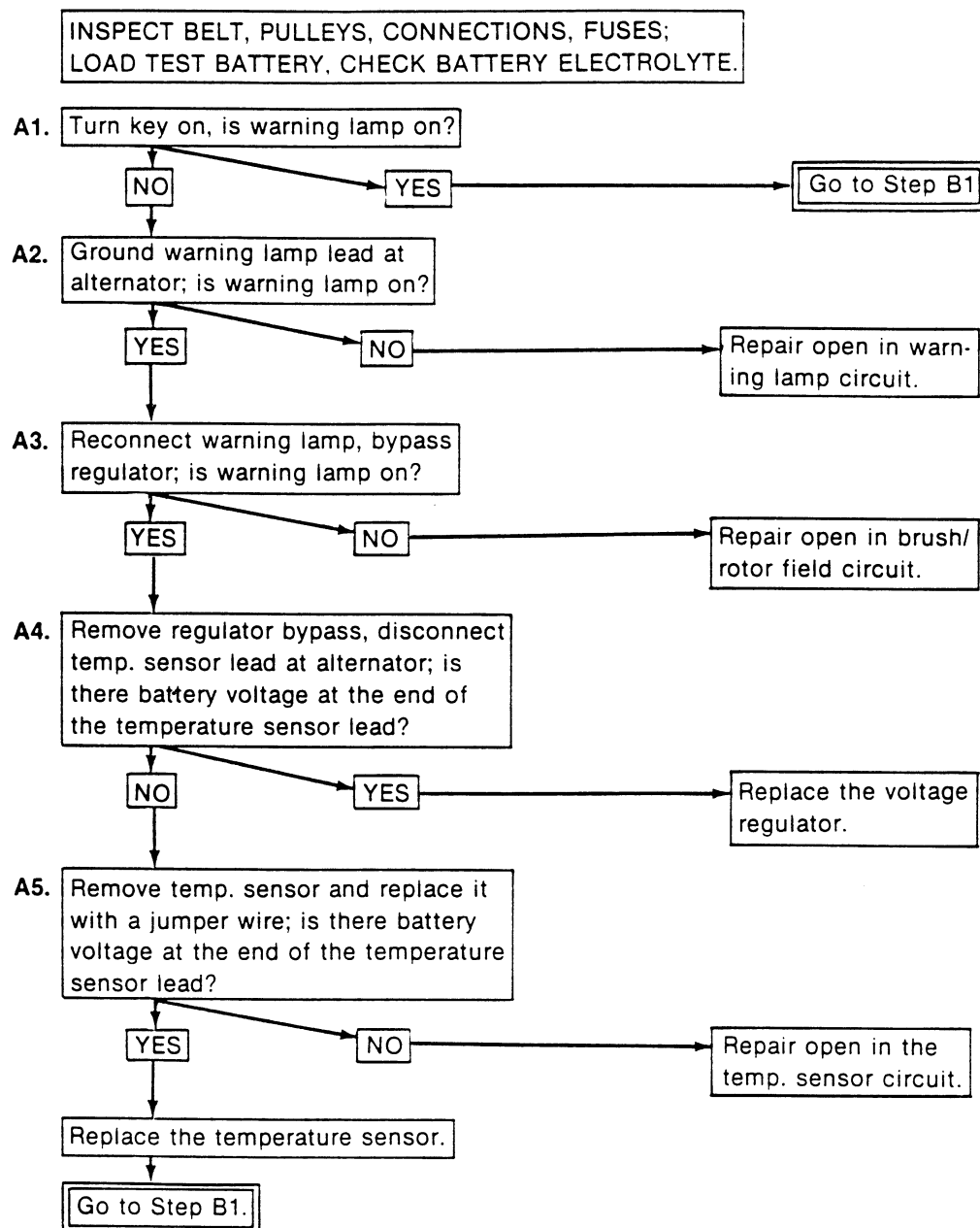

SECTION 3 - ELECTRICAL SYSTEM

---

The following general nut and bolt installation torque requirements (lubricated) apply to any operation not previously listed.

Size	ft. lbs.	N·m	Kgf m
<b>METRIC BOLTS</b>			
M4	2	2.7	0.28
M5	4.0-4.5	5.0-6.2	0.55-0.62
M6	6-8	8.5-10.6	0.9-1.1
M8	16-18.5	21-25	2.2-2.5
M10	30-37	41-51	4.2-5.1
M12	52-66	70-90	7.2-9.1
<b>INCH BOLTS</b>			
6-32	1	1.4	0.14
6-40	1	1.5	0.15
8-32	1.5-2.0	2.1-2.9	0.21-0.28
8-36	1.5-2.0	2.1-3.1	0.21-0.28
10-24	2-3	3.0-4.2	0.28-0.41
10-32	2.5-3.5	3.3-4.8	0.35-0.48
1/4-20	5-7.5	6.8-10.1	0.7-1.0
1/4-28	6-8	7.8-11.6	0.8-1.1
5/16-18	11-15	15-20	1.5-2.0
5/16-24	12-16	17-21	1.6-2.2
3/8-16	20-26	28-35	2.8-3.5
3/8-24	21-29	29-39	2.9-4.0

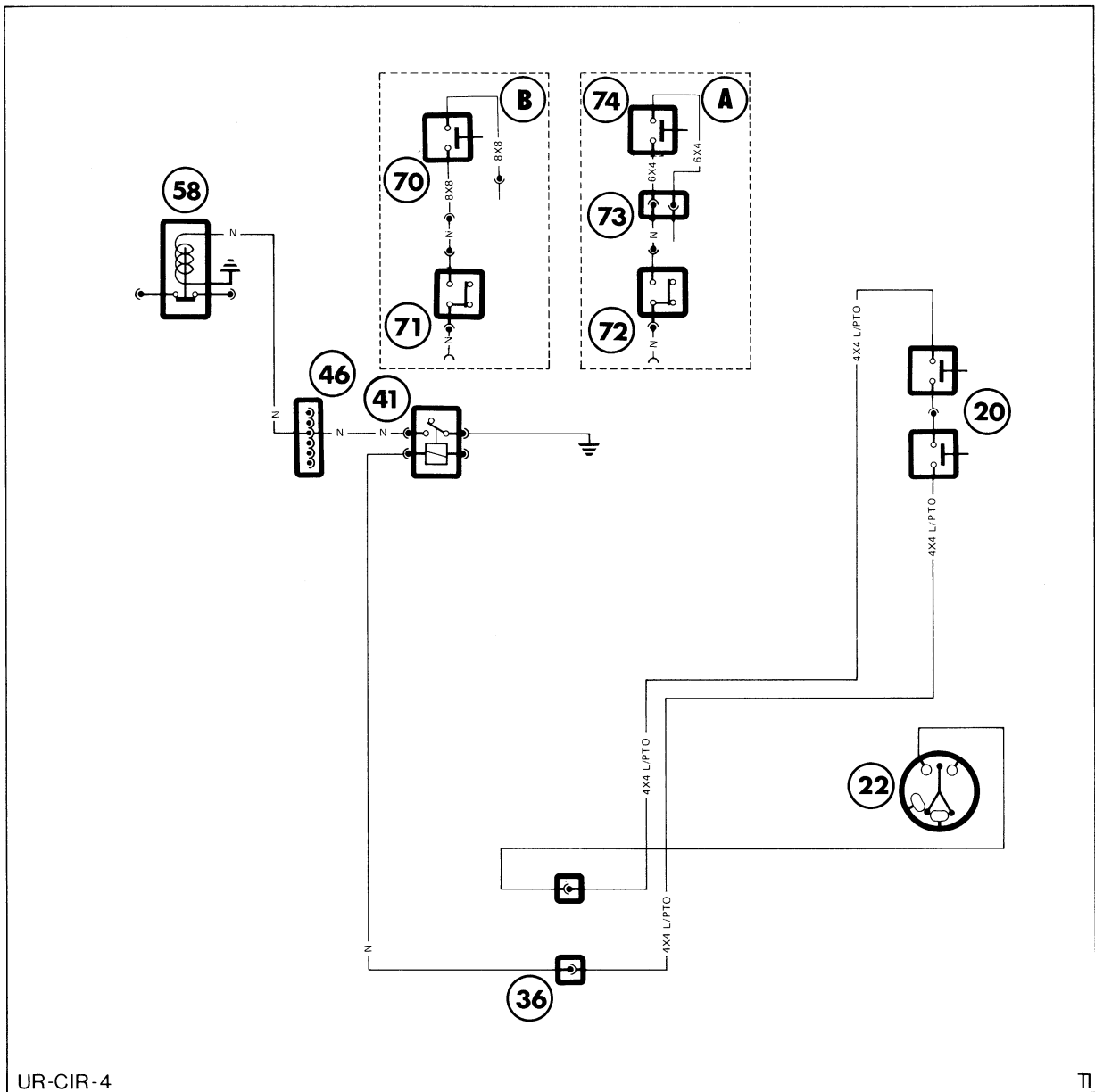

UR-CIR-4

TI

FIGURE 3-62

Engine Cranking Circuit

- |   |   |
|---|---|
| 20 Transmission - safety start switches (4 x 4) | 71 Transmission safety start switch 8 x 8 |
| 22 Key-start/stop switch                        | 72 PTO safety switch                      |
| 36 Safety start connectors                      | 73 Connector                              |
| 41 Starter relay                                | 74 Transmission safety switch 6 x 4       |
| 46 Main connector                               |   |
| 58 Starter solenoid                             | A 6 x 4 Transmission safety circuit       |
| 70 PTO safety start switch                      | B 8 x 8 Transmission safety circuit       |

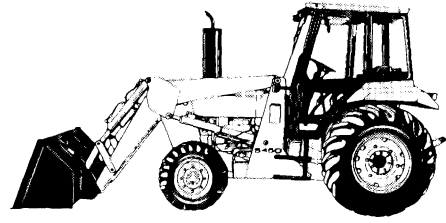

**NEW HOLLAND**

**250C 260C**

**345D 445D**

**545D**

Section 4 – Transmission

Section 5 – Rear Axle and Brakes

Section 6 – Power Take-Off

Section 7 – Steering and Front Axle

Vol. 2

**REPAIR  
MANUAL**



When the engine is running, the oil in the converter flows from the impeller to the turbine and back to the impeller through the stator. This flow produces a maximum torque increase of about 2.83 when the turbine is "stalled". When enough oil flow is developed by the impeller, the turbine begins to rotate, driving the front input shaft. The torque multiplication gradually decreases as turbine speed approaches impeller speed, and becomes 1 to 1 when the turbine is being driven at nine tenths impeller speed.

When the turbine is rotating at approximately nine tenths impeller speed, the converter stops multiplying torque because the oil is now acting on the rear face of the stator blades. The action of the oil on the rear face of the stator unlocks the one-way clutch, permitting the stator to rotate in the same direction as the turbine and impeller. Through this action the converter becomes an efficient fluid coupling by transmitting engine torque from the impeller to the turbine.

When the turbine is rotating less than nine tenths impeller speed, the converter is multiplying torque through the action of the stator. This action, produced by oil acting on the front face of the stator blades, tends to rotate the stator in the opposite direction of the impeller and turbine. However, the one-way clutch prevents this opposite rotation and allows the stator to direct oil back to the impeller, thereby producing torque multiplication.

### OIL DISTRIBUTOR

The oil distributor, Figure 4-6, consists of a pressure regulating valve, a bypass valve, the hydraulic pump and a series of oil passages for oil distribution.

Oil from the hydraulic pump enters the distributor, under pressure through the inlet passage, and is directed to the pressure regulating valve and bypass valve by means of internal passages. Additional passages then direct the oil to the solenoid control valve and torque converter.

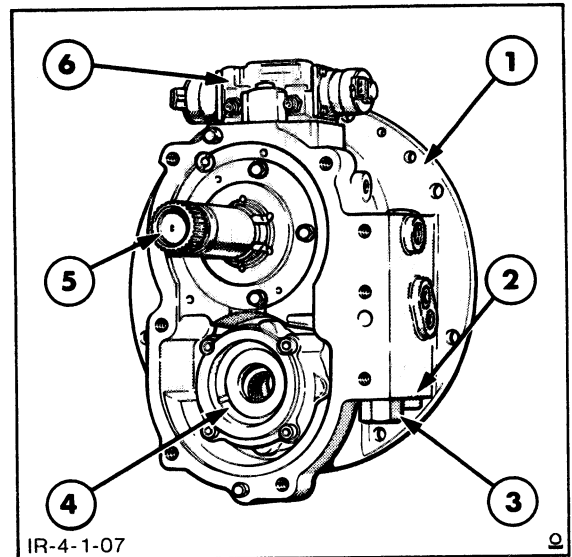

FIGURE 4-6

#### Oil Distributor

- 1 Oil distributor housing
- 2 Regulating valve
- 3 Bypass valve
- 4 Hydraulic pump
- 5 Stator support
- 6 Control valve

The bypass valve, working in conjunction with the pressure regulating valve, bypasses oil back to sump thereby limiting the maximum oil pressure for the torque converter.

The pressure regulating valve regulates oil pressure to the control valve which, in turn, directs this pressure regulated oil to the hydraulic clutch assemblies.

SECTION 4 - TRANSMISSION

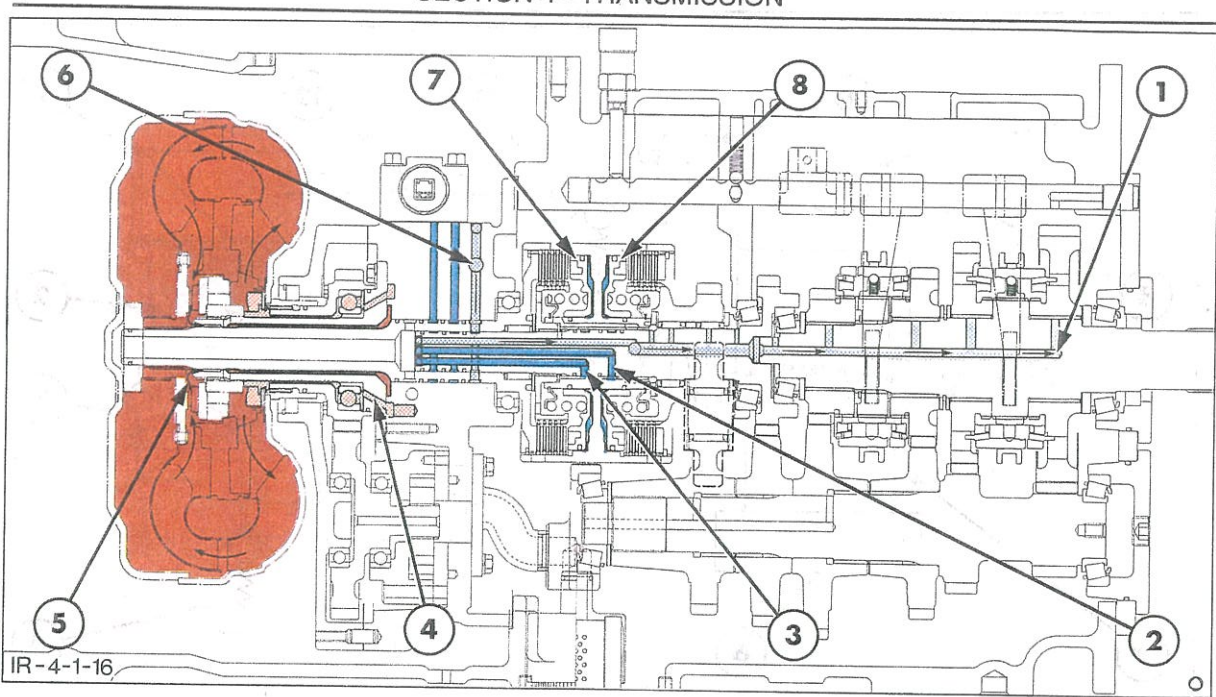

FIGURE 4-16

Transmission Lubrication Oil Flow

- |                            |                                |
|----------------------------|--------------------------------|
| 1 Lubrication gallery      | 5 Return from torque converter |
| 2 Reverse clutch gallery   | 6 Return from oil cooler       |
| 3 Forward clutch gallery   | 7 Forward clutch               |
| 4 Feed to torque converter | 8 Reverse clutch               |

Oil from the torque converter then flows back to the distributor between the stator support and the front input shaft. It is then picked up by the cooler tube on the left-hand side of the transmission case and directed to the cooler, Figure 4-17. The cooler is located in front of the engine coolant radiator with the backhoe/loader hydraulic oil cooler, Figure 4-19.

Oil from the cooler is returned to the transmission via a tube on the left-hand side of the tractor to the oil filter then over the transmission housing and through a tube on the right-hand side of the transmission case, Figure 4-18. The tube directs the oil via the distributor to the lubrication passages in the rear input shaft rear clutch hub and the output shaft for lubrication of bearings, Figure 4-16.

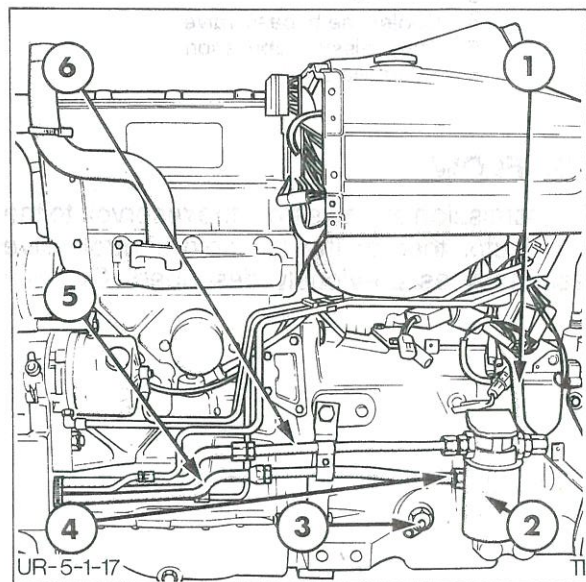

FIGURE 4-17

Transmission Cooling System

- |                      |                       |
|----------------------|-----------------------|
| 1 Filter return pipe | 4 Pressure test point |
| 2 Filter             | 5 Cooler inlet line   |
| 3 Temperature switch | 6 Cooler outlet line  |

## SECTION 4 - TRANSMISSION

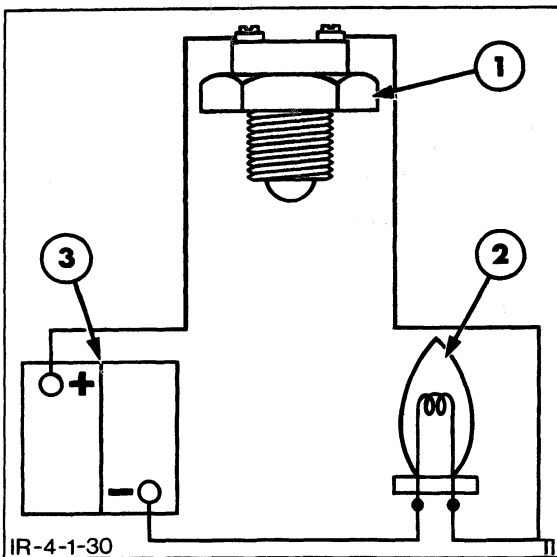

FIGURE 4-28

### Safety Start Switch Test

- 1 Switch
- 2 Bulb
- 3 Battery

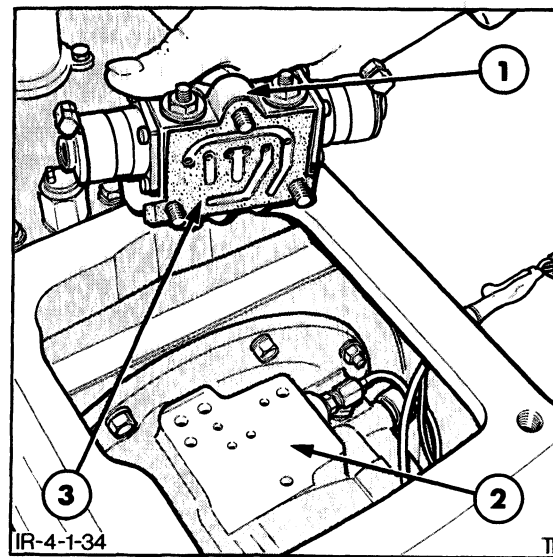

FIGURE 4-29

### Solenoid Control Valve Removal

- 1 Solenoid control valve assembly
- 2 Oil distributor
- 3 Gasket

## INSPECTION

1. Inspect the conical ends of the switch plungers for nicks or burrs. If nicks or burrs exist that cannot be removed by polishing, install a new plunger.
2. Check the safety start switches for operation by connecting the switch to a suitable bulb and battery as illustrated in Figure 4-28.
3. Depress and then release the operating button. The switch is operating correctly if the light comes on when the button is depressed and goes out when the button is released. If the switch is faulty, install a new switch.

## INSTALLATION

1. Install a new O ring seal onto the safety start switches, then install into the transmission top cover and tighten to 25 ft. lbs.
2. Install the steering console lower panel.

## SOLENOID CONTROL VALVE

### REMOVAL

1. Remove the fuel tank.
2. Remove the steering column assembly as described in Section 7 "Steering Systems."
3. Remove the solenoid control valve wiring harness retaining clips then withdraw the connectors from the control valve solenoids.
4. Remove the solenoid control valve retaining bolts and lift the solenoid control valve from the distributor housing, Figure 4-29.

**NOTE:** The solenoid valve is serviced as an assembly, therefore, the only check that is possible is to confirm the spool moves freely. Refer to "Component Overhaul" for solenoid control valve inspection.

## SECTION 4 - TRANSMISSION

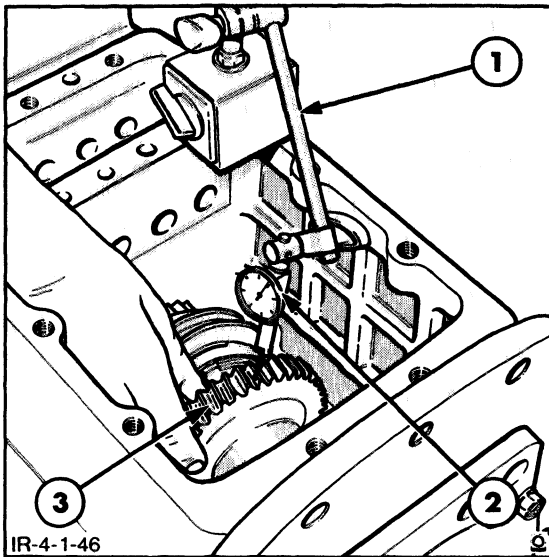

FIGURE 4-45

### Gear Backlash Check

- 1 Gear backlash bracketry
- 2 Dial indicator
- 3 Stylus

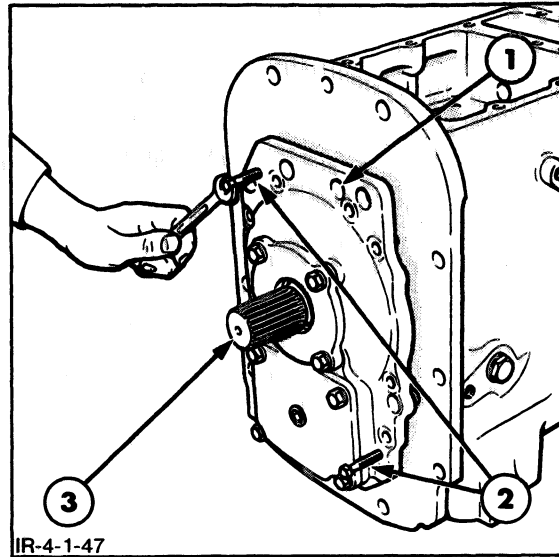

FIGURE 4-46

### Rear Cover Plate Removal

- 1 Rear cover
- 2 Jacking bolts
- 3 Output shaft

## REAR COVER PLATE

1. If transmission gear wear is suspected, then prior to removing the rear cover and output shaft bearing retainer, check the gear backlash. Position a dial indicator gauge on the transmission casing as shown in Figure 4-45, and measure the backlash on output shaft gears.
2. Prior to removing the rear cover and output shaft bearing retainer, tie the output shaft and countershaft together with a suitable length of cord.
3. Remove the rear cover retaining bolts, then screw two jacking bolts into the rear cover as shown in Figure 4-46. Tighten the two jacking bolts equally until the rear cover is free of the transmission case. Remove the two jacking bolts and remove the rear cover assembly.

**COMPONENT OVERHAUL****Torque Converter**

Transmission Hydraulic Pump and Oil Distributor Assembly

Control Valve

Front Input Shaft and Hydraulic Clutch

Reverse Idler Gear Assembly

Rear Input Shaft

Output Shaft and Gear Assembly

Countershaft and Gear Assembly

**TORQUE CONVERTER**

The torque converter, Figure 4-64, is a welded unit and cannot be disassembled. The only maintenance performed on the converter, other than the stall test, is cleaning and visual inspection. A commercial torque converter cleaner may be used to clean the converter. However, if a commercial cleaner is not available, the converter should be cleaned as outlined below.

1. Drain as much oil as possible from the hub of the converter by tilting the converter in all directions.
2. Fill the converter about half full, through the hub, with paraffin base solvent or any cleaning solvent specified for cleaning transmissions.
3. Plug the opening in the hub, then circulate the solvent inside the converter by shaking.
4. Remove the plug from the hub opening. Drain the solvent from the converter.
5. Repeat Steps 1 to 4, as required, until the solvent that is drained from the converter is clean.

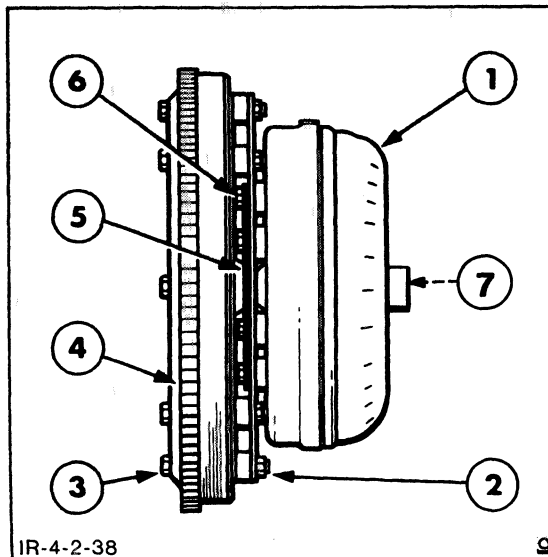
**FIGURE 4-64****Torque Converter and Drive Plate**

- 1 Torque converter assembly
- 2 Drive plate assembly
- 3 Flywheel to drive plate bolts
- 4 Flywheel
- 5 Reinforcing plate
- 6 Drive plate to torque converter bolts
- 7 Splines

**INSPECTION**

Inspect the splines, Figure 4-64, on the converter hub for wear or damage and the weld joints for cracks. If the hub is worn or damaged and/or the weld joints cracked, a new converter should be installed. A new drive plate should also be installed if it is warped.

## SECTION 4 - TRANSMISSION

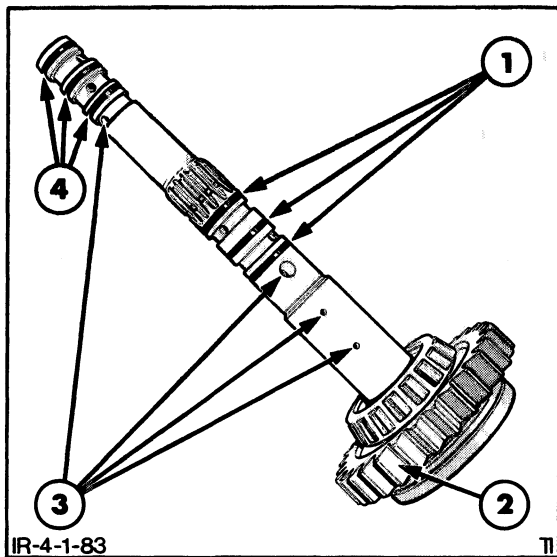

FIGURE 4-81

### Rear Input Shaft Assembly

- 1 Rear sealing rings
- 2 Gear shaft assembly
- 3 Lubrication gallery oil holes
- 4 Front sealing rings

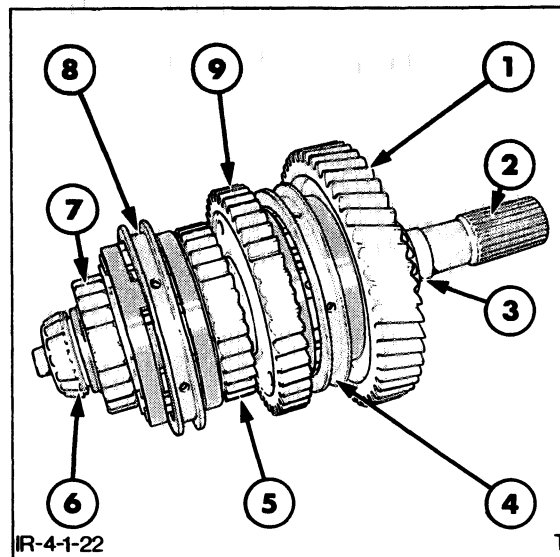

FIGURE 4-82

### Output Shaft Assembly

- 1 1st Gear
- 2 Output shaft
- 3 Rear bearing
- 4 Synchromesh coupler
- 5 3rd Gear
- 6 Front bearing
- 7 4th Gear
- 8 Synchromesh coupler
- 9 2nd Gear

## REAR INPUT SHAFT

### INSPECTION

1. Thoroughly clean the rear input shaft with a suitable solvent and allow to dry. Use compressed air to clean out the oil passages, Figure 4-81. Do not spin the bearing with compressed air.
2. Check the bearing for smooth rotation. Normally the rear input shaft bearing need not be removed, however, if the bearing is worn or damaged it can be removed by clamping the shaft between two blocks of wood and driving the bearing from the shaft with a punch and hammer. If the bearing is removed a new one must be installed as the cage will be damaged during removal.

3. Inspect the rear input shaft sealing rings for nicks, cracks or scratches. Any seals which are suspect should be replaced on assembly. Ensure all oil passages are clean.
4. Inspect the gear teeth for burrs. Remove burrs with fine emery paper or a fine pumice stone. If the gear is chipped or cracked, a new one should be installed.

## OUTPUT SHAFT AND GEAR ASSEMBLY

### DISASSEMBLY

1. Engage the 3rd/4th gear synchronizer assembly to the 3rd gear as shown in Figure 4-83.

SECTION 4 - TRANSMISSION

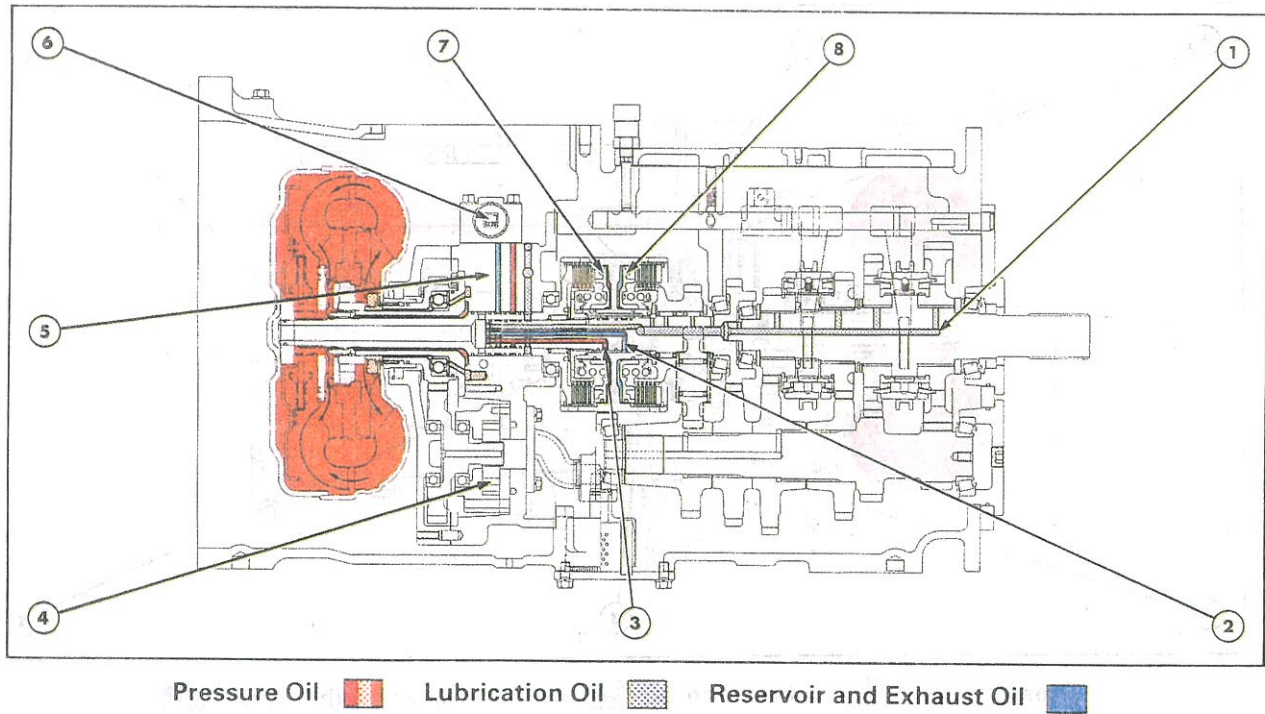

Pressure Oil  Lubrication Oil  Reservoir and Exhaust Oil

FIGURE 4-92

4 x 4 Power Reversing

Forward Clutch And Lubrication Oil Flows

- |   |   |
|---|---|
| <ul style="list-style-type: none"> <li>1 Output shaft lubrication gallery</li> <li>2 Reverse clutch feed gallery</li> <li>3 Forward clutch feed gallery</li> <li>4 Transmission pump</li> </ul> | <ul style="list-style-type: none"> <li>5 Oil Distributor</li> <li>6 Solenoid control valve</li> <li>7 Forward clutch piston</li> <li>8 Reverse clutch piston</li> </ul> |
|---|---|

SECTION 4 - TRANSMISSION

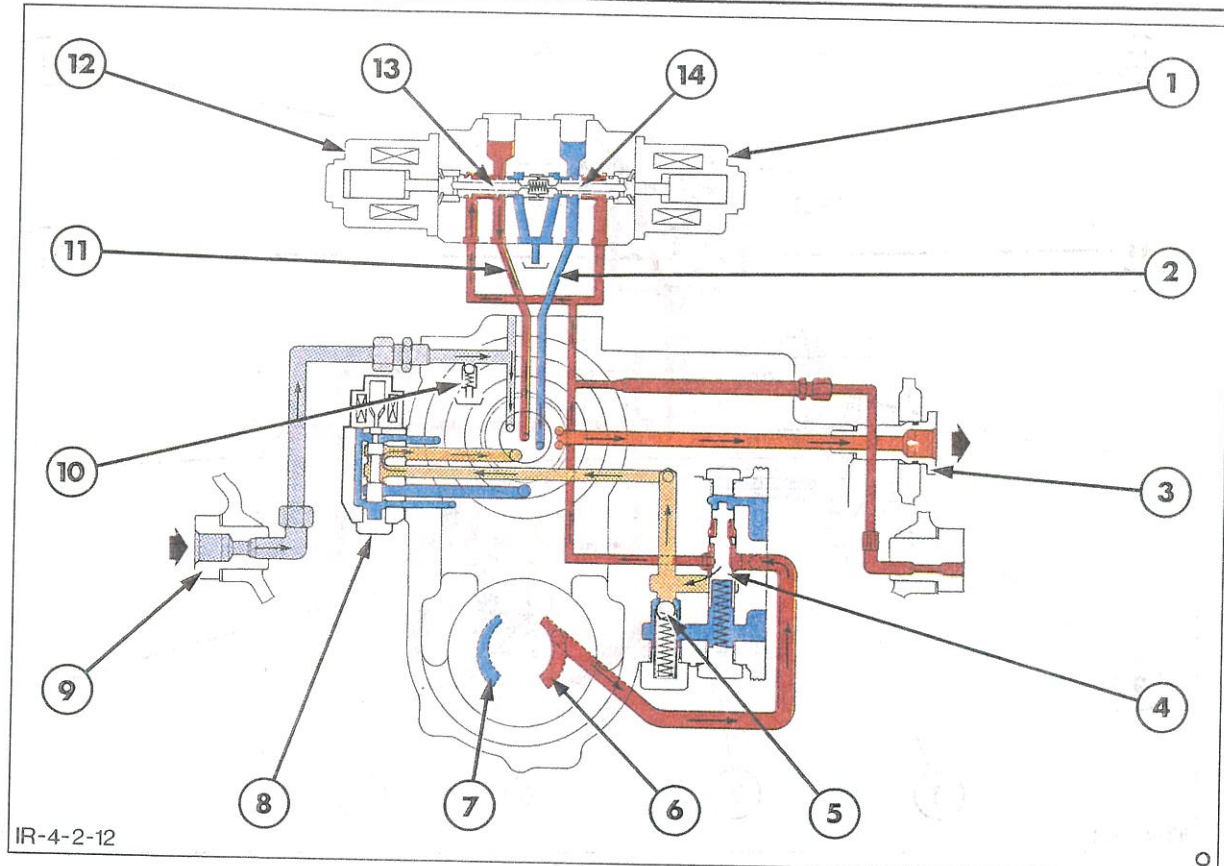

IR-4-2-12

- Pump Pressure Oil
- Lubrication Oil
- Torque Converter Pressure Oil
- Reservoir and Exhaust Oil
- Torque Converter Return Oil

FIGURE 4-105

Oil Flow - In Reverse

- 1 Forward solenoid
- 2 Forward clutch oil gallery
- 3 Feed port to oil cooler
- 4 Regulating valve
- 5 Bypass valve
- 6 Oil pump outlet
- 7 Oil pump inlet
- 8 Lock-up valve
- 9 Return port from oil cooler
- 10 Cooler bypass valve
- 11 Reverse clutch oil gallery
- 12 Reverse solenoid
- 13 Reverse spool
- 14 Forward spool

Selecting reverse travel sends a signal from the modulating unit to the reverse solenoid of the control valve. The operation of the reverse section of the control valve is the same as the forward section, however, now the pressure regulated oil is directed to the reverse clutch pack, Figure 4-105, and power is delivered to the transmission gearbox via the rear input gear (reverse clutch hub).

De-energized, the forward solenoid moves back to the neutral position under spring pressure and the spool aligns the forward clutch pack oil gallery with the exhaust port.

SECTION 4 - TRANSMISSION

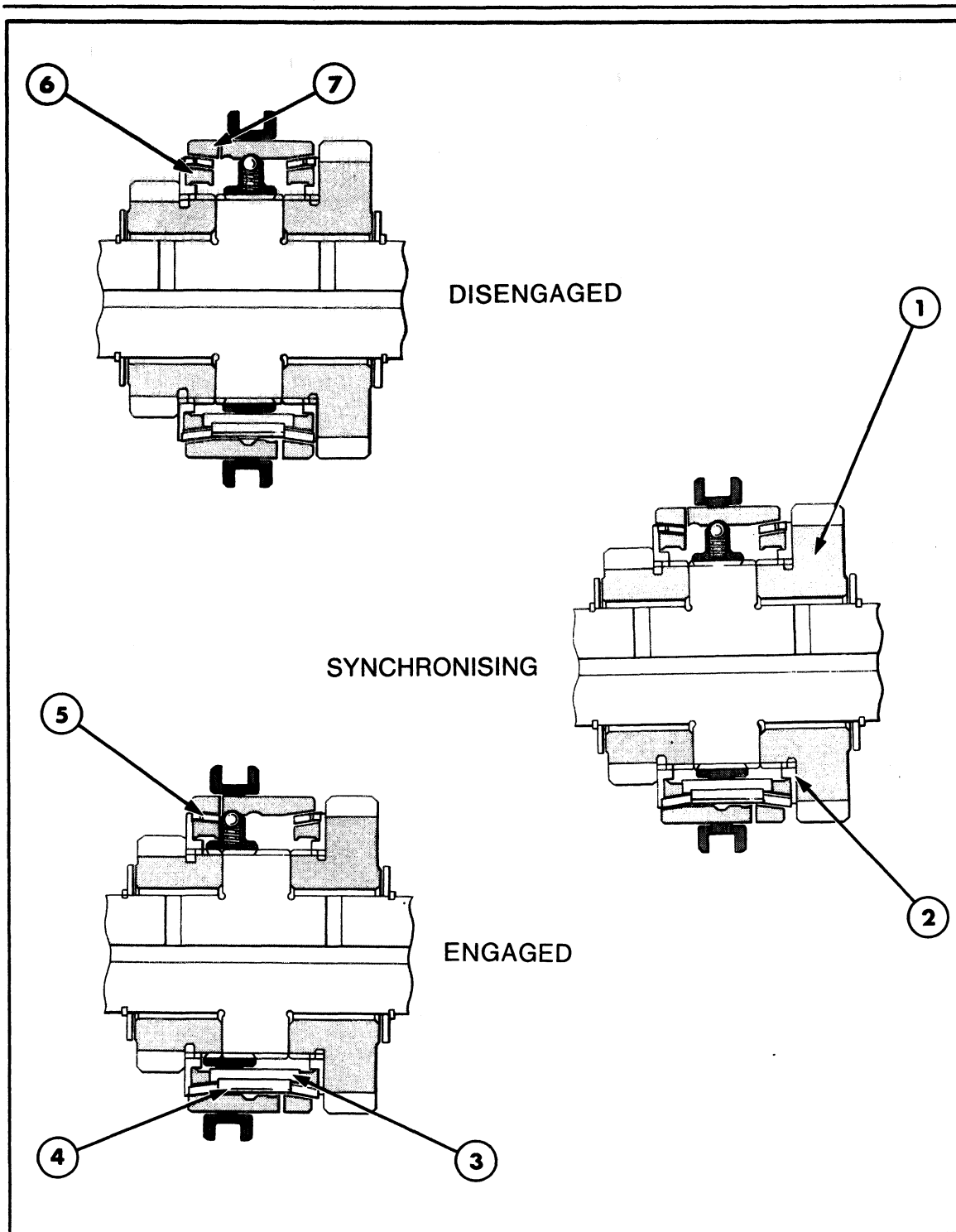

FIGURE 4-118

Synchronizer Operation

- |                                  |                     |
|----------------------------------|---------------------|
| 1 Gear                           | 5 Synchronizer ring |
| 2 Synchronizer                   | 6 Inner cone        |
| 3 Inner cone pins (long)         | 7 Outer cone        |
| 4 Synchronizer ring pins (short) |                     |

## SECTION 4 - TRANSMISSION

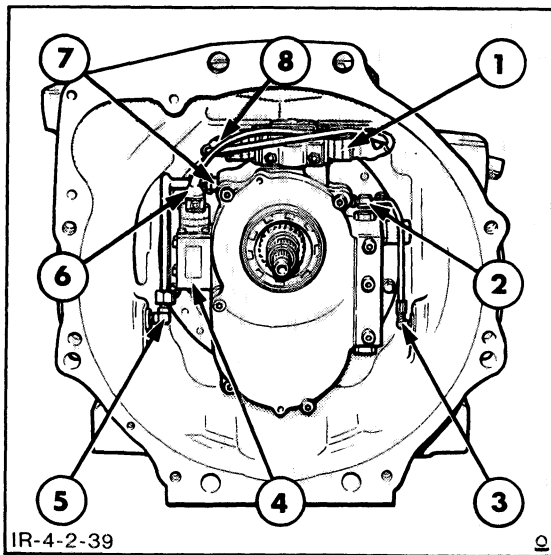

FIGURE 4-130

### Front View Of Transmission Case

- 1 Solenoid connection
- 2 Test port line
- 3 Test port line
- 4 Lock-up valve
- 5 Return line
- 6 Solenoid connection
- 7 Return line
- 8 Solenoid connection

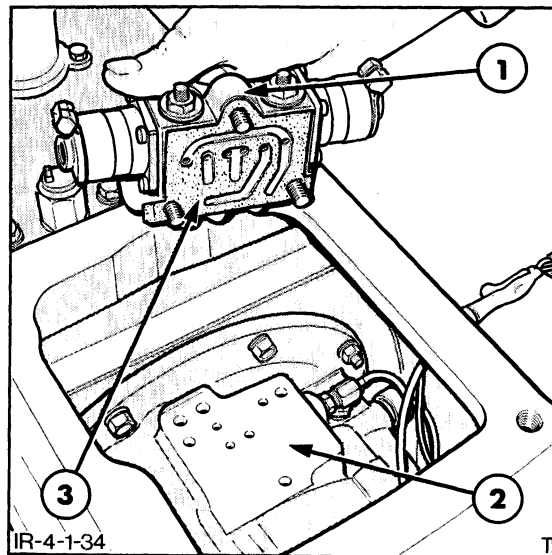

FIGURE 4-131

### Solenoid Control Valve Removal

- 1 Solenoid control valve assembly
- 2 Oil distributor
- 3 Gasket

## TRANSMISSION HYDRAULIC PUMP AND OIL DISTRIBUTOR HOUSING

1. Disconnect the oil cooler return pipe and elbow at the transmission case, Figure 4-130. Disconnect the return pipe at the oil distributor housing and remove the pipe from the transmission case.
2. Disconnect the pressure test port feed pipe and elbow at the transmission case. Disconnect the feed pipe at the oil distributor housing and remove the pipe from the transmission case, Figure 4-130.
3. Disconnect the wiring harness from the lock-up valve and the solenoid control valve and remove from the transmission case; note the color and the position of the three connectors.
4. Remove the solenoid control valve securing bolts and remove the solenoid control valve from the distributor housing, Figure 4-131.

Refer to "Component Overhaul" for disassembly of the solenoid control valve.

**INSTALLATION****COUNTERSHAFT PRE-LOAD CHECK**

1. If any of the following parts have been replaced, then it will be necessary to check the countershaft pre-load.

Taper roller bearings

Countershaft

Thrust washers

The pre-load is checked with all components removed from the transmission case except the countershaft. To determine the shims required to give the specified pre-load of 12-16 lbs. (53-71 N) rolling torque.

2. Assemble the countershaft and gear assembly as described in "Component Overhaul".
3. Install the assembled countershaft and gear assembly through the rear of the transmission case and position in such a way that the rear bearing just protrudes from the rear of the case.
4. Ensure the countershaft bearing cap attaching bolts are tightened to 35-41 ft. lbs.
5. Insert a suitable rod through the bearing cap hole and into the countershaft assembly, Figure 4-151.
6. Position the rear cover to the transmission case while lifting the countershaft with the rod.

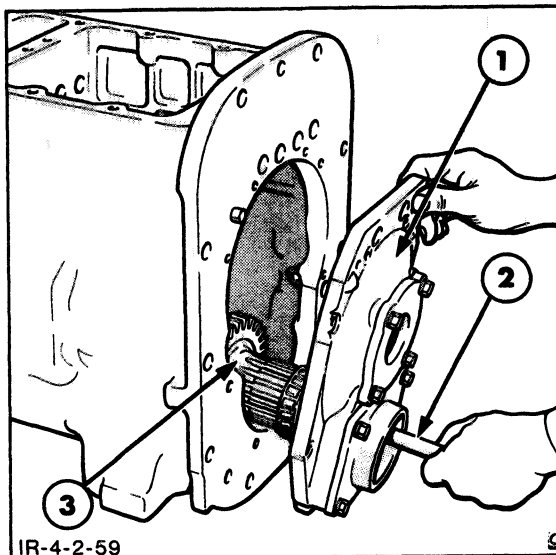

FIGURE 4-151

Countershaft Installation

- 1 Rear cover
  - 2 Rod
  - 3 Point to wrap cord
7. Secure the rear cover to the transmission case and tighten the retaining bolts to 35-41 ft. lbs.
  8. Rotate the countershaft assembly until the bearings run smoothly.

## SECTION 4 - TRANSMISSION

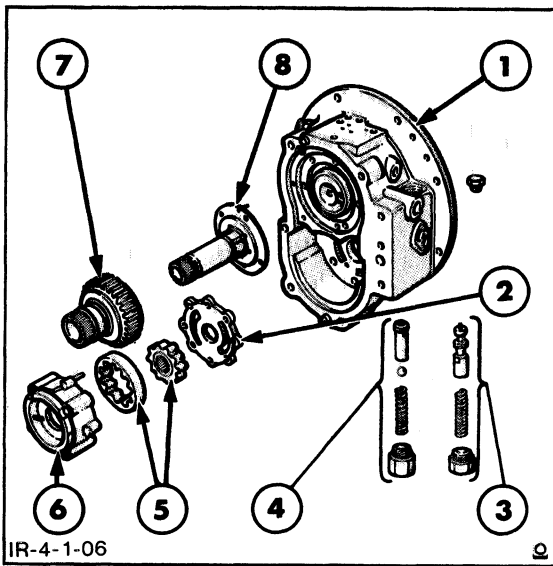

FIGURE 4-171

### Oil Distributor Housing Components

- |                       |                   |
|-----------------------|-------------------|
| 1 Distributor housing | 5 Pump rotors     |
| 2 Pump end plate      | 6 Pump body       |
| 3 Regulating valve    | 7 Pump drive gear |
| 4 By-pass valve       | 8 Stator support  |

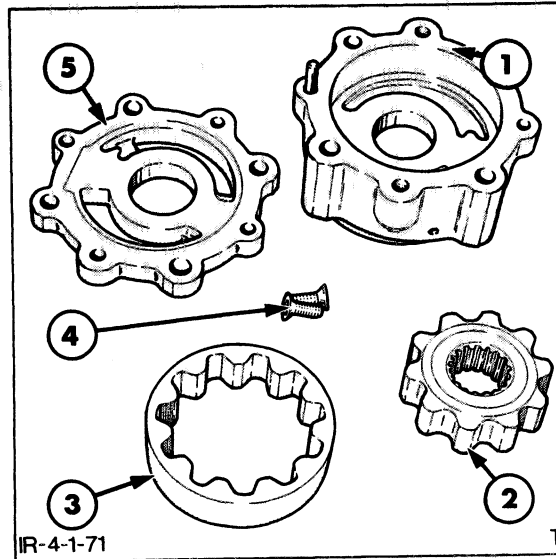

FIGURE 4-172

### Transmission Pump Components

- |               |                    |
|---------------|--------------------|
| 1 Pump body   | 2 Inner rotor      |
| 3 Outer rotor | 4 End plate screws |
| 5 End plate   |                    |

4. Remove the hydraulic pump retaining bolts and lift the pump assembly from the distributor housing, Figure 4-171.
5. Remove the by-pass valve plug and extract the shim, spring ball and valve, Figure 4-171.
6. Remove the regulating valve plug and extract the spring, shim and spool.
7. Remove the O ring seals from the valve plugs and discard. Install new O rings on assembly.

### INSPECTION

1. Thoroughly clean all the transmission hydraulic pump and oil distributor components with a suitable solvent and allow to dry. Use compressed air to clean the oil passages in the distributor housing.
2. Inspect the hydraulic pump driven gear and the bearings on either side of the gear for wear or damage.

3. Inspect the front cover thrust washer for wear or scoring. If damaged, remove by prying the washer from the cover, do not remove if undamaged.
4. Inspect the front cover torque converter oil seal for damage. Do not remove the oil seal unless the seal is damaged. If damaged, remove the snap ring and drive the seal from the cover with a suitable punch and hammer.
5. Inspect the stator support gear and bearing for wear or damage. Check the seal rings for wear, nicks or other damage.
6. Disassemble the hydraulic pump, if not already disassembled, and inspect the inner and outer rotors for scratching and scoring or excessive wear.

## SECTION 4 - TRANSMISSION

3. Inspect the output shaft gears for cracks, burrs, or chipped teeth. Remove burrs with fine emery cloth or a fine pumice stone. If the gears are chipped or cracked, new gears should be installed.
4. Place the gears on the output shaft and check for excessive play between the gear bushings and shaft. If the play feels excessive, new gears should be installed, as the bushings are not serviced separately.
5. Inspect the synchronizer assembly for scoring, cracks or excessive wear. Check the pins, springs and balls for wear or cracks. If any components of the synchronizer are damaged, the complete assembly will require replacement as the components are not serviced separately.
2. Install the L/H gear synchronizer assembly over the front end of the shaft and locate onto the splines.
3. Install the thrust washer and needle roller bearing onto the shaft, then install the "H" range and 2nd driven gear cluster over the bearing.
4. Install the second needle roller bearing onto the shaft and insert into the gear cluster.
5. Install the 4th gear onto the gear cluster and retain with the appropriate snap ring, then install the coupler onto the shaft and retain in position with the snap ring.
6. Install the thrust washer and front bearing onto the shaft, then drive or press the bearing into place using a hammer or press, and a sleeve of appropriate diameter and convenient length.

### ASSEMBLY

Refer to Figure 4-187.

1. Install the "L" range gear, thrust washer and rear bearing onto the shaft, then drive or press the bearing into place using a hammer or press, and a sleeve of the appropriate diameter and length.
7. Install the 3rd/4th gear synchronizer assembly onto the coupler.
8. Install the output shaft and gear assembly as previously covered in "Complete Overhaul."

SECTION 4 - TRANSMISSION

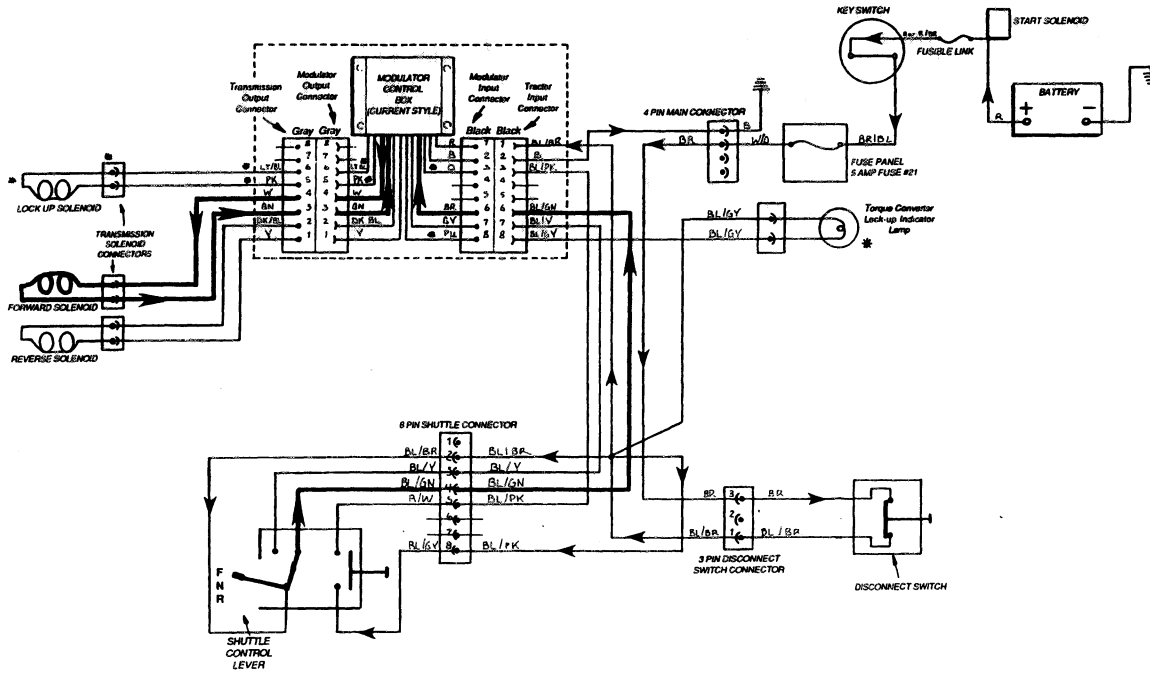

\* = Only on Units with 8X8 Transmission

This schematic shows units without the fused wire harness. On units equipped with the fused wire harness refer to the fused wire harness schematic which will show the wiring inside the dotted area.

FIGURE 4-198

**FORWARD CIRCUIT**

Refer to Figure 4-198.

Placing the control lever in the forward position closes the forward switch so that power flows through the switch, back through the connector, through the modulator control box black input connector, to the modulator control box.

The input signal is received by the control box at battery voltage. The control box processes the signal and sends a modulated output signal through the control box gray output connector to the forward solenoid.

The forward solenoid receives power, but will not operate until the circuit is grounded. This is an important point to remember when troubleshooting.

Power passes through the solenoid, back through the control box gray connector, and through the control box to ground.

When the ground circuit is complete, the output signal from the control box increases from 0 volts to battery voltage in approximately 4 seconds, and the transmission forward clutch pack is gradually engaged.

SECTION 4 - TRANSMISSION

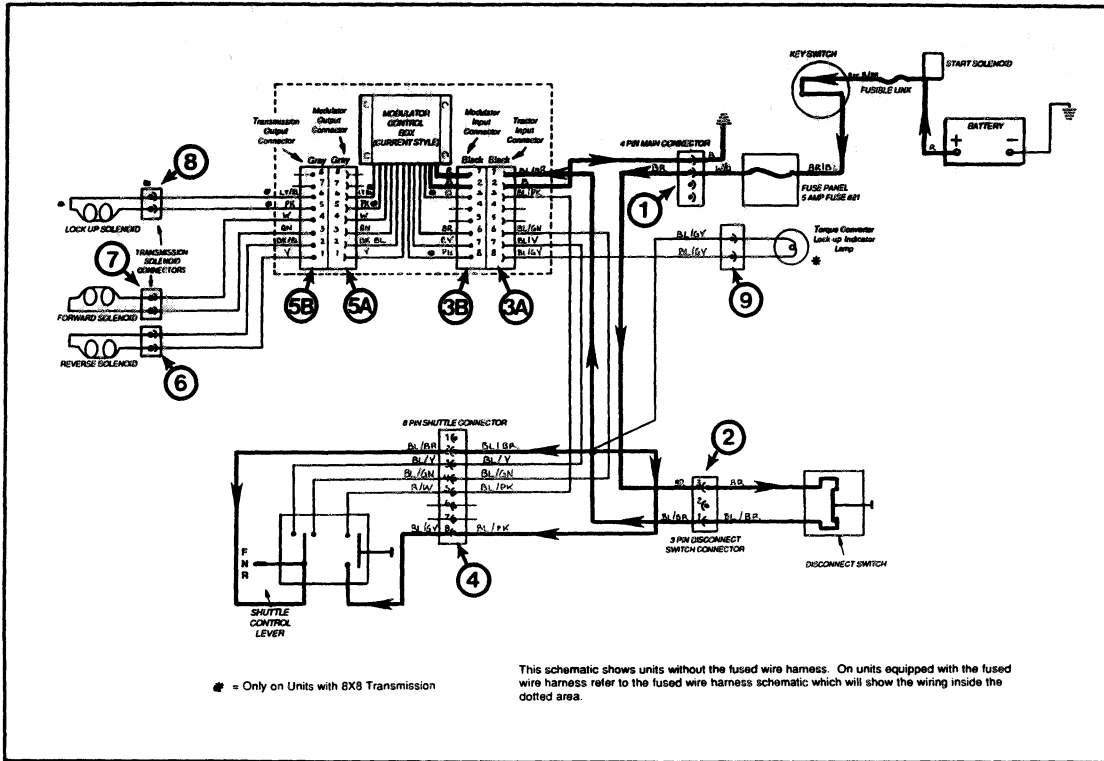

Straddle Mount Power-Up Circuit

**FLOWCHART C  
OUTPUT CIRCUIT TEST**

**Symptom: Transmission Won't Operate in Forward or Reverse Mode or Operates in One Direction Only**

NOTE: If test voltage is below specification, check battery voltage before proceeding.

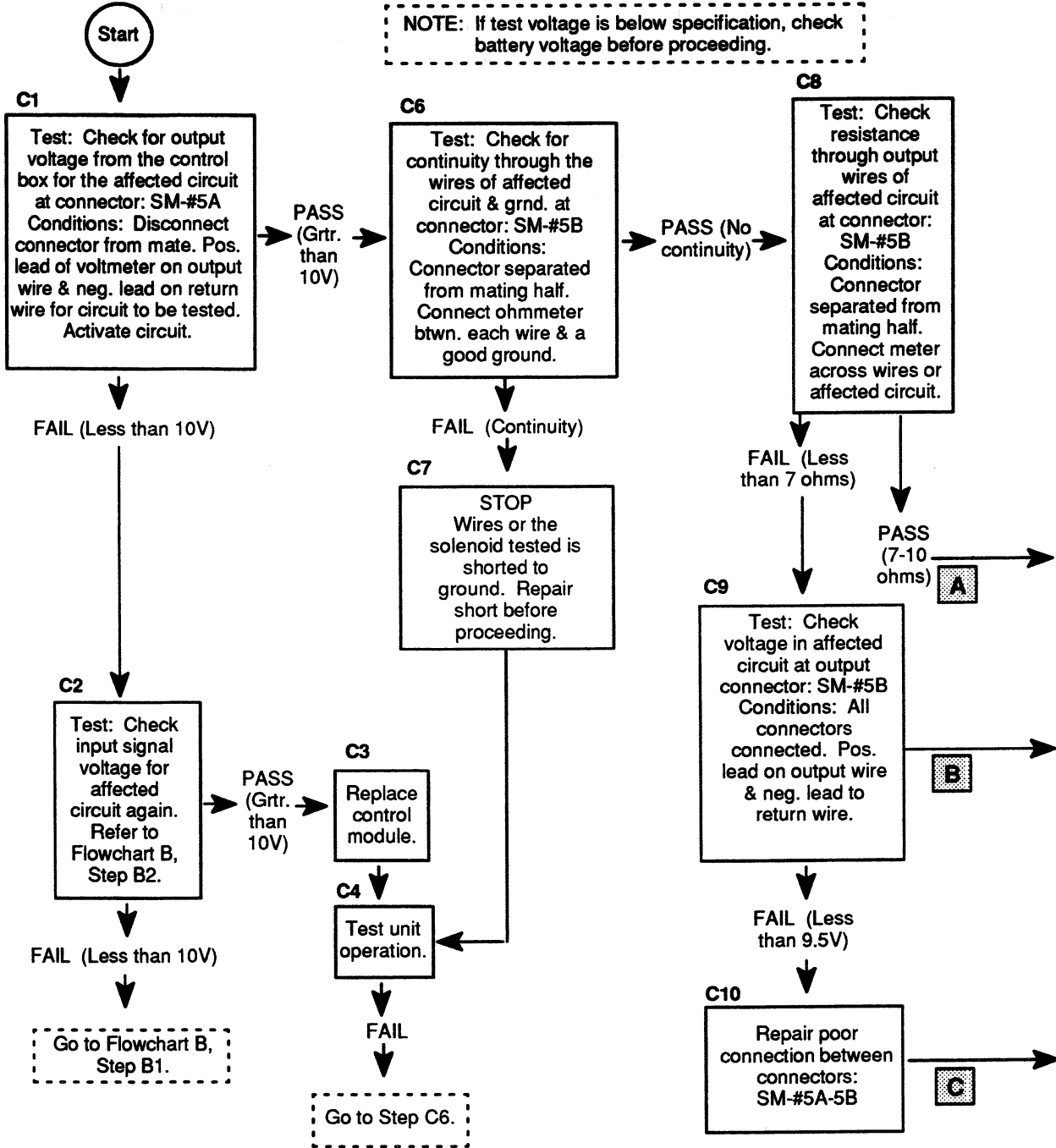

## SECTION 4 - TRANSMISSION

3. Lock the brakes and shift into fourth gear, increase engine speed to approximately 900 RPM, then shift the power reversing lever to the forward position. This will position the control valve so as to direct high pressure oil to the front clutch.
4. Ensure the brakes are firmly locked so the unit will not move, gradually depress the foot accelerator and note the maximum engine speed obtained. Move the power reversing lever to the neutral position. The stall speed should be:

260C, 545D	1900-2000 RPM
250C, 345D	1700-1800 RPM
445D	1800-1900 RPM

*IMPORTANT: To prevent the transmission from overheating, do not allow the engine to operate at wide open throttle for more than fifteen seconds.*
5. Allow the transmission oil to cool to 85°-95° F (29°-35° C). Check the rear hydraulic clutch by repeating Steps 3 and 4, but with the power reversing lever in the rearward position. Again, cool the transmission oil by allowing the engine to run at approximately 1000 RPM for one minute.
6. The engine speed noted in Step 4 (stall speed) for both the front and rear clutch assemblies should be within 150 RPM of each other. If the stall speed is not within these limits, refer to the diagnosis guide for possible causes.
7. With the gearshift lever and power reversing lever in neutral, set the engine speed at 600-800 RPM, then shift into any gear ratio. If the gears clash, either the front or rear hydraulic clutch assembly is transmitting power, even though the power reversing lever is in neutral.

**NOTE: If the unit creeps forward and the gears clash, the front clutch is at fault. The rear clutch is at fault if the unit creeps backward. If the unit does not creep and the gears still clash, use the stabilizers to raise the rear wheels off the ground, move the power reversing lever to neutral and shift into first gear. Check the rear wheels for rotational direction - if the wheel rotate rearward, then the rear clutch is at fault.**

## SECTION 4 - TRANSMISSION

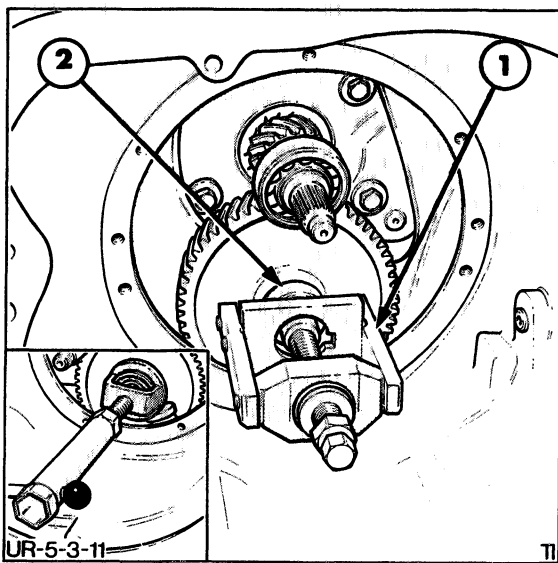

**FIGURE 4-216**

### Removing PTO Countershaft Front Bearing

1. Tool nos. FNH02134 and FNH01238
2. PTO countershaft front bearing

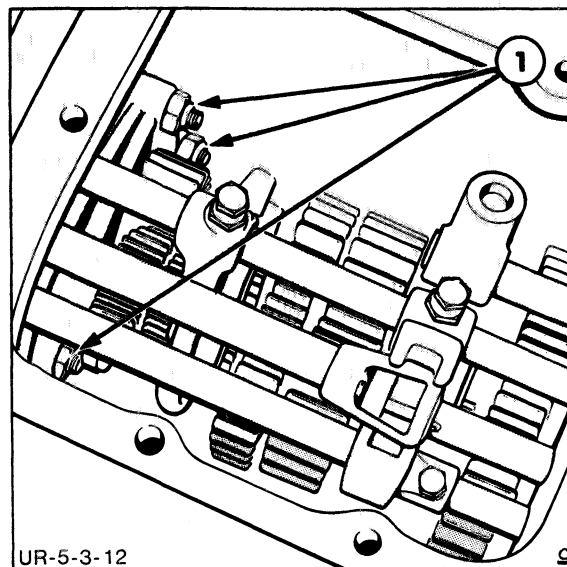

**FIGURE 4-217**

### Input Shaft Bearing Retainer Plate Attaching Nuts

1. Retainer plate attaching nuts

7. Remove the PTO countershaft from bearing, Figure 4-216, using Tool Nos. FNH02134 and FNH01238.

8. Remove the three attaching nuts, Figure 4-217, from the input shaft bearing retainer plate bolts, Figure 4-218, and remove the bolts. remove the self-locking bolt and pull the plate and input shaft as an assembly from the transmission.

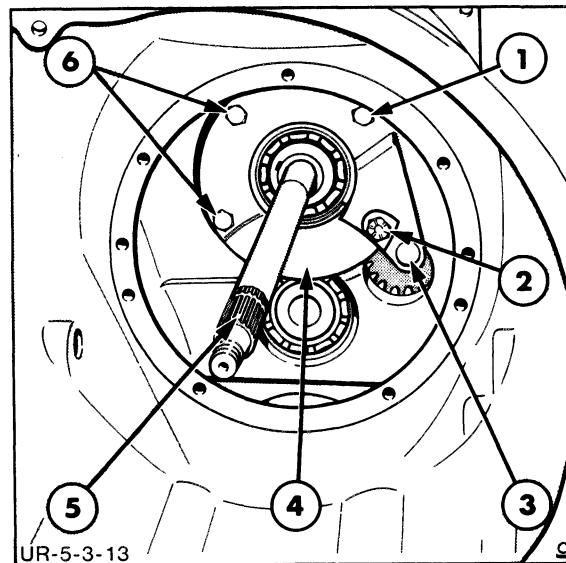

**FIGURE 4-218**

### Input Shaft Bearing Retainer Plate

1. 3-3/4" (95.2 mm) bolt
2. Self locking bolt
3. Front reverse idler shaft
4. Input shaft retainer plate
5. Input shaft
6. 3-1/4" (82.5 mm) bolts

## SECTION 4 - TRANSMISSION

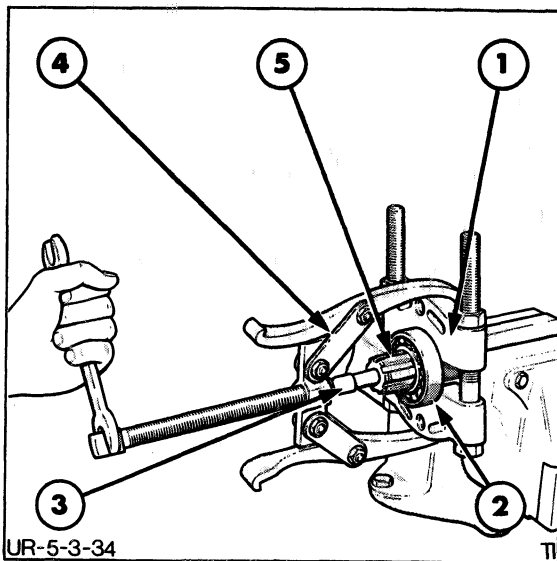

FIGURE 4-239

### PTO Countershaft Rear Bearing - Removal

1. Tool No. FNH09190
2. Rear Bearing
3. Tool No. FNH09212-6
4. Tool No. FNH09198
5. PTO countershaft

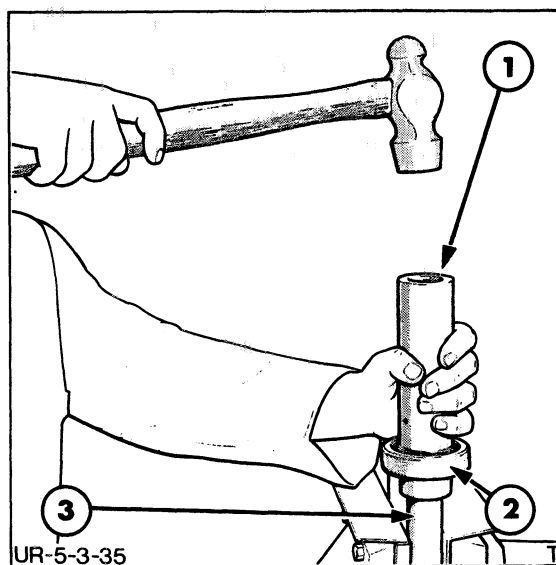

FIGURE 4-240

### PTO Countershaft Rear Bearing - Installation

1. Sleeve (1-17/16" I.D. x 1-3/4" O.D.)
2. Rear bearing
3. PTO countershaft

### Rear Support Plate

1. Inspect the PTO countershaft rear bearing for wear or damage. If necessary, remove the bearing, as shown in Figure 4-239.

**NOTE:** Use Tool No. FNH09212-2 in place of Tool No. FNH09212-6 when removing the bearing on transmissions with independent PTO.

2. Install a new bearing on the shaft and drive it into place with a sleeve of the appropriate diameter and convenient length as shown in Figure 4-240 .
3. Inspect the PTO countershaft oil seal in the rear support plate for wear or damage. If necessary, drive the seal from the front of the support using a suitable punch.
4. Apply a light film of oil on a new seal and install the seal using Tool No. FNH09211-13 and a soft-faced mallet as shown in Figure 4-241.

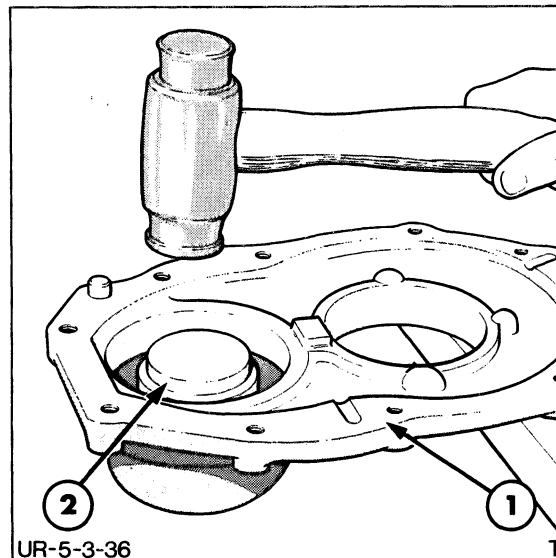

FIGURE 4-241

### PTO Countershaft Oil Seal - Installation

1. Rear support plate
2. Tool No. FNH09211-13

## SECTION 4 - TRANSMISSION

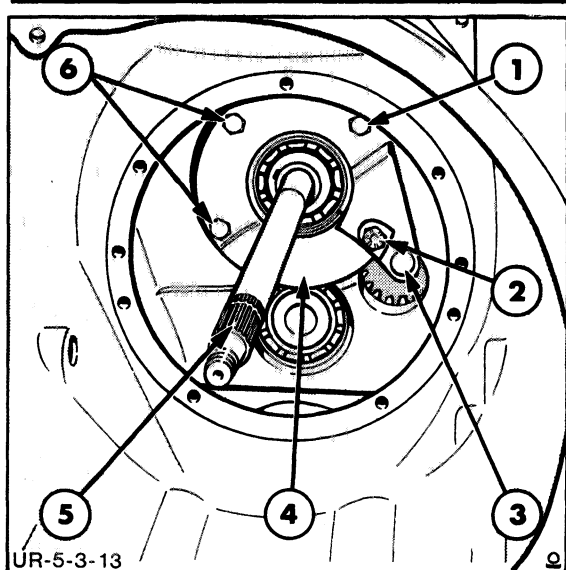

FIGURE 4-260

### Input Shaft Bearing Retainer Plate

1. 3-3/4" (95.2 mm) bolt
2. Self locking bolt
3. Front reverse idler shaft
4. Input shaft retainer plate
5. Input shaft
6. 3-1/4" (82.5 mm) bolts

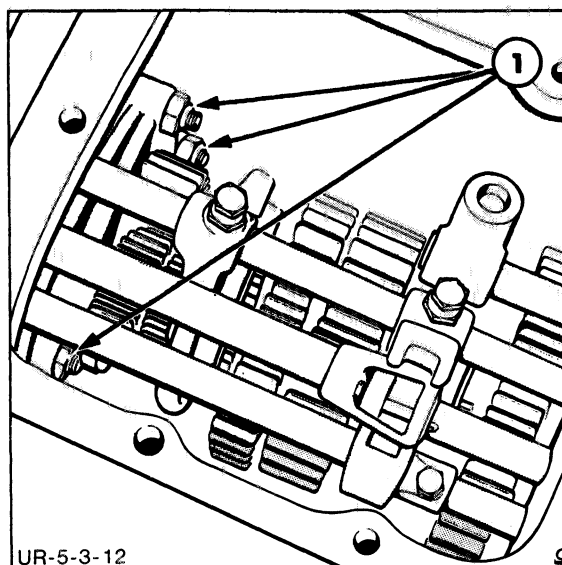

FIGURE 4-261

### Input Shaft Bearing Retainer Plate Attaching Nuts

1. Retainer plate attaching nuts

5. Install the arm assembly in the shift fork in the bottom of the case.
6. Install the 3rd-6th rail, Figure 4-258, in the bore nearest the left hand side of the case. Install the arm assembly on the rail, keeping the arm engaged in the shift fork. Install the retaining bolt and locknut and tighten them to 20-25 ft. lbs. (27-34 N·m). Install the detent ball, spring, and plunger for each rail.

**NOTE:** Make sure all interlock plungers are positioned correctly, Figure 4-259.

### Input Shaft Bearing Retainer Plate and Input Shaft

1. Place the input shaft bearing retainer plate, Figure 4-260, in the transmission and tap it rearward so the front reverse idler shaft enters the hole in the plate as shown.

**IMPORTANT:** Be sure the flat spot on the front reverse idler shaft is indexed to match the machined flat on the rear of the retainer plate.

2. Secure the retainer plate in the transmission by installing the bolts, Figure 4-260. Tighten the bolts to 40-50 ft. lbs. (54-68 N·m), then install the three attaching nuts, Figure 4-261, and tighten them to 18-25 ft. lbs. (24-34 N·m).

SECTION 4 - TRANSMISSION

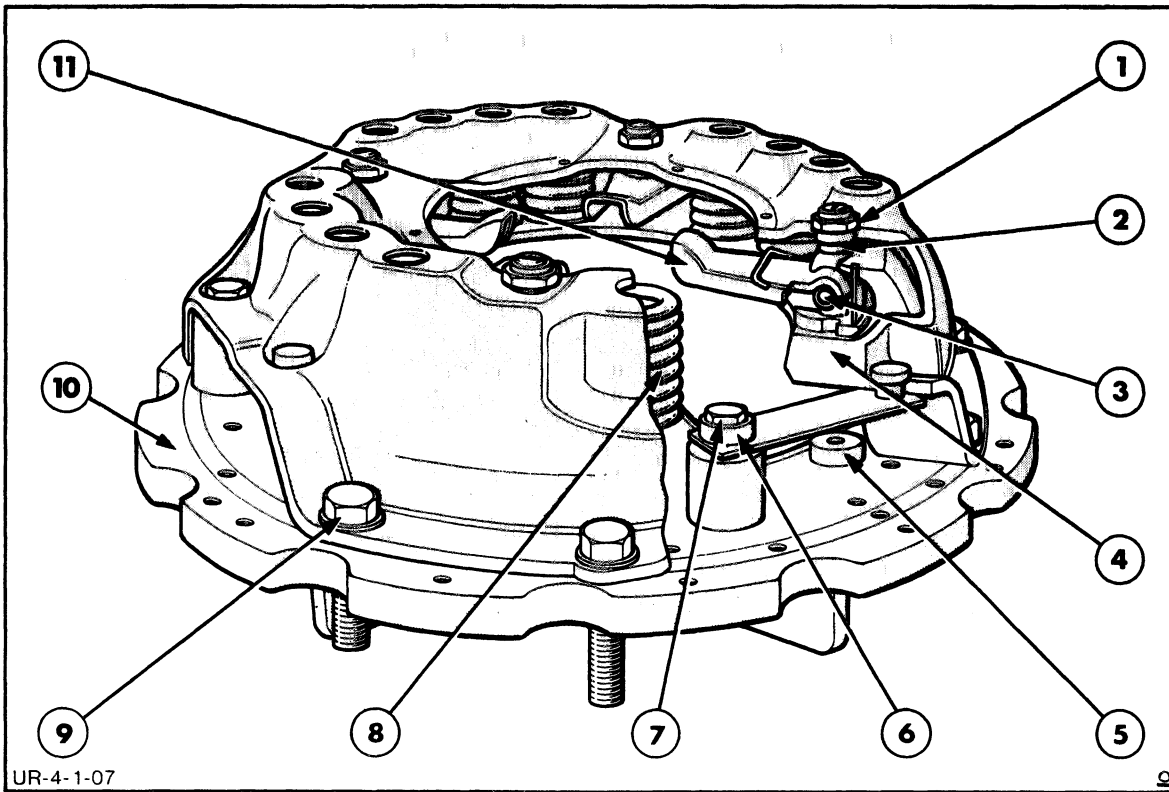

FIGURE 4-274

Clutch Mounted on Base Plate of Tool No. FT 7110

- |                                     |                                     |
|-------------------------------------|-------------------------------------|
| 1 Eyebolt nut                       | 7 Drive strap bolt                  |
| 2 Eyebolt                           | 8 Pressure spring                   |
| 3 Pivot pin                         | 9 Bolt - tool no. FT 7710/25        |
| 4 Pressure plate                    | 10 Base plate - tool no. FT 7110/15 |
| 5 Disc spacer - tool no. STM 6023/3 | 11 Release lever                    |
| 6 Ferrule                           |                                     |

2. Clean the pressure plate and cover assembly thoroughly, then locate the assembly centrally on the base plate, Figure 4-274, with the four clutch disc spacers, STM 6023/3, between the pressure plate and the base of the tool.
3. Secure the assembly to the base plate with the eight special tool bolts, FT7110/25, Figure 4-274. Tighten the bolts evenly and diagonally across the clutch.
4. Pry the locking ferrules clear of the drive strap bolt heads and remove the bolts using a socket through the holes in the cover.
5. Pry the staked portion of the release lever eyebolt nuts from the slots in each eyebolt and remove the nuts.

CLICK HERE TO **DOWNLOAD** THE COMPLETE MANUAL

- Thank you very much for reading the preview of the manual.
- You can download the complete manual from: [www.heydownloads.com](http://www.heydownloads.com) by clicking the link below



- Please note: If there is no response to CLICKING the link, please download this PDF first and then click on it.

CLICK HERE TO **DOWNLOAD** THE COMPLETE MANUAL

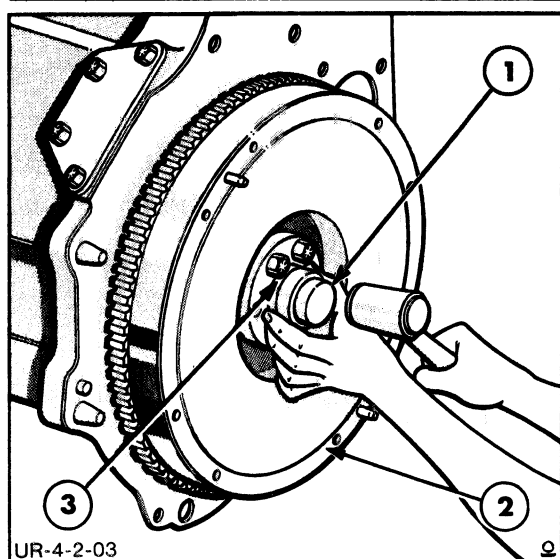

### INSTALLATION

1. Use step plate adaptor, Tool No. 818 or FNH09514, to install the bearing, Figure 4-287.
2. Reinstall the pilot bearing retainer and flywheel-to-crankshaft bolts and tighten to 100-110 ft. lbs.
3. Replace the clutch, see "Clutch Removal and Installation."

FIGURE 4-287

#### Installing the Pilot Bearing

- 1 Step plate adaptor, tool no. 818 or FNH09514
- 2 Flywheel
- 3 Pilot bearing

SECTION 4 - TRANSMISSION

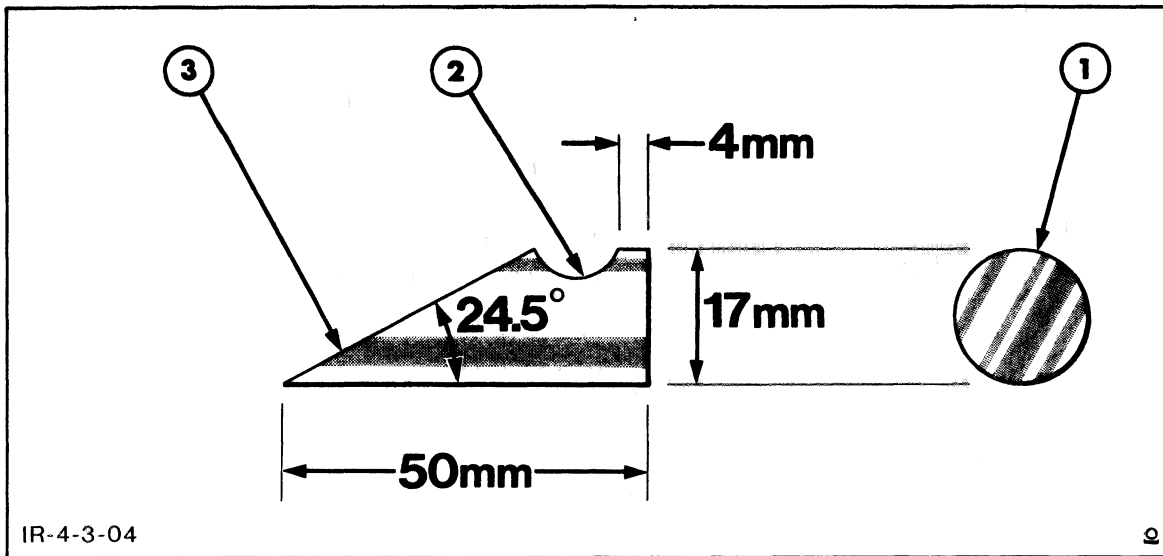

FIGURE 4-290

Lower Shift Rail Detent Retainer

- 1 17 mm bar stock
- 2 Grind groove to accept detent ball
- 3 Grind ramp to give 24.5° angle (approx)

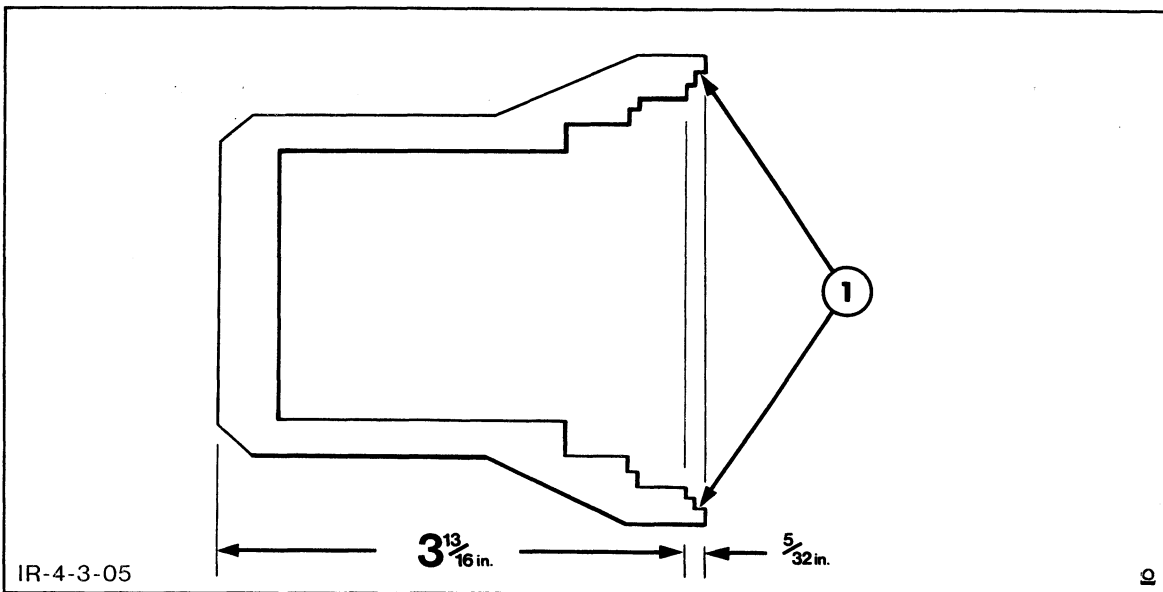

FIGURE 4-291

Spring Compressor FT4101 Modification

- 1 Remove stock from circumference of tool to give dimensions shown

## SECTION 5 - REAR AXLE AND BRAKES

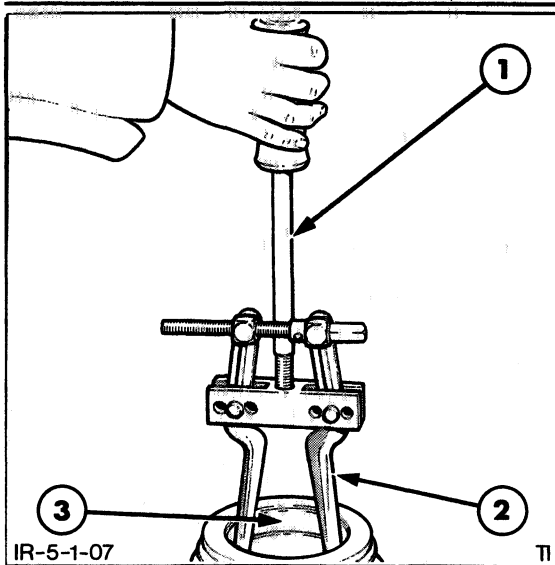

FIGURE 5-7

### Removing Outer Bearing Track from Axle Housing

- 1 Tool no. 943S or FNH09567
- 2 Tool no. 943 or FNH09507
- 3 Bearing track

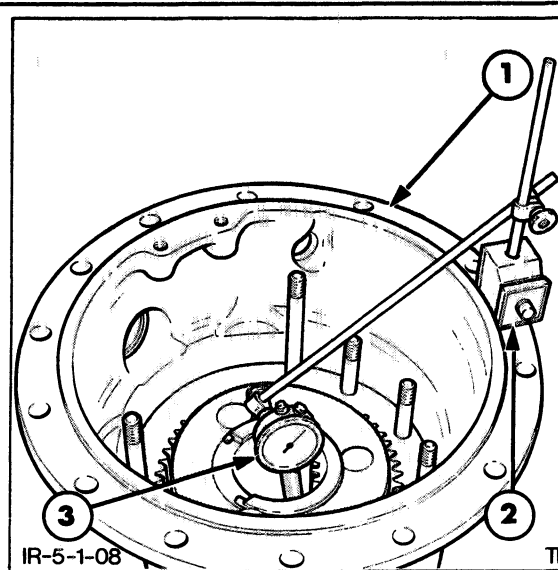

FIGURE 5-8

### Checking Axle Shaft Bearing Pre-Load

- 1 Axle housing
- 2 Magnetic base
- 3 Dial indicator

3. If necessary, remove the axle shaft outer bearing cup from the housing using Tool Nos. 943 or FNH09507 and 943S or FNH09567, Figure 5-7.

## REASSEMBLY

1. Position a new oil seal and retainer assembly on the axle shaft and place a new oil seal retainer gasket in the seal retainer. Use a 2.68" (68.2 mm) inside diameter and 3.12" (79.4 mm) outside diameter sleeve of a suitable length to install the new outer bearing assembly onto the axle shaft. Apply a coat of petroleum jelly to both the seal and cone and roller assembly prior to installation.
2. Install the axle housing on the axle shaft and, using a hammer and drift, stake the seal retainer to the housing in four equally spaced places.
3. Place the planet gear carrier assembly in the axle housing so that the planet gears mesh correctly with the planetary ring gear.

**NOTE: It will be necessary at this stage to adjust the axle shaft bearing pre-load for which the following procedure should be used.**

- a. Using the largest spacer available, .089" (2.261 mm), fit the spacer, retaining washer and tighten the axle shaft bolt.
- b. Set up a dial indicator as shown in Figure 5-8. It will be necessary to use an extended plunger on the dial indicator to enable a reading to be taken from the top of the axle shaft bolt.
- c. Set the dial indicator to zero and lift the axle housing. This can be done by prying up against the outer surface of the axle housing. Lifting the housing will result in a reading on the dial indicator. This is the free movement between the inner and outer bearing cone and roller assemblies and the cups.

## SECTION 5 - REAR AXLE AND BRAKES

---

### INSPECTION AND REPAIR

1. Inspect the steel fixed plates for wear and warp. The inspection should include the inner and outer brake housings. Replace parts which are scored or warped.
2. Inspect the rotating discs for wear and warp. Replace the discs if the friction material has worn to the bottom of any grooves, or if the plates are warped more than 0.009".
3. Replace the actuating rod seal.

### REASSEMBLY

1. Place one actuating disc with the pockets uppermost on a flat surface and position a steel ball in each pocket.
2. Position the other actuating disc over the first with the pockets locating on the steel balls. The actuating lugs should be approximately 1" (25.4 mm) apart.

3. Install the four actuating disc return springs on the lugs on the inner edge of the actuating discs.
4. Install the actuating links and secure using the clevis pins, cotter pins and nuts.

### INSTALLATION

1. Install the brake actuating assembly and disc assemblies as described in "Rear Axle Shaft Assembly."
2. Install the axle housing to the rear axle center housing, and install the rear axle assembly as described in Section 10.
3. Reconnect the brake actuating linkage and adjust the brake linkage as described in Section 10.

SECTION 5 - REAR AXLE AND BRAKES

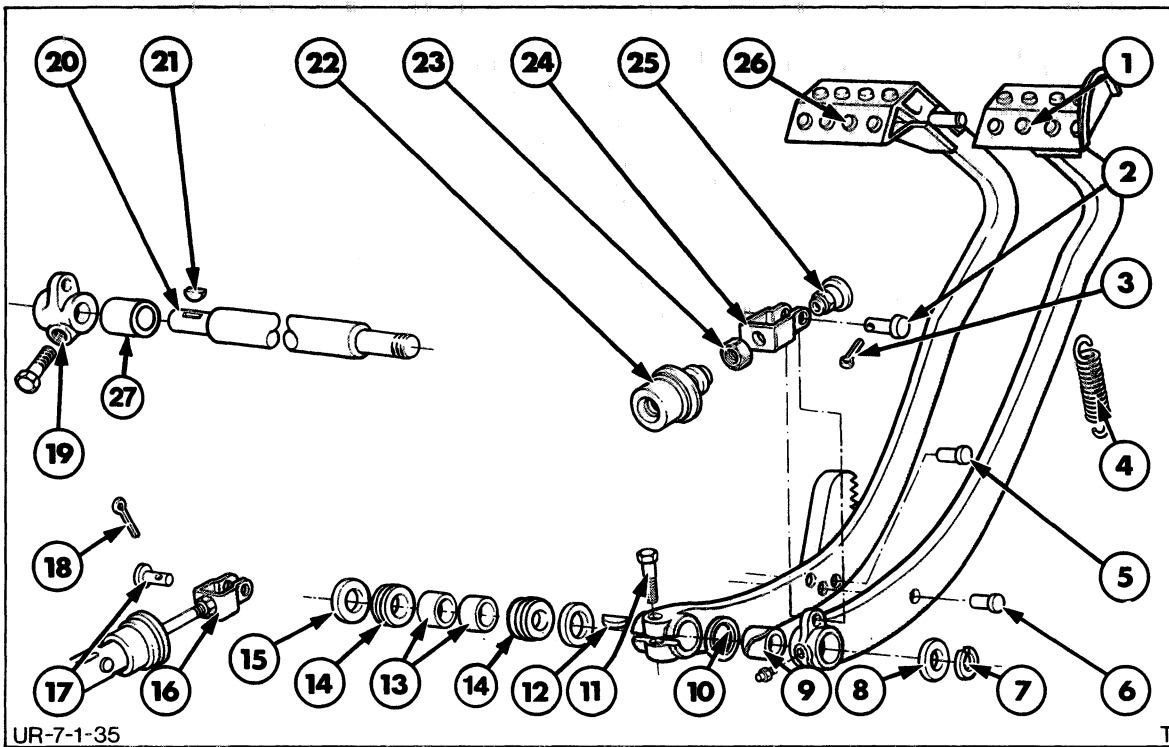

UR-7-1-35

TI

FIGURE 5-35

Brake Linkage Components

- |                 |               |
|-----------------|---------------|
| 1 R.H. pedal    | 15 Washer     |
| 2 Clevis pin    | 16 Clevis     |
| 3 Cotter pin    | 17 Clevis pin |
| 4 Return spring | 18 Cotter pin |
| 5 Spring stud   | 19 Lever      |
| 6 Spring stud   | 20 Shaft      |
| 7 Snap ring     | 21 Key        |
| 8 Washer        | 22 Seal       |
| 9 Bushing       | 23 Locknut    |
| 10 Washer       | 24 Clevis     |
| 11 Bolt         | 25 Adjuster   |
| 12 Key          | 26 L.H. pedal |
| 13 Bushing      | 27. Spacer*   |
| 14 Seal         |               |

\* Used with torque convertor transmission

SECTION 6 - POWER TAKE-OFF

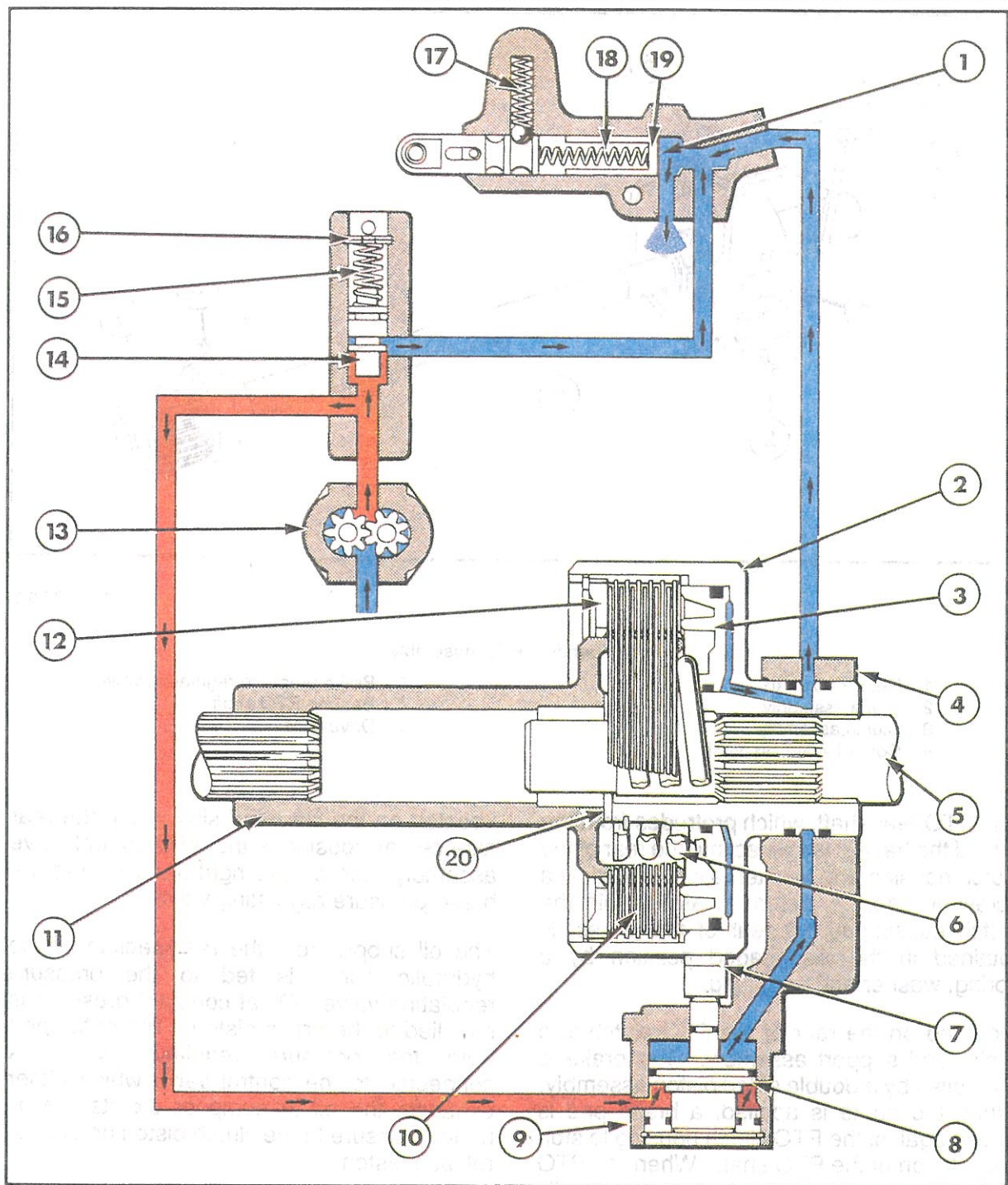

Pressure Oil

Exhaust Oil

FIGURE 6-4

- Oil Flow In Disengaged Position
- |                              |  |   |
|------------------------------|--|---|
| 1 Control valve piston       | 8 Brake piston                             | 15 Brake pressure regulating valve spring |
| 2 Clutch housing             | 9 Brake housing                            | 16 Shims                                  |
| 3 Clutch piston              | 10 Clutch discs                            | 17 Control valve detent                   |
| 4 Support assembly           | 11 Coupling                                | 18 Control valve spring                   |
| 5 Rear shaft                 | 12 Pressure plate                          | 19 Shims                                  |
| 6 Clutch spring              | 13 PTO pump                                | 20 Thrust washer                          |
| 7 Brake arm and pad assembly | 14 Brake pressure regulating valve plunger |   |

SECTION 6 - POWER TAKE-OFF

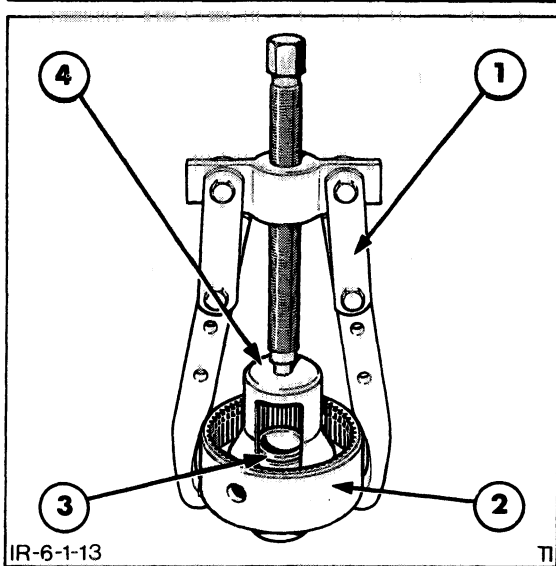

FIGURE 6-14

Compressing Clutch Spring

- 1 Puller, tool no. 1003 or FNH09516
- 2 Clutch housing
- 3 Snap ring
- 4 Compressor, tool no. FT4101 or FNH01312

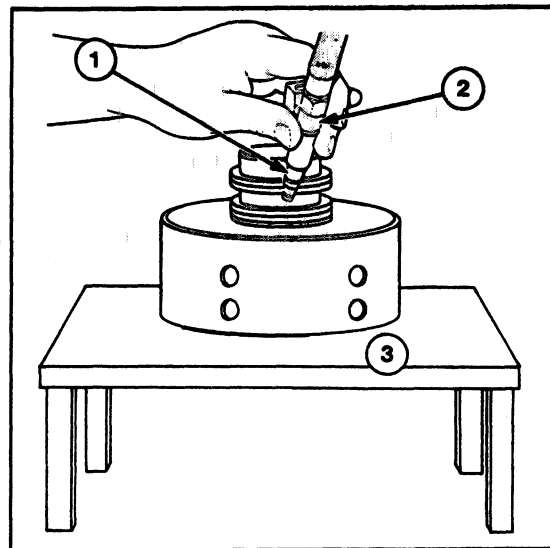

FIGURE 6-15

Clutch Piston Removal

- 1 Tire valve
- 2 Air-line
- 3 Clutch housing

3. Using puller, tool No. 1003 or FNH09516 and compressor, tool No. FT4101 or FNH01312, or a suitable press, compress the clutch piston return spring and remove the snap ring, Figure 6-14.

4. Slowly release the puller, then remove the retaining washer and return spring.

5. Use an air-line and a tire valve to extract the piston from the clutch housing, Figure 6-15.

6. Remove the housing and piston sealing rings.

## SECTION 7 - STEERING AND FRONT AXLE

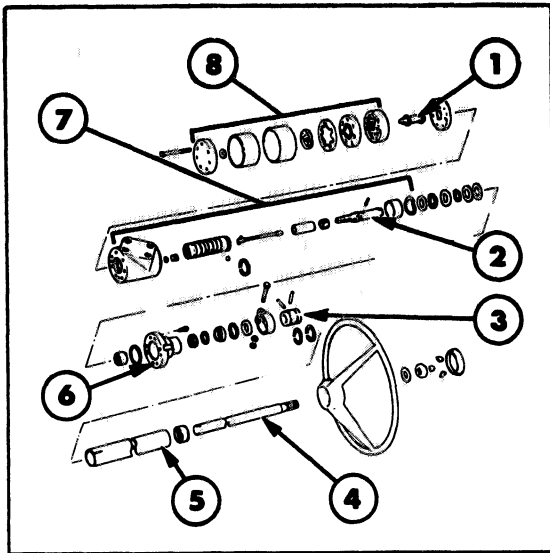

FIGURE 7-2

### Steering Motor Assembly

- 1 Drive link
- 2 Input shaft
- 3 Coupling
- 4 Steering column shaft
- 5 Outer tube
- 6 Top cover
- 7 Linear control valve
- 8 Metering valve

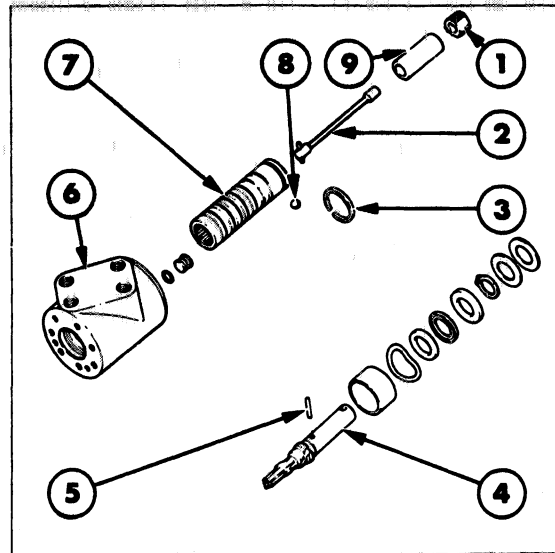

FIGURE 7-3

### Steering Motor Control Valve Section

- 1 Drive ring
- 2 Torsion bar
- 3 Retaining ring
- 4 Input shaft
- 5 Pin
- 6 Steering motor housing
- 7 Spool
- 8 Actuating ball
- 9 Spacer

## STEERING MOTOR

The hydrostatic steering motor, Figure 7-2, utilizes a linear control valve to control the direction of the steered wheels and a metering unit to control the rate of turn. In the event of pump failure, the wheels can be turned manually with the metering unit functioning as a hydraulic pump.

Port identification on the motor is cast in raised letters on the valve housing. The pressure port is identified "IN", the return port "OUT", the right turn port "RT", and the left turn port "LT".

## CONTROL VALVE SECTION

The control valve section, Figure 7-3, directs the hydraulic oil to and from the metering unit and steering cylinder, and regulates the pressure of the oil flowing to the steering cylinder. The lower end of the input shaft is bored to receive the top of the torsion bar. The torsion bar is pinned to the input shaft, extends

through the spool and is linked with the drive link in the metering system. The drive link is splined to and turns the rotor in the stator assembly. Thus, the torsion bar is the principal link between the input shaft and the metering system.

The lower edge of the input shaft is splined to engage and drive the drive ring. The drive ring is externally splined to engage and drive the spool. The drive ring splines are wider than the input shaft splines allowing a predetermined amount of free play. This provides a mechanical link between the shaft and spool for manual steering in event of pump failure, and limits the amount of twist on the torsion bar.

SECTION 7 - STEERING AND FRONT AXLE

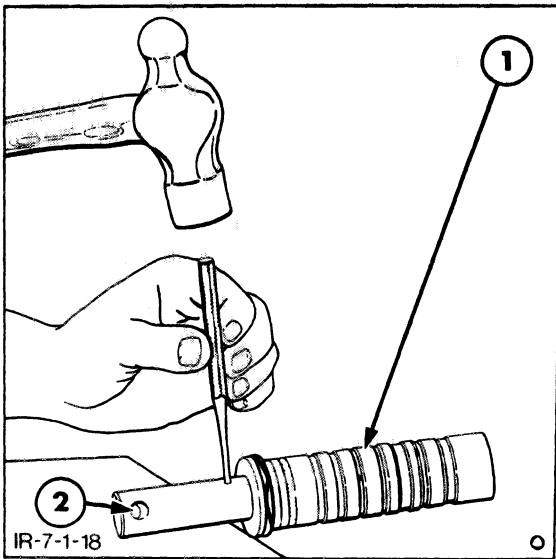

FIGURE 7-18

Steering Motor Input Shaft and Spool

- 1 Spool
- 2 Input shaft

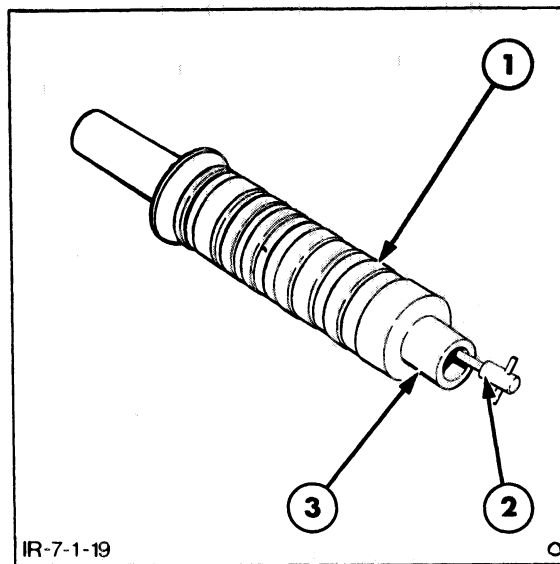

FIGURE 7-19

Torsion Bar and Spool

- 1 Spool
- 2 Torsion bar
- 3 Spacer

- 16. Remove the upper cover dirt seal. Extract the circlip and remove and discard the stepped washer and seal.
- 17. Remove the circlip, thrust washer, thrust bearing, thrust washer, spring washer and spacer from the input shaft.

- 18. Use a punch 0.12" (3 mm) maximum diameter and 0.63" (16 mm) minimum length, to remove the torsion bar retaining pin. Place the input shaft on a block of wood and use light hammer blows to remove the pin, Figure 7-18.
- 19. Invert the spool assembly and allow the torsion bar and spacer to fall free, Figure 7-19. Do not remove the pin from the end of the torsion bar.

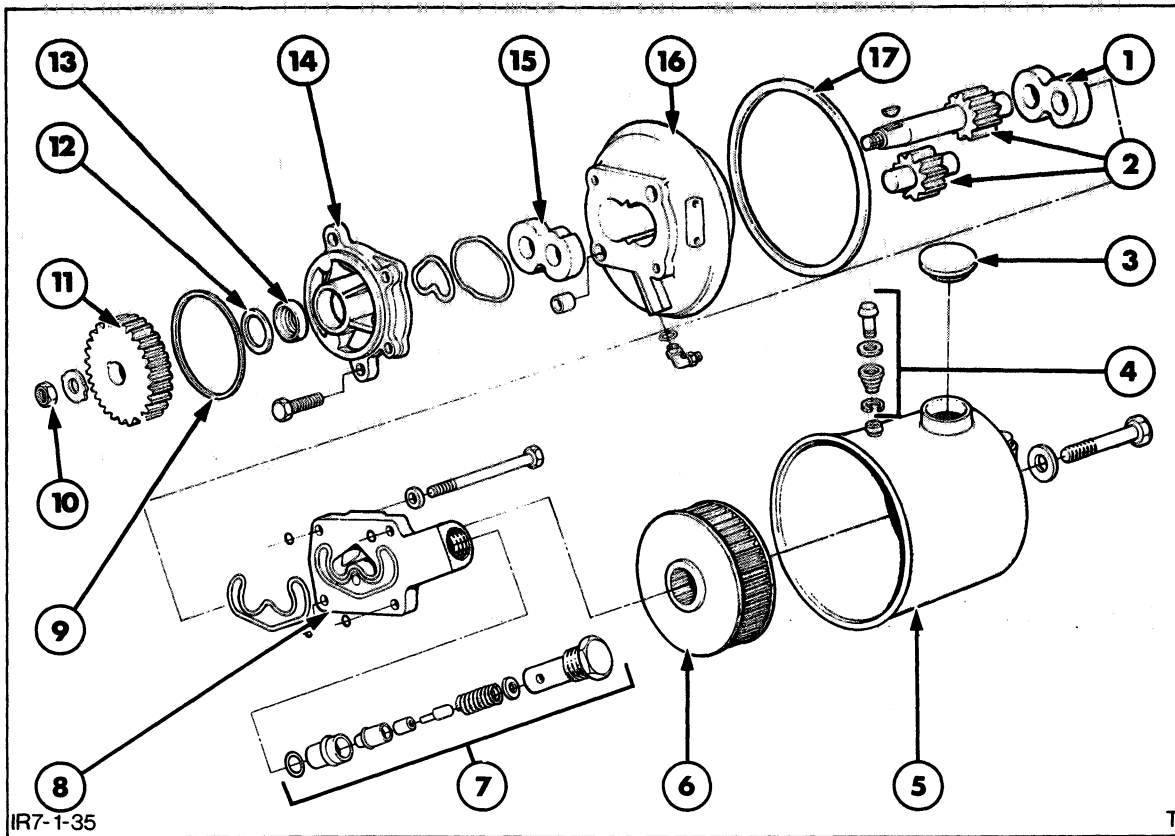

FIGURE 7-34

## Steering pump and Reservoir

- |                         |                             |
|-------------------------|-----------------------------|
| 1 Bearing block         | 10 Drive gear retaining nut |
| 2 Pump gear set         | 11 Pump drive gear          |
| 3 Reservoir filler cap  | 12 Circlip                  |
| 4 Breather assembly     | 13 Drive shaft oil seal     |
| 5 Reservoir             | 14 Pump flange              |
| 6 Filter                | 15 Bearing block            |
| 7 Relief valve assembly | 16 Pump body                |
| 8 Pump end cover        | 17 Reservoir O ring seal    |
| 9 O ring seal           |                             |

**DISASSEMBLY**

Refer to Figure 7-34 for component identity.

1. Remove the reservoir retaining bolt and pull off the reservoir casing. Discard the large O ring seal and filter element.
2. Straighten the tab on the lock washer locating the drive gear retaining nut. Remove the nut, lock washer and drive gear.
3. Remove the key from the drive gear shaft.
4. Remove the pressure relief valve from the pump body.
5. Remove the four bolts and separate the pump end cover and pump flange from the pump body.
6. Noting their positions relative to the pump body for reassembly, remove the bearing blocks and pump gears.
7. Remove the snap ring retaining the drive shaft oil seal in the pump flange and remove the oil seal.

## TWO WHEEL DRIVE AXLE

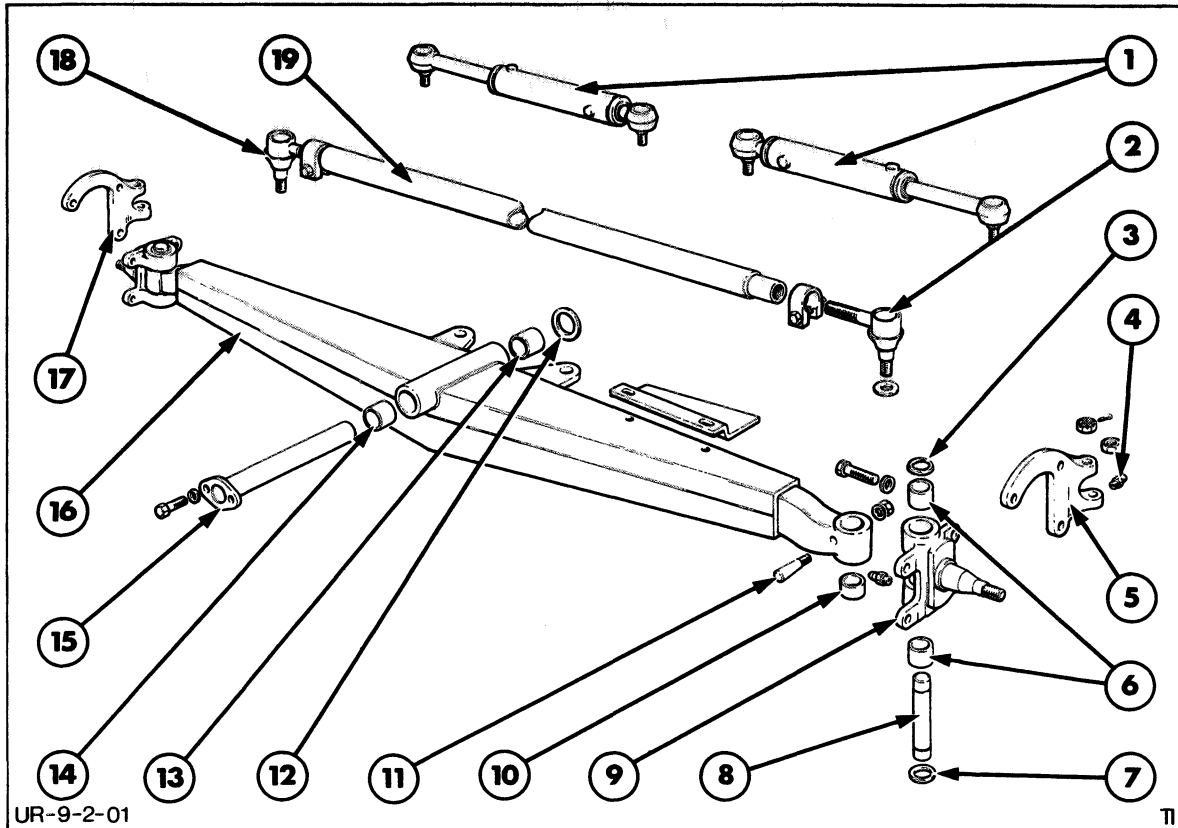

FIGURE 7-40

### Front Axle Assembly

- |                             |                                 |
|-----------------------------|---------------------------------|
| 1 Cylinder assembly         | 11 Spindle tapered locking bolt |
| 2 Connecting rod end - L.H. | 12 Thrust washer                |
| 3 Dust seal                 | 13 Pivot pin bushing - rear     |
| 4 Grease fitting            | 14 Pivot pin bushing - front    |
| 5 Spindle arm - left        | 15 Pivot pin                    |
| 6 Spindle bushing           | 16 Front axle assembly          |
| 7 Dust seal                 | 17 Spindle arm - right          |
| 8 Spindle pin               | 18 Connecting rod end - R.H.    |
| 9 Spindle assembly          | 19 Spindle arm connecting rod   |
| 10 Thrust bearing assembly  |                                 |

### DESCRIPTION

The front axle, Figure 7-40, is a fabricated box section tapered from the center to the ends and is slightly swept back. It is centrally mounted to the front motor support on one long pin.

Castings, machined to receive the wheel spindle pins, are welded to the ends of the axle. The wheel spindle assemblies are located on the spindle pins by means of bushings at the upper and lower ends. A

thrust bearing is located at the lower end of each spindle pin to support vertical thrust. The spindle pins and wheel spindle assemblies are held in place by a tapered locking pin through the axle castings and the spindle pins.

The steering arms are bolted to the outer surfaces of the wheel spindle assemblies. The steering arms are connected by means of a connecting rod.

The front wheel tread is 58" (1473 mm) and is not adjustable.

## PLANETARY REDUCTION ASSEMBLY AND WHEEL HUBS - OVERHAUL

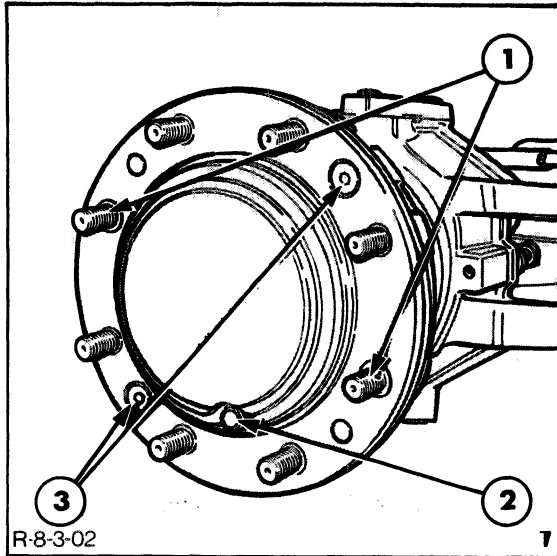

FIGURE 7-51

### Planetary Carrier Retainers

- 1 Shouldered wheel studs
- 2 Filler/drain plug
- 3 Socket screws

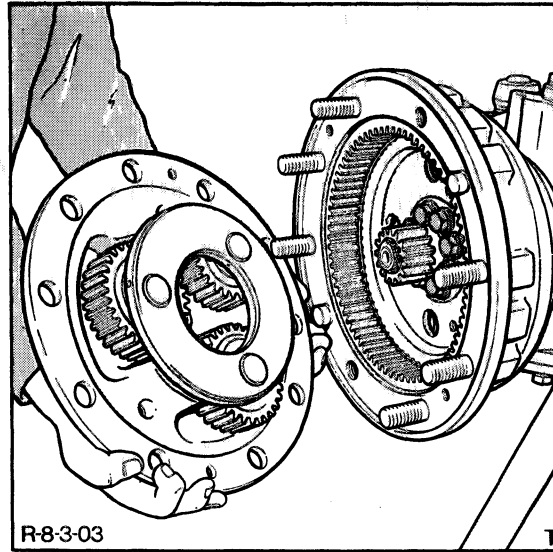

FIGURE 7-52

### Removing Planetary Carrier from Hub Assembly

## REMOVAL

1. Position the unit on a hard level surface, lower the loader arms, apply the parking brake and block the rear wheels. Disconnect the battery.
  2. Jack up the front axle and securely support the front of the unit. Remove the front wheel.
  3. Turn the hub so that the filler/drain plug is at its lowest point and drain the hub oil.
  4. Remove the two 8 mm socket screws and the two shouldered wheel studs, Figure 7-51, securing the planetary carrier assembly to the hub assembly.
  5. Gently tap the planetary carrier with a soft mallet and using the slots provided, lever the carrier from the hub.
- Carefully remove the planetary carrier assembly, Figure 7-52. Take care not to misplace the thrust pad positioned in the center of the carrier.

SECTION 7 - STEERING AND FRONT AXLE

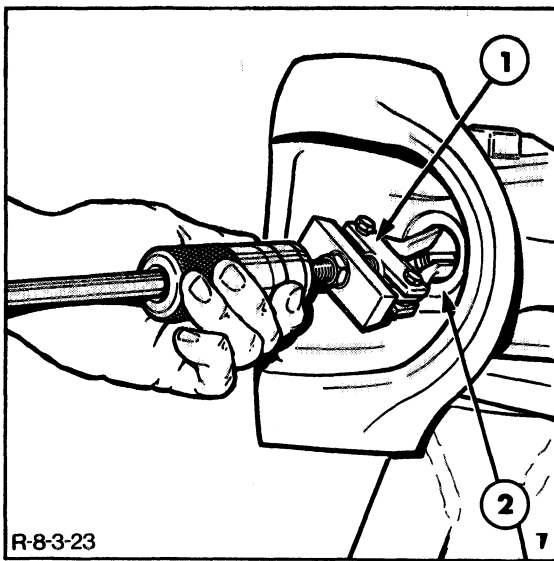

FIGURE 7-70

Removing Axle Shaft Oil Seal from Axle Casing

- 1 Puller tool no. 954C or FNH09527
- 2 Oil seal

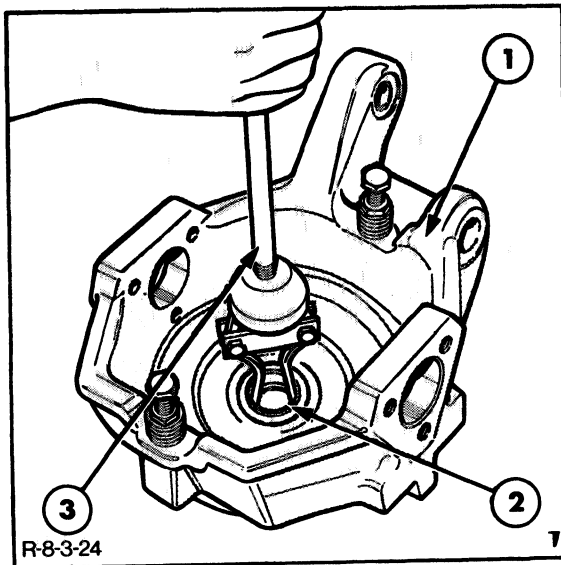

FIGURE 7-71

Removing Oil Seal from Swivel Casing

- 1 Swivel casing
- 2 Oil seal
- 3 Puller tool no. 954C or FNH09508

- 4. Remove the axle shaft oil seals from the axle center casing, Figure 7-70, and the swivel casing assembly, Figure 7-71.
- 5. Inspect the axle shaft bushings in the swivel casing and the axle center casing. If these bushings are worn or damaged, remove them using tool No. 943 and 943S (FNH09507 and FNH09567) or tool No. 954C (FNH09527), Figure 7-72.

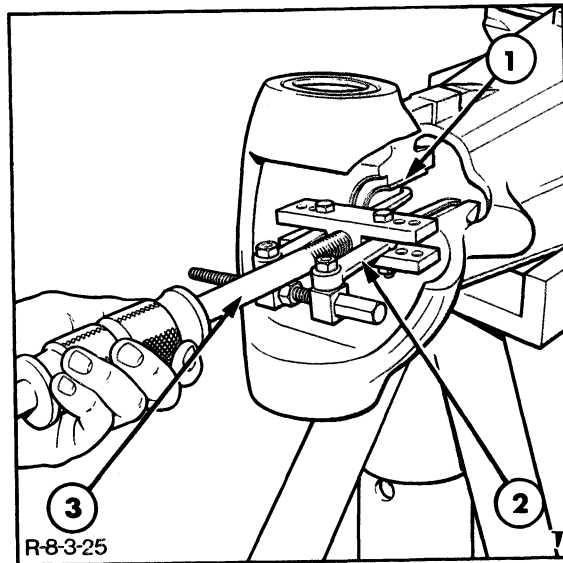
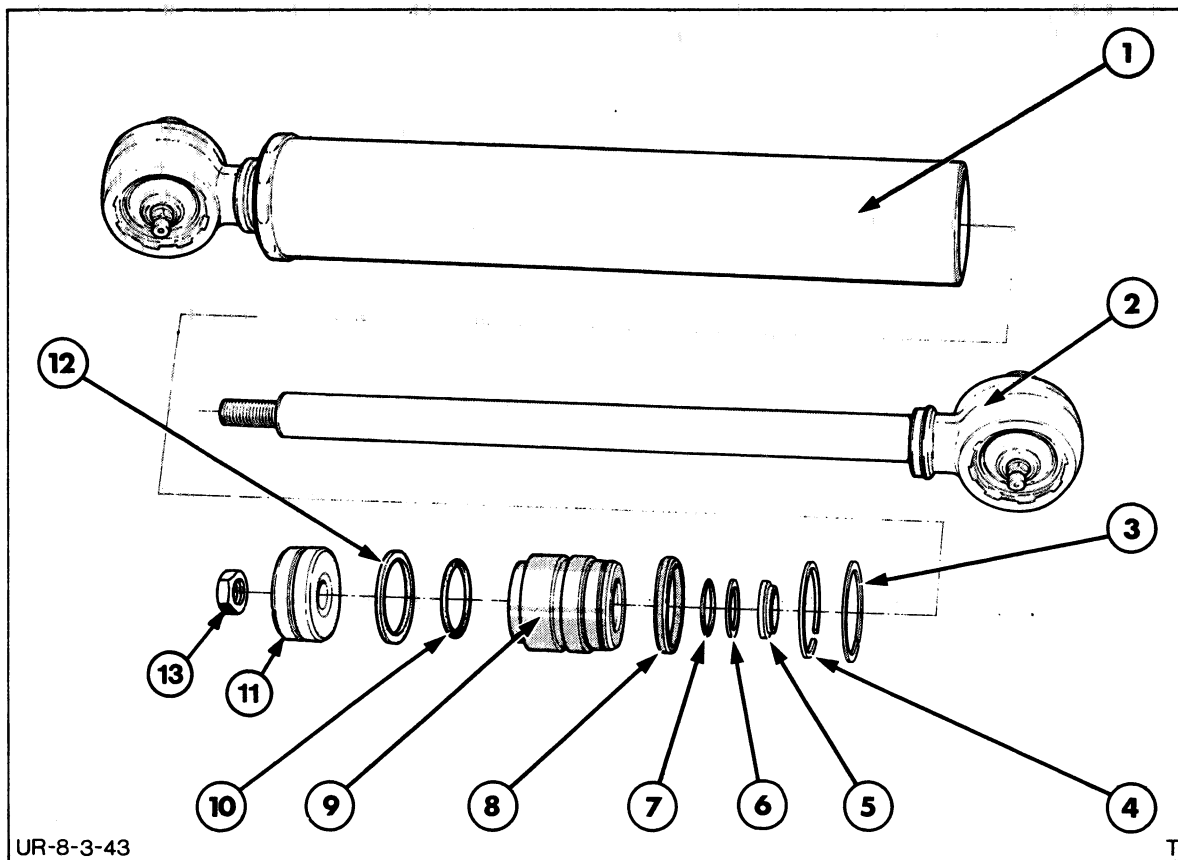

FIGURE 7-72

Removing Axle Shaft Bushing from Axle Casing

- 1 Bushing
- 2 Puller tool no. 943 or FNH09507
- 3 Slide hammer tool no. 943S or FNH09567

SECTION 7 - STEERING AND FRONT AXLE



UR-8-3-43

TI

FIGURE 7-90

Steering Cylinder - Exploded View

- |                           |                     |
|---------------------------|---------------------|
| 1 Cylinder barrel         | 8 O ring            |
| 2 Cylinder rod            | 9 Gland             |
| 3 Gland - outer snap ring | 10 O ring expander  |
| 4 Gland - inner snap ring | 11 Piston           |
| 5 Dirt seal               | 12 Piston seal      |
| 6 Back-up ring            | 13 Cylinder rod nut |
| 7 Outer gland seal        |                     |

## SECTION 7 - STEERING AND FRONT AXLE

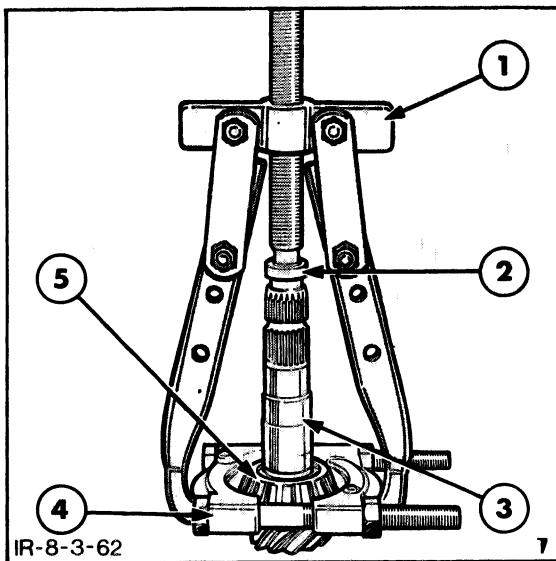

FIGURE 7-107

### Removing Pinion Inner Bearing Race

- 1 Puller tool no. 1003 or FNH09516
- 2 Shaft protector
- 3 Pinion
- 4 Pulling attachment tool no. 951 or FNH09190
- 5 Bearing inner race

## INSPECTION AND REPAIR

1. Clean all the components in a suitable solvent and allow to air dry.
2. Clean the differential support housing mounting face and the mating face of the axle casing, removing all traces of sealant.

3. Clean all traces of locking compound from the ring gear securing bolts and any locating dowels.
4. Carefully inspect the ring gear and pinion teeth. If worn or damaged, both gears must be replaced. They are only serviced as a matched pair.
5. Inspect the differential side bearings; where necessary, pull off the inner races using tool No. 1003 (FNH09516) and tool No. 951 (FNH09190).
6. Inspect the pinion bearings where necessary, pull off the inner bearing inner race using tool Nos. 951 and 1003 (FNH09190 and FNH09516), Figure 7-107. Note that there is a shim positioned between the pinion inner bearing and the head of the pinion. Drive out the outer tracks from the differential support housing.
7. Inspect the differential gears, thrust washers and shafts for wear. Replace any worn or damaged items.
8. Inspect the side gears and the splines within each gear for damage.
9. Examine the thrust washer placed under the head of each side gear for wear and damage. Replace if necessary.
10. Visually, check the condition of the axle housing, the differential support housing and the differential gear housing.

**TRANSFER BOX - OVERHAUL**

FIGURE 7-122

**Selector Lever Removal**

- 1 Operating rod
- 2 Adjusting nuts
- 3 Selector lever
- 4 Transfer case assembly

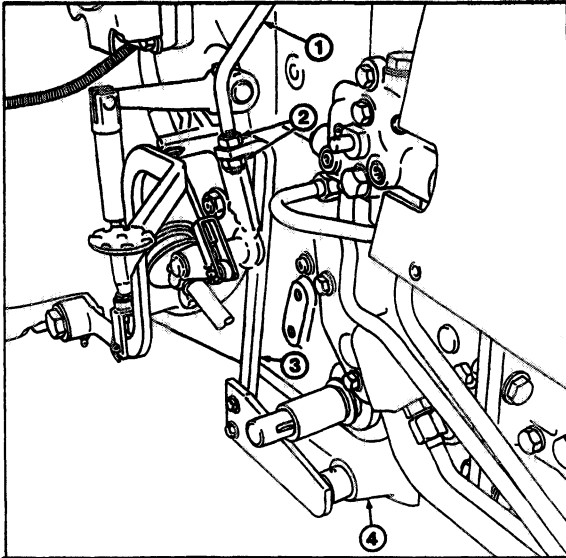
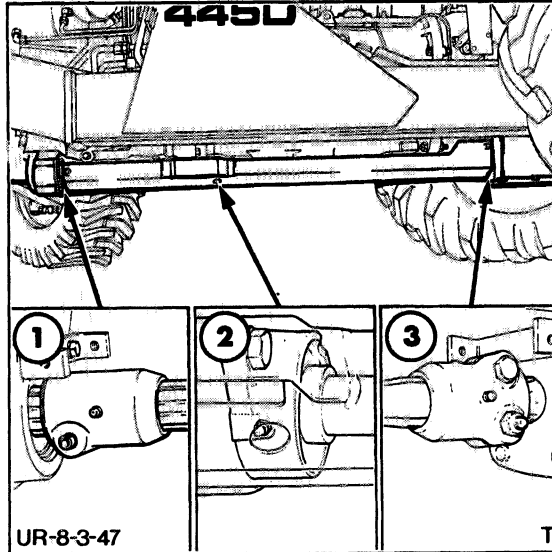

FIGURE 7-123

**Drive Shaft - Installation**

- 1 Front coupling
- 2 Center bearing
- 3 Rear coupling

**REMOVAL**

1. Remove the drain plug from the rear of the transfer box and allow the rear axle oil to drain into a suitable container.
2. Remove the adjusting nuts securing the control lever rod to the transfer box actuating lever.
3. Remove the drive shaft guard, Figure 7-123.
4. Disconnect the drive shaft coupler from the transfer box output shaft.

5. Support the weight of the transfer box on a trolley jack, or similar equipment, and remove the transfer box to center housing retaining bolts.
6. Carefully lower the transfer gear assembly and remove it from the rear axle center housing.

**DISASSEMBLY**

1. Using a suitable size straight punch, drive the roll pin out of the control lever arm and remove the arm, Figure 7-122.
2. Using a straight punch, drive the roll pin, Figure 7-125, out the bottom of the idler gear shaft and case web.

**SECTION 7 - STEERING AND FRONT AXLE**

---

---

Troubleshooting .....	8-74
Specifications .....	8-87
Special tools .....	8-91
<b>Loader Hydraulic System .....</b>	<b>8-92</b>
Loader hydraulic circuits .....	8-92
Reservoir and filter .....	8-96
Hydraulic pump .....	8-103
Hydraulic cylinders .....	8-109
Loader control valve .....	8-116
Loader frame, buckets, hoses and tubes .....	8-142
Specifications .....	8-162
<b>Section 9 – Cab .....</b>	<b>9-1</b>
Cab Pressurizer/Heater .....	9-5
Cab Glass Installation .....	9-8
Cab Removal .....	9-11
<b>Section 10 – Separating the Tractor .....</b>	<b>10-1</b>
Separating the Tractor Between the Transmission and the Rear Axle .....	10-1
Separating the Tractor Between the Transmission and Engine .....	10-3
Separating the Tractor Between the Front Axle and the Engine .....	10-7
Specifications and Special Tools .....	10-9
<b>Section 11 – Accessories .....</b>	<b>11-1</b>
Rear Tail/Stop Light Kit .....	11-1
Backup Alarm Wiring Kit .....	11-7
Hydraulic Pressure Tapping Manifold .....	11-14
Reduction Gear Set .....	11-19
Reduction Gearbox Installation Instructions .....	11-27
Brush Guard Kit .....	11-38
Canopy Kit .....	11-42
Coolant Corrosion Inhibitor/Filter Kit .....	11-43
Rotating Beacon .....	11-46
External Rear View Mirror .....	11-47
Stabilizer Kits .....	11-48
Telescoping Stabilizer Kit .....	11-53
Brake Pedal Conversion Kit .....	11-55
Interior Rear View Mirror .....	11-63
Security Lock-Up .....	11-64
3" Wide Seat Belt Kit .....	11-66

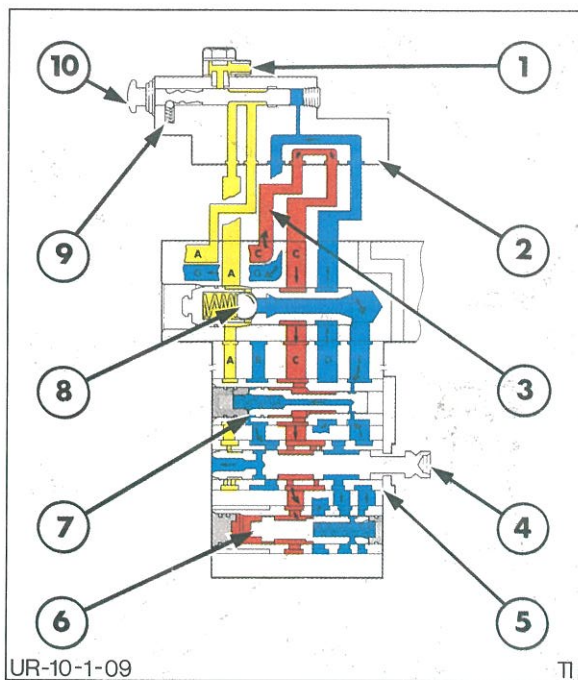

Full Flow Oil

Reduced Flow Oil

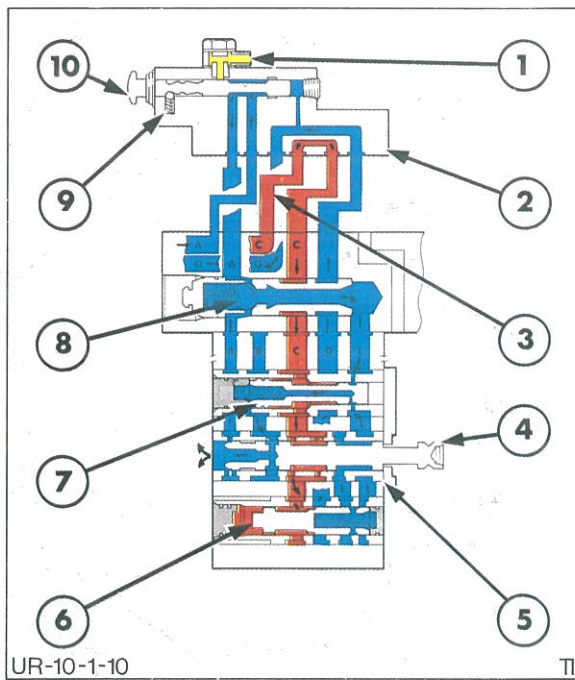

Reservoir Suction and Exhaust Oil

Trapped Oil

FIGURE 8-9

FIGURE 8-10

Oil Flow In Neutral

Oil Flow When Lowering

OIL FLOW IN LIFT CYLINDER VALVES

- |                         |                    |
|-------------------------|--------------------|
| 1 Aux. service supply   | 6 Feathering valve |
| 2 ASC valve             | 7 Unload valve     |
| 3 From main pump        | 8 Check valve      |
| 4 Control valve         | 9 Detent           |
| 5 Control valve bushing | 10 Control spool   |

## HYDRAULIC LIFT CYLINDER ASSEMBLY - OVERHAUL

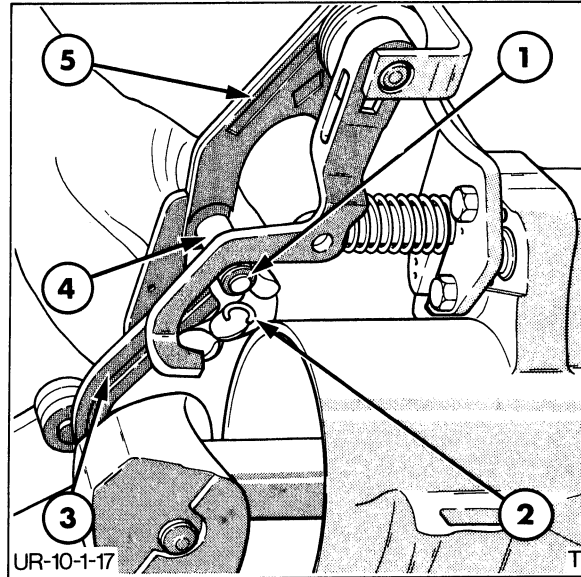

FIGURE 8-17

### Removing Draft Lever To Actuating Lever Pivot Pin Snap Ring

- 1 Pivot pin
- 2 Snap ring
- 3 Draft lever
- 4 Roller
- 5 Actuating lever

### REMOVAL

1. Remove the hydraulic lift cover.
2. Remove the snap ring from the end of the draft lever to actuating lever pivot pin, Figure 8-17.
3. Remove the four bolts securing the lift cylinder assembly to the lift cover. Move the lift arms to the raised position and remove the lift cylinder by carefully lifting off the locating dowels and moving sideways thereby enabling the draft lever to disengage from the pivot pin.
4. Place the lift cylinder assembly on a bench with the top face exposed.

## SECTION 8 - HYDRAULIC SYSTEMS

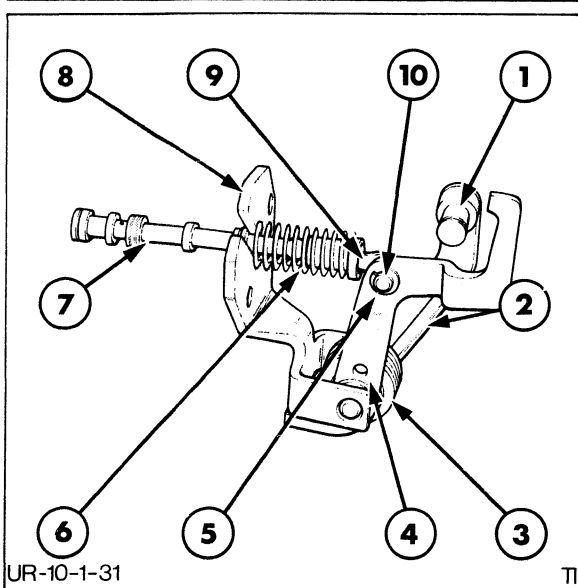

FIGURE 8-31

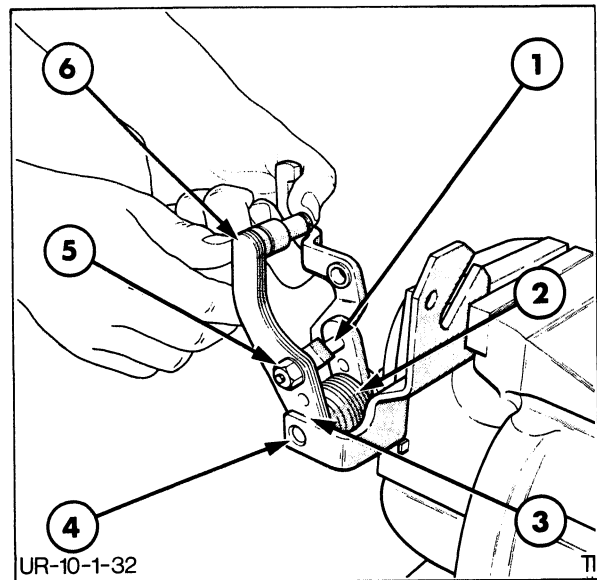

FIGURE 8-32

### Control Valve And Actuating Linkage

- 1 Pivot pin
- 2 Actuating lever
- 3 Torsion spring
- 4 Control valve lever
- 5 Snap ring
- 6 Control valve spring
- 7 Control valve
- 8 Bracket
- 9 Actuator
- 10 Actuator pin

### Removing The Adjustable Stop Eccentric

- 1 Eccentric
- 2 Torsion spring
- 3 Snap rings
- 4 Pivot pin
- 5 Adjustable stop nut
- 6 Actuating lever

7. Remove the three bolts securing the bracket to the rear of the lift cylinder. Carefully remove the bracket together with the control valve, control valve spring, control valve lever, torsion spring and actuating lever, Figure 8-31.
8. Remove the actuator pin snap ring, the actuator pin and the actuator. Then compress the control valve spring and carefully slide the control valve face off the bracket.
9. Mount the actuating linkage in a vice as shown in Figure 8-32.
10. Remove the adjustable stop nut and lock washer and, while applying pressure to the actuating lever, remove the eccentric. Relax the pressure on the actuating lever and allow the torsion spring to unwind.
11. Remove the snap rings between the levers and the bracket.
12. Extract the lever pivot pin from the bracket, then remove and separate the two levers and the torsion spring.
13. Unscrew the yoke at the rear of the draft control main spring.
14. Remove the three bolts securing the draft control main spring housing. Slide the housing, draft control main spring, spring seat and shims over the draft control main spring plunger.

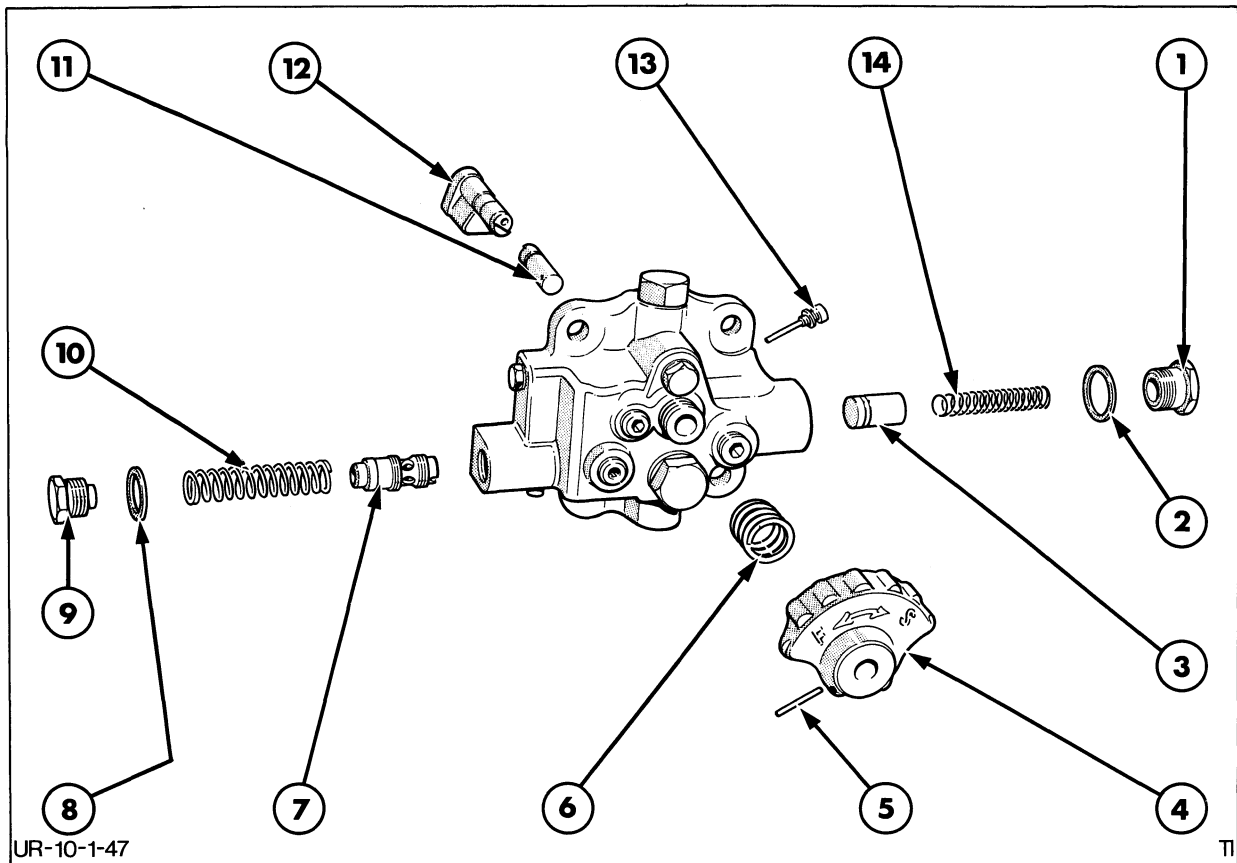

FIGURE 8-46

## Flow Control Valve Plate Disassembled

- |                              |                                      |
|------------------------------|--------------------------------------|
| 1 Oil cooler valve plug      | 8 Flow control valve seal            |
| 2 Oil cooler valve seal      | 9 Flow control valve plug            |
| 3 Oil cooler valve spool     | 10 Flow control valve spring         |
| 4 Flow control valve knob    | 11 Restrictor shaft                  |
| 5 Roll pin                   | 12 Restrictor                        |
| 6 Spring                     | 13 Restrictor retaining pin and seal |
| 7 Flow control valve plunger | 14 Oil cooler valve spring           |

**INSTALLATION**

1. The installation of the flow control valve plate follows the removal procedure in reverse.

**NOTE:** If the lower pressure tube is removed, fit new O rings and install the tube from beneath the center housing.

2. Adjust the flow control override adjuster.
3. Fill the rear axle with the correct grade and quantity of oil.

## HYDRAULIC PUMP - TRANSMISSION MOUNTED GEAR TYPE - DESCRIPTION AND OPERATION

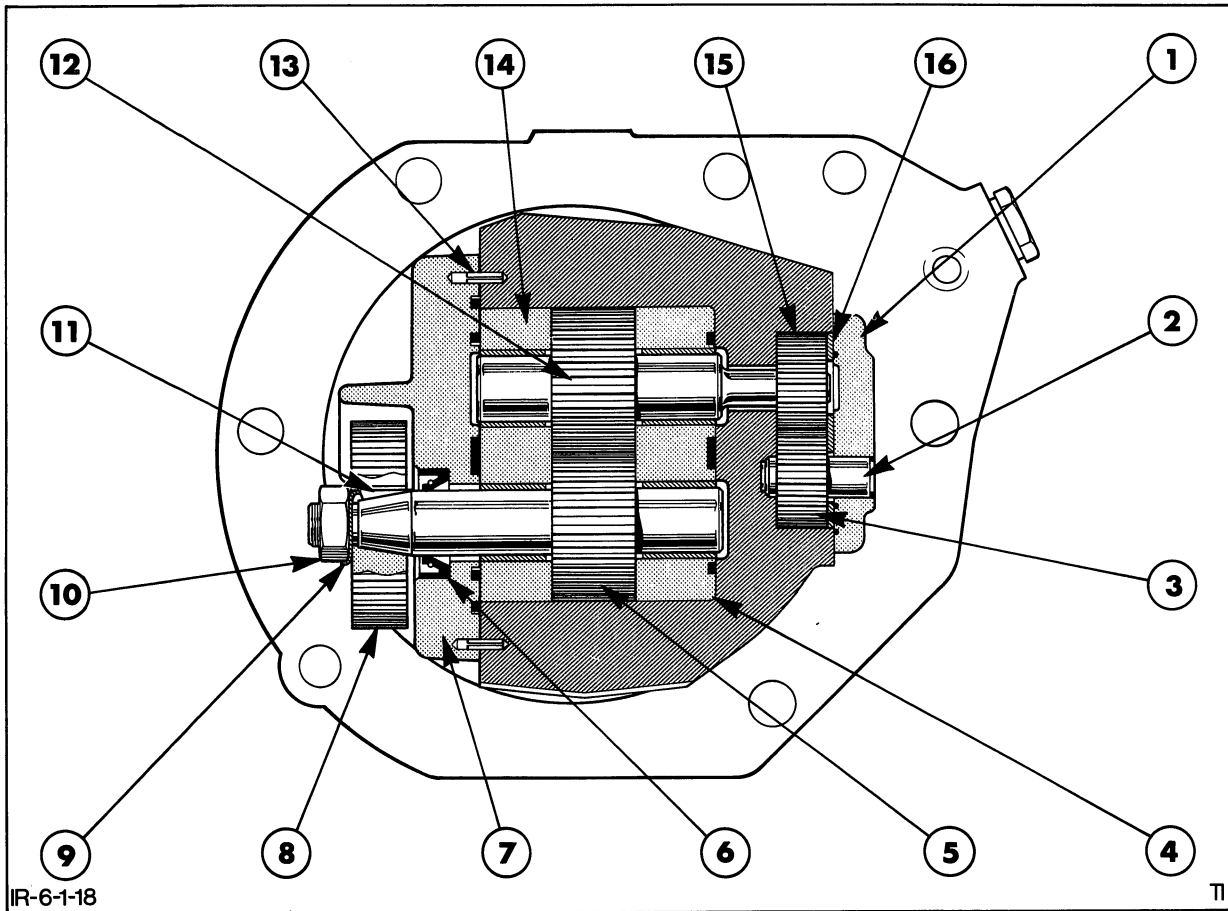

FIGURE 8-60

### Cross-Section Of Transmission Mounted Hydraulic Gear Type Pump

- |   |                        |    |                   |    |                    |
|---|------------------------|----|-------------------|----|--------------------|
| 1 | Rear cover             | 7  | Front cover       | 13 | Roll pin dowel     |
| 2 | Rear driven gear shaft | 8  | Driven gear       | 14 | Front gear bearing |
| 3 | Rear driven gear       | 9  | Tab washer        | 15 | Rear drive gear    |
| 4 | Rear gear bearing      | 10 | Nut               | 16 | Pressure plate     |
| 5 | Front drive gear       | 11 | Shaft key         |    |                    |
| 6 | Shaft seal             | 12 | Front driven gear |    |                    |

A cross-section of the transmission mounted gear-type hydraulic pump is shown in Figure 8-60.

The pump is a tandem gear-type unit mounted in the lower right hand side of the rear axle center housing.

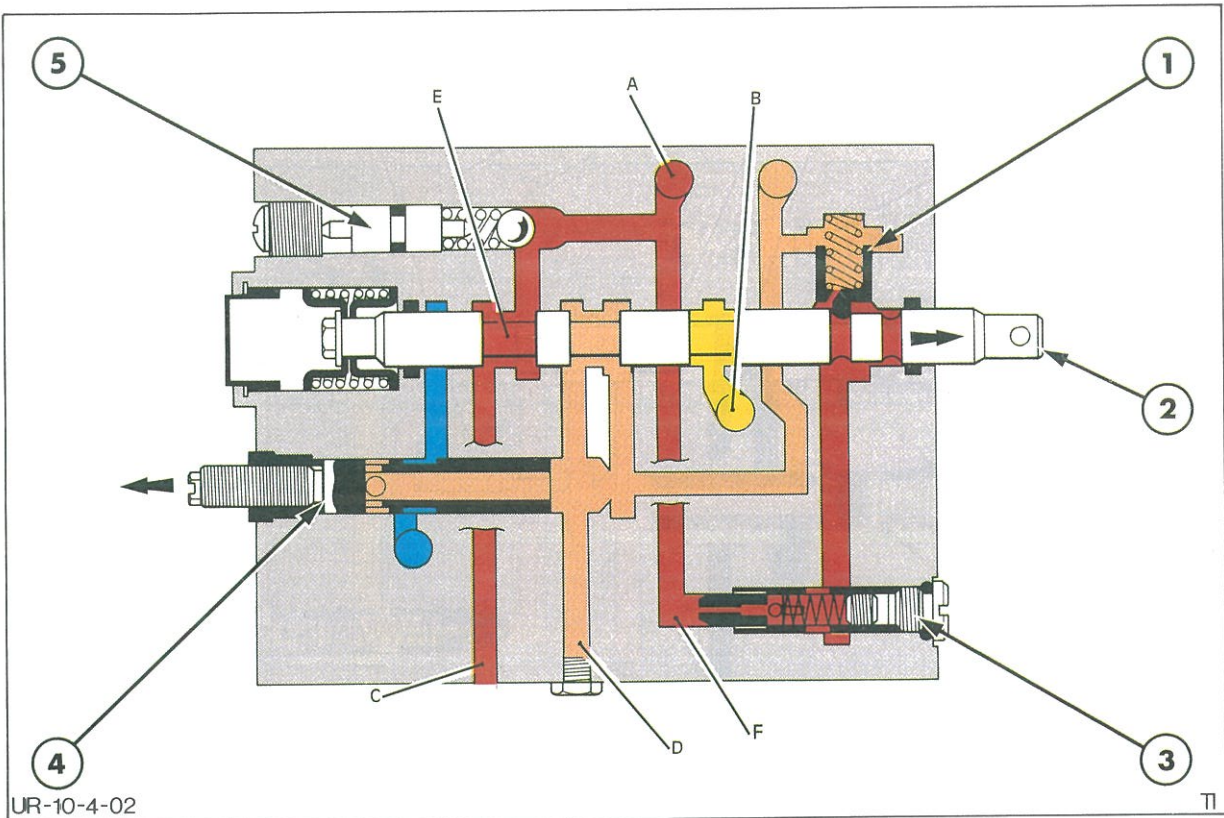

Pressurised Oil

Reduced Pressure Oil

Trapped Oil

Return Oil

FIGURE 8-70

Single Spool Control Valve - Raise Position With Single Acting Cylinder

- |                                |                             |
|--------------------------------|-----------------------------|
| 1 Spool detent                 | 4 Quick drop valve assembly |
| 2 Valve spool                  | 5 Check valve assembly      |
| 3 Detent regulating valve plug |                             |

Moving the spool outwards to the raise position, Figure 8-70, blocks the oil circulation between passages "A" and "B". This causes the pump pressure to increase which unseats the check valve and allows the oil to flow through the spool land at "E" to the cylinder via the lift port "C".

When the cylinder reaches the end of the travel, the increased pressure is sensed by the detent regulating valve through the passage "F".

At a specific pressure, just below the main tractor hydraulic system relief valve pressure setting, the detent regulating valve opens. This pressurized oil acts on the face of the spool detent which is forced back against the detent spring. With the detent lifted from the groove of the valve spool, the spool centering springs return the spool to the neutral position.

SECTION 8 - HYDRAULIC SYSTEMS

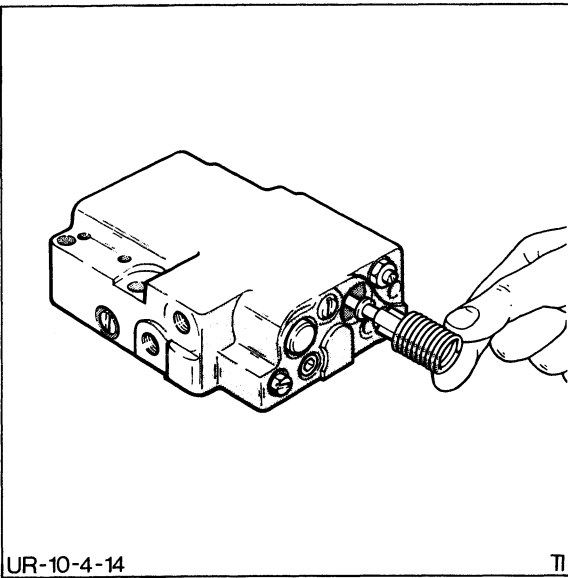

FIGURE 8-82

Withdrawing Control Valve Spool

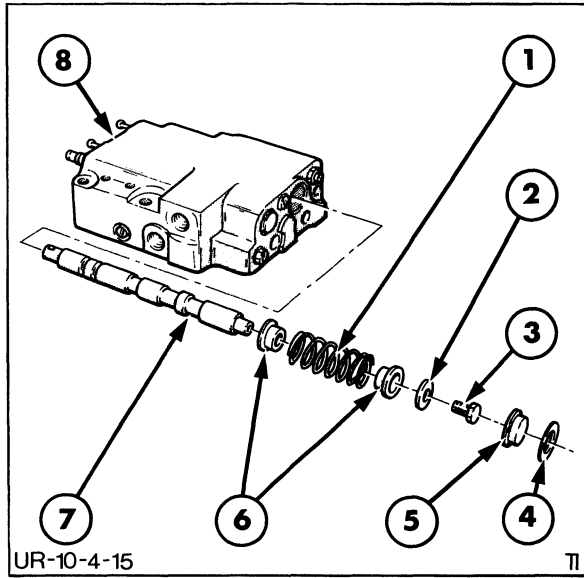

FIGURE 8-83

- Control Valve Spool Components
- |                          |                      |
|--------------------------|----------------------|
| 1 Spool centering spring | 5 Spring cap         |
| 2 Washer                 | 6 Spring cups        |
| 3 Retaining bolt         | 7 Valve spool        |
| 4 Retaining snap ring    | 8 Control valve body |

2. Gently tap the spool on the handle end and remove the spool from the centering spring end, Figure 8-82.

**NOTE:** For double spool valves, identify the spools relative to the bores as the spools and bores are a matched fit.

3. Remove the centering spring retaining screw and separate the washers, spring cups and spring, Figure 8-83.

**Check Valve**

1. Remove the check valve retaining set screw and remove the plug, spring and ball, Figure 8-84.

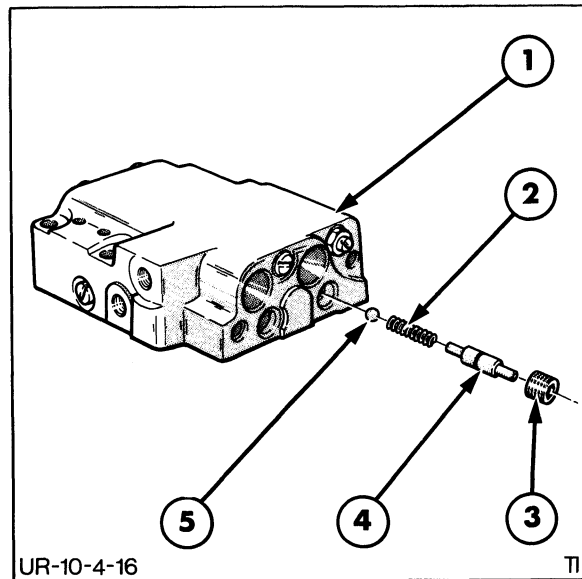

FIGURE 8-84

- Check Valve Components
- |                        |
|------------------------|
| 1 Control valve body   |
| 2 Check valve spring   |
| 3 Retaining set screws |
| 4 Check valve plug     |
| 5 Check valve ball     |

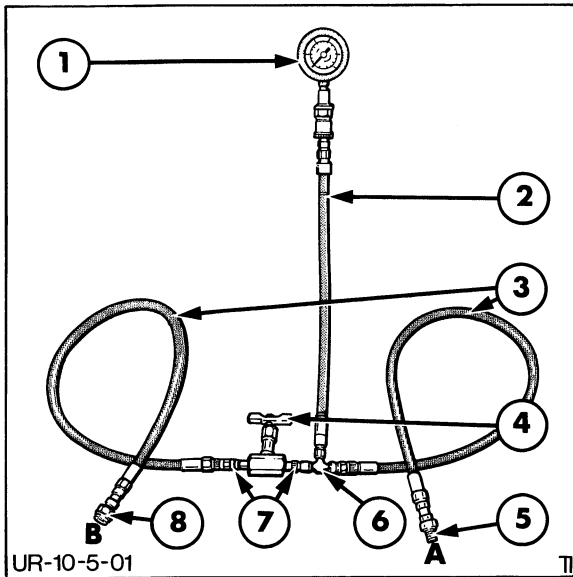

FIGURE 8-88

**Test Equipment**

- A To pressure tube
- B To pressure tube elbow
- 1 Gauge 0.5000 psi no. 2028 or FNH02028
- 2 Hose no. 7099 or FNH07099
- 3 Hose no. 6661 (2) or FNH06661
- 4 Valve no. 1394 or FNH01394
- 5 Fitting no. 0741 or FNH00741
- 6 Tee no. 0027 or FNH00027
- 7 Fitting no. 0035 (2) or FNH00035
- 8 Fitting no. 0724 or FNH00724

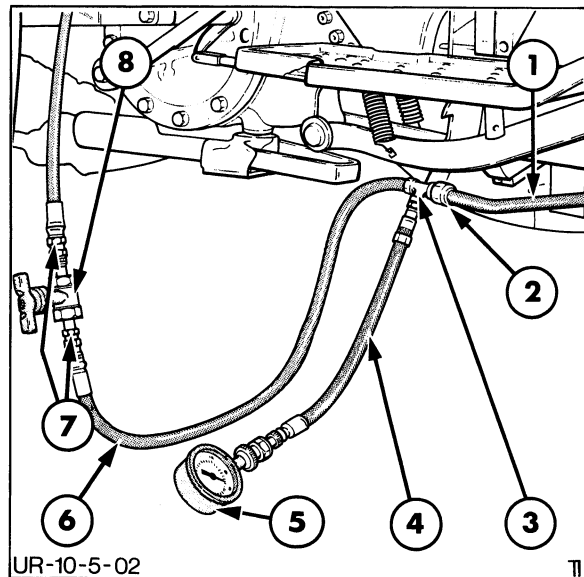

FIGURE 8-89

**Pressure Testing Engine Mounted Gear Pump**

- 1 Pump pressure pipe
- 2 Adaptor, tool no. 0741 or FNH00741
- 3 "T" fitting, tool no. 0027 or FNH00027
- 4 Adapter, tool no. 0035 (2) or FNH00035
- 5 Load valve, tool no. 1394 or FNH01394
- 6 Hose assembly, tool no. 7099 or FNH07099
- 7 Pressure gauge, tool no. 2028 or FNH02028
- 8 Hose assembly, tool no. 6661 (2) or FNH06661

**HYDRAULIC SYSTEM PRESSURE AND FLOW TESTS**

The following tests may be performed to determine the condition of the hydraulic pumps utilized on Ford tractors:

- A pump pressure test utilizing a pressure gauge only.
- A pump pressure and flow test utilizing a Hydra-Analyzer or similar test equipment.

**PUMP PRESSURE TEST**

The following hydraulic pump pressure tests are for dealers not having a flow and pressure test unit and who are using a pressure gauge only.

while flow cannot be checked with this test procedure, if the specified system pressure can be obtained, it is an indication that the pump is in reasonably good condition.

**PRESSURE TEST SET-UP:****Models 250C, 345D, 445D, 260C, and 545D**

- Gear Pump (Engine Mounted)

**Test Equipment Installation:**

Disconnect the pump pressure tube at the elbow on the underside of the rear axle center housing and connect the test equipment as shown in Figures 8-88 and 8-89.

**TORQUE SPECIFICATIONS**

	<b>Ft. Lbs.</b>	<b>N-m</b>	<b>Kgm</b>
Lift Cylinder Retaining Bolts	75-80	102-109	10.4-11.0
Lift Cover Retaining Bolts	70-85	95-115	9.7-11.7
Accessory Cover Lift Cover Bolts	50-70	68-95	7.0-9.7
Center Bolt	12-15	17-20	1.7-2.1
Control Valve Baffle Plate and Rear Plate Retaining Bolts	24-30	33-41	3.3-4.2
Quadrant Assembly to Quadrant Support Retaining Bolts	23-30	31-41	3.2-4.2
Quadrant Support to Lift Cover Housing Retaining Bolts Control Valve Lever	35-47	48-64	4.8-6.5
Draft Control Spring Housing Bolts	30-50	41-68	4.2-7.0
Check Valve Plug	45-55	61-75	6.2-7.6
Flow Control Plate Retaining Bolts	35-47	48-64	4.8-6.5
Hydraulic Piston Pump Cover Bolts	35-40	48-54	4.8-5.5
Hydraulic Piston Pump Drive Housing Bolts	35-40	48-54	4.8-5.5
Hydraulic Piston Pump Shaft Nut	25-35	34-48	3.5-4.8
Lift Cylinder Safety Valve	75-90	102-122	10.4-12.4
Engine Mounted Gear Pump to Engine Retaining Bolts	26-34	35-46	3.5-4.7
Hydraulic Gear Pump to Transmission Housing Retaining Bolts	43-57	58-77	5.9-7.9
Hydraulic Gear Type Pump Through Bolts	35-40	48-54	4.8-5.5
Draft Control Adjuster Rod Lock Nut	7-10.5	9.5-14	1.0-1.4
Position Control Adjuster Rod Lock Nut	7-10.5	9.5-14	1.0-1.4
Eccentric Adjustable Stop Lock Nut	23-30	33-41	3.2-4.1
<b>Remote Valve</b>			
Spool Centering Spring Retaining Bolt	5-8	7-11	0.7-1.1
Quick Drop Valve Sleeve (Left-Hand Thread)	7-9	9-12	1.0-1.2
Float Valve - Maximum "in" Position Torque	4	5	0.5
Remote Control Valve Retaining Bolts	35-47	47-63	4.8-6.5
Control Lever Retaining Nut	15-21	20-28	2.1-2.9

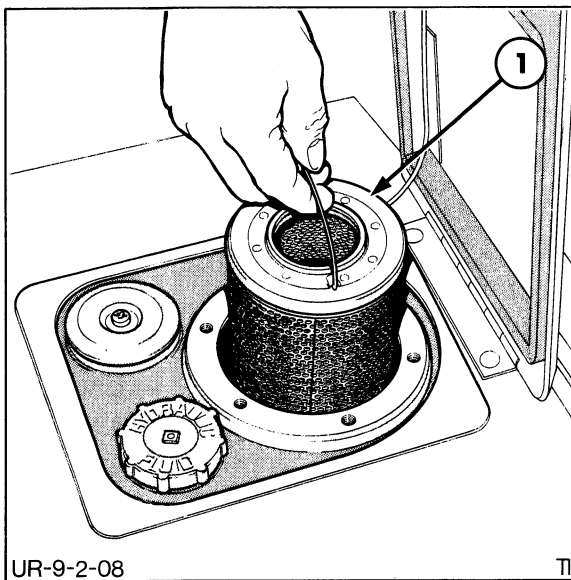

FIGURE 8-108

## Hydraulic Oil Filter Removal

- 1 Oil filter

4. Remove and discard the filter element from the reservoir assembly, Figure 8-108.

**NOTE:** The filter element must be removed slowly and level from the reservoir so that the particles are retained on the lip of the filter end.

5. Remove the by-pass valve tube retaining bolts and the tube as an assembly from within the reservoir, Figure 8-109.
6. Invert the tube and position on a bench. Using a suitable pair of snap-ring pliers, remove the by-pass valve retaining snap ring and remove the by-pass valve from the tube.
7. Invert the tube and remove the by-pass tube O ring from inside of the tube and discard.
8. Thoroughly wash and clean the inside of the reservoir and ensure that all contaminants have been removed. Invert the reservoir and allow to drain and dry.

**REASSEMBLY**

1. Install a new O ring seal into the by-pass valve tube.

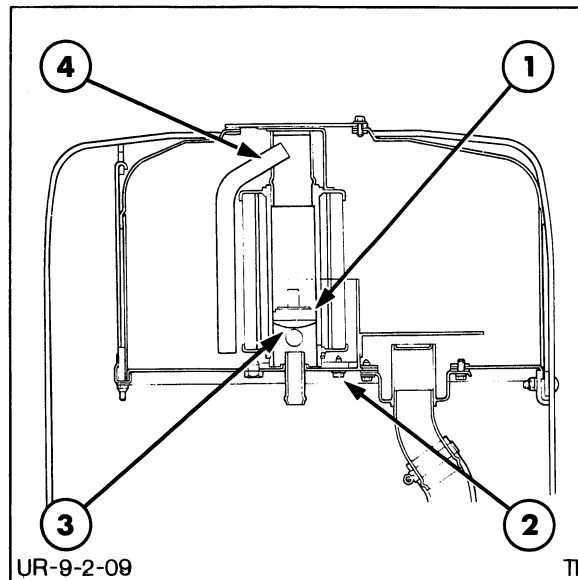

FIGURE 8-109

## Hydraulic Filter By-Pass Valve

- 1 By-pass valve tube assembly
- 2 Retaining bolt
- 3 By-pass valve
- 4 By-pass tube

2. Install the by-pass valve into the tube and retain in position using the appropriate snap ring.
3. Install the tube assembly into the reservoir and retain in position with the retaining bolts.
4. If the tube assembly retaining bolt seals were damaged during disassembly, replace the bolts or alternatively add thread sealant to the threads as necessary.
5. Install a new breather element beneath the breather cover.
6. Position the wire mesh filter screen in the base of the reservoir and secure with the snap ring.
7. Install a new filter element assembly and the by-pass tube following the removal procedure in reverse.
8. If the top cover retaining bolt seals were damaged during disassembly, replace the bolts or alternatively add thread sealant to the threads as necessary.
9. Examine the reservoir hoses for damage and renew as necessary.

## HYDRAULIC CYLINDERS - OVERHAUL

### GENERAL

For reasons of cleanliness and ease of handling, all cylinders should be removed from the unit for overhaul. However, it is strongly recommended that the gland on all cylinders be loosened prior to removal from the attaching points. In the case of loader cylinders which have a wire locking device securing the gland, removal of the wire may also be eased with the cylinder still attached to the frame.

Procedures for removing each cylinder are basically the same. Ensure the loader bucket is positioned flat on the ground or supported in such a way that subsequent cylinder removal will be safe and non-hazardous to other personnel.

Ensure all residual pressures are relieved before disconnecting hydraulic connections. Use care in the handling of cylinders. Secure cylinders with a sling during removal and installation. Dropping or mishandling can cause damage to the surface of the rod or cylinder bore.



**WARNING: DO NOT REMOVE CYLINDERS FROM THE LOADER WITHOUT FIRST PROVIDING AMPLE SUPPORT AND BLOCKING FOR STRUCTURAL MEMBERS.**

### OVERHAUL

1. Thoroughly drain the cylinder of all oil from both ports. Recap these ports and thoroughly clean the exterior so that the internal parts will not become contaminated.

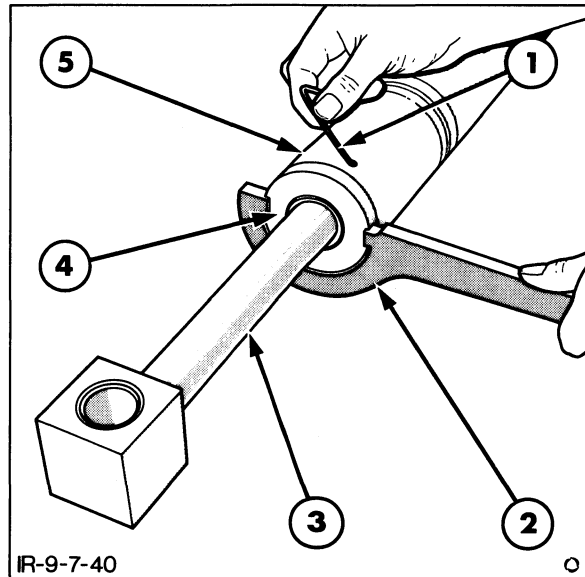
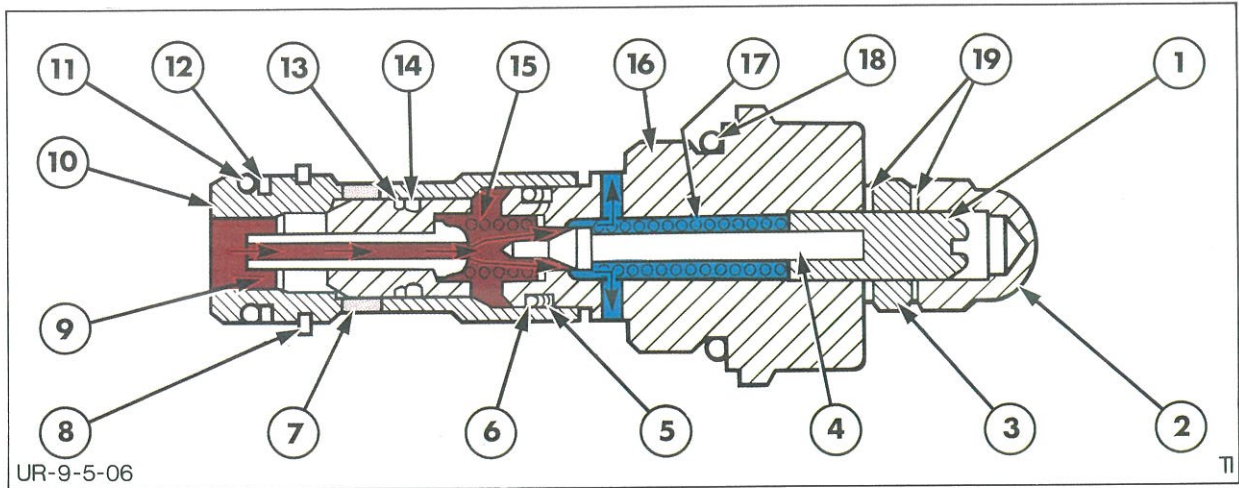

FIGURE 8-120

#### Removing Lock Wire From Cylinder

- 1 Locking wire
- 2 "C" spanner
- 3 Cylinder rod
- 4 Gland
- 5 Cylinder barrel

2. Support the cylinder and secure the base end in a vice.
3. Using the special "C" spanner applicable to the cylinder being disassembled and pulling the exposed tang of the locking wire, rotate the gland counterclockwise and remove the wire, Figure 8-120.



Pressure Oil

Exhaust Oil

FIGURE 8-134

## System Relief Valve - Schematic

- |                   |                 |
|-------------------|-----------------|
| 1 Adjusting screw | 11 'O' ring     |
| 2 Acorn nut       | 12 Back-up ring |
| 3 Locknut         | 13 Back-up ring |
| 4 Pilot valve     | 14 'O' ring     |
| 5 Back-up ring    | 15 Spring       |
| 6 'O' ring        | 16 Plug         |
| 7 Piston          | 17 Spring       |
| 8 Snap ring       | 18 'O' ring     |
| 9 Poppet          | 19 Washers      |
| 10 Sleeve         |                 |

High pressure cylinder oil enters the relief valve through the end of the hollow poppet, Figure 8-134. This oil acts against the pilot valve and the bottom end of the piston. When the pressure at the control valve inlet port exceeds the pressure exerted by the pilot valve spring, the pilot valve is unseated allowing oil to flow to the control valve return oil passage.

This flow creates a lower pressure between the piston and pilot valve and allows the poppet to move and seat against the pilot valve. This stops oil flow to the area behind the piston so that pressure in that area remains low. The higher inlet pressure forces the piston off its seat and allows the high pressure oil to flow through the oil passages to sump.

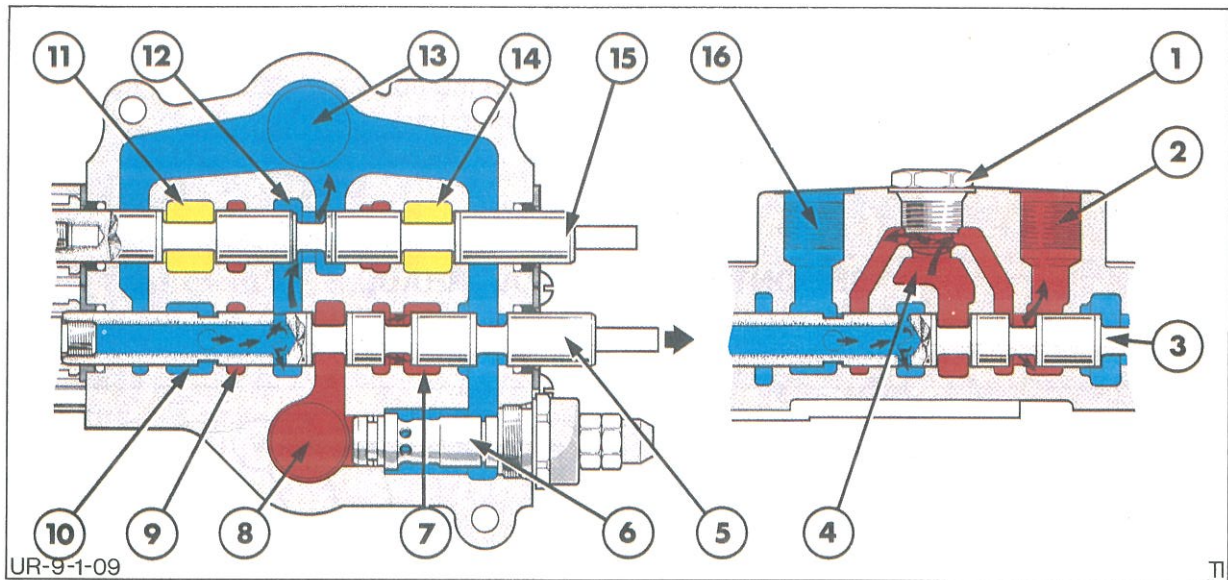

Pressure Oil



Return Oil



Trapped Oil

FIGURE 8-145

## Bucket Spool - Dump Position

- |                    |                |
|--------------------|----------------|
| 1 Check valve      | 7 Piston port  |
| 2 Piston port      | 8 Pump oil     |
| 3 Lift spool       | 13 Return port |
| 4 Pressure gallery | 14 Piston port |
| 5 Bucket spool     | 15 Lift spool  |
| 6 Relief valve     | 16 Rod port    |

**Bucket Spool - "Dump" Position**

Figure 8-145 illustrates oil flow through the control valve with the lift spool positioned to direct oil to the piston end of the bucket cylinder. Oil entering the control valve at the inlet port is directed to the bucket check valve.

When sufficient pressure builds within the control valve, the check valve is unseated and oil is delivered to the high pressure ports. The positioning of the bucket spool allows oil to

flow from the piston end high pressure port only to the piston end of the bucket cylinder. Return oil is delivered from the rod end port through the holes and passage of the bucket spool and back to sump.

5. Attach the clapper, Figure 8-154, to the positioner stud, as follows:
  - a. Insert the allen head shouldered screw through the clapper.
  - b. Apply Loctite sealant to the screw threads.
  - c. Thread the screw fully into the positioner stud and tighten to 10 ft. lbs.
6. Reinstall the electromagnet, Figure 8-154, into the tube and retain in position with the plate and retaining screw.
7. Install the tube assembly over the centering spring end of the spool and retain in position using the retaining screws, tighten the screws to 2 ft. lbs.
8. Install a new O ring seal and wiper seal on the eye end of the spool and secure in position with the seal retainer, tighten the retaining screws.
4. Insert the detent spring and center ball into the detent plunger.
5. Apply grease to the radial balls.
6. Depress the center ball with a pin punch and install the 3 radial balls into the holes in the detent plunger.
7. With the center ball still held depressed, slide the detent sleeve over the punch and detent plunger, then release the center ball.
8. Slide the spring sleeve over the spool assembly and secure it and the seal retainer to the valve body.
9. Install the retainer ring and snap ring on the outside of the detent sleeve.
10. Install the plug and snap ring into the end of the detent sleeve.
11. Install the O ring and wiper seal on the front side of the left spool and secure the seal retainer using the 2 screws.

#### **LIFT SPOOL - INSTALLATION**

1. Install the O ring, Figure 8-154, wiper seal and seal retainer onto the spring end of the spool.
2. Install the centering spring and spring collars using the detent plunger to secure them in position. Apply Loctite sealant to the plunger threads and torque the plunger to 4 ft. lbs. (5.4 N·m).
3. Slide the spool into the spool bore. Be sure that the O ring and wiper seal are properly seated.

#### **SYSTEM PRESSURE RELIEF VALVE - INSTALLATION**

1. Install new O rings and backup rings as shown in Figure 8-152. Inspect valve components for damage and replace all worn or damaged parts.
2. Install the system relief valve assembly in the valve body. Be sure that the adjusting screw, Figure 8-152, is backed out of the plug. Loosely install the locknut, washers and acorn nut.

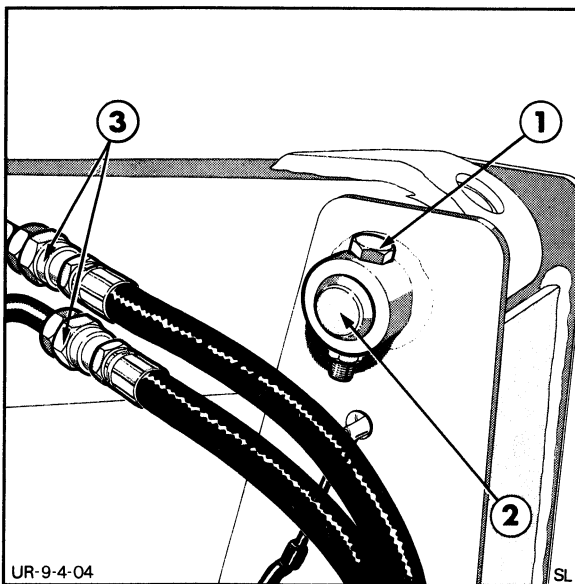

FIGURE 8-169

## Loader Lift Arms Pivot Pin

- 1 Retaining bolt
- 2 Pivot pin
- 3 Bucket cylinder hoses

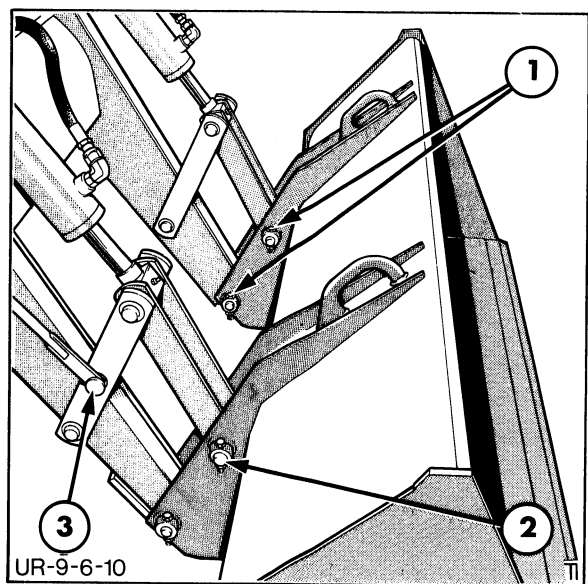

FIGURE 8-170

## Loader Bucket Link Installation

- 1 Retaining bolts
- 2 Pivot pin
- 3 Welded pin

11. Remove each loader arm pivot pin bolt and remove the pivot pin, Figure 8-169.
12. Remove the loader arm assembly to the front of the vehicle taking care to ensure that the arms remain in the balanced position.
13. Disconnect the bucket cylinder tipping and idler links. Remove the cylinder barrel pivot pins and carefully lift the cylinders from the frame.

**INSPECTION**

1. Inspect the loader arms for wear and repair as necessary.
2. Inspect the pivot pins which attach the lift cylinder to the loader frame for wear or damage and replace as necessary using the removal method described for the loader arm pivot pins.

3. Inspect the loader arm bushings where fitted, for wear or damage and replace as necessary. Damaged bushings can be replaced with suitable step plates and a driver.

**INSTALLATION**

1. Using a suitable hoist, position the loader lift arms onto the subframes and locate the left hand lift arm pivot pin in the arm and subframe.
2. Locate the retaining bolt in the pivot pin and retain in position using the nut.
3. Install the right hand pivot pin and retain in position with the retaining bolt and nut.
4. Tighten the retaining bolts to 25 ft. lbs.
5. Install the loader bucket cylinder and idler and tipping links to the lift arms.

**NOTE:** Ensure when installing the right hand bucket cylinder, that the idler link is fitted with the welded pin closest to the lift arms, Figure 8-170.

6. If removed, install the lift cylinder pivot pin in the loader subframe.

## ADJUSTMENTS

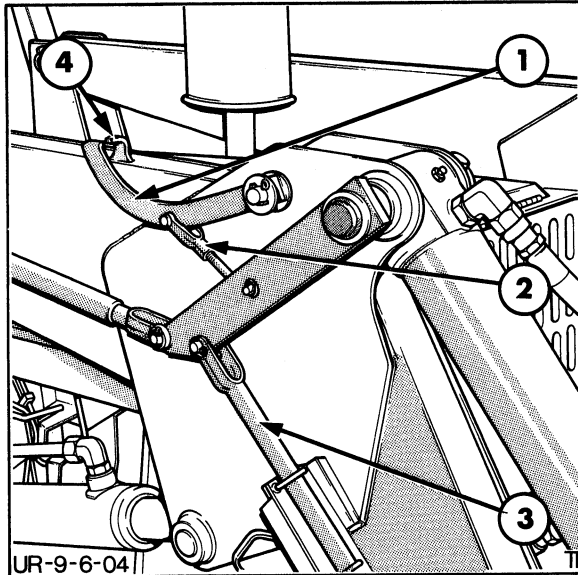

FIGURE 8-179

## Bucket Level Indicator Adjustment

- 1 Indicator
- 2 Clevis
- 3 Self-leveling linkage
- 4 Fixed pointer

**Bucket Level Indicator Adjustment**

The bucket level indicator, Figure 8-179, should be positioned so that the level indicator is aligned with the fixed reference pointer on the loader lift arm.

1. Position the tractor on a hard level surface and lower the bucket to the ground. With the bucket in this position, the level indicator should be aligned with the reference pointer.
2. If adjustment is necessary, remove the cotter pin and clevis pin and rotate the clevis.
3. Reinstall the clevis and recheck the adjustment.
4. Repeat the procedure as necessary to achieve the correct adjustment.

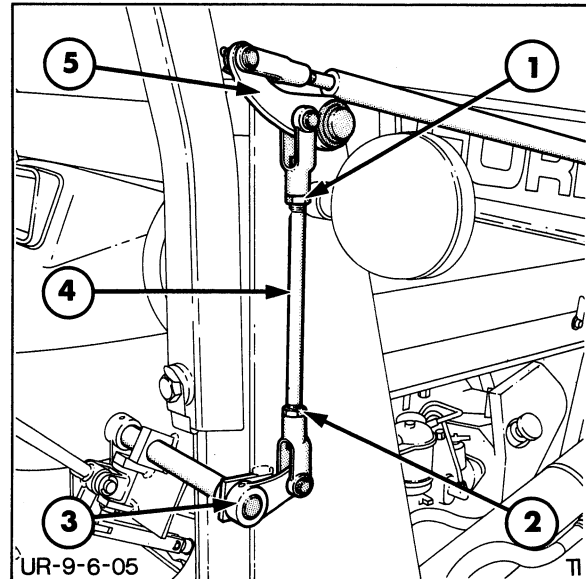

FIGURE 8-180

## Self-Leveling Linkage Adjustment

- 1 Upper locknut
- 2 Lower locknut
- 3 Rod
- 4 Lower bell crank
- 5 Upper bell crank

**Hydro-Mechanical Self-Leveling Linkage**

This system provides bucket leveling action from the carrying position to maximum height by means of a mechanical feedback linkage which actuates the bucket dump spool of the loader control valve during the lift cycle.

Adjustment for the hydro-mechanical self-leveling linkage is made through the mechanical feedback linkage located on the right hand loader post, Figure 8-180.

To adjust the linkage, proceed as follows:

1. Position the tractor on a hard level surface and lower the bucket to the ground.
2. Fully roll the bucket back.
3. Disconnect the vertical linkage rod at the lower bell crank and loosen the locknuts.
4. Adjust the vertical linkage so that the distance between the clevis pin hole center is 15.5" (395 mm). Reassemble the linkage to the bell cranks.

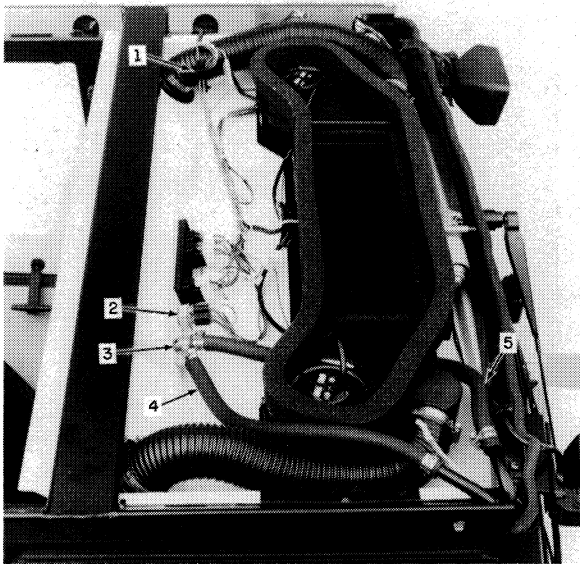

FIGURE 9-14

**Roof Access**

- 1 Roof electrical connection
- 2 Blower switch
- 3 Heater valve
- 4 Inlet hose
- 5 Outlet hose

The heater core, blowers, windshield wiper, and electrical connections are now easily accessible, Figure 9-14.

For additional information on cab wiring, see the Electrical Section.

**INSTALLATION**

Installation of the cab roof follows the removal procedure in reverse.

- Check that the sealing strip is in place around the top of the cab frame.
- Reconnect the rotating beacon connector and windshield washer tube before installing the roof bolts.

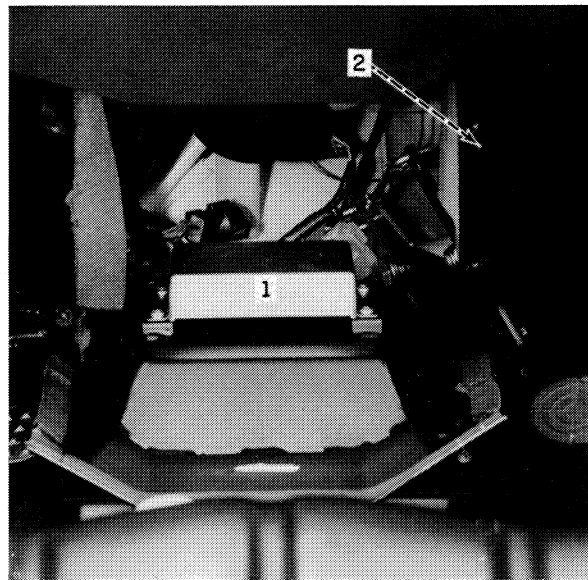

FIGURE 9-15

**Front Access Panel**

- 1 Control module
- 2 Throttle rod clamp

**CONSOLE****Removal**

1. Loosen and remove the 4 screws on either side of the console.
2. Remove the front access panel and disconnect the transmission module, Figure 9-15.
3. Loosen the throttle rod clamp and slide the upper throttle rod up out of the console, Figure 9-15.

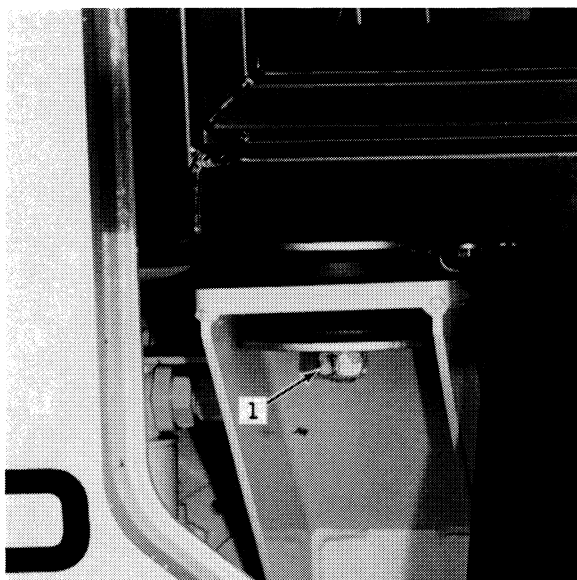

FIGURE 9-38

Front Cab Mounts

- 1 Front cab mount bolts



FIGURE 9-39

Cab Raised

- 1 Cab support

26. Loosen and remove the two front cab mount bolts, Figure 9-38.
27. With assistance or a fork lift, tip the cab up supporting it at the roof frame with a stand approximately 5' high, Figure 9-39.

**NOTE:** The cab weight goes over-center quickly, have help at the back of the cab to lower it onto the support. Not supporting the cab will cause the fenders to be damaged.

28. As shown in Figure 9-40; the rear axle top cover and transmission can be worked on and/or removed from this position, appropriately supporting the subframes and the rear axle.
29. If the cab needs to be completely removed, use a suitable lifting device and support the cab at the cab roof. Remove all four mounting bolts and lift the cab off of the tractor.

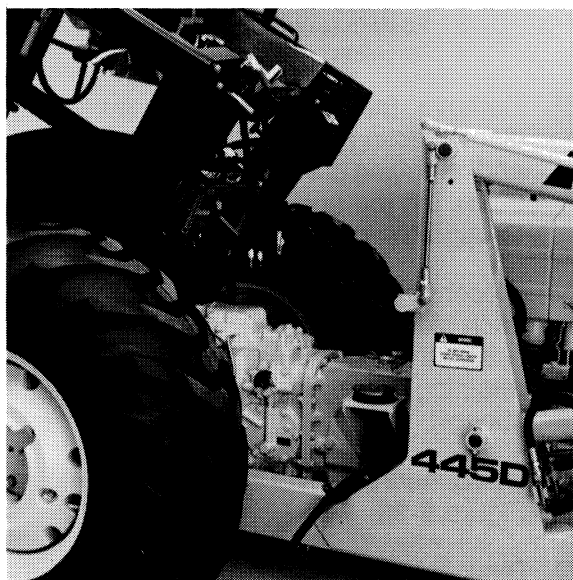

FIGURE 9-40

Access with Cab Raised



SECTION 11 - ACCESSORIES

1. Remove the left lower rear hood side cover. It is not necessary to disconnect the electrical connections.
2. Remove the upper rear screw that attaches the modulator control box to the side cover.
3. Cut the mounting tab of the relay as shown and attach the relay to the side cover using the original screw.

**NOTE: Be sure the relay prongs are pointing down so that moisture cannot enter the relay and cause damage.**

4. Connect the relay base from the wire harness to the relay.
5. Route the gray/black wire from the relay base along the side of the existing conduit on the transmission and over the left rear axle. Secure the wire with tie straps.

**MOUNTING THE BACKUP ALARM**

The next step is to mount the backup alarm. The installation will differ slightly depending upon which alarm is to be installed. (i.e. standard alarm or smart alarm).

Refer to schematic, Figure 11-12, for installation details. Use in conjunction with the written instructions.

**NOTE: Smart Alarm Installation - When installing a Smart Alarm, the appropriate connectors must be attached to the wires. Attach an eyelet with a 5/16" hole to the black wire from the alarm. Attach a male bullet connector to the red/white wire. These wires are supplied in the kit.**

1. Locate and drill two 5/16" mounting holes in the left-hand fender (crown or flat top fenders).
2. Attach the backup alarm to the fender using the bolts, washers, and the nuts included in the kit.

**NOTE: Attach the black ground wire to one mounting bolt.**

3. Connect the gray/black wire to the red/white alarm wire as shown. Use heat shrink to protect the connection.
4. Test the backup alarm for proper operation.

**NOTE: The alarm should operate at maximum volume immediately upon activation. Correct if the alarm is not operating properly.**

5. Replace all shields and return the unit to a work-ready condition.

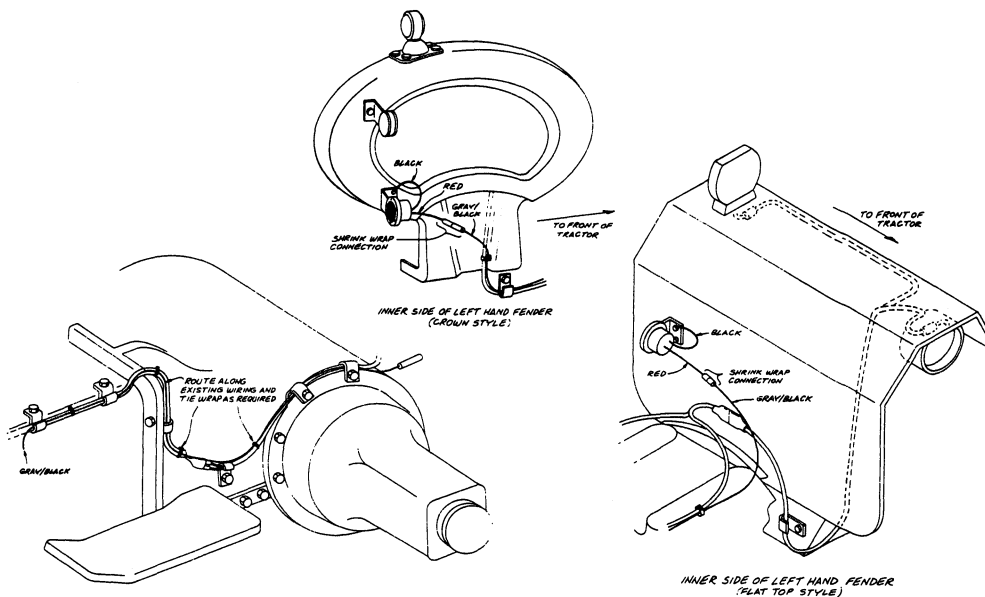

MOUNTING THE BACKUP ALARM HORN (TYPICAL INSTALLATION)

FIGURE 11-12

SECTION 11 - ACCESSORIES

REDUCTION GEAR SET

REDUCTEUR

REDUKTIONSGETRIEBE

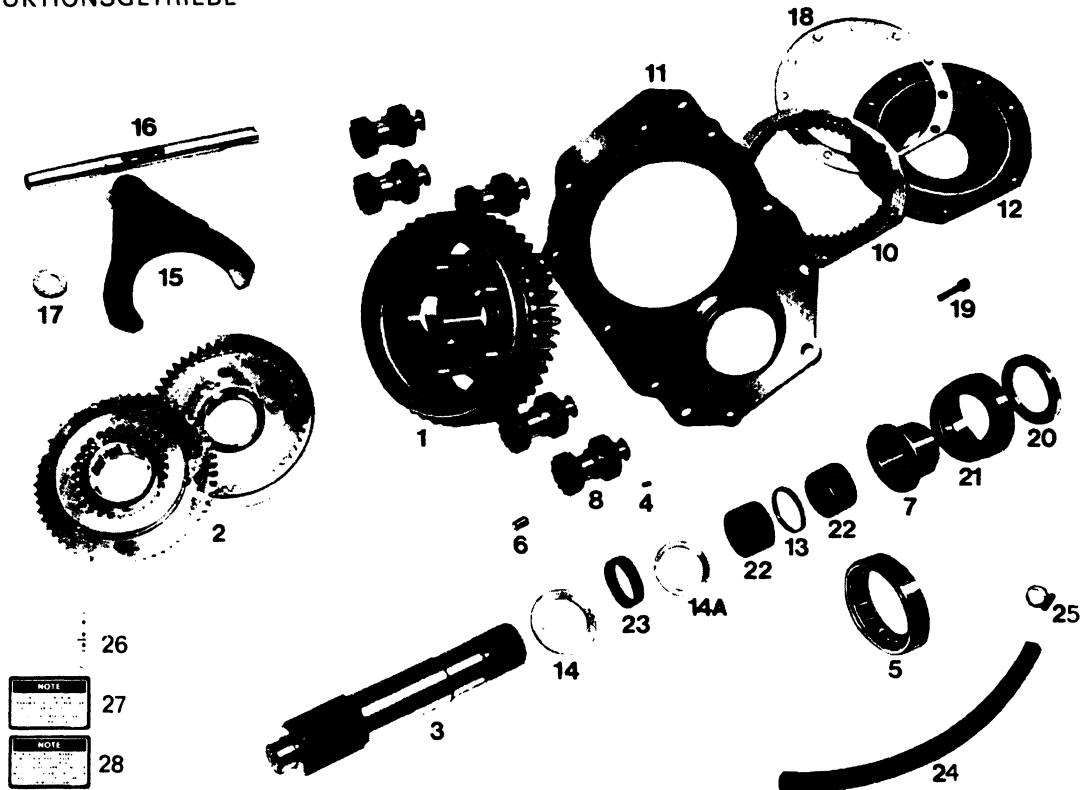

COMPLETE KIT ASSEMBLIES

KITS COMPLET

KOMPLETTE BAUGRUPPEN

Tractor Model Application Modèle du Tracteur Concerné Traktor-Modell-Anwendung	Reduction Ratio Rapport de Reduction Untersetzungsverhältnis	Part No. No. de Pièce Bestell-Nr.	Finis Code
2910-3910-4110-4610	5.7:1	FTO-70-7C373-A	1940 034
2910-3910-4110-4610	10:1	FTO-72-7E373-A	1915 787

ALL TRACTORS WITH DOUBLE REDUCTION REAR AXLE.

SECTION 11 - ACCESSORIES

**Ford 4100 and 4600 models only:**

- b. Remove the oil exhaust tube from the flow control valve plate. Cut the exhaust tube to a length of 31 mm from the retaining nut, swivel the tube through 90 degrees, and reinstall. Attach the flexible tube (24) and secure with clamp (25).

**IMPORTANT:** Ensure the clamp is positioned with the screw between the tube and the top wall of the rear axle center housing. Route the flexible hose over the output shaft retainer to the left-hand side.

- c. Re-install the hydraulic lift cover assembly.
- 3. Remove the transmission top cover assembly.
- 4. Remove the rear retainer plate from the transmission housing.

**Ford 5610, 6610, 6710, 7610, 7710, and 8210 models only:**

Remove the PTO drive shaft, bearing, and circlips from the rear retainer plate.

- 5. Remove the output shaft and gear assembly.
- 6. Remove the countershaft rear bearing.
- 7. Remove the high/low detent plunger, spring, and ball.
- 8. Remove the high/low rail, fork, and coupler.



**CAUTION: ENSURE THE SAFETY START SWITCH COMPONENTS DO NOT DROP INTO THE TRANSMISSION HOUSING.**

- 9. Remove and discard the high/low gear shaft lever washer located within the transmission top cover stop plate.

Enlarge the high/low slot in the stop plate by reworking to the dimensions shown in Figure 11-30.

**NOTE:** This action ensures sufficient movement of the high/low shift lever to facilitate engagement of high, neutral, low, and creep gears.

Model	Part No.	Description	Finis Code
Ford 2910, 3910, 4110 and 4610  Ford 5610 and 6610 With Separate sumps	C5NN-7N047-A	Cone and Roller Assy. –  Output Shaft to  Main shaft	1804636
Ford 5610, 6610, 6710 7610, 7710 and 8210 with common sump	D0NN-7N047-A	Cone and Roller Assy. – Output shaft to Main shaft	1823619
All Models	E75-GE-9	Bearing–P.T.O. Drive Countershaft	1800755
Ford 2910, 3910, 4110 and 4610 Ford 5610 and 6610 With Separate Front and Rear Transmission Sumps	E62-GE-9	Seal Assy. – P.T.O  Countershaft	1717077
All Models	957E-790	Snap Ring – P.T.O. Countershaft Bearing (02)	1801973
All Models	D9NN-7086-AA	Gasket – Output Shaft Bearing Retainer	3919056

**IMPORTANT:** To ensure greatest reliability always install new parts.

## BRUSH GUARD KIT 9803093 FOR TRACTOR-LOADER W/CANOPY

**IMPORTANT:** If the canopy was installed prior to the brush guard kit being installed, loosen the canopy mounting bolts on the ROPS post and canopy mounting brackets.

1. Drill four 3/8" holes (2 each side) as detailed in Figure 11-34. Install the canopy mounting bracket (1), Figure 11-34, with the bracket facing forward.

**NOTE:** The center hole of the mounting bracket is off center. The bracket is stamped "THIS SIDE UP". Be sure the stamped side is mounted towards the roof of the canopy.

2. Secure the canopy mounting brackets, using the 3/8" x 3/4" bolts and locknuts furnished. Do not tighten.

DRILL 3/8" HOLES  
ON EACH SIDE OF  
CANOPY

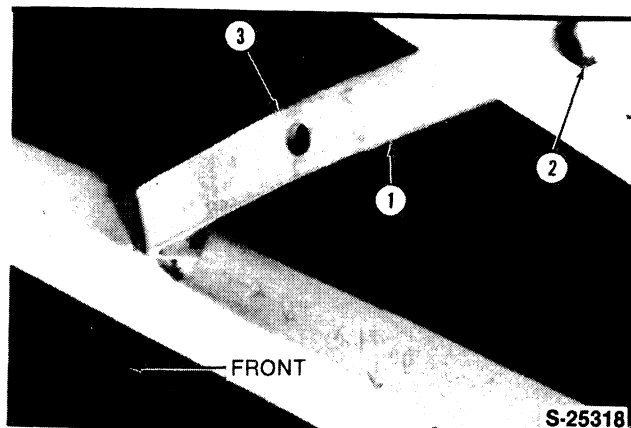
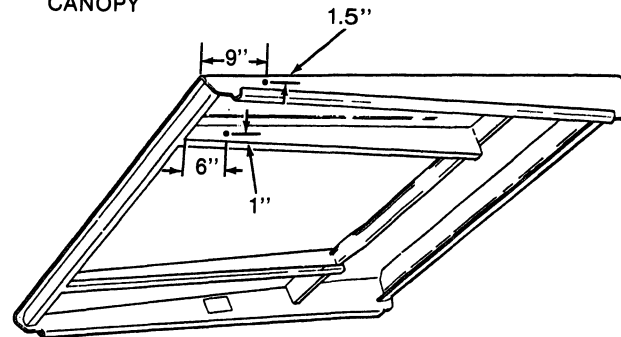

FIGURE 11-34

### Brush Guard Canopy Bracket Installation

- 1 Mounting bracket
- 2 Mounting bolt
- 3 Bracket stamped "THIS SIDE UP"

## RIGID STABILIZERS KIT # DHPN N869 A 345C, 445C, 545C

(THIS KIT WILL NOT FIT ON D-SERIES UNITS)

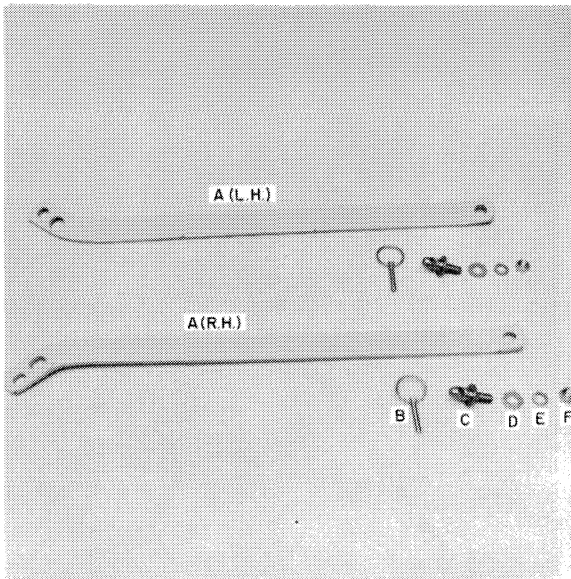

FIGURE 11-45

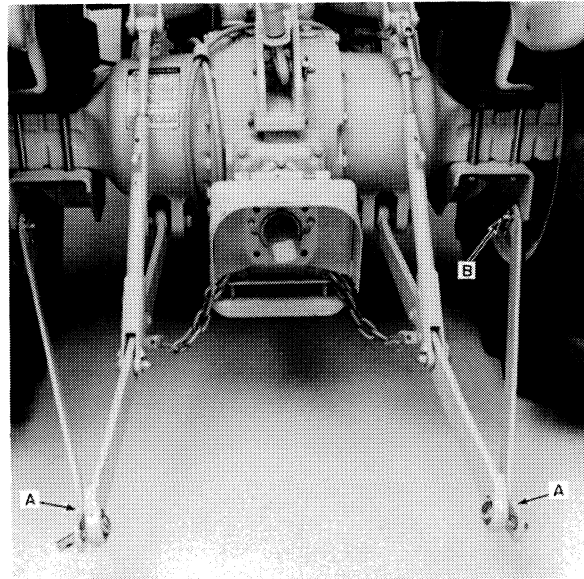

FIGURE 11-46

### Rigid Stabilizer Kit

- |                      |   |  |
|----------------------|---|--|
| A Stabilizer arms    | 2 |  |
| B Lynch pins         | 2 |  |
| C Front mounting pin | 2 |  |
| D Washer 5/8"        | 2 |  |
| E Lock washer 5/8"   | 2 |  |
| F Nut 5/8"           | 2 |  |
1. Install the front mounting pins, C, Figure 11-45, into the outside leg of the loader subframe, using the washer, lock washer, and nut, D, E, F, Figure 11-45. Assemble as show in Figure 11-46, and tighten to 155 ft. lbs.
  2. Install the single hole end of the stabilizer arm, A, Figure 11-45, on the pin, with the bend on the opposite end toward the bottom, A, Figure 11-45. Retain the arm on the mounting pin with a lynch pin, B, Figure 11-46.
  3. The double hole end of the stabilizer arm attaches on to the implement.

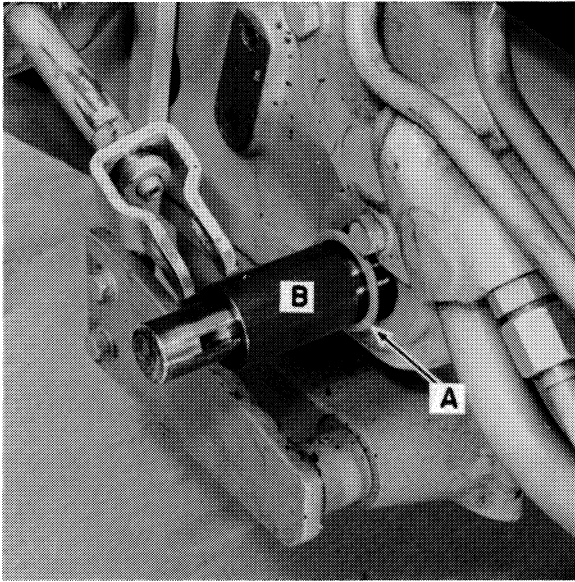

FIGURE 11-68

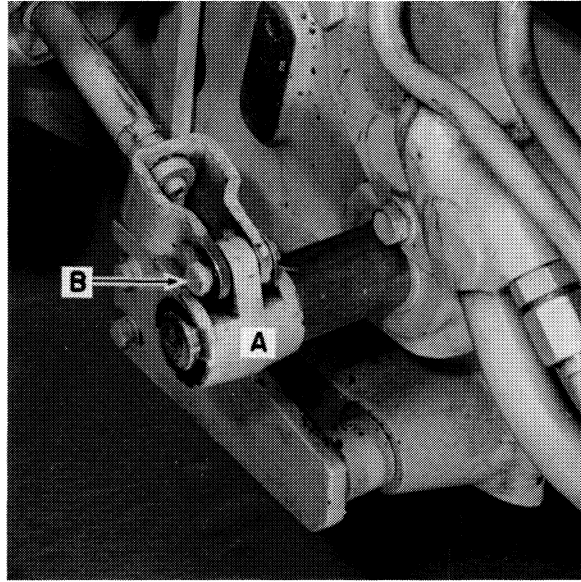

FIGURE 11-69

25. Install washer, A, Figure 11-68, that was removed at E, Figure 11-57.
26. Install new sleeve, B, Figure 11-55, onto the shaft at, B, Figure 11-68.
27. Install key and clamp lever, A, Figure 11-69, positioning it 1/16" from the end of the shaft. Tighten the clamp bolt to 50 ft. lbs.
28. At the left step plate, remove plastic push pins and fold the mat back to remove filler plate, A, Figure 11-70.
29. Cut a hole in the mat at the lines corresponding to the brake lever hole. Reinstall plastic push pins to secure mat.

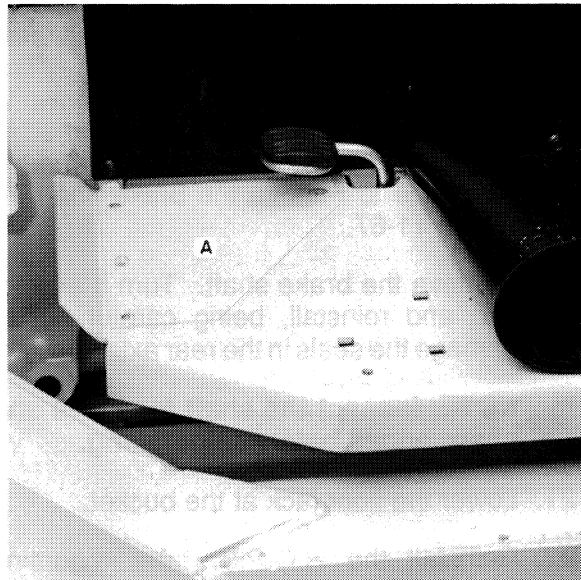

FIGURE 11-70

CLICK HERE TO **DOWNLOAD** THE COMPLETE MANUAL

- Thank you very much for reading the preview of the manual.
- You can download the complete manual from: [www.heydownloads.com](http://www.heydownloads.com) by clicking the link below



- Please note: If there is no response to CLICKING the link, please download this PDF first and then click on it.

CLICK HERE TO **DOWNLOAD** THE COMPLETE MANUAL