

# SERVICE MANUAL

**FI06.8 / FI06.8A / FI56.8 / FI56.8A**  
Motor Grader

Part number 47829043

English

January 2015



CLICK HERE TO **DOWNLOAD** THE COMPLETE MANUAL

- Thank you very much for reading the preview of the manual.
- You can download the complete manual from: [www.heydownloads.com](http://www.heydownloads.com) by clicking the link below



- Please note: If there is no response to CLICKING the link, please download this PDF first and then click on it.

CLICK HERE TO **DOWNLOAD** THE COMPLETE MANUAL

Pay attention to rotating components and do not allow to anyone to approach these areas to avoid becoming entangled.

Hands, clothing or tools getting caught in the fan blades or transmission belts, can cause amputations, violent hemorrhages and generate conditions of grave danger. For this reason avoid touching or approaching all rotating or moving parts.

A surging spray of the coolant from the radiator can cause serious burns and scalds.

Before checking the coolant level, shut-off the engine and allow machine to cool down the radiator and hoses. Slowly unscrew the cap to release any residual pressure.

If it is necessary to remove the cap while engine is hot, wear safety clothes and equipment, then loosen the cap slowly to relieve the pressure gradually.

When checking the fuel, oil and coolant levels, use lights and lamps explicitly designated as explosion proof. If these types of lamps are not use, fires or explosions may occur.

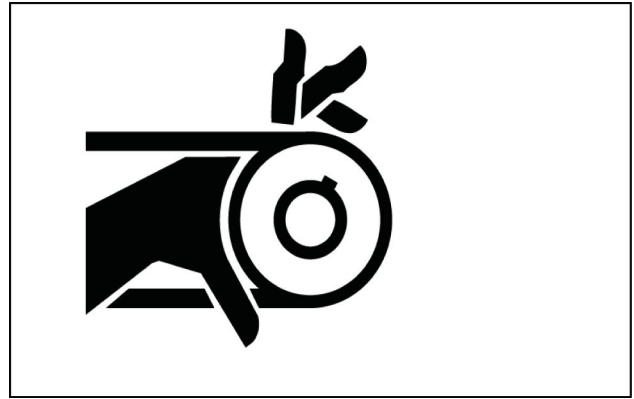

TULI12WEX2010AA 5

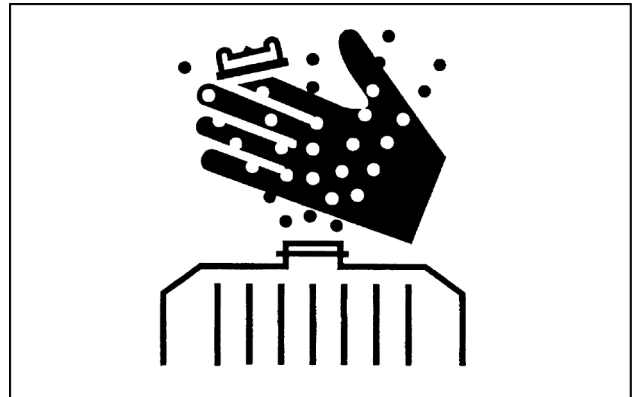

TULI12WEX2011AA 6

### Hydraulic systems

Jets of fluids under pressure can penetrate the skin causing serious injuries.

Avoid this hazard by relieving pressure before disconnecting hydraulic or other lines.

Relieve the residual pressure by moving the hydraulic control levers several times.

Tighten all connections before applying pressure.

To protect the eyes wear a facial shield or safety goggles.

Protect your hands and body from possible jets of fluids under pressure.

Swallowing hydraulic oil is a severe health hazard.



TULI12WEX2012AA 7

INTRODUCTION

**24° cone connectors (DKO) - Metallic tube connections conforming to ISO 8434-1**

Series	Tube outer diameter	Thread size	Recommended	ALFAGOMMA	FOR	PARKER	VOSS
Heavy (S)	6 mm	M14 x 1.5	22 - 28 N·m (16 - 21 lb ft)	25 - 30 N·m (18 - 22 lb ft)	14 - 16 N·m (10 - 12 lb ft)	25 - 28 N·m (18 - 21 lb ft)	24 - 26 N·m (18 - 19 lb ft)
Heavy (S)	8 mm	M16 x 1.5	30 - 40 N·m (22 - 30 lb ft)	35 - 40 N·m (26 - 30 lb ft)	25 - 28 N·m (18 - 21 lb ft)	40 - 44 N·m (30 - 32 lb ft)	38 - 42 N·m (28 - 31 lb ft)
Heavy (S)	10 mm	M18 x 1.5	35 - 50 N·m (26 - 37 lb ft)	40 - 45 N·m (30 - 33 lb ft)	27 - 30 N·m (20 - 22 lb ft)	50 - 55 N·m (37 - 41 lb ft)	48 - 53 N·m (35 - 39 lb ft)
Heavy (S)	12 mm	M20 x 1.5	45 - 60 N·m (33 - 44 lb ft)	45 - 50 N·m (33 - 37 lb ft)	43 - 54 N·m (32 - 40 lb ft)	60 - 66 N·m (44 - 49 lb ft)	57 - 63 N·m (42 - 46 lb ft)
Heavy (S)	16 mm	M24 x 1.5	65 - 80 N·m (48 - 59 lb ft)	75 - 85 N·m (55 - 63 lb ft)	60 - 75 N·m (44 - 55 lb ft)	80 - 88 N·m (59 - 65 lb ft)	81 - 89 N·m (60 - 66 lb ft)
Heavy (S)	20 mm	M30 x 2	100 - 120 N·m (74 - 89 lb ft)	105 - 120 N·m (77 - 89 lb ft)	90 - 110 N·m (66 - 81 lb ft)	120 - 132 N·m (89 - 97 lb ft)	133 - 147 N·m (98 - 108 lb ft)
Heavy (S)	25 mm	M36 x 2	140 - 170 N·m (103 - 125 lb ft)	135 - 150 N·m (100 - 111 lb ft)	125 - 145 N·m (92 - 107 lb ft)	170 - 187 N·m (125 - 138 lb ft)	181 - 200 N·m (133 - 148 lb ft)
Heavy (S)	30 mm	M42 x 2	190 - 250 N·m (140 - 184 lb ft)	205 - 230 N·m (151 - 170 lb ft)	170 - 190 N·m (125 - 140 lb ft)	250 - 275 N·m (184 - 203 lb ft)	257 - 284 N·m (190 - 209 lb ft)
Heavy (S)	38 mm	M52 x 2	260 - 350 N·m (192 - 258 lb ft)	270 - 300 N·m (199 - 221 lb ft)	200 - 245 N·m (148 - 181 lb ft)	350 - 385 N·m (258 - 284 lb ft)	380 - 420 N·m (280 - 310 lb ft)

---

## Basic instructions – Hydraulic contamination

F106.8A	WE
F106.8	WE
F156.8A	WE
F156.8	WE

Contamination in the hydraulic system is a major cause of the malfunction of hydraulic components. Contamination is any foreign material in the hydraulic oil.

Contamination can enter the hydraulic system in several ways:

- When you drain the oil or disconnect any line
- When you disassemble a component
- From normal wear of the hydraulic components
- From damaged seals or worn seals
- From a damaged component in the hydraulic system

All hydraulic systems operate with some contamination. The design of the components in this hydraulic system permits efficient operation with a small amount of contamination. An increase in this amount of contamination can cause problems in the hydraulic system.

The following list includes some of these problems:

- Cylinder rod seals that leak
- Control valve spools that do not return to neutral
- Movement of control valve spools is difficult
- Hydraulic oil that becomes too hot
- Pump gears, housing, and other parts that wear rapidly
- Relief valves or check valves held open by dirt
- Quick failure of components that have been repaired
- Slow cycle times are slow. The machine does not have enough power.

If your machine has any of these problems, check the hydraulic oil for contamination.

There are two types of contamination: microscopic and visible.

Microscopic contamination occurs when very fine particles of foreign material are suspended in the hydraulic oil. These particles are too small to see or feel. Microscopic contamination can be found by identification of the following problems or by testing in a laboratory.

Examples of problems caused by microscopic contamination:

- Cylinder rod seals that leak
- Control valve spools that do not return to neutral
- The hydraulic system has a high operating temperature

Visible contamination is foreign material that can be found by sight, touch, or odor. Visible contamination can cause a sudden failure of components.

Examples of problems caused by visible contamination:

- Particles of metal or dirt in the oil
- Air in the oil
- Dark or thick oil
- Oil with an odor of burned oil
- Water in the oil

If you find contamination, use a portable filter to clean the hydraulic system.

## Organic Acid Technology (OAT) coolant

A coolant that relies on inhibitors such as organic acid salts for corrosion and cavitation protection.

NEW HOLLAND CONSTRUCTION requires the use of a fully formulated Organic Acid Technology (OAT) -based coolant. **NEW HOLLAND AMBRA ACTIFULL™ OT EXTENDED LIFE COOLANT** is preferred. The coolant must meet the specifications outlined in the CNH material specification **MAT3624**. Use of coolant not meeting this specification is not allowed. Mixing of different coolant brands is not recommended.

**NOTICE:** OAT coolant is mandatory for all FPT engines compliant to Tier 4b emissions using Selective Catalytic Reduction (SCR). NEVER mix OAT coolant with conventional coolant and with conventional cooling system additives.

**NOTICE:** Issues as a result of failing to follow the above guidelines will not be covered under warranty.

In the case that the customer may have topped off an OAT coolant system with conventional coolant, check the OAT anti-freeze with conventional anti-freeze test strips to see if nitriles are present at a level higher than 20 PPM (parts per million).

If the nitrile level is excessive, follow the procedure below:

1. Empty the engine cooling system and drain the existing coolant into a suitable container.
2. Fill the system with clean water.
3. Start and run the engine for at least 30 minutes.

**NOTE:** Ensure to activate the heating system (if equipped) to circulate fluid through the heater core.

4. Repeat the steps from 1 to 3 twice
5. Fill the system with OAT coolant

The decal shown (CNH part number **47757330**) is located near the fill point of the cooling system whenever **NEW HOLLAND AMBRA ACTIFULL™ OT EXTENDED LIFE COOLANT** is filled at the factory. It can also be identified by its yellow color.

The optimum coolant/water concentration is 50/50. This concentration will protect the cooling system to **-37 °C (-35 °F)**.

If a premixed coolant is not available, mix the concentrate with 50 % of water.

The coolant concentration in the coolant/water mixture can be determined with a refractometer designed to measure ethylene glycol content.

Distilled water or deionized water is recommended for the use in the engine cooling systems.

DO NOT use hard water, sea water and softened sea that has been conditioned with salt. The minerals and salts present in potable water can cause corrosion and deposits resulting in shortened engine life.

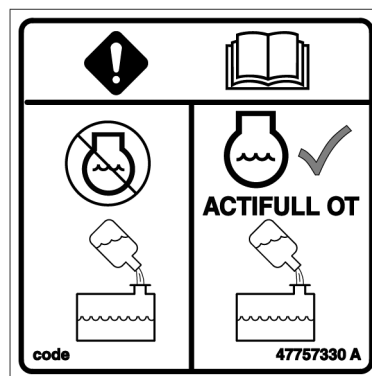

SS14H024 8

## Engine - General specification

F106.8A	WE
F106.8	WE
F156.8A	WE
F156.8	WE

Type	F106.8	F106.8A	F156.8	F156.8A
Manufacturer	FPT	FPT	FPT	FPT
Name	NEF 6Cyl 115 kW 4Valve TAA	NEF 6Cyl 115 kW 4Valve TAA	NEF 6Cyl 142 kW 4Valve TAA	NEF 6Cyl 142 kW 4Valve TAA
Model/Code	F4HFE6133*B003	F4HFE6133*B003	F4HFE6139*B003	F4HFE6139*B003
Turbo-charging	yes	yes	yes	yes
Cooling	Charge air/water	Charge air/water	Charge air/water	Charge air/water
Charge air cooling	Turbocharged	Turbocharged	Turbocharged	Turbocharged
Injection	Common rail	Common rail	Common rail	Common rail
Cylinder	6	6	6	6
Displacement	<b>6700 cm<sup>3</sup> (409 in<sup>3</sup>)</b>	<b>6700 cm<sup>3</sup> (409 in<sup>3</sup>)</b>	<b>6700 cm<sup>3</sup> (409 in<sup>3</sup>)</b>	<b>6700 cm<sup>3</sup> (409 in<sup>3</sup>)</b>
Power output	<b>115 kW (156 Hp)</b>	<b>115 kW (156 Hp)</b>	<b>142 kW (193 Hp)</b>	<b>142 kW (193 Hp)</b>
Torque	<b>725 N·m (535 lb ft) / 1400 RPM</b>	<b>725 N·m (535 lb ft) / 1400 RPM</b>	<b>850 N·m (627 lb ft) / 1400 RPM</b>	<b>850 N·m (627 lb ft) / 1400 RPM</b>
Nominal speed	<b>2100 RPM</b>	<b>2100 RPM</b>	<b>2100 RPM</b>	<b>2100 RPM</b>

# Index

---

## Engine - 10

### Engine and crankcase - 001

Engine - Complete (*) .....	13
Engine - General specification (*) .....	3
Engine - Install (*) .....	9
Engine - Remove (*) .....	4
Engine support and mounts - Install (*) .....	15
Engine support and mounts - Remove (*) .....	14

(\*) See content for specific models

- Fluid Temperature Sensor in Supply Module
  - A temperature sensor monitors the fluid temperature at the inlet of the main filter in the supply module.
- Fluid Pressure in Supply Module **(6)**
  - A pressure sensor monitors the fluid pressure delivered to the dosing module.
- Temperature Sensor – DOC upstream **(14)**. A Temperature Sensor is installed upstream of the Diesel Oxidation Catalyst (DOC) to monitor exhaust temperature. To assure an efficient operating of the Diesel Oxidation Catalyst (DOC), the exhaust temperature needs to be within a specific range. A too low temperature restricts the Diesel Oxidation Catalyst (DOC) function. The Diesel Oxidation Catalyst (DOC) will be damaged if the temperature exceeds a critical level.
- Temperature Sensor – SCR upstream **(16)**. A Temperature Sensor is installed upstream of the Selective Catalytic Reduction (SCR) to monitor exhaust temperature after the Diesel Oxidation Catalyst (DOC). To assure an efficient operating of the Selective Catalytic Reduction (SCR), the exhaust temperature needs to be within a specific range. A too low temperature restricts the Selective Catalytic Reduction (SCR) function. The Selective Catalytic Reduction (SCR) will be damaged if the temperature exceeds a critical level.
- Temperature Sensor – SCR downstream **(19)**. A Temperature Sensor is installed downstream of the Selective Catalytic Reduction (SCR) to monitor exhaust temperature. To assure an efficient operating of the Selective Catalytic Reduction (SCR), the exhaust temperature needs to be within a specific range. A too low temperature restricts the Selective Catalytic Reduction (SCR) function. The Selective Catalytic Reduction (SCR) will be damaged if the temperature exceeds a critical level.
- NOx sensor **(15)** upstream of the Diesel Oxidation Catalyst (DOC)
  - A NOx sensor is mounted upstream of the Diesel Oxidation Catalyst (DOC) to monitor the emission level before the Diesel Oxidation Catalyst (DOC).
- NOx sensor **(21)** downstream of the Selective Catalytic Reduction (SCR)
  - A NOx sensor is mounted downstream of the Selective Catalytic Reduction (SCR) to monitor the emission level after the SCR process has taken place.
- NH<sub>3</sub> sensor **(16)** downstream of the Clean Up Catalyst (CUC).
  - A NH<sub>3</sub> sensor is mounted downstream of the Clean Up Catalyst (CUC) to monitor the elimination of the residual ammonia after the SCR process has taken place.  
The elimination of the residual ammonia is electronically controlled by a specific NH<sub>3</sub> controller.





## **Engine - 10**

### **Engine lubrication system - 304**

**F106.8A**  
**F106.8**  
**F156.8A**  
**F156.8**

Transmission - Powershift transmission

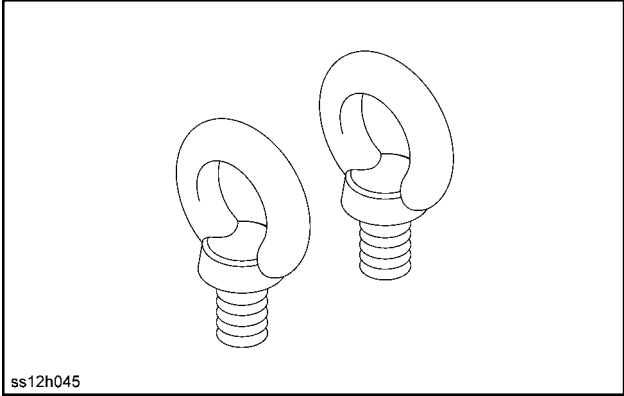
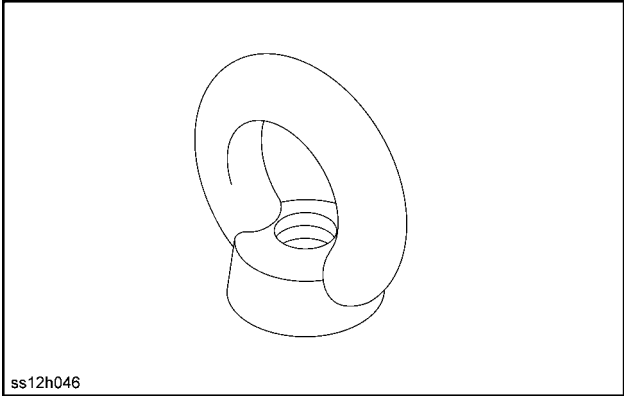
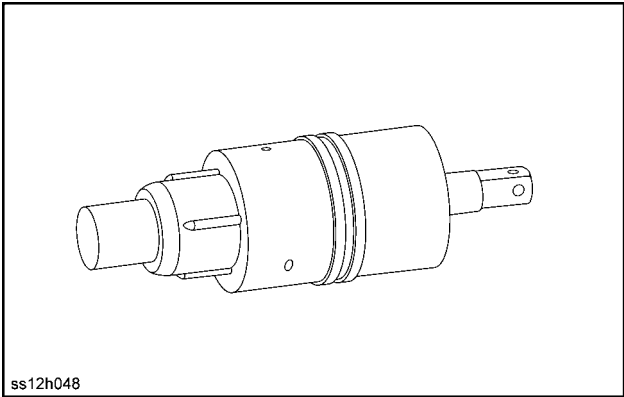
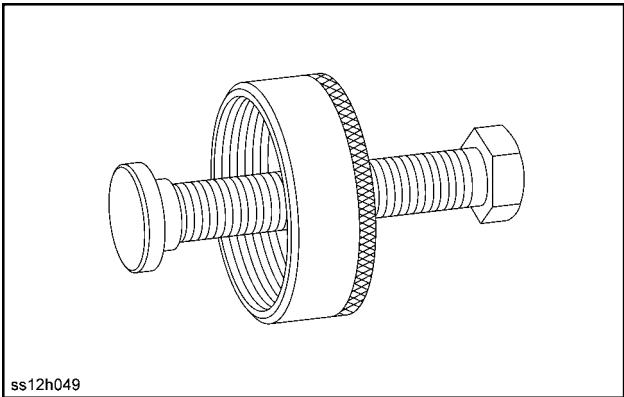
Item No.	Figure	Designation Order number
12	 <p>ss12h045</p> <p>SS12H045 12</p>	<p>Ring bolt M20 <b>0636 804 003</b></p>
13	 <p>ss12h046</p> <p>SS12H046 13</p>	<p>Ring nut M12 <b>0664 462 774</b></p>
14	 <p>ss12h048</p> <p>SS12H048 14</p>	<p>Rolling tool (suction tube) <b>5870 600 003</b></p>
15	 <p>ss12h049</p> <p>SS12H049 15</p>	<p>Puller insert <b>5870 026 100</b></p>

Transmission - Powershift transmission

<b>Pos.</b>	<b>Designation</b>	<b>Pos.</b>	<b>Designation</b>
1	Drive flange - drive through propeller shaft	9	Clutch shaft "K3"
2	Converter	10	Output flange - rear
3	Inductive sensor for engine RPM	11	Output shaft
4	Transmission pump	12	Output flange - converter side
5	Clutch shaft "KR"	13	Clutch shaft "K1"
6	Power take-off; coaxial, live	14	Converter safety valve
7	Clutch shaft "KV"	15	Clutch shaft "K4"
8	Clutch shaft "K2"		

## Transmission - Powershift transmission

Pos.	Designation	Pos.	Designation
1	Main pressure valve <b>16 bar (232.0 psi) + 2.5 bar (36.3 psi)</b>	7	Intermediate plate
2	Pressure reducing valve <b>9 bar (130.5 psi)</b>	8	Transfer plate
3	Housing	9	Pressure regulator
4	Connector (wiring harness)	10	Vibration damper
5	Cover	11	Slide valve
6	Valve block	EC	Electro-hydraulic control unit with proportional valves

## Powershift transmission - Remove

F106.8A	WE
F106.8	WE
F156.8A	WE
F156.8	WE

### **⚠ WARNING**

**Avoid injury!**

**Use Personal Protective Equipment (PPE), including protective goggles, gloves, and safety footwear. Failure to comply could result in death or serious injury.**

W1036A

### **⚠ WARNING**

**Heavy objects!**

**Lift and handle all heavy components using lifting equipment with adequate capacity. Always support units or parts with suitable slings or hooks. Make sure the work area is clear of all bystanders. Failure to comply could result in death or serious injury.**

W0398A

### **Prior operation:**

#### **Engine - Remove (10.001)**

1. Loosen the transmission outer mounting bolts (11) from the engine, and remove them.
2. Use lifting gear to lift the transmission away from the engine.

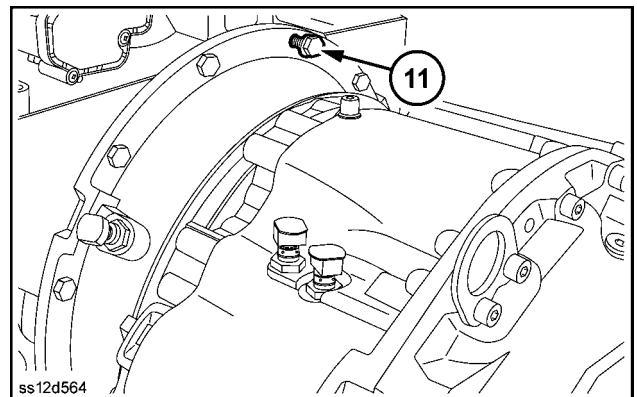

SS12D564 1

## Input shaft coupling - Assemble – Direct mounting

F106.8A	WE
F106.8	WE
F156.8A	WE
F156.8	WE

### ⚠ WARNING

**Avoid injury!**

**Use Personal Protective Equipment (PPE), including protective goggles, gloves, and safety footwear. Failure to comply could result in death or serious injury.**

W1036A

### ⚠ WARNING

**Heavy objects!**

**Lift and handle all heavy components using lifting equipment with adequate capacity. Always support units or parts with suitable slings or hooks. Make sure the work area is clear of all bystanders. Failure to comply could result in death or serious injury.**

W0398A

1. Insert the converter (1) in position using the hoist. (S) - Lifting Device **5870 204 002**

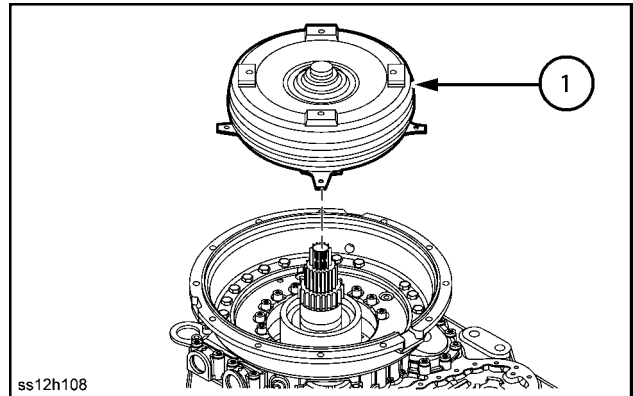

2. Fasten the diaphragm (1) using the hexagon head bolt (2).
3. Tighten the hexagon head bolts (M12/10.9x18) with **115 N·m (84.8 lb ft)**.

**NOTE:** Mount washers between converter (3) and diaphragm (1) under the hexagon head bolts.

**NOTE:** Secure the hexagon head bolts with Loctite No. 262!

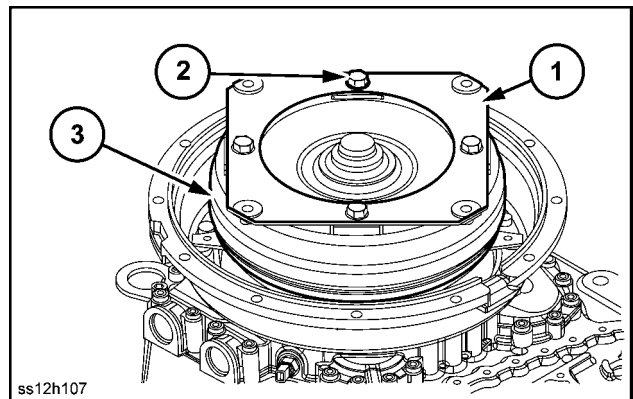

# Index

---

## Transmission - 21

### Powershift transmission - 113

Input shaft - Assemble – Power take off with WK (*)	67
Input shaft - Assemble – Power take off without WK (*)	69
Input shaft - Disassemble – Power take off (*)	65
Input shaft coupling - Assemble – Direct mounting (*)	58
Input shaft coupling - Assemble – Separate mounting (*)	61
Input shaft coupling - Disassemble – Direct mounting (*)	57
Input shaft coupling - Disassemble – Separate mounting (*)	59
Powershift transmission - Assemble – Inductive sensor, hall sensor, breather, oil fill and drain screw (*)	48
Powershift transmission - Disassemble – Inductive sensor, hall sensor, breather, oil fill and drain screw (*)	47
Powershift transmission - Dynamic description (*)	14
Powershift transmission - General specification (*)	11
Powershift transmission - Install (*)	50
Powershift transmission - Place on stand (*)	46
Powershift transmission - Remove (*)	45
Powershift transmission - Service instruction (*)	33
Powershift transmission - Service instruction – ZF Diagnostic system (*)	35
Powershift transmission - Special tools (*)	3
Transmission/Converter oil pump - Assemble (*)	53
Transmission/Converter oil pump - Disassemble (*)	51

(\*) See content for specific models

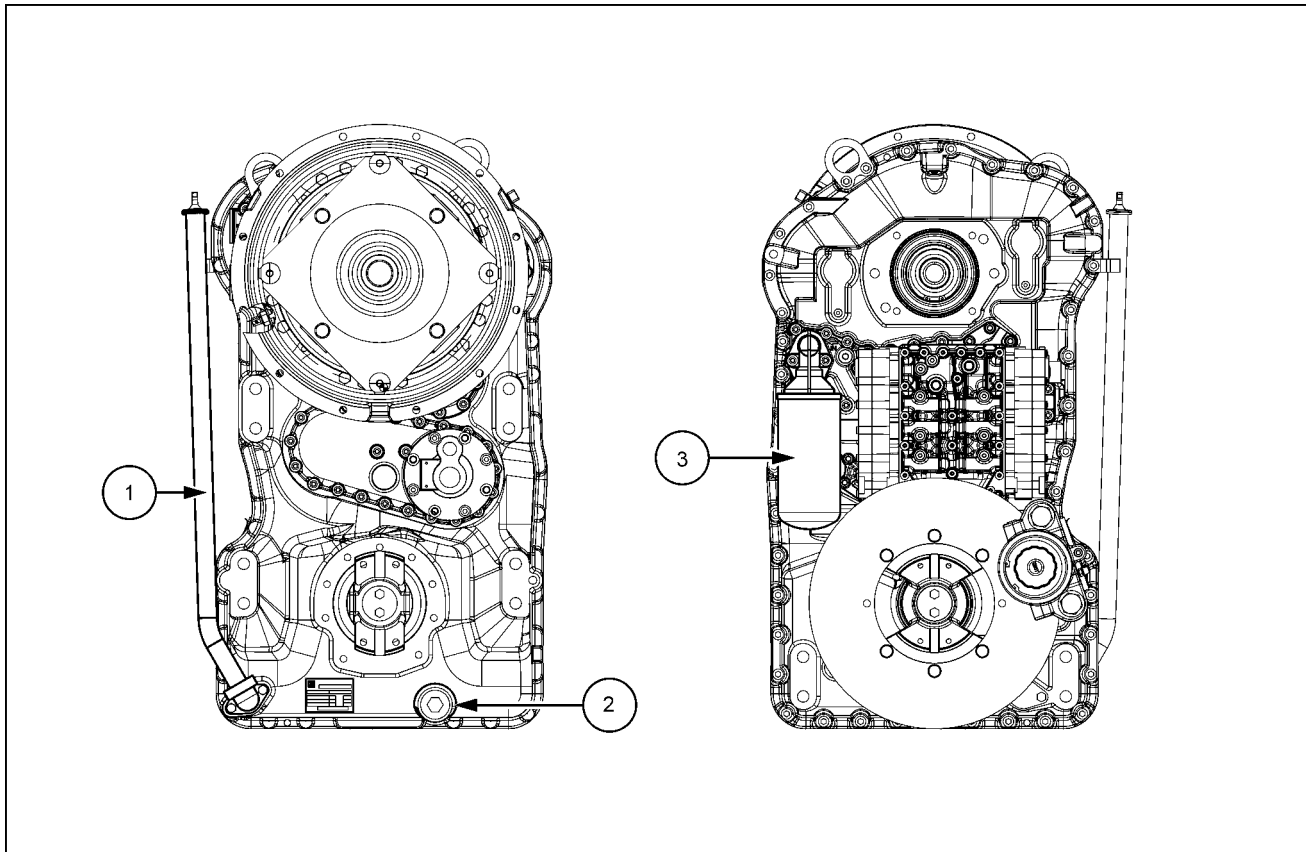

SS14J046 1

Pos.	Designation	Pos.	Designation
1	Oil-filling tube with dipstick	3	Expendable filter (ZF fine filter)
2	Oil drain screw M38x1.5		

### Oil dipstick

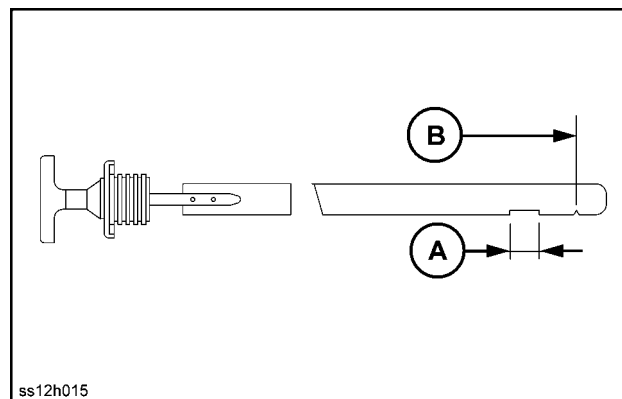

ss12h015

SS12H015 2

Pos.	Designation	Pos.	Designation
A	Range "HOT"	B	Cold min

## Output shaft - Disassemble – Output flange

F106.8A	WE
F106.8	WE
F156.8A	WE
F156.8	WE

### Prior operation:

**Powershift transmission - Place on stand (21.113).**

### Output flange on output side without parking brake

1. Remove the locking plate (1), loosen the hexagon head bolts, and remove the washer and the O-ring.

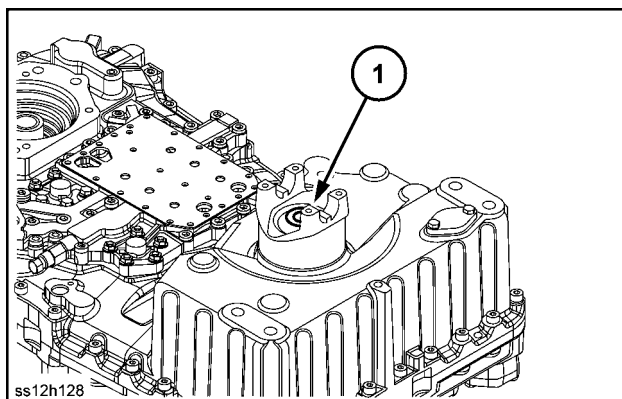

SS12H128 1

2. Pull off the output flange (1) and remove the shaft seal (2).

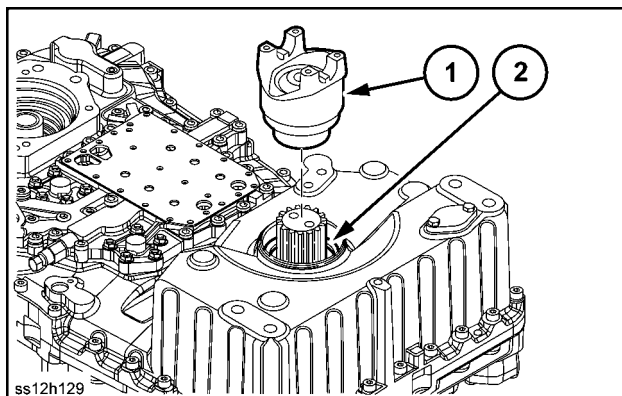

SS12H129 2

### Output flange on output side with parking brake

1. Connect the HD pump at the connection (1) and apply a pressure of about **80 bar (1160.0 psi)** to the hydraulically operated parking brake (2) until the brake disk (3) can be turned freely with the hand.

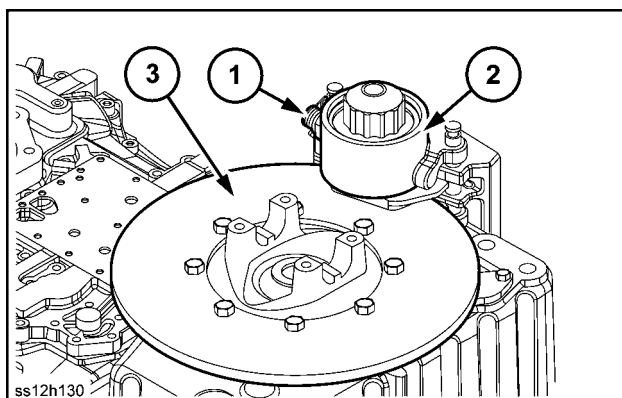

SS12H130 3

17. Fix the output shaft (1) with the circlip 120 mm (4.72 in) x 4 mm (0.16 in) (2).

**NOTE:** Ensure that the circlip is placed radially, so that the oil groove remains unobstructed.

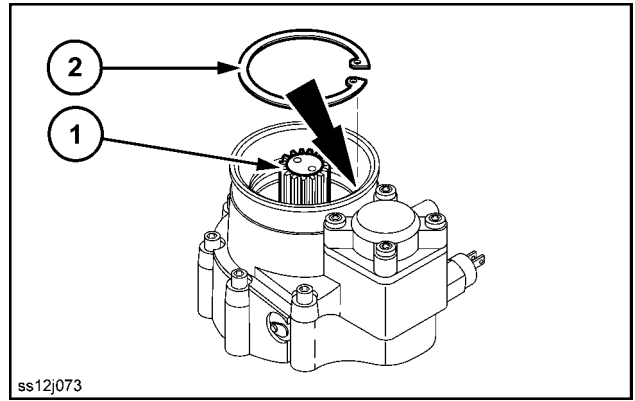

SS12J073 28

18. Standard version:  
Mount the shaft seal (1) with the sealing lip facing towards the oil gallery.  
Use the special tool (S) 5870 048 237.

**NOTE:** To obtain the exact installation position, use the specified mounting tool (S).

**NOTE:** Fill the space between sealing lip and dust lip with grease. Wipe the external diameter (rubberized) with methylated spirit.

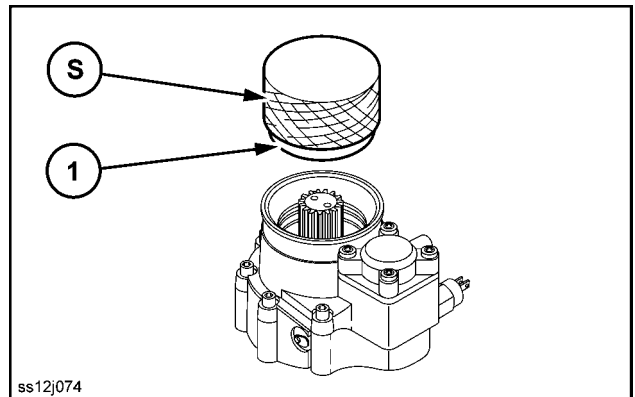

SS12J074 29

- Version with fording capacity:  
Mount the shaft seal (1) with the sealing lip facing towards the oil gallery.  
Use the special tool (S) 5870 048 300.

**NOTE:** To obtain the exact installation position, use the specified mounting tool (S).  
(Mounting tool without circlip)

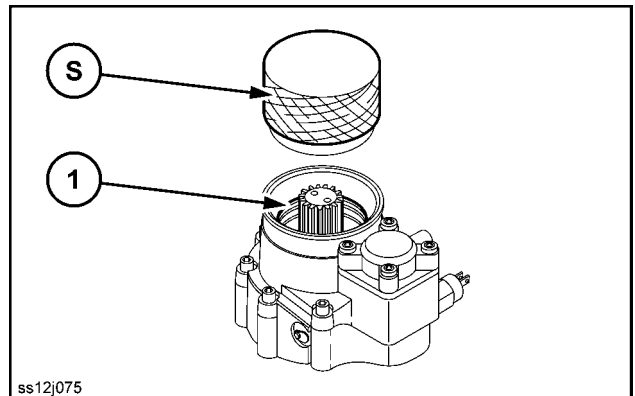

SS12J075 30

- Mount the shaft seal (1) with the sealing lip facing away from the oil gallery.  
Use special tool (S) 5870 048 300.

**NOTE:** To obtain the exact installation position, use the specified mounting tool (S).  
(Mounting tool with circlip)

**NOTE:** Fill the space between sealing lip and dust lip with grease. Wipe the external diameter (rubberized) with methylated spirit.

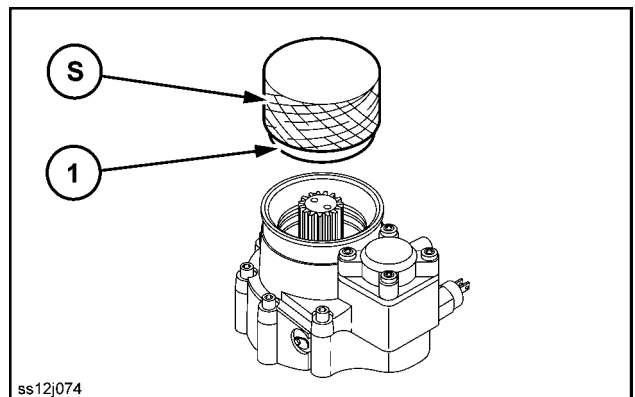

SS12J074 31

## Internal components - Disassemble – Clutch KR

F106.8A	WE
F106.8	WE
F156.8A	WE
F156.8	WE

### Prior operation:

Remove the clutches.

Refer to **Internal components - Remove – Drive shaft, output shaft and clutches (21.155)**.

1. Remove the stud bolt (1) and pry off the piston ring (2).

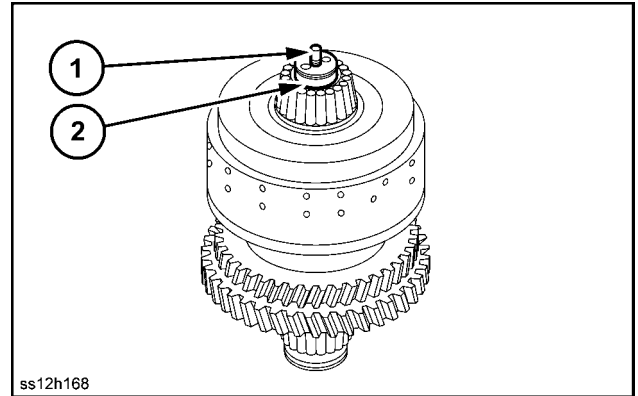

SS12H168 1

2. Pull the tapered roller bearing (inner race) away from the shaft.  
Use the special tools **5870 026 100**, **5873 001 057**, and **5873 011 011**.

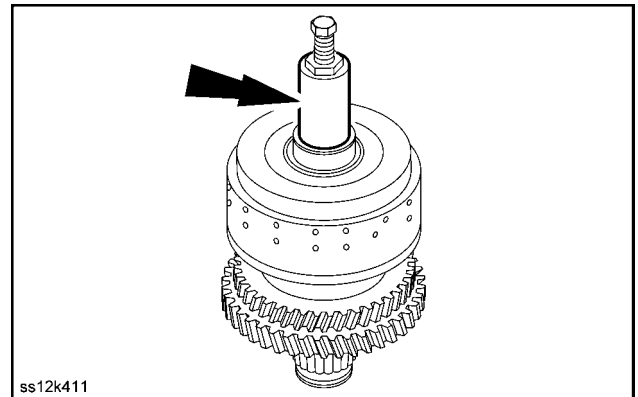

SS12K411 2

3. Pull the clutch (1) away from the shaft.

**NOTE:** For disassembly of the clutch (1), refer to Steps 10 to 15.

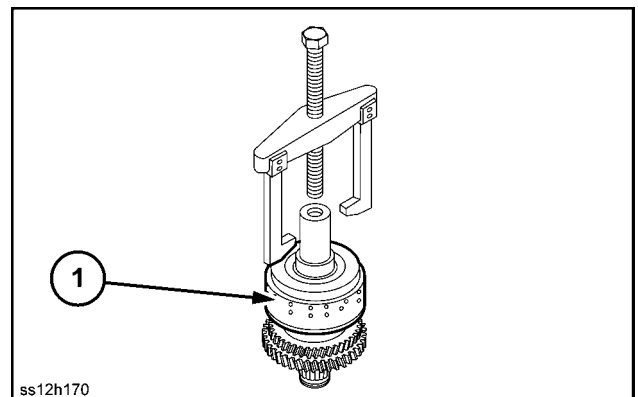

SS12H170 3

4. Take off the idler gear (1), the needle cage (2), and remove the thrust bearing (3).

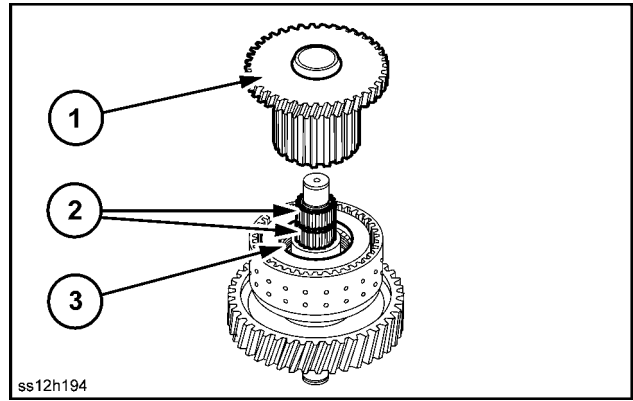

SS12H194 4

5. Pull the clutch (1) away from the shaft.

**NOTE:** For the disassembly of the clutch (1), refer to Steps 8 to 13.

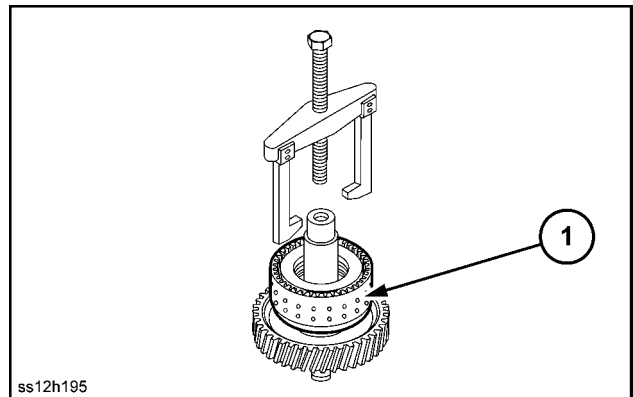

SS12H195 5

6. Turn the shaft (2) through 180° and pry off the piston ring (1).

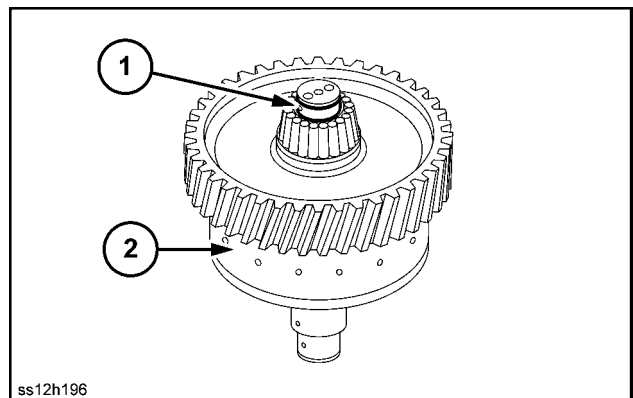

SS12H196 6

7. Pull the tapered roller bearing (inner race) away from the shaft. Use the special tools 5870 026 100, 5873 001 057, and 5873 011 011.

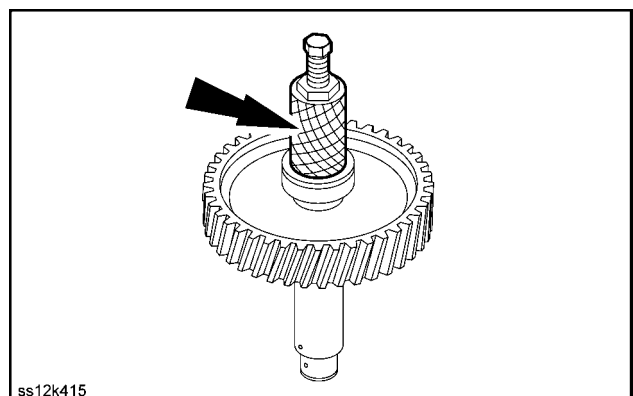

SS12K415 7

8. Insert the piston (1) in the plate support.

**NOTE:** Note the installation position!

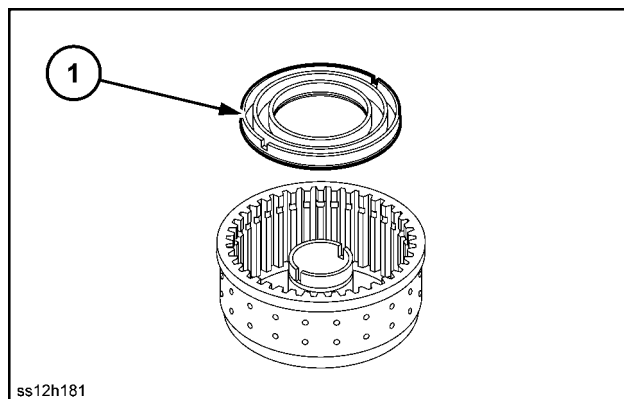

SS12H181 8

9. Using the assembling aid, insert the piston into the plate support with a hand-press.

Use the special tool (S) 5870 345 088.

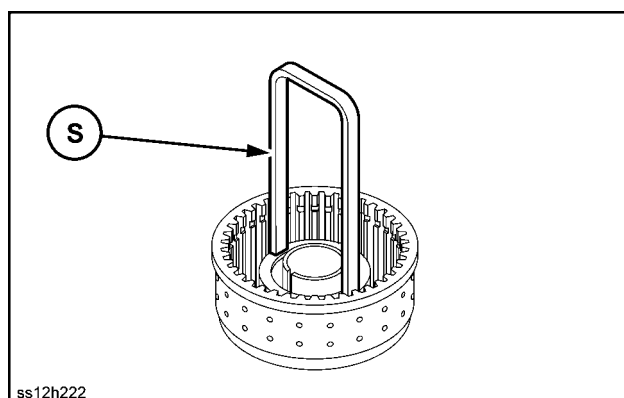

SS12H222 9

10. Mount the washer (1), the push spring (2), and the guide ring (3).

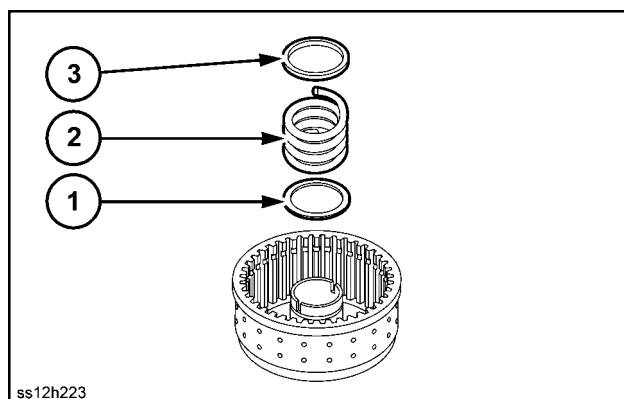

SS12H223 10

11. Pre-tension the push spring with the assembling aid and push the snap ring 64 mm (2.520 in) x 3.2 mm (0.126 in) (1) into the radial groove.

Use the special tool (S) 5870 345 088.

**NOTE:** Depending on the parts list version, different clutches (different disk coatings with the corresponding disk play) can be installed.

**NOTE:** The particular clutch or disk coating required can be found on the corresponding replacement parts list.

**NOTE:** Steps 12 and 13 show the different disk coatings.

**NOTE:** Refer to the replacement parts list for the part required.

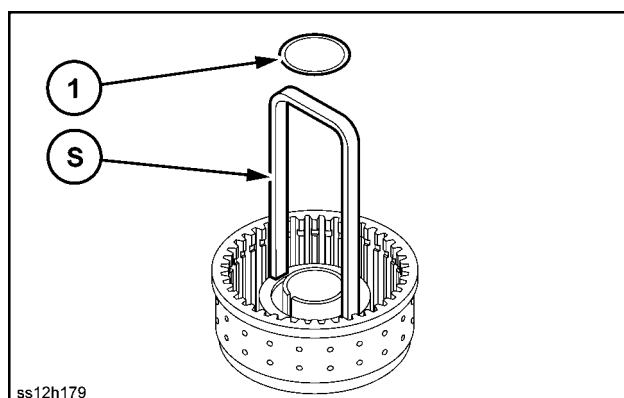

SS12H179 11

12. Heat up the inside diameter of the clutch (to about **120 °C (248.0 °F)**).

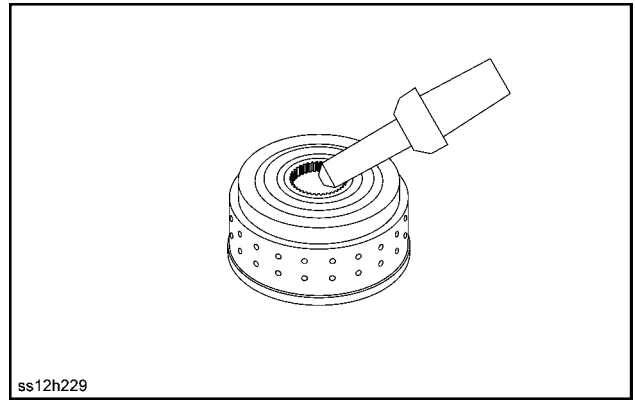

SS12H229 12

13. Mount the clutch in position.

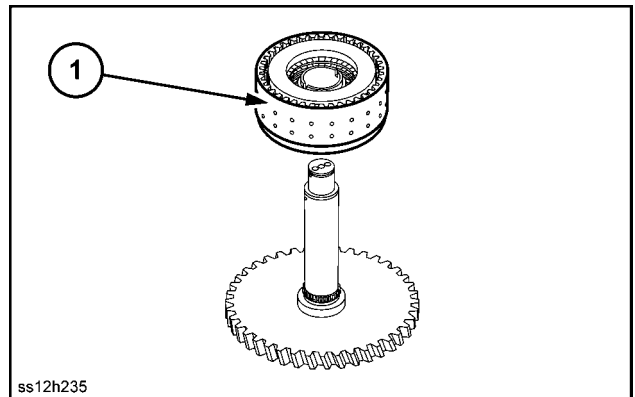

SS12H235 13

14. Mount the washer disk (1), the thrust collar (2), and the axial disk (3).

**NOTE:** Mount the washer disk (1) with the chamfered side (A) toward the thrust collar!

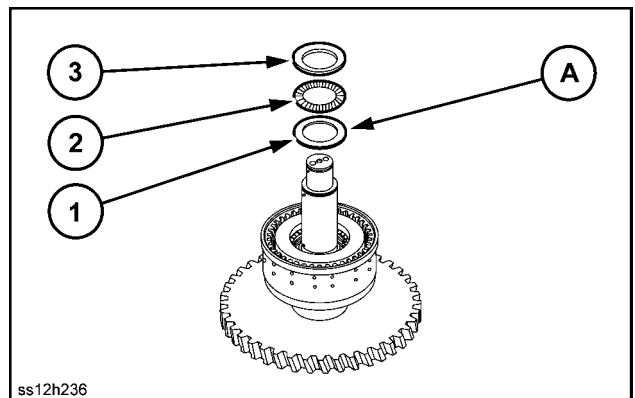

SS12H236 14

15. Mount the needle cage (1).

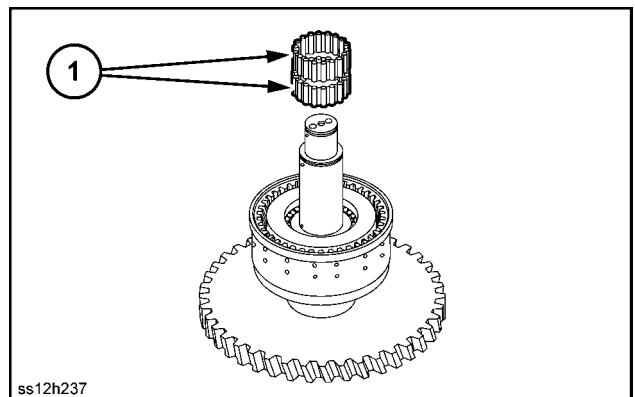

SS12H237 15

17. Mount the needle cage (1).

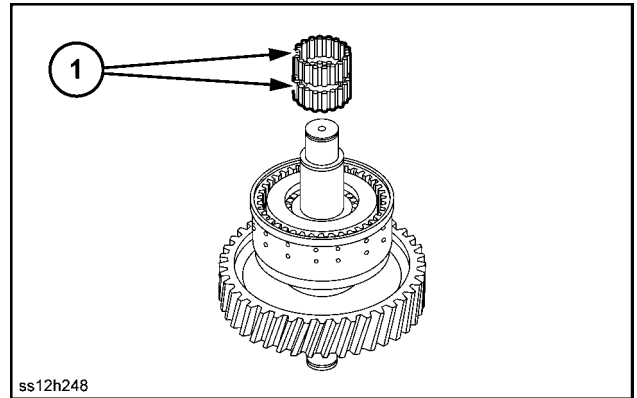

SS12H248 16

18. Mount the idler gear (1).

19. With short turns to the left and the right, mount the internal plates on the inner plate support.

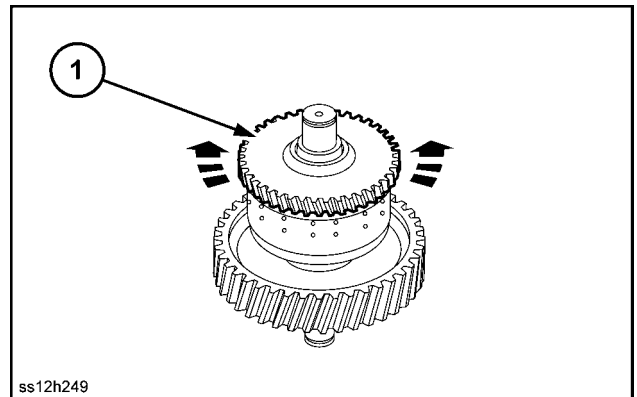

SS12H249 17

20. Mount the axial disk (1), the thrust collar (2) and the washer disk (3).

**NOTE:** Mount the washer disk (1) with chamfered side (A) facing toward the thrust collar.

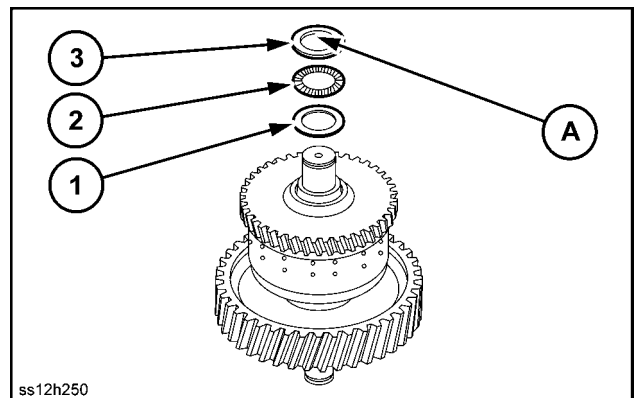

SS12H250 18

21. Press the tapered roller bearing inner race (1) into position.

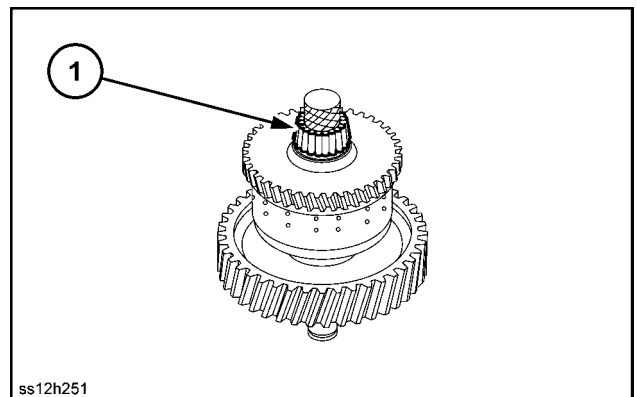

SS12H251 19

5. Mount the screw plug M38 x 1.5 (1) with new O-ring 35 mm (1.38 in) x 2 mm (0.08 in).
6. Tighten the screw plug with 140 N·m (103.3 lb ft).

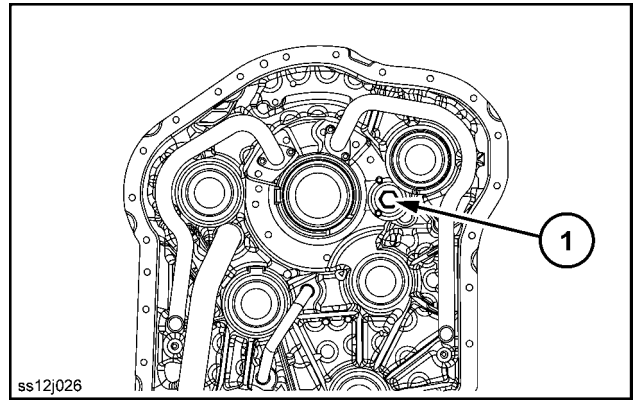

7. Use the special tool 5870 600 006.

**NOTE:** The spare parts service only supplies lubricating oil pipes (1) and (2) complete with the housing rear section. Available individually only on request! Can only be mounted using the ZF special tool (see also figure 1)!

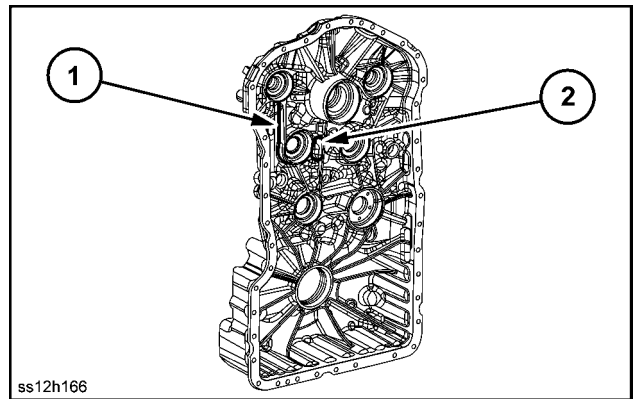

8. Insert all bearing outer races in the bearing bores in both housing sections.  
Housing front section:

- Drive (AN)
- Output (AB)
- Forward clutch (KV)
- Reverse clutch (KR)
- 1st gear clutch (K1)
- 2nd gear clutch (K2)
- 3rd gear clutch (K3)
- 4th gear clutch (K4)

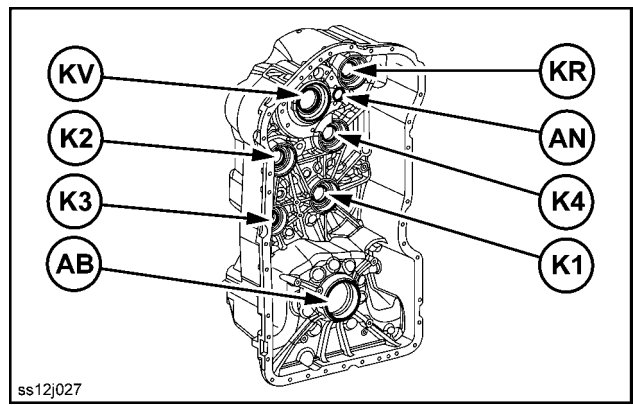

9. Housing rear section:  
See legend at Step 8.

**NOTE:** Insert all bearing outer races with mounting grease in the bearing bores.

**NOTE:** If the tapered roller bearings for the clutches, drive and output shafts are not to be replaced (not recommended by ZF), the existing pairing (bearing outer race/bearing inner race) must be retained.

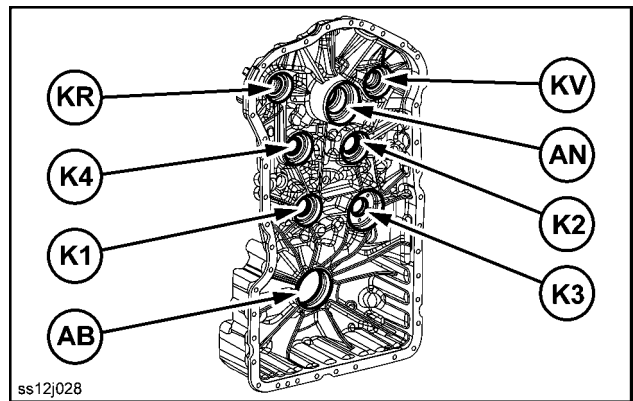

The oil driven by the impeller enters the turbine wheel, where it is turned to the direction of flow. Depending on the degree of deflection, a greater or lesser reaction torque is applied to the turbine wheel (and therefore the output shaft).

The function of the stator (reaction member) placed after the turbine wheel is to divert the oil from the turbine back to a flow direction suitable for delivery to the impeller.

Deflection of the flow causes a reaction torque to be applied to the stator.

The ratio of turbine torque to impeller torque is defined as torque conversion. This becomes greater in proportion to the difference between the impeller and turbine wheel rotational speeds.

Maximum conversion therefore occurs when the turbine wheel is stopped.

As the output speed increases, the torque conversion rate decreases. The torque converter adapts the working speed continuously and automatically to the specific torque output requirement.

If the turbine speed reaches about **80 %** of the pump speed, the conversion rate is 1.0, i.e. the turbine torque is equal to the pump torque.

From this point onwards, the converter behaves like a fluid coupling.

A stator freewheel is used to improve efficiency in the higher range; in the conversion range, it allows the torque to be supported on the housing, and it is released in the coupling range.

The stator wheel can then turn freely.

### **Converter coupling**

When the coupling is closed, the slip between impeller and turbine wheel is 'zero', and so therefore is the hydraulic loss in the converter.

The converter coupling is actuated automatically according to turbine wheel RPM.

The pressure oil ( **15.0 - 16 bar (217.5 - 232 psi)**) needed to close the coupling is delivered through a solenoid switch valve to the piston, which compresses the disk pack.

Front axle system - Powered front axle

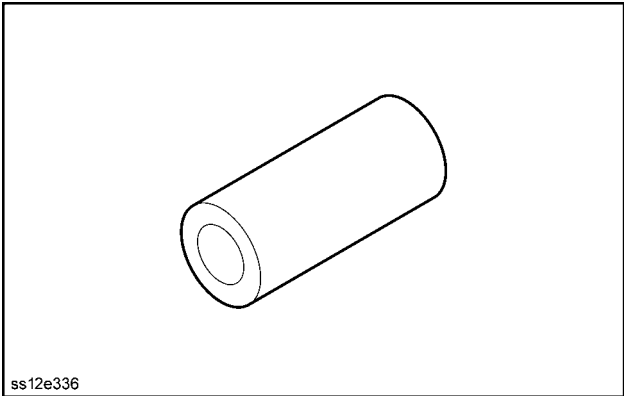
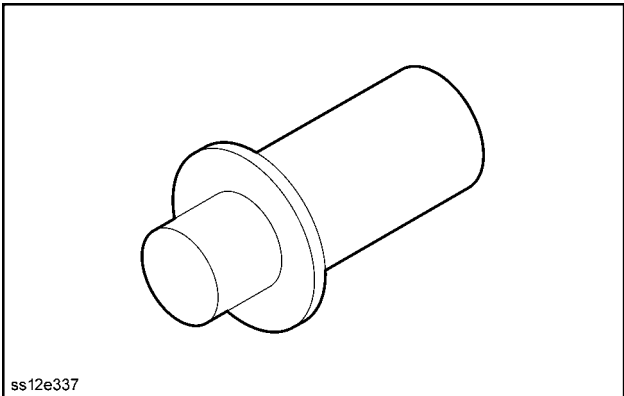
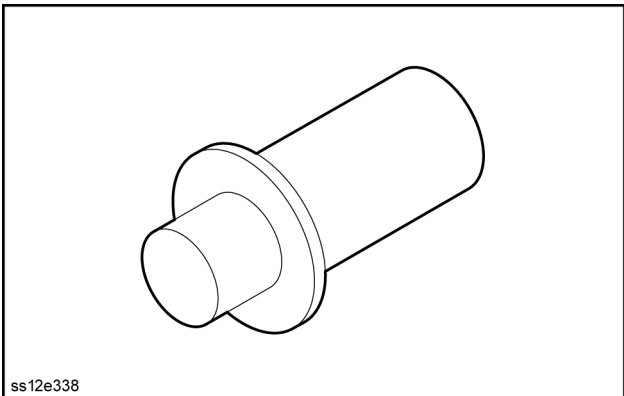
Order number	Designation	Picture
2897043	Hub removal	 <p>ss12e336</p> <p>SS12E336 1</p>
2897044	Steering cylinder joint	 <p>ss12e337</p> <p>SS12E337 2</p>
2897045	Articulated joint bearing	 <p>ss12e338</p> <p>SS12E338 3</p>

## Powered front axle - General specification

F106.8A	WE
F106.8	WE
F156.8A	WE
F156.8	WE

### All-wheel drive

The hydraulic system for the all-wheel drive consists of an adjustable axial piston pump and two radial piston motors. These main components operate in a closed circuit and form the hydrostatic drive for the front wheels.

### Technical data

Swing axle with double-pivot steering and hydraulic wheel camber adjustment.

## Powered front axle - Troubleshooting

F106.8A	WE
F106.8	WE
F156.8A	WE
F156.8	WE

Problem	Possible Cause	Correction
<b>No tractive force at front wheels</b>	No power supply to FWD control	Check the fuse, test the power supply
	Faulty On/Off switch	Check the signal from the switch; repair or replace it
	Faulty FWD control	Check the FWD switch-on function, replace the control if necessary.
	Pressure cut-off valve faulty	Check pressure cut-off Replace valve if faulty
	A high-pressure limiting valve is faulty.	Check whether high pressure builds up on one side Replace valve if faulty
	Faulty purge valve	Repair or replace it
	Feed pressure too low or absent	Check feed pressure at measuring point (MS), set the feed pressure limiting valve, or replace it.
	On/Off solenoid valve faulty	Check FWD shift pressure at measuring point (1), replace valve
	6/2 way valve faulty	Repair or replace it
	Wheel motor faulty	Repair or replace it
	Pump drive faulty (If the pump drive is faulty, i.e. the axial piston pump is no longer operated when the diesel engine is running, then the vehicle should not be driven, even with the all-wheel drive switched off.)	The pump should be replaced by a new one.
<b>Tractive force too low at front wheels</b>	Value settings IXV, IKV, IXR, and IKR	Check the value settings, and correct if necessary.
	8-stage rotary feed switch faulty	Check the signal from the switch; repair or replace it
	Pressure cut-off valve faulty	Check pressure cut-off Replace valve if faulty.
	A high-pressure limiting valve is faulty.	Check whether high pressure builds up on one side. Replace valve if faulty.
	Feed pressure too low or absent	Check feed pressure at measuring point (MS), set the feed pressure limiting valve, or replace it
<b>Tractive force too high at front wheels</b>	Refer to "tractive force too low"	
	Other possible cause: wheel motor control faulty	Check chamber pressure at measuring point (2), replace 4/2 way valve.
<b>Front wheels lock in normal straight-ahead running</b>	Inductive sensor signal for signal transmission input/output speed faulty	Check the inductive sensors using the related cable connection.
	incorrect IXV, IKV, IXR and IKR values programmed	Correct the value settings IXV, IKV, IXR, and IKR.
	Gear detection incorrect	Test the gear detection on the EDS tester, gearshift unit, and FWD control
<b>Front wheels block when shifting from 3rd – 4th forward gear or shifting from 2nd – 3rd reverse gear</b>	Air in the control line of the chamber switch-over valve to the wheel motor	Bleed the control line

22. Loosen the bolt (23) and remove it along with the nut (25)

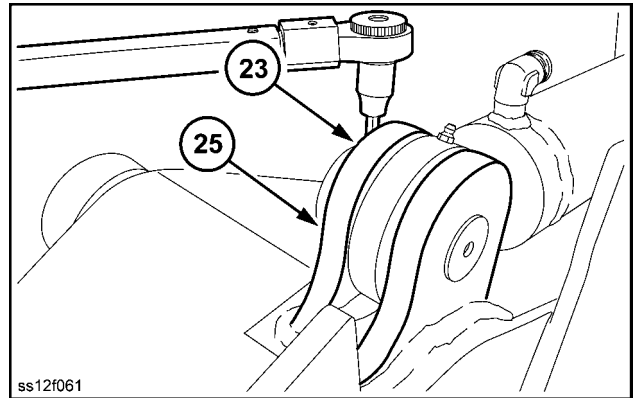

SS12F061 20

23. Knock out the bolt (24) and remove it.

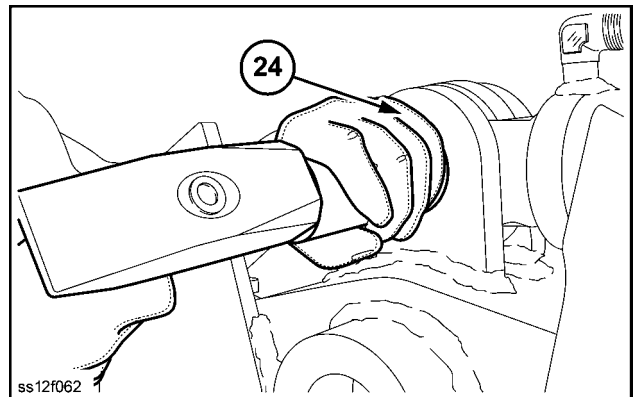

SS12F062 21

24. Remove the bolt (26) and the nut (28).

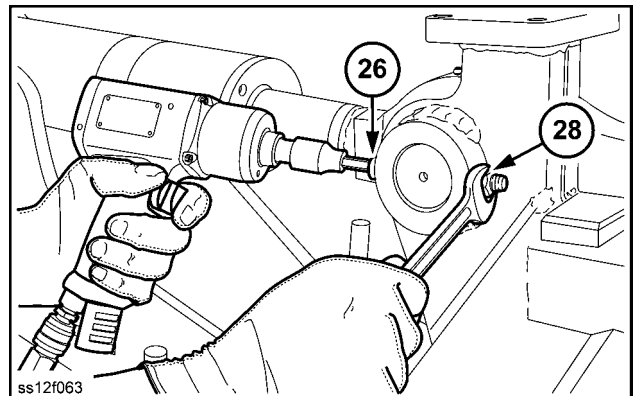

SS12F063 22

25. Knock out the bolt (27).

26. Remove the bolt (27) and the wheel lean cylinder (29).

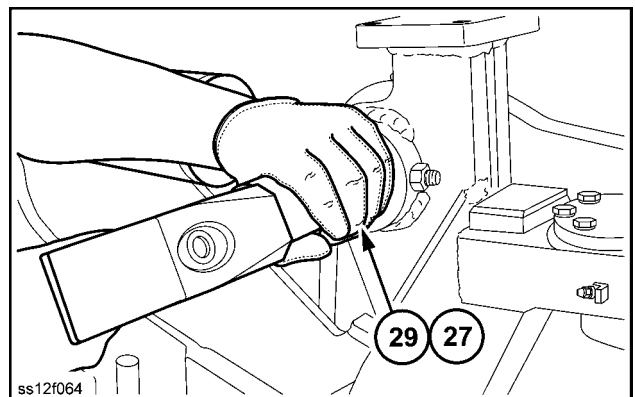

SS12F064 23

11. Mount the cover (5).

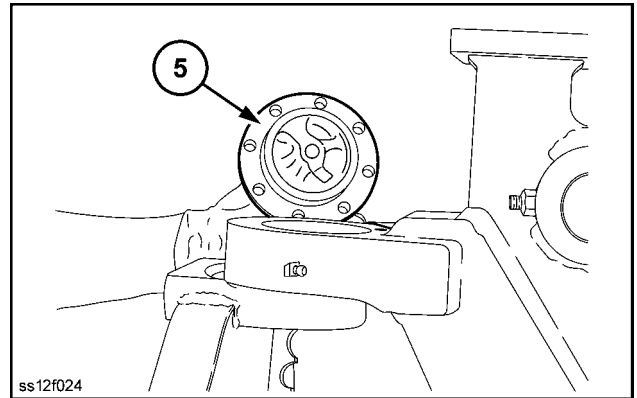

SS12F024 8

12. Insert the bolts (4) and tighten them to the specified torque.

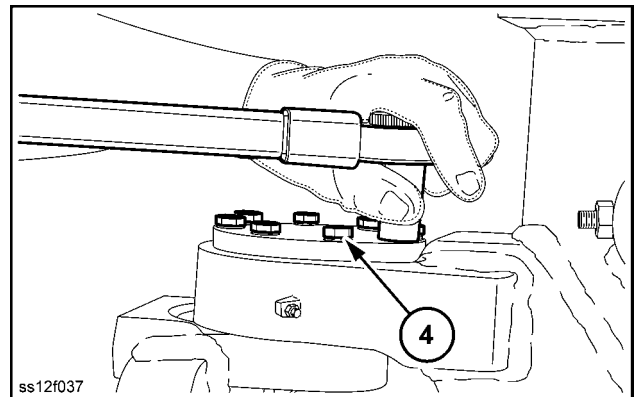

SS12F037 9

13. Insert the steering cylinder bolt and secure it with the castle nut and the cotter pin.

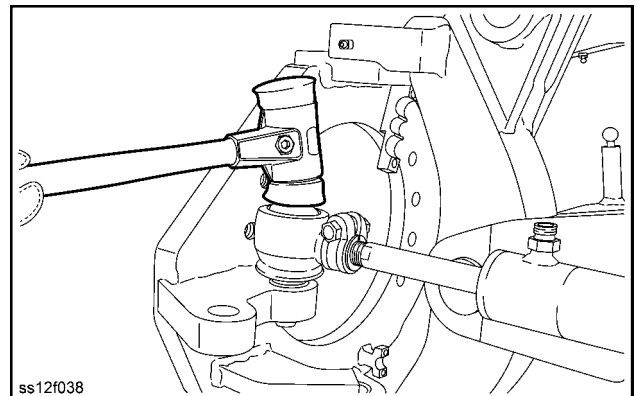

SS12F038 10

14. Insert the cylinder rod and secure it with the castle nut and the cotter pin.

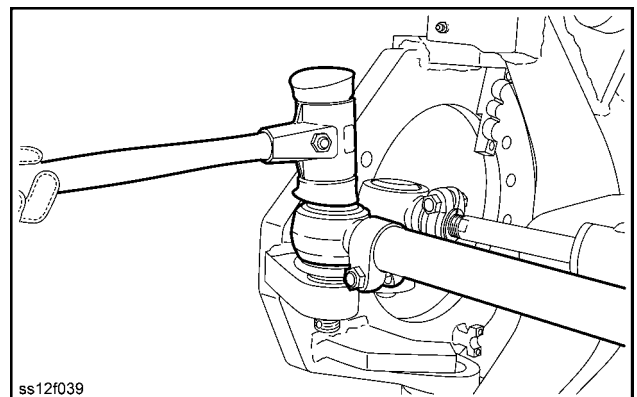

SS12F039 11

4. Pinion head height (**H**) between the bearing seat surface and the pinion shaft end.

e.g.:

**(H) = 62 mm (2.44 in)**

**NOTE:** Applies to F156.8/F156.8A

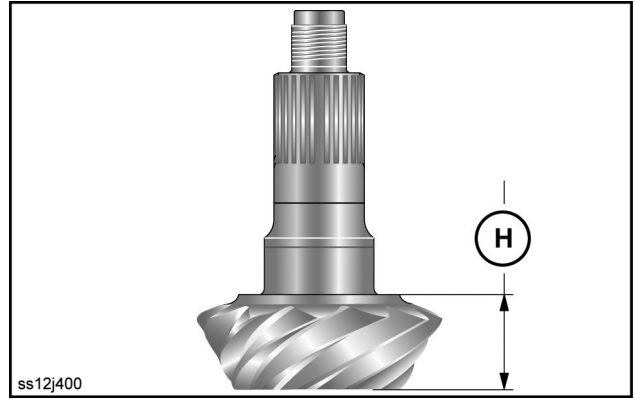

5. Pinion head height (**H**) between the bearing seat surface and the pinion shaft end.

e.g.:

**H = 82 mm (3.23 in)**

**NOTE:** Applies to F106.8/F106.8A only.

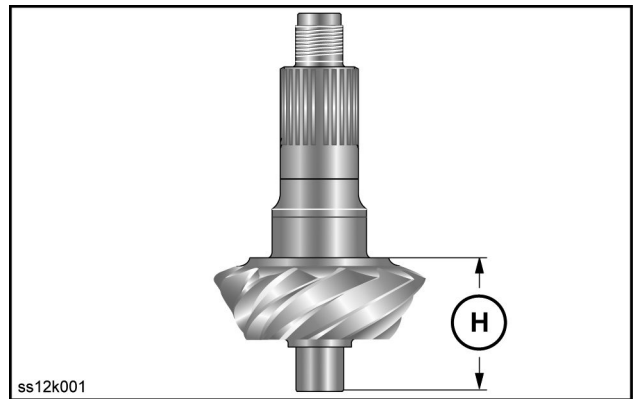

6. Measure the height of the tapered roller bearing – dimension (**D**).

**D = 37 mm (1.46 in)**

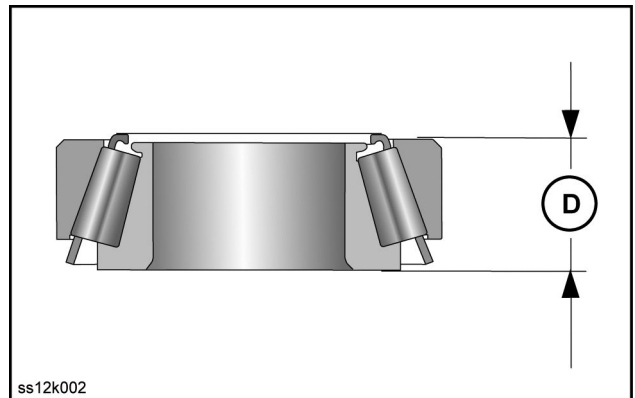

7. For correct adjustment of the differential, dimension (**S**) (adjusting shim thickness) has to be determined.

e.g.: **(S) = (A) - (B) + (D)**

In this case:

**(S) = 225.1 mm (8.86 in) - ( 183.9 mm (7.24 in) + 37 mm (1.46 in)) = 4.2 mm (0.17 in)**

To compensate for the difference after the bearing is assembled, the calculated nominal dimension must be reduced by **0.05 mm (0.002 in)**.

Round off the calculated thickness to the nearest tenth of a millimeter.

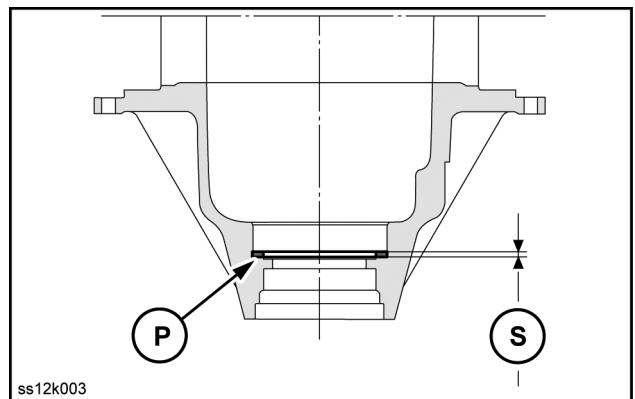

15. Remove the brake carrier plate (17) together with the tapered roller bearing (18) and the O-ring (19) from the brake housing.
16. Check the outer race of the tapered roller bearing (18) for wear, and remove it with a suitable extractor tool if necessary.
17. Use a suitable fitting tool for mounting.

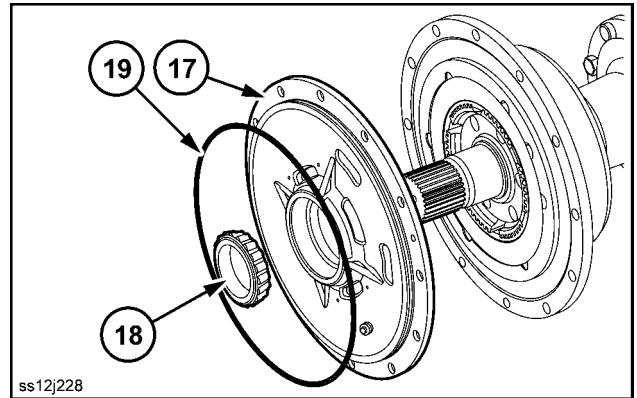

ss12j228

SS12.J228 6

18. Remove the retaining ring (20).
19. Remove the brake disk carrier (21).
20. Remove the brake disks (22) and steel disks (23) from the brake disk carrier (21).

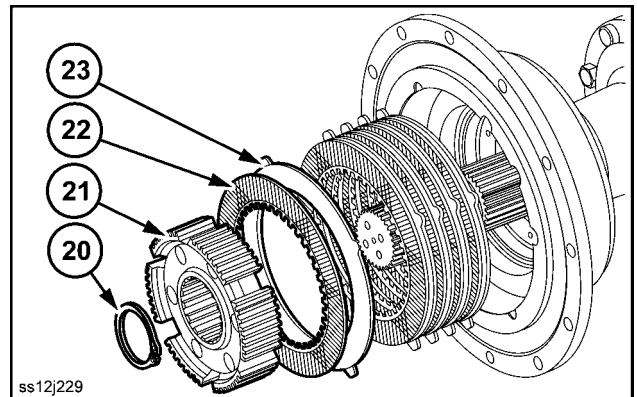

ss12j229

SS12.J229 7

21. Mount the special tool (4A95444).
22. Remove the locking pin (27).
23. Place the special tool (4A95444) and fasten the tool nuts so that the retaining rings (24) can be removed.
24. Remove the special tool (4A95444).
25. Remove the spring retainer (25) and the springs (26), and set them aside.
26. Remove the brake piston (28).

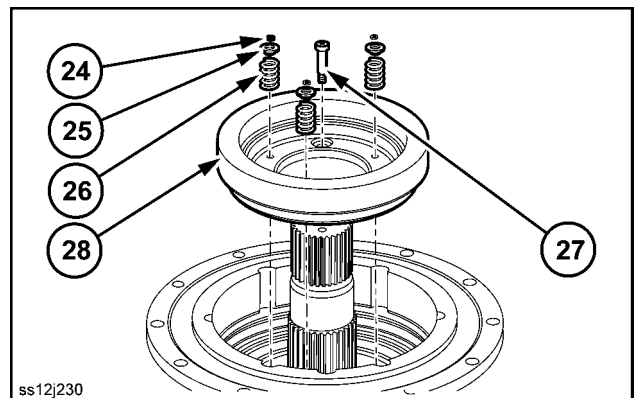

ss12j230

SS12.J230 8

27. Press the output shaft (29) out of the brake housing (30).

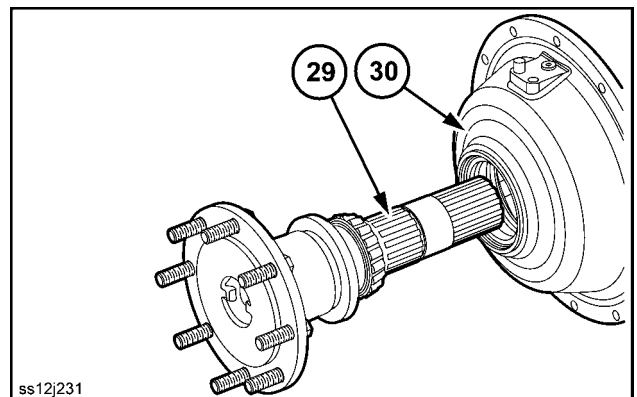

ss12j231

SS12.J231 9

## Planetary final drive - Remove – Half-axle

F106.8A	WE
F106.8	WE
F156.8A	WE
F156.8	WE

### **⚠ WARNING**

#### **Heavy objects!**

**Lift and handle all heavy components using lifting equipment with adequate capacity. Always support units or parts with suitable slings or hooks. Make sure the work area is clear of all bystanders. Failure to comply could result in death or serious injury.**

W0398A

#### **Prior operation:**

**Tandem axle - Remove (27.600).**

**Planetary and final drives - Remove – Swivel mechanism (27.120).**

1. Using a suitable holder to prevent accidents, bring the axle into vertical position.

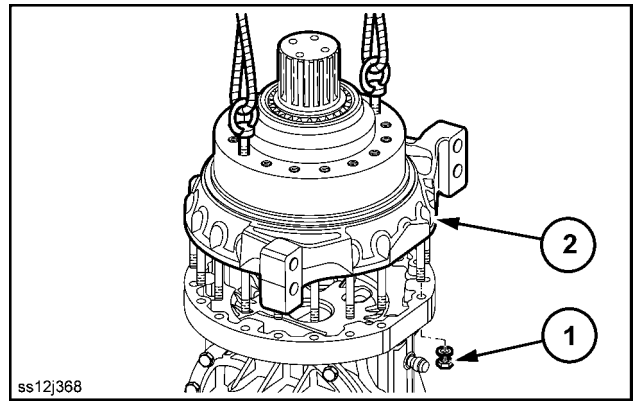

SS12J368 1

2. Unscrew the 18 hexagon nuts (1) and lift the axle housing (2) using lifting gear.

## Tandem axle - Dimension

F106.8A	WE
F106.8	WE
F156.8A	WE
F156.8	WE

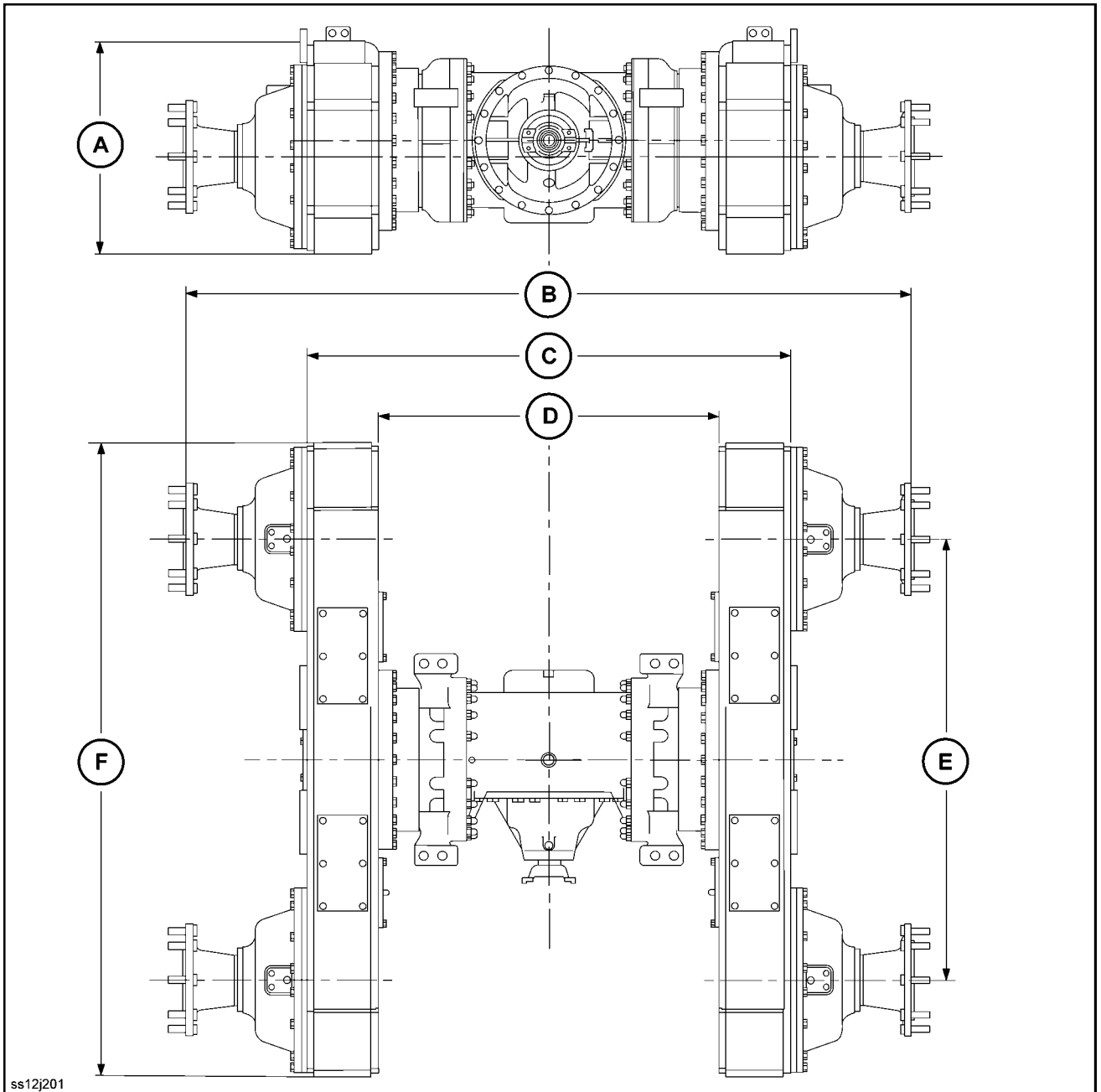

ss12j201

SS12J201 1

Main dimensions of tandem axle F106.8/F106.8A

Pos.	Value	Pos.	Value
A	599 mm (23.58 in)	D	958 mm (37.72 in)
B	2040 mm (80.31 in)	E	1241 mm (48.86 in)
C	1360 mm (53.54 in)	F	1784 mm (70.24 in)

**Tandem axle F156.8/F156.8A**

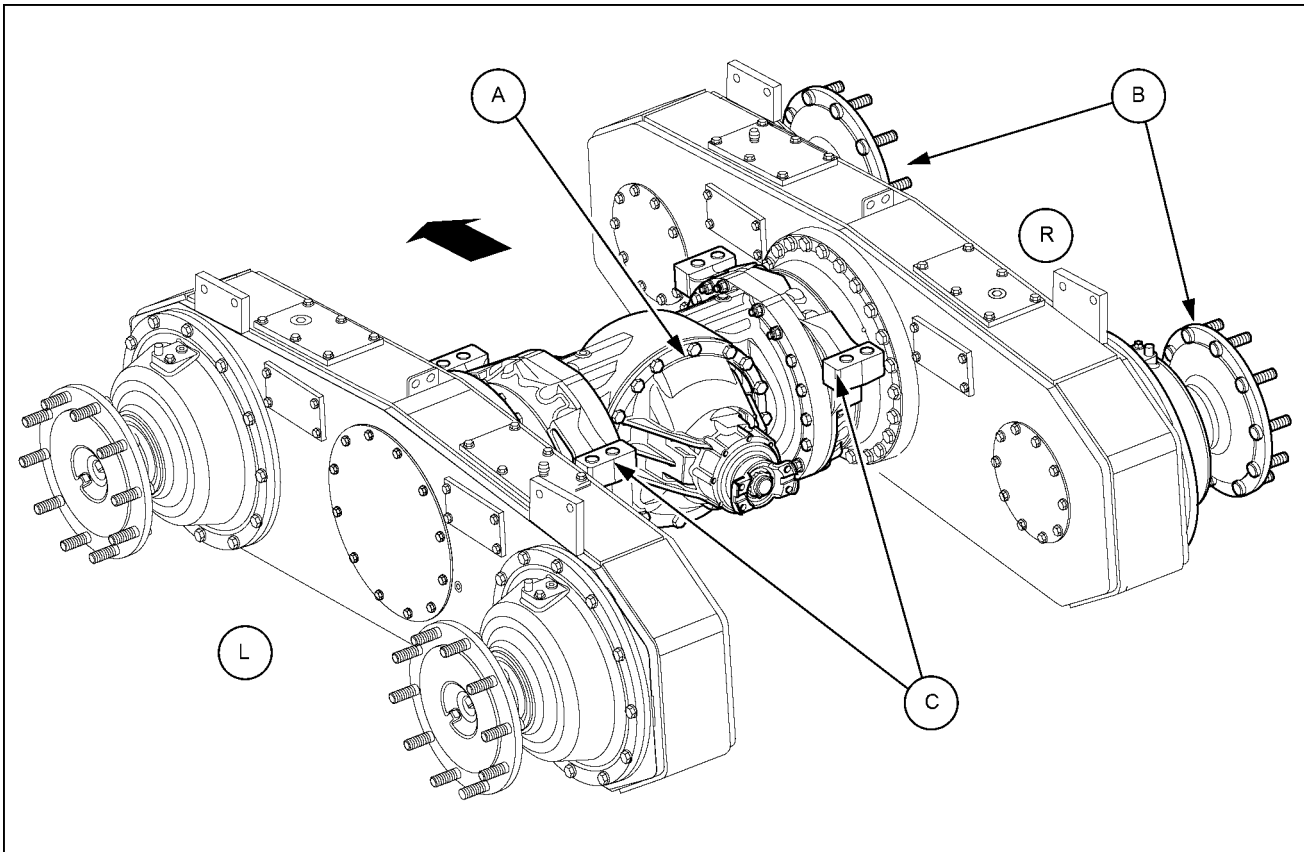

SS14H025 3

Pos.	Designation	Pos.	Designation
A	Differential	L	Left
B	Wheel hubs	R	Right
C	Attachment point		

## Tandem axle - Install

F106.8A	WE
F106.8	WE
F156.8A	WE
F156.8	WE

### ⚠ WARNING

#### Heavy objects!

Lift and handle all heavy components using lifting equipment with adequate capacity. Always support units or parts with suitable slings or hooks. Make sure the work area is clear of all bystanders. Failure to comply could result in death or serious injury.

W0398A

### ⚠ CAUTION

#### Pinch hazard!

Always use suitable tools to align mating parts. DO NOT use your hand or fingers. Failure to comply could result in minor or moderate injury.

C0044A

**NOTICE:** Hydraulic fluid may flow out when the brake lines are loosened. This fluid should be collected and properly disposed of.

1. With the vehicle raised, push the tandem axle under the frame.
2. Raise the tandem axle and align the mounting bolt holes on rear frame and tandem axle.

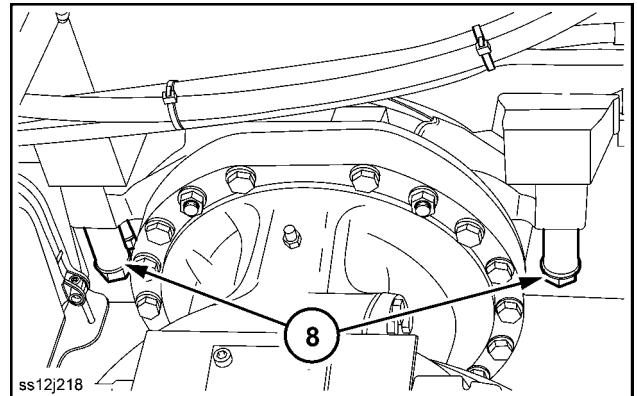

SS12J218 1

3. The rear axle is fixed to the rear frame using the eight bolts (8) and the eight sleeves.
4. Take out the vehicle jack and release the lifting gear.
5. Tighten the bolts with **560 N·m (413.0 lb ft)**.
6. Connect the brake lines (4) on both sides (axle centre section).

**NOTE:** Note the length required to compensate for swinging movements of the rear axle. If the pipe clamp is to be loosened, the brake lines must be fastened so that a gap of min. **380 mm (15.0 in)** is maintained between the pipe clamp and the hose fitting.

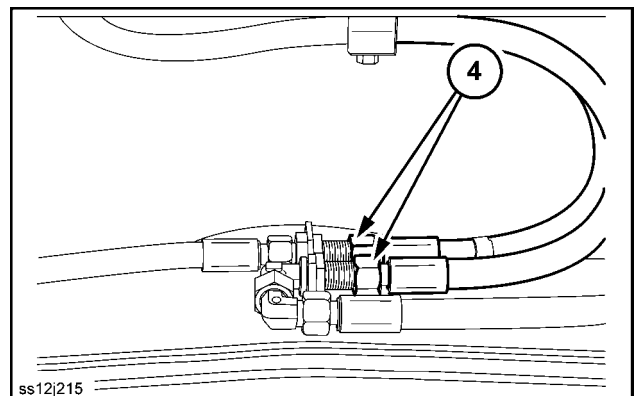

SS12J215 2

# Contents

---

## Hydrostatic drive - 29

[29.204] Reservoir, cooler, and lines .....	29.1
[29.218] Pump and motor components.....	29.2

Hydrostatic drive - Reservoir, cooler, and lines

<b>Pos.</b>	<b>Designation</b>	<b>Pos.</b>	<b>Designation</b>
11	Hose	25	Clamp
12	Hose	26	O-ring
13	Hose	27	Clamp
14	Clamp		

23. Connect the hose (12) to the valve (6).

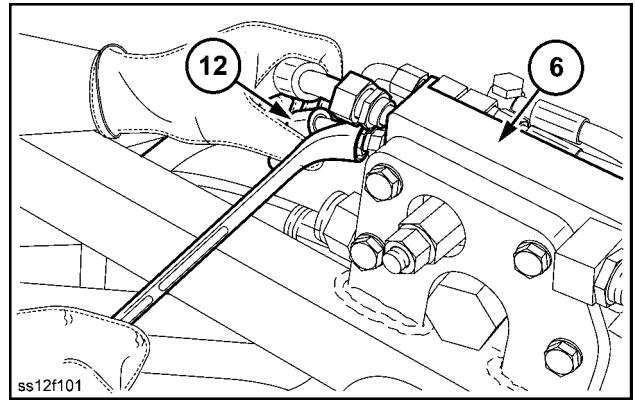

SS12F101 20

24. Connect the hose (13) to the valve (6).

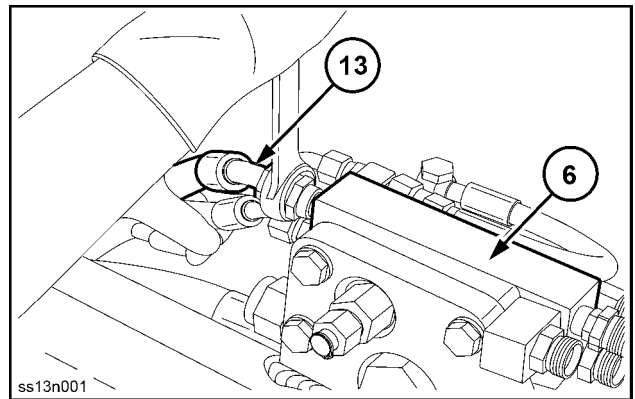

SS13N001 21

## Motor - Static description – Wheel motors

F106.8A	WE
F106.8	WE
F156.8A	WE
F156.8	WE

The two wheel hub motors **(2)** operate according to the radial piston principle. i.e. a certain number of working pistons are arranged radially in the motors. When the cylinder block is turning, they run out along a cam track, which converts their movement to linear movement.

On the inside, the cylinder compartments are connected through the distributor alternately to the high-pressure feed and return lines. When the 6/2 way valve is actuated, the working/feed pressure is applied from inside to the piston surface, pushing the piston into the cam track.

Outside of the piston is the housing or leak pressure which, in our system, is pre-loaded at **1.5 bar (21.8 psi)** by the wheel motor connections of pressure-limiting valve **(19)**.

The purpose of the preload pressure is to switch the wheel motors to freewheel when the front wheel drive is switched off, i.e. to push the radial pistons inward so that they are no longer in contact with the cam track. To do this, the pressure on the inside of the pistons, and therefore in the high-pressure channels must fall to tank pressure. This is done by connecting the wheel motor high-pressure connections to the tank through the 6/2 way valve **(16)** when the front wheel drive is shut off. To assist the wheel motor shutoff, this line opens onto the intake line (connection) of the working hydraulic pump.

The front wheel drive can only be switched on/off up to a vehicle speed of **2 km/h (1.2 mph)**, because, at higher speeds, the wheel motor shutoff might cause damage.

**NOTE:** Refer also to **Pump - Static description (29.218)**.

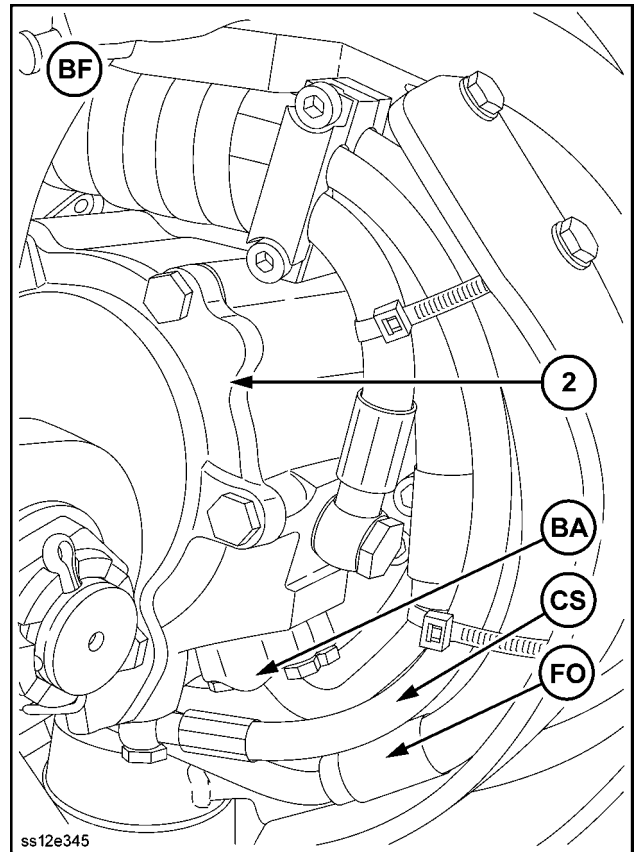

Pos.	Designation
2	Motor
BA	High-pressure line backwards
BF	Side view, before
CS	Control line chamber switch-over
FO	High-pressure line forwards

## Pump and motor components - Service instruction – General information (F106.8A and F156.8A)

F106.8A	WE
F106.8	WE
F156.8A	WE
F156.8	WE

For the programming and diagnosis of the front-wheel drive, a laptop with Engineering Service Tool version 7.7.0.18 or higher shall be connected to the machine via CAN 2 connector.

1. After starting the EST Tool, select the New Holland Construction logo on the left side.

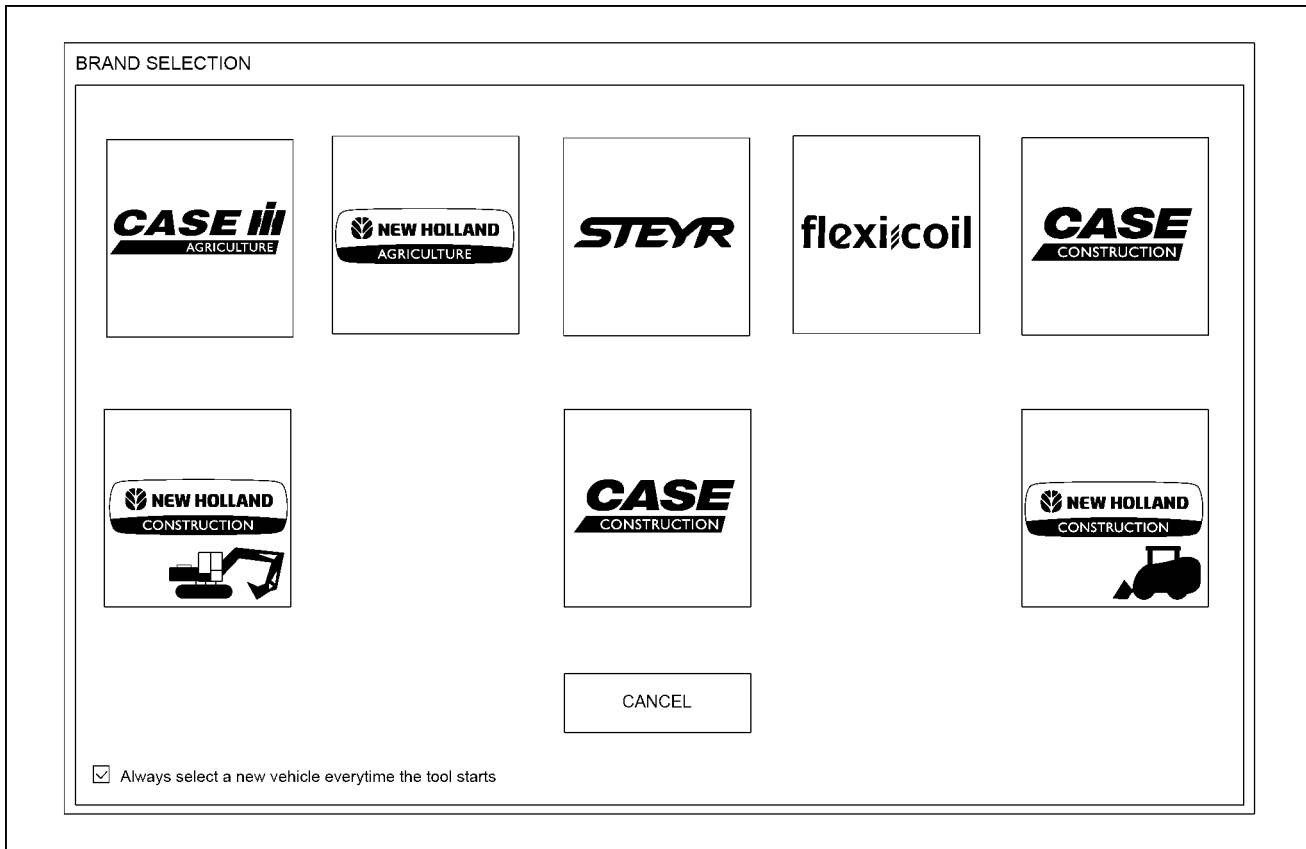

SS14K161 1

1. Press 'Retrieve Controllers values' button to repopulate the column Current values with parameter currently used by the controller.
2. Overwrite values in column Modified values to activate 'SEND MODIFIED VALUES TO CONTROLLER' button.
3. Press 'SEND MODIFIED VALUES TO CONTROLLER' button to make the controller use the modified parameter.
4. Press 'EXIT' button to exit the parameter adjustment procedure.

The following table provide all parameters and their meaning used by FWD Controller:

Parameter Name	Description
Max. Pump Displacement	Maximum nominal pump displacement
Min. Pump Current FW	Minimum nominal pump current forward
Min. Pump Current RV	Minimum nominal pump current reverse
Max. Pump Current FW	Maximum nominal pump current forward
Max. Pump Current RV	Maximum nominal pump current reverse
Min Solenoid Pump Current	Minimum pump current for coil exciting
Max. Motor Displacement	Maximum motor displacement
Motor Reduction Valve Delay On	Time delay from detecting gear stage change to supplying the motor displacement reduction valve (off → on)
Motor Reduction Effect Delay On	Time delay from detecting gear stage change to evaluating the reduced displacement for pump displacement calculation (off → on)
Motor Reduction Valve Delay Off	Time delay from detecting gear stage change to stop supplying the motor displacement reduction valve (on → off)
Motor Reduction Effect Delay Off	Time delay from detecting gear stage change to evaluating the reduced displacement for pump displacement calculation (on → off)
FWD Enable Speed	Speed threshold for enabling front wheel drive
FWD Enable Speed Debounce Time	Time threshold for enabling front wheel drive in Standstill
Transm. Wheel Ratio	Ratio transmission output to wheel
Max. Gear FW	Highest allowed gear to use with FWD in forward direction
Max. Gear RV	Highest allowed gear to use with FWD in reverse direction
Full Displ. Gear Limit FW	Last gear stage in forward direction where motor can be driven at full displacement.
Full Displ. Gear Limit RV	Last gear stage in reverse direction where motor can be driven at full displacement.
Engine Pump Ratio	Ratio diesel engine to pump
FWD Disable Engine Speed	Engine rpm threshold for switching off FWD system
Selector Disable Engine Speed	Engine rpm threshold for disabling rotary selector switch
Selector Enable Engine Speed	Engine rpm threshold for enabling rotary selector switch
Selector Step Size FW 1	Pump displacement aggressiveness step sizes for gear stages F1
Selector Step Size FW 2	Pump displacement aggressiveness step sizes for gear stages F2
Selector Step Size FW 3	Pump displacement aggressiveness step sizes for gear stages F3
Selector Step Size FW 4	Pump displacement aggressiveness step sizes for gear stages F4
Selector Step Size FW 5	Pump displacement aggressiveness step sizes for gear stages F5
Selector Step Size FW 6	Pump displacement aggressiveness step sizes for gear stages F6
Selector Step Size RV 1	Pump displacement aggressiveness step sizes for gear stages R1
Selector Step Size RV 2	Pump displacement aggressiveness step sizes for gear stages R2
Selector Step Size RV 3	Pump displacement aggressiveness step sizes for gear stages R3
Gear Comp. Displ. FW 1	Pump displacement compensation for gear stages F1
Gear Comp. Displ. FW 2	Pump displacement compensation for gear stages F2
Gear Comp. Displ. FW 3	Pump displacement compensation for gear stages F3
Gear Comp. Displ. FW 4	Pump displacement compensation for gear stages F4
Gear Comp. Displ. FW 5	Pump displacement compensation for gear stages F5

### Part 3 FORWARD MAX AGGRESSIVENESS

Check that hydraulic oil temperature is in the range **45 - 55 °C (113 - 131 °F)**.

Set aggressiveness to maximum and FWD active (or requested).

1. Preselect 1st gear when machine in neutral.
2. Starting from standstill drive the machine FW at maximum engine speed in 1st gear.
3. Measure FW and RV pressures.
4. Increase (decrease) Selector Step Size FW 1 value in step of 0.2 ccm (0.0068 ounces) if pressure FW is below (above) **180 - 220 bar (2610 - 3190 psi)**.
5. Repeat the maneuver until the measured pressures are inside the range (decrease the step size if needed).
6. Preselect 1st gear when machine in neutral.
7. Starting from standstill drive the machine FW at maximum engine speed in 1st gear, then upshift to 2nd gear.
8. Measure FW and RV pressures.
9. Increase (decrease) Selector Step Size FW 2 value in step of 0.2 ccm (0.0068 ounces) if pressure FW is below (above) **80 - 120 bar (1160 - 1740 psi)**.
10. Repeat the maneuver until the measured pressures are inside the range (decrease the step size if needed).
11. Preselect 1st gear when machine in neutral.
12. Starting from standstill drive the machine FW at maximum engine speed in 1st gear, then upshift up to 3rd gear (in each gear maximum speed shall be reached).
13. Measure FW and RV pressures.
14. Increase (decrease) Selector Step Size FW 3 value in step of 0.2 ccm (0.0068 ounces) if pressure FW is below (above) **100 - 140 bar (1450 - 2030 psi)**.
15. Repeat the maneuver until the measured pressures are inside the range (decrease the step size if needed).
16. Preselect 1st gear when machine in neutral.
17. Starting from standstill drive the machine FW at maximum engine speed in 1st gear, then upshift up to 3rd gear (in each gear maximum speed shall be reached).
18. Downshift in 2nd gear.
19. Measure FW and RV pressures.
20. Decrease Selector Step Size FW 2 value in step of 0.1 ccm (0.0034 ounces) if pressure FW is below higher than **200 bar (2900 psi)**.
21. Repeat the maneuver until the measured pressures are inside the range (decrease the step size if needed).
22. Preselect 1st gear when machine in neutral.

### **Checking the switching ON and OFF of the front-wheel drive at speeds over and less than 2.0 km/h (1.2 mph).**

1. Drive the grader at a speed faster than **2.0 km/h (1.2 mph)** with the front-wheel drive switched off.
2. Engage the front-wheel drive while driving!  
Desired condition: Front Wheels do not turn.
3. Reduce the speed so far that the front-wheel drive automatically engages at **2.0 km/h (1.2 mph)**.  
Desired condition: Front Wheels turn.
4. Accelerate to exceed **2.0 km/h (1.2 mph)**.
5. Disengage the front-wheel drive while driving!  
Desired condition: Front Wheels keep turning.
6. Reduce the speed so far that the front-wheel drive automatically disengages at **2.0 km/h (1.2 mph)**.  
Desired condition: Front Wheels do not turn.

### **Testing the displacement reduction when braking:**

At each brake application the hydraulic pump is displaced backward by reduction of the pump flow rate, in order to prevent front wheel caster or engine overloading.

If the "Brake Comp. Displ." parameter is set to zero, this function is disabled!

Test procedure:

- Open the EOL Adjustment screen menu on EST and check that "Brake.Comp.Displ" is set to -17.8 ccm.
- Machine lifted
- FWD switched on and first gear selected
- Diesel engine at maximum engine rpm
- Press service brake

Desired condition: Rear wheel shall reduce the speed but keep turning, while the front wheels shall stop since when brakes are applied the pump displacement is reduced by the value.

---

## Hydraulic service brakes - Dynamic description

F106.8A	WE
F106.8	WE
F156.8A	WE
F156.8	WE

**NOTE:** See also *Hydraulic service brakes - Component identification (33.202)*.

The shutoff valve **(2)** is installed separately on the left under the cab floor. It regulates the pressure-filling of the brake system nitrogen reservoir **(4)** to the **50 bar (725.0 psi)** preload pressure. If the pressure is at **142 - 150 bar (2059 - 2175 psi)**, the oil feed is shut off. If the pressure falls to **120 - 128 bar (1740 - 1856 psi)**, the reservoir is refilled. The actuation and shutoff pressures can be tested at a measuring point on the shutoff valve (outlet 28).

Two nitrogen reservoirs **(4)** are mounted on the rear frame, on the front left in the direction of travel. These provide the reservoir pressure for the two brake circuits. The 3rd nitrogen reservoir **(4)** is attached directly to the shutoff valve **(2)**. It dampens switching knocks in the valve and provides additional reservoir pressure to the brake circuits.

The brake valve **(101)** is actuated directly by the brake pedal. When the brake pedal is operated, a **4 bar (58.0 psi)** pressure switch **(102)** (S18) at the brake valve **(101)** activates the power supply to the brake lights. In the brake valve, the maximum brake pressure is limited to **56 - 64 bar (812 - 928 psi)**.

## Hydraulic service brakes - Bleed

F106.8A	WE
F106.8	WE
F156.8A	WE
F156.8	WE

### **⚠ WARNING**

**Unexpected machine movement!**

**Make sure that you secure the machine with wheel chocks before you perform this procedure. Failure to comply could result in death or serious injury.**

W1221A

**NOTE:** Bleeding is always necessary if a brake system component was changed (brake valve, brake lines,.....). Also after repair or leakage of brake system components, or after hydraulic oil change.

1. Secure the machine.
2. Attach a "DO NOT OPERATE" maintenance tag. This tag has to be applied to both cab doors or to the steering wheel.

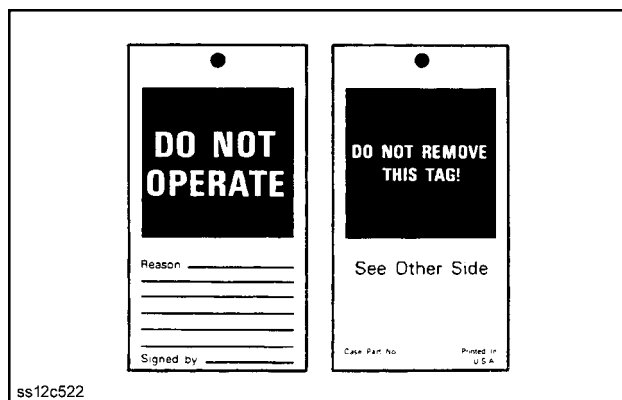

ss12c522

SS12C522 1

3. Apply the parking brake.
4. Remove the plastic caps from all four air-bleeders. Two on the left-hand side and two on the right-hand side above the wheel hubs.

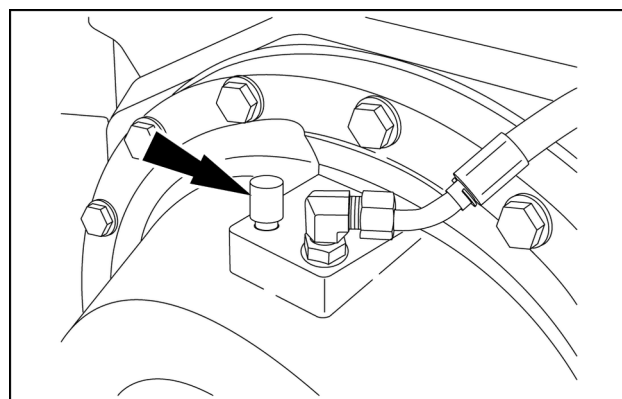

SVIL14GRD0024AA 2

### **⚠ WARNING**

**Unexpected machine movement!**

**Before you start the engine, put the gearshift lever in the neutral position. Be aware that the gearshift lever will remain in the neutral position throughout the complete bleed-off procedure.**

**Failure to comply could result in death or serious injury.**

W1388A

5. Start the engine.
6. Check that all-wheel (option) is deactivated.

disk, the reaction force pushes the brake onto guide pins **(9)**, against the spring force of rubber spring elements **(10)**, until the second brake lining carrier **(8)** is also pressed against the brake disk. The braking effect (braking torque) depends on the friction coefficient of the brake linings.

The brake is released by the full pre-loading of the disk spring pack **(5)**. The required minimum release pressure causes the piston **(6)** back to the stop on the thrust ring **(2)**.

During this process, the brake is moved by the two rubber spring elements **(10)** to the position set by the setting screw **(11)**. An equal air gap on both sides of the brake disk can only be ensured by proper adjustment.

Wear on the brake linings **(7)** and **(8)** and on the brake disk causes the clamping force to be reduced. In this case, the brake must be adjusted.



## Hydraulic systems - Dynamic description – Main functions

F106.8A	WE
F106.8	WE
F156.8A	WE
F156.8	WE

### General information

The hydraulic system is divided into the following areas:

- Working hydraulics
- Brakes / steering
- Oil cooling
- All-wheel drive (F106.8A and F156.8A)

### Working equipment

The working equipment is adjusted hydraulically by the hydraulic cylinders, which are controlled by the operator through the control blocks.

### All-wheel drive (F106.8A and F156.8A)

On Graders F106.8A and F156.8A, a front wheel drive can be engaged in addition to the rear axle drive.

### Brakes / steering

Please refer to **Hydraulic service brakes - General specification (33.202)** for the brake and **Hydraulic control components - General specification (41.200)** for the steering.

### Oil cooling

The fan drive oil circuit consists of the following components:

- Double gear pump
- Shutoff valve
- Fan motor
- Hydraulic fluid tank

The fan drive oil circuit is part of the brake and fan circuit. Oil is supplied at stage 1 of the double gear pump (Displacement value = **19 cm<sup>3</sup> (1.2 in<sup>3</sup>)** (for F106.8/F106.8A) or **23 cm<sup>3</sup> (1.4 in<sup>3</sup>)** (for F156.8/F156.8A)). This delivers oil to the shutoff valve, which supplies the fan motor according to the oil requirement of the brake system.

The fan motor consists of a fixed-displacement motor with a specific direction of rotation (left-hand). It is equipped with a pressure-limiting valve cartridge.

The pressure relief valve controls the maximum pressure in the fan motor. The opening pressure is adjusted according to the required cooling output.

The speed at the fan wheel at high idle speed and with the hood closed is **1840 - 1860 RPM**.

If there is insufficient oil supply through the motor's P channel, an integrated replenishing valve allows oil intake from the hydraulic fluid tank.

A measurement coupling is provided on the motor housing for monitoring the prevalent pressure level. The oil return from the fan motor passes directly through a hose to the tank.

<b>Pos.</b>	<b>Designation</b>
1	Pump assembly
4	Gear pump
10	Hydro-reservoir
11.1	4-circuit cooler
11.2	Fan motor
20	Steering assistance
21	Steering/emergency steering collector block with pressure switches S17 ( <b>2.5 bar (36.3 psi)</b> ) and 17.6 ( <b>2.5 bar (36.3 psi)</b> )
22	Steering cylinder
23	Emergency steering pump
25	Pressure limiting valve, purge circuit
30	LS valve block
31	Control block, lower installation position
32	Control block, upper installation position
36	Lowering control valve, Pitch adjustment cylinder
40	Brake valve with pressure switch S18 ( <b>4 bar (58.0 psi)</b> )
41	Brake valve with pressure switch S17.1 ( <b>90 bar (1305.0 psi)</b> ) Cut-in pressure ( <b>120 - 128 bar (1740 - 1856 psi)</b> ) Shutoff pressure ( <b>142 - 150 bar (2059 - 2175 psi)</b> )
42	Pressure reservoir, brake system
43	Pressure reservoir, parking brake ( <b>30 bar (435.0 psi)</b> )
44	Pressure reservoir, parking brake ( <b>90 bar (1305.0 psi)</b> )
45	Parking brake, solenoid valve with pressure switch S16 ( <b>80 bar (1160.0 psi)</b> )
46	Fitting with nozzle $\pm 0.8$ mm ( <b>0.03 in</b> )
47	Parking brake release pressure ( <b>150 bar (2175.0 psi)</b> )
48	Wet multi-disk brake (max. operating pressure <b>60 bar (870.0 psi)</b> )
80	Blade lift cylinder, left and right
81	Lowering control valve
82	Scraper blade cylinder
83	Hydraulic cylinder, articulated steering
84	Pitch adjustment cylinder
85	Hydraulic cylinder, blade extend
86	Hydraulic cylinder, blade swivel
87	Rotary oil feed rotor
88	Hydraulic cylinder, wheel lean
89	Hydraulic cylinder, rear ripper
90	Hydraulic motor, blade turn
91	Lowering control valve, blade turn
92	Hydraulic cylinder, detent pin

CLICK HERE TO **DOWNLOAD** THE COMPLETE MANUAL

- Thank you very much for reading the preview of the manual.
- You can download the complete manual from: [www.heydownloads.com](http://www.heydownloads.com) by clicking the link below



- Please note: If there is no response to CLICKING the link, please download this PDF first and then click on it.

CLICK HERE TO **DOWNLOAD** THE COMPLETE MANUAL

# Contents

---

## Hydraulic systems - 35

### Reservoir, cooler, and filters - 300

#### TECHNICAL DATA

Oil filters	
General specification (*) .....	3

#### FUNCTIONAL DATA

Oil filters	
Component identification (*) .....	4

(\*) See content for specific models



## **Hydraulic systems - 35**

### **Pump control valves - 102**

**F106.8A**  
**F106.8**  
**F156.8A**  
**F156.8**

# Contents

---

## Hydraulic systems - 35

### Remote control valves - 204

#### SERVICE

##### Electro-hydraulic control valve

Disassemble – Control unit (*) .....	3
Assemble – Control unit (*) .....	8
Assemble – Converter coupling valve (*) .....	16

(\*) See content for specific models

46. Mount the push spring (4), the piston (3), and the switch (2) with the new O-ring 13 mm (0.51 in) x 2 mm (0.08 in).

Tighten the switch with 30 N·m (22.1 lb ft).

- Filter pressure differential valve (1)
- Switch with O-ring (2)
- Piston (3)
- Push spring (4)

**NOTE:** On versions without filter pressure differential valve, mount the screw plug in place of the switch (2).

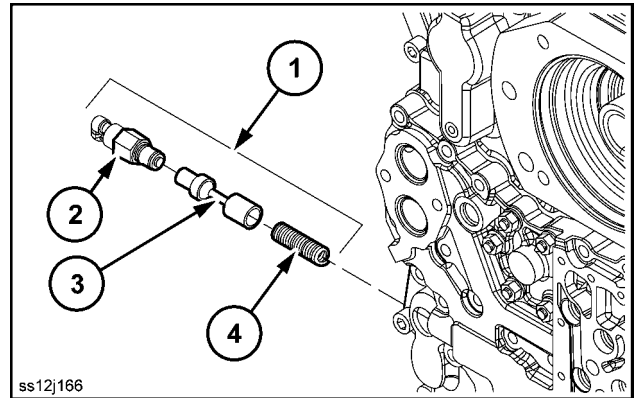

ss12j166

SS12J166 26

47. Mount the adjusting screws (S).

48. Tighten the adjusting screws (M16x1.5) with 30 N·m (22.1 lb ft).

Use the special tool 5870 204 063.

49. Mount the seals (4) and (2), the intermediate panel (3), and the circuit (1).

**NOTE:** Note the differences in the seals!

**NOTE:** Apply mounting grease!

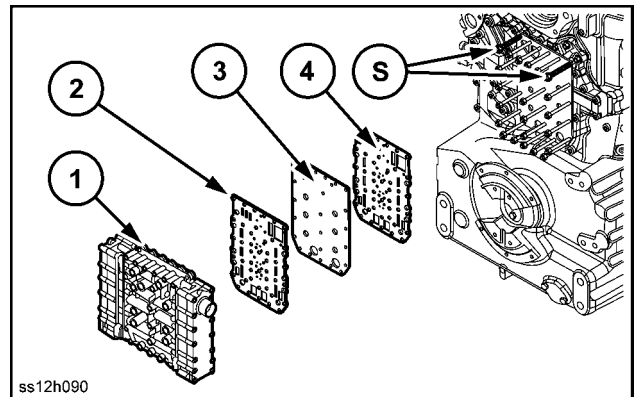

ss12h090

SS12H090 27

50. Fasten the electro-hydraulic control unit (1) evenly, using the torx screws (2).

51. Tighten the torx screws (M6/10.9x80) with 12 N·m (8.9 lb ft)

Use the special tool 5873 042 002.

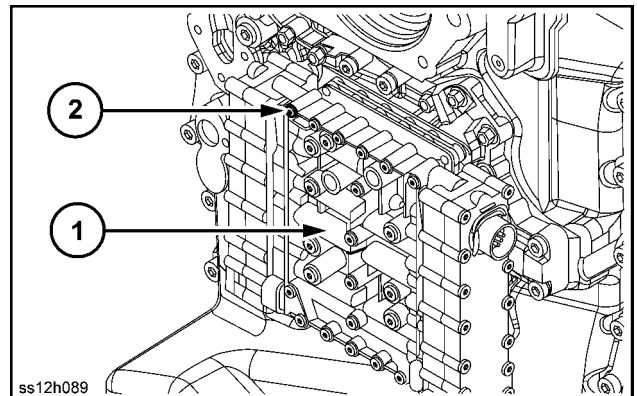

ss12h089

SS12H089 28

**Next operation:**

**Electro-hydraulic control valve - Assemble – Converter coupling valve (35.204)**

# Index

---

## Hydraulic systems - 35

### Swing arm hydraulic system - 739

Swing cylinder - Component identification (*) .....	3
---	---

(\*) See content for specific models

## Ripper control cylinder - Component identification

F106.8A	WE
F106.8	WE
F156.8A	WE
F156.8	WE

### Rear ripper cylinder (optional)

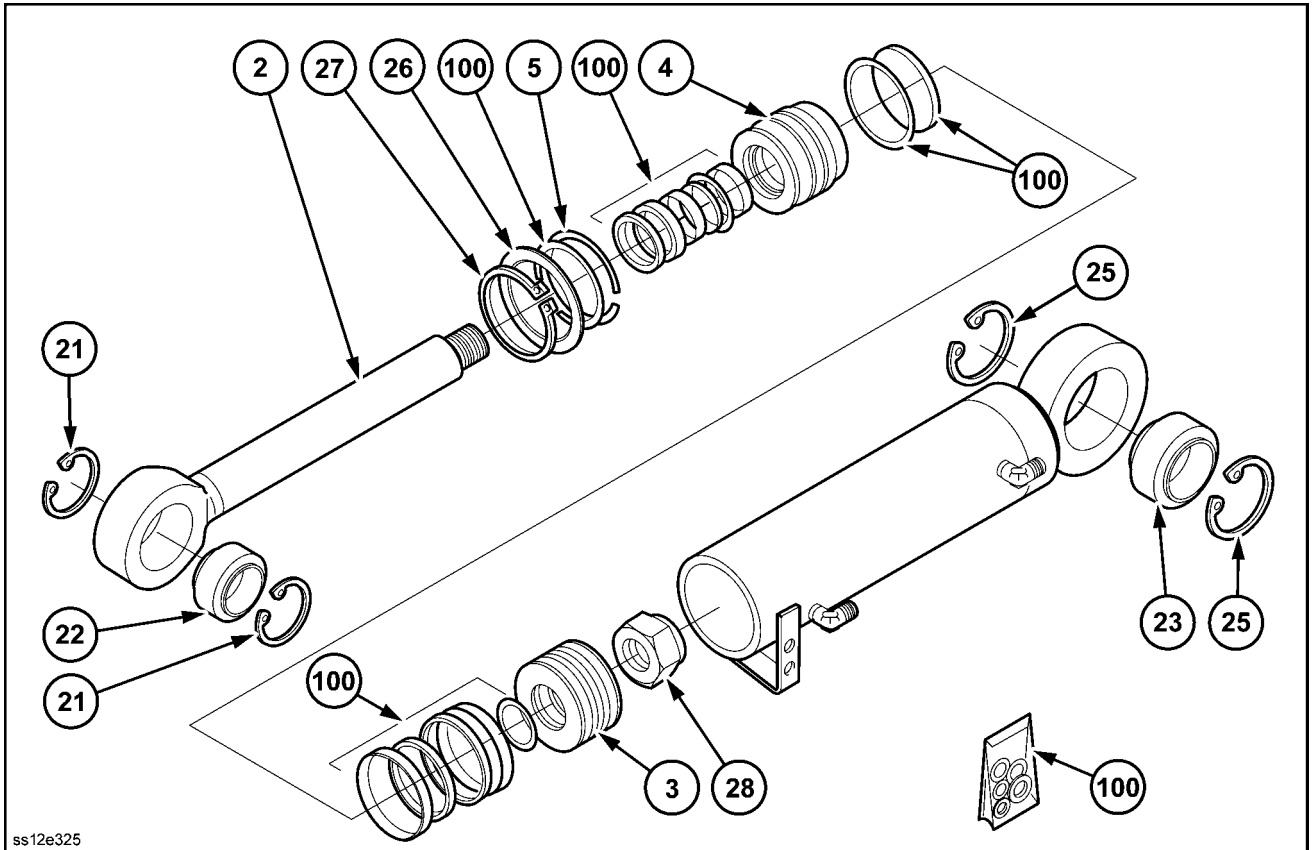

ss12e325

SS12E325 1

Pos.	Designation	Pos.	Designation
2	Piston rod	23	Joint bearing
3	Guide	25	Circlip
4	Piston	26	Support disk
5	Snap ring	27	Circlip
21	Circlip	28	Hexagon nut
22	Joint bearing	100	Seal set

## Supply and pressure check valve - Component identification

F106.8A	WE
F106.8	WE
F156.8A	WE
F156.8	WE

### Ball - Spring design (old)

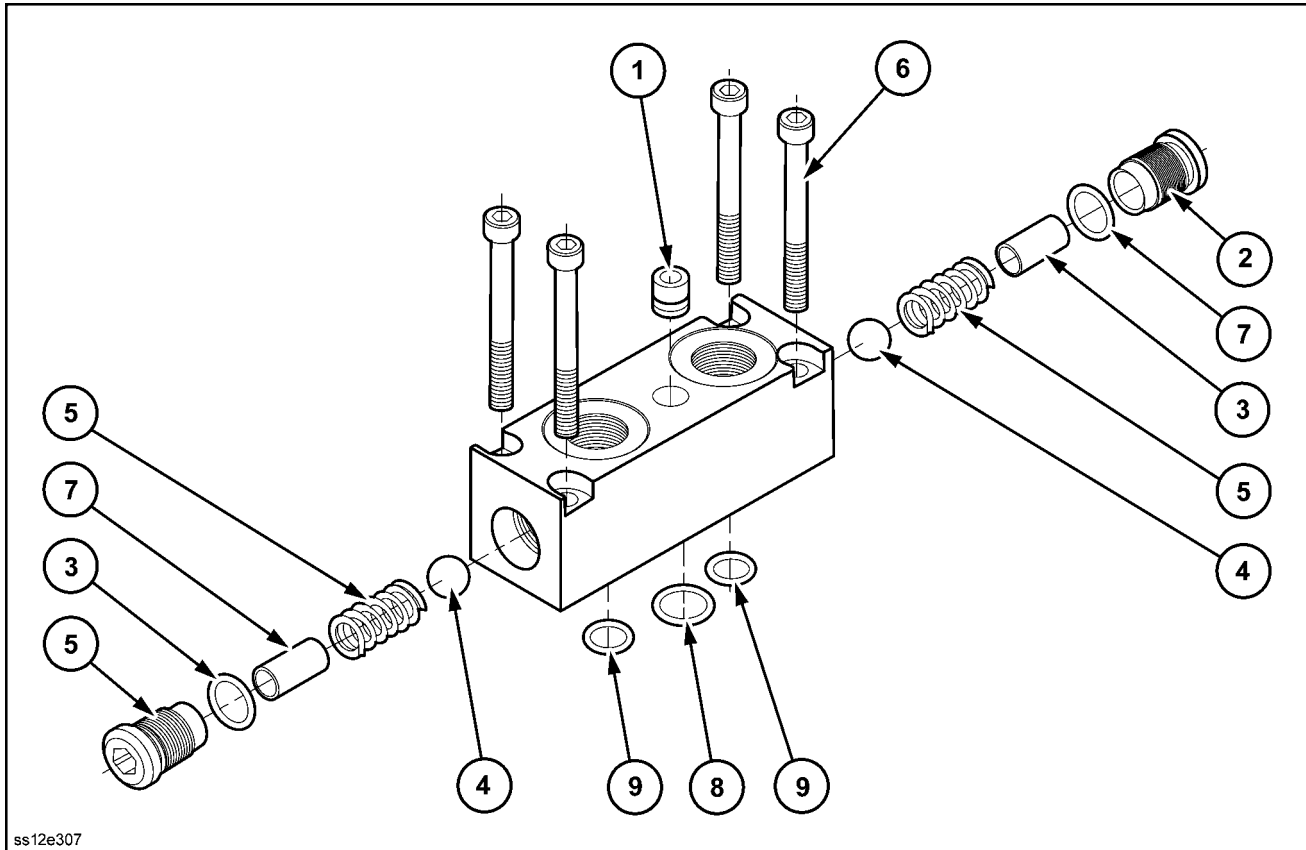

ss12e307

SS12E307 1

Pos.	Designation	Pos.	Designation
1	?	6	Cylinder head screw
2	Screw plug	7	O-ring
3	O-ring	8	Connection to T channel of control valve block
4	O-ring	9	Connection channel to control valve block A/B channel
5	Screw plug		

## Frame - Remove – Front frame

F106.8A	WE
F106.8	WE
F156.8A	WE
F156.8	WE

### Prior operation:

Before separating the front and rear frames, we recommend removing the cab and cab floor.

Refer to **Moldboard blade - Remove (86.112)**.

**Dozer blade - Remove (86.110)**.

**Cab - Remove (90.150)**.

**Cab floor - Remove (90.150)**.

### ⚠ WARNING

**Heavy objects!**

**Lift and handle all heavy components using lifting equipment with adequate capacity. Always support units or parts with suitable slings or hooks. Make sure the work area is clear of all bystanders.**

**Failure to comply could result in death or serious injury.**

W0398A

### ⚠ WARNING

**Avoid injury!**

**Secure and support the front frame and the rear frame with suitable lifting equipment.**

**Failure to comply could result in death or serious injury.**

W1223A

**NOTE:** Use a suitable drift punch for removing the bolts.

1. Disconnect all hydraulic lines and electrical lines between the front frame and rear frame.

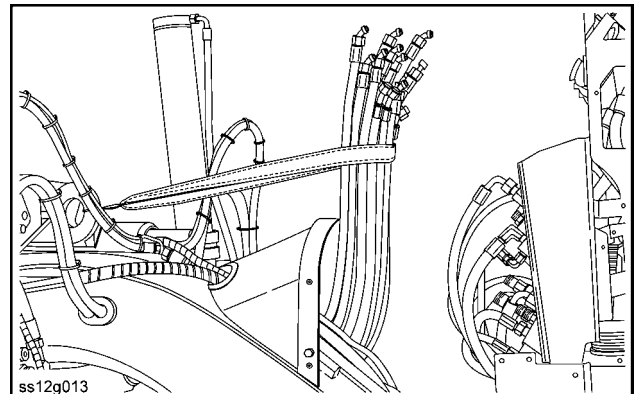

SS12G013 1

2. Release the articulation lock (10) on both sides.

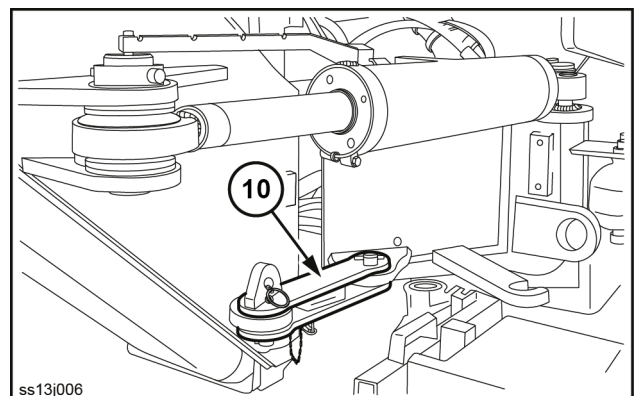

SS13J006 2

# Contents

---

## Steering - 41

### Hydraulic control components - 200

#### TECHNICAL DATA

Hydraulic control components	
General specification (*) .....	3

#### FUNCTIONAL DATA

Hydraulic control components	
Component identification (*) .....	4
Static description (*) .....	7
Dynamic description (*) .....	8
Hydraulic schema (*) .....	13

(\*) See content for specific models

Steering - Hydraulic control components

Pos.	Designation	Pos.	Designation
1	Steering pump	A	Steering pressure warning indicator on the instrument panel
2	Emergency steering pump	B	Track Width: <b>1900 mm (74.8 in)</b> (R = 96) - 405/70 R20
3	Pressure switch S17 ( <b>2 bar (29.0 psi)</b> NC contact)		
4	Pressure switch S17.6 ( <b>5.5 bar (79.8 psi)</b> NC contact)		
6	Oil reservoir		
10	Safety valve <b>12 bar (174.0 psi)</b>	C	Wheel camber adjustment range <b>± 14 ° 24'</b>
11	Collector block	D	Direction of travel
13	Working hydraulic system control blocks	E	Toe-in L -6 / -3
18	Steering servo	F	R = <b>290 mm (11.4 in)</b>
		G	R = <b>288 mm (11.3 in)</b>

4. Fasten the cover (1) with the torx screws (2).

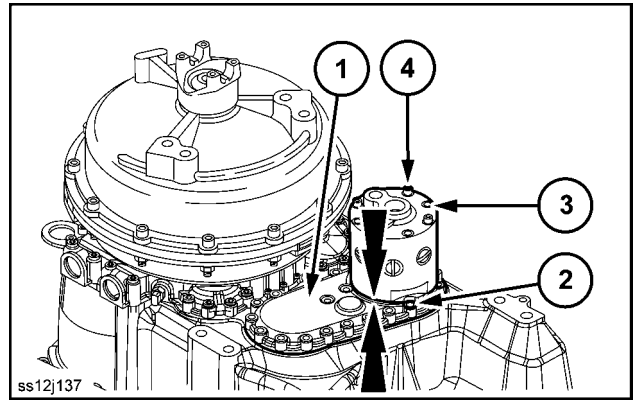

SS12J137 4

5. Tighten the torx screws (M8/10.9x30) with **34 N·m (25.1 lb ft)**.
6. Insert the emergency steering pump (3) and fasten it with cap bolts (4).
7. Tighten the cap bolts (M8/8x135) with **23 N·m (17.0 lb ft)**.

**NOTE:** Note the radial installation position! Refer to the markings made when disassembling.

4. Mount the seals (7) on the head (4).

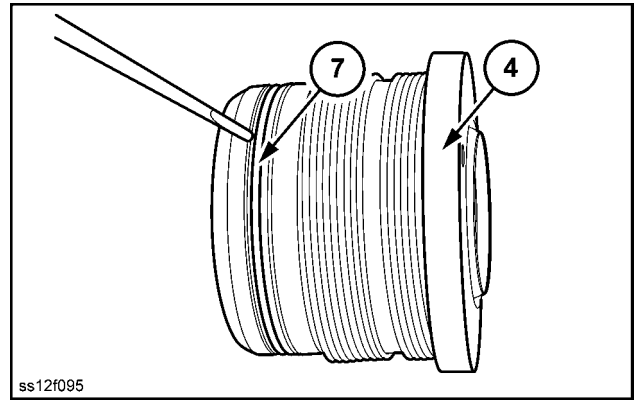

SS12F095 4

5. Insert the inner seals (8) in the head (4).

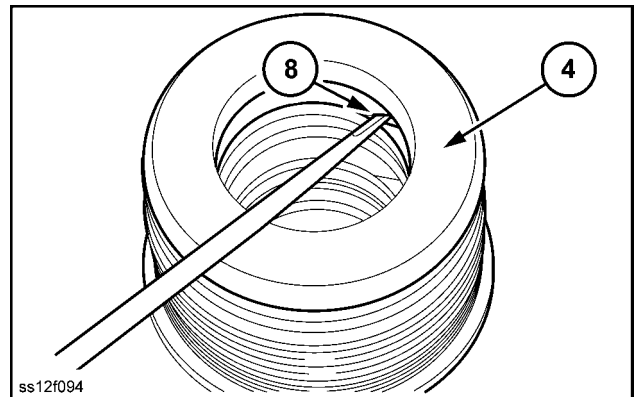

SS12F094 5

6. Mount the rings (11) and (12) on the piston (10).

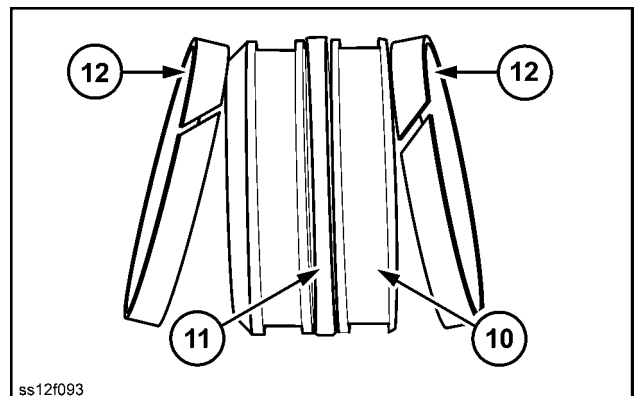

SS12F093 6

7. Insert the O-ring (9) in the piston (10).

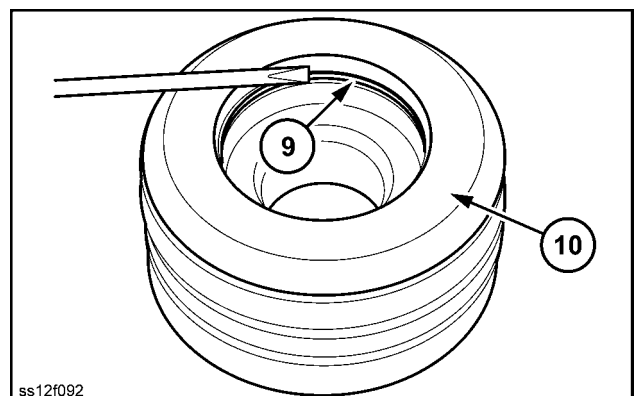

SS12F092 7

# Contents

---

## Wheels - 44

### Front wheels - 511

#### TECHNICAL DATA

Front wheels	
Tire pressure (*) .....	3

#### SERVICE

Front wheels	
Remove (*) .....	4
Install (*) .....	5

(\*) See content for specific models



# SERVICE MANUAL

## Cab climate control

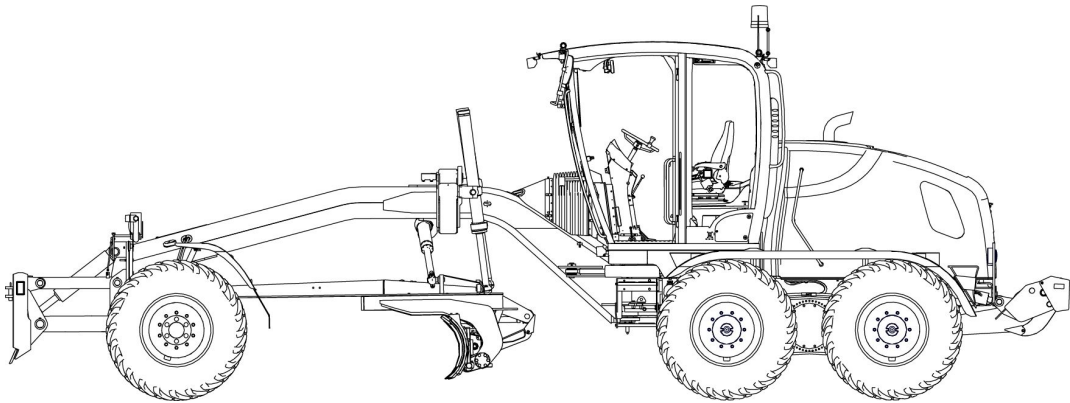

**F106.8A**  
**F106.8**  
**F156.8A**  
**F156.8**

# Contents

---

## Electrical systems - 55

[55.000] Electrical system .....	55.1
[55.100] Harnesses and connectors.....	55.2
[55.302] Battery.....	55.3
[55.988] Selective Catalytic Reduction (SCR) electrical system .....	55.4
[55.989] Exhaust Gas Recirculation (EGR) electrical system .....	55.5
[55.640] Electronic modules .....	55.6
[55.512] Cab controls.....	55.7
[55.530] Camera.....	55.8
[55.408] Warning indicators, alarms, and instruments .....	55.9

Diagram
SH01-A-TITLE BLOCK
SH02-POWER DISTRIBUTION-BATTERY / STARTER
SH03-POWER DISTRIBUTION (FUSE BLOCK 1F/1K)
SH04-POWER DISTRIBUTION (FUSE BLOCK 2F/2K)
SH05-POWER DISTRIBUTION (FUSE BLOCK 3F/3K)
SH06-POWER DISTRIBUTION (FUSE BLOCK 4F/4K)
SH07-POWER DISTRIBUTION (FUSE BLOCK 5F/5K)
SH08-POWER DISTRIBUTION 1
SH09-POWER DISTRIBUTION 2
SH10-POWER DISTRIBUTION 3
SH11-POWER DISTRIBUTION 4
SH12-ENGINE CONTROL UNIT 1, GRID HEATER, FILTER HE...
SH13-ENGINE CONTROL UNIT 2
SH14-ENGINE CONTROL UNIT 3
SH15-ECU - AIC 1
SH16-ECU - AIC 2
SH17-CAN STRUCTURE
SH18-GEAR CONTROL UNIT 1
SH19-GEAR CONTROL UNIT 2
SH20-ECU - UCM POWER SUPPLY
SH21-ECU - UCM
SH22-FLOATING POSITION
SH23-ENGAGER PIN, RAPID HYDRAULIC, PLUG OPERATOR S...
SH24-LIGHTING STEERING COLUMN SWITCH, DOMELIGHT
SH25-LIGHTING HAZARD WARNING, BLINKERS
SH26-LIGHTING HEADLIGHT, FULL BEAM, TAIL, PARKING,...
SH27-LIGHTING BACK UP, REVERSE LIGHT
SH28-LIGHTING WORKING LIGHTS CAB ROOF, FRONT AND R...
SH29-CAB WIPER / WASHER FRONT
SH30-CAB WIPER / WASHER REAR
SH31-HEATING BLOWER HEATER, HVAC
SH32-CABIN DEFROST REAR WINDSCREEN, BEACON
SH33-CABIN RADIO LOUDSPEAKER 12V POWER OUTLET
SH34-MISCELLANEOUS, FUEL SYSTEM
SH35-MISCELLANEOUS, CREEP MODE
SH36-MISCELLANEOUS, BLADE CONTROL
SH37-MISCELLANEOUS, TELEMATICS
SH38-MISCELLANEOUS, REAR CAMERA

**Harnesses and connectors - Electrical schematic sheet 08 – Power distribution 1**

F106.8A	WE
F106.8	WE
F156.8A	WE
F156.8	WE

Location	Component
C6	Cab Ground Block



**Harnesses and connectors - Electrical schematic sheet 21 ECU - UCM**

F106.8A	WE
F106.8	WE
F156.8A	WE
F156.8	WE

Location	Component
A5	Reverse Y8-6
B5	Forward Y8-5
B5	Wheel Motor Y8-2
B5	FWD ON / OFF Y8-1
C1	UCM A157

Electrical systems - Harnesses and connectors

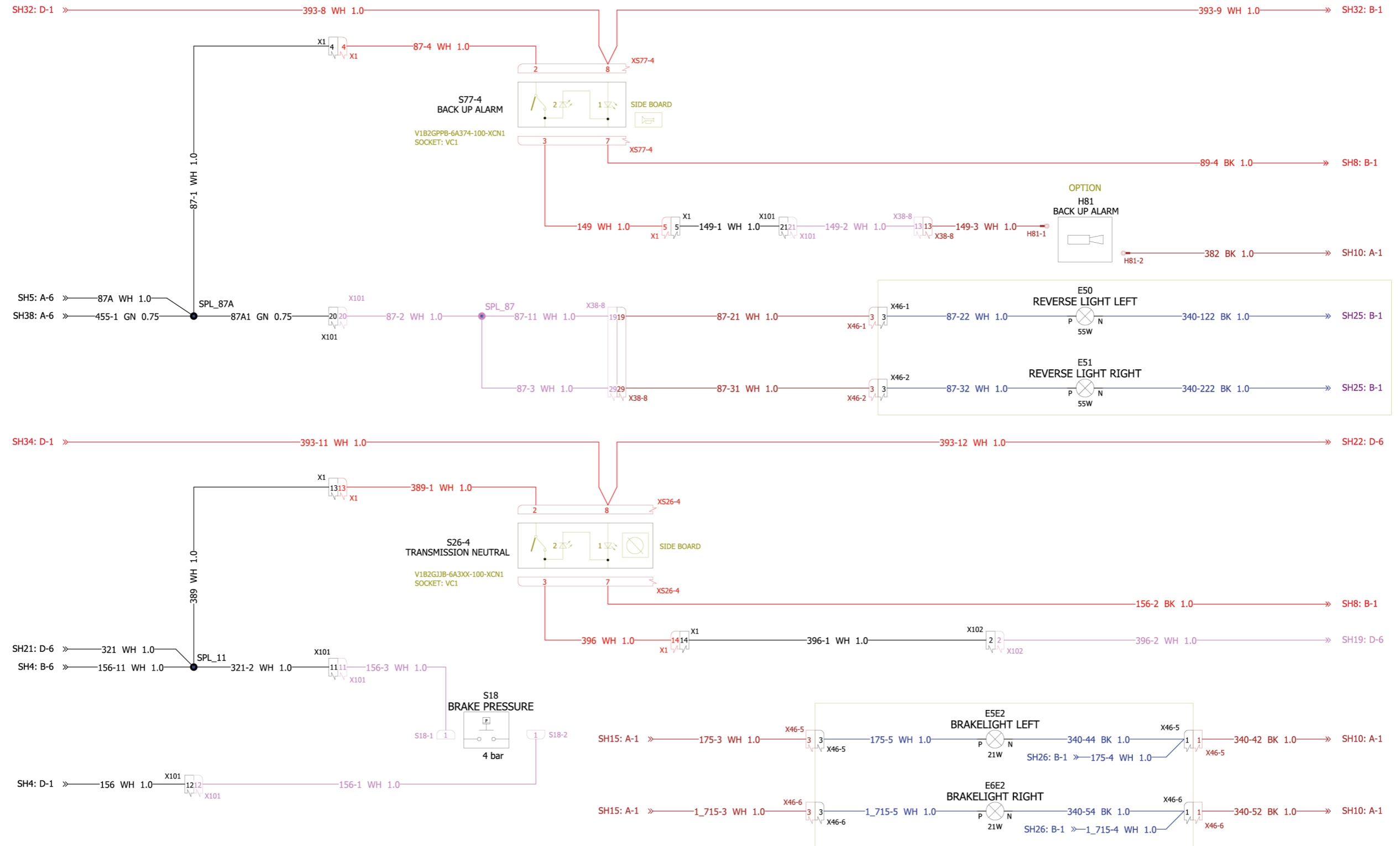

SS14M200 1

**Harnesses and connectors - Electrical schematic sheet 34 –  
Miscellaneous, Fuel system**

F106.8A	WE
F106.8	WE
F156.8A	WE
F156.8	WE

Location	Component
A4	Fueling Pump M67
B4	Level Switch S67-1
B4	Filler Tube S15-5
C4	Fueling System S67

**X33-40 – Engine-Gear / Cab floor**

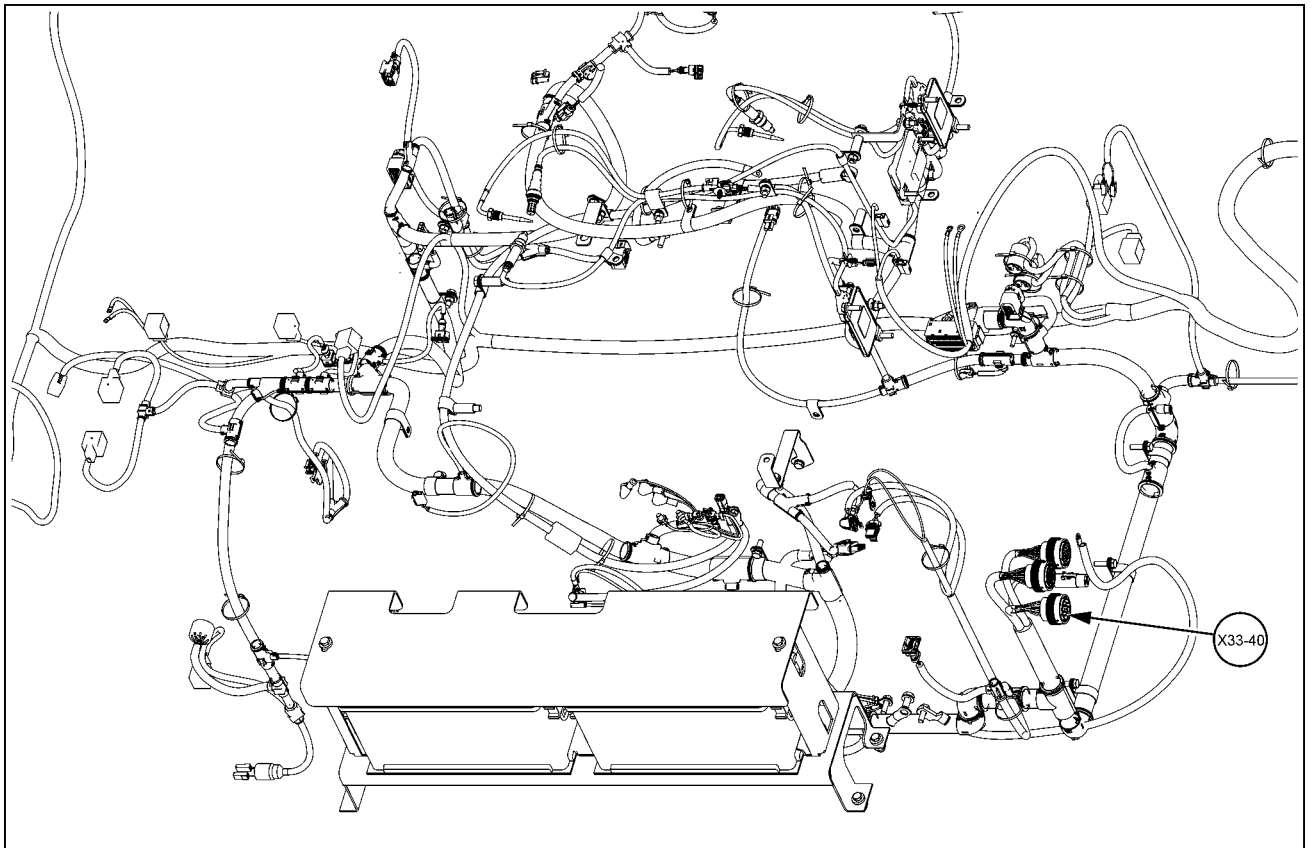

SS14K319 3

**NOTE:** For detailed connector information see: *Harnesses and connectors - Component diagram 01 – Engine / Gear (55.100)* and *Harnesses and connectors - Component diagram 05 – Cab floor (55.100)*.

**Connector XA9 – Gearshift connector**

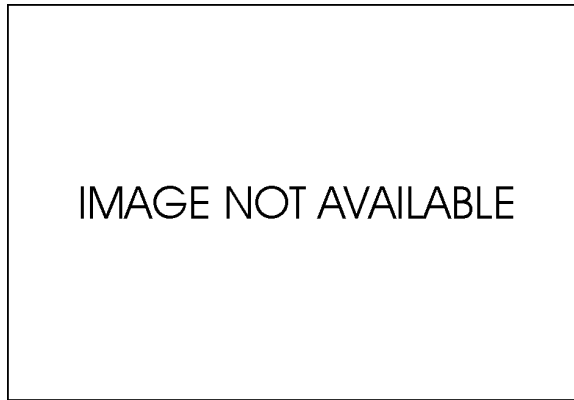

INA 4

Cavity	Wire ID	Circuit	Cavity	Wire ID	Circuit
(1)	362	Gearshift Y1	(6)	367	Gearshift Y6
(2)	363	Gearshift Y2	(7)	368	Gearshift VPS1
(3)	364	Gearshift Y3	(8)	369	Gearshift temp
(4)	365	Gearshift Y4	(9)	371-2	-
(5)	366	Gearshift Y5			

**Connector XB-020 – DEF level / temp**

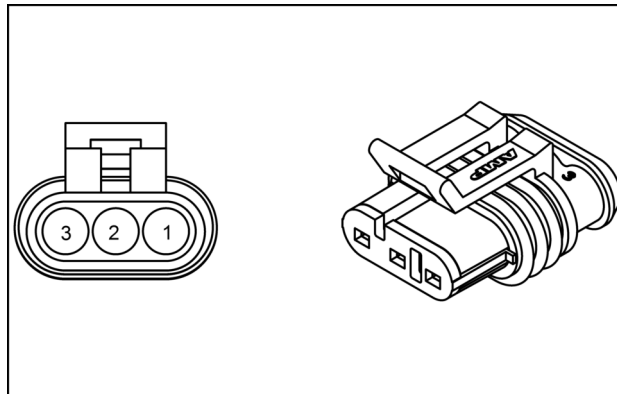

84062580 5

Cavity	Wire ID	Circuit	Cavity	Wire ID	Circuit
(1)	631	Sensor tank level and temp	(3)	608	Sensor tank level and temp
(2)	639-1	Sensor tank level and temp			

**Connector XB-021 – SCR upstream exhaust gas temp sensor**

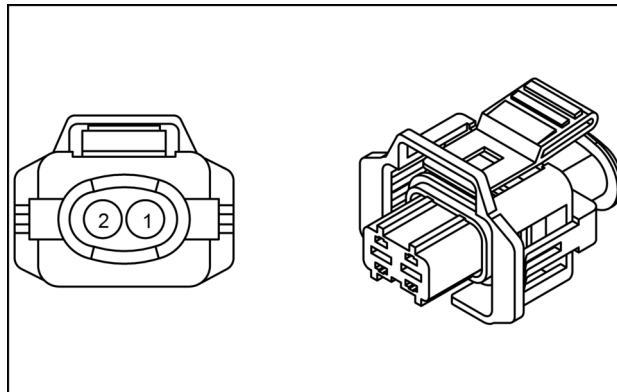

87709793 6

**Connector XY16 – Valve parking brake**

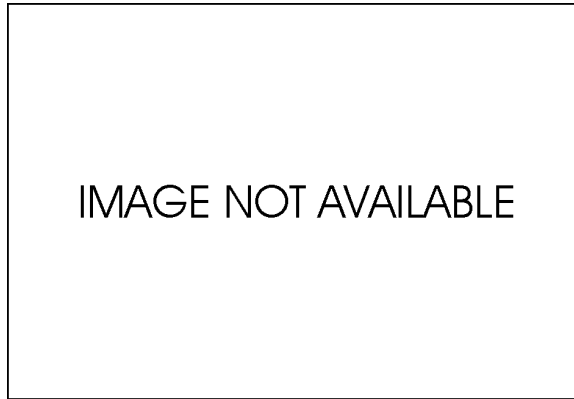

INA 19

Cavity	Wire ID	Circuit	Cavity	Wire ID	Circuit
(1)	341-11	Parking brake	(2)	341-6	Ground

**Connector XY8-5 – Valve FWD forward**

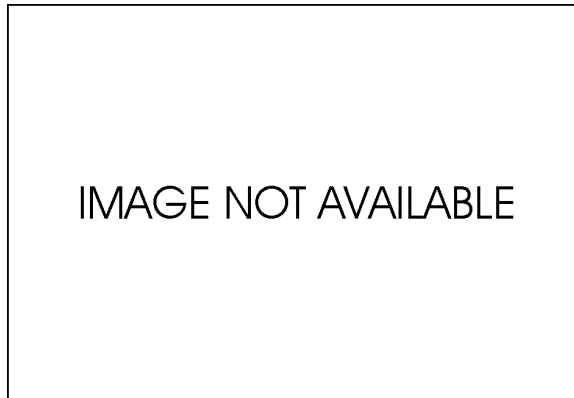

INA 20

Cavity	Wire ID	Circuit	Cavity	Wire ID	Circuit
(1)	314-3	Forward solenoid	(2)	397-31	Forward solenoid

**Connector XY8-6 – Valve FWD reverse**

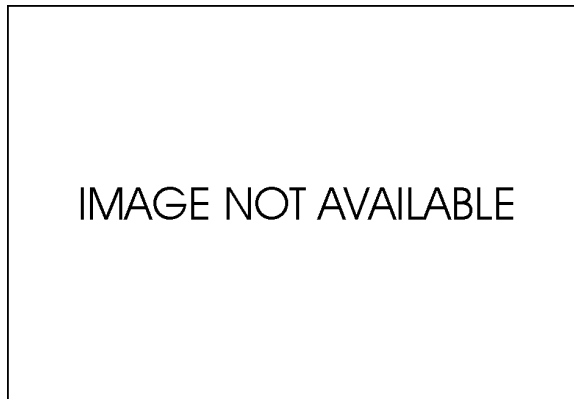

INA 21

Cavity	Wire ID	Circuit	Cavity	Wire ID	Circuit
(1)	315-3	Reverse solenoid	(2)	397-32	Reverse solenoid

**Connector X38-8 – Interface rear frame**

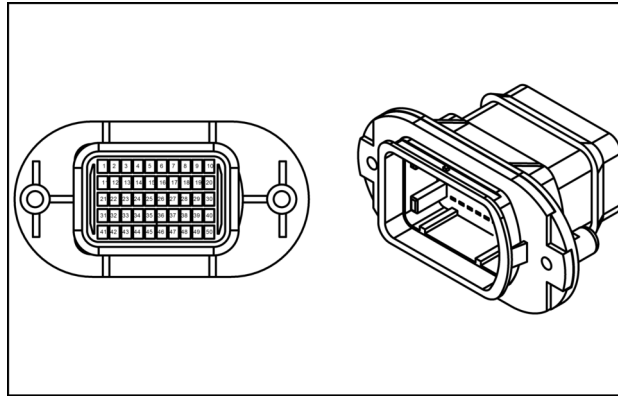

87708534 9

Cavity	Wire ID	Circuit	Cavity	Wire ID	Circuit
(1)	-	-	(14)	382-1	Ground
(2)	-	-	(15)	406-2	Ground
(3)	-	-	(16)	91-2	Interval relay
(4)	1_724-1	Emergency steering	(17)	108-16	Washer front
(5)	-	-	(18)	340-13	Ground
(6)	-	-	(19)	87-11	Reverse light left
(7)	343-4	Fuelling system	(20)	175-22	Brakelights
(8)	343-43	Ground	(21)	78-2	Parking plate tail lights
(9)	347	Engager pin	(22)	84-1	Left turn HI
(10)	347-3	Ground	(23)	340-43	Ground
(11)	348	Rapid working hydraulic	(24)	191-13	Working lights
(12)	348-3	Ground	(25)	191-11	Working lights
(13)	149-2	Back up alarm			

**Connector X3-9-1 – WL cab front left power**

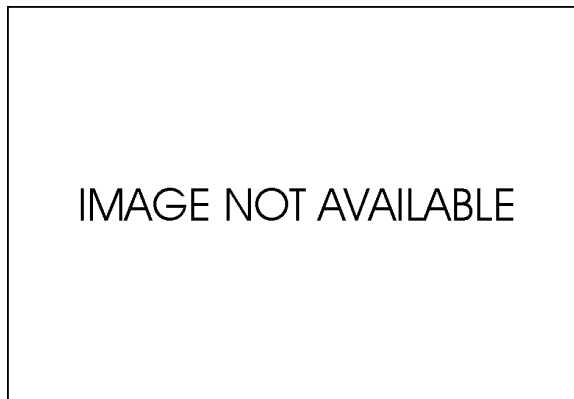

INA 10

Cavity	Wire ID	Circuit	Cavity	Wire ID	Circuit
(1)	192-21	Working lights			

Cavity	Wire ID	Circuit	Cavity	Wire ID	Circuit
(1)	8-1	Flasher cab right			

**Connector X8-2 – RH turn light GND**

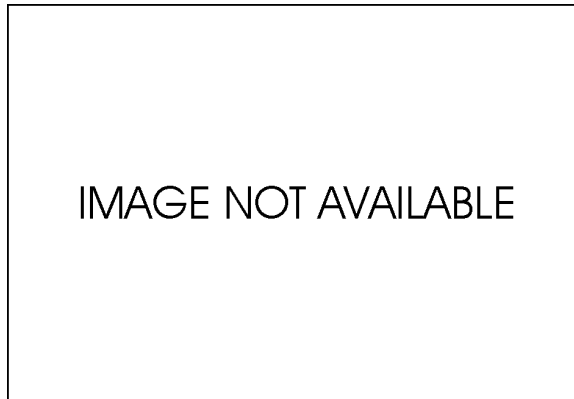

INA 4

Cavity	Wire ID	Circuit	Cavity	Wire ID	Circuit
(1)	8-2	Ground			

**Connector X91-1 – Radio connector**

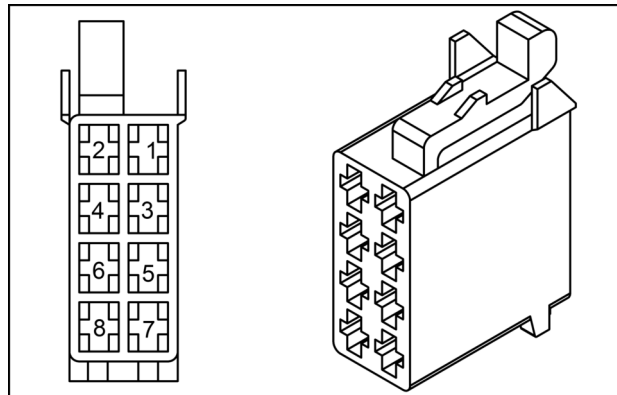

87709660 5

Cavity	Wire ID	Circuit	Cavity	Wire ID	Circuit
(4)	12-71	Radio	(7)	12-7	Radio
(4)	12-72	Radio	(7)	12-71	Radio
(6)	12-72	Radio	(8)	12-5	Radio

**Connector X91-2 – Radio speakers connector**

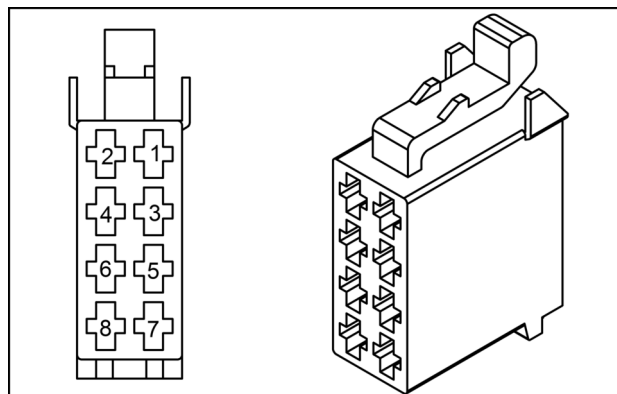

87709371 6

Cavity	Wire ID	Circuit	Cavity	Wire ID	Circuit
(12)	645-3	ENG AUX	(37)	512-32	HVAC
(13)	1_721-3	1K17-85	(38)	512-42	HVAC
(14)	2_701-2	Rear defrost	(39)	408-1	HVAC
(15)	38-1	1K17-30	(40)	213-11	HVAC
(16)	12-31	WL cab roof rear	(41)	213-21	HVAC
(17)	179-2	Ignition 50A	(42)	422	Pre-filter fused
(18)	23	Alternator excite	(43)	-	-
(19)	12-41	WL cab roof front	(44)	144-62	Parking light / head light
(20)	421-1	Relay filter heating hot	(45)	1_704-4	CAN LO
(21)	640	Key switch fused power	(46)	1_703-4	CAN HI
(22)	613	Relay filter heating HI side	(47)	2_703-7	CAN HI
(23)	636	Relay filter heating low side	(48)	2_704-7	CAN LO
(24)	637	Start control relay	(49)	1_703-10	CAN HI
(25)	617	Start control relay low side	(50)	1_704-10	CAN LO

**Connector X104-2 – Connecting block side console**

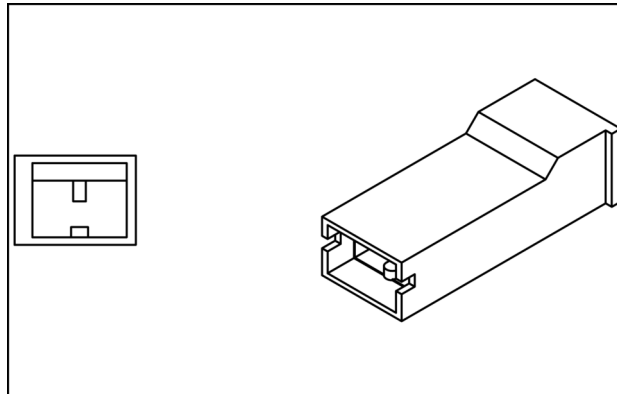

87675193 16

Cavity	Wire ID	Circuit	Cavity	Wire ID	Circuit
(1)	600	EDC fused power			

**Connector X110 – Operators seat**

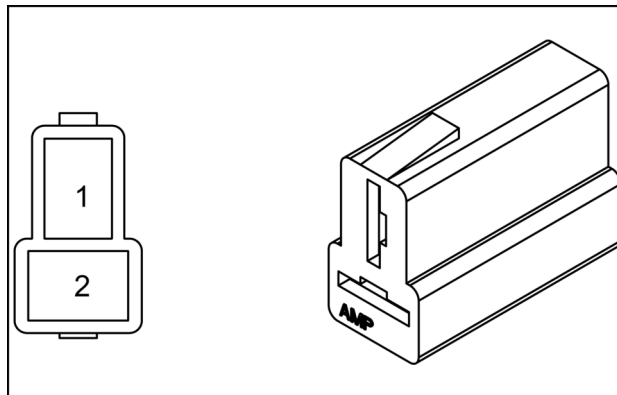

84015523 17

Cavity	Wire ID	Circuit	Cavity	Wire ID	Circuit
(1)	180	Operators seat	(2)	407	Cab ground

Cavity	Wire ID	Circuit	Cavity	Wire ID	Circuit
(9)	108-11	Washer front	(16)	15-3	Ground

**Connector X15 – Interface cab roof**

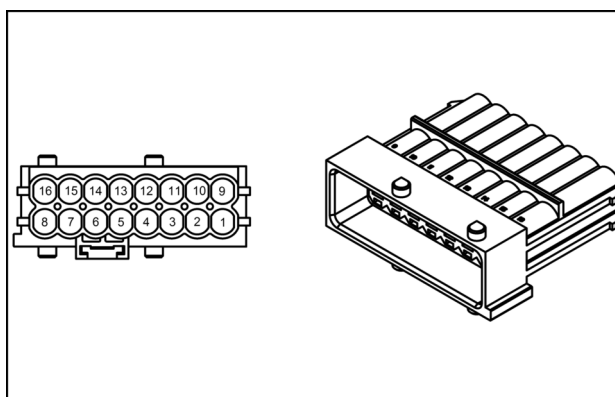

84364852 12

Cavity	Wire ID	Circuit	Cavity	Wire ID	Circuit
(5)	12-33	WL cab roof rear	(9)	108-35	Wiper rear
(6)	12-43	WL cab roof front	(10)	108-37	Wiper washer rear
(7)	2_710-4	Right turn HI	(11)	108-27	Wiper rear
(8)	2_709-4	Left turn HI			

**Connector X21 – Steering column switch**

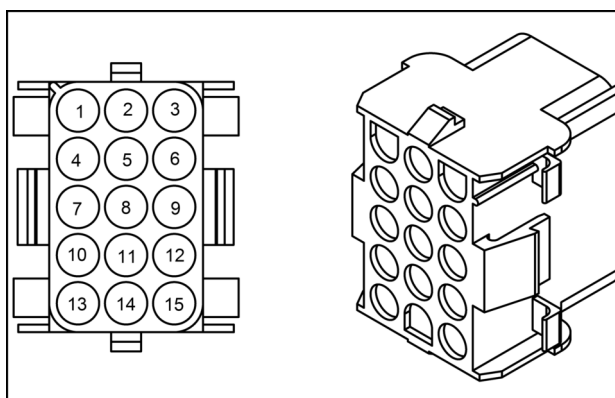

84364841 13

Cavity	Wire ID	Circuit	Cavity	Wire ID	Circuit
(1)	144-6	Parking light / head light	(5)	144-34	Headlight relay
(1)	144-21	Fused horn lights	(6)	144-35	Headlight relay
(2)	2_709-1	Left turn HI	(7)	97-2	Horn relay HI
(3)	2_710-1	Right turn HI	(8)	2_709-6	Flasher relay
(4)	144-33	Parking / head light			

**Connector XE1-56A – Left HI beam**

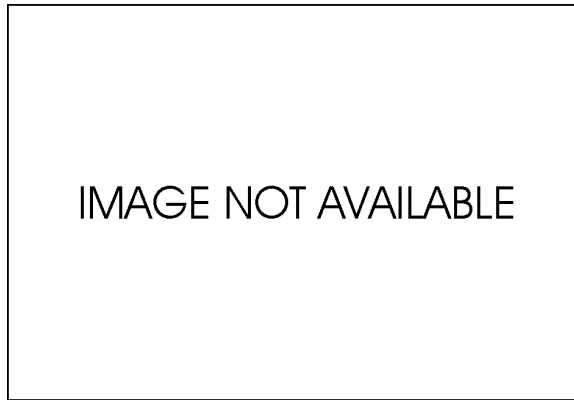

INA 3

Cavity	Wire ID	Circuit	Cavity	Wire ID	Circuit
(1)	187-22	Headlight			

**Connector XE1-56B – Left LO beam**

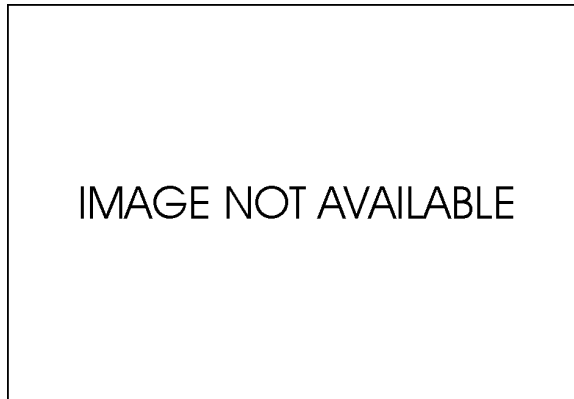

INA 4

Cavity	Wire ID	Circuit	Cavity	Wire ID	Circuit
(1)	186-22	Headlight			

**Connector XE1-E2-1 – Parking light left**

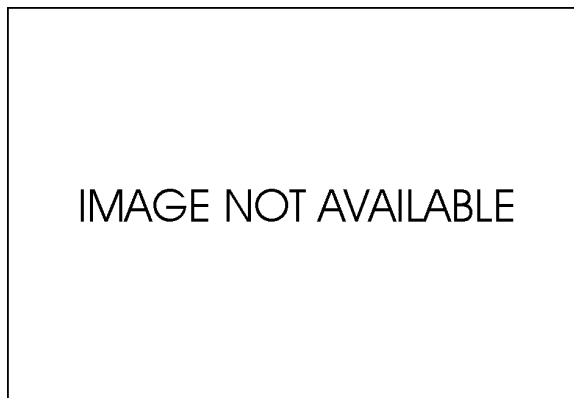

INA 5

Cavity	Wire ID	Circuit	Cavity	Wire ID	Circuit
(1)	78-32	Parking plate tail lights			

**Connector X4-8-2 – WL rear frame right GND**

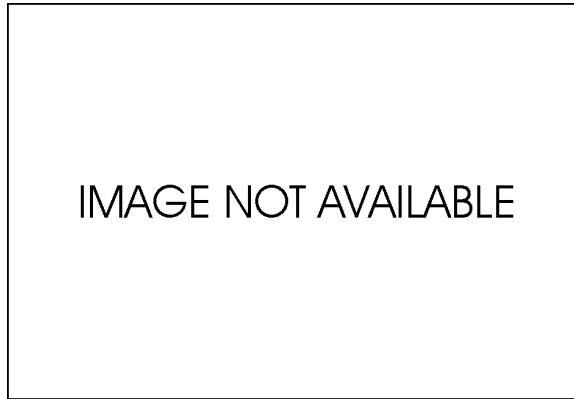

INA 12

Cavity	Wire ID	Circuit	Cavity	Wire ID	Circuit
(1)	340-34	Ground			

**Connector XM4 – Washer front**

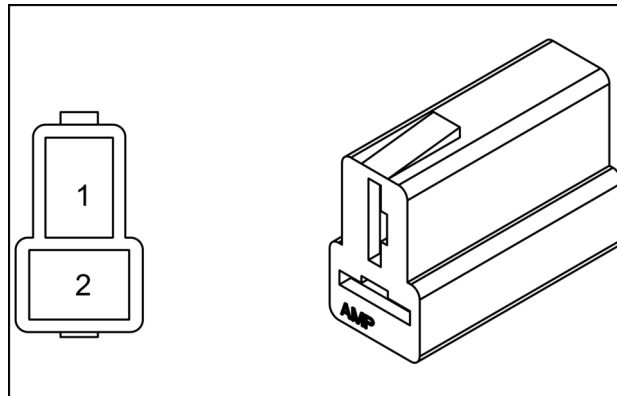

84015523 13

Cavity	Wire ID	Circuit	Cavity	Wire ID	Circuit
(1)	108-17	Washer front	(2)	406-1	Washer front
(2)	406	Ground			

**Connector XM4-1 – Washer rear**

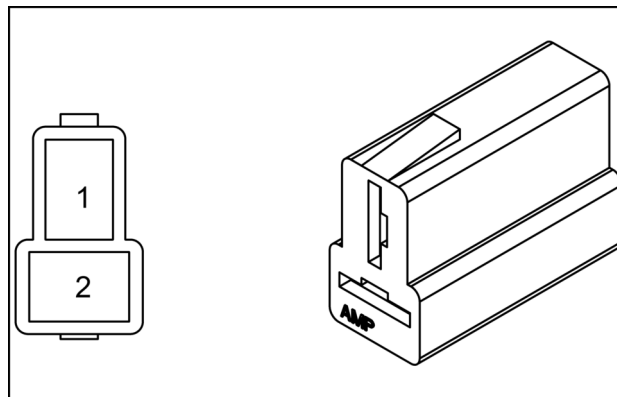

84015523 14

Cavity	Wire ID	Circuit	Cavity	Wire ID	Circuit
(1)	91-3	Interval relay	(2)	406-1	Washer front

**Connector XS67 – Fuelling system**

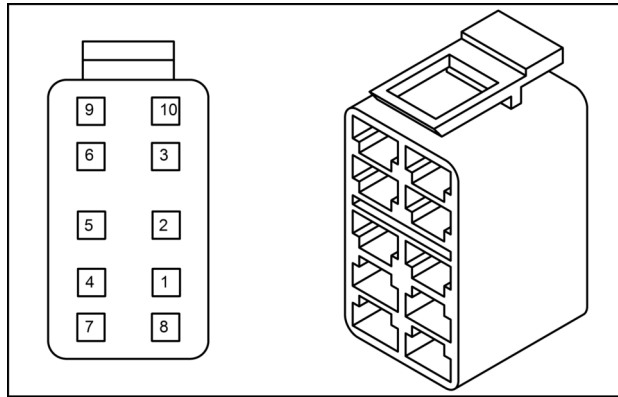

87716755 10

Cavity	Wire ID	Circuit	Cavity	Wire ID	Circuit
(2)	507-31	Fuelling system	(7)	405	Cab ground
(2)	508	Fuelling system	(8)	393-10	Beacon
(3)	2_716-3	Fuelling system	(8)	393-11	Transmission neutral

**Connector XS77-1 – Working lights cab front / rear**

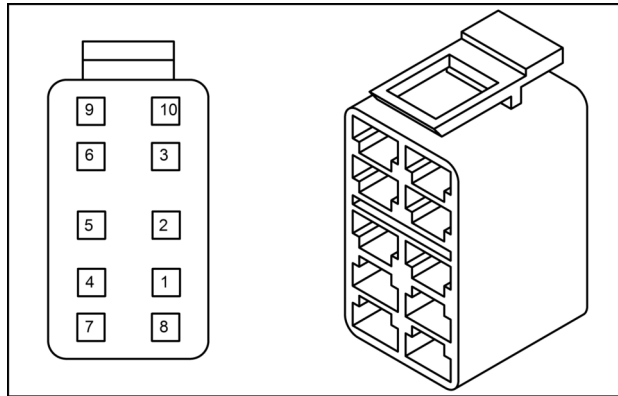

87716755 11

Cavity	Wire ID	Circuit	Cavity	Wire ID	Circuit
(2)	12-2	Working lights cab roof	(6)	12-3	WL cab roof rear
(3)	12-4	WL cab roof front	(7)	12-6	Cab ground
(5)	12-1	Working lights relay power	(8)	393-6	Working lights cab roof
(5)	12-2	Working lights cab roof	(8)	393-7	Working lights cab roof

**Connector XS77-2 – Working lights cab front below**

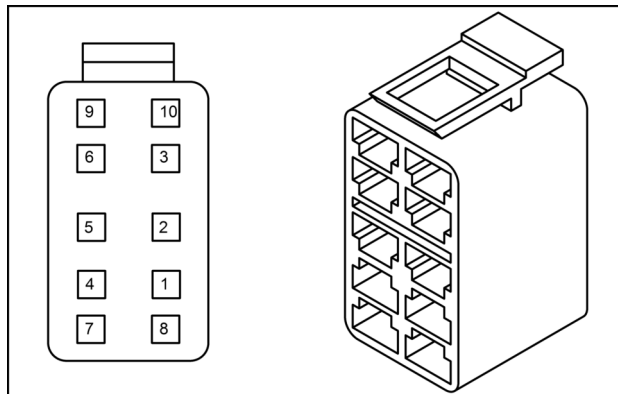

87716755 12

Electrical systems - Harnesses and connectors

<b>Cavity</b>	<b>Wire ID</b>	<b>Circuit</b>	<b>Cavity</b>	<b>Wire ID</b>	<b>Circuit</b>
(1)	8761370 6	Side console ground			

**Fuse/relay box 1F/1K**

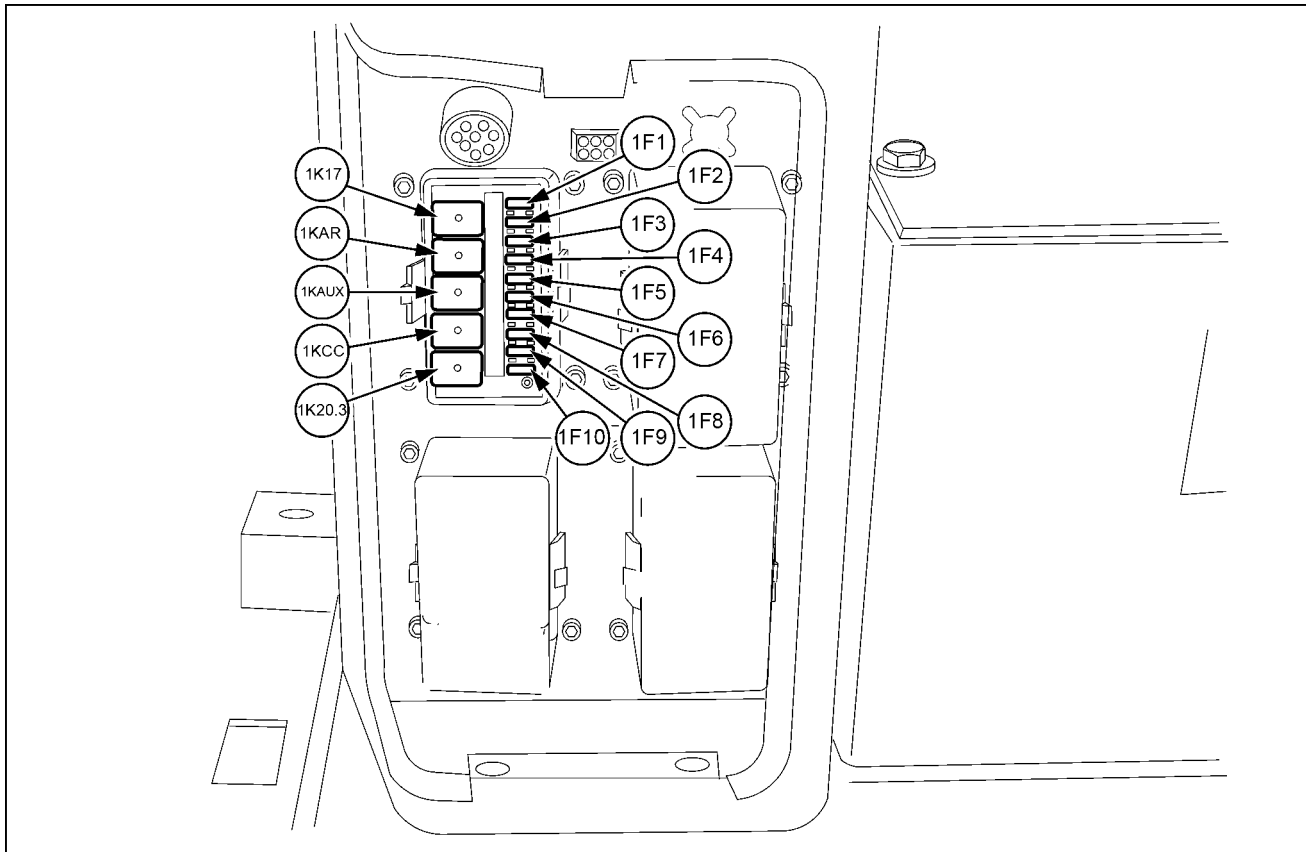

SS14J022 2

Fuse/relay designation	Amperes	Color code	Consumer
1F1	10 A	Red	AIC power supply
1F2	30 A	Green	EDC power supply
1F3	5 A	Beige	Starter switch S1 to EDC
1F4	2 A	Beige	Power Relay K10.1, UCM Ignition ON
1F5	20 A	Yellow	Filter heater
1F6	15 A	Red	Voltage transformer, radio, power outlet
1F7	7.5 A	Brown	Interior cab light, Power supply rear camera
1F8	7.5 A	Brown	Starter switch S1, starter relay K1.5, Crank signal UCM
1F9	5 A	Beige	Alternator
1F10	5 A	Beige	Diagnosis socket X123, relay 3K116
1K AR IGN PWR			After Run Ignition Power
1KAUX			Auxiliary relay EDC
1K17			Relay Defrost
1KCC			Relay start control
1K20.3			Relay filter heater



## **Electrical systems - 55**

### **Selective Catalytic Reduction (SCR) electrical system - 988**

**F106.8A**  
**F106.8**  
**F156.8A**  
**F156.8**

## Diesel Exhaust Fluid (DEF)/AdBlue® dosing module Dosing valve - Remove

F106.8A	WE
F106.8	WE
F156.8A	WE
F156.8	WE

**NOTICE:** Emissions sensors in the exhaust system and on the vehicle may be damaged by vibrations from use of impact wrenches or hammers during service work. Avoid using these tools when servicing components close to the sensors. Remove the sensors with care if use of these tools cannot be avoided.

1. Open the hood (1).

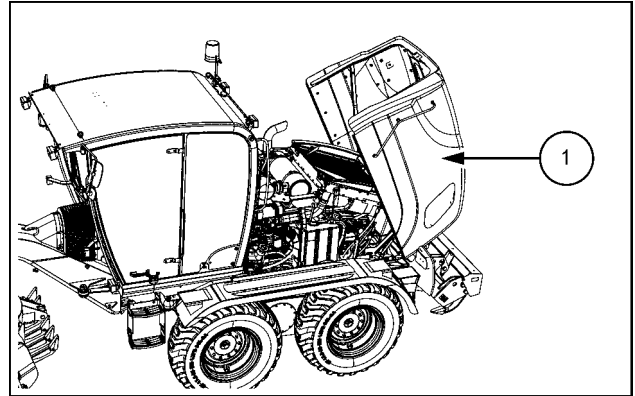

SS14K018 1

2. Clean dirt and debris from the Diesel Oxidation Catalyst (DOC) connections and DEF/AdBlue® dosing valve.

**NOTE:** The dosing valve is located in the Diesel Oxidation Catalyst (DOC).

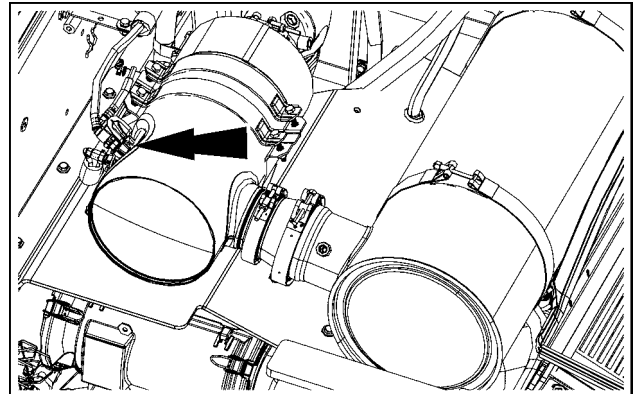

SS14K049 2

3. Mark the location of the supply and return lines for reference during reassembly. Disconnect the dosing valve wiring harness (1), the cooling water lines (2) and the inlet DEF/AdBlue® line (3). Cap the lines to prevent entering of debris in the system. Remove the bolts that secure the dosing valve (4) into Diesel Oxidation Catalyst (DOC). Remove the dosing valve (4). Cover opening of the Diesel Oxidation Catalyst (DOC) to prevent the entering of debris in the exhaust system.

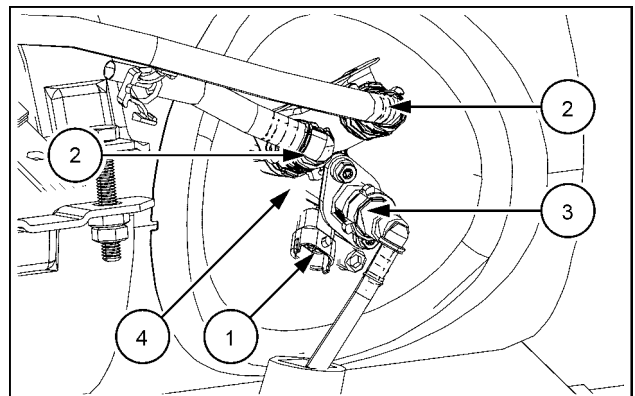

SS14K050 3

**NOTE:** To separate connections, squirt water into fittings to lubricate O-rings. Squeeze fitting locking tabs slightly and push fitting together then pull it apart. If fitting will not release, but is free to rotate, the O-ring is likely stuck and additional water should be applied.

## Nitrogen Oxides (NOx) sensor - Install – Catalyst outlet Nitrogen Oxides (NOx) sensor

F106.8A	WE
F106.8	WE
F156.8A	WE
F156.8	WE

**NOTICE:** Emissions sensors in the exhaust system and on the vehicle may be damaged by vibrations from use of impact wrenches or hammers during service work. Avoid using these tools when servicing components close to the sensors. Remove the sensors with care if use of these tools cannot be avoided.

1. Install the NOx sensor (1) into the inlet of the Selective Catalytic Reduction (SCR).

**NOTICE:** Grease the sensor with **WEICON HIGH-TECH ASSEMBLY PASTE**.

2. Secure the NOx sensor with the hexagonal nut.  
Torque to . **40 - 60 N·m (30 - 44 lb ft)**.

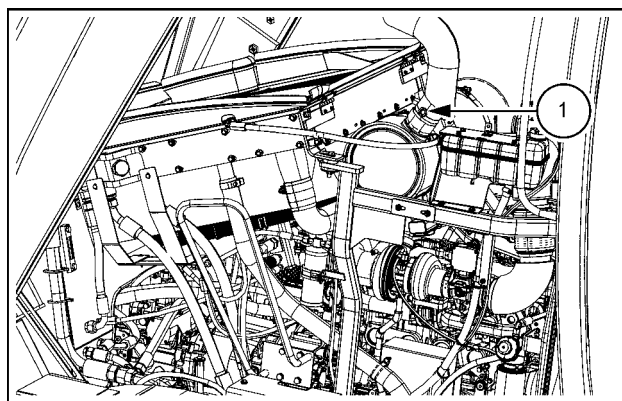

SS14K029 1

## Exhaust Gas Recirculation (EGR) temperature sensors Diesel Oxidation Catalyst (DOC) inlet temperature sensor - Install

F106.8A	WE
F106.8	WE
F156.8A	WE
F156.8	WE

**NOTICE:** Emissions sensors in the exhaust system and on the vehicle may be damaged by vibrations from use of impact wrenches or hammers during service work. Avoid using these tools when servicing components close to the sensors. Remove the sensors with care if use of these tools cannot be avoided.

1. Install temperature sensor **(1)** into exhaust system. Secure sensor by tightening hex nut with a torque from **40 - 50 N·m (30 - 37 lb ft)**.
2. Reconnect sensor **(1)** to machine wiring harness. Install any wire ties that secure the sensor wiring harness to the machine.

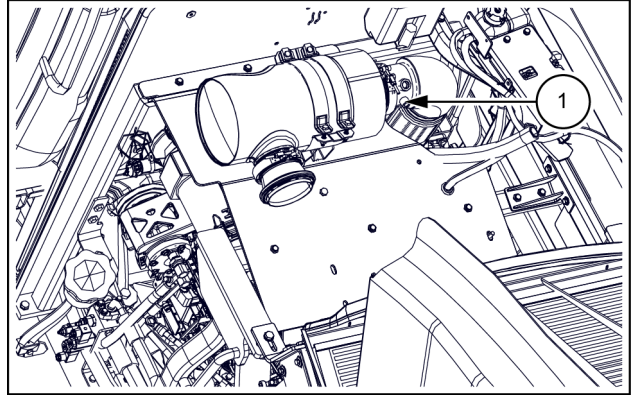

SS14K057 1

Electrical systems - Electronic modules

Code	Severity	Allocate	Description
3767	Yellow	NEF	ECU internal failure - 'WDA active' reported due to errors in query/response communication
3768	Yellow	NEF	ECU internal failure - 'ABE active' reported due to undervoltage detection
3769	Yellow	NEF	ECU internal failure - 'ABE active' reported due to overvoltage detection
3770	Yellow	NEF	ECU internal failure - 'WDA/ABE active' reported
3771	Yellow	NEF	Up and down stream temperature sensors in Oxidation catalyts exchanged
3773	Yellow	NEF	Under boost detected in Pressure charger regulator
3775	Yellow	NEF	Monitoring of the characteristic pressure reduction of the particulate filter - max
3794	Yellow	NEF	Plausibility Check for air pressure at the upstream of intake valve sensor
3795	Yellow	NEF	Plausibility Check for air pressure at the upstream of intake valve sensor
3799	Yellow	NEF	Fuel pressure relief valve is forced to open, perform pressure shock
3805	Red	NEF	Maximum rail pressure exceeded
3808	Red	NEF	High pressure pump fuel delivery quantity at low idle is too high
3810	Yellow	NEF	Rail pressure sensor value is intermittent
3811	Yellow	NEF	ECU internal failure - Sensor 5 volt supply 1
3812	Yellow	NEF	ECU temperature sensor 1 is too high
3813	Yellow	NEF	ECU temperature sensor 1 is too low
3814	Yellow	NEF	ECU temperature sensor error detected
3836	Yellow	NEF	Downstream oxidation catalyst temperature sensor voltage is lower than expected
3837	Yellow	NEF	Upstream oxidation catalyst temperature plausibility failure
3838	Yellow	NEF	Upstream oxidation catalyst temperature sensor voltage is lower than expected
3857	Yellow	NEF	Turbine over speed failure
3858	Yellow	NEF	CAN communication error between ECU and eVGT actuator
3861	Yellow	NEF	eVGT power supply electrical failure
3865	Yellow	NEF	eVGT system failure
3868	Yellow	NEF	eVGT actuator over temperature error
3870	Yellow	NEF	CAN communication failure between vehicle controller and ECU - BC2ECU1 message
3877	Yellow	NEF	Supply UB1 short circuit to battery failure
3878	Yellow	NEF	Supply UB2 short circuit to battery failure
3879	Yellow	NEF	Supply UB3 short circuit to battery failure
3880	Yellow	NEF	Actuator relay 3 circuit short to battery failure
3881	Yellow	NEF	Supply UB1 short circuit to battery failure
3882	Yellow	NEF	Supply UB2 short circuit to battery failure
3883	Yellow	NEF	Supply UB3 short circuit to battery failure
3884	Yellow	NEF	Physical Range Check high for Engine coolant temperature (down stream)
3897	Yellow	NEF	Engine compression brake low side ECU driver circuit over temperature failure
3903	Yellow	NEF	Fuel temperature is too high
3904	Yellow	NEF	Fuel temperature plausibility check failed
3905	Yellow	NEF	Intake air heater ECU driver has an over-temperature error
3906	Yellow	NEF	Number of injections is limited by quantity balance of high pressure pump
3909	Yellow	NEF	Crankcase pressure too high
3910	Red	NEF	Fuel metering unit intermittent electrical connection failure
3911	Yellow	NEF	Fuel metering unit is shorted to battery voltage at the high side
3912	Yellow	NEF	Fuel metering unit is shorted to ground at the high side
3913	Yellow	NEF	The calculated conversion rate is smaller as the limiting value
3915	Yellow	NEF	Averaged rail pressure is outside the expected tolerance range
3916	Yellow	NEF	Fuel pressure relief valve has reached maximum allowed open time
3930	Yellow	NEF	SCR inducement warning due to distance/time is active - Level 10
3933	Yellow	NEF	SCR inducement warning due to distance/time is active - Level 6
3936	Yellow	NEF	ECU internal: Error Sensor supplies Voltage Tracker
3961	Yellow	NEF	CAN communication failure - External torque/speed checksum and counter
3962	Yellow	NEF	Crankcase pressure too high for too long
3963	Yellow	NEF	Crankcase pressure too high and oil pressure too low - Fuel in oil suspected
3964	Yellow	NEF	ECU temperature sensor 2 is too high

Electrical systems - Electronic modules

Code	Severity	Allocate	Description
19704	Yellow	NEF	Diagnostic Fault Check for Supply Module Heater Temperature Duty cycle in invalid range
19705	Yellow	NEF	Minimum rail pressure failed
19706	Yellow	NEF	Maximum rail pressure exceeded
19707	Yellow	NEF	-
19708	Yellow	NEF	Monitoring for pressure loss in the high pressure accumulator (rail test)
19709	Yellow	NEF	maximum negative rail pressure deviation with metering unit on lower limit is exceeded (second stage)
19710	Yellow	NEF	maximum rail pressure exceeded (second stage)
19711	Yellow	NEF	positive deviation of rail pressure under fast condition exceeded
19713	Yellow	NEF	maximum rail pressure exceeded - overrun detection
19714	Yellow	NEF	maximum positive deviation of rail pressure exceeded for tank lo detection
19715	Yellow	NEF	maximum positive deviation of rail pressure exceeded concerning set flow of fuel for tank lo detection
19716	Yellow	NEF	leakage is detected based on fuel quantity balance (tank low condition)
19717	Yellow	NEF	maximum negative rail pressure deviation with metering unit on lower limit is exceeded
19718	Yellow	NEF	maximum negative rail pressure deviation with metering unit on lower limit is exceeded (second stage)
19719	Yellow	NEF	minimum rail pressure exceeded for tank lo detection
19720	Yellow	NEF	Maximum rail pressure exceeded
19726	Yellow	NEF	maximum rail pressure exceeded (second stage)
19727	Yellow	NEF	positive deviation of rail pressure under fast condition exceeded for tank lo detection
19728	Yellow	NEF	setpoint of metering unit in overrun mode not plausible
19729	Yellow	NEF	setpoint of metering unit in idle mode not plausible (tank low condition)
19731	Yellow	NEF	maximum rail pressure exceeded - overrun detection
19732	Yellow	NEF	maximum positive deviation of rail pressure exceeded
19733	Yellow	NEF	maximum positive deviation of rail pressure exceeded concerning set value PCV
19734	Yellow	NEF	maximum negative rail pressure deviation with closed pressure control valve exceeded
19735	Yellow	NEF	maximum negative rail pressure deviation with closed pressure control valve exceeded (second stage)
19736	Yellow	NEF	minimum rail pressure exceeded
19737	Yellow	NEF	maximum rail pressure exceeded
19738	Yellow	NEF	maximum rail pressure exceeded (second stage)
19743	Yellow	NEF	maximum positive deviation of rail pressure exceeded
19744	Yellow	NEF	maximum positive deviation of rail pressure exceeded concerning set value PCV
19745	Yellow	NEF	maximum negative rail pressure deviation with closed pressure control valve exceeded
19746	Yellow	NEF	maximum negative rail pressure deviation with closed pressure control valve exceeded (second stage)
19747	Yellow	NEF	minimum rail pressure exceeded
19748	Yellow	NEF	DEF/AdBlue supply module pump motor ECU driver over temperature failure
19750	Yellow	NEF	maximum rail pressure exceeded
19751	Yellow	NEF	maximum rail pressure exceeded (second stage)
19752	Yellow	NEF	maximum rail pressure exceeded
19753	Yellow	NEF	Ratio between DEF/AdBlue PumpSpeed and Dosing Valve exceeded
19754	Yellow	NEF	Ratio between DEF/AdBlue PumpSpeed and Dosing Valve exceeded
19755	Yellow	NEF	Ratio between DEF/AdBlue PumpSpeed and Dosing Valve exceeded
19756	Yellow	NEF	Ratio between DEF/AdBlue PumpSpeed and Dosing Valve exceeded
19758	Yellow	NEF	Ratio between DEF/AdBlue PumpSpeed and Dosing Valve exceeded
19759	Yellow	NEF	Warning for level of reducing agent stage 4
19760	Yellow	NEF	-
19761	Yellow	NEF	Value of the remaining SCR distance within the info range
19762	Yellow	NEF	Value of the remaining SCR distance within warning stage 1

## Instrument cluster - Component identification

F106.8A	WE
F106.8	WE
F156.8A	WE
F156.8	WE

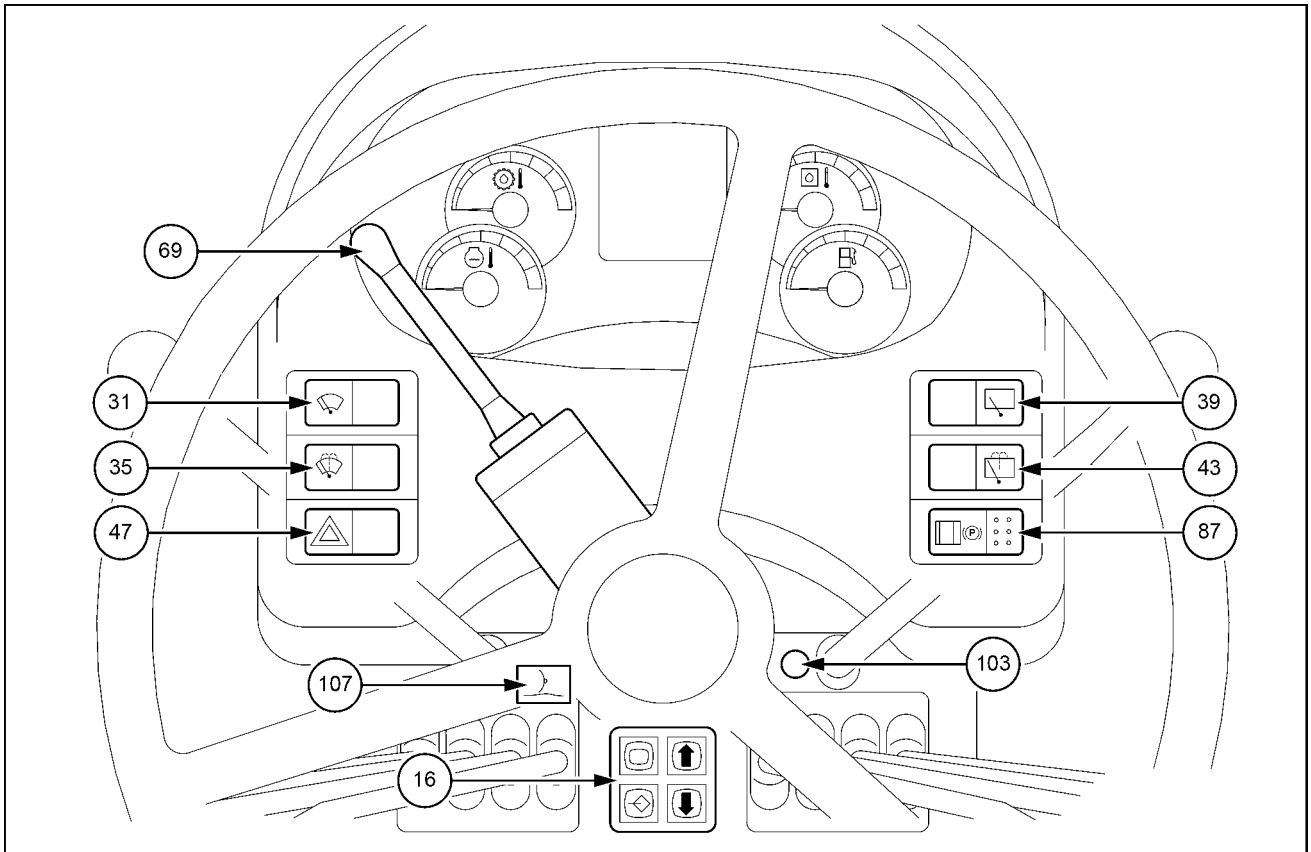

SS14D039 1

Pos.	Designation	Function	Symbol
16	Keypad	Navigation keys for multi-function display	
31	Switch	Windshield wiper, front window	
35	Pushbutton	Windshield washer, front window	
39	Switch	Windshield wiper, rear window	
43	Pushbutton	Windshield washer, rear window	
47	Switch	Hazard warning system	
69	Steering-column lever switch	Lighting	Turn signal, horn, headlamp flasher, high beam

# Contents

---

## Electrical systems - 55

### Warning indicators, alarms, and instruments - 408

#### FUNCTIONAL DATA

Warning indicators, alarms, and instruments	
Component identification (*) .....	3
Identification – View fault codes (*) .....	4

#### SERVICE

Warning indicators, alarms, and instruments	
Service instruction – Clear fault memory (*) .....	7

(\*) See content for specific models

---

## Dozer blade - General specification

F106.8A	WE
F106.8	WE
F156.8A	WE
F156.8	WE

<b>Designation</b>	<b>F106.8/F106.8A</b>	<b>F156.8/F156.8A</b>
Plate width	<b>2350 mm (92.5 in)</b>	<b>2450 mm (96.5 in)</b>
Plate height	<b>765 mm (30.1 in)</b>	<b>870 mm (34.3 in)</b>
Scraping depth	<b>136.0 mm (5.4 in)</b>	<b>183.0 mm (7.2 in)</b>
Max. ground clearance	<b>509.0 mm (20.0 in)</b>	<b>547.0 mm (21.5 in)</b>

5. Bring the light bar (6) into position and fasten it to the front frame using the two top screws (5) and hexagon nuts (4).

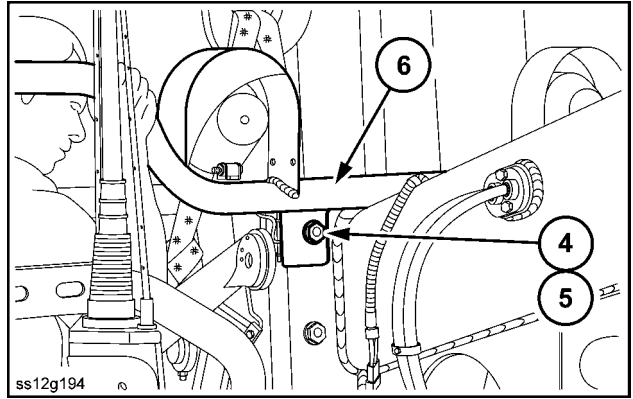

6. Tighten the bolts with **540 N·m (398 lb ft)**.

7. Attach the connector (X68) of the light bar wiring and fasten the cable with cable tie.
8. Mount the cover (3) at the top of the front frame.

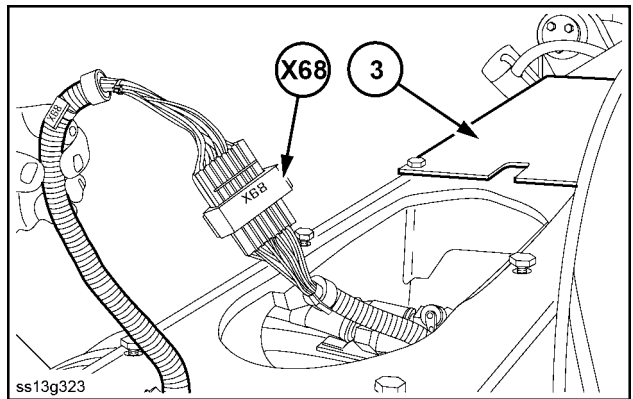

9. Remove the stop plugs from the hydraulic cylinder connections.
10. Untie the hydraulic lines (9) and (10) and connect them to the hydraulic cylinder.
11. Open the ball valve (1).

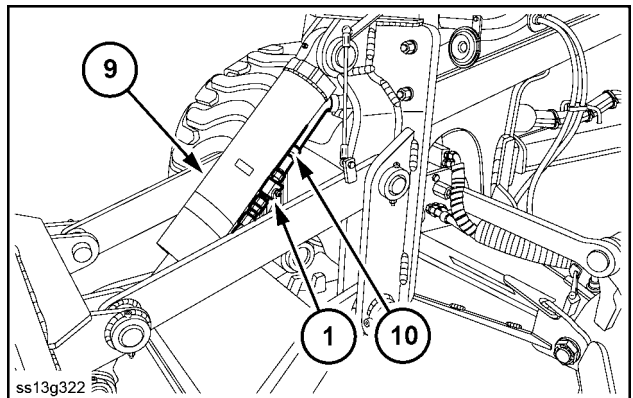

12. Insert the ball head of the check rod for the dozer plate position indicator in the mounting link, and fasten it with the hexagon nut (2).
13. Lower the lifting gear and remove any lifting accessories.
14. Start the engine and move the dozer plate several times to the top and bottom end positions, in order to vent the hydraulic cylinders.

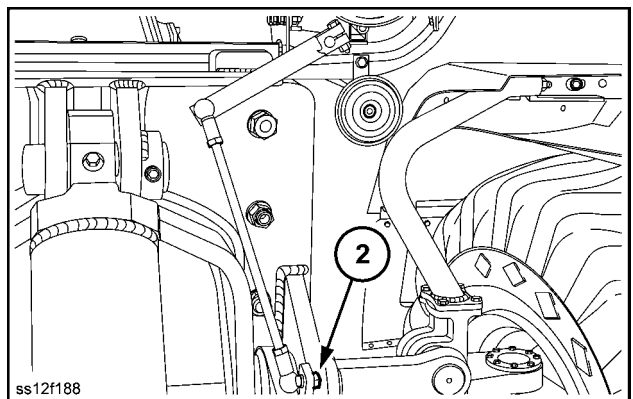

11. Secure the lift cylinder with lifting gear.
12. Remove the 4 screws (8) and take out the swing cylinder.

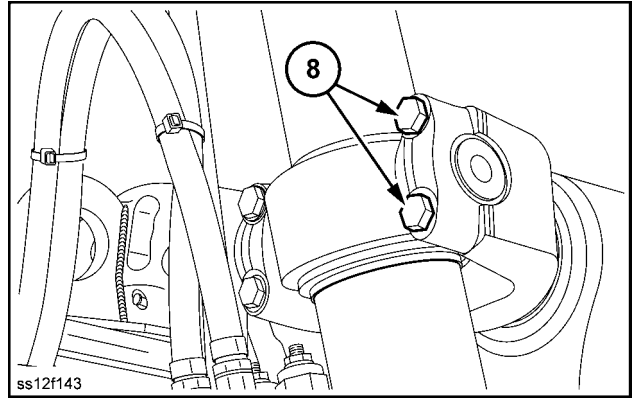

SS12F143 7

13. Remove the 4 mounting screws of the cap (9) and take off the cap (9).
14. Pull out the lift cylinder yoke (10) and the swivel cylinder yoke (11) and put the bushings (12) aside.

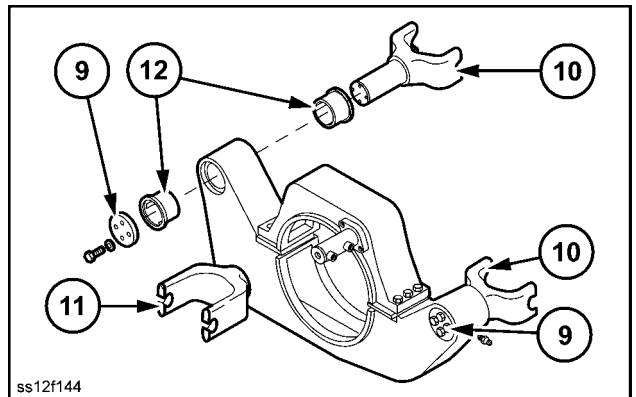

SS12F144 8

15. Detach the hydraulic lines (234) and (235) at the detent pin (13) that locks the saddle.

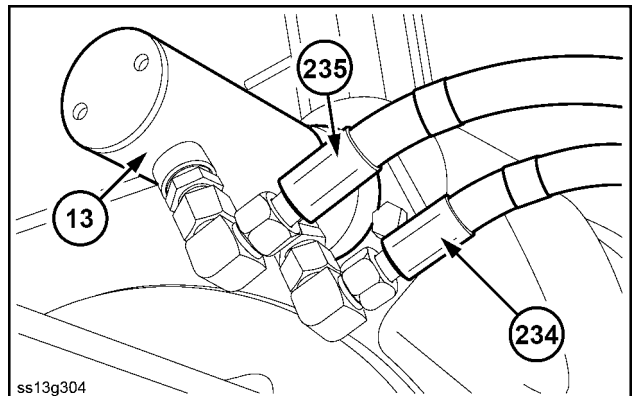

SS13G304 9

16. Loosen the two screws and take out the detent pin (13).
17. Secure both parts of the saddle with lifting gear and take out the six screws (14).
18. Take off the saddle upper section (15) and take off the shims (16). Remove the screws and take off shim (17) and bushing (18).
19. Lower the saddle lower section (19).

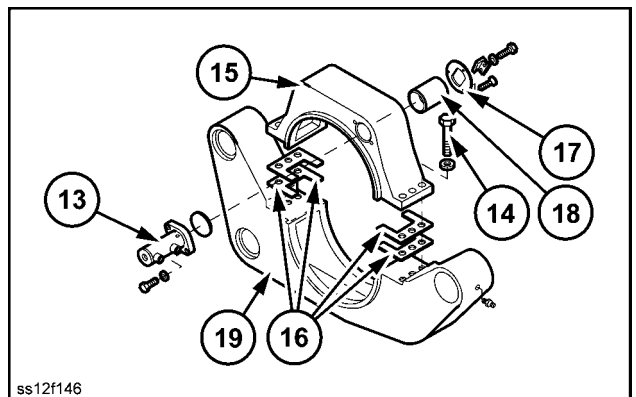

SS12F146 10

**Next operation:**  
**Moldboard blade - Install (86.112).**  
 or

32. **⚠ WARNING**

**Avoid injury!**  
**To prevent frostbite, always wear gloves when you handle frozen parts.**  
**Failure to comply could result in death or serious injury.**

W1218A

Insert the pins (21) after chilling to **-55 °C (-67.0 °F)**.

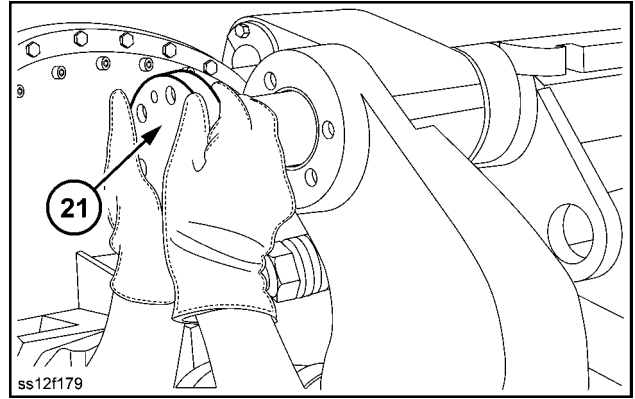

SS12F179 15

33. Fasten the screws of the pin (21) for the blade mounting (11) to the circle (22).

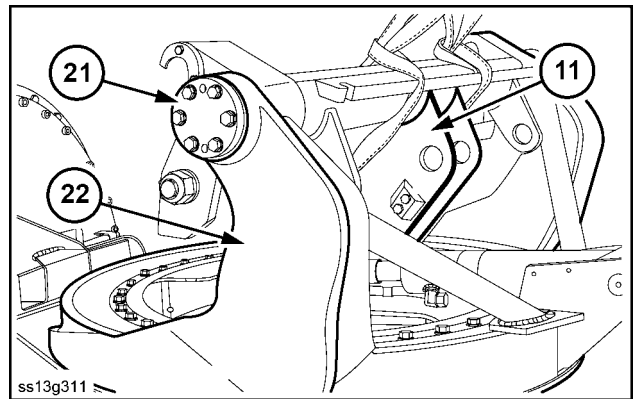

SS13G311 16

34. For the optional ripper, secure the ripper teeth (20) to the ripper (14) with the cotter pins (19).

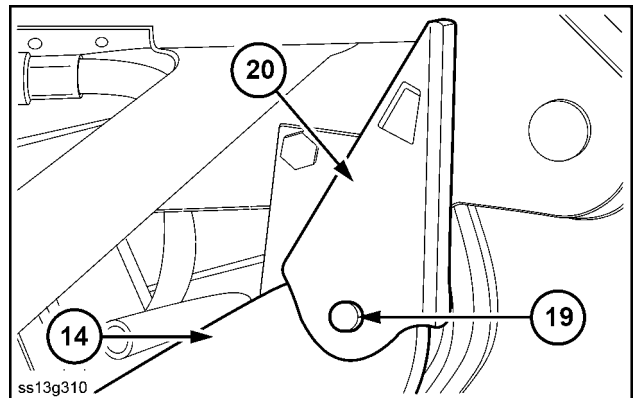

SS13G310 17

35. Turn the blade mounting (11).

36. Insert the pin (17), the spacers (18), and the ripper (14).

37. Knock the cotter pin (16) into the pin.

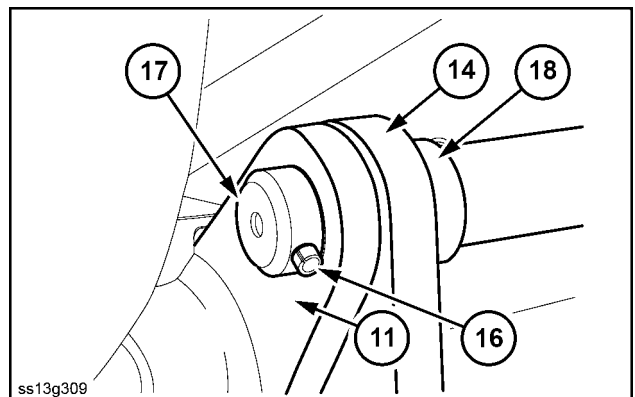

SS13G309 18



## **Tools - 89**

### **Ripper assembly - 128**

**F106.8A**  
**F106.8**  
**F156.8A**  
**F156.8**

## Ripper assembly - Install

F106.8A	WE
F106.8	WE
F156.8A	WE
F156.8	WE

### ⚠ WARNING

**Heavy objects!**

**Lift and handle all heavy components using lifting equipment with adequate capacity. Always support units or parts with suitable slings or hooks. Make sure the work area is clear of all bystanders.**

**Failure to comply could result in death or serious injury.**

W0398A

### ⚠ CAUTION

**Pinch hazard!**

**Always use suitable tools to align mating parts. DO NOT use your hand or fingers.**

**Failure to comply could result in minor or moderate injury.**

C0044A

**NOTE:** Refer also to *Ripper assembly - Component identification (89.128)*.

1. Raise the rear of the grader and place it on a suitable support frame so that the tandem drive swings out and the bolt can be mounted.

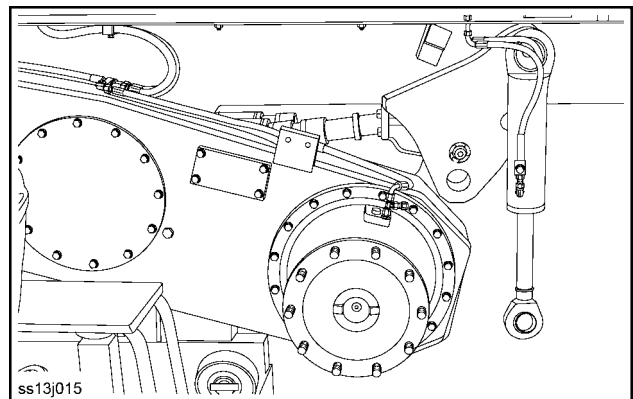

SS13J015 1

2. Lift the rear ripper with lifting gear and bring the holes into line.
3. Insert the bolt (3).

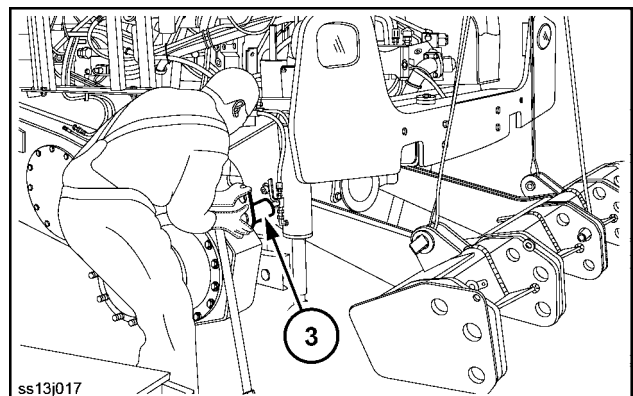

SS13J017 2

16. Unscrew the six hexagon nuts (17) (three on each side) and two hexagon nuts (18) (front left and right) and remove the washers (20).
17. Unscrew the four hexagon-head bolts (19) (two on each side).

**NOTE:** The two rear hexagon nuts (left and right) are located in the cab.

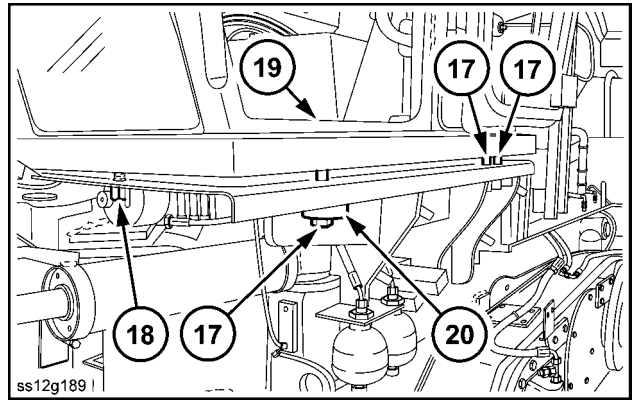

SS12G189 12

**NOTICE:** When lifting the cab, take care with the two cables (5) and hoses (11) for the windshield washer system, particularly when pulling them through the cab floor.

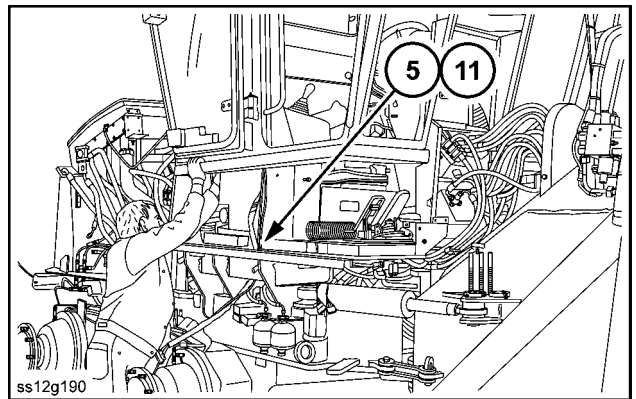

SS12G190 13

3. Bring the cab floor over the frame and hold the hydraulic and the electrical lines aside.

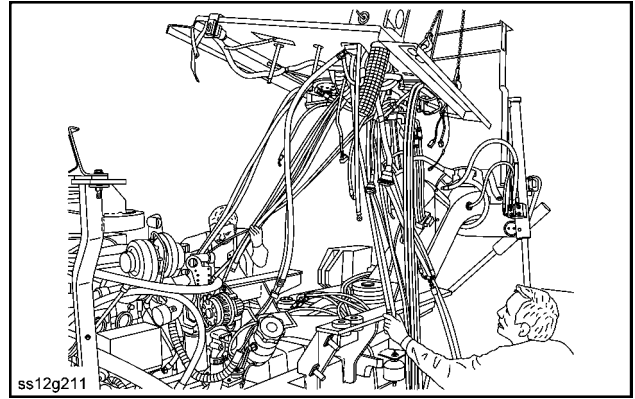

SS12G211 2

4. Lower the cab floor (19) so that access is still possible to the underside.

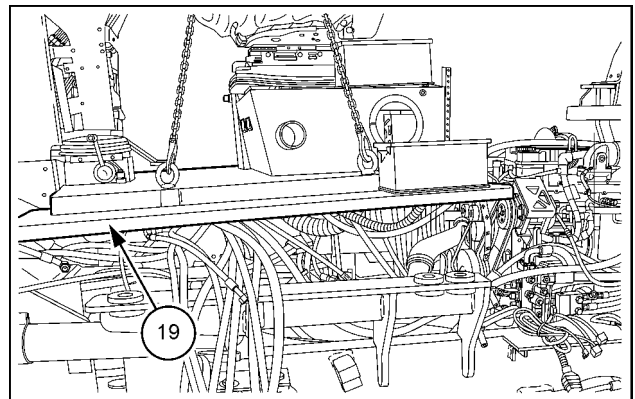

SS14H007 3

5. Lay out the hydraulic lines (254) and (255) (steering cylinders to steering servo) along the existing hose bundle to the steering servo.
6. Check that they are free of tension and that there are no kinks.

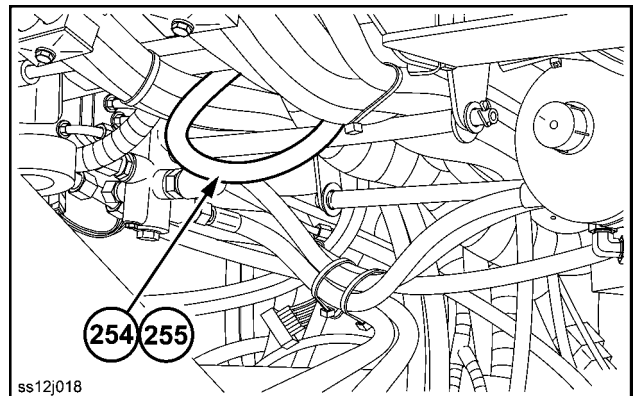

SS12J018 4

7. Lower the cab floor further and align it with the holes in the frame using mounting bolts and/or an assembly lever.

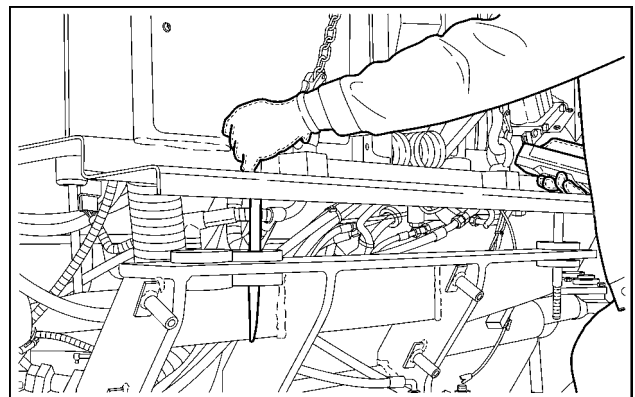

SS14H008 5

# Index

---

## Platform, cab, bodywork, and decals - 90

### Mechanically-adjusted operator seat - 120

Mechanically-adjusted operator seat - Install (*) .....	4
Mechanically-adjusted operator seat - Remove (*) .....	3

(\*) See content for specific models

CLICK HERE TO **DOWNLOAD** THE COMPLETE MANUAL

- Thank you very much for reading the preview of the manual.
- You can download the complete manual from: [www.heydownloads.com](http://www.heydownloads.com) by clicking the link below



- Please note: If there is no response to CLICKING the link, please download this PDF first and then click on it.

CLICK HERE TO **DOWNLOAD** THE COMPLETE MANUAL