

SERVICE MANUAL

E27B

Tier 3

Compact Hydraulic Excavator

PIN NETN27001 and above

Part number S5HD0003E01

1st edition English
October 2014



CLICK HERE TO **DOWNLOAD** THE COMPLETE MANUAL

- Thank you very much for reading the preview of the manual.
- You can download the complete manual from: www.heydownloads.com by clicking the link below



- Please note: If there is no response to CLICKING the link, please download this PDF first and then click on it.

CLICK HERE TO **DOWNLOAD** THE COMPLETE MANUAL

[1. OUTLINE]

- (7) Use proper tools, and replace or repair defective tools.
- (8) Support the machine and attachment with supports or blocks if the work is performed in the lifted condition.

1.1.3 DISASSEMBLING AND ASSEMBLING HYDRAULIC EQUIPMENT



(1) Removing hydraulic equipment

1. Before disconnecting pipes, release the hydraulic pressure of the system, or open the return side cover and take out the filter.
2. Carefully drain oil of the removed pipes into a containers without spilling on the floor.
3. Apply plugs or caps on the pipe ends to avoid oil spillage and dust intrusion.
4. Clean off the external surface of the equipment before disassembling, and drain hydraulic and gear oil before placing it on the workbench.

(2) Disassembling hydraulic equipment

1. Do not disassemble, reassemble or modify the hydraulic equipment without the permission of the manufacturer, who is not responsible for the performance and function of the product after modification.
2. When disassembling and reassembling for unavoidable reason, refer the work to qualified personnel who have the specific knowledge or completed the parts service training.
3. Provide matching marks to facilitate reassembling work.
4. Before starting the work, read the manual of disassembling procedure, if it is provided, and decide whether the work can be performed by yourself.
5. Use the special jig and tools without fail if they are specified.
6. If it is hard to remove a part according to the procedure, do not try it by force but investigate the cause.
7. Place the removed parts in order and attach tags to facilitate the reassembling.
8. Note the location and quantity of parts commonly applied to multiple locations.

(3) Inspecting parts

1. Ensure that the disassembled parts are free from seizure, interference and uneven contact.
2. Measure and record wear condition of parts and clearance.
3. If the problem is found in a part, repair or replace it with a new one.

(4) Reassembling hydraulic equipment

1. Turn ON the ventilation fan or open windows to maintain good ventilation prior to starting the cleaning of parts.
2. Perform rough and finish cleaning before assembling.
3. Remove washing oil by air and apply clean hydraulic or gear oil for assembling.
4. Always replace the removed O-rings, backup rings and oil seals with new ones by applying grease in advance.
5. Remove dirt and moisture from and perform degreasing on the surface where liquid gasket to be applied.
6. Remove rust preventive agent from the new parts before use.
7. Fit bearings, bushings and oil seals using special jigs.
8. Assemble the parts utilizing matching marks.
9. Ensure all the parts are completely assembled after the work.

2.2 MACHINE DIMENSIONS

(1) E27B (CANOPY)

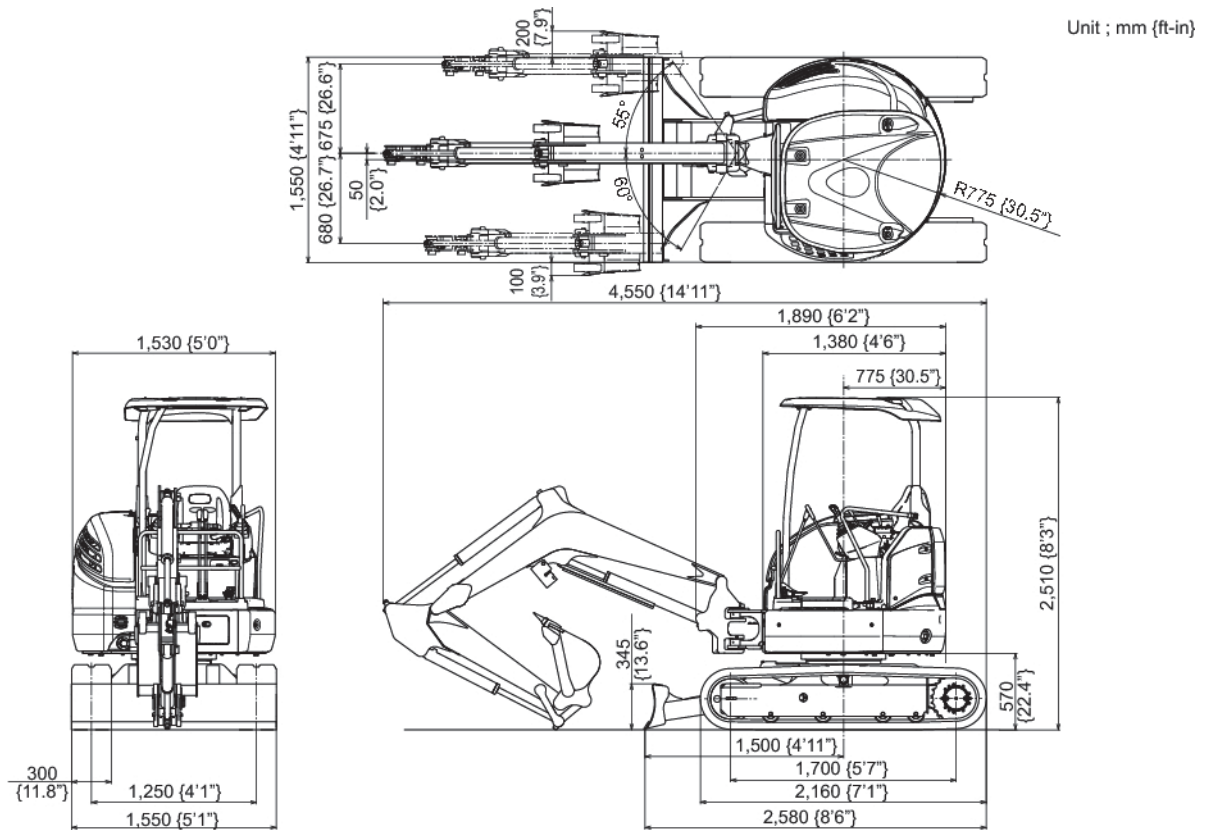

(2) E27B (CAB)

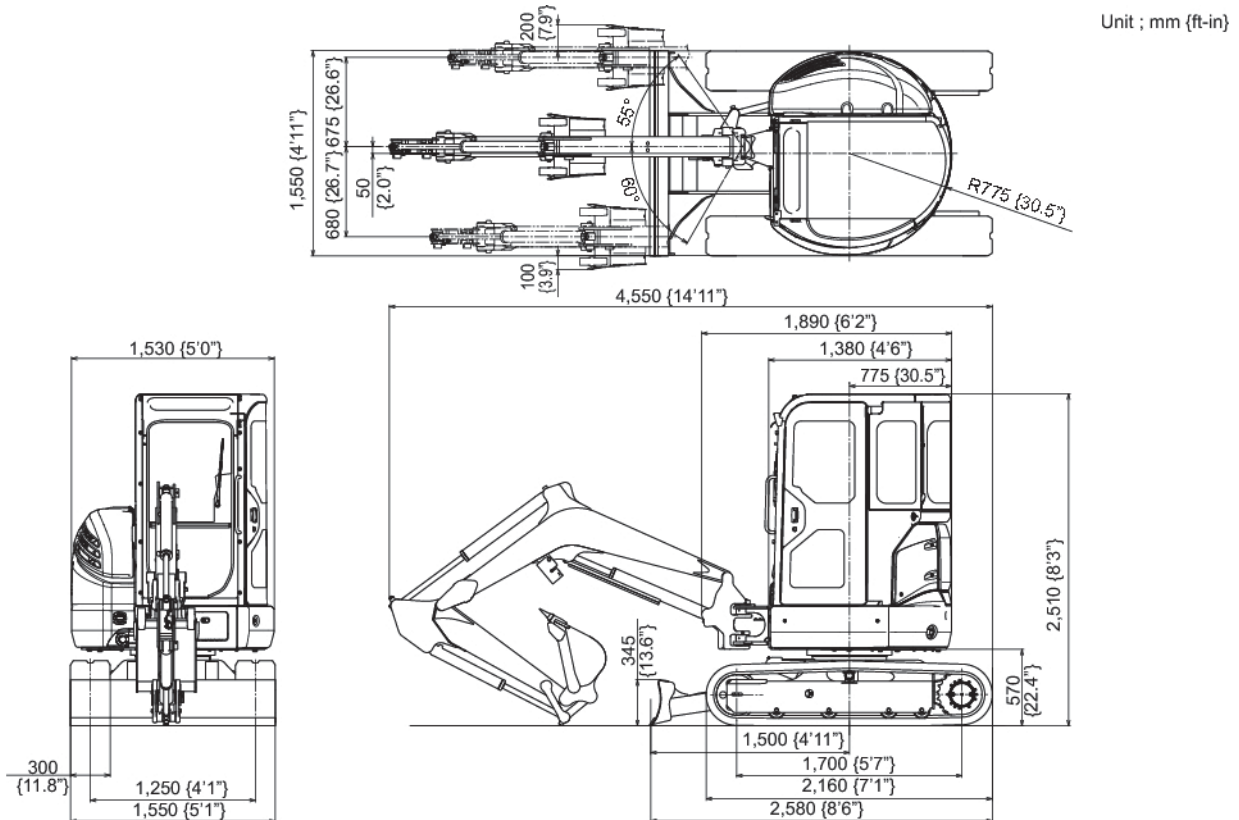

2.8.2 ENGINE PERFORMANCE CURVE

E27B

Model : 3TNV82A-B

Rated Output : 17.1 kW / 2400 min⁻¹ (24.8 PS / 2,400 rpm)

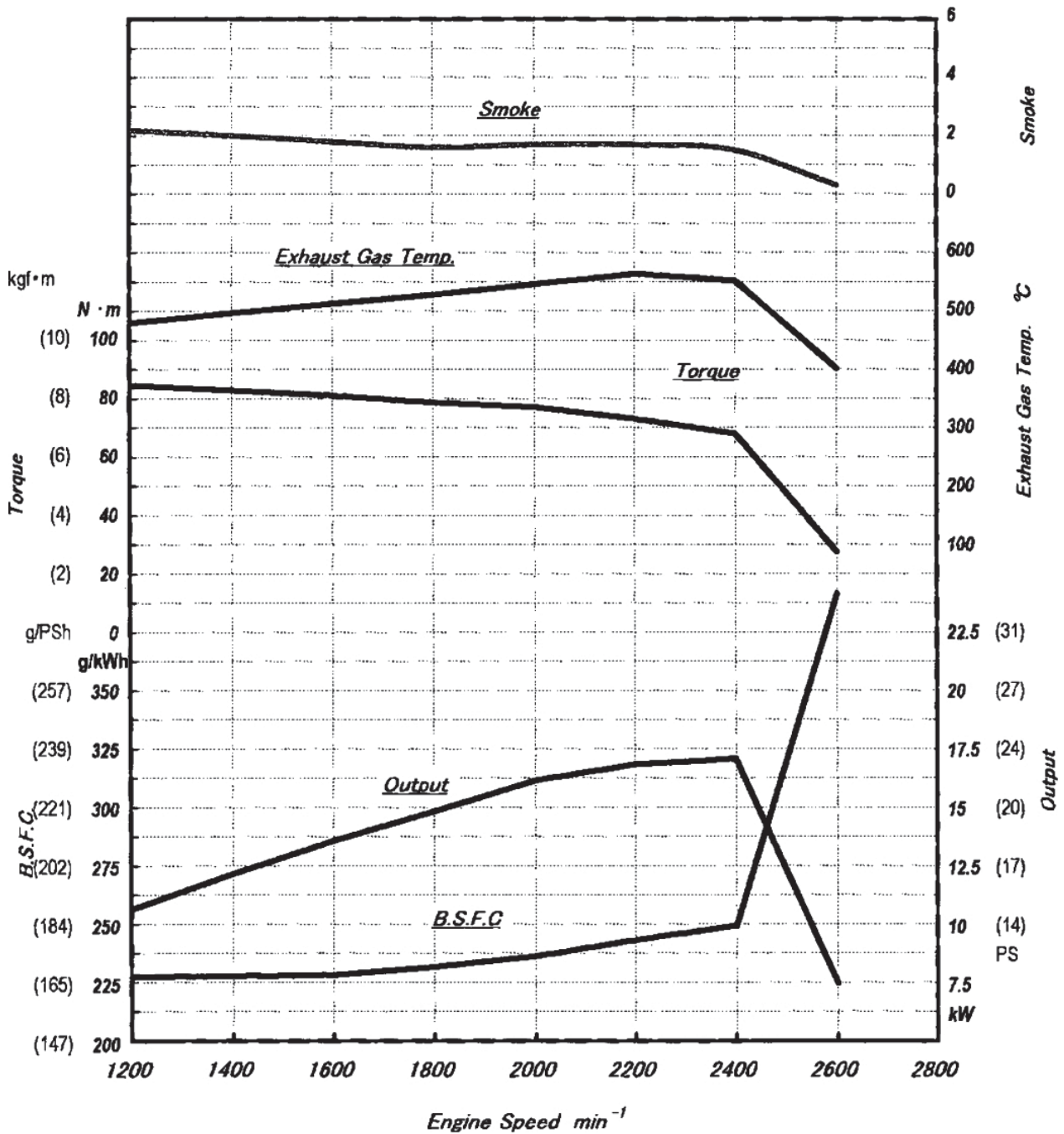

$$\begin{aligned} \text{Fuel consumption volume} &= \frac{F}{\rho \times 1000} \times P \times \alpha \\ &= \frac{260}{0.835 \times 1000} \times 17.1 \times \alpha \\ &= 5.32 \alpha \end{aligned}$$

F : Fuel consumption rate (g / kWh)
 P : Shaft output (kW)
 ρ : Specific gravity
 α : Standard load factor (0.60 ~ 0.70)
 Fuel consumption in normal operation ;
 3.19 ~ 3.72 L / h (load factor : (0.60 ~ 0.70))

[3. ATTACHMENT DIMENSIONS]

3.2.2 ARM MAINTENANCE STANDARDS

(1) Clearance of pin and bushing

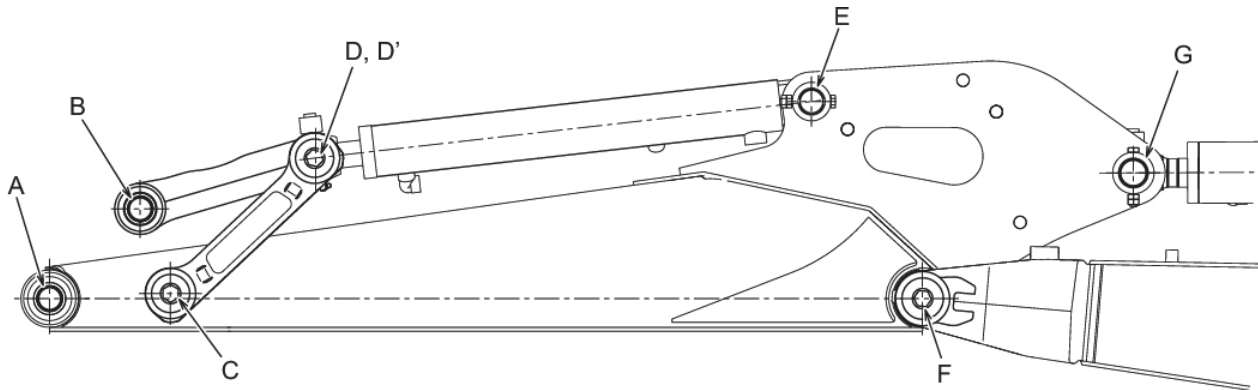

Clearance of pin and bushing on arm section

Unit : mm (in)

Pos.	Item	Pin part No.	Standard dimensions			Clearance			Remedy
			Pin dia.	Tolerance on pin dia.	Tolerance on bushing bore dia.	Standard value	Standard value for repair	Serviceability limit	
A	Arm point (Connected part of bucket)	PW12B01351P1	ø40 (1.575)	-0.02 -0.05 (-0.0008) (-0.0020)	+0.100 +0.075 (+0.0039) (+0.0030)	0.095- 0.15 (0.0037- 0.0059)	0.7 (0.028)	1.0 (0.039)	Replace bushing or pin
B	Bucket link (Bucket side)				+0.125 +0.100 (+0.0049) (+0.0039)	0.12- 0.175 (0.0047- 0.0069)			
C	Idler link (Connected part of arm)	+0.095 +0.070 (+0.0037) (+0.0028)			0.09- 0.145 (0.0035- 0.0057)				
D	Bucket link (Idler link side)	+0.095 +0.070 (+0.0070) (+0.0028)			0.09-0.145 (0.0035- 0.0057)				
D'	Bucket cylinder (Rod side)	+0.200 +0.050 (+0.0079) (+0.0020)			0.07- 0.25 (0.0028- 0.0098)				
E	Bucket cylinder (Head side)	+0.200 +0.050 (+0.0079) (+0.0020)			0.07- 0.25 (0.0028- 0.0098)				
F	Arm foot (Connected part of boom)	+0.121 +0.105 (+0.0048) (+0.0041)			0.125- 0.171 (0.0049- 0.0067)				
G	Arm cylinder (Rod side)	+0.250 +0.050 (+0.0098) (+0.0020)			0.07- 0.25 (0.0028- 0.0098)				

Note

- The tolerance for bushing inside diameter means the dimension after fitting of it into place.
- The part number for pins may be changed owing to improvement, use them only for reference.

3.5 SWING

3.5.1 SWING BRACKET DIMENSIONAL DRAWINGS

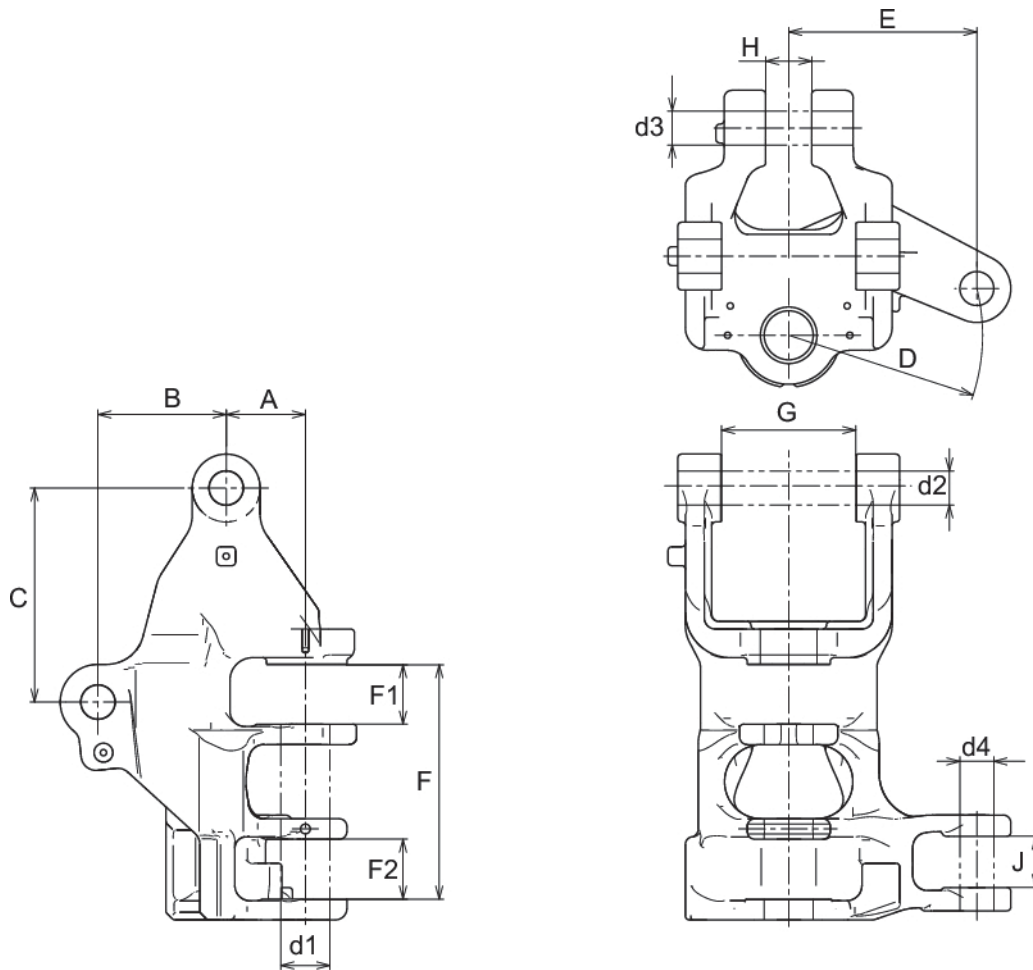

Swing bracket dimensional drawings

No.	NAME	DIMENSION [mm(in)]
A	Distance between swing center pin and boom foot pin	115 (4.53)
B	Distance between boom foot pin and boom cylinder pin	150 (5.91)
C	- ditto -	280 (11.0)
D	Distance between swing center pin and swing cylinder pin	R257 (10.12)
E	- ditto -	249.4 (9.82)
F	Inside width of swing center	311 (12.24)
F1	- ditto -	79 (3.11)
F2	- ditto -	79.5 (3.13)
G	Inside width of boom foot	178 (7.01)
H	Inside width for installing boom cylinder	61 (2.40)
J	Inside width for installing swing cylinder	58 (2.28)
d1	Pin dia. of swing center	60 dia.(2.36)
d2	Pin dia. of boom foot	40 dia.(1.57)
d3	Pin dia. of boom cylinder	45 dia.(1.77)
d4	Pin dia. of swing cylinder	35 dia.(1.38)

11.3 TORQUE SPECIFICATIONS FOR JOINTS AND HOSES

11.3.1 JOINTS FOR PIPING (O-RING SEALING TYPE)

Nominal screw size (PF)	Spanner size (mm)	Tightening torque N•m (lbf•ft)
1 / 8	14	17±2 (12±1)
1 / 4	19	36±2 (27±1)
3 / 8	22	74±5 (54±4)
1 / 2	27	108±9.8 (80±7)
3 / 4	36	162±9.8 (119±7)
1	41	255±9.8 (188±7)

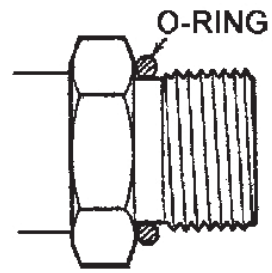

11.3.2 HYDRAULIC HOSE (30 DEG. FLARE TYPE)

Nominal screw size (PF)	Spanner size (mm)	Tightening torque N•m (lbf•ft)
1 / 8	17	15±2.0 (11±1)
1 / 4	19	29±4.9 (22±4)
3 / 8	22	49±4.9 (36±4)
1 / 2	27	78±4.9 (58±4)
3 / 4	36	118±9.8 (87±7)
1	41	137±15 (101±11)

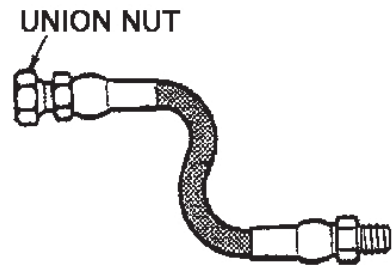

NOTE : The application of the tightening torque is subject to a dry condition.

[12. STANDARD MAINTENANCE TIME TABLE]

03 Upper structure (2/4)

No.	EQUIPMENT PORTION	WORK TO BE DONE	UNIT	REMARKS	UNIT : HOUR
50	Hydraulic oil tank portion			Refer to 33.1.11	
51	Hydraulic oil tank ASSY	Rem./Inst.	1 pc.		1.6
52	-Return filter	Replace	1 pc.	Include pressure releasing & replacing O-ring	0.2
53	-Hydraulic oil	Rem./Inst.	1 pc.		0.2
54	-Suction hose	Rem./Inst.	1 pc.		0.2
55	-Strainer	Replace	1 pc.	Include replacing O-ring	0.1
56	-Pilot return hose	Rem./Inst.	1 pc.		0.1
57	-Swivel drain hose	Rem./Inst.	1 pc.		0.1
58	-SOL. valve return hose	Rem./Inst.	1 pc.		0.1
59	-Swing, C / V return hose	Rem./Inst.	2 pcs.		0.2
60	-Tank fixing bolt	Rem./Inst.	4 pcs.		0.2
	Other necessary works	Rem./Inst.	1 pc.	Covers	0.2
		Rem./Inst.	1 pc.	Control valve	1.6
		Rem./Inst.	1 pc.	Solenoid valve	0.1
70	Pump portion			Refer to 33.1.7	
71	Pump ASSY	Rem./Inst.	1 pc.	After removing counterweight	1.3
72	-Hydraulic oil	Replace	1 pc.	Include pressure releasing	0.2
73	-Pilot delivery oil hose	Rem./Inst.	1 pc.		0.1
74	-Suction hose	Rem./Inst.	1 pc.		0.2
75	-Suction tube (pump side)	Rem./Inst.	1 pc.		0.2
76	-Main pump delivery hose	Rem./Inst.	3 pcs.		0.3
77	-Pump fixing bolt	Rem./Inst.	2 pcs.		0.2
78	Pump ASSY	O / H	1 pc.		3.0
	Other necessary works	Feed	1 pc.	Hyd. oil in pump	0.1
80	Radiator portion			Refer to 33.1.17	
81	Radiator ASSY	Rem./Inst.	1 pc.		1.3
82	-Coolant (LLC)	Replace	1 pc.		0.2
83	--Coolant density	Measuring	1 pc.		0.2
84	-Reserve tank hose	Rem./Inst.	1 pc.		0.1
85	-Radiator hose	Rem./Inst.	2 pcs.		0.2
86	-Cooler hose	Rem./Inst.	2 pcs.		0.2
87	-Radiator fixing bolt	Rem./Inst.	3 pcs.		0.1
88	-Radiator lifting or slinging	Rem./Inst.	1 pc.		0.1
	Other necessary works	Rem./Inst.	1 pc.	Counterweight	0.4
		Rem./Inst.	1 set	Covers	0.2
		Rem./Inst.	1 pc.	Duct	0.1

(4) Other Precautions

1. Parts with Aging Effect :

The rubber products such as hydraulic hoses, O-rings, oil seals, etc. are deteriorated with the aging effect. It is necessary to replace them to new ones at periodical intervals or at every overhaul.

2. Parts required Periodical Replacement :

It is recommendable to designate the important hoses critical to secure the safety as Very Important Parts (V.I.P.), and periodically replace with new ones.

3. Inspection & Replacement of Lubricants :

It is necessary for the user of the machine to fully familiarize himself with the procedures and precautions to handle the machine in safe and carry out the maintenance, as well as the procedures for inspection and lubrication. Refer to the OPERATION & MAINTENANCE MANUAL as well.

13.5.3 MOVEMENT DRIFT DUE TO GRAVITY

Measure the movement distance of machine on a slope due to machine's own weight, holding the machine for 5 minutes on the slope.

Measuring Conditions :

- Engine : Stopped
- Hydraulic Oil Temp. : 50 to 60C degrees (122 to 140F degrees)
- Gradient : 15° (Approx. 1/3.73)
- Machine posture : Fully extending the boom, arm and bucket cylinders, and fully retracting the dozer cylinder.

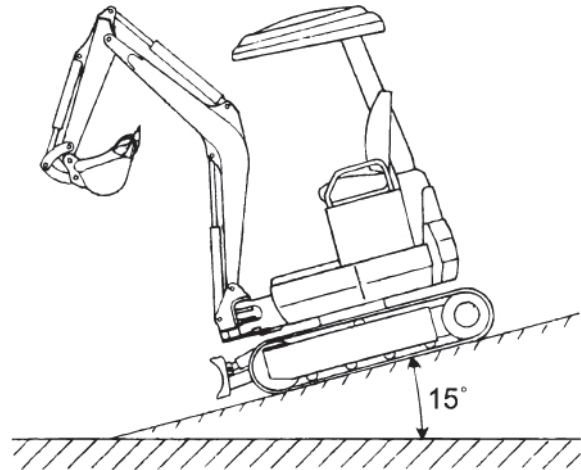

13.5.4 DRAIN RATE OF TRAVEL MOTOR

(1) Preparation

1. Apply stopper pins for both travel sprockets of left and right.
2. Stop the engine, and release air in the hydraulic oil tank.
3. Connect a hose to the drain port of travel motor, and receive the drained oil in a container.
4. Apply a plug to the drain piping at tank side.

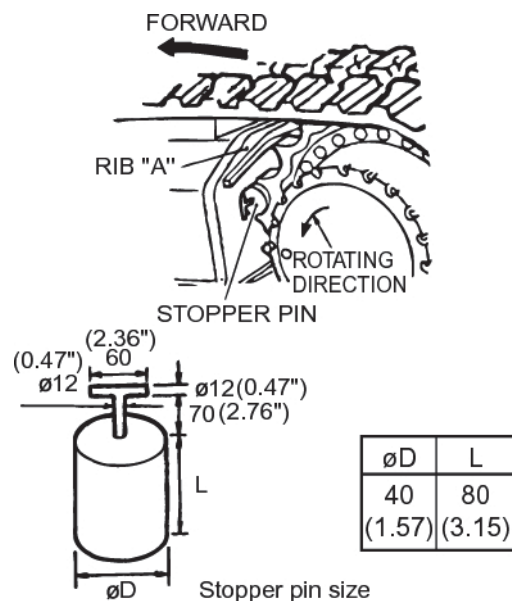

Make sure of the rotating direction of travel motor referring to the figure. Otherwise, the rib "A" may be broken by the stopper pin.

[21. MECHATRO CONTROLLER (OPT.)]

(2) Service Diagnosis Display Screen (Example)

The following table lists the service diagnosis display screens. (These examples are for when the engine is stopped.)

No.	Displays	Contents	No.	Displays	Contents
1	No.1 MAIN CONT. P/N PS22E00001F1 VER 1.00 CLUSTER GAUGE P/N PS59S00001F1 VER 0.18	Main controller P/No. indication Program version indication Cluster gauge P/No. indication Program version indication	6	No.6 DIGITAL INPUT D11 OFF D15 OFF D16 ON D17 OFF D18 ON D19 OFF	ON / OFF indication ON / OFF indication ON / OFF indication ON / OFF indication ON / OFF indication ON / OFF indication
2	No.2 ENG SPEED SET 1150rpm MEAS 0rpm ACCEL POS. 0% ENG POS. DEAD CHARGE DEAD WATER TEMP 159F OFF FUEL LEVEL 0.9V 100% FUEL RATE 0.0L/h HOURMETER 59Hr	No load setting rpm(Engine controller) Actual rpm Accel voltage % indication(Engine controller) Enigne oil switch Charge Water temperature sensor Water level switch Fuel level Fuel consumption level(Engine controller) Hour meter	7	No.7 DIGITAL INPUT D113 OFF D114 OFF D115 OFF D116 OFF D117 OFF D118 OFF	ON / OFF indication ON / OFF indication ON / OFF indication ON / OFF indication ON / OFF indication ON / OFF indication
3	No.3 RELAY SEQUENCE RELAY OFF BOOM LOWER RELAY OFF	Set value Set value	8	No.8 DIGITAL OUTPUT D01 COMP. OFF MEAS. OFF D02 COMP. OFF MEAS. ON D03 COMP. OFF MEAS. OFF D04 COMP. OFF MEAS. ON	Set value in computer Measured value Set value in computer Measured value Set value in computer Measured value Set value in computer Measured value
4	No.4 PRESSURE/POTENTIO SENSOR BOOM-HEAD 3.7V 6119.0PSI BOOM-ROD 2.9V 4640.0PSI BOOM 2.9V 105° ARM 2.9V 127° OFFSET 0.0V 0°	Sensor voltage / Pressure converted value Sensor voltage / Pressure converted value Sensor voltage / Pressure converted value Sensor voltage / Pressure converted value Sensor voltage / Pressure converted value	9	No.9 ENG CONT. TRANS. COUNT. 0 RECEIVER COUNT. 0 BAROMETRIC P. 101.0kPa FUEL TEMP. 82F INT.PRESSURE.COMP. 102kPa MEAS. 100.8kPa DPF REGENE STATE --- DPF REGENE ADVANCE 0% Ash PILE 0.10g/L PM PILE 1.80g/L	Counted number of transmission error Counted number of reception error Atmospheric pressure Fuel temperature Intake pressure/Set value /Measured value DPF regeneration Advancing DPF regeneration Ash pile PM pile
5	No.5 PROPO-VALUE BOOM RAISE COMP. 200mA 435.0PSI MEAS. 0mA 435.0PSI ARM IN COMP. 200mA 435.0PSI MEAS. 0mA 435.0PSI OFFSET LEFT COMP. 200mA 435.0PSI MEAS. 0mA 435.0PSI	Set value / Pressure converted value Measured value/Pressure converted value Set value / Pressure converted value Measured value/Pressure converted value Set value / Pressure converted value Measured value/Pressure converted value	10	No.10 ENG CONT. CHANGE TIME 71hr INJECT. QUANT. COMP. 0.0mm3/st MEAS. 0.0mm3/st ENG RAIL PRESS 145PSI EGR VALVE DIVER. COMP. 16STEP MEAS. 16STEP	Total operating time Injection quantity/Set value /Measured value Engine rail pressure EGR valve/Set value /Measured value



The values related to the engine controller are not displayed on the multi-display of the Tier 3 specification machines.

[21. MECHATRO CONTROLLER (OPT.)]

a. 70 pin connector (CN501,CN502)(3/3)

PinNo.	Input/ output	Name	Signal level	Functionality
58	I	D-IN13	Digital input 13 (EARTH/OPEN)	Charge
59	I	D-IN14	Digital input 14 (EARTH/OPEN)	High reach (stationery)
60	I	D-IN15	Digital input 15 (EARTH/OPEN)	High reach (travel)
61	I	D-IN16	Digital input 16 (EARTH/OPEN)	Interference prevention release
62	I	D-IN17	Digital input 17 (EARTH/OPEN)	Interference prevention release switch
63	I	D-IN18	Digital input 18 (EARTH/OPEN)	Interference prevention release switch
64	I	D-IN19	Digital input 19 (EARTH/OPEN)	
65	O	ADVCC9	5V power source for sensor 9	
66	I	AIN9	Analog input 9	
67		AIN9_GND	Analog GND	
68	O	ADVCC10	5V power source for sensor 10	
69	I	AIN10	Analog input 10	
70		AIN10_GND	Analog GND	

22.2.2 NIBBLER & BREAKER SPECIFICATIONS

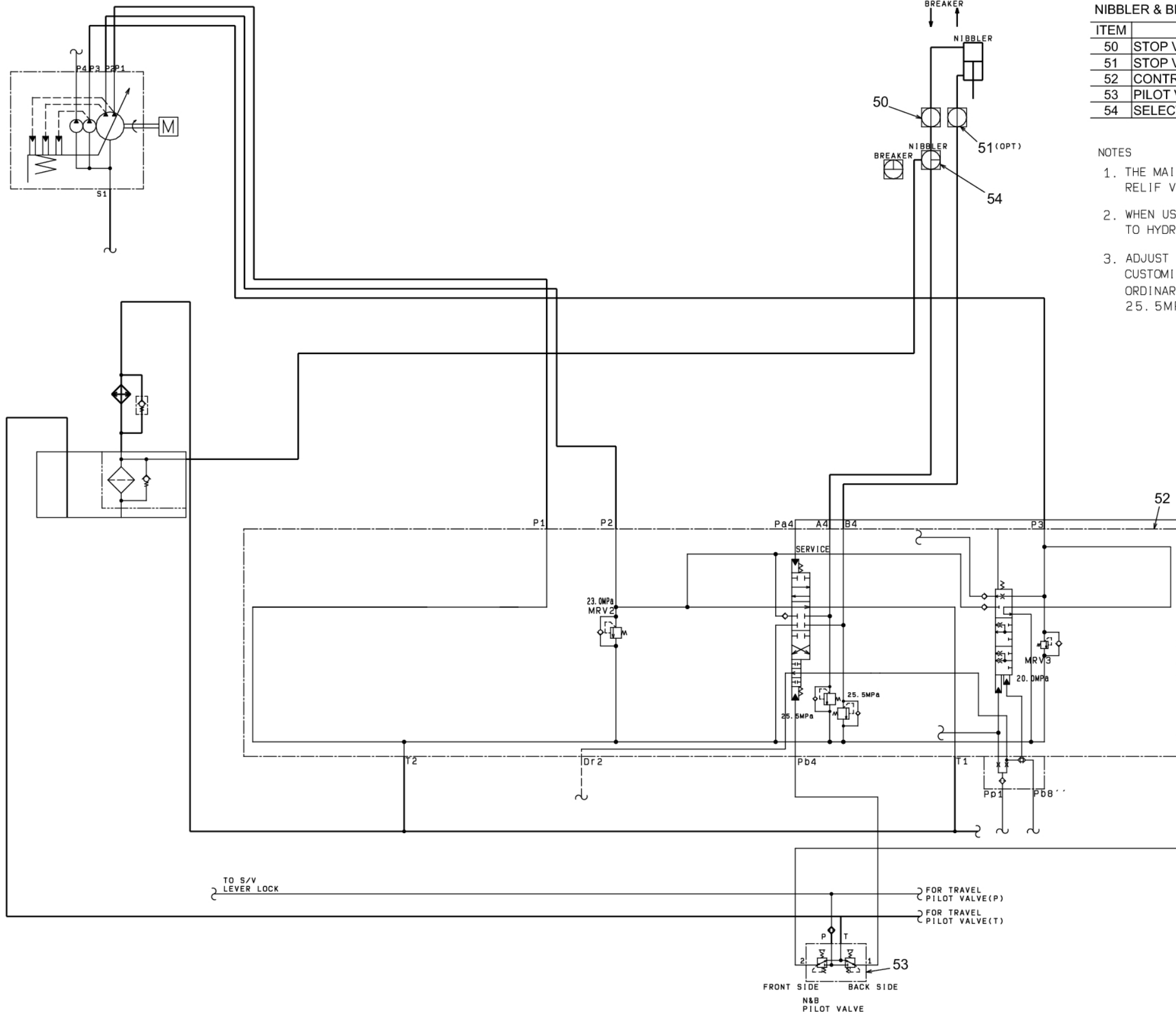

NIBBLER & BREAKER SPECIFICATIONS		PD01Z00002P1	
ITEM	NAME	P/No.	TYPE
50	STOP VALVE ASSY	YN25V00011F1	ST620-0210
51	STOP VALVE ASSY	YN25V00012F1	ST620-0200
52	CONTROL VALVE ASSY	PD30V00002F1	BCV35
53	PILOT VALVE	PB30V00002F2	PV6P1075
54	SELECTOR VALVE	PA30V00005F1	

- NOTES
1. THE MAIN CONTROL VALVE OF THE ITEM51 ADDS TWO OVERLOAD RELIF VALVE TO PD01Z00001P1 (STD) IN A SERVICE PORT.
 2. WHEN USING BREAKER, SET B SELECT VALVE (ITEM 54) TO RETURN TO HYDRAULIC TANK DIRECTLY HYDRAULIC OIL FROM BREAKER.
 3. ADJUST OVERLOAD RELIEF VALVE OF SERVICE PORT TO CUSTOMIZE SPECIFICATION.
ORDINARY SET PRESSURE
25.5 MPa

22.3.4 SWING OPERATION CIRCUIT

Pilot hydraulic system operated by the control lever

communicating with the tank.

22.3.4.1 SWING (LEFT) OPERATION CIRCUIT

(1) Pilot Circuit

1. Switching swing spool

When the swing (left) operation is performed, the pilot secondary pressure is output from pilot valve (11). The pressure oil flows to the Pb2 port of control valve (2) and switches the swing spool.

2. Releasing parking brake

The pilot primary pressure is always conducted to the PB port of hydraulic timer (303). When the swing operation is performed, the pilot secondary pressure is conducted to the PP port of hydraulic timer (303) through shuttle valve (15) to switch the spool. The pilot primary pressure of 3.5 MPa enters parking brake (302) to release it. (The arm in operation also releases the swing brake.)

3. Actuating parking brake

When the control lever is returned to neutral to stop the swing, the pilot secondary pressure is shut off, timer valve (303) is switched, and the pressure oil is blocked. The oil in the brake cylinder is pushed out by spring force and discharged through the throttle of timer valve (303). This actuates the brake after 3.0 to 6.0 seconds, absorbing the inertial force at swing stop smoothly.

(2) Main Circuit

1. Supply circuit to swing motor (3)

The oil delivered from the P3 port of hydraulic pump (1) enters the P3 port of control valve (2), and goes through the swing valve. Then it is supplied from the B2 port to the A port of swing motor (3) to rotate the swing motor.

2. Swing motor (3)

- a. Relief valve (304) relieves rapid pressure rise to absorb the shock of starting or stopping the motor.
- b. To avoid negative pressure being generated in the swing motor by the inertia of the upper structure when the swing is stopped, make-up valve (check valve) (305) prevents cavitation by supplying oil to the swing motor from the return circuit [T1 and T2 ports of control valve (2)]

22.3.9 DOZER OPERATION CIRCUIT

Pilot hydraulic system operated by the control lever

22.3.9.1 DOZER DOWN OPERATION CIRCUIT

(1) Dozer Operation

When the control lever is pushed forward, the pilot secondary pressure is output from pilot valve (14) and goes through the Pb1 port of control valve (2) to switch the dozer spool.

(2) Main Circuit

1. Supply circuit to cylinder (9)

The oil delivered from the P3 port of hydraulic pump (1) enters the P3 port of control valve (2) and flows to the B1 port via the dozer valve.

Then, the pressure oil goes through swivel joint (10) is supplied to the H side of dozer cylinder (9) to actuate the dozer down operation.

23.3.3 OPERATORS CONTROL

23.3.4 CONTROL LEVER ASSY

OPERATORS CONTROLS

OPERATORS CONTROLS		PX03M00030F1	(04)	
ITEM	PART NAME	PARTS No.	QTY	REMARKS
10	SWITCH	PY50S00004P2	1	WIPER/WASHER (FOR CAB)

CONTROL LEVER ASSY

CONTROL LEVER ASSY		PX50M00004F1	(01)	
ITEM	PART NAME	PARTS No.	QTY	REMARKS
4	GRIP ASSY	YN03M01286F1	1	1-2 SPEED CHANGE

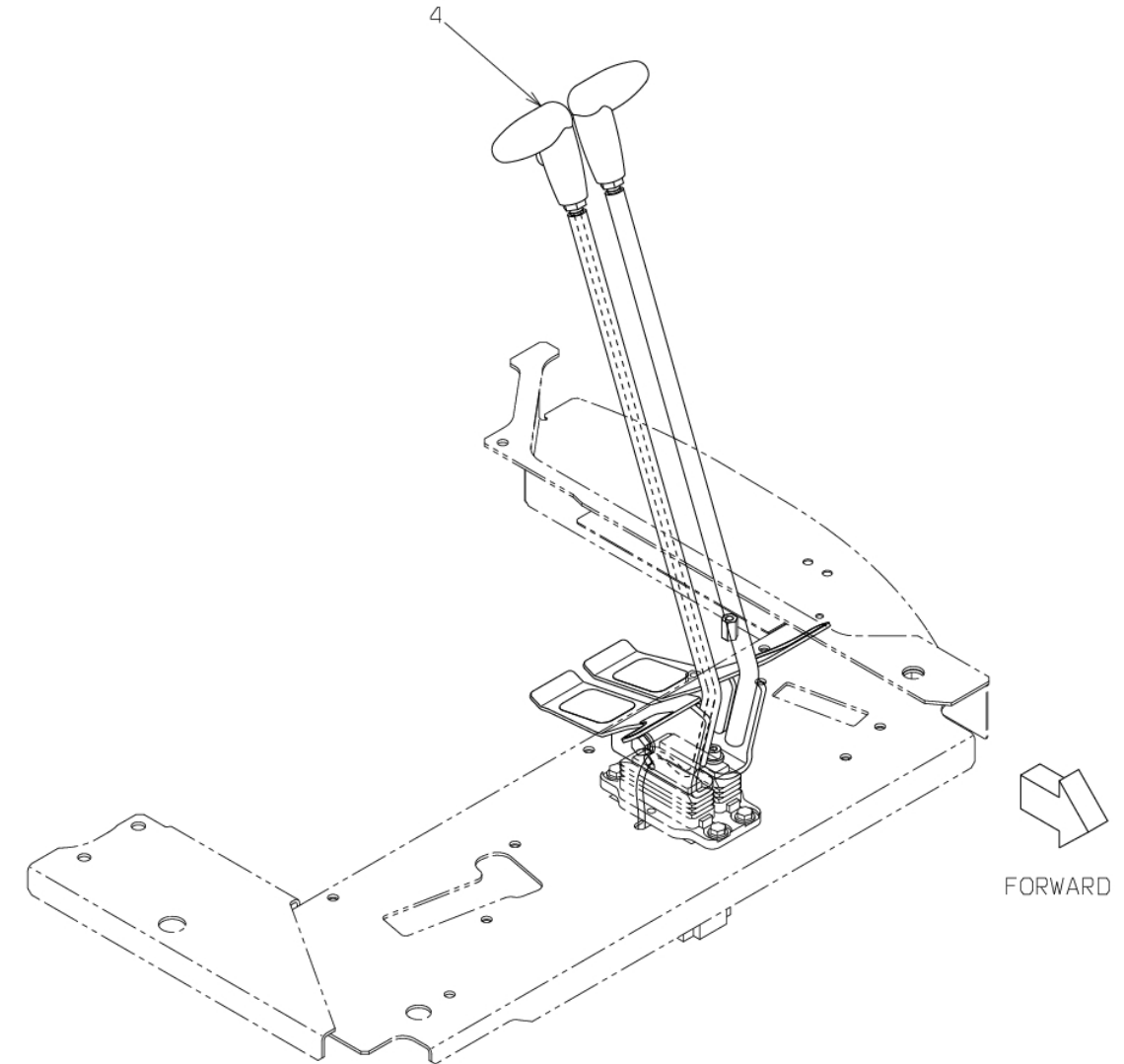
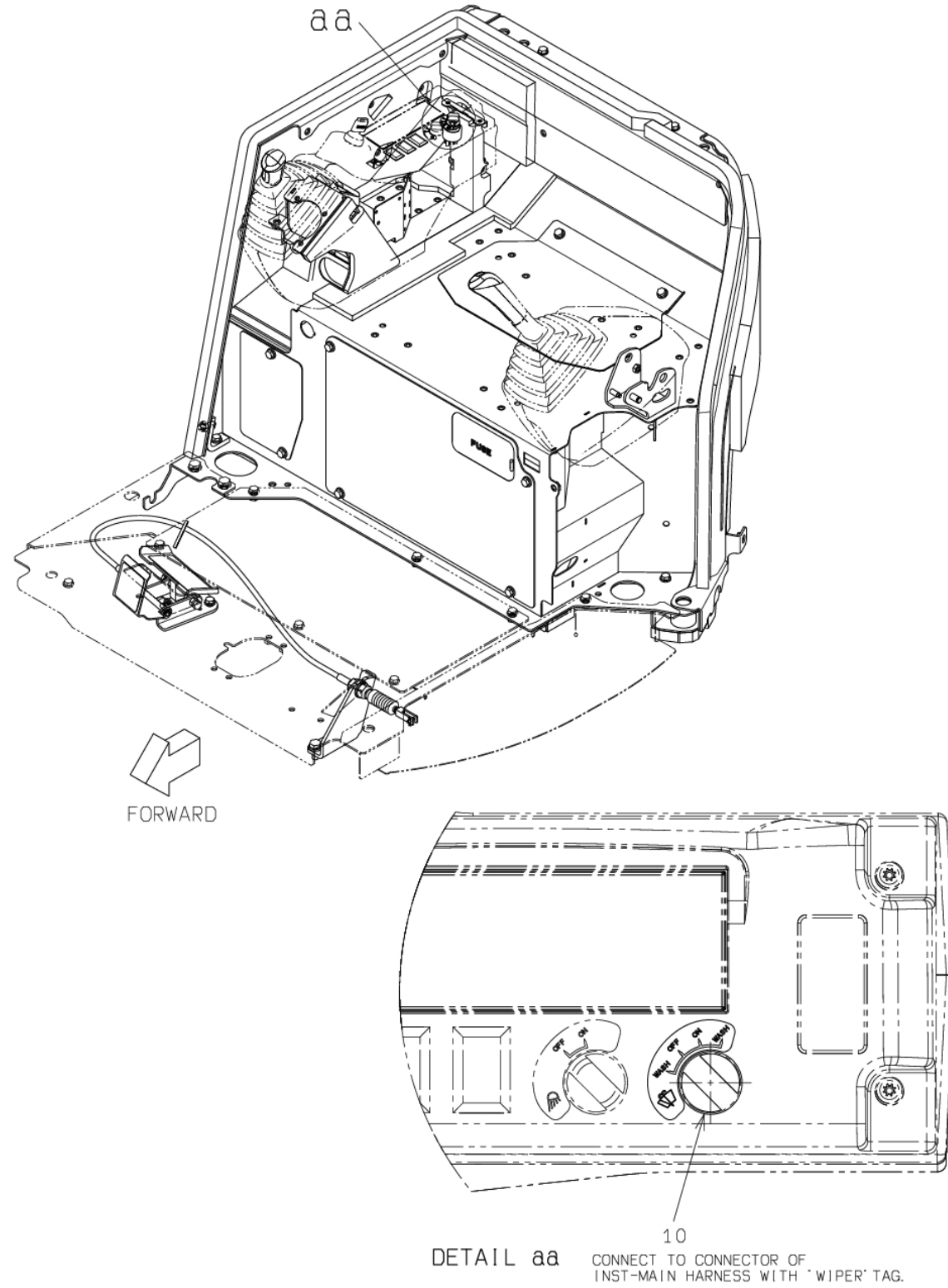

23.3.10.8 HARNESS : PX13E01020P2

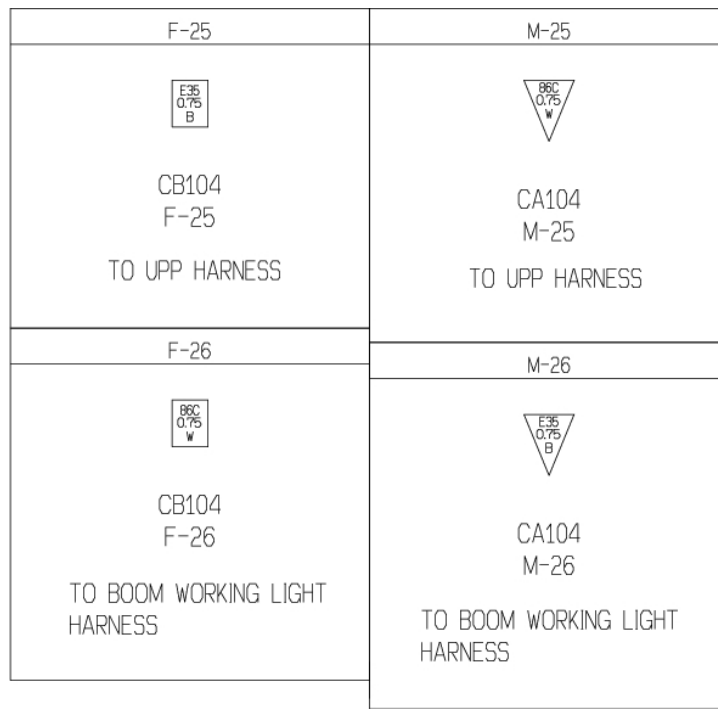

CONNECTORS SELECTION TABLE

CONNECTER NAME (PIN NUM)	MANUFUC.	PART NUMBER	
		HOUSING	TERMINAL
CA104	AMP/YAZAKI	170887-1 (AMP)	170002-5
		7120-8012 (YAZAKI)	
CB104	AMP/YAZAKI	170889-1 (AMP)	170003-5
		7120-1010 (YAZAKI)	

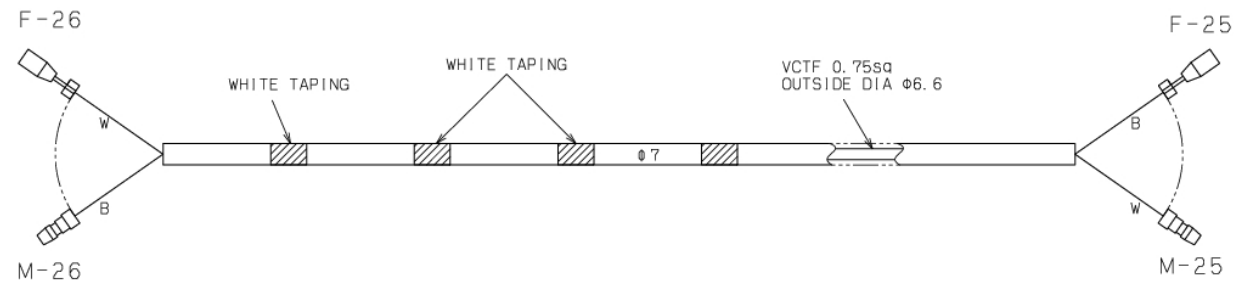

WIRE NO	WIRE COLOR	WIRE SIZE (mm ²)	FROM	CONNECTION	TO
B6C	W	VCTF0.75(2C)	F-26	—————	M-25
E35	B	VCTF0.75(2C)	M-26	—————	F-25

23.3.11.1 FLOOR HARNESS (6/6) : PX13E01079P2

WIRE NO	WIRE COLOR	WIRE SIZE (mm ²)	FROM	CONNECTION	TO
1A	Br	AVSS0.5f	CN-20F	┌───┐	CN-14F
1B	Br	AVSS0.5f	CN-27F	┌───┐	CN-14F
1C	Br	AVSS0.5f	CN-27F	┌───┐	CN-14F
1D	Br	AVSS0.5f	CN-27F	┌───┐	CN-14F
1E	Br	AVSS0.5f	T-2	┌───┐	CN-14F
1F	Br	AVSS0.5f	CN-246F	┌───┐	CN-14F
1G	Br	AVSS0.5f	CN-1F	┌───┐	CN-14F
1H	Br	AVSS0.5f	CN-193F	┌───┐	CN-14F
1J	Br	AVSS0.5f	CN-221F	┌───┐	CN-14F
1K	Br	AVSS0.5f	CN-147F	┌───┐	CN-14F
2A	G/B	AVSS1.25	CN-20F	┌───┐	CN-14F
2B	G/B	AVSS1.25	CN-3F	┌───┐	CN-14F
2C	G/B	AVSS1.25	CN-2F	┌───┐	CN-14F
3	L	AVSS1.25	CN-20F	┌───┐	CN-129F
4A	R/G	AVSS1.25	CN-20F	┌───┐	CN-129F
5A	W	AVSS2	CN-20F	┌───┐	CN-129F
6A	W/G	AVSS0.5f	CN-24F	┌───┐	CN-20F
7A	G/R	AVSS0.75f	CN-20F	┌───┐	CN-217F
7B	G/R	AVSS0.75f	CN-142F	┌───┐	CN-217F
7C	G/R	AVSS0.75f	CN-108F	┌───┐	CN-217F
8B	G	AEX1.25	CN-60F	┌───┐	CN-221F
8E	G	AVSS1.25	CN-20F	┌───┐	CN-221F
9A	L	AVSS0.75f	CN-20F	┌───┐	CN-15F
9B	L	AVSS0.75f	CN-39F	┌───┐	CN-15F
9C	L	AVSS0.5f	CN-38F	┌───┐	CN-15F
9D	L	AVSS0.75f	CN-113F	┌───┐	CN-15F
9E	L	AVSS0.5f	CN-6F	┌───┐	CN-15F
10A	R	AVSS0.75f	CN-20F	┌───┐	CN-17F
10B	R	AVSS0.75f	CN-358F	┌───┐	CN-17F
10C	R	AVSS0.5f	CN-224F	┌───┐	CN-17F
10D	R	AEX0.75f	CN-61F	┌───┐	CN-17F
10E	R	AEX0.75f	CN-61F	┌───┐	CN-17F
10G	R	AVSS0.5f	CN-10F	┌───┐	CN-17F
10H	R	AVSS0.5f	CN-29F	┌───┐	CN-17F
10J	R	AVSS0.5f	CN-44F	┌───┐	CN-17F
10K	R	AVSS0.5f	CN-147F	┌───┐	CN-17F
11A	G/L	AVSS1.25	CN-20F	┌───┐	CN-34F
12	W/B	AVSS1.25	CN-20F	┌───┐	CN-37F
13A	Lg	AVSS0.5f	CN-20F	┌───┐	CN-17F
13B	Lg	AVSS0.5f	CN-2F	┌───┐	CN-17F
13C	Lg	AVSS0.5f	CN-2F	┌───┐	CN-17F
13D	Lg	AVSS0.5f	CN-147F	┌───┐	CN-17F
13E	Lg	AVSS0.5f	CN-221F	┌───┐	CN-17F
14	B/Y	AVS3	CN-20F	┌───┐	CN-334F
15A	L	AVSS1.25	CN-20F	┌───┐	CN-19F
16A	L/R	AVSS1.25	CN-20F	┌───┐	CN-15F
16B	L/R	AVSS0.75f	CN-76F	┌───┐	CN-15F
16C	L/R	AVSS0.5f	CN-2F	┌───┐	CN-15F
17	R	AVSS1.25	CN-20F	┌───┐	CN-221F
18A	G	AVSS1.25	CN-20F	┌───┐	CN-221F
20	G	AVSS1.25	CN-3F	┌───┐	CN-2F
21	W	AVSS1.25	CN-3F	┌───┐	CN-2F
22	L	AVSS1.25	CN-3F	┌───┐	CN-2F
43A	Lg	AVSS0.75f	CN-109F	┌───┐	CN-217F
43B	Lg	AVSS0.75f	CN-1F	┌───┐	CN-217F
43C	Lg	AVSS0.5f	CN-39F	┌───┐	CN-217F
45	G	AVSS0.5f	CN-38F	┌───┐	CN-1F
46	W/B	AVSS0.5f	F-39	┌───┐	CN-1F
47A	L/W	AEX3	CN-25F	┌───┐	CN-60F

WIRE NO	WIRE COLOR	WIRE SIZE (mm ²)	FROM	CONNECTION	TO
48A	V	AVSS0.5f	CN-27F	┌───┐	CN-220F
48B	V	AVSS0.5f	CN-16F	┌───┐	CN-220F
48D	V	AVSS0.5f	CN-221F	┌───┐	CN-220F
49	P	AVSS0.5f	T-1	┌───┐	CN-16F
50A	W	AVSS0.5f	CN-27F	┌───┐	CN-220F
50B	W	AEX0.75f	CN-61F	┌───┐	CN-220F
50C	W	AVSS0.5f	CN-147F	┌───┐	CN-220F
50E	W	AVSS0.5f	CN-221F	┌───┐	CN-220F
50F	W	AVSS0.5f	CN-193F	┌───┐	CN-221F
51A	G	AVSS0.5f	CN-27F	┌───┐	CN-15F
51B	G	AEX0.5f	CN-61F	┌───┐	CN-15F
51C	G	AVSS0.5f	CN-147F	┌───┐	CN-15F
51D	G	AVSS0.5f	CN-221F	┌───┐	CN-15F
52A	R	AVSS0.5f	CN-27F	┌───┐	CN-220F
52B	R	AEX0.5f	CN-61F	┌───┐	CN-220F
52C	R	AVSS0.5f	CN-221F	┌───┐	CN-220F
55A	Y/G	AEX0.5f	CN-315F	┌───┐	CN-61F
56A	Y	AVSS0.5f	CN-27F	┌───┐	CN-220F
56B	Y	AEX0.5f	CN-61F	┌───┐	CN-220F
56C	Y	AVSS0.5f	CN-221F	┌───┐	CN-220F
57A	G	AVSS0.5f	CN-27F	┌───┐	CN-220F
57B	G	AVSS0.5f	CN-39F	┌───┐	CN-220F
57C	G	AVSS0.5f	CN-221F	┌───┐	CN-220F
58	L	AEX0.5f	CN-27F	┌───┐	CN-61F
60	G/Y	AVSS0.75f	CN-113F	┌───┐	CN-6F
61A	R	AVSS0.5f	CN-1F	┌───┐	CN-14F
61B	R	AVSS0.5f	CN-6F	┌───┐	CN-14F
61C	R	AVSS0.5f	CN-38F	┌───┐	CN-14F
61D	R	AVSS0.5f	CN-221F	┌───┐	CN-14F
63	Y/G	AVSS0.5f	CN-113F	┌───┐	CN-6F
64	P	AVSS0.5f	CN-113F	┌───┐	CN-6F
70A	B/R	AEX3	CN-335F	┌───┐	CN-60F
71A	W/L	AVS5	CN-10F	┌───┐	
71B	W/L	AVS2	CN-20F	┌───┐	
71C	W/L	AVSS1.25	CN-20F	┌───┐	
71D	W/L	AVSS1.25	CN-20F	┌───┐	
71E	W/L	AVSS1.25	CN-20F	┌───┐	
71F	W/L	AVSS1.25	CN-20F	┌───┐	
72	L	AVSS1.25	CN-20F	┌───┐	CN-26F
114	Gr/G	AVSS0.5f	CN-147F	┌───┐	CN-16F
81B	Br	AEX0.5f	CN-61F	┌───┐	CN-16F
86A	R	AVSS0.5f	CN-27F	┌───┐	CN-37F
86B	R	AVSS1.25	CN-15F	┌───┐	CN-37F
86C	R	AEX1.25	CN-15F	┌───┐	CN-61F
86E	R	AVSS1.25	CN-15F	┌───┐	CN-2F
86F	R	AVSS0.5f	CN-15F	┌───┐	CN-221F
90	R/W	AVSS1.25	CN-112F	┌───┐	CN-129F
93	L	AEX1.25	CN-61F	┌───┐	CN-129F
134B	R	AEX1.25	CN-61F	┌───┐	CN-34F
261	R/Y	AVSS0.75f	CN-109F	┌───┐	CN-39F
262A	R	AVSS1.25	CN-20F	┌───┐	CN-26F
262B	R	AVS5	CN-20F	┌───┐	
262C	R	AVS5	CN-10F	┌───┐	
262D	R	AVS5	CN-25F	┌───┐	
262E	R	AVS3	CN-45F	┌───┐	
262F	R	AEX8	CN-62M	┌───┐	
262G	R	AEX5	CN-62M	┌───┐	

WIRE NO	WIRE COLOR	WIRE SIZE (mm ²)	FROM	CONNECTION	TO
264A	G/B	AVSS1.25	CN-147F	┌───┐	CN-17F
264B	G/B	AVSS0.75f	CN-26F	┌───┐	CN-17F
264C	G/B	AVSS1.25	CN-19F	┌───┐	CN-17F
265	W	AEX0.75f	CN-44F	┌───┐	CN-61F
266	Lg/R	AVSS1.25	CN-44F	┌───┐	CN-142F
267	R/W	AEX3	CN-45F	┌───┐	CN-60F
268A	W/G	AVSS0.5f	CN-9F	┌───┐	CN-224F
268B	W/G	AVSS0.5f	CN-29F	┌───┐	CN-224F
269A	R/W	AVSS0.5f	CN-9F	┌───┐	CN-224F
269B	R/W	AVSS0.5f	CN-29F	┌───┐	CN-224F
270	G	AEX1.25	CN-61F	┌───┐	CN-129F
272	R/L	AVSS1.25	CN-147F	┌───┐	CN-142F
274	W/B	AVSS1.25	CN-147M	┌───┐	CN-147M
326A	R	AVSS0.5f	CN-16F	┌───┐	
326B	R	AVSS0.5f	CN-246F	┌───┐	
326C	R	AVSS0.5f	CN-246F	┌───┐	
345P	G	AVSS1.25	CN-358F	┌───┐	CN-221F
345Q	G	AVSS1.25	CN-246F	┌───┐	CN-221F
350A	P	AVSS0.5f	CN-24F	┌───┐	CN-315F
404A	Br/B	AVSS0.75f	CN-142F	┌───┐	CN-217F
404B	Br/B	AVSS0.75f	CN-108F	┌───┐	CN-217F
404C	Br/B	AVSS0.75f	F-8	┌───┐	CN-217F
412A	Y	AEX0.75f	CN-61F	┌───┐	CN-221F
415A	L	AEX0.75f	CN-61F	┌───┐	
415B	L	AVSS0.75f	CN-358F	┌───┐	
415C	L	AVSS0.75f	CN-358F	┌───┐	
E14	B	AVSS1.25	CN-107F	┌───┐	CN-2F
E26	B	AVSS0.5f	CN-107F	┌───┐	F-40
E31	B	AVSS1.25	CN-107F	┌───┐	CN-2F
E32	B	AVSS0.5f	CN-107F	┌───┐	CN-2F
E40	B	AVSS1.25	CN-107F	┌───┐	CN-112F
E107	B	AVSS0.75f	CN-107F	┌───┐	CN-224F
E47	B	AVSS1.25	CN-107F	┌───┐	P-22
E46	B	AVSS1.25	CN-33F	┌───┐	P-22
E18	B	AVSS0.75f	CN-33F	┌───┐	CN-113F
E22	B	AEX0.75f	CN-33F	┌───┐	CN-61F
E23	B	AEX0.5f	CN-33F	┌───┐	CN-61F
E42	B	AEX0.5f	CN-33F	┌───┐	CN-61F
E81	B	AVSS0.75f	CN-33F	┌───┐	CN-221F
E49	B	AVSS1.25	CN-33F	┌───┐	CN-33F
E48	B	AVSS1.25	CN-107F	┌───┐	CN-107F
E19	B	AVSS1.25	CN-107F	┌───┐	CN-33F
E17	B	AVSS0.75f	CN-19F	┌───┐	CN-33F
E25	B	AVSS0.75f	CN-76F	┌───┐	CN-33F
E35	B	AEX1.25	CN-61F	┌───┐	CN-33F
E92	B	AVSS0.75f	CN-147F	┌───┐	CN-33F
E2	B	AVSS0.5f	CN-38F	┌───┐	CN-33F
E1	B	AVSS0.5f	CN-38F	┌───┐	CN-27F
E8	B	AVSS0.75f	CN-1F	┌───┐	CN-16F
E7	B	AVSS0.75f	CN-107F	┌───┐	CN-16F
E10	B	AVSS0.75f	CN-107F	┌───┐	CN-44F
E11	B	AVSS0.5f	CN-107F	┌───┐	CN-10F
E12	B	AVSS0.5f	CN-29F	┌───┐	CN-10F
E30	B	AVSS0.5f	CN-107F	┌───┐	CN-2F
E21	B	AVSS1.25	CN-107F	┌───┐	P-23
E84	B	AVSS0.75f	M-4	┌───┐	P-23
E29	B	AVSS2	P-25	┌───┐	CN-129F

CONNECTORS SELECTION TABLE

CONNECTOR NAME (PIN NUM)	MANUFUC.	PART NUMBER	
		HOUSING	TERMINAL
14FA-040M1	AMP	917531-1	173661-1
18FA-070M1	AMP	173663-1	173631-1
20FA-070M1	AMP	174952-1	173631-1
6FA-070M2	AMP	174923-1	173631-1
2FA-CNA	AMP	172130-1	170032-2
3FA-CNA	AMP	172132-1	170032-2
4FA-CNA	AMP	172134-1	170032-2
8FA-CNA	AMP	172136-1	170032-2
10FA-CNA	AMP	172138-1	170032-2
10MA-CNA	AMP	172137-1	170340-1
4FA-CNA_BR	AMP	172134-2	170032-2
4FA-CNA_BR	AMP	172134-3	170032-2
2FA-JM2	AMP	174352-2	171662-1
2FA-JM2+C	AMP	174352-2	171662-1
6FA-JM2+C	AMP	174262-2	171662-1
		174264-2	
CA104	AMP/YAZAKI	170887-1 (AMP) 7120-8012 (YAZAKI)	170002-5
CB104	AMP/YAZAKI	170889-1 (AMP) 7120-1010 (YAZAKI)	170003-5
CB103	AMP/YAZAKI TOYOTANSHI	170889-1 (AMP) 7120-1010 (YAZAKI)	170012-2
2FM-RS	MTSUBISHI	PE295-02120	MT095-76050
4FB-VF7	P&B	VC7-1000	42281-1 280756-4
6FS-090	SUMITOMO	6242-5061	8240-4422
6FS-DL090	SUMITOMO	6195-0021	8100-1427 8100-1429
2FS-DL305	SUMITOMO	6195-0060	8100-0498
2FS+M090	SUMITOMO	6090-1001	8240-4422
5FS-MITSUBA	SUMITOMO	6098-1493	1500-0207 8240-4242
20FS-SHM090_B	SUMITOMO	6400-0012 6409-0071	8240-4422

23.3.13.1 HARNESS (3/4) : PX11E01050P3

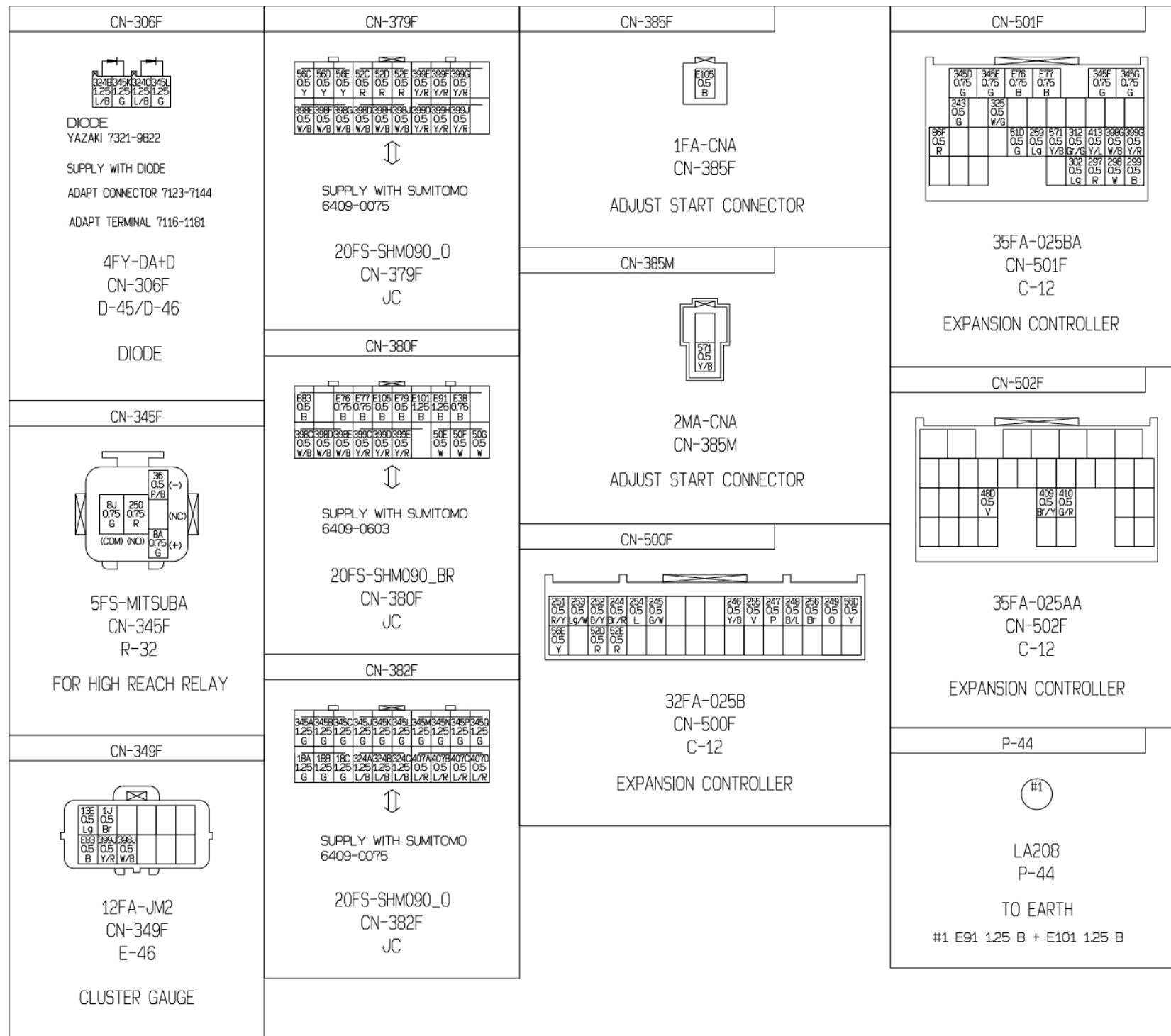

23.3.16.1 HARNESS : PX15E01003P2

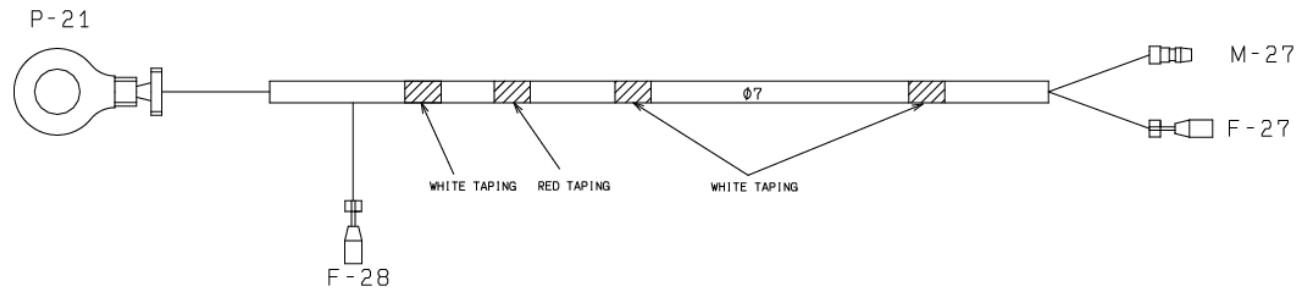

CONNECTORS SELECTION TABLE

CONNECTER NAME (PIN NUM)	MANUFUC.	PART NUMBER	
		HOUSING	TERMINAL
CA104	AMP/YAZAKI	170887-1 (AMP)	170002-5
		7120-8012 (YAZAKI)	
CB104	AMP/YAZAKI	170889-1 (AMP)	170003-5
		7120-1010 (YAZAKI)	

WIRE NO	WIRE COLOR	WIRE SIZE (mm ²)	FROM	CONNECTION	TO
86C	R	AVSS1.25f	F-28	—————	M-27
E35	B	AVSS1.25f	P-21	—————	F-27

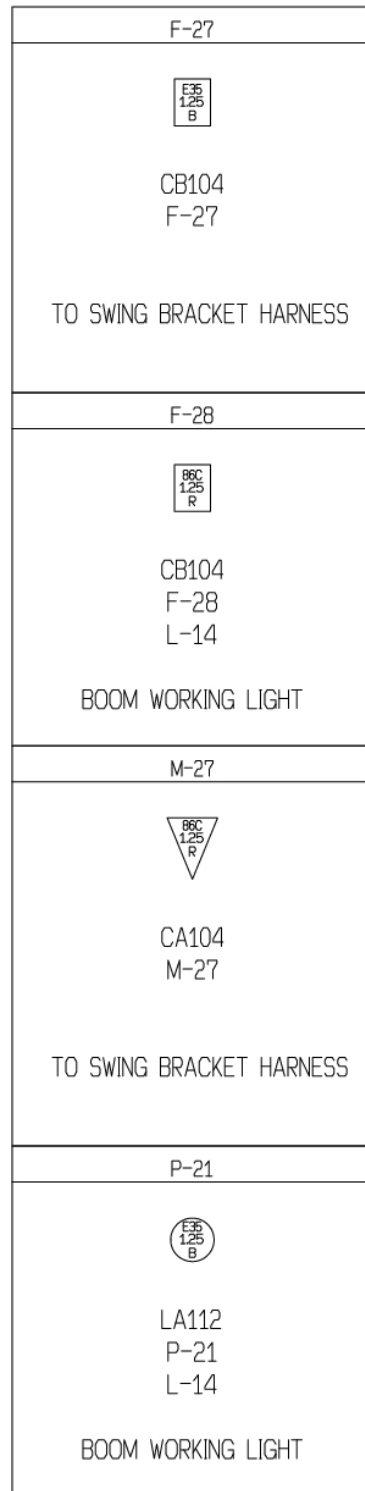

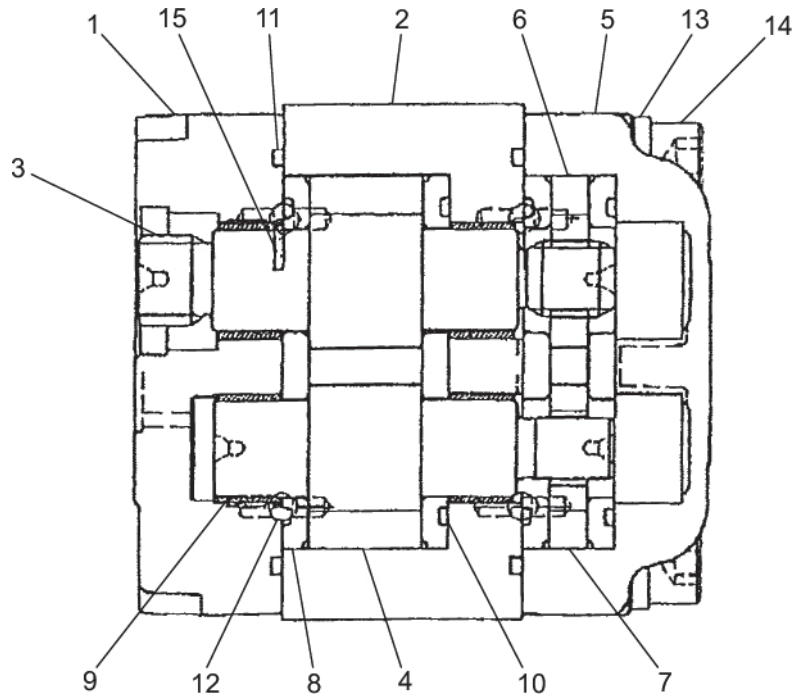

Gear pump structure

Gear Pump

No.	Name	Q'ty	No.	Name	Q'ty
1	Cover front	1	9	Bushing	4
2	Body	1	10	3-shaped gasket	4
3	Drive gear	1	11	Gasket	2
4	Driven gear	1	12	Steel ball	4
5	Body	1	13	Quenching washer	4
6	Drive gear	1	14	Hex head socket bolt	4
7	Driven gear	1	15	O-ring	1
8	Side plate	4			

2. Damping mechanism

(1) In case of neutral position,

Push rod (214) is pushed up by damping spring (336) through piston (224), and holds at the position shown in Fig. "Pilot valve-Sectional view".

(2) Where the control section is inclined from the neutral position,

By rotating the cam clockwise, the push rod on the port 1 side is pushed down, and the piston also moves down.

Then, the oil in the damping piston chamber is discharged through the orifice, and the simultaneously generated pressure produces damping force.

On the other hand, the push rod on the port 2 side moves up by the damping spring through the piston.

Then, oil is sucked from the tank into the damping piston chamber through three ball check valves. The oil outside of the piston chamber flows out through the passage leading to port T on the casing top end.

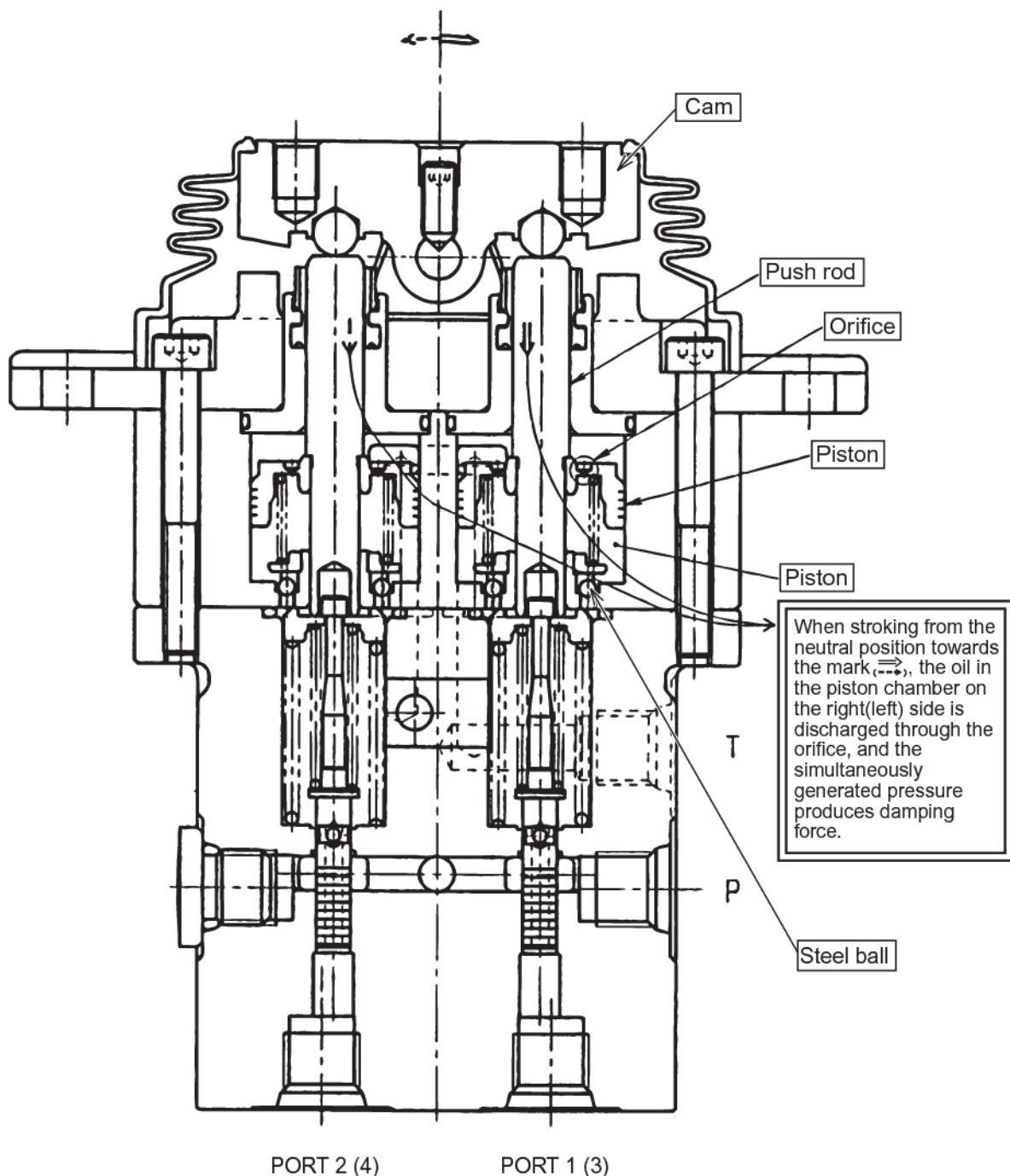

Operation when the lever is stroked from the neutral position

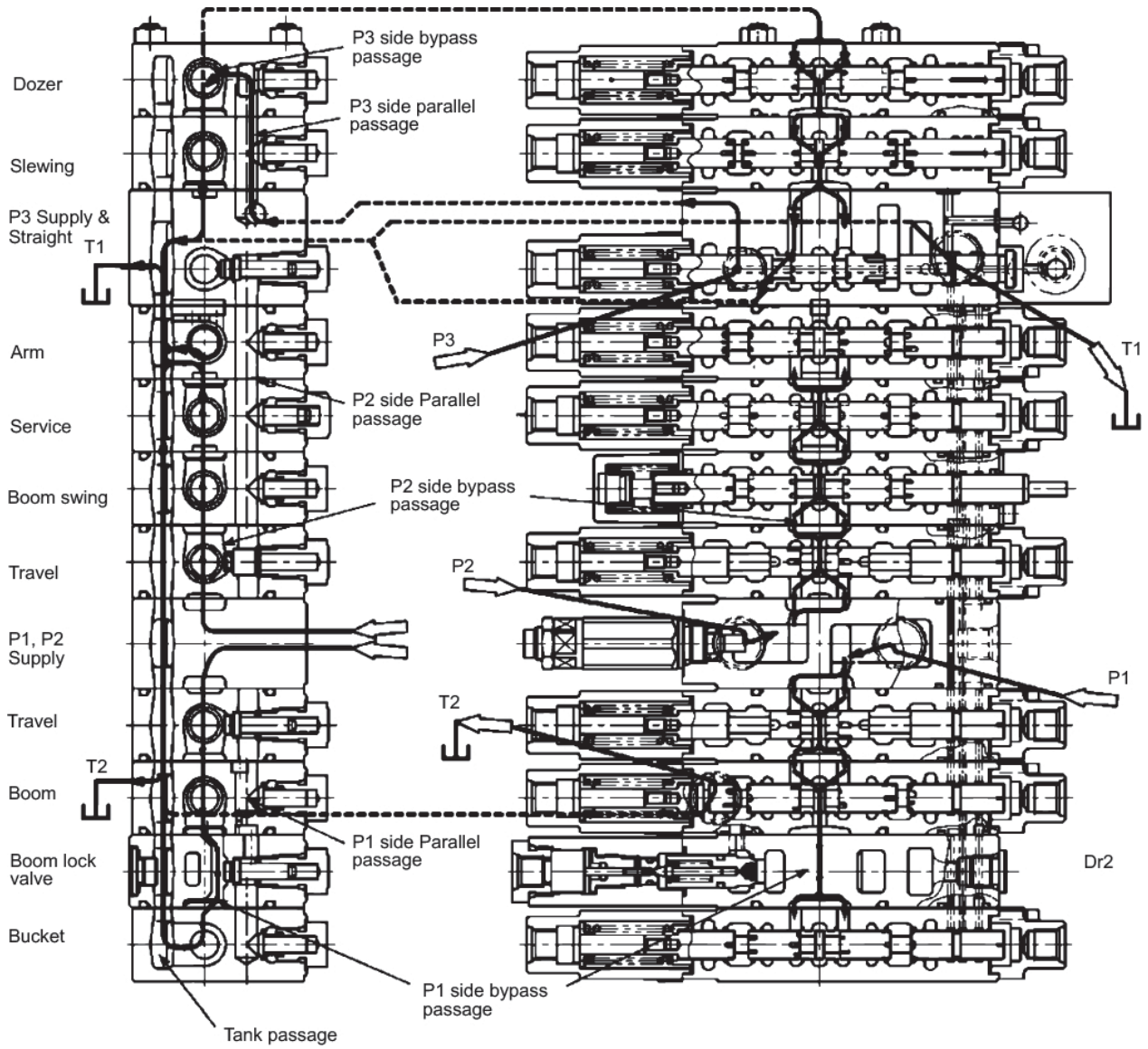

Hydraulic oil flow in neutral

2. Left swing operation

Explanation starts from a condition in which the spool is pushed in.

Since the P2 side Bypass Passage is shut off at the Boom Swing Comp. after the Boom Swing Spool changeover, the oil flowed from P2 port through the P2 side Parallel Passage flows into B5 port through the Load Check Valve in the Boom Swing Comp. and the Bridge Passage since B5 port and the Bridge Passage have been opened after the Spool changeover and then into the Head side of the Boom Swing Cylinder.

On the other hand, the oil returned from the Rod side of the Boom Swing Cylinder flows into A5 port to the Tank Passage that has opened with the Spool's notch after the Spool changeover.

Then, the Boom Swing Cylinder extends to swing the attachment left.

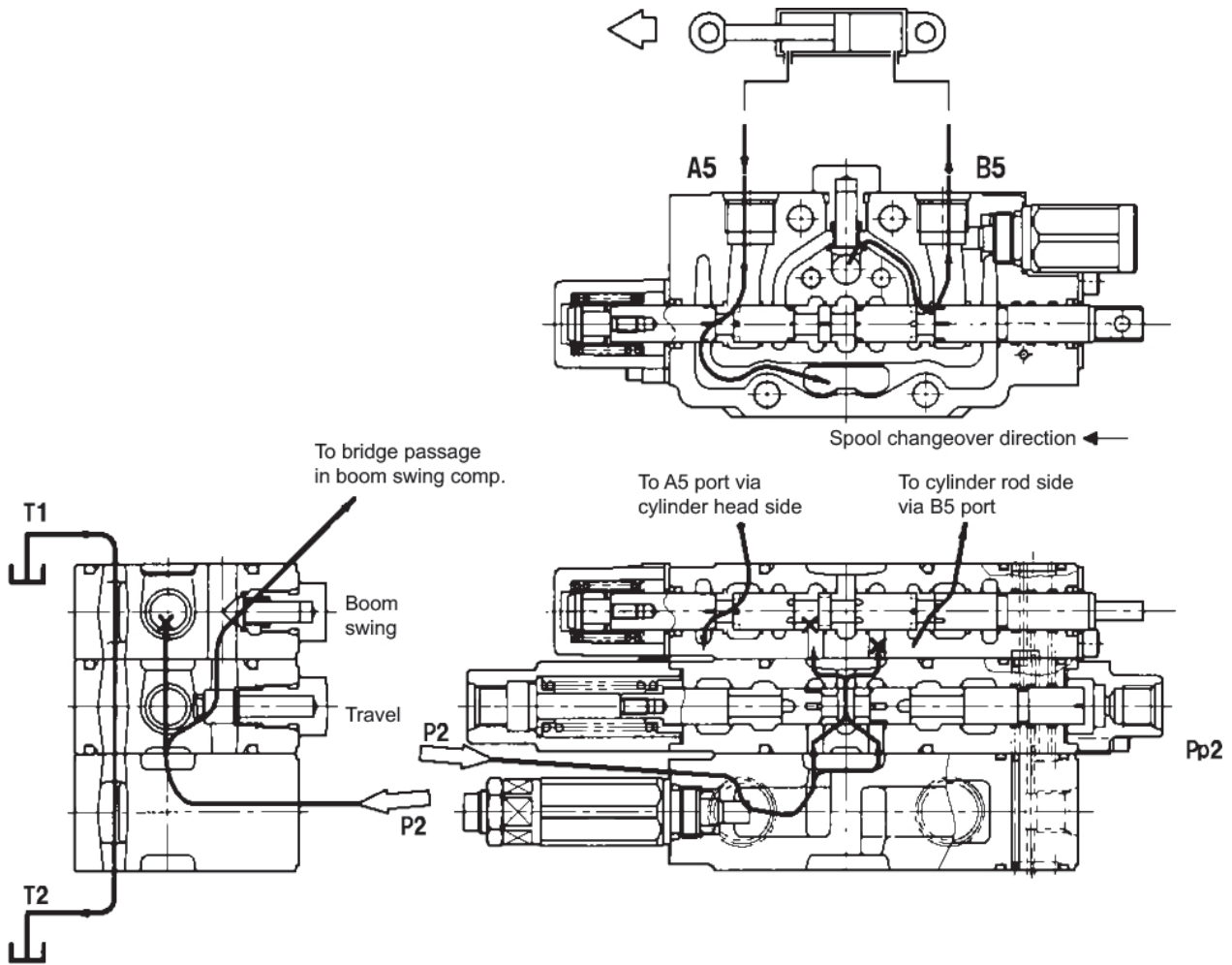

Left swing operation

2. Overload relief valve operation (1)

- a. Pressure oil flows through the inside of the Piston built in the Pressure Regulating Valve (Popet-Main V') and the Orifice B and then into the internal A Chamber until it is filled up. The filled up pressure causes both of the Pressure Regulating Valve and Socket and the Socket and Body Seat to be seated surely.

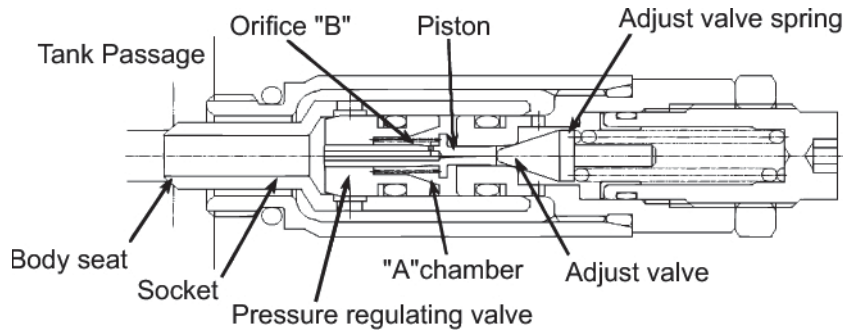

- b. When the oil pressure at port P increases up to the setting pressure of Regulating Valve Spring, the pressure oil is applied to the Regulating Valve via the Piston to open the Regulating Valve. Then, the pressure oil flows through a passage in the direction of Piston inside → Orifice B → A Chamber → Circular Orifice C → Drill Hole D and the external of Socket and then into the Tank Passage.

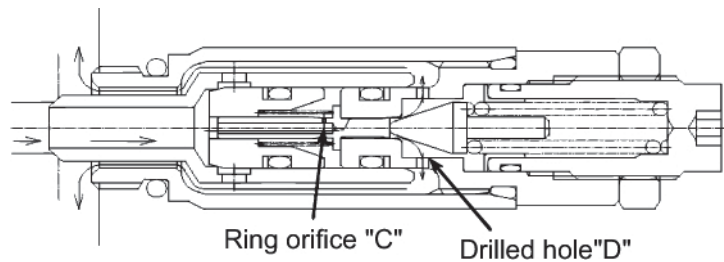

- c. Since the pressure inside the A Chamber decreases when the Regulating Valve is opened, which causes the Pressure Regulating Valve to open to let the pressure oil at port P flows into the Tank Passage through Drill Hole E.

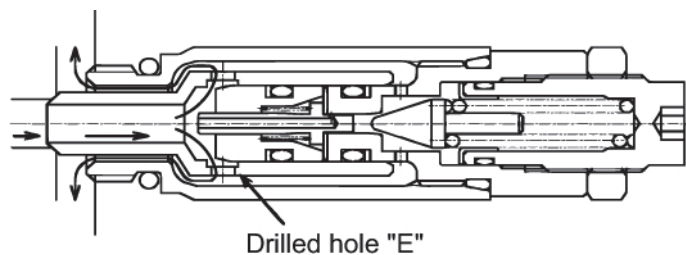

- d. Also, since the Regulating Valve is pressed to the Seat by Regulating Valve Spring when the pressure at port P decreases below the setting pressure of Regulating Valve Spring, the pressure inside A Chamber becomes the same as the pressure at port P to cause the Pressure Regulating Valve to be pressed to the Seat, resulting in the original condition (a)

[24. COMPONENTS SYSTEM]

3. Action of hydraulic parking brake (P/B) timer
 When the parking brake operates as the upper structure produces inertia, the hydraulic parking brake timer operates to delay the operation of the parking brake for a certain time length.

a. When the parking brake is released ;
 If the pressure flows into the brake release command secondary pilot pressure port (PP), it overcomes the force of spring (505) and pushes spool (502) to the positions in Fig. "Operation of hydraulic parking brake timer" and in the figure. On that occasion, the brake release pressure at the brake releasing primary pressure port (PB) passes through the arrow in Fig. "Operation of hydraulic parking brake timer" is flowed into the chamber of the parking brake piston, and releases the parking brake.

b. When the parking brake acts ;
 If the pilot pressure at the brake releasing command secondary pilot pressure port (PP) is blocked, spool (502) is pushed back to the position in the figure by the force of spring (505). The brake release pressure at the brake releasing pressure port (PB) is blocked by spool (502) and block the pressure supply to the chamber of the parking brake piston. The pressure of the parking brake piston chamber is pushed out by the force of the spring in the parking brake and flows out to the DR port through the passage indicated by an arrow in the figure : On that occasion, the oil that is flowing out is regulated by the orifice of piston (503), flows out to the DR port slowly, and delays the action of the parking brake for a certain time length.

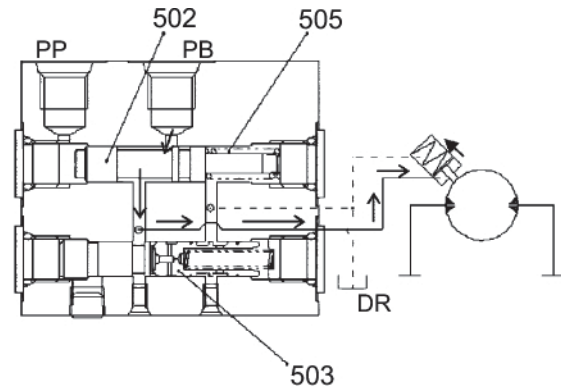

When the brake releasing command secondary pilot pressure flows into port PP ;

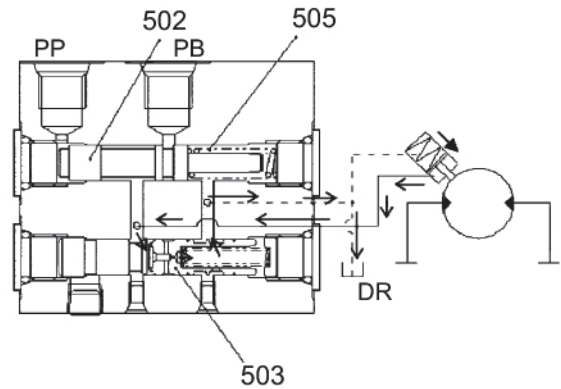

When the brake releasing command secondary pilot pressure is blocked at port PP ;

Operation of hydraulic parking brake timer

24.1.6.5.3 HYDRAULIC VALVE

(1) Counterbalance Valve

The pressure oil from the port A presses and opens check valve (3) to inflow to the port A' on the inlet side of the hydraulic motor. Also, the pressure oil inflows to the D room through the choke hole C and exceed spring (4) force to move spool valve (2) to the right. This makes the hydraulic motor return oil inflow from the port B' and return to the port B through the opening E of body (1) and spool valve (2) to rotate the hydraulic motor. When the pressure oil is provided from the port B, the each of above-mentioned parts operate reversely and the hydraulic motor rotates reversely. Then, when the pressure oil of the port A is blocked, spool valve (2) moved to the right begins to move back to the left by the spring (4) force. At this time, the oil in the D room controls the speed of spool valve (2) moving back to the left by the throttle of the choke hole C. The hydraulic motor still rotates due to the inertial force even though the pressure oil from the port A is blocked. At this time, the switching speed and notch of spool valve (2) controls the return oil gradually to stop the hydraulic motor smoothly.

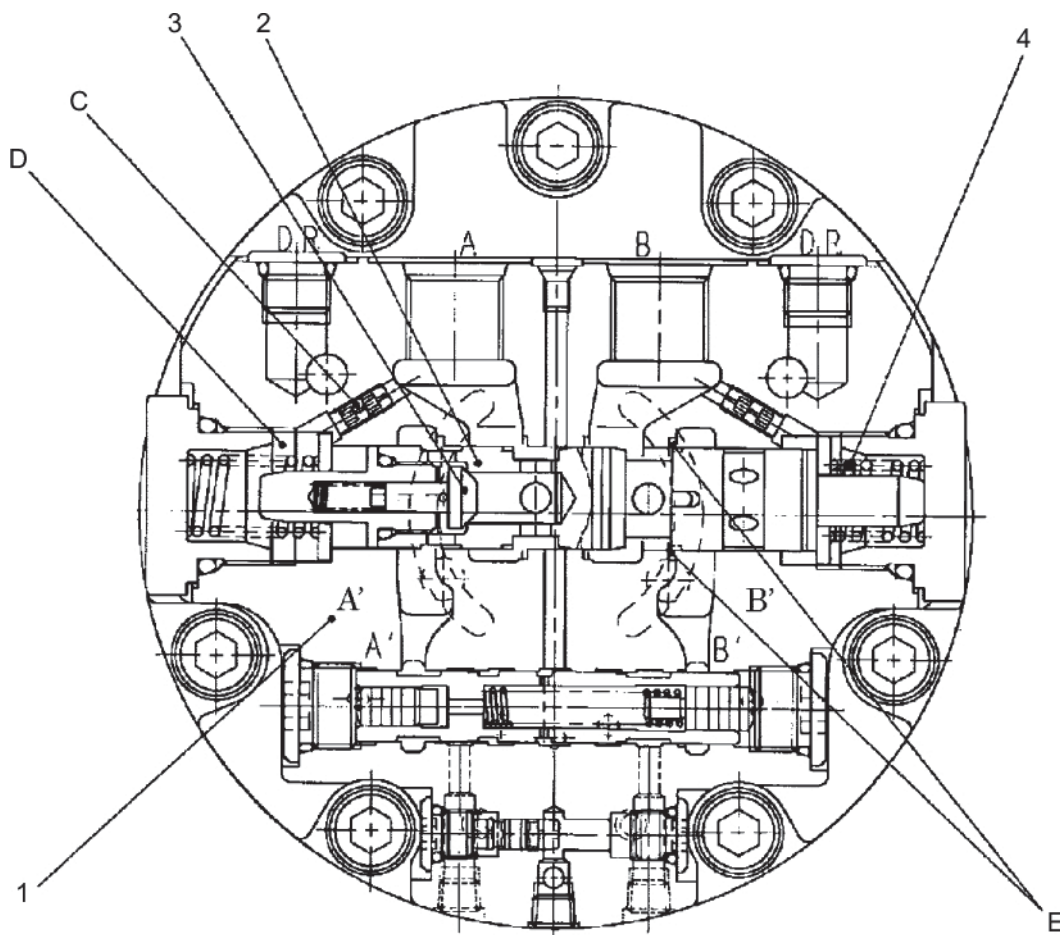

[24. COMPONENTS SYSTEM]

(5) Dozer cylinder

T=Tightening torque; N·m (lbf·ft)

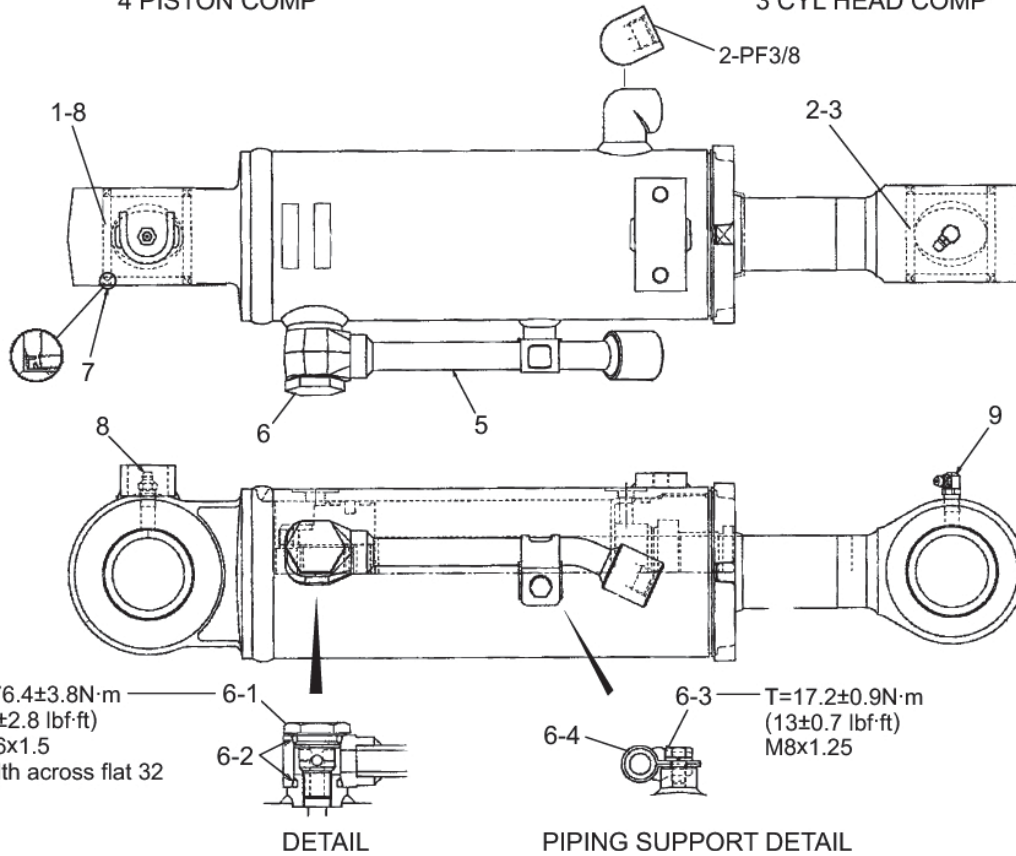
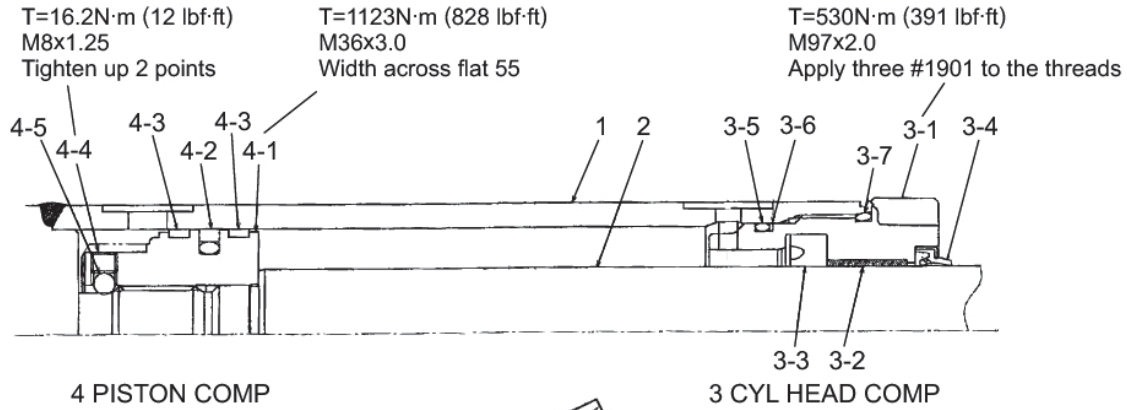

DETAIL PIPING SUPPORT DETAIL
Construction

No.	NAME	Q'TY	No.	NAME	Q'TY	No.	NAME	Q'TY
1	Tube assy	1	3-6	Back-up ring	1	5-2	Joint	1
1-8	Pin bushing	1	3-7	O-ring	1	5-3	Joint	1
2	Rod assy	1	4	Piston COMP	1	6	Plug COMP	1
2-3	Pin bushing	1	4-1	Piston	1	6-1	Plug	1
3	Cylinder Head COMP	1	4-2	Seal ring assy	1	6-2	O-ring	1
3-1	Cylinder head	1	4-3	Slide ring	2	6-3	Upset bolt	1
3-2	Bushing	1	4-4	Set screw	1	6-4	Pipe holder	1
3-3	U-ring	1	4-5	Steel ball	1	7	Dust seal	4
3-4	Wiper ring	1	5	Tube assy	1	8	Grease nipple	1
3-5	O-ring	1	5-1	Tube	1	9	Grease nipple	1

[24. COMPONENTS SYSTEM]

Code No. Parts Name Parts No. Use Applicable Machine	Specifications	Description
--	----------------	-------------

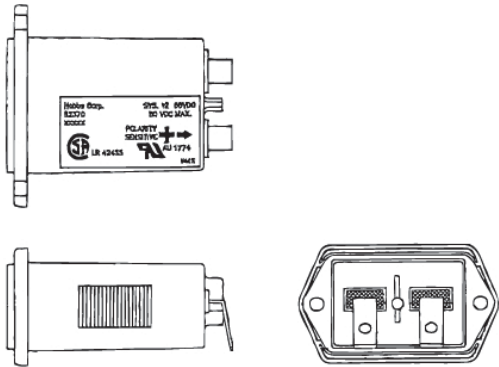
E-26	<table border="1"> <tr> <td>Movement</td> <td>Quartz</td> </tr> <tr> <td>Rated voltage</td> <td>DC12 ~ 60V</td> </tr> </table>	Movement	Quartz	Rated voltage	DC12 ~ 60V	
Movement	Quartz					
Rated voltage	DC12 ~ 60V					
Hour meter						
PX58S00004P1						
PS03-05001~ PX16-30001~ PW15-50001~ PD03-05001~						

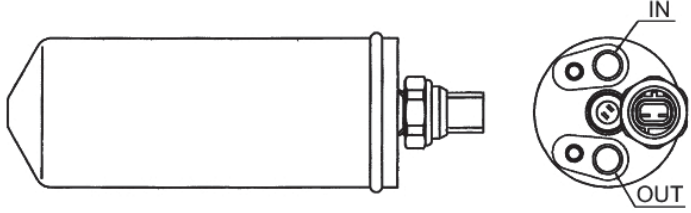
E - 27	<table border="1"> <tr> <td>Maker</td> <td>Sanden Corp</td> </tr> <tr> <td>Model</td> <td>51440-A1290</td> </tr> </table>	Maker	Sanden Corp	Model	51440-A1290	
Maker	Sanden Corp					
Model	51440-A1290					
Receiver dryer						
PY20M01300F1						
Air-con PS03-05001~ PX16-30001~ PW15-50001~ PD03-05001~						

E-44, 49, 53	<table border="1"> <tr> <td>Maker</td> <td>DEUTSCH JAPAN LIMITED.</td> </tr> <tr> <td>Maker Part No.</td> <td>DT04-3P-P006</td> </tr> </table>	Maker	DEUTSCH JAPAN LIMITED.	Maker Part No.	DT04-3P-P006	
Maker	DEUTSCH JAPAN LIMITED.					
Maker Part No.	DT04-3P-P006					
Resistor 1,2 (120Ω) Resistor 6 (120Ω)						
PY26E01001P1						
Gauge cluster LCD:(OPT.) PX16-30001~ PX17-40001~ PW15-50001~ PD03-05001~						

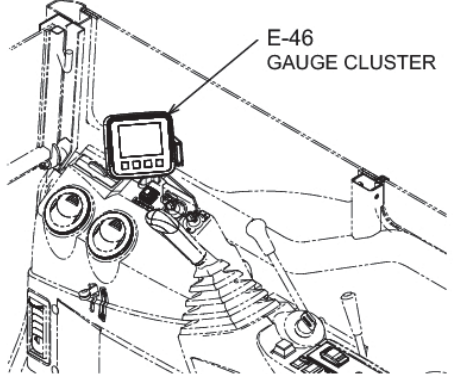
E-46	<table border="1"> <tr> <td>Maker</td> <td>TOKAI RIKI CREATE CORPORATION</td> </tr> <tr> <td>Rated voltage</td> <td>12V</td> </tr> <tr> <td>Flash Rom size</td> <td>16M Byte</td> </tr> </table>	Maker	TOKAI RIKI CREATE CORPORATION	Rated voltage	12V	Flash Rom size	16M Byte	
Maker	TOKAI RIKI CREATE CORPORATION							
Rated voltage	12V							
Flash Rom size	16M Byte							
Monitor								
PS59S00001F2								
Gauge cluster (OPT.) PS04-10001~ PX16-30001~ PX17-40001~ PW15-50001~ PD03-05001~								

[24. COMPONENTS SYSTEM]

Code No. Parts Name Parts No. Use Applicable Machine	Specifications	Description
--	----------------	-------------

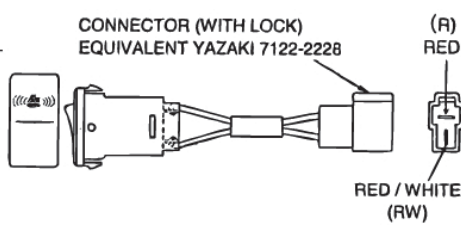
SW-23	Type	Single-pole single-throw (Alternate)										
Switch	Rated voltage	DC24V										
2479U1190F16	Insulation resistance	More than 1MΩ / 500V megger										
Travel alarm select switch	TERMINAL CONNECTION <table border="1" data-bbox="446 537 766 672"> <thead> <tr> <th>Terminal Position</th> <th>R</th> <th>RW</th> </tr> </thead> <tbody> <tr> <td>OFF</td> <td></td> <td></td> </tr> <tr> <td>ON</td> <td>○</td> <td>○</td> </tr> </tbody> </table>		Terminal Position	R	RW	OFF			ON	○	○	
Terminal Position	R	RW										
OFF												
ON	○	○										
PS03-05001~ PS02-00101~ PX16-30001~ PW15-50001~ PD03-05001~												

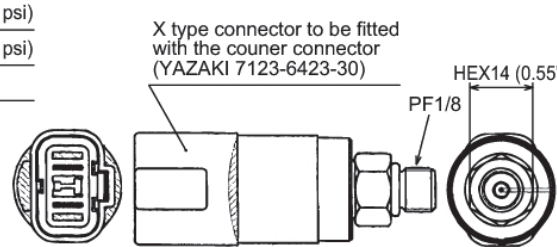
SW-25, 27	Maker	SAGINOMIYA SEISAKUSHO INC.	
Switch	Maker's P/No.	HCB-KMA25	
PS50S00001F1	Working pressure	539±49kPa (78.2±7.1psi)	
Travel alarm	Release pressure	343±49kPa (49.7±7.1psi)	
PX16-30001~ PW15-50001~ PD03-05001~	Point of contact from	Normally open	

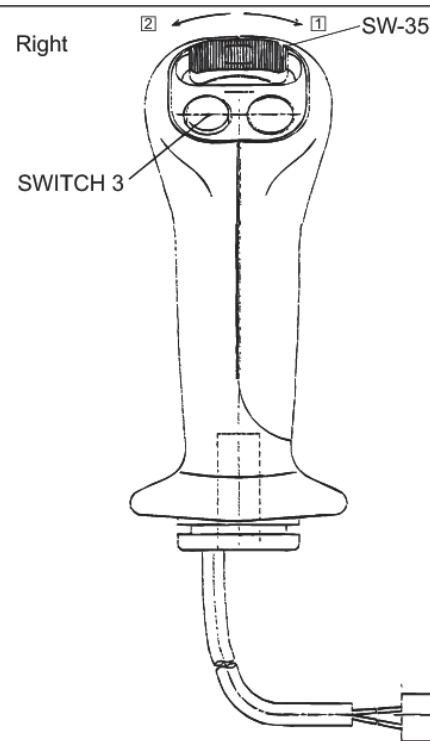
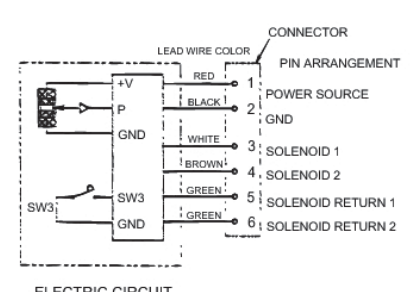
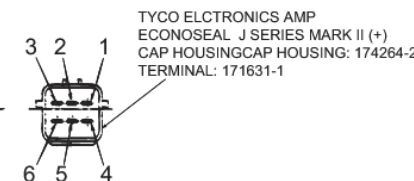
SW-35	Right	SW-35	
Grip & Switch			
PW03M01958F1			 <p>ELECTRIC CIRCUIT</p>
Nibbler open-close SW. (OPT.)			
PW14-45964~ PX15-20658~ PV13-33292~ PJ06-08890~ PJ06-09807~ PS02-00101~ PS04-10001~ PX16-30001~ PX17-40001~ PW15-50001~ PD03-05001~			 <p>TYCO ELECTRONICS AMP ECONOSEAL J SERIES MARK II (+) CAP HOUSINGCAP HOUSING: 174264-2 TERMINAL: 171631-1</p>

(2) RECEIVER DRYER

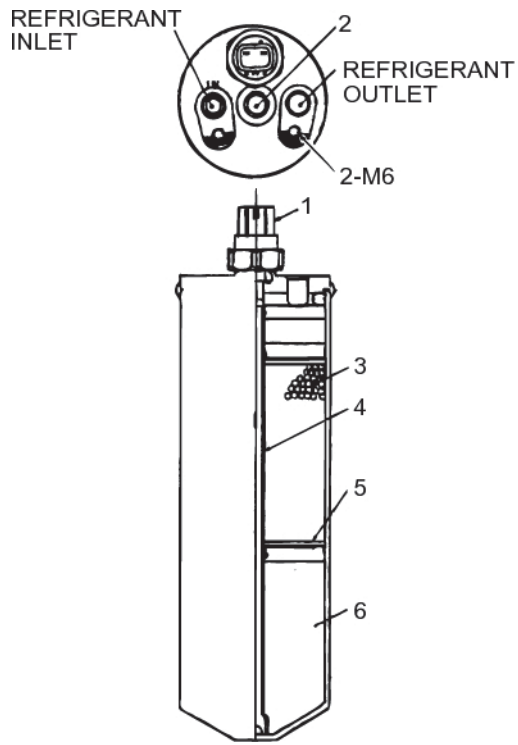

No	NAME	Q'TY
1	PRESSURE SWITCH	1
2	SIGHT GLASS	1
3	DESICCANT	1
4	SUCTION PIPE	1
5	FILTER	1
6	RECEIVER TANK	1

Receiver dryer

[25. AIR-CONDITIONER SYSTEM]

(5) TEMPERATURE ADJUSTMENT SWITCH (THERMOSTATIC VOLUME)

Rotating the knob changes the on/off point of the compressor and the aperture of the warm water valve, and that adjust the air temperature from the evaporator or heater core and thus adjust the outlet air temperature from the air conditioning unit.

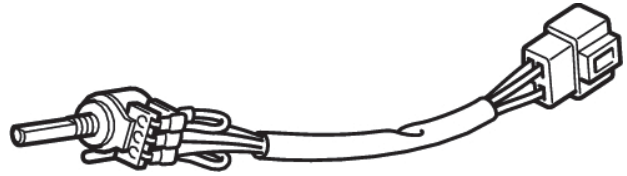

INSPECTION OF TEMPERATURE ADJUSTMENT SWITCH

Terminals for Measurement	Resistance Value Between Terminals	
	COOL — MAX → Median Value	Median Value → HOT — MAL
Between Y/W and Y/B	About 2.3k Ω → About 0 Ω	Stays about 2.3k Ω
Between Y/W and G/W	Stays about 2.3k Ω	About 2.3k Ω → About 0 Ω

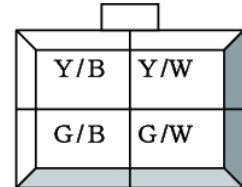

(3) BLOWER MOTOR DOES NOT ROTATE

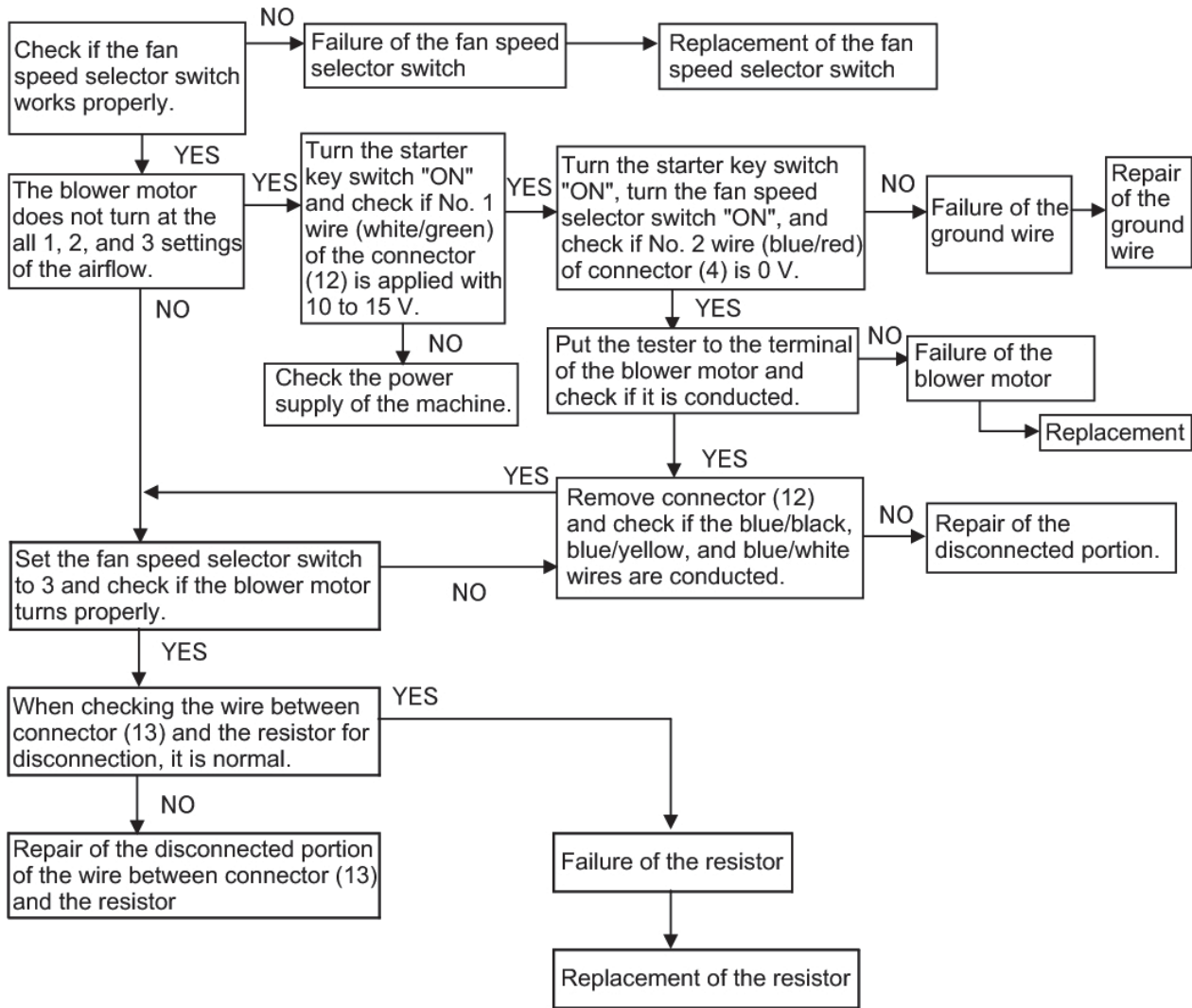

Note

1. If the blower motor has an obvious failure, inspect it first.
2. After repairing, be sure to connect the connectors which were removed for inspection.

32.1.2 BUCKET

32.1.2.1 REMOVING BUCKET

- (1) Operate the control lever to lower the bucket to the ground to avoid load on the connecting pins between the bucket and arm.
- (2) Move O-ring (3) to the bucket boss side using a spatula.

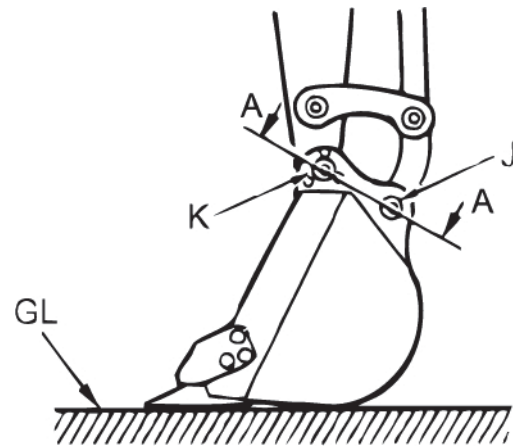

Lowering bucket to ground

- (3) Remove ring (2) and pin (1) with a flat-head screwdriver to remove pin (K) between the arm and bucket.
 - If it is difficult to remove the pin, it is because a load is applied to it. Operate the control lever to adjust the bucket position.
 - Be careful not to damage the dust seal between the arm and bucket boss.
- (4) Operate the control lever so as to release a load on pin (J) between the bucket link and bucket.
- (5) Remove ring (2) and pin (1) and remove pin (J).
- (6) Remove the bucket assy.
 Bucket assy mass:
 76kg (168 lbs)

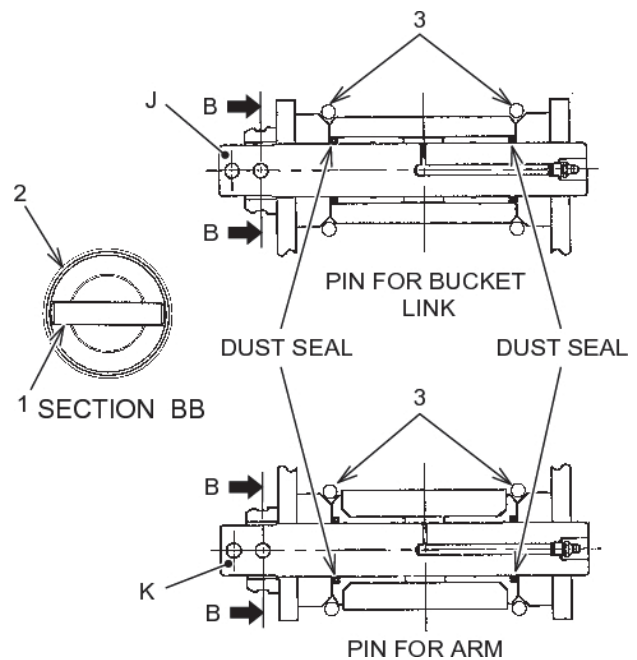

Pin mounting area (cross section A-A)

32.1.6 BOOM SWING

32.1.6.1 PREPARATION FOR REMOVAL/INSTALLATION

- (1) Boom swing the machine left by about 30 degrees to improve the workability.
- (2) Remove the cylinder hoses of the bucket, arm and boom, and plug their connection ports.

Tools: Wrench: 19, 22, 27mm

32.1.6.2 REMOVING BOOM SWING BRACKET AND CYLINDER

(1) Removing boom swing bracket (A9)

1. Remove retaining sems bolt (C5) of rod side pin (M) of boom swing cylinder (C11), and then remove pin (M).

Tools: Socket: 17mm

2. Attach and retain boom foot pin (A) to the original position of boom swing bracket (A9), and then lift the boom swing bracket temporarily.

3. Remove retaining capscrews (B8) and (B9) of boom swing center pins (L1) and (L2), and then remove pins (L1) and (L2).

Tools: Socket: 17, 19mm

4. Remove boom swing bracket (A9).

Boom swing bracket mass: 69kg (152 lbs)

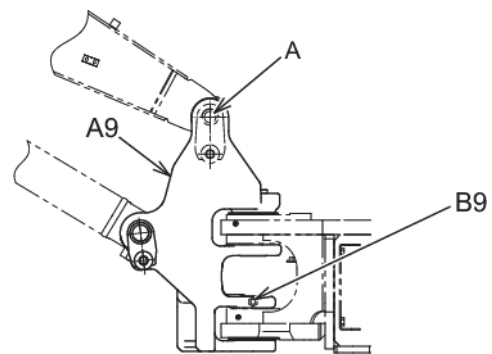
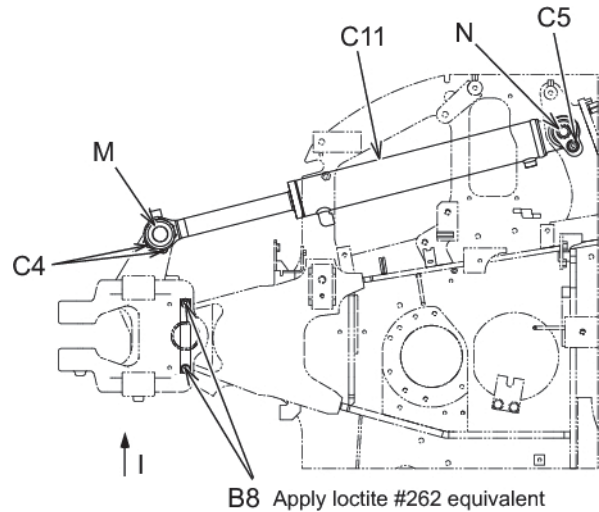

(2) Removing boom swing cylinder (C11)

1. Remove the two boom swing cylinder connection hoses.

Tools: Wrench: 19, 22mm

2. Remove retaining capscrew (C5) of head side pin (N) of boom swing cylinder, and then remove pin (N).

Tools: Socket: 19mm

3. Take out boom swing cylinder (C11) from the front.

Boom swing cylinder mass: 28kg (62 lbs)

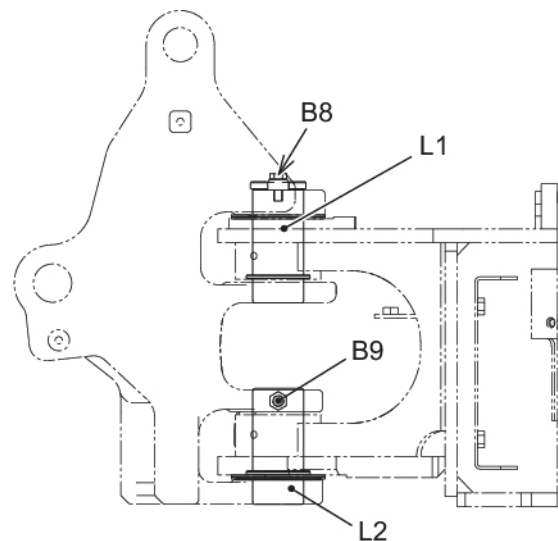

VIEW I
Boom swing

[32. ATTACHMENTS]

2. Installing U-Ring
Install the U-ring (6).

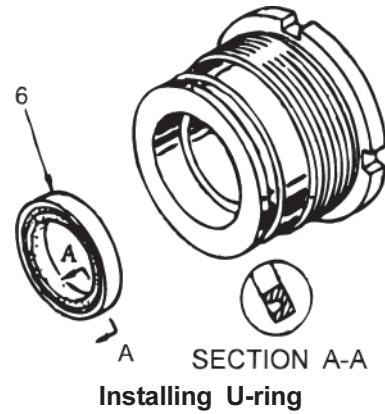

3. Assembling holder (Only for boom cylinder)
 - a. Install spacer (12).
 - b. Install cushion seal (13).
 - c. Install collar (14).
 - d. Install back-up ring (16) and O-ring (8).

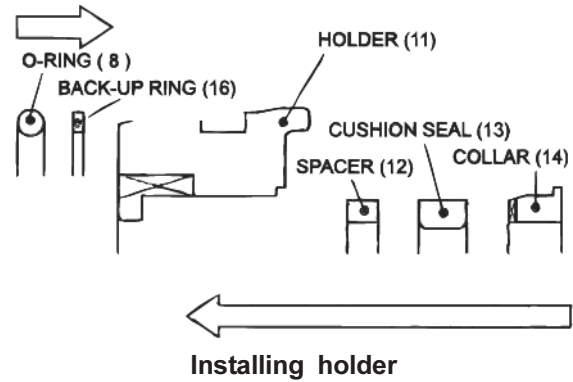

4. Using the setting tool, install the wiper ring (7).

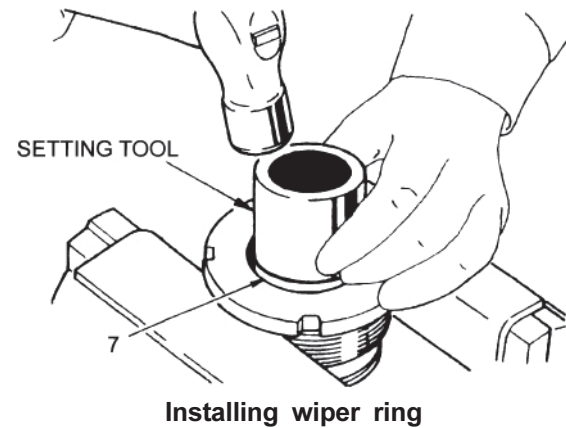

5. Install the back-up ring (9) and O-rings (8) and (10).

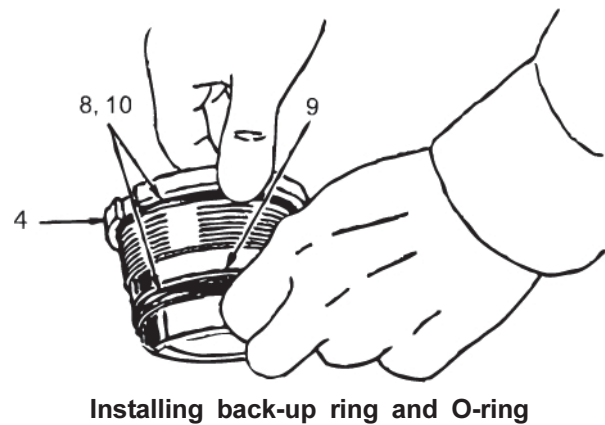

33.1.3 FLOOR PLATE ASSEMBLY

The travel pilot valve assembly and boom swing foot pedal are integrated with the floor plate. They have to be removed/installed together.

33.1.3.1 PREPARATION FOR REMOVAL OF FLOOR PLATE ASSEMBLY

- (1) Remove floor mats (3) and (4).
(See Paragraph 33.1.1)
- (2) Remove the canopy or cab.
(See Paragraph 33.1.1)
- (3) Remove six semi bolts (5) M8 x 20 and floor plate (2).
Tools: Socket: 13mm
- (4) Separate the electric wiring for the travel speed select switch at the connector part.
If the machine is equipped with the travel alarm, remove the four pressure switch connectors attached to the travel pilot valve.

Canopy

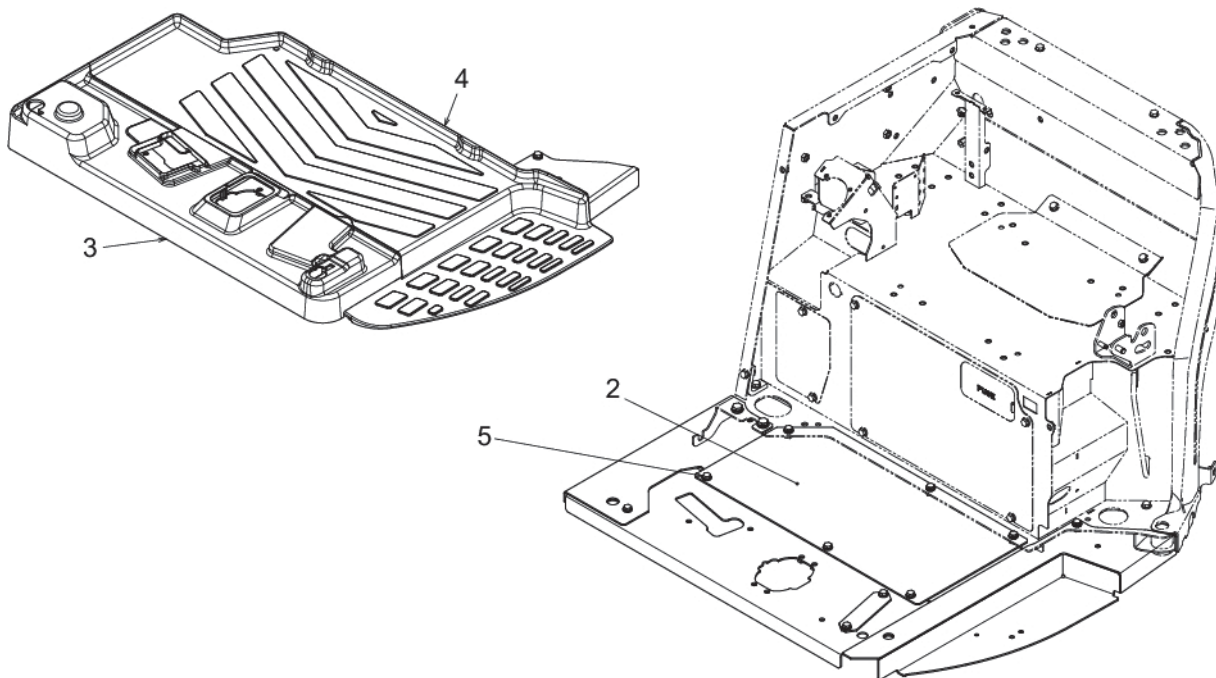

Removing floor plate

[33. UPPER STRUCTURE]

(2) Removing cable

1.
Remove pin (9) and then pin (8).
2.
Disconnect boom swing cable (6).

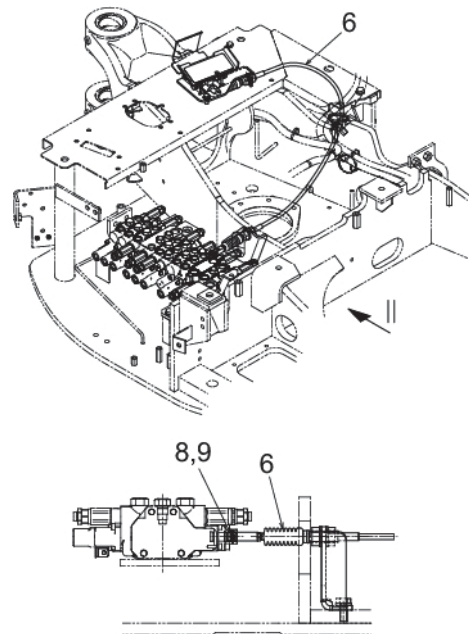

VIEW II

Removal/installation of cable

(3) Removing the control valve

1.
Loosen four sems bolts (A4) M10 x 35 and remove control valve (A1) in combination with bracket (A2).

Tools: Socket: 17mm

Mass of removed part: Approximately 30kg (66 lbs)

- 2.

Loosen three sems bolts (A3) M10 x 25 and remove control valve (A1).

Tools: Socket: 17mm

Mass: Approximately 25kg (55 lbs)

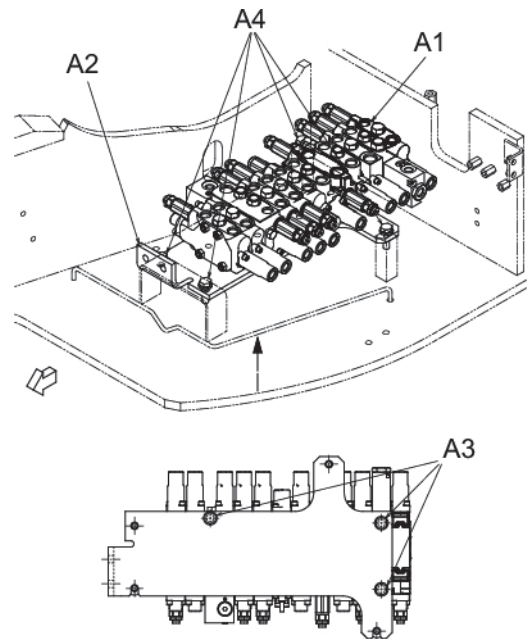

VIEW I

Removal/installation of control valve

33.1.14 MUFFLER

33.1.14.1 PREPARATION FOR REMOVAL

- (1) Remove the guards which need to be removed to remove the muffler. (See Paragraph 33.1.2)
- (2) Remove the counterweight. (See Paragraph 33.1.6)

33.1.14.2 REMOVAL

- (1) Loosen two sems bolts (11) M10 x 35 and remove plate (4). Remove four nuts (17-2, 17-3) M8 and U bolt (6).

Tools: Wrench: 13mm, 17mm

- (2) Loosen nut (18) M10 and remove clamp (5) and exhaust tube (3).

Tools: Wrench: 17mm

- (3) Loosen four nuts (17-1) M8 connecting the muffler to the exhaust manifold of the engine and remove them.

Tools: Wrench: 13mm

- (4) Loosen four sems bolts (9) M8 x 20 and remove muffler (1).

Tools: Wrench: 13mm

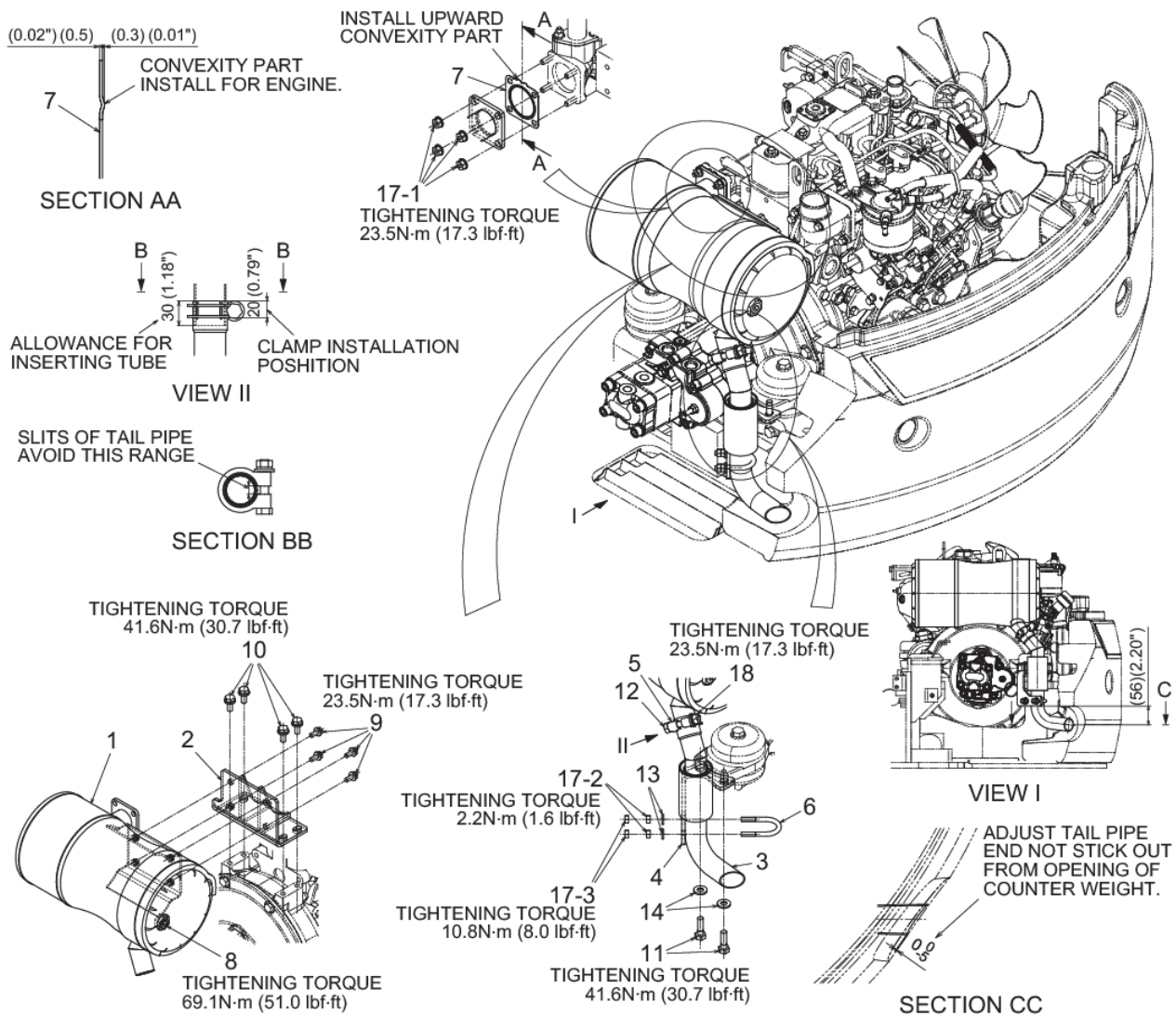

マフラー取外し

[33. UPPER STRUCTURE]

1. Removing engine mounting bolts (9)
Loosen and remove four bolts (9) M12 x 120 which fix the engine to rubber mount (3).
Tools: Socket: 19mm
2. Lifting engine
Sling the engine by using the two sling hooks on the top of engine and lift up the engine.
Mass: Approximately 130kg (287 lbs)
3. Place the engine on the engine cradle in a stable condition.

33.1.18.3 INSTALLATION

- (1) Install the engine in the reverse procedures of removal.
For tightening torques and Loctite, see the table below.

Item	Name	Tools (mm)	Tightening torque N-m (lbf-ft)
7	Sems bolt (M12)	19	121 (89.2) Applying Loctite #262
8	Sems bolt (M12)	19	121 (89.2)
9	Capscrew (M12)	19	79.4 (58.6) Applying Loctite #262

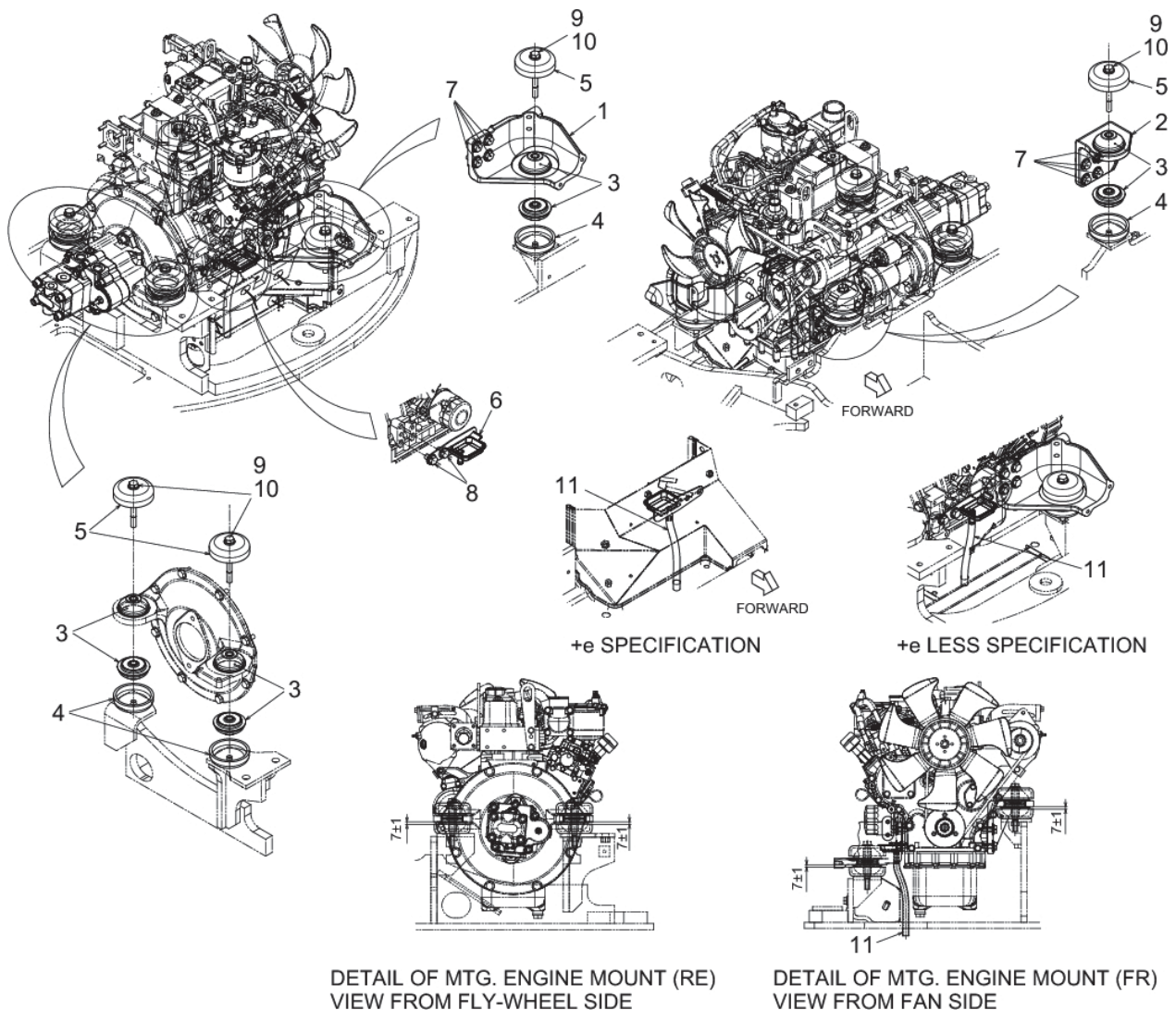

Removal/installation of engine

This page is blank for editing convenience.

[33. UPPER STRUCTURE]

(11) Assembling body S and body H

Attach two bolts M10 x 65 for temporary assembly to the upper two positions and tighten them gently.

When the gap between matching surfaces becomes 5 to 10mm (0.20 to 0.39 in), attach hex head socket bolts (44) M10 x 45 to the remaining three positions.

Replace the bolts for temporary assembly with hex head socket bolts (44) M10 x 45 and tighten the bolts.

Tightening torque:

51.0 to 64.7 N-m (37.6 to 47.7 lbf-ft)

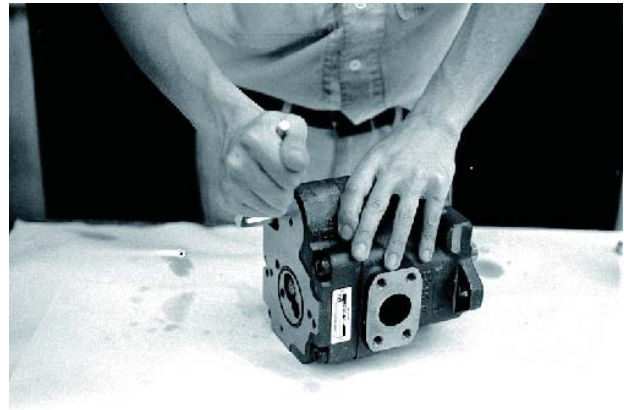

(12) Attaching hex head socket set screw

Adjust hex head socket set screw (60) to the length of protrusion before disassembly and then fix it with hexagon nut (61).

Tightening torque:

14.7 to 19.6 N-m (10.8 to 14.5 lbf-ft)

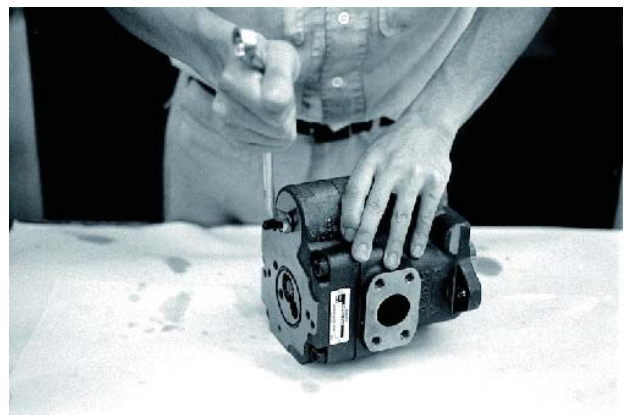

Note

Be sure to replace seal washer (62) with new one.
Not following this may cause oil leakage.

(13) Installing gear pump

Attach O-rings (69), (71) and (72) to the matching surface of body H (2) and gear pump (65).

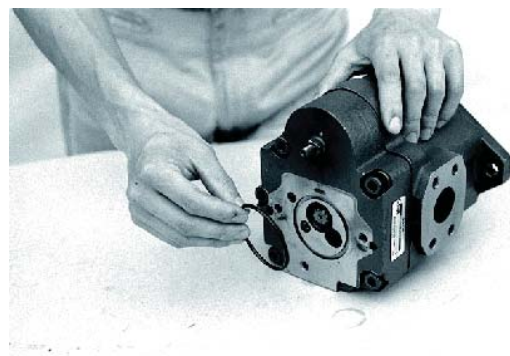

Note

At this time, replace the O-ring with a new one.

[33. UPPER STRUCTURE]

33.2.2.2.3-2 CHECK VALVE DISASSEMBLY PROCEDURES

See Fig. "Check Valve (Dozer, Swing, Arm, Boom Swing, Boom, Bucket)", "Check Valve (P3 Inlet, Travel, Boom Lock Valve)", and "Check Valve (Service)" below.

1. Hold the Control Valve Body at workbench or hold it by two or more people.
2. Loosen and remove Check Valve Plug (6) at the center of the Control Valve upper surface with 19mmScrew Wrench or Socket Wrench.
When it is hard to loosen the Plug because O-Ring (5) bites the screw, do not loosen forcibly; refasten it once and then try to loosen again.
3. From the hole where Check Valve Plug has been removed, remove Check Valve Spring (4) and Check Valve (3) with Tweezers or Magnet.

- The numbers in See Fig. "Check Valve (Dozer, Swing, Arm, Boom Swing, Boom, Bucket)" below are the same as those in the Dozer Comp. in the Specifications and Drawings.

- Except for the Dozer Comp. the shape of Check valve is different; however, they can be disassembled in the same manner.

- The numbers in See Fig. "Check Valve (P3 Inlet, Travel, Boom Lock Valve)" below are the same as those in the Travel Comp. in the Specifications and Drawings.

- The numbers in See Fig. "Check Valve (Service)" below are the same as those in the Service Comp. in the Specifications and Drawings.

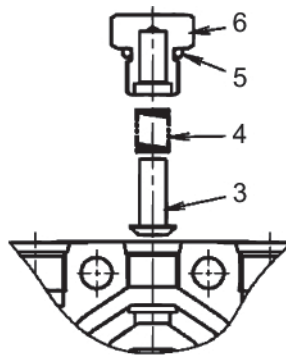

Check Valve
(Dozer, Swing, Arm, Boom Swing, Boom, Bucket)

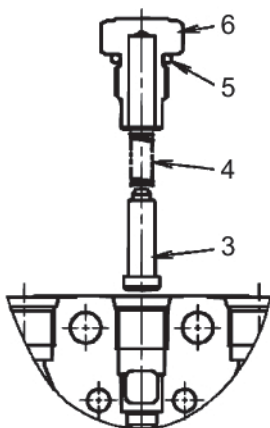

Check Valve
(P3 Inlet, Travel, Boom Lock Valve)

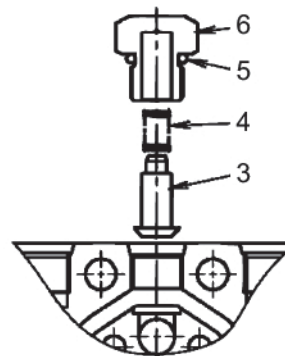

Check Valve
(Service)

33.2.2.3 ASSEMBLY**33.2.2.3.1 PRECAUTIONS FOR ASSEMBLY**

The disassembly and assembly of our products are to be carried out at our factory in principle. If there is a necessity of them unavoidably, observe the following precautions and carry out the work at a factory where there are engineers with sufficient technique for hydraulic devices.

1. Be careful that the unevenness of fastening torque and the contamination of dust during assembly work could result in malfunction.
In addition, observe fastening torque values specified in the Specifications and Drawings.
2. During assembly work, compare Valves with the Specifications and Drawings and check the number of parts whether there is any improper assembly and/or the omission of parts.
3. For the parts to be used in assembly, dip in fluid oil as need arises to reassemble after washing well in washing oil and being dried.
4. After cleaning and degreasing the surface sufficiently, apply LOCTITE to 2 threads of the screw from the tip.
(Too much LOCTITE could result in malfunction after squeezing out.)
5. For the part to be attached or assembled with two or more Bolts and Nuts, fastening them evenly and alternately for several times, not once with the specified torque.
The unevenness of fastening torque could result in the leakage of hydraulic fluid to the outside and/or malfunctions.

33.2.2.3.2 PRECAUTIONS FOR ASSEMBLING SEAL PARTS

1. All seals are to be renewed at assembly.
2. Check seals for defects in molding and flaws in handling.
Do not use the seal with defect and/or flaw.
3. The seals used on sliding surfaces and the places to be installed with seals are to be applied with grease or hydraulic fluid for sufficient lubrication where not specially noted.
4. Do not make seals longer up to permanent deformation.
5. O-Ring is not to be twisted during assembly.
Kinked O-Ring could cause oil leakage after installation because kinks are hard to restore.

33.2.2.3.3 NECESSARY TOOLS AND OTHERS

Before assembling the Control Valve, prepare the following tools.

The tools below are used to assemble this Control Valve only; tools for assembling the port fittings are not included.

NAME	QUANTITY	APPLICATION
Hexagonal Wrench	Each 1	4mm · 5mm · 6mm · 8mm
Screw Wrench	Each 1	13mm · 19mm · 21mm · 22mm · 26mm
Socket Wrench	Each 1	13mm · 19mm · 21mm · 22mm · 26mm
Torque Wrench	1	1.96 to 19.6 N-m (1.4 to 14.5 lbf-ft)
Torque Wrench	1	19.6 to 98.1 N-m (14.5 to 72.4 lbf-ft)
Magnet	1	
Pliers	1	
Slotted Screwdriver	1	
Tweezers	1	

Prepare clean wash oil, hydraulic fluid, grease, and others before work.

33.2.2.3.4-6 SPOOL INSTALLING PROCEDURES

(1) Hydraulic Operation (Except P3 Inlet and Connecting Comp.)

Taking the Swing Spool as an example, the installing procedures are as follows.

(See Fig. "Hydraulic Operation (Except P3 Inlet and Connecting Comp.)" below.)

1. After checking whether there is no dust or the like in the Spool Sleeve of the Body and/or Spool Ass'y and O-Ring (7) is securely installed with that the flange bottom of the Body, insert the Dozer Spool Ass'y into Spool Sleeve of the Body with attention to the position and direction.
 - Then, apply little hydraulic fluid to the Spool before insertion.
 - When there is no feeling of wrongness, move it slowly several times checking the movement and no feeling of wrongness again.

CAUTION

Carefully insert Spool Ass'y into the Spool Sleeve horizontally.

If it is hard to insert, forcible insertion could cause impressions on Spool Sleeve and/or Spool, resulting in malfunction.

If you feel any feeling of wrongness such as catches or strong resistance, pull it out once to check whether there is the adhesion of dust or the development of flaw or burr.

If there are flaws or burrs, there could be malfunction so that replace Body and Spool in set.

2. Press Pilot Cover (9) in a direction from the spring side of Spool Ass'y to the flange of the Body. Fasten 2 Hex. Socket Head Bolts with Washers (10) with specified torque with 4mm Hexagonal Wrench.
3. The other spools can be assembled in the same manner.

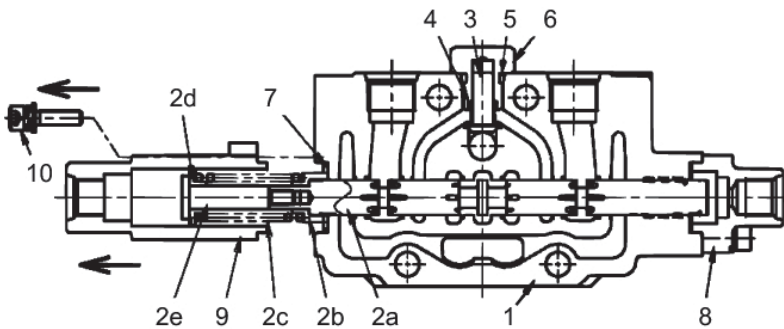

No.	DESCRIPTION
1	BODY-WORK "GE "
2	SPOOL Ass'y (SWING)
a	SPOOL (SWING)
b	SPRING S EAT
c	SPRING
d	SPRING SEAT
e	END-SPOOL
3	POPPET-CHECK VALVE
4	SPRING-CHECK VALVE
5	O-RING 1B P11
6	PLUG-CHECK VALVE
7	O-RING 1B S22
8	PILOT COVER "B1"
9	PILOT COVER "A1"
10	HEX. SOCKET HEAD BOLT WITH WASHER

Hydraulic Operation (Except P3 Inlet and Connecting Comp.)

33.2.3 PILOT VALVE (ATTACHMENT)

33.2.3.1 CONSTRUCTION

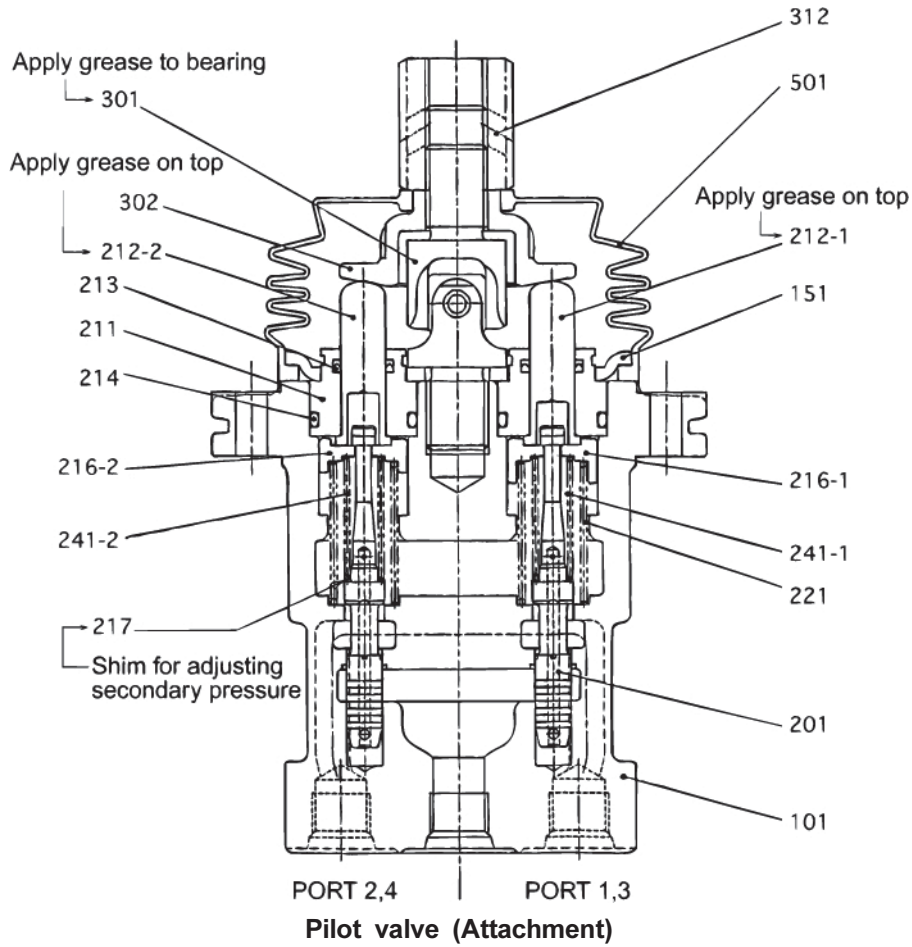

Item	Thread size	Tightening Torque Table N-m (lbf-ft)
301	M14	47.1 (34.7)
302, 312	M14	68.6 (50.6)

Item	NAME	Q'TY	Item	NAME	Q'TY	Item	NAME	Q'TY
101	CASING	1	213	SEAL	4	241-1	SPRING	2
151	PLATE	1	214	O-RING; 1B P20	4	241-2	SPRING	2
201	SPOOL	4	216-1	SPRING SEAT	2	301	JOINT; M14	1
211	PLUG	4	216-2	SPRING SEAT	2	302	DISK	1
212-1	PUSH ROD	2	217	WASHER 2	4	312	ADJUSTING NUT; M14	1
212-2	PUSH ROD	2	221	SPRING	4	501	BELLOWS	1

CLICK HERE TO **DOWNLOAD** THE COMPLETE MANUAL

- Thank you very much for reading the preview of the manual.
- You can download the complete manual from: www.heydownloads.com by clicking the link below



- Please note: If there is no response to CLICKING the link, please download this PDF first and then click on it.

CLICK HERE TO **DOWNLOAD** THE COMPLETE MANUAL

[33. UPPER STRUCTURE]

33.2.3.5 Maintenance standard

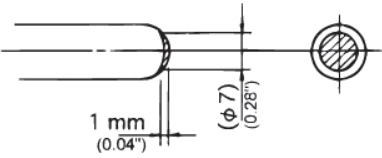
Maintenance item	Standard	Remarks
Amount of leakage	Replace with a complete set of pilot valve when the amount of leakage reaches more than 1000 cc/min (61 cu·in/min) or 2000 cc/min (122 cu·in/min) at the neutral position of the handle or during operation, respectively.	Condition : Primary pressure : 2.94MPa (427 psi) Oil viscosity : 23 mm ² /s
Spool	Replace with a complete set of pilot valve when an amount of wear at the sliding section is more than 10 μm (0.0004") in comparison with the non-sliding section.	The wear condition to the left is considered to correspond to the above amount of leakage.
Push rod	Replace when a wear amount of the tip is more than 1 mm (0.04"). 	
Unnecessary play in operation section	Replace when a play more than 2 mm(0.079") due to wear and so on is found on the disk (302) or joint section (301) of the operation section.	A play generated by loosening of tightening portion should be adjusted.
Action stability	Replace with a complete set of pilot valve when abnormal noise, hunting or primary pressure drop is generated during operation and the trouble cannot be remedied according to Section 33.2.3.6 TROUBLESHOOTING.	

Note

Replace seal such as O-ring with new ones after every disassembly.

[33. UPPER STRUCTURE]

(4) Disassembling of Hydraulic Motor

1. Loose the hexagon socket head cap bolts (124), and take out the hydraulic motor assembly from the reduction gear body.

Tools: Hexagon bar wrench: 6mm

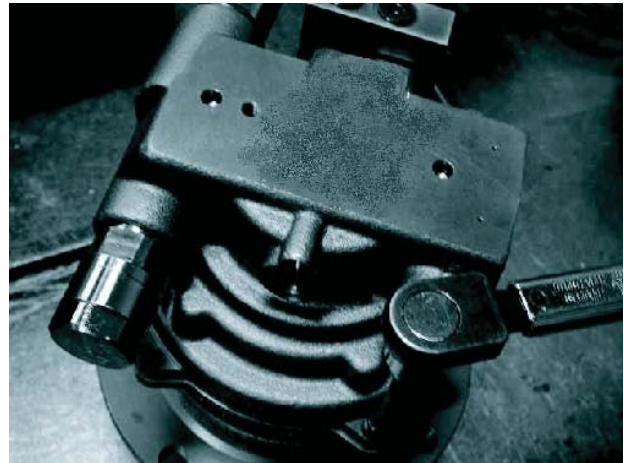

Note

When taking out the hydraulic motor assembly from the reduction gear body, the drain port should be open.

When it is difficult to take out, insert the minus driver into the binding face to the body and take out the burr completely.

2. Loose the hexagon socket head cap bolts (242), and take out the timer valve from the hydraulic motor assembly.

Tools: Hexagon bar wrench: 5mm

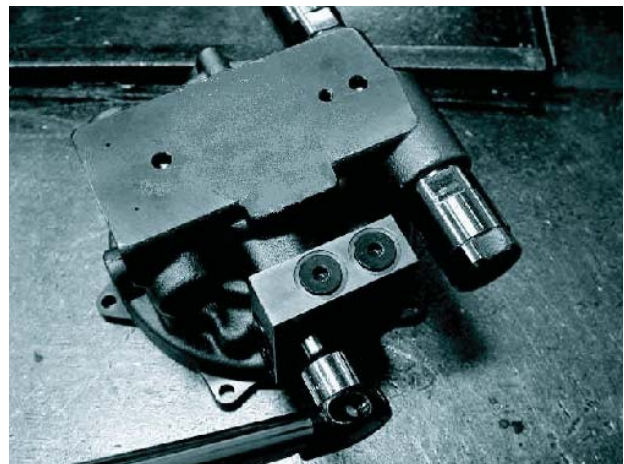

3. Take out the relief valve assembly.

Tools: Spanner: 36mm

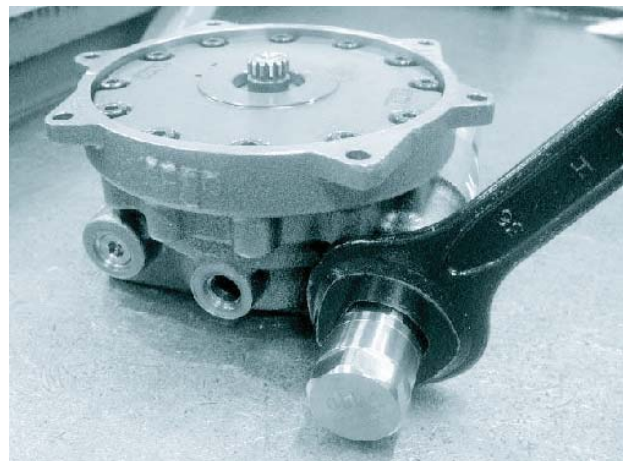

[33. UPPER STRUCTURE]

(6) Assembly of Hydraulic Motor Section

1. Press-fit the bearing (217) and spring pin (224) into the body H (201).



2. Insert the 2 check valves (246) (1pc/side), 2 springs (248) (1pc/side) and 2 plugs (247) (1pc/side) with O-ring (249) in that order into the body H (201).

Tools: Hexagon bar wrench: 8mm
Torque wrench

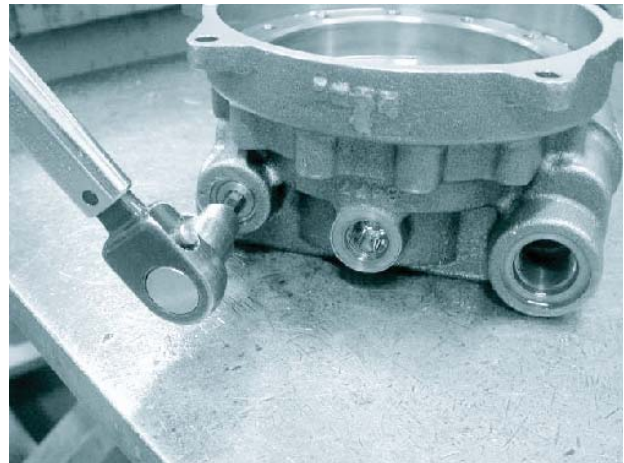
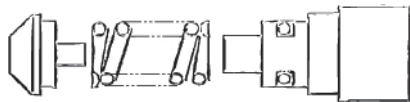

Note

Apply grease slightly to the O-ring and assemble to pay attention not biting the seals.
Plug tightening torque :58.8±2.9 N-m (43.4±2.14 lbf-ft)

[33. UPPER STRUCTURE]

5. Place the 4 B1 gears (106) (1pc/pin) and the 92 needles 1 (111) (23pcs/pin) in that order onto the 4 pins of the carrier 1 (102).



6. Place the thrust plate 1 (115) and the 4 snap rings (120) (1pc/pin) to make up a carrier 1 kit.

Tools: Snap ring plier: 22 dia. For shaft

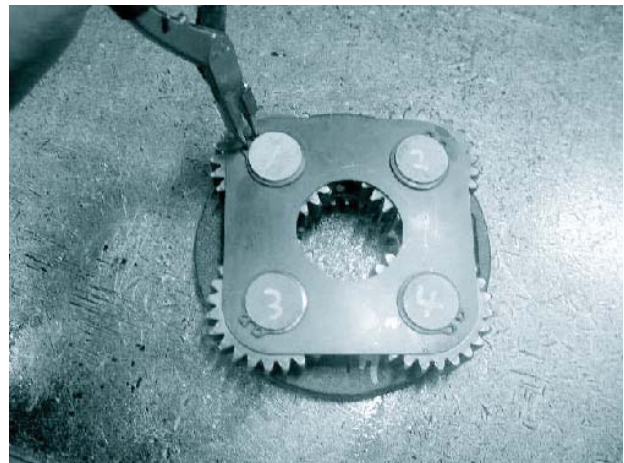

Note

Pay attention to the direction of the snap ring.

The edge side should be uppermost.

Pay attention not to open the snap ring too much.

The snap ring which was opened too much should lose tension and be replaced.

7. Place the 3 thrust washers 2 (118) (1pc/pin) and the 3 rings 2 (130) (1pc/pin) in that order onto the 3 pins of the carrier 2 (103).



[33. UPPER STRUCTURE]

33.2.6.3 MAINTENANCE STANDARDS

33.2.6.3.1 Check Procedures and Remedy

Check Interval	Place Checked	Check Procedure	Remedy
2000 Hr	Seals which prevent external leakage of hydraulic oil.	Check if oil is leaking out.	Replace the O-rings if there is leakage.
4000 hr	All seal parts.	—	Replace all the seal parts
Disassemble and check whether there is leakage or not	All sliding portion.	Check for abnormal wear, defects, corrosion, etc. due to seizing, foreign material being caught, etc.	Recondition in accordance with the service limit.
When disassembling due to trouble	All parts.	Check for abnormal wear, defects, corrosion, etc. due to seizing, foreign material being caught, etc.	Recondition in accordance with the service limit. Regarding the seal kit, replace

33.2.6.3.2 Parts Service Limit

(1) Body and Stem

Portion	Judgment Criteria	Remedy
Seal Parts and Sliding Portion	-Wearing of surface treated with induction hardening, and coming off of surface due to seizing, foreign material getting caught, etc.	Replace
Body and stem sliding portion other than seals.	-Abnormal wear or defects by 0.1 mm (0.004 in) deep or deeper due to seizing or foreign material getting caught, etc.	Replace
	-Defects less than 0.1 mm (0.004 in) deep.	Repair with an oil stone.
Portions which slide against the spacer.	-Wearing by 0.5 mm (0.020 in) or more, or abnormal wear.	Replace.
	-Wear less than 0.5 mm (0.020 in).	Repair so that is smooth.
	-Defects due to seizing or foreign material getting caught, etc. which are within the wear limit of 0.5 mm (0.020 in) and within repairable level.	Repair so that is smooth.

(2) Flange and Spacer

Portion	Judgment Criteria	Remedy
-Portions of flange which slide against the stem end. -Thrust ring	-Wearing by 0.5 mm (0.020 in) or more, or abnormal wear.	Replace
	-Wear less than 0.5 mm (0.020 in).	Repair so that is smooth.
	-Defects due to seizing or foreign material catching, etc., which are within the wear limit of 0.5 mm (0.020 in) and to within repairable level.	Repair so that is smooth.

[34. TRAVEL SYSTEM]

5. After press-fitting master pin (6), insert locking pin (8) and bend the tip of it.
6. After the installation is completed, adjust the tension of the crawler with the same method as the rubber crawler.

Tools: Socket: 17mm

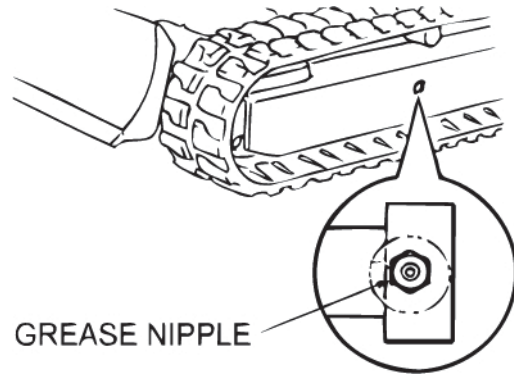

Extending track link (example of rubber crawler)

34.1.2.3 STRUCTURE

(1) Structure of Rubber Crawler

No.	NAME	Q'TY per machine
1	RUBBER CRAWLER ASSY	2
Parts No. of Rubber Crawler Assy		
PD61D00001P1		

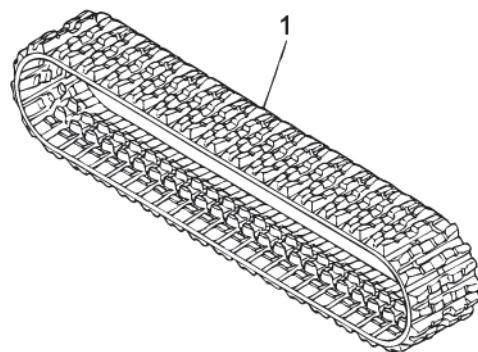

Rubber crawler assy

- This machine has the rubber crawlers installed as standard.

(2) Structure of Steel Crawler

(Q'TY for one side)		
No.	NAME	Q'TY
	Shoe assy	PX60D00012F1
1	• Shoe (Master)	1
1-2	•• Bushing	1
2	• Shoe (Track)	44
2-2	•• Bushing	44
3	•• Pin (Master)	1
4	•• Pin (Track)	44
5	•• Pin	1

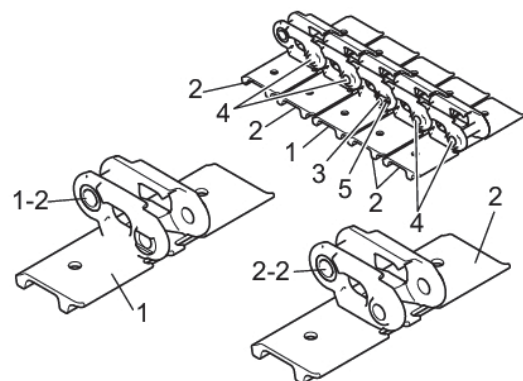

Structure of steel crawler

34.1.4.3.2 ASSEMBLY

- (1) Installation of O-ring (10) at one side of shaft

Install O-ring (10) on the groove of the shaft.

-Apply grease to O-ring.

-Be sure to replace the O-ring with a new one at reassembly.

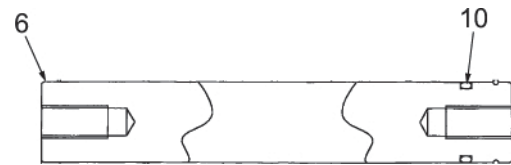

Installing O-ring (10) at one side of shaft

- (2) Press-fitting of bushing (7)

With bushing press-fitting jig (q) inserted into bushing (7), adjust a press to press the center of the internal diameter of roller (1) and bushing (7). And then press press-fitting jig with a press-fitting load of 3,600 kg (7,940 lbf) vertically. Press-fit bushing (7) on the opposite side.

-Apply the molybdenum disulfide grease to the press-fitted part of the bushing and press-fit it in ordinary temperature.

-Be sure to replace the bushing with a new one if you failed in press-fitting due to uneven press or other reason.

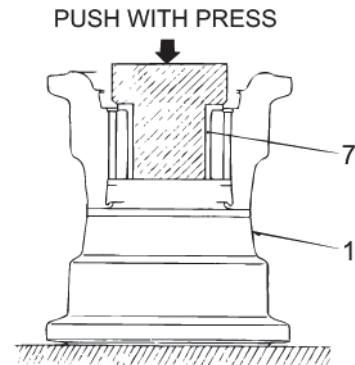

Press-fitting of bushing (7)

- (3) Press-fitting of collar (4)

Use a press to press collar (4) with floating seal (9) preassembled on the side of shaft (6) where O-ring (10) is installed, until the snap ring groove of shaft (6) aligns with the end face of collar (4).

-Be careful not to damage O-ring (10) when pressing collar (4) to shaft (6).

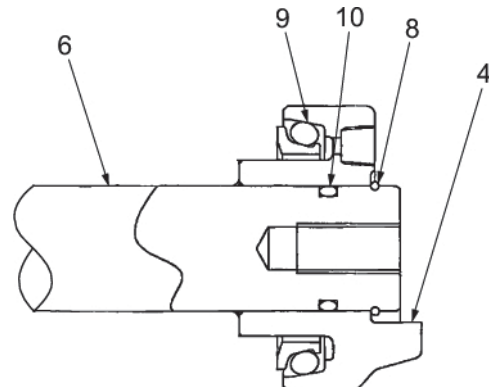

Press-fitting of collar (4)

34.1.6.3 DISASSEMBLY AND ASSEMBLY

(1) Disassembly of idler adjuster assy

1. Prepare spring set jig (V) as shown in the right figure or similar jig in advance when disassembling or assembling the idler adjuster assy.

Hydraulic jack capacity:

5 ton (11,000 lbf) or more

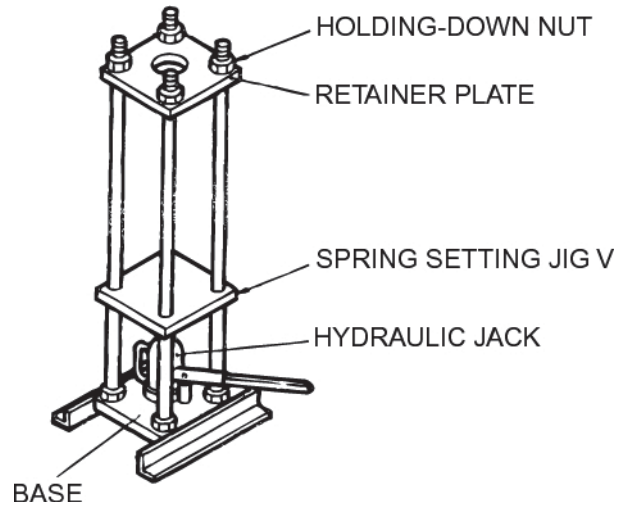

Dedicated jig for disassembly and assembly

CAUTION

Since the spring set force is very strong, the dedicated jig should be prepared to disassemble and assemble the assy.

2. Set a hydraulic jack between the jig base and the cradle.
3. Loosen the jig clamp nuts and pull out the clamp plate.
4. Pull out piston (1) from grease cylinder (2) of the idler adjuster assy.
5. Remove oil seal (7) and O-ring (8) from grease cylinder (2).
6. Place the idler adjuster assy without the parts removed in above-mentioned procedures on the jig cradle (V) with plate (4) at the top.

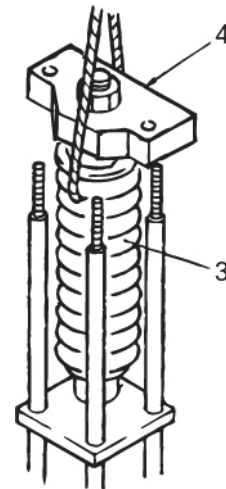

Suspending idler adjuster

7. Put the clamp plate over plate (4) and tighten the clamp nuts alternately to fix the idler adjuster assy while checking that the center hole aligns with the center of nut (5).

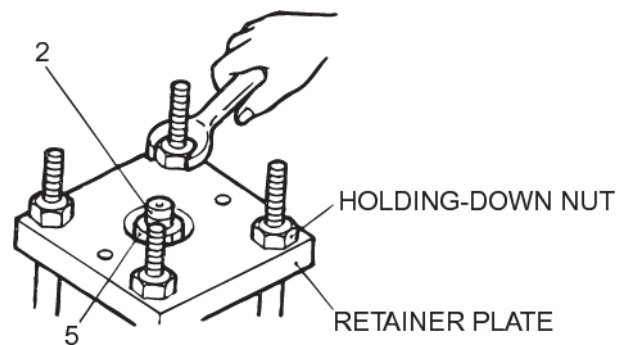

Setting clamp plate

CAUTION

The raceways should completely match by adjusting outer race (2). Use a push stick or pothook when inserting ball (3) and spacers (4) and (5). Never insert your fingers into the plug hole. It is very dangerous.

- (4) Push plug (6) into outer race (2) while checking the direction and position of taper pin (7) hole.
- (5) Hammer taper pin (7) and swage the head with a punch.
- (6) Check that grease nipple (10) works normally, rotation is smooth after injecting grease (SHELL Albania EP2), and there is no flaw on the lip of the seal.
Grease amount:
Approximately 90 g (0.20 lbs)

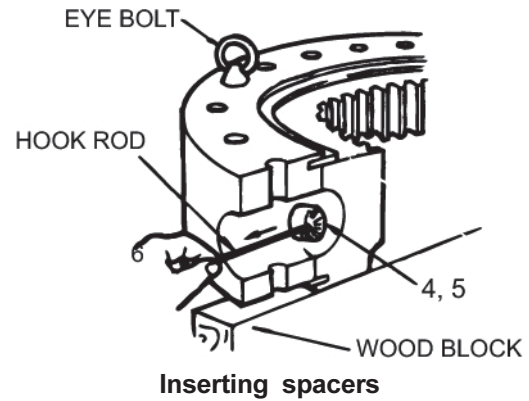

34.1.9.4 MAINTENANCE STANDARD

For maintenance standard for the wear of the swing bearing, see the swing bearing performance measurement described in Chapter 13.

[34. TRAVEL SYSTEM]

34.2.1.3.4 HYDRAULIC MOTOR SECTION (DISASSEMBLING)

- (1) Remove the seven hexagon socket head cap bolts.
Hexagon size: 8mm

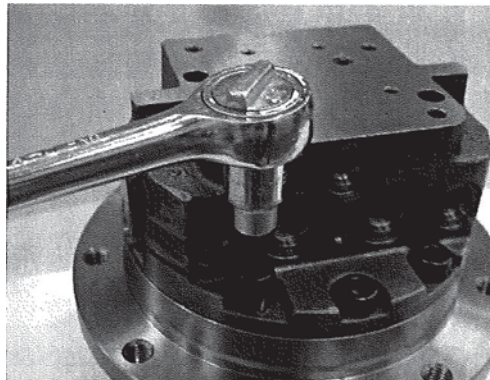

CAUTION

If you fix the motor with a vice, protect it with aluminum plates or equivalent.

- (2) Remove the body-1 from the body-2.

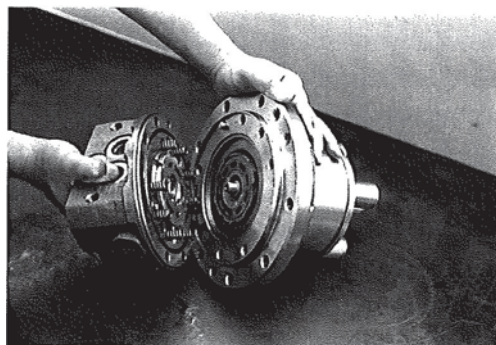

CAUTION

Pay attention not to come off and damage the valve plate.

- (3) Remove the valve plate and the six spring-B.



- (4) Remove the three O-rings from the body-1.

CAUTION

The bearing and spring pins are not able to disassemble, because they are press-fitted.

[34. TRAVEL SYSTEM]

(11) Place the two balls and the swash plate onto the body-2.

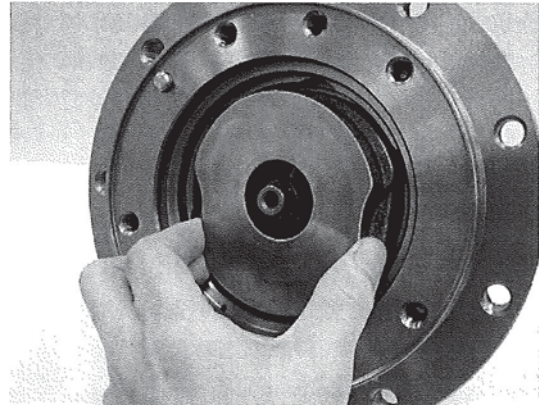
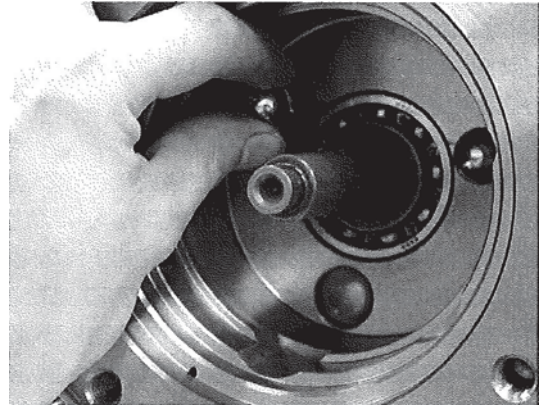

CAUTION

- Apply oil to the working face of the swash plate.
 - In case the swash plate drops out, apply grease to the back of it.
-

(12) Place the retainer, spring and retainer in that order into the cylinder barrel, and then secure them with the snap ring.

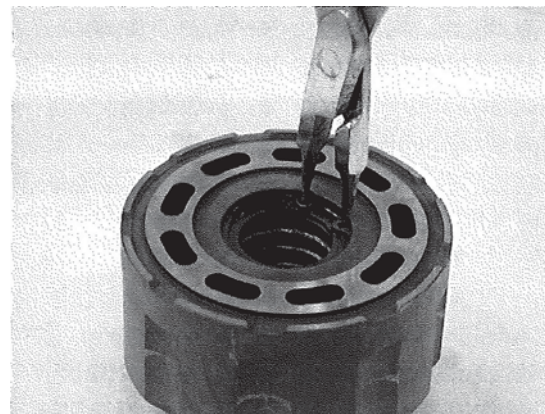
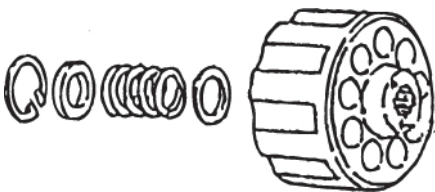

[34. TRAVEL SYSTEM]

- (9) Place the three thrust washers (1pc/1pin), three B2 gears (1pc/1pin), forty-eight needles (16pcs/1pin) and the three thrust washers (1pc/1pin), and secure it with three snap rings.

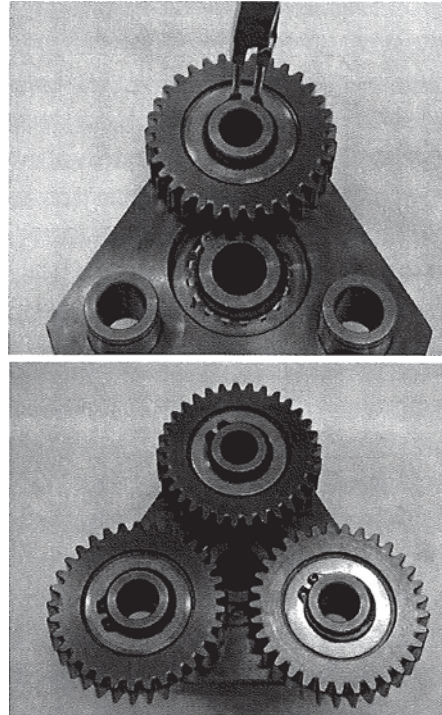

CAUTION

- Pay attention to the direction of the B2 gears. (See cross sectional drawing for the direction.)
 - Pay attention to the direction of the snap ring. The edge side should be uppermost.
 - Pay attention not to open the snap ring too much. A snap ring which loses tension should be replaced.
-

- (10) Place the carrier-2 assembly into the body.

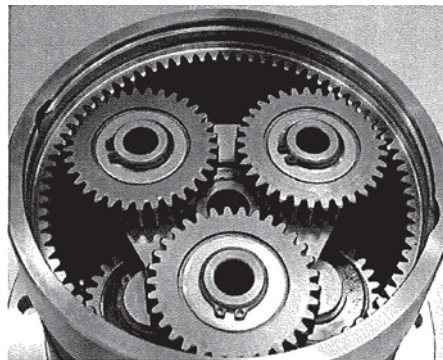

- (11) Join the S2 gear to the body.

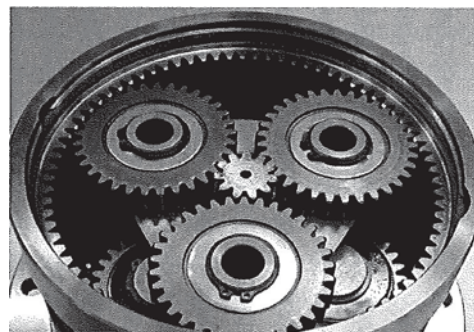

42.3.2 TRAVEL OPERATION

42.3.2.1 TRAVEL OPERATIONAL FAILURE

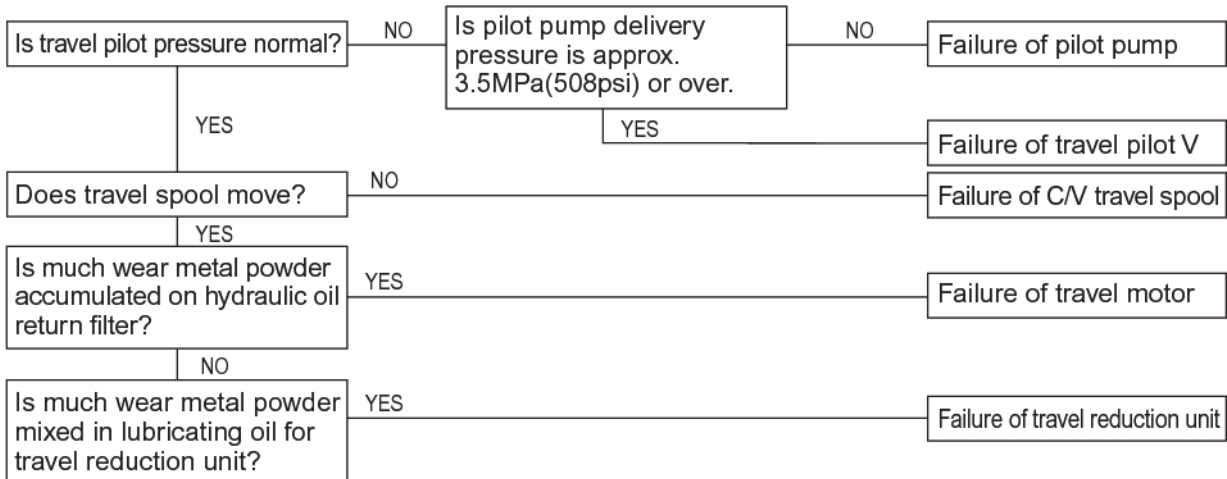

42.3.2.2 TRAVEL SPEED IS SLOW

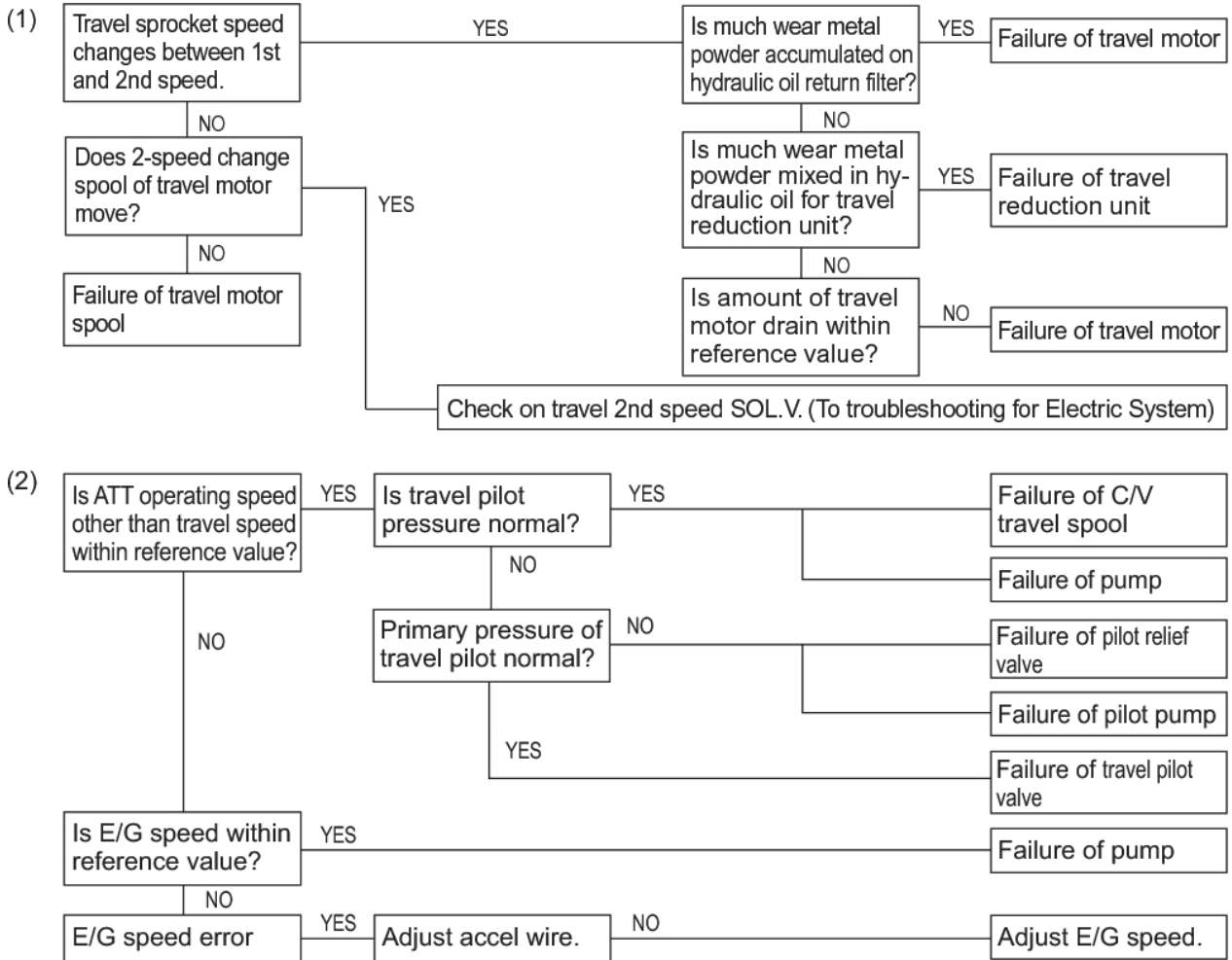

[43. TROUBLESHOOTING (ELECTRICAL SYSTEM)]

43.2.1.2 HORN DOES NOT SOUND.



43.2.1.3 WORKING LIGHT DOES NOT LIGHT UP.

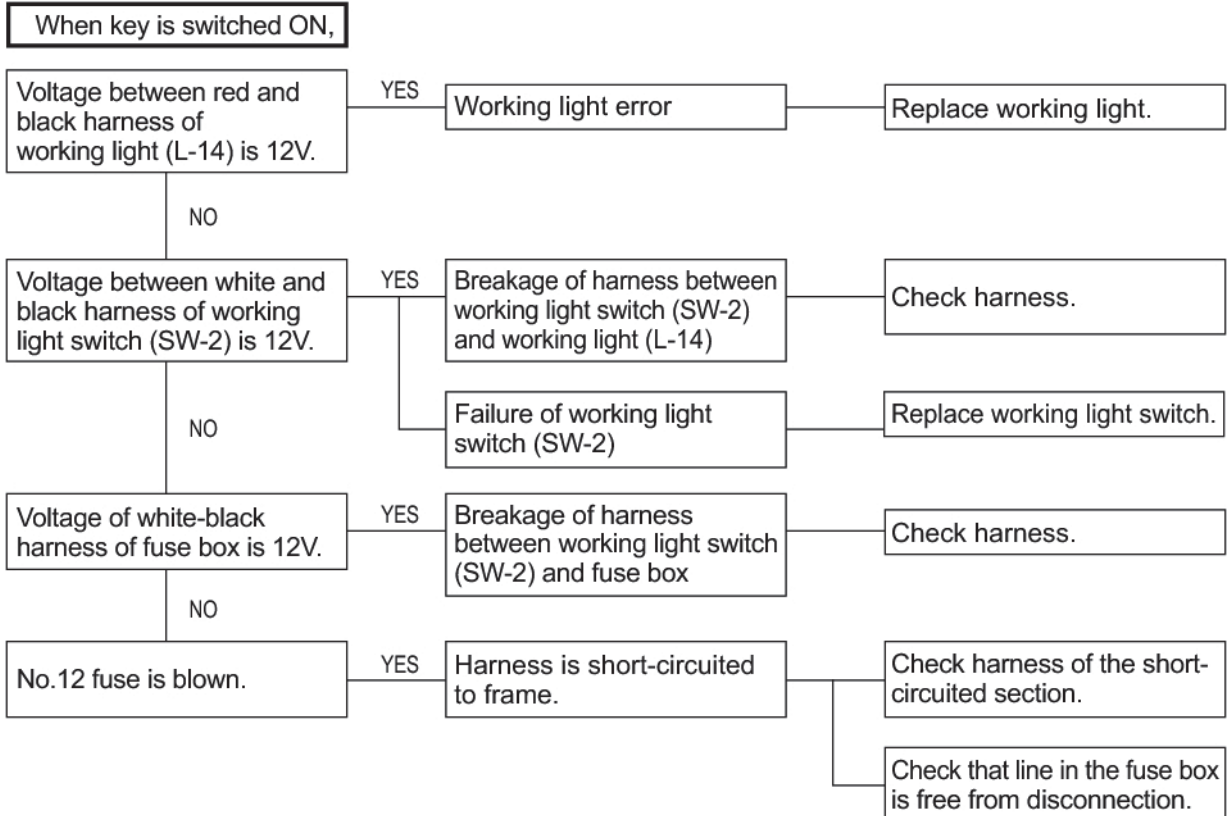

44.2 TROUBLESHOOTING

44.2.1 STARTING TROUBLE

44.2.1.1 STARTER DOES NOT ROTATE

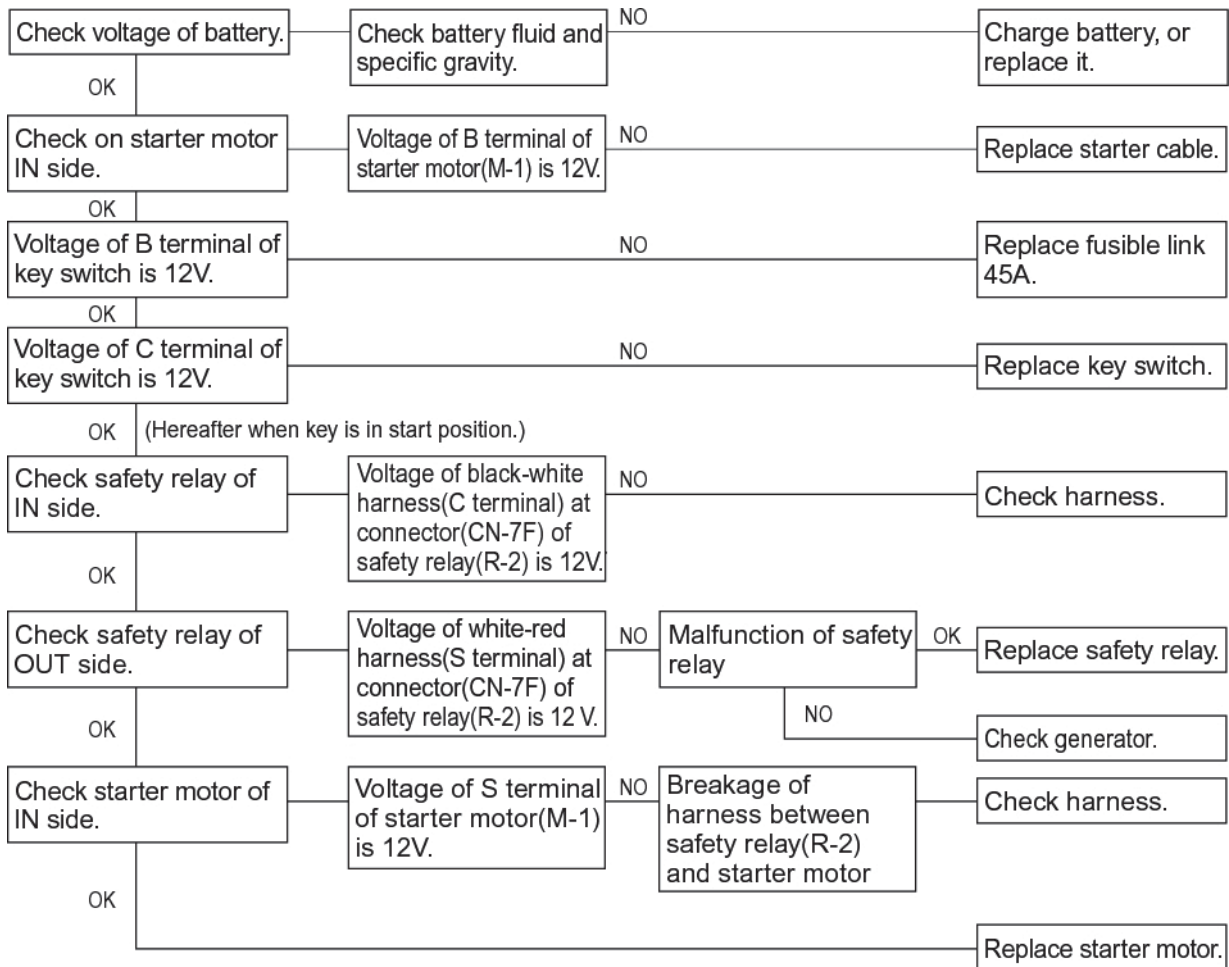

46.2 FAILURE CLASSIFICATION AND TROUBLESHOOTING PROCEDURES

Classify each failure into one of the following three types and refer to the troubleshooting corresponding to it.

No.	Classification of failure	Procedure of troubleshooting
A	When an error code of self-diagnosis is displayed on the gauge cluster	Carry out troubleshooting procedures in accordance with "TROUBLESHOOTING BY ERROR CODES" described later in this Chapter.
B	When the failure does not occur currently but a failure code of self-diagnosis remains in the failure history	If the failure is not reproducible, delete the data in the failure history to reproduce the error code and the cause and follow the troubleshooting by error code described later.
C	When an error code of self-diagnosis is not displayed and is not found in the failure history	-Carry out troubleshooting procedures in accordance with the troubleshooting in other Chapters.

[46. TROUBLE SHOOTING (OPT.) (BY ERROR CODES)]

Error code	H034		
Description of failure	Arm angle potentiometer, power short		
Judged by	Input voltage from the arm angle potentiometer is less than 0.1 V.		
Symptom	The rating, load and radius of the high reach crane are displayed as abnormal values.		
Control at failure	Controlled normally.		
Return in normal condition	Returned automatically when in normal condition.		
Confirmation screen for service diagnosis	Screen No.	4	Arm
	Screen No.		
	Screen No.		
To be inspected		Inspection and action	
1	-Arm angle potentiometer SE-11	Measure the resistance between the terminals of the arm angle potentiometer. 4.0 - 6.0kΩ Turn potentiometer to measure the resistance between the signal and GND. 0 - total resistance (4.0 - 6.0) kΩ	
2	-Wiring between arm angle potentiometer and controller CN-427F CN-500F	Inspect and repair according to wiring check procedure.	
3	-Mechatronic controller	Replace the controller and check if the failure goes away.	

This Page Intentionally Left Blank

Limited Emission Control System Warranty - USA Only - Continued**Exclusions:**

Failures other than those arising from defects in material and / or workmanship are not covered by this warranty. The warranty does not extend to the following: malfunctions caused by abuse, misuse, improper adjustment, modification, alteration, tampering, disconnection, improper or inadequate maintenance or use of non-recommended fuels and lubricating oils; accident-caused damage, and replacement of expendable items made in connection with scheduled maintenance. Yanmar disclaims any responsibility for incidental or consequential damages such as loss of time, inconvenience, loss of use of equipment / engine or commercial loss.

Owner's Warranty Responsibilities:

As the engine owner, you are responsible for the performance of the required maintenance listed in your owner's manual. Yanmar recommends that you retain all documentation, including receipts, covering maintenance on your non-road compression-ignition engine, but Yanmar cannot deny warranty solely for the lack of receipts, or for your failure to ensure the performance of all scheduled maintenance.

Yanmar may deny your warranty coverage of your non-road compression-ignition engine if a part has failed due to abuse, neglect, improper maintenance or unapproved modifications.

Your engine is designed to operate on diesel fuel only. Use of any other fuel may result in your engine no longer operating in compliance with applicable emissions requirements.

You are responsible for initiating the warranty process. You must present your engine to a Yanmar dealer as soon as a problem exists. The warranty repairs should be completed by the dealer as expeditiously as possible. If you have any questions regarding your warranty rights and responsibilities, or would like information on the nearest Yanmar dealer or authorized service center, you should contact Yanmar America Corporation at 1-800-872-2867.

NOTICE

Make sure the engine is installed on a level surface. If a continuously running engine is installed at an angle greater than (IDI = 25°, DI = 30°) in any direction or if an engine runs for short periods of time (less than three minutes) at an angle greater than (IDI = 30°, DI = 35°) in any direction, engine oil may enter the combustion chamber causing excessive engine speed and white exhaust smoke. This may cause serious engine damage.

NOTICE

Observe the following environmental operating conditions to maintain engine performance and avoid premature engine wear:

- Avoid operating in extremely dusty conditions.
- Avoid operating in the presence of chemical gases or fumes.
- Avoid operating in a corrosive atmosphere such as salt water spray.
- NEVER install the engine in a floodplain unless proper precautions are taken to avoid being subject to a flood.
- NEVER expose the engine to the rain.

NOTICE

Observe the following environmental operating conditions to maintain engine performance and avoid premature engine wear:

- The standard range of ambient temperatures for the normal operation of Yanmar engines is from +5°F (-15°C) to +113°F (+45°C).
- If the ambient temperature exceeds +113°F (+45°C) the engine may overheat and cause the engine oil to break down.
- If the ambient temperature is below +5°F (-15°C) the engine will be hard to start and the engine oil may not flow easily.
- Contact your authorized Yanmar industrial engine dealer or distributor if the engine will be operated outside of this standard temperature range.

NOTICE

The illustrations and descriptions of optional equipment in this manual, such as the operator's console, are for a typical engine installation. Refer to the documentation supplied by the optional equipment manufacturer for specific operation and maintenance instructions.

NOTICE

If any indicator illuminates during engine operation, stop the engine immediately. Determine the cause and repair the problem before you continue to operate the engine.

GENERAL SERVICE INFORMATION

Specifications	4-24
Description of Model Number.....	4-24
Engine Speed Specifications.....	4-24
Engine General Specifications	4-25
Principal Engine Specifications	4-26
3TNV82A (~ EPA Tier2)	4-26
3TNV84 (~ EPA Tier2)	4-27
3TNV84T (~ EPA Tier2)	4-28
3TNV88 (~ EPA Tier2)	4-29
4TNV84 (~ EPA Tier2)	4-30
4TNV84T (~ EPA Tier2)	4-31
4TNV88 (~ EPA Tier2)	4-32
4TNV94L (~ EPA Tier2)	4-33
4TNV98 (~ EPA Tier2)	4-34
4TNV98T (~ EPA Tier2)	4-35
4TNV106 (~ EPA Tier2)	4-36
4TNV106T (~ EPA Tier2)	4-37
3TNV82A-B (complies with EPA Interim Tier4).....	4-38
3TNV84T-Z (complies with EPA Interim Tier4)	4-39
3TNV84T-B (complies with EPA Interim Tier4)	4-40
3TNV88-Z (complies with EPA Interim Tier4)	4-41
3TNV88-U (complies with EPA Interim Tier4)	4-42
3TNV88-B (complies with EPA Interim Tier4)	4-43
4TNV84T-B / 4TNV84T-Z (complies with EPA Interim Tier4) ..	4-44
4TNV88-Z (complies with EPA Interim Tier4)	4-45
4TNV88-U (complies with EPA Interim Tier4)	4-46
4TNV88-B (complies with EPA Interim Tier4)	4-47
4TNV98-E (complies with EPA Interim Tier4)	4-48
4TNV98-Z (complies with EPA Interim Tier4)	4-49
4TNV98T-Z (complies with EPA Interim Tier4)	4-50
Engine Service Standards.....	4-51
Tightening Torques for Standard Bolts and Nuts	4-52
Abbreviations and Symbols.....	4-54
Abbreviations.....	4-54
Symbols.....	4-54
Unit Conversions	4-55
Unit Prefixes	4-55
Units of Length	4-55
Units of Volume	4-55
Units of Mass.....	4-55
Units of Force	4-55
Units of Torque.....	4-55
Units of Pressure.....	4-55
Units of Power	4-55
Units of Temperature.....	4-55

DIESEL FUEL

Diesel Fuel Specifications

Diesel fuel should comply with the following specifications. The table lists several worldwide specifications for diesel fuels.

Diesel Fuel Specification	Location
ASTM D975 No. 1D S15 No. 2D S15	USA
EN590:96	European Union
ISO 8217 DMX	International
BS 2869-A1 or A2	United Kingdom
JIS K2204 Grade No. 2	Japan
KSM-2610	Korea
GB252	China

Additional Technical Fuel Requirements

- The fuel cetane number should be equal to 45 or higher.
- The sulfur content must not exceed 0.5% by volume. Less than 0.05% is preferred.
For electronically controlled engines 4TNV84T-Z, 4TNV98-Z, 4TNV98-E, and 4TNV98T-Z (EGR system equipped engines), it is mandatory to use fuel that does not contain 0.1% or more sulfur content.
In general, using a high sulfur fuel may possible result in corrosion inside the cylinder. Especially in U.S.A. and Canada, Ultra Low Sulfur fuel must be used.
- Bio-Diesel fuels. *See Bio-Diesel Fuels on page 4-13.*
- NEVER mix kerosene, used engine oil, or residual fuels with the diesel fuel.
- The water and sediment in the fuel should not exceed 0.05% by volume.
- Keep the fuel tank and fuel-handling equipment clean at all times.
- Poor quality fuel can reduce engine performance and / or cause engine damage.
- Fuel additives are not recommended. Some fuel additives may cause poor engine performance. Consult your Yanmar representative for more information.
- The ash content must not exceed 0.01% by volume.
- The carbon residue content must not exceed 0.35% by volume. Less than 0.1% is preferred.
- The total aromatics content should not exceed 35% by volume. Less than 30% is preferred.
- The PAH (polycyclic aromatic hydrocarbons) content should be below 10% by volume.
- The metal content of Na, Mg, Si, and Al should be equal to or lower than 1 mass ppm. (Test analysis method JPI-5S-44-95)
- Lubricity: The wear mark of WS1.4 should be Max. 0.018 in (460 μm) at HFRR test.

Engine Coolant Specifications

Use a Long Life Coolant (LLC) or an Extended Life Coolant (ELC) that meets or exceeds the following guidelines and specifications:

Additional Technical Coolant Specifications:

- ASTM D6210, D4985 (US)
- JIS K-2234 (Japan)
- SAE J814C, J1941, J1034 or J2036 (International)

Alternative Engine Coolant

If an Extended or Long Life Coolant is not available, alternatively, you may use an ethylene glycol or propylene glycol based conventional coolant (green).

Notes:

- ALWAYS use a mix of coolant and water. NEVER use water only.
- Mix the coolant and water per the mixing instructions on the coolant container.
- Water quality is important to coolant performance. Yanmar recommends that soft, distilled, or demineralized water be used to mix with coolants.
- NEVER mix extended or long life coolants and conventional (green) coolants.
- NEVER mix different types and / or colors of extended life coolants.
- Replace the coolant every 1000 engine hours or once a year.

Filling Radiator with Engine Coolant

Fill the radiator and reserve tank as follows. This procedure is for filling the radiator for the first time or refilling it after it is flushed. Note that a typical radiator is illustrated (**Figure 4-7**).

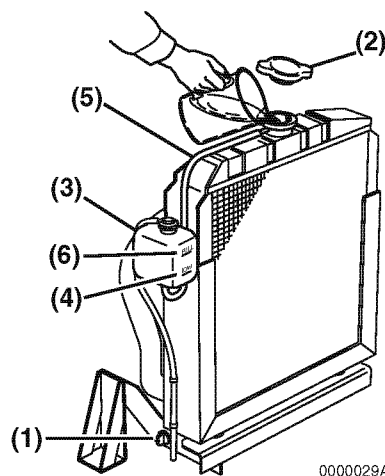

Figure 4-7

1. Check to be sure the radiator drain plug is installed and tightened or the drain cock (**Figure 4-7, (1)**) is closed. Also make sure the coolant drain plug (**Figure 4-8, (1)**) in the cylinder block is closed or the oil coolant hoses (**Figure 4-9, (1)**) are installed at the oil cooler.

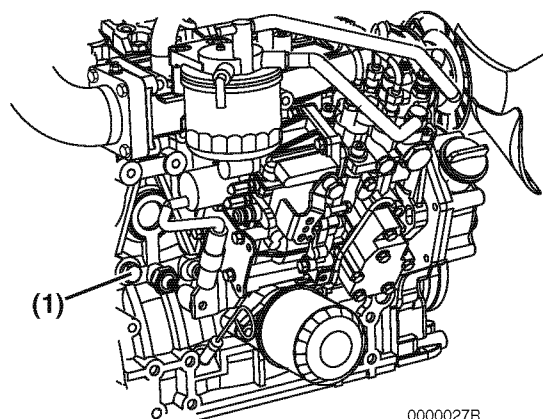

Figure 4-8

4TNV88 (~ EPA Tier2)

Engine Model	4TNV88								
Version	CL			VM					
Type	Vertical In-line Diesel Engine								
Combustion System	Direct Injection								
Aspiration	Natural								
No. of Cylinders	4								
Bore × Stroke	88 × 90mm								
Displacement	2.190L								
Continuous Rated Output	min ⁻¹	1500	1800						
	kW	16.4	19.6						
	PS	22.3	26.7						
Max. Rated Output (Net)	min ⁻¹	1500	1800	2000	2200	2400	2600	2800	3000
	kW	18.0	21.6	24.1	26.5	28.8	31.3	33.7	35.4
	PS	24.5	29.4	32.7	36.0	39.2	42.5	45.8	48.1
High Idling	min ⁻¹	1600 ± 25	1895 ± 25	2180 ± 25	2400 ± 25	2590 ± 25	2810 ± 25	2995 ± 25	3210 ± 25
Engine Weight (Dry) *with Flywheel Housing	183 kg			170 kg					
PTO Position	Flywheel End								
Direction of Rotation	Counterclockwise Viewed From Flywheel End								
Cooling System	Liquid-Cooled with Radiator								
Lubricating System	Forced Lubrication with Trochoid Pump								
Normal Oil Pressure at Rated Engine Speed	0.34 - 0.49 MPa			0.39 - 0.54 MPa					
Normal Oil Pressure at Low Idle Speed	0.06 MPa								
Starting System	Electric Starting (Starter Motor: DC12V (1.4 kW)) ***								
	Alternator: DC12V, 40A***								
	Recommended Battery Capacity: 12V, 64 Ah*** (5h rating) ***								
Dimensions (L × W × H)*	683 × 498.5 × 618 mm			658 × 498.5 × 618 mm					
Engine Oil Pan Capacity**	7.4 / 4.0 L (Dipstick Upper Limit / Lower Limit)								
Engine Coolant Capacity	2.7L Engine Only								
Standard Cooling Fan	370mm O.D., 6 Blade Pusher-Type ***								
Crank V-pulley dia./ Fan V-pulley dia.	φ120/ φ90mm ***			φ110/ φ110mm ***					
Top Clearance	0.73 ± 0.06mm								

* Engine specifications without radiator.

** Engine oil capacity for a "Deep Standard" oil pan. Refer to the operation manual provided by the driven machine manufacturer for the actual engine oil capacity of your machine.

*** May vary depending on application.

3TNV88-U (complies with EPA Interim Tier4)

Engine Model		3TNV88-U											
Version		CL	VM										
Type		Vertical, 4-cycle water-cooled diesel engine											
Combustion System		Direct Injection											
Aspiration		Natural aspiration											
No. of Cylinders		3											
Bore × Stroke		φ88 × 90mm											
Displacement		1.642L											
Continuous Rated Output	min ⁻¹												
	kW												
	PS												
Max. Rated Output (Net)	min ⁻¹					2200	2300	2400	2500	2600	2700	2800	3000
	kW					18.1	18.9	19.7	20.5	21.3	22.2	23.0	24.6
	PS					24.6	25.7	26.8	27.9	29.0	30.2	31.3	33.5
High Idling	min ⁻¹					2400 ±25	2510 ±25	2590 ±25	2700 ±25	2810 ±25	2920 ±25	2995 ±25	3210 ±25
Engine Weight (dry) *with Flywheel Housing		155kg											
PTO Position		Flywheel End											
Direction of Rotation		Counterclockwise Viewed From Flywheel End											
Governor		Mechanical governor (All-speed governor)											
Cooling System		Liquid-Cooled with Radiator											
Lubricating System		Forced Lubrication with Trochoid Pump											
Normal Oil Pressure	Rated Engine Speed	0.34-0.49 (3.5-5.0) MPa										0.39-0.54 (4.0-5.5) MPa	
	Low Idle Speed	≥ 0.06 (≥ 0.6) MPa											
Starting System		Electric Starting (Starter Motor: DC12V (1.7kW)) ***											
Charging system		Alternator (DC12V/40A) ***											
Recommended Battery Capacity		12V-55Ah*** (5h rating)											
Starting aid device		Super-quick Heating Glow plug											
Dimensions (L × W × H)*		568 × 514 × 622mm											
Engine Oil Pan Capacity**		6.7L/3.9L (Dipstick Upper Limit / Lower Limit)											
Engine Coolant Capacity		2.0L Engine Only											
Standard Cooling Fan		Resin F type pusher fan - φ335(NF) × 6											
Crank V-pulley dia./ Fan V-pulley dia.		φ110/φ110mm											
Top Clearance		0.73 ± 0.06mm											

* Engine specifications without radiator.

** Engine oil capacity for a "Deep Standard" oil pan. Refer to the operation manual provided by the driven machine manufacturer for the actual engine oil capacity of your machine.

*** May vary depending on application.

TIGHTENING TORQUES FOR STANDARD BOLTS AND NUTS

Use the correct amount of torque when you tighten the fasteners on the machine. Applying excessive torque may damage the fastener or component and not enough torque may cause a leak or component failure.

NOTICE

The tightening torque in the Standard Torque Chart (see *General Service Information* section) should be applied only to the bolts with a "7" head. (JIS strength classification: 7T)

- Apply 60% torque to bolts that are not listed.
- Apply 80% torque when tightened to aluminum alloy.







Item	Nominal Thread Diameter x Pitch	Tightening Torque	Remarks
Hexagon Bolt (7T) and Nut	M6 x 1.0 mm	7 - 9 ft-lb (87 -104 in.-lb, 9.8 -11.8 N-m, 1.0 -1.2 kgf-m)	Use 80% of the value at left when the tightening part is aluminum. Use 60% of the value at left for 4T bolts and lock nuts.
	M8 x 1.25 mm	17 - 21 ft-lb (200 - 251 in.-lb, 22.6 - 28.4 N-m, 2.3 - 2.9 kgf-m)	
	M10 x 1.5 mm	33 - 40 ft-lb (44.1 - 53.9 N-m, 4.5 - 5.5 kgf-m)	
	M12 x 1.75 mm	58 - 72 ft-lb (78.4 - 98.0 N-m, 8.0 - 10 kgf-m)	
	M14 x 1.5 mm	94 - 108 ft-lb (127.5 - 147.1 N-m, 13 - 15 kgf-m)	
	M16 x 1.5 mm	159 - 174 ft-lb (215.7- 235.4 N-m, 22 - 24 kgf-m)	
PT PLug	1/8	7 ft-lb (87 in.-lb, 9.8 N-m, 1.0 kgf-m)	
	1/4	14 ft-lb (173 in.-lb, 19.6 N-m, 2.0 kgf-m)	
	3/8	22 ft-lb (29.4 N-m, 3.0 kgf-m)	
	1/2	43 ft-lb (58.8 N-m, 6.0 kgf-m)	

PERIODIC MAINTENANCE

Periodic Maintenance Schedule

○: Check ◇: Replace ●: Contact your authorized Yanmar industrial engine dealer or distributor

System	Check Item	Daily	Periodic Maintenance Interval						
			Every 50 hours	Every 250 hours	Every 500 hours	Every 1000 hours	Every 1500 hours	Every 2000 hours	Every 3000 hours
Cooling System	Check and Refill Engine Coolant	○							
	Check and Clean Radiator Fins		○						
	Check and Adjust Cooling Fan V-belt		○ 1st time	○ 2nd and after					
	Drain, Flush and Refill Cooling System With New Coolant					◇ or every 1 year which-ever comes first			
Cylinder Head	Adjust Intake / Exhaust Valve Clearance					●			
	Lap Intake / Exhaust Valve Seats (if required)							●	
Electrical Equipment	Check Indicators	○							
	Check Battery		○						
Engine Oil	Check Engine Oil Level	○							
	Drain and Fill Engine Oil		◇ 1st time	◇ 2nd and after					
	Replace Engine Oil Filter								
Engine Speed Control	Check and Adjust Governor Lever and Engine Speed Control	○		○					
Emission Control Warranty	Inspect, Clean And Test Fuel Injectors, if necessary						●		
	 Inspect Turbocharger (Blower Wash as Necessary)								●
	 Inspect, Clean and Test EGR Valve								●
	 Clean EGR Lead Valve								●
	 Clean EGR Cooler (Clean to Blow Water/Air Passages)						●		
	Inspect Crankcase Breather System						●		
Fuel	Check and Refill Fuel Tank Level	○							
	Drain Fuel Tank			○					
	Drain Fuel Filter / Water Separator	○							
	Check Fuel Filter / Water Separator	○							
	Clean Fuel Filter / Water Separator				○				
	Replace Fuel Filter				◇				
Hoses	Replace Fuel System and Cooling System Hoses							◇ or every 2 yrs.	

5. Reinstall the fuel cap.
6. Check for leaks.

Replace Engine Oil and Engine Oil Filter

NOTICE

- Only use the engine oil specified. Other engine oils may affect warranty coverage, cause internal engine components to seize and / or shorten engine life.
- Prevent dirt and debris from contaminating the engine oil. Carefully clean the oil cap / dipstick and the surrounding area before you remove the cap.
- NEVER mix different types of engine oil. This may adversely affect the lubricating properties of the engine oil.
- NEVER overfill. Overfilling may result in white exhaust smoke, engine overspeed or internal damage.

NOTICE

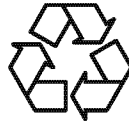

- ALWAYS be environmentally responsible.

- Follow the guidelines of the EPA or other governmental agencies for the proper disposal of hazardous materials such as engine oil, diesel fuel and engine coolant. Consult the local authorities or reclamation facility.
- NEVER dispose of hazardous materials irresponsibly by dumping them into a sewer, on the ground, or into ground water or waterways.
- Failure to follow these procedures may seriously harm the environment.

Change the engine oil every 250 hours of operation after the initial change at 50 hours. Replace the engine oil filter at the same time. *See Replace Engine Oil and Engine Oil Filter on page 5-8.*

Clean EGR Cooler
4TNV84T-Z, 4TNV98T-Z

The EGR cooler is apt to be contaminated with rust and scale that deteriorate the cooling performance. Carbon accumulation in the exhaust gas passage of the cooler hinders circulation of exhaust gas, resulting in deterioration in exhaust gas cleanup performance.

To prevent such a problem, clean the cooler at least every 1500 hours.

Consult your local Yanmar dealer for this service.

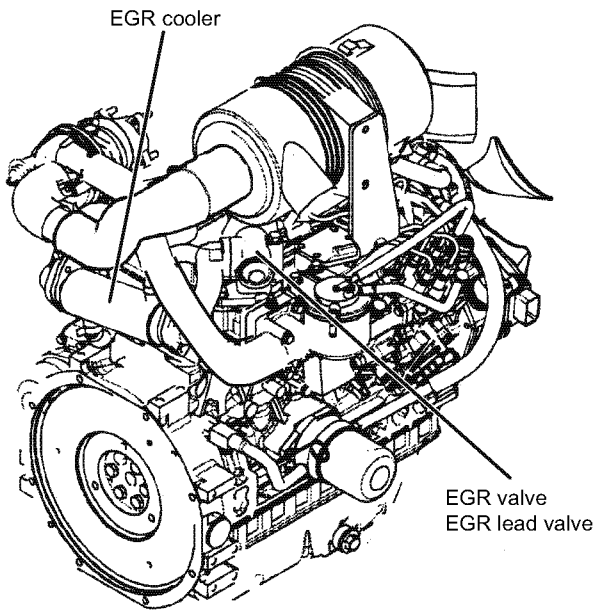

Figure 5-19

Inspect Crankcase Breather System

Proper operation of the crankcase breather system is required to maintain the emission requirements of the engine. The EPA / ARB requires that the crankcase breather system is inspected every 1500 hours.

There are three different crankcase breather systems used on the TNV engines. Only the non-turbo TNV engines crankcase breather system requires periodic maintenance.

The non-turbo TNV engines use a crankcase breather system that has a spring-backed diaphragm (**Figure 5-20, (1)**) in the valve cover (**Figure 5-20, (2)**). When the crankcase pressure reaches a predetermined value, the diaphragm opens a passage that allows crankcase fumes to be routed to the intake manifold.

To inspect the diaphragm and spring (**Figure 5-20, (3)**):

1. Remove the bolts retaining the diaphragm cover (**Figure 5-20, (4)**).

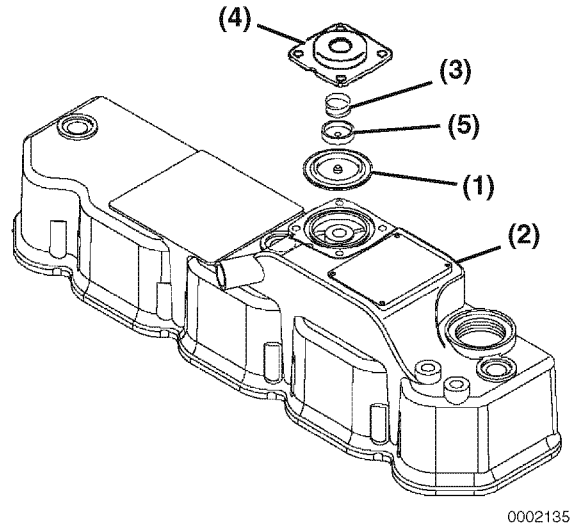

Figure 5-20

2. Remove the diaphragm cover, spring, diaphragm plate (**Figure 5-20, (5)**) and diaphragm.
3. Inspect the diaphragm for tears. Inspect the spring for distortion. Replace components if necessary.
4. Reinstall the diaphragm, diaphragm plate, spring and diaphragm cover. Tighten the diaphragm bolts to specified torque.

Valve Spring

Inspection Item	Model	Standard	Limit	Reference Page
Free Length	3TNV82A (2-Valve Head)	1.7480 in. (44.4 mm)	1.7283 in. (43.9 mm)	<i>See Inspection of Valve Springs on page 6-42 and 6-58.</i>
	4TNV84, 3TNV84, 3TNV84T, 4TNV88 (2-Valve Head)	1.6535 in. (42.0 mm)	1.6339 in. (41.5 mm)	
	4TNV84T (4-Valve Head)	1.4724 in. (37.4 mm)	1.4528 in. (36.9 mm)	
	4TNV94L, 4TNV98, 4TNV98T (4-Valve Head)	1.5630 in. (39.7 mm)	1.5433 in. (39.2 mm)	
	4TNV106, 4TNV106T (4-Valve Head)	1.9921 in. (50.6 mm)	1.9724 in. (50.1 mm)	
Squareness	3TNV82A (2-Valve Head)	-	0.0551 in. (1.4 mm)	
	4TNV84, 3TNV84, 3TNV84T, 4TNV88 (2-Valve Head)	-	0.0551 in. (1.4 mm)	
	4TNV84T (4-Valve Head)	-	0.0551 in. (1.3 mm)	
	4TNV94L, 4TNV98, 4TNV98T (4-Valve Head)	-	0.0551 in. (1.4 mm)	
	4TNV106, 4TNV106T (4-Valve Head)	-	0.0551 in. (1.5 mm)	

(Piston Ring Cont.)

Model	Inspection Item		Standard	Limit	Reference Page
4TNV94L, 4TNV98, 4TNV98T	Top Ring	Ring Groove Width	0.0803 - 0.0811 in. (2.040 - 2.060 mm)	-	<i>See Inspection of Pistons, Piston Rings and Wrist Pin on page 6-81.</i>
		Ring Width	0.0764 - 0.0772 in. (1.940 - 1.960 mm)	0.0756 in. (1.920 mm)	
		Side Clearance	0.0031 - 0.0047 in. (0.080 - 0.120 mm)	-	
		End Gap	0.0098 - 0.0177 in. (0.250 - 0.450 mm)	0.0213 in. (0.540 mm)	
	Second Ring	Ring Groove Width	0.0819 - 0.0825 in. (2.080 - 2.095 mm)	0.0864 in. (2.195 mm)	
		Ring Width	0.0776 - 0.0783 in. (1.970 - 1.990 mm)	0.0768 in. (1.950 mm)	
		Side Clearance	0.0035 - 0.0049 in. (0.090 - 0.125 mm)	0.0096 in. (0.245 mm)	
		End Gap	0.0177 - 0.0256 in. (0.450 - 0.650 mm)	0.0287 in. (0.730 mm)	
	Oil Ring	Ring Groove Width	0.1187 - 0.1193 in. (3.015 - 3.030 mm)	0.1232 in. (3.130 mm)	
		Ring Width	0.1169 - 0.1177 in. (2.970 - 2.990 mm)	0.1161 in. (2.950 mm)	
		Side Clearance	0.0010 - 0.0024 in. (0.025 - 0.060 mm)	0.0071 in. (0.180 mm)	
		End Gap	0.0098 - 0.0177 in. (0.250 - 0.450 mm)	0.0217 in. (0.550 mm)	

(Special Service Tools Cont.)

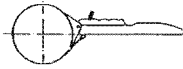
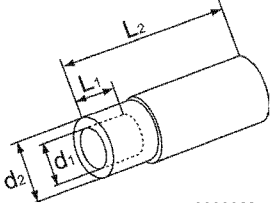
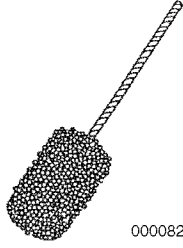
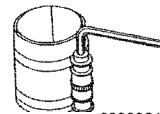
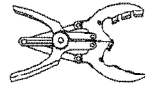
No.	Tool Name	Applicable Model and Tool Size					Illustration	
7	Filter Wrench (For Removal / Installation of Engine Oil Filter)	Available Locally					 <p style="text-align: right;">0000821</p>	
8	Camshaft Bushing Tool (For Extracting Camshaft Bushing)	Model	L1	L2	d1	d2	 <p style="text-align: right;">0000822</p>	
		3TNV82A, 3TNV84, 3TNV84T, 3TNV88, 4TNV84, 4TNV84T, 4TNV88	0.709 in. (18 mm)	2.756 in. (70 mm)	1.772 in. (45 mm)	1.890 in. (48 mm)		
		4TNV94L, 4TNV98, 4TNV98T	0.709 in. (18 mm)	2.756 in. (70 mm)	1.968 in. (50 mm)	2.087 in. (53 mm)		
		4TNV106, 4TNV106T	0.709 in. (18 mm)	2.756 in. (70 mm)	2.283 in. (58 mm)	2.402 in. (61 mm)		
		Allowance: d1 d2						
		Locally Manufactured						
9	Flex-Hone (For Preparation of Cylinder Walls)	Model	Yanmar Part No.		Cylinder Bore		 <p style="text-align: right;">0000823</p>	
		3TNV82A	129400-92420		3.071 - 3.307 in. (78 - 84 mm)			
		3TNV88, 4TNV88, 4TNV94L	129400-92430		3.268 - 3.740 in. (83 - 95 mm)			
		4TNV98	129400-92440		3.504 - 3.976 in. (89 - 101 mm)			
		4TNV106, 4TNV106T	129400-92450		3.740 - 4.252 in. (95 - 108 mm)			
10	Piston Ring Compressor (For Installing Piston)	Yanmar Part No. 95550-002476 The Piston Insertion Tool is Applicable for 2.362 - 4.921 in. (60 - 125 mm) Diameter Pistons					 <p style="text-align: right;">0000824</p>	
11	Piston Ring Expander (For Removal / Installation of Piston Ring)	Available Locally					 <p style="text-align: right;">0000825</p>	

Note: If the valves are to be reused, identify them so they can be installed in their original location.

8. Turn the cylinder head so the exhaust port side faces down. Remove the intake and exhaust valves (**Figure 6-13, (6)**) from the cylinder head.
9. Remove the valve stem seals (**Figure 6-13, (5)**).

Removal of Valve Guides

Note: Removal of the valve guides should be postponed until inspection and measurement procedures have been performed. See *Inspection of Valve Guides* on page 6-39.

1. If the valve guides were not within specifications, use a drift pin and hammer to drive the valve guides (**Figure 6-14, (1)**) out of the cylinder head.

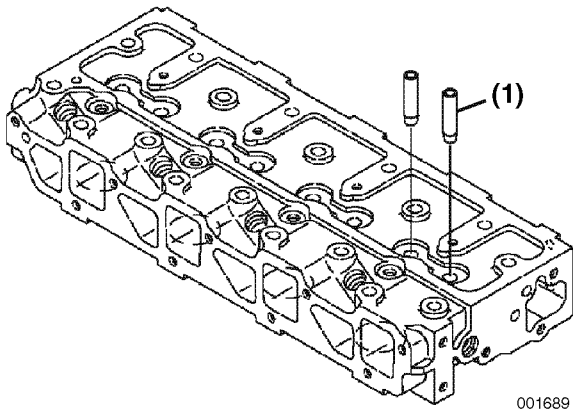

Figure 6-14

001689

Cleaning of Cylinder Head Components

WARNING

FUME / BURN HAZARD!

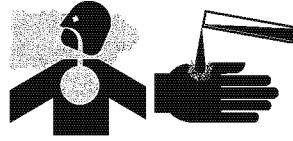

- Always read and follow safety related precautions found on containers of hazardous substances like parts cleaners, primers, sealants and sealant removers.

- Failure to comply could result in death or serious injury.

Thoroughly clean all components using a non-metallic brush and an appropriate solvent. Each part must be free of carbon, metal filings and other debris.

Inspection of Cylinder Head Components

Visually inspect the parts. Replace any parts that are obviously discolored, heavily pitted or otherwise damaged. Discard any parts that do not meet its specified limit.

NOTICE

Any part which is found defective as a result of inspection or any part whose measured value does not satisfy the standard or limit must be replaced.

NOTICE

Any part determined to not meet the service standard or limit before the next service, as determined from the state of current rate of wear, should be replaced even though the part currently meets the service standard limit.

- 1 – Crankcase Breather Cover
- 2 – Diaphragm Spring
- 3 – Diaphragm Cup
- 4 – Crankcase Breather Diaphragm
- 5 – Oil Fill Cap
- 6 – Valve Cover Nut
- 7 – Valve Cover Nut O-Ring
- 8 – Valve Cover Gasket
- 9 – Support Bolt
- 10 – Rocker Arm Shaft Support
- 11 – Wave Washer
- 12 – Fuel Injector Retainer Bolt
- 13 – Valve Adjusting Screw (Primary)
- 14 – Valve Adjusting Screw Lock Nut (Primary)
- 15 – Rocker Arm Shaft Aligning Stud
- 16 – Fuel Injector Retainer
- 17 – Valve Stem Seal
- 18 – Valve Guide
- 19 – Cylinder Head
- 20 – Intake Valve
- 21 – Exhaust Valve
- 22 – Cylinder Head Gasket
- 23 – Fuel Injector Nozzle Protector
- 24 – Fuel Injector Nozzle Seat
- 25 – Valve Spring
- 26 – Valve Bridge Guide
- 27 – Spring Retainer
- 28 – Valve Keepers
- 29 – Valve Bridge
- 30 – Valve Bridge Seat
- 31 – Valve Adjusting Screw Lock Nut (Secondary)
- 32 – Valve Adjusting Screw (Secondary)
- 33 – Push Rod
- 34 – Rocker Arm Shaft
- 35 – Crankcase Breather Components
- 36 – Valve Cover

Disassembly of 4-Valve Cylinder Head

Prepare a clean, flat working surface on a workbench large enough to accommodate the cylinder head assembly. Discard all gaskets, O-rings and seals. Use new gaskets, O-rings and seals on reassembly of the cylinder head.

1. Drain the coolant from the engine into a suitable container. *See Drain, Flush and Refill Cooling System With New Coolant on page 5-23.*

NOTICE

Identify all parts and their location using an appropriate method. It is important that all parts are returned to the same position during the reassembly process.

2. Remove the high pressure fuel injection lines (**Figure 6-40, (1)**). *See Removal of Fuel Injectors on page 7-32.*

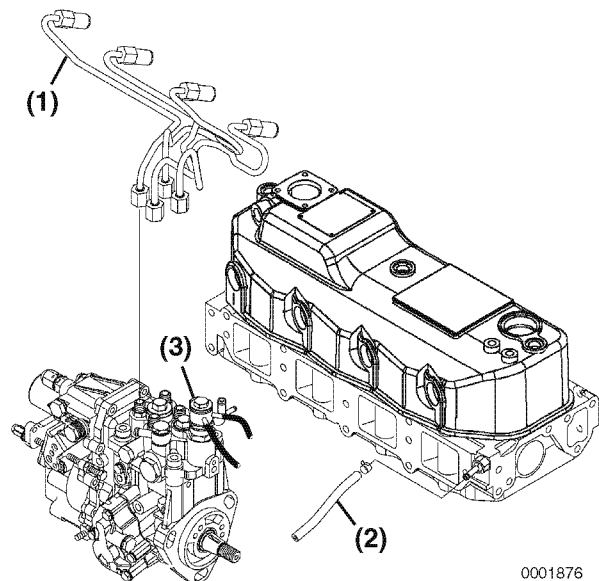

0001876

Figure 6-40

Grind the valve face and/or valve seat as necessary to return them to serviceable condition. Grinding is needed if the valve and valve seat do not contact correctly. Check the valve margin and valve recession after grinding.

If the valve or seat require grinding, lap the valve after grinding. Lap the valve face to the valve seat using a mixture of valve lapping compound and engine oil.

Be sure to thoroughly wash all parts to remove all grinding powder or compound.

Inspection of Valve Springs

Inspect the valve springs. If damage or corrosion is seen, or if measurements exceed the specified limits, replace the springs.

Fractures

Check for fractures on the inside and outside portions of the springs. If the valve spring is fractured, replace the valve spring.

Corrosion

Check for corrosion of spring material caused by oxidation.

Squareness

Use a flat surface and a square to check each spring for squareness (**Figure 6-62**). See *Valve Spring* on page 6-8 for the service limit.

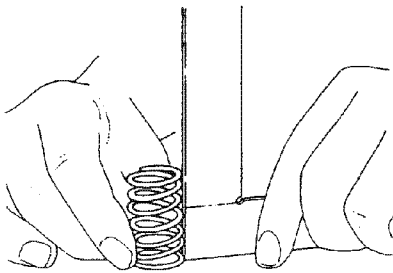

0000201

Figure 6-62

Free Length

Use a caliper to measure the length of the spring (**Figure 6-63**). See *Valve Spring* on page 6-8 for the service limit.

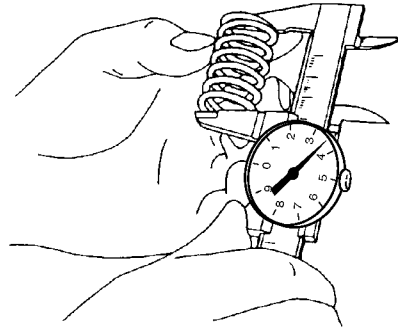

0000200

Figure 6-63

Inspection of Valve Bridges

Visually inspect the contact surface at both ends of the valve bridge (**Figure 6-64, (2)**) for excessive wear or mushrooming.

Remove and inspect the seat (**Figure 6-64, (1)**).

Measure the diameter of the valve bridge guide pin bore in the valve bridge and guide pin (**Figure 6-64, (3)**). See *Rocker Arm and Shaft* on page 6-7 for the service limit.

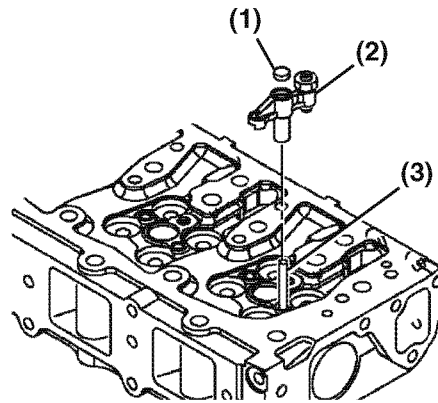

Figure 6-64

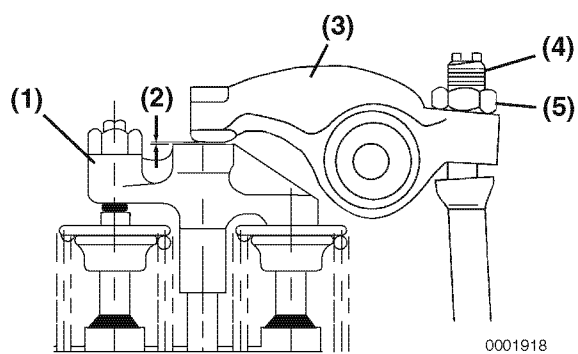

Figure 6-86

12. Hold the adjusting screw (**Figure 6-86, (4)**) while tightening the valve adjusting screw lock nut (**Figure 6-86, (5)**). Recheck the clearance.
13. Apply oil to the contact surface between the adjusting screw and push rod.
14. Rotate the crankshaft to measure and adjust the set of valves. Continue until all valves are measured and adjusted.

Removal of Crankshaft

1. Remove the flywheel (**Figure 6-104, (1)**) from the crankshaft.
2. Remove the bolts from the rear oil seal assembly (**Figure 6-104, (2-3)**). Remove the assembly from the engine.

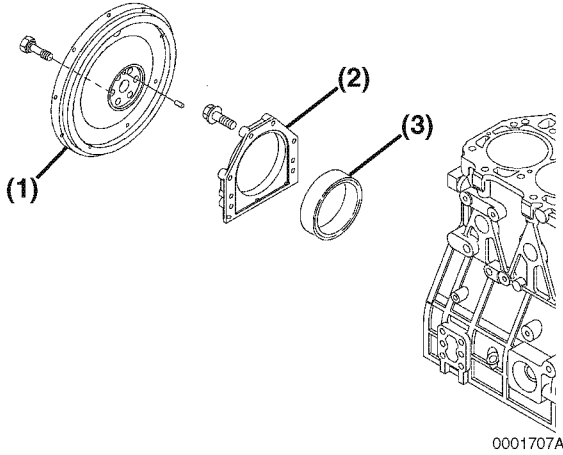

Figure 6-104

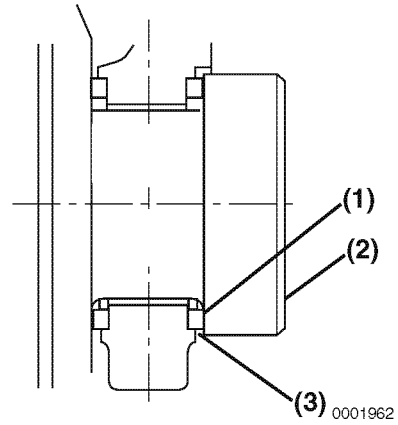

Figure 6-106

3. Before removing the main bearing caps, measure the crankshaft end play. Use either of the following two methods.
 - **Method A:** Install a dial gauge (**Figure 6-105, (1)**) on the cylinder block. Move the crankshaft (**Figure 6-105, (2)**) in and out to measure the end play. Record the measurement.

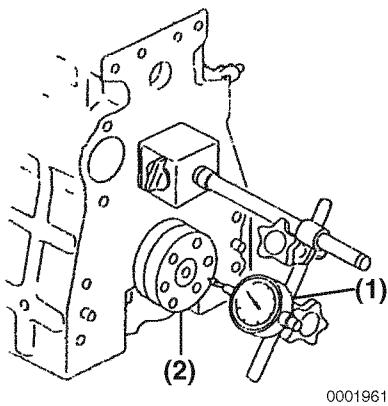
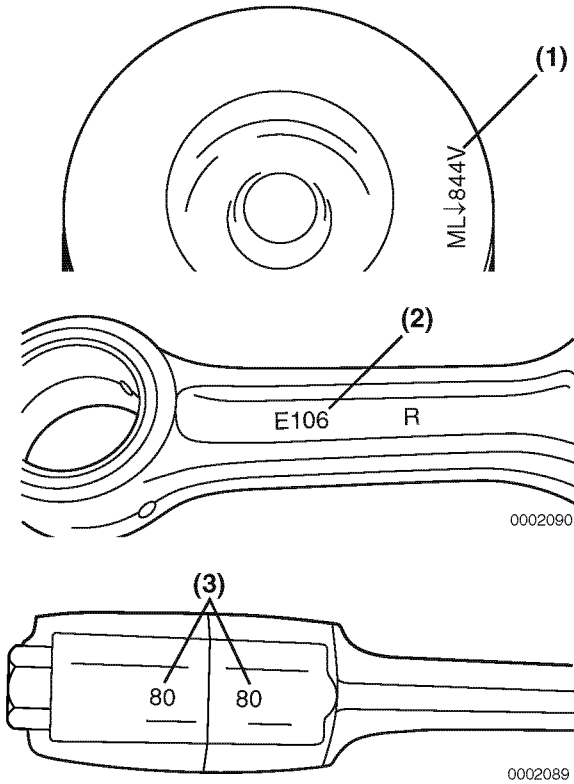

Figure 6-105

- **Method B:** Use a feeler gauge to measure the clearance (**Figure 6-106, (3)**) between the thrust bearing (**Figure 6-106, (1)**) and crankshaft (**Figure 6-106, (2)**). Record the measurement. *See Thrust Bearing on page 6-13 for the service limit.*

Note: The actual appearance of the match marks on the piston and connecting rod may vary, but they will always be in the same locations.



- 1 – Piston Identification Mark
- 2 – Embossed Mark on Connecting Rod
- 3 – Rod and Cap Match Marks

Figure 6-131

Piston Assembly - All TNV models - 82, 84(T), 88, 94, and 98(T)

When correctly assembled, the piston identification mark (Figure 6-132, (2)) stamped into the top of the piston will be on the same side of the connecting rod as the match marks (Figure 6-132, (4)) stamped into the connecting rod and connecting rod cap.

When installed in the cylinder, the piston identification mark (Figure 6-132, (2)) stamped on the top of the piston must face the fuel injection pump side (Figure 6-132, (1)) of the engine and the embossed mark on the connecting rod (Figure 6-132, (3)) must face the flywheel end (Figure 6-132, (5)) of the engine.

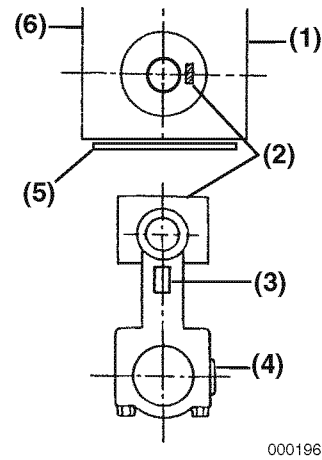

- 1 – Fuel Injection Pump Side of Engine
- 2 – Piston Identification Mark
- 3 – Embossed Mark on Connecting Rod
- 4 – Rod and Cap Match Marks
- 5 – Flywheel End of Engine
- 6 – Camshaft Side of Engine

Figure 6-132

EGR SYSTEM**EGR system**

Applicable engines : 4TNV98-E, 4TNV98-Z

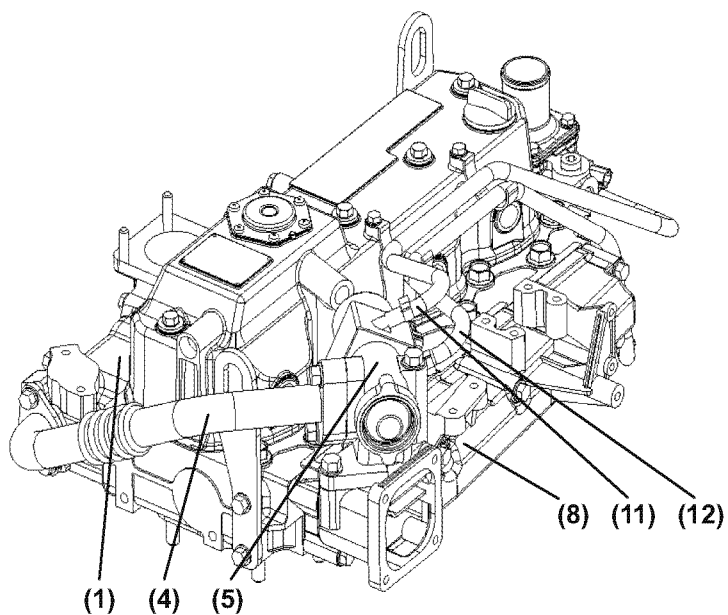
**Figure 6-153**

FUEL SYSTEM

Fuel Injectors.....	7-32
Removal of Fuel Injectors.....	7-32
Testing of Fuel Injectors.....	7-35
Disassembly and Inspection of Fuel Injectors.....	7-36
Adjusting Fuel Injector Pressure.....	7-37
Reassembly of Fuel Injectors.....	7-38
Installation of the Fuel Injectors.....	7-38

- | | |
|---|---|
| 1 – High-Pressure Fuel Injection Lines | 9 – Coolant Lines for Cold Start Device |
| 2 – Fuel Return Line | 10 – Fuel Injection Pump Insulator |
| 3 – Fuel Injector | 11 – Fuel Injection Pump |
| 4 – Front Plate or Timing Gear Case | 12 – Rear Fuel Injection Pump Support |
| 5 – Gear Case Cover | 13 – Fuel Filter / Water Separator |
| 6 – Fuel Injection Pump Drive Gear Nut | 14 – Electric Fuel Supply Pump |
| 7 – Lock Washer | 15 – Fuel Filter |
| 8 – Fuel Injection Pump Drive Gear Assembly
(DO NOT remove or loosen the four bolts
that fasten the injection pump drive gear to
the injection pump drive gear hub!) | 16 – Fuel Filter Housing |
| | 17 – Stop Solenoid |
| | 18 – Cold Start Device (CSD) |
| | 19 – Trochoid Fuel Pump |

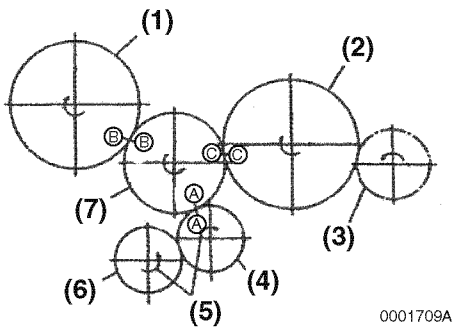

- 1 – Fuel Injection Pump Drive Gear
- 2 – Camshaft Drive Gear
- 3 – Auxiliary Drive Gear (Optional)
- 4 – Crankshaft Drive Gear
- 5 – Direction of Rotation
- 6 – Oil Pump Drive Gear (4TNV94L - 4TNV106)
- 7 – Idler Gear

Figure 7-25

3. Install a new O-ring on the pump mounting flange. Apply grease to the O-ring to hold it in place during installation of the injection pump.

Note: Ensure the tapered surface of the fuel injection pump shaft is clean and dry.

4. Align the key on the fuel injection pump shaft with the keyway in the fuel injection pump drive gear hub. Reinstall the fuel injection pump into the fuel injection pump drive gear and gear housing. Reinstall the pump retaining nuts finger tight.
5. Reinstall the fuel injection pump drive gear lock washer (Figure 7-26, (2)) and nut (Figure 7-26, (1)). Do not lubricate the threads of the nut or shaft. Hold the crankshaft pulley bolt with a socket wrench and tighten the drive gear nut to the specified torque. See *Special Torque Chart* on page 7-7.

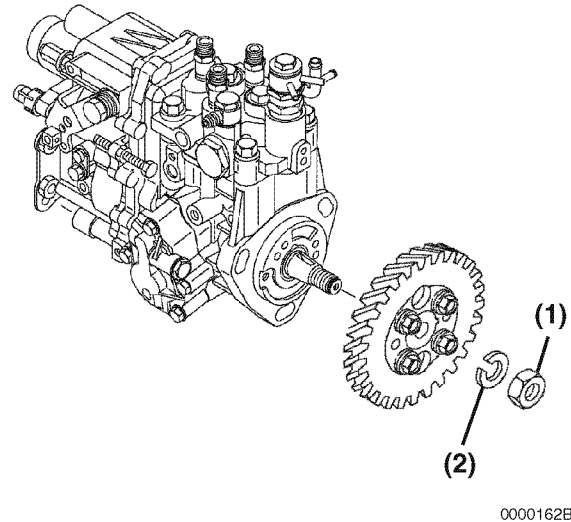

Figure 7-26

If reinstalling the original fuel injection pump:

- Align the reference marks (Figure 7-27, (1)) previously made on both the fuel injection pump mounting flange and gear case or front plate.

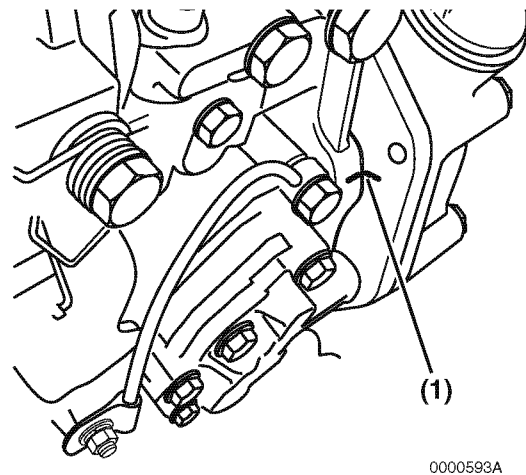

Figure 7-27

- Tighten the fuel injection pump retaining nuts to specification. See *Special Torque Chart* on page 7-7.

9. Tighten the fuel injection pump mounting nuts and rear bracket(s).
10. Remove the dial indicator and adapter. Replace the plug in the pump plunger opening and tighten it to specification. If removed, install the intake manifold and pump insulator. Tighten the high-pressure injection line nuts to specification. Open the fuel supply valve, remove the clamp from the fuel return line and prime the fuel system. Operate the engine and check it for leaks.

Note: To prevent “rounding” the fuel line nuts always use a “line” or “flare nut” wrench. When loosening the fuel line nuts, always hold the fuel injection pump delivery valves with a “back up” wrench to prevent loosening.

- Loosen the fuel line nuts at the fuel injectors and then at the fuel injection pump.

NOTICE

Remove or install the high-pressure fuel injection lines as an assembly whenever possible. Disassembling the high-pressure fuel injection lines from the retainers or bending any of the fuel lines will make it difficult to reinstall the fuel lines.

FUEL INJECTORS

Removal of Fuel Injectors

2-Valve Cylinder Head

1. Close any fuel valves in the fuel supply line.
2. Remove the high-pressure fuel injection lines as an assembly (**Figure 7-50, (1)**).

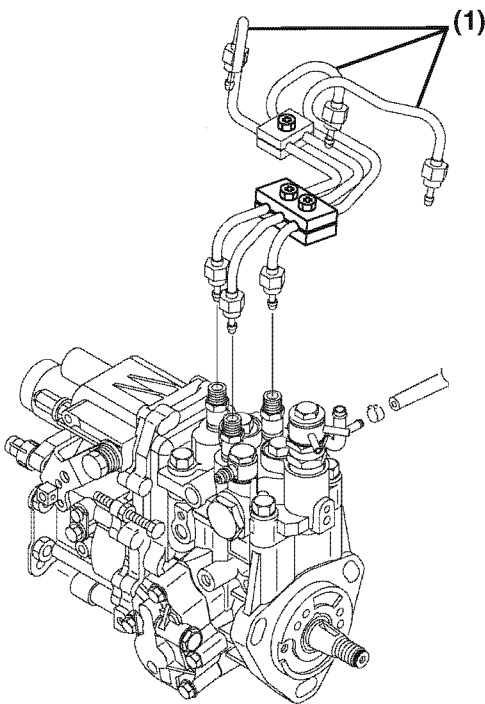

0000154A

Figure 7-50

3. Remove the return fuel hoses (**Figure 7-51, (1)**) from one side of each fuel injector.
4. Remove the bolts and washers that secure the fuel injector retainers (**Figure 7-51, (2)**) to the cylinder head.
5. Remove the fuel injector retainer.

This Page Intentionally Left Blank

This Page Intentionally Left Blank

- Remove the oil pressure regulator valve (Figure 9-7, (1)) from the oil pump cover (Figure 9-7, (2)).

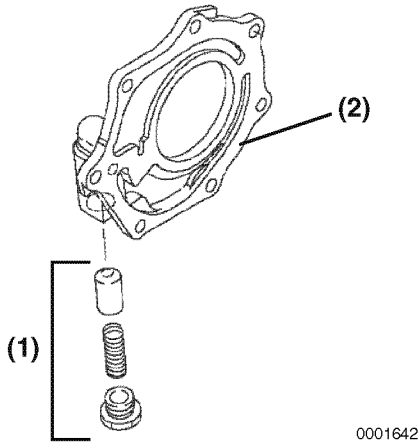

Figure 9-7

Cleaning and Inspection

Wash the oil pump cover, the oil pressure regulator valve, the oil pump cavity and the inner and outer rotors. Inspect the parts for wear or damage. Replace as necessary.

Note: If the oil pump cavity is damaged, the gear case cover must be replaced.

NOTICE

If any oil pump component clearance exceeds its limit, the oil pump must be replaced as an assembly.

Check Outer Rotor Outside Clearance

- Reinstall the outer and inner rotors. The dots on the rotor faces must face "up." Make sure that the pilot on the back of the inner rotor fits into the bore of the oil pump cavity and the top surface of the inner rotor is flush with the top surface of the outer rotor.
- Determine the outside clearance of the outer rotor. Insert a feeler gauge between the outer rotor (Figure 9-8, (1)) and the gear case oil pump cavity (Figure 9-8, (2)).

Record the measurement(s) and see *Outer Rotor Outside Clearance* on page 9-5 for the service limits.

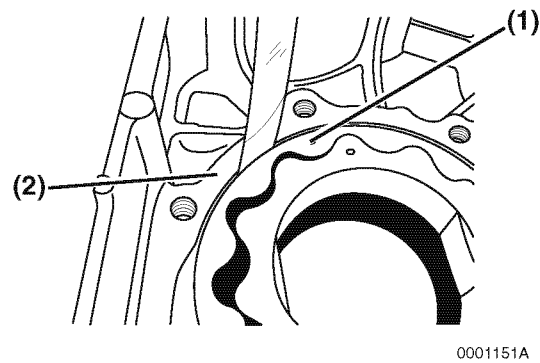

Figure 9-8

Outer Rotor to Inner Rotor Tip Clearance

Determine the outer rotor to inner rotor tip clearance. Insert a feeler gauge between the top of an inner rotor tooth (Figure 9-9, (1)) and the top of an outer rotor tooth (Figure 9-9, (2)) and measure the clearance.

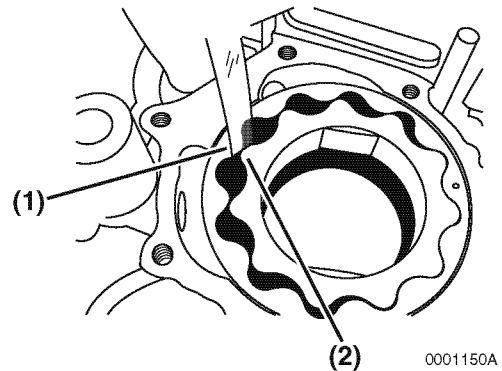

Figure 9-9

Record the measurement(s) and see *Outer Rotor to Inner Rotor Tip Clearance* on page 9-5 for the service limits.

This Page Intentionally Left Blank

PERIODIC INSPECTION

Inspect the turbocharger at regularly scheduled intervals (for reference).

Application	Inspection interval (reference)					
	200 hours	400 hours	500 hours	800 hours	1000 hours	2000 hours
Construction Equipment			First 6 months or 500 hrs		First 12 months or 1000 hrs	Every 24 months or 2000 hrs
Farm Equipment	First 6 months or 200 hrs	First 12 months or 400 hrs		Every 24 months or 800 hrs		
Engine Oil and Filter Replacement	Based on engine operation manual					

Visual Inspection

1. Check for indications of oil leaks at the oil inlet and outlet lines. Repair or replace the oil lines as needed.
2. Inspect the air inlet connection to the turbocharger's turbine side for cracks or broken hardware. Repair or replace the connection as needed.
3. Inspect the exhaust outlet connection to the turbocharger's compressor side for cracks or broken hardware. Repair or replace the connection as needed.

Inspection of Rotor Rotation

1. With the engine cool and not operating, manually rotate the rotor. Smooth rotation is normal. Any catching or resistance to rotation is an indication of abnormal operation. Replace the turbocharger or have it repaired by a qualified repair facility.
2. Start the engine.
3. After the engine reaches normal operating temperature, place a stethoscope firmly against the turbocharger case.
4. Increase the rpm gradually. A high-pitched sound, occurring at intervals of two or three seconds, is an indication of abnormal operation. Replace the turbocharger or have it repaired by a qualified repair facility.

Inspection of Rotor Play

To inspect the rotor, the turbocharger must be removed. Inspect for maximum rotor end play and run-out limits before reinstalling.

Removal of Turbocharger

1. Shut down the engine and allow the turbocharger to cool. Remove the exhaust outlet connection from the turbocharger housing.
2. Remove the air inlet connection from the turbocharger housing.

NOTICE

Do not allow any material to fall into the oil lines or the oil inlet and outlet ports of the turbocharger.

3. Remove the inlet and outlet oil lines from the turbocharger. Plug the lines and ports with tape to prevent contamination. Discard the sealing washers and O-rings. Inspect the oil lines and replace if damaged.
4. Remove the turbocharger mounting nuts from the mounting studs. Lift the turbocharger from the engine and place it on a clean, level working surface.
5. Discard the turbocharger exhaust manifold gasket.

STARTER MOTOR COMPONENTS

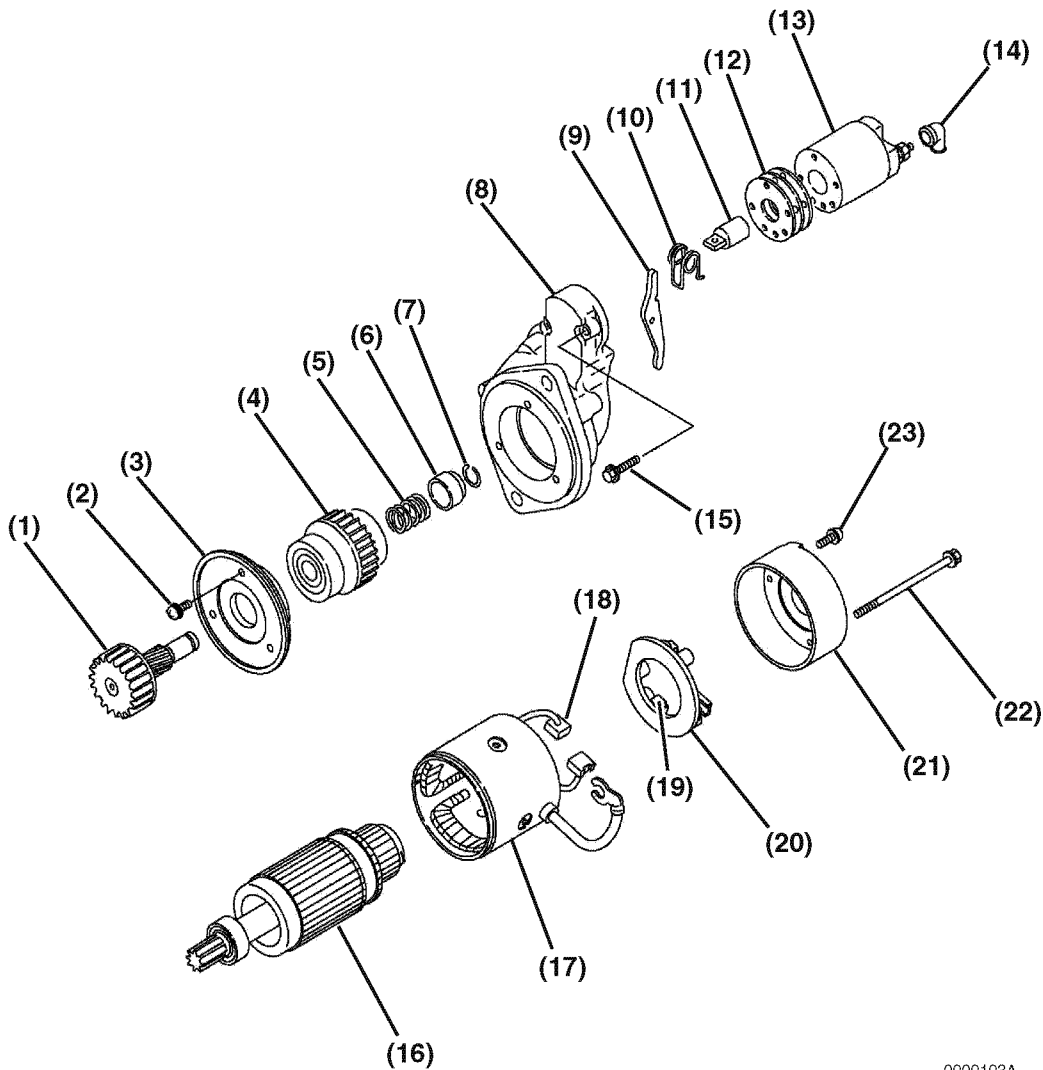

0000103A

- | | |
|---|---|
| <ul style="list-style-type: none"> 1 – Pinion Shaft 2 – M4 Bolts (3 used) 3 – Bearing Retainer 4 – Pinion Clutch Assembly 5 – Return Spring 6 – Pinion Stop 7 – Retaining Ring 8 – Gear Housing 9 – Shift Lever 10 – Torsion Spring 11 – Plunger 12 – Dust Covers (Shims) | <ul style="list-style-type: none"> 13 – Magnetic Switch Assembly (Solenoid) 14 – Cover 15 – M6 Bolts (2 used) 16 – Armature Assembly 17 – Field Coil Assembly 18 – Positive (+) Brushes 19 – Negative (-) Brushes 20 – Brush Holder Assembly 21 – Rear Cover 22 – M5 Through Bolts (2 used) 23 – M4 Bolts (2 used) |
|---|---|

Figure 11-1

- If the measured L dimension is outside the standard range, adjust the dust covers to obtain the standard range. Dust covers **(Figure 11-34, (1))** are available in 0.020 in (0.5 mm) and 0.031 in (0.8 mm) thicknesses.

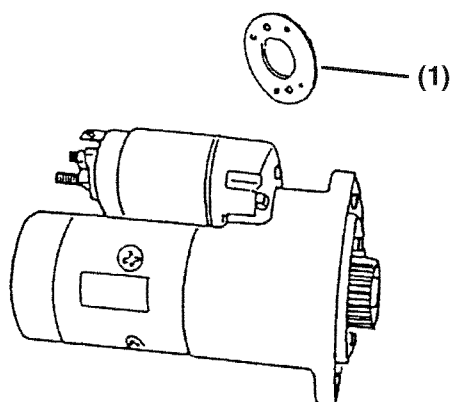

0000133

Figure 11-34

No-Load Test

Test the characteristics of the starter motor by performing a no-load test.

NOTICE

The starter motor can be damaged if operated continuously longer than 10 seconds while performing the no-load test.

- Secure the starting motor in a vise or other suitable fixture.
- Connect an ammeter **(Figure 11-35, (1))** in series between the battery positive (+) terminal **(Figure 11-35, (2))** and the main positive (+) terminal **(Figure 11-35, (3))** on the starter motor.

Note: The ammeter and all wire leads used in this test must have a capacity equal to or greater than the amperage draw specification for the starter motor being tested.

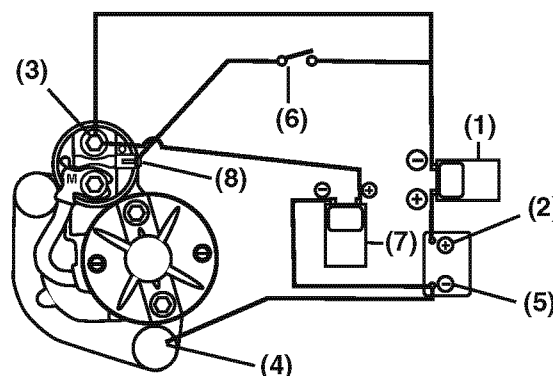

0002127A

Figure 11-35

- Connect a wire lead between the mounting base of the starter motor **(Figure 11-35, (4))** and the battery negative terminal **(Figure 11-35, (5))**.
- Connect a voltmeter **(Figure 11-35, (7))** to the battery negative (-) terminal **(Figure 11-35, (5))** and the main positive (+) battery terminal **(Figure 11-35, (3))** on the starter motor.
- Install a switch **(Figure 11-35, (6))** in a circuit between the battery positive (+) terminal **(Figure 11-35, (2))** and the starter magnetic switch (solenoid) terminal **(Figure 11-35, (8))** on the starter motor.
- Use a suitable tachometer to monitor the rpm of the starter.
- Turn the switch to the ON position. Monitor the rpm, amperage draw and voltage. For test specifications, see 3TNV82A to 4TNV88 - Standard and Optional and 4TNV94L to 4TNV106T - Standard and Optional on page 11-4 for the appropriate starter motor.

CLICK HERE TO **DOWNLOAD** THE COMPLETE MANUAL

- Thank you very much for reading the preview of the manual.
- You can download the complete manual from: www.heydownloads.com by clicking the link below



- Please note: If there is no response to CLICKING the link, please download this PDF first and then click on it.

CLICK HERE TO **DOWNLOAD** THE COMPLETE MANUAL