



EXCAVATOR

E215

**SERVICE
MANUAL**

87360601 NA

Issued 01-2006



CLICK HERE TO **DOWNLOAD** THE COMPLETE MANUAL

- Thank you very much for reading the preview of the manual.
- You can download the complete manual from: www.heydownloads.com by clicking the link below



- Please note: If there is no response to CLICKING the link, please download this PDF first and then click on it.

CLICK HERE TO **DOWNLOAD** THE COMPLETE MANUAL

CHAPTER 1

E215

CRAWLER EXCAVATORS

**GENERAL INFORMATION AND
SAFETY**

1.4 INTERNATIONAL UNIT CONVERSION SYSTEM

INTRODUCTION

NOTE: Information based on MARKS' STANDARD HANDBOOK FOR MECHANICAL ENGINEERS

Although this manual includes International System of Unit and Foot-Pound System of Units, if you need SI unit, refer to the following international system of units.

Given is an excerpt of the units that are related to this manual.

1. Etymology of SI Unites

French: Le Systeme International d' Unites

English: International System of Units

2. Construction of SI Unit System

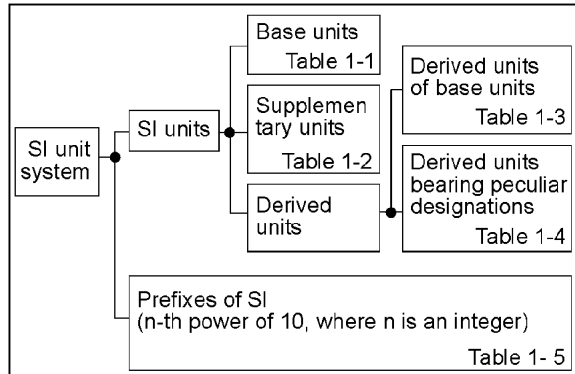

SPW01000007E01

Figure 2

1. Base units

QUANTITY	UNIT	SYMBOL
Length	meter	m
Mass	kilogram	kg
Time	second	s
Electric current	ampere	A
Thermodynamic temperature	kelvin	K
Amount of substance	mol	mol
Luminous intensity	candela	cd

2. Derived Units

QUANTITY	UNIT	SYMBOL
Area	square meter	m ²
Volume	cubic meter	m ³
Velocity	meter per second	m/s
Acceleration	meter per second squared	m/s ²
Density	kilogram per cubic meter	kg/m ³

3. Supplementary units

QUANTITY	UNIT	SYMBOL
Plane angle	radian	rad
Solid angle	steradian	sr

4. Derived Units bearing Peculiar Designations

QUANTITY	UNIT	SYMBOL	FORMULA
Frequency	hertz	Hz	1/s
Force	newton	N	kg · m/s ²
Pressure and Stress	pascal	Pa	N/m ²
Energy, Work and Quantity of heat	joule	J	N·m
Power	watt	W	J/s
Quantity of electricity	coulomb	C	A·s
Electric potential difference, Voltage, and Electromotive force	volt	V	W/A
Quantity of static electricity and Electric capacitance	farad	F	C/V
Electric resistance	ohm	Ω	V/A
Celsius temperature	Celsius degree or degree	°C	(t+273.15)K
Illuminance	lux	lx	l m/m ²

5. Prefixes of SI

PREFIX	SYMBOL	MULTIPLICATION FACTORS
giga	G	10 ⁹
mega	M	10 ⁶
kilo	k	10 ³
hecto	h	10 ²
deca	da	10
deci	d	10 ⁻¹
centi	c	10 ⁻²
milli	m	10 ⁻³
micro	μ	10 ⁻⁶
nano	n	10 ⁻⁹
pico	p	10 ⁻¹²

⚠ DANGER ⚠

Always use proper lifting equipment and devices. Use of improper lifting equipment could allow the load to shift or fall causing severe damage, serious injury or death.

⚠ WARNING ⚠

Do not use the counterweight lifting eyes to lift machine.

IMPORTANT: Lifting machine with wider track shoes will tend to shift the Center of Gravity slightly forward, toward the center of the slewing ring.

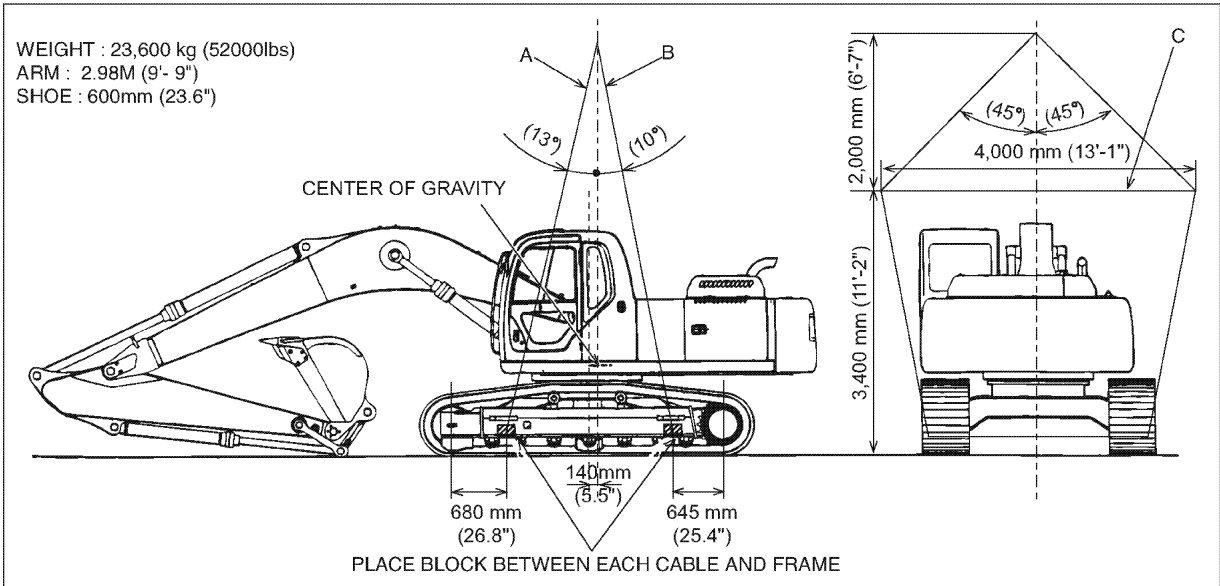

FIGURE 5.6A

A. One 37.5 x 15.2 m Cable B. One 37.5 x 15.1 m Cable C. Two 4.0 m Spreader Bars

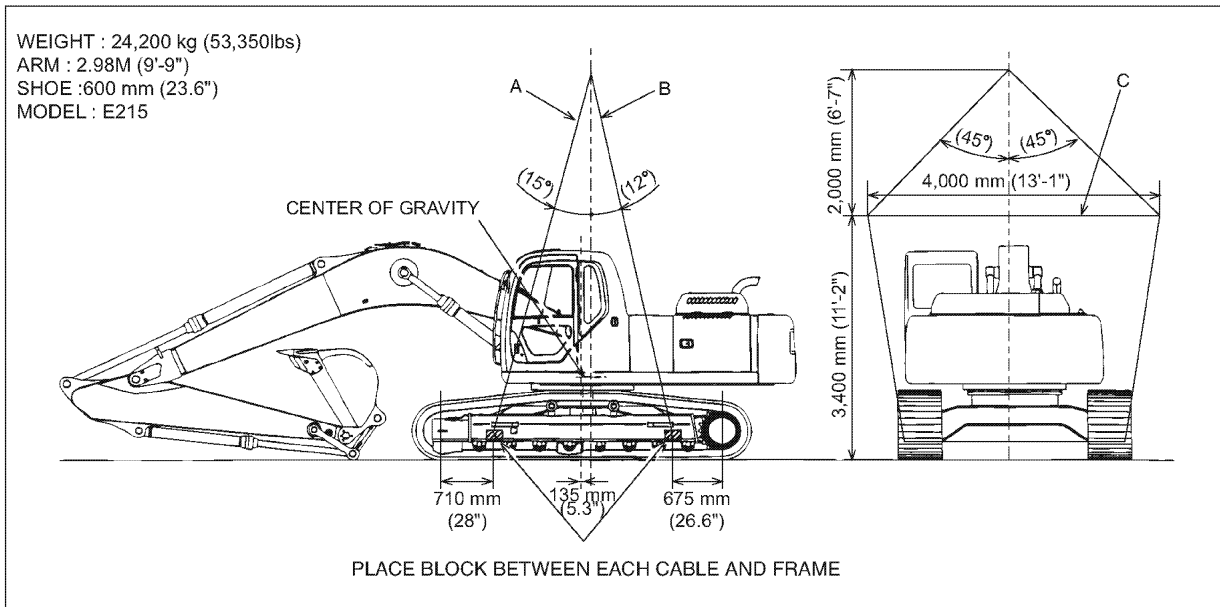

FIGURE 5.6B

A. One 37.5 x 15.5 m Cable B. One 37.5 x 15.3 m Cable C. Two 4.0 m Spreader Bars

CHAPTER 3
E215
CRAWLER EXCAVATORS

SPECIFICATIONS

1-L. LIFTING CAPACITIES FOR EUROPEAN SPEC'S
 RATED OBJECT HANDLING CAPACITIES TABLE
 600 mm Shoe Width

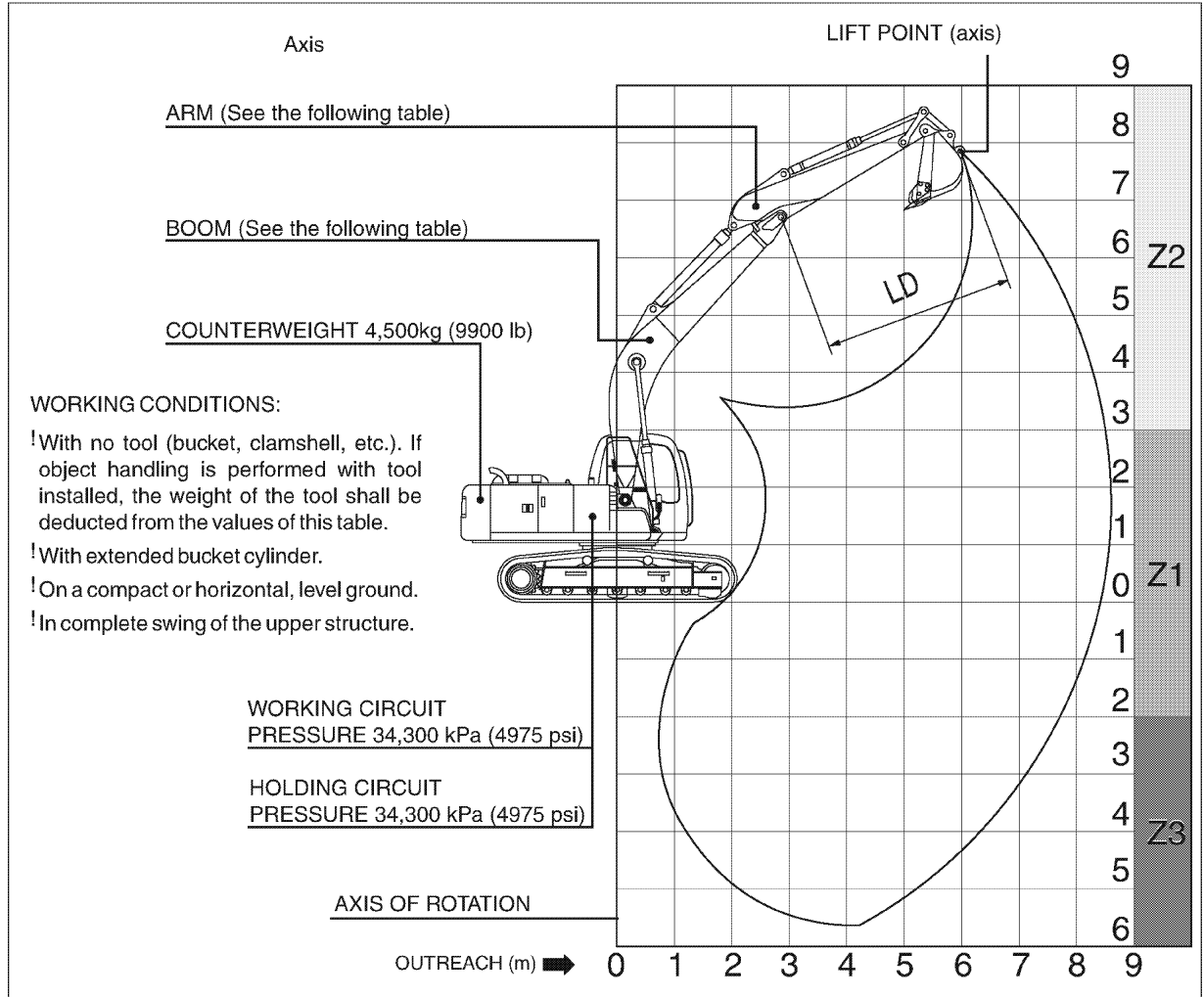

These loads are valid for the height of the considered Zone (Z1, Z2, Z3) for the intended outreach.

BOOM LENGTH 5.65 m		Outreach						
Arm Length	LD*	Zone	3 m	4.5 m	6 m	7.5 m	9 m	Maximum Reach (Boom Foot Height)
2.40 m	2.80 m	Z2	--	5420 kg	4220 kg	2840 kg	--	--
		Z1	6 310 kg		3520 kg	2550 kg	--	2330 kg (8.10 m)
		Z3	10 010 kg		3570 kg	--	--	--
2.94 m	3.33 m	Z2	--	5380 kg	4290 kg	2890 kg	--	--
		Z1	6 650 kg		3480 kg	2490 kg	--	2100 kg (8.59 m)
		Z3	10 630 kg		3490 kg	--	--	--
3.33 m	3.72 m	Z2	--	5300 kg	4350 kg	2920 kg	--	--
		Z1	7 430 kg		3440 kg	2440 kg	--	1940 kg (8.95 m)
		Z3	10 420 kg		3420 kg	2450 kg	--	--

* LD = Distance from Boom point to Hook point

E215 RATED OBJECT HANDLING CAPACITIES TABLE

800 mm Shoe Width

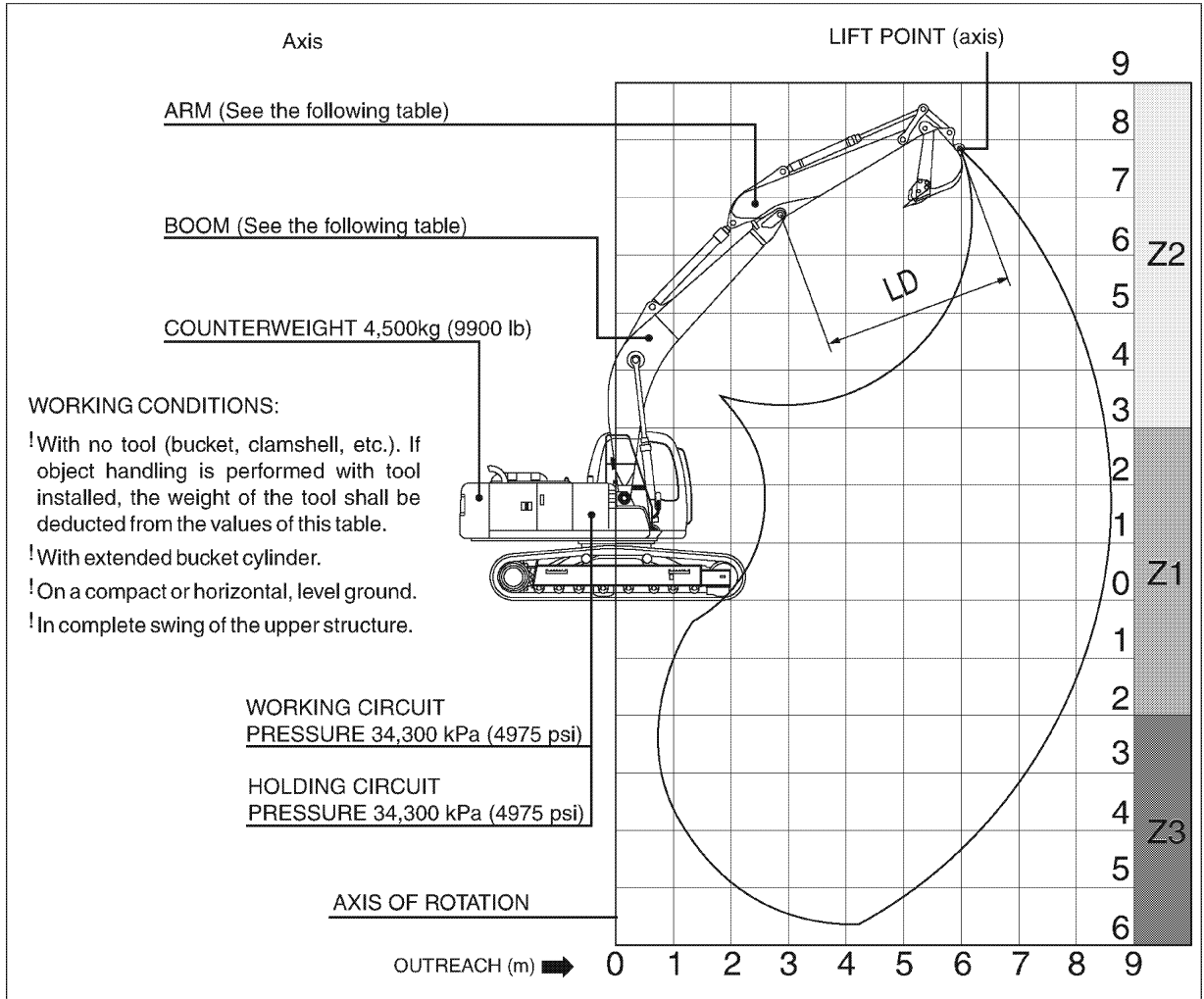

These loads are valid for the height of the considered Zone (Z1, Z2, Z3) for the intended outreach.

BOOM LENGTH 5.65 m		Outreach						
Arm Length	LD*	Zone	3 m	4.5 m	6 m	7.5 m	9 m	Maximum Reach (Boom Foot Height)
2.40 m	2.80 m	Z2	--	6380 kg	4850 kg	3300 kg	--	--
		Z1	6 310 kg		4140 kg	3010 kg	--	2740 kg (8.10 m)
		Z3	10 010 kg		4190 kg	--	--	--
2.94 m	3.33 m	Z2	--	6340 kg	4900 kg	3350 kg	--	--
		Z1	6 650 kg		4100 kg	2940 kg	--	2480 kg (8.59 m)
		Z3	11 580 kg		4110 kg	--	--	--
3.33 m	3.72 m	Z2	--	6260 kg	4530 kg	3320 kg	--	--
		Z1	7 430 kg		4050 kg	2890 kg	--	2300 kg (8.95 m)
		Z3	12 370 kg		4030 kg	2910 kg	--	--

* LD = Distance from Boom point to Hook point

2-D. DIGGING FORCES

Arm Length	6.35 M (20'-10")
Bucket digging force	8,120 Kgf (17,900 lbf)
Arm crowding force	5,410 Kgf (11,930 lbf)

2-E. BUCKET SELECTION CHART

Application	Capacity m³ (ydr³)	Width cm (inches)
General Purpose	0.34 (0.44)	61 (24)
	0.44 (0.58)	76 (30)
	0.56 (0.73)	91 (36)
Ditch Cleaning	0.38 (0.50)	122 (48)
	0.48 (0.63)	152 (60)
	0.57 (0.75)	183 (72)

CHAPTER 4

E215

CRAWLER EXCAVATORS

ATTACHMENT DIMENSIONS

2.2 ARM MAINTENANCE STANDARD
(1) Clearance of pin and bushing

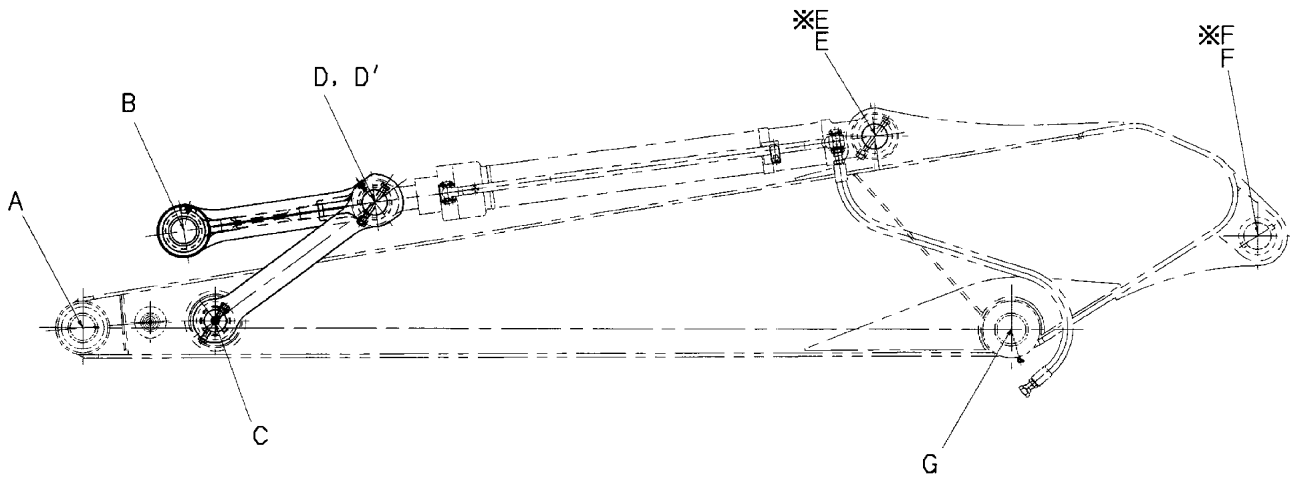

Fig. 2-2 Clearance of pin and bushing on arm section

CHAPTER 11
E215
CRAWLER EXCAVATOR

TOOLS

5. SPECIAL SPANNER FOR TUBE

Table 5-1

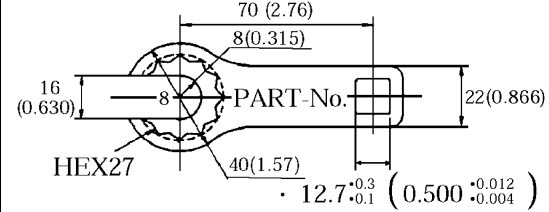
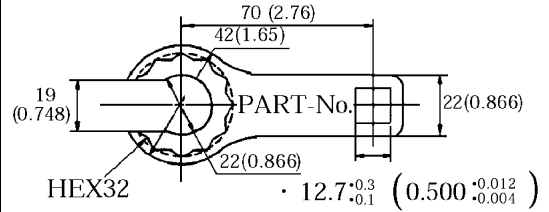
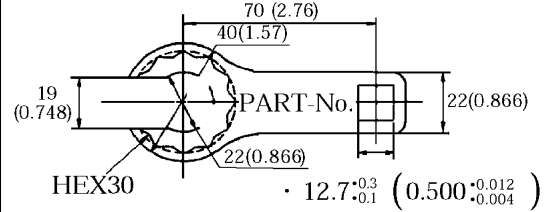
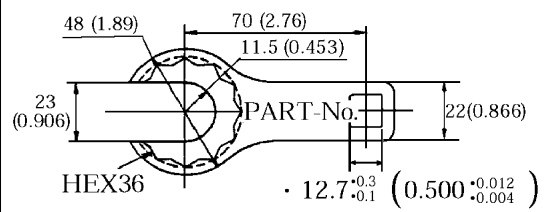
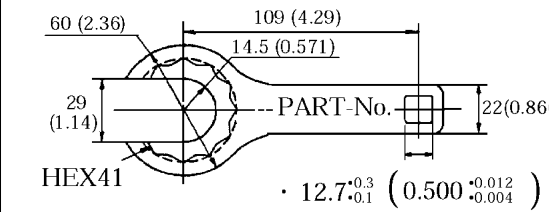
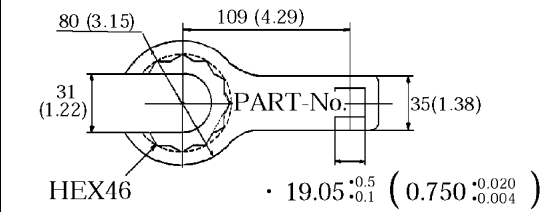
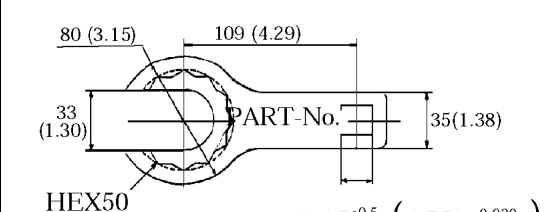
Applicable tube diameter mm•(in)	Part No.	HEX mm	Drawing of a special spanner•mm (in)
15 (0.591)	2421T160	27	
18 (0.709)	2421T138	32	
22 (0.866)	2421T129	30	
22 (0.866)	2421T130	36	
28 (1.10)	2421T115	41	
28 (1.10)	2421T231	46	
32 (1.26)	2421T232	50	



CHAPTER 12
STANDARD MAINTENANCE TIME TABLE
TABLE OF CONTENTS

1. STANDARD WORKING MAINTENANCE TIME TABLE	
01 Attachments	1-1
02 Cab and Guard	1-2
03 Swing Frame Excluded Time	1-3
04 Travel System	1-5
06 Electrical Equipment	1-6
2. STANDARD WORKING MAINTENANCE TIME TABLE	
2.1 COOLING SYSTEM	2-1
2.2 Electrical System	2-2
2.3 Engine	2-5
2.4 Fuel System	2-13

2. STANDARD WORKING TIME TABLE ENGINE MAINTENANCE

Introduction

This standard working time table provides time required for maintenance (if the work is carefully carried out) under the following condition :

- Special designated tools are used.
 - Genuine parts are used.
 - Correct working procedures are observed.
 - The engine is mounted correctly to the machine.
1. The working hours given in this table can not be applied to special machine construction.
 2. Special equipment not listed in this table has not been time calculated.

If this type of work is performed, list reasons on the Claim Application Sheet in detail and submit .

(Note 1) Unit of working time

The working time is given in 6 minutes=0.1 hour in the decimal system.

(Note 2) Applicable models : E215



NAME OF WORK	PROBLEM	
Connecting rod		
Correcting bend of connecting rod. (1 pc. single)	Connecting rod is bent.	•
Replacing connecting rod bearings. (all)	Bearings are worn. Bearings are seized.	4.8
Replacing connecting rod bearings. (1 set) Add 0.4hr. as one rod increases.	Bearing is worn. Bearing is seized.	•
Replacing connecting rod bushing. (set by set)	Small end bushing is worn. Small end bushing is seized.	•
Piston		
Detaching/attaching or replacing pistons. (all) (On-machine) •Incl. : (1) Conditioning engine (A). (2) Adjust nozzle. Add 0.5hr. each time one piston decreases.	Piston is broken. Piston is seized. Oil consumption of engine is large. Piston system in general is out of order. Piston and piston pin make abnormal sound.	17.0
Detaching/attaching or replacing piston rings. (all) (On-machine) •Incl. : (1) Detaching/attaching cylinder head oil pan. (2) Checking and correcting rod. (3) Scraping off carbon. (4) Conditioning engine (A). (5) Adjusting nozzle.	Engine consumes much oil. Piston rings are worn off. Piston rings is broken. Engine oil goes into combustion chamber. Piston system in general is out of order.	16.0
Intake manifold		
Detaching/attaching or replacing inlet manifold. (1 pc) •Incl. : Replacing gasket.	Intake manifold is broken. Intake manifold is blowholed. Gas leaks from intake manifold gasket. Intake manifold system in general is out of order.	1.5
Detaching/attaching or replacing inlet manifold. (one side) •Incl. : Replacing gasket.	Intake manifold is broken. Intake manifold is blowholed. Gas leaks from intake manifold gasket. Intake manifold system in general is out of order.	•
Exhaust manifold		
Detaching/attaching or replacing exhaust manifold. •Incl. : Replacing gasket.	Exhaust manifold is broken. Gas leaks from exhaust manifold gasket. Exhaust manifold system in general is out of order.	1.2
Detaching/attaching or replacing exhaust manifold. (one side) •Incl. : Replacing gasket.	Exhaust manifold is broken. Gas leaks from exhaust manifold gasket. Exhaust manifold system in general is out of order.	•

VERIFICATION OF ENGINE RPM

1. VERIFICATION OF ENGINE RPM

A. Machine Preparation Procedures

1. With safety lock in the lock (up) position. See Figure 5.1.
2. Place the maintenance connector in the release position. See Figure 5.2
3. Place throttle potentiometer to low idle position ; start engine, allow engine to achieve normal operating temperature °C 45~55 (°F 113~145)
4. Check the gauge cluster and confirm that the machine is in the default "M" mode. See Figure 5.3.
5. Locate the screen change switch, depress the switch once to select RPM. Check that engine low and hi RPM are at the proper adjustment. See Figure 5.3.
Refer to chart by model and serial number for specifications.
6. Return Throttle potentiometer to low idle position. Press screen change switch two times to return screen to Monitor System OK.
7. Place front attachment to hydraulic oil check position. See Figure 5.4.
8. Allow engine to idle for two minutes and shut off engine.

2. ENGINE SPEED MEASURED WITH SERVICE DIAGNOSTICS (28 ITEM CHECK)

1. With gauge cluster blank press and hold buzzer stop switch.
2. Turn key switch to on position.
3. Screen Change Switch advances the display each time the screen change switch is pushed.
4. Press the Screen change switch once, diagnostic check of computer will be at screen No. 2. Below.

2	No. 2 E/G SET 2200 MEAS 2201 E/G PRS. LIVE KPSS SW M	No load set rpm Actual rpm LIVE/DEAD indication A/M/B indication
---	--	---

5. Buzzer Stop Switch returns display to previous screen each time switch is pushed.
6. Screen will stay in diagnostic mode until key switch is turned off.

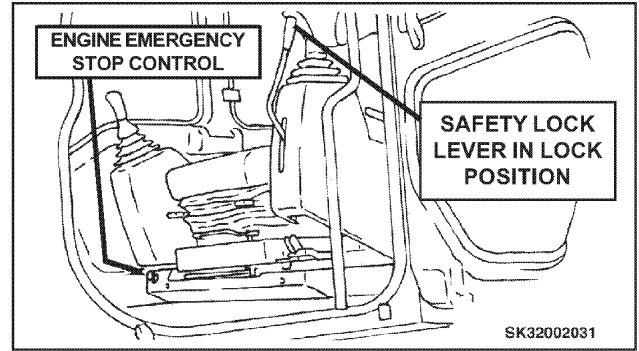

FIGURE 5.1

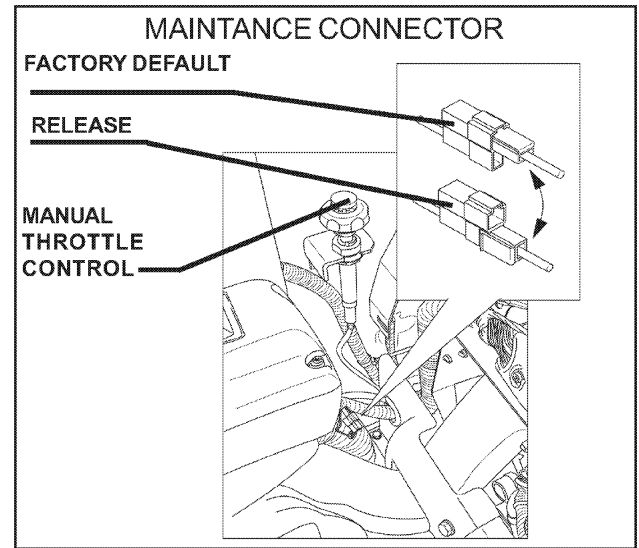

FIGURE 5.2

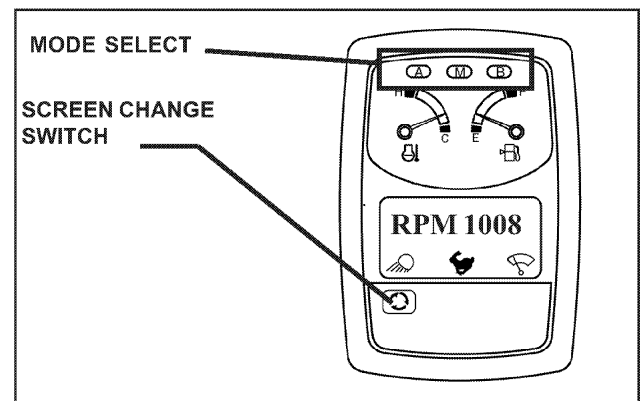

FIGURE 5.3

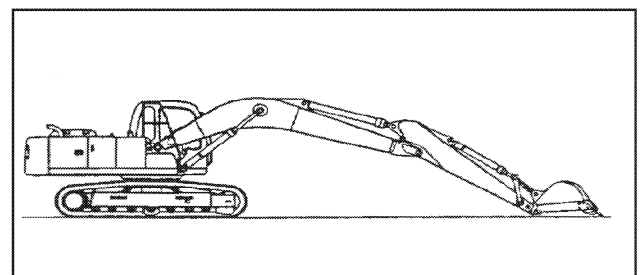

FIGURE 5.4

OVER LOAD RELIEF VALVES

⚠
WARNING
⚠

- **PRECISE ADJUSTMENT OF THE MACHINE'S OVER LOAD RELIEF VALVES IS NOT POSSIBLE ON THE MACHINE.**
- **SHOULD A PROBLEM BE FOUND WITH THE OVER LOAD RELIEF VALVES, IT IS RECOMMENDED TO REPLACE FAULTY OVER LOAD RELIEF VALVES. SUCH ADJUSTMENT COULD VOID WARRANTY.**

G. OR2 Bucket Out Over Load Relief

1. Operate Bucket Out Control until bucket is completely out and hold.
2. Record reading from Pressure Gauge at a1 test port on P1 Main Pump. Compare reading to proper chart for specific machine being tested.
3. Locate OR2 on Main Control Valve, loosen locknut and adjust OR1 to test bench pressure. See Figure 15.27.
4. Secure locknut 2.8 ~3.2 kgf/m² (20~30 ft.lb).

H. OR7 Arm In (DIG) Over Load Relief

1. Operate arm in control until arm is completely in and hold.
2. Record reading from Pressure Gauge at a2 test port on P2 Main Pump. Compare reading to proper chart for specific machine being tested.
3. Locate OR7 on Main Control Valve, loosen locknut and adjust OR7 to test bench pressure. See Figure 15.28.
4. Secure locknut, 2.8 ~3.2 kgf/m² (20~30 ft.lb).

I. OR8 Arm Out Over Load Relief

1. Operate arm out control until arm is completely out, then hold.
2. Record reading from Pressure Gauge at a2 test port on P2 Main Pump. Compare reading to proper chart for specific machine being tested.
3. Locate OR8 on Main Control Valve, loosen locknut and adjust OR8 to test bench pressure. See Figure 15.28.
4. Secure locknut, 2.8 ~3.2 kgf/m² (20~30 ft.lb).
5. Adjust MR - 1 back to specified settings. Verify pressures and that machine operation is correct.

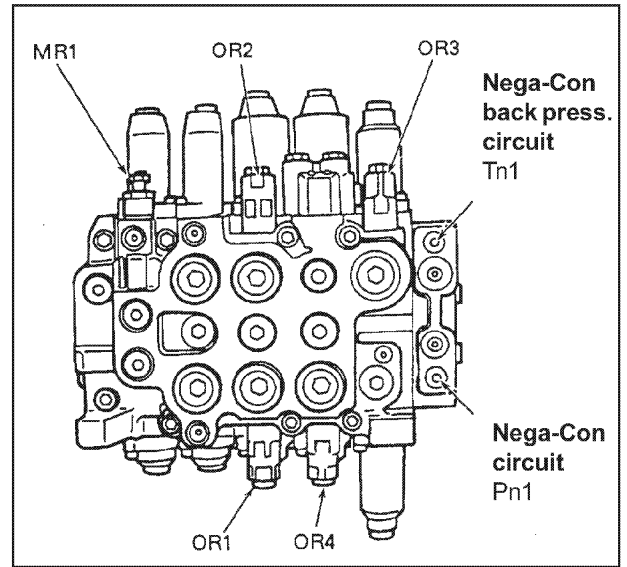

Figure 15.27 *

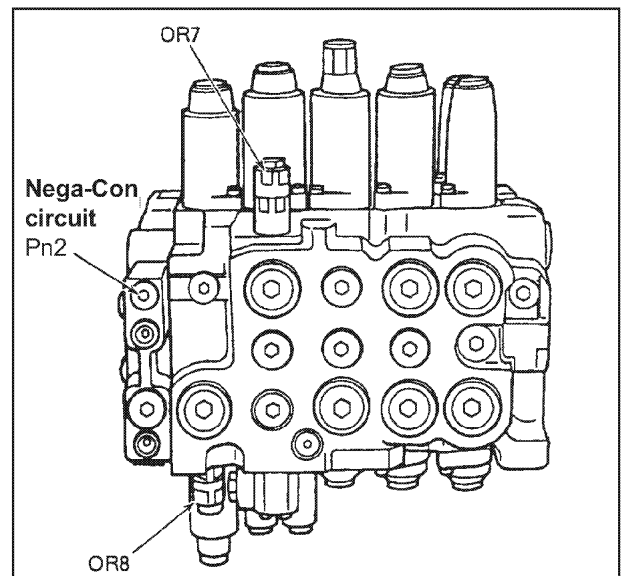

Figure 15.28 *

* Note: Swing Priority not shown

NOTE

Turning Over Load Adjusting Screw
Clockwise One turn
Increases Pressure Approximately
108 kgf/cm² 180 (2560 psi)

SWING BEARING VERTICAL MOVEMENT

UPDOWN VERTICAL MOVEMENT

A. TOOLS AND EQUIPMENT

1. Dial indicator
2. Magnetic Base Assembly

B. MACHINE SETTINGS & SITE CONDITIONS

1. Confirm that the hydraulic oil is approximately 45-55°C (113-131° F).
2. Firm, level testing site.

C. SWING STOPPING TEST

1. Move the machine to a firm, level area.

WARNING

- BE EXTREMELY CAUTIOUS WHILE TAKING READINGS FROM DIAL INDICATOR.
- WEAR APPROVED SAFETY CLOTHES, SHOES AND HARD HAT WHEN PERFORMING MAINTENANCE OR TEST PROCEDURES.

2. Attach dial indicator to the mounting area of swing bearing at the location of a swing bearing mounting bolt. See Figure 4.12.
3. Operate the arm control until the arm is approximately at 90° with boom. See Figure 4.13.
4. Operate the bucket control until bottom of bucket is even with ground level. See Figure 4.13.
5. Adjust boom up or down until bucket is resting on the ground. With boom control, raise the machine until tracks are 450 mm (17.75") off the ground. See Figure 4.13.
6. Set Dial indicator to "0".
7. Operate boom up and arm out controls until arm is completely out. See Figure 4.14.
8. Operate bucket control until bucket is completely out and operate boom until bucket teeth are 450 mm (17.75") from the ground. See Figure 4.14.

9. Record reading from dial indicator and repeat steps 3 through 9 two more times. Compare reading to Up-Down Movement Chart.

10. Swing machine 180° and repeat steps 2 through 9.

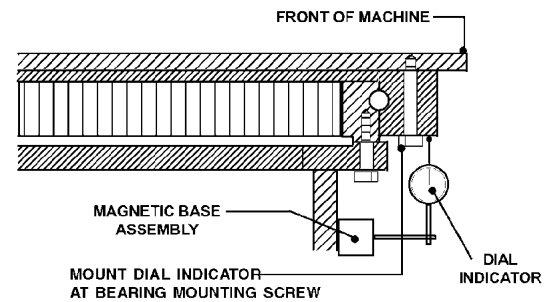

FIGURE 4.12

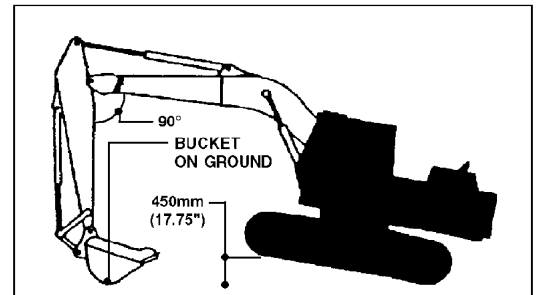

FIGURE 4.13

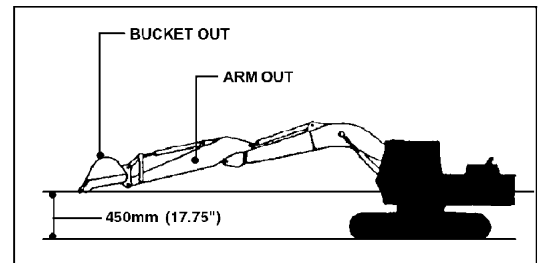

FIGURE 4.14

CH13-25-01

SWING STOPPING SPECIFICATIONS

STANDARD	MAXMOVEMENT
0.5-1.5 (0.020-0.060)	2.0 (0.080)

Unit: mm (inches)

ADJUSTMENT “A” PROCEDURE

MECHATRONIC CONTROLLER

A. CONDITIONS TO USE ADJUSTMENT “A”:

Adjustment “A” procedure must be performed when one or more of the following components have been removed, repaired, adjusted or replaced.

1. Mechatronic controller (CPU)
2. Stepping motor assembly
3. Linkage between stepping motor and engine fuel pump assembly
4. Engine fuel pump assembly
5. Engine
6. When the ROM DATA FAILURE is displayed on the multi display.
7. When the ROM DATA FAILURE and/or MECHATRO SET ERROR are displayed alternately on the multi display.

B. TOOLS & EQUIPMENT REQUIRED FOR CHECKING AND ADJUSTING OF PILOT AND MAIN RELIEF VALVES

- 14 mm spanner wrench
- 13 mm spanner wrench
- 10 mm spanner wrench
- 6 mm Allen wrench
- 1 mm feeler gauge

1. General hand or power tools to remove and replace hydraulic fittings and components.
2. Thermometer to read hydraulic oil temperature.

C. VERIFICATION OF AUTO ACCEL RPM

1. With safety lock in the lock (up) position, See Figure 10.30 B.
2. Maintenance connector in the factory default position. See Figure 10.30 C.
 - a. Turn key switch to start position and start engine. See Figure 10.30 D.
 - b. Place throttle potentiometer to high idle position. See Figure 10.30 D.
 - c. Locate the screen change switch, depress the switch once to select RPM. See Figure 10.31 B.
 - d. Place safety lock lever in the unlock (down) position. See Figure 10.31 C.
 - e. Fully activate pilot control for bucket dig, then release pilot control, wait three seconds and check engine RPM. See Figure 10.30 D.

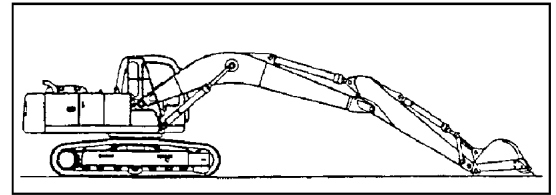

FIGURE 10.30 A

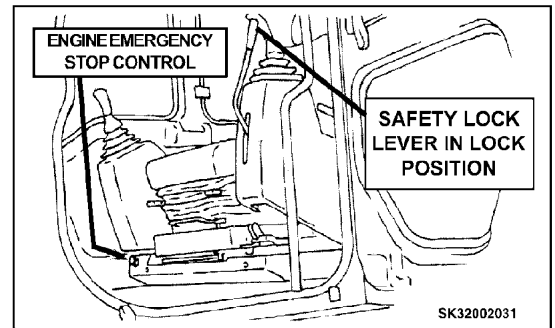

FIGURE 10.30 B

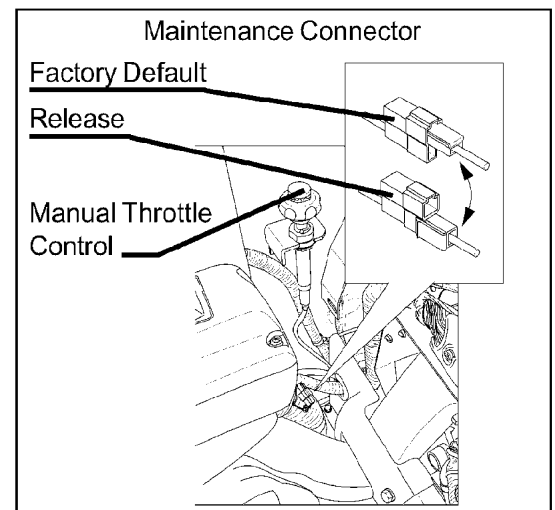

FIGURE 10.30 C

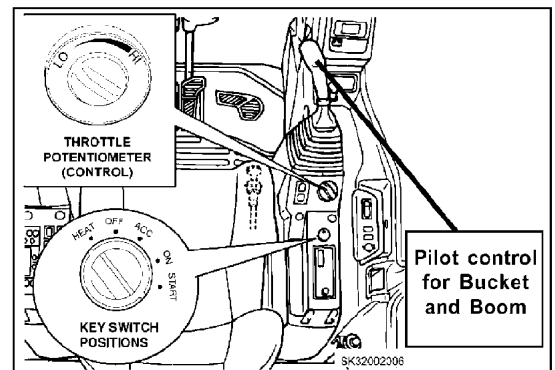



















FIGURE 10.30 D

SERVICE DIAGNOSTIC 28 ITEM CHECK CHART

	Display	Operation procedures			Remarks
High Press. Sensor	No. 14 (Screen No.) PRESS. SENSOR	Control lever at neutral position E/G speed LOW and HIGH common	0.7V / 20k		Note: 0k = 0 kg/cf ² Note: V = Volts
	C-1 PUMP P1 0.7V 20k	E/G speed High idle Boom up and over relief	3.3V / 350k		When control lever is in neutral position you will have minimum val
	C-2 PUMP P2 0.7V 20k	E/G speed High idle plus boost	3.5V / 400k		As you increase the angle of the control lever, the values will increase proportionally.
	No. 15 (Screen No.) PRESS. SENSOR B-16 P1 OPT. 0.5V 0k	Without N & B Piping With N & B Piping	0.0V / 0k 0.5V / 0k	 	If values do not change while operating the control lever, remove connector on the failed low pressure sensor. Then install connector on pressure sensor which is known to work.
Low Press. Sensor	B-17 P2 OPT. 0.5V 0k	With N & B piping when control pedal is depressed fully	5.0V / 30k		If display does not change: FAILURE OF HARNESS
	No. 16 (Screen No.) PRESS. SENSOR B-11 P1 NEGA-CON 2.2V 21k	Control lever neutral position, E/G speed LOW	2.2V / 21k		
	B-12 P2 NEG-CON 2.2V 21k	Control lever neutral position, E/G speed HIGH Control lever at full stroke, E/G speed HIGH	3.0V / 31k 0.5V / 3k or less	 	
	No. 19 (Screen No.) PRESS. SENSOR B-15 BACKRESS. 0.5V 3k	Control lever neutral position, E/G speed LOW Control lever neutral position, E/G speed HIGH Control lever at full stroke, E/G speed HIGH	0.8V / 3k 0.9V / 3k 1.6V / 8k	  	
					
					
					
					
					
					

CHAPTER 21
MECHATRO CONTROL SYSTEM
TABLE OF CONTENTS

1. SUMMARY OF MECHATRO CONTROL SYSTEM

1.1 Mechatro Control System 1-1

1.2 Pump Control 1

1.3 Boom Raise Conflux Control 3

1.4 Arm In Conflux Control 4

1.5 Variable Recycle Control for Light Load (Arm In) 5

1.6 Arm In Anti-cavitation Control 6

1.7 Arm Out Conflux Control 7

1.8 Travel Straight Control 8

1.9.1 Swing Priority Control 9

2. MECHATRO CONTROLLER

2.1 Summary of Mechatro Controller 11

2.2 Self Diagnosis Display Function 14

2.3 Service Diagnosis 15

2.4 Trouble History Diagnosis 17

2.5 Correcting Engine Oil Supply Cumulative Time 18

2.6 Mechatro Control Equipment 20

1.7 ARM OUT CONFLUX CONTROL

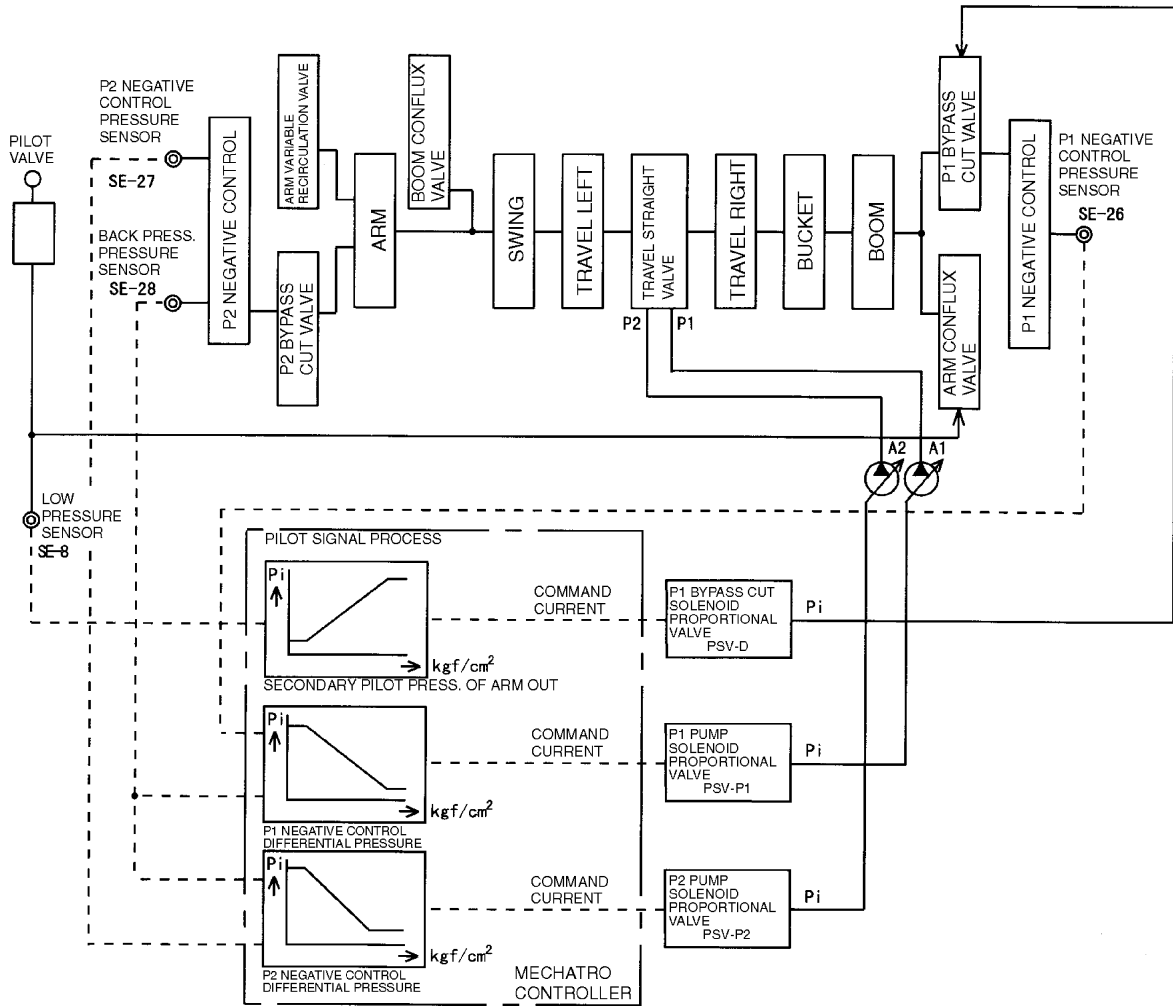

Arm out conflux

- 1) Start arm out operation simultaneously, and arm operation pilot pressure switches arm spool, arm conflux spool and is input into low pressure sensor.
- 2) The voltage output of the low pressure sensor enters the mechatro controller. The controller processes the pilot signal and puts out a current command to the proportional valve for the P1 bypass cut valve according to the voltage input.
- 3) The P1 bypass cut solenoid proportional valve puts out the secondary pilot pressure according to the current command from the mechatro controller and changes over the P1 bypass cut valve of the control valve.
- 4) If the P1 bypass cut valve is changed over, the oil delivered by the P1 pump is combined with the arm line during arm operation.

2.4 TROUBLE HISTORY DIAGNOSIS

The error item detected by the self-diagnosis is stored in the mechatro controller as a history and is displayed on the multidisplay.

- (1) How to display
 - 1) Turn the starter switch 「ON」.
 - 2) Press the buzzer stop switch 5 times in sequence for 10 seconds.

(Example)

CONTENTS	DISPLAY
No errors	NO ERROR
Error detected in the past	00025H B-10 TRAVEL LEFT D-2 P2 BYPASS CUT F-3 TRAVEL 1.2-SPEED

- 3) Transmits the error data (one or many) and hour meter to the gauge cluster.
 - Hour meter and 3 error data are displayed on the screen.
 - If three error data or more exist, display the data three by three in order for every 5 seconds.
- 4) Scrolling pages (Item number)
 - The item number increases each time the work mode select switch is pushed.
 - The item number decreases each time the buzzer stop switch is pushed.

Note :

The system stores all error items at each hour meter reading. To check error items at different hour meter readings, push the workmode change switch or the buzzer stop switch.

- 5) To erase the display, turn the starter switch to 「OFF」 .

- (2) How to cancel the contents of the trouble history

- 1) Display the trouble history mode.
- 2) Press the work mode select switch and the buzzer stop switch for 10 seconds or more concurrently.
- 3) When the erasing is completed, the “NO ERROR” is displayed.
- 4) Turn the starter switch 「OFF」 .

Note :

All the stored items are erased.

It is impossible to erase data partially.

- (3) Contents of the trouble history

Symbol	Display			
A	Controller relation	A-1 ROM DATA FAILURE		
		A-2 MECHATRO SET ERROR		
B	Low pressure sensor	B-1 BOOM RAISE SENSOR		
		B-2 BOOM LOWER SENSOR		
		B-3 ARM OUT SENSOR		
		B-4 ARM IN SENSOR		
		B-5 BUCKET DIG SENSOR		
		B-6 BUCKET DUMP SENSOR		
		B-7 SWING (R) SENSOR		
		B-8 SWING (L) SENSOR		
		B-9 TRAVEL (R) SENSOR		
		B-10 TRAVEL (L) SENSOR		
		B-11 P1 NEGA-CON SENSOR		
		B-12 P2 NEGA-CON SENSOR		
		B-15 BACK PRESS SENSOR		
		C	High pressure sensor (Hydraulic pump)	C-1 PUMP P1 SENSOR
				C-2 PUMP P2 SENSOR
D	Proportional valve (Control valve)	D-1 P1 BYPASS PROPO-VALV		
		D-2 P2 BYPASS PROPO-VALV		
		D-3 TRAVEL PROPO-VALV		
		D-6 RECIRCULAT PROPO-VALV		
		D-8 ARM IN PROPO-VALV		
		D-10 OFFSET (L) PROPO-VALV		
E	Portional valve (Hydraulic pump)	E-1 PUMP P1 PORPO-VALV		
		E-2 PUMP P2 PORPO-VALV		
F	Solenoid valve	F-1 POWER BOOST SOLENOID		
		F-2 SWING BRAKE SOLENOID		
		F-3 TWO-SPEED SOLENOID		
G	E/G Accessory	G-1 STEP MOTOR CURRENT-NG		
		G-2 STEP MOTOR S/P.T. ERROR		
		G-3 E/G REV. SENSOR		
H	Potential relation	H-1 ACCELERATR POTENTIO		
I		I-1 RECEIVE ERROR		
		I-2 BAT. RELAY		
		MONITOR SYSTEM OK		

CHAPTER 22
HYDRAULIC SYSTEM
TABLE OF CONTENTS

A. Summary	1
B. Hydraulic Circuits and components	2-3
C. Color Coding Standard for Hydraulic Circuits	4
D. Neutral Circuit	4-5
1. Travel Circuit	6-7
2. Bucket Circuit	8-9
3. Boom Circuit	10-11
4. Boom Lower (Lower Attachment)	12-13
5. Swing Circuit (Single Pump)	14-15
6. Arm Digging Circuit (Light Load)	16-17
6. Arm Digging Circuit (Heavy Load)	18-19
6. Arm Extension (Arm Out Circuit)	20-21
7. Combined Circuit (Boom Raise and Travel Circuit)	22-23
8. Combined Arm In and Swing Circuit (Swing Priority)	24-25
11. Option Hydraulic Circuit and Componenets	26-27
12. Pilot Piping	28-32
13. Main Piping	36-42

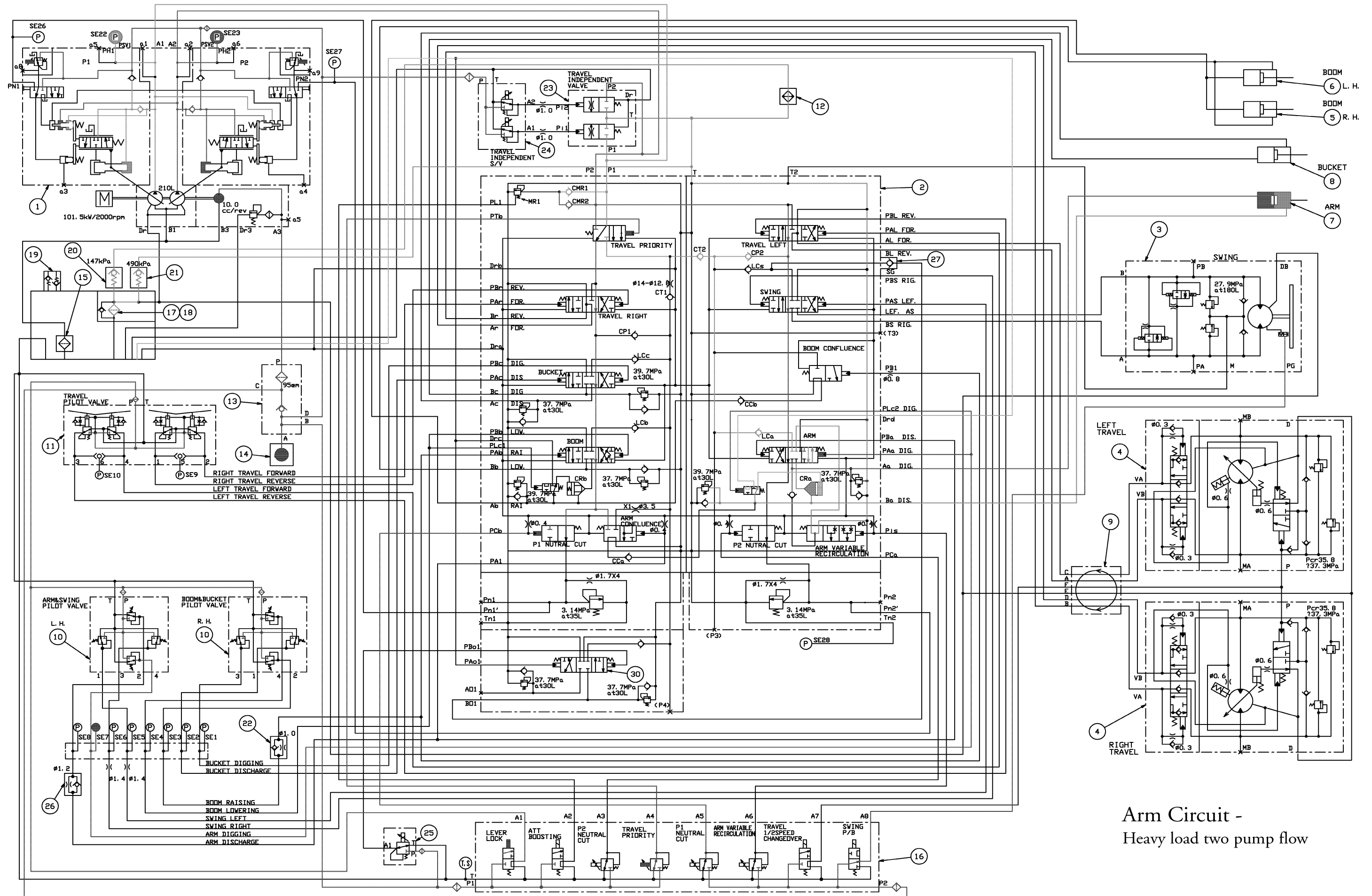

Arm Circuit -
Heavy load two pump flow

PILOT PIPING

(1) Pump delivery ; YN06H00016F1

(2) Proportional valve block lines ; YN64H00046F1 : ASIA, OCEANIA
YN64H00064F1 : E U

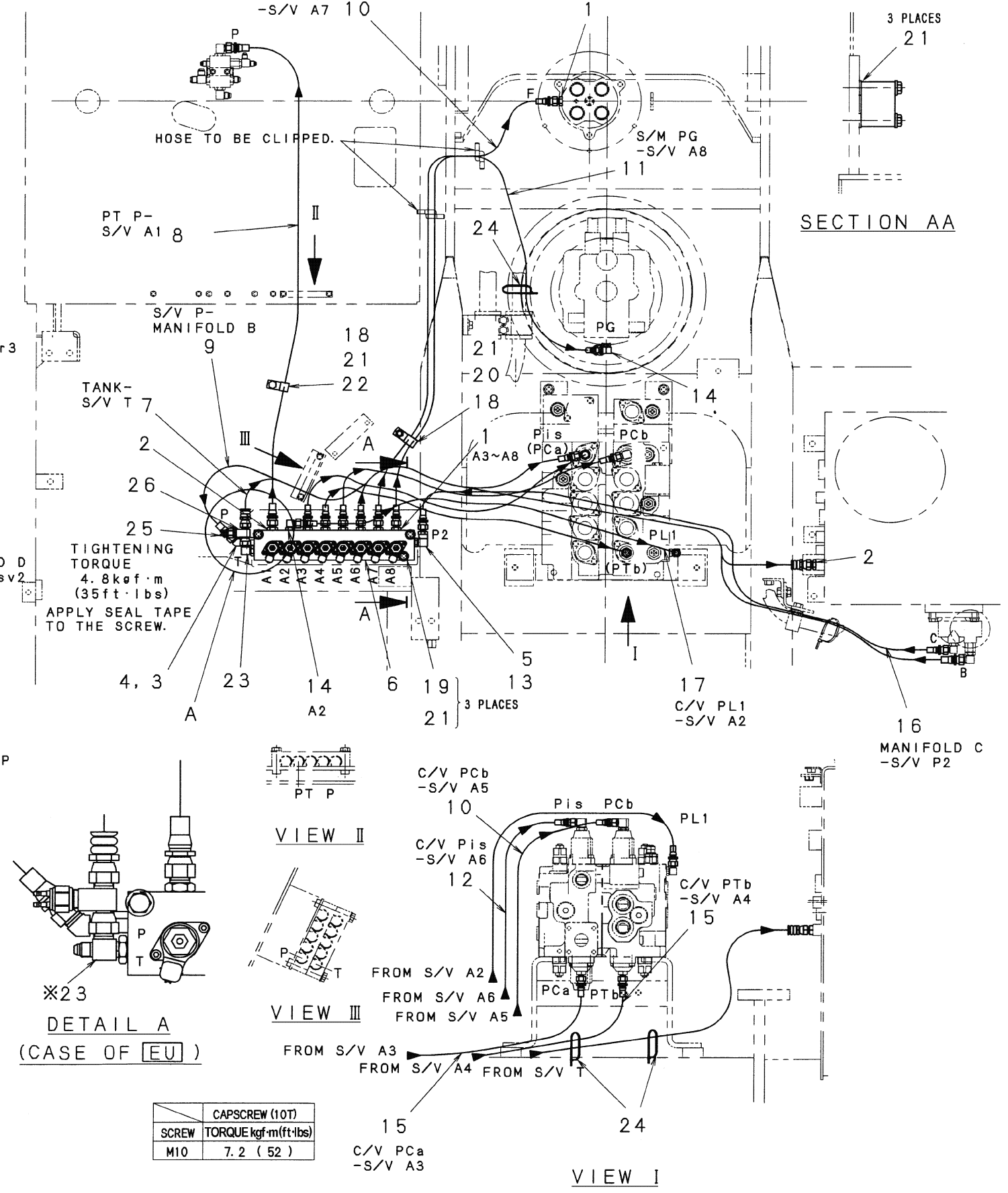
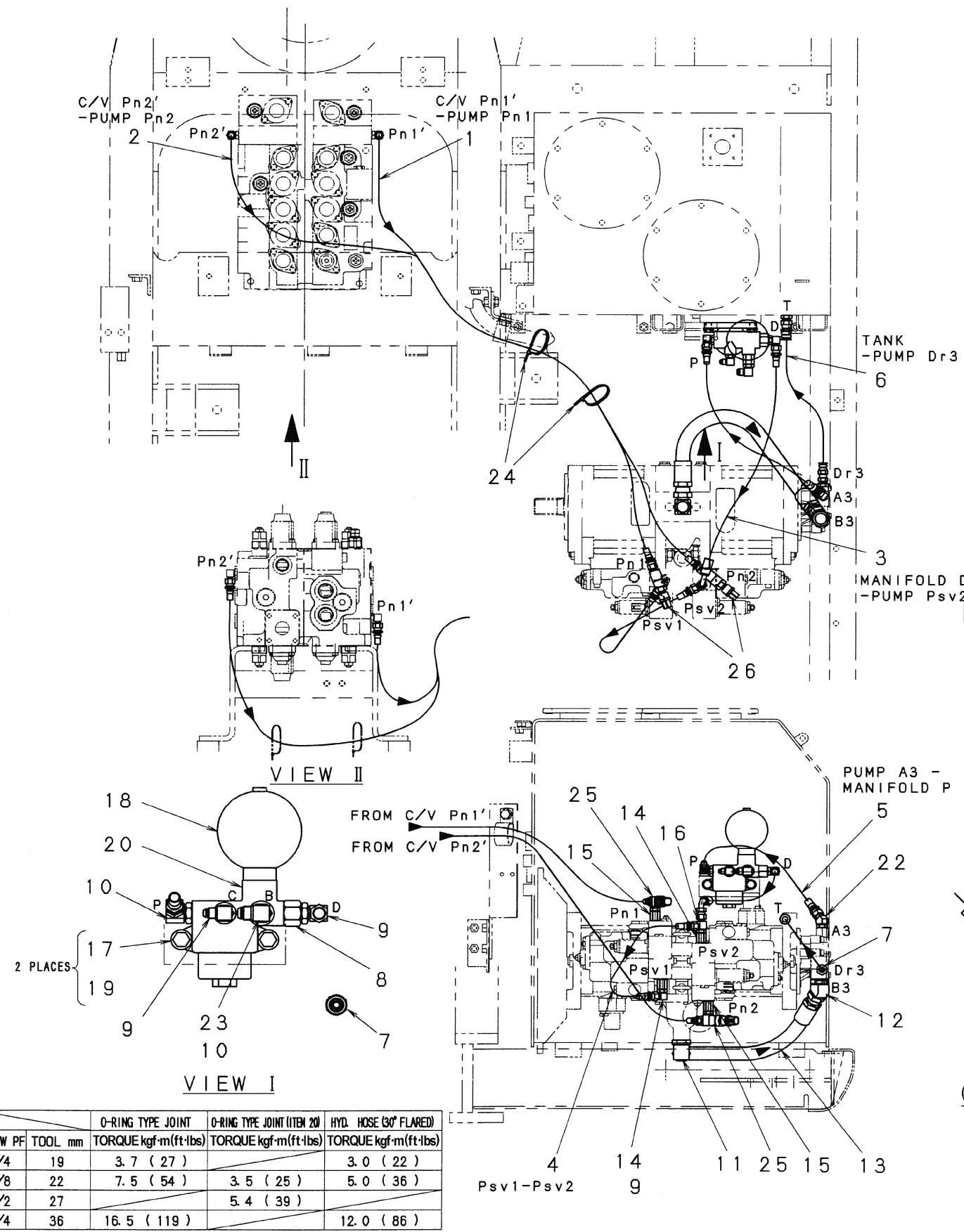

(6) Swing priority lines ; YN03H00053F1 E U

(7) Main C/V lines ; YN03H00062F1 OCEANIA
 This piping is used to add to (2) Main C/V lines ; YN03H00033F1

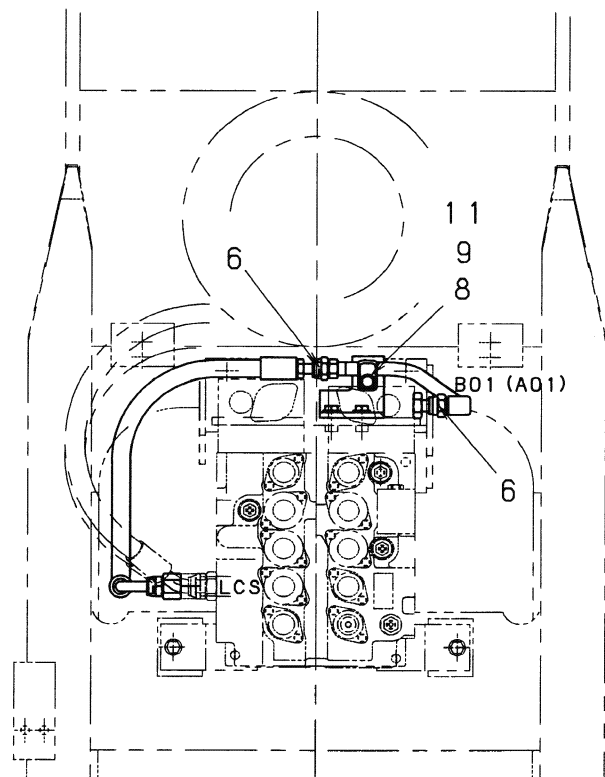
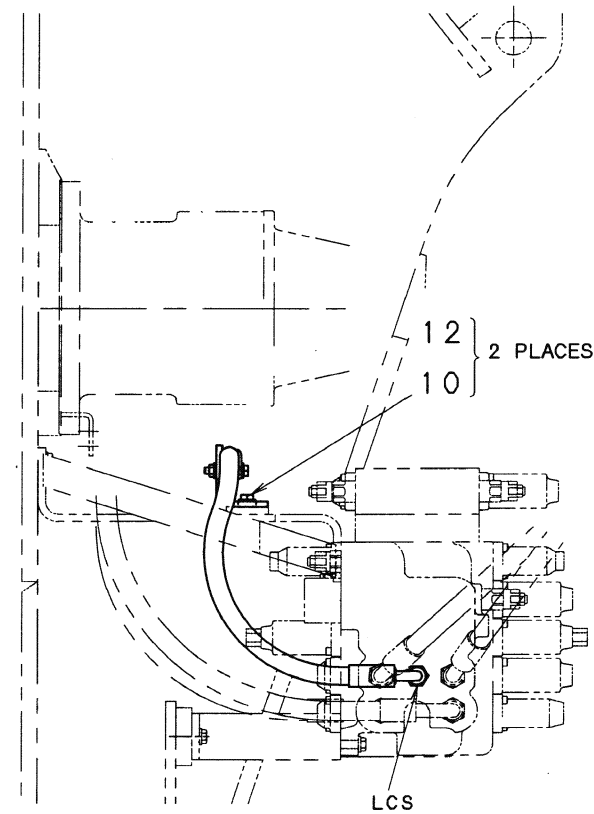
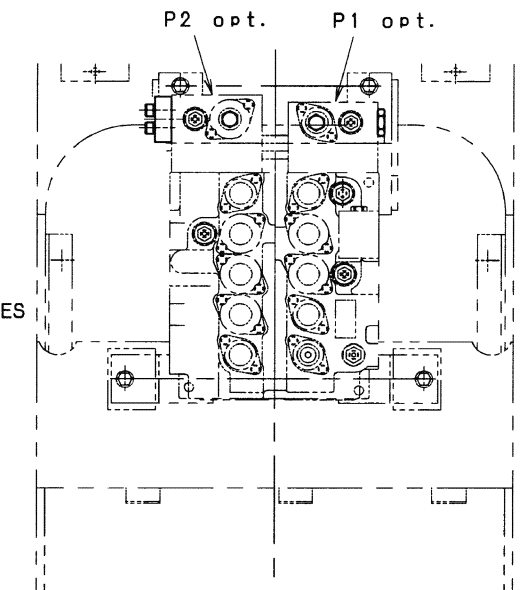
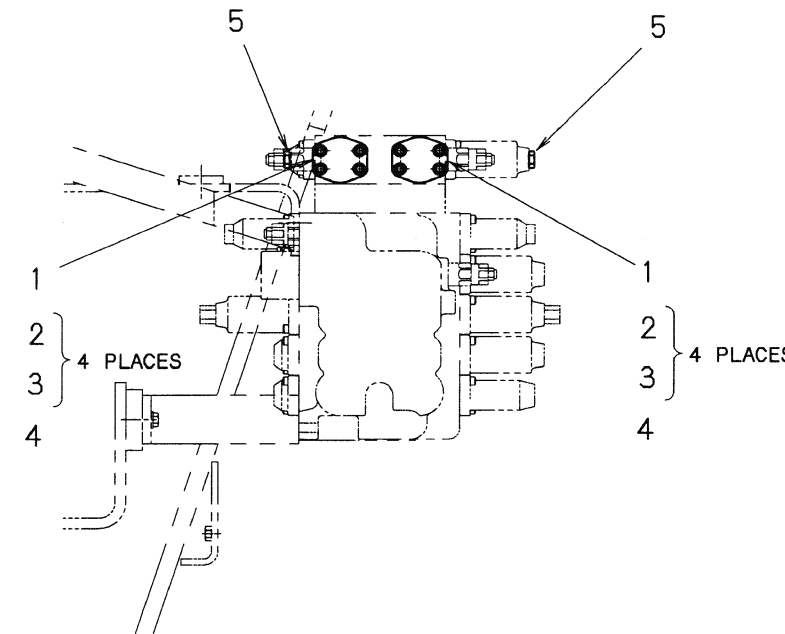
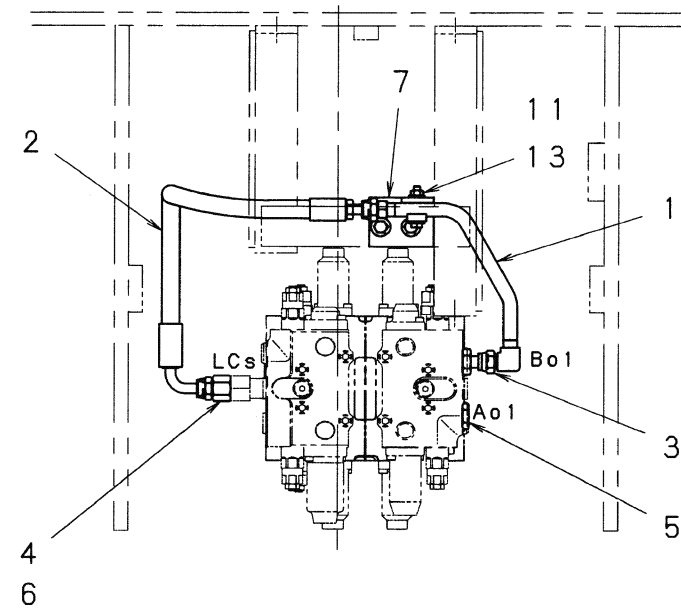

		CAPSCREW (10T)
SCREW		TORQUE kgf·m (ft·lbs)
M10		7.2 (52)
M12		12.3 (89)

			O-RING TYPE JOINT
SCREW PF	TOOL mm		TORQUE kgf·m (ft·lbs)
3/8	22		7.5 (54)
3/4	36		16.5 (119)

KAI 1.0 ELECTRIC CIRCUIT DIAGRAM (B)

C-1-MECHATRO CONTROLLER
FROM 1E-1

C-3:SW.BOX ASSY

APPLICABLE YN07-30001~
YQ07-03501~
LQ08-04501~
LL08-03001~

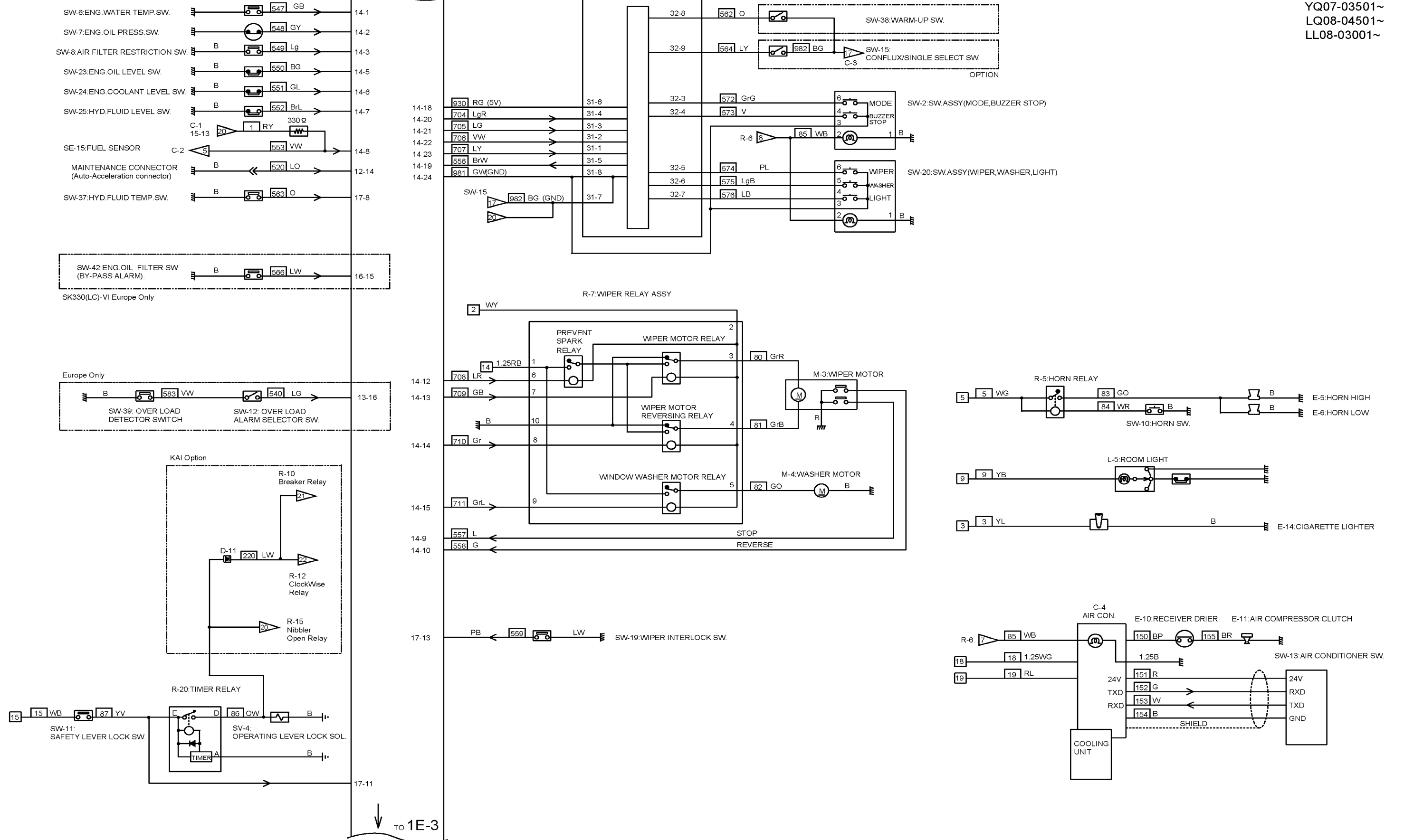

SPECIFICATIONS FOR ELECTRICAL EQUIPMENT HARNESS ASSEMBLY

YQ07U0101~

ITEM	PART NUMBER	DESCRIPTION	QTY
		HARNESS ASSY	
	YN13E00034F1	UPPER HARNESS ASSY (Floor Plate)	
A1	YN13E01167P2	HARNESS	1
A2	YN13E01156P1	HARNESS	1
A3	YN13E01166P1	HARNESS	1
A4	ZW26X08000	LOCK WASHER	1
A5	ZW16X08000	WASHER	1
A6	ZN18C08007	NUT	1
A7	YN03E01001D5	CLIP	8
A8	YN13E01190P1	GROMMET	1
A9	PY01P01043D3	CLIP	2
A10	LE13E01005P1	CABLE	1
A11	YN13E01196P1	GROMMET	2
	LB14E00003F1	CAB HARNESS ASSY	
B1	LB14E01004P1	HARNESS	1
B2	YN03E01001D5	CLIP	6
B3	ZS18C06016	CAPSCREW	1
B4	2432R233D2	CLIP	1
B5	ZW26X06000	LOCK WASHER	1
B6	ZW16X06000	WASHER	1
	YN13E00032F1	UPPER HARNESS ASSY	
C1	YN13E01155P1	HARNESS	1
C2	YN13E01053D2	CABLE	1

ITEM	PART NUMBER	DESCRIPTION	QTY
C3	YN13E01097P1	CABLE	1
C4	LB13E01020D1	CABLE	1
C5	YN13E01098P1	CABLE	1
C6	LE13E01006P1	HARNESS	1
C7	ZW26X08000	LOCK WASHER	5
C8	ZN18C08007	NUT	4
C9	ZS18C08016	CAPSCREW	1
C10	LC13E01002D1	GROMMET	1
C11	PY01P01043D3	CLIP	2
C12	2432R233D2	CLIP	2
C13	2420Z1330	GROMMET	1
C14	2427Z1594D015	TRIM	1
C15	ZW16X08000	WASHER	1
C16	2420R372D19	GROMMET	2
C17	YN03E01001D5	CLIP	3
	YN16E00009F1	ENGINE HARNESS ASSY	
D1	YN16E01016P2	HARNESS	1
D2	YN16E01014P1	BRACKET	1
D3	2432R233D2	CLIP	2
D4	2432R233D1	CLIP	1
D5	PY01P01043D3	CLIP	5
D6	2432R233D3	CLIP	7
D7	ZN18C10008	NUT	1
D8	ZN18C06005	NUT	2
D9	ZW26X10000	LOCK WASHER	1
D10	2420R608D1	SEMS-BOLT	1
D11	ZM66C06016	SEMS-BOLT	2
D12	ZM11C08016	SEMS-BOLT	3
D13	ZM22C10020	SEMS-BOLT	1
D14	ZW26X06000	LOCK WASHER	3
D15	ZW16X10000	WASHER	2
D17	ZW26X08000	LOCK WASHER	1
D18	YN16E01012P1	BRACKET	1
D19	ZM22C10040	SEMS-BOLT	2
D20	2418T26637D1	SPACER	2
D21	ZS18C08016	CAPSCREW	1
D22	ZS18C06010	CAPSCREW	1
D23	ZW16X06000	WASHER	1

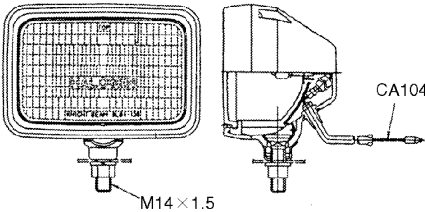
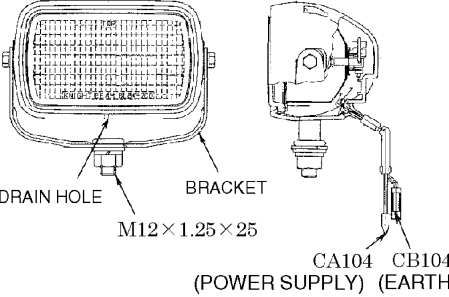
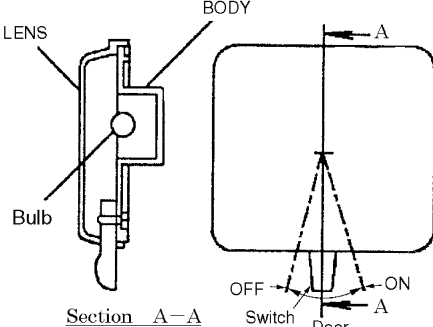
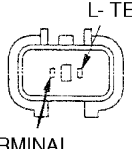
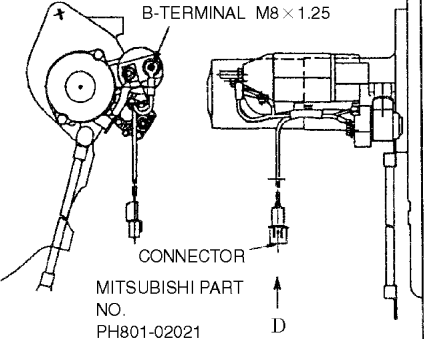
File No. Name of part Part No. Use Applicable Machine	Specification	Description						
<p>L-1</p> <p>Light</p> <p>YW80S00001F1</p> <p>Boom work light (left)</p> <p>YN23301~, YQ02801~ YX01001~, YV00101~ YY00101~, YF00101~ YN07-30001~, YQ07-03501~ LQ08-04501~, LL08-03001~</p>	<table border="1"> <tr> <td>Type</td> <td>BL84-130</td> </tr> <tr> <td>Bulb</td> <td>24V,70W</td> </tr> </table>	Type	BL84-130	Bulb	24V,70W			
Type	BL84-130							
Bulb	24V,70W							
<p>L-2,7,8,9</p> <p>Light</p> <p>YN80S00010F2</p> <p>Deck work light (Right)</p> <p>OPT: Cab work light (L&R) OPT: Boom cylinder work light</p> <p>YW07901~, LP13601~ YN23301~, YQ02801~ LQ03701~, YF00101~ YN07-30001~, YQ07-03501~ LQ08-04501~, LL08-03001~</p>	<table border="1"> <tr> <td>Type</td> <td>BL84-200</td> </tr> <tr> <td>Bulb</td> <td>DC 24V,70W</td> </tr> <tr> <td>Effective area of lens</td> <td>71cm²</td> </tr> </table>	Type	BL84-200	Bulb	DC 24V,70W	Effective area of lens	71cm ²	
Type	BL84-200							
Bulb	DC 24V,70W							
Effective area of lens	71cm ²							
<p>L-5</p> <p>Light</p> <p>YT80S00001P1</p> <p>Room light</p> <p>YW06501~ LP11001~, YP02301~ YN18001~, YQ02301~ LQ03301~, LL02301~ YN07-30001~, YQ07-03501~ LQ08-04501~, LL08-03001~ LC06-05501~, YC06-02501~</p>	<table border="1"> <tr> <td>Bulb</td> <td>24V,5W</td> </tr> </table> <p>Note) Equivalent to 2456Z322F1</p>	Bulb	24V,5W					
Bulb	24V,5W							
<p>M-1</p> <p>Motor</p> <p>ME049303</p> <p>Starter motor</p> <p>YF00101~ YN07-30001~, YQ07-03501~ LQ08-04501~, LL08-03001~ LC06-05501~, YC06-02501~</p>	<table border="1"> <tr> <td>Rated output</td> <td>DC24V, 5.0kW</td> </tr> <tr> <td>MITSUBISHI part No.</td> <td>ME049303</td> </tr> </table>  <p>VEIW D</p>	Rated output	DC24V, 5.0kW	MITSUBISHI part No.	ME049303			
Rated output	DC24V, 5.0kW							
MITSUBISHI part No.	ME049303							

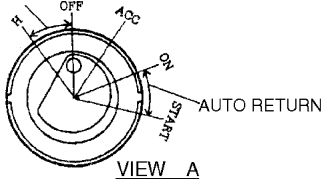
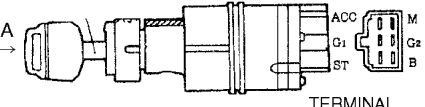
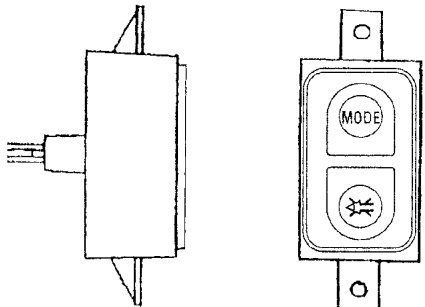
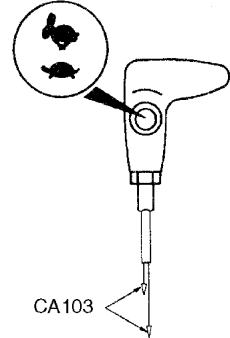
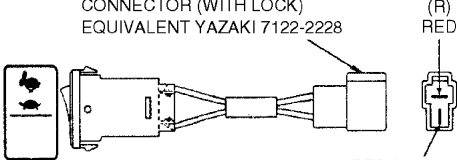
File No. Name of part Part No. Use Applicable Machine	Specification	Description																																																
<p>SW-1</p> <p>Switch</p> <p>YN50S00002F1</p> <p>Starter switch</p> <p>YW06501~ LP11001~ YP02301~ YN18001~ YQ02301~ LQ03301~ LL02301~ YT00101~ YR04001~ YX00101~ YV00101~ YY00101~ YF00101~ YN07-30001~ YQ07-03501~ LQ08-04501~ LL08-03001~ LC06-05501~ YC06-02501~</p>	<table border="1"> <tr> <td>P</td> <td>T</td> <td>B</td> <td>G₁</td> <td>G₂</td> <td>ACC</td> <td>M</td> <td>ST</td> </tr> <tr> <td>H</td> <td></td> <td>○</td> <td>○</td> <td></td> <td></td> <td></td> <td></td> </tr> <tr> <td>OFF</td> <td></td> <td></td> <td></td> <td></td> <td></td> <td></td> <td></td> </tr> <tr> <td>ACC</td> <td></td> <td>○</td> <td></td> <td></td> <td>○</td> <td></td> <td></td> </tr> <tr> <td>ON</td> <td></td> <td>○</td> <td></td> <td></td> <td>○</td> <td>○</td> <td></td> </tr> <tr> <td>START</td> <td></td> <td>○</td> <td></td> <td>○</td> <td></td> <td>○</td> <td>○</td> </tr> </table>	P	T	B	G ₁	G ₂	ACC	M	ST	H		○	○					OFF								ACC		○			○			ON		○			○	○		START		○		○		○	○	<p>AUTO RETURN</p>  <p>VIEW A</p> <p>"K250" STAMPED</p>  <p>TERMINAL ARRANGEMENT</p>
P	T	B	G ₁	G ₂	ACC	M	ST																																											
H		○	○																																															
OFF																																																		
ACC		○			○																																													
ON		○			○	○																																												
START		○		○		○	○																																											
<p>SW-2</p> <p>Switch</p> <p>YN50E00002F1</p> <p>Mode, buzzer stop</p> <p>YN07-30001~ YQ07-03501~ LQ08-04501~ LL08-03001~ LC06-05501~ YC06-02501~</p>	<table border="1"> <tr> <td>Type</td> <td>Sheet type, with back light</td> </tr> </table>	Type	Sheet type, with back light																																															
Type	Sheet type, with back light																																																	
<p>SW-3</p> <p>Switch</p> <p>YN03M01039P1 (Right travel grip)</p> <p>Travel 1,2-speed</p> <p>YW06501~ LP11001~ YP02301~ YN18001~ YQ02301~ LQ03301~ LL02301~ YN07-30001~ YQ07-03501~ LQ08-04501~ LL08-03001~</p>	<table border="1"> <tr> <td>Type</td> <td>Buried in right travel lever</td> </tr> </table>	Type	Buried in right travel lever	<p>MARKS ON SWITCH PORTION</p> 																																														
Type	Buried in right travel lever																																																	
<p>SW-3</p> <p>Switch</p> <p>2479U1224F4</p> <p>Travel 1,2-speed</p> <p>YN07-30001~ YQ07-03501~ LQ08-04501~ LL08-03001~ LC06-05501~ YC06-02501~</p>	<table border="1"> <tr> <td>Type</td> <td>Single-pole single-throw momentary</td> </tr> <tr> <td>Rated voltage</td> <td>DC 24V</td> </tr> <tr> <td>Insulation resistance</td> <td>More than 1MΩ / DC500V megger</td> </tr> </table> <p>TERMINAL CONNECTOR</p> <table border="1"> <tr> <td>Terminal Position</td> <td>R</td> <td>RW</td> <td></td> </tr> <tr> <td>OFF</td> <td></td> <td></td> <td></td> </tr> <tr> <td>ON</td> <td>○</td> <td>○</td> <td></td> </tr> </table>	Type	Single-pole single-throw momentary	Rated voltage	DC 24V	Insulation resistance	More than 1MΩ / DC500V megger	Terminal Position	R	RW		OFF				ON	○	○		<p>CONNECTOR (WITH LOCK) EQUIVALENT YAZAKI 7122-2228</p>  <p>RED / WHITE</p> <p>(R) RED</p>																														
Type	Single-pole single-throw momentary																																																	
Rated voltage	DC 24V																																																	
Insulation resistance	More than 1MΩ / DC500V megger																																																	
Terminal Position	R	RW																																																
OFF																																																		
ON	○	○																																																

2.2 EU

Group	Code	NAME	PART No.	Group	Code	NAME	PART No.	Group	Code	NAME	PART No.	
POWER	B-1	Battery (170F51) For EU	2484U175	PROPORTIONAL VALVE	PSV-A	Arm variable recirculation proportional valve	YN35V00022F1	SOLENOID	SV-1	Swing parking SOL	YN35V00022F1	
					PSV-B	P2 bypass cut proportional valve	↑			SV-2	ATT power boost pressure SOL	↑
CONTROLLER	C-1	Mechatro controller E215	YN22E00069F2		PSV-C	Travel straight proportional valve	↑			SV-3	Travel 1-2 speed SOL	↑
	C-1	Mechatro controller	LQ22E00029F2		PSV-D	P1 bypass cut proportional valve	↑			SV-4	Safety lock lever SOL	↑
	C-2	Gauge cluster	YN59E00001F2		PSV-P1	P1 Pump proportional valve	YN35V00018F2			SV-5		
	C-3	Switch box assy	YN50E00004F1		PSV-P2	P2 Pump proportional valve	(YN10V00007F1 : Pump)			SV-11	Extra SOL	YN35V00010F1
	C-4	Air conditioner amplifier	YT20M00004S036		PSV-1					SV-12		
					PSV-2							
					PSV-H	Swing priority proportional valve	YM35V00001F1					
DIODE	D-1	Diode	YN02D01001P1		R-1	Battery relay	YT24S00001F1					
	D-2	Diode	↑		R-2	Starter relay	ME701597					
	D-3	Diode	2475R132		R-3	Glow relay	ME072890					
	D-4	Diode	↑	R-4	Safety relay	ME077148						
	D-5	(Diode)	YN02D01001P1	R-5	Horn relay	YR24S00002P1						
	D-6	(Diode)	↑	R-6	Work light relay	↑		SW-1	Key switch	YN50S00002F1		
	D-9	Diode	↑	R-7	Wiper relay assy	YT24E00001F1		SW-2	Switch assy (mode, buzzer stop)	YN50E00002F1		
	D-10	(Diode)	↑	R-9	Work light relay (Cab working light relay)	YR24S00002P1		SW-3	Travel1-2 speed switch	2479U1224F4		
	D-11	(Diode)	↑	R-10				SW-4	Swing parking release switch	YX50E00002F1		
				R-11	Work light relay (Cab working light relay)	YR24S00002P1		SW-5	KPSS release switch	YN50S01003P1		
	ELECTRIC FITTINGS	E-1	Fuse box	YN73E00007F1	R-12				SW-6	Engine water temperature switch	ME039860	
E-2		Alternator E215	ME088887	R-13				SW-7	Engine oil pressure switch	MC840219		
E-2		Alternator	ME150693	R-14				SW-8	Air filter clogging switch	YR11P00008S005		
E-3		Hour meter	YN58S00004P1	R-15				SW-9	Swing flasher switch	2479U1190F9		
E-4		Resistor	LC22E01001D1	R-16				SW-10	Horn switch	YN50E00007P1		
E-5		Horn (High)	2479U1009F1	R-19	Flasher relay	YY24S00001P1		SW-11	Safety lock lever switch	YN50S01001P1		
E-6		Horn (Low)	2479U1009F2	R-20	Timer relay	YN25S00001P1		SW-12	Over load alarm select switch	2479U1190F33		
E-7		Tuner AM/FM	Locally procured parts					SW-13	Air conditioner switch (Air-con panel) (C° ↔ F°)	YN20M01299P1		
E-8		Speaker LH	YN54S00006P1					SW-14				
E-9		Speaker RH	↑	SE-1	Pressure sensor : Bucket digging	LC52S00001P2		SW-15	(Single/conflux flow select switch)	2479U1190F30		
E-10		Receiver dryer	YT54S00002P1	SE-2	Pressure sensor : Bucket dump	↑		SW-16	Engine room light switch	YT50S00005P1		
E-11		A/C compressor	LC91V00001F1	SE-3	Pressure sensor : Boom up	↑		SW-19	Wiper inter lock switch	YN50E00006P1		
E-12				SE-4	Pressure sensor : Boom down	↑		SW-20	Switch assy (wiper, washer, work light)	YN50E00003F1		
E-14		Cigarette lighter	2421R180F1	SE-5	Pressure sensor : Swing left	↑		SW-21	ATT power boost switch	YN50E00007P1		
E-22	Converter (DC24V→12V)	YN77S00005F1	SE-6	Pressure sensor : Swing right	↑		SW-22					
E-23	Socket (For KAI, EU)	YN81S00001P1	SE-7	Pressure sensor : Arm in	↑		SW-23	Engine oil level switch	MC867765			
E-A	Antenna	YT54S00001P1	SE-8	Pressure sensor : Arm out	↑		SW-24	Engine coolant level switch	2427U203S6			
LIGHT	L-1	Boom work light LH	YW80S00001F1	SE-9	Pressure sensor : Travel right	↑		SW-25	Hydraulic oil level switch	YN52S00023P1		
	L-2	Deck work light RH	YN80S00010F2	SE-10	Pressure sensor : Travel left	↑		SW-26	Work light switch (Cab working light)	2479U1190F1		
	L-3	Swing flasher & work light unit LH	YN80S00015F3	SE-11	(Pressure sensor : P2 OPT.)	LC52S00001P2		SW-27				
	L-4	Swing flasher & work light unit RH	YN80S00015F4	SE-12				SW-28				
	L-5	Room light	YT80S00001P1	SE-13	Engine speed sensor	MC849577		SW-29				
	L-6	Boom work light RH	YW80S00001F1	SE-14	Engine water temp. sensor (Thermo sensor)	YT52S00001P1		SW-30				
	L-7	(Cab work light LH)	YN80S00010F2	SE-15	Fuel sensor	2489U275		SW-31				
	L-8	(Cab work light RH)	↑	SE-16	Accel potentiometer	YN52S00009P1		SW-32				
	L-11	Engine room light (Bulb 4056Z19D1 24V 10W)	4056R4F1	SE-18				SW-33				
	L-12			SE-20	(Pressure sensor : P1 OPT.)	LC52S00001P2		SW-34				
	L-13			SE-21				SW-35	Heavy lift switch	2479U1190F13		
				SE-22	Pressure sensor : P1 pump	LC52S00002P1		SW-36				
				SE-23	Pressure sensor : P2 pump	↑		SW-37	Hydraulic oil temperature switch	2479R2348		
MOTOR	M-1	Starter motor	ME049303	SE-24				SW-38	Warm-up switch	2479U1190F31		
	M-2	Governor motor	YT20S00002F3	SE-25				SW-39	Over load detect switch	Locally installed parts		
	M-3	Wiper motor	YT53C00004P1	SE-26	Pressure sensor : P1 negative control	YN52S00016P1		SW-40	Rotary light switch	YR24S00002P1		
	M-4	Washer motor (Tank Assy : 24100U157F1)	2427U900	SE-27	Pressure sensor : P2 negative control	↑		SW-42	Engine oil filter switch (Bypass valve)	ME084614		
	M-11	Fuel pump	YT22P00001F4	SE-28	Pressure sensor : Back pressure	LC52S00001P2		SW-47	Extra & Breaker switch	2479U1190F21		

3.4 INSTRUMENT PANEL ASSY ASIA, OCEANIA

INSTRUMENT PANEL ASSY	With swing flasher Radioless	YN17M00010FD							
	With swing flasher and radio	YN17M00010FJ							
	OCEANIA	YN17M00010FK							
	THAILAND	YN17M00010FN							
	INDONESIA	YN17M00010FP							
ITEM	NAME	PART No.	Q'TY				REMARKS		
1	COVER ASSY	YN17M01051F1	1	1	1	1			
1-2	SWITCH ASSY	YN50E00003F1	1	1	1	1	Wiper, washer, work light switch		
2	COVER ASSY	YN17M01052F1	1	1	1	1			
2-2	POTENTIOMETER	YN52S00009P1	1	1	1	1			
2-3	KEY SWITCH	YN52S00002F1	1	1	1	1			
7	SPEAKER	YN54S00006P1	—	2	2	—	24V		
8	TUNER	LC54S00001P1	—	1	—	—	AM / FM		
17	CIGARETTE LIGHTER	2421R180F1	1	1	1	1			
20	HOUR METER	YN58S00004P1	1	1	1	1			
23	CABLE	YN17M01072P1	—	1	1	—	For tuner		
36	SWITCH ASSY	YN50E00003F1	1	1	1	1			
41	SWITCH ASSY	YN50E00002F1	1	1	1	1	Buzzer stop, work mode switch		
43	SWITCH	2479U1190F31	1	1	1	1	Warm up sw.		
44	SWITCH	2479U1190F9	1	1	1	1	Swing flasher		
45	GAUGE CLUSTER ASSY	YN59E00002F2	1	1	1	—			
48	TUNER	YN54S00013P1	—	—	1	—			
51	GAUGE CLUSTER ASSY	YN59E00002F3	—	—	1	—	Thailand		
52	GAUGE CLUSTER ASSY	YN59E00002F4	—	—	1	—	Indonesia		

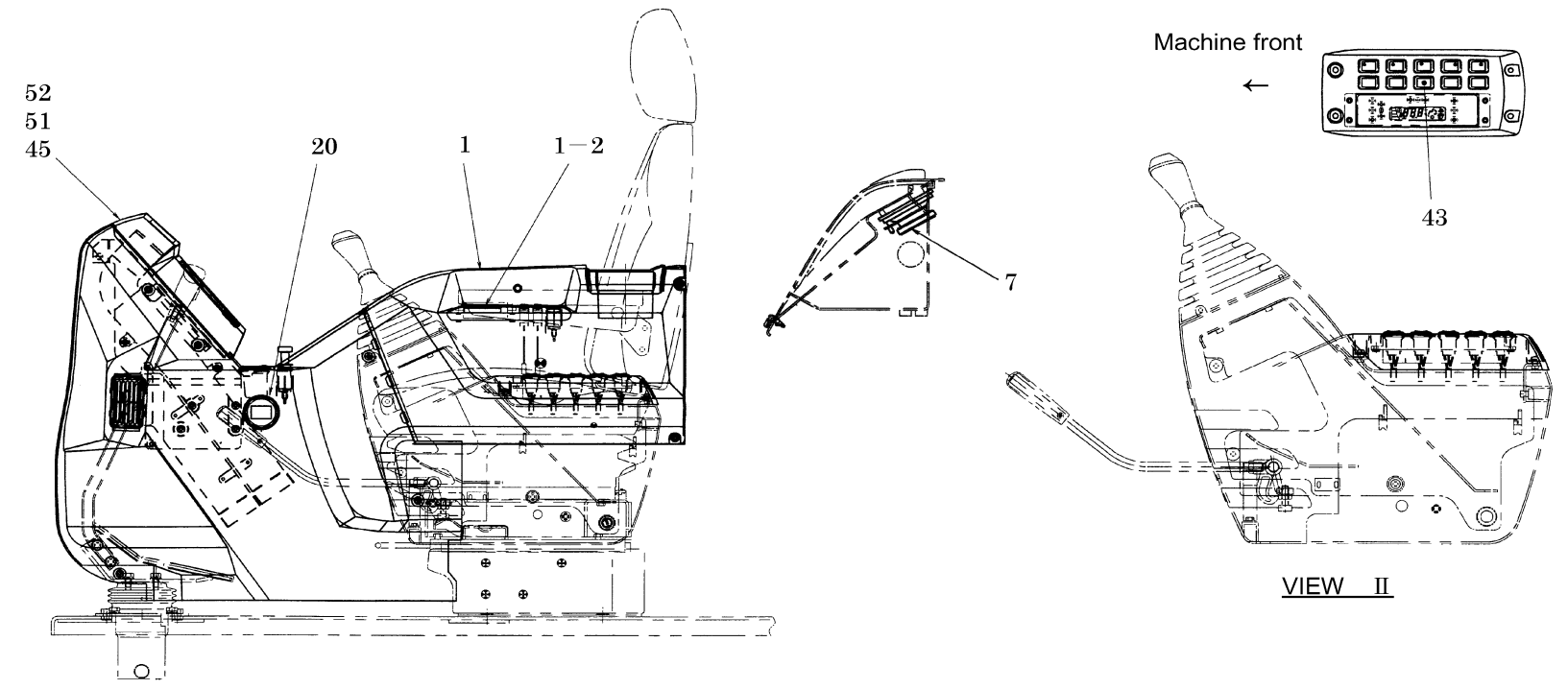
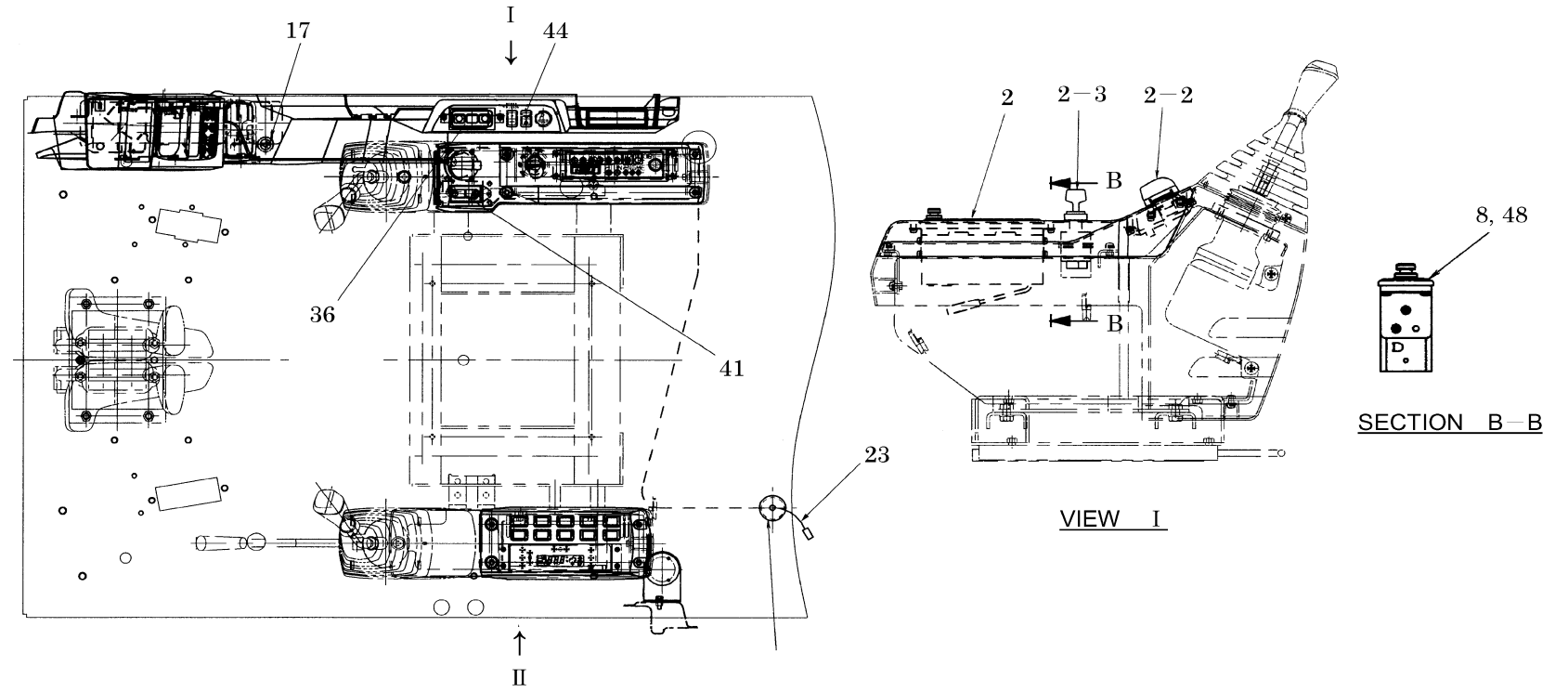

3.4.23 CABLE (FOR ANTENNA) YN17M01072P1

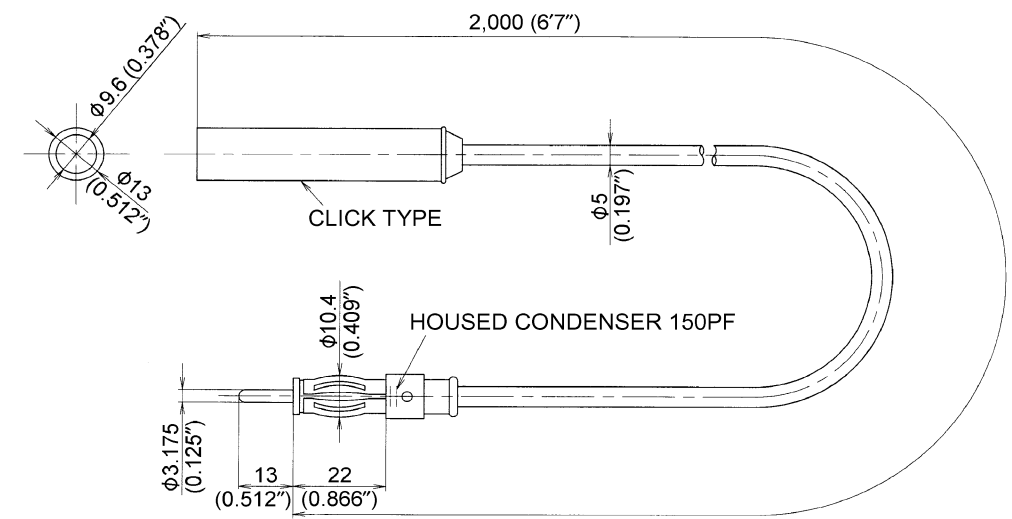
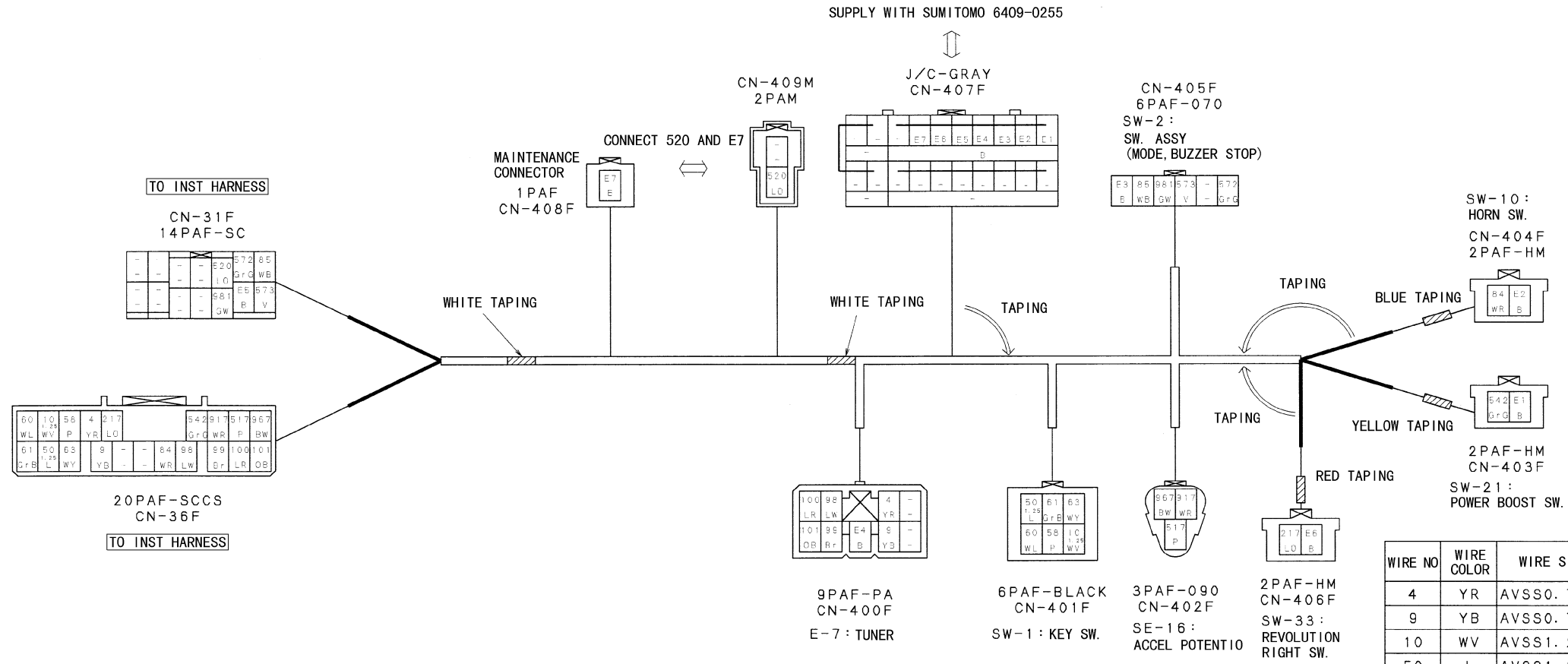

Fig.5A Instrument panel assy

3.8.2 INSTRUMENT PANEL RH HARNESS : YN13E01132P1, ASIA, OCEANIA



CONNECTORS SELECTION TABLE

CONNECTOR NAME (PIN NUM.)	MANUFUC.	PART. NUMBER	
		HOUSING	TERMINAL
20PAF-SCCS	AMP	316010-2	175268-1
			175269-1
14PAF-SC	AMP	178689-2	175266-2
			175269-1
6PAF-070	AMP	174923-1	173631-1
			173631-2
3PAF-090	SUMITOMO	6180-3241	1500-0110
2PAF-HM	SUMITOMO	6090-1001	8240-4422
6PAF-BLACK	YAZAKI	7123-2262-30	7116-2090
9PAF-PA	YAZAKI	7119-3090	7116-1050
J/C-GRAY	SUMITOMO	6400-0081	8240-4422
		6409-0255	
1PAF	YAZAKI	7123-2215	7116-2090
2PAM	YAZAKI	7122-2228	7114-2020

WIRE NO	WIRE COLOR	WIRE SIZE	FROM	CONNECTION	TO	FUNCTION
4	YR	AVSS0.75sq	CN-400F	—————	CN-36F	TUNER ← FUSE BOX
9	YB	AVSS0.75sq	CN-400F	—————	CN-36F	TUNER ← FUSE BOX
10	WV	AVSS1.25sq	CN-401F	—————	CN-36F	KEY SW. ← FUSE BOX
50	L	AVSS1.25sq	CN-401F	—————	CN-36F	KEY SW. → FUSE BOX
58	P	AVSS0.75sq	CN-401F	—————	CN-36F	KEY SW. → GLOW RELAY
60	WL	AVSS0.75sq	CN-401F	—————	CN-36F	KEY SW. → DIODE
61	GrB	AVSS0.75sq	CN-401F	—————	CN-36F	KEY SW. → DIODE
63	WY	AVSS0.75sq	CN-401F	—————	CN-36F	KEY SW. → STARTER RELAY
84	WR	AVSS0.75sq	CN-404F	—————	CN-36F	HORN SW. ← HORN RELAY
85	WB	AVSS0.75sq	CN-405F	—————	CN-31F	SW ASSY (MODE, BUZZER STOP) ← WORK LIGHT RELAY
98	LW	AVSS0.75sq	CN-400F	—————	CN-36F	TUNER → SPEAKER LEFT
99	Br	AVSS0.75sq	CN-400F	—————	CN-36F	TUNER ← SPEAKER LEFT
100	LR	AVSS0.75sq	CN-400F	—————	CN-36F	TUNER → SPEAKER RIGHT
101	OB	AVSS0.75sq	CN-400F	—————	CN-36F	TUNER ← SPEAKER RIGHT
217	LO	AVSS0.75sq	CN-406F	—————	CN-36F	REVOLUTION RIGHT SW. → REVOLUTION RIGHT RELAY
517	P	AVSS0.75sq	CN-402F	—————	CN-36F	ACCEL POTENTIOMETER → MECHATRONIC CONTROLLER
520	LO	AVSS0.75sq	CN-409F	—————	CN-31F	CONNECTOR FOR MAINTENANCE ← MECHATRONIC CONTROLLER
542	GrG	AVSS0.75sq	CN-403F	—————	CN-36F	POWER BOOST SW → MECHATRONIC CONTROLLER
572	GrG	AVSS0.75sq	CN-31F	—————	CN-405F	SW BOX ASSY → SW ASSY (MODE, BUZZER STOP)
573	V	AVSS0.75sq	CN-31F	—————	CN-405F	SW BOX ASSY → SW ASSY (MODE, BUZZER STOP)
917	WR	AVSS0.75sq	CN-402F	—————	CN-36F	ACCEL POTENTIOMETER ← MECHATRONIC CONTROLLER
967	BW	AVSS0.75sq	CN-402F	—————	CN-36F	ACCEL POTENTIOMETER → MECHATRONIC CONTROLLER
981	GW	AVSS0.75sq	CN-405F	—————	CN-31F	SW ASSY (MODE, BUZZER STOP) → MECHATRONIC CONTROLLER
E1	B	AVSS0.75sq	CN-403F	—————	CN-407F	POWER BOOST SW → J/C-GRAY
E2	B	AVSS0.75sq	CN-404F	—————	CN-407F	HORN SW. → J/C-GRAY
E3	B	AVSS0.75sq	CN-405F	—————	CN-407F	SW ASSY (MODE, BUZZER STOP) → J/C-GRAY
E4	B	AVSS0.75sq	CN-400F	—————	CN-407F	TUNER → J/C-GRAY
E5	B	AVSS0.75sq	CN-31F	—————	CN-407F	EARTH ← J/C-GRAY
E6	B	AVSS0.75sq	CN-406F	—————	CN-407F	REVOLUTION RIGHT SW. ← J/C-GRAY
E7	B	AVSS0.75sq	CN-408F	—————	CN-407F	CONNECTOR FOR MAINTENANCE → J/C-GRAY

Fig.1A Instrument panel right harness

3.16 CAB LIGHT INSTAL

CAB LIGHT INSTAL		YN80E00018F7			EU	
		YN80E00018F9			THAILAND	
		YN80E00018FA			INDONESIA	
ITEM	NAME	PART No.	Q'TY		REMARKS	
6	HARNESS	YN02C01760P1	-	2	2	
7	SWITCH	2479U1190F1	-	1	-	Travel 1-2 speed
11	RELAY	YR24S00002P1	-	1	-	
13	HARNESS	YN02C01928P1	1	-	-	RH
15	HARNESS	YN02C01973P1	1	-	-	LH
16	LIGHT	YT80S00002F2	-	1	-	

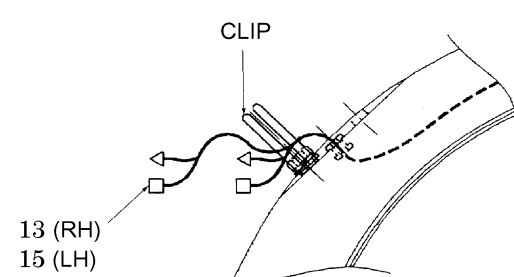
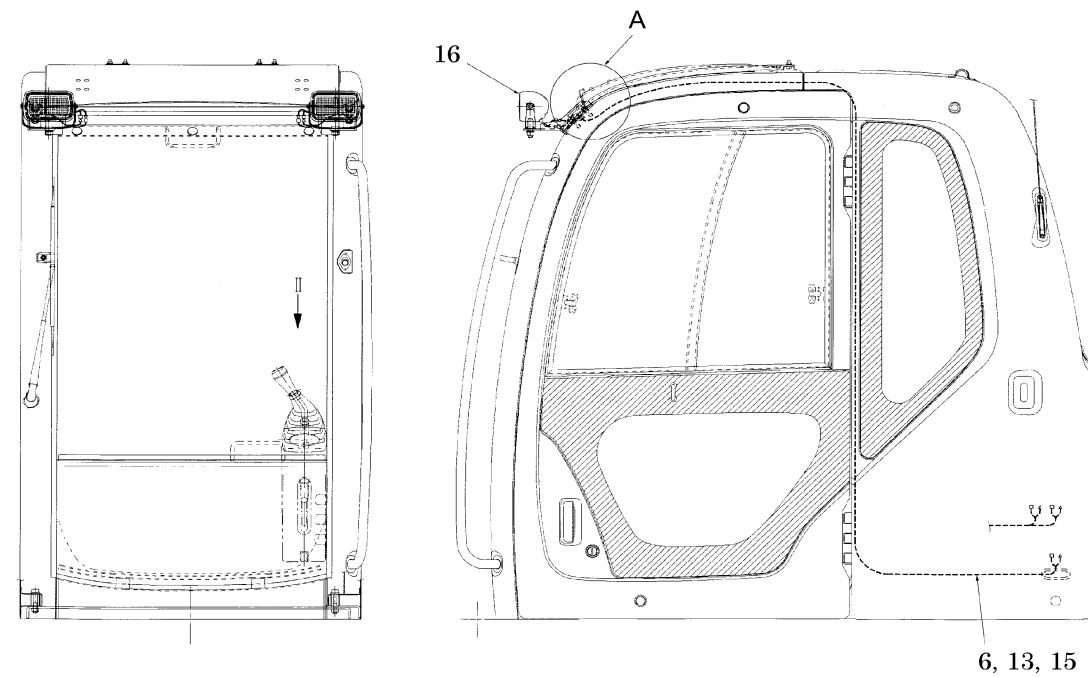

DETAIL OF A

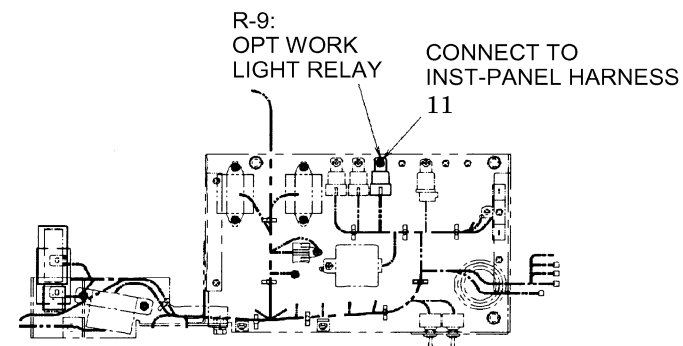

DETAIL OF LOWER STAGE OF CONTROLLER ASSY

Fig.32 Callight instal

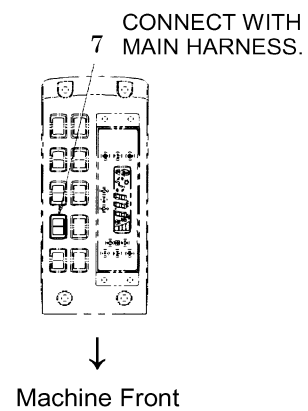

Machine Front

3.16.6 HARNESS ; YN02C01760P1, ASIA

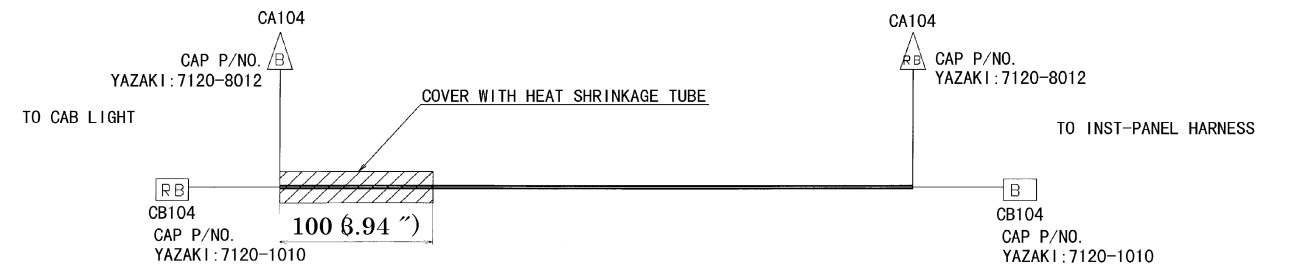

Fig.33A Harness

3.16.13 CAB LIGHT HARNESS (RH) ; YN02C01928P1, EU

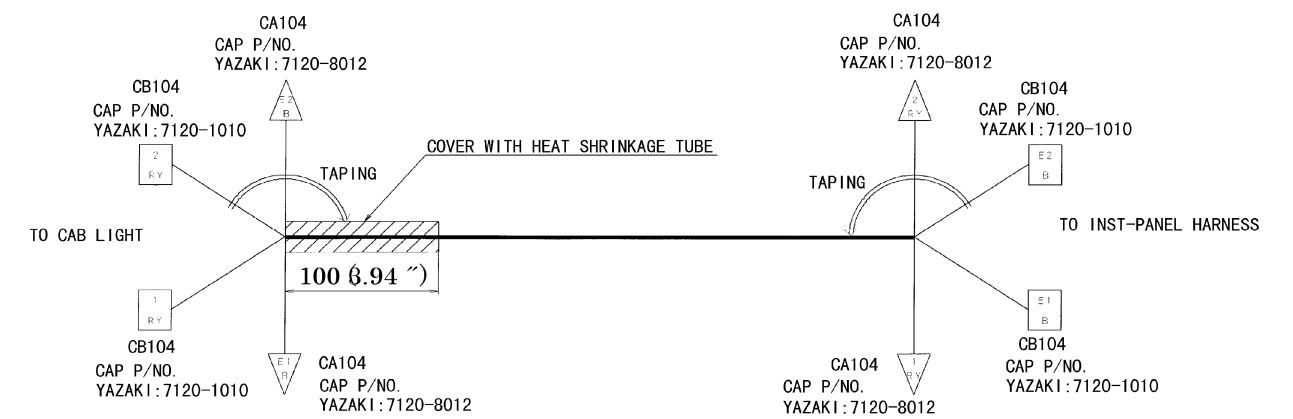

Fig.33E Callight harness (RH)

3.16.15 CAB LIGHT HARNESS (LH) ; YN02C01973P1, EU

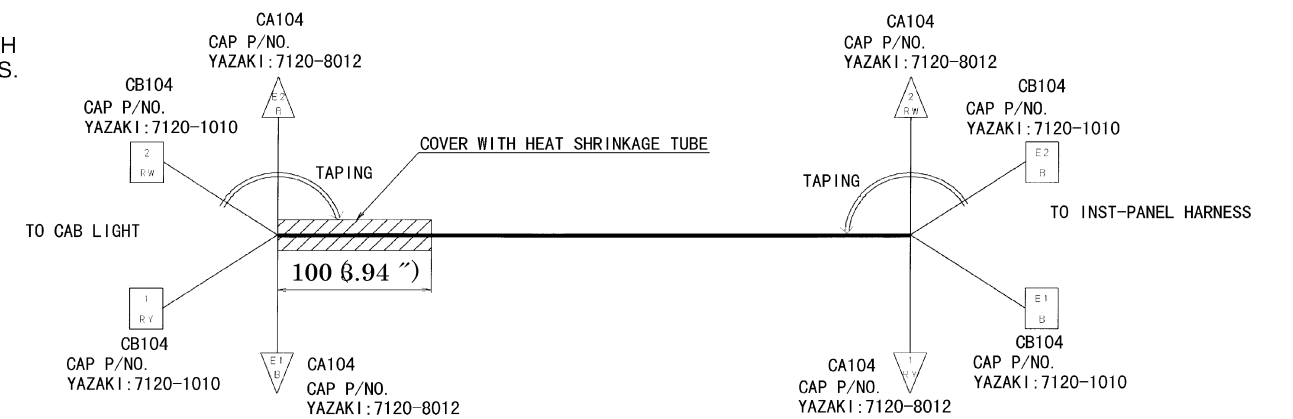

Fig.34E Callight harness (LH)

(2) Hydraulic circuit diagram

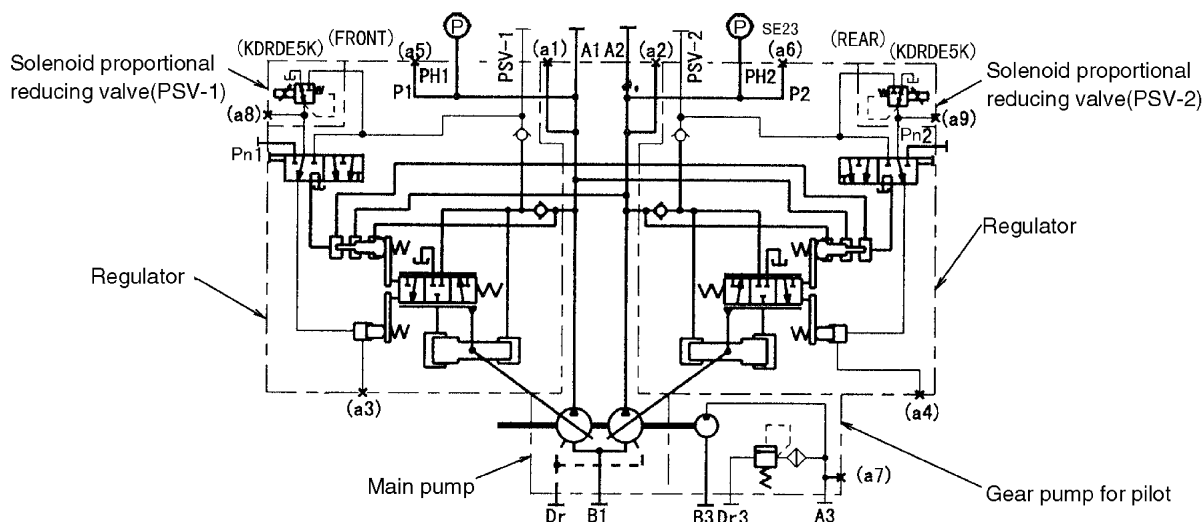

Fig. 1-2 Hydraulic circuit diagram of pump

(3) Specification

Table 1-2

Item		Main pump	Gear pump for pilot
Parts No.	Pump assy	YN10V00007F1	—
	Single pump	YN10V00013F1	YN10V00014F1
Pump model		K3V112DT-1RAR-9TIL	ZX10LGRZ2-06D
Max. displacement capacity	cm ³ /rev	105×2	10
Swing speed	Rated	rpm	←
	Hi idle	(Clockwise)	←
Pressure	Rated	kgf/cm ² (psi)	50(710)
	ATT boost pressure		
Max. flow	ℓ/min(gal/min)	210(55)×2	20(5.3)
Max. input horse power	kW {PS}	107 {145}	3.4 {4.6}
Max. input torque	kgf·m (ft·lbs)	52(380)	1.5(11)
Regulator	Model	KR3G-9TIL	
	Control function	Electric flow control, redundant full power control, redundant power shift control and negative flow control	
	Others	With solenoid proportional reducing valve (KDRDE5K-31/30C40-111)	
Weight	kg(lbs)	126(278)	

Note: The max. input power and the max. input torque of the main pump include those of the gear

1) Adjusting the Outer Spring (See Fig. 1-9)

(At back-up control)

Adjust it by loosening lock nut (630) and by tightening adjust screw C (628) (or loosening it). Tightening the adjust screw shifts the control chart to the right and increases the input horsepower, as indicated in Fig.1-18.

Since turning the adjust screw C by N turns changes the setting of the inner spring, return the adjust screw (925) by 2.2N turns at first.

Adjust screw No.	628
No. of turns for tightening	1/4
Increase in delivery pressure kgf/cm ² (psi)	17.8 (250)
Increase in input torque kgf·m (ft·lbs)	4.7 (34)

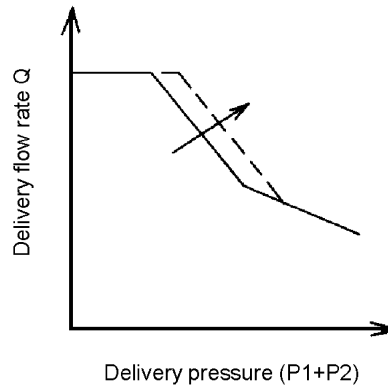

Fig.1-18 Adjusting the input horsepower (1)

2) Adjusting the Inner Spring (See Fig. 1-9)

(At back-up control)

Adjust it by loosening nut (801) and by adjust screw (925) (or loosening it). Tightening the adjust screw increases the flow and then the input horsepower, as indicated in Fig.1-19. And the input torque raises.

Adjust screw No.	925
No. of turns for tightening	1/4
Increase in flow ℓ/min (gal/min)	18.4 (4.9)
Increase in input torque kgf·m (ft·lbs)	3.2 (23)

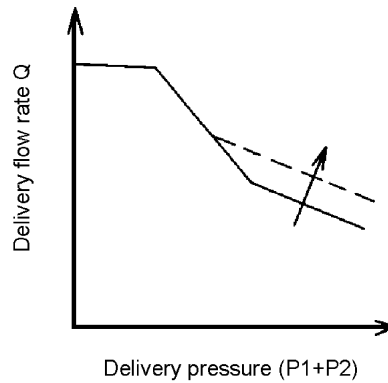

Fig.1-19 Adjusting the input horsepower (2)

(4) Adjusting the flow control characteristics (See Fig. 1-9)

Adjust them by loosening nut (801) and socket screw (924) (or loosening it). Socket screw causes the control chart to move to the right as shown in Fig.1-20. Socket screw raises the flow control start pilot pressure. And the delivery rate increases.

Adjust screw No.	924
No. of turns for tightening	1/4
Increase Pilot pressure Pi kgf/cm ² (psi)	1.3 (18)
Increase input current I mA	21mA
Increase in delivery flow ℓ/min (gal/min)	13.0 (3.4)

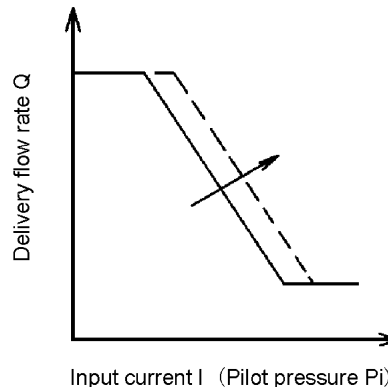

Fig.1-20 Adjusting the flow control

3.3 OPERATION

(1) Construction

The valve consists of the following parts in terms of hydraulic function :

- A : Damper section
- B : Reducing valve section
- C : Shuttle section

(2) Operation

1) Damper section

- If the primary pressure is supplied by P, it is flowed to the damper chamber by way of circuits ① and ② .

The pressure is then filled up in the damper chamber via the orifice and the check valve.

In that case, the air present in the damper chamber is pushed out to the T port from circuits ③ and ④ , in order to prevent the damper characteristics from fluctuating by air mixture.

- If the cam operates during travel operation, the oil in the damper chamber is kept from flowing back by the check valve. Thus the oil flows to part ⑤ only from the orifice. Damper action operates by the resistance that is built up as the oil passes through the orifice.

Let us explain the profile of the piston (See Fig. 3-4.)

The upper part of the piston has a diameter of 12mm(0.472in), while the lower part of it has a diameter of 11mm(0.433in). This results in an areal difference, with the result that the piston is constantly subject to a vertical force.

For this reason, the orifice rises by the pressure caused by the areal difference between the operating part of the cam and the piston on the opposite side i.e. the piston follows the cam.

That is to say, constant damper action operates wherever the cam is located.

Since the larger diameter of the piston, the cover, the 11mm diameter part of the piston and the guide are manufactured with minimal clearance, only a little leakage occurs. Consequently, the damper performance is not affected at all.

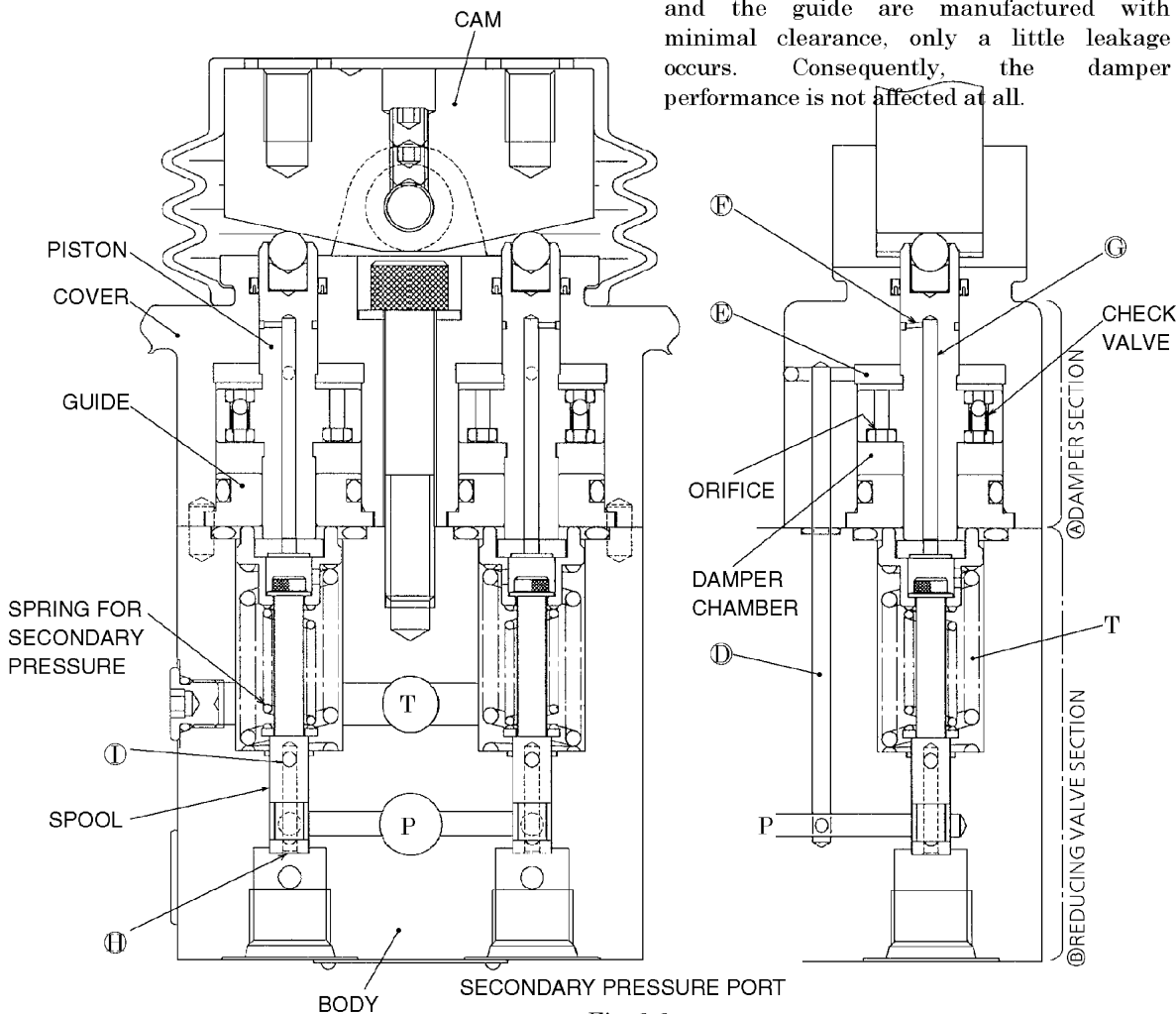

Fig. 3-3

4.3 HYDRAULIC CIRCUIT

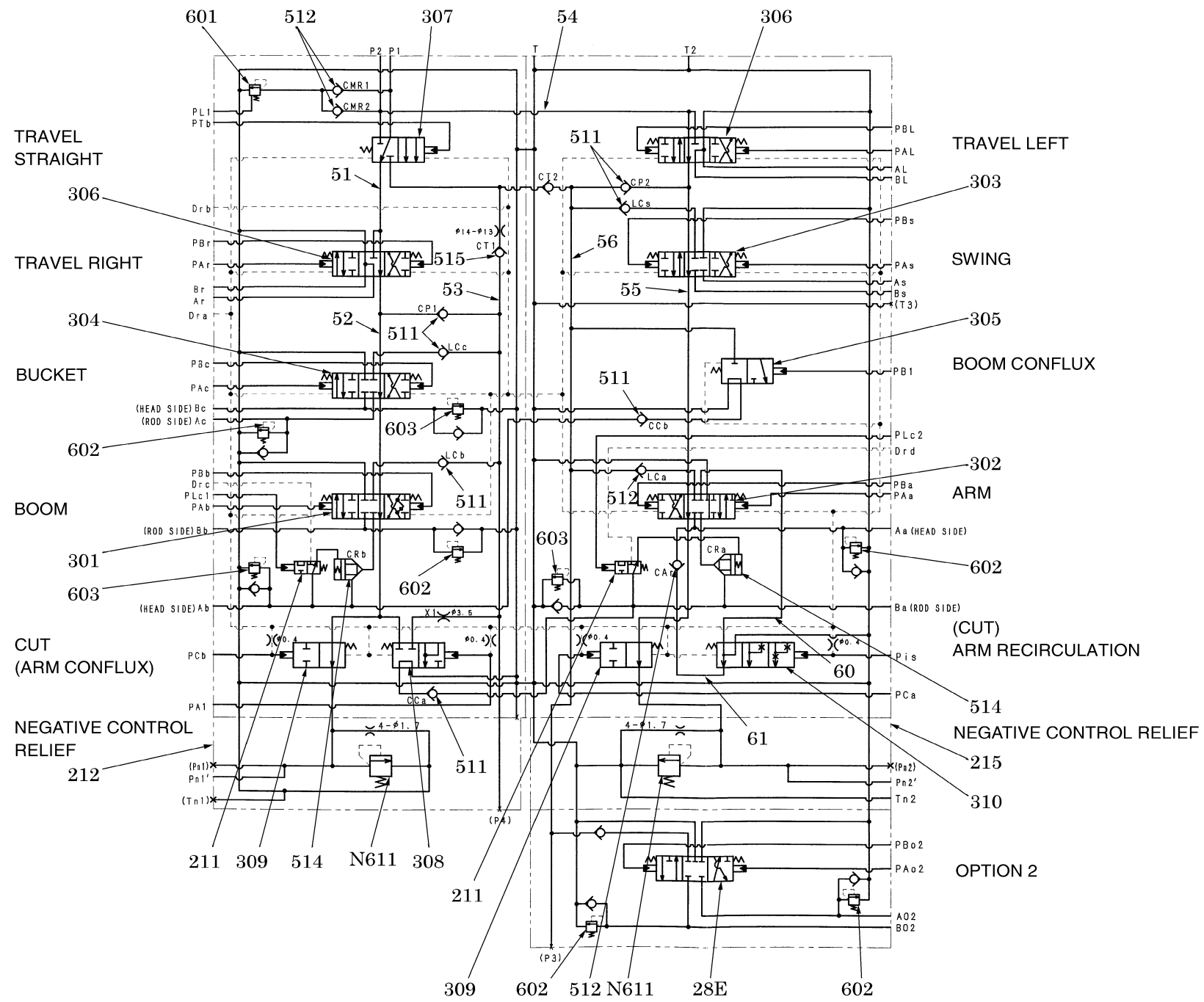

Table 4

No.	NAME
51	Main passage (P1 side)
52	Bypass circuit (P1 side)
53	Parallel circuit (P1 side)
54	Main passage (P2 side)
55	Bypass circuit (P2 side)
56	Parallel circuit (P2 side)
60	Arm recirculation passage
61	Arm recirculation low pressure passage
211	Lock valve selector spool
212	Negative control relief valve block
215	Negative control relief valve block
301	Boom spool
302	Arm spool
303	Swing spool
304	Bucket spool
305	Boom conflux spool
306	Travel spool
307	Travel straight spool
308	Arm conflux spool
309	P1,P2 bypass cut spool
310	Arm recirculation spool
511	Poppet (D=25)
512	Poppet (D=20)
514	Lock valve poppet
515	Poppet (with restrictor)
601	Main relief valve
602	Port relief valve
603	Port relief valve
28E	Spool for option valve
N611	Negative control relief valve

Fig. 4-10 Hydraulic circuit

2) Arm out conflux

In operation 1), the oil delivered by pump P1 flows into the bypass circuit (52) through the main passage (51), but since the bypass circuit (52) and the low pressure circuit (D) are blocked by the bypass cut spool (309), it does not run into the low pressure circuit (D). Meanwhile, since the arm conflux spool (308) has now been changed over, the pressure oil of the bypass circuit (52) goes between the outer circumference of the arm conflux spool (308) and the casing.

Part of the delivered oil passes through the parallel circuit (53) and the restrictor, combines with the pressure oil of the bypass circuit (52), pushes the conflux check poppet (511) open, enters port Ba by way of the conflux circuit in the casing and finally combines with the pressure oil on the pump P2 side.

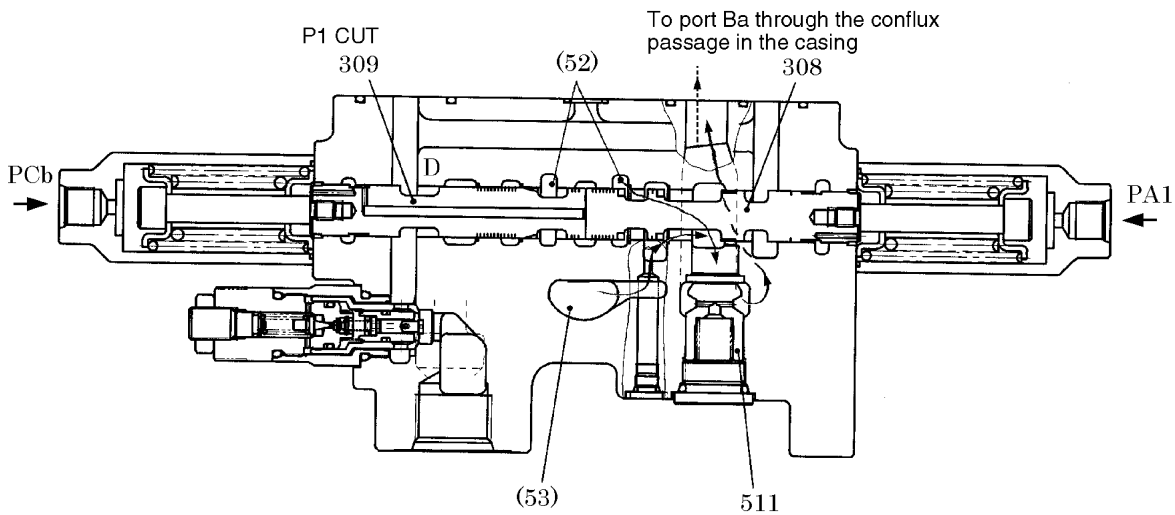

Fig. 4-21 At arm out operation (Bypass cut spool and arm conflux spool)

2) At boom lower action :

Operation	C/V Port name	
	Pilot secondary pressure side	Main pressure oil supply side
Boom lower	PBb PLc1	Bb
Arm in	PBa PLc2	Ab

The secondary pilot pressure from port ④ of the pilot valve acts upon the PBb port of the control valve and the PLc1 port of the lock valve selector and shifts the boom spool (301) to the right. At the same time, the pressure shifts the spool (S511) of the lock valve selector to the right.

As the spool (S511) is shifted, the orifice (a) in the bushing (S541) closes. This shuts off the continuity from passage Sa to passage Sb in the lock valve selector (211) and the hold pressure received from the boom cylinder (H) side ceases to act upon the spring chamber (RH) of the lock valve poppet (514).

As the spool (S511) moves, continuity is established from the orifice (b) of the bushing

(S541) to the drain port (Drc) through the inside of the bushing (S541).

This causes the orifice (b) of the bushing (S541) to connect with the passage Sb, the spring chamber of the lock valve poppet (514) and the low pressure circuit. The lock valve poppet (514) is received by the ring-shaped pressure bearing area that consists of the guide diameter and the seat diameter of the lock valve poppet (514), so that the lock valve poppet is pushed open upwards to release the lock function.

The operation described above is performed before the opening (meter out opening) which is used to return the return oil from the boom cylinder (H) side of boom spool (301) to the tank while performing the boom lower operation. Therefore, the action does not affect the controllability of the boom lower motion.

The operation is the same as the arm in operation.



DETAIL OF LOCK VALVE SELECTOR SPOOL (211)

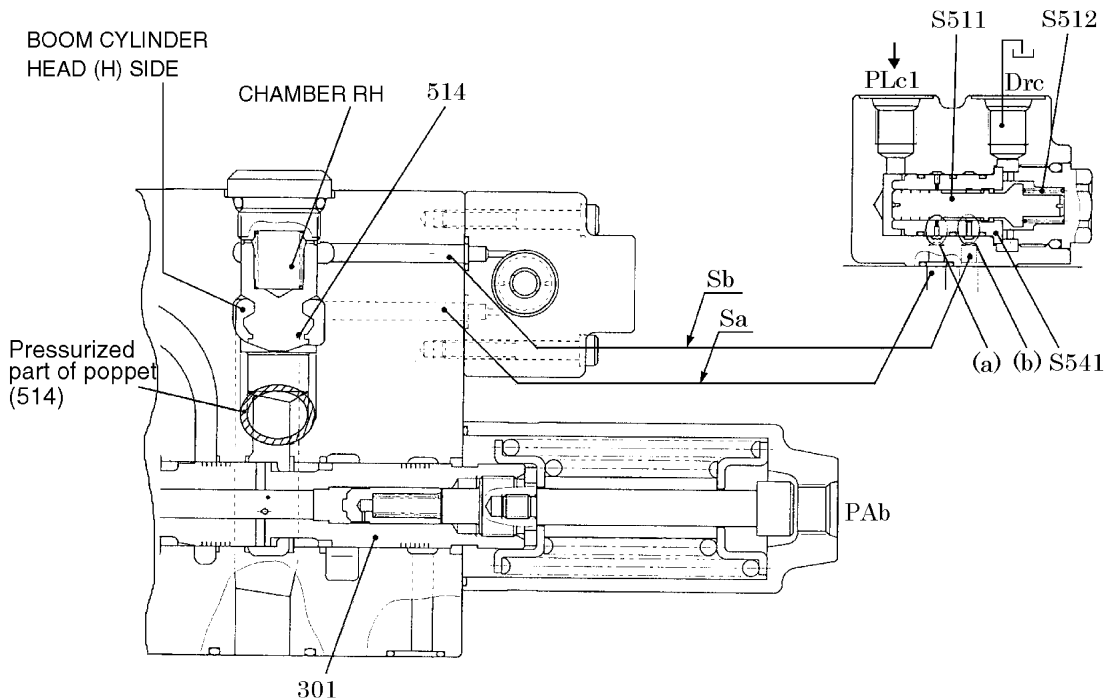

Fig. 4-28 Functions of lock valve (at boom lower)

(3) Operation of swing shockless valve

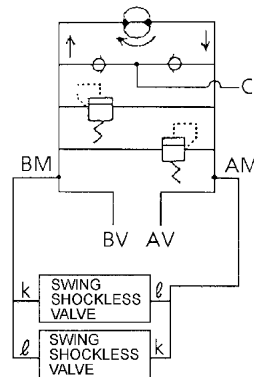

Fig. 5-8 Hydraulic circuit diagram for swing shockless valve.

1) Neutral condition :

Fig.5-8 illustrates the relationship between the neutral condition of the swing shockless valve and the hydraulic circuits. Now, let us consider a braking condition in which brake pressure generates on the AM port side.

2) When brake pressure occurs :

If pressure (P) generates at the AM port, it passes through the passage l, the hole on the shaft of seat (313) and the passage m of plunger (311) and is admitted to the n chamber.

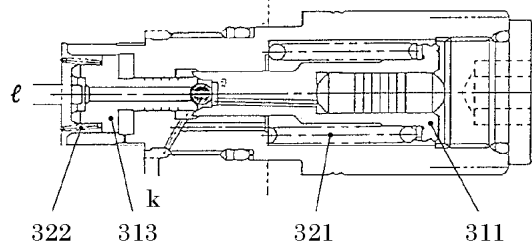

Fig. 5-9(1) Neutral condition

When the pressure P rises above a value (Ps) set by spring (321), plunger (311) compresses spring (321) and shifts it to the left.

Seat (313) compresses weak spring (322) as pushed by plunger (311) and moves to the left.

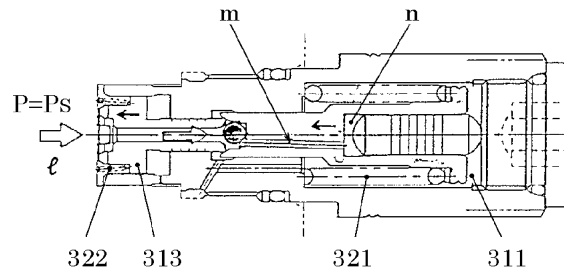

Fig. 5-9(2) When brake pressure occurs

3) At swing shockless action

When inertia load stops moving (point Y, Fig.5-10), brake pressure (P) tries to fall.

When $P < P_s$, plunger (311) moves toward the right return side by the action of spring (321). Seat (313) tries to move to the right by the action of spring (322), but since chamber p provides damping action by orifice g, the return of the seat makes a time delay with regard to the return of the plunger.

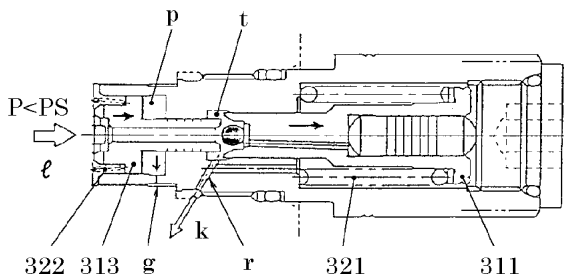

Fig. 5-9(3) At swing shockless action

Consequently, seat t opens. This makes a passage connecting the AM port and BM ports or both ports of the hydraulic motor by way of

$\rightarrow t \rightarrow r \rightarrow k$. The result is that the pressures at the AM and BM ports become equal (P_B), falling into the condition at point Z in Fig.5-10. This prevents the hydraulic motor from swing shock by the closing pressure of the AM port.

Fig. 5-9 Operation of swing shockless valve

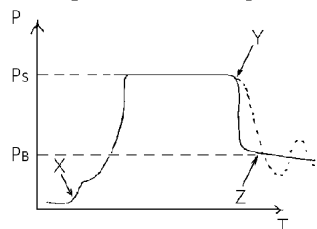

Fig. 5-10 Pressure change diagram of swing shockless operation

(4) Function of overload relief valve

Two overload relief valves are arranged in the crossover and operate as below :

- 1) To stop the hydraulic motor, the system keeps the braking pressure generating on the motor discharge side at a certain level to stop inertia load.
- 2) At start, the hydraulic motor is driven at a specified set pressure to make sharp acceleration. At stop, generated pressure is held low for a short time to dampen shocks by braking the motor.

Further, the circuit pressure is held at a set pressure so the reduction and travel crawler sprockets are engaged smoothly.

In short, boost pressure cushioning action is performed.

If the A port pressure of the overload relief valve rises at the start of the hydraulic motor, it acts upon the effective circumference on which valve seat (44-3) of valve (44-2) is seated and upon connecting piston (44-4) in the valve (44-2) through the small holes of it. The valve (44-2) causes the pressure to rise to a set pressure by standing against adjust spring (44-9) by the areal difference between the effective circumference of the valve seat and the circumference of the connecting piston.

When the hydraulic motor is braked, piston (44-7) at the back of the valve is on its left by the drive pressure. As the A port pressure rises, it acts upon piston (44-7) through the small hole in the valve. The piston moves to the right till the piston hits plug (44-5). During this period, valve (44-2) holds the A port pressure relatively low, counteracting adjust spring (44-9) and discharges the oil to the B port side.

After piston (44-7) strikes plug (44-5), the valve operates the same way as at the start of the motor.

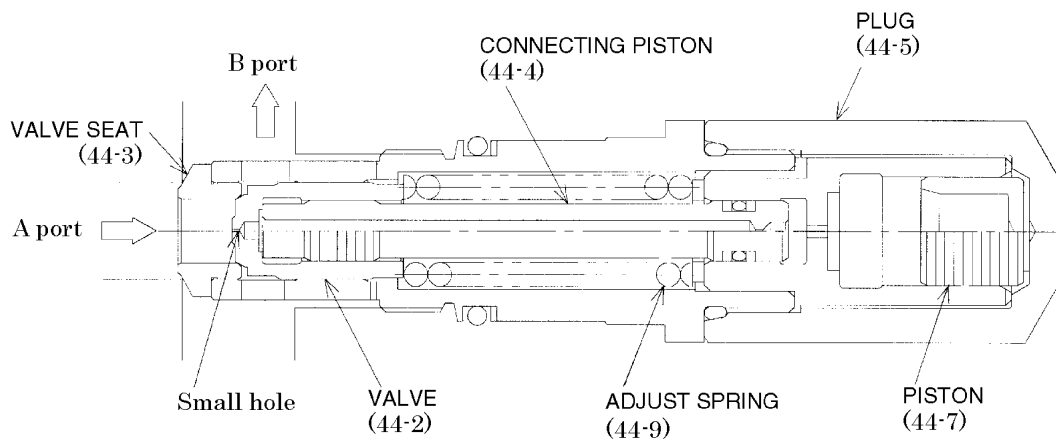

Fig. 6-9 Function of overload relief valve

8.2 CONSTRUCTION

(1) Boom cylinder

T=Tightening torque ; kgf·m (ft·lbs)

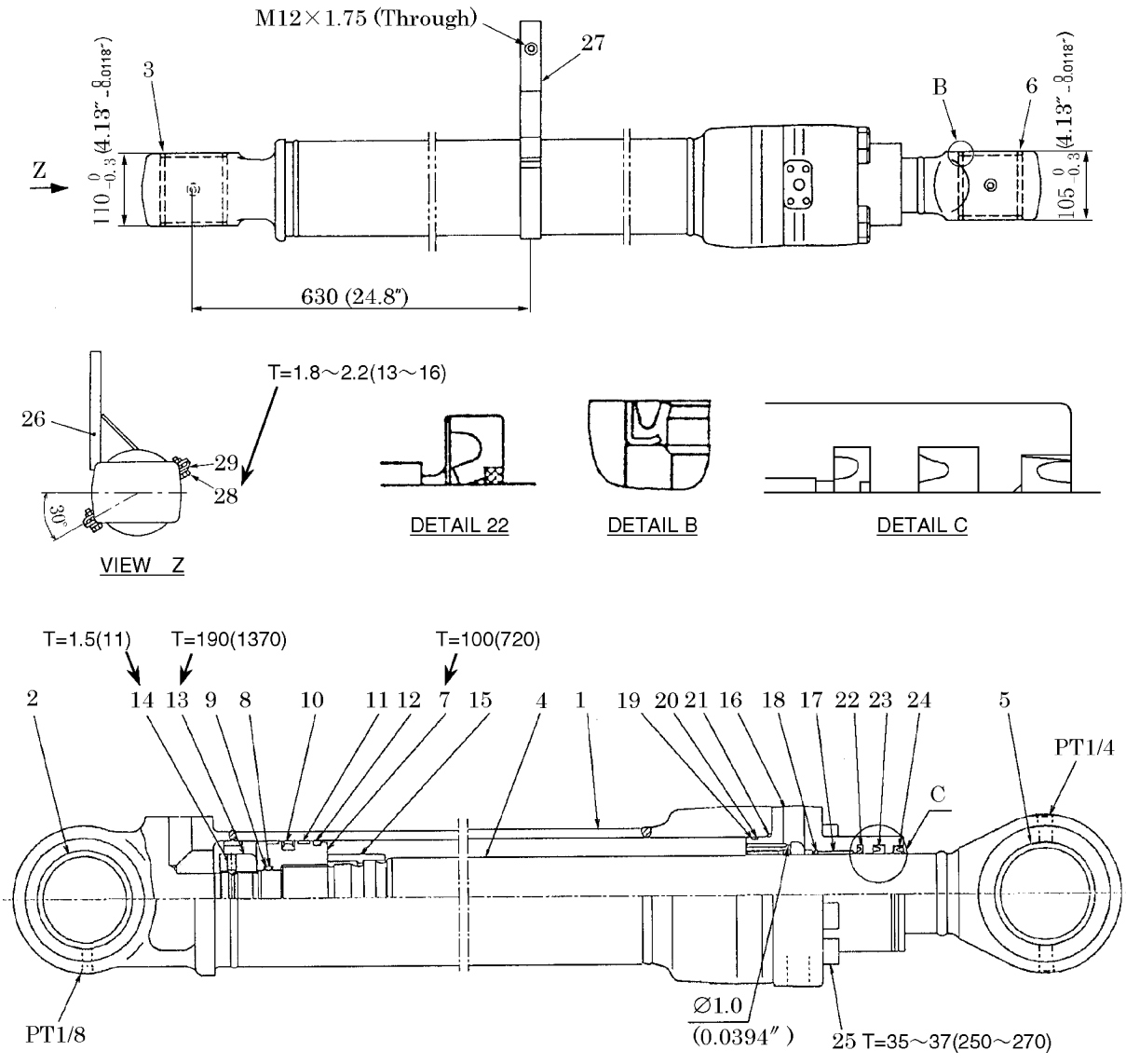
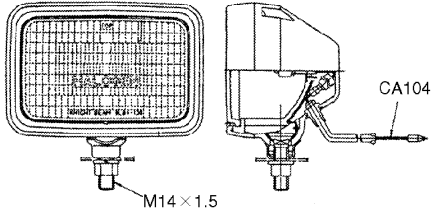
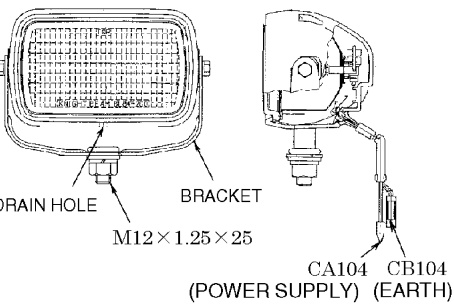
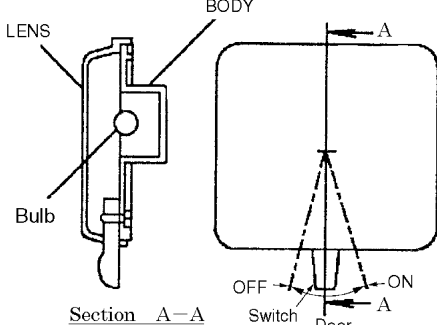
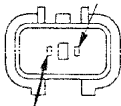
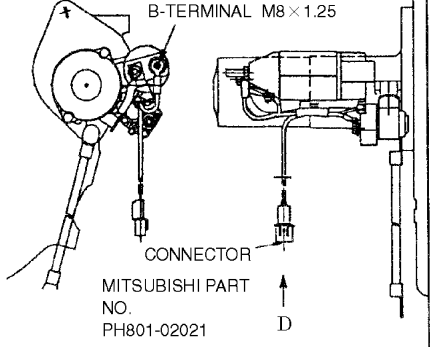

Fig. 8-2 Construction of boom cylinder
(The figure shows the right-hand cylinder.)

P/No.		YN01V00037F1		YN01V00038F1				
No.	NAME	QTY	No.	NAME	QTY	No.	NAME	QTY
1	CYLINDER TUBE	1	11	WEAR RING	2	21	O RING ; 1B G125	1
2	BUSHING	1	12	DUST RING	1	22	BUFFER SEAL	1
3	DUST SEAL	2	13	PISTON NUT	1	23	ROD PACKING	1
4	PISTON ROD	1	14	SET SCREW ; M8	1	24	DUST SEAL	1
5	PIN BUSHING	1	15	CUSHION RING	1	25	SOCKET BOLT ; M16x140	10
6	DUST SEAL	2	16	ROD COVER	1	26	BAND	1
7	PISTON	1	17	BUSHING	1	27	BAND	1
8	O RING ; 1B G65	1	18	SURCLIP	1	28	CAPSCREW ; M10x30	2
9	BACKUP RING	2	19	O RING ; 1B G120	1	29	LOCK WASHER	2
10	PISTON SEAL	1	20	BACKUP RING	1			

NOTES

NOTES

File No. Name of part Part No. Use Applicable Machine	Specification	Description						
<p>L-1</p> <p>Light</p> <p>YW80S00001F1</p> <p>Boom work light (left)</p> <p>YN23301~, YQ02801~ YX01001~, YV00101~ YY00101~, YF00101~ YN07-30001~, YQ07-03501~ LQ08-04501~, LL08-03001~</p>	<table border="1"> <tr> <td>Type</td> <td>BL84-130</td> </tr> <tr> <td>Bulb</td> <td>24V,70W</td> </tr> </table>	Type	BL84-130	Bulb	24V,70W			
Type	BL84-130							
Bulb	24V,70W							
<p>L-2,7,8,9</p> <p>Light</p> <p>YN80S00010F2</p> <p>Deck work light (Right)</p> <p>OPT: Cab work light (L&R) OPT: Boom cylinder work light</p> <p>YW07901~, LP13601~ YN23301~, YQ02801~ LQ03701~, YF00101~ YN07-30001~, YQ07-03501~ LQ08-04501~, LL08-03001~</p>	<table border="1"> <tr> <td>Type</td> <td>BL84-200</td> </tr> <tr> <td>Bulb</td> <td>DC 24V,70W</td> </tr> <tr> <td>Effective area of lens</td> <td>71cm²</td> </tr> </table>	Type	BL84-200	Bulb	DC 24V,70W	Effective area of lens	71cm ²	
Type	BL84-200							
Bulb	DC 24V,70W							
Effective area of lens	71cm ²							
<p>L-5</p> <p>Light</p> <p>YT80S00001P1</p> <p>Room light</p> <p>YW06501~ LP11001~, YP02301~ YN18001~, YQ02301~ LQ03301~, LL02301~ YN07-30001~, YQ07-03501~ LQ08-04501~, LL08-03001~ LC06-05501~, YC06-02501~</p>	<table border="1"> <tr> <td>Bulb</td> <td>24V,5W</td> </tr> </table> <p>Note) Equivalent to 2456Z322F1</p>	Bulb	24V,5W					
Bulb	24V,5W							
<p>M-1</p> <p>Motor</p> <p>ME049303</p> <p>Starter motor</p> <p>YF00101~ YN07-30001~, YQ07-03501~ LQ08-04501~, LL08-03001~ LC06-05501~, YC06-02501~</p>	<table border="1"> <tr> <td>Rated output</td> <td>DC24V, 5.0kW</td> </tr> <tr> <td>MITSUBISHI part No.</td> <td>ME049303</td> </tr> </table> <p>L- TERMINAL</p>  <p>VIEW D</p>	Rated output	DC24V, 5.0kW	MITSUBISHI part No.	ME049303			
Rated output	DC24V, 5.0kW							
MITSUBISHI part No.	ME049303							

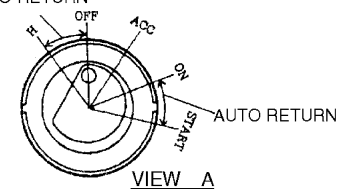
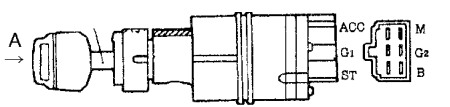
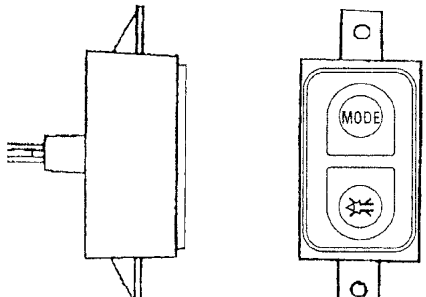
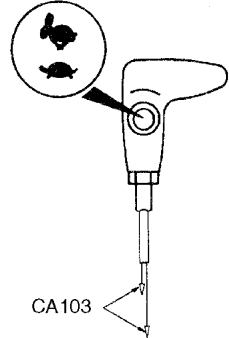
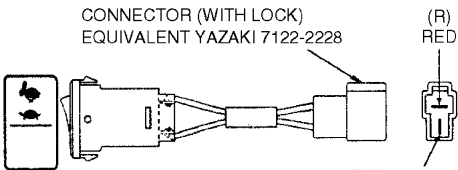
File No. Name of part Part No. Use Applicable Machine	Specification	Description																																																
<p>SW-1</p> <p>Switch</p> <p>YN50S00002F1</p> <p>Starter switch</p> <p>YW06501~ LP11001~ YP02301~ YN18001~ YQ02301~ LQ03301~ LL02301~ YT00101~ YR04001~ YX00101~ YV00101~ YF00101~ YP00101~ YN07-30001~ YQ07-03501~ LQ08-04501~ LL08-03001~ LC06-05501~ YC06-02501~</p>	<table border="1"> <tr> <td>P</td> <td>T</td> <td>B</td> <td>G1</td> <td>G2</td> <td>ACC</td> <td>M</td> <td>ST</td> </tr> <tr> <td>H</td> <td></td> <td>○</td> <td>○</td> <td></td> <td></td> <td></td> <td></td> </tr> <tr> <td>OFF</td> <td></td> <td></td> <td></td> <td></td> <td></td> <td></td> <td></td> </tr> <tr> <td>ACC</td> <td></td> <td>○</td> <td></td> <td></td> <td>○</td> <td></td> <td></td> </tr> <tr> <td>ON</td> <td></td> <td>○</td> <td></td> <td></td> <td>○</td> <td>○</td> <td></td> </tr> <tr> <td>START</td> <td></td> <td>○</td> <td></td> <td>○</td> <td></td> <td>○</td> <td>○</td> </tr> </table>	P	T	B	G1	G2	ACC	M	ST	H		○	○					OFF								ACC		○			○			ON		○			○	○		START		○		○		○	○	<p>AUTO RETURN</p>  <p>VIEW A</p> <p>"K250" STAMPED</p>  <p>TERMINAL ARRANGEMENT</p>
P	T	B	G1	G2	ACC	M	ST																																											
H		○	○																																															
OFF																																																		
ACC		○			○																																													
ON		○			○	○																																												
START		○		○		○	○																																											
<p>SW-2</p> <p>Switch</p> <p>YN50E00002F1</p> <p>Mode, buzzer stop</p> <p>YN07-30001~ YQ07-03501~ LQ08-04501~ LL08-03001~ LC06-05501~ YC06-02501~</p>	<table border="1"> <tr> <td>Type</td> <td>Sheet type, with back light</td> </tr> </table>	Type	Sheet type, with back light																																															
Type	Sheet type, with back light																																																	
<p>SW-3</p> <p>Switch</p> <p>YN03M01039P1 (Right travel grip)</p> <p>Travel 1,2-speed</p> <p>YW06501~ LP11001~ YP02301~ YN18001~ YQ02301~ LQ03301~ LL02301~ YN07-30001~ YQ07-03501~ LQ08-04501~ LL08-03001~</p>	<table border="1"> <tr> <td>Type</td> <td>Buried in right travel lever</td> </tr> </table>	Type	Buried in right travel lever	<p>MARKS ON SWITCH PORTION</p>  <p>CA103</p>																																														
Type	Buried in right travel lever																																																	
<p>SW-3</p> <p>Switch</p> <p>2479U1224F4</p> <p>Travel 1,2-speed</p> <p>YN07-30001~ YQ07-03501~ LQ08-04501~ LL08-03001~ LC06-05501~ YC06-02501~</p>	<table border="1"> <tr> <td>Type</td> <td>Single-pole single-throw momentary</td> </tr> <tr> <td>Rated voltage</td> <td>DC 24V</td> </tr> <tr> <td>Insulation resistance</td> <td>More than 1MΩ / DC500V megger</td> </tr> </table> <p>TERMINAL CONNECTOR</p> <table border="1"> <tr> <td>Terminal Position</td> <td>R</td> <td>RW</td> <td></td> </tr> <tr> <td>OFF</td> <td></td> <td></td> <td></td> </tr> <tr> <td>ON</td> <td>○</td> <td>○</td> <td></td> </tr> </table>	Type	Single-pole single-throw momentary	Rated voltage	DC 24V	Insulation resistance	More than 1MΩ / DC500V megger	Terminal Position	R	RW		OFF				ON	○	○		<p>CONNECTOR (WITH LOCK) EQUIVALENT YAZAKI 7122-2228</p>  <p>(R) RED RED / WHITE</p>																														
Type	Single-pole single-throw momentary																																																	
Rated voltage	DC 24V																																																	
Insulation resistance	More than 1MΩ / DC500V megger																																																	
Terminal Position	R	RW																																																
OFF																																																		
ON	○	○																																																

CHAPTER 25

AIR CONDITIONING SYSTEM

TABLE OF CONTENTS

25.1 CONSTRUCTION AND PIPING	
25.1.0.1 Intake Unit	25-3
25.1.0.2 Piping	25-4
25.1.0.3 Heater Circuit	25-5
25.2 MAIN COMPONENT CONSTRUCTION	
25.2.1 Intake Unit	25-6
25.2.1.1 aIR cONDITIONER uNIT	25-7
25.2.2 Component Construction	25-8
25.2.2.1 Intake Unit	25-8
25.2.2.2 Unit Construction	25-9
25.2.3 Air Conditioner Function	25-11
25.2.3.1 Mechanism	25-11
25.2.3.2 Component Parts	25-13
25.2.3.2.1 Evaporator	25-13
25.2.3.2.2 Expansion Valve	25-13
25.2.3.2.3 Compressor	25-15
25.2.3.2.4 Condenser	25-15
25.3 DISASSEMBLY AND ASSEMBLY	
25.3.1 Removal and installation	25-18
25.3.1.0.1 Removing the blower unit	25-18
25.3.1.0.3 Replacing the blower controller	25-18
25.4 CHARGING REFRIGERANT	
25.4.1 Precautions during charging	25-22
25.4.2 Operating Procedure	25-23
25.4.3 Charging Procedure	25-24
25.4.3.0.1 Creating Vacuum	25-24
25.4.4 Air tightness check	25-25
25.4.4.1 Gas Charging Operation	25-25
25.4.5 Checking amount of refrigerant	25-27
25.4.6 Detaching the gauge manifold	25-27
25.4.7 Electrical Circuit	25-28
25.4.8 Functional Parts Inspection	25-29
25.4.8.0.1 Relay	25-29
25.4.8.0.2 inner air sensor	25-29
25.4.8.0.3 blower controller	25-29
25.4.8.0.4 motor actuator	25-29
25.4.8.0.5 pressure switch	25-30
25.5 TROUBLESHOOTING	

CLICK HERE TO **DOWNLOAD** THE COMPLETE MANUAL

- Thank you very much for reading the preview of the manual.
- You can download the complete manual from: www.heydownloads.com by clicking the link below



- Please note: If there is no response to CLICKING the link, please download this PDF first and then click on it.

CLICK HERE TO **DOWNLOAD** THE COMPLETE MANUAL

25.2.3 AIR CONDITIONER FUNCTION

25.2.3.1 MECHANISM

1. Mechanism of Cooling

In the cooling process, the refrigerant that flows through the cooling circuit changes its characteristics from liquid to gas then from gas back to liquid as heat is transferred from the low temperature compartment to outside the machine.

A. Types of refrigerant

Different types of refrigerants are available and are subject to regulation. The EPA issues strict guidelines for refrigerants. The following requirements are necessary for use in machine applications.

Latent heat of vaporization should be high.

Refrigerant will liquefy or condense easily and does not require high pressure for condensation.

The refrigerant must evaporate in order to cool. It must not evaporate at too low a pressure.

Refrigerant is cooled by the expansion valve, and loss resulting from this must be held to a minimum. It must be stable chemically and not corrode or permeate into circuit parts.

Refrigerant should be free from objectionable odor, flammability, and/or combustion.

Always use an approved refrigerant. Table 1 shows the principal characteristics of R134a.

2. Characteristics of Refrigerant (See Fig. 6)

A. Refrigerant as a gas under certain pressure as it cools begins to condensate and become liquid. The temperature at which condensation occurs is unique at given pressures. The temperature determined by a given pressure is the saturation temperature. The pressure at which gas condenses at a determined temperature is saturation pressure. Fig. 7 illustrates the relationship between saturation temperature and saturation pressure for R134a.

Item	HFC-134a (R134a)
Chemical formula	CH ₂ FCF ₃
Molecular weight	102.03
Boiling point	-26.19°C (-15.14°F)
Critical temperature	101.14°C (214.05°F)
Critical pressure	4.065MPa (41.45kgf/cm ² *1)
Critical density	511kg/m ³ (31.9 lb/ft ³)
Density of saturated liquid [25°C (77.0°F)]	1206kg/m ³ (75.3 lb/ft ³)
Specific volume of saturated vapor [25°C (77°F)]	0.0310m ³ /kg (0.496ft ³ /lb)
Latent heat of vaporization [0°C (32°F)]	197.5KJ/kg {47.19kcal/kg}
Flammability	Nonflammable
Ozone destruction coefficient	0

*1 : 1MPa (mega pascal) equals 10.1972kgf/cm² (145psi)

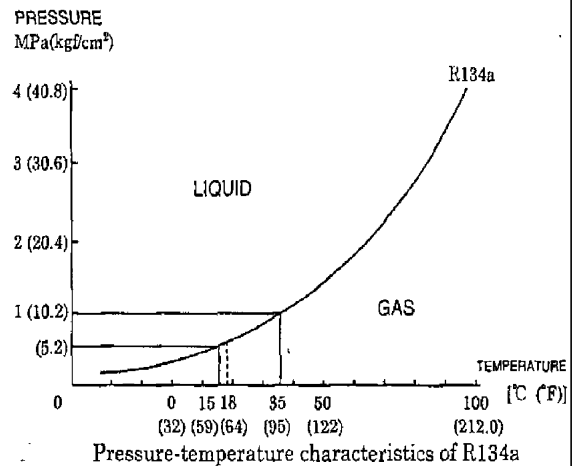

CH25-09-01

Figure 9

25.3.1.0.8 REPLACING THE AIR MIX MOTOR ACTUATOR

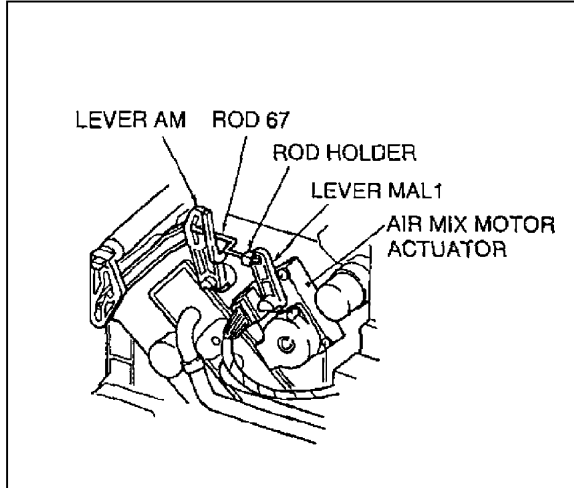

CH25-19-01

Figure 27

Remove the connector holding the motor actuator. Separate the Rod 67 linking the motor actuator with the lever AM from the rod holder. Remove the 3 Phillips screws T4X14 (T1) fastening the motor actuator. Remove the motor actuator with the rod holder and the lever MAL1 from the unit. Remove the rod holder and the lever MAL1 from the motor actuator. Reinstall the rod holder and the lever MAL to a new motor actuator. Assembly is the reverse order of disassembly.

25.3.1.0.9 REPLACING THE AIR SELECT MOTOR ACTUATOR

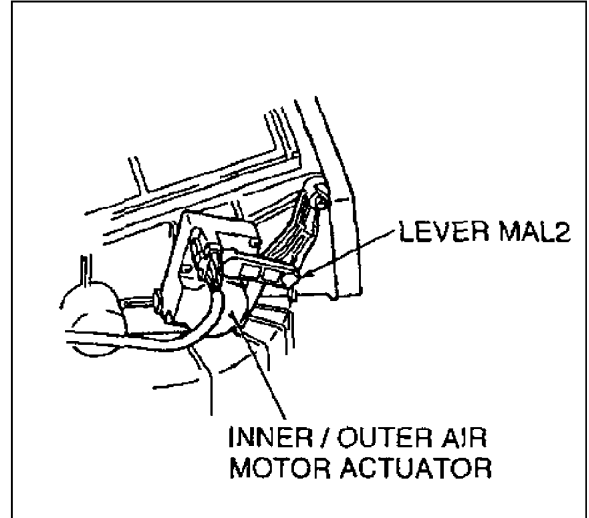

CH25-19-02

Figure 28

To replace the inner/outer air select motor actuator, remove the connector holding the motor actuator. Separate the motor actuator with lever MAL2 from the unit. Remove the lever MAL2 from the motor actuator and reinstall it to a new motor actuator. Assembly is the reverse order of disassembly.

25.5 TROUBLESHOOTING

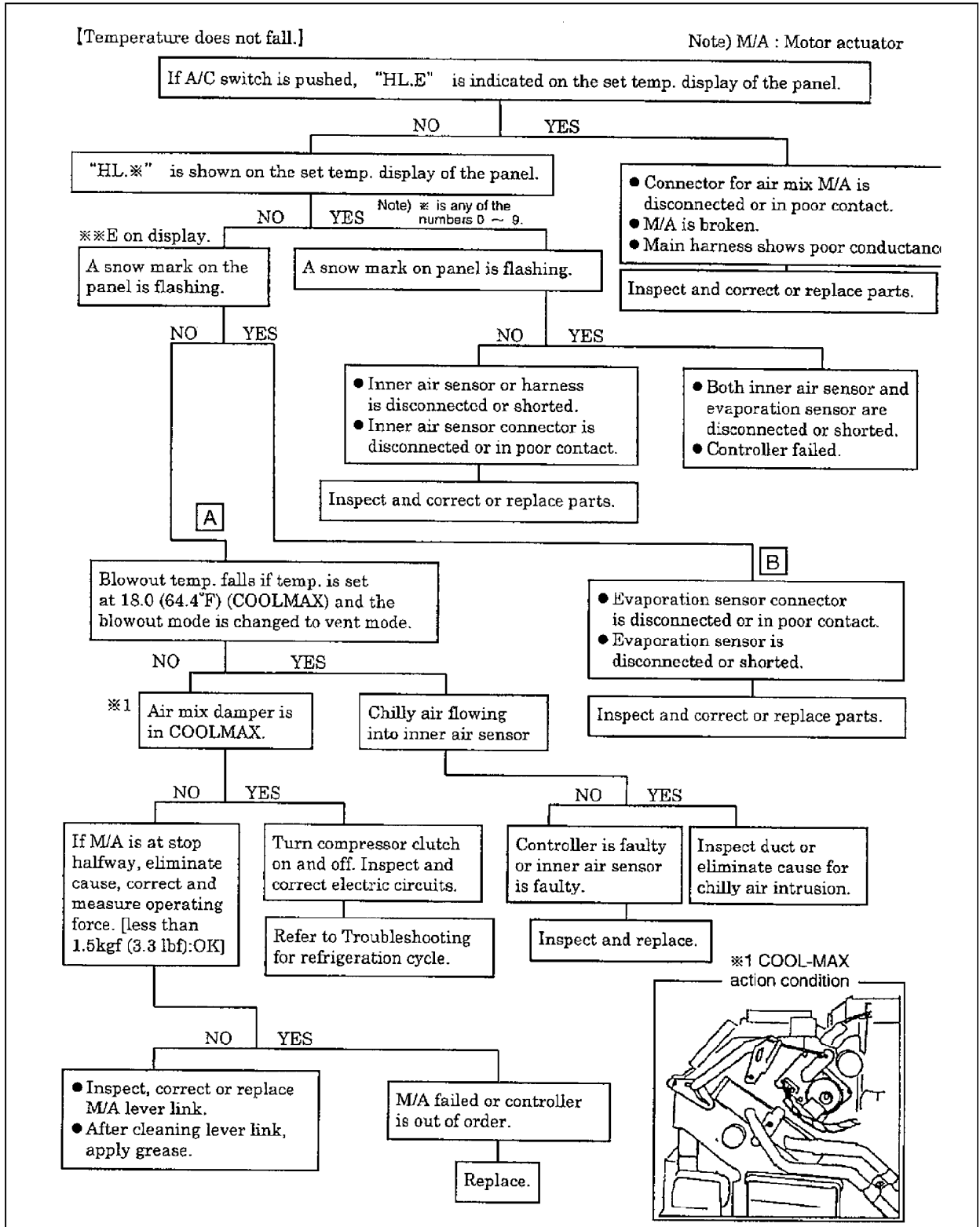

CH25-31-01ID

Figure 49

SECTION 3 - DISASSEMBLY AND ASSEMBLY

CHAPTER 31
E215
CRAWLER EXCAVATORS

GENERAL DISASSEMBLY AND ASSEMBLY

32.1 REMOVING AND INSTALLING

32.1.1 ATTACHMENT ASSEMBLY AND NAME

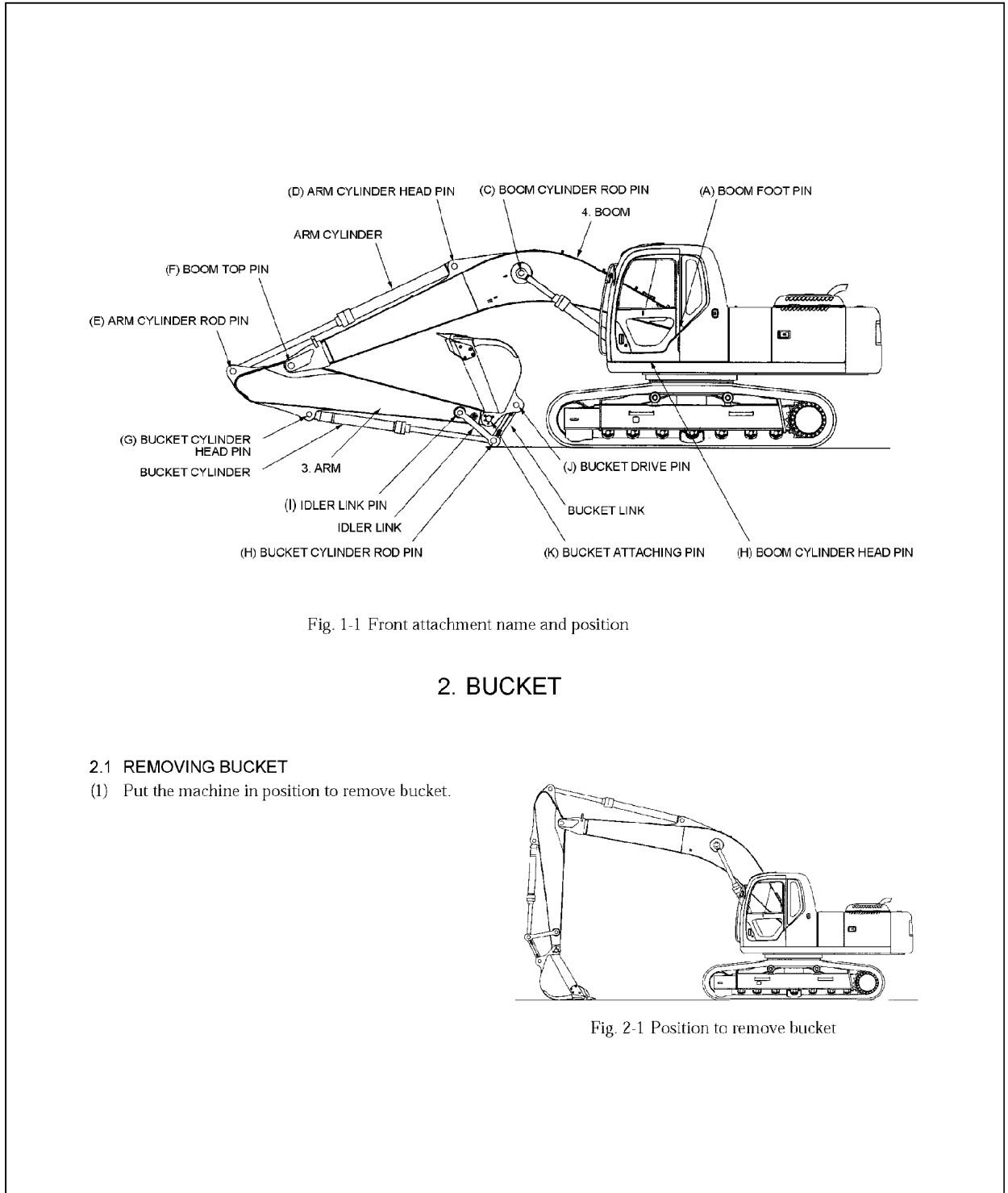

Fig. 1-1 Front attachment name and position

2. BUCKET

2.1 REMOVING BUCKET

- (1) Put the machine in position to remove bucket.

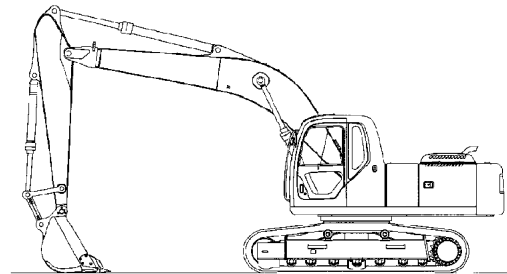

Fig. 2-1 Position to remove bucket

SECTION 3 - DISASSEMBLY AND ASSEMBLY
CHAPTER 32 - ATTACHMENTS

1.2 CONSTRUCTION OF CYLINDER (AN EXAMPLE OF BOOM CYLINDER)

T=Tightening torque ; kgf-m (ft-lbs)

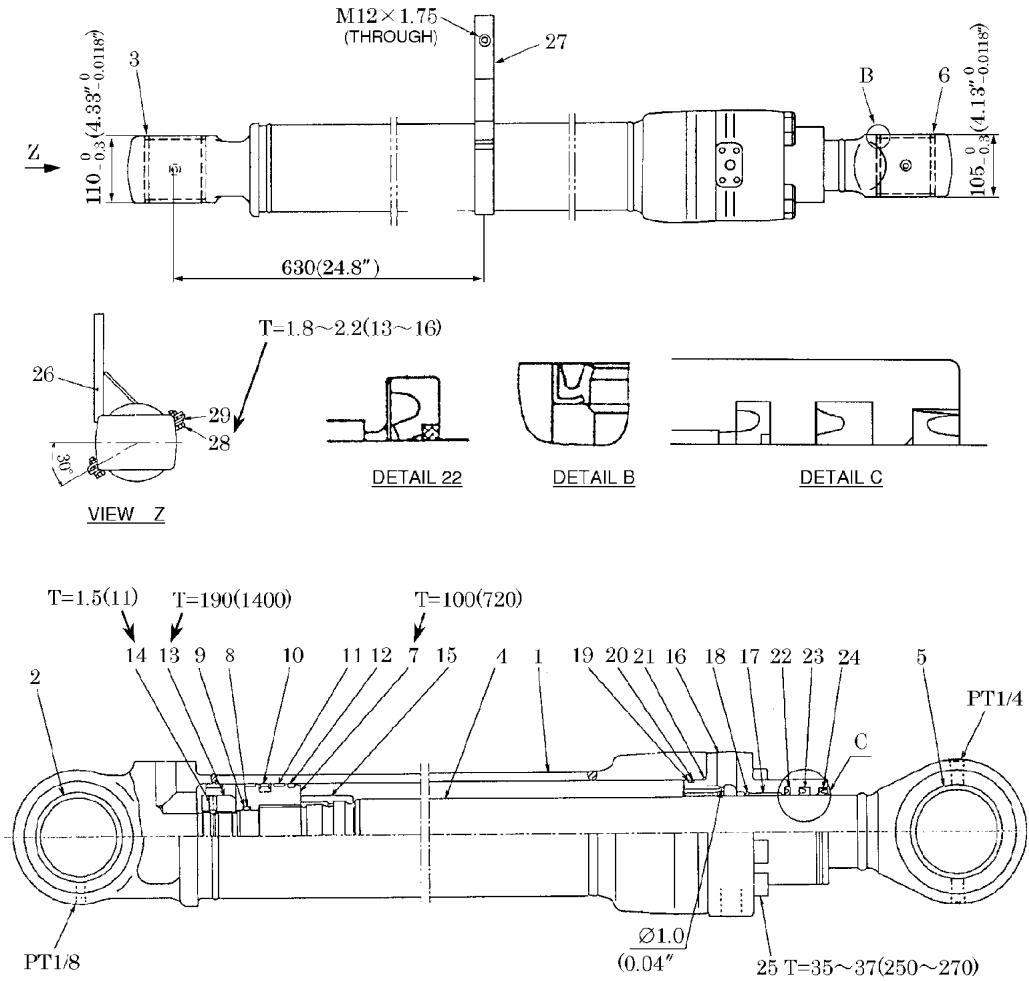
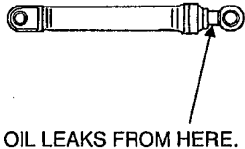
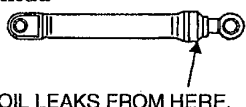
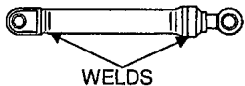

Fig. 1-3 Construction of boom cylinder
(The figure shows the right cylinder.)

No.	NAME	Q'TY	No.	NAME	Q'TY	No.	NAME	Q'TY
1	CYLINDER TUBE	1	11	WEARING	2	21	O RING ; 1B G125	1
2	BUSHING	1	12	DUST RING	1	22	BUFFER SEAL	1
3	DUST SEAL	2	13	PISTON NUT	1	23	ROD PACKING	1
4	PISTON ROD	1	14	SETSCREW ; M8	1	24	DUST SEAL	1
5	PIN BUSHING	1	15	CUSHION RING	1	25	SOCKET BOLT ; M16×140	10
6	DUST SEAL	2	16	ROD COVER	1	26	BAND	1
7	PISTON	1	17	BUSHING	1	27	BAND	1
8	O RING ; 1B G65	1	18	CIRCLIP	1	28	CAPSCREW ; M10×30	2
9	BACK-UP RING	2	19	O RING ; 1B G120	1	29	LOCK WASHER	2
10	PISTON SEAL	1	20	BACK-UP RING	1			

32.1.8 TROUBLESHOOTING

Table 1-16			
Trouble	Faulty Part	Cause	Remedy
<p>1. Oil leakage through sliding surface of piston rod oil ring is formed on piston rod, and the ring grows up to oil drops, and they drip.</p> 	1. Rod packing	<ol style="list-style-type: none"> Foreign matter is included in the bore of rod packing Lips on outer and inner diameter surfaces of rod packing are scored. Other rod packing are faulty. 	<ol style="list-style-type: none"> Remove foreign matter. Replace rod packing. Replace rod packing.
	2. Buffer seal	<ol style="list-style-type: none"> Foreign matter is caught in the bore of buffer seal. Flaw is present on the bore of buffer seal. Other buffer seals are faulty. 	<ol style="list-style-type: none"> Remove foreign matter. Replace buffer seal. Replace buffer seal.
	3. Dust seal	<ol style="list-style-type: none"> Foreign matter is include in the bore of dust seal. Lip on the bore of dust seal is scored. Other dust seals are faulty 	<ol style="list-style-type: none"> Remove foreign matter. Replace dust seal. Replace dust seal.
	4. Piston rod	<ol style="list-style-type: none"> Flaw is present on the sliding surface of piston rod. Hard chromium plating has peeled off 	<ol style="list-style-type: none"> Smooth out the sliding surface with an oilstone. If leakage occurs even if the sliding surface is finished below 1.6S, rod packings may be scored. Disassemble and inspect it and replace rod packings as required. If leakage will not stop by that treatment, replace piston rod. Replate.
<p>2. Oil leaks from the perimeter of cylinder head</p> 	1. O ring	1. O ring is damaged.	1. Replace O ring.
	2. Backup ring	1. Backup ring is damaged.	1. Replace backup ring.
<p>3. Oil leaks from welds.</p> 	1. Cylinder tube	1. Welds of cylinder are fractured.	1. Replace cylinder tube.
<p>4. Cylinder falls by it-self. [When the rod is loaded with a static load equal to the maximum working pre-ssure multiplied by the area of the cylinder bore, the maximum movement of the piston is more than 0.5mm (0.02") in ten minutes.]</p>	1. Piston seal	<ol style="list-style-type: none"> Foreign matter is caught on the sliding surface of slipper seal Flaw is present on the sliding surface of slipper seal. Other back rings are faulty. 	<ol style="list-style-type: none"> Remove foreign matter. Replace slipper seal. Replace back ring.
	2. Wear ring	1. Sliding surface of wear rings is scored.	1. Replace wear ring.
	3. O ring	1. O ring is scored.	2. Replace O ring.

1. OPERATOR SEAT

1.1 REMOVAL

- (1) Remove seat belt.
 - 1) Remove the head rest of the operator's seat to ease handling.
 - 2) Move the whole control stand to its foremost position.
 - 3) Move the operator's seat to its forward end.
 - 4) Incline the reclining seat as forward as possible.
 - 5) Remove the snap hook of the seat belt (1) from the eye bolts (2 places)

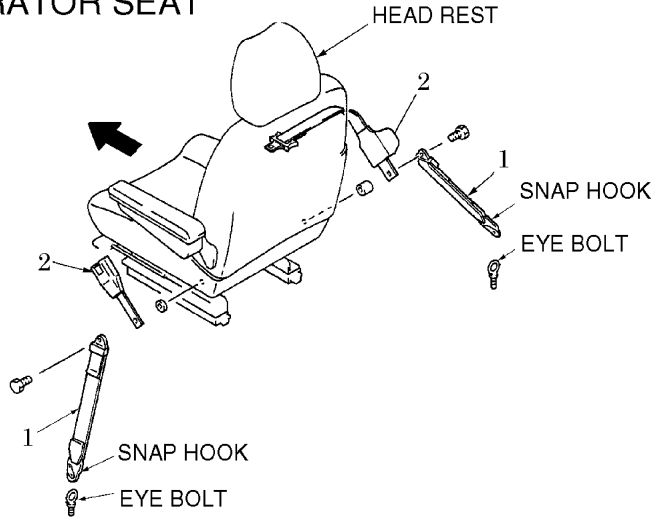

- (2) Remove operator's seat. (Include upper rail.)
 - 1) With the above-mentioned seat belt removed, remove two cap screws (A8) M8×20 from the upper rail. Then move the control stand to its rearmost end and remove two cap screws (A8) M8×20.

 : 6mm

- 2) Remove the operator's seat. [about 22kg (48 lbs).]

Before removing the cab, remove the A/C mounting cover assembly in this condition. This eases removal and fixing of harness connectors.

Carry out the following operations as required.

 - 3) Remove cover (A3).
 - 4) Remove support (A1).
 - 5) Remove seat stand (A2).

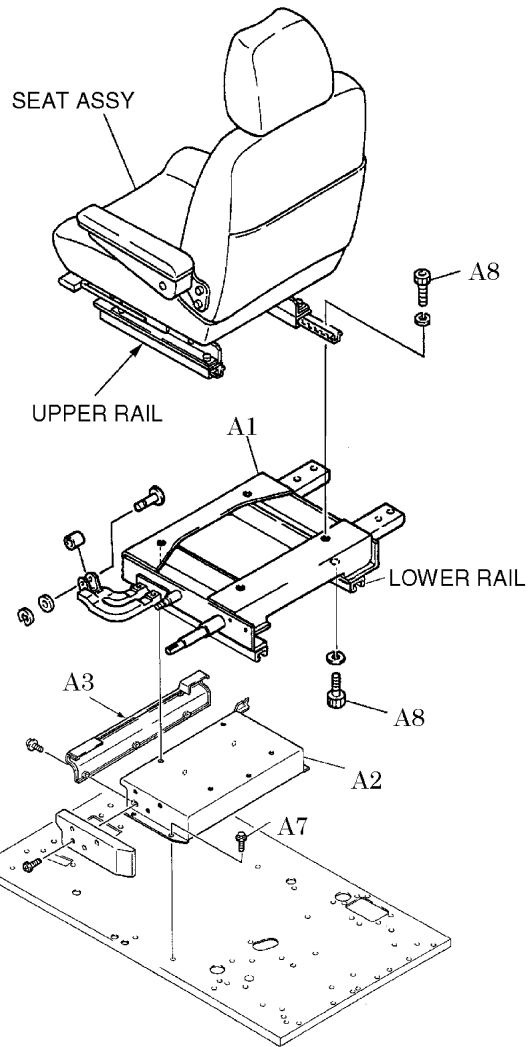

1.2 INSTALLATION

Install it in reverse procedure of removing according to the tightening torque table.

Tightening position	Allen wrench HEX	Tightening torque kgf·m (ft·lbs)
Sems bolt (A7)	17	4.7 (34)
Capscrew (A8)	6	4.3 (31)

Reference : Movement on rail

Upper rail Fixed on lower surface of seat
[Forward 80mm (0.26in), backward 80mm (0.26in)]

Lower rail Fixed on seat stand.
[Forward 60mm (0.19in), backward 60mm (0.19in)]

Amount of adjustment of seat height
[Up; 23mm (0.07in), down; 37mm (0.16in)]

Fig. 1-1 Disassembling and Assembling seat

6. FUEL TANK

6.1 PREPARATION FOR REMOVAL

- (1) Draining fuel.
 - 1) Unlock cap (A2) with a starter key and open it.
 - 2) Loosen cock (B8) under the tank.
(See Fig.6-2.)
 - 3) Draining fuel
Capacity of tank : 336ℓ (89gal)

- (2) Remove stay (29), panel (6) and guard (8).
(Refer to 4. GUARD)

- (3) Remove the connector for level sensor (B4).
(See Fig. 6-2)

- (4) Remove fuel hose
 - 1) Loosen clip (8) and draw out hoses (2) and (5).
 - 2) Put in plugs that match the hose bore.

6.2 REMOVAL

- 1) Remove four capscrews (B1) M16×40 and three shims (B3).

 : 24mm

- 2) Hook the wire to the lifting eye on the fuel tank assy and remove the fuel tank.

Weight : 91kg (201 lbs)

6.3 INSTALLATION

- (1) Installing is done in the reverse order of removing.

Tank attaching bolt (B1) M16×40

 : 24mm, Apply Locktite #262

Tightening torque : 22.0kgf·m (160ft·lbs)

- (2) Tightening torque

No.	NAME	QTY	Tightening torque kgf·m (ft·lbs)
A4	PLUG	1	5.0 (36)
B1	CAPSCREW	4	22 (160)
B6	MACHINE SCREW	5	0.2 (1.4)
B8	COCK	1	4.0 (29)

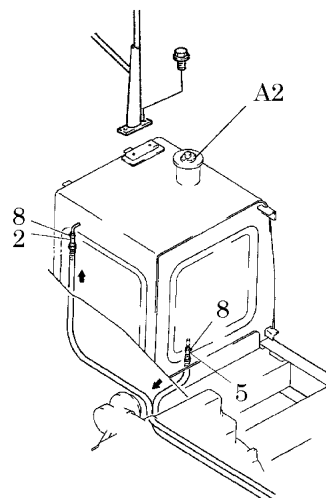

Fig. 6-1 Removing fuel hose (2), (5)

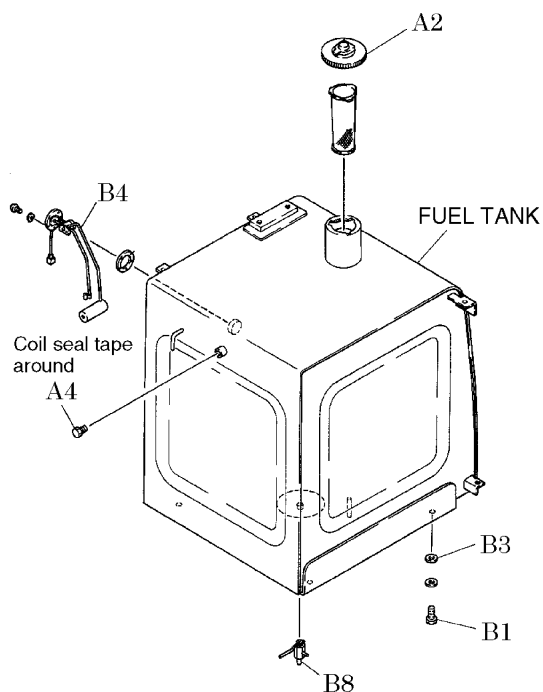

Fig. 6-2 Removing fuel tank

11. COUNTERWEIGHT

11.1 PREPARATION FOR REMOVAL

Remove plug (C6) on the counterweight and attach two M36 eye bolts (Refer to chapter “YN11 Tools”) to the counterweight.

 : 55mm

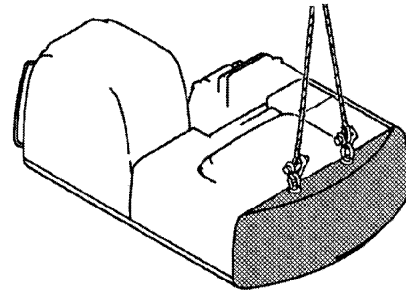

Fig. 11-1 Lifting up counterweight

11.2 REMOVAL

(1) Lifting up counterweight temporarily

Hook wire rope to slinging jig, and lift it and stretch wire rope to the degree where it is providing no slack temporarily.

Weight of counterweight ;

Approx. 3900kg (8600 lbs)

Wire more than $\varnothing 16$ (0.63”) ;

1.5m (5ft) \times 2 pcs.

(2) Removing counterweight

1) Remove four capscrews (C1) M27 \times 300.

 : 41mm

2) Remove shim (C3), (C4), (C5). (Select)

3) Remove counterweight (A1).

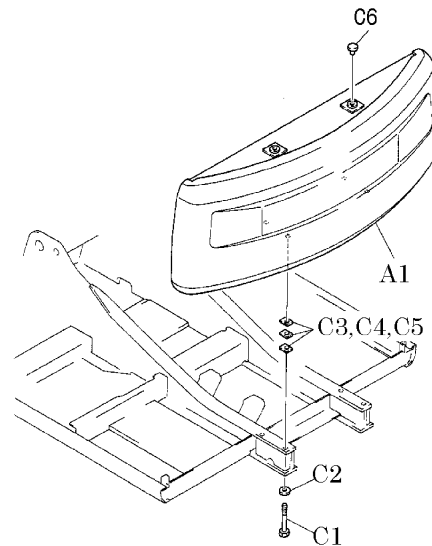

Fig. 11-2 Removing counterweight

11.3 INSTALLATION

(1) Install counterweight in the reverse procedure of removing.

(2) Install shim (C3), (C4), (C5) as it was. (select)

(3) Slings counterweight

Check that the attaching bolts can be screwed in by hand.

(4) Apply Loctite #242 on capscrews (C1), and tighten them with washers (C2).

 : 41mm

Tightening torque : 130kgf-m (940ft-lbs)

(5) Remove slinging tools, and attach plugs (C6).

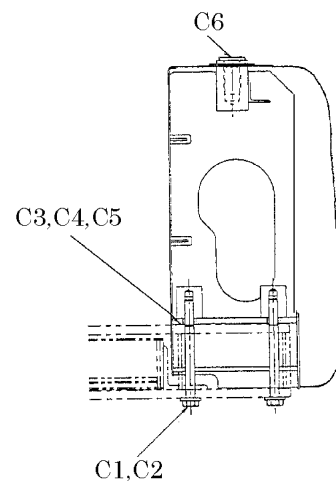



Fig. 11-3 Fastening the counterweight attaching capscrew

16. CONTROL VALVE

16.1 PREPARATION FOR REMOVAL

- (1) Remove guard (12) (Refer to 4. GUARD)
- (2) Install the suction stopper to the hydraulic oil tank.
- (3) Remove the hoses located at the below ports :

 Mark each hose with a port name before removing it.

16.2 REMOVAL

- (1) Remove four capscrews (3) M12 × 35.
 : 19mm
- (2) Remove the control valve with brackets (1), (2)
 Weight : Approx. 162kg (357 lbs)

16.3 INSTALLATION

- (1) Installing is done in the reverse order of remove.
 : 19mm, Apply locktite #262
 Tightening torque : 12.3kgf·m(89ft·lbs)
- (2) Check for oil leakage and operation.

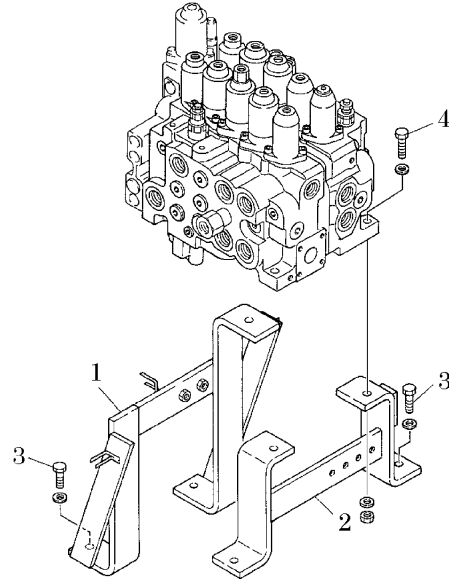



Fig. 16-1 Removing the standard main control valve

This figure shows the control valve with option 1 valve.

Functions	Ports	Ports on upper sides (on machine)	Ports	Functions
Arm variable recirculation Arm in Arm (H) relief valve Boom conflux Swing left Travel left forward	PiS PAa — PB1 PAS PAL	LEFT SIDE ← → RIGHT SIDE 	PA01 — PCB — PAb Drc PLC1 PAC — PAr —	Drain port A01 relief valve P1 bypass cut P1 negative control relief valve Boom up Boom lock drain Boom down lock release Bucket dump Bucket (R) relief valve Main relief valve
Swing motor boost circuit Tank return	T2 T	Ports on rear sides (on machine) REAR SIDE ← → FRONT SIDE 	P1 P2	P1 pump P2 pump

21.3 INSTALLATION

- (1) Installing is done in the reverse order of removing.
- (2) Cleaning mating surfaces of upper frame and swing bearing.
- (3) Apply Loctite #515 to the inside of the capscrews on the contact surface.
- (4) Slinging upper frame
Match marks and install it with three reamer bolts (11) temporarily.

 Confirm the reamer bolt positions referring to Fig. 21-5.

 : 30mm, Tightening torque :
40kgf·m (290ft·lbs)
Apply Loctite #262

- (5) Install swing bearing
Install thirty capscrews (10) M20 × 105.
 : 30mm, Tightening torque :
40kgf·m (290ft·lbs)
Apply Loctite #262

Apply Loctite #515 to the race surface over the whole circumference (hatched) on the inside of capscrew.

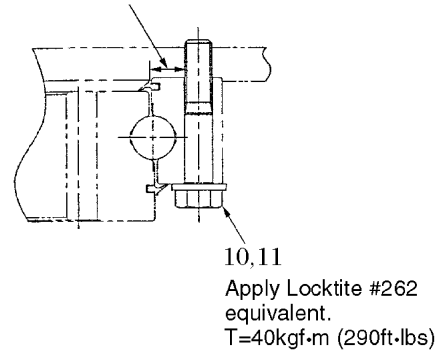

Fig. 21-4 Bearing mount

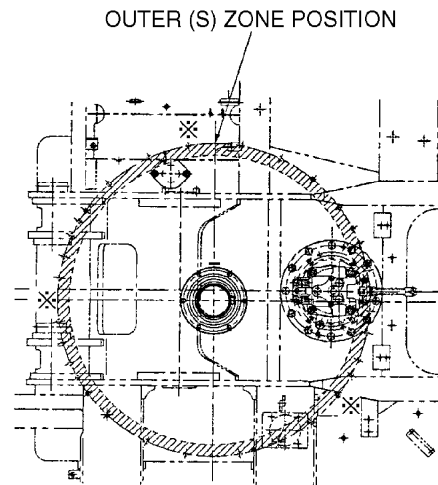

Fig. 21-5 Reamer bolt position (⊗)
Apply Loctite on section specified by slanting lines

12) Remove spline joint

Separate needle bearing (124) and spline joint (114) from valve block (312).

- Do not draw out needle bearings (124) except when their service life has ended.
- Do not loosen nuts (808) (marked ※) of valve block (312) and swash plate support (251) : A set flow rate changes.

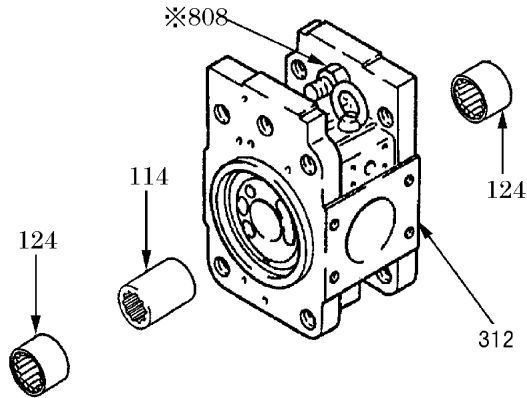

Fig. 1-16 Removing spline joint

(3) Installing procedure

1) Precautions to be exercised in installation

Assembly is a reverse order of disassembly, but notice the following.

1. Repair scored parts at disassembly. Get replacements ready beforehand.
2. Wash parts sufficiently in cleaning oil and dry them with jet air.
3. Do not forget to coat the sliding areas and bearings with clean hydraulic oil.
4. In principle, replace sealing parts such as O rings and oil seals.
5. Tighten socket bolts and plugs to specified torques in this manual, using a torque wrench.
6. Do not mix up front pump parts with rear pump parts.

2) Installing servo piston, etc.

Fit servo piston (532), tilting pin (531), stopper (L) (534) and stopper (S) (535) to pump casing (271).

- When tightening servo piston (532) and tilting pin (531), use a jig so as not to damage the head of the tilting pin and feedback pin (548).
- Coat the screwed part with Loctite #242.

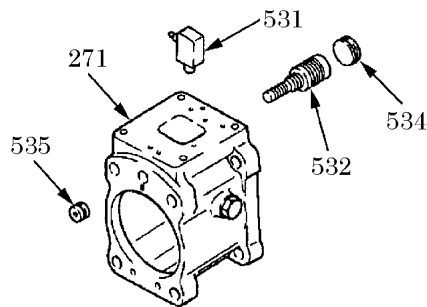

Fig. 1-17 Installing servo piston (532), etc.

3) Installing swash plate support

Attach swash plate support (251) to pump casing (271) by tapping the swash plate support lightly with a plastic hammer (K).

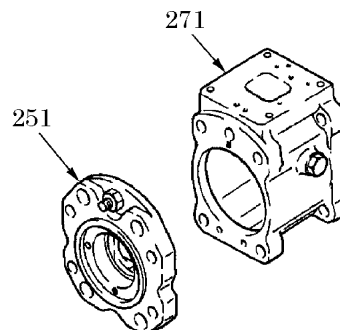

Fig. 1-18 Attaching swash plate support (251)

1.2.2 DISASSEMBLY AND ASSEMBLY

(1) Tools

The right list shows the tools required for remove and install.

(2) Disassembling procedure

1) Selecting a place for disassembly.

- Choose a clean place.
- Spread rubber sheet or cloth on work bench to protect parts from damaging.

2) Cleaning

Remove dust and rust, etc. on regulator surface with wash oil.

3) Remove regulator (See Fig.1-32)

Remove socket bolts (412, 413) and separate the regulator from the pump body.

 : 6mm

4) Remove port plate (See Fig.1-32)

Remove socket bolt (439) and separate the port plate (656).

 : 6mm

5) Remove cover

Remove socket bolts (438) and remove cover (629).

 : 5mm

- The cover is equipped with adjust screws (628, 925), adjust stem (627), lock nut (630), hex nut (801) and set screw (924). Do not loosen those screws and nuts. If they are loosened, preadjusted set pressure and flow values change.

Table 1-4

Tool name	Dimension
Allen wrench	Opposing flats 4,5,6mm
Socket wrench, Wrench with double heads (single head)	
Adjust wrench	Small size (MAX. 36mm)
Screw driver	
Plastic hammer	
Torque wrench	
Plier	For snap ring 2pcs.
Steel bar	Dia. less than 4mm ℓ=100mm (4")
Pincers	
Bolt	M4 About ℓ=50mm (2")

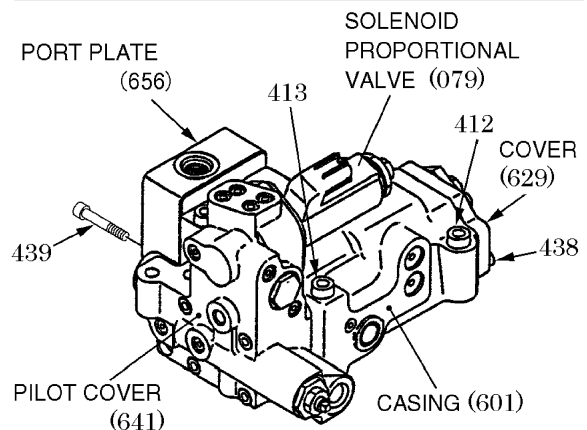

Fig. 1-32 Removing regulator

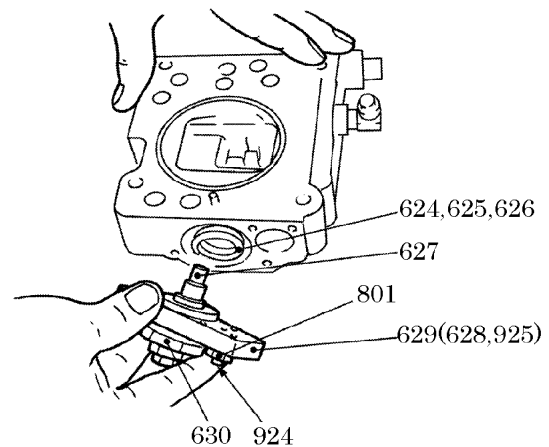



Fig. 1-33 Removing cover (629)

(16) Assembling option valve VBY-147 (OPT1) and VBY-148 (OPT2).

(See See YN24, I - 4-6, Fig.4-6)

1) Tighten plug (P552) with O ring (P562) to casing (P101) and fasten it to the specified torque.

 : 10mm,
Tightening torque :
11~13kgf·m (80~94ft·lbs)

2) Assemble poppet (P512) and spring (P522) to casing (P101) and fasten plug (P551) with O ring (P561) to the specified torque.

 : 12mm,
Tightening torque :
32~36kgf·m (230~260ft·lbs)

3) Put a protective plate (aluminum plate, etc.) in the vise and hold the middle of option spool (P301) in it. Set spring seat (P337), springs (P323), (P324) and stopper (P333) and tighten bolts (P334) to the specified torque.

 : 10mm,
Tightening torque :
1.6~1.8kgf·m (12~13ft·lbs)

-  ● When tightening bolts (P334), coat them with Loctite #262.
- Be careful so as not to distort option spool (P301) by overtightening it in the vise.

4) Assemble the option spool assy in par. 3) into casing (P101).

5) Put O ring (P261) to the spring side of the option spool assy, attach spring cover (P202) to the assy and tighten socket bolts (P271) to the specified torque.

 : 6mm,
Tightening torque :
2.5~3.5kgf·m (18~325ft·lbs)

6) Install spool cover (P204) with O ring (P262) and fasten socket bolt (P271) to the specified torque.

7) Install overload relief valve (P603) to casing (P101) and fasten it to the specified torque.

 : 32mm,
Tightening torque :
7~8kgf·m (51~58ft·lbs)

 Note that the tightening torque differs for VBY-147 and VBY-148.

(17) Assembling negative control relief valve VBY-145, 146

(See See YN24, I - 4-7, Fig. 4-8, 4-9)

1) Assemble negative control relief valve sub into casing (N101).

2) Fit O ring (N561) to plug (N551) and tighten the plug against casing (N101) to the specified torque.

 : 6mm,
Tightening torque :
2.3~2.7kgf·m (17~20ft·lbs)

(10) Remove port plate (111), O ring (122) from casing (101).

(11) Remove bushing (131) from casing (101).

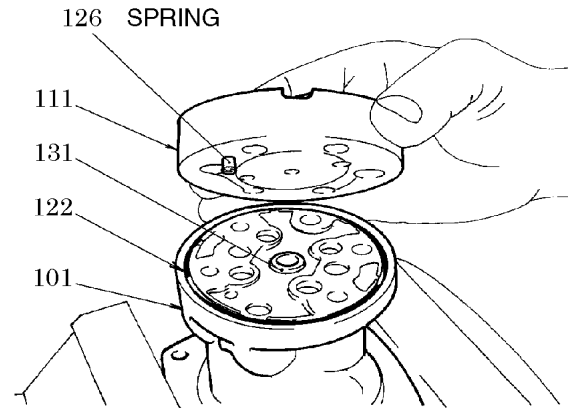

Fig. 3-10 Removing port plate, bushing

(12) Push springs (241-1), (241-2) in the range of that the movement of spring seats (216-1), (216-2) is 7mm (0.276in) or less, and remove spools (201-1), (201-2) through the large hole of seat.

⚠ Never push spring seat (216-1) in 7mm (0.276in) or more. (For ports 1,3)
Never push spring seat (216-2) in 9.4mm (0.370in) or more. (For ports 2,4)

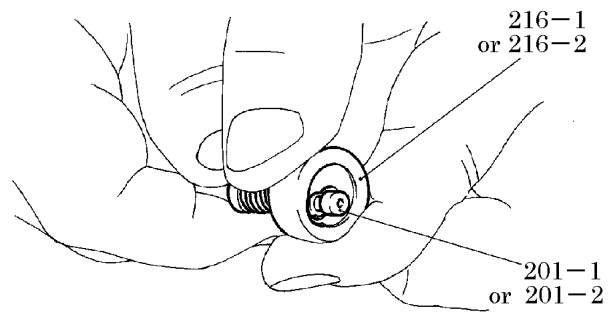

Fig. 3-11 Removing spool (201)

(13) Remove spool (201-1), (201-2), spring seats (216-1), (216-2), spring (241-1), (241-2) and washer (217).

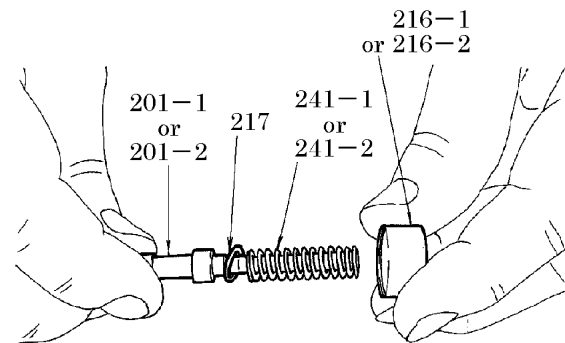

Fig. 3-12 Disassembling pressure reducing valve

(14) Remove spring (246), spring seat (218-1), (218-2) from push rod (212).

(15) Pull out push rod (212) from plug (211).

(16) Remove O ring (214) from plug (211).

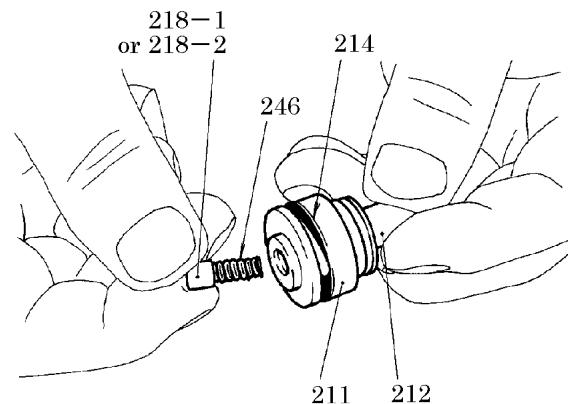



Fig. 3-13 Disassembling push rod

7. Assembly

- Clean and degrease parts before assembly. In particular, clean the body with a nylon brush. Foreign matter intruded into the valve causes functional faults to occur.
- Prepare new seals (O rings and U packings) and coat the surface with hydraulic oil or a thin film of grease.

8. Assembling the shuttle. (See Fig.4-7.)

- (1) Put two balls (36) into body (5).
- (2) Coat the screwed part of seat (2) with Locktite#262 and fit two of them to body (5).

 : 5mm, Tightening torque :
 $1.5 \pm 0.1 \text{ kgf}\cdot\text{m} (11 \pm 0.7 \text{ ft}\cdot\text{lbs})$

- (3) Set O rings (42) to socket plugs (25) and fasten two plugs to body (5).

 : 6mm, Tightening torque :
 $2.5 \pm 0.2 \text{ kgf}\cdot\text{m} (18 \pm 1.4 \text{ ft}\cdot\text{lbs})$

9. Assembling the reducing valve spool assy (See Fig. 4-5.)

- (1) Fix spool (4) in a vise. (Put copper plates against the mouth.) Set washer (29), shims (10), (11), spring (8) and sleeve (18), in that order, and tighten them with four socket flange bolts (27).

 : 3mm, Tightening torque :
 $0.5 \pm 0.1 \text{ kgf}\cdot\text{m} (3.6 \pm 0.7 \text{ ft}\cdot\text{lbs})$

- On that occasion, pair parts with the disassembled parts as sets, before performing assembly work. Incorrect pairing may change the secondary pressure.

10. Assembling the reducing valve (See Fig.4-8.)

- (1) Fit four O rings (38), (40), parallel pins (32) and springs (7) to body (5).
- (2) Fit four reducing valve spool assemblies and stoppers (6). On that occasion, use care as stopper (6) has a direction in which it should be installed: Place it so the concave surface of it faces down (reducing valve spool side).
- (3) Set O rings (41) to socket plugs (24). Fasten three plugs to body (5).

 : 5mm, Tightening torque :
 $1 \pm 0.1 \text{ kgf}\cdot\text{m} (7.2 \pm 0.7 \text{ ft}\cdot\text{lbs})$

11. Assembling the damper (See Fig.4-3.)

- (1) Fit four U packings (37) to cover (15).
 - On that occasion, place the cover so the lip of the U packing faces down (damper chamber side).

- (2) Insert four piston assemblies (44) into cover (15).

- In that case, make sure that each piston is set in the same hole where it was before disassembly.

The performances of the piston are not affected at all if it is placed in any direction on the circumference.

- (3) Fit O ring (39) to guide (17). Install four guides to cover (15).

- Fix the guide in the same hole where it was set before disassembly.

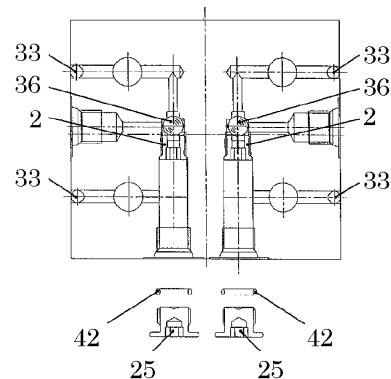

Fig. 4-7 Assembling the shuttle

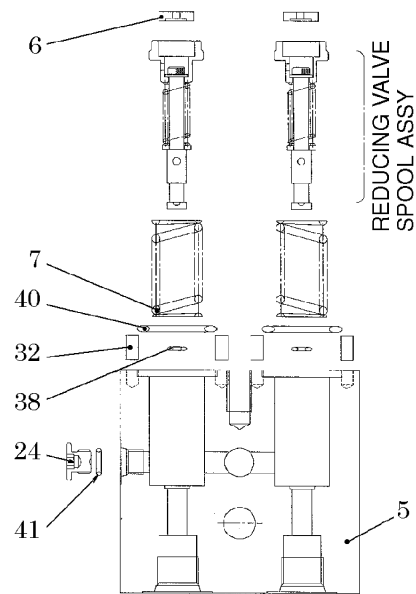

Fig. 4-8 Assembling the reducing valve

- 6) Place casing (301) as shown in Fig. 5-11 and insert shoe plate (124).

On that occasion, the shoe plate does not come off if it is coated with grease.

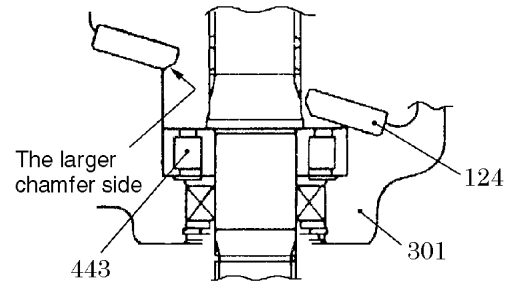

Fig. 5-11 Inserting shoe plate (124)

- 7) Fix spacer (118) and spring to cylinder (111), fit snap ring (438) to it and insert push rod (116) into cylinder (111).

Then mount the spherical bushing (113) with spacer F (117) on the cylinder.

- 8) Place piston sub assy (121, 122) on retainer plate (123).

- 9) Assemble piston sub assy (121, 122) fixed in retainer plate (123) into cylinder (111). Match it to the spline of drive shaft (101) and insert it in place.

On that occasion, drive shaft (101) is easy to be inserted if the phase of spherical bushing (113) is aligned with that of the spline of cylinder (111).

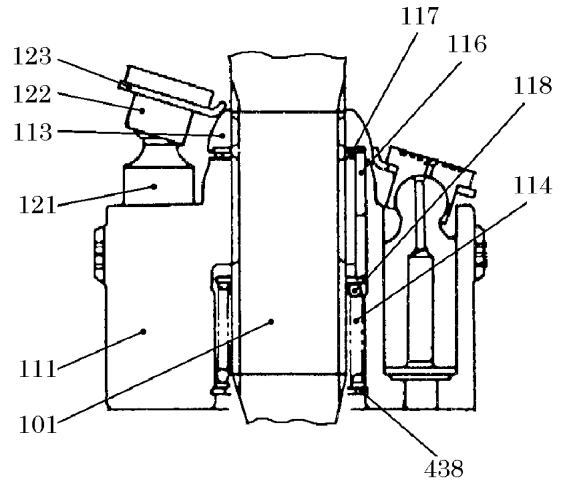

Fig. 5.12 Inserting cylinder assy

- 10) Replace casing (301) with seal cover facing downward and assemble separator plate (743) and friction plate (742) into casing (301), in that order.

Assemble four separator plates and three friction plates.



Assemble the same phases of four slits in the gears of friction plate (742). Assemble four slits in the four claws of separator plate (743) in the position of Fig.5-13.

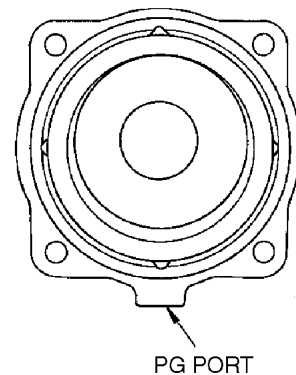

Fig. 5-13 Mounting position of separator plate

6) Installing ring gear (16)

Apply a thin film of sealing compound (Loctite #515) to the matching surface of housing (10) and ring gear (16) and assemble them, aligning the gear teeth and according to the matching marks given.

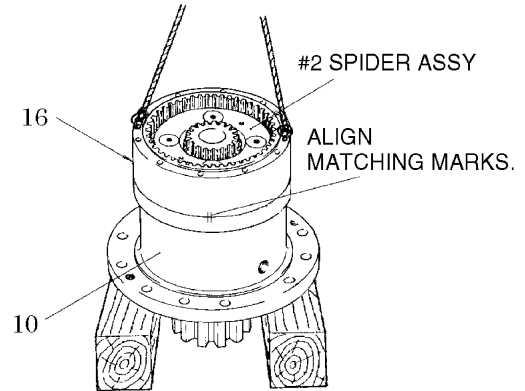



Fig. 5-37 Installing ring gear (16)

7) Installing #1 spider assy

1. Mesh the #1 spider assy with ring gear (16) and set them in place.
2. Mesh #1 sun gear (19) with #1 pinion (26) and set them in place.

8) Fit drain hose (36) and plug (37).

 : 12mm

9) Filling Lube Oil

Fill in 7.5ℓ (2.0gal) of Extreme pressure gear oil SAE90 (API Service Grade GL-4).

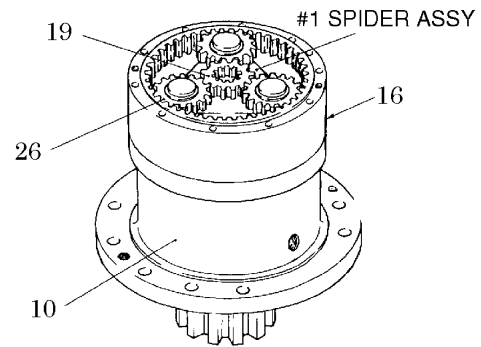



Fig.5-38 Installing #1 spider assy

10) Installing swing motor assy

Attach eye bolts (M12×1.75) in the tapped holes of the swing motor and put a wire sling in them.

Coat the matching surface of ring gear (16) with sealing compound (Loctite #515), insert the spline joint of the swing motor and match the matching marks.

Coat socket bolts (18) with screw lock compound (Three-Bond 1360K) and fasten them.

 : 12mm,

Tightening torque 18.5kgf·m (130ft·lbs)

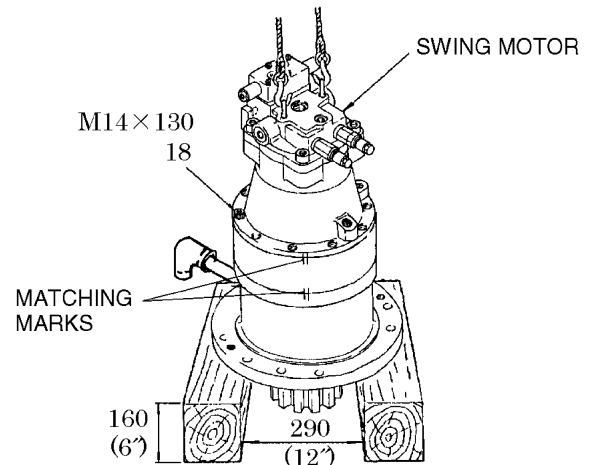



Fig. 5-39 Installing swing motor assy

6.2.4 DISASSEMBLY

The part numbers used in this disassembly procedure correspond to those of a construction drawing in Fig.6-1.

(1) Removing cover

- 1) Mark cover (4) and body (1) with matching marks for convenient reassembly.
- 2) Place a V-block on a work bench, place a swivel joint set on the side, fix it and loosen socket bolt (9) by means of a pipe and wrench. Alternately, the swivel joint may be fixed by holding stem (2) in a vise.

 : 6mm

- 3) Remove cover (4) from body (1) and draw out O ring (7) from cover (4).

(2) Removing thrust plate

Loosen socket bolt (8) fastening thrust plate (3), in the same manner as the removing of the above-mentioned cover.

- When removing thrust plate (3) by fixing body (1), support stem (2) so it may not fall down.

 : 6mm

(3) Removing stem

Place body (1) on a V-block. Put a wooden block against stem (2) via the body so about half of the stem is covered by the wooden block and knock it out using a mallet.

By hitting out the stem over about 1/2 from the body, it can be easily pulled out by hand.

Stem weight : 12kg(26 lbs)

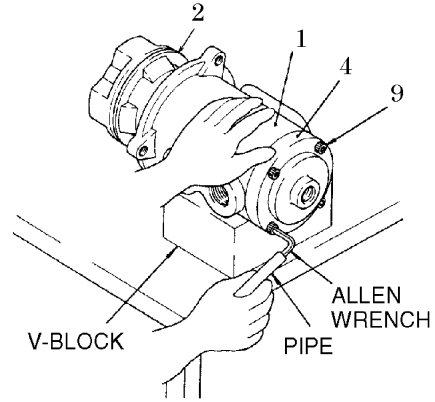

Fig. 6-2 Removing cover (4)

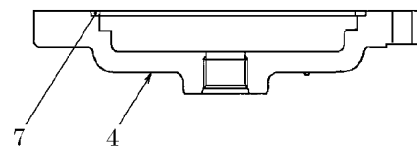

Fig. 6-3 Removing O ring (7)

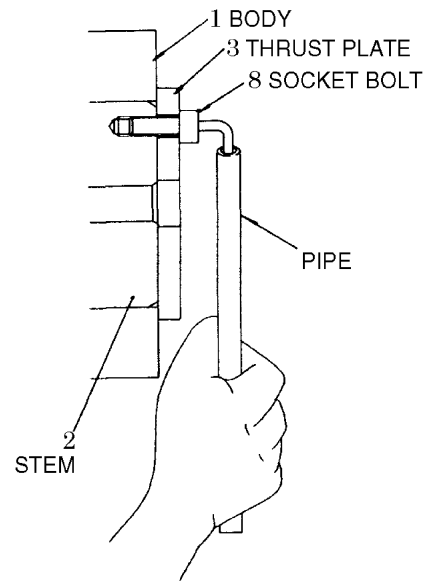

Fig. 6-4 Removing thrust plate (3)

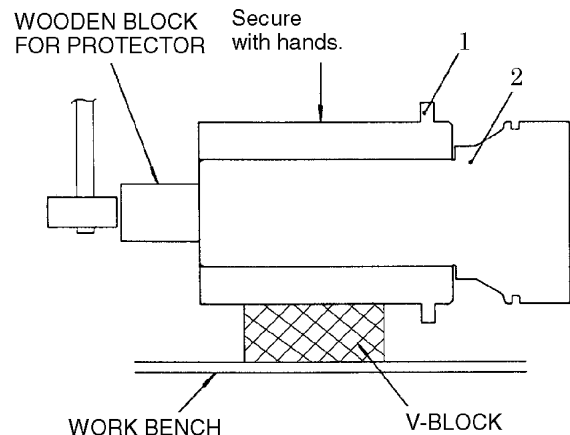

Fig. 6-5 Drawing out stem (2)

CHAPTER 34
TRAVEL SYSTEM
TABLE OF CONTENTS

1. Removal And Installation	
1. Travel System	1-1
2. Crawler	
2.1 Removing Crawler	1-1
2.2 Installing	1-2
2.3 Construction	1-3
2.4 Maintenance Standards	1-4
2.5 Tools and Jigs	1-4
3. Upper Roller	
3.1 Upper roller Assembly 1-5	
3.2 Removing	1-5
3.3 Installing	1-5
3.4 Construction	1-6
3.5 Disassembly and Assembly	1-6
3.6 Maintenance Standard	1-9
3.7 tools and Jigs	1-10
4. Lower Roller (Track Roller)	
4.1 Lower Roller Assembly	1-11
4.2 Removing	1-11
4.3 Installing	1-11
4.4 Construction	1-12
4.5 Disassembly and Assembly	1-12
4.6 Maintenance Standard	1-16
4.7 Tools and Jigs	1-17
5. Front Idler	
5.1 Front Idler (Idler Adjustment Assembly)	1-18
5.2 Removing	1-18
5.3 Idler Assembly	1-19
5.4 Idler Adjustment Assembly	1-23
6. Sprocket	
6.1 Removing	1-27
6.2 Installing	1-27
6.3 Maintenance Standard	1-18
6.4 Tools and Jigs	1-28
7. Travel Motor	
7. 1 Travel Motor	1-30
7.2 Removing	1-30
7.3 Installing	1-31
8. Swing Bearing	
8.1 Swing Bearing Assembly	1-32
8.2 Removing	1-32
8.3 Installing	1-33
8.4 Construction	1-33
8.5 Disassembly and Assembly	1-33
8.6 Maintenance Standard	1-34

3.6 MAINTENANCE STANDARD

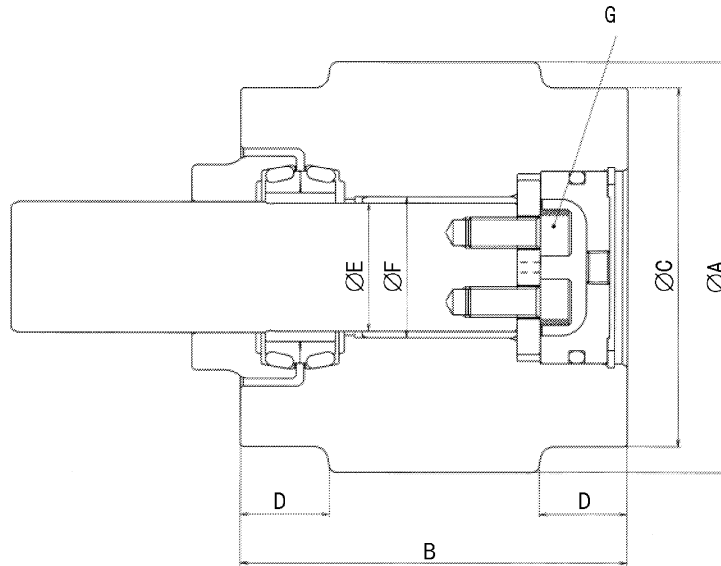

Table 3-1

Unit : mm (in)

No.	ITEM	STANDARD VALUE		REPAIRABLE LEVEL	SERVICE LIMIT	REMEDY	
A	Dia.	Ø160 (6.30)		-	-	Replace	
B	Width	150 (5.91)		-	-		
C	Tread dia.	Ø140 (5.51)		Ø130 (5.12)	Ø128 (5.04)		
D	Tread width	33 (1.30)		-	-		
E	Clearance between shaft and bushing	Basic dimension	Tolerance		Fit	Fit	Replace bushing.
		Ø50 (1.96850)	Shaft	+/- 0.025 +/- 0.050 +/- 0.00098 +/- 0.00197	Clearance 0.7 (0.028)	Clearance 1.0 (0.039)	
F	Interference between roller and bushing	Ø55 (2.16535)	Hole	+/- 0.030 0 (+/- 0.00118 0	Interference 0	Clearance 0.01 (0.0004)	
G	Tightening torque of socket bolt	11.7kgf·m(85ft·lbs)					
	Oil	Engine oil API grade CD #30, 50cc (3.05cu·in)				Refill	
	Roller rotation	Roller rotates smoothly by hand.				Reassembly	

5.3 IDLER ASSY

5.3.1 CONSTRUCTION

IDLER ASSY			YN52D00009F1
No.	NAME	Q' T	REMARKS
		Y	
1	IDLER	1	YN52D01006P1
2	BUSHING	2	
3	COLLAR	2	YN52D01011P1
4	FLOATING SEAL	2	
5	PIN	2	
6	SHAFT	1	
7	O RING	2	1A G70
8	PLUG	2	PT1/8

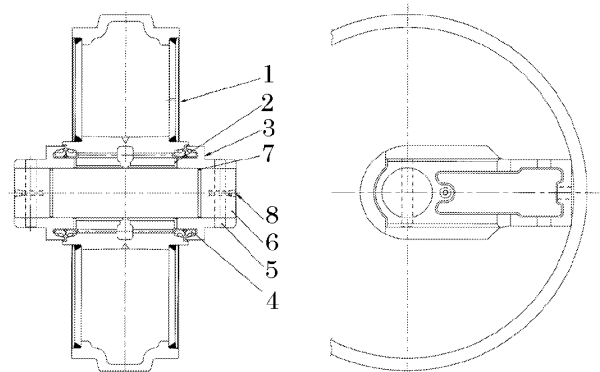



Fig. 5-4 Idler assy

5.3.2 REMOVING AND INSTALLING

(1) Removing

1) Drain oil

Remove plug (8) on the side of collar (3) to drain.

 : 5mm

2) Removing pin (5)

Apply pin push bar (jig R) to the top of pin, and push out striking bar (jig R) lightly by hammer.

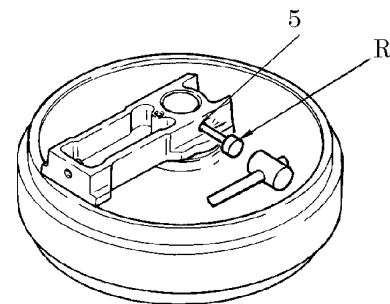

Fig. 5-5 Removing pin (5)

3) Removing collar (3)

Put idler (1) on repair stand (U), apply push-out jig (S) on shaft (6), push out shaft (6) with collar (3), then remove collar (3).

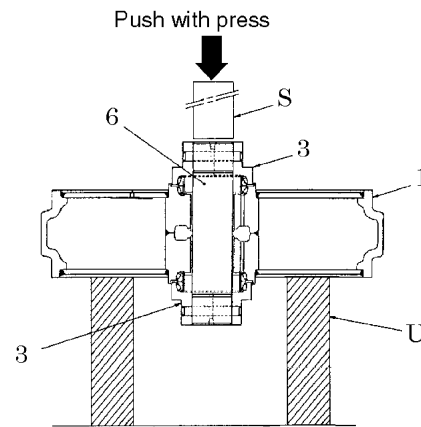

Fig. 5-6 Removing collar (3)

4) Removing collar (3) from shaft (6)

If removal of collar (3) on the opposite side is required, turn over front idler and proceed with the procedure described in Par. 3).

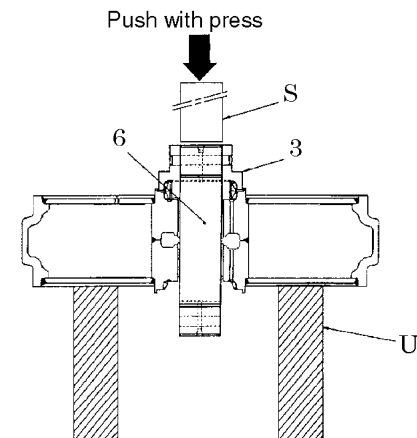

Fig. 5-7 Removing collar (3)

2) Disassembling the motor

- || Place the motor shaft level and remove all bolts (31) except two vertically diagonal ones.

└ : 14mm

- ┆ Loosen two remaining bolts slowly at the same time.

- @ Remove rear cover (2) and spring (28), taking care so cylinder block (3) does not come off with rear cover (2).

- ⚠ In that case, do not drop valve plate (8), brake spring (28) or O ring (43).

- ‰ Remove valve plate (8) so cylinder block (3) does come off together.

- ⚠ Put a matching mark on valve plate (8) and rear cover (2) so they are reassembled correctly. (so the face and the back are not reversed.)

- ‰ Push in cylinder block (3), using removed bolt (31) in the holding-down metal so the cylinder block is not damaged, till the inner race of rear bearing (30) sticks out.

- || Remove the inner race of rear bearing (30) by putting the gear (bearing) puller in the inner race.

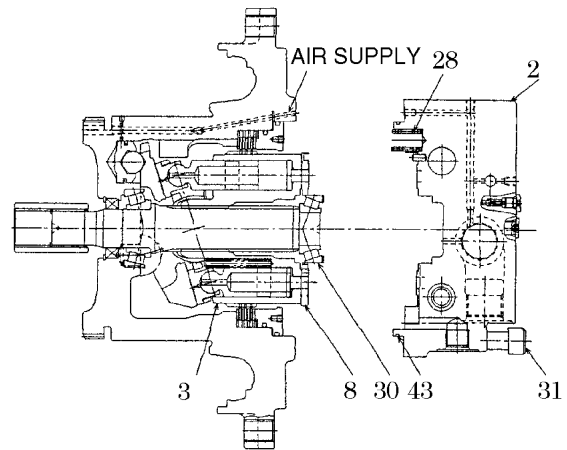

Fig.1-4 Removing the rear cover

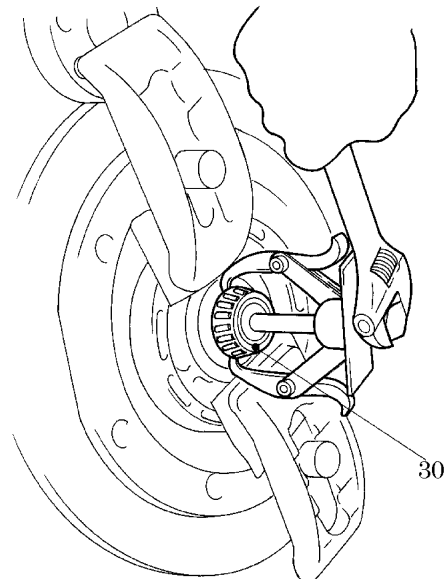

Fig.1-5 Removing the rear bearing

1.6 TRAVEL MOTOR TROUBLESHOOTING

Troubleshooting cause and remedy

The following are corrective actions to be taken in case the motor is in trouble.

1.6.1 GENERAL PRECAUTIONS

(1) Cautions to be exercised before work

Before proceeding to work, determine the nature of abnormality and think if a similar symptom occurred before.

Think once again if the fault really comes from the motor.

(2) Beware of dust.

Many faults are caused by dust. Therefore, take dustproofing measures at disassembly.

(3) Handling parts

Handle parts with due care, particularly the moving portions, so as not to damage the moving parts.

(4) Handle O rings so as not to score the seat surfaces.

At removal, replacing O rings with new ones is recommended.

1.6.2 TROUBLESHOOTING CAUSE AND REMEDY

(1) Motor does not start.

Symptom	Cause	Remedy
Pressure does not rise.	Built-in relief valve is out of order.	Repair or replace relief valve.
Pressure rises.	<ol style="list-style-type: none"> 1. Negative brake is not released. (Orifice in release pressure path is clogged.) 2. Negative brake is not released. (The spool is assembled the other way in terms of right and left.) 3. Friction plate or separator plate in Negative brake is stuck. 4. Negative brake piston in mechanical brake section is stuck. 5. Sliding area is seized. 6. Spool malfunctions (Spool is stuck.) (The hole in the restrictor valve is clogged.) 	<ol style="list-style-type: none"> 1. Check if orifice is not clogged. Clean or replace orifice. 2. Assemble the spool in correct orientation. 3. Replace friction plate and separator plate. 4. Recondition O. D. of brake piston or replace brake piston. 5. Repair or replace piston, shoe, shoe plate, cylinder block and valve plate. 6. Correct or replace

(2) Motor does not start powerfully.

Symptom	Cause	Remedy
A set pressure is normal, but brake release lags behind.	Spool malfunctions (Spool is stuck.)	Correct or replace



SHOP MANUAL - SECTION 4

**E215
CRAWLER EXCAVATORS**

— TROUBLESHOOTING —

2. TROUBLESHOOTING ; MECHATRO CONTROL

Actuator Operating condition		Electric											Hydraulic																									
		Hi pressure sensor (P1)	Hi pressure sensor (P2)	Low pressure sensor	Arm variable recirculation solenoid proportional valve	P2 bypass cut solenoid proportional valve	Travel straight solenoid proportional valve	P1 bypass cut solenoid proportional valve	Swing P/B solenoid valve	Attachment power boost	Travel 1-2speed solenoid valve	Safety look lever solenoid valve	P1 pump solenoid proportional valve	P2 Pump solenoid proportional valve	Control valve							Motor			Cylinder		Other											
		S E — 22	S E — 23	S E — 1-10	P S V — A	P S V — B	P S V — C	P S V — D	S V — 1	S V — 2	S V — 3	S V — 4	P S V — P1	P S V — P2	Boom	Arm	Bucket	Swing	Travel right	Travel left	P1 bypass cut valve	P2 bypass cut valve	Travel straight valve	Boom conflux valve	Arm conflux valve	Arm variable recirculation valve	Right travel motor	Left travel motor	Swing motor	Boom	Arm	Bucket	Boom lock valve	Arm lock valve				
		22	23	1-10	A	B	C	D	1	2	3	4	P1	P2	Boom	Arm	Bucket	Swing	Travel right	Travel left	P1 bypass cut valve	P2 bypass cut valve	Travel straight valve	Boom conflux valve	Arm conflux valve	Arm variable recirculation valve	Right travel motor	Left travel motor	Swing motor	Boom	Arm	Bucket	Boom lock valve	Arm lock valve				
Independent operation	Boom raising inching operation	○	○	○				○	○		○	○	○																									
	Boom raising full lever operation	○	○	○		○			○	○		○	○	○								○		○														
	Boom lowering operation	○	○	○						○		○	○	○																							○	
	Arm out inching operation	○	○	○					○			○	○		○																							
	Arm out full lever operation	○	○	○						○	○		○	○								○			○													
	Arm in inching operation	○	○	○	○				○	○		○	○		○												○											○
	Arm in full lever operation	○	○	○	○				○	○		○	○		○												○											○
	Heavy duty arm in full lever operation	○	○	○	○		○	○	○	○		○	○		○						○		○			○											○	
	Bucket digging	○	○	○							○		○																								○	
	Bucket dump	○	○	○									○																								○	
	Swing operation	○	○	○										○																○								
	Travel LH / RH operation (1st. speed)	○	○	○								○	○															○	○									
Travel LH / RH operation (2nd speed)	○	○	○							○	○	○																○	○									

(3)-1

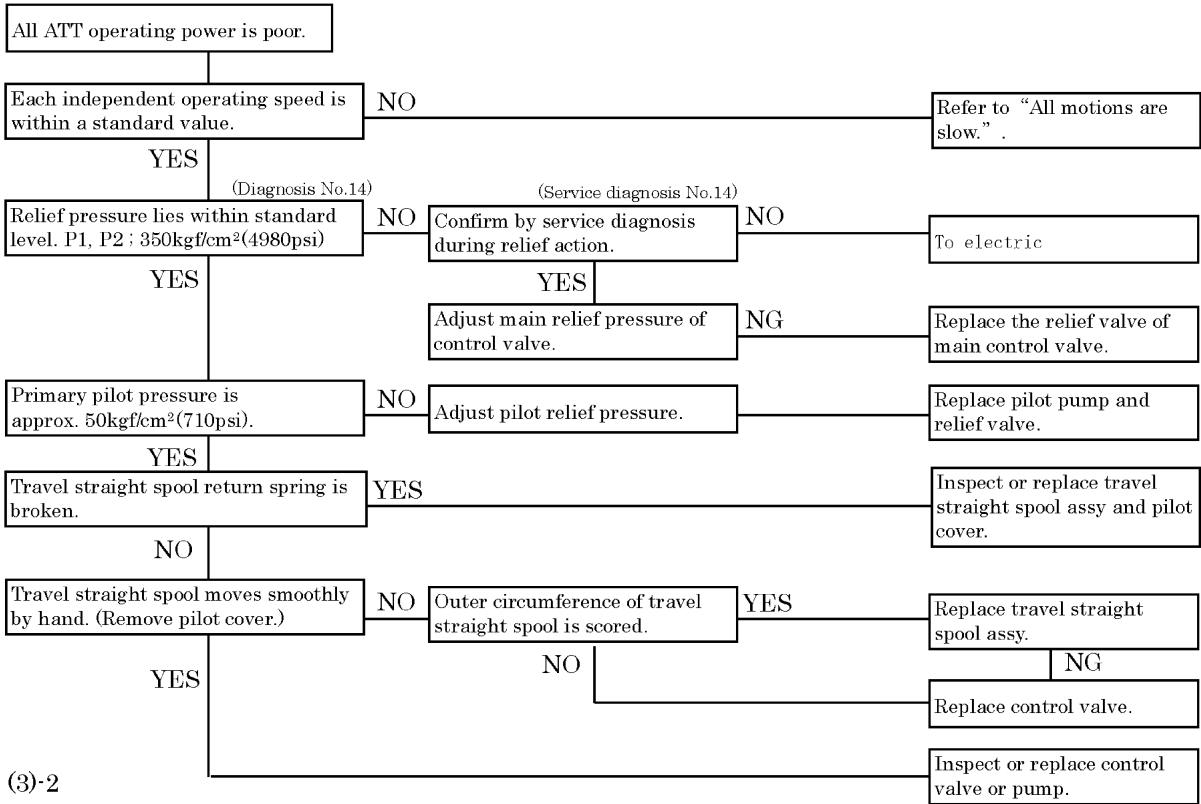

(3)-2

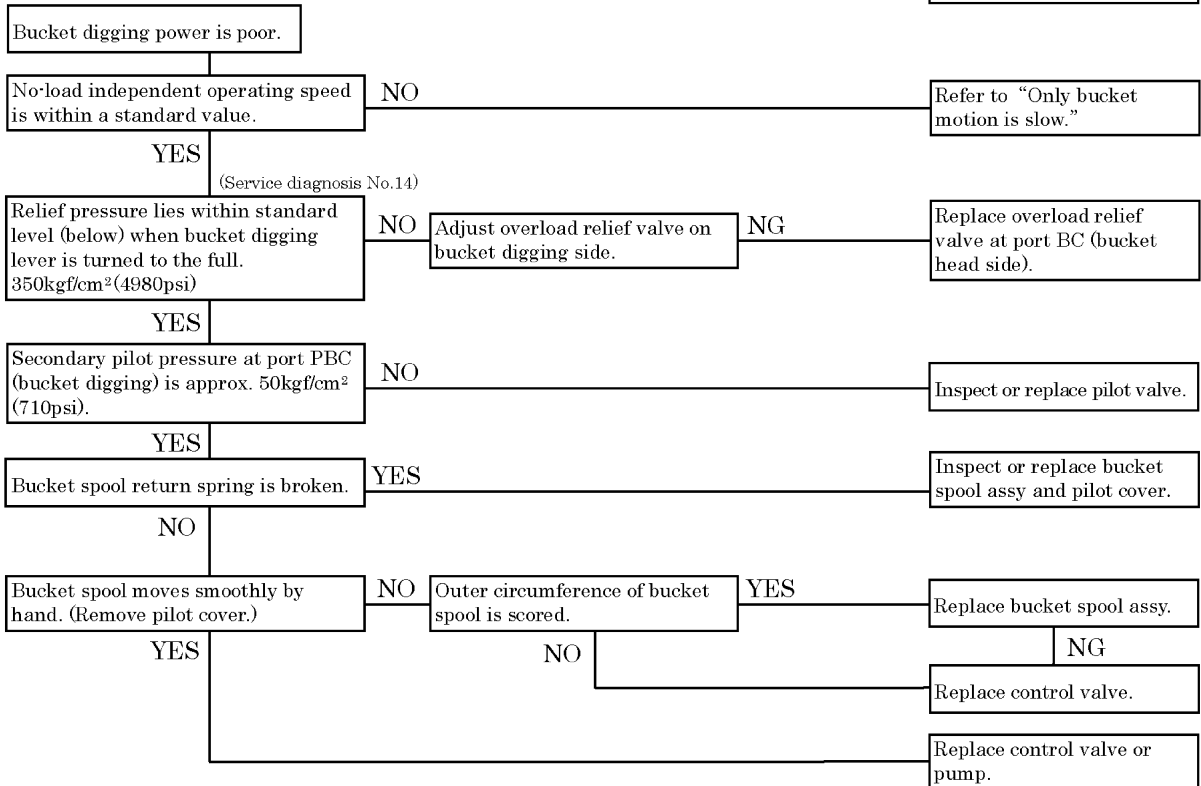

(8)-1

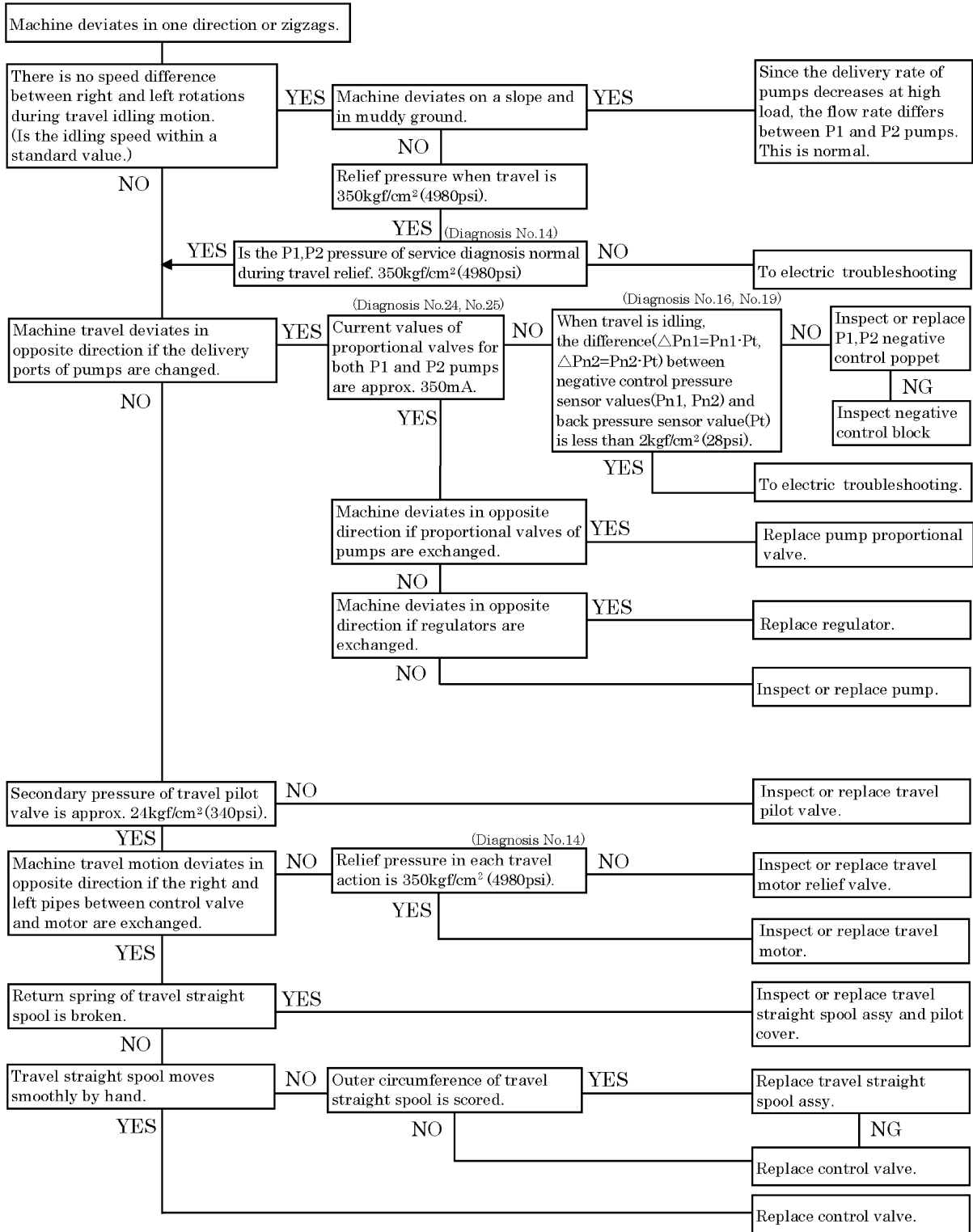

CHAPTER 43
TROUBLESHOOTING (ELECTRICAL SYSTEM)
TABLE OF CONTENTS

1. TROUBLE DIAGNOSIS: ELECTRICAL SYSTEM	
1.1 Diagnosis	1
1.2 Hydraulic Pressure Measurement	1
2. TROUBLESHOOTING	
1.1 No Motion	7
1.2 Movement When Lever is at Neutral	7
2.1 All movement (motion) slow	8
2.2 Bucket Motion Slow	9
2.3 Boom Raise Speed Slow	10
2.4 Machine Motion Slow Except Boom Raise or Arm Out	11
2.5 Arm in Motion Slow	12
2.6 Arm Out Operation Slow	13
3.1 Attachment Operation Power Poor	14
3.2 Bucket Operation Power Poor	14
3.3 Boom Raise Operation Power Poor	14
3.4 Arm in Operation Power Poor	15
4.1 Fine Operation of Bucket Digging Cannot be Performed	16
4.2 Fine Operation of Boom Raise Cannot be Performed	17
4.3 Fine Operation of Arm In and Out are Not Possible	18
5.0 Travel 1-2 Speeds cannot be Changed	19
6.0 Travel Independent is Low	20
8.1 Machine Does Not Travel Straight	21
8.2 Deviation of Travel	22
9.0 Machine Drifts on a Slope	22
10.0 Swing Operation Inoperable	22
12.0 Swing Speed Slow (When 2P Connector is Disconnected)	23
13.1 Swing Cannot be Held on Slope	24

(2)-2

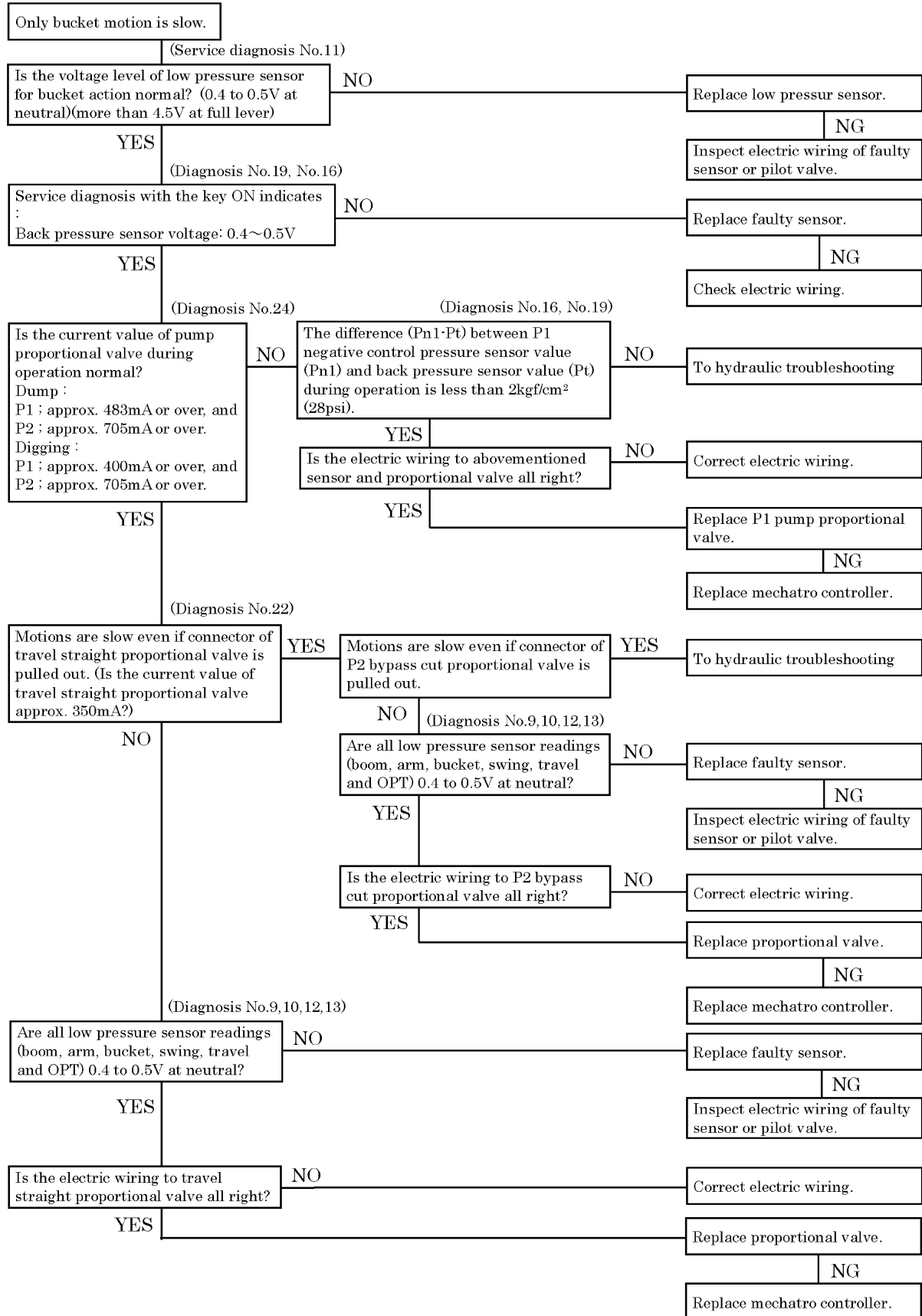

(5)

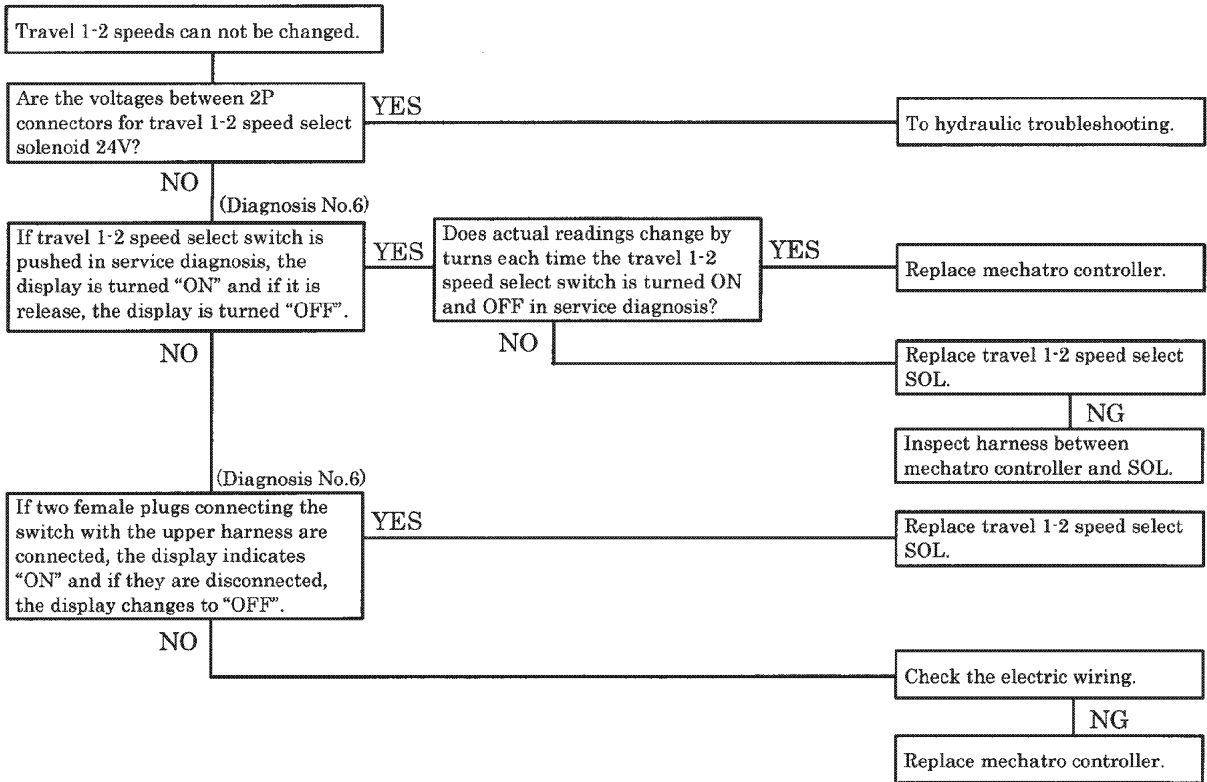

**SECTION 5
ENGINE**

TABLE OF CONTENTS

CHAPTER 51 - ENGINE

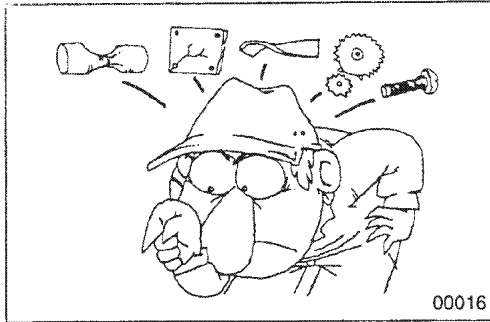

00016

On disassembly, visually inspect all parts for wear and tear, cracks, damage, deformation, degradation, rust, corrosion, smoothness in rotation, fatigue, clogging and any other possible defect.

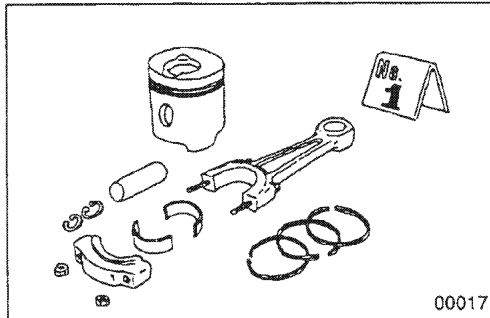

00017

Put alignment marks on part combinations before disassembly and arrange the disassembled parts neatly. This will help avoid mismatching of the parts later.

Put the alignment marks, punch marks, etc. where performance and appearance will not be affected.

Cover the area left open after removal of parts to keep it free from dust.

CAUTION ⚠

- Take care to avoid mixing up numerous parts, similar parts, left and right, etc.
- Keep new parts for replacement and original (removed) parts separate.

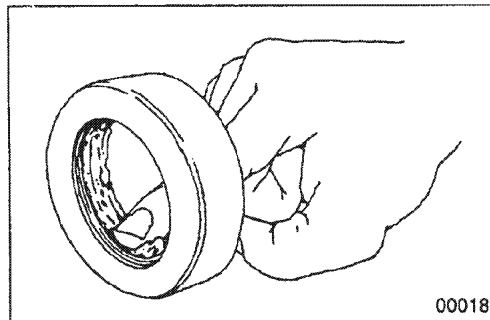

00018

Apply the specified oil or grease to U-packings, oil seals, dust seals and bearings during assembly.

CAUTION ⚠

Use only the specified oil, grease, etc. for lubricant. Remove the excess immediately after application with a piece of rag.

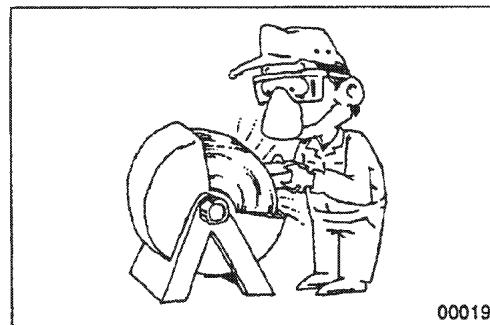

00019

Wear goggles when using a grinder or welder. Pay full attention to safety by wearing gloves when necessary. Watch out for sharp edges, etc. that might injure your hands or fingers.

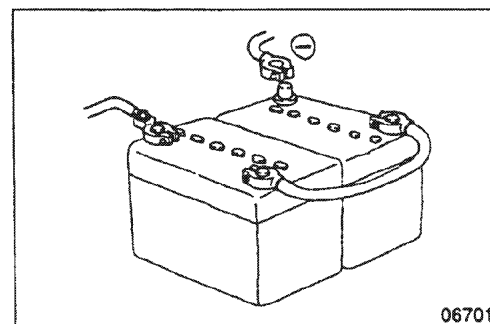

06701

Before carrying out maintenance work on the electric system, disconnect the negative terminals of the batteries.

TROUBLESHOOTING

Symptoms	Possible causes		Remarks
	Low power output	Abnormal engine noise	
	<input type="checkbox"/>	<input type="checkbox"/>	Gr 12
Incorrect oil viscosity	<input type="checkbox"/>	<input type="checkbox"/>	
Incorrect/defective fuel	<input type="checkbox"/>	<input type="checkbox"/>	
Incorrect valve clearance	<input type="checkbox"/>	<input type="checkbox"/>	
Defective cylinder head gasket	<input type="checkbox"/>	<input type="checkbox"/>	
Worn valve/valve seat, and carbon deposits	<input type="checkbox"/>	<input type="checkbox"/>	
Weakened valve spring	<input type="checkbox"/>	<input type="checkbox"/>	
Worn/damaged piston ring(s)	<input type="checkbox"/>	<input type="checkbox"/>	
Worn/damaged piston ring groove(s)	<input type="checkbox"/>	<input type="checkbox"/>	
Incorrect injection timing	<input type="checkbox"/>	<input type="checkbox"/>	Gr 13
Defective injection pump	<input type="checkbox"/>	<input type="checkbox"/>	Gr 13
Defective cooling system	<input type="checkbox"/>	<input type="checkbox"/>	Gr 14
Defective injection nozzle(s)	<input type="checkbox"/>	<input type="checkbox"/>	Gr 13
Air trapped in fuel system	<input type="checkbox"/>	<input type="checkbox"/>	Gr 13
Clogged air cleaner	<input type="checkbox"/>	<input type="checkbox"/>	Gr 15
Defective turbocharger	<input type="checkbox"/>	<input type="checkbox"/>	Gr 15
Incorrectly fitted pipe(s)/hose(s)	<input type="checkbox"/>	<input type="checkbox"/>	
Injection pump, alternator, or other auxiliary device(s) defective/incorrectly fitted	<input type="checkbox"/>	<input type="checkbox"/>	Gr 13, 54
Loose/damaged V-belt	<input type="checkbox"/>	<input type="checkbox"/>	Gr 14
Incorrectly fitted crankshaft pulley	<input type="checkbox"/>	<input type="checkbox"/>	
Defective air cleaner or muffler	<input type="checkbox"/>	<input type="checkbox"/>	Gr 15
Defective valve spring(s)	<input type="checkbox"/>	<input type="checkbox"/>	
Defective rocker shaft and bracket	<input type="checkbox"/>	<input type="checkbox"/>	
Incorrect lubrication of rocker shaft bracket	<input type="checkbox"/>	<input type="checkbox"/>	
Incorrect backlash in timing gears	<input type="checkbox"/>	<input type="checkbox"/>	
Incorrect lubrication of timing gear peripheries and idler shafts	<input type="checkbox"/>	<input type="checkbox"/>	
Defective injection nozzle spray condition	<input type="checkbox"/>	<input type="checkbox"/>	Gr 13
Worn connecting rod small end bushing and piston pin	<input type="checkbox"/>	<input type="checkbox"/>	
Worn/damaged crankshaft pin and connecting rod big end bearing	<input type="checkbox"/>	<input type="checkbox"/>	
Worn/damaged crankshaft journal and main bearing	<input type="checkbox"/>	<input type="checkbox"/>	
Excessive end play in crankshaft and camshaft	<input type="checkbox"/>	<input type="checkbox"/>	
Worn tappet(s) and camshaft	<input type="checkbox"/>	<input type="checkbox"/>	

Service standards

Unit: m m)

Location	Maintenance item		Standard value (Basic diameter in [])	Limit	Remedy
4	Outer valve spring	Free length	60.84	57.8	Replace
		Installed load (at 47.25 installed length)	240 ± 12 N {24.5 ± 1.2 kgf}	205 N {20.8 kgf}	
		Squareness	—	2.5	
5	Inner valve spring	Free length	55.07	52.1	Replace
		Installed load (at 40.3 installed length)	93 ± 4.4 N {9.5 ± 0.45 kgf}	79 N {8.1 kgf}	
		Squareness	—	2	
7	Inlet valve	Stem outside diameter	φ 8.96 to 8.97	φ 8.85	Replace
		Sinkage from cylinder head bottom surface	0.75 to 1.25	1.5	Inspect every location
		Valve margin	1.5	1.2	Reface or replace
		Seat angle	45° ± 1.5'	—	Correct
7, 17	Inlet valve stem-to-valve guide clearance		[9] 0.04 to 0.06	0.15	Replace
8	Exhaust valve	Stem outside diameter	φ 8.93 to 8.94	φ 8.85	Replace
		Sinkage from cylinder head bottom surface	0.75 to 1.25	1.7	Inspect every location
		Valve margin	1.5	1.2	Reface or replace
		Seat angle	45° ± 1.5'	—	Correct
8, 18	Exhaust valve stem-to-valve guide clearance		[9] 0.07 to 0.1	0.2	Replace
19	Inlet valve seat width		2 ± 0.2	2.8	Correct or replace
20	Exhaust valve seat width		2 ± 0.2	2.8	Correct or replace
23	Cylinder head	Bottom surface distortion	0.05 or less	0.2	Correct or replace
		Height from top to bottom surface	95 ± 0.1	94.6	Replace

① Tightening torques

Unit: N · m {kgf · m}

Location	Parts to be tightened	Tightening torque	Remarks
11	Glow plug	15 to 20 {1.5 to 2.0}	—
13	Bolt (nozzle bridge installation)	25 {2.5}	—

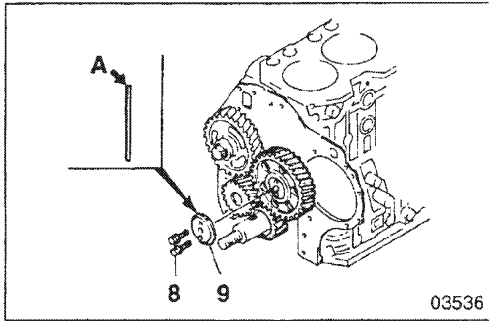

9 Installing thrust plate

A: Chamfered end

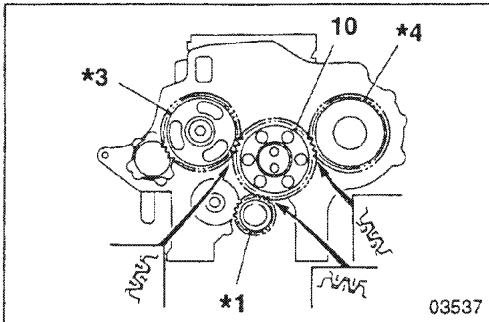

10 Installing idler gear assembly

- Fit the idler gear assembly **10** such that the alignment marks (“1”, “3”, and “4”) on the idler gear are aligned with those on the gears with which it mates.

- *1: Crankshaft gear
- *3: Camshaft gear
- *4: Injection pump gear

NOTE

Align the gear alignment marks with pistons No. 1 and 6 in their top-dead-center positions.

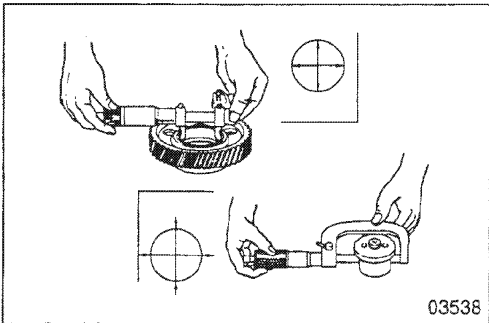

10 13 Idler shaft and idler gear bushing

[Inspection]

If the clearance exceeds the specified limit, replace the defective part(s).

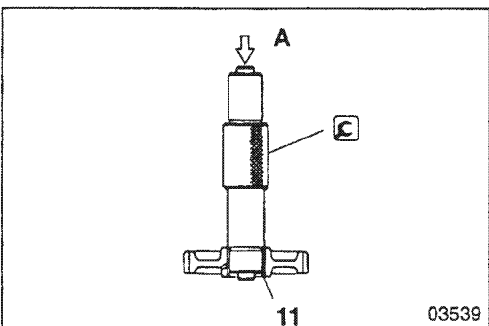

Idler gear bushing

[Removal]

A: Press

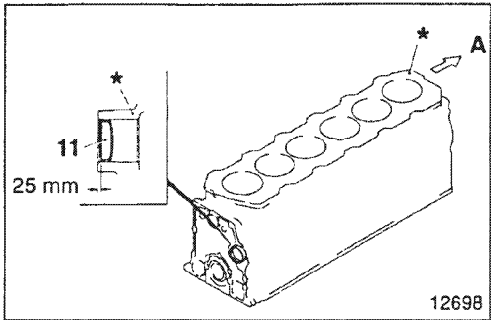

11 Installing sealing cap

Tap the sealing cap 11 into the crankcase * to the specified depth.

A: Front of engine

☒ Special tools

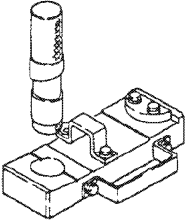
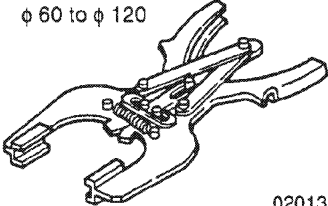
Location	Tool name and shape	Part No.	Application
3	Connecting Rod Bushing Puller Kit 	MH062225 02015	Removing and installing connecting rod bushings
5 to 7	Piston Ring Tool $\phi 60$ to $\phi 120$ 	MH060014 02013	Removing and installing piston rings

◆ Service procedure

☒ ☒ Piston and connecting rod

If the clearance exceeds the specified limit, replace the defective part(s).

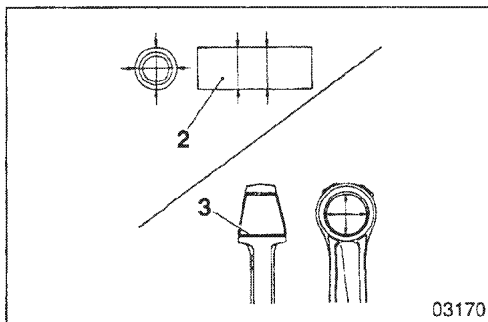

☒ Connecting rod bushing

Replace the connecting rod bushing 3 using the ☒ Connecting Rod Bushing Puller Kit. This consists of the following parts:

- A: Base
- B: Bracket
- C: Puller
- D: Collar
- E: Plate
- F: Collar
- G: Nut

[Removal]

- Remove the bearing (if fitted) from the big end of the connecting rod 4.
- Mount the connecting rod 4 on the base A and lock it in position with the bracket B and plate E.
- Position the puller C and collar D as shown in the illustration. Then, slowly apply pressure of approximately 49 kN (5,000 kgf) until the connecting rod bushing 3 is pressed out.

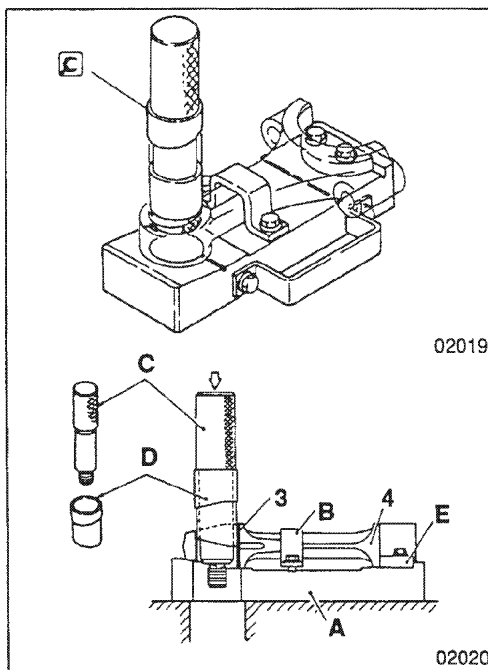

Service standards

Unit: mm

Location	Maintenance item		Standard value (Basic diameter in [])	Limit	Remedy	
—	Crankshaft end play		0.10 to 0.26	0.4	Inspect	
2, 18	Main bearing	Oil clearance	[78] 0.03 to 0.09	0.15	Replace	
		Span when free	—	Less than 82.5		
17	Crankshaft	Bend	0.02 or less	0.05	Replace	
		Pin and journal	Roundness	0.01 or less	0.03	Correct or replace
			Cylindricity	0.006 or less	—	
23	Distortion of crankcase top surface		0.07 or less	0.2	Correct or replace	

① Tightening torques

Unit: N·m {kgf·m}

Location	Parts to be tightened	Tightening torque	Remarks
1	Main bearing cap mounting bolt	59 {6} + 90° ± 5°	Wet

🔧 Lubricants and sealants

Location	Points of application	Kinds	Quantity
9	Side seal mounting surfaces of rear main bearing	Threebond 1207C	As required
2, 18	Main bearing inside surfaces	Engine oil	As required
11	Side seal ends and grooves	Threebond 1207C	As required

Lubrication System (Oil Flow)

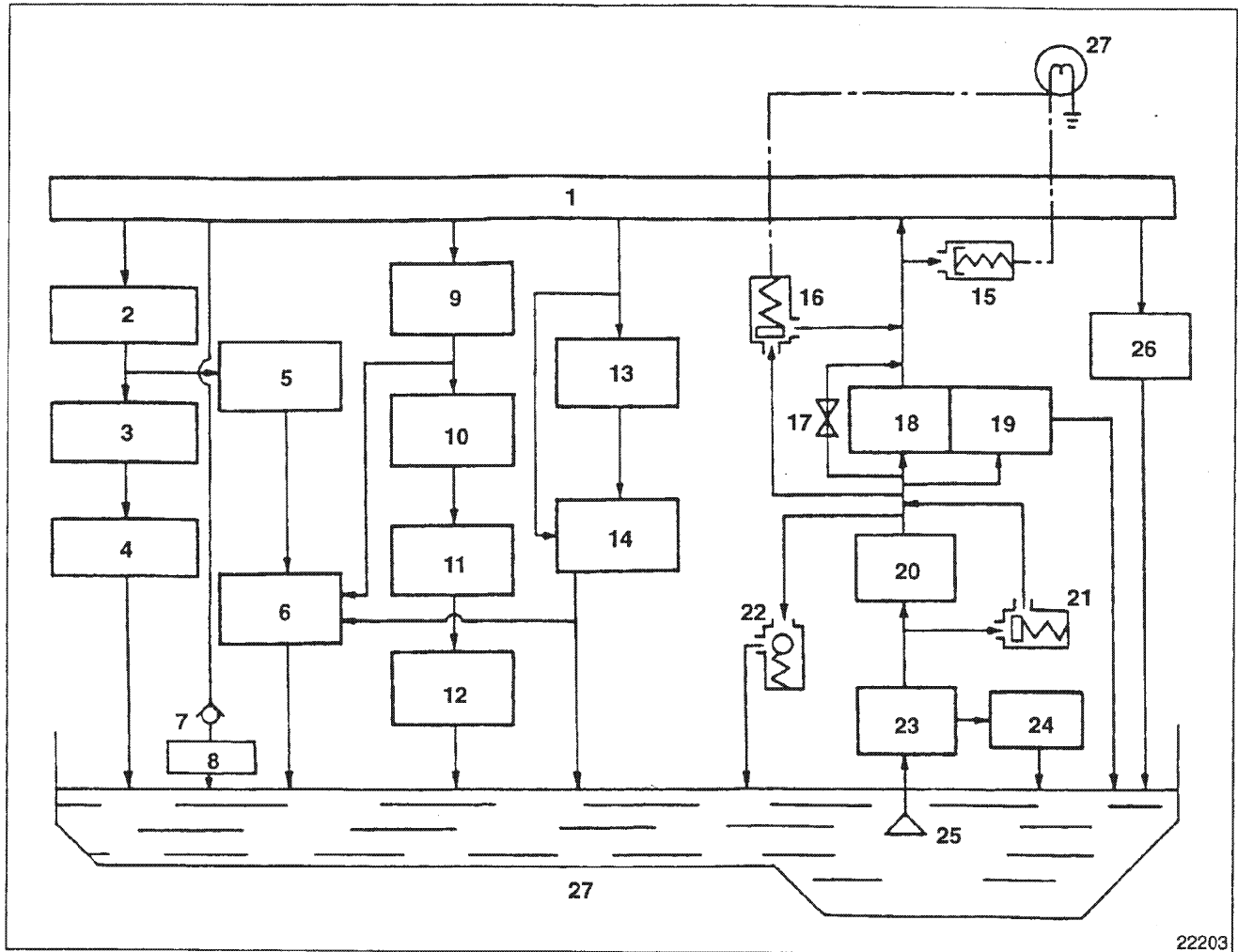

- | | |
|---------------------------|--|
| 1 Main oil gallery | 15 Engine oil pressure switch |
| 2 Crankshaft main bearing | 16 Engine oil bypass alarm switch |
| 3 Connecting rod bearing | 17 Bypass valve (Built-in within oil filter) |
| 4 Connecting rod bushing | 18 Full-flow filter element |
| 5 Idler gear bushing | 19 Bypass filter element |
| 6 Timing gear | 20 Oil cooler |
| 7 Check valve for oil jet | 21 Bypass valve |
| 8 Piston | 22 Regulator valve |
| 9 Camshaft bushing | 23 Oil pump |
| 10 Rocker bushing | 24 Relief valve (Built-in within oil pump) |
| 11 Push rod | 25 Oil strainer |
| 12 Tappet | 26 Turbocharger |
| 13 Injection pump | 27 Warning lamp |
| 14 Automatic timer | 28 Oil pan |

MEMO

GROUP 13 FUEL AND ENGINE CONTROL

SPECIFICATIONS	2
STRUCTURE AND OPERATION	3
TROUBLESHOOTING	10
ON-VEHICLE INSPECTION AND ADJUSTMENT	
• Checking and Adjusting Injection Timing	14
• Checking and Adjusting Minimum and Maximum No-load Speeds	17
FUEL FILTER	18
INJECTION PUMP	20
INJECTION NOZZLE	24

Possible causes		Symptoms											
		Engine will not start	Engine difficult to start	Engine knocks	Unstable engine output	Insufficient engine output	Engine maximum speed too high	Unstable engine idling	Engine stops soon after starting	Engine does not reach maximum speed	Engine will not stop	Accelerator pedal too stiff	Defective fuel supply
Governor	Insufficient full-load stopper position					○							
	Weak governor spring					○				○			
	Incorrectly adjusted control lever				○	○				○			
	Flyweights not operating effectively						○						
	Weak idling spring							○					
	Bent links							○					
	Excessive friction or play in links							○					
	Loose round nut							○					
	Poorly adjusted idling set bolt							○					
	Defective sliding action in control lever											○	
	Stop mechanism damaged										○		
Injection nozzles	Sticky needle valve	○											
	Valve opening pressure too low	○								○			
	Blocked injection orifice	○		○		○		○		○			
	Poor airtightness in nozzle	○		○		○		○		○			
	Valve opening pressure too high			○									
	Broken spring				○	○							
	Defective sliding action in needle valve				○								
	Defective valve opening pressure				○								
	Weakness/deterioration in spring								○				
Fuel filter	Filter (and/or secondary filter) clogged	○			○			○	○				
Fuel tank empty		○											
Fuel pipes blocked and/or fuel leaking from connections		○											
Air or water in fuel system		○			○			○	○				
Low-quality fuel in use			○	○		○		○					
Cracked fuel pipe												○	
Leaky fuel tank												○	
Incorrect oil viscosity	📖 Gr. 12		○										
Incorrect valve clearance	📖 Gr. 11		○					○					
Defective head gasket	📖 Gr. 11		○					○					
Wear and/or carbon deposits on valve and valve seat	📖 Gr. 11		○					○					
Weakness/deterioration in valve spring	📖 Gr. 11		○					○					
Worn/damaged piston ring(s)	📖 Gr. 11		○					○					

Tightening torques

Unit: N · m {kgf · m}

Location	Parts to be tightened	Tightening torque	Remarks
6	Fuel leak-off pipe eye bolt	19 to 29 {2 to 3}	—
1, 3	Fuel hose eye bolt	17 {1.75}	—
5	Injection pipe union nut	24 {2.5}	—
8	Oil pipe eye bolt	8 to 15 {0.8 to 1.5}	—

Lubricant

Location	Points of application	Type	Quantity
12	O-ring	Engine oil	—

Special tools

Unit: mm

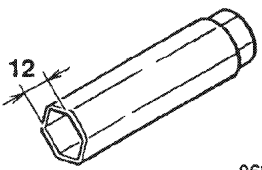
Location	Tool name and shape	Part No.	Application
19	Socket Wrench  06876	31391-14100	Removal and fitting of injection pump assembly

Service procedure

19 Installing injection pump assembly

[Removal]

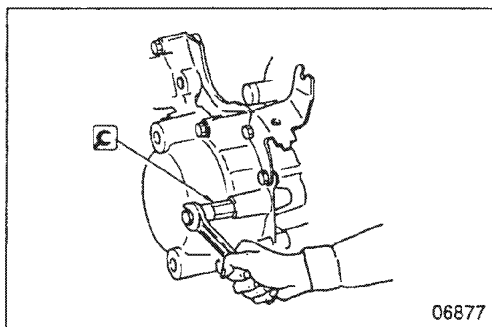

Water Pump

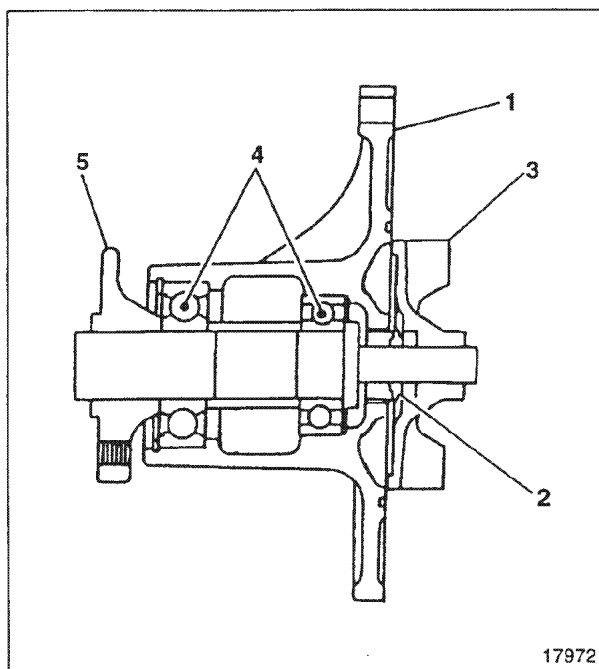

- 1 Case
- 2 Unit seal
- 3 Impeller
- 4 Unit bearing
- 5 Flange

Thermostat

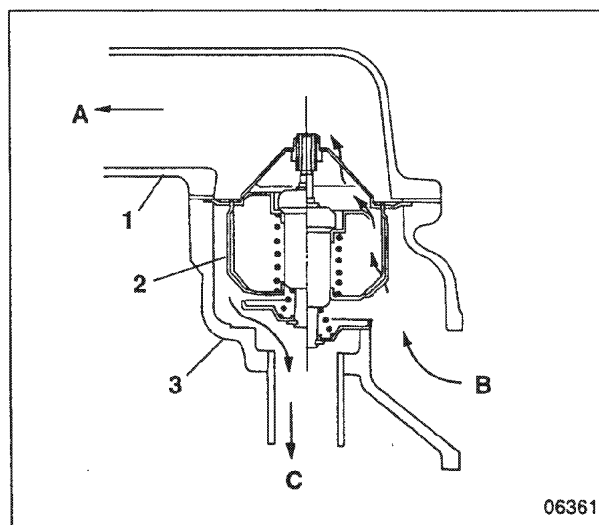

- 1 Thermostat cover
- 2 Thermostat
- 3 Thermostat case

- A: To radiator
- B: From cylinder head
- C: To water pump

Thermostat 2 is a bottom bypass type that uses wax-charged pellets as its regulating element. As the wax changes from solid to liquid in line with temperature increases, the total wax volume changes. As a result, the position of the valve, changed by the coolant temperature, regulates the flow of coolant to the radiator and water pump (bypass side) and controls the coolant temperature.

CLICK HERE TO **DOWNLOAD** THE COMPLETE MANUAL

- Thank you very much for reading the preview of the manual.
- You can download the complete manual from: www.heydownloads.com by clicking the link below



- Please note: If there is no response to CLICKING the link, please download this PDF first and then click on it.

CLICK HERE TO **DOWNLOAD** THE COMPLETE MANUAL