



# NEW HOLLAND

# D150

Workshop  
Manual

 **NEW HOLLAND**

PROVEN PERFORMANCE

CLICK HERE TO **DOWNLOAD** THE COMPLETE MANUAL

- Thank you very much for reading the preview of the manual.
- You can download the complete manual from: [www.heydownloads.com](http://www.heydownloads.com) by clicking the link below



- Please note: If there is no response to CLICKING the link, please download this PDF first and then click on it.

CLICK HERE TO **DOWNLOAD** THE COMPLETE MANUAL

## SAFETY RULES

ling etc.). Do the same when parking for prolonged periods of time to avoid accidental or unauthorised starting.

- Never lower attachments or tools other than seated in operator's seat. Sound horn. Make sure area near the attachment is clear. Lower the attachment slowly. **DO NOT USE FLOAT POSITION** of hydraulic system.
- Place master switch in **OFF**, securely block the machine and lock it every time you leave it unattended. Return keys to authorised security. Heed all shut-down operations of the Operation and Maintenance Instruction Manual are followed.

## MAINTENANCE

### GENERALITIES

- Before operating or performing any intervention on the machine:
  - read carefully all the rules contained by this Manual;
  - read and obey all safety related plates and instructions located on the machine.
- Do not allow unauthorised personnel to perform any maintenance operation. Do not perform maintenance operation without prior authorisation. Follow all recommended maintenance and service procedures.
- Keep operator's compartment free of all loose objects that are not properly secured.
- Do not wear rings, wrist watches, jewellery, loose or hanging apparels, such as ties, torn clothing, scarves, unbuttoned or unzipped jackets that can catch on moving parts. Wear proper safety equipment as recommended for the job. Examples: hard hat, heavy gloves, ear protection, safety glasses or goggles, reflector vests, respirator. Consult your employer for specific safety equipment requirements.
- Do not use controls or hoses as hand holds when climbing on or off machine. Hoses and controls are movable and do not provide a solid support. Also, controls may be inadvertently moved causing accidental machine or equipment movement.
- Do not jump on or off the machine. Keep two hands and one foot, or two feet and one hand in contact with step grab rails and handles at all times.
- Do not perform any service operation on the machine with a person seated in the operator's compartment, unless he is an authorised operator co-operating in the operation to be performed.
- Keep operator's compartment, stepping points, grab-rails and handles clear of foreign objects, oil, grease, mud or snow accumulation to minimise the danger of slipping or stumbling. Clean mud or grease from shoes before attempting to mount or operate the machine.
- Keep shoes free of mud or grease before climbing or driving the machine.
- Never attempt to operate the machine or its tools from any position other than seated in the operator's seat.
- When maintenance operations require moving hydraulically operated attachments by means of machine's hydraulic system remember that all manoeuvres must be made only when seated in the operator's seat. Before starting machine or moving attachment or tools, set brakes, sound horn and call for an all clear. Raise attachment slowly.
- Always block booms or parts of the machine which must be raised to perform interventions under them with external devices. Do not allow persons to move into the vicinities nor standing under equipment not being blocked. Unless you are totally sure about your safety, avoid staying under raised equipment, even in case it is blocked.
- Do not place the body, limbs or fingers into sharp articulation uncontrolled openings of the machine and without proper protections, unless they are blocked in a safe manner.
- Never perform interventions with engine running, except as called for in a Manual. Do not wear loose clothing or jewellery near moving parts.
- When servicing or maintenance require access to areas that cannot be reached from the ground, use a ladder or step platform that meet local and national regulations, to reach the service point. If such ladder or platform are not available, use the machine hand holds and steps as provided. Perform all service or maintenance carefully.
- Shop and/or field service platforms or ladders must be constructed and maintained in accordance with local and national regulations.
- Disconnect batteries and tag all controls according to current regulations to warn that work is in progress. Block machine and all attachments that must be raised according to current regulations.
- Due to the presence of flammable fluids, never check or fill fuel tanks, batteries, nor use starting fluid near lighted smoking materials or open flames.
- Brakes are inoperative when manually released for servicing. Provisions must be made to maintain control of the machine by blocking or other means.

**COLDSTARTING (Optional)**

Upon request, a cold starting device facilitating the starting of the machine at particularly low temperatures is available.

**AUXILIARY APPLICATIONS**

Some of the equipment described and illustrated in this Manual is provided in determined markets to satisfy specific requirements.

Additional devices and special applications can be provided upon request, in agreement with the Sales Organisation. Some accessories upon request are listed here below:

Air conditioner, Cold starting, Blade: HS or folding HS for LGP version, HSU or PAT, Ripper, 1 kg fire extinguisher, Diagnostics, Forest Rops (sweeps), Outer sound suppression, 550 mm shoes.

**MAIN DIMENSIONS AND WEIGHTS**

TYPE OF BLADE	Blade width mm (in)	Blade width mm (in)	Blade capacity SAE J1265 cu m (cu yd)	Tilt mm (in)	Pitch	Digging depth mm (in)	Blade max. lift mm (in)	Width with blade mm (in)	Weight with blade kg (lb)
(HS)	3180 (125.19)	1100 (43.34)	3.10 (4.0)	550 (21.6)	±10°	406 (16.0)	1105 (43.5)	4750 (187.0)	14.811 (*) (32.650)
Semi-U (HSU)	3180 (125.19)	1320 (52)	4.12 (5.36)	550 (21.6)	±6°	480 (18.9)	1105 (43.5)	5025 (197.7)	15.011 (*) (33.095)
STD PAT	3200 (126)	1100 (43.34)	3.15 (4.05)	450 (17.7)	±5°	490 (19.30)	950 (37.4)	4950 (194.9)	14.915 (*) (32.280)
XLT PAT	3200 (126)	1100 (43.34)	3.15 (4.05)	450 (17.7)	±5°	490 (19.30)	950 (37.4)	5315 (209.28)	15.677 (*) (34.560)
LGP PAT	4000 (157.5)	1000 (39.4)	3.15 (4.05)	550 (21.6)	±5°	590 (21.66)	900 (35.43)	5315 (209.28)	16.810 (**) (37.060)

\* Are included in the weight: cab, operator, blade and cylinders, lubricants, coolant and 10% fuel, with 500 mm (20 in).

\*\* Are included in the weight: cab, operator, blade and cylinders, lubricants, coolant and 10% fuel, with 800 mm (32 in).

	MACHINE BASE mm (in)	SHOES mm (in)		WEIGHT kg (lb)		GROUND BEARING AREA cm <sup>2</sup> (in <sup>2</sup> )		PRESSURE ON GROUND kPa	
STD BD (HSU)	2550 (87.7)	500 (19.5)	550 (21.6)	15.011 (33.095)	15.126 (33.277)	25.500	28.050	57.7	52.9
STD PAT	2550 (87.7)	500 (19.5)	550 (21.6)	14.915 (32.280)	15.030 (33.065)	25.500	28.050	57.4	52.6
XLT PAT	2985 (116.4)	500 (19.5)	550 (21.6)	15.677 (34.560)	15.805 (34.770)	29.850	32.835	51.5	47.2
LGP PAT	2985 (116.4)	800 (31.50)		16.810 (37.060)		47.760		34.5	

## TABLES OF TECHNICAL DATA

<b>HYDRAULIC SYSTEM</b>	Model		A11V075	
	Max. displacement	c <sup>3</sup> /rev (in <sup>3</sup> /rev)	75 (4.6)	
	Pump speed at maximum engine speed	rpm	2000	
	Pump max. delivery	lt/min (gpm)	150 (39.6)	
	Min displacement	c <sup>3</sup> /rev (in <sup>3</sup> /rev)	15 (0.9)	
	Discharge valve setting	bar (psi)	30±2 (435±29)	
	<b>Control valve</b>			
	Closed centre, flow partition, 4-spool or 5-spool for PAT version with piloted discharge valve.			
	Brand			Rexroth
	Model			5M6 - 15
	1 <sup>st</sup> spool:			
	- Ripper (raising, lowering control)	lt/min (gpm)		120/150 (31.7/39.6)
	2 <sup>nd</sup> spool:			
- Blade tilt (left, right)	lt/min (gpm)		50/70 (13.2/18.5)	
3 <sup>rd</sup> spool:				
- Blade (raising/lowering /floating control)	lt/min (gpm)		150 (39.6)	
4 <sup>th</sup> spool:				
- Angle	lt/min (gpm)		150 (39.6)	
5 <sup>th</sup> spool:				
- Steering hydraulic motor	lt/min (gpm)		150 (39.6)	
<b>Pilot valve</b>				
Single lever for 2 <sup>nd</sup> and 3 <sup>rd</sup> spool + button.				
Brand			Rexroth	
Model			5THF6	
<b>Auxiliary lever</b>				
Single lever for auxiliary spool.				
Brand			Rexroth	
Model			2TH6	
<b>Lift cylinder</b>				
Blade (HS/HSU)				
2 w/ quick drop valves and stroke limiting valves				
Bore	mm (in)		80 (3.1)	
Diameter of rod	mm (in)		45 (1.8)	
Stroke	mm (in)		1185 (46.6)	
<b>Lift cylinder</b>				
Blade (PAT).				
Bore	mm (in)		90 (3.5)	
Diameter of rod	mm (in)		50 (1.9)	
Stroke	mm (in)		826 (32.5)	
<b>Tilt (Bulldozer blade)</b>				
Bore	mm (in)		125 (4.9)	
Diameter of rod	mm (in)		63 (2.5)	
Stroke	mm (in)		140 (5.5)	

### RECOMMANDATIONS FOR THE DISASSEMBLY AND REASSEMBLY OF GROUPS

The following information, of a general type, have the purpose of facilitating the disassembly and reassembly of groups.

Thus please read and heed them carefully when performing the work.

### CLEANING

After disconnecting the electrical system, clean accurately all the parts to be disassembled, preferably with a jet of steam.

In many repair or service shops caustic compounds are used to eliminate traces of grease, dirt, paint and remains of seals etc. from the parts. These compounds are very useful and effective when properly used, but can cause serious damages to certain materials.

Materials such as aluminium, rubber, fibres sintered bronze and alloying agents are sensitive to all highly concentrated caustic compounds.

Some heat exchangers are built with aluminium fins. To clean them both internally and externally these parts the use of solvents not reacting with aluminium is recommended.

### DISASSEMBLY

It is always recommended for any intervention on the engine or other groups removed from the machine, use the appropriate supporting rigs.

Always make available boxes and containers capable of holding small parts removed. Take particular care that machined surfaces of various parts are resting, after the removal, on wooden blocks or shelves.

When disassembling similar parts, such as valve tappets etc. are placed in appropriate containers, so that the same installation sequence is re-established.

### ASSEMBLY

Clean accurately all components to assemble as described in the various paragraph of the manual.

The use of special tools illustrated in the manual is recommended.

**Note** – *For the applications of sealing compounds please comply with the instructions prescribed on the various commercial products.*





TROUBLE	PROBABLE CAUSE	TOOLS REQUIRED	TEST	SOLUTION
<b>High transmission oil pressure at all engine speeds.</b>	Pressure relief valve seized open.			Eliminate seizure.
<b>High transmission oil temperature.</b>	Transmission oil level low.	Instruction Manual.	Check level on dipstick.	Top-up with prescribed oil to correct level.
	Transmission heat exchanger clogged keeps the safety valve open.		Measure temperature differential between inlet and outlet of heat exchanger. With a clogged unit, the differential is marginal.	Clean or replace the heat exchanger.
	Operation pressure low.		Measure operating pressure of transmission.	Refer to remedies for low oil pressure fault.
	Clutch discs burnt, seized with clutches disengaged.			Replace defective components.
<b>Transmission oil is normal, but the machine moves only at high engine speed.</b>	Oil pump delivery insufficient.			Test pump.

Using an appropriate punch and a soft metal hammer, pull-out the pump drive shafts from the bearings.

**⚠ WARNING**

It is dangerous hitting hardened steel parts with tools different from hammers made of mild steel or non ferrous metals. When these components are remove or installed, always wear safety glasses with side shields, heavy gloves etc., to reduce the chances of injuries.

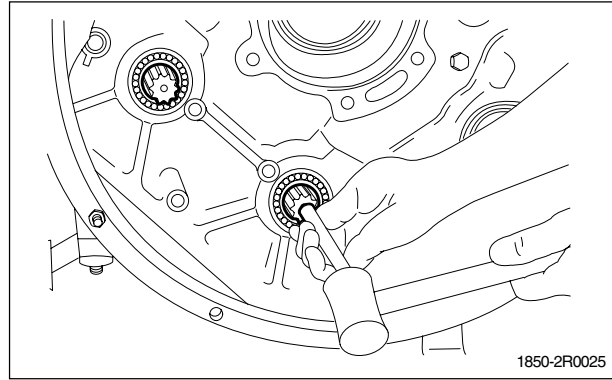

**Fig. 2-25**

Pull-out the bearings and spacers from the housing.

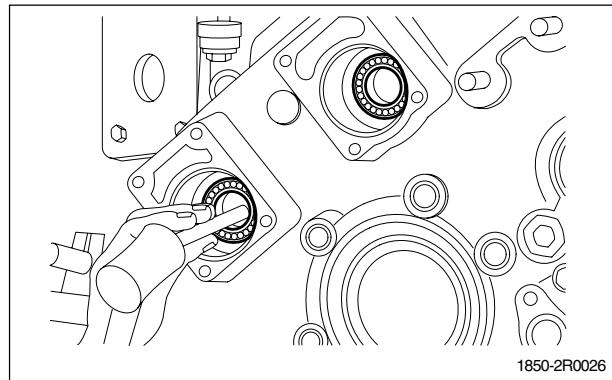

**Fig. 2-26**

Remove the equipment pump drive shaft circlip.

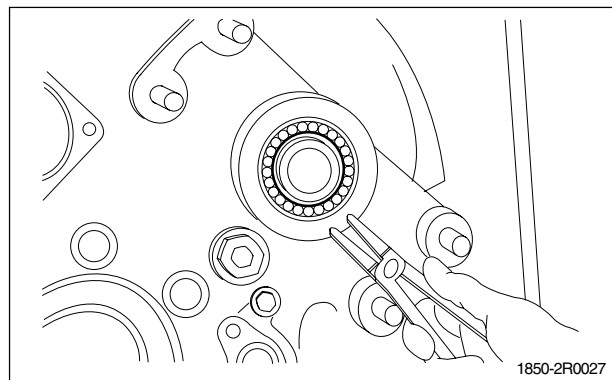

**Fig. 2-27**

Pull-out the shaft and bearing from the housing.

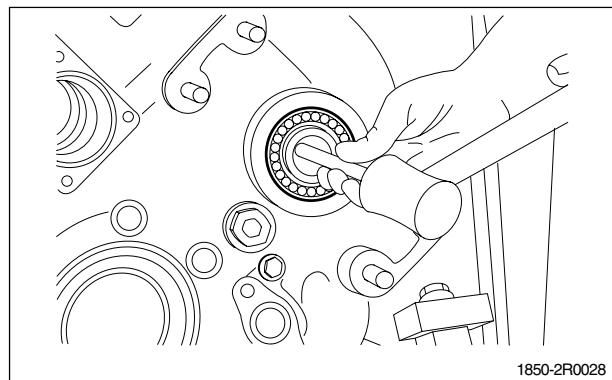

**Fig. 2-28**

Remove the covers of the forward and medium range clutch spools.

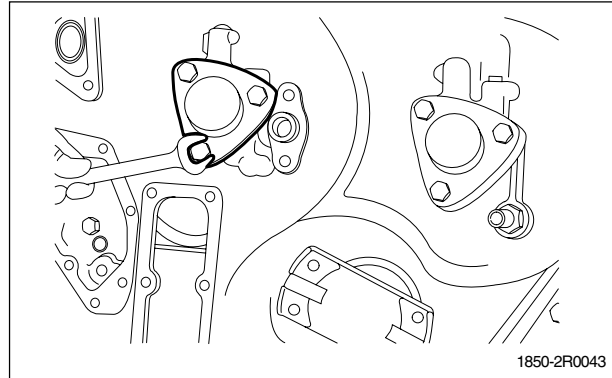

**Fig. 2-58**

Pull-out the clutch spools from the shafts.

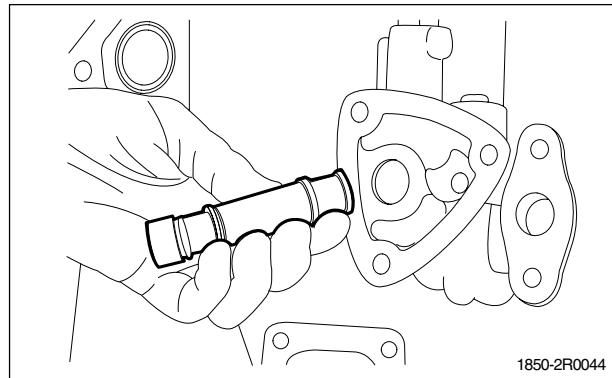

**Fig. 2-59**

Remove the input shaft drive flange.

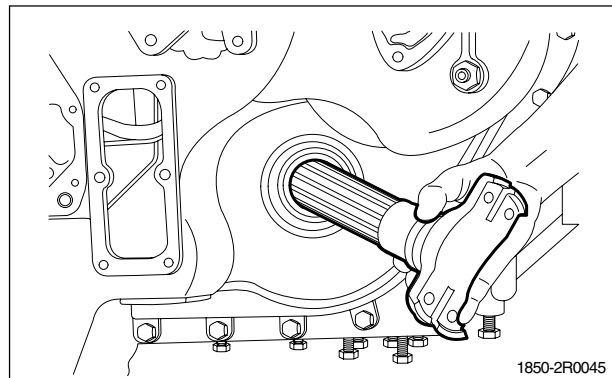

**Fig. 2-60**

Turn the transmission assembly and remove the transmission control valve assembly, loosening the screws (q.ty 5).

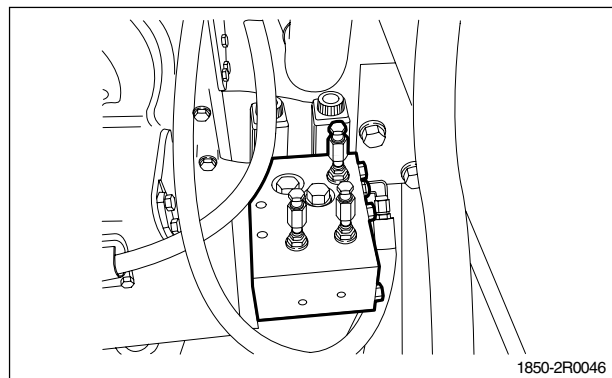

**Fig. 2-61**

Remove the bearing and the retaining wing of the relevant spacer.

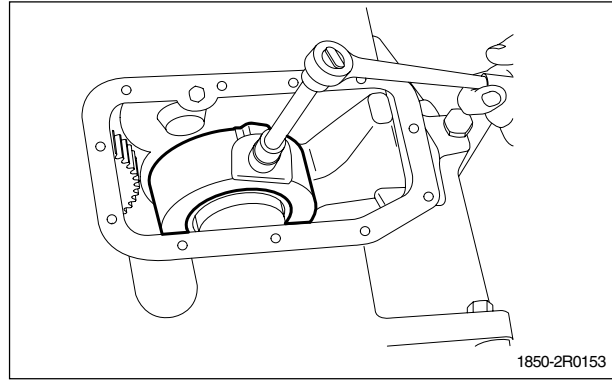

**Fig. 2-98**

Remove the bearing spacer using a securing screw.

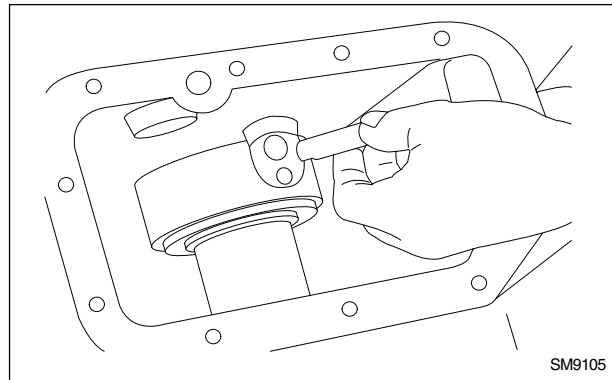

**Fig. 2-99**

Remove the output shaft nose bearing circlip.

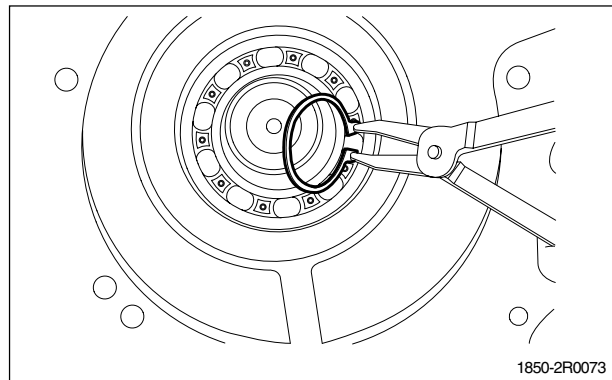

**Fig. 2-100**

Remove the output shaft gear circlip.

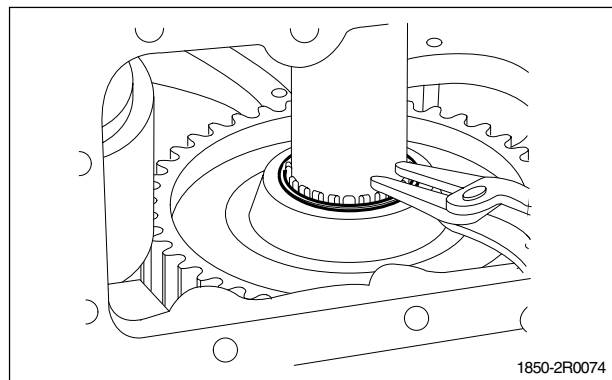

**Fig. 2-101**

### 2.5.6 OVERHAUL OF THE REV SPEED CLUTCH

Remove the locking tools from the reverse clutch assembly.

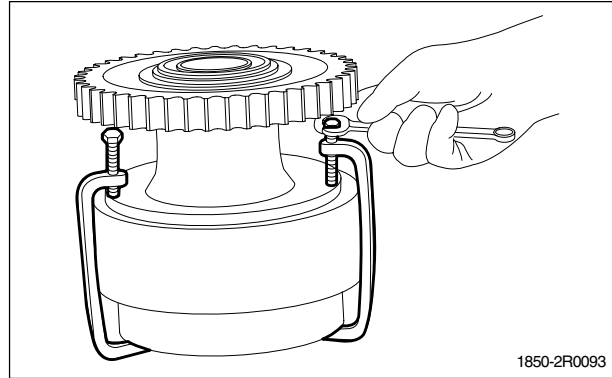

Fig. 2-138

Separate the reverse clutch drum from the clutch assembly.

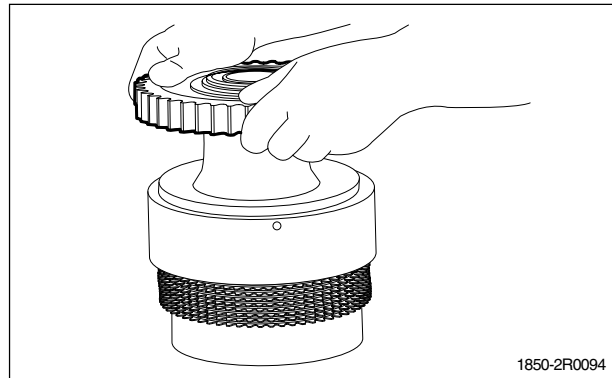

Fig. 2-139

Remove the clutch pack-hub from the piston-housing assembly.

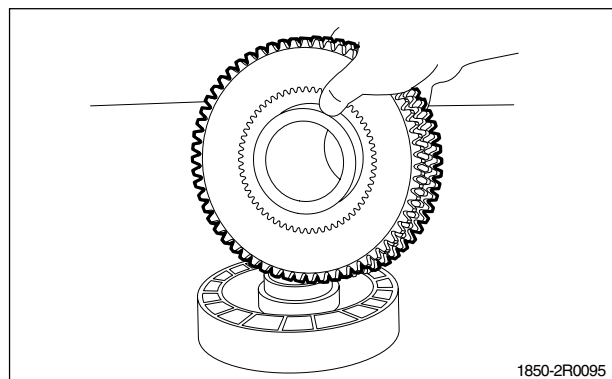

Fig. 2-140

Remove the clutch pack from the hub.

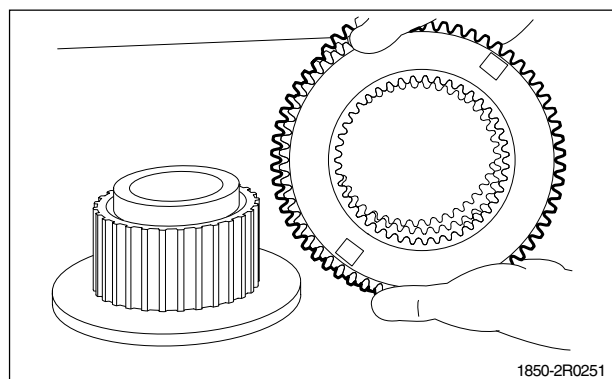

Fig. 2-141

## Transmission housing

	Thread	daNm (*)	ft lb
1. Nuts, rear cover studs	10 x 1.25	6.1 to 7.7	44.99 to 58.79
2. Screws and nuts, low range clutch cover and housing	10 x 1.25	6.1 to 7.7	44.99 to 58.79
3. Screws, reverse clutch front bearing cover	10 x 1.25	6.2 to 6.8	45.73 to 50.15
4. Screws, reverse clutch spool	10 x 1.25	5.7 to 6.3	42.04 to 46.46
5. Screws, reverse clutch seal	10 x 1.25	4.8 to 6.0	35.4 to 44.25
6. Screws, side cover	10 x 1.25	4.8 to 6.0	35.4 to 44.25
7. Screws, clutch spool cover	10 x 1.25	3.4 to 5.7	25.08 to 42.04
8. Screws, rear bearing holder	10 x 1.25	5.4 to 6.8	39.83 to 50.15
9. Self-locking screws, high range driven gear and medium/high ranges drive gear	12 x 1.25	11 to 12	81.13 to 88.5
10. Nuts and screws, securing the transmission housing to bevel gear pinion housing	16 x 1.5	24	177
11. Nuts, transmission shafts locking	40 x 1.5	92 to 95.5 (**)	679 to 704.31

(\*) Lubricate with engine oil - (\*\*) Apply Loctite 242

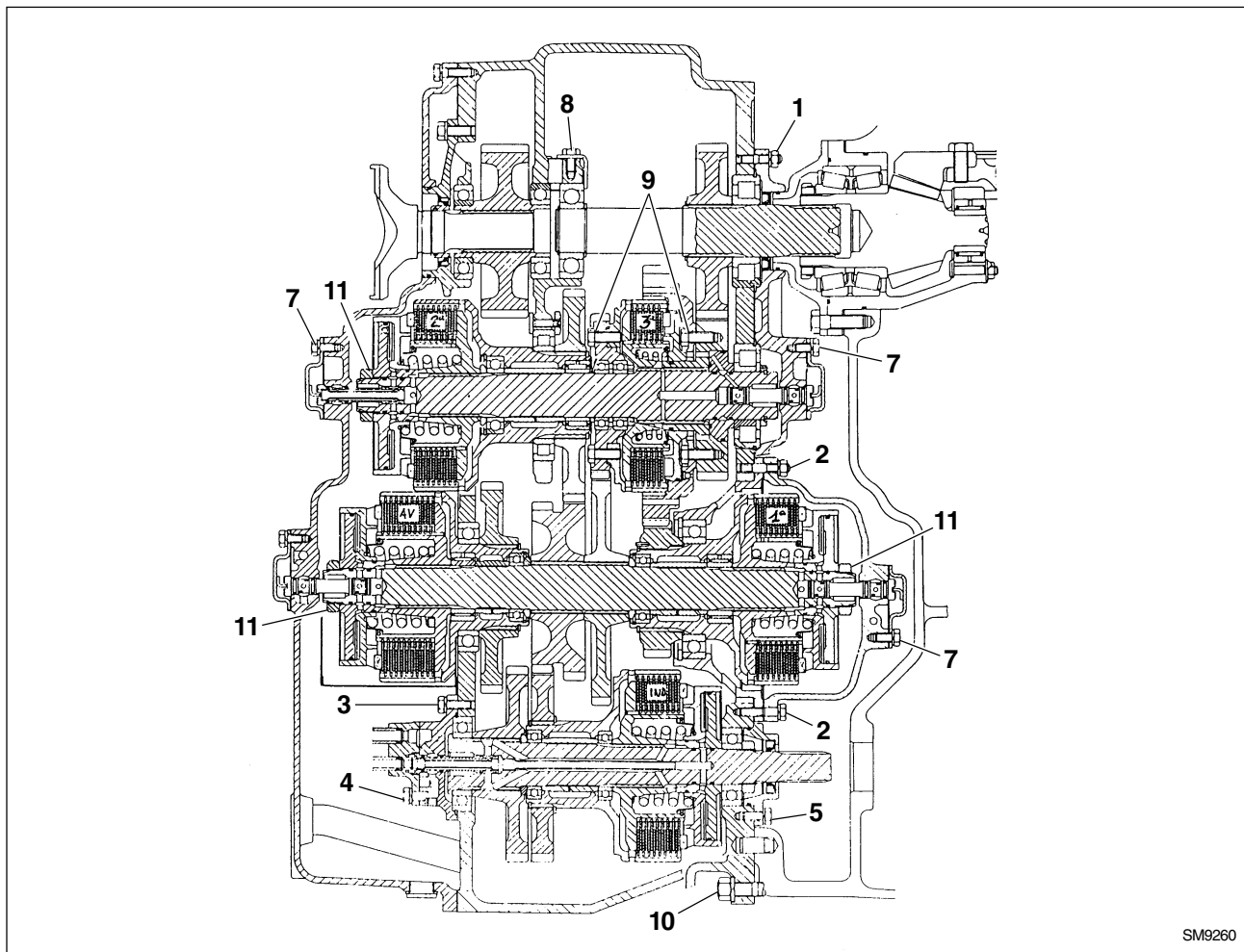

Fig. 2-169 Section view of transmission housing

380001470		Reverse clutch pack retaining tool
-----------	--	------------------------------------

Turn reduction gear upside-down and remove the retaining screws (186) (see fig. 3-2) of the sprocket wheel shaft and pull out the assembly from the reduction gear housing, as illustrated in the mentioned figure using two eyebolts (M24x2).

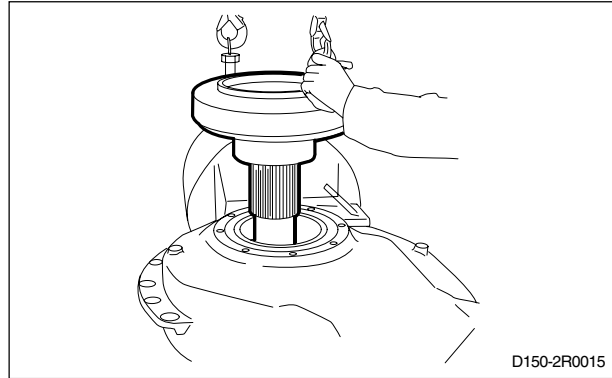

Fig. 3-16

Turn reduction gear upside-down, remove locking tool A (fig. 3-15) and pull out the driven gear as illustrated in the figure using a common grab.

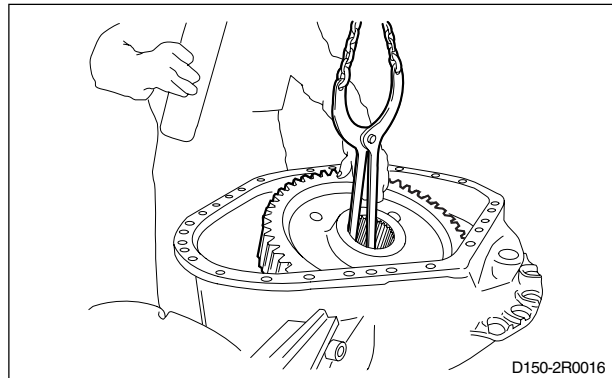

Fig. 3-17

### 3.2.2 PULLING THE HOUSING COVER

Remove the outer straight roller bearings from the cover with the appropriate puller, only in the event they must be replaced.

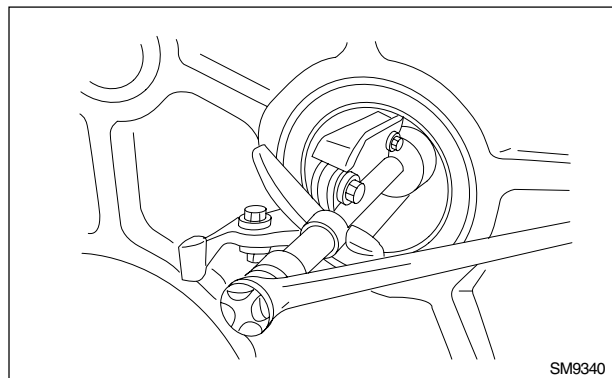

Fig. 3-18

If necessary, adjust the seat to insert the key.  
Repeat the same operations on the sprocket shaft bearing housing, as well.

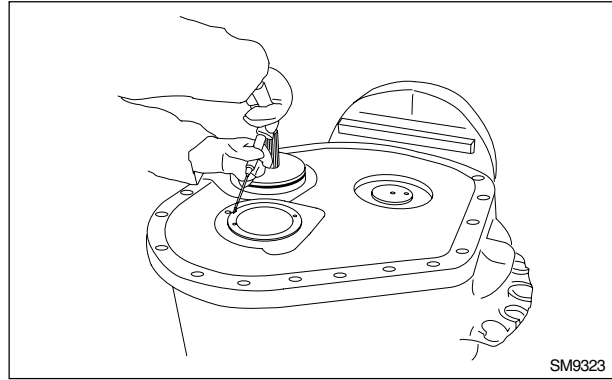

Fig. 3-51

Apply **LOCTITE 518** in the stop races seats and insert them.

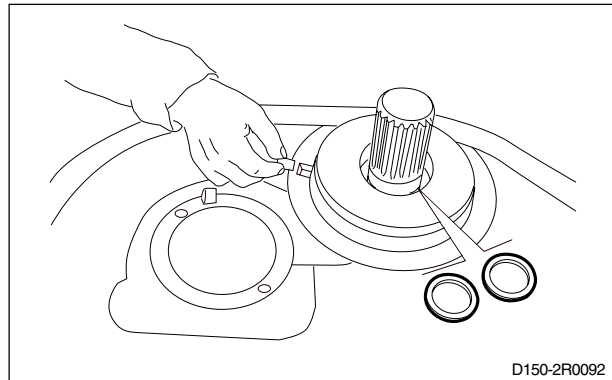

Fig. 3-52

Use an installer (**B**) (P/N **380001473** and **380001447**) to fit the two driving gear oil seals, with surfaces oriented as illustrated in detail **A** for seal installation

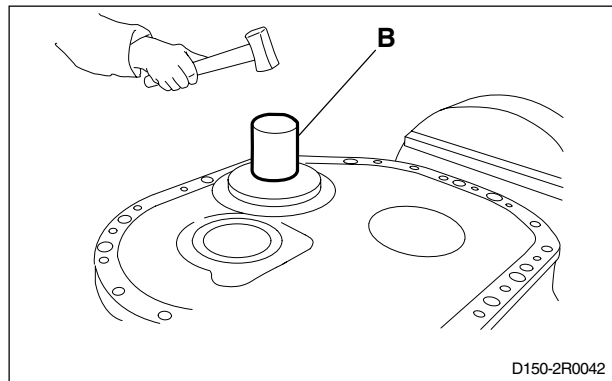

Fig. 3-53

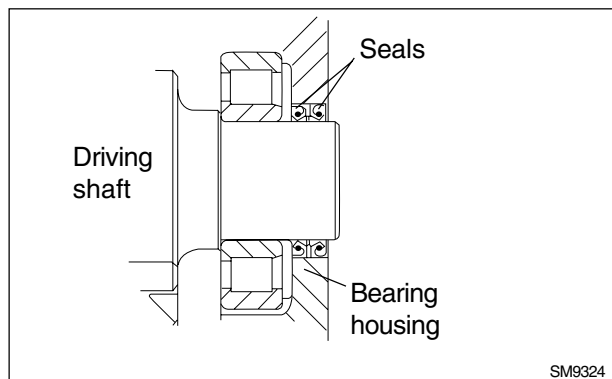

Fig. 3-54

Detail A - Seal installation.





CLICK HERE TO **DOWNLOAD** THE COMPLETE MANUAL

- Thank you very much for reading the preview of the manual.
- You can download the complete manual from: [www.heydownloads.com](http://www.heydownloads.com) by clicking the link below



- Please note: If there is no response to CLICKING the link, please download this PDF first and then click on it.

CLICK HERE TO **DOWNLOAD** THE COMPLETE MANUAL

### Procedure for the lever calibration without BB3 instrument

To complete the connections, please follow the diagram as in the figure, proceeding as follows:

Remove plate (1\*) from the cab left beam and pull-out cap (2) installed on electric connector (3) then connect connector (4) and connector (3).

1. Arrange the two switches on the setting box as follows:

Switch **A** in position "**CAL**"  
Switch **B** in position "**DSD**"

2. Lower the safety levers

3. Place starter key on "**ON**" (second step of the key); "**0**" appears on the display.

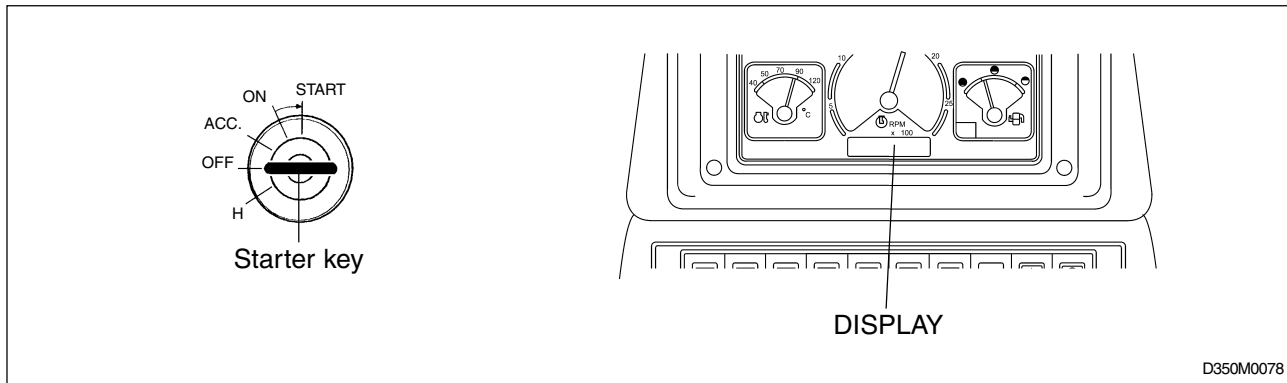

Fig. 4-25

4. Press neutral button "**N**" on the armrest; "**CAL0**" appears on the display.
5. Press neutral button "**N**" again; the display shows "**00**" and then "**0**" (calibration of levers at rest adjusted).
6. Press neutral button "**N**"; the display shows "**CAL1**".
7. Actuate both the levers indicated at the same time to stroke-end.
8. With levers moved to stroke-end, press neutral button "**N**"; the display shows "**FF**" and then "**0**".
9. Release the levers into rest conditions (calibration of levers at stroke-end adjusted).
10. Move the starter key into "**OFF**" and disconnect connector (4) from connector (3).
11. Install cap (2) on connector (3) and re-install plate (1) on the cab beam.
12. Calibration of steering levers completed.

Remove securing screws (17) of the two shaft gears and remove washers (18) and discs (19).

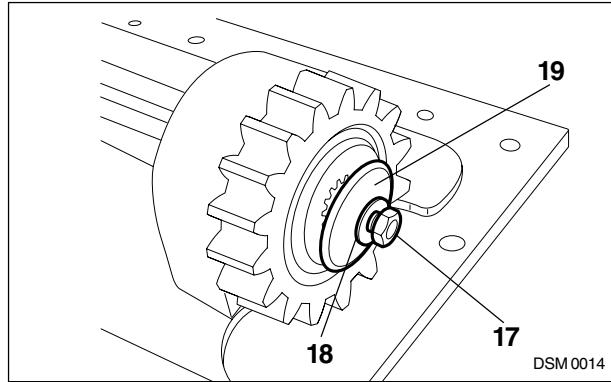

Fig. 4-46

Then, remove the two gears (20).



**WARNING**

Handle all heavy parts with the utmost attention. Never place hands and fingers between one part and another. Wear approved personal protection devices such as glasses, gloves and safety shoes.

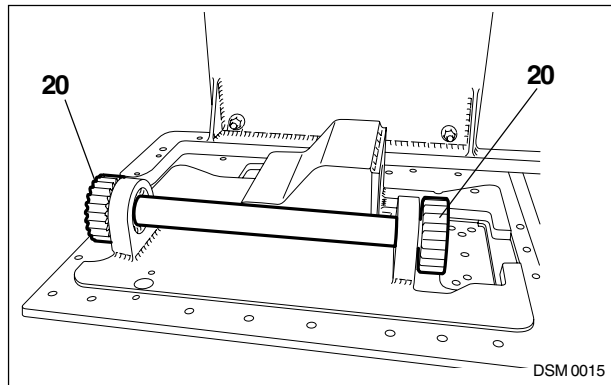

Fig. 4-47

Remove spacer (21) on the mobile race bearing side, right side.

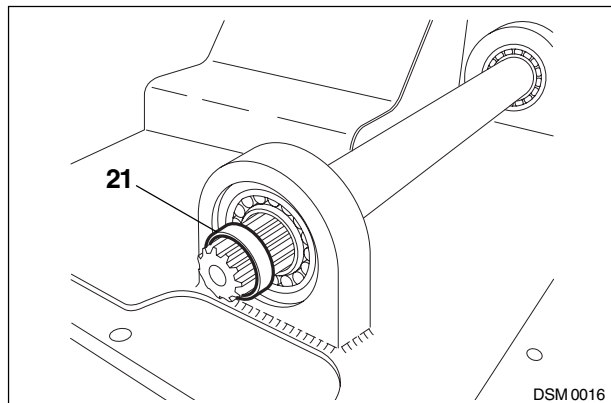

Fig. 4-48

Pull-out two spacers (22 and 23) on the fixed race side of the bearing, left side.

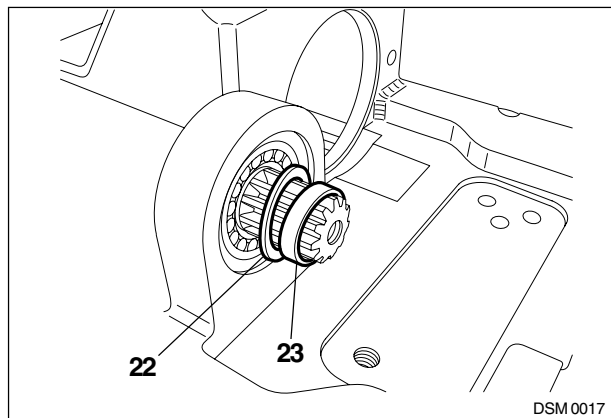

Fig. 4-49

Install the safety circlip to block the bearings in the seat.

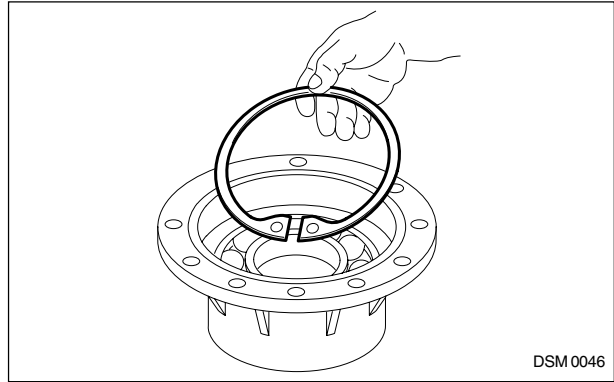

Fig. 4-82

Install housing assembly (2) on disc (1).

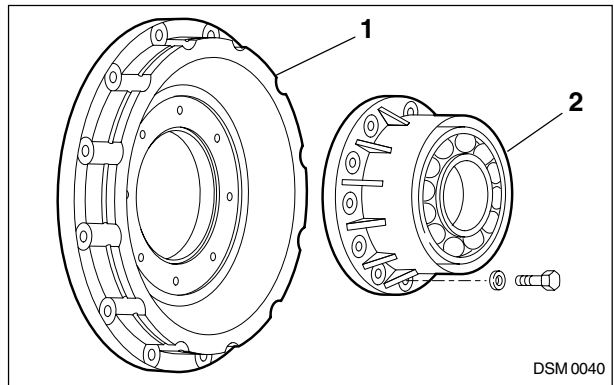

Fig. 4-83

Install the screws complete with washers using a centring punch and tighten with a torque wrench to 7.2 daNm (53.1 ft.lb.).

**Note** – Lubricate adequately all O-Rings and contact parts before the instal.

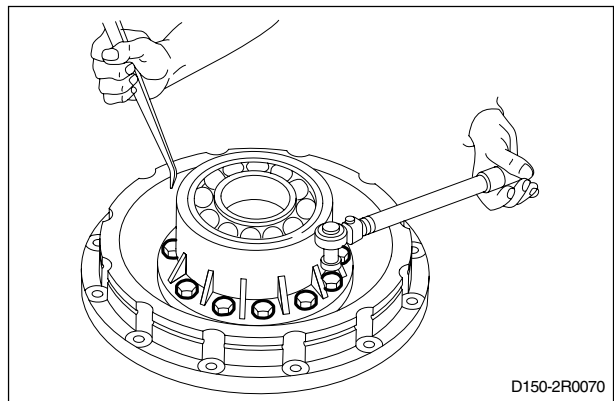

Fig. 4-84

Insert the first outer O-Ring in the seat on the support disc.

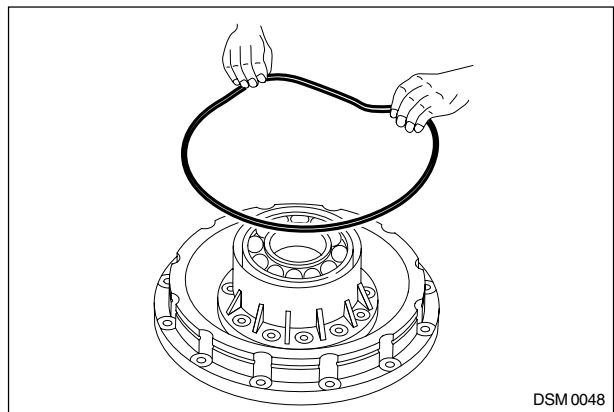

Fig. 4-85

Install a puller to remove the bearing housing from the bevel gear crown shaft until it gets out the taper splines, complete with the seat. Repeat the same procedure on the other side of the housing, and pull the shaft and crown assembly out.

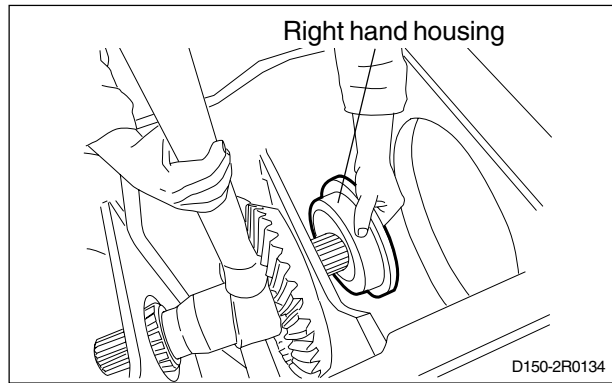

Fig. 4-116

**Disassembly of bevel pinion**

Secure the pinion in the appropriate bracket and place it in a vice.

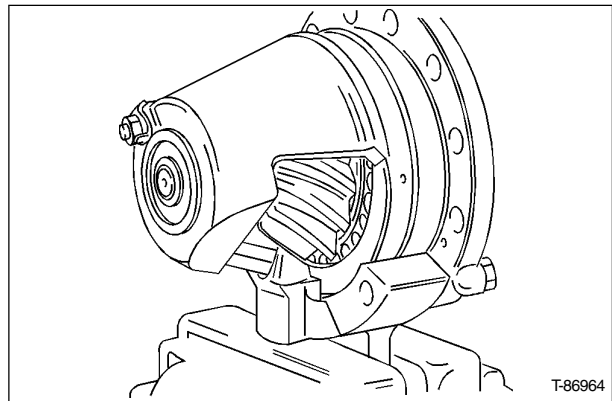

Fig. 4-117

Remove the cover using a screwdriver inserted in the appropriate notches on the cover itself.

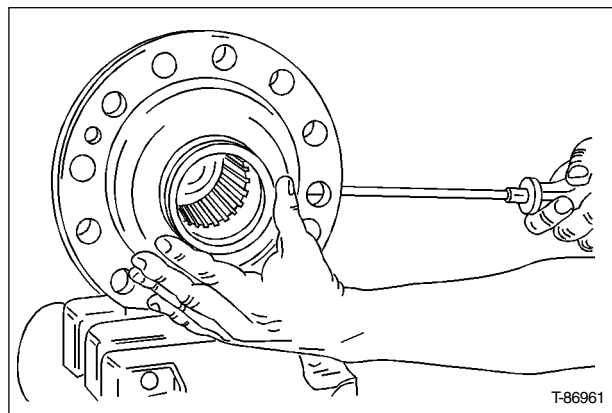
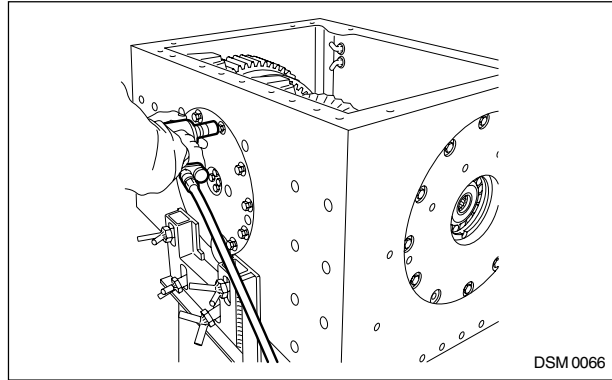

Fig. 4-118

**4.4.5 BRAKE GROUP AND PINION ON BRAKE SIDE**

**Removal of the brake group**

Remove the screws from the brake group.



**Fig. 4-154**

Install two guide studs (1) (M12x1.25x150) onto the transmission housing in correspondence of the holes for the brake unit.

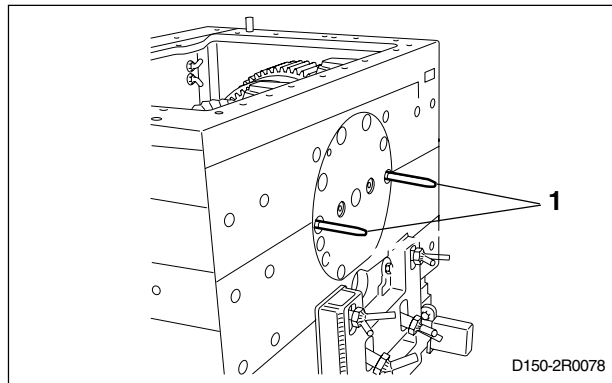
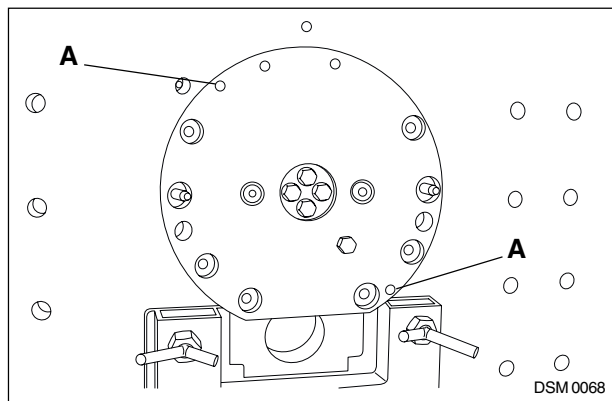

**Fig. 4-155**

Pull-out the brake group using two screws on threaded holes (A).

**! WARNING**

**Lift and handle all heavy parts with a lifting device of appropriate capacity. Make sure that heavy parts are held by appropriate slings and hooks.**



**Fig. 4-156**

Insert securing tool (2) (P/N 380001596) on the group and lift it completely with a hoist.

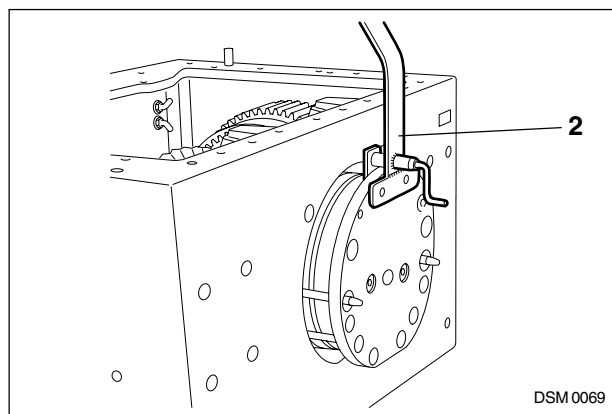

**Fig. 4-157**

First, install the left support assembly, without adjusting shims using 4 screws only tightened to a torque of 130Nm.

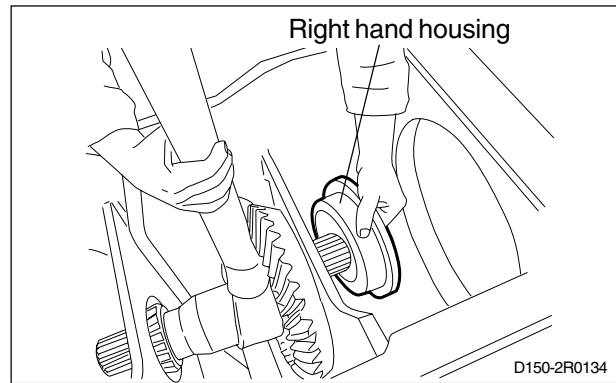

Fig. 4-190

Then, install the right support, without adjusting shims, with two retaining screws, tightening them with increments of 0.1 daNm up to a final value of 0.7 daNm. At the same time, turn a few times manually the gear crown, to set the taper rollers in the relevant races.

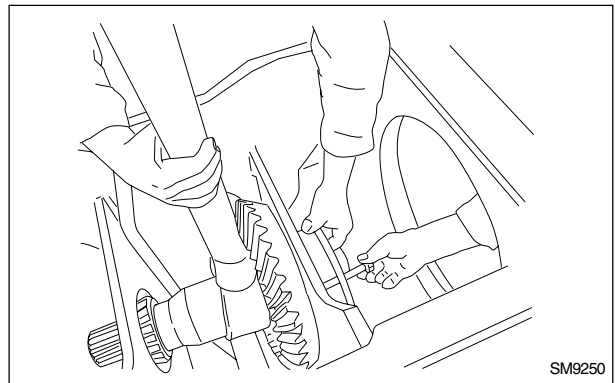

Fig. 4-191

### Re-installation of the pinion

Lubricate adequately all the mating faces of the pinion. Arrange the assembly for the re-assembly on the housing, slinging it with cables to a hoist.

To facilitate the centring of the pinion, use two guide screws (M12x1.25x150) and adjust the position and the backlash, as described in the previous paragraph for the adjustment of the bevel gear.

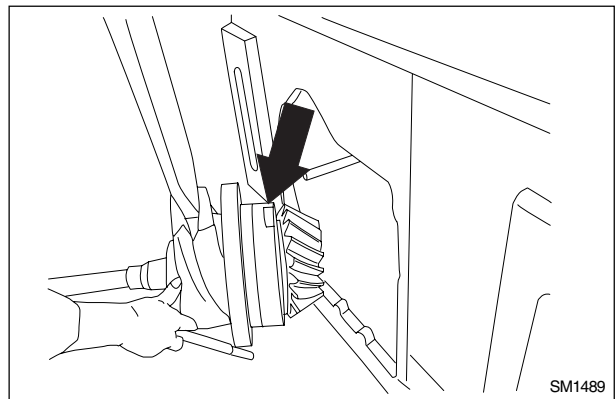

Fig. 4-192

Insert adjusting shims (1) then install the pinion into the housing and set its position and the tooth backlash as described in the preceding paragraph for the setting of the bevel gear crown.

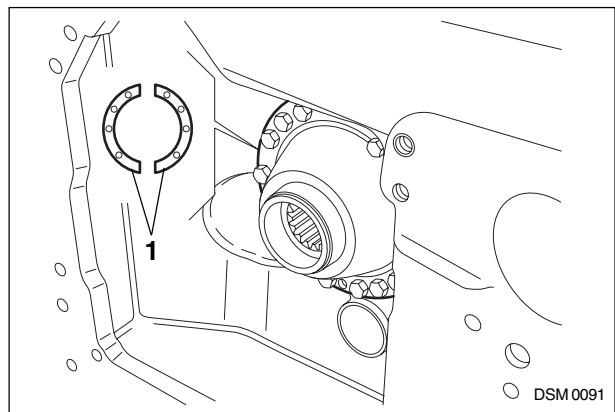

Fig. 4-193

Install spacer (13) on the shaft.

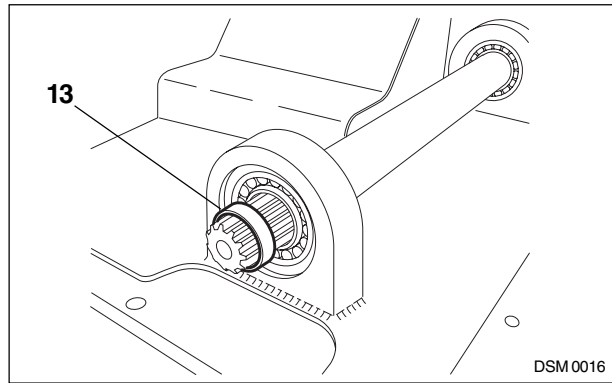

Fig. 4-224

Install the two spacers (14) and (15) on the left side of the shaft.

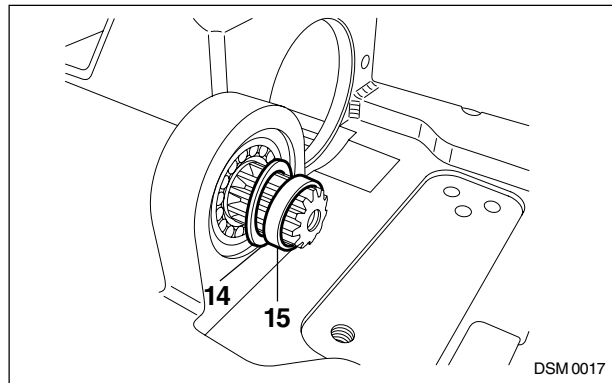

Fig. 4-225

Install the two gears (16) on the shaft.

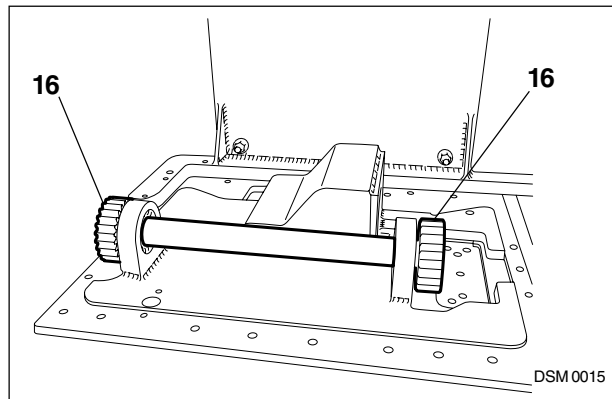

Fig. 4-226

Install disc (17) and securing screws (18) on the shaft. Repeat the operation on the opposite gear.

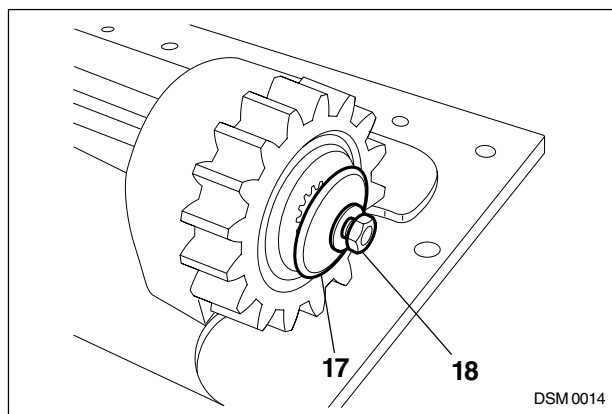
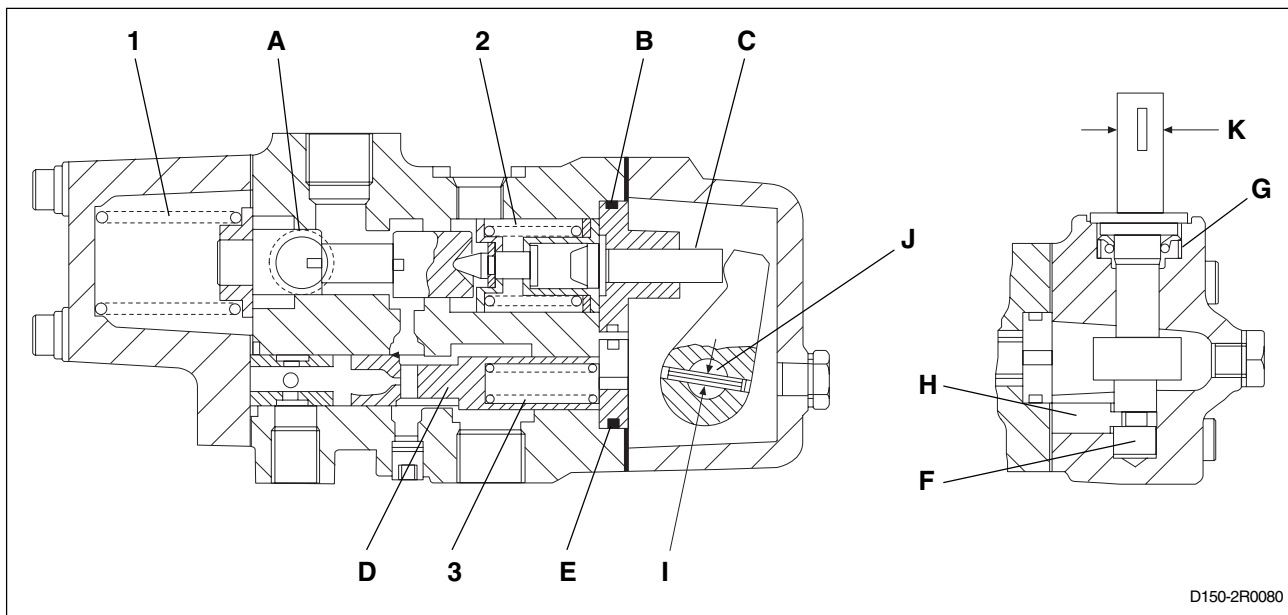

Fig. 4-227

<b>J.</b>	Diameter control seated in cam	13.016 to 13.059 mm (0.512 to 0.514 in)
	Outer diameter control pin in cam	12.973 to 13.000 mm (0.511 to 0.512 in)
	Play	0.016 to 0.086 mm (0.0006 to 0.0034 in)
<b>K.</b>	Diameter control seated in control lever	11.995 to 12.006 mm (0.472 to 0.473 in)
	Outer diameter control in lever	12.982 to 12.000 mm (0.511 to 0.472 in)
	Interference	0.005 int. to 0.024 play mm (0.0001 int. to 0.0003 play in)
<b>1.</b>	Piston return spring	
	Number of spring coils	9.5
	Free length	76.5 mm (3.012 in)
	Force required to press it 45 mm	54.7 to 60.3 daN (12.3 to 13.5 lbf)
<b>2.</b>	Piston actuating spring	
	Number of spring coils	5.5
	Free length	44 mm (1.732 in)
	Force required to press it 45 mm	28.4 to 31.4 daN (6.4 to 7 lbf)
<b>3.</b>	Plunger return spring	
	Number of spring coils	16.5
	Free length	49 mm (1.929 in)
	Force required to press it 45 mm	8.1 to 8.9 daN (1.8 to 2 lbf)



D150-2R0080

Fig. 4-244

Also, it is important, when the undercarriage is overhauled, to check the operation of the track tensioner device. An inefficient track tensioner can cause a premature wear of pins and bushes, the torsion of idler shafts, and, as a limit, troubles on the sprocket shafts and the final drives.

The more components are worn the faster wear occurs. When components are new, hardened surfaces are thick and resistant; with the wear progression of components between them and contact with the ground, their harder outer surfaces are replaced by softer layers of material, thus the wear becomes faster.

What said above can be summarised in a few preventive rules and operations:

- do not operate the machine at high speed, unless

this is strictly necessary. This is particularly true when operating in reverse;

- reduce the load when it is felt that the track chain starts slipping;
- avoid parking the machine in mud, water or conditions facilitating corrosions;
- inspect daily the components, check the tightening of bolts and nuts, eventual leakages from seals or signs of abnormal wear;
- clean mud and debris accumulated during the work shift from the undercarriage.

### 5.1.2 MAIN COMPONENTS

The main components making the undercarriage are:

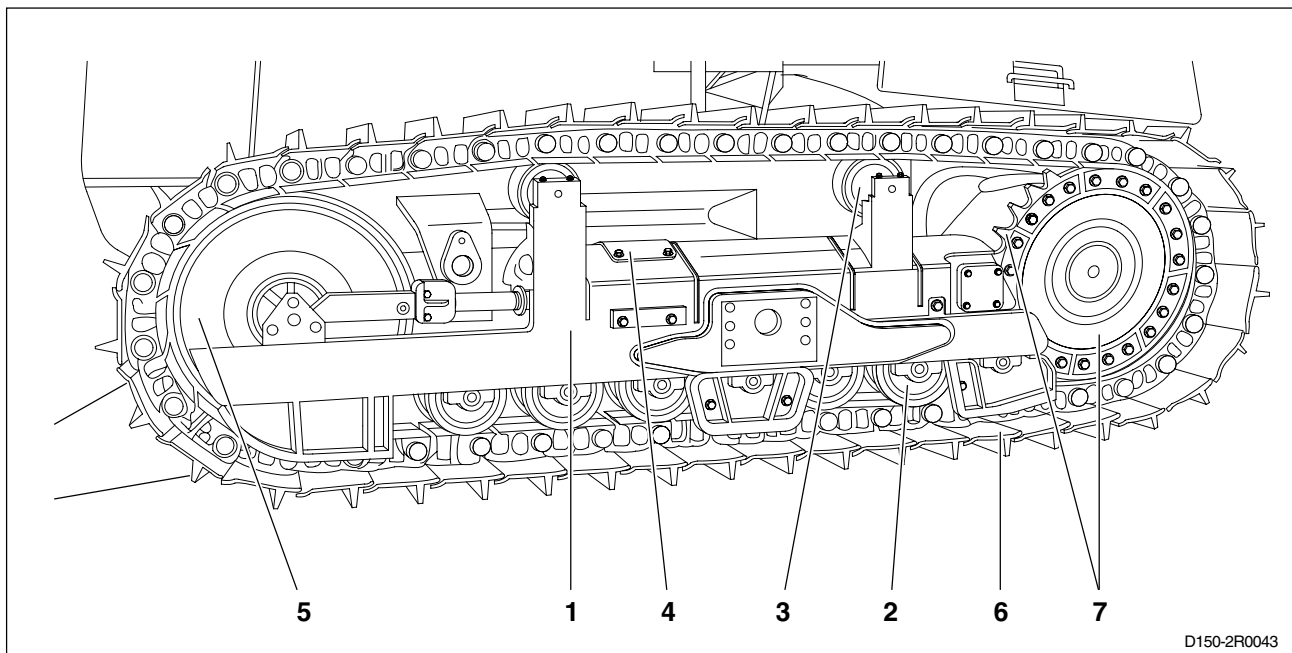

**Fig. 5-1 Undercarriage main components**

1. Track frames - 2. Track frame bottom rollers - 3. Track chain support rollers - 4. Track tensioner device and pressure relief valve - 5. Idler wheels - 6. Track chains - 7. Sprocket and toothed segments.

### Re-assembly of a lubricated track chain

Prior to reassembling the components of the track chain, follow the notices and procedures listed in item 5.4.1.

1. Press the pins using the portable hydraulic press.
2. Press the rubber plug into the pin hole using tool (A fig. 5-17). Take care in positioning the plug inside 8 to 10 mm (0.315 to 0.393 in) from the rim of the pin.
3. Check the tightness of the seals and the oil filling into the pins, using tool (B) fig. 5-18.

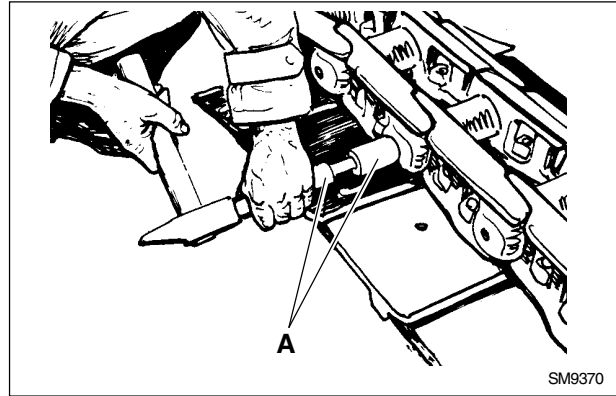

Fig. 5-17

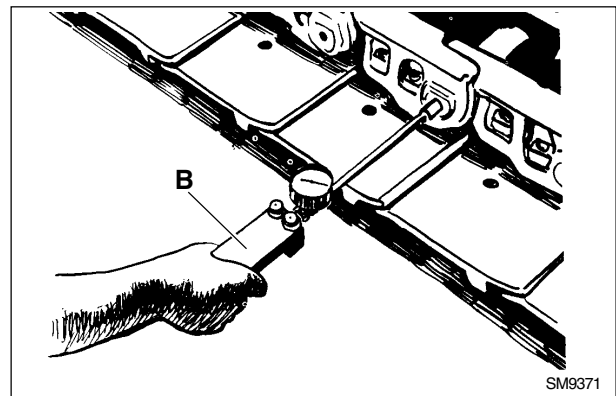

Fig. 5-18

### 5.4.3 IDLER (removal, installation)

#### Removal

1. Split the track chain (see item 5.4.1 **TRACK CHAIN - removal**).
2. Remove the idler guards.
3. Remove screws (1 fig.5-19) securing the idler supports.
4. Separate the idler from yoke (2) fig. 5-20.

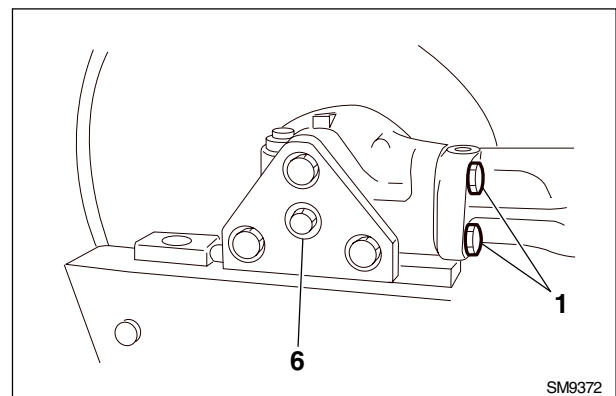

Fig. 5-19

#### **WARNING**

Handle all components with extreme care. Never place hands and fingers between one piece and another.

5. Remove the idler from the machine using tool (A) fig. 5-21.

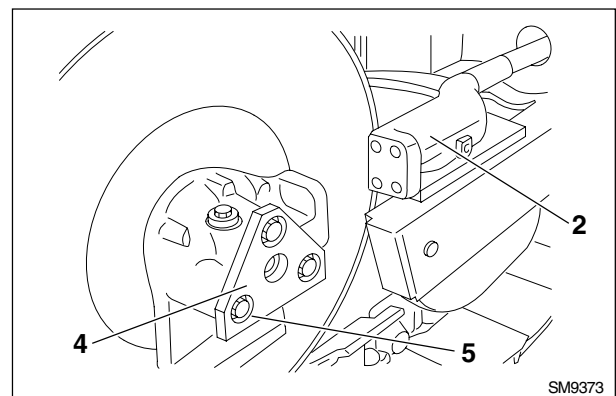
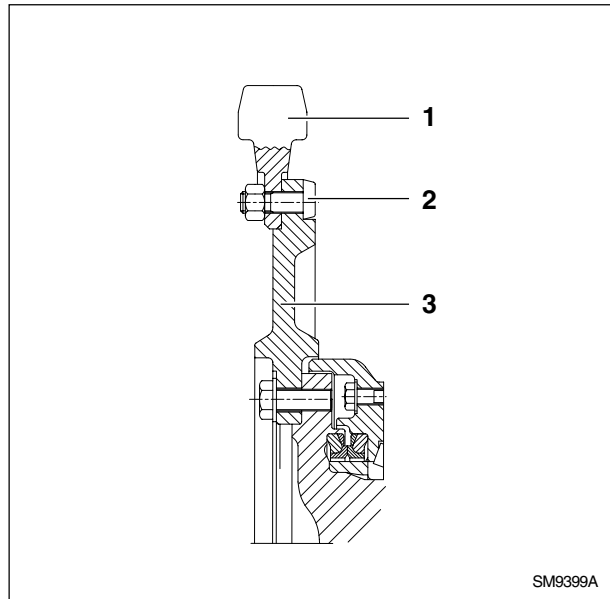

Fig. 5-20

**5.5.2 SPROCKETS**

Type .....bolted segments  
 Number of teeth per crown ..... 28  
 Sprocket pitch diameter .....790.94 mm (31.140 in)  
 Width of segment ..... 70 mm (2.756 in)  
 Wear limit .....(see pag 5-30)



**Fig. 5-44 Section view of sprocket**

1. Toothed sector - 2. Sector securing screw - 3. Hub.

**5.5.3 TRACK CHAINS**

Link type ..... with master pins  
 Number of shoes per track chain 42 plus master shoe  
 Total shoes per track chain .....43  
 Totale suole per cingolo (vers. LGP) ..... 48  
 Number of split master links per track chain .....2

Width of shoes:

- standard 500 mm (19.685 in)
- optional ..... 550 mm (21.653 in)
- LGP ..... 800 mm (31.496 in)

**Note** - Prior to installation, degrease screws (C) and the treaded seats on master links (1).

Apply **LOCTITE 243** on the screw tread and tighten to the prescribed torque. Lubricate the other screws (C1) with engine oil and tighten to the prescribed torque.

**Tightening torques**

Master link C securing screws (21 to 30 daNm) (154.875 to 221.25 ft lb) plus a further 1/2 turn tightening.

Shoe securing screws C1 (46 to 54 daNm) (339.25 to 398.25 ft lb) plus a further 1/3 turn tightening.

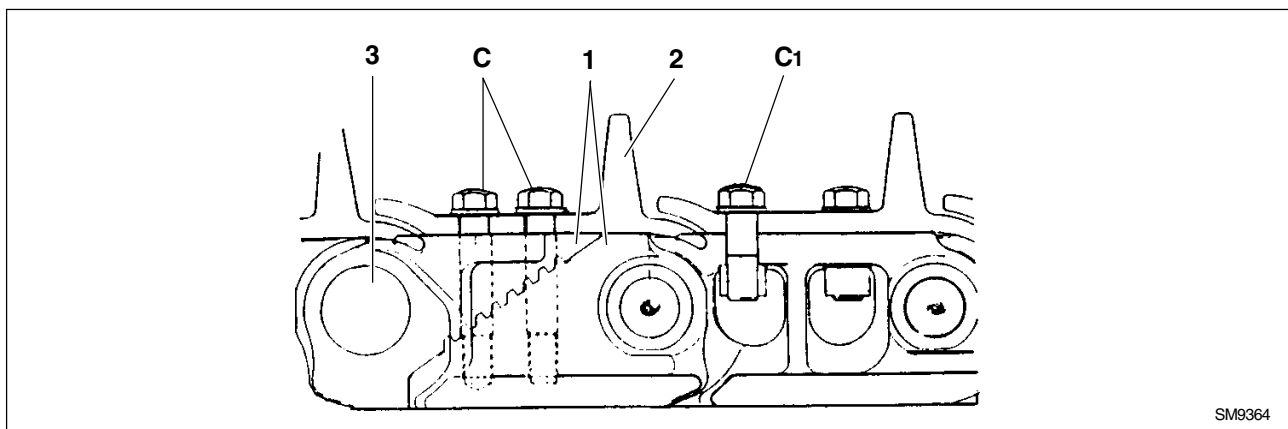

**Fig. 5-45 Master links**

1. Split master link - 2. Master shoe - 3. Link pivot pin - C. Master link hinging securing screws - C1. Shoe and split link securing screws.



## 6.3 REPAIR PROCEDURES

### 6.3.1 HYDRAULIC OIL TANK (removal/installation)

#### Removal

Turn the main switch "OFF" to disconnect the electrical system and place a sign "DO NOT OPERATE" on the switch, as indicated.



#### WARNING

To minimize the danger of fires and explosions it is recommended, prior to performing any welding on the fuel tank, to drain completely the fuel, disconnect the pipes and protect their ends and clean the tank inside. All traces of fuel must be eliminated prior to starting welding. Also flood the tank with carbon dioxide (CO<sub>2</sub>) before and during the welding.

When welding, all caps and covers must be removed and all other openings must be kept free to facilitate the ventilation.

Then, proceed as follows:

- tilt the cab;
- drain the hydraulic oil from the tank using a container of a capacity of at least 70 litres (18.5 gal.) loosening the appropriate plug (T) and magnetic rod (Z) located under the tank;
- disconnect the oil delivery and return pipes to the equipment control valve;

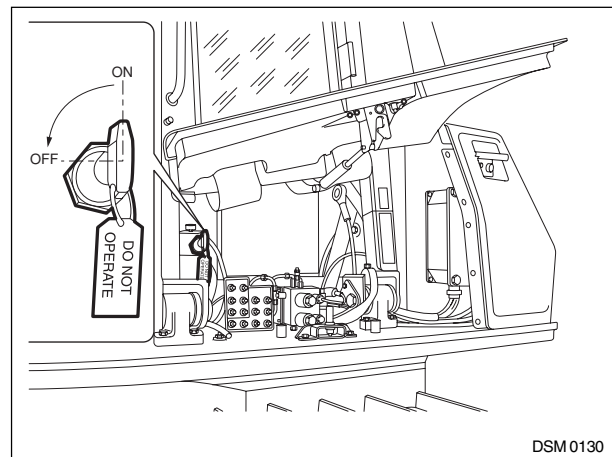

Fig. 6-4 Electrical system main switch

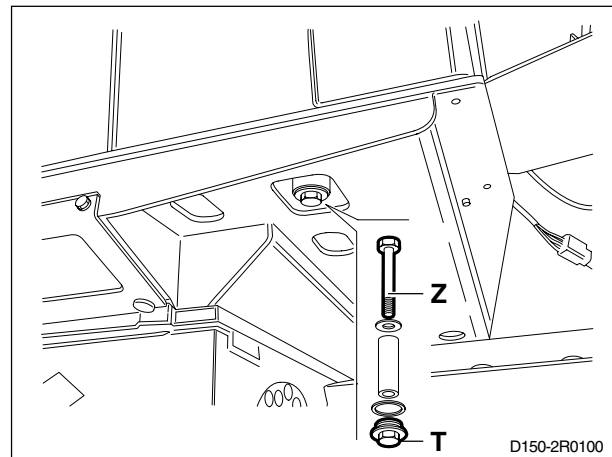
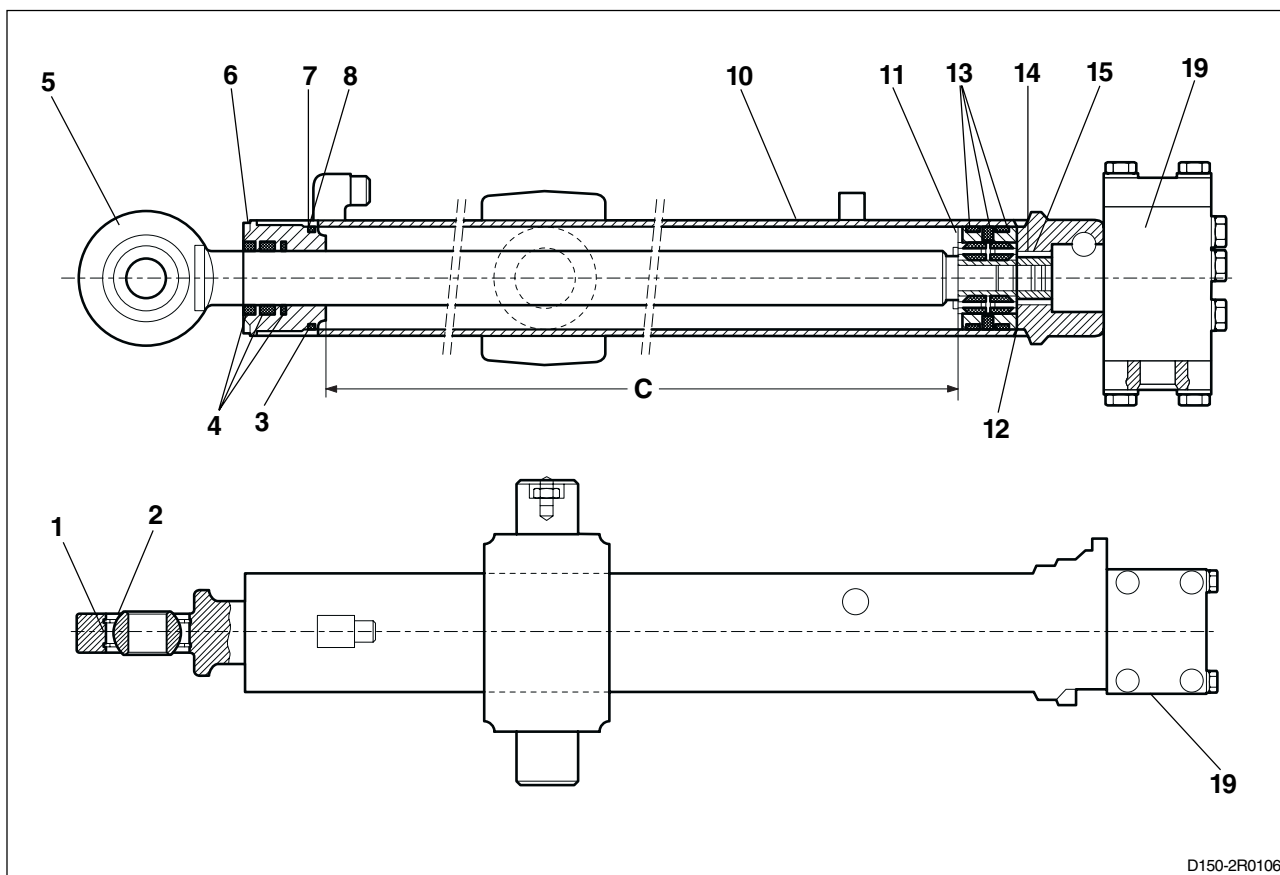

Fig. 6-5 Hydraulic oil tank

6.4.6 BLADE LIFTING CONTROL CYLINDER (Bulldozer version)



D150-2R0106

Fig. 6-17 Section view of blade lifting cylinder

- A. Rod nominal diameter ..... 45 mm (1.77 in)
- B. Piston nominal diameter ..... 80 mm (3.15 in)
- C. Cylinder rod strike ..... 1185 mm (46.65 in)
- Front sleeve (6) tightening torque ..... (80 to 88 daNm,  
589.8 to 648.8 ft.lb.)
- Piston (14) securing nut tightening torque ..... (31.5 daNm,  
232.2 ft.lb.)
- Dowel (15) tightening torque ..... (1.75 to 2 daNm,  
12.9 to 14.7 ft.lb.)

1.	Circlip
2.	Ball joint
3.	O-Ring
4.	Seals
5.	Rod
6.	Front sleeve
7.	Ring
8.	Seal
10.	Cylinder sleeve
11.	Piston
13.	Seals
14.	Nut
15.	Dowel
19.	Unloading valve (quick drop)

6.4.16 RIPPER (LGP version)

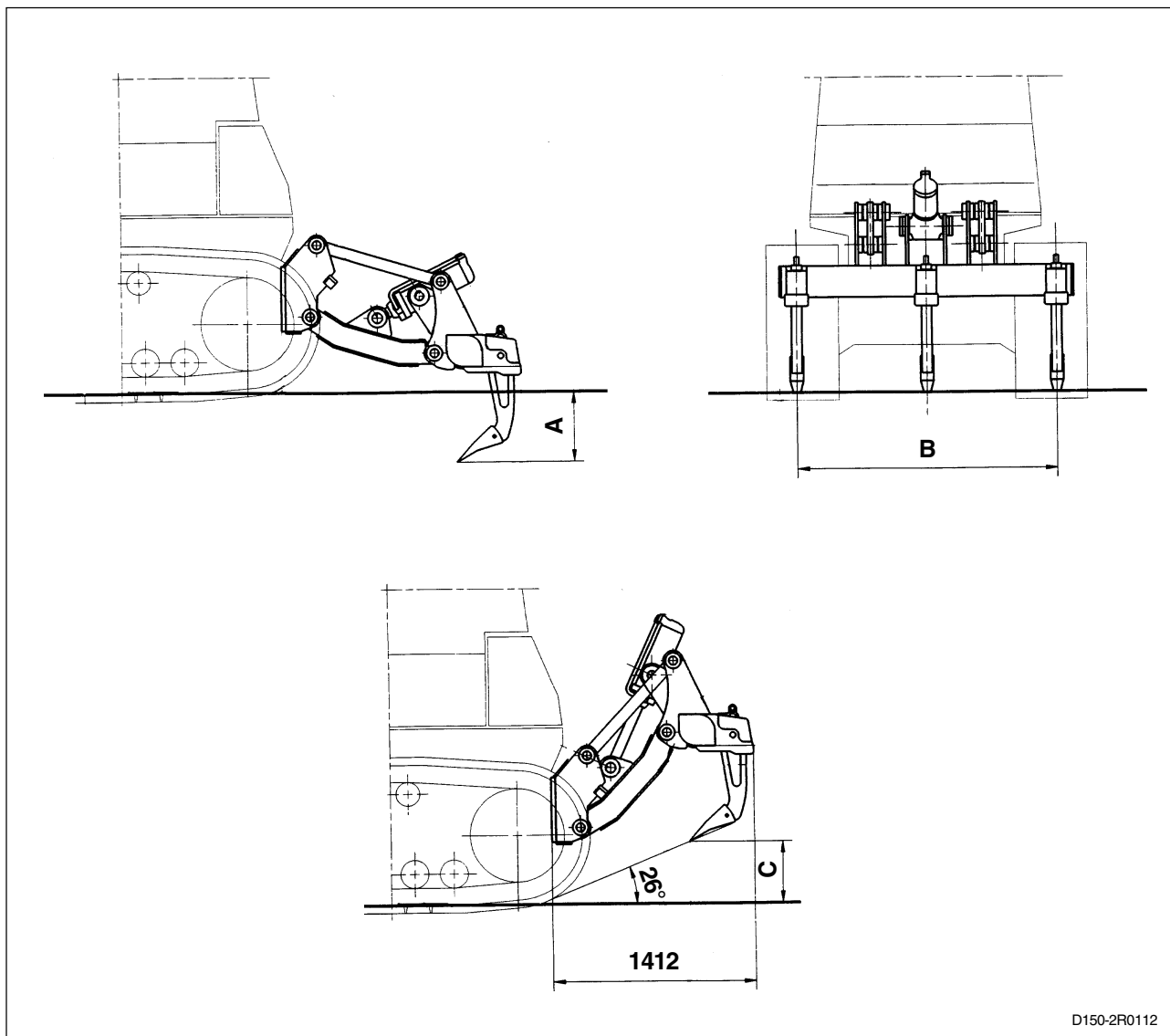

Fig. 6-27

- Model ..... RP10F  
 Type ..... Parallelogram, actuated by a double stroke cylinder, equipped with 3 semi-curved shanks with interchangeable tips
- A. Work depth (with shoes sunk) ..... 356 mm (14 in)
  - B. Maximum work depth ..... 1700 mm (67 in)
  - C. Maximum ground clearance of teeth (with shoes sunk) ..... 474 mm (18.7 in)
- Maximum break-up force (standing) ..... 10270 daN (369406 lbf)
  - Maximum penetration force (standing) ..... 7700 daN (276964 lbf)
  - Tightening torque of screws securing the support to transmission housing ..... 83 daNm (612 ft.lb.)

### 7.1.5 BACK-UP ALARM

#### WIRE

**163** To electronic controller

**000** To ground

LOCATION - Left rear side of machine, under fuel tank.

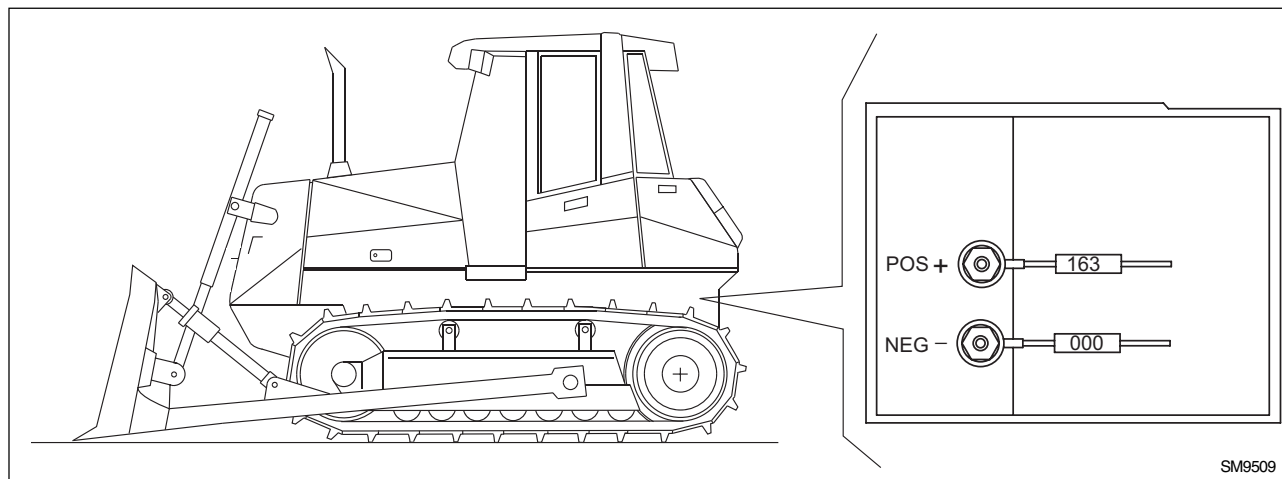

Fig. 7-11

### 7.1.6 STARTER MOTOR

Brand: DELCO - REMY

Type: 28 MT 6.8 kW

LOCATION - On engine.

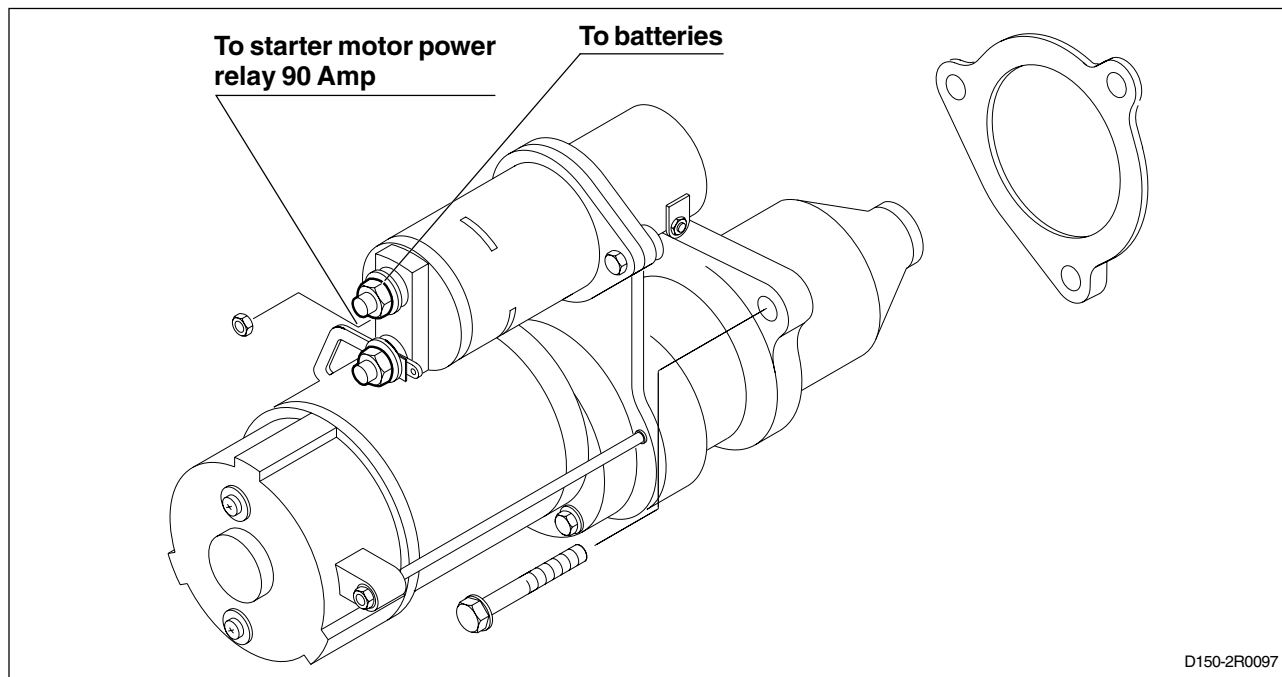

Fig. 7-12

## 7.5 DISPLAY

The display shows three functions:

- A) - **Digital hourmeter** indicating the total work hours automatically activated when the engine is operative.
- B) - **Speed selected**
- C) - **Diagnosis of the correct operation of the transmission**

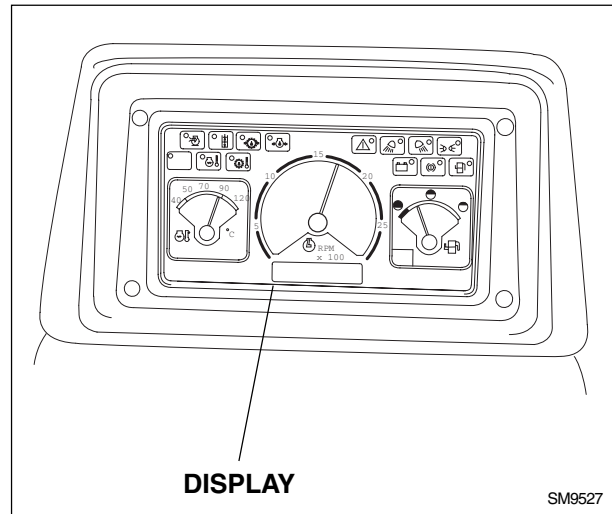

Fig. 7-33

### 7.5.1 DIAGNOSIS ON DISPLAY

The display has 5 text fields to signal following messages.

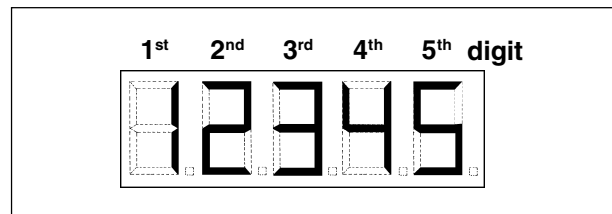

Fig. 7-34

A - **Work hourmeter signal**

or

B - **Gear engaged + failure code**

#### Work hourmeter signal

The engine hours are signalled by the lighting for about 1 second when the instrument board carries out the general test. To re-visualise the engine hours, it is necessary to switch off and switch on again with the starter key.

The engine hours stay ON as far as the engine is inoperative.

## SECTION 8

# AIR CONDITIONING UNIT

### TABLE OF CONTENTS

CHAPTER	SUBJECT	PAGE
8.1	AIR CONDITIONING UNIT .....	8-3
8.1.1	Operating instructions .....	8-3
8.1.2	Technical data .....	8-3
8.1.3	Cab climate conditioner and error codes .....	8-6
8.1.4	Service precautions .....	8-8
8.1.5	Tool connections .....	8-11
8.1.6	Discharging .....	8-12
8.1.7	Refrigerant charging .....	8-12
8.1.8	Leak inspection .....	8-13
8.1.9	Special tools .....	8-16
8.1.10	Troubleshooting .....	8-17
8.2	LIST OF OVERHAUL SPECIAL TOOLS .....	8-23

### 8.1.5 TOOL CONNECTIONS



#### WARNING

Do not connect hoses to the air conditioner system when the manifold gauge valves are open.



#### CAUTION

If there is any refrigerant in the air conditioner system, connect the hoses only after the service hoses and the manifold gauge have been evacuated.

1. Fully close both manifold gauge valves.
2. Connect the three hoses securely to the manifold gauge.
3. Connect the utility hose to the vacuum pump or refrigerant source.
4. Connect the couplers to the high and low pressure hoses. Turn the knob on the fitting to depress the core if so equipped.

Before disconnecting hoses, close both manifold gauge valves.

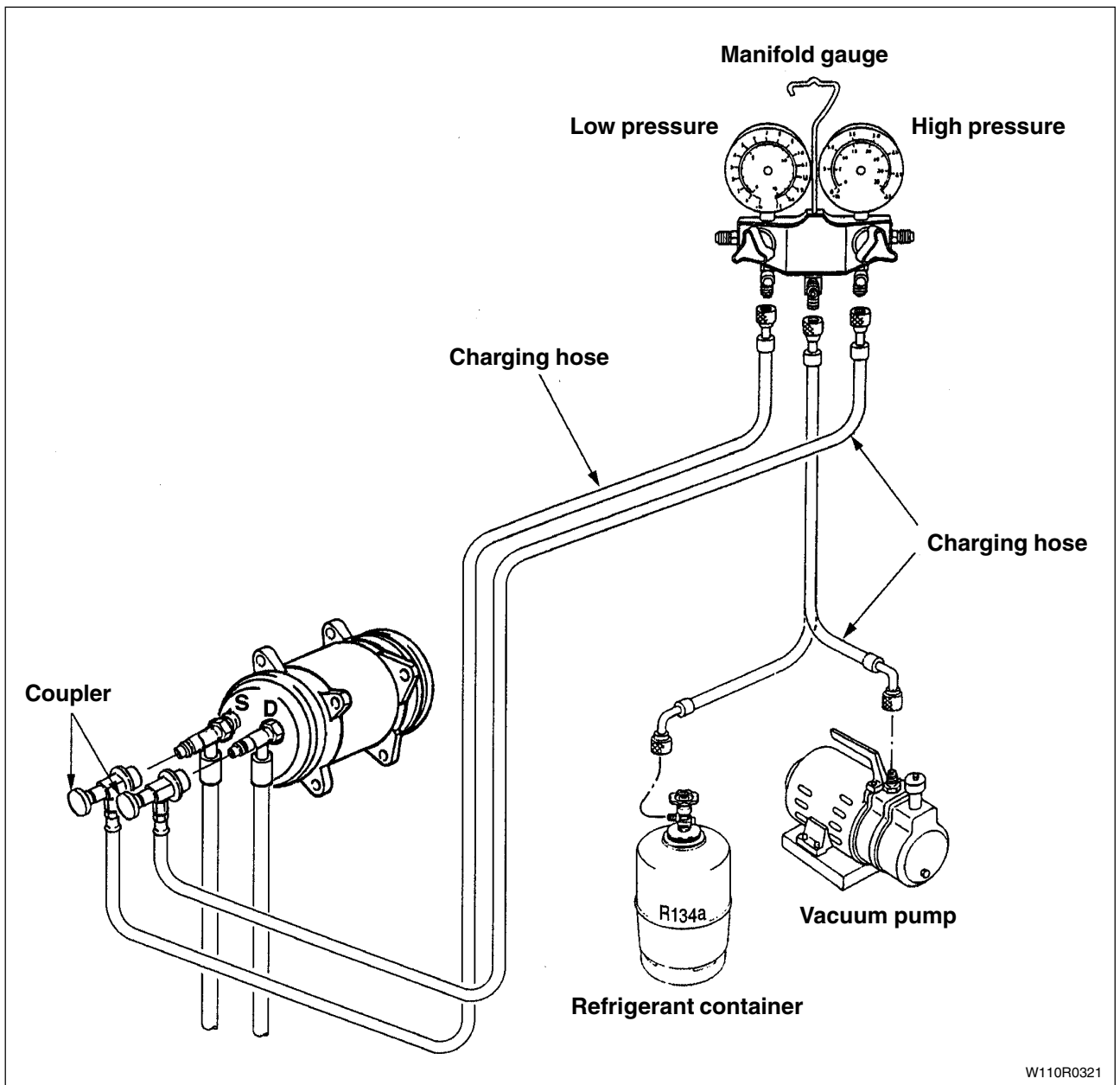

Fig. 8-7

CLICK HERE TO **DOWNLOAD** THE COMPLETE MANUAL

- Thank you very much for reading the preview of the manual.
- You can download the complete manual from: [www.heydownloads.com](http://www.heydownloads.com) by clicking the link below



- Please note: If there is no response to CLICKING the link, please download this PDF first and then click on it.

CLICK HERE TO **DOWNLOAD** THE COMPLETE MANUAL