

SERVICE MANUAL

CR6.80 / CR6.90 / CR7.90 /

CR8.90 / CR9.90

Tier 4B (final)

Combine

Part number 47865347

1st edition English

April 2015



CLICK HERE TO **DOWNLOAD** THE COMPLETE MANUAL

- Thank you very much for reading the preview of the manual.
- You can download the complete manual from: www.heydownloads.com by clicking the link below



- Please note: If there is no response to CLICKING the link, please download this PDF first and then click on it.

CLICK HERE TO **DOWNLOAD** THE COMPLETE MANUAL

Contents

Engine - 10

Air cleaners and lines - 202

SERVICE

Air cleaner	
Remove (*)	3
Install (*)	7
Cleaning (*)	11

(*) See content for specific models

Belt - Remove fan drive belts

CR6.80 TIER 4B	NA
CR8.90	NA
CR9.90	NA

⚠ WARNING

Avoid injury! Always do the following before lubricating, maintaining, or servicing the machine.

1. **Disengage all drives.**
2. **Engage parking brake.**
3. **Lower all attachments to the ground, or raise and engage all safety locks.**
4. **Shut off engine.**
5. **Remove key from key switch.**
6. **Switch off battery key, if installed.**
7. **Wait for all machine movement to stop.**

Failure to comply could result in death or serious injury.

W0047A

Prior operation:

Engine hood and panels - Remove (90.100)

1. Loosen belt tensioner spring to the fan drive pulley by tightening the nut **(1)** (clockwise) until there is slack in belts.
2. Remove the fan drive belts **(2)** from the pulleys.

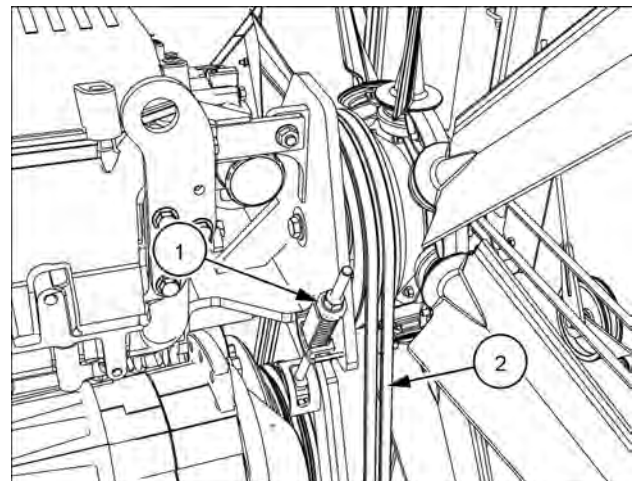

NHIL13CR00463AA 1

Next operation:

Belt - Install fan drive belts (10.414)

3. Position the mixer tube (1) to the Diesel Oxidation Catalyst (DOC) (2) and align to the horizontal mark (3) that was made during the removal process.

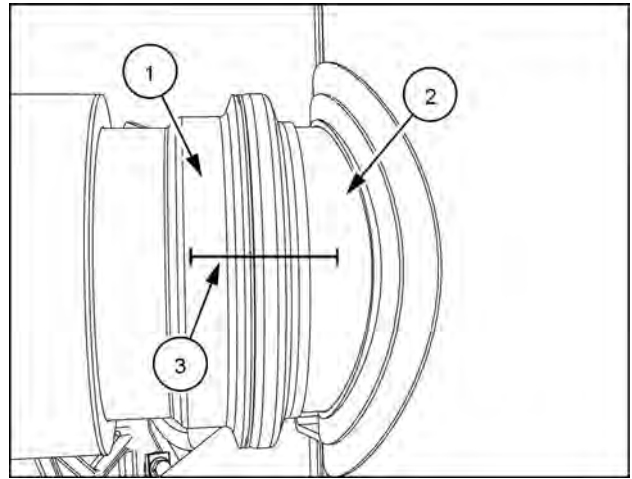

NHIL14AF00248AA 3

4. Install the tube clamp (1) to the DOC (2) and the mixer tube (3). Tighten the clamp to **12 N·m (106 lb in) ± 1 N·m (9 lb in)**

NOTE: It is recommended to install a new clamp and gasket.

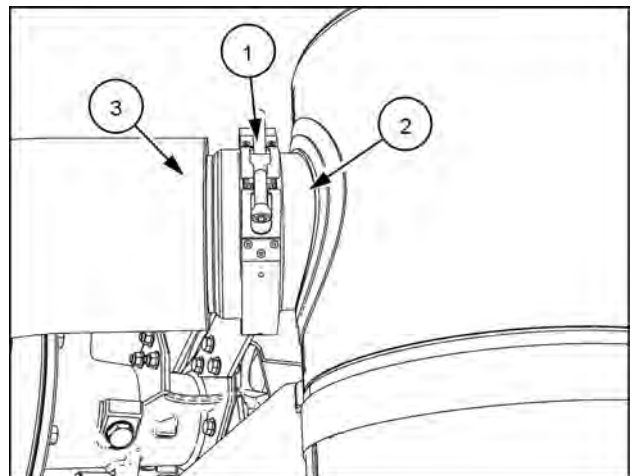

NHIL14AF00247AA 4

13. Remove the drive housing (1) from the gearbox.

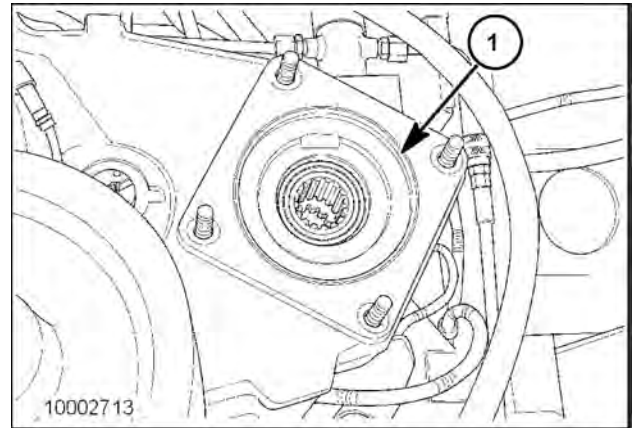

10002713 10

14. Lift the hydrostatic drive from the gearbox.
15. Turn the gearbox over and support it with the engine flange/input shaft pointing in the upward direction.

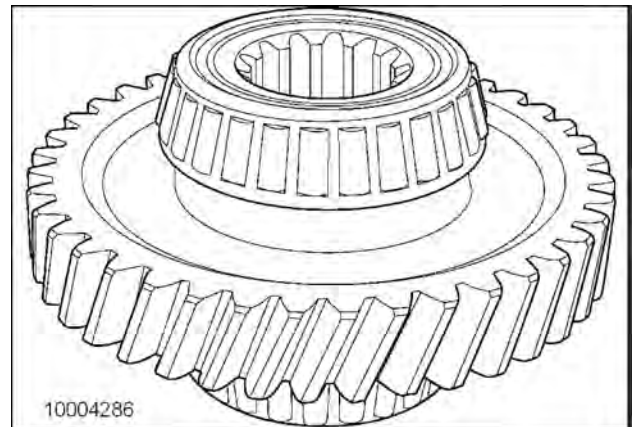

10004286 11

16. Remove cap screws (1) holding the engine flange onto the gearbox.
17. Separate the engine flange (2) from the gearbox.

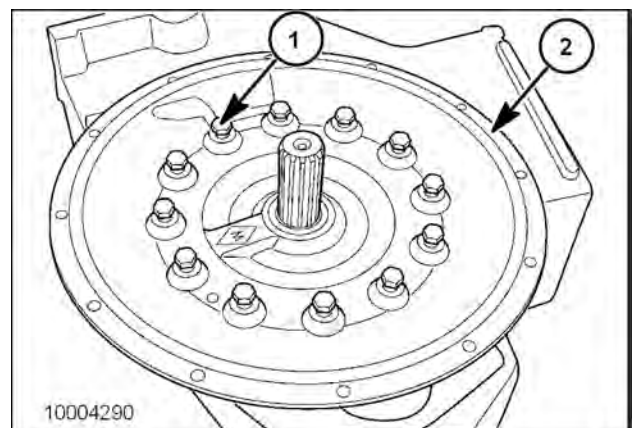

10004290 12

NOTE: When removing the engine flange, protect the shaft seal against damage from the multi-spline profile of the spur gear shaft.

Driven shaft - Disassemble

CR6.80 TIER 4B	NA
CR6.90	NA
CR7.90	NA
CR8.90	NA
CR9.90	NA

Prior operation:

Driven shaft - Remove (21.145).

1. Unlock lock washer (2).
2. Remove nut (1) using **380001074**, lock washer (2) and washer (3) securing the bearing cone (4).

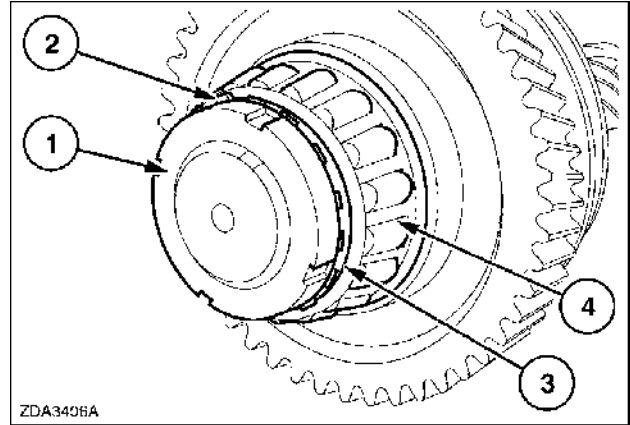

ZDA3406A 1

3. Remove gear (2) bearing (1) and the washer between the two parts with a puller.

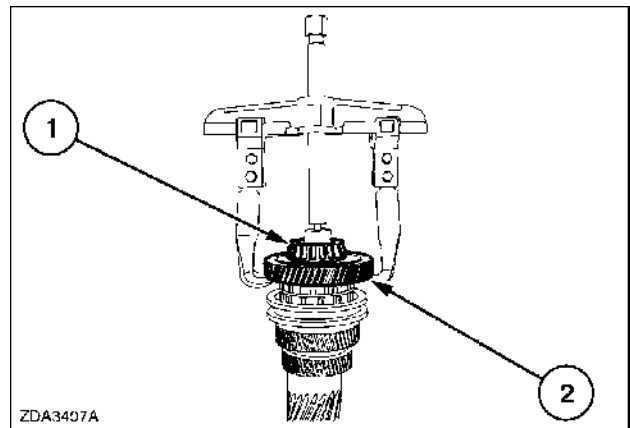

ZDA3407A 2

4. Remove needle bearings (1).
5. Remove selector ring (2) at the same time remove two balls (3) and the springs behind it.

NOTE: Balls (3) are spring-loaded, do not lose them.

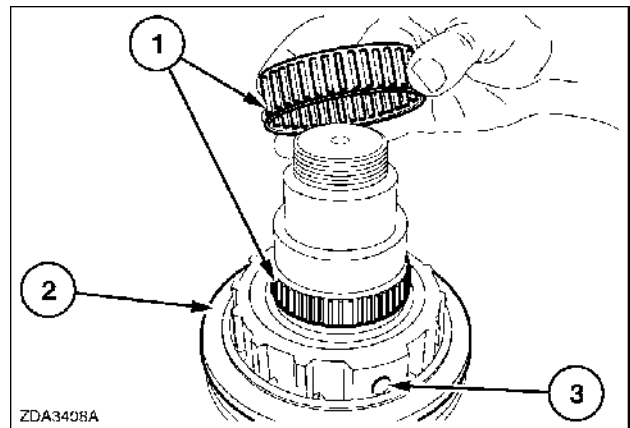

ZDA3408A 3

Front axle system - Final drives

- | | | |
|-------------------------------------|--------------------------------------|---|
| 1. Gear Reduction Unit | 20. Plastic Plug | 39. Tapered Roller Bearing |
| 2. M10 x 30mm, Hex Bolt | 21. Plug | 40. Plug |
| 3. M10 Bellville Washer | 22. Snap Ring, M92 | 41. Bolt, Hex Flange, M16 x 90mm |
| 4. Cover | 23. Locking Plate | 42. M16 Bellville Washer |
| 5. Seal | 24. Lock Nut, M100 x 2 | 43. Housing |
| 6. O-ring, 120mm ID x 5mm Width | 25. Tapered Roller Bearing | 44. O-ring, 500mm ID x 4mm Width |
| 7. Bearing | 26. Gear | 45. Splined Ring |
| 8. Driving Gear | 27. Snap Ring, M199.5, Internal. | 46. Shim Kit |
| 9. Drain Plug, M24 x 1.5 | 28. Gear | 47. Shims, 0.05mm Thick. 0.2mm Thick and 0.5mm Thick. |
| 10. Sealing Ring | 29. Snap Ring, M123.6 | 48. Plug |
| 11. Set Screw, Hex Socket, M16 x 30 | 30. Retainer | 49. Sealing Washer |
| 12. Housing | 31. Snap Ring, M50, External | 50. Hex socket screw |
| 13. Dowel | 32. Ring, M51.5 ID x 80 OD x 1 Thick | 51. Shim, 4.6mm Thick |
| 14. Cover | 33. Needle | 52. Shim, 4.65mm Thick |
| 15. Bolt, Hex, M10 x 1.5 x 20mm | 34. Planetary Gear | 53. Shim, 4.75mm Thick |
| 16. Locking Plate | 35. Pin | 54. Shim, 4.85mm Thick |
| 17. Locking Plate | 36. Seal | 55. Shim, 4.9mm Thick |
| 18. Lock Nut, M90 x 2 | 37. Wheel Bolt, M22 x 1.5 x 84 | |
| 19. Tapered Rolling Bearing | 38. Driven Shaft | |

Powered rear axle - Dynamic description

CR6.80 TIER 4B	NA
CR6.90	NA
CR7.90	NA
CR8.90	NA
CR9.90	NA

The powered rear axle (PRA) is available as a factory-installed or field-installed option. This system provides additional traction when the machine is operated in muddy or hilly field conditions. The system is engaged or disengaged electronically via the four-wheel drive engagement switch **(1)** switch on the right-hand console.

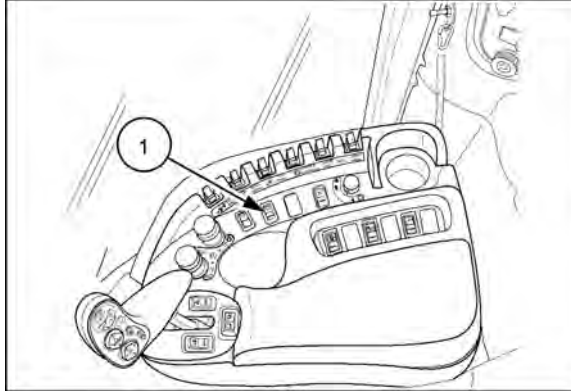

73074504 1

10. **⚠ WARNING**

Uncontrolled equipment movement!
For machines equipped with powered rear axle, the rear wheels MUST be clear from the ground.
Failure to comply could result in death or serious injury.

W1005A

Install pressure gauges (range **0-600 bar**) (**0-9000 psi**) to the hydrostatic pump test ports (**MA**) and (**MB**).

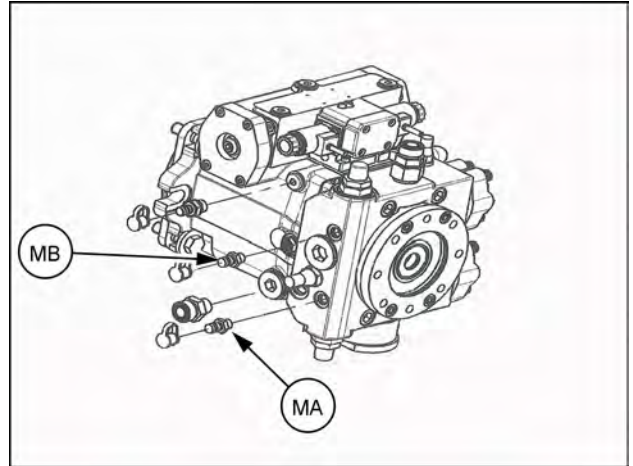

20075450A 9

11. Shift the transmission into neutral and crank the engine with the starter motor until a pressure gauge reading of **2.0 bar (29 psi)** is obtained.

NOTE: Only crank the engine for a maximum of **30 seconds** at a time. Wait at least **1 minute** before re-cranking to avoid damaging the starter motor.

12. Shift the transmission into 4th gear and hold the brake pedals down.
13. Move the hydrostatic lever slightly forward until the forward (**MB**) pressure gauge reading is a minimum of **50 bar (725 psi)** and a maximum of **400 bar (5800.0 psi)**. Do this for approximately **1 minute**.
14. Move the hydrostatic lever slightly rearward until the reverse (**MA**) pressure gauge reading is a minimum of **50 bar (725 psi)** and a maximum of **400 bar (5800.0 psi)**. Do this for approximately **1 minute**.
15. Release the brake pedals.

16. **⚠ WARNING**

Inhalation/asphyxiation hazard!
Never operate the engine in a closed building or area. Proper ventilation is required under all circumstances.
Failure to comply could result in death or serious injury.

W0303A

Check the oil level, add oil if necessary. Check for oil leaks.

17. Gearshift to neutral and engine speed on low idle. Position the hydrostatic lever at half stroke for **one minute**, both forward and reverse.
18. Gearshift remains in neutral and engine speed on high idle. Position the hydrostatic lever at maximum stroke for **two minutes**, both forward and reverse.
19. Gearshift to 4th gear and engine speed on high idle. Apply both brake pedals firmly. Apply maximum stroke on the control lever in forward position for a maximum of **10 seconds**. Pressure should be **420 - 460 bar (6092-6672 psi)**. Repeat the procedure for reverse.

The park brake caliper's normal condition is on, that is, clamped. Six heavy springs (two shown) (1) apply pressure against a piston (2), causing shaft (3) to push lever (4) to the left. The lever pivots at (5), forcing the left brake pad (6) toward the right brake pad (7), clamping the disc.

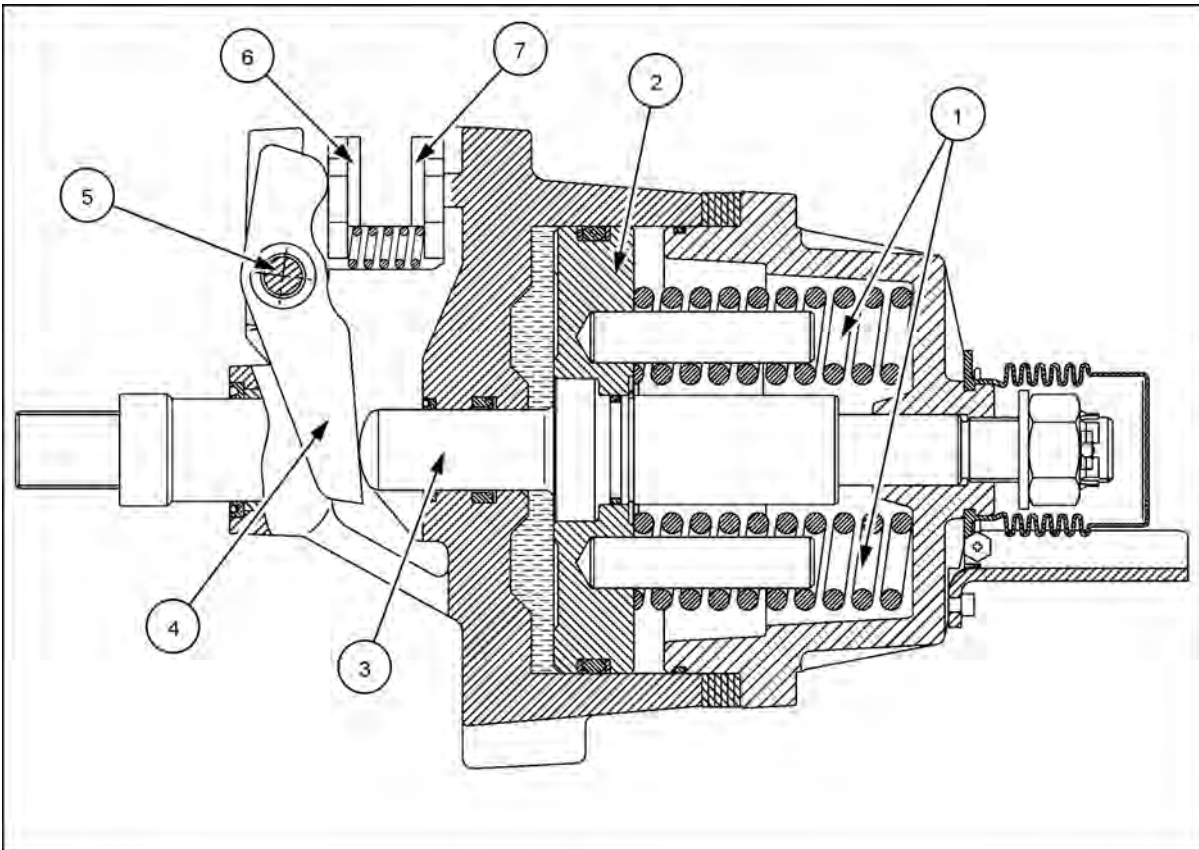

73080174 3

Figure 4, a view from underneath the brake caliper looking upward, shows the lever (1) and pivot braces (2). The shaft (3) pushes outward to move the lever.

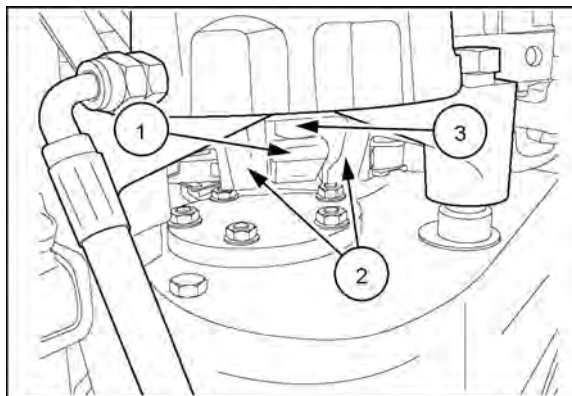

83080177 4

Hydraulic systems - Static description of the high pressure circuit

CR6.80	NA
CR6.90	NA
CR7.90	NA
CR8.90	NA
CR9.90	NA

The high pressure circuit operates all of the work hydraulics and steering. The circuit is fed by a closed center load sensing (CCLS) variable displacement pump, **(1)**, mounted on the engine gearbox. The pump draws oil from a cross that connects the main reservoir, cooler return and hydraulic return lines with the CCLS pump suction line. The CCLS pump pumps the oil through an in-line pressure filter to the main frame valve stack.

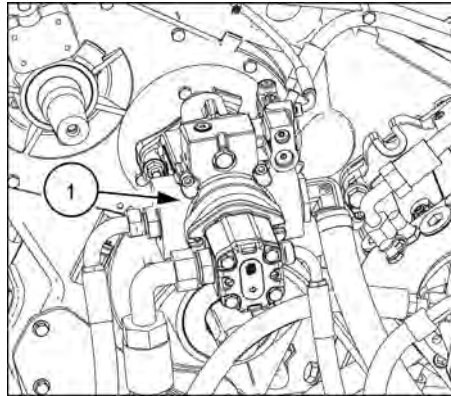

NHIL14CR00225AA 1

The oil enters the main frame valve stack at the priority valve section, **(1)**; this valve provides priority oil flow up to **35.0 L/min (9.2 US gpm)** to the steering circuit, and also contains the steering circuit relief valve. The secondary hydraulic functions in the main frame valve stack include the header height control valve, a header accumulator control valve, unloading auger swing, rotor variator valve, and feeder variator valve (if equipped).

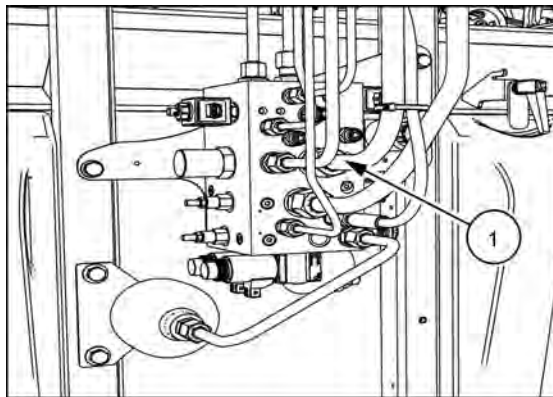

NHIL13CR00583AA 2

The steering motor, **(1)**, is mounted directly under the cab, and is connected to the bottom of the steering column. A fixed displacement steering motor is used for the North American market, while a variable displacement steering motor with shock relief valves is used in all other markets.

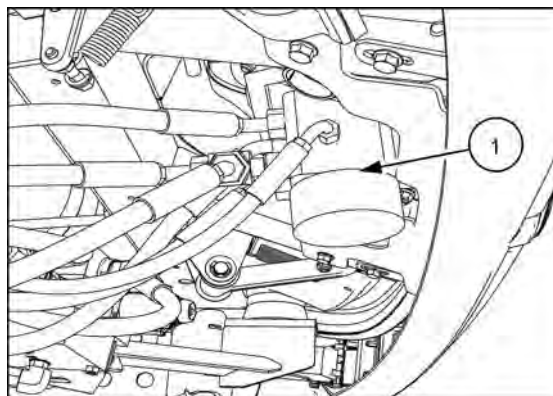

NHIL13CR00571AA 3

Oil reservoir - Drain fluid

CR6.80 TIER 4B	NA
CR6.90	NA
CR7.90	NA
CR8.90	NA
CR9.90	NA

NOTICE: Before the hydraulic oil is drained from the system, residual system pressure must be reduced to a minimum. Follow the instructions in the sequence given.

1. Detach the header from the combine. Refer to the Operator's Manual.
2. With the combine running, reduce the rotor and feeder speeds to minimum.

NOTE: Feeder speed control is optional.

3. Lower the feeder to its lowest position.
4. Assure that the unloading tube is in its full retracted position.
5. Turn off the combine engine.
6. Remove the drain hose (1) from the quick coupler and place the hose into a clean suitable container. Turn the center valve (2) to the ON position and drain the oil into the container. When system is drained, turn the valve to the OFF position and place the hose back into the coupler for storage.

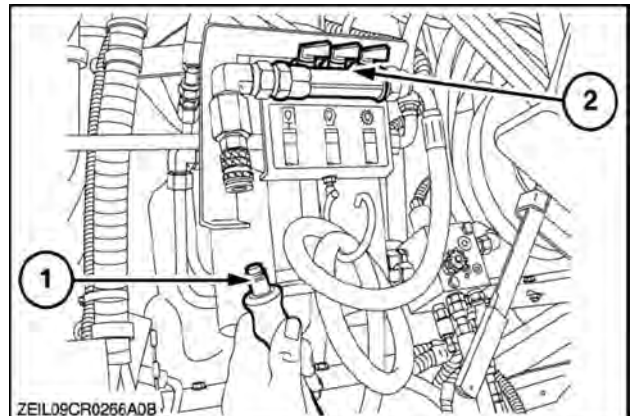

Traction variator system - Dynamic description - Theory of operation - Mechanical

The variator operating system is responsible for controlling speed of the rotor. The torque sensing drive sheave is a self-adjusting sheave that drives the right-hand rotor gearbox. It is driven by the variable drive sheave via a belt.

The torque sensing sheave uses two spring-loaded sheave halves on a hub to sense when the drive belt is slipping. If slippage occurs on the outer sheave half (rotor drive half), the inner sheave (driven half) will tighten to stop the slippage. The variator sheave forces the belt further out on the pulley as the speed increases. This adds tension to the belt. The torque sensing sheave will spread apart in response to the additional tension on the belt.

Variable drive feed control system

- The rotor adjust valve varies the position of a plunger in the rotor variable sheave (variator).
- The plunger is a hydraulic cylinder that operates a floating disc within the variator assembly to alter the belt speed.

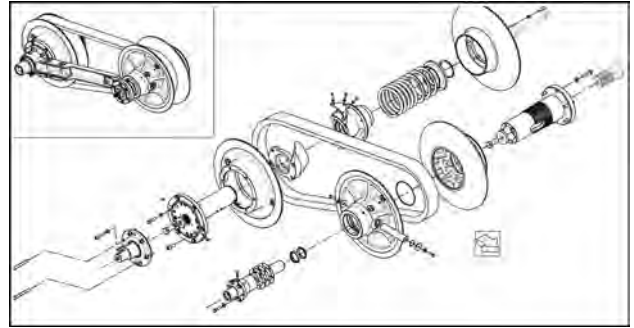

83117601A 1

Command valve - Replace Component

1. To replace the solenoid (1), remove the nut (2) and slide the solenoid off the valve shaft.
2. Install the new solenoid (1) and torque the nut (2) to **5 - 8 N·m (4 - 6 lb ft)**.

NOTICE: Do not over-torque the solenoid.

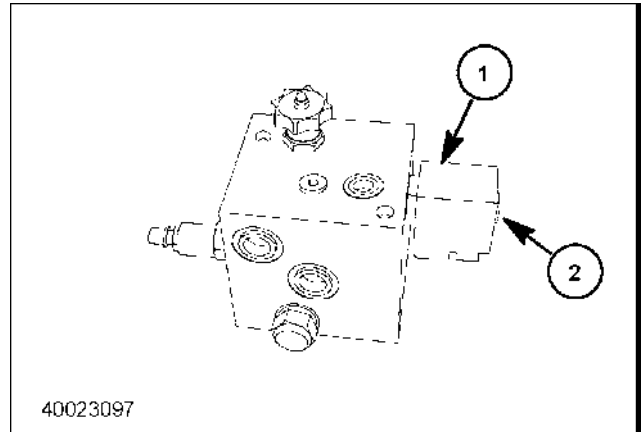

40023097 1

3. As necessary, replace the speed control valve (1), solenoid valve (2), check valve (3) and/or relief valve (4) by unscrewing them from the hydraulic block.

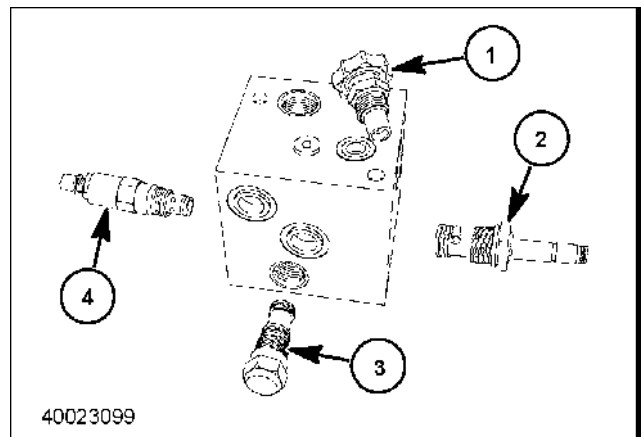

40023099 2

4. Make sure the O-rings are in good condition. Coat the O-rings with **NEW HOLLAND AMBRA MULTI G 134™ HYDRAULIC TRANSMISSION OIL** hydraulic fluid prior to installing any new valve in the hydraulic block.

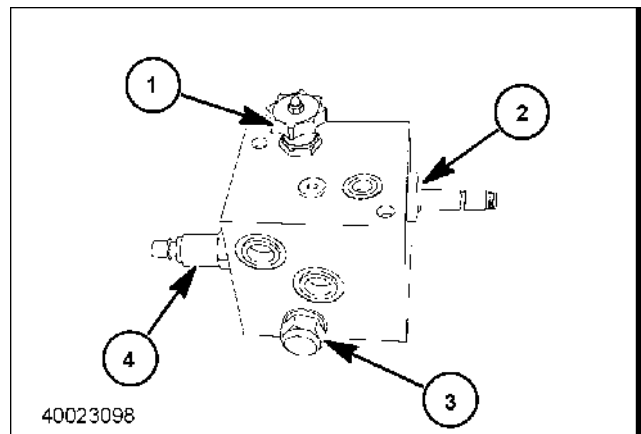

40023098 3

Autoguidance valve - General specification

CR6.80	NA
CR6.90	NA
CR7.90	NA
CR8.90	NA
CR9.90	NA

Nominal valve flow	30 l/min (8 US gpm)
Shock relief pressure	185 bar (2683 psi)
Maximum operating pressure	Port P 250 bar (3625 psi) Port R and S 20 bar (290 psi) Port A and B 280 bar (4060 psi)

Track support Isolation mount - Remove

Prior operation:

Rubber track - Remove (48.100)

1. Lower the combine until the roller wheels (1) contact the floor. DO NOT place any weight on the roller wheels.

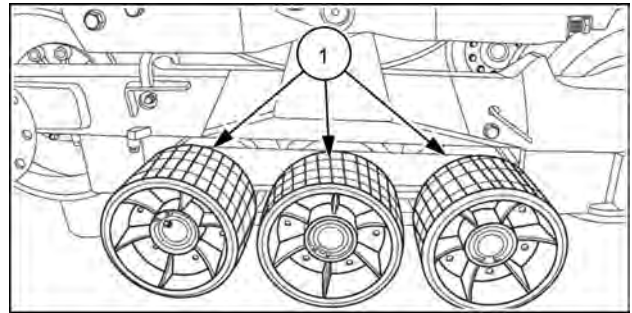

20085396 1

2. Remove the four M16 x 50 bolts and washers (1) from inside the idler tension axle pivot mount.

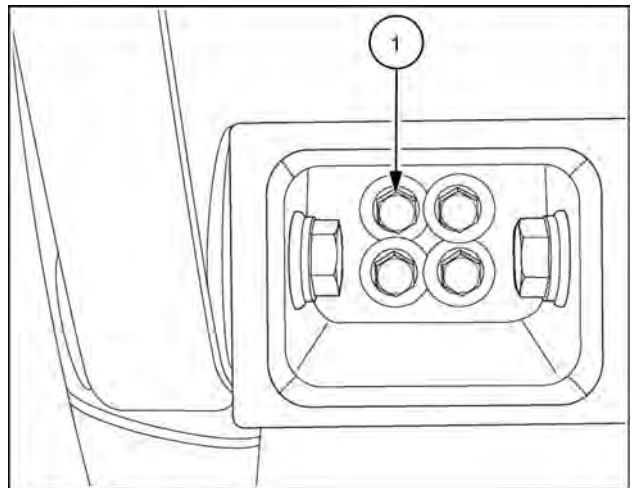

20085516 2

3. Remove the two M16 x 110 bolts (1) and two M16 x 180 bolts (2) from the isolator block.

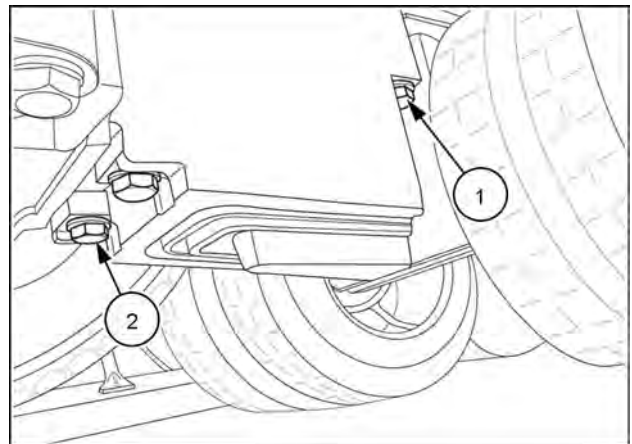

20085408 3

Idler wheel Axle - Assemble of Rear Idler Axle, Bearings and Seals

Prior operation:

Idler wheel Axle - Disassemble of Rear Idler Axle, Bearings and Seals (48.134)

1. Use a 112 mm (4.41 in) diameter bearing driver (1) to install both bearing cups in the hub or wheel until they are seated firmly against the inner shoulder (2) of the hub or wheel.

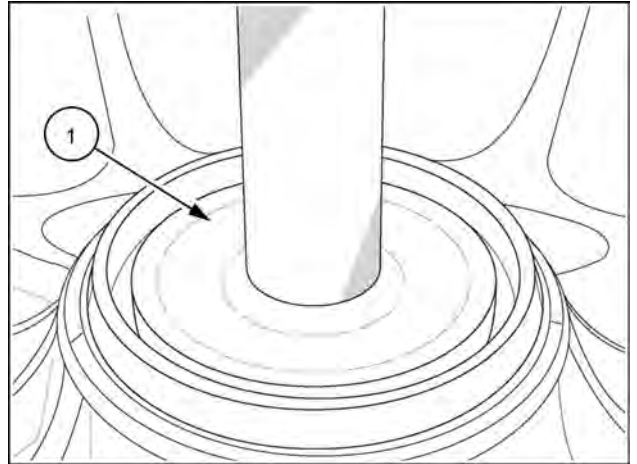

20085418 1

Preparation

NOTICE: Care should be taken at all times when handling metal face seals. The seal rings are made of extremely hard iron alloy. As a result, these rings are very brittle and must be handled with care. Never place the seal halves face down on any hard or abrasive surface.

NOTICE: In preparation for seal installation, the entire undercarriage must be thoroughly pressure washed or steamed cleaned. After disassembly, thoroughly wash and dry idler hubs, and seal cups with a water based cleaner externally as well as bearing and seal bores. Thoroughly flood internal bearing cups and seal bores with denatured alcohol. A pump type liquid dispenser works very well to apply denatured alcohol. (Highly evaporative electrical contract type cleaners are okay). Wipe using a lint free clean cloth. All parts must be free of dirt and grease. Inspect all parts for damage and replace any damaged parts found.

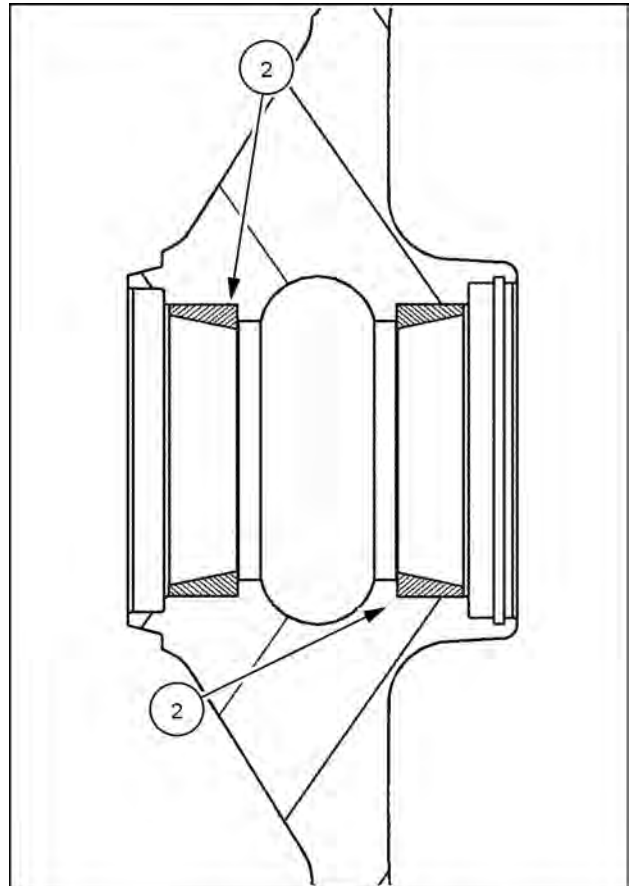

MA06D007 2

11. Pull the heater core assembly (1) from the housing.

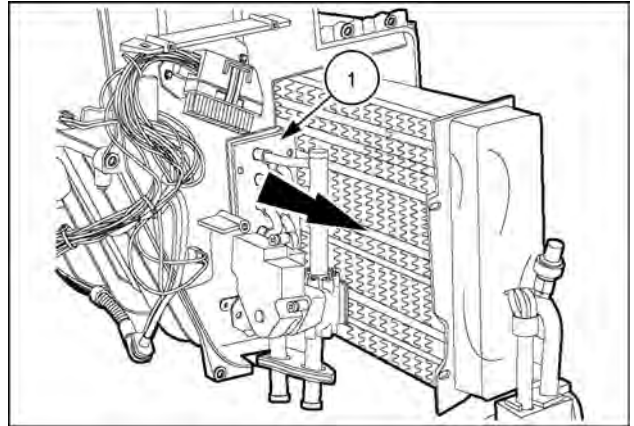

83082329 10

Next operation:
Heater core - Install (50.100).

Electrical system - Dynamic description Theory of operation – H-bridge circuit

All the devices included in the H-bridge circuit

- Control module
- Internal switches or relays
- Motors (or load)

Operation description

A H-bridge is an electronic circuit that enables a voltage to be applied across a load in either direction. The term 'H-bridge' was derived from the "H" shape schematic configuration.

Typically, a control module cannot deliver enough voltage to spin a motor in the forward direction or the reverse direction, therefore H-bridges are used. They are also used by the control module to block sudden voltage spike that occur when the motor direction or speed is changed, from the control module control lines.

The basic operation of a H-bridge can be best explained as:

- two (normally open) parallel switches, S1 and S3. These switches are connected to the positive terminals of a voltage source.
- two (normally open) parallel switches, S2 and S4. These switches are connected to the negative terminals of a voltage source.

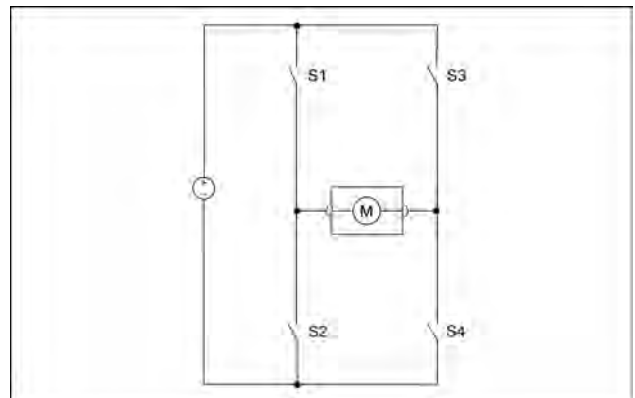

CIH13MRR(2) 1

The switches S1 and S3 are referenced as the "high side drivers". The other side of the S1 is connected to the positive terminal of the motor (or load) and the other side of the S3 is connected to the negative terminal of the motor (or load). (see figure above)

The switches S2 and S4 are reference as the "low side drivers". The other side of the S2 is connected to the positive terminal of the motor (or load) and the other side of the S4 is connected to the negative terminal of the motor (or load). (see figure above)

Forward direction

In order to spin the motor in the forward direction, switches S1 and S4 will close and create a closed loop causing positive voltage to flow across the motor.

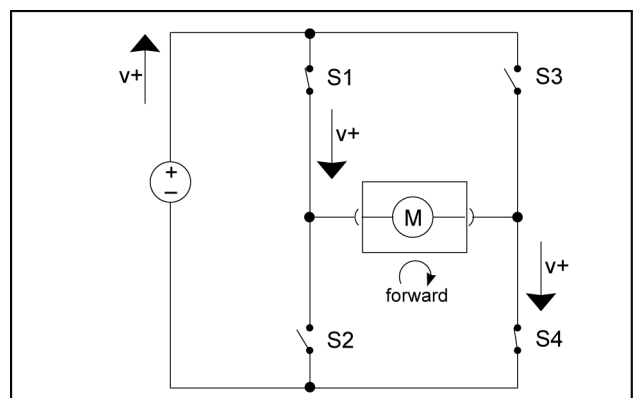

NHIL13CR00605AA 2

Electrical systems - Harnesses and connectors

Item	Connector	Wiring harness	Description
(1)	X-1037	Straw Hood Option (SHO)	Straw hood option to expansion harness connection
(2)	X-563B	Straw Hood Option (SHO)	Engine to threshing ground GND-003
(3)	X-501PB	Straw Hood Option (SHO)	Opti-Spread™ RPM change solenoid Y-457
(4)	X-1038	Straw Hood Option (SHO)	Straw hood option to active spreading harness connection
(5)	X-1038	Active Spreader (AS)	Straw hood option to active spreading harness connection
(6)	X-1035	Lower Frame Rear (LFR)	Lower frame rear to straw hood harness connection
(7)	X-206	Straw Hood Option (SHO)	Active spreader filter bypass B-206
(8)	X-033CN3	Straw Hood Option (SHO)	H-Bridge 3 A-033
(9)	X-033CN2	Straw Hood Option (SHO)	H-Bridge 3 A-033
(10)	X-033CN2	Straw Hood Option (SHO)	H-Bridge 3 A-033

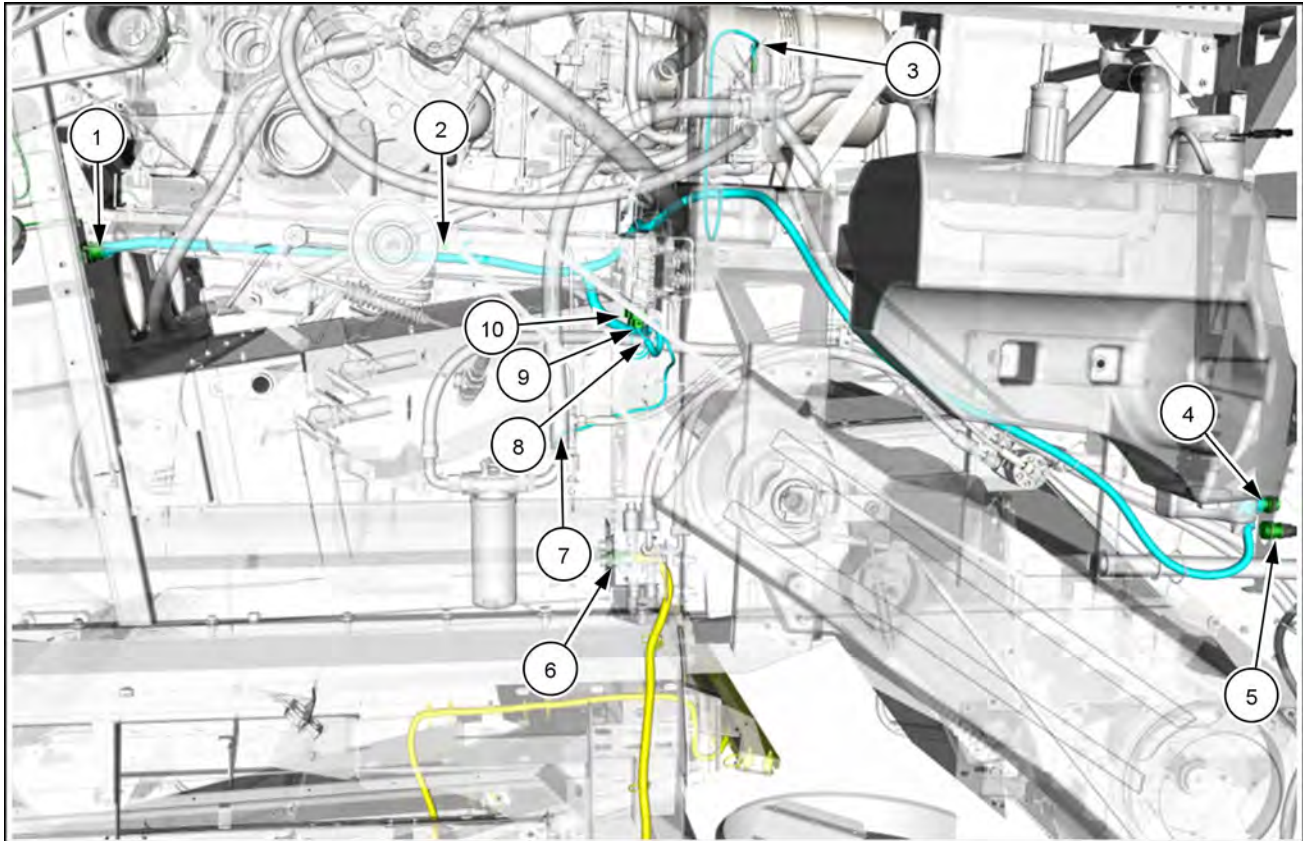

NHVM15CR00331JA 10

Wiring harnesses - Electrical schematic sheet 69 – Lights

Type	Component	Connector / Link	Description
ECU	A-002	X-002C3B X-002C3A X-002C2B X-002C2A X-002C1B X-002C4B X-002C4A X-002C1A	UCM-2
Lamp	E-356	X-356	ENGINE WORKLIGHT 87001315
Lamp	E-359	X-359	SIEVE LIGHT
Lamp	E-364	X-364	LHF SHIELD LIGHT 87001315
Lamp	E-365	X-365	LHR SHIELD LIGHT 87001315
Lamp	E-366	X-366	RH FRONT SHIELD LIGHT 87001315
Lamp	E-367	X-367	RH REAR SHIELD LIGHT 87001315
Fuse	F-040	X-902A	SHIELD LIGHTS
Fuse	F-041	X-902A	SIEVE/ENGINE LIGHTS
Fuse	F-042	X-902A	SPARE
Fuse	F-071	X-903A	SERVICE LIGHT SWITCHES
Relay	K-015	X-902B	SIEVE LIGHTS
Relay	K-016	X-902B	LH SHIELD LIGHTS
Relay	K-017	X-902B	SPARE
Relay	K-018	X-902B	ENGINE LIGHTS
Relay	K-019	X-902B	RH SHIELD LIGHTS
Relay	K-020	X-902B	SPARE
Switch	S-854	X-854	SIEVE LIGHT SWITCH
Switch	S-855	X-855	LH SHIELD LT SW
Switch	S-856	X-856	RH SHIELD LIGHT SWITCH
Switch	S-857	X-857	ENGINE LT SW
Connector	X-002C2A	X-002C2A	
Connector	X-002C2B	X-002C2B	
Connector	X-002C4B	X-002C4B	
Connector	X-1003	X-1003	
Connector	X-1014	X-1014	CAB TO RH MAIN FRAME (C)
Connector	X-1025	X-1025	CAB TO RH MAINFRAME (B)
Connector	X-1026	X-1026	CAB TO RH MAIN FRAME (A)
Connector	X-1031	X-1031	
Connector	X-1033	X-1033	
Connector	X-1043	X-1043	RH MAIN FRAME TO RH U/SHIELD LTS
Connector	X-1044	X-1044	LH MAIN FRAME-LH U/SHIELD LTS
Connector	X-1045	X-1045	CAB TO LH MAIN FRAME (A)
Connector	X-1046	X-1046	
Connector	X-1050	X-1050	
Connector	X-1104	X-1104	RH U/SHIELD LTS TO ENGINE WORK LIGHT
Connector	X-1140	X-1140	
Connector	X-356	X-356	ENGINE WORK LIGHT
Connector	X-359	X-359	
Connector	X-364	X-364	LHF SHIELD LT
Connector	X-365	X-365	LHR SHIELD LT
Connector	X-366	X-366	RHF SHIELD LT
Connector	X-367	X-367	RHR SHIELD LT
Connector	X-565B	X-565B	
Connector	X-773	X-773	
Connector	X-854	X-854	
Connector	X-855	X-855	
Connector	X-856	X-856	
Connector	X-857	X-857	
Connector	X-902A	X-902A	
Connector	X-902B	X-902B	
Connector	X-903A	X-903A	
Sub-Assembly	Z-D007		
Sub-Assembly	Z-D008		Diode
Sub-Assembly	Z-D009		Diode
Sub-Assembly	Z-D010		Diode
Sub-Assembly	Z-D011		Diode

Connector X-9017 - Engine decompression valve

CONNECTOR X-9017 - Engine decompression valve			
PIN NUMBER	WIRE NUMBER	CIRCUIT REFERENCE	ELECTRICAL SCHEMATIC FRAME
1	EN-244	Sensor ground	SHEET 06
2	EN-245	Sensor supply	

Connector X-9189-6CYL - Injector, cylinder 2

CONNECTOR X-9189-6CYL - Injector, cylinder 2			
PIN NUMBER	WIRE NUMBER	CIRCUIT REFERENCE	ELECTRICAL SCHEMATIC FRAME
1	EN-578-6CYL	Low side driver	SHEET 06
2	EN-579-6CYL	High side driver	

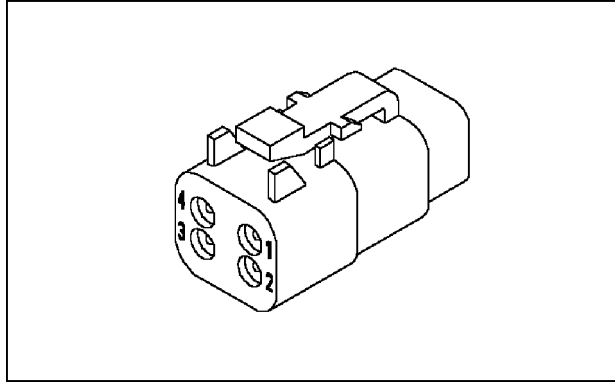

RC07CCH277904A1 121

Connector X-008. (277904A1)

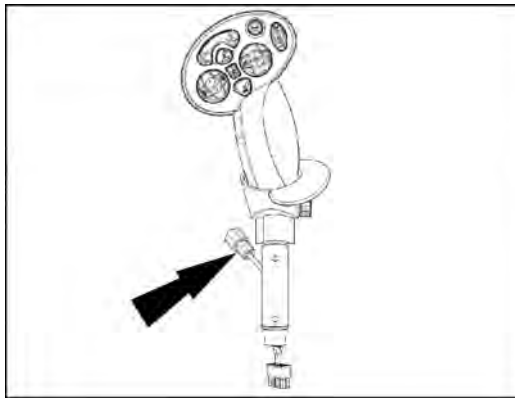

NHIL15CR00315AA 122

Connector X-008 is located at the bottom of the CommandGrip™.

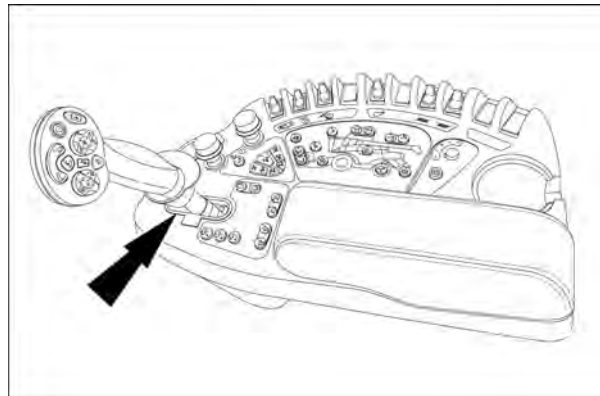

ZEIL14CR00056FA 123

Connector X-008 is located inside the right hand console.

Pin	From	Wire	Description	Color-Size	Frame
2	X-1122 (Male) pin 2 MFH INTERCONNECT	49	49	GN - 0.75	SHEET 74
3	X-1122 (Male) pin 3 MFH INTERCONNECT	48	48	BN - 0.75	
4	X-1122 (Male) pin 4 MFH INTERCONNECT	2	2	WH - 0.75	
5	X-1122 (Male) pin 5 MFH INTERCONNECT	50	50	YE - 0.75	

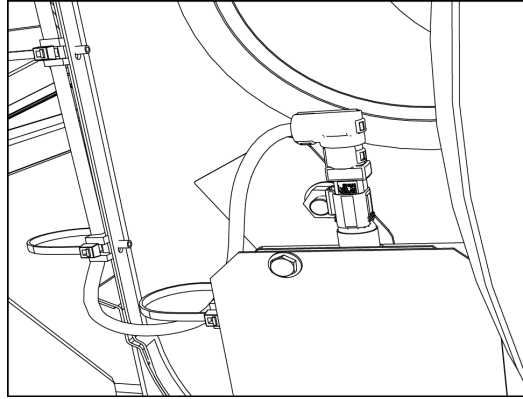

NHIL14CR00422AA 37

Connector X-118 is located near the grain elevator pulley system.

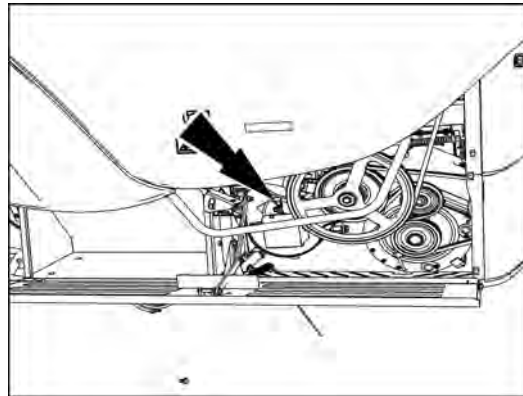

NHIL14CR00421AA 38

Connector X-118 is located on the right side of the machine.

Pin	From	Wire	Description	Color-Size	Frame
1	SP-501A-P-X	LMF-501AB	SENSOR GROUND UCM1	BL - 0.75	SHEET 36
2	X-1045 (Female) pin AC1 CAB TO LH MAIN FRAME (A)	LMF-450	SENSOR CLEAN GRAIN ELAVATOR RPM	YE - 0.75	

X-119 - CLEANING FAN RPM [B-119] (47414530) (Female)

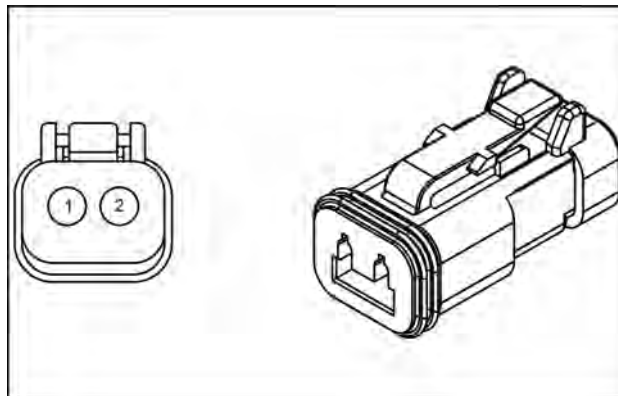

47414530 39

Connector X-119. (47414530)

X-203 - HYDRAULIC RESERVOIR LEVEL [B-203] (87692855) (Male)

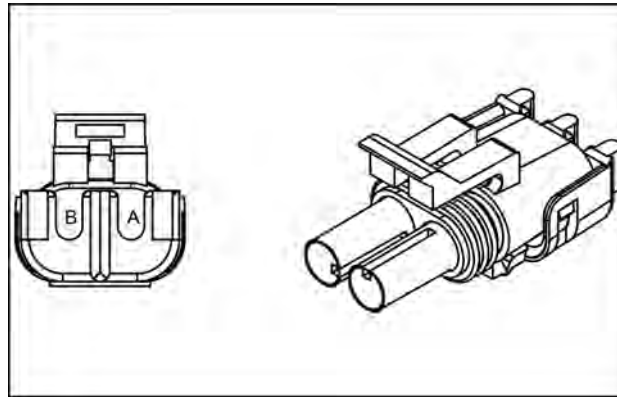

87692855 10

Connector X-203. (87692855)

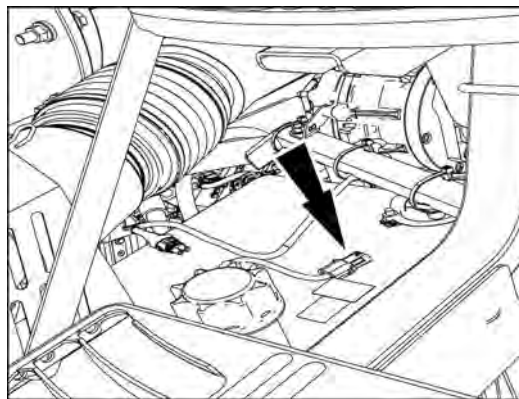

NHIL14CR00409AA 11

Connector X-203 is located near hydraulic reservoir.

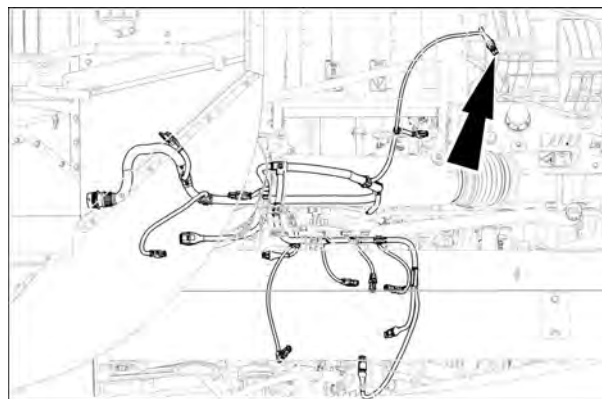

BAPH14CR00067FA 12

Connector X-203 is located next to the engine.

Pin	From	Wire	Description	Color-Size	Frame
A	X-561B (Male) pin 1	GB-487	GEARBOX CHASSIS GROUND	BK - 0.75	SHEET 37
B	X-1036 (Male) pin C MAIN FRAME EXPANSION TO GEARBOX	GB-424	SWITCH HYDRAULIC RESERVOIR LEVEL	YE - 0.75	

X-351 - RH PLATFORM FLASHER [E-351] (82012083) (Female)

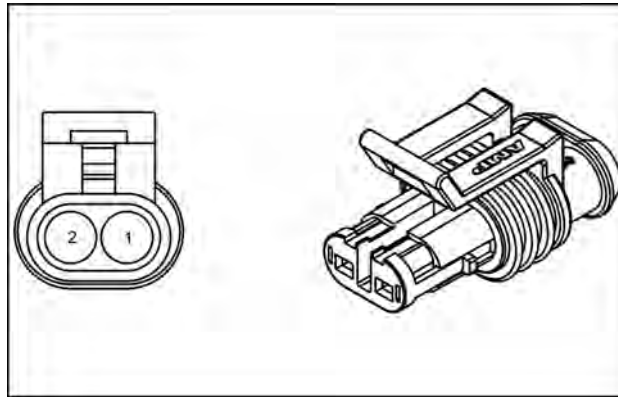

82012083 4

Connector X-351. (82012083)

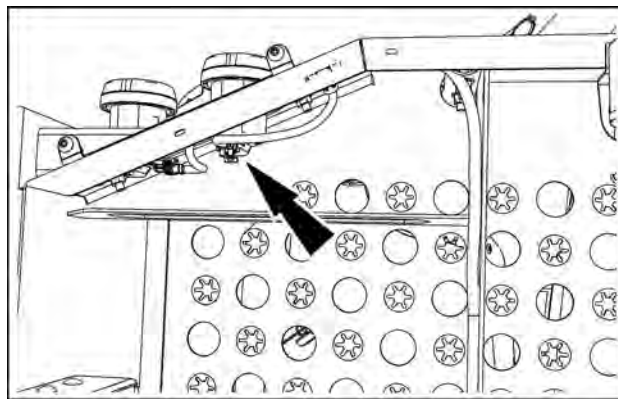

NHIL15CR00312AA 5

Connector X-351 is located left side of the right platform.

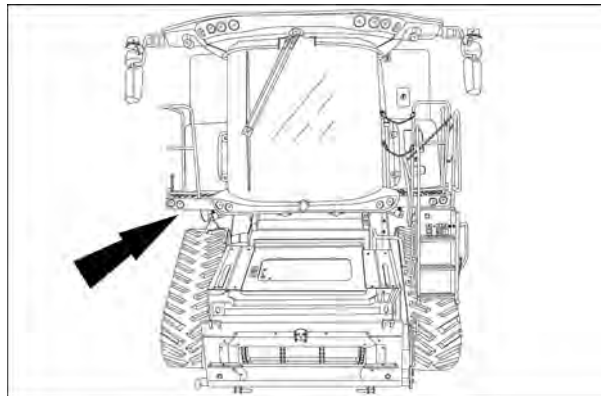

ZEIL14CR00069FA 6

Connector X-351 is located at the front of the machine.

Pin	From	Wire	Description	Color-Size	Frame
1	X-1060NASO (Female) CAB PLATFORM TO RH PLATFORM	MR-263D	FLASHER	VT - 0.75	SHEET 62
2	SP-053B-P-X	MR-053BA	CHASSIS GROUND	BK - 0.75	

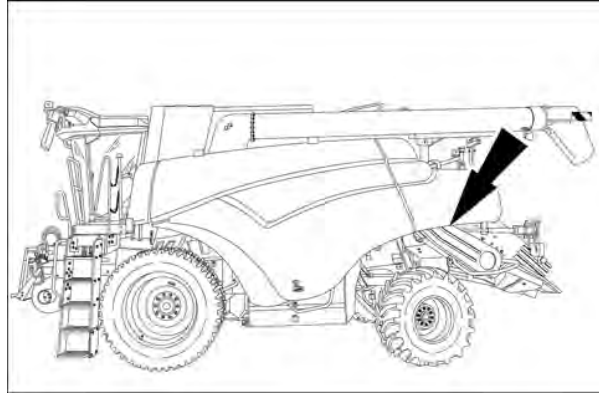

ZEIL14CR00130FA 19

Connector X-456 is located on the left side of the machine.

Pin	From	Wire	Description	Color-Size	Frame
1	X-1032 (Male) pin 17 EXT TO SHF (A)	SHE-576	SOLENOID CHAFF SPREADER	WH - 0.75	SHEET 45
2	SP-060E-P-X	SHE-060KA	CHASSIS GROUND	BK - 0.75	SHEET 17

X-457 - OPTI SPREAD RPM CHANGE SOLENOID [Y-457] (47414530) (Female)

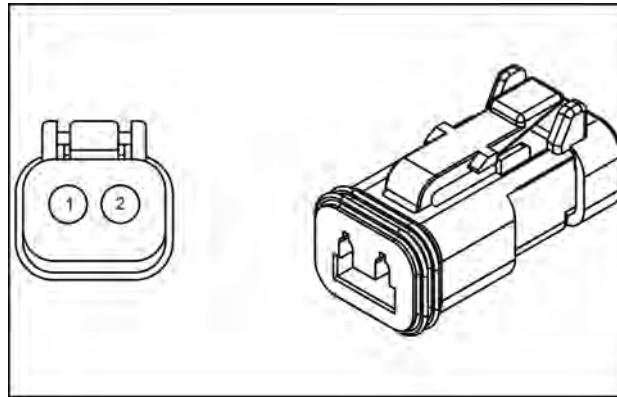

47414530 20

Connector X-457. (47414530)

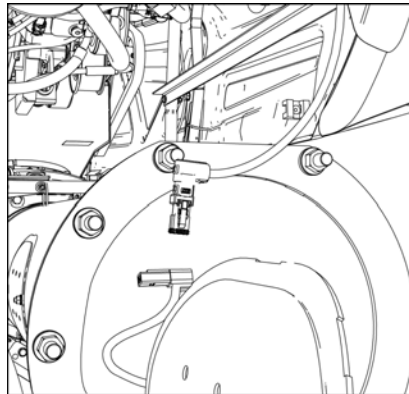

NHIL14CR00508AA 21

Connector X-457 is located next unloading tube inner fold.

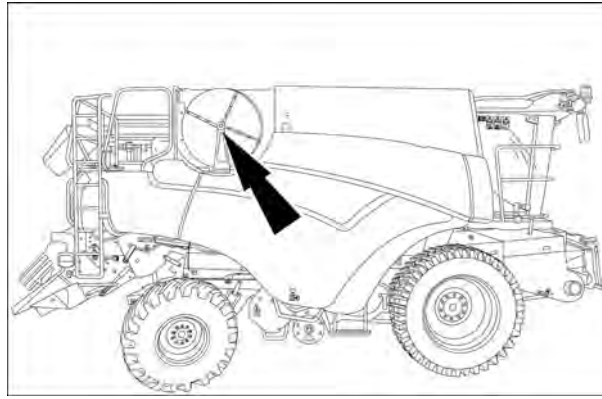

ZEIL14CR00129FA 4

Connector X-611B is located on the right side of the machine.

Pin	From	Wire	Description	Color-Size	Frame
A	SP-166A-P-X	BOD-166A	DOUBLE ROTARY BLOW-OFF	WH - 2.0	SHEET 25
B	SP-2142BA-P-X	BOD-LIN2142BB	LIN1	YE - 1.0	
C	SP-659CB-P-X	BOD-659CB	ENGINE GROUND	BK - 2.0	

X-612 - 2ND ROTARY SCREEN ACTUATOR [M-612] (87693690) (Female)

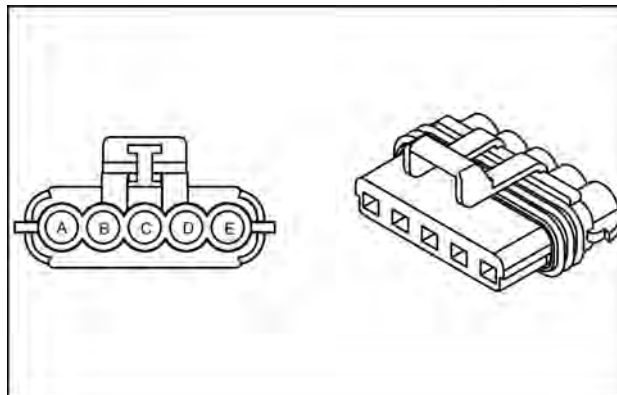

87693690 5

Connector X-612. (87693690)

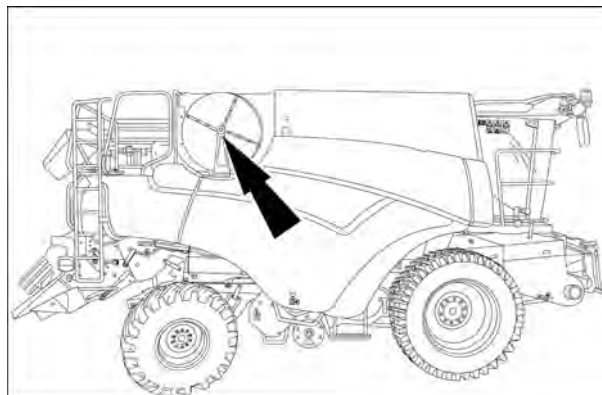

ZEIL14CR00129FA 6

Connector X-612 is located on the right side of the machine.

Pin	From	Wire	Description	Color-Size	Frame
A	SP-166A-P-X	BOD-169	DOUBLE ROTARY BLOW-OFF	WH - 2.0	SHEET 25
B	SP-2142BA-P-X	BOD-LIN2142BC	LIN1	YE - 1.0	
C	SP-659CB-P-X	BOD-659DA	ENGINE GROUND	BK - 2.0	

X-805 - CAB DISPLAY [S-805] (84159859) (Female)

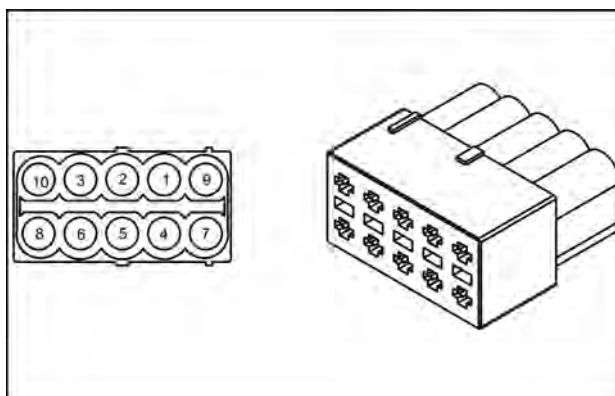

84159859 13

Connector X-805. (84159859)

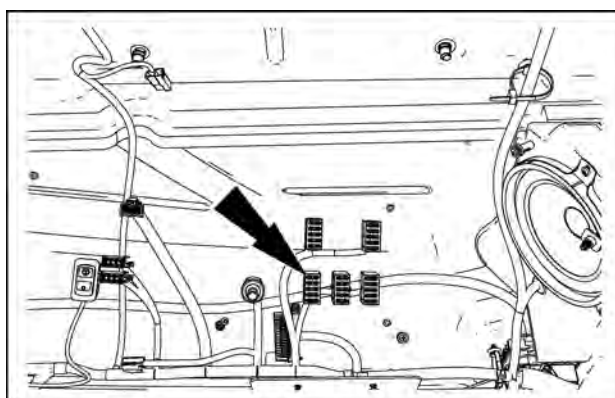

NHIL15CR00259AA 14

Connector X-805 is located in overhead console.

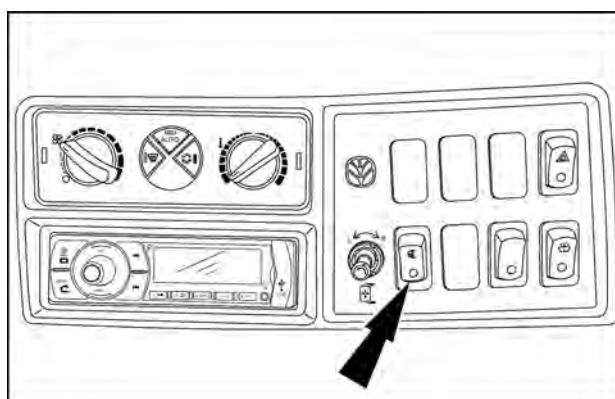

NHIL14CR00089AA 15

Connector X-805 is located in overhead console.

Pin	From	Wire	Description	Color-Size	Frame
2	SP-636-P-X	CRL-636C	SWITCHED B+ MIRROR HEAT	OR - 0.75	SHEET 73
3	X-1004 (Male) pin AB1 LOWER TO UPPER ROOF	CRL-931	MIRROR HEAT	WH - 0.75	
7	X-813 (Female) pin 7 FAR DISTANCE LIGHT	CRL-279AF	BACK LIGHT (+)	VT - 0.75	
9	X-813 pin 9 FAR DISTANCE LIGHT	CRL-052L	CHASSIS GROUND	BK - 0.75	

X-1003 - CAB MAIN HARNESS TO CAB LOWER ROOF HARNESS (87687229) (Female)

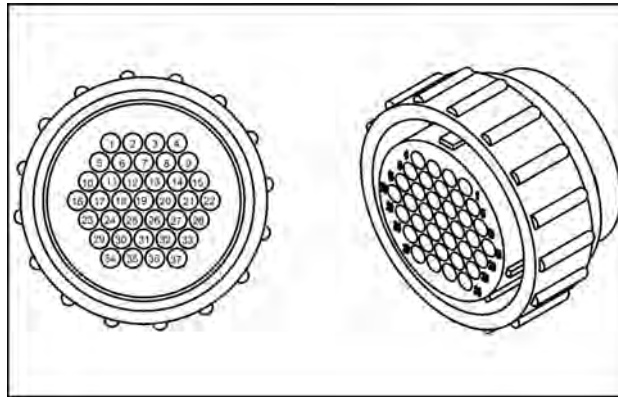

87687229 7

Connector X-1003. (87687229)

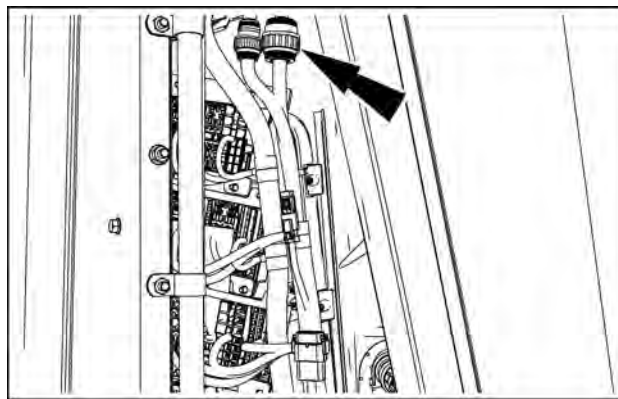

NHIL15CR00253AA 8

Connector X-1003 is located at the top right side of the cab roof.

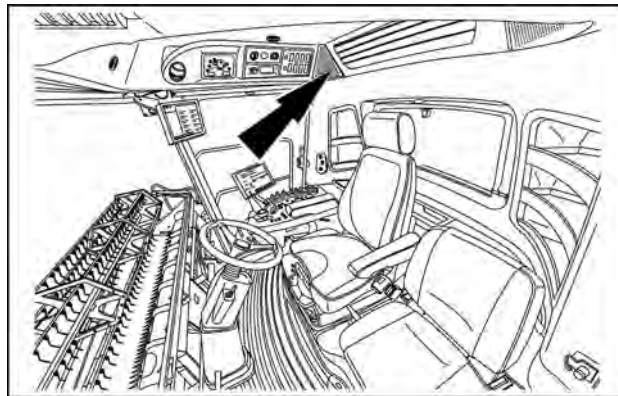

NHIL15CR00272AA 9

Connector X-1003 inside the cab roof.

Pin	From	Wire	Description	Color-Size	Frame
1	X-001C1A (Female) pin 13	CM-227	ROOF LTS CONTROL	WH - 0.75	
2	X-001C4B (Female) pin 12	CM-151	RELAY BEACON LIGHT	WH - 0.75	
3	X-002C2B (Female) pin 2	CM-2009	RELAY MIDDLE(FORWARD) LIGHTS	GY - 0.75	
4	SP-270B	CM-270B	RH MARKER LIGHTS	VT - 1.0	
5	SP-2032	CM-2032A	LIN2 SIGNAL	YE - 1.0	
6	SP-109	CM-109A	KEY SWITCHED	OR - 1.0	
7	X-1030 (Male) pin BA3	CM-650	RADIO KAPWR	RD - 0.75	
8	SP-291E-P-X	CM-291E	CAN2 HI	YE - 0.75	
9	SP-290E-P-X	CM-290E	CAN2 LO	GN - 0.75	
10	X-002C1B (Female) pin 33	CM-279	BACK LIGHT (+)	VT - 1.0	
11	X-903C PIN R1_86	CM-911	AC CLUTCH RELAY	WH - 0.75	
12	SP-253-P-X	CM-253	SWITCH HAZARD LIGHT	RD - 0.75	

Electrical systems - Harnesses and connectors

Pin	From	Wire	Description	Color-Size	Frame
AA5	X-1037 (Female) pin 2 EXTENSION TO STRAW HOOD EXTENSI	EX-726	+ 5V REF	PK - 0.75	SHEET 35
AA6	SP-401AA-P-X	EX-401AA	UCM1 SENSOR GROUND	BL - 0.75	SHEET 35
AA7	SP-109G-P-X	MFE-109G	MFE-109G	OR - 0.75	SHEET 06
AA8	SP-411-P-X	EX-411	UCM2 SENSOR GROUND	BL - 0.75	SHEET 43
AB2	X-1040 (Male) pin 21 EXTENSION TO ENGINE A	EX-1137	SWITCH FUEL CLOGGING	YE - 0.75	SHEET 45
AB3	X-1036 (Female) pin X MAIN FRAME EXPANSION TO GEARBOX	EX-1504	SOLENOID PROPULSION ENABLE(COR VALVE)	OR - 0.75	SHEET 41
AB4	X-1040 (Male) pin 8 EXTENSION TO ENGINE A	EX-864	AIR FILTER SWITCH	YE - 0.75	SHEET 45
AB5	X-1032 (Male) pin 18 EXT TO SHF (A)	EX-2100	PROTECTION SWITCHES	YE - 0.75	SHEET 36
AB6	X-1040 (Male) pin 20 EXTENSION TO ENGINE A	EX-1131	WATER IN FUEL SIGNAL	YE - 0.75	SHEET 20
AB7	X-1032 (Male) pin 13 EXT TO SHF (A)	EX-030D	BACK UP ALARM	OR - 1.0	SHEET 08
AB8	X-1032 (Male) pin 15 EXT TO SHF (A)	EX-569	REAR WHEEL ASSIST	WH - 0.75	SHEET 41
AC1	X-1036 (Male) pin P MAIN FRAME EXPANSION TO GEARBOX	EX-879	REVERSE(GOUND- SPEED HYDROSTAT	WH - 0.75	
AC2	X-1036 (Male) pin Q MAIN FRAME EXPANSION TO GEARBOX	EX-880	PROPULSION FORWARD GOUNDSPEED	WH - 0.75	
AC3	X-1032 (Male) pin 7 EXT TO SHF (A)	EX-447	SWITCH RETURN FILTER BYPASS	YE - 0.75	SHEET 37
AC4	X-1032 (Male) pin 8 EXT TO SHF (A)	EX-448	SWITCH PTO BOX FILTER	YE - 0.75	
AC5	X-1032 (Male) pin 22 EXT TO SHF (A)	EX-532A	SENSOR PSD RPM	YE - 0.75	SHEET 44
AC6	X-1036 (Female) pin E MAIN FRAME EXPANSION TO GEARBOX	EX-446	SENSOR HYD RESERVOIR TEMP	YE - 0.75	SHEET 37
AC7	X-1036 (Female) pin C MAIN FRAME EXPANSION TO GEARBOX	EX-424	SWITCH HYDRAULIC RESERVOIR LEVEL	YE - 0.75	
AC8	X-1036 (Female) pin B MAIN FRAME EXPANSION TO GEARBOX	EX-423	SENSOR LOW PRESSURE CONTROL	YE - 0.75	
AD1	X-1032 (Male) pin 9 EXT TO SHF (A)	EX-1055A	LEFT ENHANCED TURN/SIDE LIGHT	VT - 1.0	SHEET 68
AD3	X-1033 (Male) pin 17 EXT TO SHF (B)	EX-1309	CHAFF SPREADER RPM RIGHT	YE - 0.75	SHEET 38
AD4	X-1033 (Male) pin 18 EXT TO SHF (B)	EX-1310	LH CHAFF SPREADER RPM	YE - 0.75	
AD5	X-1037 (Male) pin 18 EXTENSION TO STRAW HOOD EXTENSI	EX-290H	CAN2 LO	GN - 0.75	SHEET 93
AD6	X-1037 (Male) pin 19 EXTENSION TO STRAW HOOD EXTENSI	EX-291H	CAN2 HI	YE - 0.75	
AD8	X-1040 (Male) pin 11 EXTENSION TO ENGINE A	EX-178	A/C COMPRESSOR CLUTCH	WH - 1.0	SHEET 88
BA1	X-1048 (Female) pin AB3 EXTENSION TO BATTERY BOX	EX-2097	RELAY MOTOR DUST OFF	GY - 0.75	SHEET 25
BA3	X-1048 (Female) pin B14 EXTENSION TO BATTERY BOX	EX-650	RADIO KAPWR	RD - 0.75	SHEET 75
BA5	X-1036 (Male) pin A MAIN FRAME EXPANSION TO GEARBOX	EX-422	SENSOR GEARBOX TEMP	YE - 0.75	SHEET 37
BA6	X-1036 (Male) pin M MAIN FRAME EXPANSION TO GEARBOX	EX-876	SOLENOID FDR CLUTCH	WH - 0.75	SHEET 33

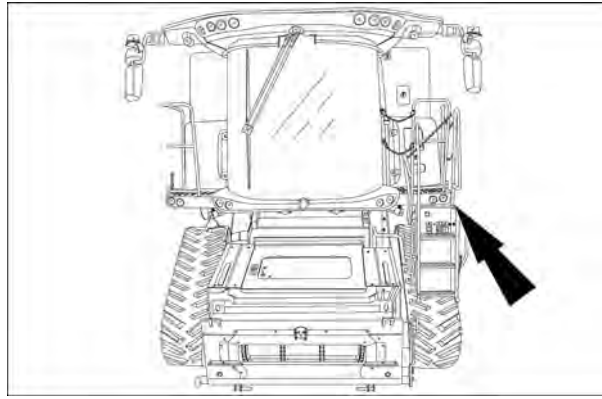

ZEIL14CR00069FA 47

Connector X-1059NASO is located at the front of the machine.

Pin	From	Wire	Description	Color-Size	Frame
1	X-1059EX (Female) pin 1 FRONT PLATFORM TO LHF HAZARD LTS	MLE-269AB	MLE-269AB	VT - 1.0	SHEET 06
2	X-1059EX (Female) pin 2 FRONT PLATFORM TO LHF HAZARD LTS	MLE-264D	MLE-264D	VT - 0.75	SHEET 63
3	X-1059EX (Female) pin 3 FRONT PLATFORM TO LHF HAZARD LTS	MLE-1055B	MLE-1055B	VT - 0.75	
4	X-1059EX (Female) pin 4 FRONT PLATFORM TO LHF HAZARD LTS	MLE-053C	MLE-053C	BK - 1.0	SHEET 61
5	X-1059EX (Female) pin 5 FRONT PLATFORM TO LHF HAZARD LTS	MLE-244BBL	MLE-244BBL	RD - 0.75	SHEET 63
6	X-1059EX (Female) pin 6 FRONT PLATFORM TO LHF HAZARD LTS	MLE-266	MLE-266	GY - 1.0	

***X-1059EX - MARKING LIGHT LEFT EXTENSION HARNESS TO MARKING LIGHT LEFT HARNESS (47416268)
(Female)***

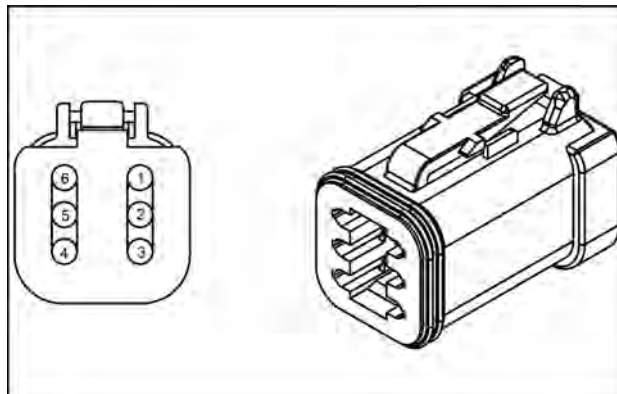

47416268 48

Connector X-1059EX. (47416268)

Pin	From	Wire	Description	Color-Size	Frame
1	X-639A (Male) pin 1 GRASS SHAKER MOTOR	GSM-2061	RELAY TO GRASS SHAKE MOTOR	OR - 2.0	SHEET 36
2	X-639B (Male) pin 1 GRASS SHAKER MOTOR	GSM-1848D	CHASSIS GROUND	BK - 2.0	

X-1122 - ARMREST CONTROL MODULE HARNESS TO MULTIFUNCTION HANDLE HARNESS (Female)

Pin	From	Wire	Description	Color-Size	Frame
2	X-004H1 (Male) pin 2	47	47	GN - 0.75	SHEET 74
3	X-004H1 (Male) pin 3	51	51	BN - 0.75	
4	X-004H1 (Male) pin 4	57	57	WH - 0.75	
5	X-004H1 (Male) pin 5	4	4	YE - 0.75	

X-1122 - MULTIFUNCTION HANDLE HARNESS TO ARMREST CONTROL MODULE HARNESS (Male)

Pin	From	Wire	Description	Color-Size	Frame
2	X-008 (Female) pin 2	49	49	GN - 0.75	SHEET 74
3	X-008 (Female) pin 3	48	48	BN - 0.75	
4	X-008 (Female) pin 4	2	2	WH - 0.75	
5	X-008 (Female) pin 5	50	50	YE - 0.75	

X-1124 - CAB ROOF UPPER HARNESS TO RH POWER MIRROR (47416269) (Female)

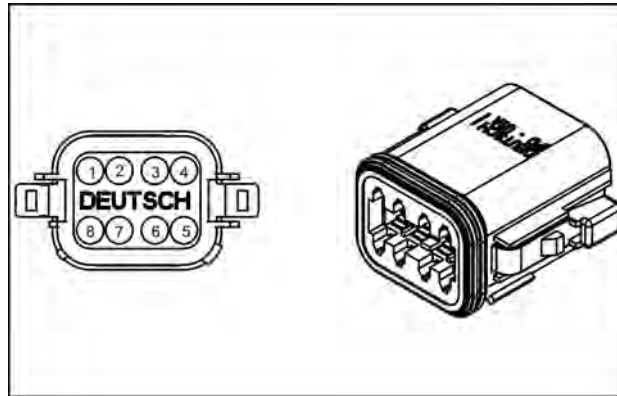

47416269 4

Connector X-1124. (47416269)

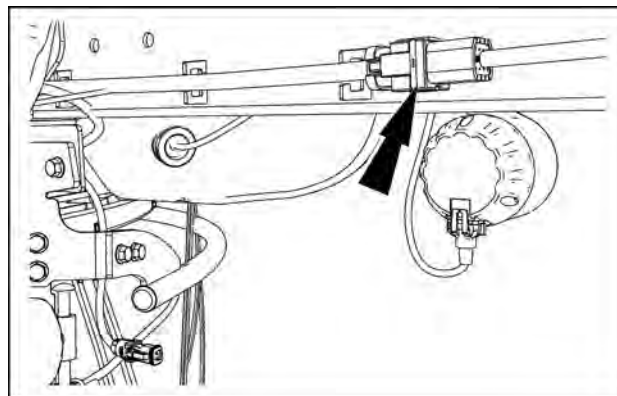

NHIL15CR00268AA 5

Connector X-1124 is located below the right exterior lights.

F-223 - SPARE

Component Type	Fuse
Wiring frames	SHEET 13

F-224 - SPARE

Component Type	Fuse
Wiring frames	SHEET 13

F-225 - SPARE

Component Type	Fuse
Wiring frames	SHEET 13

F-226 - SPARE

Component Type	Fuse
Wiring frames	SHEET 13

F-227 - SPARE

Component Type	Fuse
Wiring frames	SHEET 13

F-228 - SPARE

Component Type	Fuse
Wiring frames	SHEET 13

F-229 - SPARE

Component Type	Fuse
Wiring frames	SHEET 13

Index

Electrical systems - 55

Warning indicators, alarms, and instruments - 408

Instrument cluster - Dynamic description Theory of operation – Auto crop settings operation 3

- Disconnect the actuator connector (1) from the electrical harness (2).

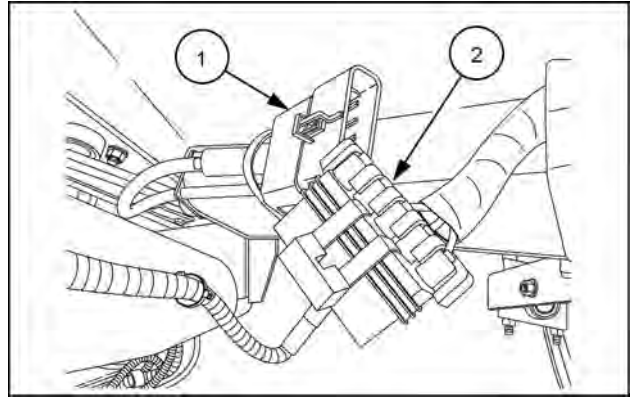

NHIL14CR00613AA 4

The LIN actuator tool. **380003394**

NOTE: The LIN actuator tool is wired to exclude the LIN bus wire.

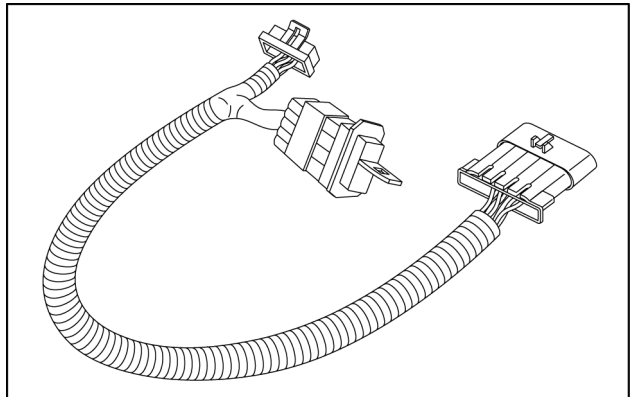

NHIL14CR00616AA 5

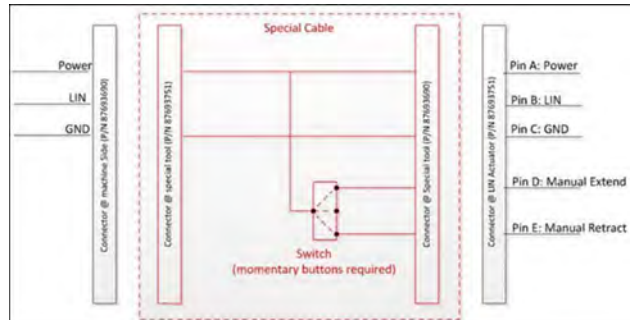

NHIL14CR00592AA 6



Electrical systems - 55

Selective Catalytic Reduction (SCR) electrical system - 988

**CR6.80 TIER 4B
CR6.90 TIER 4B
CR7.90 TIER 4B
CR8.90 TIER 4B
CR9.90 TIER 4B**

ATC-111- Cab sensor open or shorted to power

Control Module : ATC

NOTE: For more information concerning this fault, refer to the electrical schematic on sheets 88 and 89.

Context:

The Cab Temperature Sensor B-104 is used by the Automatic Temperature Control ATC to monitor the cab temperature.

Cause:

ATC has detected a short to high or an open condition in the cab temperature sensor signal circuit.

Possible failure modes:

1. Faulty sensor.
2. Faulty electrical wiring.
3. Faulty controller.

Solution:

1. Verify that the fault is present and active.
 - A. If the fault is present and active, continue to Step 2.
 - B. If the fault is not present and active, the fault may intermittent and not currently active. Continue to Step 6.
2. Verify that the cab temperature sensor functions properly.

Disconnect the sensor from the Cab Roof Lower (CRL) harness at connector X-104.

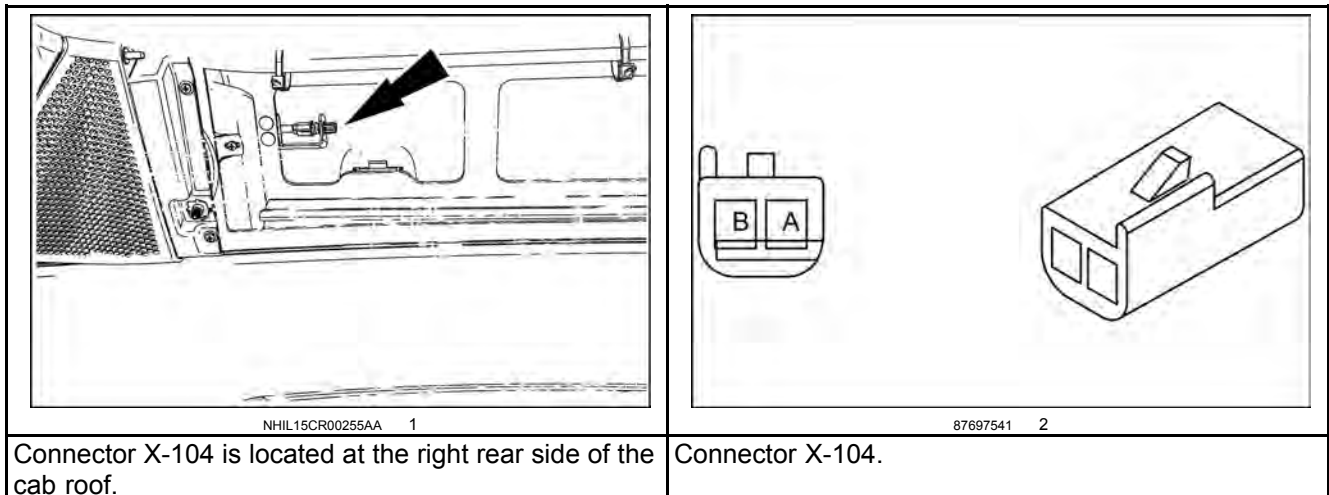

Use a multimeter to measure the resistance at pins A and B.

- A. If the resistance value is nominal, leave the connector X-104 disconnected and continue to Step 3.
- B. If the resistance value is **0 Ω** or infinite, the sensor has failed internally. Replace the sensor.
3. Check the signal circuit.

Use a multimeter to check for voltage:

From	To	Result
Cab Roof Lower (CRL) harness side of connector X-104 pin A	chassis ground	Should be approx. 5.2 V

DTC 1425-Fuel rail pressure sensor voltage is higher than expected

Control Module : ECU

Context:

For more information on the high pressure fuel system see **Injection control - Dynamic description (55.010)**. The Engine Control Unit (ECU) A-9000 monitors the fuel rail pressure sensor B-9004 signal circuit. If the ECU A-9000 determines that the voltage in the rail pressure sensor B-9004 signal circuit is higher than expected, this fault will occur.

Cause:

The ECU A-9000 has detected a value greater than **4.9 V** for period greater than **0.2 s**.

Possible failure modes:

1. Faulty rail pressure sensor B-9004 reference voltage, excessive.
2. Faulty rail pressure sensor B-9004, internal failure.
3. Faulty rail pressure sensor B-9004 signal circuit, short to high source or open circuit condition.
4. Faulty ECU A-9000, software.

Solution:

1. Verify fault is present and active.

Use the Electronic Service Tool (EST) to check the status of this fault.

A. If the fault is present and active, continue with Step 2.

B. If the fault is no longer present or in an inactive state, the fault may be intermittent and not currently active. Continue with Step 7.

2. Check for the following related faults:

DTC E42D - ECU internal failure - Sensor 5 volt supply 3

A. If the fault is active, resolve fault **DTC E42D - ECU internal failure - Sensor 5 volt supply 3**. Then determine that fault, **DTC 1425 - Fuel rail pressure sensor voltage is higher than expected** is also resolved.

B. If the fault is not active, continue to Step 3.

3. Check the rail pressure sensor B-9004 signal circuit for an open circuit condition.

Disconnect connector **X-9026**.

Disconnect connector **X-9002** from the ECU A-9000.

The key must be in the OFF position.

Use a multimeter to perform the following continuity check:

From	To	Value
X-9002 pin 36	X-9026-CUR pin 2	There should be continuity.

A. If there is continuity, leave the connectors disconnected and continue to Step 4.

B. If there is no continuity, there is an open circuit condition in the rail pressure sensor B-9004 signal circuit, wire EN-002. Locate and repair the broken conductor.

4. Check the rail pressure sensor B-9004 signal circuit for a short to high source condition.

The key must be in the OFF position.

Use a multimeter to perform the following continuity check:

DTC 1CBE-Downstream NO_x sensor self-diagnosis result is higher than the limit

Control Module : ECU

Context:

Self diagnosis is requested and performed during Engine Control Unit (ECU) A-9000 afterrun, as long as the SCR downstream NO_x sensor A-9102 reached dew point, the engine is stopped, and self diagnosis is not inhibited by another failure. If the value resulting from self diagnosis is above high limit (greater than **140 %**), this fault will occur. For information regarding the functional operation of the smart Selective Catalytic Reduction (SCR) downstream NO_x sensor A-9102 refer to **Nitrogen Oxides (NO_x) sensor - Dynamic description (55.988)**.

Cause:

The SCR downstream NO_x sensor A-9102 has too high positive drift.

Possible failure modes:

1. Faulty SCR downstream NO_x sensor A-9102, hardware or firmware.

Solution:

1. As there is no method for field testing or re-flashing the sensor controller, replace the SCR downstream NO_x sensor A-9102.

Then use the Electronic Service Tool (EST), refer to **Nitrogen Oxides (NO_x) sensor - Configure - Reset ECU data (Downstream sensor) (55.988)** if necessary, to perform the Replacement of Nox Downstream Sensor - Reset ECU Data configuration.

Then check to see that the fault is resolved.

- A. If the fault is resolved, return the machine to service.
- B. If the fault is not resolved, check the ECU A-9000 for the appropriate software and re-flash, if necessary.

4. Visually inspect the relevant harnesses and connectors for damage, bent or dislocated pins, corroded terminals, or broken wires. Verify that the connectors are fully installed. Flex the harnesses involved to reveal intermittent breaks or shorts in the wiring concerned. Operate the machine while you monitor the display.
 - A. If you find damage or the display indicates other than normal display readings, then repair the damage discovered during the inspection or locate and repair the other than normal display condition and verify that the error has been resolved.
 - B. If you do not find damage and the display indicates only normal readings, then erase the fault code and continue operation.

Wiring harnesses - Electrical schematic sheet 02 - Engine control unit (ECU) power and vehicle inputs/outputs (engine schematics) (55.100.DP-C.20.E.02)

- A. If you find damage or the display indicates other than normal display readings, then repair the damage discovered during the inspection or locate and repair the other than normal display condition and verify that the error has been resolved.
- B. If you do not find damage and the display indicates only normal readings, then erase the fault code and continue operation.

Wiring harnesses - Electrical schematic sheet 04 - Engine - Controller Area Network (CAN) (engine schematics) (55.100.DP-C.20.E.04)

DTC 49C3-Crankcase pressure too high for too long

Control Module : ECU

Context:

The Electronic Control Unit (ECU) A-9000 monitors crankcase pressure using the crankcase pressure sensor B-9009. If the A-9000 determines that crankcase pressure is too high for too long, this fault will occur.

Cause:

The difference in crankcase pressure to expected crankcase pressure has exceeded **16.06 cm H₂O (6.32 in H₂O)**.

Possible failure modes:

1. Faulty B-9009 wiring or internal failure.
2. Fuel in oil dilution.
3. Faulty fuel injectors, leaking.
4. Faulty piston rings.
5. Excessive turbocharger boost pressure.
6. Faulty A-9000, software.

Solution:

1. Use the Electronic Service Tool (EST) to check for the following related faults. If any of the faults are active, diagnose them first and then return to this fault, **DTC 49C3 - Crankcase pressure too high for too long**.

DTC 13A3 - Crankcase pressure sensor voltage is higher than expected

DTC 4AC3 - Crankcase pressure too high and oil pressure too low - Fuel in oil suspected

DTC 3DA3 - Crankcase pressure sensor value is not plausible

DTC 1338 - Over boost failure

DTC 1B48 - Overboost failure in engine brake mode

DTC 5614-Intake air heater actuator has an open load error

Control Module : ECU

Context:

The Engine Control Unit (ECU) A-9000 monitors the intake air heater relay K-9101 control circuit for an open load condition. If an open load condition is detected, this fault will occur.

Cause:

The ECU A-9000 has detected an open circuit condition in the intake air heater relay K-9101 control circuit.

Possible failure modes:

1. Faulty intake air heater relay K-9101, coil.
2. Faulty intake air heater relay K-9101, open circuit.
3. Faulty ECU A-9000, software.

Solution:

1. Verify fault is present and active.

Use the Electronic Service Tool (EST) to check the status of this fault.

A. If the fault is present and active, continue with **2**.

B. If the fault is no longer present or in an inactive state, the fault may be intermittent and not currently active. Continue with Step **4**.

2. Check the intake air heater relay K-9101 coil for an internal failure.

Remove the intake air heater relay K-9101.

Use a multimeter to test the intake air heater relay K-9101 coil.

From	To	Value
X-9116 pin 1	X-9116 pin 2	There should be between 70 - 130 Ω .

A. If the value is within the specified range, leave the intake air heater relay K-9101 removed and continue to Step **3**.

B. If the value is infinite, the intake air heater relay K-9101 has failed internally. Replace the intake air heater relay K-9101.

3. Check the intake air heater relay K-9101 for an open circuit condition.

Disconnect connector **X-9001** from the ECU A-9000.

The key must be in the OFF position.

Use a multimeter to perform the following continuity check:

From	To	Value
X-9001 pin 83	X-9116 pin 2	There should be continuity.

A. If there is infinite resistance, there is an open circuit condition in the intake air heater relay K-9101 signal circuit, wire VE-202. See the appropriate service manual to locate and repair the broken conductor.

B. If there is continuity, check the ECU A-9000 for the appropriate software and re-flash, if necessary.

4. Visually inspect the relevant harnesses and connectors for damage, bent or dislocated pins, corroded terminals, or broken wires. Verify that the connectors are fully installed. Flex the harnesses involved to reveal intermittent breaks or shorts in the wiring concerned. Operate the machine while you monitor the display.

8. Visually inspect the relevant harnesses and connectors for damage, bent or dislocated pins, corroded terminals, or broken wires. Verify that the connectors are fully installed. Flex the harnesses involved to reveal intermittent breaks or shorts in the wiring concerned. Operate the machine while you monitor the display.
 - A. If you find damage or the display indicates other than normal display readings, then repair the damage discovered during the inspection or locate and repair the other than normal display condition and verify that the error has been resolved.
 - B. If you do not find damage and the display indicates only normal readings, then erase the fault code and continue operation.

Wiring harnesses - Electrical schematic sheet 02 - Engine control unit (ECU) power and vehicle inputs/outputs (engine schematics) (55.100.DP-C.20.E.02)

Wiring harnesses - Electrical schematic sheet 06 - Fuel injection (engine schematics) (55.100.DP-C.20.E.06)

DTC 7522-Auxiliary power relay low side driver circuit short to ground failure

Control Module : ECU

Context:

The Engine Control Unit (ECU) A-9000 controls the voltage to the power relay K-9107. The ECU A-9000 monitors the K-9107 low side control circuit for a short to ground condition. If the ECU A-9000 detects a short to ground condition in the K-9107 low side circuit, this fault will occur.

Cause:

The ECU A-9000 has detected a short to ground condition in the K-9107 control circuit, low side.

Possible failure modes:

1. Faulty K-9107, internal short.
2. Faulty K-9107 low side control circuit, short to ground condition.
3. Faulty ECU A-9000, software.

Solution:

1. Verify fault is present and active.

Use the Electronic Service Tool (EST) to check the status of this fault.

A. If the fault is present and active, continue with **2**.

B. If the fault is no longer present or in an inactive state, the fault may be intermittent and not currently active. Continue with Step **4**.

2. Check the K-9107 coil for an internal failure.

Remove the K-9107.

Use a multimeter to check the K-9107 coil resistance.

From	To	Value
X-9124 pin 1	X-9124 pin 2	There should be between 70 - 130 Ω .

A. If the value is within the specified range, leave the K-9107 disconnected and continue with Step **3**.

B. If the value is not within the specified range, the K-9107 has failed internally. Replace the K-9107.

3. Check the K-9107 low side control circuit for a short to ground condition.

Remove the K-9107.

Disconnect connector **X-9001** from the ECU A-9000.

The key must be in the OFF position.

Use a multimeter to perform the following continuity check:

From	To	Value
X-9001 pin 45	Chassis ground	There should be no continuity.
X-9001 pin 45	All other pins	There should be no continuity.

A. If there is continuity, there is a short to ground condition in the K-9107 low side control circuit, wire VE-180. Locate and repair the shorted conductor.

B. If there is no continuity, check the ECU A-9000 for the appropriate software and re-flash, if necessary.

- A. If other faults do exist, use the appropriate vehicle service manual information to locate and repair the faulted CAN condition.
 - B. If no other faults exist, the vehicle (VE) or engine (EN) harness wiring is damaged between the network harness splice and the exhaust flap A-9001 actuator controller connector **X-9025 NEF pin 1** and/or **X-9025 NEF pin 2**, wire VE-218 or EN-049 and/or VE-189B or EN-050 for supply power and ground or **X-9025 NEF pin 4** and/or **X-9025 NEF pin 5**, wire VE-194B or EN-047 and/or VE-201F or EN-048A for CAN signal. Locate and repair the damage to the CAN circuit wiring.
5. As there is no method for field testing or re-flashing the sensor controller, replace the exhaust flap A-9001 actuator controller.

Then check to see that this fault is resolved.

- A. If this fault is resolved, return the machine to service.
 - B. If this fault is not resolved, check the ECU A-9000 for the appropriate software and re-flash, if necessary.
6. Visually inspect the relevant harnesses and connectors for damage, bent or dislocated pins, corroded terminals, or broken wires. Verify that the connectors are fully installed. Flex the harnesses involved to reveal intermittent breaks or shorts in the wiring concerned. Operate the machine while you monitor the display.
- A. If you find damage or the display indicates other than normal display readings, then repair the damage discovered during the inspection or locate and repair the other than normal display condition and verify that the error has been resolved.
 - B. If you do not find damage and the display indicates only normal readings, then erase the fault code and continue operation.

Wiring harnesses - Electrical schematic sheet 04 - Engine - Controller Area Network (CAN) (engine schematics) (55.100.DP-C.20.E.04)

DTC E28E-Downstream NOx sensor internal failure (Short Circuit Error)

Control Module : ECU

NOTE: Because this fault causes inducement, it is necessary to perform the SCR Fault Repair Verification Test once the fault has been resolved. See **Selective Catalytic Reduction (SCR) exhaust treatment - Service instruction - SCR fault repair verification test (10.500)** if necessary.

NOTE: Because this fault causes inducement, it is necessary to perform the Engine Restart Counter Reset / Unlock Inducement configuration with the Electronic Service Tool (EST) before you return the machine to service. See **Selective Catalytic Reduction (SCR) exhaust treatment - Configure - Engine restart counter reset (10.500)**, if necessary.

Context:

For information regarding the functional operation of the smart Selective Catalytic Reduction (SCR) downstream NO_x sensor A-9102 see **Nitrogen Oxides (NOx) sensor - Dynamic description (55.988)**. The SCR downstream NO_x sensor A-9102 has internal monitoring for open wire or short circuit and sends an error status in case of a detected failure. This failure is the result of a short circuit error in the sensor NO_x and/or Oxygen level circuit.

Cause:

The SCR downstream NO_x sensor A-9102 has reported, via CAN, to the ECU A-9000 that a short circuit condition exists in the NO_x and/or Oxygen level circuit.

Possible failure modes:

1. Faulty SCR downstream NO_x sensor A-9102, hardware or firmware.
2. Faulty ECU A-9000, software.

Solution:

1. Verify fault is present and active.

Use the Electronic Service Tool (EST) to check the status of this fault.

A. If the fault is present and active, continue with Step 2.

B. If the fault is no longer present or in an inactive state, the fault may be intermittent and not currently active. Continue with Step 3.

2. As there is no method for field testing or re-flashing the sensor controller, replace the SCR downstream NO_x sensor A-9102.

Then use the EST, refer to **Nitrogen Oxides (NOx) sensor - Configure - Reset ECU data (Downstream sensor) (55.988)**, if necessary, to perform the Replacement of Nox Downstream Sensor - Reset ECU Data configuration.

Then use the EST, see **Selective Catalytic Reduction (SCR) exhaust treatment - Configure - Engine restart counter reset (10.500)**, if necessary, to perform the Engine Restart Counter Reset / Unlock Inducement configuration.

Then perform the SCR Fault Verification Test, see **Selective Catalytic Reduction (SCR) exhaust treatment - Service instruction - SCR fault repair verification test (10.500)**, if necessary.

Then check to see that this fault is resolved.

A. If this fault is resolved, return the machine to service.

B. If this fault is not resolved, check the ECU A-9000 for the appropriate software and re-flash, if necessary.

3. Visually inspect the relevant harnesses and connectors for damage, bent or dislocated pins, corroded terminals, or broken wires. Verify that the connectors are fully installed. Flex the harnesses involved to reveal intermittent breaks or shorts in the wiring concerned. Operate the machine while you monitor the display.

CLICK HERE TO **DOWNLOAD** THE COMPLETE MANUAL

- Thank you very much for reading the preview of the manual.
- You can download the complete manual from: www.heydownloads.com by clicking the link below



- Please note: If there is no response to CLICKING the link, please download this PDF first and then click on it.

CLICK HERE TO **DOWNLOAD** THE COMPLETE MANUAL

DTC ED2D-CAN communication failure - External torque/speed checksum and counter

Control Module : ECU

Context:

The Engine Control Unit (ECU) A-9000 is capable of connecting to and communicating on three separate Controller Area Networks (CAN). Proper configuration and monitoring of the three twisted pair configured networks is also a function of the ECU A-9000. CAN Node A Bus is the main vehicle interface bus. The ECU A-9000 provides a CAN termination resistor for the CAN Node A Bus, internal to the ECU A-9000. The ECU A-9000 provides checksum and counter functionality to assure torque/speed message integrity and completeness. If the ECU A-9000 senses an error in the rolling counter and checksum of the torque/speed message, this fault will occur.

Cause:

ECU A-9000 has sensed an error in the rolling counter and checksum of the torque/speed message.

Possible failure modes:

1. Faulty vehicle system, related CAN fault.
2. Faulty supply voltage or ground, missing.
3. Faulty CAN circuit wiring, open circuit, short to ground, or short circuit.
4. Faulty ECU A-9000, termination resistor or software.

Solution:

1. Verify fault is present and in active state.

Use the Electronic Service Tool (EST) to check the status of this fault.

A. If the fault is present and active, continue with Step 2.

B. If the fault is no longer present or is in an inactive state, the fault may be intermittent and not currently active. Continue with Step 6.

2. Check for related vehicle CAN faults.

Use the EST to determine if related vehicle CAN faults exist.

A. If related vehicle CAN faults do exist, resolve the vehicle CAN faults, then check to see that **DTC ED2D - CAN communication failure - External torque/speed checksum and counter** is also resolved.

B. If related vehicle CAN faults do not exist, continue with Step 3.

3. Check the ECU A-9000 supply voltage.

Disconnect the vehicle (VE) harness from the ECU A-9000 at connector **X-9001**.

With the key switch in the "ON" position, use a multimeter to check for voltage on the vehicle (VE) harness side:

From	To	Value
X-9001 pin 1	chassis ground	There should be 12.0 V .
X-9001 pin 25	chassis ground	There should be 12.0 V .
X-9001 pin 26	chassis ground	There should be 12.0 V .
X-9001 pin 49	chassis ground	There should be 12.0 V .
X-9001 pin 73	chassis ground	There should be 12.0 V .

A. If the voltage is present on all of the checks, leave connector **X-9001** disconnected and continue with Step 4.

B. If the voltage is not present for one or more of the checks, refer to the appropriate vehicle service manual and electrical schematics to locate and restore supply power to the ECU A-9000.

- A. If you find damage or the display indicates other than normal display readings, then repair the damage discovered during the inspection or locate and repair the other than normal display condition and verify that the error has been resolved.
- B. If you do not find damage and the display indicates only normal readings, then erase the fault code and continue operation.

E0043-03-Up/down Active Spreading Actuator - Shorted to high source

Control Module : UCM1

Context:

The Universal Control Module 1 (UCM1) monitors the operation of the up/down active spreading actuator M-624.

Cause:

UCM1 is sensing a signal level greater than **5.2 V** in the up/down active spreading actuator signal circuit.

Possible failure modes:

1. Faulty sensor.
2. Faulty electrical wiring shorted to voltage source.
3. Faulty module.

Solution:

1. Verify that the fault is present and active.

Use the display monitor diagnostic capability to view parameter status to check the voltage level.

For additional information about the monitor diagnostic capability, see **Electrical system - Dynamic description Theory of operation – Display monitor diagnostic screens (55.000)**.

A. If the voltage reading is greater than **5.2 V**, continue to Step 2.

B. If the voltage reading is less than **5.2 V**, the fault may intermittent and not currently active. Continue to Step 6.

2. Verify that the sensor functions properly.

Disconnect the sensor from the Active Spreading (AS) harness at connector X-624.

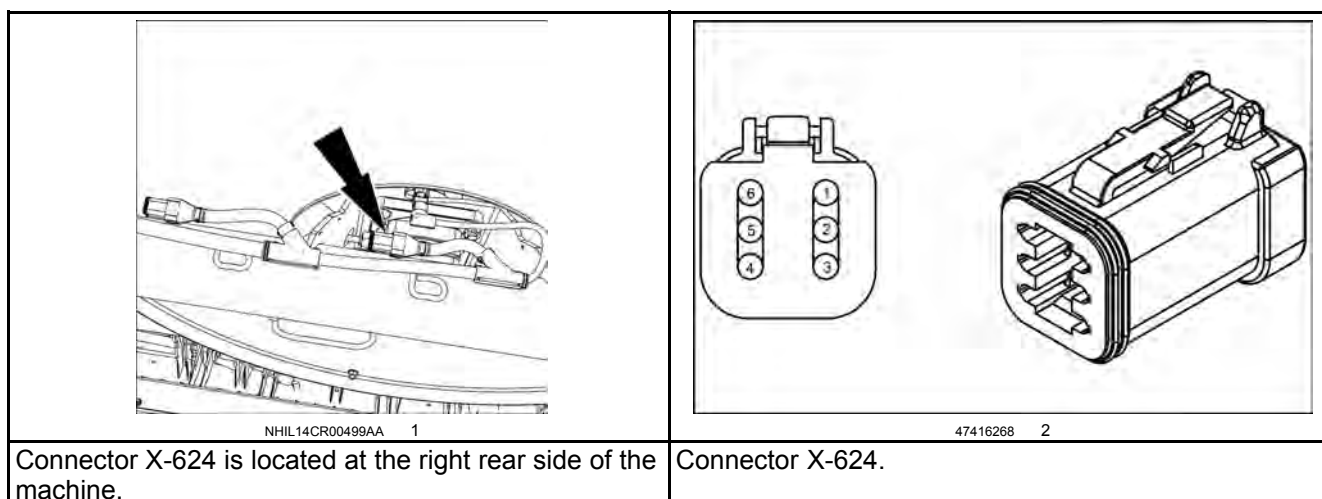

Check for other fault codes on the display monitor.

- A. If fault code **E0043-05 - Up/down Active Spreading Actuator - Line disconnected** is present, the sensor has failed internally. And the circuit wiring is functioning properly. Replace the sensor.
- B. If fault code **E0043-03 - Up/down Active Spreading Actuator - Shorted to high source** is still present, continue to Step 3.

3. Check the circuit wiring.

E0061-03-Gearbox Temperature Sensor - Shorted to high source

Control Module : UCM1

NOTE: For information concerning this fault, refer to sheet 37.

Context:

The Universal Control Module 1 (UCM1) monitors the operation of the gearbox temperature sensor B-173.

Cause:

UCM1 is sensing a signal level greater than **5.0 V** in the gearbox temperature sensor signal circuit.

Possible failure modes:

1. Faulty sensor.
2. Faulty electrical wiring shorted to voltage source.
3. Faulty module.

Solution:

1. Verify that the fault is present and active.

Use the display monitor diagnostic capability to view parameter status to check the voltage level.

For additional information about the monitor diagnostic capability, see **Electrical system - Dynamic description Theory of operation – Display monitor diagnostic screens (55.000)**.

A. If the voltage reading is greater than **8.2 V**, continue to Step 2.

B. If the voltage reading is less than **8.2 V**, the fault may intermittent and not currently active. Continue to Step 6.

2. Verify that the sensor functions properly.

Disconnect the sensor from the Gearbox (GB) harness at connector X-173.

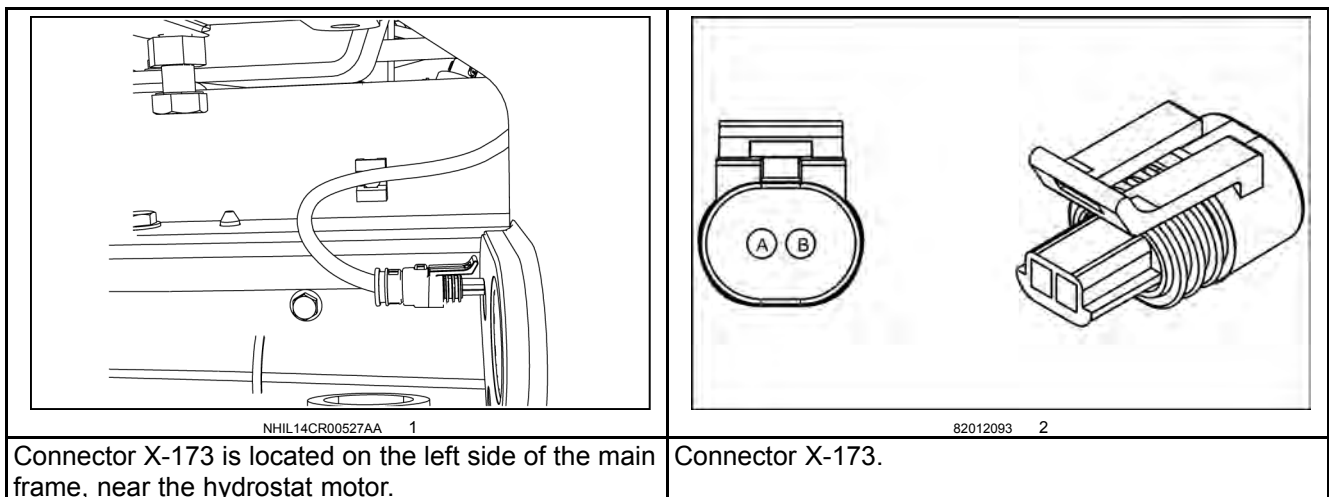

Check the display monitor for other fault codes.

- A. If fault code **E0061-03 - Gearbox Temperature Sensor - Shorted to high source** is still present, continue to Step 3.
- B. If fault code **E0061-05 - Gearbox Temperature Sensor -Line disconnected** is present, the circuit wiring functions properly. However, the sensor has failed internally. Replace the sensor.
3. Check for a short to high condition.

- B. If the circuit test fails, there is a faulty wire between connector X-001C4B pin 31 and connector X-167 pin C, wire 722 yellow. Locate the faulty wiring. Repair the faulty wiring.
- 6. Visually inspect the relevant harnesses and connectors for damage, bent or dislocated pins, corroded terminals, or broken wires. Verify that the connectors are fully installed. Flex the harnesses involved to reveal intermittent breaks or shorts in the wiring concerned. Operate the machine while you monitor the display.
 - A. If you find damage or the display indicates other than normal display readings, then repair the damage discovered during the inspection or locate and repair the other than normal display condition and verify that the error has been resolved.
 - B. If you do not find damage and the display indicates only normal readings, then erase the fault code and continue operation.

- A. If you find damage or the display indicates other than normal display readings, then repair the damage discovered during the inspection or locate and repair the other than normal display condition and verify that the error has been resolved.
- B. If you do not find damage and the display indicates only normal readings, then erase the fault code and continue operation.

Place the key switch in the OFF position.

Disconnect the Cab Roof Lower (CRL) harness from UCM at connector X-001C4B.

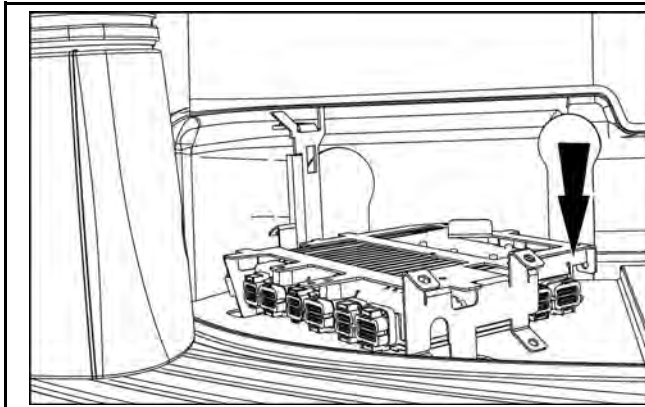

NHIL13AF00020AA 3

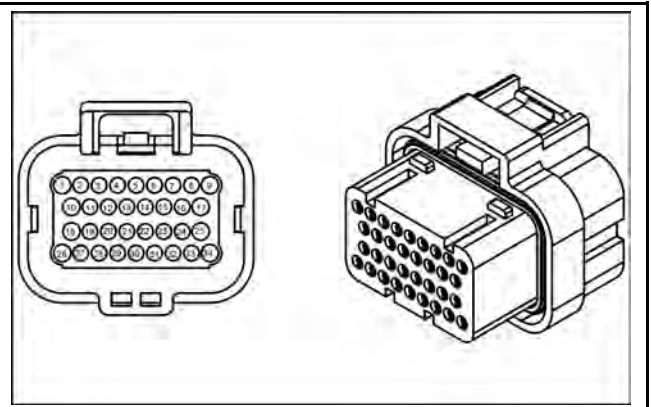

82028495 4

Connector X-001C4B is located under the right hand console.

Connector X-001C4B.

Use a multimeter to check for continuity:

From	To	Result
Cab Roof Lower (CRL) harness side of connector X-901C pin R2_85	Cab main (CM) harness at connector X-001C4B pin 12	Should be continuity

- A. If the circuit wiring test fails, there is a faulty wire between connector X-901C pin R2_85 and connector X-001C4B pin 12, wire 151 white. Locate the faulty wiring. Repair the faulty wiring..
 - B. If the circuit wiring test passes, the UCM1 has failed internally. Load the appropriate module software.If the fault re-occurs, replace the module.
4. Visually inspect the relevant harnesses and connectors for damage, bent or dislocated pins, corroded terminals, or broken wires. Verify that the connectors are fully installed. Flex the harnesses involved to reveal intermittent breaks or shorts in the wiring concerned. Operate the machine while you monitor the display.
- A. If you find damage or the display indicates other than normal display readings, then repair the damage discovered during the inspection or locate and repair the other than normal display condition and verify that the error has been resolved.
 - B. If you do not find damage and the display indicates only normal readings, then erase the fault code and continue operation.

E0120-03- Feeder ETR Clutch Valve - Shorted to high source

Control Module : UCM1

NOTE: For information concerning this fault, refer to sheet 33.

Context:

The Universal Control Module 1 (UCM1) monitors the operation of the feeder ETR clutch valve Y-448.

Cause:

UCM1 is sensing a short to high source in the feeder ETR clutch valve signal circuit.

Possible failure modes:

1. Faulty solenoid.
2. Faulty electrical wiring shorted to voltage source.
3. Faulty module.

Solution:

1. Verify that the fault is present and active.

Use the display monitor diagnostic capability to view parameter status to check the voltage level.

For additional information about the monitor diagnostic capability, see **Electrical system - Dynamic description Theory of operation – Display monitor diagnostic screens (55.000)**.

A. If the voltage reading is high, continue to Step 2.

B. If there is voltage, the fault may intermittent and not currently active. Continue to Step 6.

2. Verify that the solenoid functions properly.

Disconnect the solenoid from the Gearbox Valves (GV) harness at connector X-448.

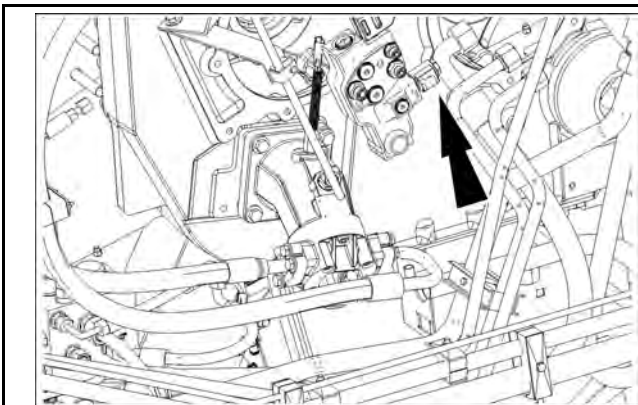

Connector X-448 is located on the left side of the machine.

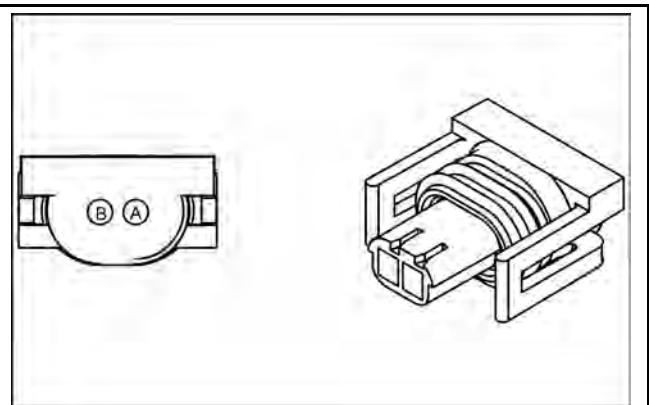

Connector X-448.

Check the display monitor for other fault codes.

- A. If fault code **E0120-03 - Feeder ETR Clutch Valve - Shorted to high source** is still present, continue to Step 3.
- B. If fault code **E0120-05 - Feeder ETR Clutch Valve - Line disconnected** is present, the circuit wiring functions properly. However, the solenoid has failed internally. Replace the solenoid.
3. Check for a short to high condition.

E0127-04- Header Tilt CW Valve - Shorted to low source

Control Module : UCM1

NOTE: For information concerning this fault, refer to sheet 31.

Context:

The Universal Control Module 1 (UCM1) monitors the operation of the header tilt CW valve Y-439.

Cause:

UCM1 is sensing a short to low condition in the header tilt CW valve signal circuit.

Possible failure modes:

1. Faulty solenoid.
2. Faulty electrical wiring shorted to ground.
3. Faulty module.

Solution:

1. Verify that the fault is present and active.

Use the display monitor diagnostic capability to view parameter status to check the voltage level.

For additional information about the monitor diagnostic capability, see **Electrical system - Dynamic description Theory of operation – Display monitor diagnostic screens (55.000)**.

A. If the voltage reading is low, continue to Step 2.

B. If there is voltage, the fault may intermittent and not currently active. Continue to Step 5.

2. Verify that the solenoid functions properly.

Disconnect the solenoid from the Short Feeder Valves (FV) harness at connector X-439.

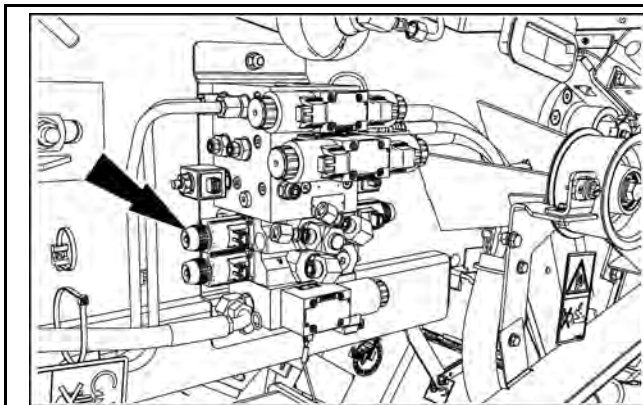

Connector X-439 is located on the left side of the feeder, on the valve block.

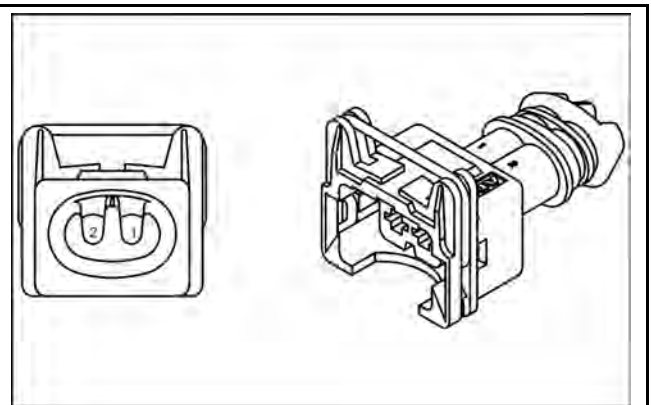

Connector X-439.

Check the display monitor for other fault codes.

A. If fault code **E0127-04 - Header Tilt CW Valve - Shorted to low source** is still present, continue to Step 3.

B. If fault code **E0127-05 - Header Tilt CW Valve - Line disconnected** is present, the circuit wiring functions properly. However, the solenoid has failed internally. Replace the solenoid.

3. Check for an open condition.

Place the key switch in the OFF position.

- B. If you do not find damage and the display indicates only normal readings, then erase the fault code and continue operation.

B. If fault code **E0143-05 - Dust-Off Valve - Line disconnected** is present, the circuit wiring functions properly. However, the solenoid has failed internally. Replace the solenoid.

3. Check for a short to high condition.

Place the key switch in the ON position.

Use a multimeter to check for voltage:

From	To	Result
Dust Off (DO) harness side of connector X-418 pin 2	Chassis ground	Should be approx. 12.0 V

A. If the voltage reading is greater than **12.0 V**, continue to Step 5.

B. If there is approx. **12.0 V**, continue to Step 4.

4. Check for an open condition.

Place the key switch in the OFF position.

Use a multimeter to check for continuity:

From	To	Result
Dust Off (DO) harness side of connector X-418 pin 1	Chassis ground	Should be continuity

A. If there is continuity, continue to Step 5.

B. If there is no continuity, there is an open condition between connector X-418 pin 1 and ground GND-001, wire 1136 black. Locate the open conductor. Repair the open conductor.

5. Check for a short to high condition.

Disconnect the Cab Main (CM) harness from the UCM at connector X-001C3B.

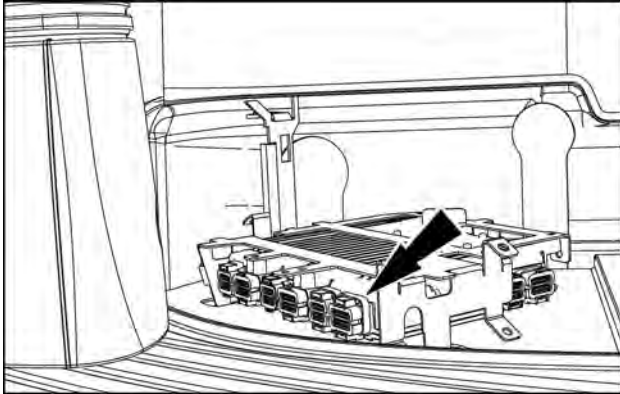
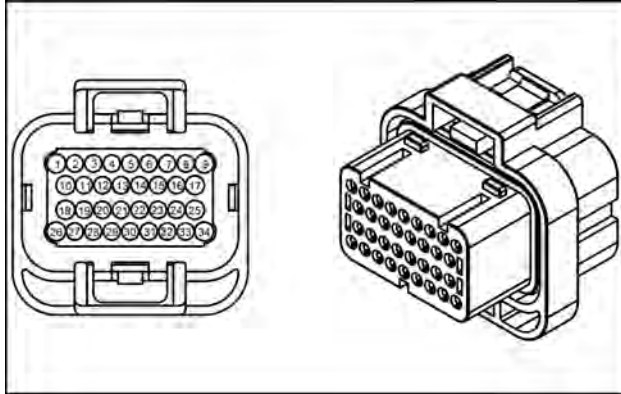
 <p style="text-align: center;">NHIL13AF00020AA 3</p>	 <p style="text-align: center;">84130760 4</p>
<p>Connector X-001C3B is located under the right hand console.</p>	<p>Connector X-001C3B.</p>

Use a multimeter to check for voltage:

From	To	Result
UCM connector X-001C3B pin 17	Chassis ground	Should be approx. 12.0 V

A. If the voltage reading is greater than **12.0 V**, the UCM has failed internally. Load the appropriate module software. If the fault re-occurs, replace the module.

B. If there is approx. **12.0 V**, there is a short to high condition between connector X-001C3B pin 17 and connector X-418 pin 2, wire 1128 white. Locate the shorted conductor. Repair the shorted conductor.

Place the key switch in the OFF position.

Disconnect the Cab Main (CM) harness from UCM at connector X-001C2A.

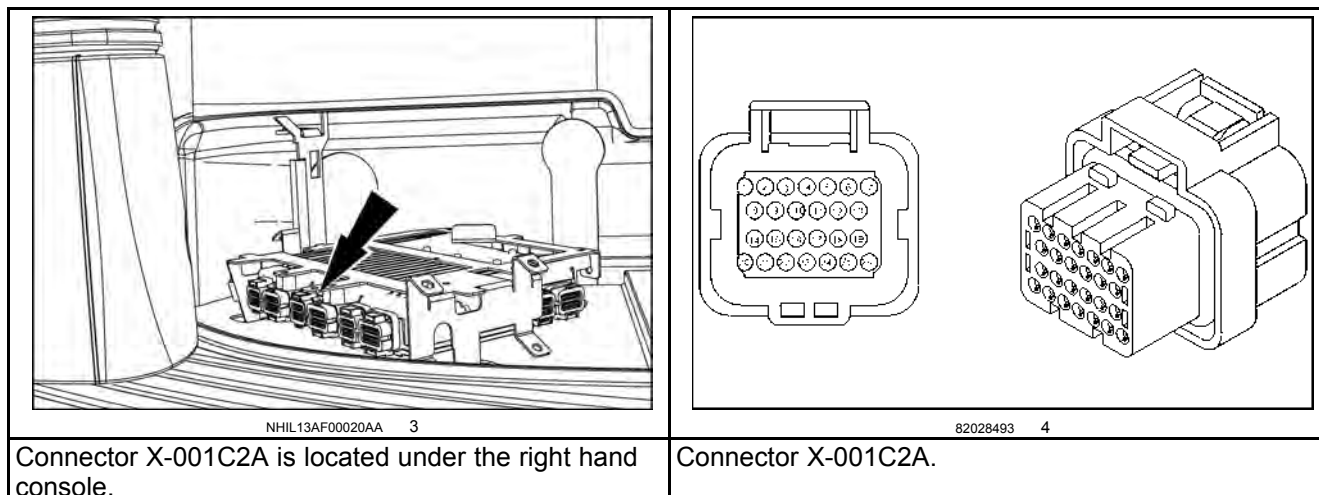

Use a multimeter to check for continuity:

From	To	Result
Cab Main (CM) harness side of connector X-903C pin R2_86	Cab main (CM) harness at connector X-001C2A pin 23	Should be continuity

- A. If the circuit wiring test fails, there is a faulty wire between connector X-903C pin R2_86 and connector X-001C2A pin 23, wire 212 white. Locate the faulty wiring. Repair the faulty wiring..
- B. If the circuit wiring test passes, the UCM1 has failed internally. Load the appropriate module software. If the fault re-occurs, replace the module.
- 4. Visually inspect the relevant harnesses and connectors for damage, bent or dislocated pins, corroded terminals, or broken wires. Verify that the connectors are fully installed. Flex the harnesses involved to reveal intermittent breaks or shorts in the wiring concerned. Operate the machine while you monitor the display.
 - A. If you find damage or the display indicates other than normal display readings, then repair the damage discovered during the inspection or locate and repair the other than normal display condition and verify that the error has been resolved.
 - B. If you do not find damage and the display indicates only normal readings, then erase the fault code and continue operation.

E0160-05-Grid Heater Lamp - Line disconnected

Control Module : UCM1

NOTE: For more information concerning this fault, refer to the electrical schematic on sheet 39.

Context:

The Universal Control Module 1 (UCM1) monitors the operation of the grid heater lamp E-315.

Cause:

UCM1 is sensing an open condition in the grid heater lamp signal circuit.

Possible failure modes:

1. Faulty light.
2. Faulty electrical wiring open condition.
3. Faulty module.

Solution:

1. Verify that the fault is present and active.

Use the display monitor diagnostic capability to view parameter status to check the voltage level.

For additional information about the monitor diagnostic capability, see **Electrical system - Dynamic description Theory of operation – Display monitor diagnostic screens (55.000)**.

A. If there is no voltage, continue to Step 2.

B. If there is voltage, the fault may intermittent and not currently active. Continue to Step 7.

2. Check for an open condition.

Place the key switch in the ON position.

Disconnect the accessory relay K-027 from the Cab Main (CM) harness at connector X-903C.

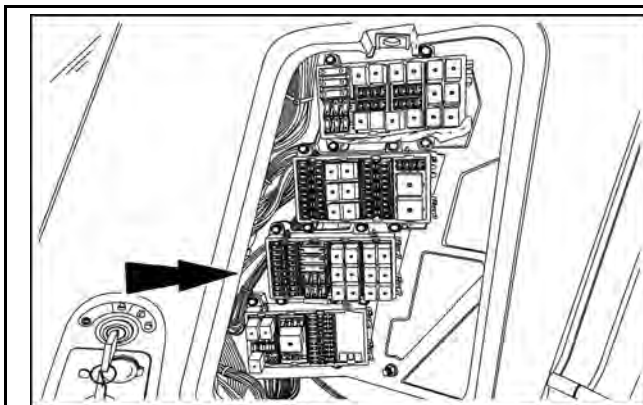

Connector X-903C is located at the bottom of the fuse/relay panel.

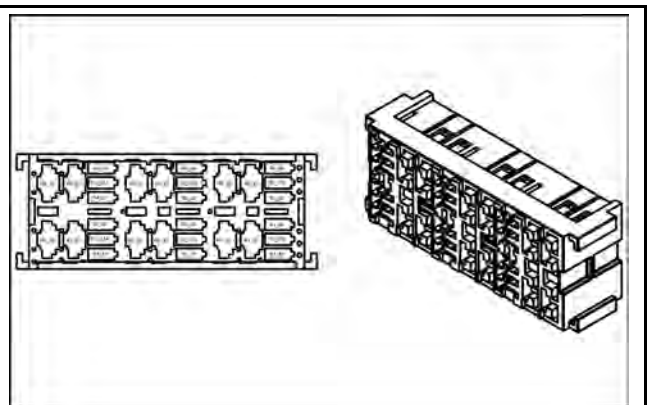

Connector X-903C.

Use a multimeter to check for voltage:

From	To	Result
Cab Main (CM) harness side of connector X-903C pin R5_30	Chassis ground	Should be approx. 12 V

B. If the voltage reading is less than **8.5 V**, there is a short to low condition between connector X-819 pin 5 and connector X-818 pin 6, wire 2112 yellow. Locate the shorted conductor. Repair the shorted conductor.

5. Check for a short to low condition.

Disconnect the Cab Main (CM) harness from UCM at connector X-001C4A.

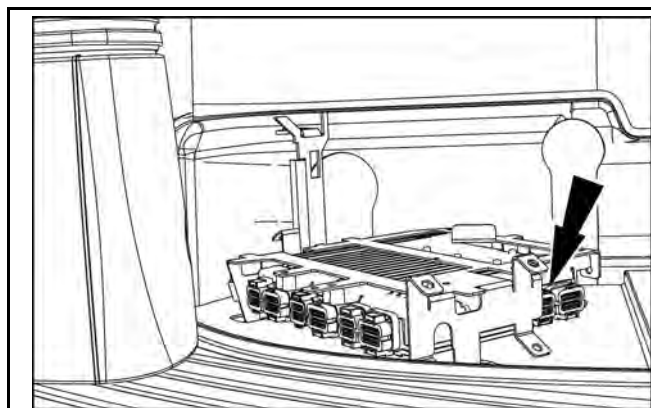

NHIL13AF00020AA 7

Connector X-001C4A is located under the right hand console.

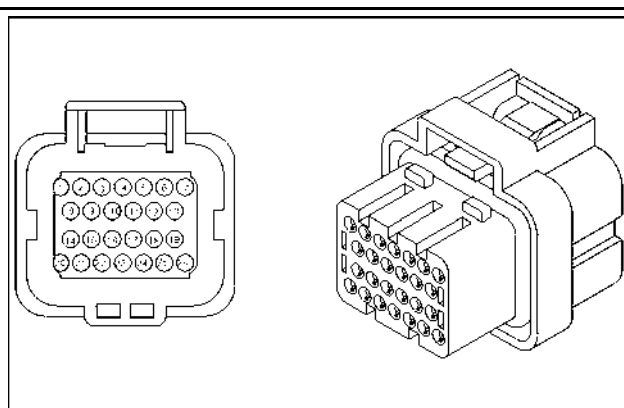

82028493 8

Connector X-001C4A.

Use a multimeter to check for voltage.

From	To	Result
Cab Main (CM) harness side of connector X-001C4A pin 1	Chassis ground	Should be approx. 16.0 V

A. If the voltage reading is correct, the UCM1 has failed internally. Load the appropriate module software. If the fault re-occurs, replace the module.

B. If the voltage reading is less than **8.5 V**, there is a short to low condition between connector X-818 pin 5 and connector X-001C4A pin 1, wire 2112 yellow. Locate the shorted conductor. Repair the shorted conductor.

6. Visually inspect the relevant harnesses and connectors for damage, bent or dislocated pins, corroded terminals, or broken wires. Verify that the connectors are fully installed. Flex the harnesses involved to reveal intermittent breaks or shorts in the wiring concerned. Operate the machine while you monitor the display.

A. If you find damage or the display indicates other than normal display readings, then repair the damage discovered during the inspection or locate and repair the other than normal display condition and verify that the error has been resolved.

B. If you do not find damage and the display indicates only normal readings, then erase the fault code and continue operation.

- A. If there is no voltage at connector X-624, there is an open condition between connector X-543 pin A and connector X-012A pin 9, wire 726 pink. Locate the open conductor. Repair the open conductor.
 - B. If there is no voltage at connector X-622, there is an open condition between connector X-622 pin A and connector X-001C1A pin 9, wire 726 pink. Locate the open conductor. Repair the open conductor.
 - C. If there is no voltage at connector X-623, there is an open condition between connector X-623 pin A and connector X-001C1A pin 9, wire 726 pink. Locate the open conductor. Repair the open conductor.
 - D. If there is voltage at ALL connectors, the UCM1 has failed internally. Load the appropriate module software. If the fault re-occurs, replace the module.
6. Visually inspect the relevant harnesses and connectors for damage, bent or dislocated pins, corroded terminals, or broken wires. Verify that the connectors are fully installed. Flex the harnesses involved to reveal intermittent breaks or shorts in the wiring concerned. Operate the machine while you monitor the display.
- A. If you find damage or the display indicates other than normal display readings, then repair the damage discovered during the inspection or locate and repair the other than normal display condition and verify that the error has been resolved.
 - B. If you do not find damage and the display indicates only normal readings, then erase the fault code and continue operation.

From	To	Result
Blow Off (BOD) harness side of connector X-612 pin A	Chassis ground	Should be approx. 12.0 V
Blow Off (BOD) harness side of connector X-612 pin B	Chassis ground	Should be approx. 2.5 V

A. If the voltage reading is correct, continue to Step 4.

B. If the voltage reading at pin A is incorrect, there is a short to low condition between connector X-612 pin A and the battery, wire 169 or 102 red. Located the shorted conductor. Replace the shorted conductor.

C. If the voltage reading at pin B is incorrect, there is a short to low condition between connector X-612 pin B and connector X-001C4B pin 26, wire 2142 yellow. Located the shorted conductor. Replace the shorted conductor.

4. Check the ground circuit.

Place the ignition key switch in the OFF position.

Use a multimeter to check for continuity:

From	To	Result
Blow Off (BOD) harness side of connector X-612 pin C	Chassis ground	Should be continuity

A. If there is continuity, continue to Step 5.

B. If there is no continuity, there is an open condition between connector X-612 pin C and ground GND-002, wire 659 black. Located the open conductor. Replace the open conductor.

5. Check the LIN power circuit.

Place the ignition key switch in the ON position.

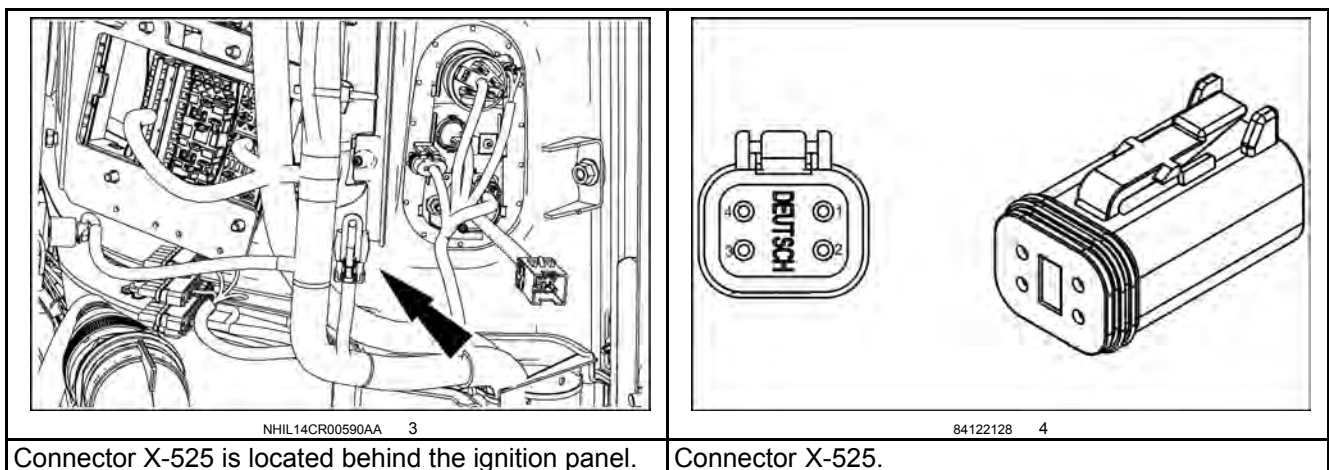

Connector X-525 is located behind the ignition panel.

Connector X-525.

Use a multimeter to check for voltage:

From	To	Result
Connector X-525 pin 1	Chassis ground	Should be approx. 12.0 V

A. If the voltage reading is less than **12.0 V**, there is a short to low condition between connector X-525 pin 1 and the battery, wire 050 red. Located the shorted conductor. Replace the shorted conductor.

B. If there is voltage, continue to Step 6

6. Check the LIN ground circuit.

Place the ignition key switch in the OFF position.

Use a multimeter to check for voltage:

From	To	Result
Connector X-033CN3 pin B7	Chassis ground	Should be approx. 12.0 V

- A. If the voltage reading is low for either one of the three connectors, continue to Step 5.
 - B. If there is voltage, there is a short to low condition between connectors X-033CN3 pin A7, X-033CN3 pin A8, and/or X-033CN3 pin B7 and connector X-624 pin 2, wire 4060 white. Locate the shorted conductor. Repair the shorted conductor.
5. Check the supply circuit for a short to low condition.

Disconnect the Active Spreader Extension (SHO) harness from the H-bridge at connector X-033CN3.

Use a multimeter to check for voltage:

From	To	Result
Connector X-033CN3 pin B1	Chassis ground	Should be approx. 12.0 V
Connector X-033CN3 pin C1	Chassis ground	Should be approx. 12.0 V
Connector X-033CN3 pin C2	Chassis ground	Should be approx. 12.0 V

- A. If the voltage reading is low, there is a short to low condition between connectors X-033CN3 pin B1, X-033CN3 pin C1, and/or X-033CN3 pin C2 and fuse F-201. wire 461 red. Locate the shorted conductor. Repair the shorted conductor.
 - B. If there is voltage, the H-bridge has failed internally. Replace the H-bridge.
6. Check the control circuit for a short to low condition.

Adjust the spreading distribution plate, using spreader switches.

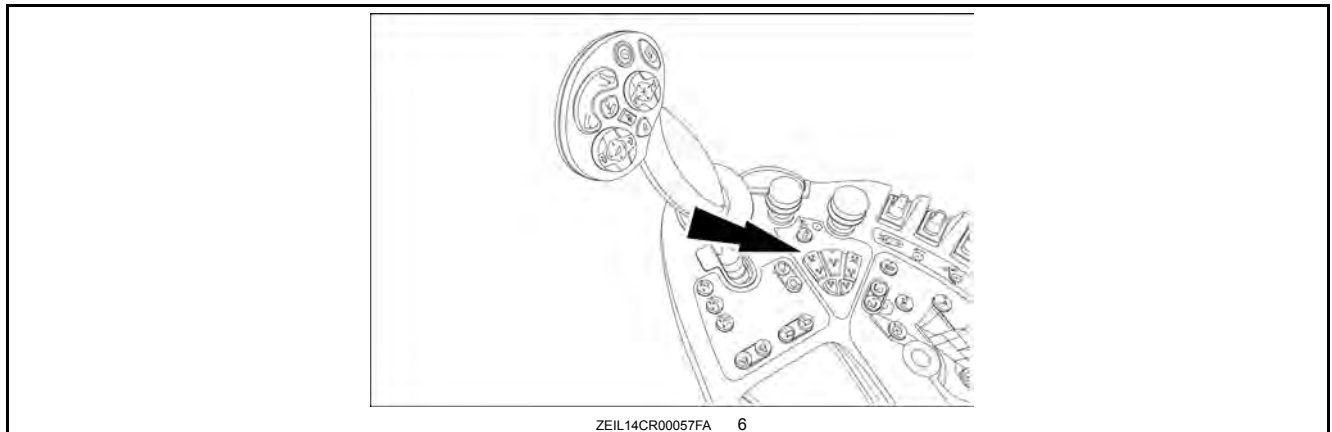

Spreader switches are located on the right hand console.

Use a multimeter to check for voltage:

From	To	Result
Active Spreader (AS) harness side of connector X-624 pin 1	Chassis ground	Should be approx. 12.0 V

- A. If the voltage reading is low, continue to Step 7.
 - B. If there is voltage, the H-bridge has failed internally. Replace the H-bridge.
7. Check the control circuit for a short to low condition.

Disconnect the Active Spreader Extension (SHO) harness from the H-bridge at connector X-033CN3.

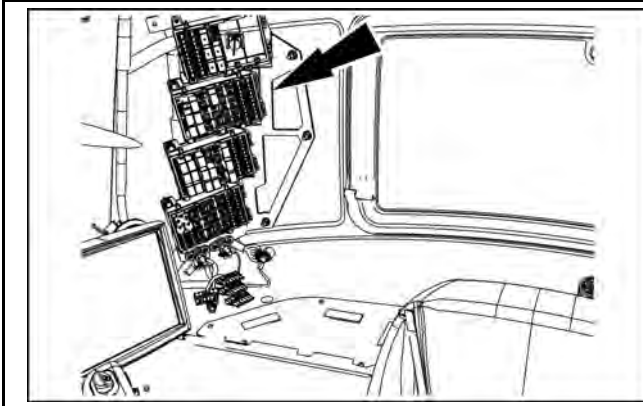

NHIL13AF01444AA 5

Connector X-902C is located inside the fuse/relay panel.

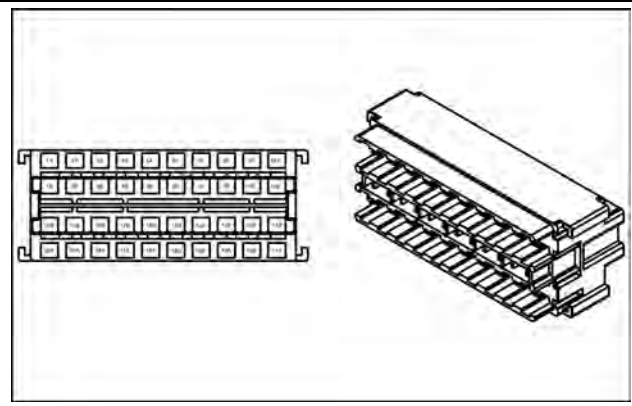

87733581 6

Connector X-902C.

Use a multimeter to check for continuity:

From	To	Result
Cab Main (CM) harness side of connector X-101 pin 2	Cab main (CM) harness at connector X-902C pin 18A	Should be continuity
Cab Main (CM) harness side of connector X-101 pin 1	Cab main (CM) harness at connector X-002C4A pin 17	Should be continuity
Cab Main (CM) harness side of connector X-101 pin 2	Cab Main (CM) harness side of connector X-101 pin 1	Should be no continuity

- A. If the circuit wiring test fails, there is a faulty wire. Locate the faulty wiring. Repair the faulty wiring..
 - B. If the circuit wiring test passes, the UCM1 has failed internally. Load the appropriate module software. If the fault re-occurs, replace the module.
6. Visually inspect the relevant harnesses and connectors for damage, bent or dislocated pins, corroded terminals, or broken wires. Verify that the connectors are fully installed. Flex the harnesses involved to reveal intermittent breaks or shorts in the wiring concerned. Operate the machine while you monitor the display.
- A. If you find damage or the display indicates other than normal display readings, then repair the damage discovered during the inspection or locate and repair the other than normal display condition and verify that the error has been resolved.
 - B. If you do not find damage and the display indicates only normal readings, then erase the fault code and continue operation.

6. Visually inspect the relevant harnesses and connectors for damage, bent or dislocated pins, corroded terminals, or broken wires. Verify that the connectors are fully installed. Flex the harnesses involved to reveal intermittent breaks or shorts in the wiring concerned. Operate the machine while you monitor the display.
 - A. If you find damage or the display indicates other than normal display readings, then repair the damage discovered during the inspection or locate and repair the other than normal display condition and verify that the error has been resolved.
 - B. If you do not find damage and the display indicates only normal readings, then erase the fault code and continue operation.

Place the key switch in the ON position.

Use a multimeter to perform the following:

From	To	Result
Lower Frame Front Slit (LFS) harness side of connector X-635 pin A	Chassis ground	Should be approx. 5.0 V
Lower Frame Front Slit (LFS) harness side of connector X-635 pin C	Chassis ground	Should be approx. 5.2 V

A. If the voltage reading is correct, continue to Step 4.

B. If the voltage reading is incorrect, continue to Step 5.

4. Check the ground reference.

Place the key switch in the OFF position.

Use a multimeter to check for continuity.

From	To	Result
Lower Frame Front Slit (LFS) harness side of connector X-635 pin B	Chassis ground	Should be continuity

A. If there is continuity, continue to Step 5.

B. If there is no continuity, there is an open condition between connector X-635 pin B and connector X-002C4A pin 20, wire 511 blue. Locate the open conductor. Repair the open conductor.

5. Place the key switch in the OFF position.

Disconnect the Cab Main (CM) harness from UCM at connector X-002C3B.

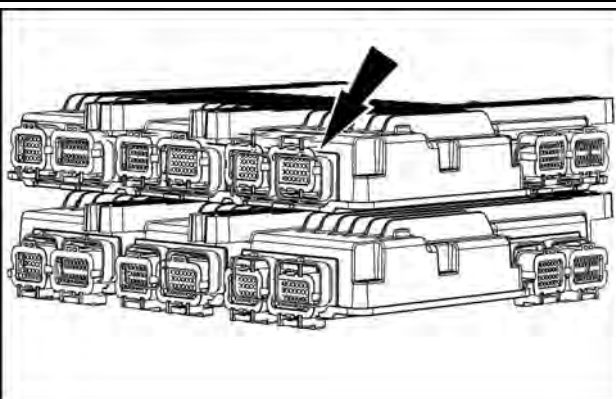
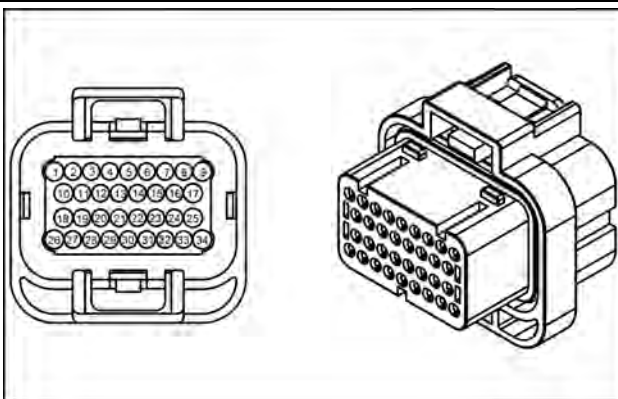
 <p style="text-align: center;">NHIL13AF00378AA 3</p>	 <p style="text-align: center;">84130760 4</p>
<p>Connector X-002C3B is located under the right hand console.</p>	<p>Connector X-002C3B.</p>

Use a multimeter to check for continuity:

From	To	Result
Lower Frame Front Slit (LFS) harness side of connector X-635 pin A	Cab main (CM) harness at connector X-002C1A pin 3	Should be continuity
Lower Frame Front Slit (LFS) harness side of connector X-635 pin C	Cab main (CM) harness at connector X-002C3B pin 12	Should be continuity
Lower Frame Front Slit (LFS) harness side of connector X-635 pin A	Lower Frame Front Slit (LFS) harness side of connector X-635 pin C	Should be no continuity

3. Perform the following circuit wiring test.

Place the key switch in the OFF position.

Disconnect the Cab Main (CM) harness from UCM at connector X-002C4B.

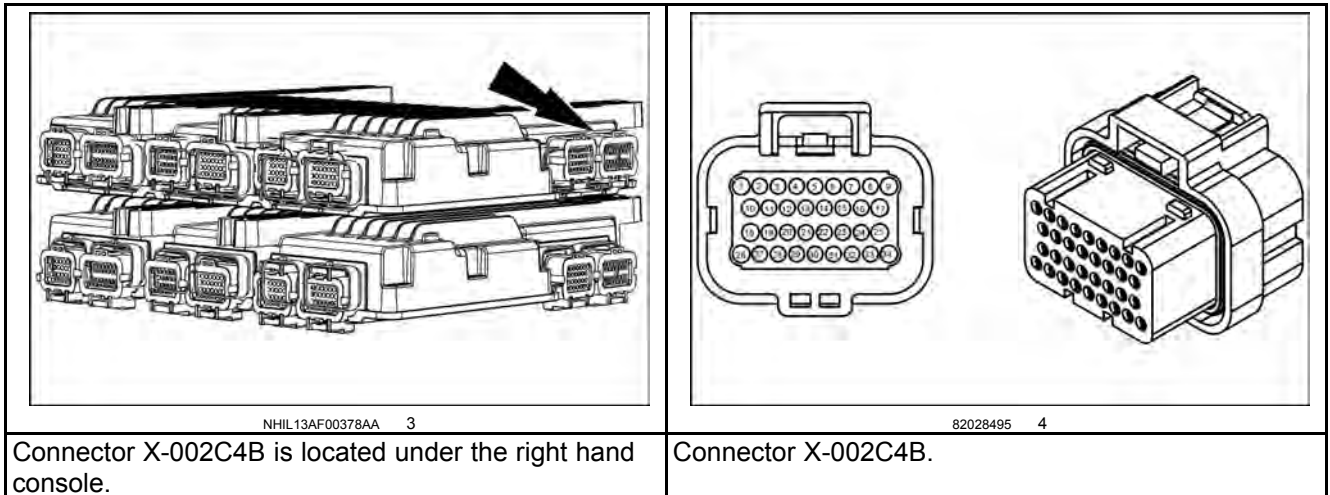

Use a multimeter to check for continuity:

From	To	Result
Lower Frame Front (LF) harness side of connector X-161 pin 1	Cab main (CM) harness at connector X-002C4B pin 7	Should be continuity

- A. If there is continuity, the UCM has failed internally. Load the appropriate module software. If the fault re-occurs, replace the module.
 - B. If there is no continuity, there is a faulty wire between connector X-002C4B pin 7 and connector X-161 pin 1, wire 416 yellow. Locate the faulty wiring. Repair the faulty wiring.
4. Visually inspect the relevant harnesses and connectors for damage, bent or dislocated pins, corroded terminals, or broken wires. Verify that the connectors are fully installed. Flex the harnesses involved to reveal intermittent breaks or shorts in the wiring concerned. Operate the machine while you monitor the display.
- A. If you find damage or the display indicates other than normal display readings, then repair the damage discovered during the inspection or locate and repair the other than normal display condition and verify that the error has been resolved.
 - B. If you do not find damage and the display indicates only normal readings, then erase the fault code and continue operation.

E0351-05-Thresher RPM Sensor - Line disconnected

CR6.80	NA
CR6.90 TIER 4B	NA
CR7.90 TIER 4B	NA
CR8.90 TIER 4B	NA
CR9.90 TIER 4B	NA

Control Module : UCM2

NOTE: For more information concerning this fault, refer to the electrical schematic on sheet 42.

Context:

The Universal Control Module 2 (UCM2) monitors the operation of the rotor RPM sensor B-117.

Cause:

UCM2 is sensing a signal level between **7.8 - 8.2 V** in the rotor RPM sensor signal circuit.

Possible failure modes:

1. Faulty sensor.
2. Faulty electrical wiring open condition.
3. Faulty module.

Solution:

1. Verify that the fault is present and active.

Use the display monitor diagnostic capability to view parameter status to check the voltage level.

For additional information about the monitor diagnostic capability, see **Electrical system - Dynamic description Theory of operation – Display monitor diagnostic screens (55.000)**.

A. If the voltage reading is between **7.8 - 8.2 V**, continue to Step 2.

B. If the voltage reading is the proper range, the fault may intermittent and not currently active. Continue to Step 4.

2. Verify that the sensor functions properly.

Disconnect the sensor from the Left Main Frame (LMF) harness at connector X-117.

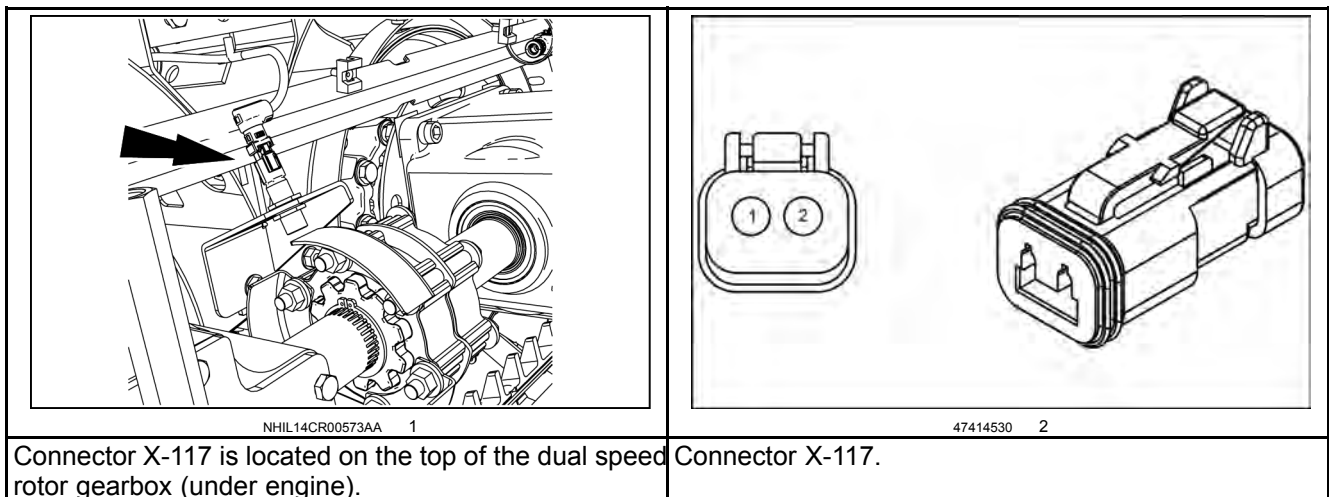

Use a multimeter to check for voltage.

E0370-05- Steering Enable Valve - Line disconnected

Control Module : UCM2

NOTE: For more information concerning this fault, refer to the electrical schematic on sheet 43.

Context:

The Universal Control Module 2 (UCM2) monitors the operation of the steer enable valve Y-470.

Cause:

UCM2 is sensing no voltage in the steer enable valve signal circuit.

Possible failure modes:

1. Faulty solenoid.
2. Faulty electrical wiring open condition.
3. Faulty module.

Solution:

1. Verify that the fault is present and active.

Use the display monitor diagnostic capability to view parameter status to check the voltage level.

For additional information about the monitor diagnostic capability, see **Electrical system - Dynamic description Theory of operation – Display monitor diagnostic screens (55.000)**.

A. If there is no voltage, continue to Step 2.

B. If there is voltage, the fault may intermittent and not currently active. Continue to Step 4.

2. Verify that the solenoid functions properly.

Disconnect the solenoid from the Auto Guidance Valves (AGV) harness at connector X-470.

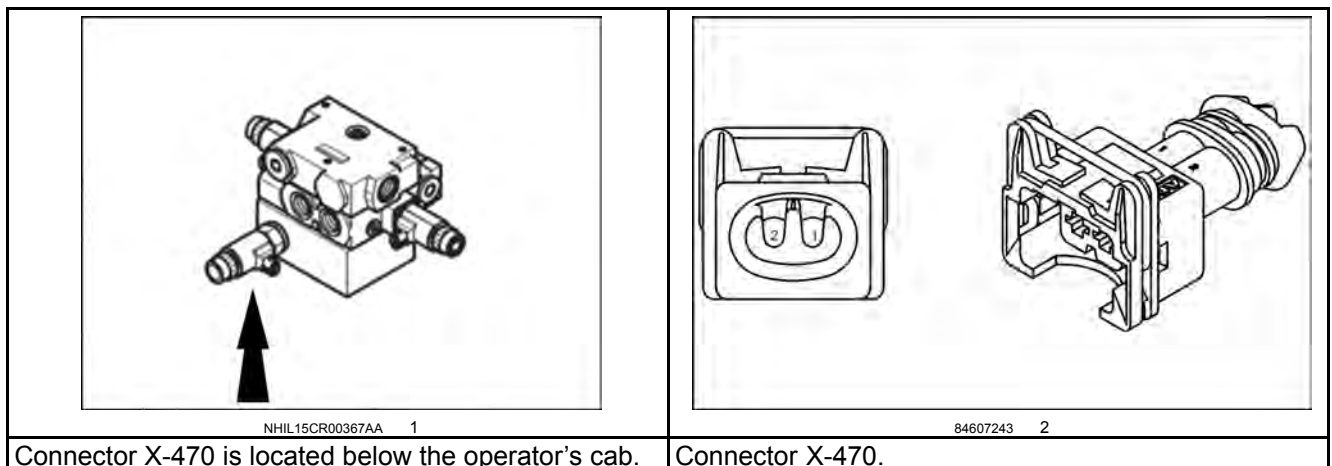

Use a multimeter to check for voltage:

From	To	Result
Auto Guidance Valves (AGV) harness side of connector X-470 pin 1	Chassis ground	Should be approx. 12.0 V

- A. If the voltage reading is approx. **12.0 V**, the solenoid has failed internally. Replace the solenoid.
- B. If the voltage reading is not approx. **12.0 V**, continue to Step 3.

E0383-06-CCO Solenoid - Short circuit

CR6.80	NA
CR6.90 TIER 4B	NA
CR7.90 TIER 4B	NA
CR8.90 TIER 4B	NA
CR9.90 TIER 4B	NA

Control Module : UCM2

NOTE: For more information concerning this fault, refer to the electrical schematic on sheet 41.

Context:

The Universal Control Module 2 (UCM2) monitors the operation of the CCO valve Y-406.

Cause:

UCM2 is sensing a short circuit in the CCO valve signal circuit.

Possible failure modes:

1. Faulty solenoid.
2. Faulty electrical wiring short circuit.
3. Faulty module.

Solution:

1. Verify that the fault is present and active.

For additional information about the monitor diagnostic capability, see **Electrical system - Dynamic description Theory of operation – Display monitor diagnostic screens (55.000)**.

A. If the fault is still present and active, continue to Step 2.

B. If the fault is not present or active, the fault may intermittent and not currently active. Continue to Step 4.

2. Verify that the solenoid functions properly.

Disconnect the solenoid from the Gearbox (GB) harness at connector X-406.

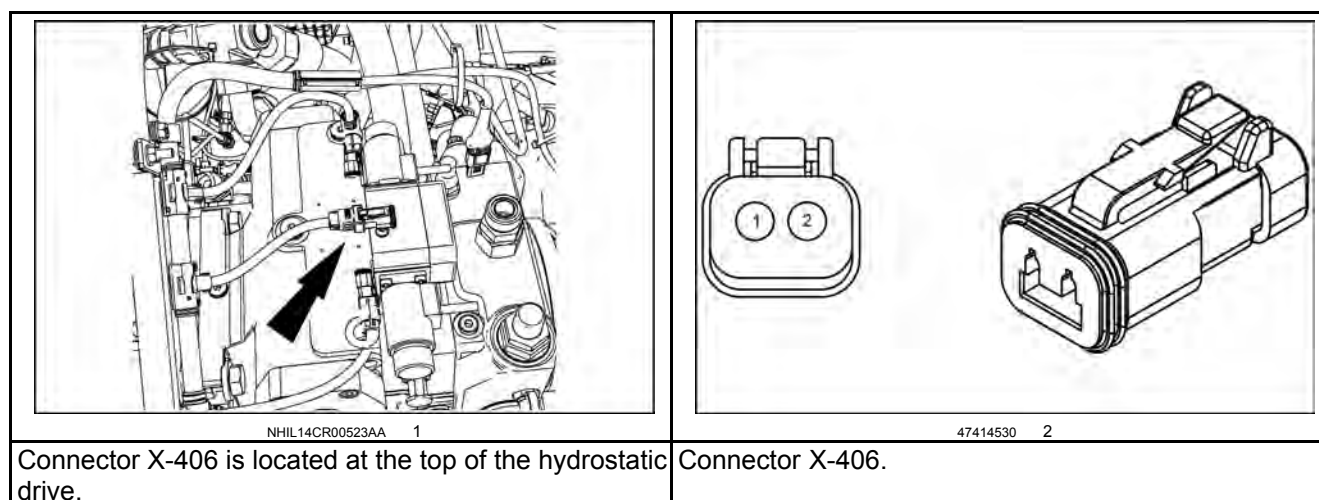

Use a multimeter to check for voltage:

From	To	Result
Gearbox (GB) harness side of connector X-406 pin 1	Chassis ground	Should be approx. 12.0 V

E0393-06-3rd Axle Retract Valve - Short circuit

CR6.80	NA
CR6.90 TIER 4B	NA
CR7.90 TIER 4B	NA
CR8.90 TIER 4B	NA
CR9.90 TIER 4B	NA

Control Module : UCM2

NOTE: For more information concerning this fault, refer to the electrical schematic on sheet 83.

Context:

The Universal Control Module 2 (UCM2) monitors the operation of the 3rd axle fold valve Y-409.

Cause:

UCM2 is sensing a short circuit condition in the 3rd axle fold valve signal circuit.

Possible failure modes:

1. Faulty solenoid.
2. Faulty electrical wiring short circuit.
3. Faulty module.

Solution:

1. Verify that the fault is present and active.

For additional information about the monitor diagnostic capability, see **Electrical system - Dynamic description Theory of operation – Display monitor diagnostic screens (55.000)**.

- A. If the fault is still present and active, continue to Step 2.
 - B. If the fault is not present or active, the fault may intermittent and not currently active. Continue to Step 4.
2. Verify that the solenoid functions properly.

Disconnect the solenoid from the Feeder Axle (AX) harness at connector X-409.

Connector X-409 is located	Connector X-409.
----------------------------	------------------

Use a multimeter to check for voltage:

From	To	Result
Feeder Axle (AX) harness side of connector X-409 pin 1	Chassis ground	Should be approx. 12.0 V

- A. If the voltage reading is approx. **12.0 V**, the solenoid has failed internally. Replace the solenoid.
 - B. If the voltage reading is not approx. **12.0 V**, continue to Step 3.
3. Check for a short circuit condition.

Disconnect the Cab Main (CM) harness from the UCM at connector X-002C3B.

B. If fault code **E0409-05 - Long Distance Light Relay - Line disconnected** is present, the circuit wiring functions properly. However, the relay has failed internally. Replace the relay.

3. Check for a short to high condition.

Place the key switch in the ON position.

Use a multimeter to check for voltage:

From	To	Result
Cab Roof Lower (CRL) harness side of connector X-901D pin R2_86	Chassis ground	Should be approx. 12.0 V

A. If the voltage reading is greater than **12.0 V**, there is a short to high condition between connector X-901D pin R2_86 and connector X-901A pin 3A, wire 2006 red. Locate the shorted conductor. Repair the shorted conductor.

B. If there is approx. **12.0 V**, continue to Step 4.

4. Check for an open condition.

Place the key switch in the OFF position.

Use a multimeter to check for continuity:

From	To	Result
Cab Roof Lower (CRL) harness side of connector X-901D pin R2_85	Chassis ground	Should be continuity

A. If there is continuity, continue to Step 5.

B. If there is no continuity, there is an open condition between connector X-901D pin R2_85 and connector X-002C2B pin 2, wire 2009 gray. Locate the open conductor. Repair the open conductor.

5. Check for a short to high condition.

Reconnect the relay.

Disconnect the Cab Main (CM) harness from the module at connector X-002C2B.

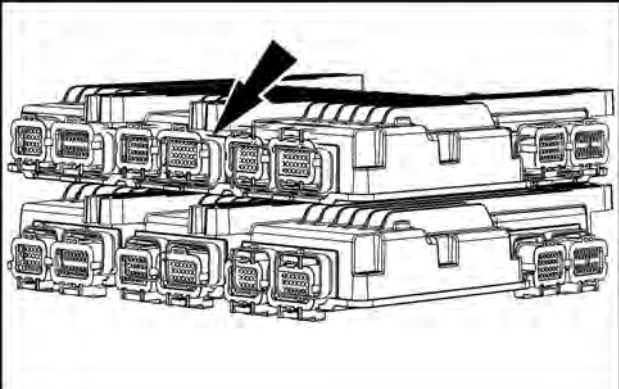
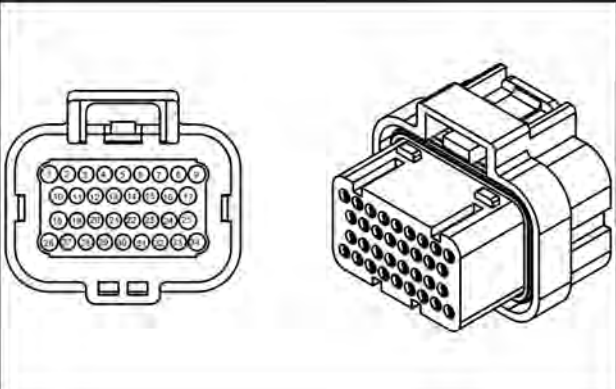
 <p style="text-align: center;">NHIL13AF00378AA 3</p>	 <p style="text-align: center;">82028495 4</p>
<p>Connector X-002C2B is located under the right hand console.</p>	<p>Connector X-002C2B.</p>

Use a multimeter to check for voltage:

From	To	Result
Cab Main (CM) harness side of connector X-002C2B pin 2	Chassis ground	Should be approx. 12.0 V

A. If there is approx. **12.0 V**, the module has failed internally. Load the appropriate module software. If the fault re-occurs, replace the module.

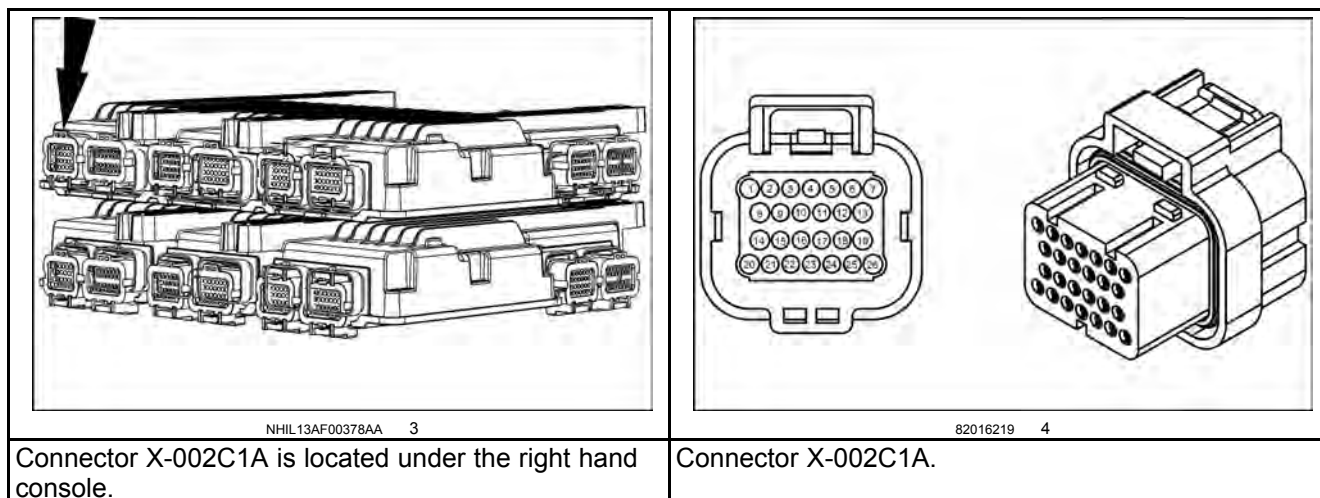

Use a multimeter to check for voltage.

From	To	Result
Cab Main (CM) harness side of connector X-002C1A pin 20	Chassis ground	Should be approx. 16.0 V

- A. If the voltage reading is correct, the relay has failed internally. Replace the relay.
- B. If the voltage reading is greater than **16.0 V**, there is a short to high condition between connector X-903A pin 9A and connector X-002C1A pin 20, wire 050 red. Locate the shorted conductor. Repair the shorted conductor.
- 4. Visually inspect the relevant harnesses and connectors for damage, bent or dislocated pins, corroded terminals, or broken wires. Verify that the connectors are fully installed. Flex the harnesses involved to reveal intermittent breaks or shorts in the wiring concerned. Operate the machine while you monitor the display.
 - A. If you find damage or the display indicates other than normal display readings, then repair the damage discovered during the inspection or locate and repair the other than normal display condition and verify that the error has been resolved.
 - B. If you do not find damage and the display indicates only normal readings, then erase the fault code and continue operation.

From	To	Result
Gearbox (GB) harness side of connector X-403A pin 1	Chassis ground	Should be approx. 12.0 V
Gearbox (GB) harness side of connector X-403B pin 1	Chassis ground	Should be approx. 12.0 V

A. If the voltage reading is approx. **12.0 V**, the solenoid has failed internally. Replace the solenoid.

B. If the voltage reading is not approx. **12.0 V**, continue to Step 3.

3. Perform the following circuit wiring test.

Place the key switch in the OFF position.

Disconnect the Cab Main (CM) harness from UCM at connector X-002C3A.

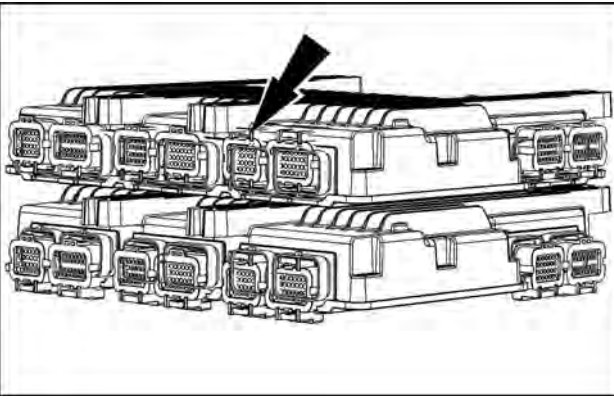
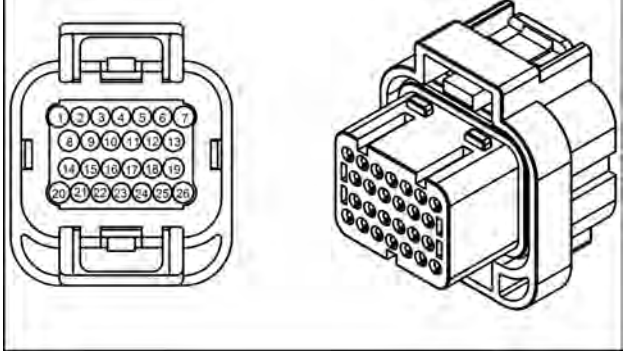
 <p style="text-align: center;">NHIL13AF00378AA 3</p>	 <p style="text-align: center;">84130757 4</p>
<p>Connector X-002C3A is located under the right hand console.</p>	<p>Connector X-002C3A.</p>

Use a multimeter to check for continuity:

From	To	Result
Gearbox (GB) harness side of connector X-403A pin 1	Cab main (CM) harness at connector X-002C3A pin 19	Should be continuity
Gearbox (GB) harness side of connector X-403B pin 1	Cab main (CM) harness at connector X-002C3A pin 6	Should be continuity

A. If there is continuity, the UCM has failed internally. Load the appropriate module software. If the fault re-occurs, replace the module.

B. If there is no continuity, there is a faulty wire between connector X-002C3A pin 19 or X-002C3A pin 6 and connector X-403A pin 1 or X-403B pin 1, wire 879 or 880 white. Locate the faulty wiring. Repair the faulty wiring.

4. Visually inspect the relevant harnesses and connectors for damage, bent or dislocated pins, corroded terminals, or broken wires. Verify that the connectors are fully installed. Flex the harnesses involved to reveal intermittent breaks or shorts in the wiring concerned. Operate the machine while you monitor the display.

A. If you find damage or the display indicates other than normal display readings, then repair the damage discovered during the inspection or locate and repair the other than normal display condition and verify that the error has been resolved.

B. If you do not find damage and the display indicates only normal readings, then erase the fault code and continue operation.

From	To	Result
Lower Frame Front (LF) harness side of connector X-630 pin A	Chassis ground	Should be continuity

A. If there is no continuity, continue to Step 3.

B. If there is continuity, continue to Step 5.

NOTE: Before proceeding to step 3, verify the control direction of X-630 pin A and X-630 pin B and adjust the following as necessary.

3. Check the control circuit for a short circuit condition.

Disconnect the Main Frame Front (FF) harness from the H-bridge at connector X-031CN3.

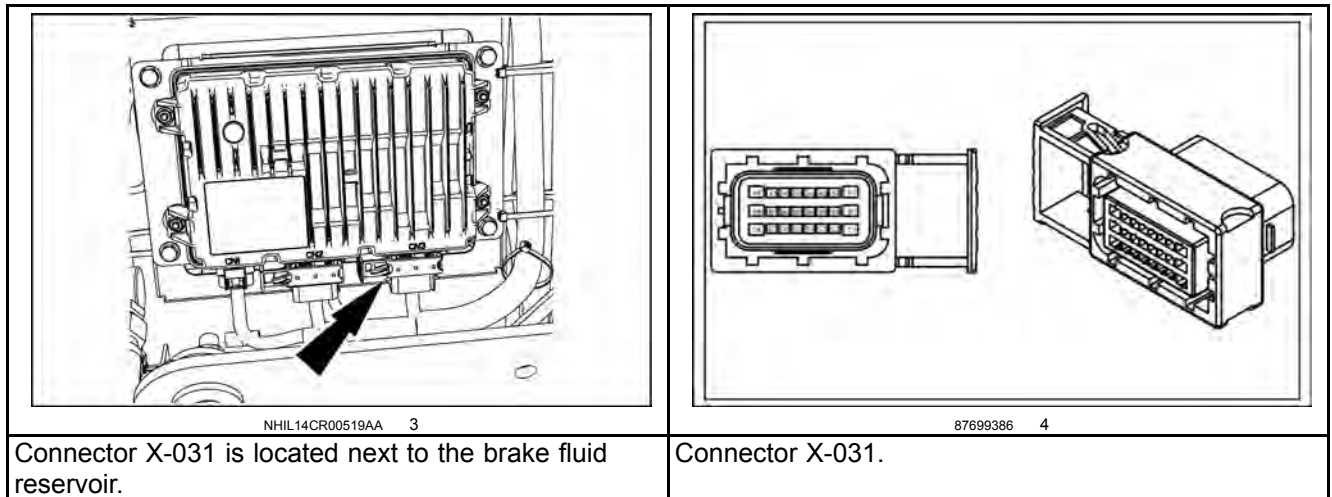

Use a multimeter to check for continuity:

From	To	Result
Connector X-031CN3 pin A7	Chassis ground	Should be continuity
Connector X-031CN3 pin A8	Chassis ground	Should be continuity
Connector X-031CN3 pin B7	Chassis ground	Should be continuity

A. If there is no continuity, continue to Step 4.

B. If there is continuity, there is a short circuit condition between connectors X-031CN3 pin A7, X-031CN3 pin A8, and/or X-031CN3 pin B7 and connector X-630 pin A, wire 716 white. Locate the shorted conductor. Repair the shorted conductor.

4. Check the supply circuit for a short circuit condition.

Disconnect the Main Frame Front (FF) harness from the H-bridge at connector X-031CN3.

Use a multimeter to check for continuity:

From	To	Result
Connector X-031CN3 pin B1	Chassis ground	Should be continuity
Connector X-031CN3 pin C1	Chassis ground	Should be continuity
Connector X-031CN3 pin C2	Chassis ground	Should be continuity

A. If there is no continuity, there is a short circuit condition between connectors X-031CN3 pin B1, X-031CN3 pin C1, and/or X-031CN3 pin C2 and fuse F-093, wire 029 red. Locate the shorted conductor. Repair the shorted conductor.

B. If there is continuity, the H-bridge has failed internally. Replace the H-bridge.

5. Check the control circuit for a short circuit condition.

Use a multimeter to check for continuity:

B. If the voltage reading is less than **3.5 V**, reconnect the switch and continue to Step 3.

3. Check for a faulty wiring.

Use a multimeter to check for voltage:

From	To	Result
Connector X-822 pin 3	Chassis ground	Should be less than 3.5 V

A. If the voltage reading is greater than **3.5 V**, the switch failed internally. Replace.

B. If the voltage reading is less than **3.5 V**, continue to Step 4.

4. Check for a faulty wiring.

Disconnect the Right Console (RC) harness from the ACM at connector X-004H8A

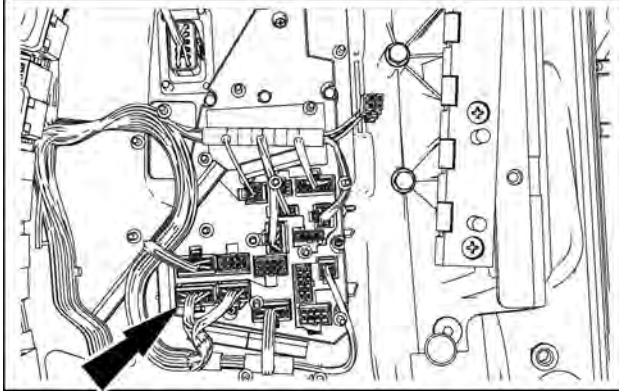
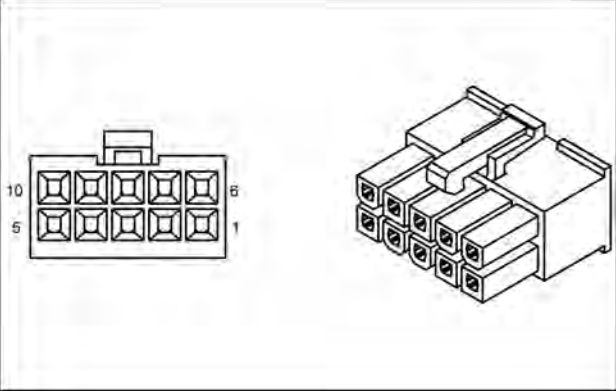
 <p style="text-align: center;">NHIL15CR00271AA 3</p>	 <p style="text-align: center;">87694703 4</p>
<p>Connector X-004H8A is located at the bottom of the ACM.</p>	<p>Connector X-004H8A.</p>

Use a multimeter to check for voltage:

From	To	Result
Right Console (RC) harness side of connector X-004H8A pin 6	Chassis ground	Should be less than 3.5 V

A. If the voltage reading is greater than **3.5 V**, there is a faulty wire between connector X-004H8A pin 6 and connector X-822 pin 3, wire 2221 yellow. Locate the faulty wire. Replace the faulty wire.

B. If the voltage reading is less than **3.5 V**, the ACM has failed internally. Replace the ACM. .

5. Check for a faulty wiring.

Disconnect the Cab Main (CM) harness from the ACM at connector X-004.

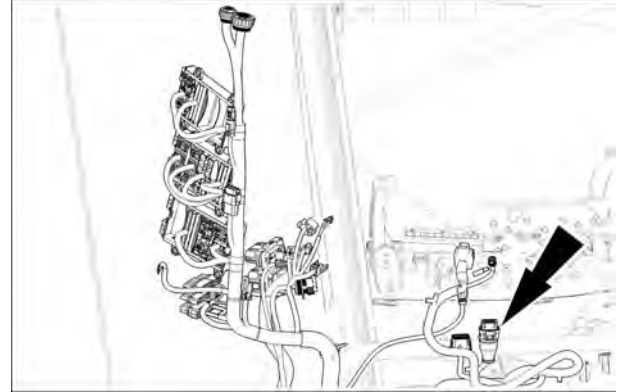
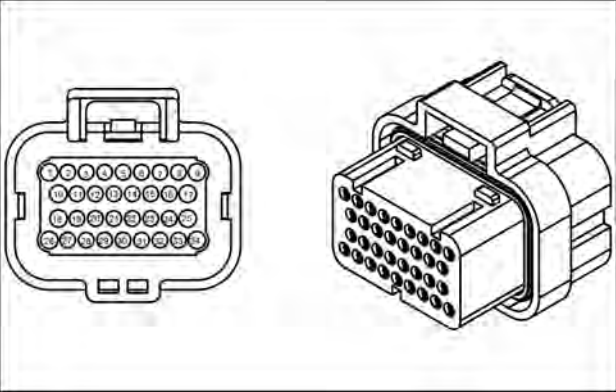
 <p style="text-align: center;">BAPH14CR00031FA 5</p>	 <p style="text-align: center;">87410946 6</p>
<p>Connector X-004 is located under the right hand console.</p>	<p>Connector X-004.</p>

E0832-07-Work Lights Switch - Mechanical out of range

Control Module : LCP

NOTE: For more information concerning this fault, refer to the electrical schematic on sheet 7.

Context:

The Universal Control Module (UCM) monitors the operation of the work lights switch on the Light Control Panel (LCP) A-016.

Cause:

LCP is sensing a mechanical malfunction with the work lights switch circuit.

Possible failure modes:

1. Faulty LCP.
2. Faulty electrical wiring.
3. Faulty module.

Solution:

1. Verify that the fault is present and active.

Use the display monitor diagnostic capability to view parameter status to check the voltage level.

For additional information about the monitor diagnostic capability, see **Electrical system - Dynamic description Theory of operation – Display monitor diagnostic screens (55.000)**.

A. If the voltage reading is high, continue to Step 2.

B. If there is voltage, the fault may intermittent and not currently active. Continue to Step 6.

2. Place the ignition key in the ON position.

Check the supply circuit.

Disconnect the Cab Roof Lower (CRL) harness from the LCP at connector X-016.

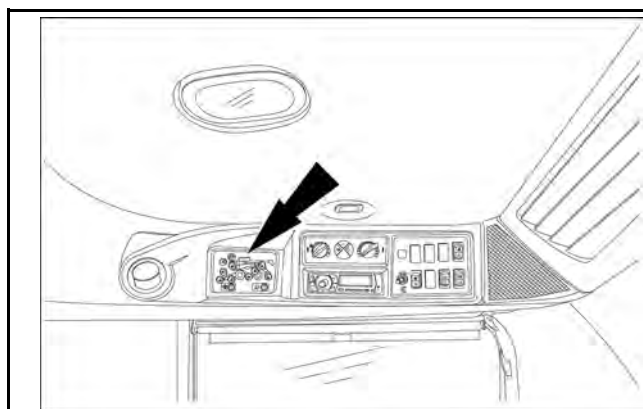

Connector X-016 is located on the overhead console.

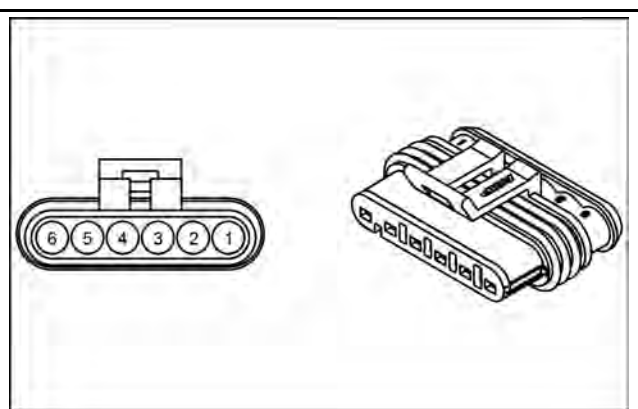

Connector X-016.

Use a multimeter to check for voltage:

From	To	Result
Cab Roof Lower (CRL) harness side of connector X-016 pin 1	Chassis ground	Should be approx. 12 V

- A. If the voltage reading is high, continue to Step 3.

- A. If you find damage or the display indicates other than normal display readings, then repair the damage discovered during the inspection or locate and repair the other than normal display condition and verify that the error has been resolved.
- B. If you do not find damage and the display indicates only normal readings, then erase the fault code and continue operation.

E1149-03-Track Right, Front, Up Valve - Shorted to high source

Control Module : UCM3

NOTE: For more information concerning this fault, refer to the electrical schematic on sheet 86.

Context:

The Universal Control Module 3 (UCM3) monitors the operation of the right front up valve Y-480.

Cause:

UCM3 is sensing a short to high condition in the right front up valve signal circuit.

Possible failure modes:

1. Faulty solenoid.
2. Faulty electrical wiring shorted to voltage source.
3. Faulty module.

Solution:

1. Verify that the fault is present and active.

Use the display monitor diagnostic capability to view parameter status to check the voltage level.

For additional information about the monitor diagnostic capability, see **Electrical system - Dynamic description Theory of operation – Display monitor diagnostic screens (55.000)**.

A. If the voltage reading is high, continue to Step 2.

B. If there is voltage, the fault may intermittent and not currently active. Continue to Step 6.

2. Verify that the solenoid functions properly.

Disconnect the solenoid from the Suspended Tracks (STE) harness at connector X-480B.

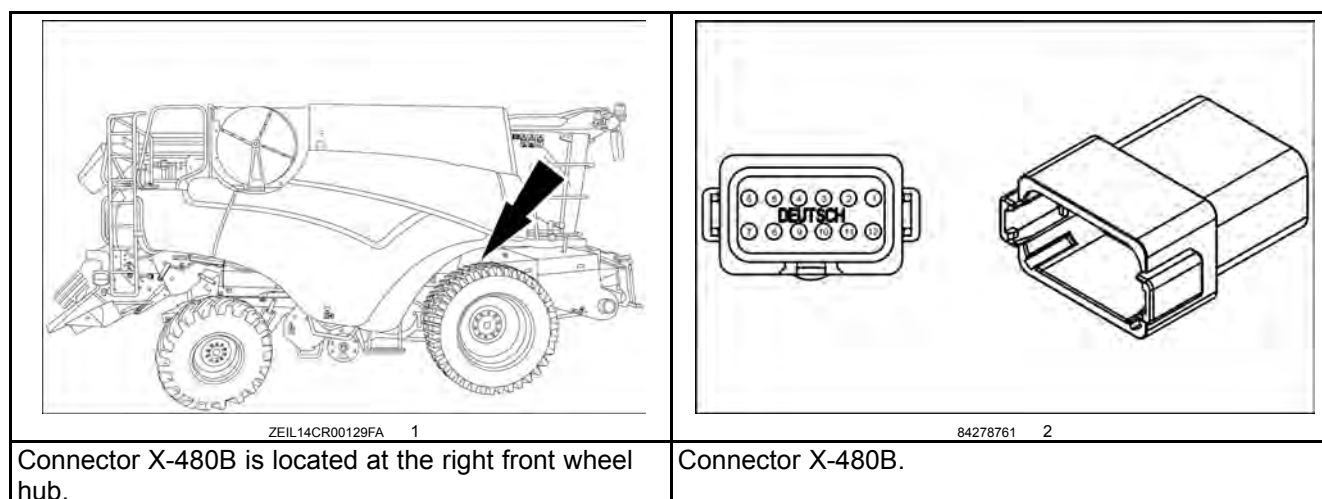

Check the display monitor for other fault codes.

- A. If fault code **E1149-03 - Track Right, Front, Up Valve - Shorted to high source** is still present, continue to Step 3.
- B. If fault code **E1149-05 - Track Right, Front, Up Valve - Line disconnected** is present, the circuit wiring functions properly. However, the solenoid has failed internally. Replace the solenoid.
3. Check for a short to high condition.

Disconnect the Cab Main (CM) harness from UCM at connector X-003C4B.

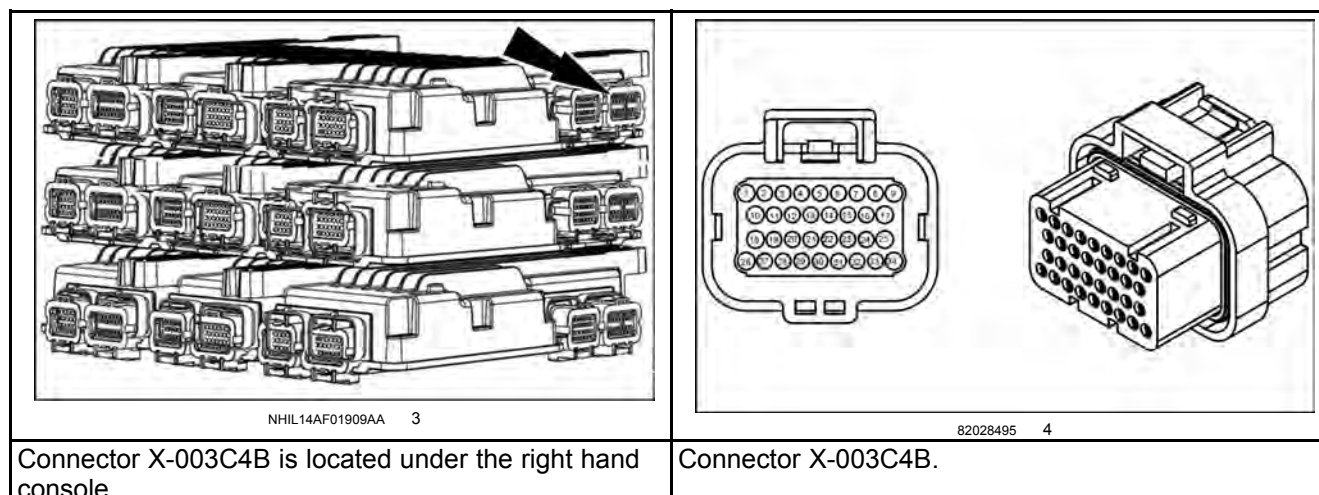

Use a multimeter to check for voltage.

From	To	Result
Cab Main (CM) harness side of connector X-003C4B pin 2	Chassis ground	Should be approx. 16.0 V

- A. If the voltage reading is correct, the relay has failed internally. Replace the relay.
 - B. If the voltage reading is greater than **16.0 V**, there is a short to high condition between connector X-904A pin R4_87 and connector X-003C4B pin 2, wire 307 red. Locate the shorted conductor. Repair the shorted conductor.
4. Visually inspect the relevant harnesses and connectors for damage, bent or dislocated pins, corroded terminals, or broken wires. Verify that the connectors are fully installed. Flex the harnesses involved to reveal intermittent breaks or shorts in the wiring concerned. Operate the machine while you monitor the display.
- A. If you find damage or the display indicates other than normal display readings, then repair the damage discovered during the inspection or locate and repair the other than normal display condition and verify that the error has been resolved.
 - B. If you do not find damage and the display indicates only normal readings, then erase the fault code and continue operation.



Product feeding - 60

Floating roll, feed chain, and drive - 105

**CR6.80 TIER 4B
CR6.90 TIER 4B
CR7.90 TIER 4B
CR8.90 TIER 4B
CR9.90 TIER 4B**

13. Outer sprockets **(1)** should be within **1 - 2 mm (0.04 - 0.08 in)** clearance **(A)** with anti-wrap tab **(2)** on each side.
14. There should be clearance **(B)** between the two spacers **(3)** and **(4)** inside the bearing housing to avoid overloading the bearing.

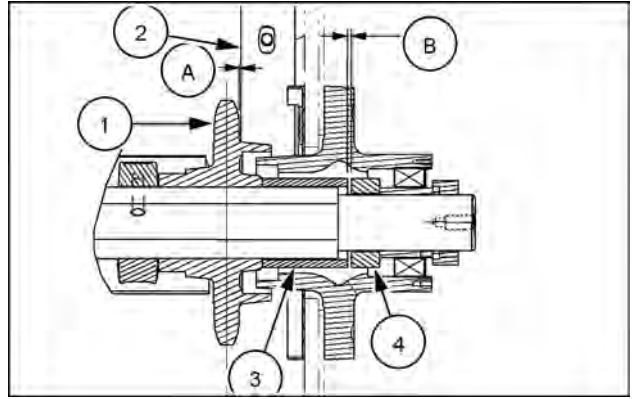

20100403 12

15. To match the apron chain, correct center to center sprocket spacing **(C)** is important. For wide feeders, it should be **1311 mm (51.63 in)** from one outer sprocket to the other. For narrow feeders, it should be **872 mm (34.31 in)** from one outer sprocket to the other. The center sprocket needs to be half way between the outer sprockets.

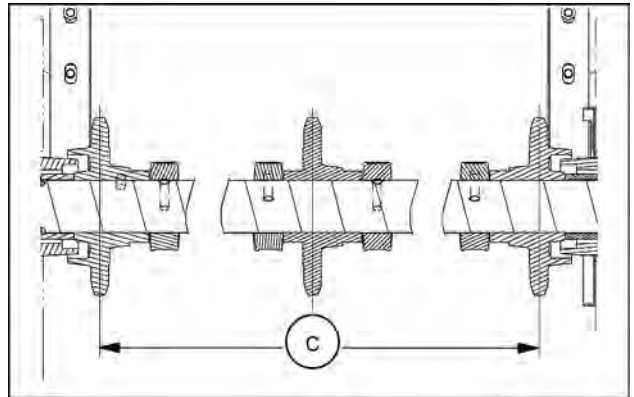

20100406 13

16. Once the sprockets have been correctly positioned, tighten the M10 x 30 socket-head screws with helical lock washers **(1)** on each sprocket's retaining clamp **(2)**.

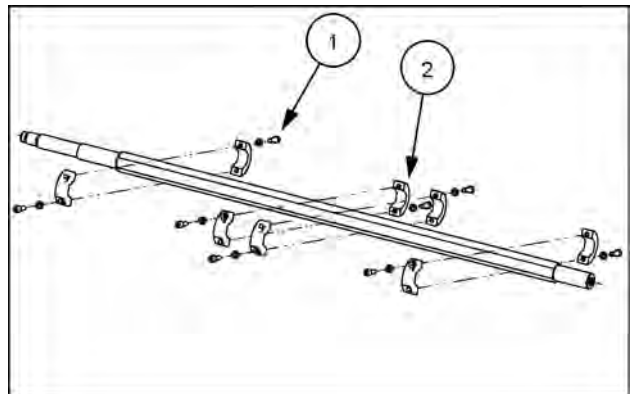

20100397 14

17. Install the two sets of anti-wrap shields **(1)** (one shown, left side). Each shield set is in two pieces, front and back. Each set is held in place by six M8 x 20 hex socket cap screws **(2)**, three on top and three on bottom. Apply **LOCTITE® 242** thread lock compound to the threads of the screws and tighten.

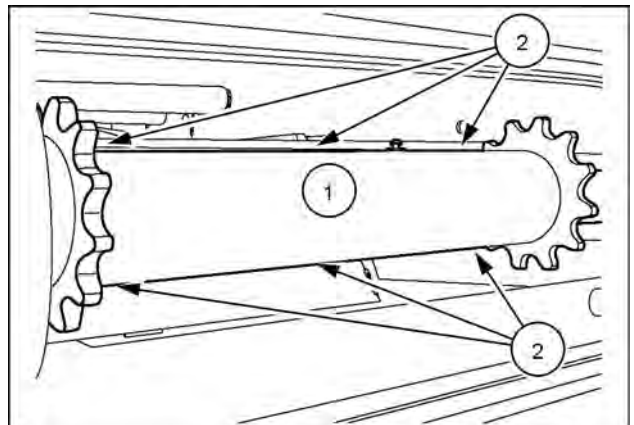

83090855 15

Threshing - Overview - Rotor and Rotor Chamber

CR6.80	NA
CR6.90	NA
CR7.90	NA
CR8.90	NA
CR9.90	NA

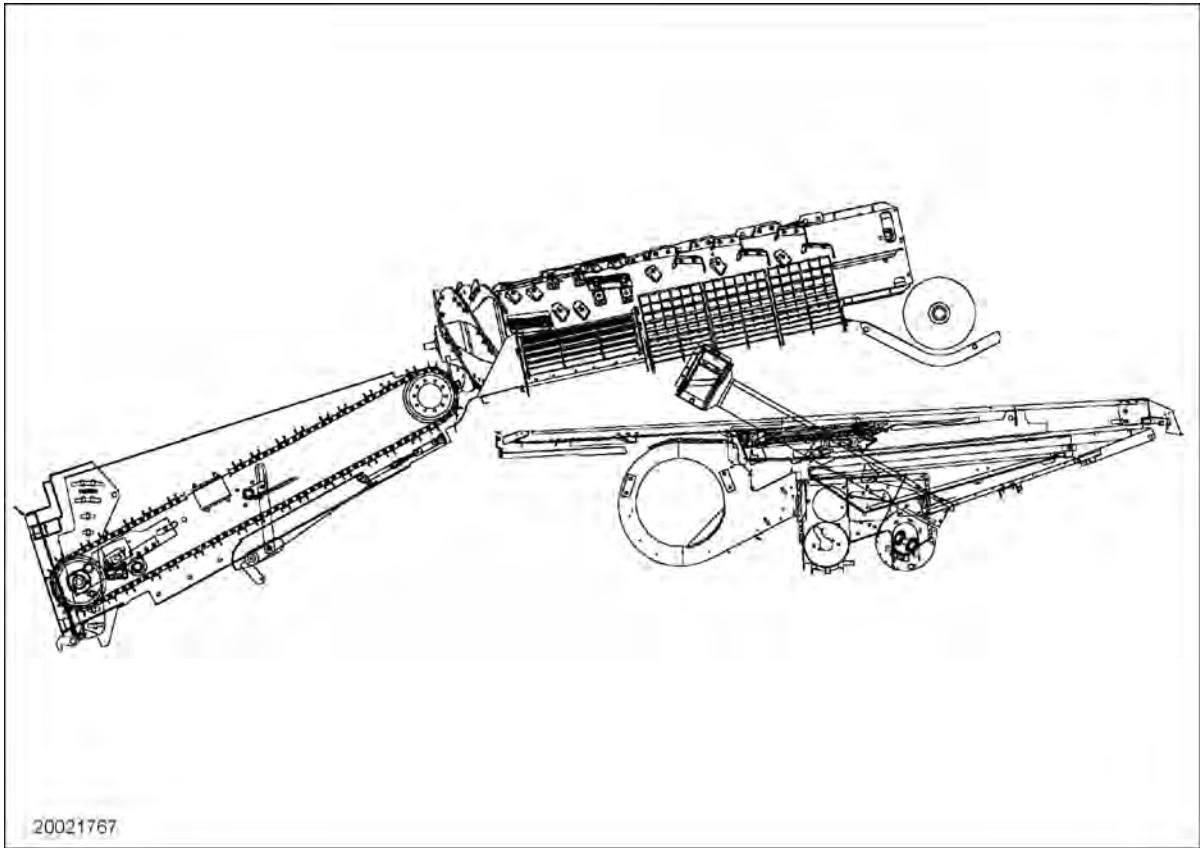

20021767 1

The NEW HOLLAND CR combines are equipped with two different size rotors. The CR6.80, CR6.90 and the CR7.90 are equipped with two **432 mm (17 in)** diameter rotors, while the CR8.90, CR 9.90, and the CR10.90 are equipped with two **559 mm (22 in)** diameter rotors. The rotors are driven by the rotor gearboxes, covered in **Rotor gearbox housing - Static description (66.331)**.

Both sizes of rotors incorporate augers at the front of the rotor to transport crop material to the threshing area. Replaceable rasp bars are at the front portion of each rotor, behind the auger. Rasp bars thresh the crop against the concaves. Replaceable transport blades are at the rear portion of the rotor to force the crop material against the separator grates. Rotors may also have “fingers” installed at the rear portion of the rotor. These fingers are helpful in separating grain in long, wet straw conditions such as a rice crop.

The rotors are designed to rub the crop against the concave rub bars and concave wires. The movement of crop rearward is controlled so the crop passes between the rotor and concaves several times. This allows for more efficient and complete threshing to reduce the risk of crop loss.

Any remaining grain and crop residue is transported to the rear half of the rotor where the rotor transport blades and separator grates separate the remaining grain from the crop residue by centrifugal force.

Grain drops through the concaves and separator grates onto the grain pan where the grain is cleaned. Any material remaining in the rotor chamber is conveyed out the back of the rotor and to the discharge beater.

The rotor speed, vane pitch and concave clearance-distance between the rotors and concave are adjustable and should be altered according to crop and conditions. Improper rotor speed and/or concave clearance can result in poor threshing performance. If either rotor speed or concave clearance is incorrect, under-threshing, over-threshing and/or grain damage could occur.

Contents

Threshing - 66

Drum/Rotor variator with electrical control - 321

FUNCTIONAL DATA

Drum/Rotor variator with electrical control	
Dynamic description - Control Valve (*)	3
Exploded view (*)	6
Variator driven disks	
Static description (*)	11
Bridge	
Exploded view (*)	12
Exploded view (*)	13

SERVICE

Variator drive disks	
Remove (*)	14
Inspect Drive Sheave (*)	16
Install (*)	17
Variator driven disks	
Remove Driven sheave (*)	19
Disassemble (*)	21
Inspect (*)	23
Assemble (*)	24
Install (*)	26
Variator belt	
Replace (*)	28
Bridge	
Disassemble (*)	30
Assemble (*)	35

(*) See content for specific models

Rotor gearbox housing Right-hand - Remove

CR6.80	NA
CR6.90	NA
CR7.90	NA
CR8.90	NA
CR9.90	NA

Prior operation:

Variator driven disks - Remove Driven sheave (66.321) .

1. Turn the combine ignition switch to the "ON" position. Use the switch on the right console to close the upper sieve, then turn the ignition switch to the "OFF" position. Remove the grain tank access panel and the straw hood access panel **(1)** from the combine. This allows access to the rotor gearbox. Place a suitable piece of plywood on upper sieve to prevent any damage.

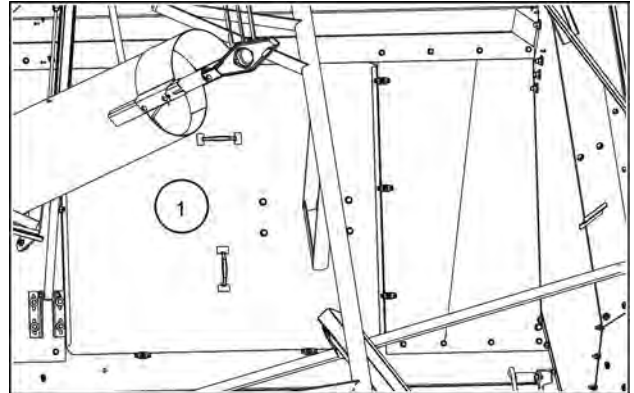

NHIL14CR00457AA 1

2. Disconnect the right rotor gearbox from the left by removing the six bolts from the gearbox coupler **(1)**.

NOTE: The rotor gearbox coupler can be accessed through the grain tank access panel or through the straw hood access panel.

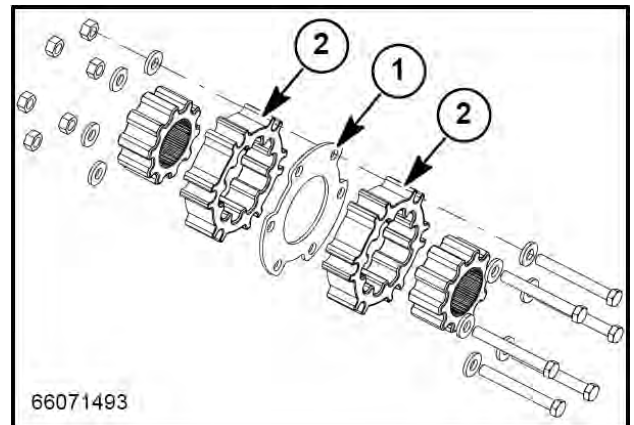

66071493

66071493 2

3. Remove the top rotor cover for the right rotor. Wrap a chain or lifting strap **(1)** around the rotor. Support the rear of the rotor by hooking the chain or tying the strap off to framework above the rotor.

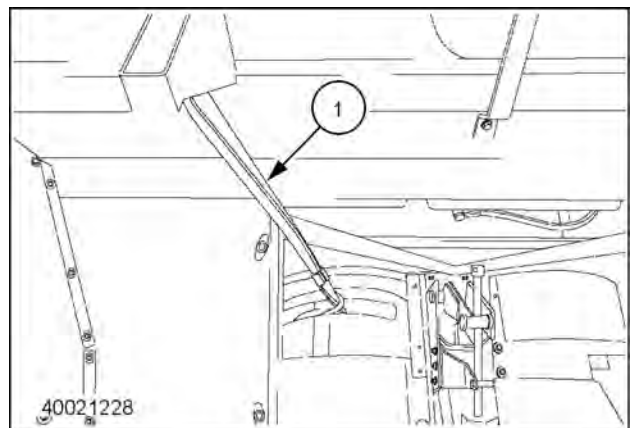

40021228

40021228 3



PRINTED IN U.S.A.

© 2015 CNH Industrial America LLC.

All rights reserved. No part of the text or illustrations of this publication may be reproduced.

NEW HOLLAND policy is one of continuous improvement and the right to change prices, specification or equipment at any time without notices is reserved.

All data given in this publication is subject to production variations. Dimensions and weight are approximate only and the illustrations do not necessarily show products in standard condition. For exact information about any particular product, please consult your NEW HOLLAND Dealer.

Beater - Install Pins and blades

CR6.80	NA
CR6.90	NA
CR7.90	NA
CR8.90	NA
CR9.90	NA

⚠ WARNING

Avoid injury!

1. Disengage all drives.
 2. Engage parking brake.
 3. Lower all attachments to the ground, or raise and engage all safety locks.
 4. Shut off engine.
 5. Remove key from key switch.
 6. Wait for all machine movement to stop.
- Failure to comply could result in death or serious injury.

W1197A

NOTE: Pay attention, install the beater blade (2) in the right direction.

- The arrow (A) indicates the direction of rotation of the beater.
- The arrow (B) indicates the direction of drive of the machine.

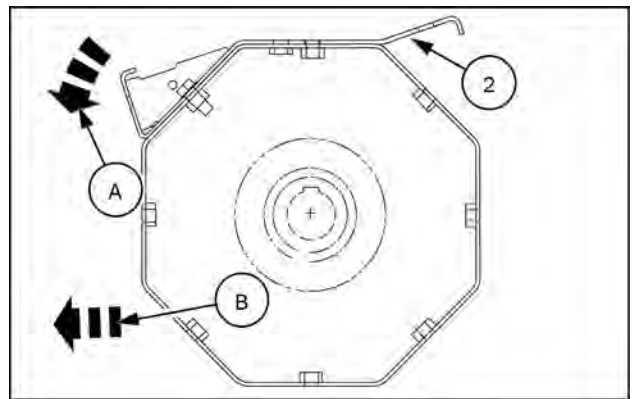

ZEIL14CXF0038AA 1

1. Install the beater blade (2) on the entire length of the beater assembly with the bolts (3) and the lock washers (4).

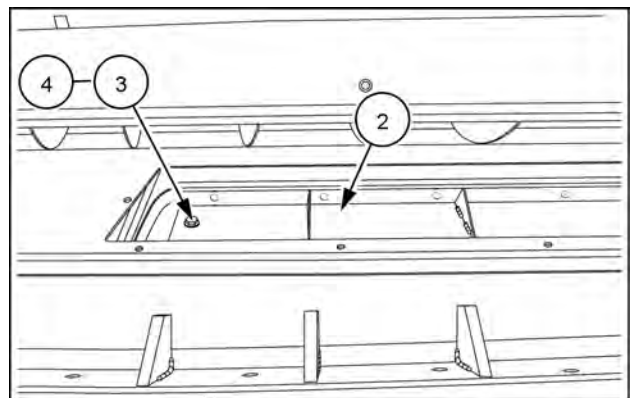

ZEIL14CXF0031AZ 2

2. Rotate (A) the beater so the next beater blade (2) can be installed.

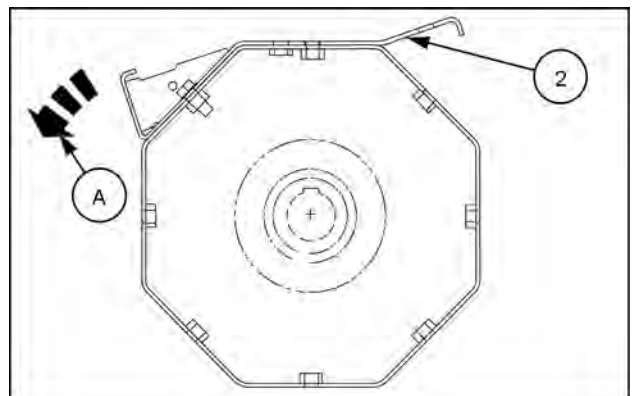

ZEIL14CXF0038AA 3

Swath rake - Visual inspection

CR6.80	NA
CR6.90	NA
CR7.90	NA
CR8.90	NA
CR9.90	NA

Prior operation:

Swath rake - Remove (73.220).

1. Inspect baffle (1) for damage. Replace as necessary.
2. Inspect rubber seal (2) on both sides of the baffle (1). Replace if worn or damaged.

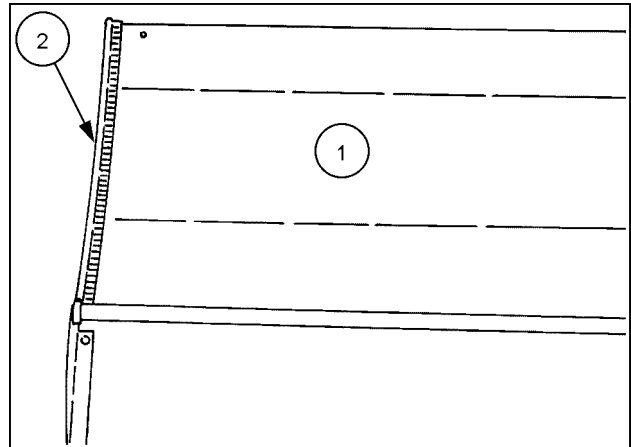

20023067 1

Next operation:

Swath rake - Install (73.220).

3. The reading on the pressure gauge should be approximately **200 bar (2900 psi)**. If the pressure gauge reading is not correct, replace the relief valve **(1)**.

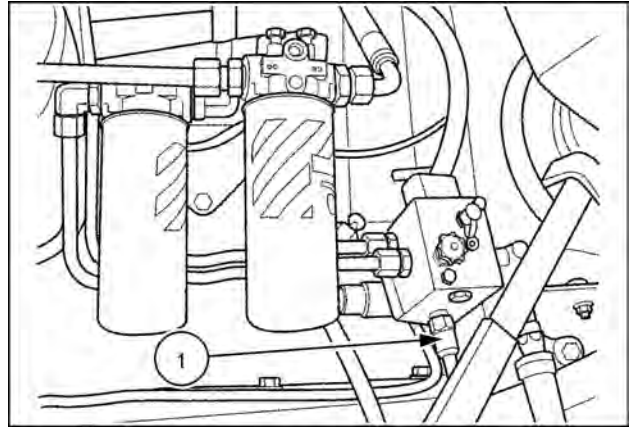

73076708 2

Next operation:
Return auger drive Gearbox - Install (74.101)

Clean grain cross auger drive system - Visual inspection - Clutch exterior

CR6.80	NA
CR6.90	NA
CR7.90	NA
CR8.90	NA
CR9.90	NA

External housing inspection

1. Clean the exterior of clutch housing.
2. Inspect the clutch assembly for discolored or scorched paint.

NOTE: Typically, this clutch should not experience large amounts of heat. Any indication of exterior scorching indicates that the clutch has operated excessively, resulting in an internal failure producing excessive heat that will have affected the internal parts, causing them to lose their hardness. Corrective action to the cross or returns auger(s) and/or complete slip clutch replacement may be required.

Next operation:

Clean grain cross auger drive system - Disassemble - Pin clutch (74.101).

Upper shoe support arm shoe connection (1) and upper shoe support arm frame connection (2)

3. Maintain a distance of **4 - 6 mm (5/32 - 1/4 in)** between the bottom of the bushing and the surface of the support arm.
4. Maintain a distance of **18 - 20 mm (23/32 - 25/32 in)** between the bottom of the bushing and the surface of the support arm.

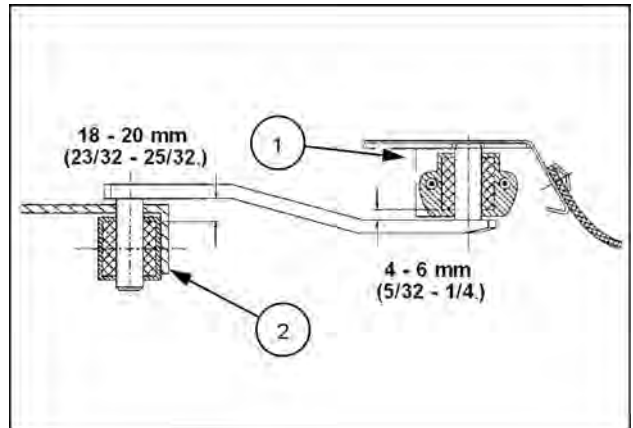

20013962_1222 3

5. Attach the support arm (1) with the hardware and clamps (2) previously removed.

NOTE: Anytime a rubber bushing is replaced, the drive arm must be in the neutral position prior to tightening the clamp.

6. Rotate the leveling frame as required to gain access to the support arm attachment points.

NOTE: Do not tighten the hardware until instructed.

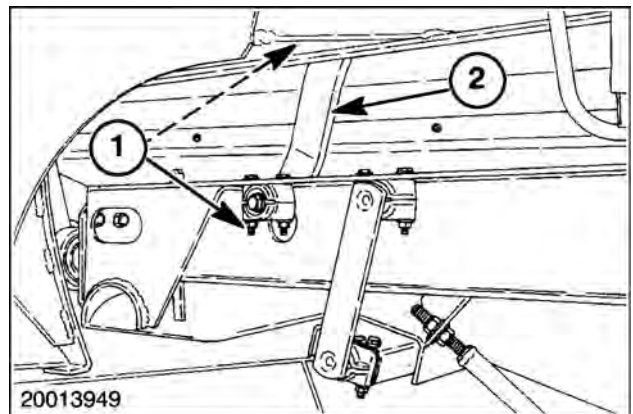

20013949 4

7. Position the drive arms so that the keyway is perpendicular to the arm in the neutral position.
8. Tighten the bushing clamp hardware while holding the drive arm in the neutral position to the torque found in the standard torque chart.

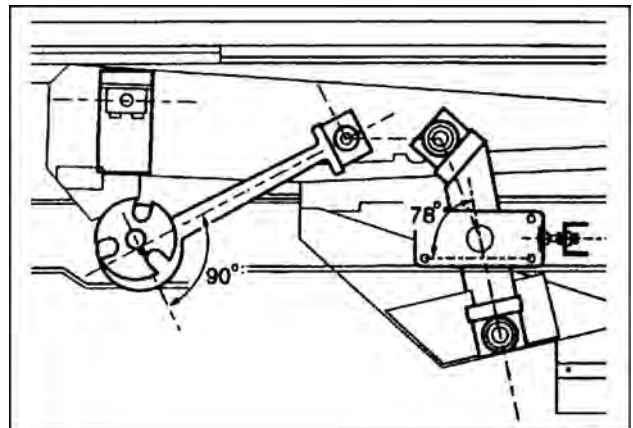

20013967_1224 5

Fan drive system - Flow test - Cleaning fan pump

CR6.80	NA
CR6.90	NA
CR7.90	NA
CR8.90	NA
CR9.90	NA

⚠ WARNING

Avoid injury!

Use extreme caution during this procedure. There is no relief valve in the system when using this test procedure. High pressure could damage the pump, resulting in flying pieces. **DO NOT** let pressure exceed 20000 kPA (2900 psi).

Failure to comply could result in death or serious injury.

W1146A

⚠ WARNING

Maintenance hazard!

Two persons are required to safely perform the flowmeter tests. One person must be seated in the operator's seat with the engine running. The second person must control the flowmeter and take the readings.

Failure to comply could result in death or serious injury.

W1145A

The cleaning fan pump flow test is used to determine the efficiency of the cleaning fan hydraulic drive pump in stand-alone mode. The test is a follow-up to the flow test on the fan drive system performed on the motor. Refer to **Fan housing - Flow test - Hydraulic cleaning fan (74.130)**. The test may be performed if the system pressure is not up to specification and there is suspicion that the pump itself may be at fault.

NOTE: There is oil present in the hydraulic lines. Have appropriate receptacles present to catch any spillage that occurs during the removal of the hydraulic lines.

1. Locate the cleaning fan control valve (1) on the left-hand side of the combine..

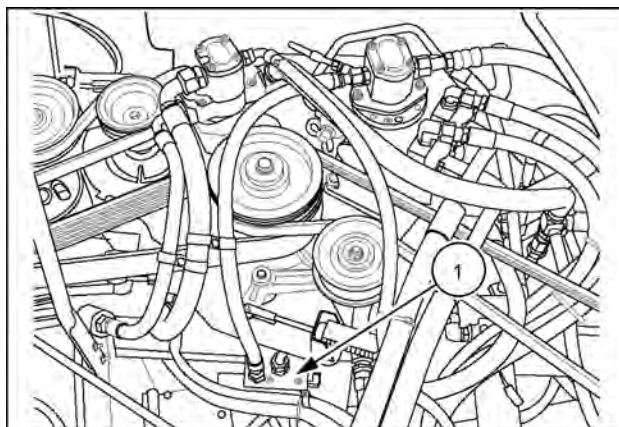

73076725 1

16. Adjust the grain elevator chain with nut **(1)** and nut **(2)** at the rear of the grain elevator.

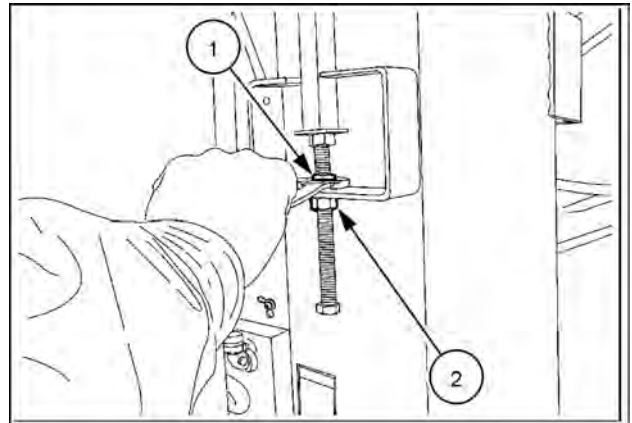

ZDA2922A 11

17. Adjust the grain elevator intermediate shaft drive belt tension with nut **(1)** to the specified length on the indicator plate on the adjustment rod.

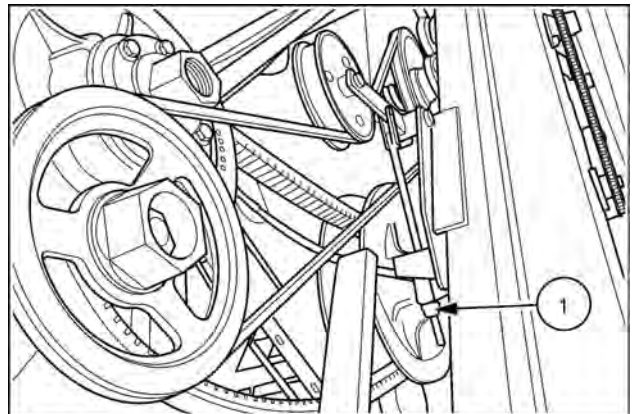

13020117 12

Assemble (*)	52
Backlash (*)	57
Gear tooth contact (*)	59
Grain discharge horizontal tube - Install - Standard capacity unload tube (*)	61
Grain discharge horizontal tube - Install - Extension tube for high capacity unload tube (*)	64
Grain discharge horizontal tube - Install - High capacity unloading tube (*)	66
Unloading tube gearbox	
Remove (*)	69
Disassemble (*)	70
Assemble (*)	72
Install (*)	78
Filling (*)	79

(*) See content for specific models

7. Loosen the lock collar (1) and adjust the auger (2) to the bottom against the gearbox hub.
8. Tighten the lock collar (1).

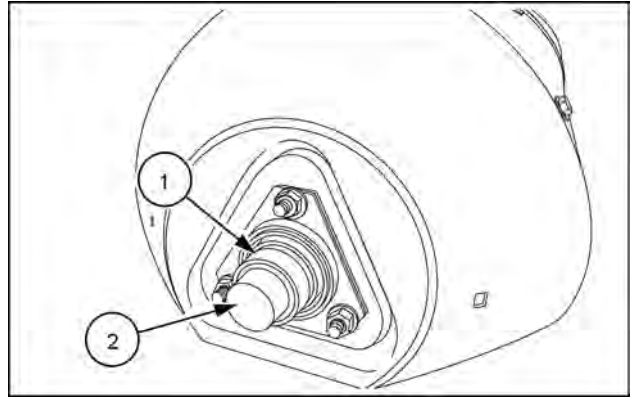

NHIL13AF01363AA 8

9. Install the access cover (1) with two M8 x 16 carriage bolts, M8 nuts, and M8 Belleville washers (2).

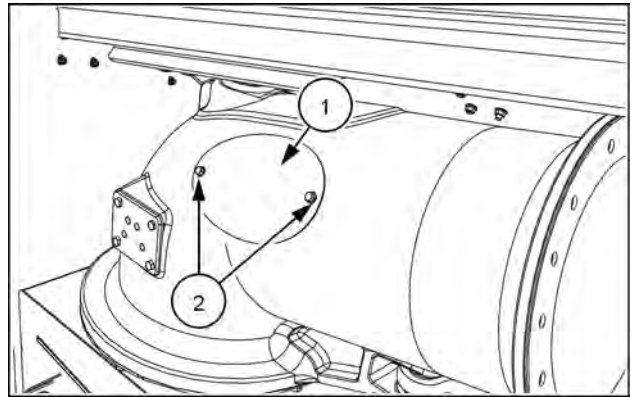

NHIL14AF01714AA 9

10. Connect unloading light wiring harness (1).

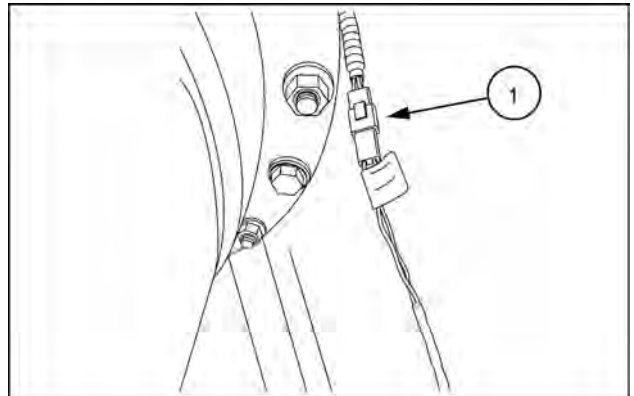

NHIL13AF01367AA 10

11. Adjust the band assembly as needed so that the pin (1) lines up with the mount (2) on the combine.
12. Tighten the hardware that secures the band clamp to **27 N·m (239 lb in)**.
13. Tighten all hardware to the torque found in the standard torque chart.

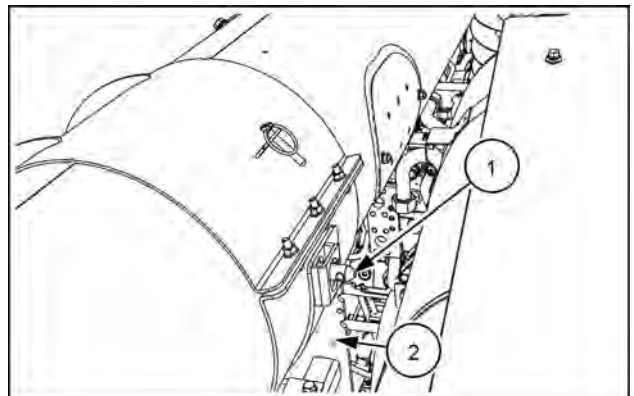

NHIL14AF01211AA 11

CLICK HERE TO **DOWNLOAD** THE COMPLETE MANUAL

- Thank you very much for reading the preview of the manual.
- You can download the complete manual from: www.heydownloads.com by clicking the link below



- Please note: If there is no response to CLICKING the link, please download this PDF first and then click on it.

CLICK HERE TO **DOWNLOAD** THE COMPLETE MANUAL