

SERVICE MANUAL

B95C / B95CTC / BI10C

Tier 4B (final)

Tractor Loader Backhoe

Part number 47830959

English

April 2015



CLICK HERE TO **DOWNLOAD** THE COMPLETE MANUAL

- Thank you very much for reading the preview of the manual.
- You can download the complete manual from: www.heydownloads.com by clicking the link below



- Please note: If there is no response to CLICKING the link, please download this PDF first and then click on it.

CLICK HERE TO **DOWNLOAD** THE COMPLETE MANUAL

Protecting the electronic and/or electrical systems during charging and welding

To avoid damage to the electronic and/or electrical systems, always observe the following practices:

1. Never make or break any of the charging circuit connections when the engine is running, including the battery connections.
2. Never short any of the charging components to ground.
3. Always disconnect the ground cable from the battery before arc welding on the machine or on any machine attachment.
 - Position the welder ground clamp as close to the welding area as possible.
 - If you weld in close proximity to a computer module, then you should remove the module from the machine.
 - Never allow welding cables to lie on, near, or across any electrical wiring or electronic component while you weld.
4. Always disconnect the negative cable from the battery when charging the battery in the machine with a battery charger.

NOTICE: *If you must weld on the unit, you must disconnect the battery ground cable from the machine battery. The electronic monitoring system and charging system will be damaged if this is not done.*

5. Remove the battery ground cable. Reconnect the cable when you complete welding.

⚠ WARNING

Battery acid causes burns. Batteries contain sulfuric acid.

Avoid contact with skin, eyes or clothing. Antidote (external): Flush with water. Antidote (eyes): flush with water for 15 minutes and seek medical attention immediately. Antidote (internal): Drink large quantities of water or milk. Do not induce vomiting. Seek medical attention immediately.

Failure to comply could result in death or serious injury.

W0111A

Special tools

The special tools that NEW HOLLAND CONSTRUCTION suggests and illustrate in this manual have been specifically researched and designed for use with NEW HOLLAND CONSTRUCTION machines. The special tools are essential for reliable repair operations. The special tools are accurately built and rigorously tested to offer efficient and long-lasting operation.

By using these tools, repair personnel will benefit from:

- Operating in optimal technical conditions
- Obtaining the best results
- Saving time and effort
- Working in safe conditions

Consumables

Dye and black light procedure for detecting oil leaks

Oils and grease have natural phosphors and will illuminate differently under the black light. Oil, bluish-white, grease, brilliant-white, anti-freeze, greenish-yellow, sealing compounds, red to orange.

Kit part number 380040182 consisting of:

Part Number	Description	Unit of measurement	Comments	Usage
380002254	Black Light	—	12 Volt Ultra Violet Light	—
380002357	Dye-uniglow F2HF	10 ml (0.34 US fl oz)	Glow Green in Black Light	Engine Oil / Crankcase
380002358	Dye-uniglow F4HF	65 ml (2.2 US fl oz)	Glow Yellow in Black Light	Hydraulic Oil
380002359	Dye-uniglow 1750	10 ml (0.34 US fl oz)	Glow Purple in Black Light	Transmission Oil

NOTE: Each dye is formulated to work in conjunction with a specific fluid, therefore the dyes are not interchangeable and should only be used as described.

1. Prior to adding dye, connect the black light to the machines battery and investigate suspected areas.
2. Once suspected leak areas are found, attempt to trace the leak completely to the origin.

NOTE: At the origin, the leak should be the brightest in color.

3. After confirmation of the suspected leak, thoroughly clean the area of the leak to remove any existing fluids. Recheck the area with the black light to assure the area is clean. Good cleaning is important for the following reasons:

- Fluids captured by threaded joints or other cavities will continue to show signs of leakage unless completely clean.
- Casting surfaces can hold residual oil.

4. Use the entire contents of the bottle of dye in the system/systems of the suspected leak.
5. Run the unit for 5 to 10 minutes and cycle through suspect system functions to ensure that the dye is available to all possible leak points.

NOTE: The hydraulic oil should be heated to 71 °C (160 °F), engine at normal operating temperature, and transmission should be in the normal operating range on the gauge.

6. Use a clean cloth and wipe the dipstick or the inside surface of the filler tube on each of the 3 sumps.
7. View traces of dyed fluid on the cloth under the black light to ensure good samples.

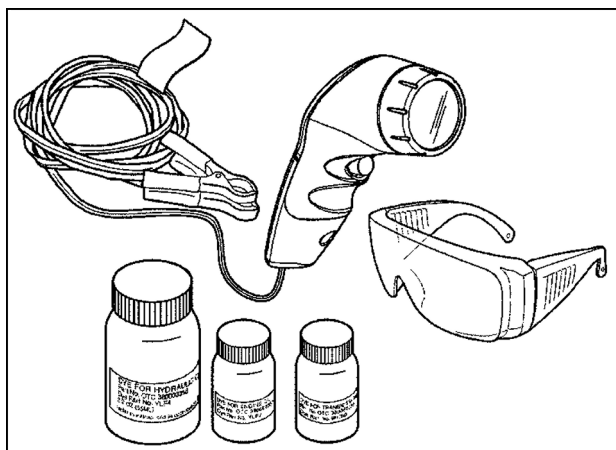

RCPH10TLB245ACL 1

9. Connect the connector X-508 on the starter motor and the ignition connector.

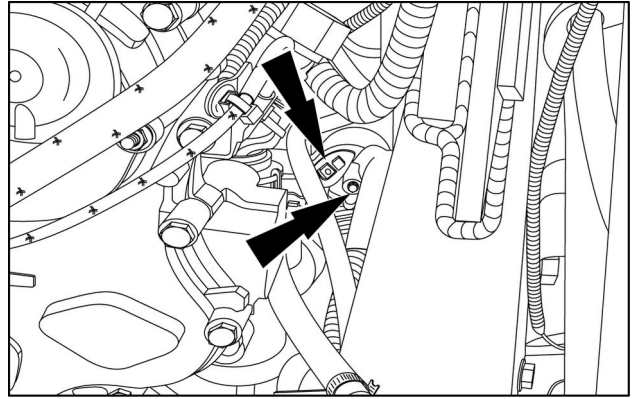

RAIL15TLB0241AA 9

10. Connect the connectors X-67 and X-10 to the alternator.

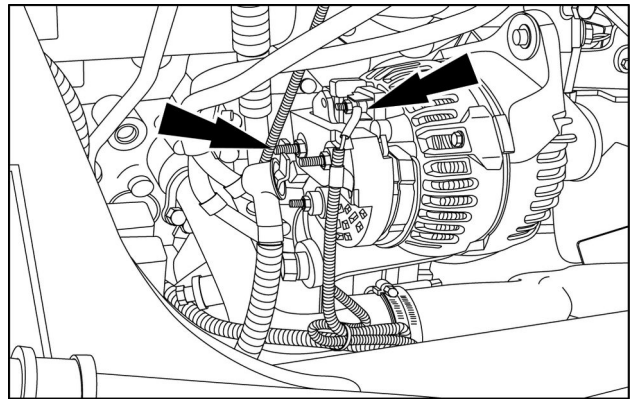

RAIL15TLB0233AA 10

11. Connect the ground strap.

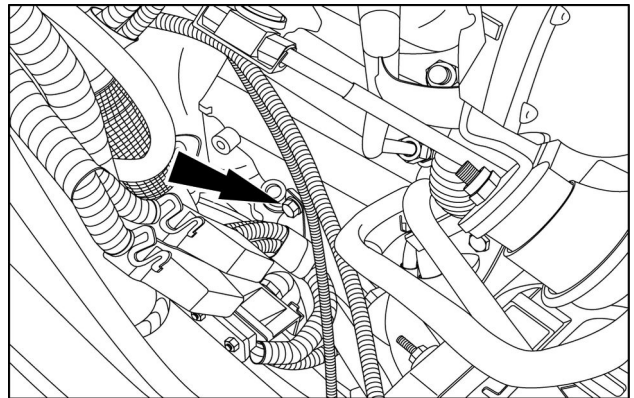

RAIL15TLB0235AA 11

12. Connect the fuel line (1) to the cylinder head. Connect the fuel lines (2) to the fuel filter.

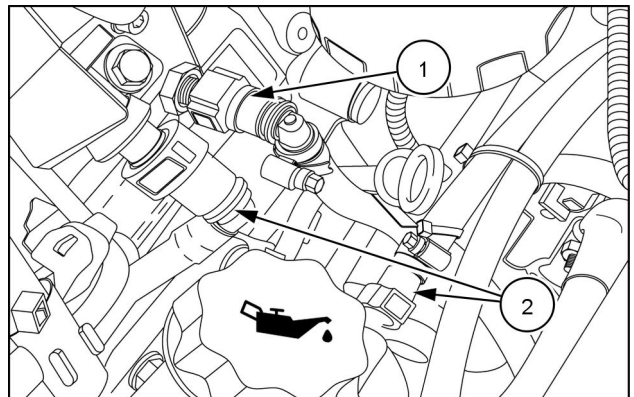

RAIL15TLB0240AA 12

Index

Engine - 10

Fuel injection system - 218

Fuel injection system - Bleed	3
-------------------------------------	---

Diesel Exhaust Fluid (DEF)/AdBlue® lines - Cleaning filter

1. Move the machine to a level and firm surface.
2. Lower the loader attachment to the ground.
3. Place the backhoe attachment in the road travel position.
4. Place the direction-of-travel lever and gearshift lever in the neutral position.
5. Engage the parking brake.
6. Stop the engine and remove the starter switch key
7. Switch the master disconnect to the off position.

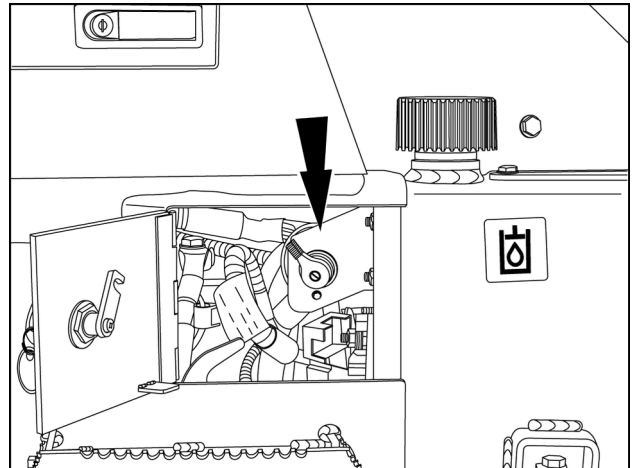

RAIL15TLB0014AA 1

8. Remove the bolts from the cover plate to access the sending unit.

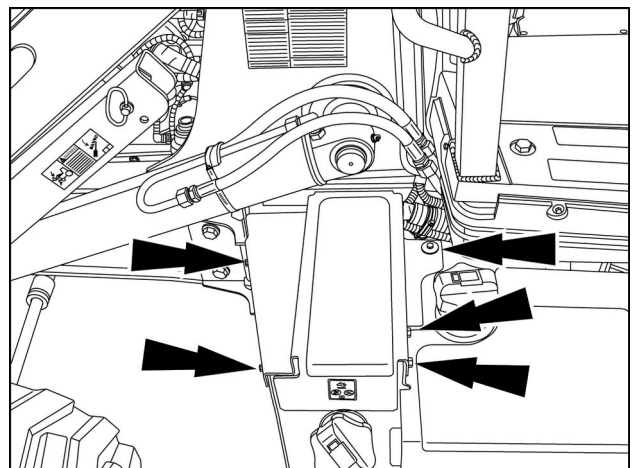

RAIL15TLB0081AA 2

9. Install the upper radiator hose.

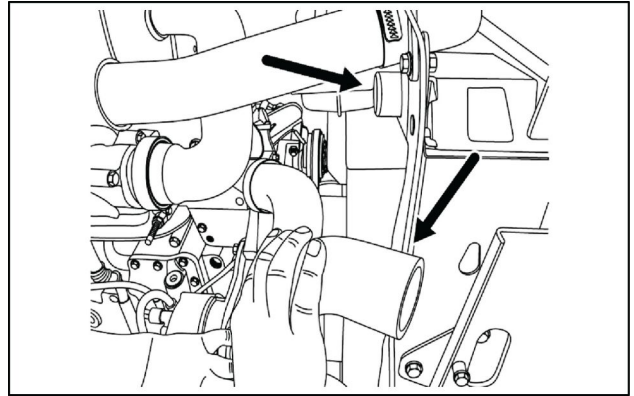

LEL12TLB0025AA 9

10. Install the hood support and secure with the bolts (1) removed earlier.

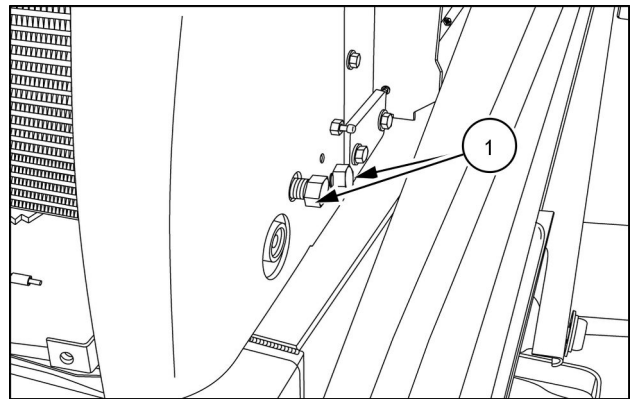

RAIL15TLB0199AA 10

11. Connect the connector X-2 to the horn.

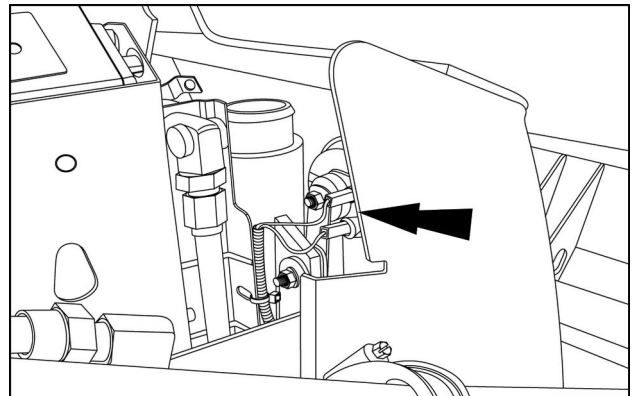

RAIL15TLB0191AA 11

12. Connect the air intake duct to the air filter.

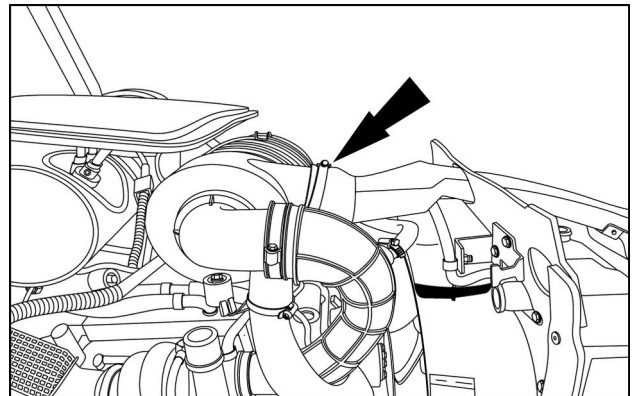

RAIL15TLB0195AA 12

Description	Amber telltale LED	Red telltale LED
4035 - Shifter Lever malfunction: transmission in reverse receives neutral and reverse together		X
4036 - During transition from second to third gear, and Gear CMD_01 signal erratic or incorrect	X	
4037 - During transition from first to second gear, and Gear CMD_02 signal erratic or incorrect	X	
4038 - During transition from third to fourth gear, and Gear CMD_02 signal erratic or incorrect	X	
4040 - Transmission Controller Driveline Configuration	X	
4041 - Transmission output shaft frequency above 3000 Hz detected	X	
4042 - Temperature signal erratic or incorrect	X	
4043 - Temperature sensor input (Pin 43) is shorted to a ground	X	
4044 - Temperature sensor input (Pin 43) is open circuit or shorted to a voltage above 5 volts	X	
4045 - Charge pressure is not detected when engine speed is above 700 rpm for 10 seconds		X
4046 - Charge pressure is not detected and vehicle speed is over 10 kph (6 mph)	X	
4047 - Charge pressure switch is closed with no frequency input to the TRAX controller		X
4054 - Unknown vehicle model value from VCM	X	
4101 - Internal TRAX failure, hardware measurement		X
4102 - Internal TRAX failure, software timing		X
4103 - Internal TRAX failure, software not running		X
4105 - Internal TRAX failure, redundant flash memory		X
4106 - Internal TRAX failure, sensor supply high		X
4107 - Internal TRAX failure, sensor supply low		X
4200 - First shift solenoid shorted to ground		X
4201 - Second or Third shift solenoid shorted to ground		X
4203 - Fourth shift solenoid shorted to ground		X
4204 - System detects different gear than commanded		X
4205 - System can not engage required gear. (Engaged gear is different than requested gear)	X	
4206 - Gear engagement failed		X
4207 - 1ST/2ND gear shift rail position reporting first gear at startup		X
4208 - 1ST/2ND gear shift rail position reporting second gear at startup		X
4209 - 3RD/4TH gear shift rail position reporting third gear at startup		X
4210 - 3RD/4TH gear shift rail position reporting forth gear at startup		X
4211 - First and second gear sensor input shorted to ground		X
4212 - First and second gear sensor input voltage too high		X
4213 - Third and forth gear sensor input shorted to ground		X
4214 - Third and forth gear sensor input voltage too high		X
4300 - CANBus speed sensor message missing		X
4301 - CANBus speed sensor frequency input out of range		X
4302 - CANBus speed sensor frequency input erratic		X
4303 - CANBus speed sensor frequency input abnormal rate of change		X
4304 - CANBus speed sensor supply voltage too low.		X
4305 - CANBus speed sensor supply voltage too high.		X
4306 - CANBus speed sensor can not recover		X
4825 - Loss of TC1 message after 15 seconds	X	

32. Secure that retainers on the gearshift pins with the pins (18).

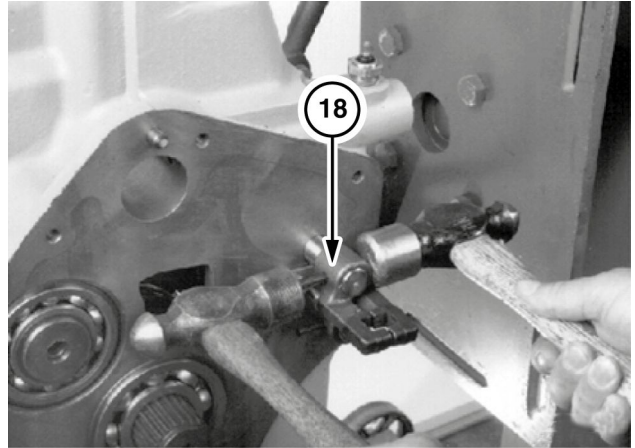

LEPH12TLB0571AB 28

33. Apply a thin film of sealant on the edge of the rear cover (16).

34. Install the O-ring (17).

NOTE: Do not grease the O-ring.

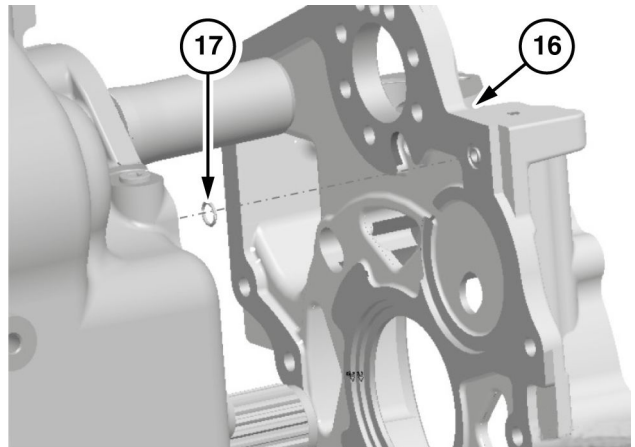

LEPH12TLB0572AB 29

35. Install the rear cover (16) with the bolts (15).

NOTICE: Make sure that the gearshift pins are installed in its correct position in the rear cover.

36. If necessary, tap the rear cover with a soft faced hammer to close the gap between the rear half housing and the rear cover to tighten the cap screws.

37. Torque the bolts (15) to 80 N·m (59 lb ft).

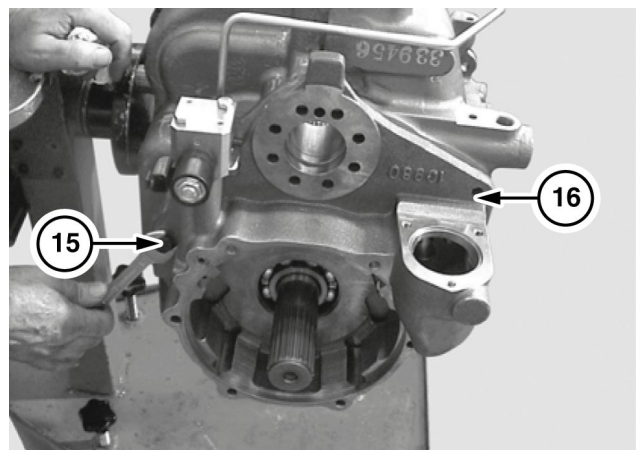

LEPH12TLB0538AB 30

Power shuttle transmission - Troubleshooting

B110C TIER 4B (FINAL), Mechanical Controls, Four-Wheel Drive (4WD), Power Shuttle, Cab	
B110C TIER 4B (FINAL), Mechanical Controls, Four-Wheel Drive (4WD), Power Shuttle, Canopy	
B110C TIER 4B (FINAL), Pilot Controls, Four-Wheel Drive (4WD), Power Shuttle, Cab	
B110C TIER 4B (FINAL), Pilot Controls, Four-Wheel Drive (4WD), Power Shuttle, Canopy	
B110C TIER 4B (FINAL), Pilot Controls, Two-Wheel Drive (2WD), Power Shuttle, Cab	
B95C TC TIER 4B (FINAL), Mechanical Controls, Four-Wheel Drive (4WD), Power Shuttle, Cab	
B95C TC TIER 4B (FINAL), Mechanical Controls, Four-Wheel Drive (4WD), Power Shuttle, Canopy	---
B95C TC TIER 4B (FINAL), Pilot Controls, Four-Wheel Drive (4WD), Power Shuttle, Canopy	
B95C TIER 4B (FINAL), Mechanical Controls, Four-Wheel Drive (4WD), Power Shuttle, Cab	
B95C TIER 4B (FINAL), Mechanical Controls, Four-Wheel Drive (4WD), Power Shuttle, Canopy	
B95C TIER 4B (FINAL), Mechanical Controls, Two-Wheel Drive (2WD), Power Shuttle, Cab	
B95C TIER 4B (FINAL), Mechanical Controls, Two-Wheel Drive (2WD), Power Shuttle, Canopy	
B95C TIER 4B (FINAL), Pilot Controls, Four-Wheel Drive (4WD), Power Shuttle, Cab	
B95C TIER 4B (FINAL), Pilot Controls, Four-Wheel Drive (4WD), Power Shuttle, Canopy	
B95C TIER 4B (FINAL), Pilot Controls, Two-Wheel Drive (2WD), Power Shuttle, Cab	
B95C TIER 4B (FINAL), Pilot Controls, Two-Wheel Drive (2WD), Power Shuttle, Canopy	

Problem	Possible Cause	Correction
The vehicle does not move	Control valve supply problem	Check and, if necessary, replace the control valves
	Damaged connections of transmission and vehicle wiring harness	Repair and, if necessary, replace the wiring harness
	Oxidation in the contacts of the electric cables of the wiring harness	Clean the contacts
	Interruption of the electric cable	Replace the electric cable
	Damage to the solenoid valves	Replace the solenoids
	Damage to sensors	Replace sensors
	Short circuits or bad contact	Check and, if necessary, replace the fuses
	Incorrect oil level	Restore the oil level
	Check for possible oil leaks	Eliminate the leaks and restore the oil level
	Suction strainer restriction	Clean the suction strainer
	Damaged oil pump	Replace the oil pump
	Damaged oil pump pressure relief valve	Replace the oil pump
	Damaged \ restricted filter	Replace the filter
	Damaged \ stuck control valve	Replace the control valve
	Damaged converter	Replace the converter
	Oil temperature below 0 °C (32 °F)	Wait for the operating temperature to be reached (stall test)
	Damaged rotary seal rings	Replace the rotary seal rings
	Synchronizers damaged	Replace the synchronizers
	Stuck shuttle lever	Repair the shuttle lever
	Excessively worn-out clutch assembly	Repair and, if necessary, replace the clutch disc kit
Lack of motion transmission (broken gears, shafts, bearings, etc.)	Check, repair and, if necessary, replace	

20. Remove the gasket (35).

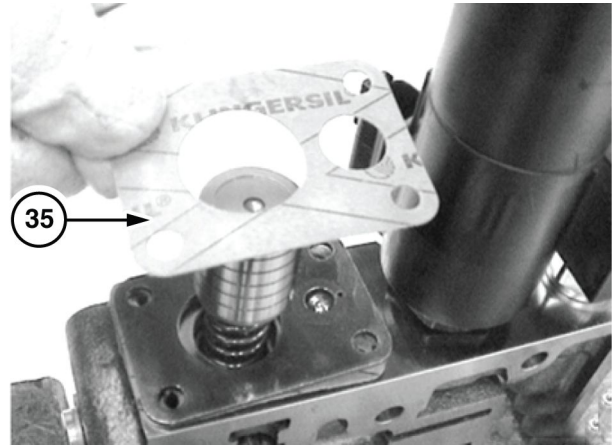

LEPH12TLB0389AB 15

21. Remove the plate (36).

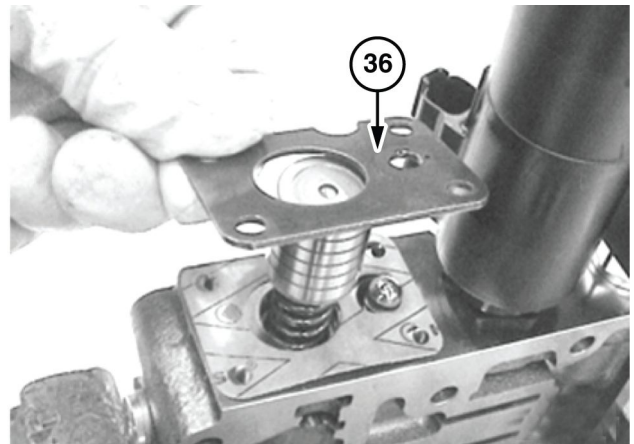

LEPH12TLB0389AB 16

22. Remove the outer piston (38), the springs (39), (40) and (41), the pin (42) and the inner piston (43).

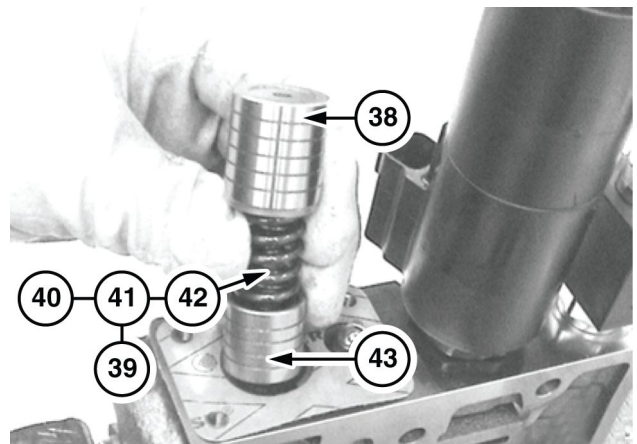

LEPH12TLB0391AB 17

Power shuttle transmission lubrication system - Change fluid

B110C TIER 4B (FINAL), Mechanical Controls, Four-Wheel Drive (4WD), Power Shuttle, Cab	
B110C TIER 4B (FINAL), Mechanical Controls, Four-Wheel Drive (4WD), Power Shuttle, Canopy	
B110C TIER 4B (FINAL), Pilot Controls, Four-Wheel Drive (4WD), Power Shuttle, Cab	
B110C TIER 4B (FINAL), Pilot Controls, Four-Wheel Drive (4WD), Power Shuttle, Canopy	
B110C TIER 4B (FINAL), Pilot Controls, Two-Wheel Drive (2WD), Power Shuttle, Cab	
B95C TC TIER 4B (FINAL), Mechanical Controls, Four-Wheel Drive (4WD), Power Shuttle, Cab	
B95C TC TIER 4B (FINAL), Mechanical Controls, Four-Wheel Drive (4WD), Power Shuttle, Canopy	---
B95C TC TIER 4B (FINAL), Pilot Controls, Four-Wheel Drive (4WD), Power Shuttle, Canopy	
B95C TIER 4B (FINAL), Mechanical Controls, Four-Wheel Drive (4WD), Power Shuttle, Cab	
B95C TIER 4B (FINAL), Mechanical Controls, Four-Wheel Drive (4WD), Power Shuttle, Canopy	
B95C TIER 4B (FINAL), Mechanical Controls, Two-Wheel Drive (2WD), Power Shuttle, Cab	
B95C TIER 4B (FINAL), Mechanical Controls, Two-Wheel Drive (2WD), Power Shuttle, Canopy	
B95C TIER 4B (FINAL), Pilot Controls, Four-Wheel Drive (4WD), Power Shuttle, Cab	
B95C TIER 4B (FINAL), Pilot Controls, Four-Wheel Drive (4WD), Power Shuttle, Canopy	
B95C TIER 4B (FINAL), Pilot Controls, Two-Wheel Drive (2WD), Power Shuttle, Cab	
B95C TIER 4B (FINAL), Pilot Controls, Two-Wheel Drive (2WD), Power Shuttle, Canopy	

Change the transmission fluid as follows:

1. Move the machine to a level and firm ground.
2. Raise the loader attachment and assemble the safety support strut.
3. Place the backhoe attachment in the road travel position.
4. Place the direction-of-travel lever and gearshift lever in neutral position.
5. Apply the parking brake.
6. Stop the engine and remove the starter key.
7. Open and raise the engine hood and lock it in opened position by means of the safety lock on the left-hand gas spring.
8. Remove the dipstick (1).

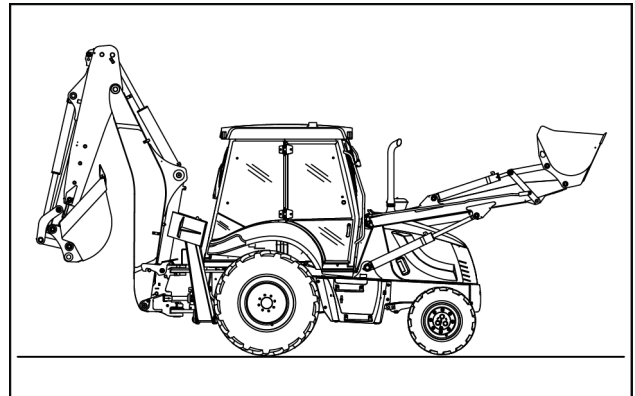

RAIL14TLB0152AA 1

NOTE: Change the oil while the transmission is still warm; the oil will flow more easily.

9. Place a container with suitable capacity under the drain plug (2).
10. Remove the drain plug and let the transmission oil drain.

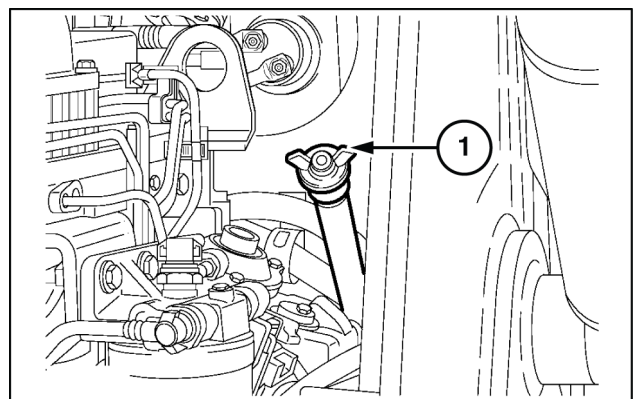

LELI12TLB0339AB 2

A, D shafts

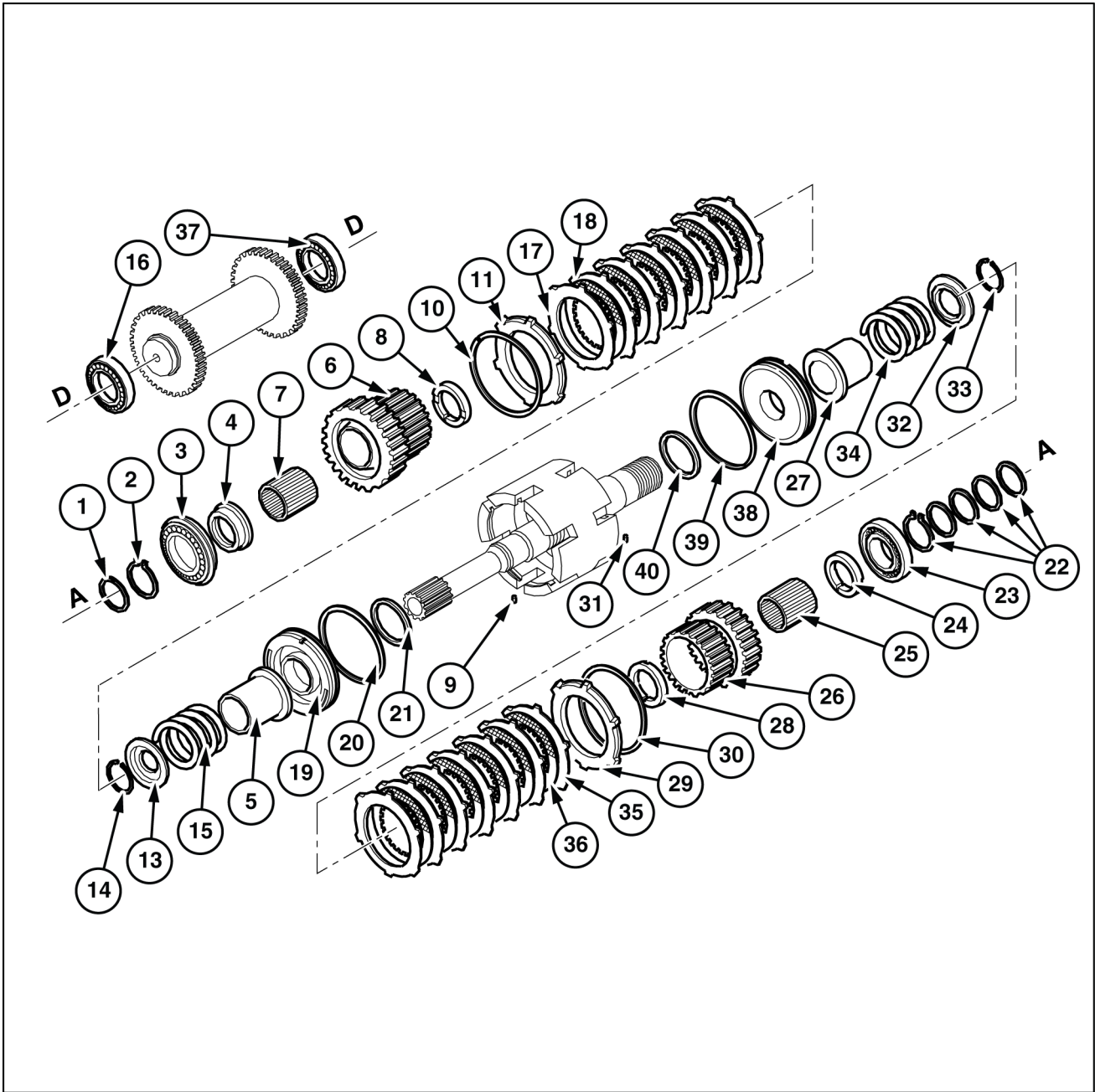

LELI12TLB0574GB 1

40. Remove the snap ring (38).

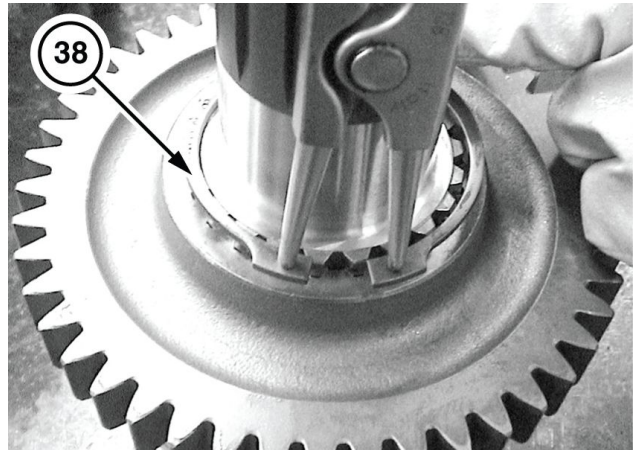

LEPH12TLB0459AB 63

41. Remove the Four-Wheel Drive (4WD) gear (14).

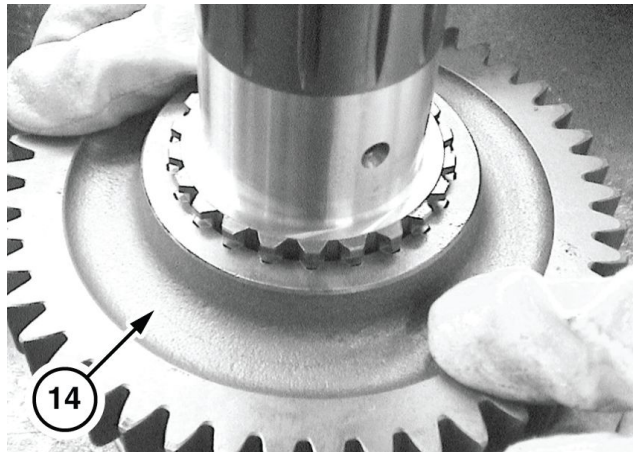

LEPH12TLB0460AB 64

42. Remove the snap ring (13).

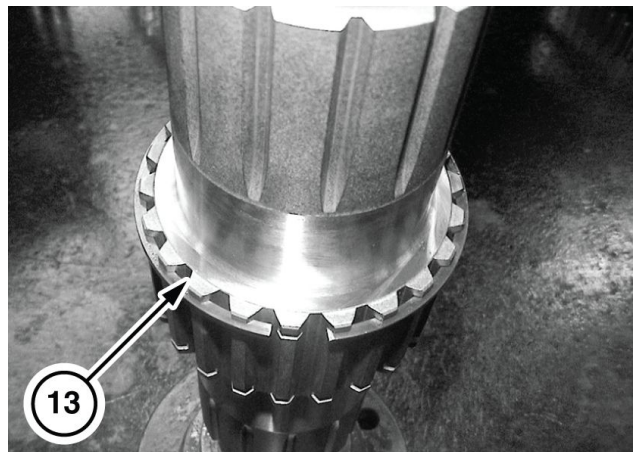

LEPH12TLB0461AB 65

22. Install the 2nd speed gear (18).

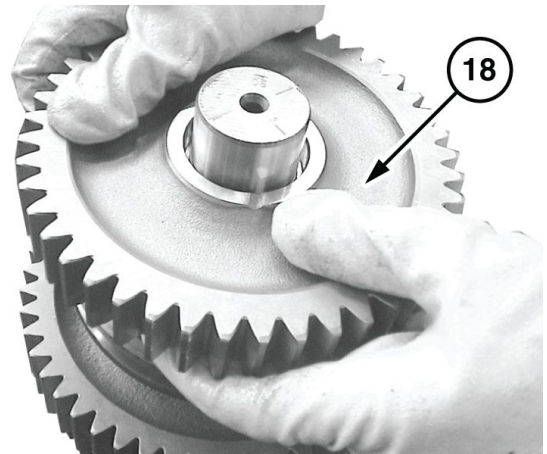

LEPH12TLB0446AB 55

23. Install the pin (19).

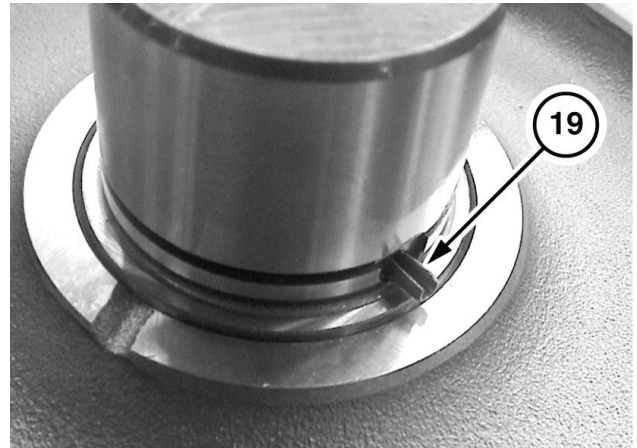

LEPH12TLB0446AB 56

24. Install the thrust washer (17) and the shims (20).

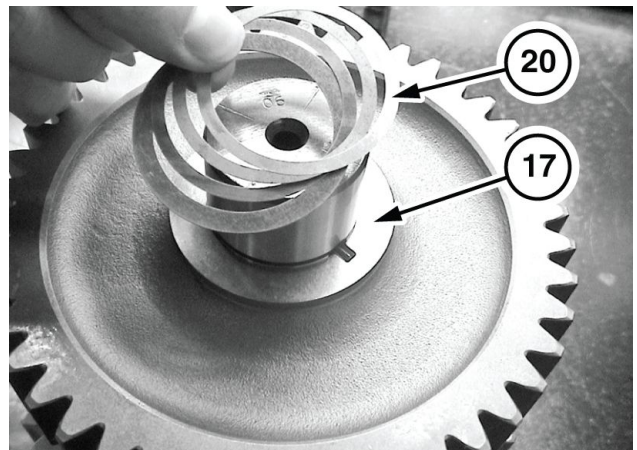

LEPH12TLB0467AB 57

Transmission - Powershift transmission

Ref.	Description	Notes
1.	Suction filter	250 N·m (184.39 lb ft)
2.	Pump	36 cm³/rev (2.20 in³/rev)
3.	Oil filter relief valve	23 bar (334 psi)
4.	Filter	10 N·m (7.4 lb ft)
5.	Torque converter	
6.	Oil cooler	
7.	Torque converter relief valve	5.5 bar (80 psi)
8.	Pressure regulator for sequential valve	
9.	Air breather	
10.	Forward gear pressure check port	
11.	Reverse gear pressure check port	
12.	Forward gear clutch	
13.	Reverse gear clutch	
14.	4WD SAHR clutch	
15.	HDL	
16.	Shaft lubrication inlet	
17.	Brake oil return port	
18.	Transfer oil return port	
19.	Main pressure check port	
20.	Pressure check port of 1 st gear clutch	
21.	Pressure check port of 2 nd gear clutch	
22.	1 st gear clutch	
23.	2 nd gear clutch	
24.	3 rd gear clutch	
25.	4 th gear clutch	
26.	Main shaft lubrication	
27.	Output shaft lubrication	
28.	Temperature thermostat	
29.	Parking brake SAHR clutch	
30.	Parking brake solenoid valve	

21. Install the snap ring (10).

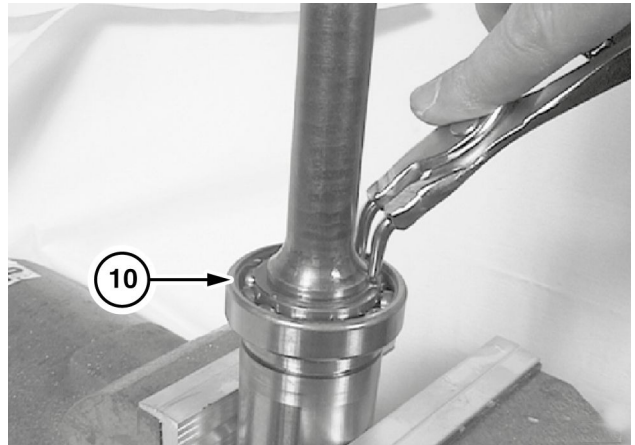

LEPH12TLB0862AB 20

22. To install the seal ring (9), use the following tools in sequence:

- 380200257
- 380200225
- 380200214

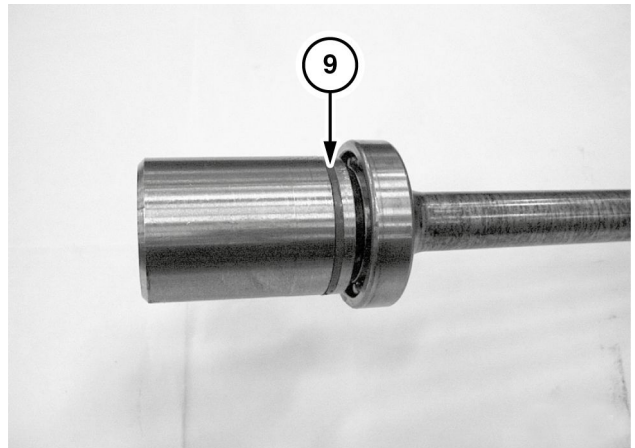

LEPH12TLB0863AB 21

23. Insert the PTO transmission shaft (8) on the stroke end.

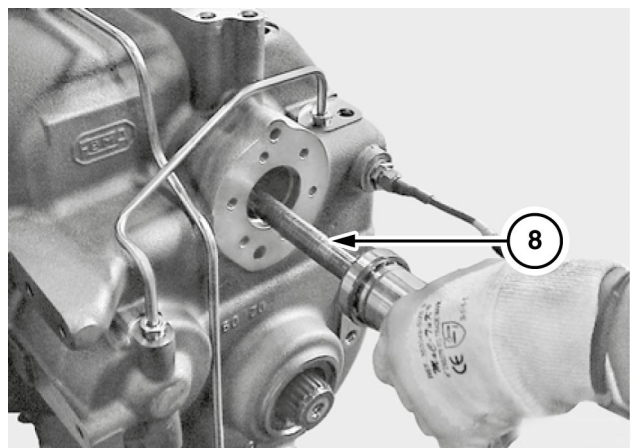

LEPH12TLB0864AB 22

Contents

Transmission - 21

Powershift transmission lubrication system - 105

FUNCTIONAL DATA

Powershift transmission lubrication system	
Component identification (*)	3
Identification (*)	4
Exploded view (*)	6
Exploded view – Hydraulic system lines (*)	7
Transmission lubrication pump	
Exploded view (*)	8

SERVICE

Powershift transmission lubrication system	
Check (*)	9
Change fluid (*)	10
Disassemble the filter, plugs and breather (*)	11
Assemble the filter, plugs and breather (*)	15
Remove the hydraulic system lines (*)	19
Install the hydraulic system lines (*)	22
Transmission lubrication pump	
Remove (*)	25
Install (*)	27

(*) See content for specific models

- Lubricate the seal ring **(4)** to keep it centred, in order to facilitate its introduction onto the oil pump.

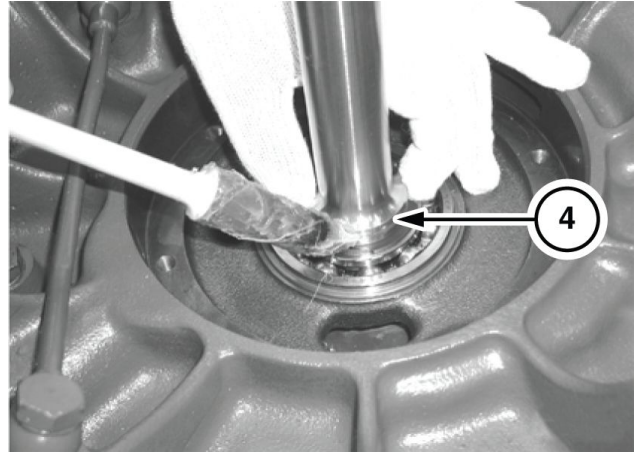

LEPH12TLB1124AB 4

- Lubricate the matching seat with the front half box.
- Install the oil pump **(2)** with the bolts **(1)**.

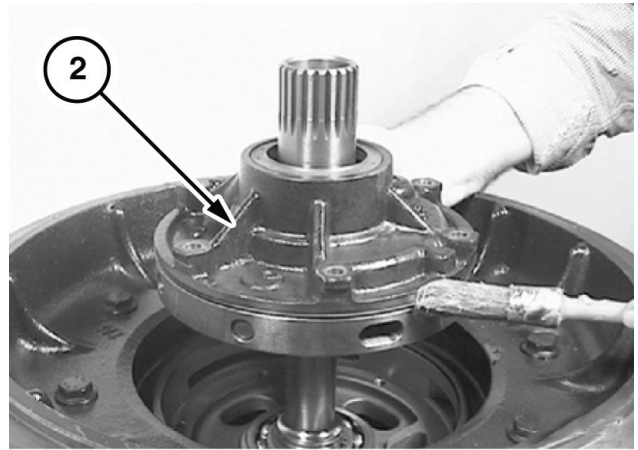

LEPH12TLB1125AB 5

- Torque the bolts **(1)** to **23 N·m (17 lb ft)**.

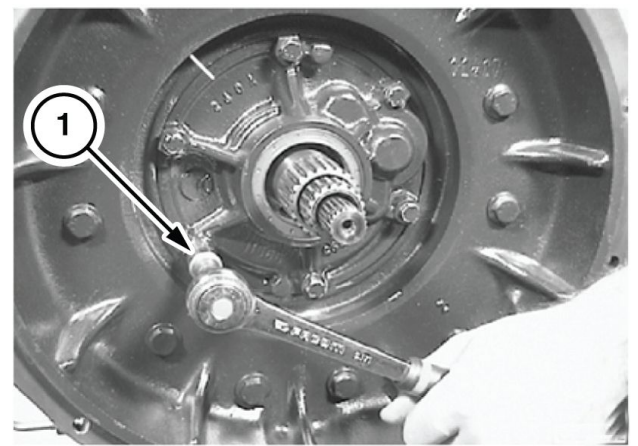

LEPH12TLB1126AB 6

Disassembly of shaft (B)

1. Remove the bolts (28) and remove the 4WD oil bulk-head (29).

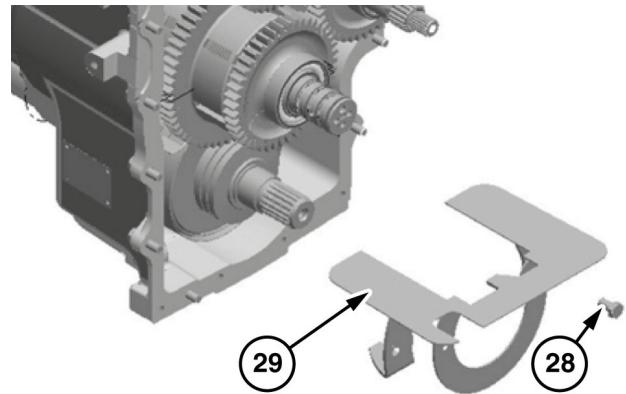

LEPH12TLB0875AB 35

2. Install the tool 380200256 on the side of the shaft (C) where the hub (27) is located.

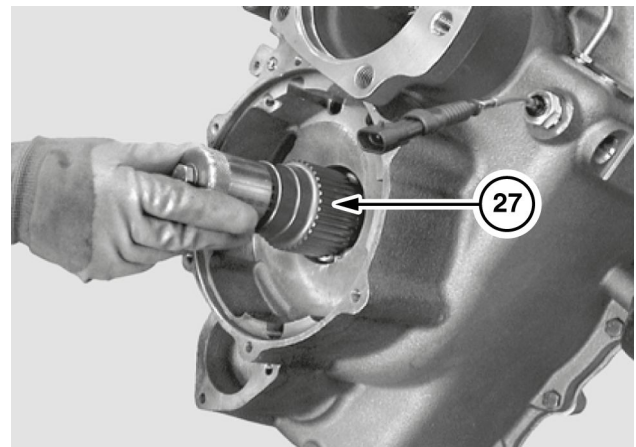

LEPH12TLB0876AB 36

3. Lift the shaft assemblies (B), (C) and (E) simultaneously with the tool 380200239.



LEPH12TLB0877AA 37

52. Remove the disc kit (6).



LEPH12TLB1261AB 109

53. Lower the cover (10) with the tool 380200215.

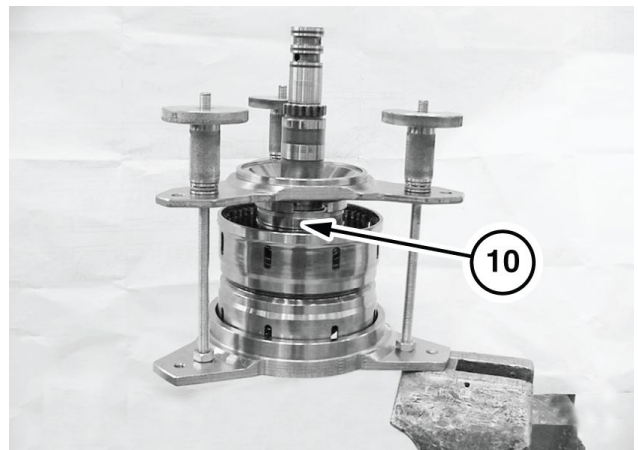

LEPH12TLB1262AB 110

54. Remove the snap ring (9).

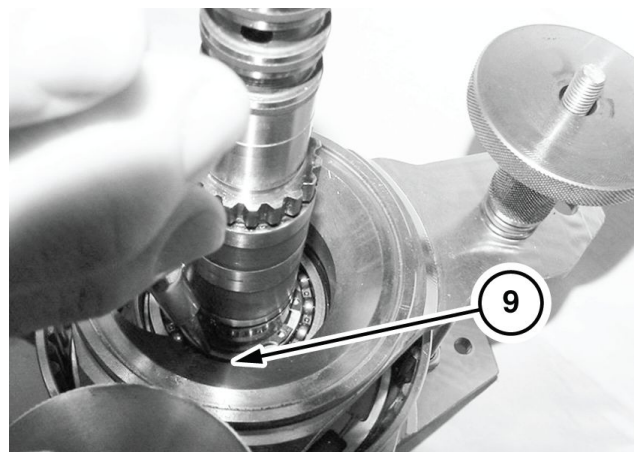

LEPH12TLB1263AB 111

31. Turn the seal compressor around and slide the end with the narrow chamfer over the shaft and over the seal ring.
32. Leave the seal compressor in place for **15 min** until the seal ring has cooled and is properly seated in the groove.
33. After the seal ring has cooled, remove the seal compressor from the shaft.

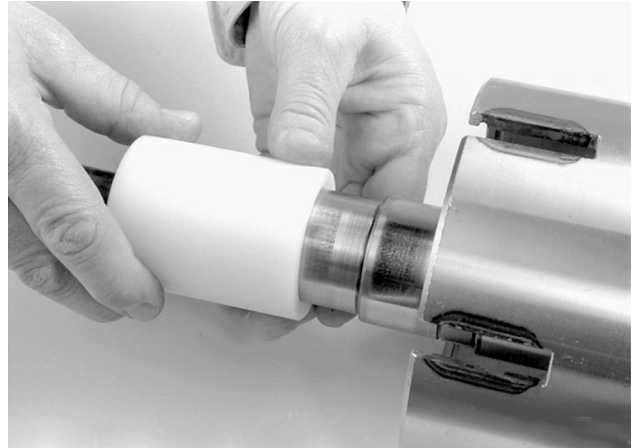

LEPH12TLB0822AA 25

34. Repeat steps **1** to **33** on the other side of the shaft.
35. Lubricate the thrust washer (**25**).
36. Install the thrust washer so that the notch in the inner edge fits over the pin.
37. Make sure that the side with the oil grooves is down.

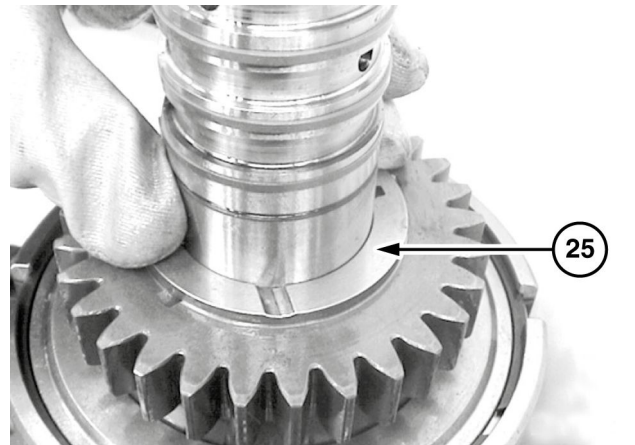

LEPH12TLB0823AB 26

38. Heat the bearing (**24**) to **80 - 100 °C (176 - 212 °F)**.
39. With the tool **380200197**, install the bearing (**24**) on the input shaft until it makes contact with the thrust washer.

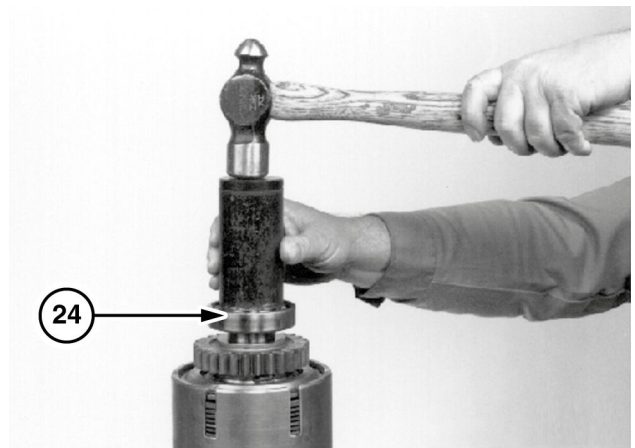

LEPH12TLB0824AB 27

35. Install new seal rings (49) and (51) on bushing (50) with the tools 380200251, 380200252 and 380200253.

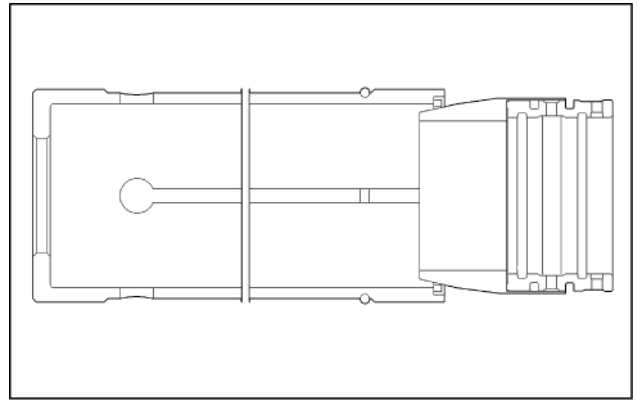

LEL112TLB0931AA 99

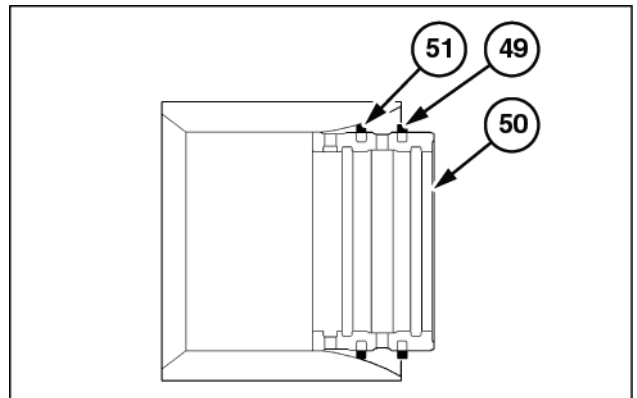

LEL112TLB0932A8 100

36. Install the bushing (50) and the shaft (23) with the tool 380200190.

37. The reference marks must be directed upwards.

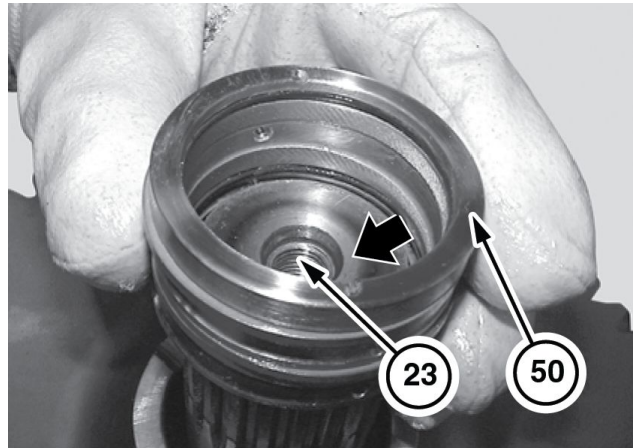

LEPH12TLB0933AB 101

38. Install the bushing (56) and bearing (55) with tool 380200190.

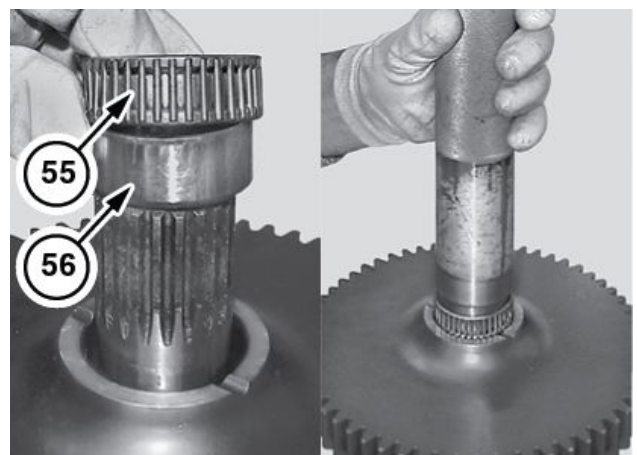

LEPH12TLB0934AB 102

14. Install the spacer (6), thrust washer (4) and snap ring (2).

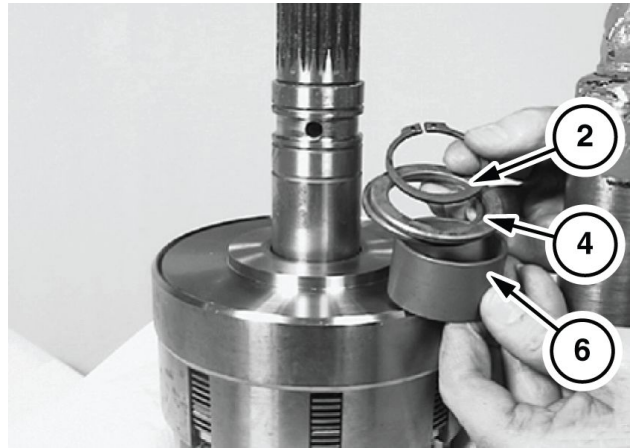

LEPH12TLB1295AB 173

15. With a thickness gauge determine the value of "X" between the thrust washer (4) and the snap ring (2).

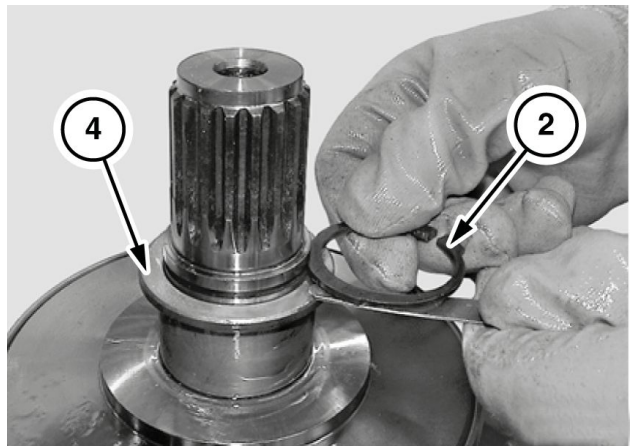

LEPH12TLB1045AB 174

16. To value "X" subtract the fixed measure "S1" of **1.80 mm (0.071 in)** corresponding to the piston stroke.

17. The resulting measure "S" corresponds to the height of the shim that must be inserted between the thrust washer (4) and the snap ring (2).
 $S = X - S1 = X - 1.80 \text{ mm (0.071 in)}$

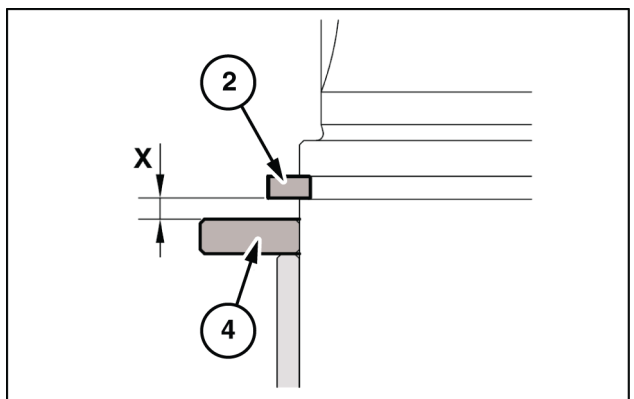

LEL12TLB118AB 175

18. Choose the shim with value "S" from the shim range available.

NOTE: In any case, choose the shim ensuring a piston stroke of **1.70 - 1.90 mm (0.067 - 0.075 in)**.

Shim range

- Shims **0.1 mm (0.004 in)**
- Shims **0.3 mm (0.012 in)**
- Shims **0.5 mm (0.020 in)**

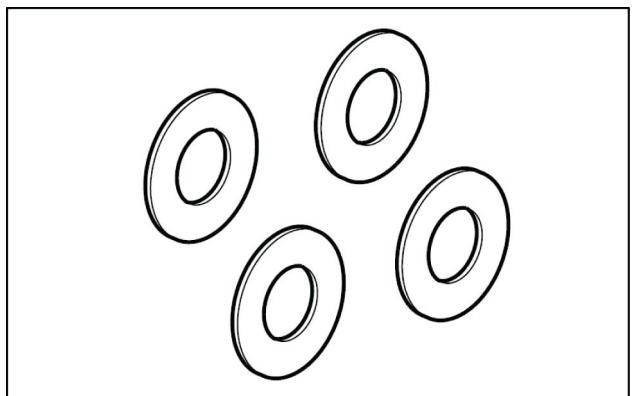

LEL12TLB118AA 176



Mechanical Controls, Four-Wheel Drive (4WD), Power Shuttle, Canopy , B95C TIER 4B (FINAL), Mechanical Controls, Four-Wheel Drive (4WD), Powershift, Cab , B95C TIER 4B (FINAL), Mechanical Controls, Two-Wheel Drive (2WD), Power Shuttle, Cab , B95C TIER 4B (FINAL), Mechanical Controls, Two-Wheel Drive (2WD), Power Shuttle, Canopy , B95C TIER 4B (FINAL), Pilot Controls, Four-Wheel Drive (4WD), Power Shuttle, Cab , B95C TIER 4B (FINAL), Pilot Controls, Four-Wheel Drive (4WD), Power Shuttle, Canopy , B95C TIER 4B (FINAL), Pilot Controls, Four-Wheel Drive (4WD), Powershift, Cab , B95C TIER 4B (FINAL), Pilot Controls, Two-Wheel Drive (2WD), Power Shuttle, Cab , B95C TIER 4B (FINAL), Pilot Controls, Two-Wheel Drive (2WD), Power Shuttle, Canopy

27. Remove the thrust washer (24) and gear (23).

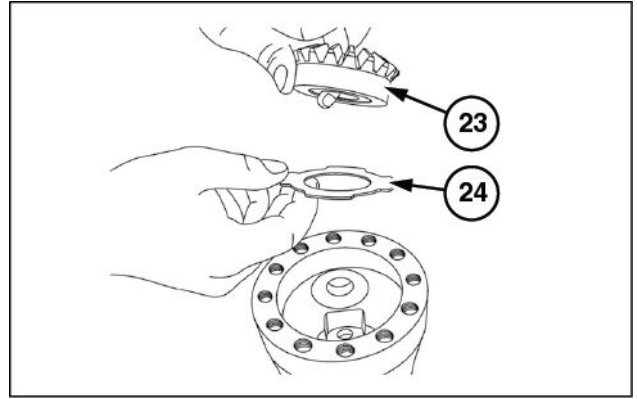

LEL112TLB0632AB 25

11. Remove the ring nut (5) with the tool **380000468**.

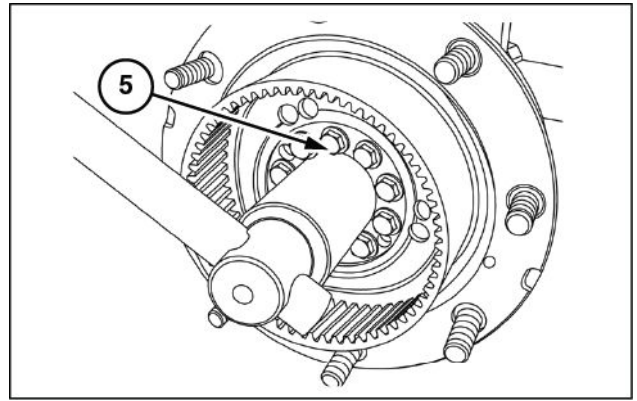

LEL112TLB0225AB 12

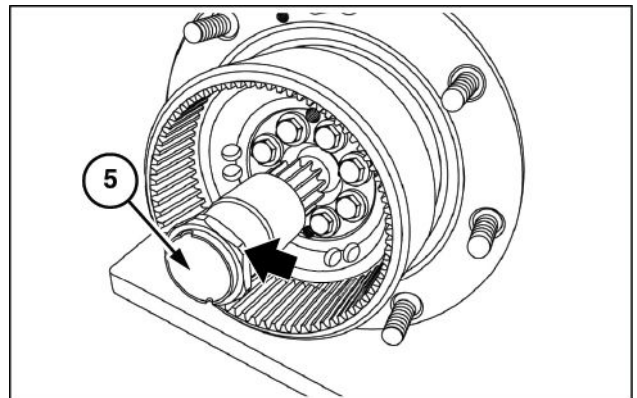

LEL112TLB0226AB 13

12. Remove the bolts (10).

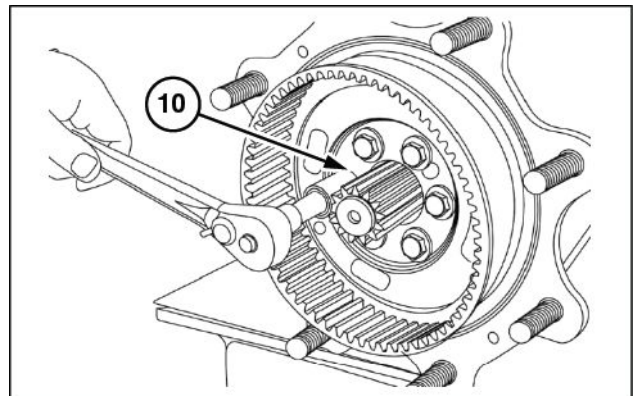

LEL112TLB0227AB 14

13. Install the bolts (10) in the threaded holes in the hub.
14. Install the bolts evenly until the ring gear carrier (11) is free of the swivel housing.

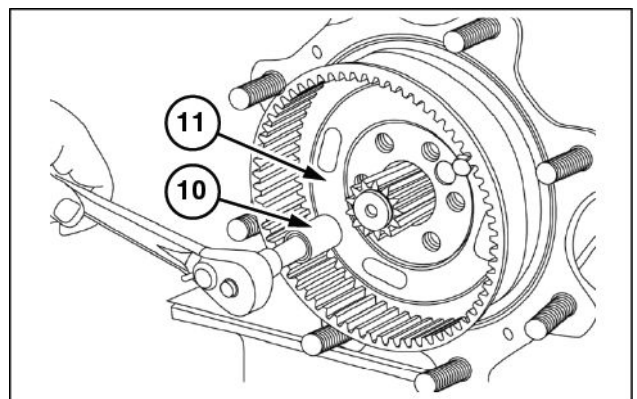

LEL112TLB0228AB 15



PRINTED IN U.S.A.

© 2015 CNH Industrial America LLC.

All rights reserved. No part of the text or illustrations of this publication may be reproduced.

NEW HOLLAND CONSTRUCTION policy is one of continuous improvement and the right to change prices, specification or equipment at any time without notices is reserved.

All data given in this publication is subject to production variations. Dimensions and weight are approximate only and the illustrations do not necessarily show products in standard condition. For exact information about any particular product, please consult your NEW HOLLAND CONSTRUCTION Dealer.

2. Install a new seal ring (5) in the housing (6) with the tool 380200276.

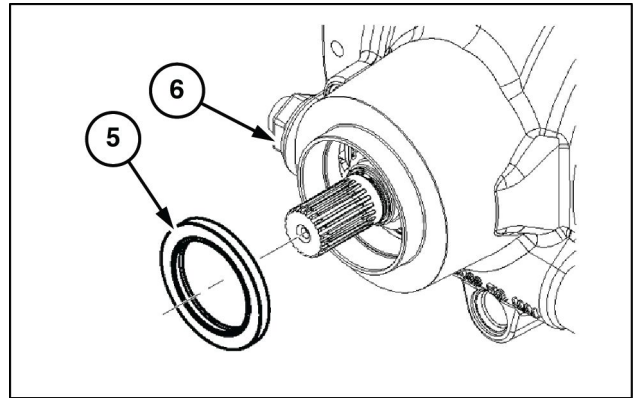

LEL112TLB0984AB 3

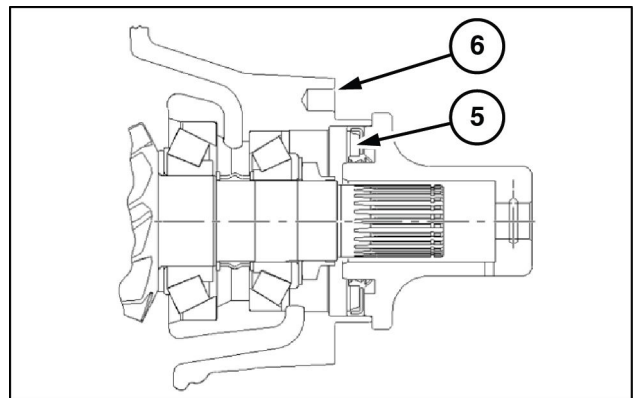

LEL112TLB0987AB 4

3. Apply grease on the O-ring (3).
4. Install the washer (4), O-ring (3) and front flange (2) on the pinion.
5. Install the snap ring (1).

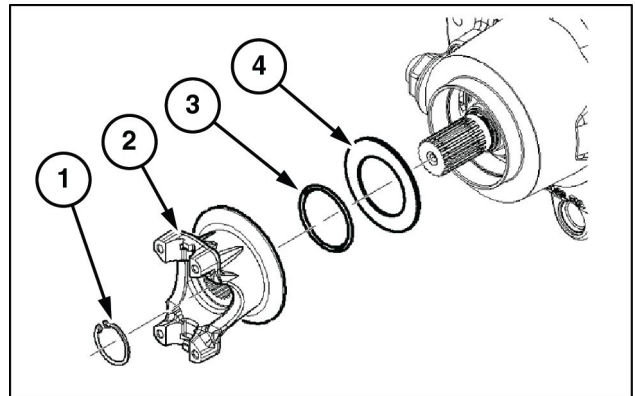

LEL112TLB0983AB 5

Bevel pinion - Disassemble

B110C TIER 4B (FINAL), Mechanical Controls, Four-Wheel Drive (4WD), Power Shuttle, Cab	
B110C TIER 4B (FINAL), Mechanical Controls, Four-Wheel Drive (4WD), Power Shuttle, Canopy	
B110C TIER 4B (FINAL), Mechanical Controls, Four-Wheel Drive (4WD), Powershift, Cab	
B110C TIER 4B (FINAL), Pilot Controls, Four-Wheel Drive (4WD), Power Shuttle, Cab	
B110C TIER 4B (FINAL), Pilot Controls, Four-Wheel Drive (4WD), Power Shuttle, Canopy	
B110C TIER 4B (FINAL), Pilot Controls, Four-Wheel Drive (4WD), Powershift, Cab	
B110C TIER 4B (FINAL), Pilot Controls, Two-Wheel Drive (2WD), Power Shuttle, Cab	

2WS

1. Measure the starting preload F_{P0} of the pinion bearings using a dynamometer whose cord is wound on the end of the pinion shaft.

NOTICE: F_{P0} will be necessary during assembly procedure.

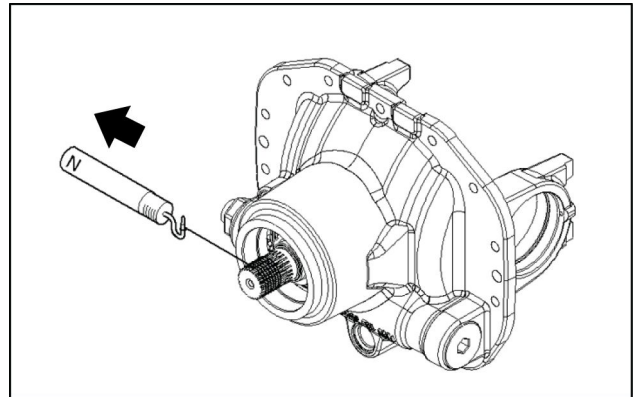

LELI12TLB1436AB 1

2. Measure the rolling torque M_{P0} of the bearings, using a torque wrench and tool **380200269**.

NOTICE: M_{P0} will be necessary during assembly procedure.

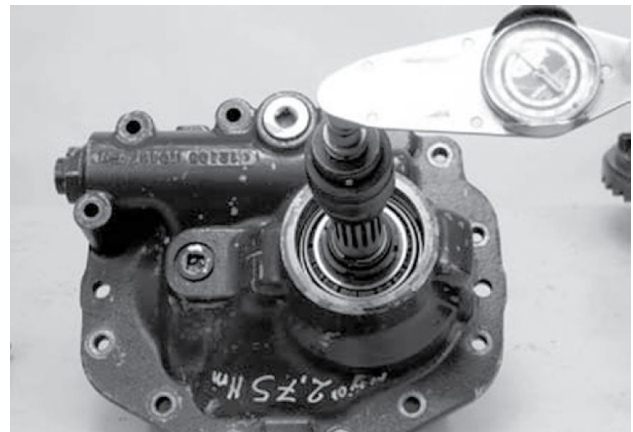

LEPH12TLB1437AA 2

3. Lock the differential assembly in a vice.
4. Remove the ring nut (1) using special tools **380200268** and **380200269**.

NOTE: This operation will damage the ring nut (1) and should be replaced with a new one.

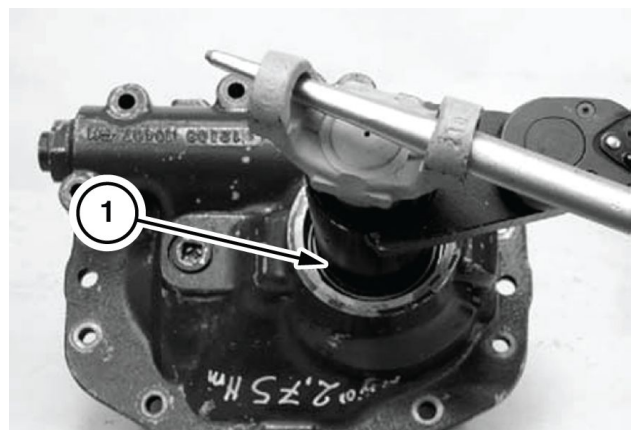

LEPH12TLB1438AB 3

3. Install the relevant ring (23) on the gear (22).

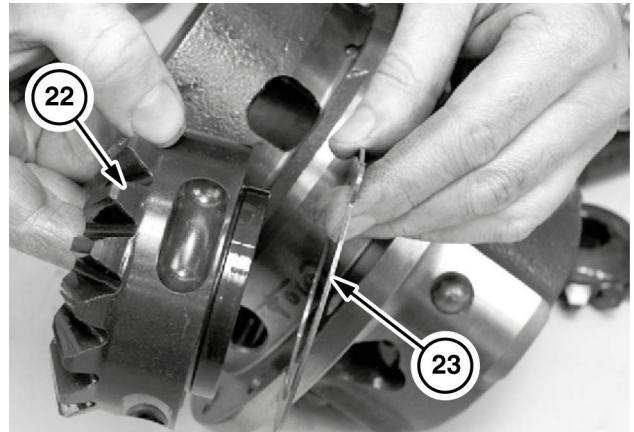

LEPH12TLB1334AB 3

4. Install the gears (20) and relevant shoulder rings (21). Insert the pins (18) just enough to hold the gear in place.

NOTE: Align the flat face of the pins upwards.

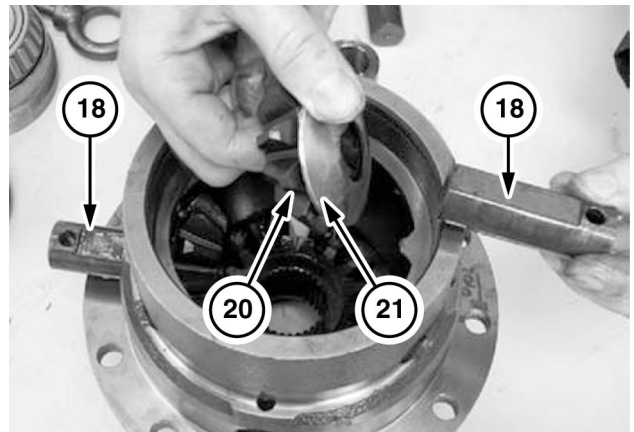

LEPH12TLB1333AB 4

5. Install the spacer (19) with the pins (18). Align the pin holes with those of the differential box (24).

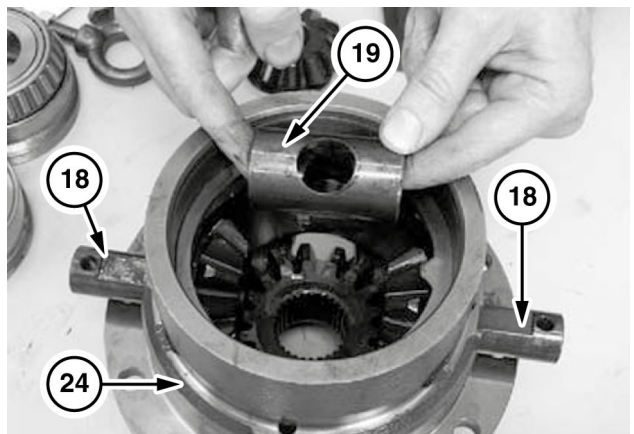

LEPH12TLB1337AB 5

6. Lubricate and install the gear (16) and relevant shoulder ring (17) with the pin (13).

NOTE: Align the flat face of the pin upwards.

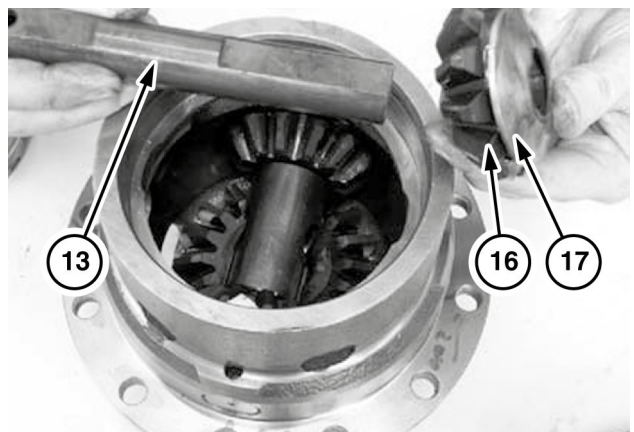

LEPH12TLB1331AB 6

6. Install the springs (4) and (8) and spacer (9).

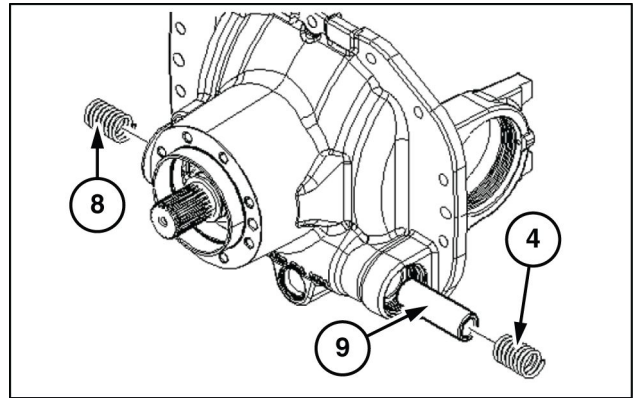

LELI12TLB1382AB 4

7. Install the plug (1) to the prescribed torque of **80 N·m (59 lb ft)**.

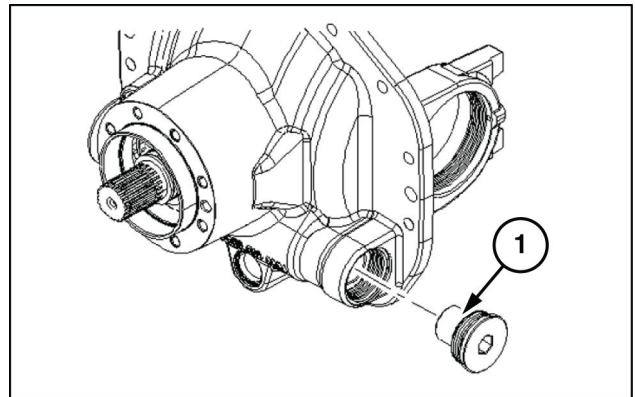

LELI12TLB1387AB 5

8. Install the bushing (6).

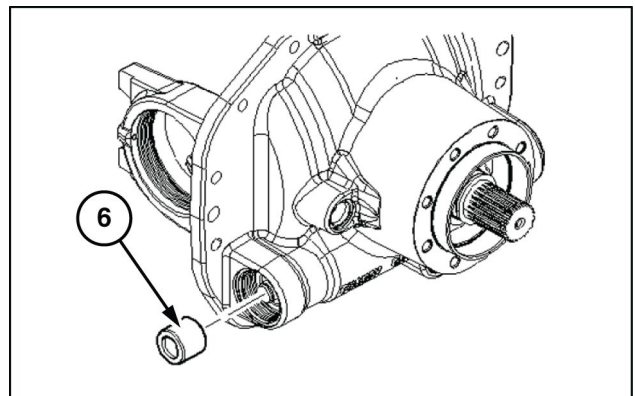

LELI12TLB1388AB 6

9. Install the tool **380200259 (T1)**.

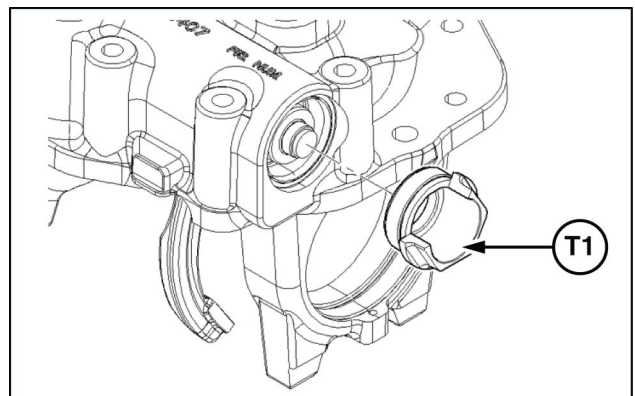

LELI12TLB1389AB 7

Hydraulic service brakes - Dimension

Brake disc dimensions

- A. Brake separator plate (brake piston side) thickness: **7.95 - 8.05 mm (0.313 - 0.317 in)**
- B. Brake friction disc thickness: **6.63 - 6.83 mm (0.261 - 0.269 in)**
- C. Brake separator plate (axle side) thickness: **4.95 - 5.05 mm (0.195 - 0.199 in)**

NOTICE: Replace the brake friction discs when the thickness is less than **5.8 mm (0.23 in)**.

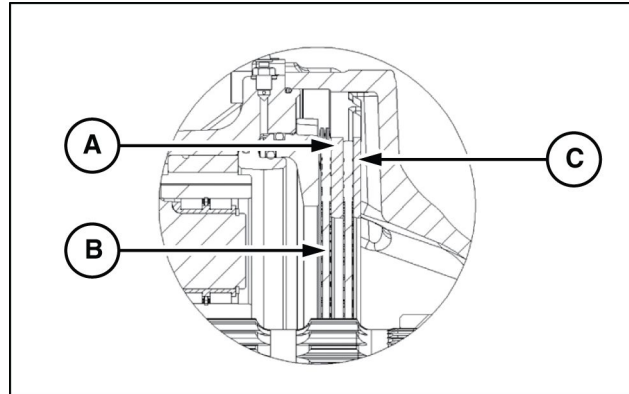

LEL112TLB0141AB 1

Index

Brakes and controls - 33

Hydraulic service brakes - 202

Brake master cylinder - Adjust	28
Brake master cylinder - Dynamic description	7
Brake master cylinder - Install	26
Brake master cylinder - Remove	24
Brakes - Assemble	18
Brakes - Disassemble	12
Hydraulic service brakes - Bleed	9
Hydraulic service brakes - Dimension	4
Hydraulic service brakes - Dynamic description	5
Hydraulic service brakes - Exploded view	6
Hydraulic service brakes - General specification	3
Hydraulic service brakes - Test	10
Hydraulic service brakes - Troubleshooting	29

Parking brake control valve - Assemble

1. Install the bushing (4).

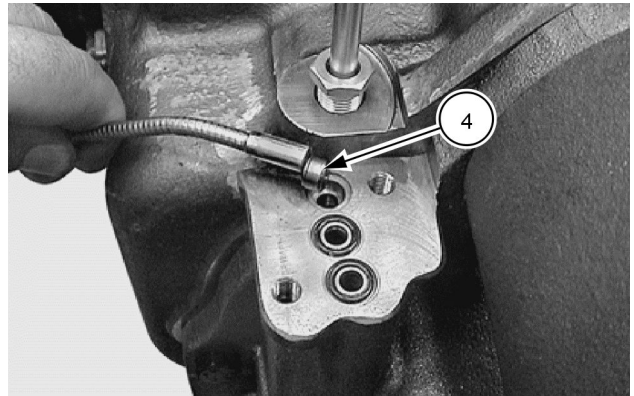

RAIL14TLB0217AA 1

2. Lubricate and install the O-rings (3).

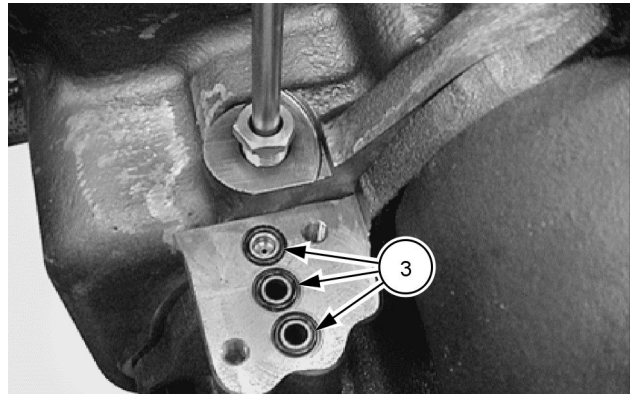

RAIL14TLB0216AA 2

3. Install the solenoid valve (2) with the bolts (1). Torque to **23 N·m (17 lb ft)**.

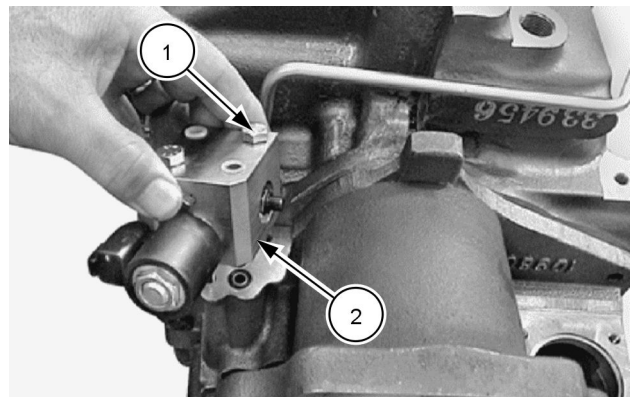

RAIL14TLB0215AA 3

Hydraulic systems - Troubleshooting – Hydraulic pump

Problem	Possible Cause	Correction
Foamy oil	Low oil level	Fill the tank
	Air in the suction system	Check/tighten suction line
	Wrong oil type	Drain and refill with correct oil
Hydraulic oil drain through tank breather	Tank overfilled	Check hydraulic oil level
	Aeration: Air entering the system at: suction tube, pump shaft, fittings or cylinder ring nuts	Make a hydraulic pump performance test
	Cavitation: Restriction of the suction filter in the tank	Make a visual check and/or a hydraulic pump performance test
Oil leaks through the shaft seal	Worn shaft seal	Replace shaft seal and inspect pump
System noisy	Worn or damaged pump gears or pressure plates	Make a hydraulic pump performance test
	Aeration: Air entering the systems at: Suction tube, pump shaft, fittings or cylinder ring nuts	Make a hydraulic pump performance test
	Cavitation: System restrictions in the suction line or in the tank filter	Make a visual check and/or a hydraulic pump performance test
	Water in the system	Visual check
	The system relief valve vibrates	Check system relief valve, adjust/overhaul as necessary
	Vibrations in the lines	Visual check
	Cold hydraulic oil	Check the hydraulic oil operating temperature
	Wrong oil type	Investigate/drain and top up
Oil heating	Low oil quantity	Fill the tank
	Contaminated oil	Drain the tank and refill with clean oil
	Too high/low setting of the relief valve	Drain the tank and refill with clean oil. Test relief valves
	Oil in system too light	Drain the tank and refill with oil with the correct viscosity
	Oil cooler fins obstructed	Clean the oil cooler

Fixed displacement pump - Hydraulic schema

Hydraulic diagram

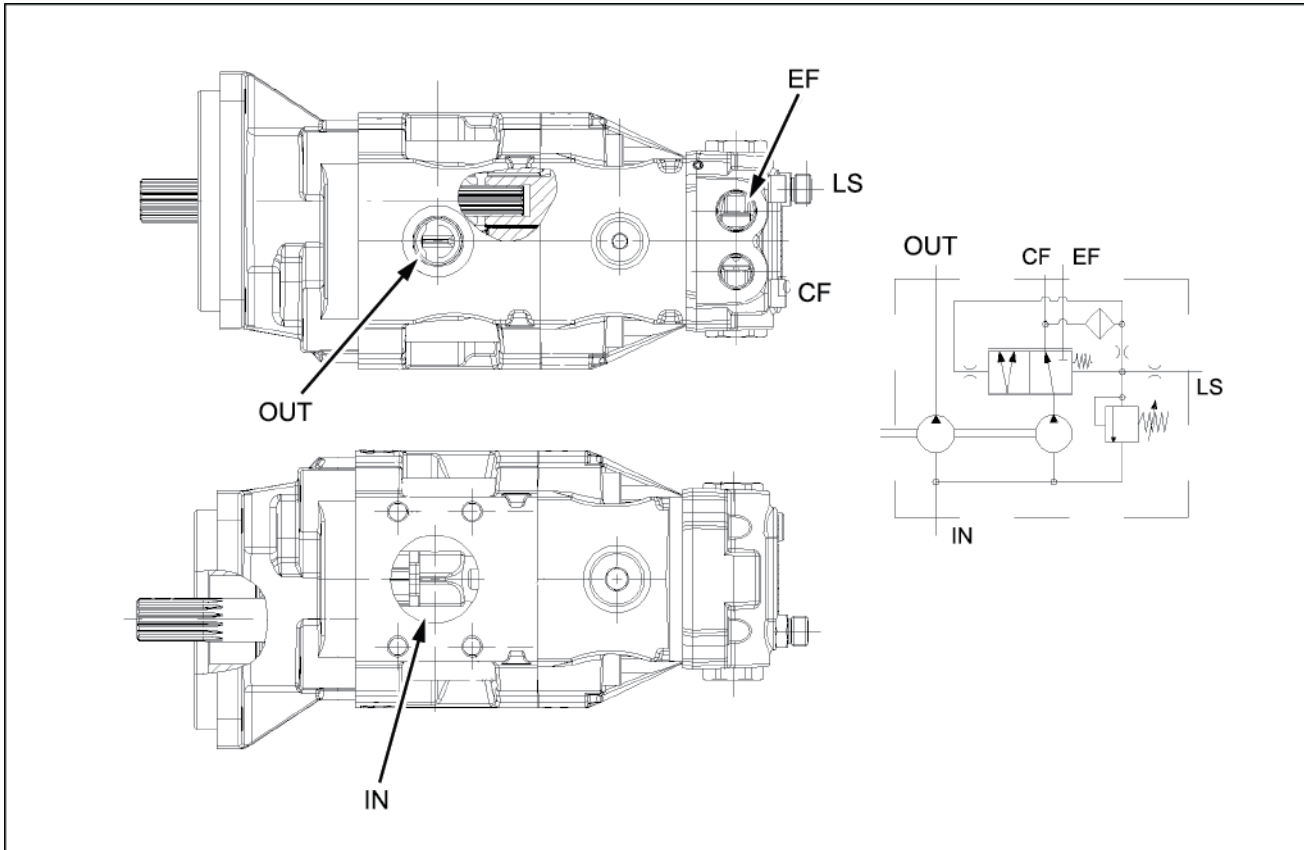

LEL112TLB0683FB 1

Hand control valve - Component identification

Control lever valve

P. Supply

T. Return to tank

Right valve (dipper/bucket)

1. Retracting the dipper
2. Opening the backhoe bucket
3. Extending the dipper
4. Closing the backhoe bucket

Left valve (backhoe attachment/swing)

1. Boom
2. Right swinging
3. Lowering
4. Left swinging

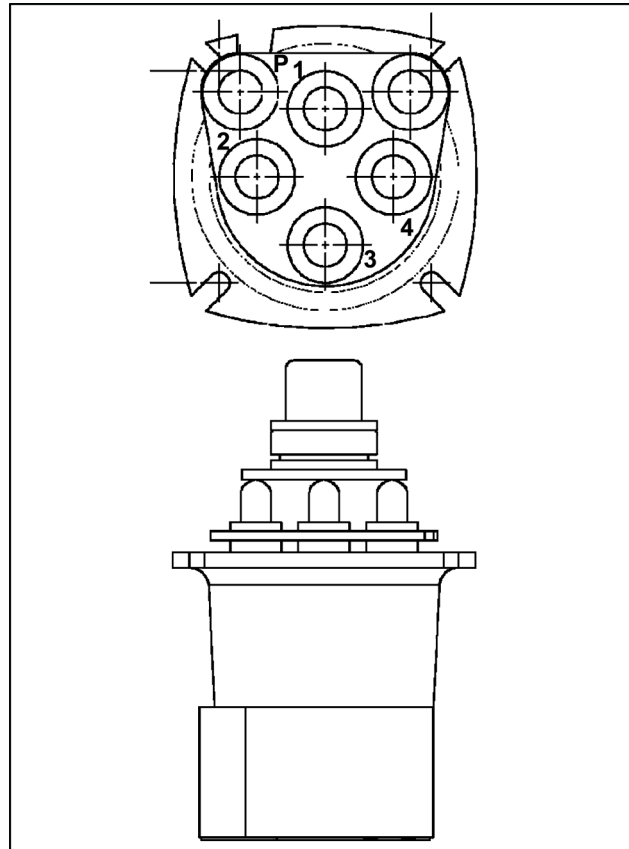

LEL112TLB2310BA 1

Contents

Hydraulic systems - 35

Front loader hydraulic system control - 724

FUNCTIONAL DATA

Front loader hydraulic system control	
Static description – Loader control valve	3
Exploded view – Loader control valve	8

SERVICE

Front loader hydraulic system control	
Replace	9
Disassemble the pilot control valve	10
Assemble the pilot control valve	13

Lift arm cylinder - Disassemble

NOTICE: Cylinder weight: **36 kg (79.37 lb)**. Use a lifting device of adequate capacity.

1. Lift and securely place the cylinder on a workbench.

NOTICE: Be sure that the cylinder is placed horizontally.

2. Drain hydraulic oil from the cylinder.

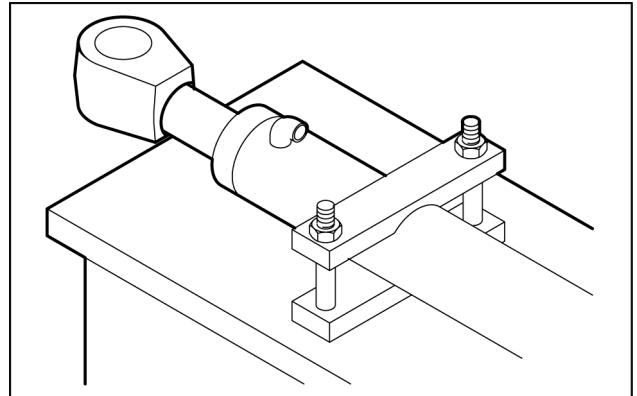

LELI12TLB1691AA 1

3. Support the cylinder rod (1).

4. Remove the bolt (8).

5. Use the wrench **380000725** to loosen the cylinder gland (7).

NOTE: If necessary, gently heat the gland carrier to soften the thread sealant applied during the manufacturing process.

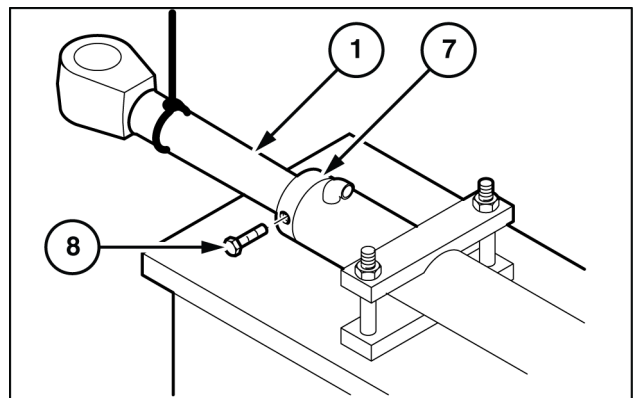

LELI12TLB1694AB 2

6. Remove the cylinder gland (7) from the cylinder barrel (15) using a plastic hammer.

7. Remove the cylinder rod (1) and the cylinder gland (7).

NOTE: Be sure to pull the cylinder rod (1) straight so as not to damage the sliding surfaces.

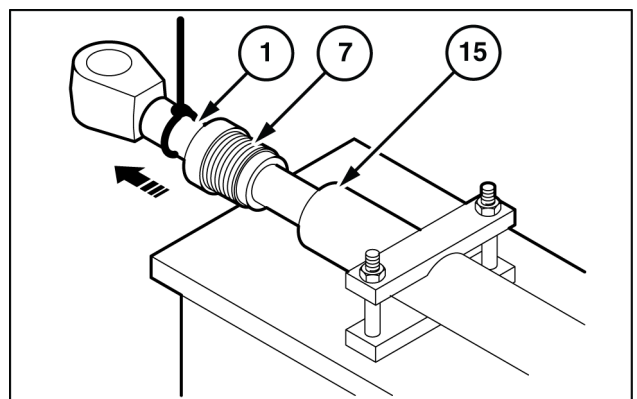

LELI12TLB1695AB 3

8. Remove the bolt (14).

9. Remove the piston (11) and cylinder gland (7) from the cylinder rod (1).

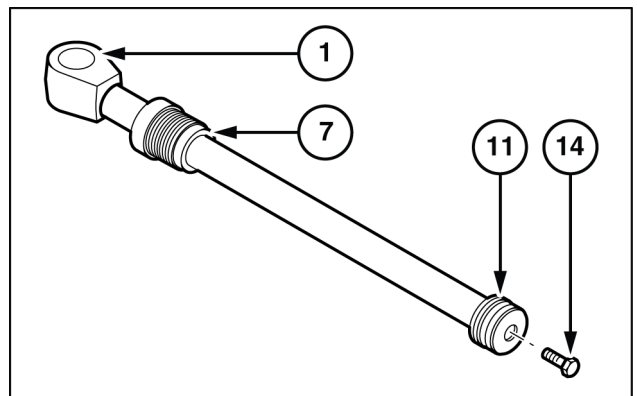

LELI12TLB1696AB 4

Contents

Hydraulic systems - 35

Excavator and backhoe hydraulic controls - 726

FUNCTIONAL DATA

Excavator and backhoe hydraulic controls	
Static description – Backhoe attachment control valve	3
Exploded view – Backhoe attachment control valve	6
Static description	7
Dynamic description	9

SERVICE

Excavator and backhoe hydraulic controls	
Replace the backhoe attachment control valve	12
Disassemble the backhoe attachment control valve (Pilot control valve) (*)	13
Assemble	16
Disassemble the backhoe attachment control valve pilot solenoid valve (*)	18

(*) See content for specific models

Boom cylinder - Disassemble

NOTICE: Cylinder weight (with short dipper): **80.5 kg (177.47 lb)**. Use a lifting device of adequate capacity.

NOTICE: Cylinder weight (with long dipper): **93.1 kg (205.25 lb)**. Use a lifting device of adequate capacity.

1. Lift and securely place the cylinder on a workbench.

NOTE: Be sure that the cylinder is placed horizontally.

2. Drain hydraulic oil from the cylinder.

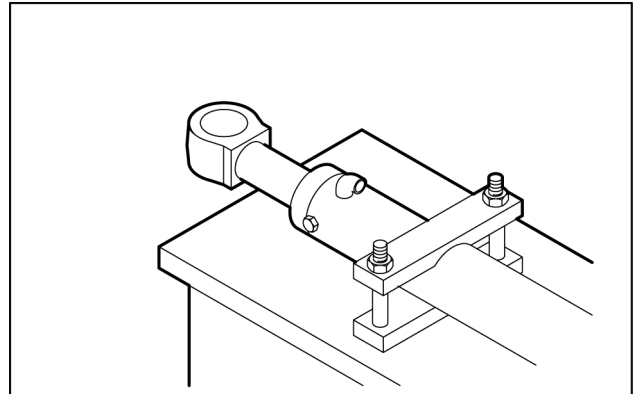

LELI12TLB1894AA 1

3. Support the cylinder rod (3).

4. Remove the bolt (8).

5. Use the wrench **380000724** to loosen the cylinder gland (9).

NOTICE: If necessary gently heat the gland carrier to soften the thread sealant applied during manufacture.

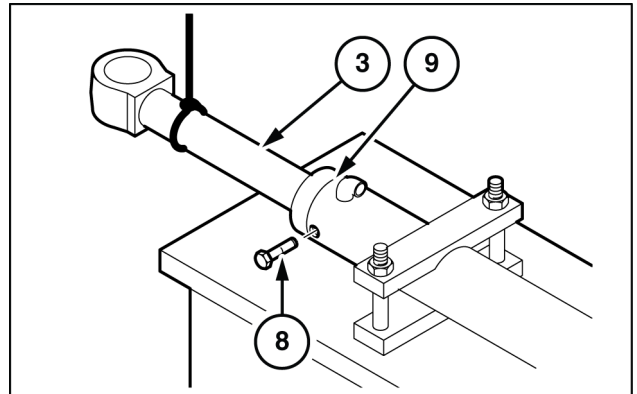

LELI12TLB1895AB 2

6. Remove the cylinder gland (9) from the cylinder barrel (16) with a plastic hammer.

7. Remove the cylinder rod (3) and the cylinder gland (9).

NOTICE: Be sure to pull the cylinder rod (3) straight so as not to damage the sliding surfaces.

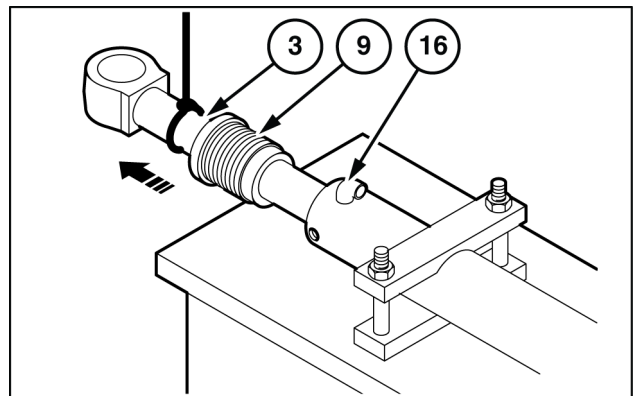

LELI12TLB1896AB 3

Contents

Hydraulic systems - 35

Swing arm hydraulic system - 739

TECHNICAL DATA

Swing cylinder	
Dimension	3

FUNCTIONAL DATA

Swing cylinder	
Exploded view	4

SERVICE

Swing cylinder	
Remove	5
Disassemble	6

Index

Hydraulic systems - 35

Telescopic arm hydraulic system - 740

Telescopic arm cylinder - Dimension	3
Telescopic arm cylinder - Disassemble	6
Telescopic arm cylinder - Exploded view	4
Telescopic arm cylinder - Remove	5

Contents

Steering - 41

Steering control - 101

FUNCTIONAL DATA

Steering control

Static description	3
Component localization	4
Dynamic description	5



Mechanical Controls, Four-Wheel Drive (4WD), Power Shuttle, Canopy , B95C TIER 4B (FINAL), Mechanical Controls, Four-Wheel Drive (4WD), Powershift, Cab , B95C TIER 4B (FINAL), Mechanical Controls, Two-Wheel Drive (2WD), Power Shuttle, Cab , B95C TIER 4B (FINAL), Mechanical Controls, Two-Wheel Drive (2WD), Power Shuttle, Canopy , B95C TIER 4B (FINAL), Pilot Controls, Four-Wheel Drive (4WD), Power Shuttle, Cab , B95C TIER 4B (FINAL), Pilot Controls, Four-Wheel Drive (4WD), Power Shuttle, Canopy , B95C TIER 4B (FINAL), Pilot Controls, Four-Wheel Drive (4WD), Powershift, Cab , B95C TIER 4B (FINAL), Pilot Controls, Two-Wheel Drive (2WD), Power Shuttle, Cab , B95C TIER 4B (FINAL), Pilot Controls, Two-Wheel Drive (2WD), Power Shuttle, Canopy

Inflating procedure

1. Move the machine to a level and firm ground.
2. Lower the loader attachment to the ground.
3. Place the backhoe attachment in the road travel position.
4. Place the direction-of-travel lever and gearshift lever in neutral position.
5. Immobilize the machine by means of the parking brake.
6. Stop the engine and remove the starter switch key.
7. Insert the self-locking spout of the inflating device **(1)** into the tire valve.
8. The inflating device is equipped with a pressure gauge **(2)** which enables, as soon as it is connected, to check the pressure value.
9. If pressure is lower than the recommended pressure, inflate.

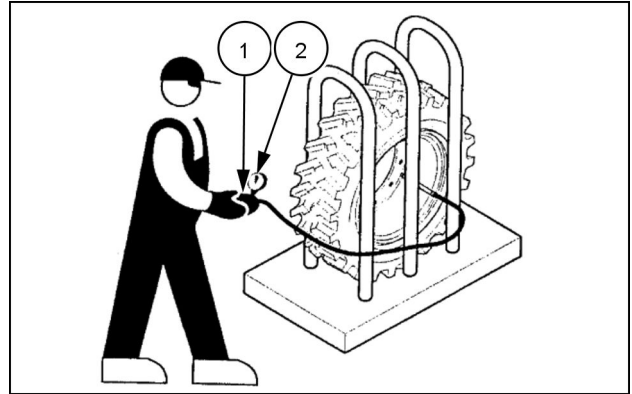

LEEN11T0372AA 2

Contents

Cab climate control - 50

Ventilation - 104

FUNCTIONAL DATA

Air filter	
Static description	3

SERVICE

Air filter	
Service instruction	4
Service instruction	5

Receiver/Dryer - Static description

The receiver/dryer (1) stores the liquid coolant to make sure that a steady flow to the expansion valve is maintained also under extremely different operating conditions.

The drier contains a desiccant (molecular sieve) which absorbs any moisture within the system, and a filter which prevents the entry of foreign particles.

NOTE: Any moisture in the air conditioning system is extremely harmful. Moisture not absorbed by the dehydrator will circulate with the coolant and droplets may collect and freeze in the thermostatic expansion valve orifice. This action will block the coolant flow and stop the cooling action. Moisture will also react with coolant **HFC R134A** and the lubricant to form a corrosive acid.

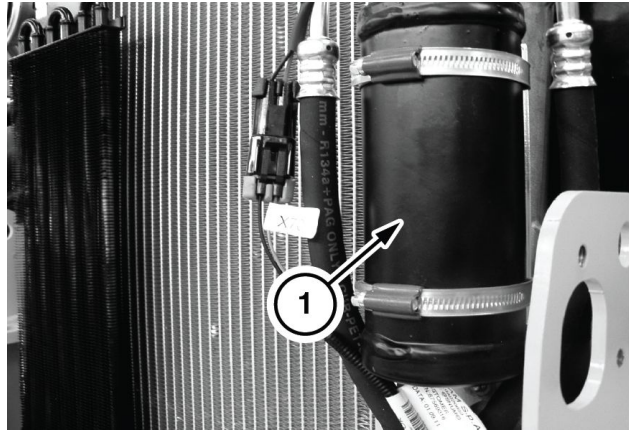

LEPH12TLB1970AB 1

The desiccant can only absorb a limited amount of moisture before reaching saturation point. Because of this, after any system component replacement or repairs requiring entry into the system, the receiver/dryer should be replaced.

CLICK HERE TO **DOWNLOAD** THE COMPLETE MANUAL

- Thank you very much for reading the preview of the manual.
- You can download the complete manual from: www.heydownloads.com by clicking the link below



- Please note: If there is no response to CLICKING the link, please download this PDF first and then click on it.

CLICK HERE TO **DOWNLOAD** THE COMPLETE MANUAL

Performance test example 10

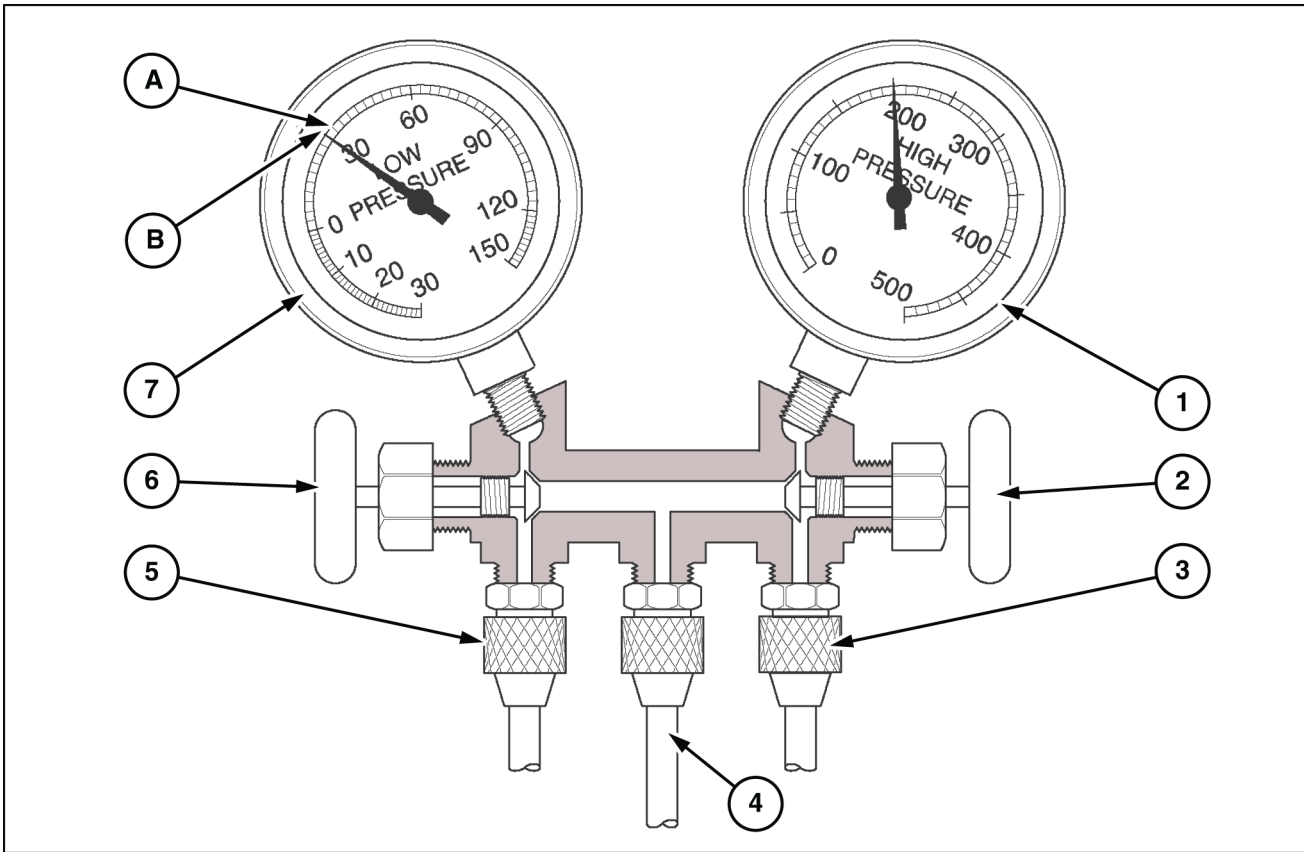

LELI12TLB2164FB 10

5. Check the clearance between the plate (4) and the rotor (8). This should be consistent around the circumference and be between **0.4 - 0.8 mm (0.016 - 0.031 in)**.

NOTE: If the air gap is not consistent, lightly pry up on the counter weighted front plate at the low spots or lightly tap down at the high spots.

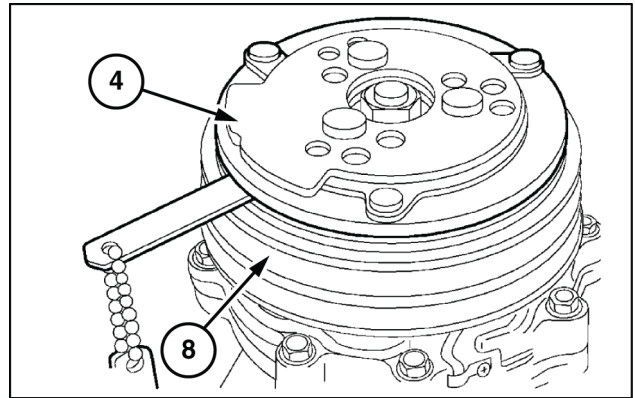

LELI12TLB2198AB 5

6. If the clearance is not within specification, the shims (5) under the front plate should be added or removed, until the correct clearance is obtained.

NOTE: New shims are available in the following sizes: **1 mm (0.039 in)**, **0.5 mm (0.020 in)** and **0.125 mm (0.005 in)**.

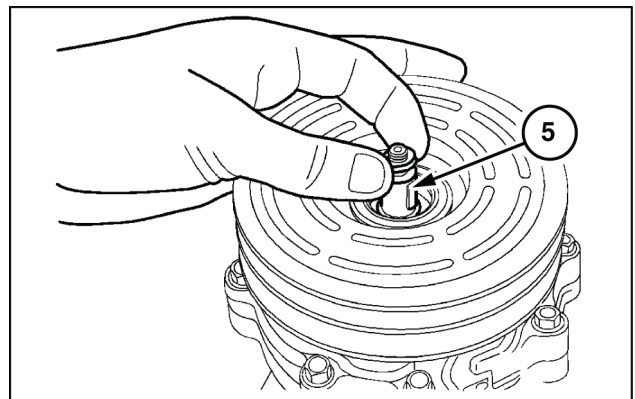

LELI12TLB2199AB 6

7. Install the dust cover (2). Install the bolts (1) (if applicable).

Prevention of common electrical problems

In order to prevent common problems and to achieve a higher reliability, please follow the below procedures. Please use harness diagnostic and repair kit, part number **380040185**, to assist you with repairs to wires, harnesses, and connectors.

Sealed connectors

Sealed connectors are designed with weather-proof seals that protect the connector's terminals from moisture and debris. This protection makes them ideal for use on the exterior. Two types of seals are available in these types of connectors:

- A connector seal which provides an environmental seal between the mating connectors.
- A cable seal which seals the area where each wire enters the connector.

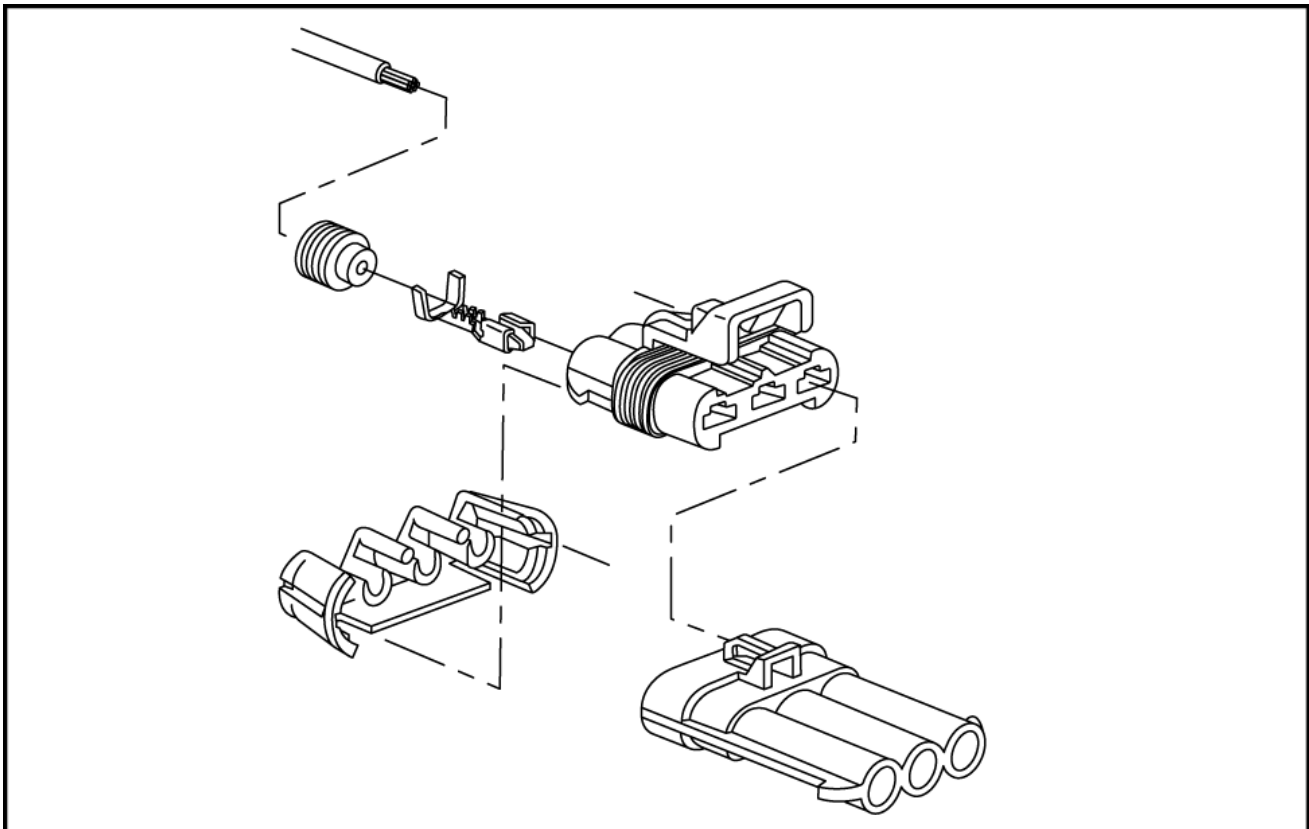

RAIL14SSL0609AA 20

NAME	DESCRIPTION
X14	Anti theft unit
X15.2	Starter switch connector
X17	Seat microswitch (optional)
X34	KM sensor connector
X55	12 V socket
X80	Beacon lamp connector
X81	Beacon lamp connector
X100	"Carraro" harness solenoid valve connector
X111	"Carraro" harness RPM sender connector
X112	A/C fuse connector
X128	Optional
X131	Flasher unit connector
X142	Guide ride control lamp connector
X144	Switch block light connector
X222	Differential block light connector
X448	Minifuse connector
X462	Engine control unit connector
X463	WIF connector
X466	Glow control unit fuse connector
X468	Lambda sensor connector
X469	Glow control unit connector
X470	Connect to engine harness
X471	Electric valves connector
X473	A/C clutch connector
X474	Air temperature sensor connector
X475	Differential. pressure sensor connector
X476	Gas temperature sensor 1 connector
X477	Gas temperature sensor 2 connector
X496	Front harness - engine harness interface connector
X800	Front harness - engine harness interface connector
X805	Ride control pressure switch connector
X810	Telematics connector
Y12	4X1 bucket proportional solenoid valves
Y34	Ride control solenoid valve
Y35	Hand hammer solenoid valve
Y100	Forward travel solenoid valve
Y101	Reverse travel solenoid valve
Y102	PWM 1/3 solenoid valve
Y103	PWM 2/4 solenoid valve
Y104	Solenoid valve S13
Y105	Solenoid valve S24
Y113	4WD solenoid
Y114	Differential lock solenoid valve
Y202	Backhoe attachment travel solenoid valve
Y203	Backhoe attachment lock solenoid valve
Y206	Bucket level solenoid valve
Y207	Delivery doubling solenoid valve
Y209	Backhoe attachment hand hammer solenoid valve
Y212	Parking brake solenoid valve
X1	General line - engine line interface connector
X5	Fuel level sensor connector
X7	Reverse travel alarm connector
X9	General line - front instrument panel line interface connector
X10	General line - solenoid valve line interface connector

Wiring harnesses - Electrical schematic sheet 10 – Drives

B110C TIER 4B (FINAL), Mechanical Controls, Four-Wheel Drive (4WD), Powershift, Cab	
B110C TIER 4B (FINAL), Pilot Controls, Four-Wheel Drive (4WD), Powershift, Cab	
B95C TC TIER 4B (FINAL), Pilot Controls, Four-Wheel Drive (4WD), Powershift, Cab	
B95C TIER 4B (FINAL), Mechanical Controls, Four-Wheel Drive (4WD), Powershift, Cab	
B95C TIER 4B (FINAL), Pilot Controls, Four-Wheel Drive (4WD), Powershift, Cab	

Wiring harnesses - Electrical schematic sheet 23 – Dashboard - Left side harness

B110C TIER 4B (FINAL), Mechanical Controls, Four-Wheel Drive (4WD), Powershift, Cab	
B110C TIER 4B (FINAL), Pilot Controls, Four-Wheel Drive (4WD), Powershift, Cab	
B95C TC TIER 4B (FINAL), Pilot Controls, Four-Wheel Drive (4WD), Powershift, Cab	
B95C TIER 4B (FINAL), Mechanical Controls, Four-Wheel Drive (4WD), Powershift, Cab	
B95C TIER 4B (FINAL), Pilot Controls, Four-Wheel Drive (4WD), Powershift, Cab	

Wiring harnesses - Electrical schematic sheet 06 – Denox -ECU - Supply module

B110C TIER 4B (FINAL), Mechanical Controls, Four-Wheel Drive (4WD), Power Shuttle, Cab	
B110C TIER 4B (FINAL), Pilot Controls, Four-Wheel Drive (4WD), Power Shuttle, Cab	
B110C TIER 4B (FINAL), Pilot Controls, Two-Wheel Drive (2WD), Power Shuttle, Cab	
B95C TC TIER 4B (FINAL), Mechanical Controls, Four-Wheel Drive (4WD), Power Shuttle, Cab	
B95C TIER 4B (FINAL), Mechanical Controls, Four-Wheel Drive (4WD), Power Shuttle, Cab	
B95C TIER 4B (FINAL), Mechanical Controls, Two-Wheel Drive (2WD), Power Shuttle, Cab	
B95C TIER 4B (FINAL), Pilot Controls, Four-Wheel Drive (4WD), Power Shuttle, Cab	
B95C TIER 4B (FINAL), Pilot Controls, Two-Wheel Drive (2WD), Power Shuttle, Cab	

Wiring harnesses - Electrical schematic sheet 19 – Radio - Power point

B110C TIER 4B (FINAL), Mechanical Controls, Four-Wheel Drive (4WD), Power Shuttle, Cab	
B110C TIER 4B (FINAL), Pilot Controls, Four-Wheel Drive (4WD), Power Shuttle, Cab	
B110C TIER 4B (FINAL), Pilot Controls, Two-Wheel Drive (2WD), Power Shuttle, Cab	
B95C TC TIER 4B (FINAL), Mechanical Controls, Four-Wheel Drive (4WD), Power Shuttle, Cab	
B95C TIER 4B (FINAL), Mechanical Controls, Four-Wheel Drive (4WD), Power Shuttle, Cab	
B95C TIER 4B (FINAL), Mechanical Controls, Two-Wheel Drive (2WD), Power Shuttle, Cab	
B95C TIER 4B (FINAL), Pilot Controls, Four-Wheel Drive (4WD), Power Shuttle, Cab	
B95C TIER 4B (FINAL), Pilot Controls, Two-Wheel Drive (2WD), Power Shuttle, Cab	

Wiring harnesses - Electrical schematic sheet 02 – Power distribution - Charging system

B110C TIER 4B (FINAL), Mechanical Controls, Four-Wheel Drive (4WD), Power Shuttle, Canopy	
B110C TIER 4B (FINAL), Pilot Controls, Four-Wheel Drive (4WD), Power Shuttle, Canopy	
B95C TC TIER 4B (FINAL), Mechanical Controls, Four-Wheel Drive (4WD), Power Shuttle, Canopy	---
B95C TC TIER 4B (FINAL), Pilot Controls, Four-Wheel Drive (4WD), Power Shuttle, Canopy	
B95C TIER 4B (FINAL), Mechanical Controls, Four-Wheel Drive (4WD), Power Shuttle, Canopy	
B95C TIER 4B (FINAL), Mechanical Controls, Two-Wheel Drive (2WD), Power Shuttle, Canopy	
B95C TIER 4B (FINAL), Pilot Controls, Four-Wheel Drive (4WD), Power Shuttle, Canopy	
B95C TIER 4B (FINAL), Pilot Controls, Two-Wheel Drive (2WD), Power Shuttle, Canopy	

Wiring harnesses - Electrical schematic sheet 17 – Parking brake system

B110C TIER 4B (FINAL), Mechanical Controls, Four-Wheel Drive (4WD), Power Shuttle, Canopy	
B110C TIER 4B (FINAL), Pilot Controls, Four-Wheel Drive (4WD), Power Shuttle, Canopy	
B95C TC TIER 4B (FINAL), Mechanical Controls, Four-Wheel Drive (4WD), Power Shuttle, Canopy	---
B95C TC TIER 4B (FINAL), Pilot Controls, Four-Wheel Drive (4WD), Power Shuttle, Canopy	
B95C TIER 4B (FINAL), Mechanical Controls, Four-Wheel Drive (4WD), Power Shuttle, Canopy	
B95C TIER 4B (FINAL), Mechanical Controls, Two-Wheel Drive (2WD), Power Shuttle, Canopy	
B95C TIER 4B (FINAL), Pilot Controls, Four-Wheel Drive (4WD), Power Shuttle, Canopy	
B95C TIER 4B (FINAL), Pilot Controls, Two-Wheel Drive (2WD), Power Shuttle, Canopy	

Wiring harnesses - Electrical schematic sheet 30 – Telematics

B110C TIER 4B (FINAL), Mechanical Controls, Four-Wheel Drive (4WD), Power Shuttle, Canopy	
B110C TIER 4B (FINAL), Pilot Controls, Four-Wheel Drive (4WD), Power Shuttle, Canopy	
B95C TC TIER 4B (FINAL), Mechanical Controls, Four-Wheel Drive (4WD), Power Shuttle, Canopy	---
B95C TC TIER 4B (FINAL), Pilot Controls, Four-Wheel Drive (4WD), Power Shuttle, Canopy	
B95C TIER 4B (FINAL), Mechanical Controls, Four-Wheel Drive (4WD), Power Shuttle, Canopy	
B95C TIER 4B (FINAL), Mechanical Controls, Two-Wheel Drive (2WD), Power Shuttle, Canopy	
B95C TIER 4B (FINAL), Pilot Controls, Four-Wheel Drive (4WD), Power Shuttle, Canopy	
B95C TIER 4B (FINAL), Pilot Controls, Two-Wheel Drive (2WD), Power Shuttle, Canopy	

CONNECTOR X404.S - TRAX HARNESS - FRONT PANEL INTERFACE

- Powershift

CONNECTOR X404.S - TRAX HARNESS - FRONT PANEL INTERFACE			
PIN NUMBER	WIRE NUMBER	CIRCUIT REFERENCE	ELECTRICAL SCHEMATIC FRAME
1	TR-8370 (WH-RD) TR-8371 (WH-RD)	+15 POWER +15 POWER	26
3	TR-8010 (BL-RD)	DECLUTCH	26
4	TR-8020 (BR-GN)	4WD	26
5	TR-8070 (LB-WH)	W ALTERNATOR. SIGNAL	26
6	TR-8320 (BR-BK) TR-8323 (BR-BK)	FORWARD MOTION FORWARD MOTION	26
7	TR-1950 (BR-WH) TR-8311 (BR-WH)	REVERSE REVERSE	26
8	TR-8030 (VT/BK)	AUTO-MANUAL	26
9	TR-8000 (RD)	+30 POWER	26
10	TR-8060 (VT-WH)	DIFF. LOCK SIGNAL	26
12	TR-8040 (GY-BL)	SPEED SENSOR OUT	26
13	TR-8050 (RD-BK)	STOP SWITCH OUT	26

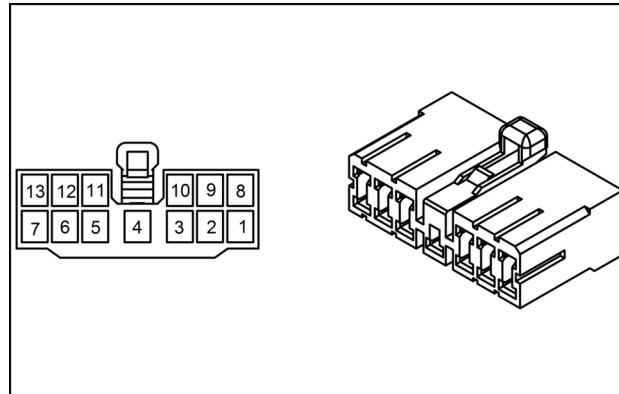

47564753 11

CONNECTOR X-025 - FOOT THROTTLE

CONNECTOR X-025 - FOOT THROTTLE			
PIN NUMBER	WIRE NUMBER	CIRCUIT REFERENCE	ELECTRICAL SCHEMATIC FRAME
1	G222 (BK)	GROUND	15
2	-	-	
3	1650 (YE)	FOOT THROTTLE SIGNAL	15
4	1660 (YE)	FOOT THROTTLE SWITCH	15
5	1670 (PK)	FOOT THROTTLE B+	15
6	1680 (BL)	IDLE VALIDATION	15

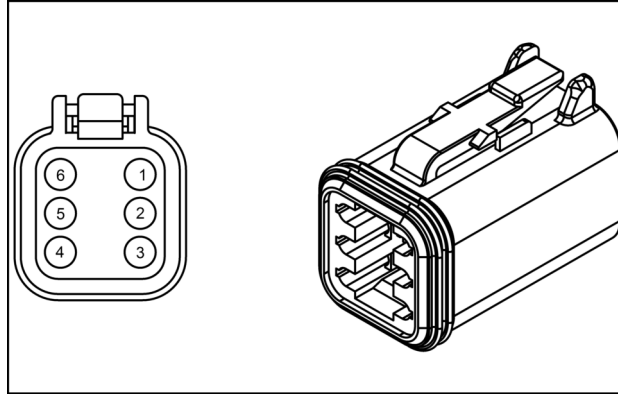

87597749 4

Wire connectors - Component diagram 22

CONNECTOR X-220 - A/C

CONNECTOR X-220 - A/C			
PIN NUMBER	WIRE NUMBER	CIRCUIT REFERENCE	ELECTRICAL SCHEMATIC FRAME
1	4030 (YE)	A/C 1ST SPEED	18
2	4040 (YE)	A/C 2ND SPEED	18
3	4050 (YE)	A/C 3RD SPEED	18
4	4062 (OR)	+15 A/C SUPPLY	18
5	4070 (YE)	A/C FROM POTENTIOMETER	18
6	4080 (YE)	A/C FROM POTENTIOMETER	18
7	4090 (YE)	A/C FROM POTENTIOMETER	18
8	4100 (YE)	A/C FROM POTENTIOMETER	18
9	4110 (YE)	A/C FROM POTENTIOMETER	18
10	G243 (BK)	GROUND	18
11	1351 (YE)	A/C HIGH PRESSURE SWITCH FAULT	18

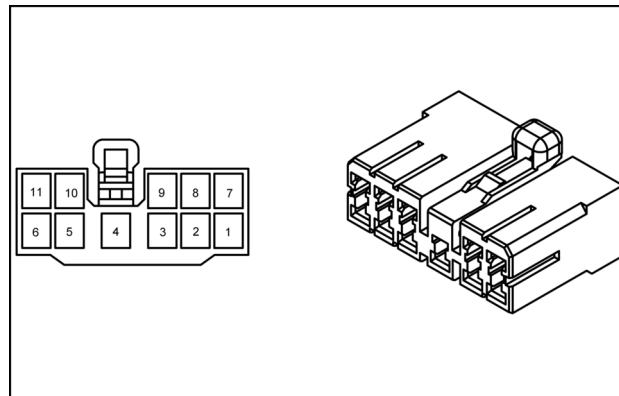

47373520 1

CONNECTOR X-463 - WATER IN FUEL SWITCH

CONNECTOR X-463 - WATER IN FUEL SWITCH			
PIN NUMBER	WIRE NUMBER	CIRCUIT REFERENCE	ELECTRICAL SCHEMATIC FRAME
1	E300 (YE)	WATER IN FUEL LEVEL SENSOR SIGNAL	7
2	G015 (BK)	BATTERY MINUS 4	7
3	1504 (OR)	TERMINAL 15 SW BATT+	7

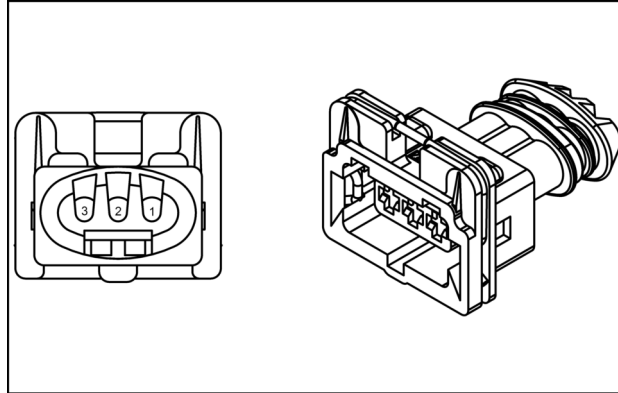

87709663 4

Wire connectors - Component diagram 61

CONNECTOR X-611 - SCR TANK HEAT VLV

CONNECTOR X-611 - SCR TANK HEAT VLV			
PIN NUMBER	WIRE NUMBER	CIRCUIT REFERENCE	ELECTRICAL SCHEMATIC FRAME
1	IGN10 (OR)	IGN TO SCR TANK HEATING VALVE	6
2	-	-	
3	E070 (YE)		6

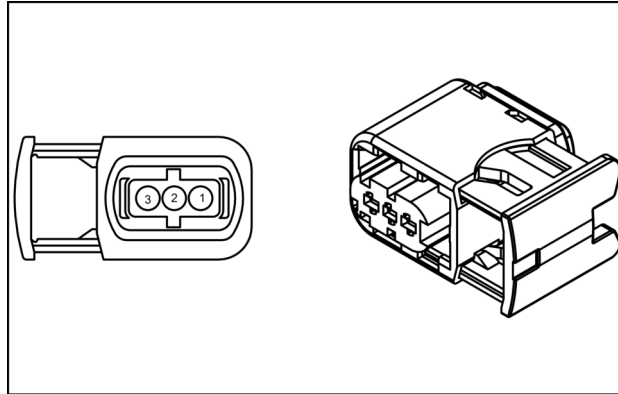

84146685 1

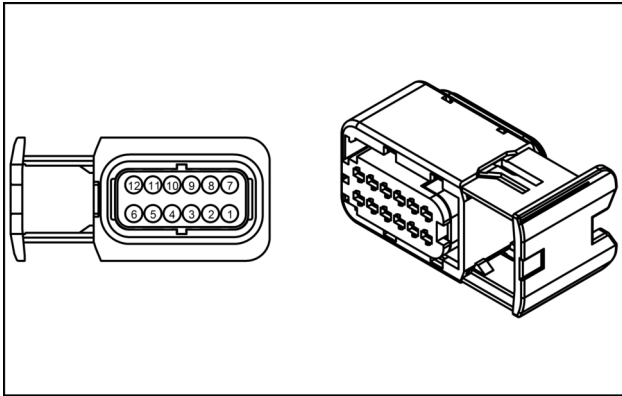

84152570 1

Connector X-9122 - Engine Control Unit (ECU) connector K

Over 56kW (76hp) engines

CONNECTOR X-9122 - ECU connector K			
PIN NUMBER	WIRE NUMBER	CIRCUIT REFERENCE	ELECTRICAL SCHEMATIC FRAME
K01	VE-9017	Main relay switched fused supply, independent source	SHEET 04
K02	VE-9158	Ground, Battery minus (negative) terminal	
K03	VE-9141	Main relay switched fused supply, shared source (K05)	
K04	VE-9159	Ground, Battery minus (negative) terminal	
K05	VE-9142	Main relay switched fused supply, shared source (K03)	
K06	VE-9160	Ground, Battery minus (negative) terminal	
K07	VE-9161	Low Side Driver (LSD), Diesel Exhaust Fluid (DEF)/AdBlue® tank heating valve	
K08	VE-9048	Input signal, Key switch start position	
K09	-	-	
K10	-	-	
K11	-	-	
K12	-	-	
K13	-	-	
K14	-	-	
K15	-	-	
K16	-	-	
K17	-	-	
K18	VE-9143	+5 V sensor supply, Exhaust manifold pressure sensor	SHEET 04
K19	VE-9144	Input signal, Intake air temperature sensor	
K20	VE-9162	Reference ground, Intake air temperature sensor	
K21	-	-	
K22	VE-9073	Input signal, Glow-plug Control Unit (GCU) feedback	SHEET 04
K23	VE-9150	CAN 2 High, Selective Catalytic Reduction (SCR) devices	
K24	VE-9068	CAN 1 High, Diagnostic and maintenance connector	
K25	VE-9067	CAN 1 Low, Diagnostic and maintenance connector	
K26	VE-9072	Low Side Driver (LSD), GCU relay	
K27	VE-9056	Low Side Driver (LSD), Starter control relay	
K28	VE-9018	Low Side Driver (LSD), Main relay	
K29	-	-	
K30	VE-9077	Input signal, Water in fuel switch	SHEET 04
K31	-	-	
K32	-	-	
K33	-	-	
K34	-	-	
K35	-	-	
K36	-	-	

Contents

Electrical systems - 55

Engine starting system - 201

TECHNICAL DATA

Engine starter	
General specification	3

FUNCTIONAL DATA

Engine starting system	
Dynamic description	4
Engine starter	
Component localization	5

SERVICE

Engine starting system	
Service instruction Troubleshooting	8
Engine starter	
Check	10
Remove	13
Check	14

DIAGNOSTIC

Engine starter	
Troubleshooting – Starter motor	16



Mechanical Controls, Four-Wheel Drive (4WD), Power Shuttle, Canopy , B95C TIER 4B (FINAL), Mechanical Controls, Four-Wheel Drive (4WD), Powershift, Cab , B95C TIER 4B (FINAL), Mechanical Controls, Two-Wheel Drive (2WD), Power Shuttle, Cab , B95C TIER 4B (FINAL), Mechanical Controls, Two-Wheel Drive (2WD), Power Shuttle, Canopy , B95C TIER 4B (FINAL), Pilot Controls, Four-Wheel Drive (4WD), Power Shuttle, Cab , B95C TIER 4B (FINAL), Pilot Controls, Four-Wheel Drive (4WD), Power Shuttle, Canopy , B95C TIER 4B (FINAL), Pilot Controls, Four-Wheel Drive (4WD), Powershift, Cab , B95C TIER 4B (FINAL), Pilot Controls, Two-Wheel Drive (2WD), Power Shuttle, Cab , B95C TIER 4B (FINAL), Pilot Controls, Two-Wheel Drive (2WD), Power Shuttle, Canopy



Mechanical Controls, Four-Wheel Drive (4WD), Power Shuttle, Canopy , B95C TIER 4B (FINAL), Mechanical Controls, Four-Wheel Drive (4WD), Powershift, Cab , B95C TIER 4B (FINAL), Mechanical Controls, Two-Wheel Drive (2WD), Power Shuttle, Cab , B95C TIER 4B (FINAL), Mechanical Controls, Two-Wheel Drive (2WD), Power Shuttle, Canopy , B95C TIER 4B (FINAL), Pilot Controls, Four-Wheel Drive (4WD), Power Shuttle, Cab , B95C TIER 4B (FINAL), Pilot Controls, Four-Wheel Drive (4WD), Power Shuttle, Canopy , B95C TIER 4B (FINAL), Pilot Controls, Four-Wheel Drive (4WD), Powershift, Cab , B95C TIER 4B (FINAL), Pilot Controls, Two-Wheel Drive (2WD), Power Shuttle, Cab , B95C TIER 4B (FINAL), Pilot Controls, Two-Wheel Drive (2WD), Power Shuttle, Canopy

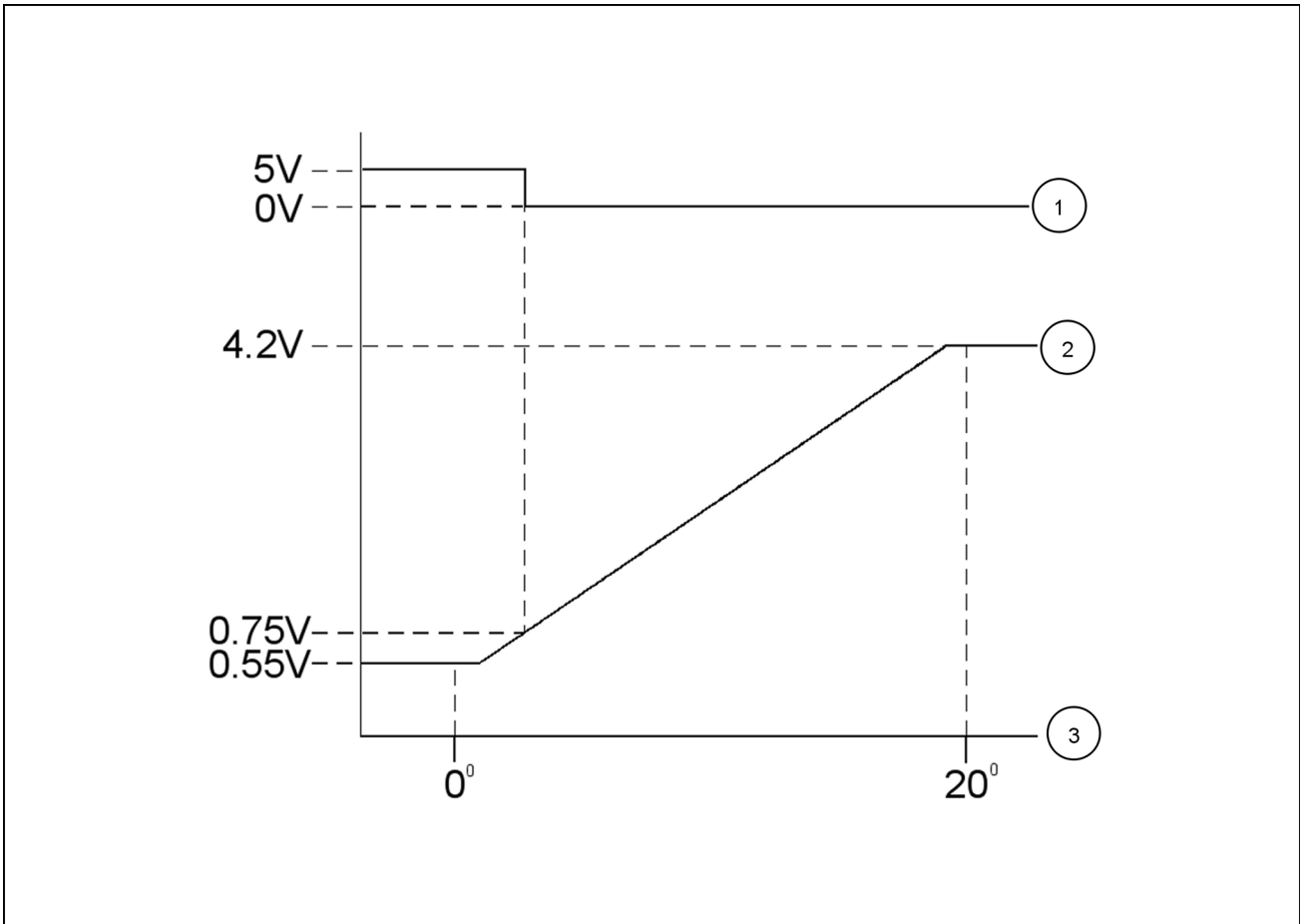

RCPH10TLB017GAM 1

Throttle Signal Legend	
(1)	Idle Validation Signal
(2)	Throttle Signal Voltage
(3)	Throttle movement in degrees of travel. 0 degrees equals low idle. 20 degrees equals WOT (Wide Open Throttle).

This step is used to monitor the throttle validation signal. The sensor must be connected and active in order to continue. The dealer must provide a breakout Tee or connector back probes in order to complete this procedure.

Connect the break out tee and measure the voltage from **X-025 pin 3** to **X-025 pin 6** (or slide back probes into pin 3 and 6).

Turn the ignition switch ON, engine OFF.

Measure the voltage from pin 3 to pin 6. Move the throttle from low idle to WOT (wide open throttle). The voltage should change from approximately **0.55 V** at low idle to **4.2 V** at WOT.

A. The voltage measurement is correct. Go to step 5.

B. The voltage was not between **0.55 V** to **4.2 V** as the throttle moved from low idle to WOT or the voltage was greater than **4.75 V** at WOT. Temporarily replace the sensor and retest. Return to step 1 to confirm elimination of fault.

5. Measure the throttle signal from the sensor to the instrument cluster.

Turn the ignition switch OFF.

Remove the breakout harness and reconnect the sensor to the instrument cluster harness.

Remove foot throttle switch wire **XST2 pin 16**.

Measure the voltage between **XST2 pin 16** and chassis ground. The chassis ground connection must be clean and free of paint, oil, and dirt. Move the throttle from low idle to WOT (wide open throttle). The voltage should change from approximately **0.55 V** at low idle to **4.2 V** at WOT.

A. The voltage changed between **0.55 V** and **4.2 V**. Temporarily replace the instrument cluster and retest. Return to step **1** to confirm elimination of the fault.

B. The voltage did not change between **0.55 V** and **4.2 V** as the throttle moved from low idle to WOT or the voltage was less than **0.5 V** at low idle. There is a problem in the throttle signal wire from the sensor to the instrument cluster. Repair or replace the wire as required. Return to step **1** to confirm elimination of fault.

Wiring harnesses - Electrical schematic sheet 15 (55.100)

1050-Alternator L+ terminal under 1.5 volts for 5 seconds

NOTE: The battery must be at full charge, and all connections must be clean and tight before testing the electrical system.

Context:

The instrument cluster measures a voltage less than **1.5 V** for a period greater than **5 s** on connector **XST2 pin 24**. The instrument cluster will illuminate the battery warning symbol when it detects a problem in the battery charging system. The instrument cluster will illuminate the warning lamp and will sound the alarm for one second on the next system power up following the event.

Cause:

The instrument cluster measures a voltage less than **1.5 V** for a period greater than **5 s** on connector **XST2 pin 24**.

Possible failure modes:

1. Wiring or circuits open.
2. Alternator output voltage is less than **11 V**.
3. Faulty reading from instrument cluster.

Solution:

1. Verify that the fault code is active.

Connect the Electronic Service Tool to the service tool connector.

To check for fault code: Start and operate machine.

A. The fault code is not recorded again. OK to return the machine to service.

B. Fault code 1050 is recorded again. Go to step **2**.

2. Verify that the wiring and connectors are free of damage.

Inspect the alternator and battery connections. All connections should be secure, tight, free of corrosion, abrasion and damage.

Inspect the harness from the alternator and battery to the instrument cluster. Verify that the harness is free of damage, corrosion, abrasion or incorrect attachment.

A. All connections are secure and the harness is free of damage. Go to step **3**.

B. The connectors or the harness has damage. Repair or replace the harness or connectors as required. Return to step **1** to confirm elimination of the fault.

3. Test the alternator output.

Start the engine. Set engine speed to low idle.

Measure the voltage at the alternator output. The voltage should be approximately **14.5 V**.

A. The alternator voltage is less than **11 V**. Temporarily replace the alternator and retest. Return to step **1** to confirm elimination of fault.

B. The alternator output voltage is approximately **14.5 V**. Go to step **4**.

4. Measure the voltage at instrument cluster.

Disconnect the instrument cluster connector **XST2**.

Start the engine. Set engine speed to low idle.

Measure the voltage between **XST2 pin 24** and chassis ground. The voltage should be approximately **14.5 V**. Wiggle the harness during measurement to reveal an intermittent condition.

From	To	Value
X-9138 pin 16	All pins in connector X-9138	There should be no continuity.
X-9138 pin 15	All pins in connector X-9138	There should be no continuity.

With the key in the OFF position, use a multimeter to perform the following voltage check, for a short to battery voltage source condition, on the engine harness (EN) side :

From	To	Value
X-9005 pin 1	Chassis ground	There should be no voltage.

With the key in the ON position, use a multimeter to perform the following voltage check, for a short to switched battery voltage condition, on the engine harness (EN) side :

From	To	Value
X-9005 pin 1	Chassis ground	There should be no voltage.

- A. If the specified values are measured, leave connectors **X-9005** and **X-9138** disconnected and continue to Step 4.
- B. If the specified values are not measured, there is a failure in the fuel temperature sensor B-9002 circuit wiring in the engine harness (EN). Locate and repair the failed conductor or conductors.
4. Check the fuel temperature sensor B-9002 circuit wiring in the vehicle harness (VE).

Disconnect the vehicle harness (VE) from the ECU A-9000 at connector **X-9121**.

With the key in the OFF position, use a multimeter to perform the following continuity check, for an open circuit condition, on the vehicle harness (VE) side :

From	To	Value
X-9138 pin 16	X-9121 pin A38	There should be continuity.
X-9138 pin 15	X-9121 pin A23	There should be continuity.

With the key in the OFF position, use a multimeter to perform the following continuity check, for a short to another circuit condition, on the vehicle harness (VE) side :

From	To	Value
X-9138 pin 16	All pins in connector X-9138	There should be no continuity.
X-9138 pin 15	All pins in connector X-9138	There should be no continuity.
X-9121 pin A38	All pins in connector X-9121	There should be no continuity.
X-9121 pin A23	All pins in connector X-9121	There should be no continuity.

With the key in the OFF position, use a multimeter to perform the following voltage check, for a short to battery voltage source condition, on the vehicle harness (VE) side :

From	To	Value
X-9121 pin A38	Chassis ground	There should be no voltage.

With the key in the ON position, use a multimeter to perform the following voltage check, for a short to switched battery voltage condition, on the vehicle harness (VE) side :

From	To	Value
X-9121 pin A38	Chassis ground	There should be no voltage.

- A. If the specified values are not measured, there is a fault in the fuel temperature sensor B-9002 circuit wiring in the vehicle harness (VE). Use the appropriate service manual, if necessary, to locate and repair the damaged conductor or conductors.
- B. If the specified values are measured, check the ECU A-9000 for the appropriate software and re-flash, if necessary.
5. Visually inspect the relevant harnesses and connectors for damage, bent or dislocated pins, corroded terminals, or broken wires.

3079-Short circuit error of injector in cylinder 4

Context:

The Engine Control Unit (ECU) A-9000 monitors the fuel injector power stages for a short circuit condition. If the ECU A-9000 detects a short circuit condition in the injector number 4 Y-9004 circuit, this fault will occur.

Cause:

The ECU A-9000 has detected a short circuit in the fuel injector number 4 Y-9004 circuit.

Possible failure modes:

1. Faulty fuel injector number 4 Y-9004, wiring.
2. Faulty fuel injector number 4 Y-9004, internal failure.
3. Faulty ECU A-9000, software.

Solution:

1. Verify this fault code is still present and in an active state.

Use the Easy Engine software provided on the Electronic Service Tool (EST) to check the fault status and to perform the cylinder cut-out test.

A. If the fault is still present and active, continue with Step 2.

B. If the fault is no longer present or is in an inactive state, the fault may be intermittent and not currently active. Continue with Step 8.

2. Check the fuel injector number 4 Y-9004 internal resistance.

Disconnect the injector harness (INJ) from the fuel injector number 4 Y-9004 at connector **X-9032**.

Use a multimeter to measure the resistance of fuel injector number 4 Y-9004 on the injector pins :

From	To	Value
X-9032 pin 1	X-9032 pin 2	There should be between .03 - .05 Ω

A. If there is between **.03 - .05 Ω**, leave connector **X-9032** disconnected and continue to Step 3.

B. If the resistance is not between **.03 - .05 Ω**, fuel injector number 4 Y-9004 solenoid coil has failed. Replace fuel injector number 4 Y-9004.

3. Check the fuel injector number 4 Y-9004 injector harness (INJ) wiring for a short to a voltage source.

With the key in the OFF position, use a multimeter to perform the following voltage check on the injector harness (INJ) side :

From	To	Value
X-9032 pin 1	Chassis ground	There should be no voltage.
X-9032 pin 2	Chassis ground	There should be no voltage.

With the key in the ON position, use a multimeter to perform the following voltage check on the injector harness (INJ) side :

From	To	Value
X-9032 pin 1	Chassis ground	There should be no voltage.
X-9032 pin 2	Chassis ground	There should be no voltage.

A. If there is no voltage, leave connector **X-9032** disconnected and continue to Step 4.

B. If there is voltage, there is a short to battery or switched battery in the fuel injector number 4 Y-9004 wiring in the injector harness (INJ). Use the appropriate service manual, if necessary, to locate and repair the shorted conductor.

3105-Fuel pressure relief valve is forced to open, perform pressure increase

NOTE: If the Pressure Relief Valve (PRV) is replaced, it is necessary to perform the Replacement of the Rail Pressure Relief Valve (PRV) - Reset ECU Data with the Electronic Service Tool (EST) before you return the machine to service. Refer to the engine service manual **Common rail Relief valve - Configure - Reset ECU data (10.218)**, if necessary.

NOTE: If the rail pressure sensor B-9004 is replaced, it is necessary to perform the Replacement of the Rail Pressure sensor - Reset ECU Data with the Electronic Service Tool (EST) before you return the machine to service. Refer to the engine service manual **Common rail pressure sensor - Configure - Reset ECU data (Rail pressure sensor) (55.010)**, if necessary.

Context:

The Engine Control Unit (ECU) A-9000, if necessary, will set the engine into limp home mode. This process is achieved in two steps by the ECU A-9000, a pressure increase and a pressure shock. The ECU A-9000 will execute step one by a fuel pressure increase. This is achieved by fully opening the fuel metering unit Y-9000, thus allowing maximum fuel delivery. If this fault is active, the ECU A-9000 has performed step one for achieving limp home mode, a fuel pressure increase. Other active faults may have caused this fault to occur. For more information regarding fuel system troubleshooting, refer to the engine service manual **Fuel injection system - Troubleshooting (10.218)**.

Cause:

The ECU A-9000 has performed a fuel pressure increase to achieve limp home mode.

3200-Open load error of injector in cylinder 3

Context:

The Engine Control Unit (ECU) A-9000 monitors the fuel injector number 3 Y-9003 circuit. If the ECU A-9000 determines that there is an open circuit condition in the fuel injector number 3 Y-9003 circuit, this fault will occur.

Cause:

The ECU A-9000 has detected an open circuit in the fuel injector number 3 Y-9003 circuit.

Possible failure modes:

1. Faulty fuel injector number 3 Y-9003, internal failure.
2. Faulty fuel injector number 3 Y-9003 wiring, open circuit.
3. Faulty ECU A-9000, software.

Solution:

1. Verify fault is present and active.

Use the Electronic Service Tool (EST) to check the status of this fault.

A. If the fault is present and active, continue with Step 2.

B. If the fault is no longer present or in an inactive state, the fault may be intermittent and not currently active. Continue with Step 5.

2. Check fuel injector number 3 for an internal failure.

Disconnect connector **X-9031** from fuel injector number 3 Y-9003.

Use a multimeter to perform the following resistance check on the fuel injector pins :

From	To	Value
X-9031 pin 1	X-9031 pin 2	There should be approximately 0.3 - 0.5 Ω .

A. If the resistance is significantly greater than the specified range, the fuel injector has failed. Replace the fuel injector number 3 Y-9003.

B. If the specified range is measured, leave connector **X-9031** disconnected and continue to Step 3.

3. Check the fuel injector number 3 Y-9003 injector harness (INJ) wiring for an open circuit.

Disconnect connector **X-9139** from the engine interface connector.

Use a multimeter to perform the following continuity check on the injector harness (INJ) side :

From	To	Value
X-9139 pin D	X-9031 pin 1	There should be continuity.
X-9139 pin C	X-9031 pin 2	There should be continuity.

A. If there is no continuity, there is an open circuit in the fuel injector number 3 Y-9003 injector harness (INJ) wiring. Locate and repair the broken conductor.

B. If there is continuity, leave connectors **X-9031** and **X-9139** disconnected and continue to Step 4.

4. Check the fuel injector number 3 Y-9003 vehicle harness (VE) wiring for an open circuit.

Disconnect the vehicle harness (VE) from the ECU A-9000 at connector **X-9121**.

Use a multimeter to perform the following continuity check on the vehicle harness (VE) side :

4. Visually inspect the relevant harnesses and connectors for damage, bent or dislocated pins, corroded terminals, or broken wires. Verify that the connectors are fully installed. Flex the harnesses involved to reveal intermittent breaks or shorts in the wiring concerned. Operate the machine while you monitor the display.
 - A. If you find damage or the display indicates other than normal display readings, then repair the damage discovered during the inspection or locate and repair the other than normal display condition and verify that the error has been resolved.
 - B. If you do not find damage and the display indicates only normal readings, then erase the fault code and continue operation.

Wiring harnesses - Electrical schematic sheet 01 – Power distribution and starting (55.100.DP-C.20.E.01)

Wiring harnesses - Electrical schematic sheet 04 – Engine Control Unit (ECU) vehicle connector (55.100.DP-C.20.E.04)

3369-Torque limitation caused by smoke limitation

Context:

Torque is limited during acceleration to prevent smoke emissions due to a lean mixture. Therefore the fuel quantity is limited to a minimum air/fuel ratio, depending on the actual engine speed and the actual air flow. This reduction is usual and the duration normally less than **1.00 s**. If there was a power reduction greater than **25 %** or an engine speed limitation greater than **25 %** due to smoke limitation for more than **120.00 s** a fault code was stored. This fault code is for information only and does not require any further action. That there was an active performance limitation due to smoke limitation, which lasted longer than usually expected. If no other failure is stored in memory concerning Exhaust Gas Recirculation (EGR) or intake manifold pressure control or if failure occurred at high altitude **1800 m (5906 ft)** (less than **0.78 bar (11.31 psi)** ambient pressure), no action is needed. Check applicable actuators of EGR, intake manifold pressure and exhaust flap control for sticking. Check turbocharger for correct efficiency. Check applicable air flow and intake manifold pressure sensors for correct measuring. If other fault codes are present concerning EGR or intake manifold pressure that could influence smoke limitation, those faults could pinpoint an actual failure. Follow the troubleshooting procedure for the other fault.

3526-Downstream NO_x sensor internal failure (Short Circuit Error)

NOTE: Because this fault causes inducement, it is necessary to perform the SCR Fault Repair Verification Test once the fault has been resolved. Refer to the engine service manual **Selective Catalytic Reduction (SCR) exhaust treatment - Service instruction - SCR fault repair verification test (10.500)** if necessary.

NOTE: Because this fault causes inducement, it is necessary to perform the Engine Restart Counter Reset / Unlock Inducement configuration with the Electronic Service Tool (EST) before you return the machine to service. Refer to the engine service manual **Selective Catalytic Reduction (SCR) exhaust treatment - Configure - Engine restart counter reset (10.500)**, if necessary.

Context:

For information regarding the functional operation of the smart Selective Catalytic Reduction (SCR) downstream NO_x sensor A-9102, refer to the engine service manual **Nitrogen Oxides (NO_x) sensor - Dynamic description (55.988)**. The SCR downstream NO_x sensor A-9102 has internal monitoring for open wire or short circuit and sends an error status in case of a detected failure. This failure is the result of a short circuit error in the sensor NO_x and/or Oxygen level circuit.

Cause:

The SCR downstream NO_x sensor A-9102 has reported, via CAN, to the ECU A-9000 that a short circuit condition exists in the NO_x and/or Oxygen level circuit.

Possible failure modes:

1. Faulty SCR downstream NO_x sensor A-9102, hardware or firmware.
2. Faulty ECU A-9000, software.

Solution:

1. Verify fault is present and active.

Use the Electronic Service Tool (EST) to check the status of this fault.

A. If the fault is present and active, continue with Step 2.

B. If the fault is no longer present or in an inactive state, the fault may be intermittent and not currently active. Continue with Step 3.

2. As there is no method for field testing or re-flashing the sensor controller, replace the SCR downstream NO_x sensor A-9102.

Then use the EST, refer to the engine service manual **Nitrogen Oxides (NO_x) sensor - Configure - Reset ECU data (Downstream sensor) (55.988)**, if necessary, to perform the Replacement of Nox Downstream Sensor - Reset ECU Data configuration.

Then use the EST, refer to the engine service manual **Selective Catalytic Reduction (SCR) exhaust treatment - Configure - Engine restart counter reset (10.500)**, if necessary, to perform the Engine Restart Counter Reset / Unlock Inducement configuration.

Then perform the SCR Fault Verification Test, refer to the engine service manual **Selective Catalytic Reduction (SCR) exhaust treatment - Service instruction - SCR fault repair verification test (10.500)**, if necessary.

Then check to see that this fault is resolved.

A. If this fault is resolved, return the machine to service.

B. If this fault is not resolved, check the ECU A-9000 for the appropriate software and re-flash, if necessary.

3. Visually inspect the relevant harnesses and connectors for damage, bent or dislocated pins, corroded terminals, or broken wires. Verify that the connectors are fully installed. Flex the harnesses involved to reveal intermittent breaks or shorts in the wiring concerned. Operate the machine while you monitor the display.

3742-ECU internal failure - SPI errors during MoCSOP execution

Context:

The Engine Control Unit (ECU) A-9000 tests the correct functioning of the fuel injection path shut off procedure. During this test, each injection path is shortly activated during ECU A-9000 initialization. If a Serial Peripheral Interface (SPI) communication error is detected during this test, this fault will occur.

Solution:

1. Check the ECU A-9000 for the appropriate software and re-flash, if necessary.
 - A. If the fault has been resolved, return the machine to service.
 - B. If the fault has not been resolved, escalate an ASIST concern.

3795-Plausibility Check for air pressure at the upstream of intake valve sensor

Context:

The Engine Control Unit (ECU) A-9000 monitors boost pressure. Boost pressure is compared to environmental pressure by the ECU A-9000. If the ECU A-9000 determines that the boost pressure is less than environmental pressure by **0.1 bar (1.5 psi)**, this fault will occur.

Cause:

The ECU A-9000 has determined that boost pressure is less than environmental pressure by **0.1 bar (1.5 psi)**.

Possible failure modes:

1. Faulty intake manifold pressure sensor B-9001, internal failure.
2. Faulty ECU A-9000, software.

Solution:

1. Verify fault is present and active.

Use the Electronic Service Tool (EST) to check the status of this fault.

A. If the fault is present and active, continue with Step 2.

B. If the fault is no longer present or in an inactive state, the fault may be intermittent and not currently active. Continue with Step 4.

2. Use the Electronic Service Tool (EST) to check for related faults:

A. If any faults are active, diagnose them first and then return to this fault.

B. If none of the listed faults are active, continue to Step 3.

3. Replace the intake manifold pressure sensor B-9001.

Use the EST to verify the status of this fault.

A. If the fault is no longer active, return the machine to service.

B. If the fault is still active, check the ECU A-9000 for the appropriate software and re-flash, if necessary.

4. Visually inspect the relevant harnesses and connectors for damage, bent or dislocated pins, corroded terminals, or broken wires. Verify that the connectors are fully installed. Flex the harnesses involved to reveal intermittent breaks or shorts in the wiring concerned. Operate the machine while you monitor the display.

A. If you find damage or the display indicates other than normal display readings, then repair the damage discovered during the inspection or locate and repair the other than normal display condition and verify that the error has been resolved.

B. If you do not find damage and the display indicates only normal readings, then erase the fault code and continue operation.

4002-Power supply for digital outputs (pin 8) does not have power

B110C TIER 4B (FINAL), Mechanical Controls, Four-Wheel Drive (4WD), Powershift, Cab	
B110C TIER 4B (FINAL), Pilot Controls, Four-Wheel Drive (4WD), Powershift, Cab	
B95C TC TIER 4B (FINAL), Pilot Controls, Four-Wheel Drive (4WD), Powershift, Cab	
B95C TIER 4B (FINAL), Mechanical Controls, Four-Wheel Drive (4WD), Powershift, Cab	
B95C TIER 4B (FINAL), Pilot Controls, Four-Wheel Drive (4WD), Powershift, Cab	

Context:

The Trax control module does not detect battery voltage on **X401 pin 8**. The power supply for the digital outputs on the Trax control module is not functioning. The transmission will shift into Limp Home mode in 2nd gear, without modulation. While this fault is active, the instrument cluster will illuminate the warning lamp.

Cause:

The Trax control module does not detect battery voltage on **X401 pin 8**.

Possible failure modes:

1. Open circuit in the battery supply to the Trax control module.
2. Faulty Trax control module.

Solution:

1. Verify that the fault code is still active.

Use the Electronic Service Tool to clear all fault codes.

To check for fault code: Start and operate machine.

A. Fault is not recorded again. OK to return the machine to service.

B. Fault code 4002 is recorded again. Go to step 2.

2. Verify that the wiring and connectors are free of damage.

Inspect the connections to the ignition switch and the Trax control module. All connections should be secure and tight.

Inspect the harness from the ignition switch to the Trax control module. Verify that the harness is free of damage, corrosion, abrasion and incorrect attachment.

A. The connectors are secure and the harness is free of damage. Go to step 3.

B. The connectors or harness is damaged. Repair or replace harness or connectors as needed. Return to step 1 to confirm elimination of fault.

3. Measure at voltage at the Trax control module.

Lift the floor board to expose the Trax control module.

Turn the ignition switch ON.

Measure the voltage between **X401 pin 8** and chassis ground. The chassis ground connection must be clean and free of paint, oil, and dirt. The voltage should be between **11 V** and **14.5 V**. Wiggle the harness during measurement to reveal an intermittent condition.

A. The voltage is correct. Temporarily replace the Trax control module and retest. Return to step 1 to confirm elimination of the fault.

B. The voltage is less than **11 V**. There is a problem in the battery supply to **X401 pin 8**. Repair as required. Return to step 1 to confirm elimination of the fault.

A. The voltage measurement is less than **0.5 V**. Go to step **4**.

B. The voltage is greater than **0.5 V**. There is a short circuit to another voltage source. Repair or replace the harness as required. Return to step **1** to confirm elimination of fault.

4. Measure the resistance of the 1/3 solenoid.

Turn the ignition switch OFF.

Disconnect connector X102A from the 1/3 solenoid.

Measure the resistance of the solenoid across the solenoid terminals. The resistance should be approximately **7.25 Ω**.

A. If the resistance is between **6.25 Ω** and **8 Ω**, temporarily replace the Trax control module and retest. Return to step **1** to confirm elimination of the fault.

B. If the resistance is less than **6.25 Ω** the 1/3 solenoid has an internal short circuit. Replace the 1/3 solenoid and retest. Return to step **1** to confirm elimination of fault.

Wiring harnesses - Electrical schematic sheet 26 – Transmission - Trax (55.100.DP-C.20.E.26)

Wiring harnesses - Electrical schematic sheet 27 – Transmission - Carraro (55.100.DP-C.20.E.27)

Place the FNR switch in the reverse position.

Measure the voltage between pin 5 and chassis ground. The voltage should be approximately **12 V**.

Measure the voltage between pin 7 and chassis ground. The voltage should be less than **0.5 V**.

A. The voltage on pin 5 is between **11 V** and **14.5 V** and the voltage on pin 7 is less than **0.5 V**. Go to step **4**.

B. The voltage on pin 5 is between **11 V** and **14.5 V** and the voltage on pin 7 is between **11 V** and **14.5 V**. Temporarily replace the FNR shift lever and retest. Return to step **1** to confirm elimination of fault.

4. Measure the resistance through the harness.

Turn the ignition switch OFF.

Disconnect **X401** from the Trax control module.

Measure the resistance between **X401 pin 18** and **X401 pin 46**. The resistance should be greater than **20,000 Ω**. Wiggle the harness during measurement to reveal an intermittent condition.

A. The resistance is greater than **20,000 Ω**. Go to step **5**.

B. The resistance is less than **20,000 Ω**. There is a short circuit between **X401 pin 18** and **X401 pin 46**. Repair or replace the harness as required. Return to step **1** to confirm elimination of fault.

5. Measure the voltage at the Trax control connector.

Remove the breakout tee from the harness and FNR switch.

Reinstall pin 5 and pin 7 in the FNR connector. Reconnect the FNR harness connector to the FNR switch.

Turn the ignition switch ON.

Place the FNR switch in the reverse position.

Measure the voltage between **X401 pin 18** and chassis ground. The voltage should be less than **0.5 V**. Wiggle the harness during measurement to reveal an intermittent condition.

Measure the voltage from **X401 pin 46** and chassis ground. The voltage should be approximately **12 V**. Wiggle the harness during measurement to reveal an intermittent condition.

A. The voltage on pin 18 is less than **0.5 V** and the voltage on pin 46 is between **12 V** and **14.5 V**. Temporarily replace the Trax control and retest. Return to step **1** to confirm elimination of the fault.

B. The voltage on pin 18 is between **11 V** and **14.5 V** and the voltage on pin 46 is between **11 V** and **14.5 V**. There is a short circuit between **X401 pin 18** and **X401 pin 46**. Repair or replace the harness as required. Return to step **1** to confirm elimination of fault.

Wiring harnesses - Electrical schematic sheet 26 – Transmission - Trax (55.100.DP-C.20.E.26)

4100-Missing EEC 1 message on CAN

B110C TIER 4B (FINAL), Mechanical Controls, Four-Wheel Drive (4WD), Powershift, Cab	
B110C TIER 4B (FINAL), Pilot Controls, Four-Wheel Drive (4WD), Powershift, Cab	
B95C TC TIER 4B (FINAL), Pilot Controls, Four-Wheel Drive (4WD), Powershift, Cab	
B95C TIER 4B (FINAL), Mechanical Controls, Four-Wheel Drive (4WD), Powershift, Cab	
B95C TIER 4B (FINAL), Pilot Controls, Four-Wheel Drive (4WD), Powershift, Cab	

Context:

CAN Data Link communications between the Trax Control and the Engine Control Unit (ECU) have been lost.

Cause:

CAN Data Link communications between the Trax Control and the ECU have been lost. The Trax Control did not receive the EEC1 message from the ECU. This fault code may be displayed with other Trax CAN Data Link fault messages indicating a failure in the Trax CAN Data Link circuit.

Possible failure modes:

1. CAN data link wiring or circuits open.
2. CAN data link wiring or circuits shorted.
3. Faulty ECU.
4. Faulty Trax control module.

Solution:

1. Verify that the fault code is active.

Connect the Electronic Service Tool to the service tool connector.

To check for fault code: Start and operate machine.

If three or more fault codes are active, 3096, 3334, 1051 through 1059, this is an indication of a problem in the CAN Data Link circuit, continue with this procedure. If one or two CAN Data Link fault codes are active, this is an indication of an intermittent connection in the CAN circuit. Check all wires and connectors to verify they are secure and free of damage, corrosion, abrasion or incorrect attachment.

A. CAN Data Link fault codes are not recorded again and are no longer ACTIVE. OK to return the machine service.

B. CAN Data Link fault codes are present and ACTIVE. Go to Step 2.

2. Verify the harness is not damaged.

Turn the key switch OFF.

Verify the connections to the ECU, Instrument Cluster, diagnostic connector, Trax control (if installed) and the optional Telematics unit are tight and secure.

Verify the harness is free of damage, abrasion, corrosion and incorrect attachment from the ECU to the Instrument Cluster. Verify all data link drops are free of damage, abrasion, corrosion and incorrect attachment.

A. The CAN Data Link harness is not damaged and all connections are secure. Go to Step 3.

B. The harness is damaged or the connectors are loose or damaged. Repair or replace the harness as required. Go to Step 1 to confirm elimination of fault.

3. Measure the resistance through the CAN Data Link harness.

Turn the key switch OFF.

9009-A/D fault foot throttle power, internal error

Cause:

1. Faulty instrument cluster.

Solution:

1. Verify that the fault code is active.

Connect the Electronic Service Tool to the service tool connector.

To check for fault code: Start and operate machine.

A. Fault is not recorded again. OK to return the machine to service.

B. Fault code 9009 is recorded again. Go to step **2**.

2. Replace instrument cluster.

A. Return to step **1** to confirm elimination of fault.

- A. If there is no voltage on either of the checks, the short to a voltage source condition is in the engine harness (EN) between connector **X-9010 pin 1** or **X-9010 pin 5** and connector **X-9138 pin 29** or **X-9138 pin 30**. Locate and repair the damaged conductors.
 - B. If there is voltage on either or both of the checks, the short to a voltage source condition is in the vehicle harness (VE) between connector **X-9138 pin 29** and/or **X-9138 pin 30** and connector **X-9121 pin A50** and/or connector **X-9121 pin A35**. Use the appropriate service manual, if necessary, to locate and repair the damaged conductors.
8. Check the EGR valve Z-9000 motor actuator control circuit for a short to another circuit condition.

Use a multimeter to check for continuity on the vehicle harness (VE) side :

From	To	Result
X-9121 pin A50	to all other pins in connector X-9121	There should be no continuity.
X-9121 pin A35	to all other pins in connector X-9121	There should be no continuity.

- A. If there is continuity on any of the tests, there is a short to another circuit condition in the vehicle harness (VE) between connector **X-9121 pin A50** and/or **X-9121 pin A35**, and another circuit. Use the appropriate service manual, if necessary, to locate and repair the damaged conductors.
 - B. If there is no continuity on any of the checks, check the ECU A-9000 for the appropriate software and re-flash, if necessary.
9. Visually inspect the relevant harnesses and connectors for damage, bent or dislocated pins, corroded terminals, or broken wires. Verify that the connectors are fully installed. Flex the harnesses involved to reveal intermittent breaks or shorts in the wiring concerned. Operate the machine while you monitor the display.
- A. If you find damage or the display indicates other than normal display readings, then repair the damage discovered during the inspection or locate and repair the other than normal display condition and verify that the error has been resolved.
 - B. If you do not find damage and the display indicates only normal readings, then erase the fault code and continue operation.

Wiring harnesses - Electrical schematic sheet 05 – Engine Control Unit (ECU) engine connector (55.100.DP-C.20.E.05)

Wiring harnesses - Electrical schematic sheet 06 – Engine control and fuel injection (55.100.DP-C.20.E.06)

17380-Measured injection closing time exceeds a limit

Context:

The Engine Control Unit (ECU) A-9000 monitors for a difference between the measured closing time of the fuel injector to a reference value from an internal map which is derived from the injector IMA code. If the closing time or energizing time exceeds the minimum or maximum values in the tolerance curve, this fault will occur.

Cause:

The ECU A-9000 has determined that the fuel injector number 3 Y-9003 IMA programming is wrong or the injector has drifted.

Solution:

1. Use the Electronic Service Tool (EST) to ensure that the correct IMA code is programmed to the fuel injector number 3 Y-9003.

A. If the correct code is not programmed. Use the EST to program the correct code.

B. If the correct code is programmed, continue to Step 2.

NOTE: The IMA code may be under the paint on the fuel injector.

NOTE: For more information regarding programming IMA codes, refer to the engine service manual **Fuel injectors - Configure - IMA codes (10.218)**.

2. Replace the fuel injector number 3 Y-9003.

Then check to see that this fault has been resolved.

A. If the fault has been resolved, return the machine to service.

B. If the fault has not been resolved, check the ECU A-9000 for the appropriate software and re-flash, if necessary.

17417-Short circuit to ground error

Context:

The Engine Control Unit (ECU) A-9000 controls the Selective Catalytic Reduction (SCR) relay K-9111 with a low side driver control circuit. If the ECU A-9000 detects a short circuit to ground condition in the low side driver circuit, this fault will occur.

Cause:

The ECU A-9000 has detected a short circuit to ground condition in the SCR K-9111 low side driver control circuit.

Possible failure modes:

1. Faulty SCR relay K-9111 wiring, short circuit to ground.
2. Faulty ECU A-9000, software.

Solution:

1. Verify the fault is present and active.

Use the Electronic Service Tool (EST) to check the status of this fault.

- A. If the fault is present and active, continue with Step 2.
- B. If the fault is no longer present or in an inactive state, the fault may be intermittent and not currently active. Continue with Step 3.

2. Check the SCR relay K-9111 vehicle harness (VE) wiring for a short circuit to ground condition.

Remove the SCR relay K-9111 from its socket.

With the key in the OFF position, use a multimeter to perform the following continuity check, for a short circuit to ground condition, on the vehicle harness (VE) side :

From	To	Value
X-9128 pin 85	chassis ground	There should be no continuity.

- A. If there is continuity, there is a short circuit to ground condition in the SCR relay K-9111 control circuit wiring in the vehicle harness (VE). Use the appropriate service manual, if necessary, to locate and repair the damaged conductor.
 - B. If there is no continuity, check the ECU A-9000 for the appropriate software and re-flash, if necessary.
3. Visually inspect the relevant harnesses and connectors for damage, bent or dislocated pins, corroded terminals, or broken wires. Verify that the connectors are fully installed. Flex the harnesses involved to reveal intermittent breaks or shorts in the wiring concerned. Operate the machine while you monitor the display.
 - A. If you find damage or the display indicates other than normal display readings, then repair the damage discovered during the inspection or locate and repair the other than normal display condition and verify that the error has been resolved.
 - B. If you do not find damage and the display indicates only normal readings, then erase the fault code and continue operation.

Wiring harnesses - Electrical schematic sheet 01 – Power distribution and starting (55.100.DP-C.20.E.01)

Wiring harnesses - Electrical schematic sheet 05 – Engine Control Unit (ECU) engine connector (55.100.DP-C.20.E.05)

17465-Open Load error in powerstage of Urea dosing valve actuator

Context:

The Engine Control Unit (ECU) A-9000 controls the operation of the Diesel Exhaust Fluid (DEF)/AdBlue® dosing module Y-9103 solenoid with both a high side and low side driver control circuit. The ECU A-9000 monitors each of the drivers separately. If the ECU A-9000 detects an open circuit condition in the low side driver circuit, this fault will occur.

Cause:

The ECU A-9000 has detected an open circuit condition in the DEF/AdBlue® dosing module Y-9103 low side driver control circuit.

Possible failure modes:

1. Faulty DEF/AdBlue® dosing module Y-9103, internal failure.
2. Faulty DEF/AdBlue® dosing module Y-9103 low side driver circuit wiring, open circuit.
3. Faulty ECU A-9000, software.

Solution:

1. Verify the fault is present and active.

Use the Electronic Service Tool (EST) to check the status of this fault.

A. If the fault is present and active, continue with Step 2.

B. If the fault is no longer present or in an inactive state, the fault may be intermittent and not currently active. Continue with Step 4.

2. Check the DEF/AdBlue® dosing module Y-9103 solenoid coil for an internal failure.

Disconnect the vehicle harness (VE) from the DEF/AdBlue® dosing module Y-9103 at connector **X-9110**.

Use a multimeter to measure the solenoid coil resistance on the DEF/AdBlue® dosing module Y-9103 pins :

From	To	Value
X-9110 pin 1	X-9110 pin 2	There should be approximately 10 - 15 Ω .

A. If there is approximately **10 - 15 Ω**, leave the DEF/AdBlue® dosing module Y-9103 disconnected and continue to Step 3.

B. If there is not approximately **10 - 15 Ω**, the DEF/AdBlue® dosing module Y-9103 has failed. Replace the DEF/AdBlue® dosing module Y-9103.

3. Check the DEF/AdBlue® dosing module Y-9103 vehicle harness (VE) low side driver circuit wiring for an open circuit condition.

Disconnect the vehicle harness (VE) from the ECU A-9000 at connector **X-9121**.

Place a jumper wire between connector **X-9121 pin A03** and chassis ground.

With the key in the OFF position, use a multimeter to perform the following continuity check, for an open circuit, on the vehicle harness (VE) side :

From	To	Value
X-9110 pin 1	chassis ground	There should be continuity.

A. If there is no continuity, there is an open circuit condition in the DEF/AdBlue® dosing module Y-9103 low side driver control circuit wiring in the vehicle harness (VE). Use the appropriate service manual, if necessary, to locate and repair the broken conductor.

B. If there is continuity, check the ECU A-9000 for the appropriate software and re-flash, if necessary.

With the key switch in the OFF position, use a multimeter to check for continuity on the vehicle harness (VE) side :

From	To	Value
X-9108 pin 2	chassis ground	There should be no continuity.

A. If there is voltage in the first check or continuity in the second check, there is a short to a voltage source or a short circuit to ground condition in the vehicle harness (VE) circuit wiring. Use the appropriate service manual, if necessary, to locate and repair the damaged conductors or grounded conductor.

B. If there is no voltage in the first check and no continuity in the second check, the ECU A-9000 has failed internally. Replace the ECU A-9000.

4. Check the vehicle harness (VE) data acquisition circuit wiring for an open or short circuit condition.

Disconnect the vehicle harness (VE) from the ECU A-9000 at connector **X-9122**.

Place a jumper wire between the vehicle harness (VE) side of connector **X-9122 pin K76** and chassis ground.

Use a multimeter to check for continuity on the vehicle harness (VE) side :

From	To	Value
X-9108 pin 2	chassis ground	There should be continuity.

Remove the jumper wire from the vehicle harness (VE) side of connector **X-9122 pin K76** and chassis ground.

Use a multimeter to check for continuity on the vehicle harness (VE) side :

From	To	Value
X-9122 pin K76	to all other pins on connector X-9122	There should be no continuity.

A. If there is no continuity in the first check or there is continuity in the second check, there is an open circuit or short to another circuit condition in the vehicle harness (VE) data acquisition circuit wiring. Use the appropriate service manual, if necessary, to locate and repair the broken conductor or shorted conductors.

B. If there is continuity in the first check and no continuity in the second check, continue with Step 5.

5. As there is no method of field testing or re-flashing the DEF/AdBlue® supply module Z-9102, replace the DEF/AdBlue® supply module Z-9102.

Then check to see that this fault has been resolved.

A. If the fault is resolved, return the machine to service.

B. If the fault is not resolved, check the ECU A-9000 for the appropriate software and re-flash, if necessary.

6. Visually inspect the relevant harnesses and connectors for damage, bent or dislocated pins, corroded terminals, or broken wires. Verify that the connectors are fully installed. Flex the harnesses involved to reveal intermittent breaks or shorts in the wiring concerned. Operate the machine while you monitor the display.

A. If you find damage or the display indicates other than normal display readings, then repair the damage discovered during the inspection or locate and repair the other than normal display condition and verify that the error has been resolved.

B. If you do not find damage and the display indicates only normal readings, then erase the fault code and continue operation.

**Wiring harnesses - Electrical schematic sheet 02 – Pre-start and Selective Catalytic Reduction (SCR)
(55.100.DP-C.20.E.02)**

**Wiring harnesses - Electrical schematic sheet 04 – Engine Control Unit (ECU) vehicle connector
(55.100.DP-C.20.E.04)**

Then use the EST, refer to the engine service manual **Selective Catalytic Reduction (SCR) exhaust treatment - Configure - Engine restart counter reset (10.500)** if necessary, to perform the Engine Restart Counter Reset / Unlock Inducement configuration.

Then check to see that this fault is resolved.

A. If the fault is resolved, return the machine to service.

B. If the fault is not resolved, check the ECU A-9000 for the appropriate software and re-flash, if necessary.

4. Visually inspect the relevant harnesses and connectors for damage, bent or dislocated pins, corroded terminals, or broken wires. Verify that the connectors are fully installed. Flex the harnesses involved to reveal intermittent breaks or shorts in the wiring concerned. Operate the machine while you monitor the display.

A. If you find damage or the display indicates other than normal display readings, then repair the damage discovered during the inspection or locate and repair the other than normal display condition and verify that the error has been resolved.

B. If you do not find damage and the display indicates only normal readings, then erase the fault code and continue operation.

Wiring harnesses - Electrical schematic sheet 03 – Exhaust system and Controller Area Network (CAN) bus (55.100.DP-C.20.E.03)

- A. If you find damage or the display indicates other than normal display readings, then repair the damage discovered during the inspection or locate and repair the other than normal display condition and verify that the error has been resolved.
- B. If you do not find damage and the display indicates only normal readings, then erase the fault code and continue operation.

19104-Short Circuit to Ground of DEF/AdBlue Supply Module Heater Actuator powerstage

Context:

The Heater Control Unit (HCU) A-9105 controls and monitors operation of the Diesel Exhaust Fluid (DEF)/AdBlue® supply module suction line heater R-9102, the DEF/AdBlue® supply module back-flow line heater R-9103, the DEF/AdBlue® supply module pressure line heater R-9104 and the Diesel Exhaust Fluid (DEF)/AdBlue® supply module Z-9102 internal heater. The DEF/AdBlue® supply module suction line heater R-9102 and the DEF/AdBlue® supply module back-flow line heater R-9103 are wired in series and share a high side driver controlled circuit. The DEF/AdBlue® supply module pressure line heater R-9104 and the DEF/AdBlue® supply module Z-9102 internal heater have their own high side driver controlled circuit. The HCU A-9105 communicates electrical failures, via Controller Area Network (CAN), to the Engine Control Unit (ECU) A-9000. If the HCU A-9105 senses a short circuit to ground condition in the DEF/AdBlue® supply module Z-9102 internal heater control circuit, this fault will occur.

Cause:

The HCU A-9105 has communicated, via CAN, to the ECU A-9000 that a short to ground circuit condition has been detected in the DEF/AdBlue® supply module Z-9102 internal heater circuit.

Possible failure modes:

1. Faulty DEF/AdBlue® supply module Z-9102 internal heater circuit wiring, grounded circuit.
2. Faulty DEF/AdBlue® supply module Z-9102 internal heater, internal failure.
3. Faulty HCU A-9105, internal failure.
4. Faulty ECU A-9000, software.

Solution:

1. Verify the fault is present and active.

Use the Electronic Service Tool (EST) to check the status of this fault.

A. If the fault is present and active, continue with Step 2.

B. If the fault is no longer present or in an inactive state, the fault may be intermittent and not currently active. Continue with Step 5.

2. Check the vehicle harness (VE) circuit wiring for a short to ground circuit condition.

Disconnect the vehicle harness (VE) from the HCU A-9105 at connector **X-9111**.

Use a multimeter to check for continuity on the vehicle harness (VE) side :

From	To	Value
X-9111 pin G1	chassis ground	There should be no continuity.

A. If there is continuity, leave connector **X-9111** disconnected and continue with Step 3.

B. If there is no continuity, continue with Step 4.

3. Locate the short to ground circuit condition.

Disconnect the vehicle harness (VE) from the DEF/AdBlue® supply module Z-9102 at connector **X-9108**.

Use a multimeter to check for continuity on the vehicle harness (VE) side :

From	To	Value
X-9111 pin G1	chassis ground	There should be no continuity.

A. If there is continuity, there is a short circuit to ground condition in the vehicle harness (VE) circuit wiring. Use the appropriate service manual, if necessary, to locate and repair the grounded conductor.

19262-DEF/AdBlue tank heater actuator short circuit to battery failure

Context:

The Engine Control Unit (ECU) A-9000 monitors the DEF/Adblue® tank heating valve Y-9102 circuit. If the ECU A-9000 detects a short to battery power condition in the DEF/Adblue® tank heating valve Y-9102 circuit, this fault will occur.

Cause:

The ECU A-9000 has detected a short to battery power condition in the DEF/Adblue® tank heating valve Y-9102 circuit.

Possible failure modes:

1. Faulty DEF/Adblue® tank heating valve Y-9102, internal failure.
2. Faulty DEF/Adblue® tank heating valve Y-9102 wiring.
3. Faulty ECU A-9000, software.

Solution:

1. Verify fault is present and active.

Use the Electronic Service Tool (EST) to check the status of this fault.

- A. If the fault is present and active, continue with Step 2.
- B. If the fault is no longer present or in an inactive state, the fault may be intermittent and not currently active. Continue with Step 5.

2. Check the DEF/Adblue® tank heating valve Y-9102 for an internal failure.

Disconnect the vehicle harness (VE) from the DEF/Adblue® tank heating valve Y-9102 at connector **X-9112**.

Use a multimeter to perform the following resistance check on the DEF/Adblue® tank heating valve Y-9102 pins :

From	To	Value
Y-9102 pin 1	Y-9102 pin 3	There should be between 11 - 16 Ω .

- A. If the value is within the specified range, leave connector **X-9112** disconnected and continue to Step 3.
- B. If the value is not within the specified range, the DEF/Adblue® tank heating valve Y-9102 has failed internally. Replace the DEF/Adblue® tank heating valve Y-9102.

3. Check the DEF/Adblue® tank heating valve Y-9102 for a short to key battery power condition.

With the key in the ON position, use a multimeter to perform the following voltage check on the vehicle harness (VE) side :

From	To	Value
X-9112 pin 3	Chassis ground	There should be no voltage.

- A. If there is voltage, there is a short to key battery power in the DEF/Adblue® tank heating valve Y-9102 circuit. Use the appropriate service manual, if necessary, to locate and repair the shorted conductor.
- B. If there is no voltage, continue to Step 4.

4. Check the DEF/Adblue® tank heating valve Y-9102 for a short to voltage source condition.

Disconnect connector the vehicle harness (VE) from the ECU A-9000 at connector **X-9122**.

With the key in the OFF position, use a multimeter to perform the following continuity check from the vehicle harness (VE) side :

19559-DEF/AdBlue level too low warning is active - Stage 1

NOTE: Because this fault causes inducement, it is necessary to perform the Engine Restart Counter Reset / Unlock Inducement configuration with the Electronic Service Tool (EST) before you return the machine to service. Refer to the engine service manual **Selective Catalytic Reduction (SCR) exhaust treatment - Configure - Engine restart counter reset (10.500)** if necessary.

Context:

For information regarding the functional operation of the Selective Catalytic Reduction (SCR) system, refer to the engine service manual **Selective Catalytic Reduction (SCR) exhaust treatment - Dynamic description (10.500)**. The Engine Control Unit (ECU) A-9000 monitors the level, temperature, and quality of the DEF/AdBlue® fluid. If the level of the fluid falls below **10 %** of full, this fault will occur.

Cause:

The DEF/AdBlue® tank level sensor A-9104 level signal to the ECU A-9000 is less than **10 %** of full.

Possible failure modes:

1. DEF/AdBlue® tank fluid level, too low.
2. Faulty DEF/AdBlue® tank level and temperature sensor A-9104, failed internally.
3. Faulty ECU A-9000, software.

19862-Power stage error in HCU for DEF/AdBlue Back flow line Heater

Context:

The power stage, internal to the Heater Control Unit (HCU) A-9105, for the back-flow and suction line heaters is monitored by the HCU A-9105 for electrical failures. This failure information is transmitted via the Controller Area Network (CAN) from the HCU A-9105 to the Engine Control Unit (ECU) A-9000. If an internal HCU A-9105 power stage failure is detected, this fault will occur.

Cause:

The HCU A-9105 has communicated, via CAN, to the ECU A-9000 that it has experienced an internal power stage failure.

Possible failure modes:

1. Faulty HCU A-9105, hardware or firmware.
2. Faulty ECU A-9000, software.

Solution:

1. As there is no method of field testing or re-flashing the HCU A-9105, replace the HCU A-9105.

Then check to see that this fault has been resolved.

A. If the fault is resolved, return the machine to service.

B. If the fault is not resolved, check the ECU A-9000 for the appropriate software and re-flash, if necessary.

Contents

Front loader and bucket - 82

Arm - 100

FUNCTIONAL DATA

Front loader arm	
Dynamic description	3

SERVICE

Front loader arm	
Remove	6
Install	8

CLICK HERE TO **DOWNLOAD** THE COMPLETE MANUAL

- Thank you very much for reading the preview of the manual.
- You can download the complete manual from: www.heydownloads.com by clicking the link below



- Please note: If there is no response to CLICKING the link, please download this PDF first and then click on it.

CLICK HERE TO **DOWNLOAD** THE COMPLETE MANUAL