

# **SERVICE MANUAL**

---

## **SERVICE MANUAL SECTION**

**CF 500, CF 600 Models Starting September 1, 2007 — ELECTRICAL  
CIRCUIT DIAGRAMS**

**Model: CF 500  
Start Date: 09/01/2007**

**Model: CF 600  
Start Date: 09/01/2007**

**S08332**

**03/18/2008**

CLICK HERE TO **DOWNLOAD** THE COMPLETE MANUAL

- Thank you very much for reading the preview of the manual.
- You can download the complete manual from: [www.heydownloads.com](http://www.heydownloads.com) by clicking the link below



- Please note: If there is no response to CLICKING the link, please download this PDF first and then click on it.

CLICK HERE TO **DOWNLOAD** THE COMPLETE MANUAL

2.5. CIRCUIT NUMBER IDENTIFICATION AND COLOR, P. 5

CIRCUIT NUMBER	COLOR	DESCRIPTION
46	GY	POWER TAKE-OFF WARNING
47	GY	SPEEDOMETER
48	GY	TACHOMETER
49	GY	DIFFERENTIAL LOCK WARNING
50	YL	LIGHT SWITCH FEED
51	YL	DIMMER SWITCH FEED
52	YL	HEADLIGHT HI - BEAM
53	YL	HEADLIGHT LO - BEAM
54	BN	PARKING / MARKER LIGHTS
55	OR	TURN SIGNAL - FEED
56	OR	TURN SIGNAL LIGHTS - LEFT
	YL	TURN SIGNAL LIGHTS - LEFT (BODY BUILDER CONNECTION)
57	OR	TURN SIGNAL LIGHTS - RIGHT
	LTGN	TURN SIGNAL LIGHTS - RIGHT (BODY BUILDER CONNECTION)
58	BN	CLEARANCE / IDENTIFICATION LIGHTS
59	GY	SOLENOID
60	OR	HAZARD LIGHTS
61	GY	AIR SUSPENSION
62	DKBL	PANEL LIGHTS
63	DKBL	COURTESY / DOME LIGHTS
64	YL	FOG / DRIVING LIGHTS
65	OR	CAB REAR FLOOD LIGHTS
66	YL	DAYTIME RUNNING LIGHT
67	GY	OBSTACLE AVOIDANCE / REMOTE SENSOR
68	BN	TAIL LIGHTS
69	BN	LICENSE PLATE LIGHT
70	OR	STOP LIGHTS
	RD	STOP LIGHTS (BODY BUILDER CONNECTION)
71	OR	BACK-UP - LIGHTS
	LTBL	BACK-UP - LIGHTS (BODY BUILDER CONNECTION)
72	OR	TRAILER AUXILIARY FEED - BATTERY
73	LTGN	PWM
74	LTGN	HEATER RECIRCULATION MOTOR
75	LTGN	HEATER BLOWER MOTOR
76	LTGN	AUXILIARY FAN
77	LTGN	AIR CONDITIONER
78	LTGN	MIRRORS - HEATED, MOTORIZED
79	GY	SEAT BELTS
80	BK	SLEEPER BOX RELAY - FEED
81	LTGN	POWER DOOR LOCKS
82	GY	WINDSHIELD WIPER
83	LTGN	POWER WINDOWS
84	LTGN	CIGAR LIGHTER
85	GY	HORN

CHK	DATE	CHANGE	REV	REFERENCE	DRAWN	NAME
CNA1	28AUG07	REVISED AND REDRAWN	B	60785Z	U00JAHF	CIRCUIT DIAGRAM, LCF
					RELEASE NO.	DATE
					59053V	05FEB04
						PART NO.
						AE08055410
						SHEET
						005

Figure 5 Circuit Number Identification and Color

3.3. BATTERY FEEDS, POWER DISTRIBUTION BOX, P. 3

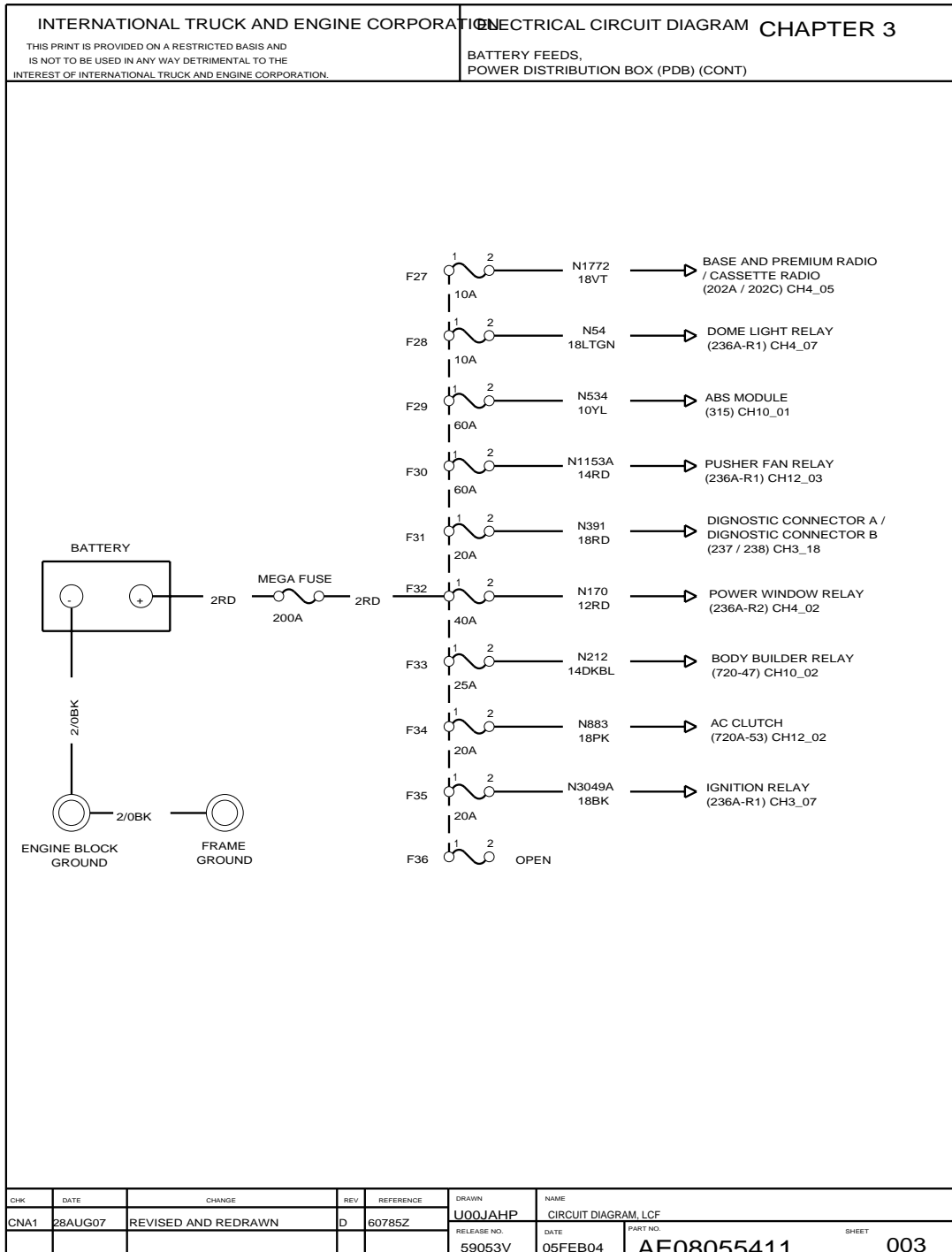

Figure 15 Battery Feeds, Power Distribution Box

3.13. GROUNDS (IP), P. 13

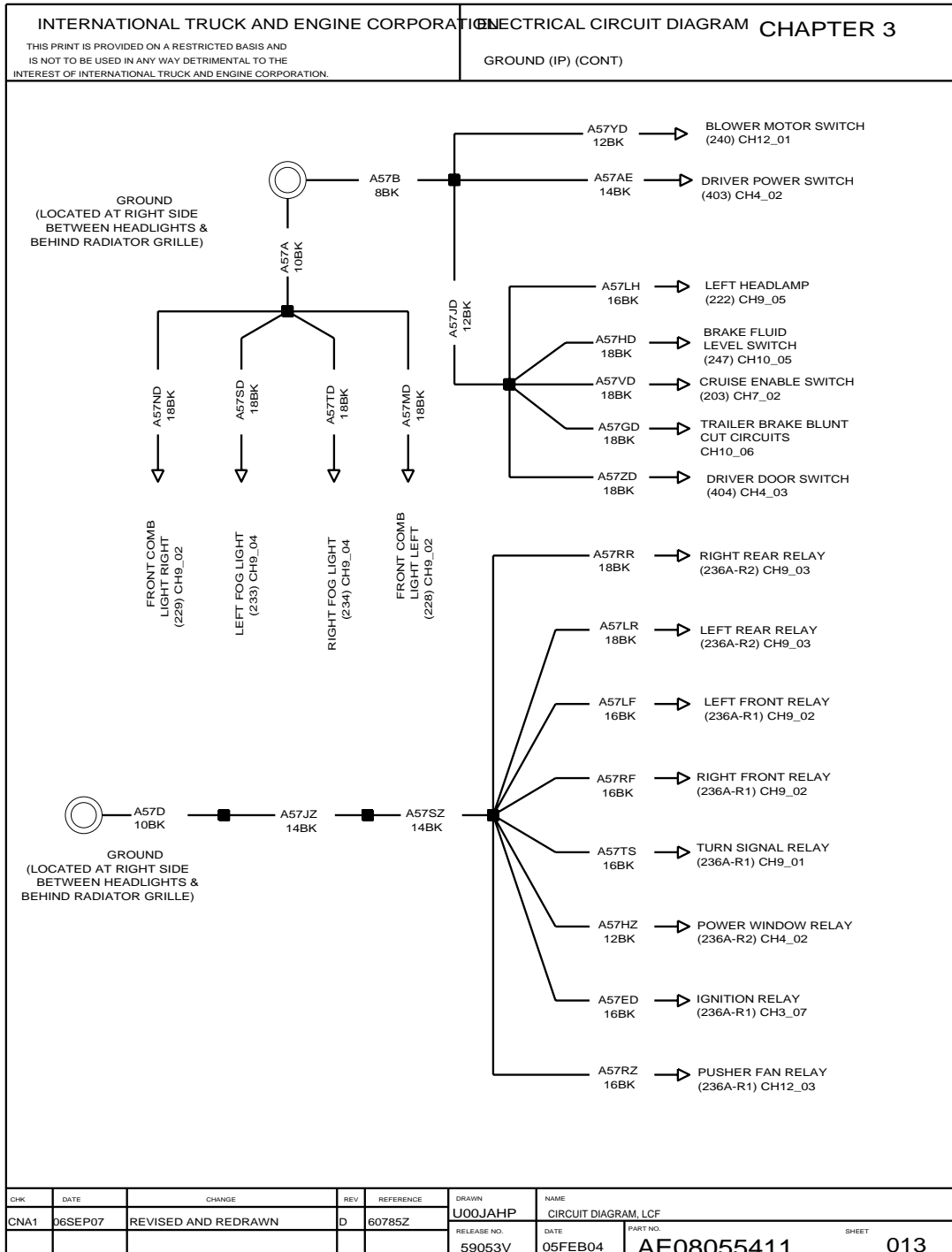

Figure 25 Grounds (IP)

4.5. RADIO, P. 5

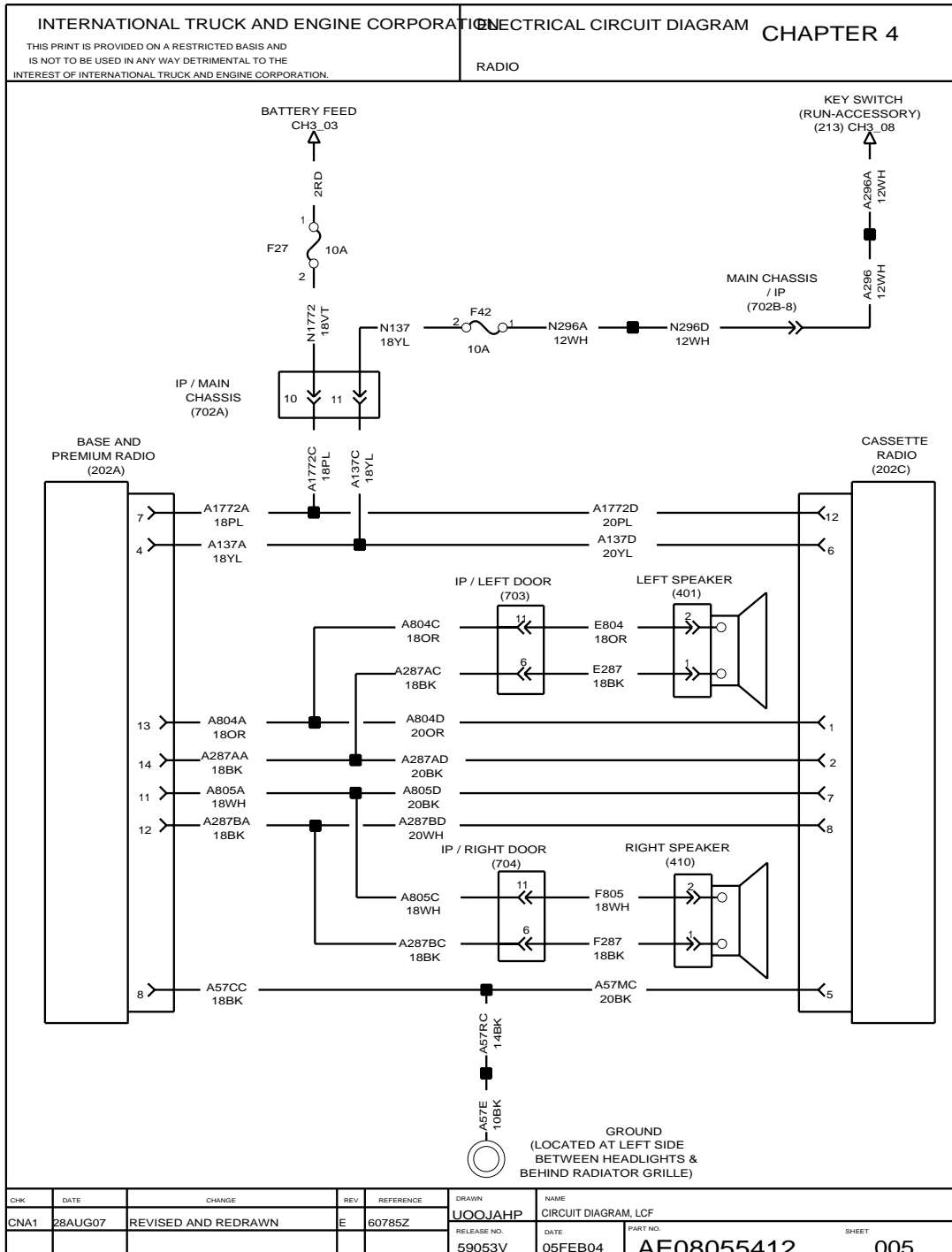

Figure 35 Radio

CLICK HERE TO **DOWNLOAD** THE COMPLETE MANUAL

- Thank you very much for reading the preview of the manual.
- You can download the complete manual from: [www.heydownloads.com](http://www.heydownloads.com) by clicking the link below



- Please note: If there is no response to CLICKING the link, please download this PDF first and then click on it.

CLICK HERE TO **DOWNLOAD** THE COMPLETE MANUAL

7.4. INTERNATIONAL V6 ENGINE SENSOR, P. 4

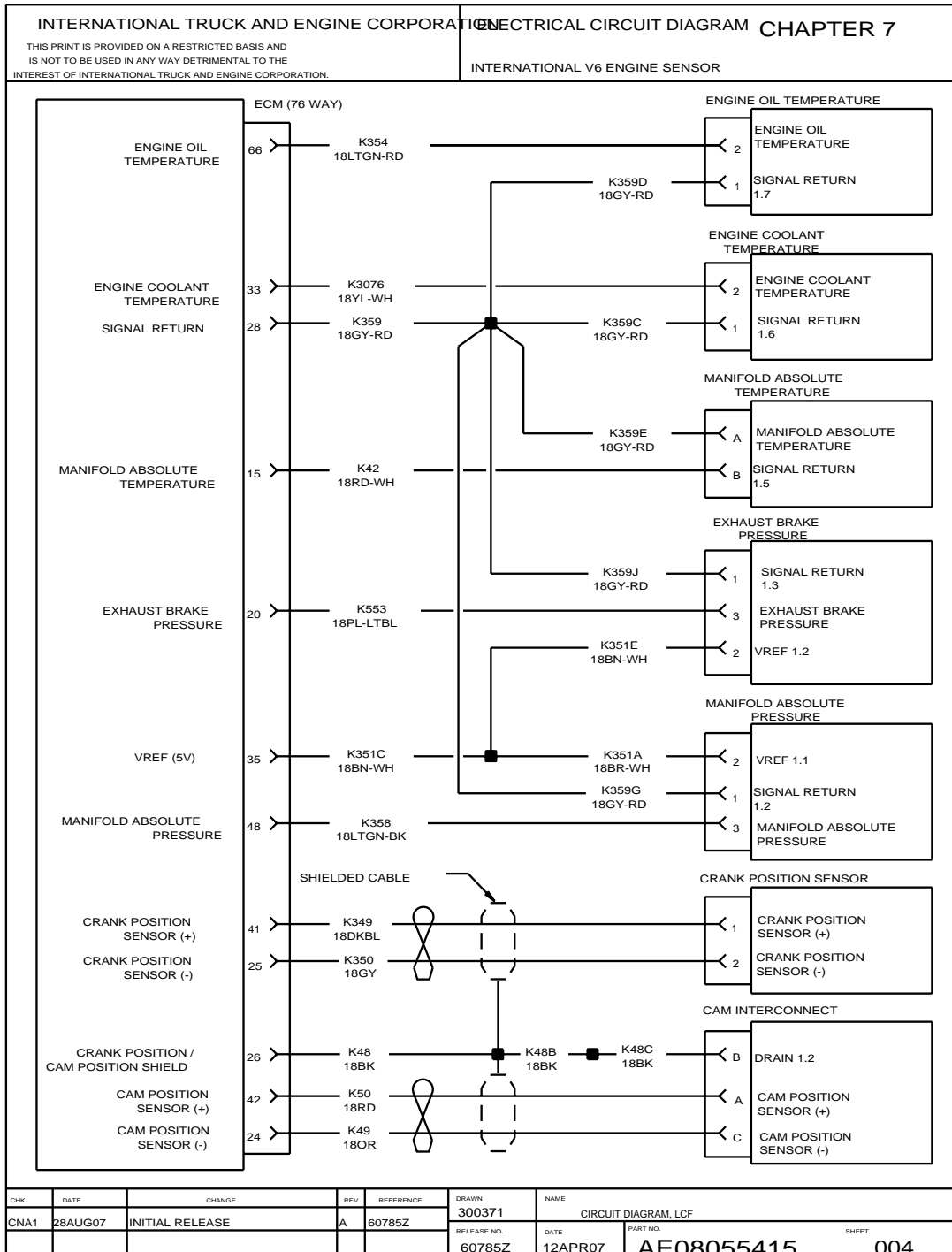

Figure 45 International V6 Engine Sensor

## 9. LIGHT SYSTEMS (CHAPTER 9)

### 9.1. COMBINATION SWITCH A, HAZARD SWITCH, P. 1

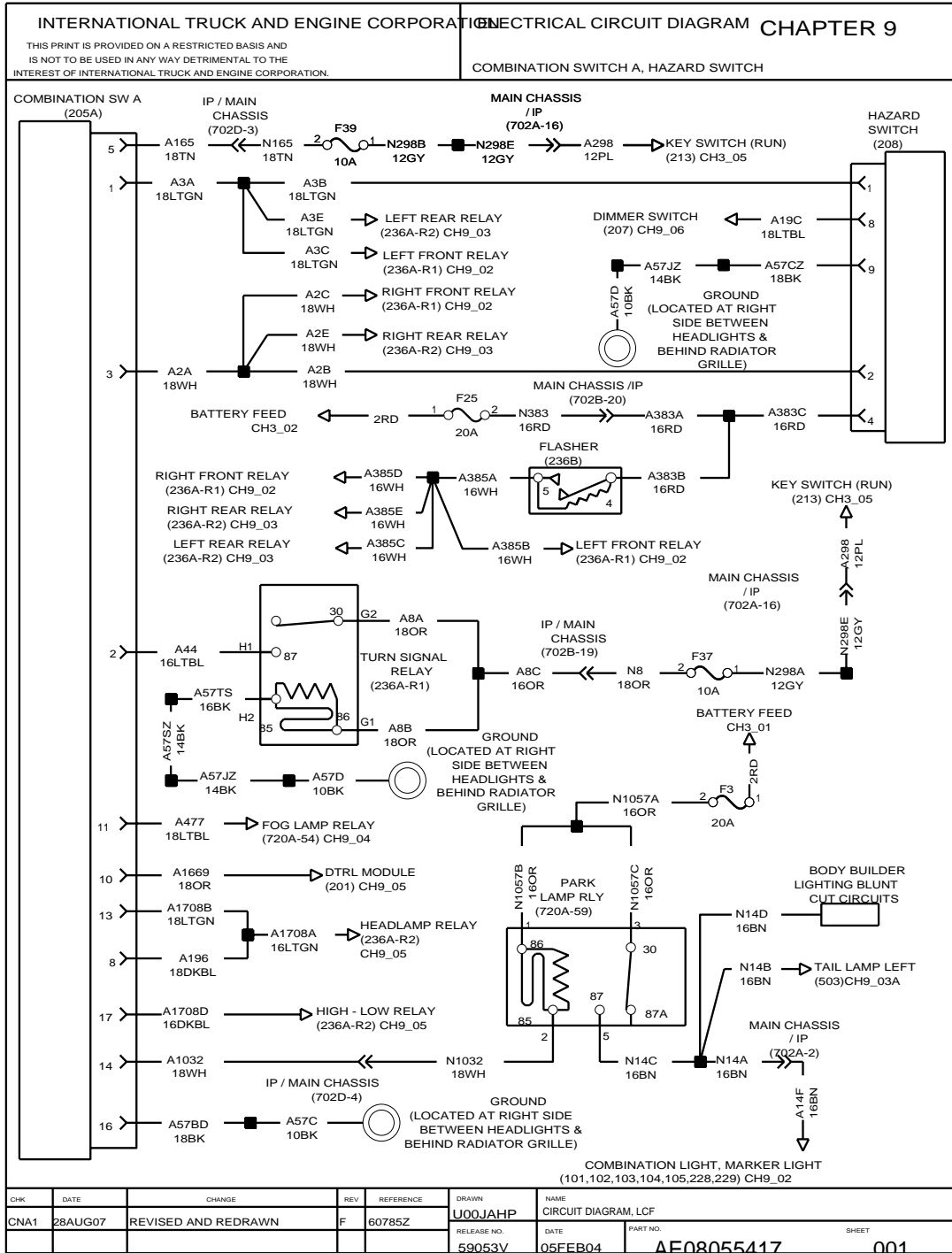

Figure 55 Combination Switch A, Hazard Switch

10.4. BODY BUILDER (EOF), P. 4

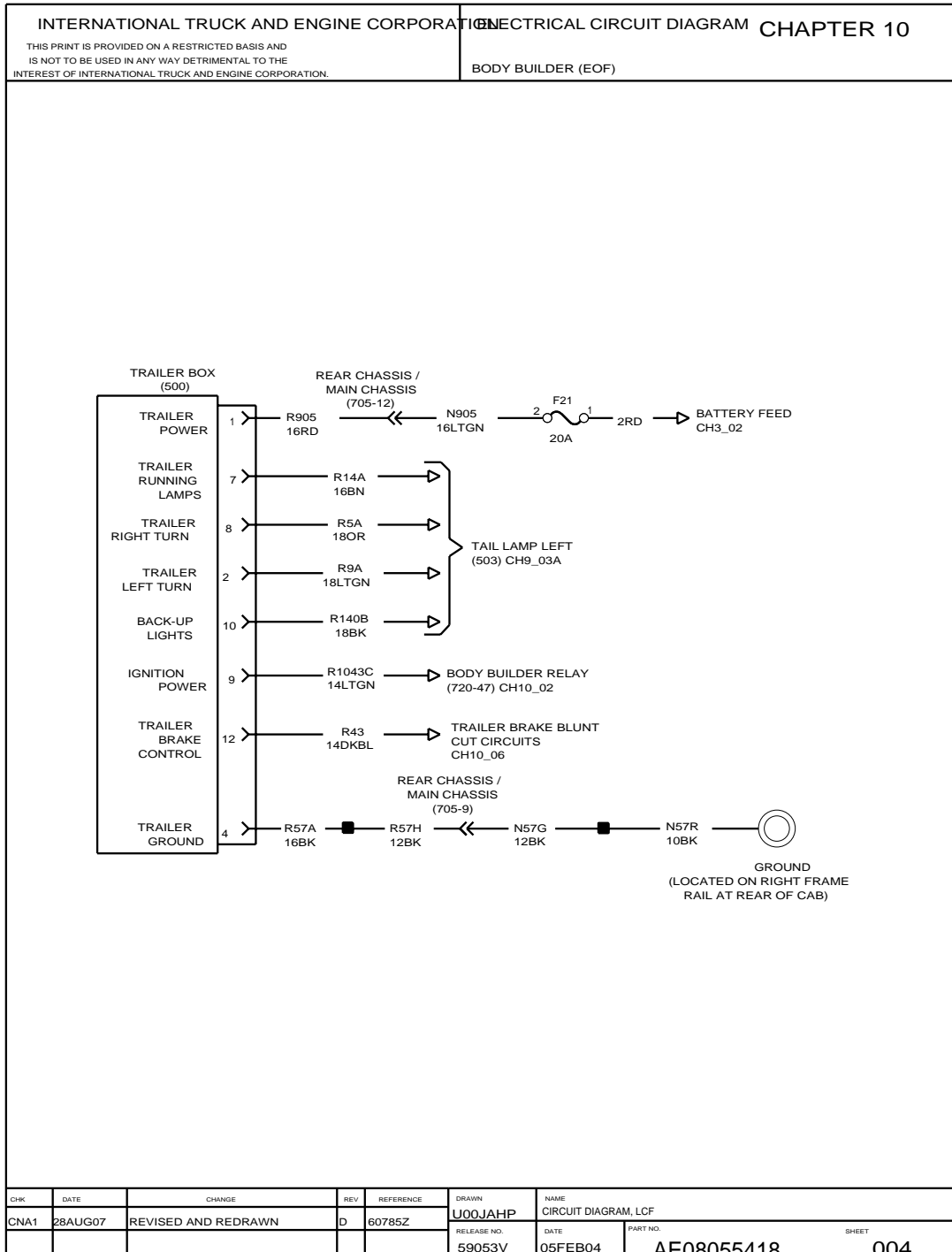

Figure 65 Body Builder (EOF)

13.2. CONNECTOR COMPOSITES (71), (72), (101), (102), P. 2

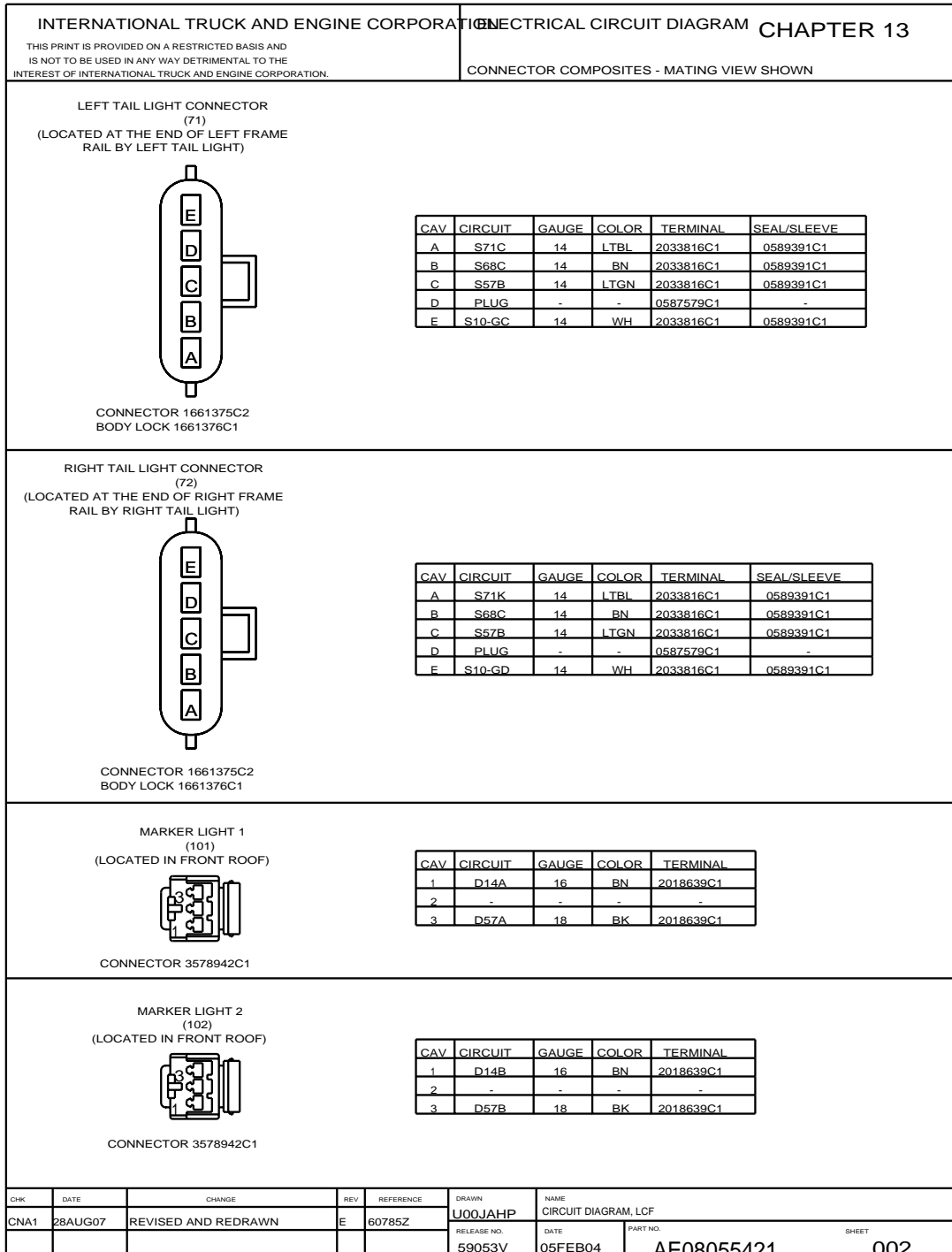

Figure 75 Connector Composites (71), (72), (101), (102)

13.12. CONNECTOR COMPOSITES (236A), P. 12

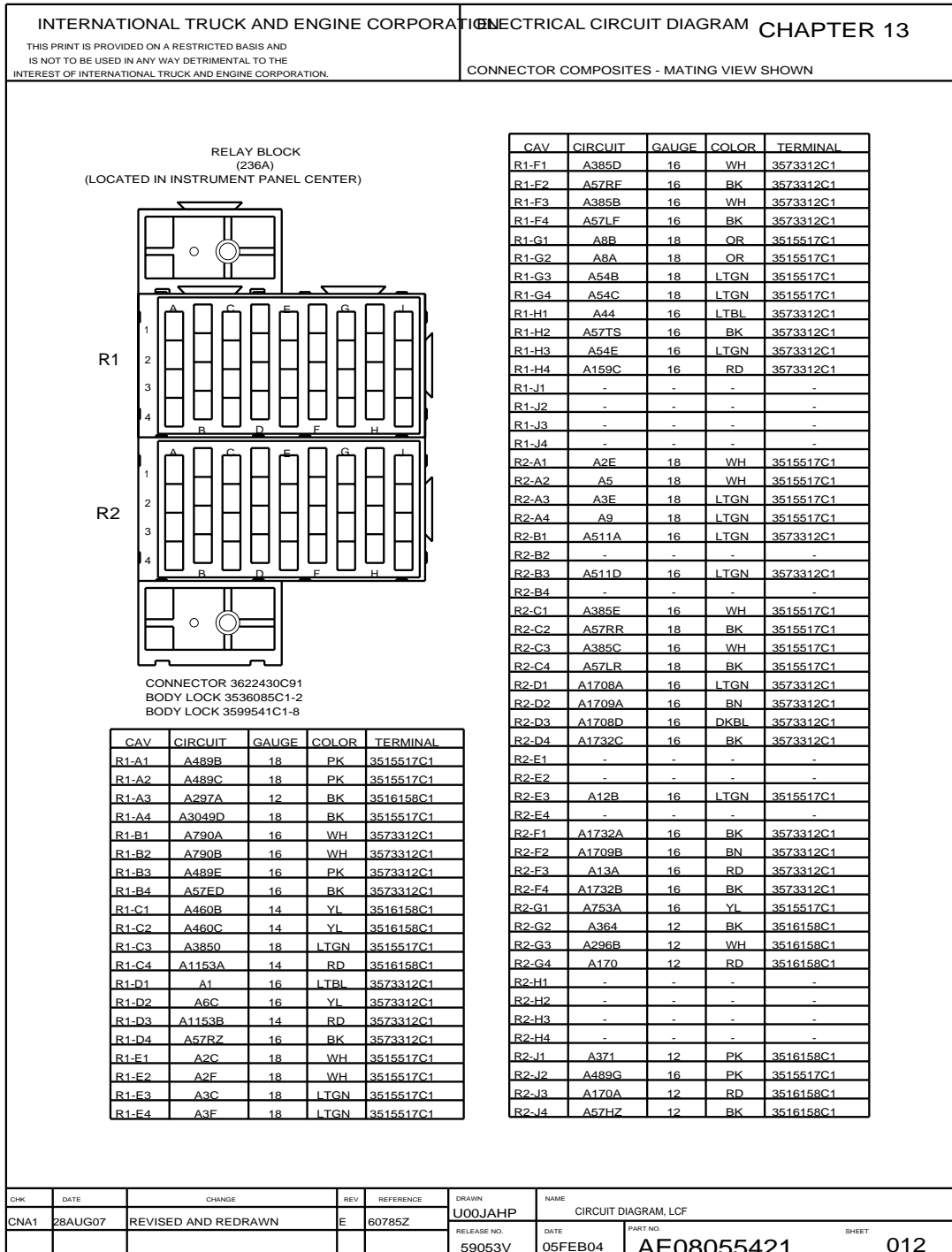

Figure 85 Connector Composites (236A)

13.22. CONNECTOR COMPOSITES (315), P. 22

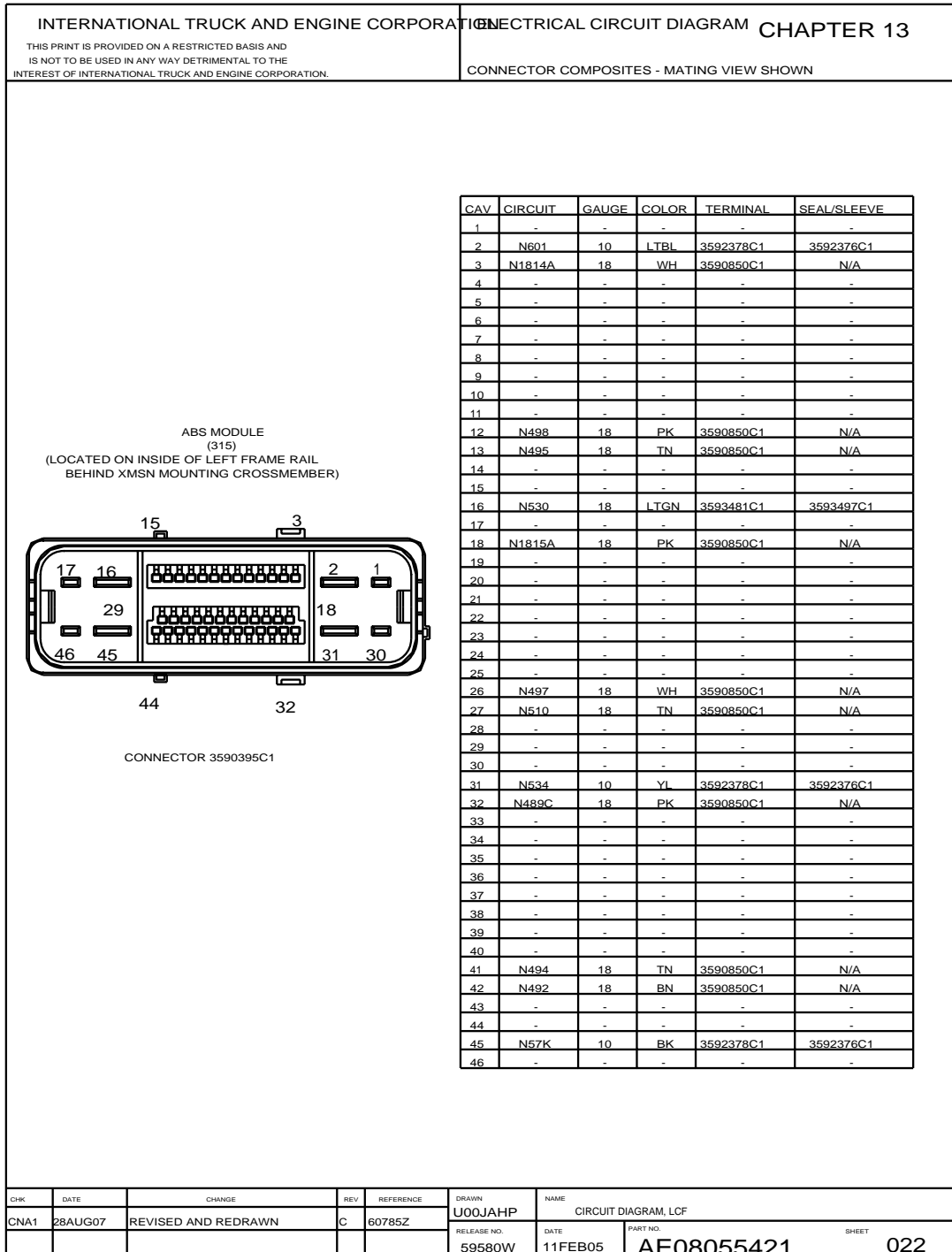

Figure 95 Connector Composites (315)

CLICK HERE TO **DOWNLOAD** THE COMPLETE MANUAL

- Thank you very much for reading the preview of the manual.
- You can download the complete manual from: [www.heydownloads.com](http://www.heydownloads.com) by clicking the link below



- Please note: If there is no response to CLICKING the link, please download this PDF first and then click on it.

CLICK HERE TO **DOWNLOAD** THE COMPLETE MANUAL