

# TELEHANDLERS

**742  
944  
1155**



## **Telehandler**



## **Service Manual**

**#913237**

**Revision B**



CLICK HERE TO **DOWNLOAD** THE COMPLETE MANUAL

- Thank you very much for reading the preview of the manual.
- You can download the complete manual from: [www.heydownloads.com](http://www.heydownloads.com) by clicking the link below



- Please note: If there is no response to CLICKING the link, please download this PDF first and then click on it.

CLICK HERE TO **DOWNLOAD** THE COMPLETE MANUAL

# **Section 101**

## **GENERAL INFORMATION AND SPECIFICATIONS**

### **Mustang Telehandler**

**LIFTING PERFORMANCE**

**Maximum Lift Capacity:**

742	.....	.7000 lbs. (3175 kg)
744	.....	.7000 lbs (3175 kg)
944	.....	.9000 lbs (4080 kg)
1155	.....	.11,000 lbs (4990 kg)

**Maximum Lift Height:**

742 ( <i>Low Boom</i> )	.....	.41'-9" (12.7 m)
742 ( <i>High Boom</i> )	.....	.42'-3" (12.9 m)
744	.....	.44'-4" (13.5 m)
944 ( <i>Low Boom</i> )	.....	.44'-0" (13.4 m)
944 ( <i>High Boom</i> )	.....	.44'-4" (13.5 m)
1155 ( <i>Low Boom</i> )	.....	.55"-1" (16.8 m)
1155 ( <i>High Boom</i> )	.....	.55'-5" (16.9 m)

**Capacity at Maximum Lift Height:**

742 ( <i>Low Boom</i> )	.....	.7000 lbs. (3171 kg)
742 ( <i>High Boom</i> )	.....	.7000 lbs. (3171 kg)
744	.....	.6000 lbs. (2721 kg)
944 ( <i>Low Boom</i> )	.....	.7000 lbs. (3175 kg)
944 ( <i>High Boom</i> )	.....	.7000 lbs. (3175 kg)
DL10H-44	.....	.8000 lbs. (3624 kg)
Outrigger Up		
1155 ( <i>Low Boom</i> )	.....	.5000 lbs. (2267 kg)
1155 ( <i>High Boom</i> )	.....	.5000 lbs. (2267 kg)
Outrigger Down		
1155 ( <i>Low Boom</i> )	.....	.5500 lbs. (2495 kg)
1155 ( <i>High Boom</i> )	.....	.5500 lbs. (2495 kg)

**Forward Reach at Maximum Lift Height:**

742 ( <i>Low Boom</i> )	.....	.2'-6" (762 mm)
742 ( <i>High Boom</i> )	.....	.2'-9" (840 mm)
744	.....	.3'-4" (1016 mm)
944 ( <i>Low Boom</i> )	.....	.3'-0" (914 mm)
944 ( <i>High Boom</i> )	.....	.3'-4" (1016 mm)
1155 ( <i>Low Boom</i> )	.....	.5'-9" (1753 mm)
1155 ( <i>High Boom</i> )	.....	.6'-7" (2007 mm)

## STEP 22

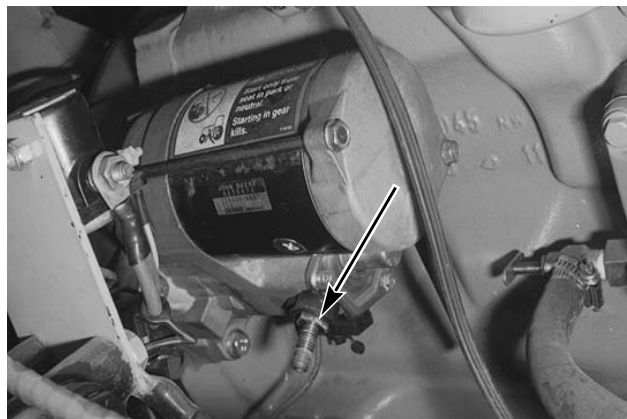

G1366MP

Remove the battery and starter relay power cables from the starter solenoid.

## STEP 23

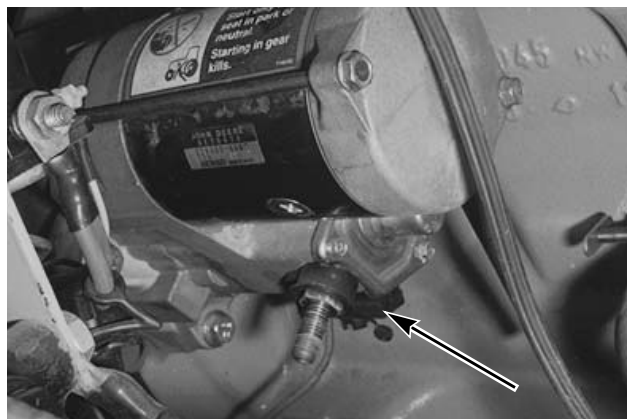

G1366MP

Loosen the terminal bolt and remove the starter relay wire from the starter solenoid.

## STEP 24

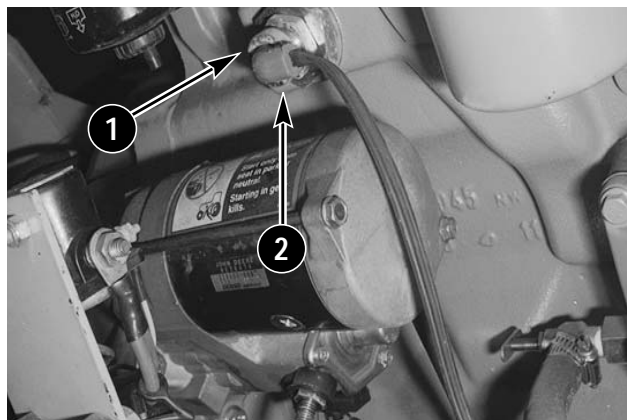

G1366MP

Remove the retaining ring (1) and remove the block heater plug (2).

## STEP 25

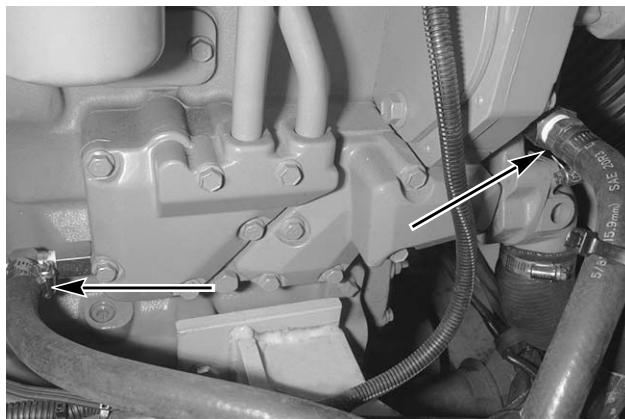

G1159MP

If equipped, place a container under the hoses and remove the heater hoses from the engine.

**NOTE:** *There is fluid trapped in the hoses and engine that will drain when the hoses are removed.*

## STEP 26



G1158MP

If equipped, remove the hose adapter from the water pump.

## STEP 65

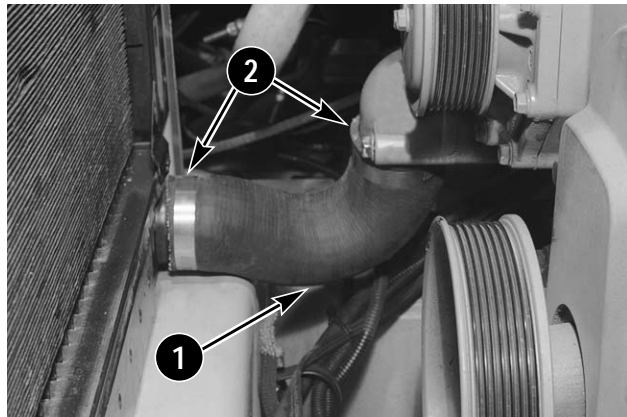

G1380MP

Install the lower radiator hose (1) between the water pump and the radiator. Tighten the hose clamps (2).

## STEP 66

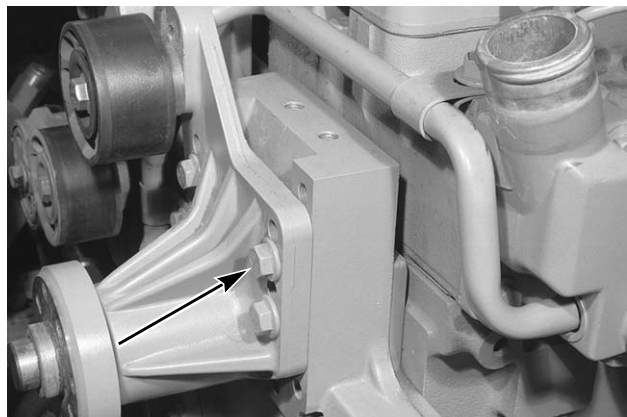

G1396MP

Use the four M10 x 35 Grade 10.9 flange head bolts to install the fan bearing. Tighten the bolts to a torque of 50 to 56.5 lb ft (68 to 77 Nm).

## STEP 67

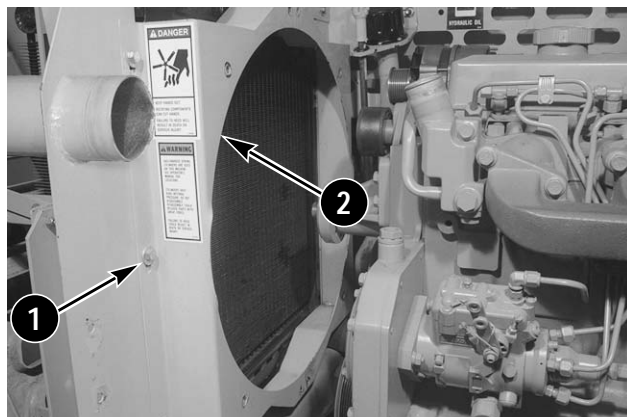

G1379MP

Use the six 5/16 x 3/4 inch Grade 5 bolts (1) and washers to install the fan shroud (2) on the radiator. Tighten the bolts to a torque of 12 to 13.5 lb ft (16.4 to 18.4 lb ft).

PRINTED IN U.S.A.

## STEP 68

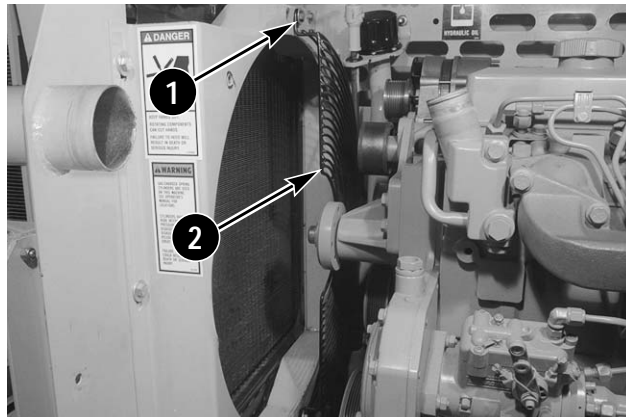

G1378MP

Use the four 5/16 x 3/4 inch Grade 5 bolts (1) and washers to install the LH fan guard on the fan shroud. Tighten the bolts to a torque of 12 to 13.5 lb ft (16.4 to 18.4 Nm).

## STEP 69

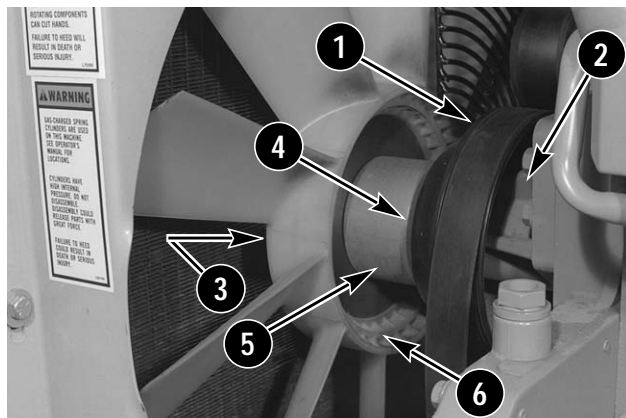

G1377MP

Hold the belt (1) over the fan bearing (2). Use the four M8 x 70 Grade 8.8 bolts (3) and washers to install the fan pulley (4), spacer (5) and fan (6) on the fan bearing (2). Hold the spacer (5) from turning and tighten the four bolts to a torque of 20 to 22.5 lb ft (27 to 31 Nm).

## PARK BRAKE CIRCUIT TROUBLESHOOTING

The park brake switch is OFF, but the brakes do not release.  
Does the frame leveling operate correctly?

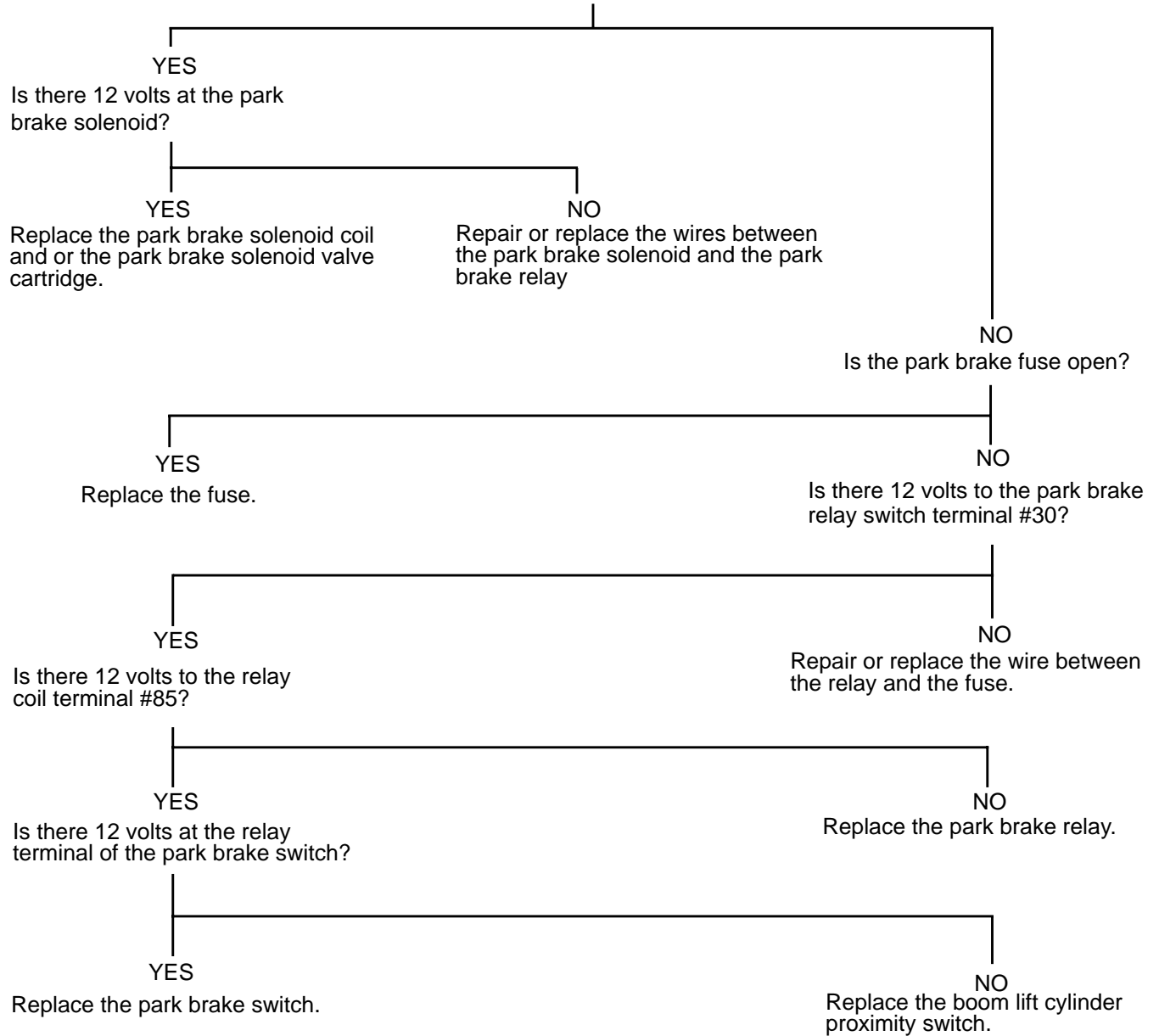

(Electrical Schematic For Serial Numbers Listed)

742 High Boom thru serial number 20046  
742 Low Boom thru serial number 25043  
944 High Boom thru serial number 30022  
944 Low Boom thru serial number 35014  
1155 High Boom thru serial number 40024  
1155 Low Boom thru serial number 45014

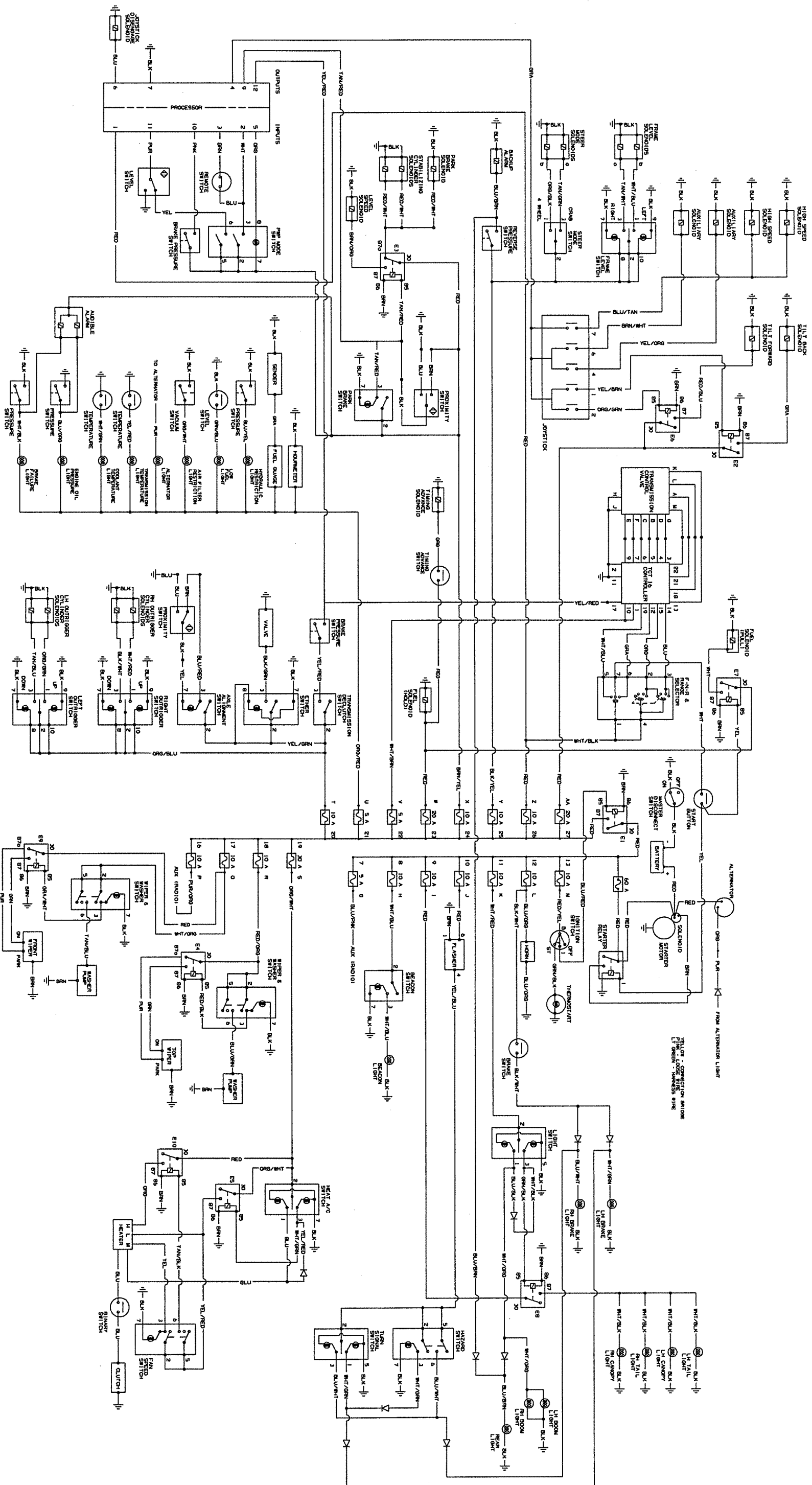

## STEP 17

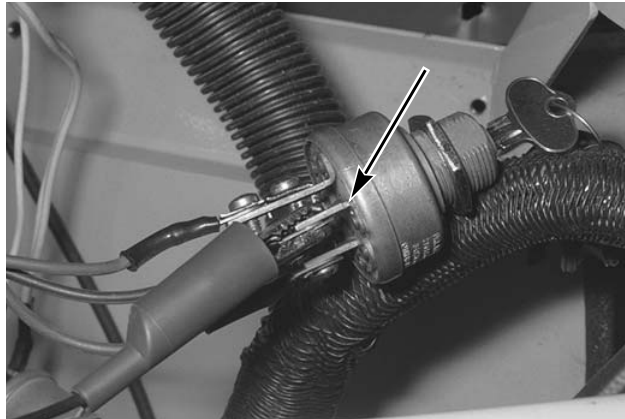

G1285MP

Connect the positive (+) test lead to the induction heater (green/black wire) terminal of the key switch. Turn and hold the key switch in the induction heater position. The multimeter should read 12 to 13 volts.

If there is no voltage, replace the key switch.

If there is 12 to 13 volts, but the engine is still difficult or won't start in cold weather, replace the engine induction heater.

**NOTE:** *Induction heater used on machines equipped with a Perkins Engine only.*

## STEP 18



G1281MPR

Connect the positive (+) test lead to the white wire terminal of the starter switch. Turn the key switch to the ON position. With the transmission lever in neutral the multimeter should read 12 to 13 volts.

If there is no voltage, check the fuse. If the fuse is not open, replace the transmission lever/switch assembly.

If there is 12 to 13 volts, proceed to the next step.

## STEP 19

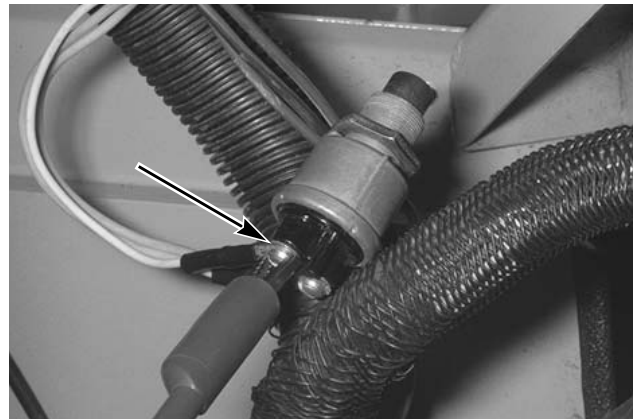

G1282MP

Connect the positive (+) test lead to the yellow wire terminal of the starter switch. Place the transmission lever in the neutral position, turn the key switch to the ON position and press the starter switch button. The multimeter should read 12 to 13 volts.

If there is no voltage, replace the starter switch.

If there is 12 to 13 volts, but there was no voltage at the starter relay ignition terminal (Step 11), repair or replace the wire between the switch and relay.

## STEP 20

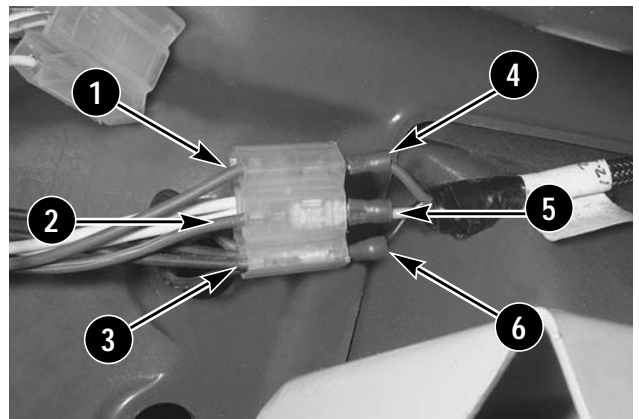

G1185MP

If equipped with a front window,

Locate the six terminal connector on the right side of the dash with the green (1), purple (2), black (3) and white wires.

Insert the red (4), yellow (5) and black (6) wires of the front wiper harness into the green (1), purple (2), and black (3) wire terminals of the connector as shown.

## STEP 55

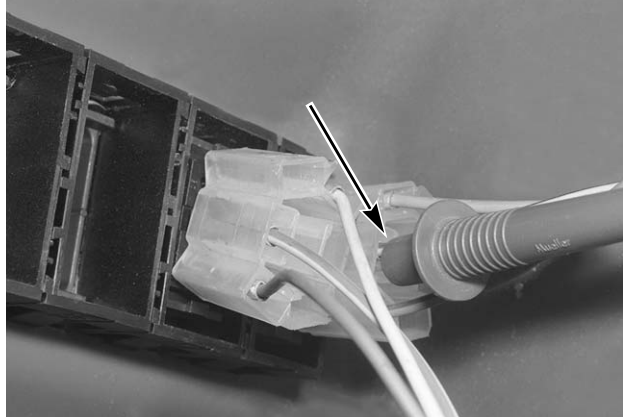

G1296MP

Connect the positive (+) test lead to the black/yellow wire terminal of the steer mode switch located on the left side of the dash. With the key switch in the ON position the multimeter should read 12 to 13 volts.

If there is no voltage, repair or replace the black/yellow wire between the switch and the fuse panel.

If there is 12 to 13 volts proceed to the next Step.

## STEP 56

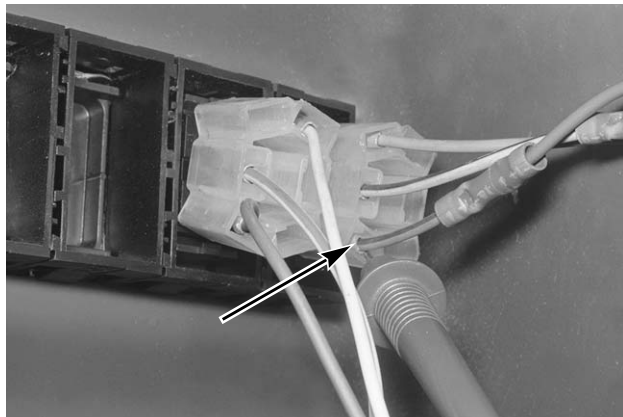

G1298MP

Connect the positive (+) test lead to the orange/black wire terminal of the steer mode switch. With the key switch in the ON position and the steer mode switch in the 4-WHEEL STEER position, the multimeter should read 12 to 13 volts.

If there is no voltage replace the steer mode switch.

If there is 12 to 13 volts, but no voltage in Step 52, repair or replace the orange/black wire between the switch and the solenoid valve.

## STEP 57

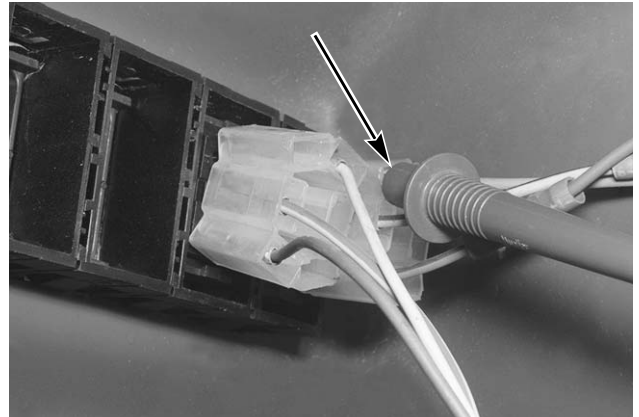

G1297MP

Connect the positive (+) test lead to the tan/green wire terminal of the steer mode switch. With the key switch in the ON position and the steer mode switch in the CRAB STEER position, the multimeter should read 12 to 13 volts.

If there is no voltage, replace the steer mode switch.

If there is 12 to 13 volts, but no voltage in Step 53, repair or replace the tan/green wire between the switch and the solenoid valve.

## STEP 58

See Steps 20, 21 and 22 for instructions to install the dash cover.

## AXLE ALIGNMENT CIRCUIT TESTS

## STEP 59

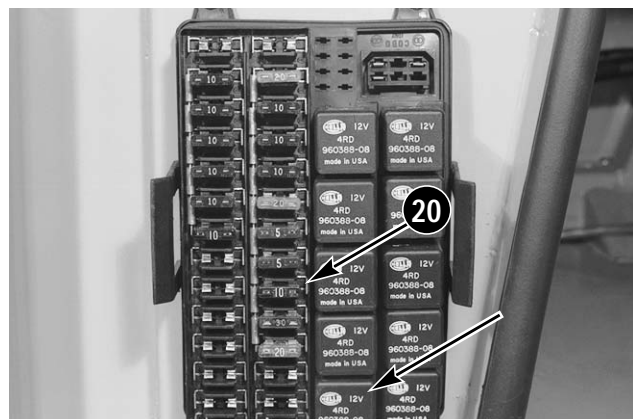

G1353MP

Check the axle alignment fuse (#20). Test the power to the fuse (Step 4) and the ignition relay (Steps 5 and 6).

## BATTERY REMOVAL AND INSTALLATION

### BATTERY REMOVAL



### WARNING

BATTERY ACID CAUSES SEVERE BURNS. Batteries contain sulfuric acid. Avoid contact with skin, eyes or clothing. Antidote: EXTERNAL - flush with water. INTERNAL - Drink large quantities of water or milk. Follow with milk of magnesia, beaten egg or vegetable oil. Call a physician immediately.

EYES - Flush with water for 15 minutes and get prompt medical attention. BATTERIES PRODUCE EXPLOSIVE GASES. Keep sparks, flame and cigarettes away. Ventilate when charging or using in enclosed space. Always shield eyes when working near batteries. KEEP OUT OF REACH OF CHILDREN.



### WARNING

When working around storage batteries, remember that all of the exposed metal parts are "live". Never lay a metal object across the terminals because a spark or short circuit will result.

#### STEP 1

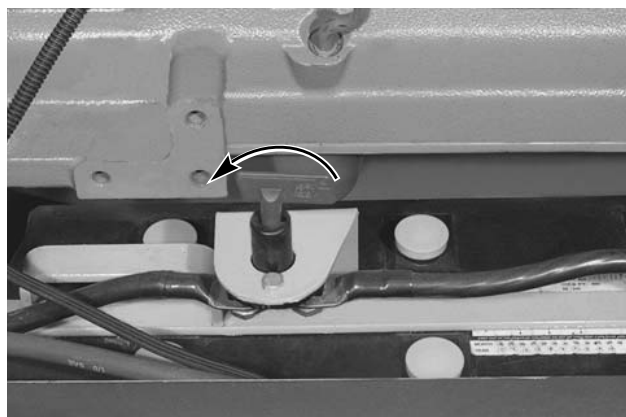

G1191MP

Turn the master disconnect switch key counterclockwise to the OFF position. Remove the key from the switch.

#### STEP 2

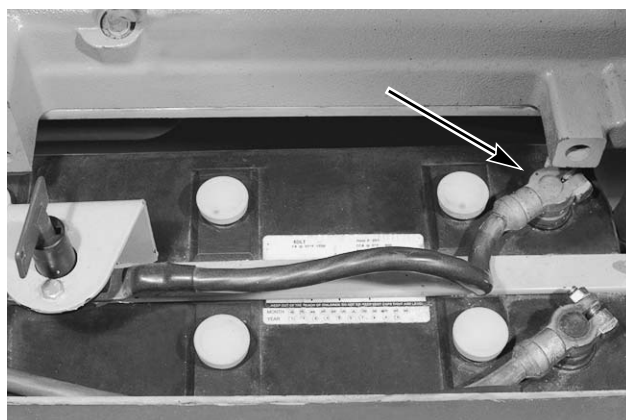

G1351MP

Remove the negative (-) battery cable from the battery.



### WARNING

Always remove the negative (-) battery cable first so you do not cause a spark at the battery. A spark can cause the battery to explode and cause personal injury or damage to the machine.

Remove the positive (+) battery cable from the battery.

## STEP 23



G1760MP

Separate the steering control valve from the steering column and remove from the machine.

## STEERING CONTROL VALVE INSTALLATION

## STEP 24



G1760MP

Position the steering control valve and steering column together. Make sure the fittings are in the proper position for hose installation.

## STEP 25

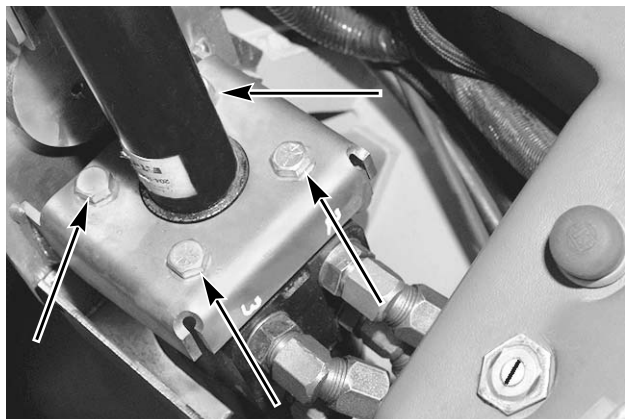

G1761MP

Install the four bolts through the steering column and into the steering control valve and tighten.

## STEP 26

Remove the caps and plugs from the hoses and fittings.

## STEP 27

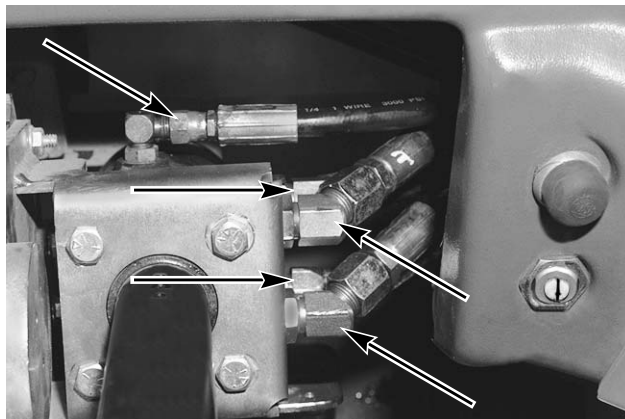

G1762MP

Reconnect the hydraulic hoses to the fittings on the steering control valve, as marked earlier.

## STEP 11

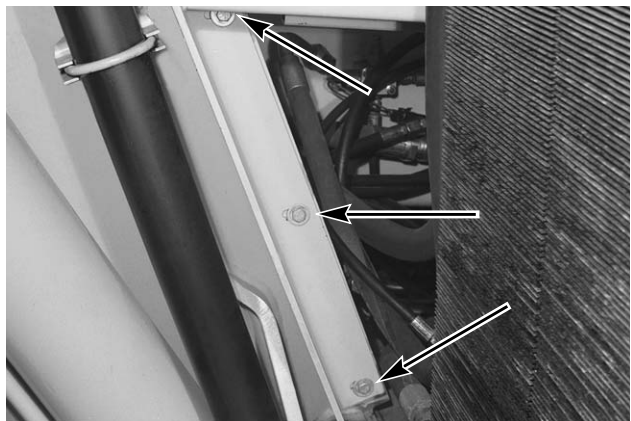

G1419MP

Remove the three front and three rear bolts from the engine and transmission covers hinge mounting bracket and remove the bracket from the machine.

## STEP 12

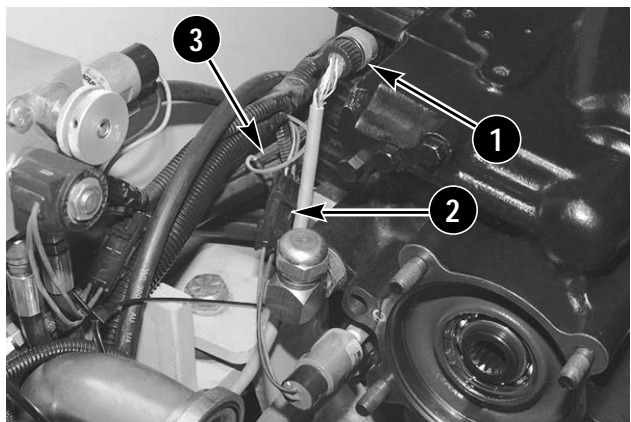

G1420MP

Remove the wires from the transmission control solenoids (1), the reverse pressure switch (2) and the transmission temperature switch (3).

## STEP 13

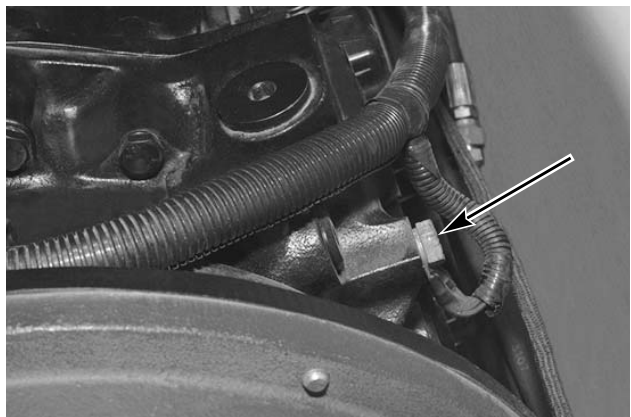

G1421MP

Remove the bolt from the ground wires on the left side of the transmission.

## STEP 14

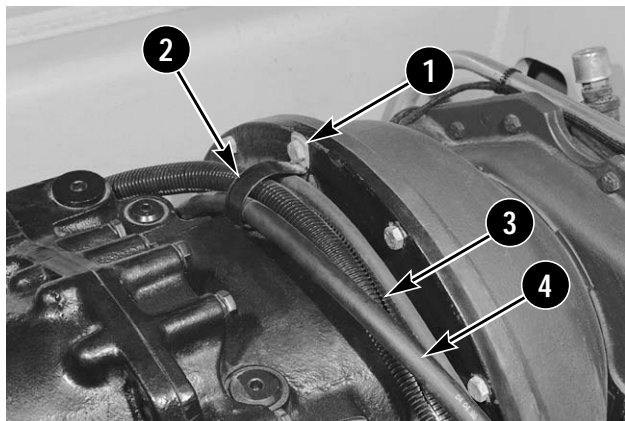

G1422MP

Remove the bolt (1) and P-clamp (2) from the transmission to transfer case mounting flange. Remove the wire harness (3) and fuel hoses (4) from the P-clamp.

## STEP 15

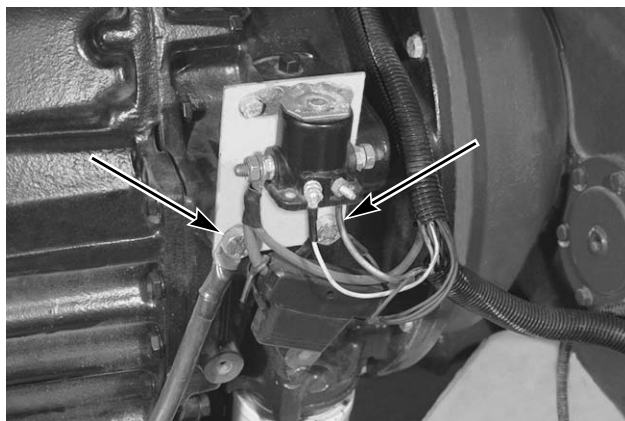

G1423MP

Remove the two bolts from the starter relay mount.

## STEP 49

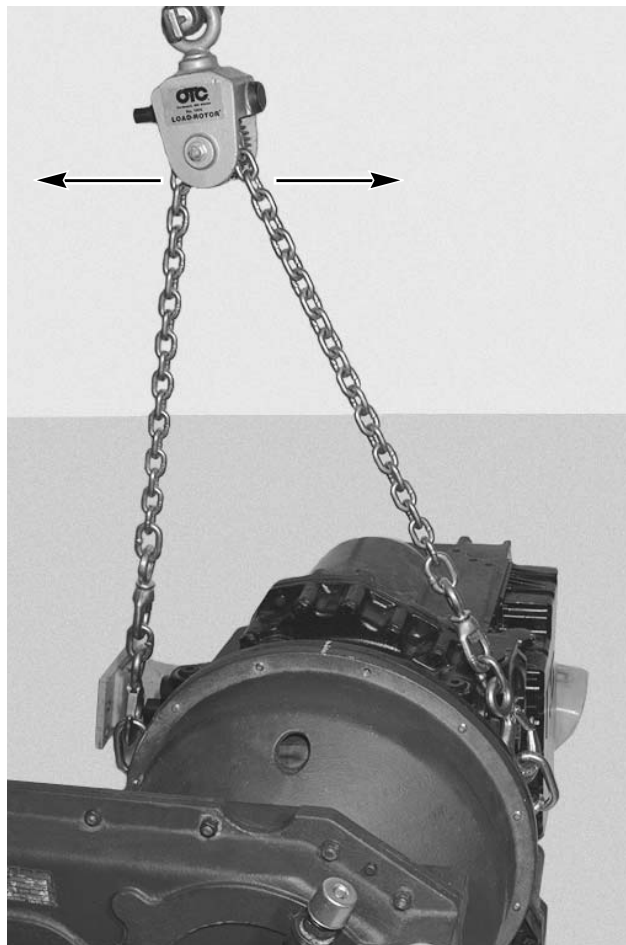

G1496MP

To find the balance point for the transmission/transfer case assembly, raise the hoist 2 inches and adjust the load rotor.

## STEP 50

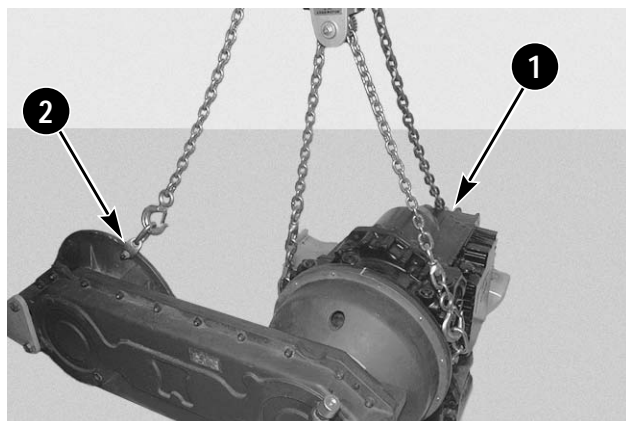

G1497MP

Lower the transmission/transfer case assembly onto the support blocks and install stabilizer chains between the hoist and the hydraulic pump mounting stud (1) and the hoist and engine bell housing (2).

## STEP 51

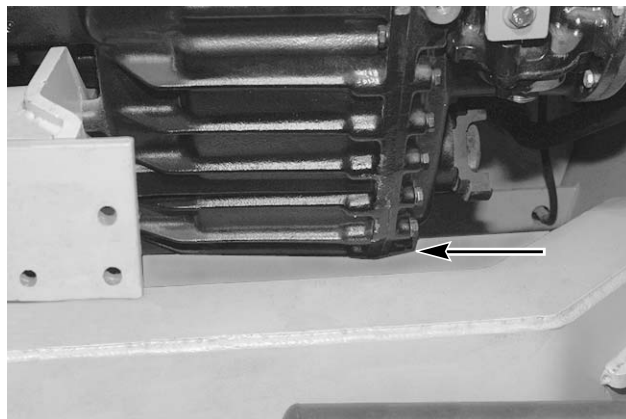

G1443MP

Raise the transmission/transfer case assembly high enough for the bottom of the transmission to clear the top of the right side frame rails. Move the assembly into position over the three frame to transmission and transfer case mounting brackets.

## STEP 52

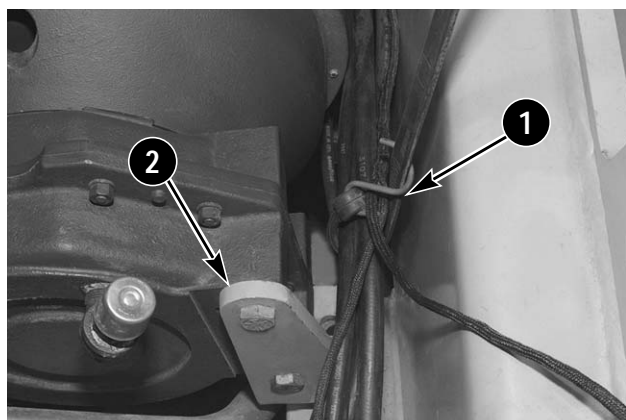

G1439MP

Hold the wire harnesses and hoses (1) on the left side of the transmission clear of the transmission and transfer case mounting brackets (2). Slowly lower the the assembly onto the frame brackets.

## TRANSFER CASE REPAIR

### TRANSFER CASE DISASSEMBLY

#### STEP 1



G1441MP

Remove the transmission and transfer case from the machine. See Section 501, Transmission and Transfer Case Removal section of this manual for the correct removal procedure.

#### STEP 2

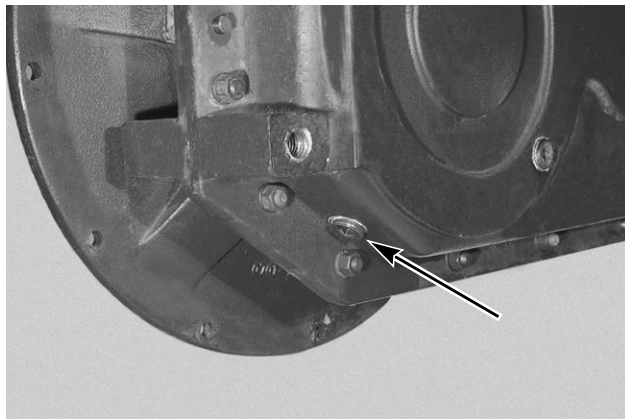

G1492MP

Remove the bottom plug and drain the fluid from the transfer case.

#### STEP 3

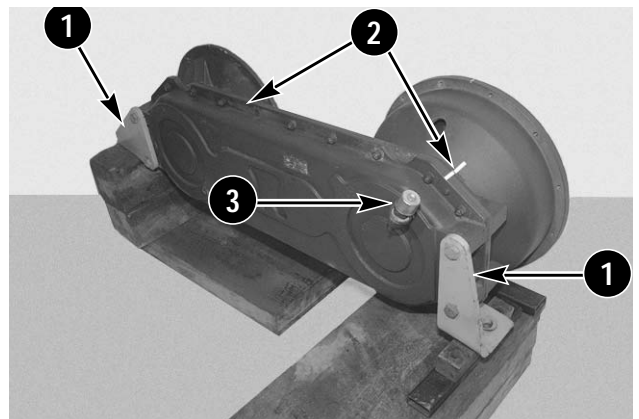

G1450MP

Remove the two mounting brackets (1) from the transfer case. Use a dye marker to mark the position of each bell housing (2) in relation to the gear case.

Remove the breather and elbow fitting (3) from the front housing.

#### STEP 4

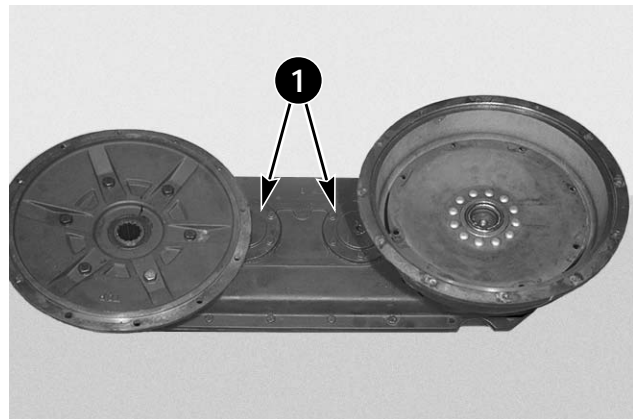

G1491MP

Place the transfer case on a level work surface with the input and output shafts facing up. Use a dye marker to mark the location of the two bearing retainers (1) in relation to the housing for assembly reference.

**NOTE:** Some fluid trapped inside the transfer case may leak out the breather hole.

# Mustang Telehandler

# TRANSFER CASE

## STEP 45

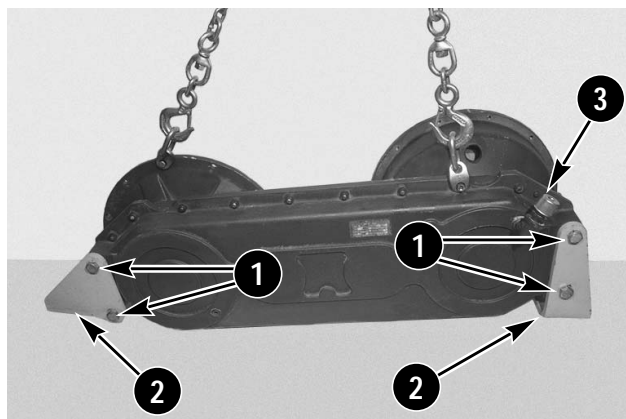

G1490MP

Use the four 5/8 NC x 1 1/4 inch Grade 5 bolts (1) to install the transfer case mounting brackets (2) on the front housing. Tighten the bolts (1) to a torque of 160 to 180 lb ft (215 to 245 Nm).

Install the elbow fitting and breather (3) on the front housing.

## STEP 46

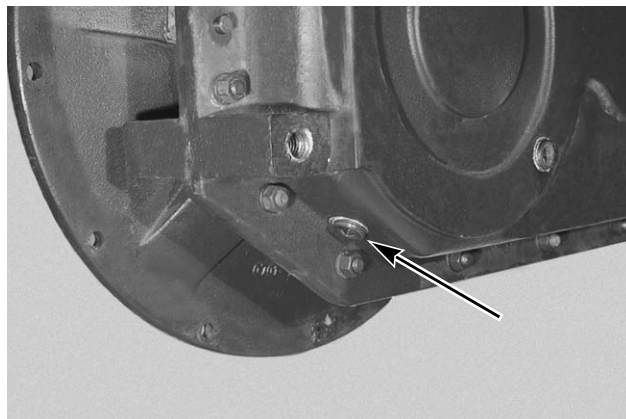

G1492MP

Install and tighten the drain plug.

## STEP 47

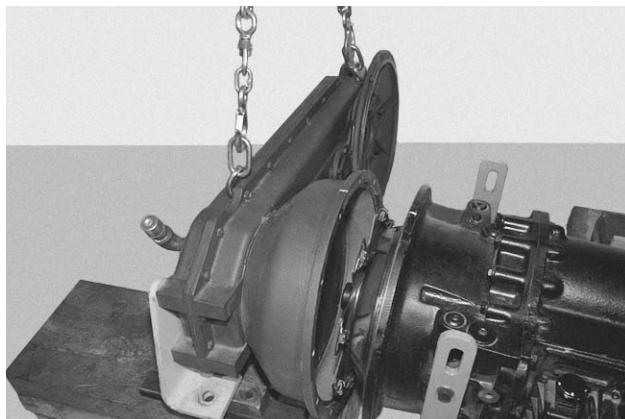

G1451MP

See Section 501, Transmission and Transfer Case Installation section of this manual for the correct procedure to install the transfer case on the transmission and to install the transmission/transfer case assembly into the machine.

## STEP 48

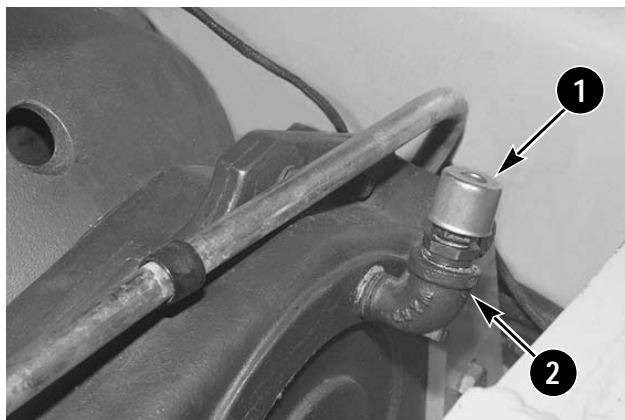

G1503MP

Remove the breather cap (1) from the top of the transfer case. Fill the case through the breather elbow adapter (2) with 2.75 quarts (2.6 L) of the recommended fluid.

Install and tighten the breather cap.

## STEP 32

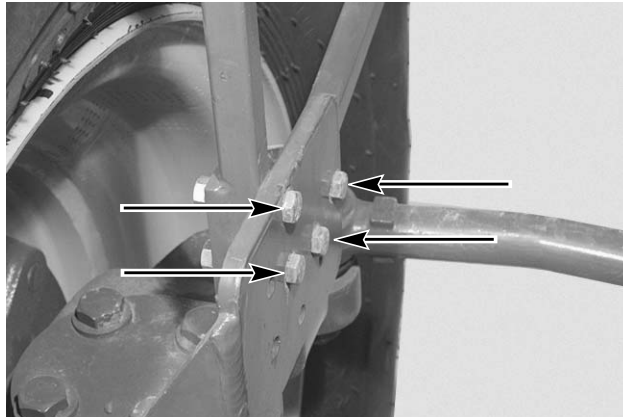

G1728MP

Reinstall the fenders to the fender brackets. Tighten the bolts and nuts.

## STEP 33

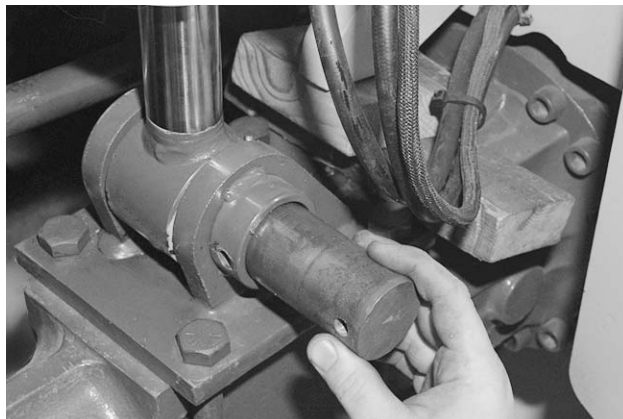

G1738MP

Using a pry bar, extend the stabilizer cylinder rod enough to install the lower pivot pin. Be sure to align the retainer bolt holes.

## STEP 34

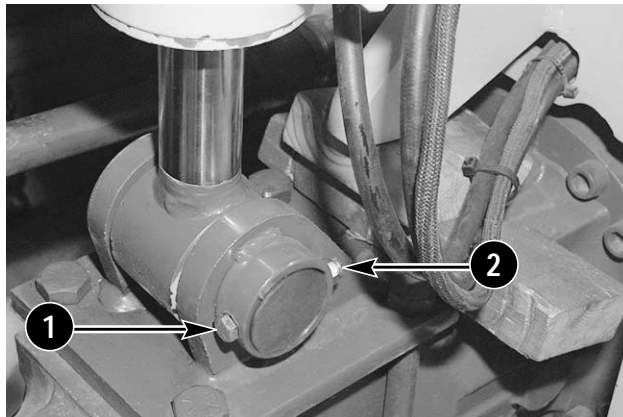

G1739MP

Reinstall the retainer bolt (1) and nut (2) in the lower pivot pin and tighten.

## STEP 35



G1245MP

Start the engine, apply the park brake. Move the steer mode switch to the 4-wheel steering position. Turn the steering wheel in one direction until the wheels reach their travel limits and back the other way to its travel limit. Repeat this procedure several times until the air is removed from the circuit.

## STEP 36

Shut down the engine. Check for leaks. Correct any leakage found. Check fluid level, add fluid if needed.

## STEP 37

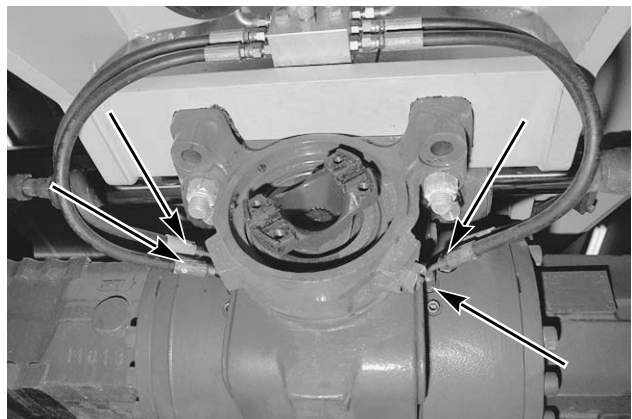

G1747MP

Reconnect the four hydraulic hoses to the brake connectors.

## STEP 38

Remove the caps and plugs from the hydraulic fittings and hoses.

## STEP 39

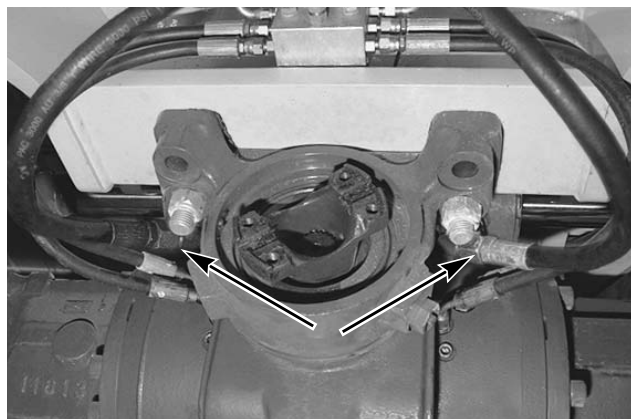

G1759MP

Reconnect the two hoses to the steering cylinder.

**NOTE:** When performing Steps 40 and 41 it may be necessary to jack one rear wheel clear of the surface in order to align the driveshaft yokes. Use Loctite 271 Thread Lock (or equivalent) on the threads of the driveshaft mounting bolts.

## STEP 40

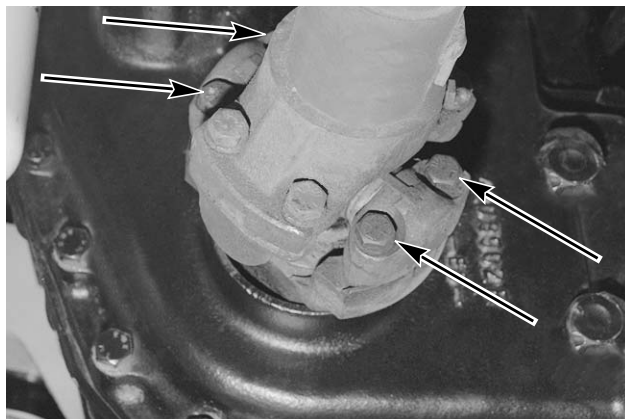

G1743MP

Reinstall the driveshaft to the transmission using the four bolts and lock washers.

## STEP 41

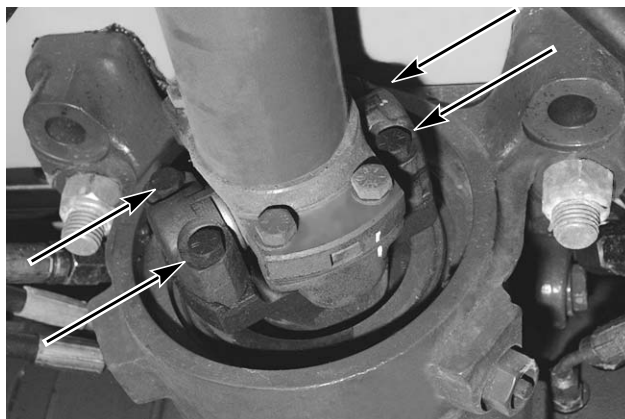

G1742MP

Reinstall the driveshaft to the front axle using the four bolts and lock washers.

## STEP 42

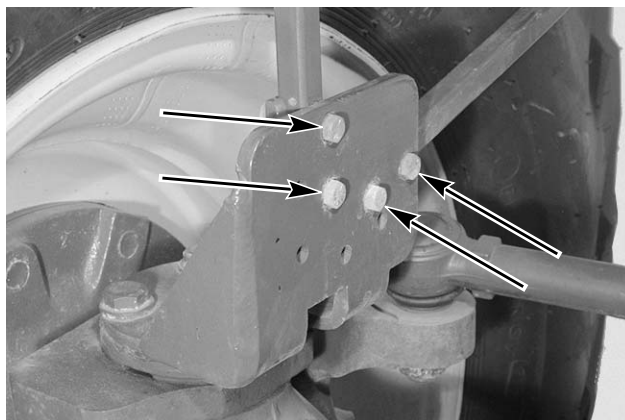

G1741MP

Reinstall both fenders to the fender brackets. Tighten the bolts and nuts.

## BOOM EXTEND CYLINDER TROUBLESHOOTING

**NOTE:** If the extend cylinder will extend but will not retract or retracts slowly, repair or replace the load check valve on the cylinder.

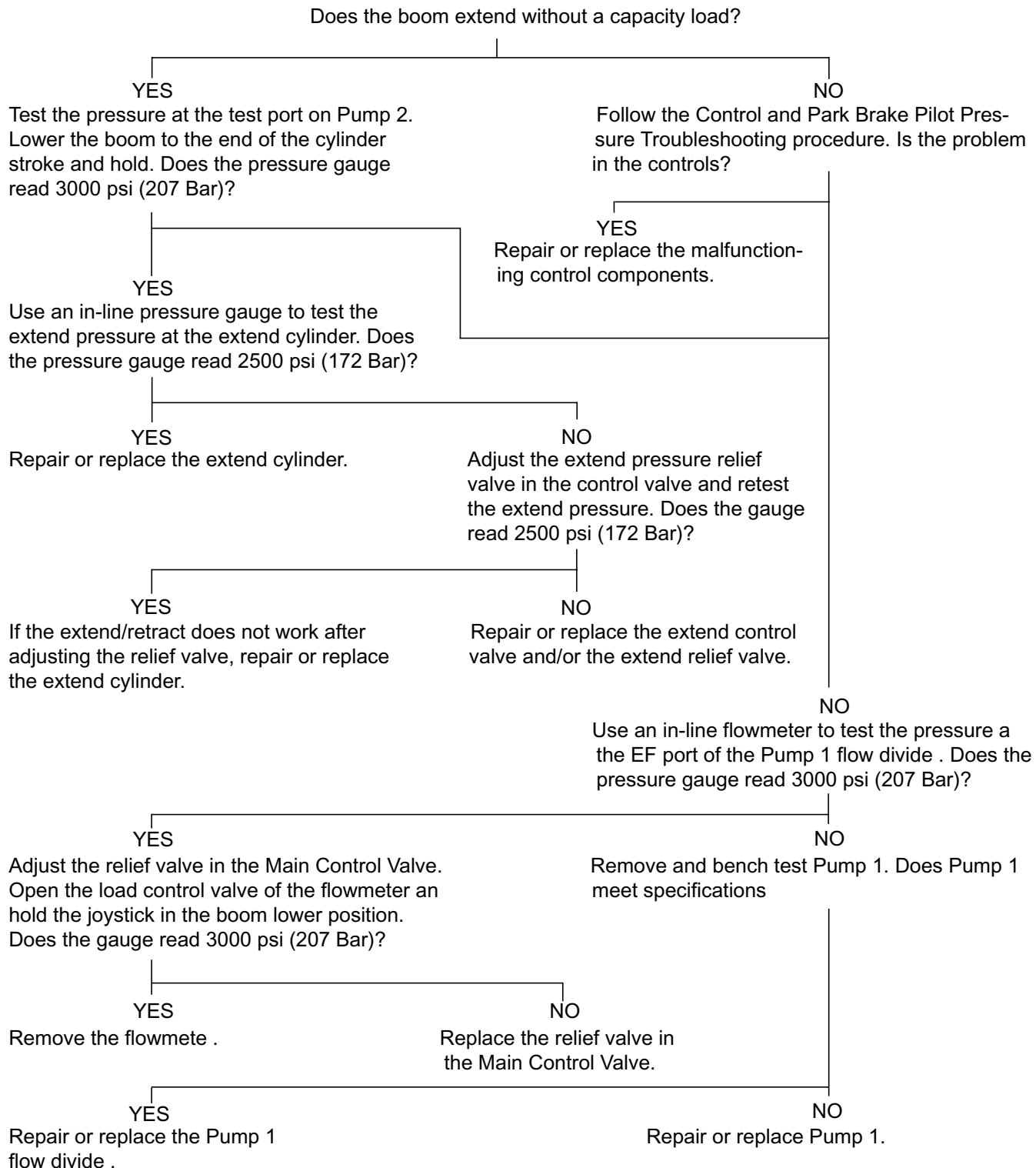

## PUMP 2 PRESSURE TEST

**NOTE:** Before performing any hydraulic test, check for any visible leaks or component damage. Repair or replace the leaking component before proceeding with the test.

### STEP 1

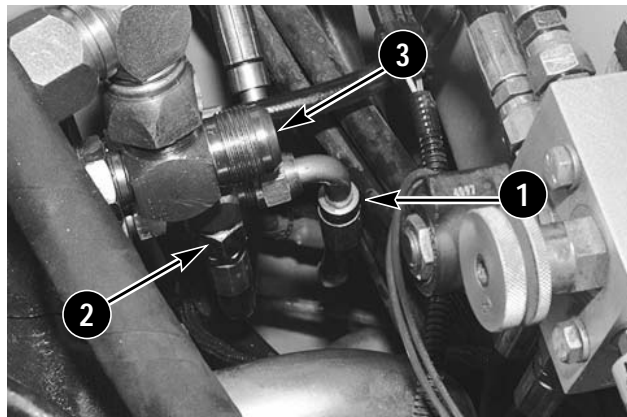

G1236MP

Remove and plug the steering valve supply hose (1) and the frame leveling hose (2) from the tee adapter on port PF of PUMP 2.

**NOTE:** The main control valve supply hose is removed from the Pump 2 EF port tee adapter (3) for access and photo purposes.

### STEP 2

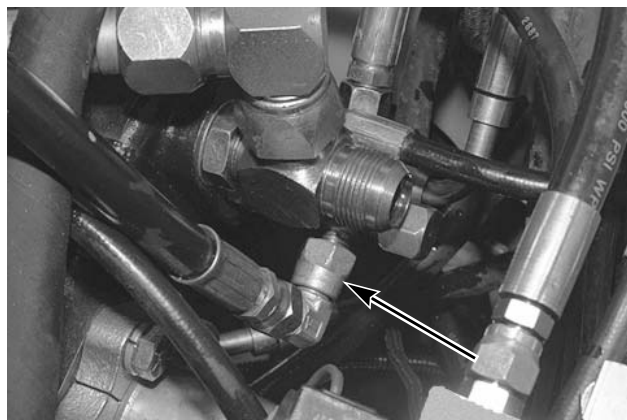

G1237MP

Install a 5000 PSI pressure gauge to one port of the tee adapter.

### STEP 3

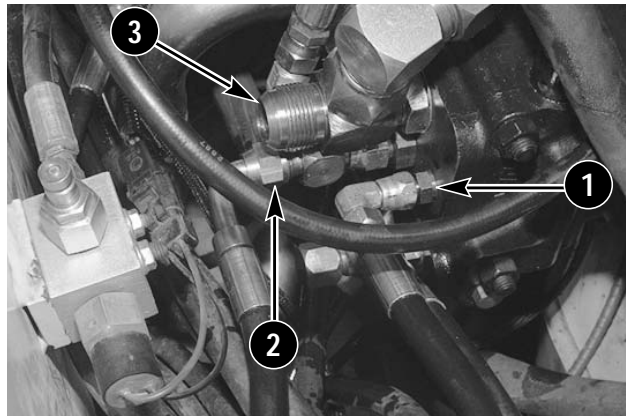

G1238MP

Remove and plug the load sense hose from the LS (1) port of the pump. Install a hose between the open port of the PF port tee adapter (2) and the LS port (1) of the pump.

**NOTE:** The main control valve supply hose is removed from the Pump 2 EF port tee adapter (3) for access and photo purposes.

### STEP 4

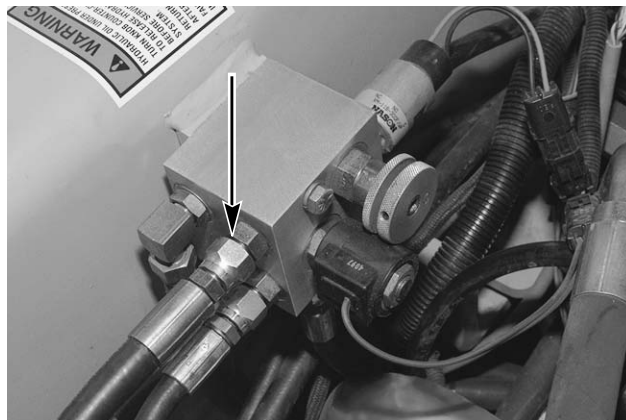

G1199MP

Remove the hose from port AI of the SAHR valve. Install a plug in the hose and cap the port adapter.

### STEP 5

Start the engine and run at 1000 RPM. The pressure gauge should read 2500 PSI (172 Bar). If the pressure is less than 2500 PSI (172 Bar), repair or replace the pump.

## EXTENSION CYLINDER QUICK TEST

### STEP 1

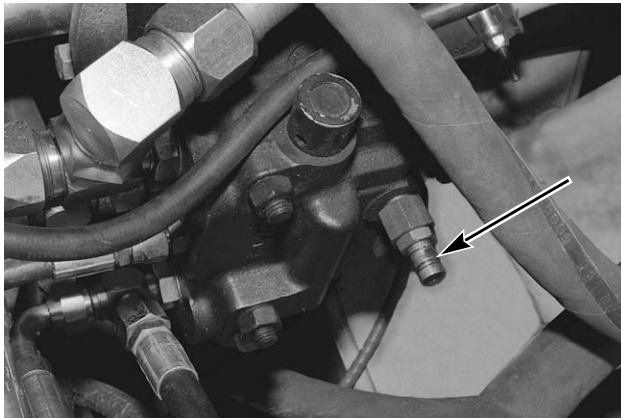

G1198MP

Install a 5000 PSI pressure gauge and hose on the test port of Pump 2.

**NOTE:** *The hose must be long enough to observe the pressure gauge from inside the cab or standing clear of the forklift.*

### STEP 2



G1244MP

Start the engine and run at 1000 RPM. Retract the boom until the boom extension cylinder is at the end of its stroke and hold the joystick in the RETRACT position. The pressure gauge should read 3000 PSI (207 Bar).

If the pressure is more than 3000 PSI (207 Bar) proceed to the Main Control valve Pressure Relief Test and Adjustment section of this manual.

If the pressure is less than 3000 PSI (207 Bar), proceed to the next step.

If the pressure is 3000 PSI (207 Bar), but the extension cylinder is not working properly, check the boom or extension cylinder barrel for damage.

### STEP 3



G1244MP

Lower the boom until the lift cylinders are at the end of their stroke and hold the joystick in the BOOM LOWER position. The pressure gauge should read 3000 PSI (207 Bar).

If the pressure is less than 3000 PSI (207 Bar), proceed to the Main Control Valve Pressure Relief Test and Adjustment section of this manual before proceeding to the next step.

If the pressure is 3000 PSI (207 Bar), proceed to the next step.

## EXTENSION CYLINDER DIRECT TEST

### STEP 4

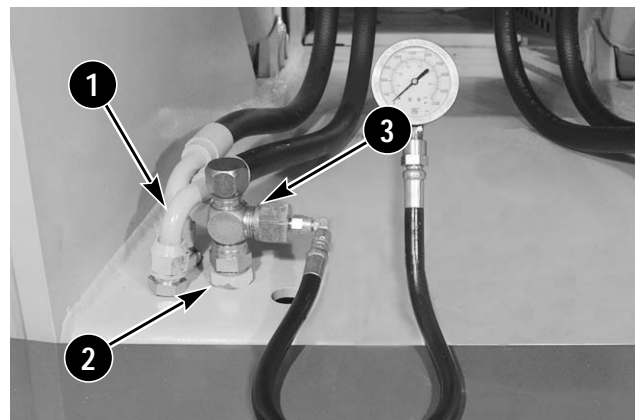

G1219MP

Shut off the engine. Remove the hose (1) from the retract bulkhead fitting (2). Install a 5000 PSI pressure gauge and adaptor (3) on the bulkhead fitting (2) and plug the hose (1) end.

## FRAME LEVELING LOAD CHECK VALVE DIRECT TEST

### STEP 5

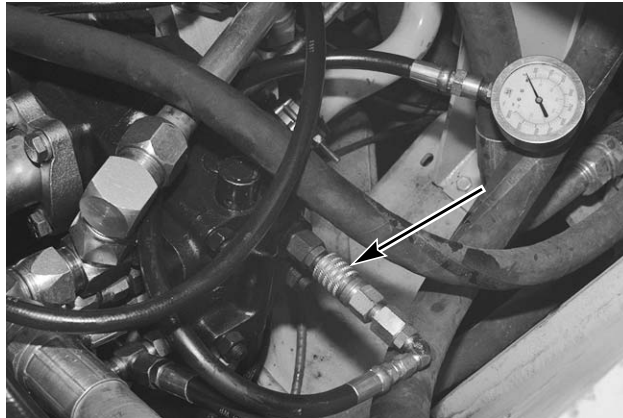

G1224MP

Shut off the engine. Remove the pressure gauge from the test port on Pump 2.

### STEP 6

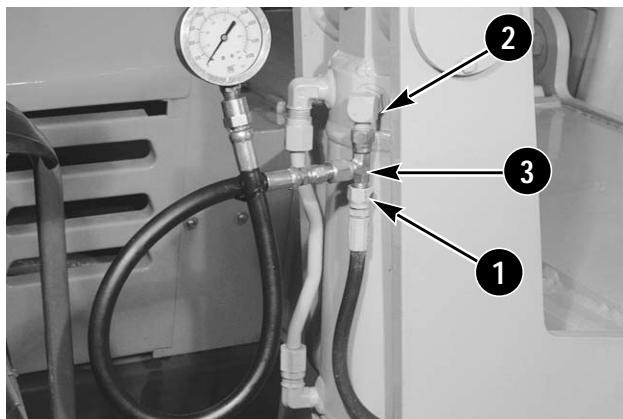

G1207MP

Remove the supply hose (1) from the tilt right (rod) port (2) of the frame leveling cylinder. Install the 5000 PSI (345 Bar) pressure gauge (3) and hose between the cylinder port (2) and supply hose (1).

### STEP 7

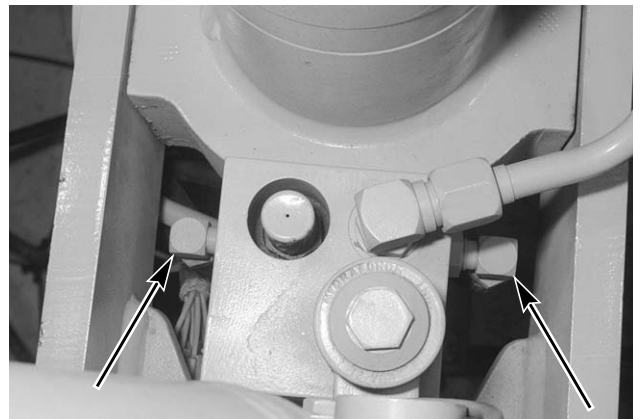

G1241MP

Remove the hoses from the stabilizer cylinder elbow fittings. Cap the fittings and plug the hose ends.

### STEP 8



G1244MP

Start the engine and run at 1000 RPM. Hold the frame leveling switch in the TILT LEFT position (1) until the cylinder reaches the end of its stroke. Move and hold the switch to the TILT RIGHT position (2). The pressure gauge should read 1500 PSI (103 Bar) when the frame is tilting (moving) right.

If the pressure is less than 1500 PSI (103 Bar), proceed to Step 9.

## STEERING CIRCUIT PRESSURE TEST

### STEERING CIRCUIT PRESSURE QUICK TEST

#### STEP 1

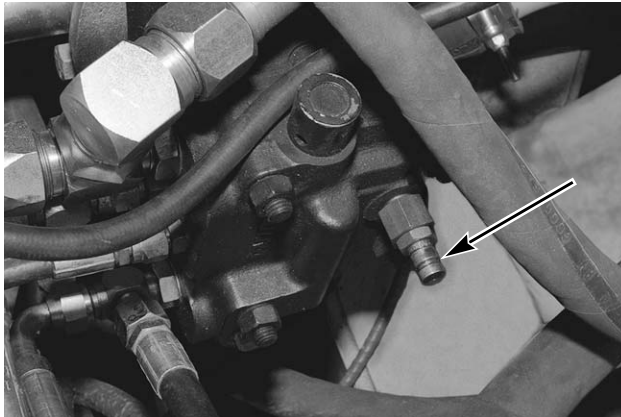

G1198MP

Install a 5000 PSI (345 Bar) pressure gauge and hose on the test port of Pump 2.

**NOTE:** *The hose must be long enough to observe the pressure gauge from inside the cab or standing clear of the forklift.*

#### STEP 2



G1245MP

Start the engine and run at 1000 RPM. Move the Steer Mode Switch (1) to the 4-Wheel Steering position. Turn the steering wheel in one direction until the wheels reach their travel limits and hold. The pressure gauge should read 2500 PSI (172 Bar).

If the pressure is less than 2500 PSI (172 Bar), proceed to the next step.

If the pressure is 2500 PSI (172 Bar), but the steering does not work properly, check the steering linkage and pivot points, and the Steering Mode Valve, before repairing or replacing the steering control unit.

If the pressure is more than 2500 PSI (172 Bar), replace the relief valve in the Pump 2 flow divider.

#### STEP 3



G1244MP

Tilt the frame to the right until the frame leveling cylinder reaches the end of its stroke and hold. The pressure gauge should read 2500 PSI (172 Bar)).

If the pressure is less than 2500 PSI (172 Bar) go to the Pump 2 Pressure Test in this manual.

If the pressure is 2500 PSI (172 Bar), proceed to the next step.

### STEERING CIRCUIT PRESSURE DIRECT TEST

#### STEP 4

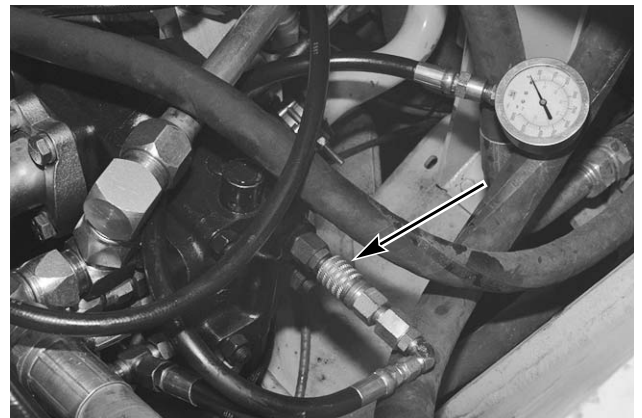

G1224MP

Shut off the engine. Remove the pressure gauge from the Pump 2 test port.

# **Section**

# **603**

## **FRAME LEVELING CYLINDER REMOVAL & INSTALLATION**

**Mustang Telehandler**

## STEP 7



G1530MP

Remove the rod end of the cylinder from the Dynattach first, then raise the chain hoist and remove the base end of the cylinder from the Dynattach.

## TILT CYLINDER INSTALLATION

## STEP 8



G1527MP

Using a chain hoist and lifting strap, put the rod end of the cylinder in the Dynattach first, and position the base end of the cylinder in the mounting bracket using a floor jack to apply upward pressure on the cylinder.

## STEP 9



G1529MP

Align the pivot pin retainer bolt holes, with the holes in the cylinder mount. Reinstall the upper pivot pin using care not to damage the grease fitting while installing the pin.

## STEP 10

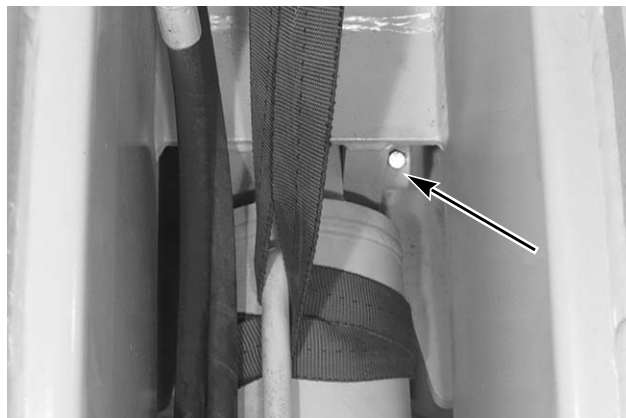

G1528MP

Install the retainer bolt and nut in the pivot pin and tighten.

## STEP 11

Remove the caps and plugs from the valve block fittings and hydraulic hoses.

## STEP 20

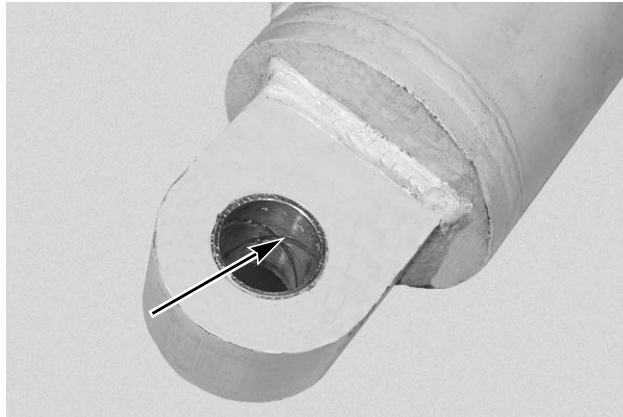

G1549MP

If required, remove and discard the bushing from the base end and the rod end of the cylinder.

## CYLINDER ASSEMBLY

### STEP 21

Clean the cylinder rod threads, rod nut and all cylinder parts in solvent and dry with compressed air. Using compressed air blow out all passages in the valve block.

Inspect all parts for damage or wear. Replace damaged or worn parts.

### STEP 22

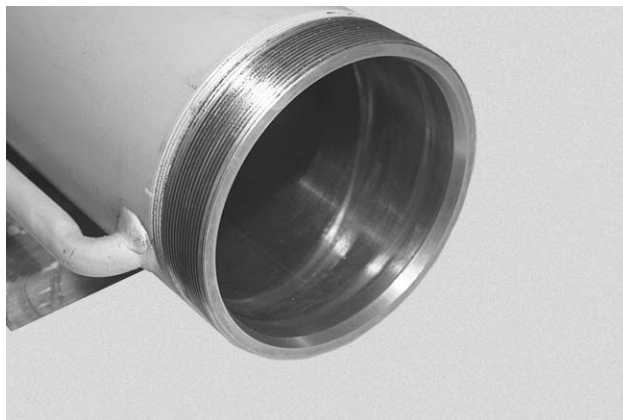

G1550MP

Inspect the cylinder barrel for nicks, scratches or scoring prior to being assembled.

Use crocus cloth to remove minor nicks or scratches.

## STEP 23

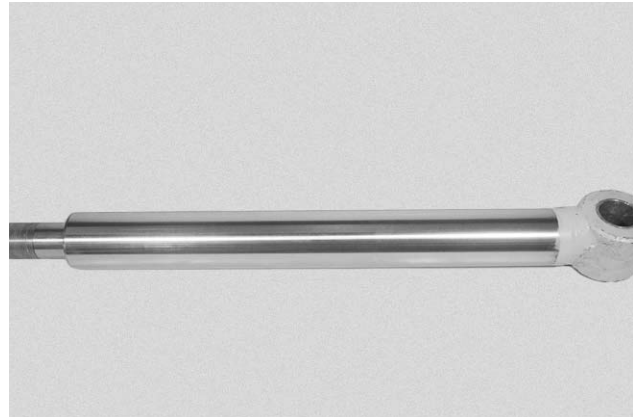

G1551MP

Inspect the cylinder rod for any nicks, scratches or scoring. Roll the rod on a hard flat surface to check for any bending.

## STEP 24

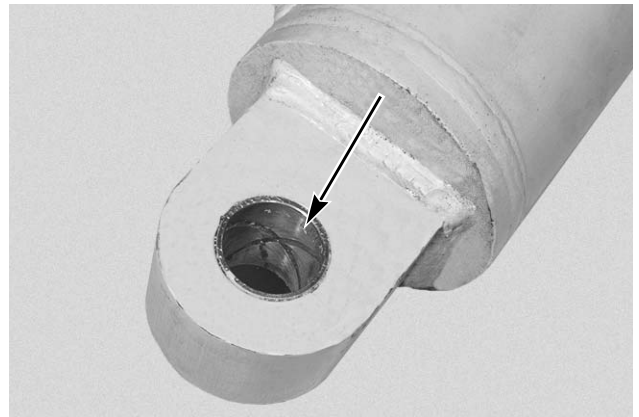

G1549MP

If needed, install a new bushing in the base end and the rod end of the cylinder.

## STEP 25



G1547MP

Install a new inner seal (lip to the inside of the barrel) in the head gland.

**NOTE:** *Lubricate all new seals with clean operating fluid or petroleum jelly before installation.*

# **Section 607**

## **STABILIZER CYLINDER REPAIR**

### **Mustang Telehandler**

## STEP 44

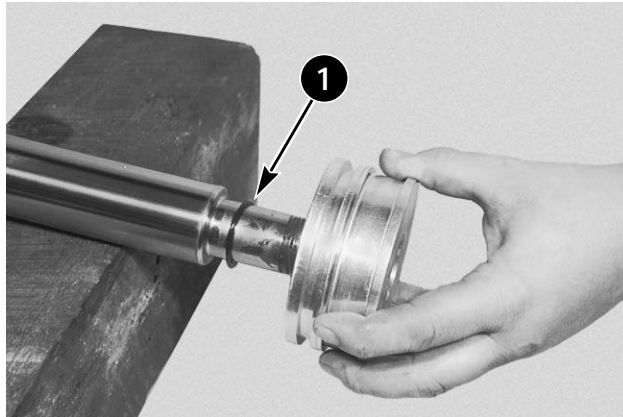

G1576MP

Install a new O-ring (1) and the piston on the rod.

## STEP 45



G1575MP

Install the inner seal on the piston. Be sure the seal is not rolled or twisted.

## STEP 46

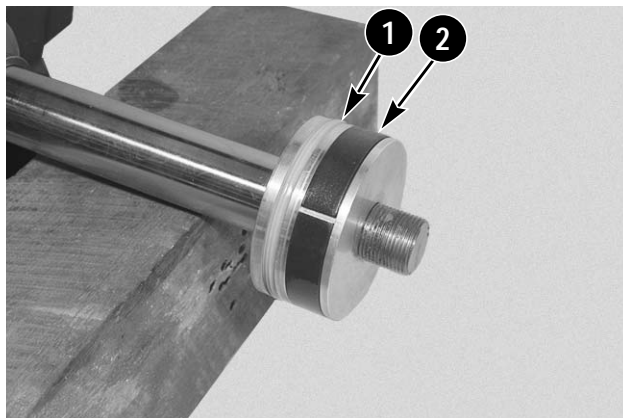

G1574MP

Install a new wear ring (1) and seal (2) on the piston.

## STEP 47

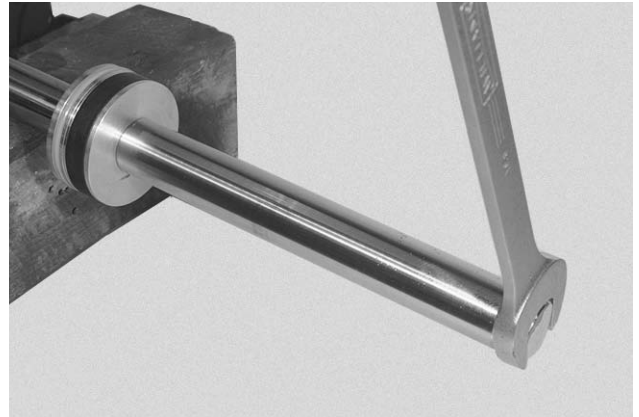

G1573MP

Apply Loctite #271 Thread Lock (or equivalent) on the threads of the base end rod and install the cross tube rod and tighten.

## STEP 48

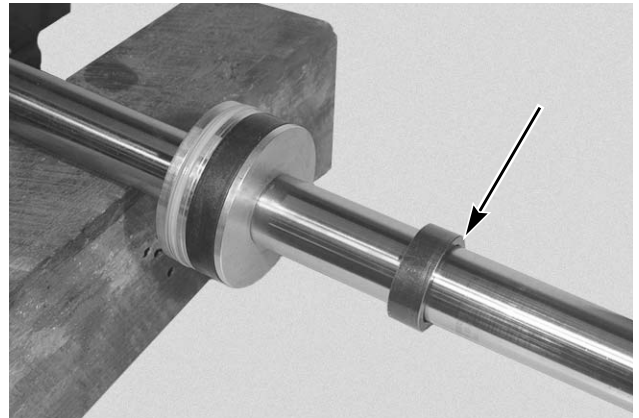

G1572MP

Install the spacer on the rod.

## STEP 49

Remove the rod assembly from the vise.

## STEP 50

Put the cylinder barrel in the vise.

# **Section 609**

## **LIFT CYLINDER REMOVAL AND INSTALLATION**

### **Mustang Telehandler**

CLICK HERE TO **DOWNLOAD** THE COMPLETE MANUAL

- Thank you very much for reading the preview of the manual.
- You can download the complete manual from: [www.heydownloads.com](http://www.heydownloads.com) by clicking the link below



- Please note: If there is no response to CLICKING the link, please download this PDF first and then click on it.

CLICK HERE TO **DOWNLOAD** THE COMPLETE MANUAL

# Mustang Telehandler

# BOOM EXTEND CYLINDER

## STEP 7

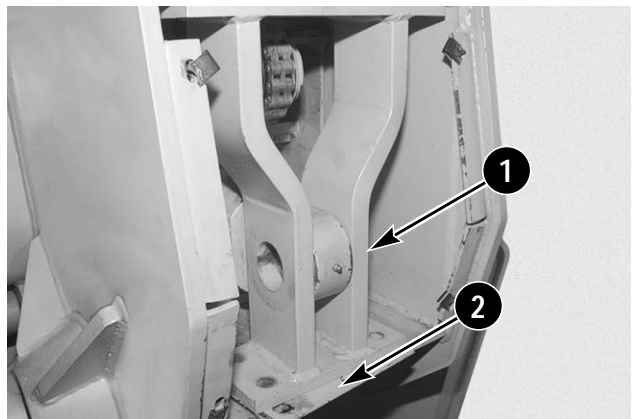

G1663MP

Remove the extend cylinder rod end mounting bracket (1) and shim (2).

## STEP 8

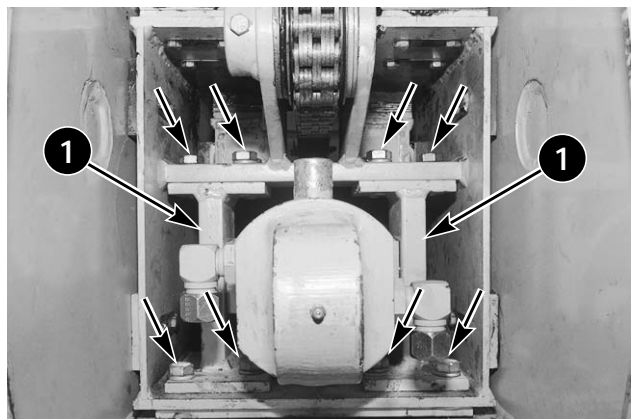

G1662MP

Loosen and remove the ten bolts from the trunnion mounts. Mark the trunnion mounts (1) for correct assembly.

## STEP 9

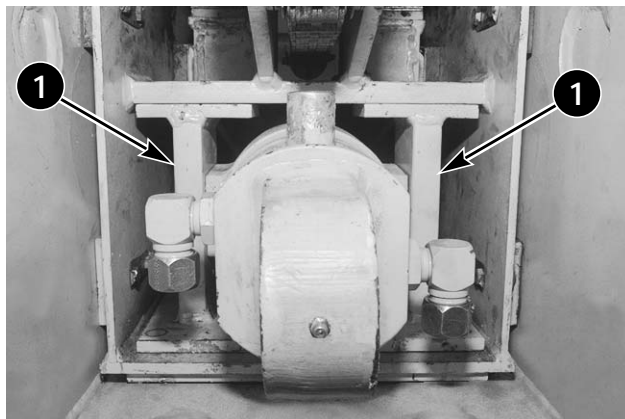

G1661MP

Attach a hoist and lifting strap to the extend cylinder. Pull the extend cylinder and trunnion mounts (1) out the rear of the boom, remove both trunnion mounts from the cylinder.

**NOTE:** As the extend cylinder is removed it will be necessary to reposition the lifting strap on the extend cylinder.

## STEP 10

Remove the extend cylinder from the boom.

## EXTEND CYLINDER INSTALLATION

## STEP 11

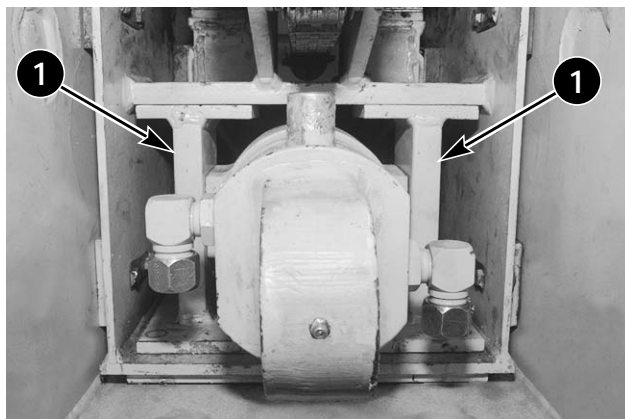

G1661MP

Using a hoist and lifting strap install the extend cylinder halfway into the boom, reposition the lifting strap as needed. Install the trunnion mounts (1) onto the extend cylinder and slide cylinder assembly into position.

# **Section**

# **612**

## **BOOM EXTEND CYLINDER REMOVAL AND INSTALLATION 4-SECTION HIGH BOOM MODELS**

### **Mustang Telehandler**

## GENERAL INFORMATION

Boom removal can be accomplished in several ways, depending on the scope of damage or the reason for removal. If the boom assembly must be removed because of other machine damage, it may be removed as a complete assembly. If the boom is to be removed because of damage to the boom that requires extensive repairs, it may be desirable and easier to remove the inner and intermediate boom sections from the outer section first. Refer to Sections 703 and 706 of this manual to remove the inner and intermediate boom sections.

Boom assembly removal procedures will also be determined by the type and capacity of the lifting device that will be used to support and remove the boom assembly.

Gehl Company recommends using two rolling gantry type hoists each with a minimum capacity of 3000 lb to lift and support each end of the boom assembly. The following boom assembly removal procedures will be done using a rolling gantry hoist connected to each end of the boom.

## BOOM ASSEMBLY REMOVAL

### STEP 1

Park the unit on a solid level surface with adequate room for boom removal. Put wood blocks under the nose portion of the boom and lower the boom so that the nose portion is resting on the wood blocks and remains level.

### MANDATORY SAFETY SHUTDOWN PROCEDURE

**BEFORE cleaning, lubricating or performing service on this equipment:**

1. Bring the machine to a full parking stop on level surface. (If parking on a slope or hillside cannot be avoided, park across the slope and block the tires.)
2. Fully retract the boom and lower the attachment to the ground.
3. Place controls in **NEUTRAL** and set the Park Brake.
4. Idle the engine for gradual cooling.

5. Turn the Starter Key Switch to OFF position and remove key (take key with you for security reasons).

**ONLY when you have taken these precautions can you be sure its safe to proceed. Failure to follow the above procedures could lead to serious personal injury or death.**

### RELIEVING HYDRAULIC PRESSURE

1. Open the rear door to allow access to the control valve.

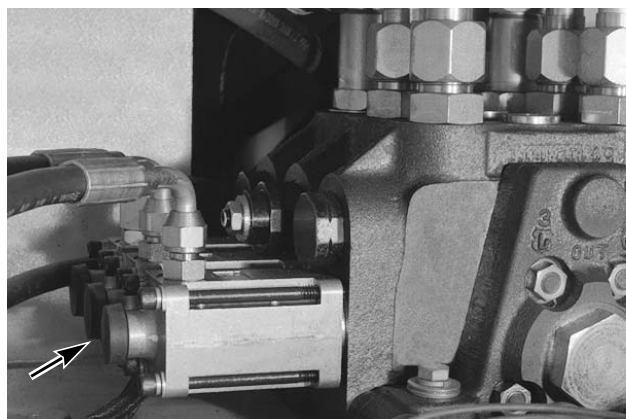

G1204MP

2. Locate the attachment Boom Raise section (first section) on the left hand side of the control valve and remove the rubber boot. Using a screwdriver, turn the screw IN (clockwise) until it bottoms, then turn it OUT (counterclockwise) until it bottoms. Reinstall the rubber boot.

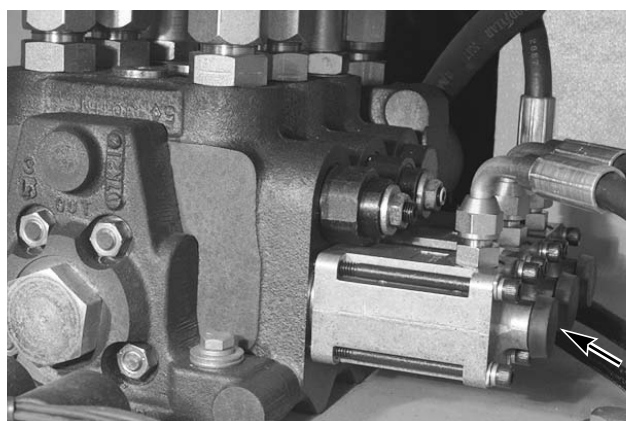

G1203MP

3. Locate the attachment Boom Lower section (first section) on the right hand side of the control valve and remove the rubber boot. Using a screwdriver, turn the screw IN (clockwise) until it bottoms, then turn it OUT (counterclockwise) until it bottoms. Reinstall the rubber boot.

# **Section**

# **703**

**INNER BOOM SECTION REMOVAL AND  
INSTALLATION**

**Mustang Telehandler**

# **Section**

# **704**

## **TELESCOPING BOOM DOUBLE CHAIN AND ROLLER BEARING REPLACEMENT**

### **Mustang Telehandler**

## STEP 1

With the engine running, retract the telescoping boom and level it according to the boom angle indicator, which should read "0".

## **MANDATORY SAFETY SHUTDOWN PROCEDURE**

**BEFORE cleaning, lubricating, or performing service on this equipment:**

1. Bring machine to full parking stop on level surface. (If parking on a slope or hillside cannot be avoided, park across the slope and block the tires.)
2. Fully retract the boom and lower the attachment to the ground.
3. Place controls in NEUTRAL and set Park Brake.
4. Idle engine for gradual cooling.
5. Turn the Starter Key Switch to OFF position and remove key (take key with you for security reasons).

**ONLY when you have taken these precautions can you be sure it is safe to proceed. Failure to follow the above procedure could lead to serious personal injury or death.**

## STEP 2

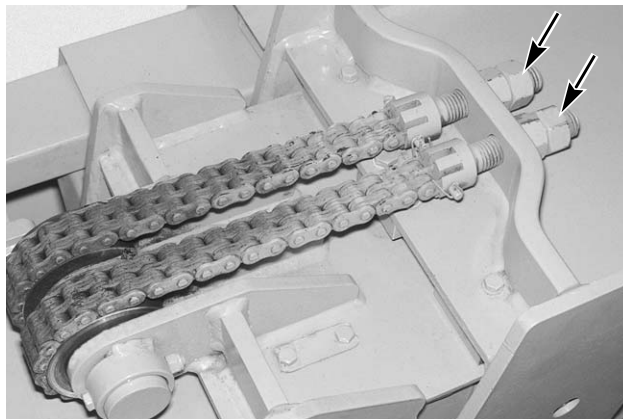

G1635MP

Remove the four nuts that secure the clevis of the double chain assembly to the outer boom. Hang both chains over the front of the inner boom.

## STEP 3

Push the inner boom into the intermediate boom 2 to 3 inches (50 to 76 mm) to relieve tension on the single chain.

## STEP 4

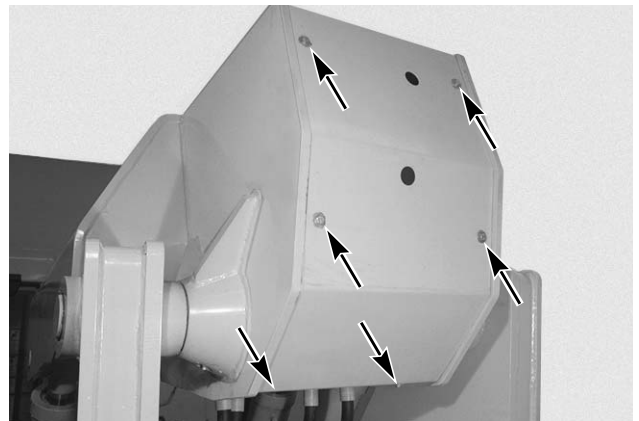

G1614MP

Loosen and remove the six bolts from the rear cover and remove the cover from the boom.

## STEP 5

Relieve the hydraulic pressure and remove the extend cylinder. See Section 610 in this manual for correct procedure.

## STEP 6

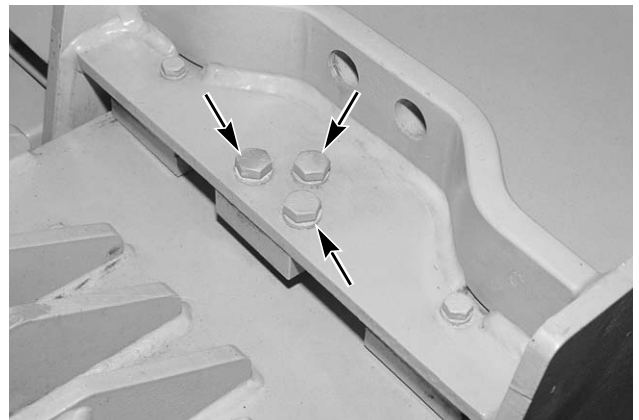

G1638MP

Loosen and remove the three bolts and washers that secure the single chain clevis block to the outer boom.

## STEP 10

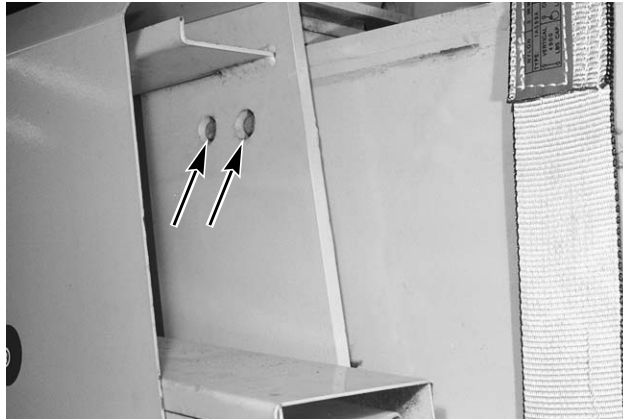

G1627MP

Loosen and remove the two bolts and upper side slide pad and shim from the front of the outer boom.

## STEP 11

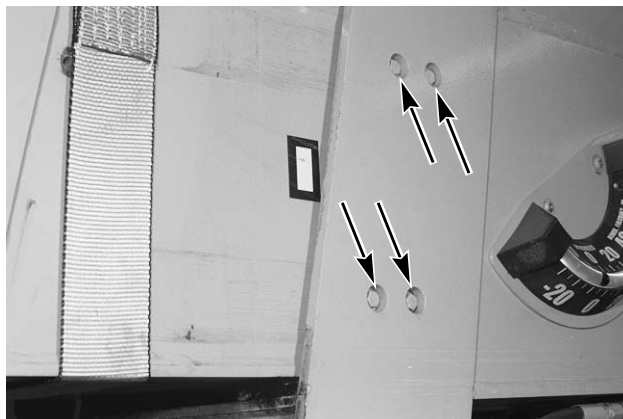

G1625MP

Loosen and remove the four bolts and remove the two side slide pads and shims from the front of the outer boom.

## STEP 12

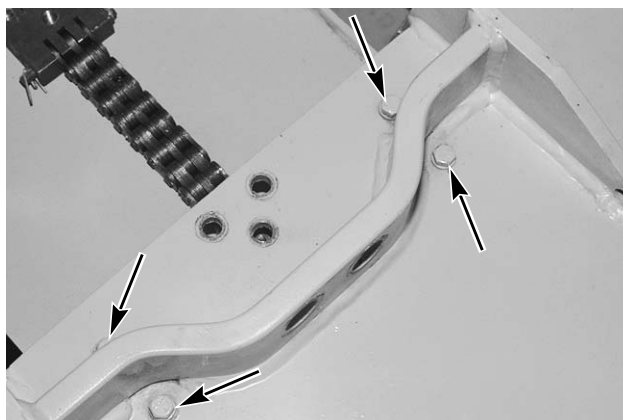

G1628MP

Loosen and remove the bolts and washers from the two top slide pads on the front of the outer boom.

## STEP 13



G1629MP

Remove the two top slide pads and shims from the front of the outer boom.

## STEP 14

Using the hoist and lifting strap, apply upward pressure on the front of the intermediate boom.

## STEP 15

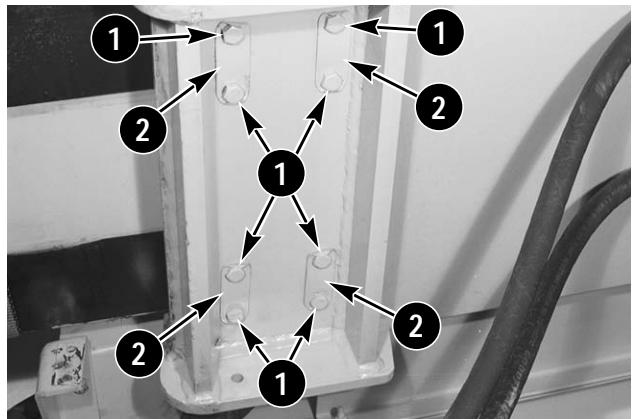

G1630MP

Loosen and remove the bolts (1) and lockplates (2), and remove the two bottom slide pads from the front of the outer boom.

## STEP 16

Using the hoist and lifting strap, pull the intermediate boom out of the outer boom approximately 108 inches. Lower the hoist and measure from the end of the intermediate boom section back 84 inches and make a mark using a dye marker.

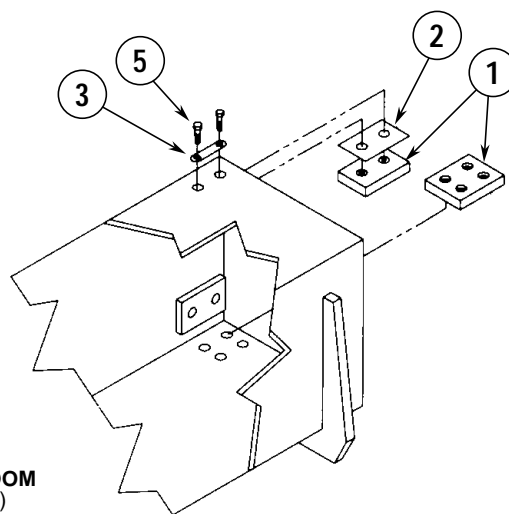
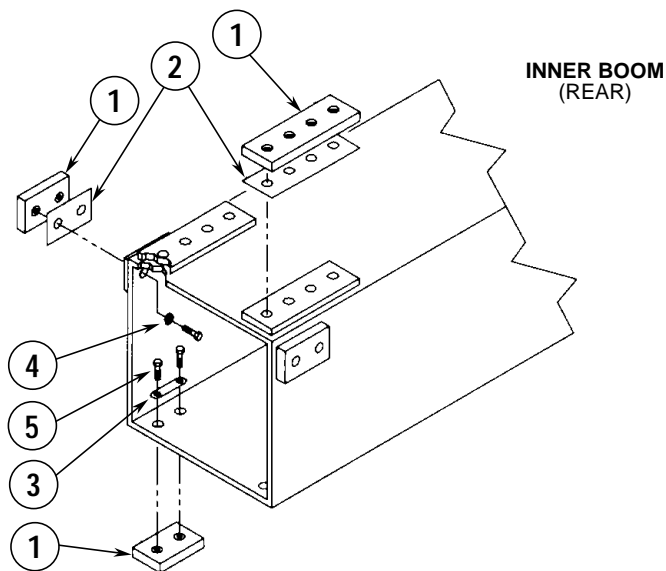

- 1 - SLIDE PAD
- 2 - SHIM
- 3 - LOCK FLAT
- 4 - LOCK WASHER
- 5 - CAP SCREW

G1677MS

## STEP 4

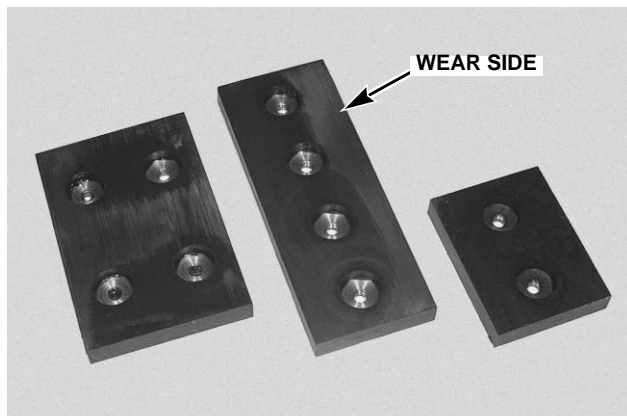

G1613MP

### INSTALLATION OF SLIDE PADS

Install a slide pad onto the boom section with the wear side facing away from the boom section on which it is being mounted. Place any shims or spacers between the slide pad and the boom which it is being mounted on. See Page 709-2 of this section for information.

## STEP 5



G1652MP

Apply Loctite 271 (red) Thread Lock (or equivalent) on the threads of the bolt used to secure the slide pad.



**4-Section Low Boom Model**

## GENERAL INFORMATION

Boom removal can be accomplished in several ways, depending on the scope of damage or the reason for removal. The boom can be removed as a complete assembly, or it may be desirable to remove specific sections of the boom assembly. Please refer to the appropriate sections of this manual for information on removing individual boom sections, replacing boom chains, replacing slide pads and replacing boom hydraulic hoses and tubes.

This section will identify the procedures necessary to remove the complete boom assembly. Boom assembly removal procedures are determined by the type and capacity of the lifting device that will be used to support and remove the boom assembly.

Mustang Manufacturing Company recommends using two rolling gantry type hoists each with a minimum capacity of 3000 lbs. (1360 kg) to lift and support each end of the boom assembly.

## BOOM ASSEMBLY REMOVAL

### STEP 1

Remove any fork carriage or other attachments from the machine.

### STEP 2

Park the machine on a solid level surface with adequate room for boom removal. Fully retract the boom. Put wooden blocks under the front nose portion of the boom and lower the boom so that the nose portion of the boom is resting on the wooden blocks and remains level. Shut off the machine, follow the Mandatory Safety Shutdown Procedure.

## MANDATORY SAFETY SHUTDOWN PROCEDURE

**BEFORE** cleaning, lubricating, or performing service on this equipment:

1. Bring the machine to a full stop on level surface. (If parking on a slope or hillside cannot be avoided, park across the slope and block the tires.)
2. Fully retract the boom and lower the attachment to the ground.
3. Place controls in NEUTRAL and set park brake.
4. Idle engine for gradual cooling.
5. Turn the starter key switch to OFF position and remove the key (take key with you for security reasons).

**ONLY** when you have taken these precautions can you be sure it is safe to proceed. Failure to follow the above procedure could lead to serious personal injury or death.

### STEP 3

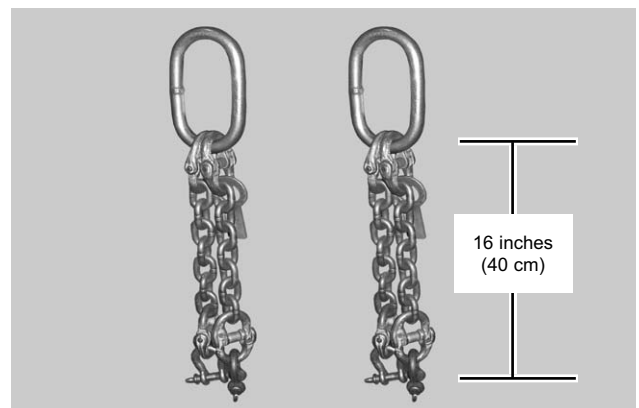

Use two lifting chain assemblies with a certified lifting capacity of 4000 lbs. (1800 kg) to lift and support the boom assembly. The lifting chain assemblies should have two chains with an equal length of 16 inches (40 cm).

## STEP 8

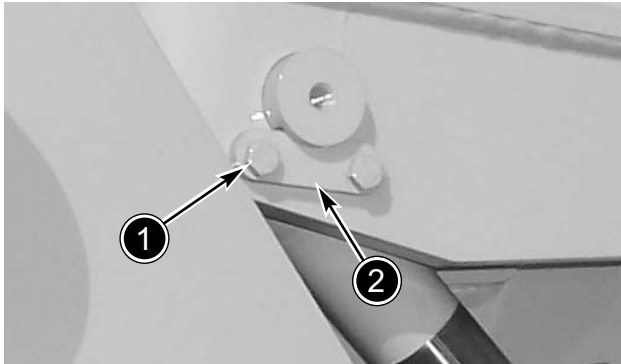

Remove the two retaining clip bolts (1) and the retaining clip (2) from the upper slave cylinder pin (both sides).

## STEP 9

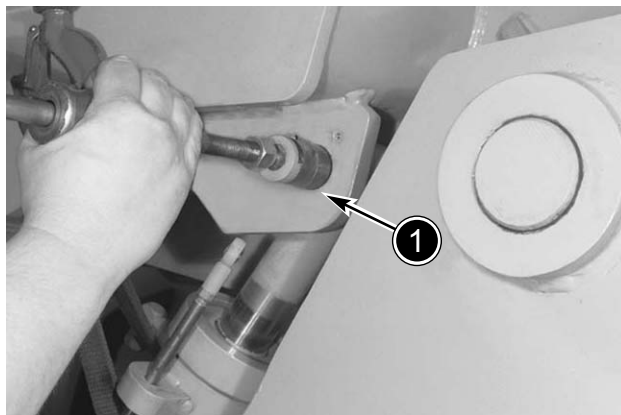

Using a slide hammer, remove the upper slave cylinder pins (both sides).

**NOTE:** Depending on the extent of damage to the machine (if any), the years of service or the infrequency of maintenance (lack of greasing), removal of the boom pivot pin may be very challenging. Use a large brass drift and heavy sledge hammer or a hydraulic ram pusher arrangement to drive the shaft out of the boom assembly and chassis uprights.

## STEP 10

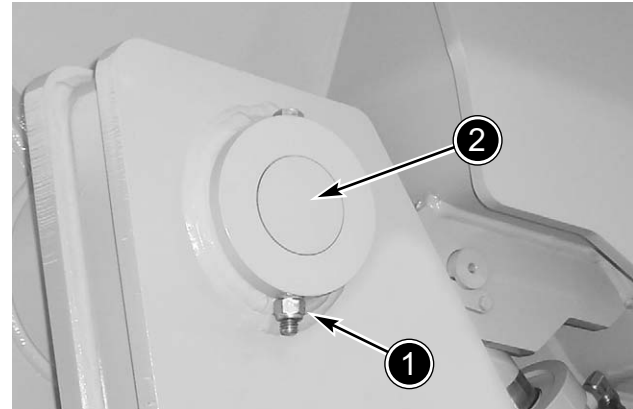

Remove the lock nut (1) and pivot pin retaining bolt. Remove the boom pivot pin (2) from the boom assembly.

## STEP 11



Place a small block (1) between the lift cylinder and the chassis (both sides). Place a block (2) between the slave cylinder and the boom upright (both sides).

## STEP 12

Lift the rear of the boom assembly high enough to clear the chassis boom uprights. If necessary, lift and adjust the front of the boom so that the boom is level.

**NOTE:** The machine may be started and carefully backed away from under the boom, or the rolling gantry hoists may be used to roll the boom assembly away from the machine.

# Mustang Telehandler LOW BOOM - 1ST INTERMEDIATE

## STEP 21

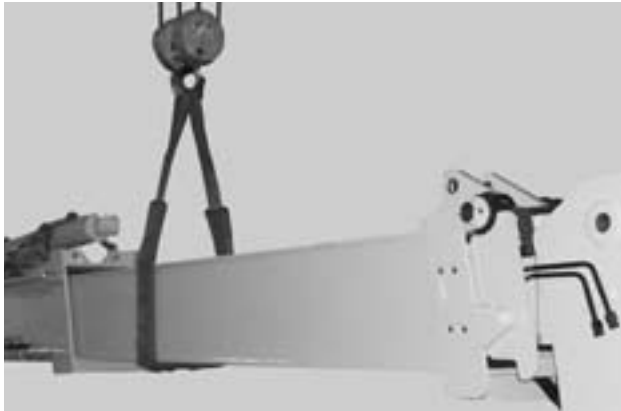

Install the 1st intermediate boom assembly into the outer boom using a hoist and lifting strap. Reposition the hoist and lifting strap to maintain a balanced lifting point as the boom assembly is inserted.

## STEP 22

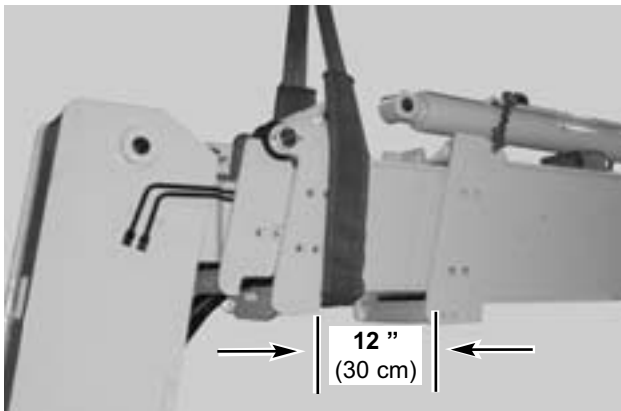

Leave approximately 12 inches (30 cm) of the 1st intermediate boom assembly extending out of the outer boom. Using the hoist and lifting strap, apply upward pressure to the intermediate boom assembly.

## STEP 23



Apply grease to the top of the two bottom outer boom front slide pads.

## STEP 24

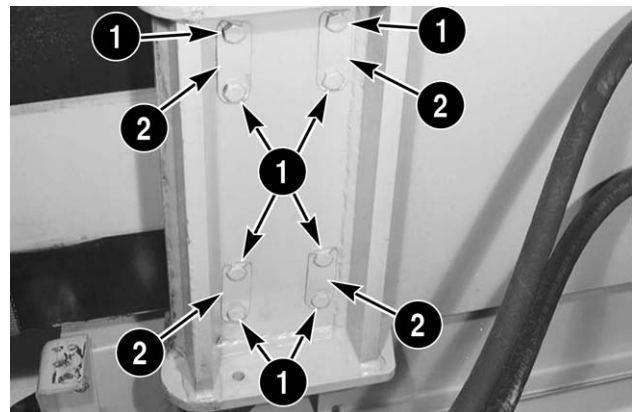
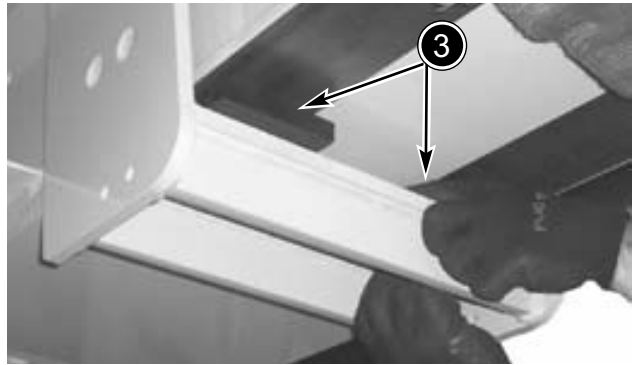

Reinstall the bottom slide pads (3) to the front of the outer boom using the lock plates (1) and bolts (2). Use Loctite® 271 (red) Thread Lock (or equivalent) on the threads of the bolts and tighten to 30 ft.-lbs. (40 Nm) torque. Bend each end of the lock plates up.

## STEP 25

Lower the hoist and lifting strap to relieve the upward pressure on the boom assembly; leave hoist and lifting strap attached to the boom assembly.

## STEP 26



Reinstall the boom side slide pads to the front of the outer boom using eight bolts and lock washers (1) (four on each side). Use Loctite® 271 (red) Thread Lock (or equivalent) on the threads of the bolts and tighten to 30 ft.-lbs. (40 Nm) torque.

# Mustang Telehandler HIGH BOOM - 1ST INTERMEDIATE

## STEP 22

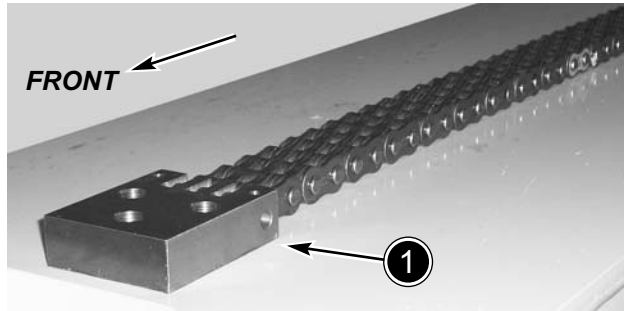

Be sure the top single boom chain remains on top of the 1st intermediate boom with the clevis block (1) at the front of the boom.

## STEP 23

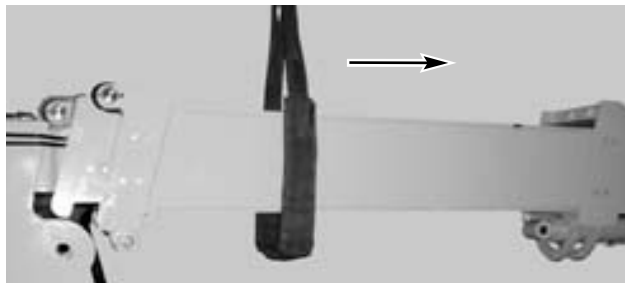

Position the hoist and lifting strap around the 1st intermediate boom assembly to maintain a balanced lifting point, and install the 1st intermediate boom assembly in the outer boom.

## STEP 24

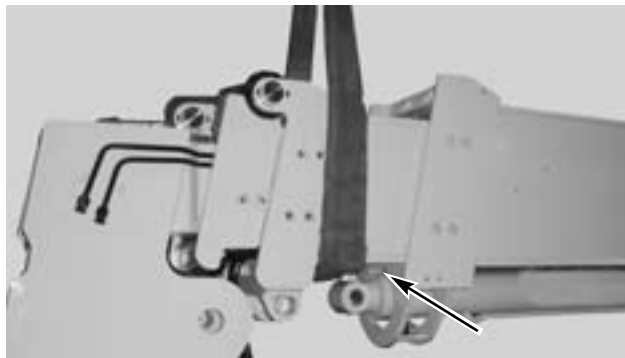

Leave approximately 12 inches (30 cm) of the 1st intermediate boom assembly extending out of the outer boom. Using the hoist and lifting strap, maintain upward pressure on the 1st intermediate boom section

## STEP 25



Apply grease to the top (wear side) of both front bottom slide pads for the outer boom.

## STEP 26

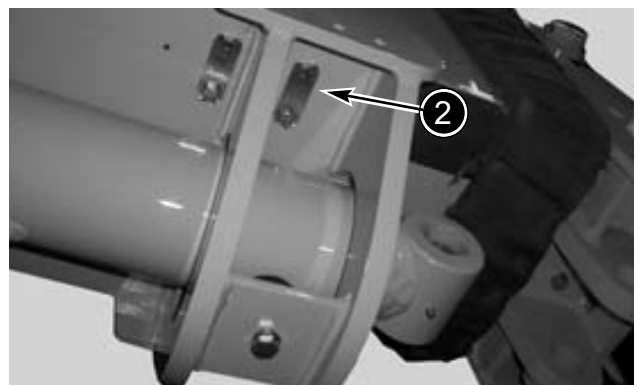
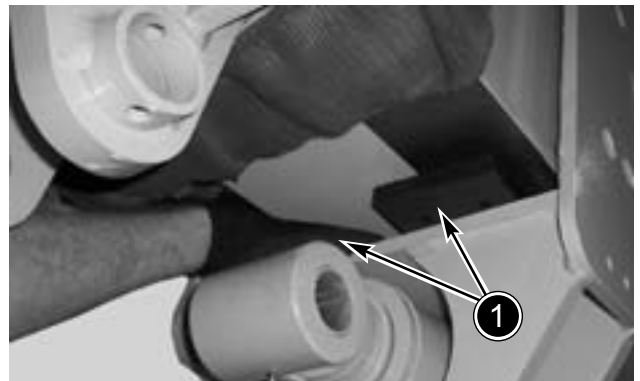

Reinstall the bottom-front slide pads and shims (1) to the bottom-front of the outer boom (both sides) using the eight bolts and four lock plates (2) (four bolts and two lock plates per side). Use Loctite® 271 (red) Thread Lock (or equivalent) on the threads of the bolts and tighten to 30 ft.-lbs. (40 Nm) torque. Bend each end of the lock plates up.

# Mustang Telehandler LOW BOOM - 2ND INTERMEDIATE

## STEP 20

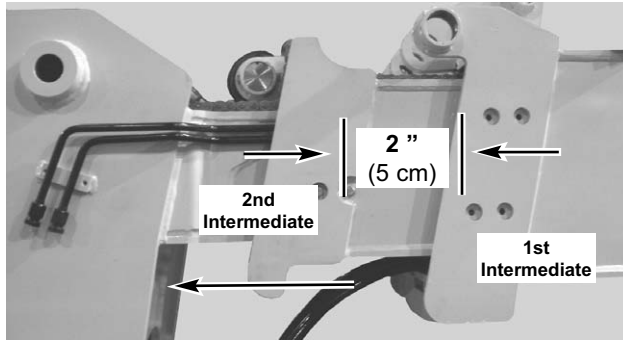

Using a hoist and lifting strap, pull the 2nd intermediate boom out of the 1st intermediate boom approximately 2 inches (5 cm).

## STEP 21

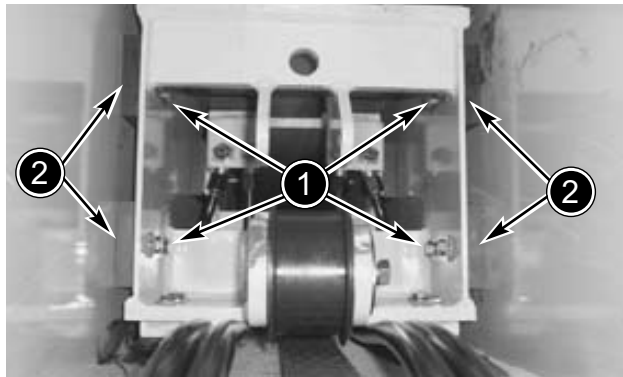

Loosen and remove all eight bolts and four lock plates (1) from the four rear 2nd intermediate boom side slide pads and shims. Remove the four side slide pads and shims (2) from the rear of the 2nd intermediate boom.

## STEP 22

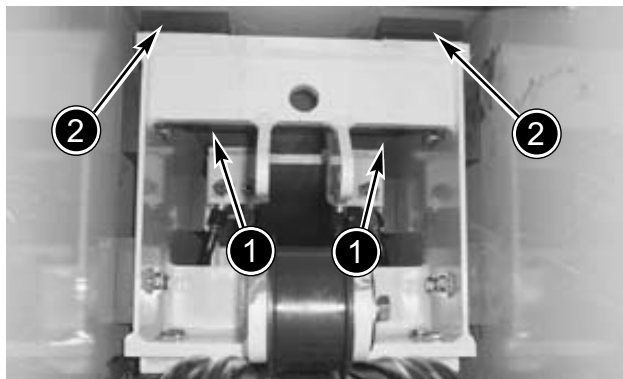

Loosen and remove all eight bolts and four lock plates (1) from the two top rear 2nd intermediate boom slide pads and shims. Remove the two top rear slide pads and shims (2) from the rear of the 2nd intermediate boom.

## STEP 23



Remove the 1st intermediate boom side pads and shims (both sides).

## STEP 24

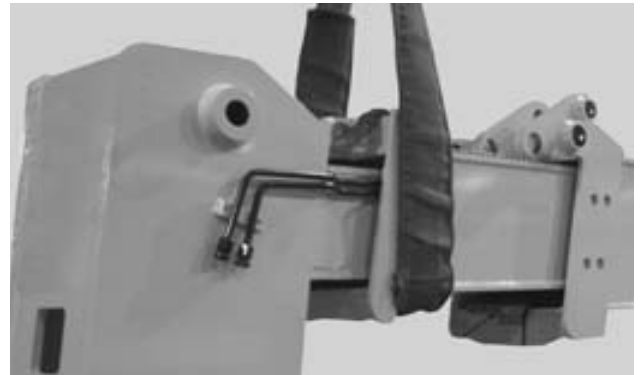

Using the hoist and lifting strap, apply upward pressure on the boom assembly.

## STEP 25

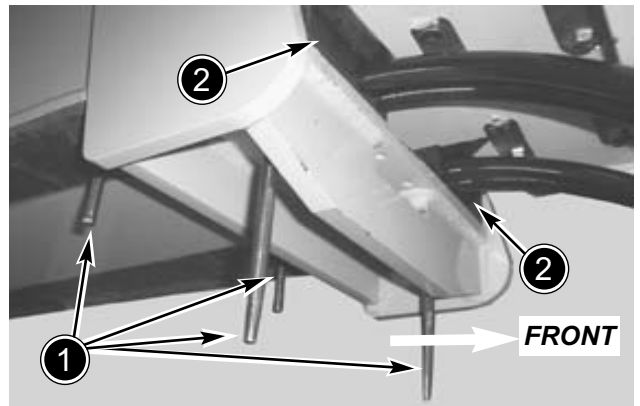

Remove the four 3/8" guide studs (1) from the bottom slide pads on the front of the 1st intermediate boom. Remove the bottom slide pads (2) from the front of the 1st intermediate boom.

# Mustang Telehandler HIGH BOOM - 2ND INTERMEDIATE

## MANDATORY SAFETY SHUTDOWN PROCEDURE

**BEFORE** cleaning, lubricating, or performing service on this equipment:

1. Bring the machine to a full stop on level surface. (If parking on a slope or hillside cannot be avoided, park across the slope and block the tires.)
2. Fully retract the boom and lower the attachment to the ground.
3. Place controls in NEUTRAL and set park brake.
4. Idle engine for gradual cooling.
5. Turn the starter key switch to OFF position and remove the key (take key with you for security reasons).

**ONLY** when you have taken these precautions can you be sure it is safe to proceed. Failure to follow the above procedure could lead to serious personal injury or death.

## GENERAL INFORMATION

If slide pad replacement is required, see Sections 717 and 718 of this manual for the correct procedure.

If chain or roller replacement is required, see Section 719 of this manual for the correct procedure.

## 2ND INTERMEDIATE BOOM REMOVAL

### STEP 1



With the engine running, lower the boom and level it according to the boom angle indicator, which should then read 0°.

### STEP 2

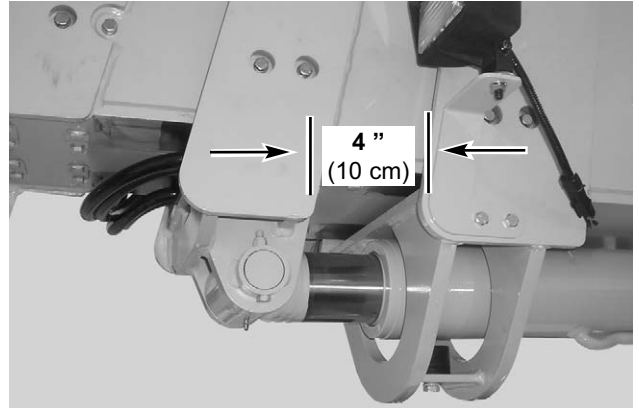

Extend the boom 4 inches (10 cm).

### STEP 3

Shut off the engine following the Mandatory Safety Shutdown Procedure.

### STEP 4

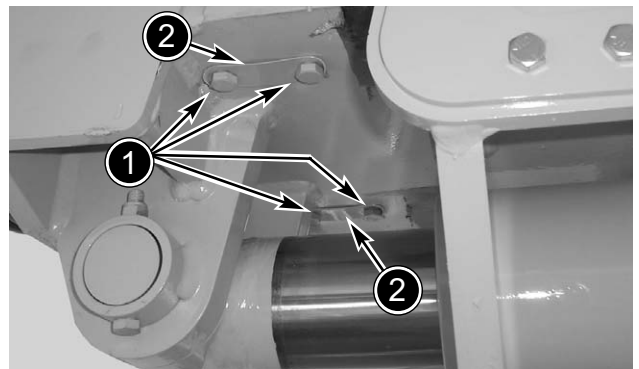

Remove four bolts (1) and two lock plates (2) from the bottom slide pads on the front of the 1st intermediate boom.

### STEP 5

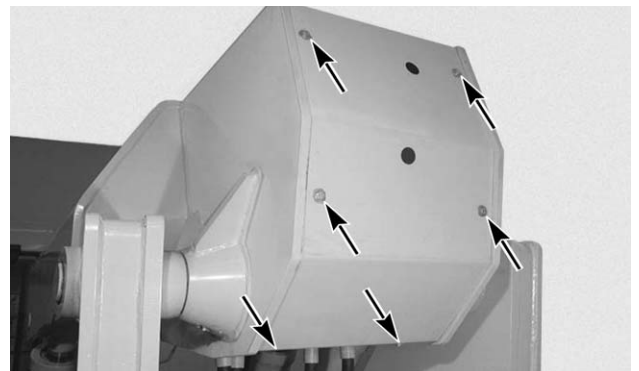

Loosen and remove the six bolts from the rear cover. Remove the cover from the boom.

# Mustang Telehandler HIGH BOOM - 2ND INTERMEDIATE

## STEP 50

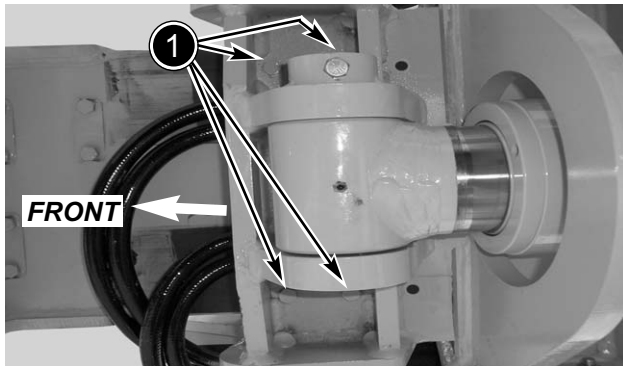

While an assistant pulls the boom hoses out of the front of the 1st intermediate boom, remove the four 3/8" stud guides and install four bolts (1) and two lock plates to the bottom front slide pads on the 1st intermediate boom. Use Loctite® 271 (red) Thread Lock (or equivalent) on the threads of the bolts and tighten to 30 ft.-lbs. (40 Nm) torque.

## STEP 51

Start the engine, fully retract the 1st intermediate boom section into the outer boom and shut off the engine.

## STEP 52

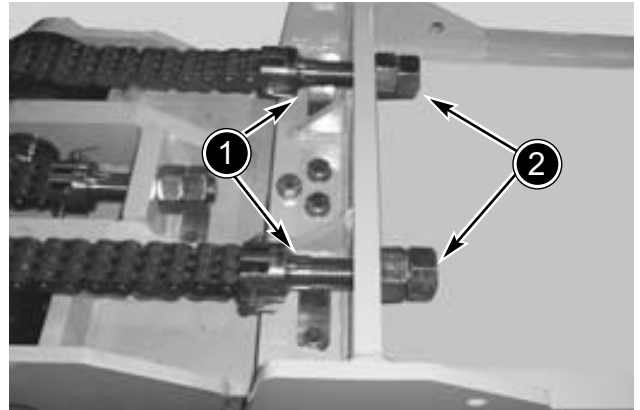

Reinstall the boom chains (1) to the top-front of the outer boom (both sides). Tighten the chain adjuster nuts (2) so that approximately two to three threads of the chain adjuster extend past the outer nut.

## STEP 53

Start the engine and carefully extend the 1st intermediate boom section out about 6 inches (15 cm); refer to the illustration in Step 55 (below).

## STEP 54

Shut off the engine following the Mandatory Safety Shutdown Procedure.

## STEP 55

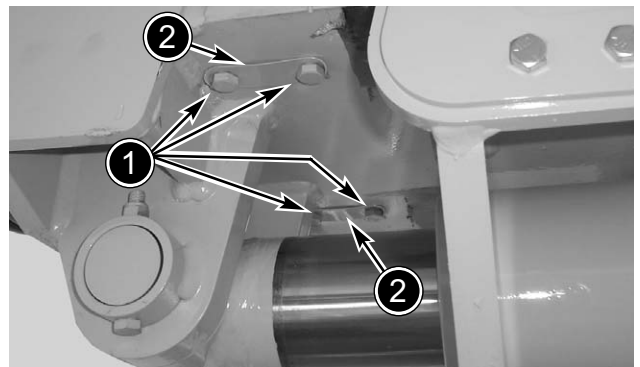

Reinstall the four bolts (1) and two lock plates (2) to the bottom slide pads and shims on the bottom of the 1st intermediate boom section. Use Loctite® 271 (red) Thread Lock (or equivalent) on the threads of the bolts and tighten to 30 ft.-lbs. (40 Nm) torque. Bend each end of the lock plates up.

# **Section**

# **716**

## **BOOM HYDRAULIC HOSE AND TUBE REPLACEMENT 4-SECTION LOW AND HIGH BOOM MODELS**

### **Mustang Telehandler**

## STEP 19

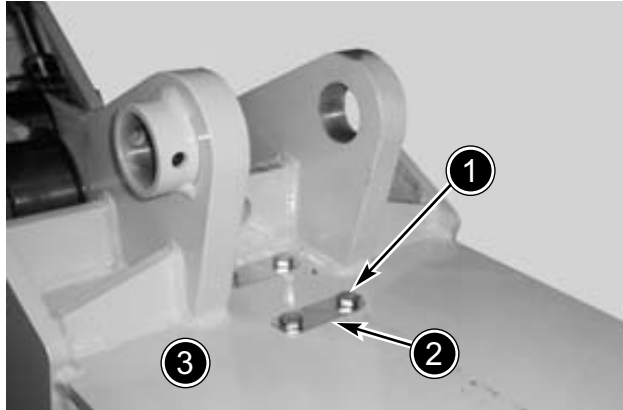

Remove the four top slide pad bolts (1) and the two lock plates (2) from the 1st intermediate boom (3).

**IMPORTANT:** If the slide pads are to be reused, they must be marked as to location and direction (front/rear/top/bottom) as they are removed. Wire tie the shims with each pad. Slide pads and shims must be reinstalled in the exact original position. Refer to Sections 717 and 718 of this manual for the correct procedure to install new replacement slide pads.

## STEP 20

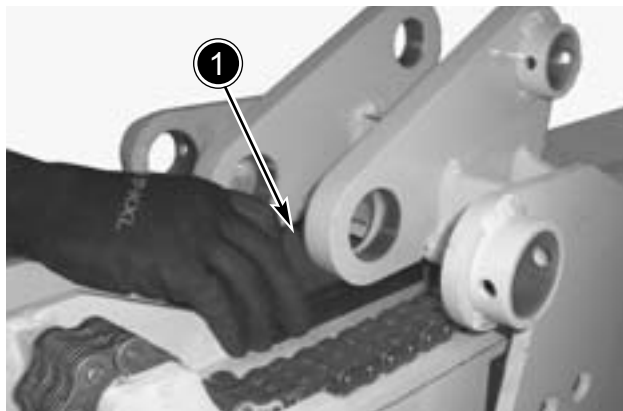

Remove the top-front slide pad (1) from the 1st intermediate boom. (Chain rollers removed for illustrative purposes, it is not necessary to remove the chain rollers.)

## STEP 21

Use a hoist and lifting strap around the front nose of the boom, carefully slide all the boom sections into the outer boom. Skip to Step 26 (Page 716-10).

## STEP 22

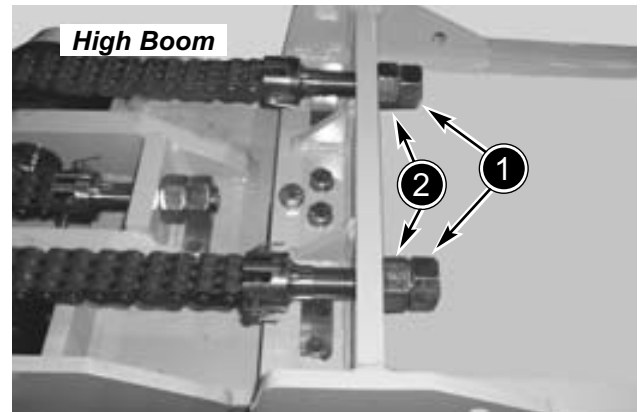

Remove the outer nuts (1) and the inner nuts (2) from the two chain adjusters on the top-front of the outer boom. Remove the chain adjusters from the outer boom and hang the chains over the front of the boom.

## STEP 23

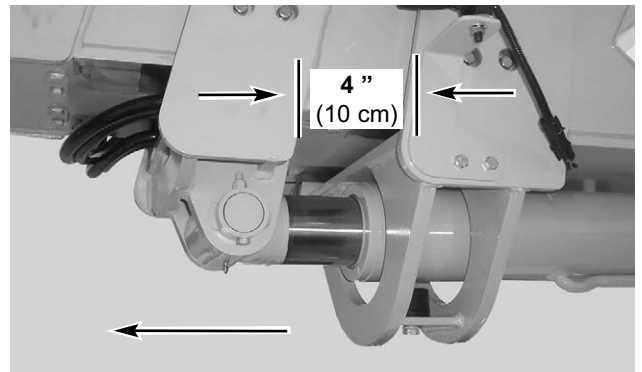

Start the engine and carefully extend the 1st intermediate boom section out of the outer boom 4 inches (10 cm). Shut off engine following the Mandatory Safety Shutdown Procedure.

## STEP 24

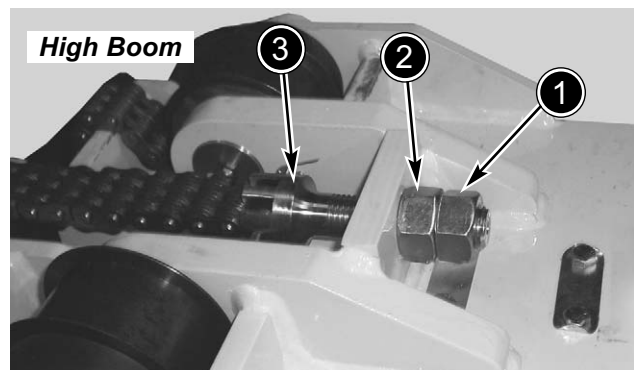

Remove the outer nut (1) and inner nut (2) from the chain adjuster (3). Remove the chain adjuster clevis and chain from the top-front of the 1st intermediate boom and hang it over the front of the boom.

# Mustang Telehandler HOSE AND TUBE REPLACEMENT

## INNER BOOM HYDRAULIC TUBES INSTALLATION

### STEP 5

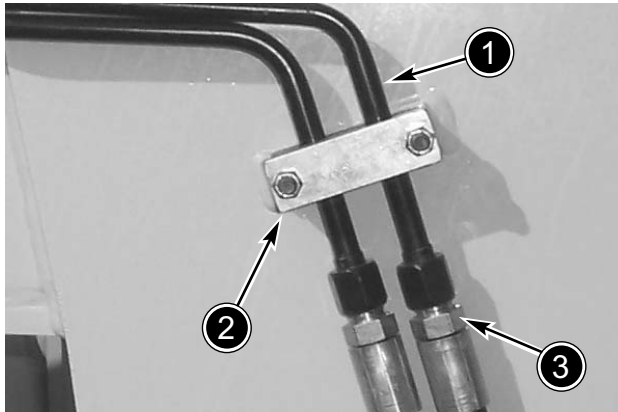

Reinstall the hydraulic tube clamps (1) and hydraulic tubes (2) on both sides of the front inner boom, but do not tighten the clamps. Connect the front hoses (3) and hydraulic tubes (not shown; located on other side), do not tighten the hose and tube connections.

### STEP 6

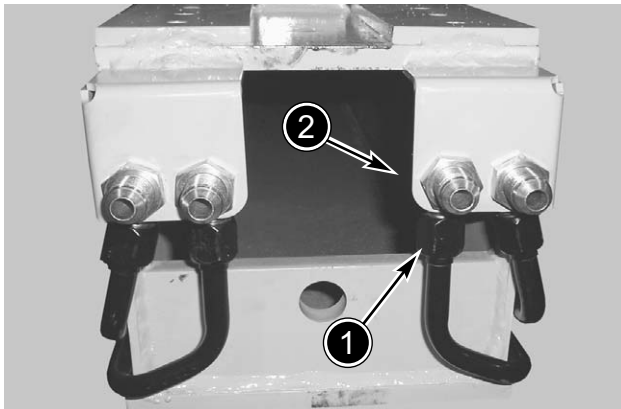

Connect the four hydraulic tubes (1) to the four bulkhead adapters (2) on the rear of the inner boom; leave the connections loose.

### STEP 7

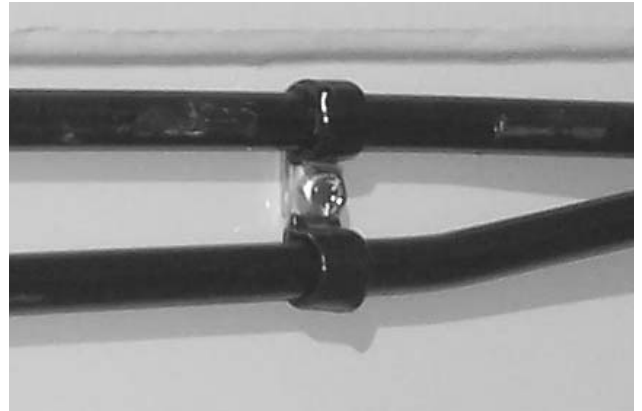

Reinstall all the vinyl clamps to the rear, side and front of the inner boom (both sides). Use Loctite® 271 (red) Thread Lock (or equivalent) on the threads; do not over tighten.

### STEP 8

Tighten the hydraulic tube connections to the hoses and tubes on the front of the inner boom (Step 5).

### STEP 9

Tighten the hydraulic tube connections to the bulkhead adapters on the rear of the inner boom (Step 6).

### STEP 10

Reinstall the inner boom following the procedures in Section 715 of this manual.

# **Section**

# **718**

## **BOOM PAD REPLACEMENT 4-SECTION HIGH AND LOW BOOM MODELS**

### **Mustang Telehandler**

# Mustang Telehandler

# BOOM PAD REPLACEMENT

## STEP 35

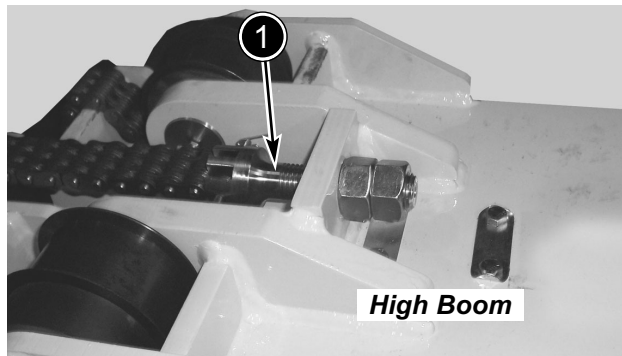
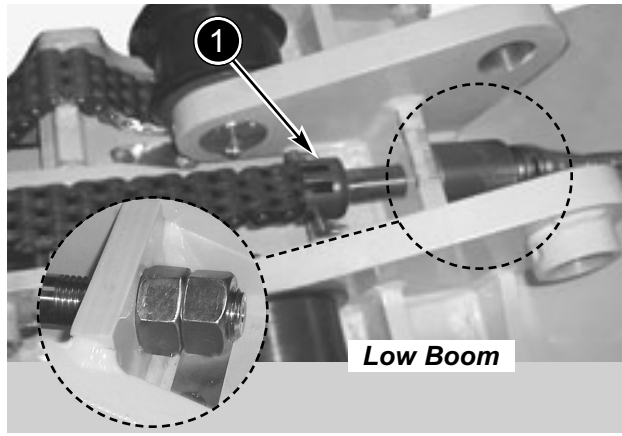

Reinstall the single chain adjuster clevis (1) into the center mount hole of the 1st intermediate boom. Tighten the two chain adjustment nuts so that two to three threads extend past the end of the outer nut (as shown).

## STEP 36

*Low boom* models, continue with Step 37.  
*High boom* models, skip to Step 39.

## STEP 37

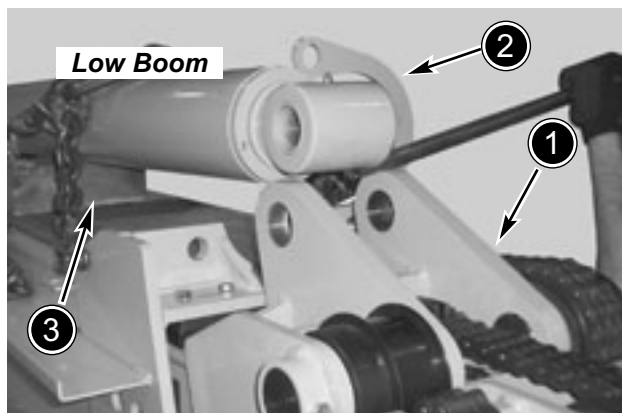

Use a hoist and lifting strap, slide all boom sections into the outer boom. Reinstall the right side chain (1) through the extend cylinder bracket (2). Remove the block (3) and lower the extend cylinder into the extend cylinder mount.

## STEP 38

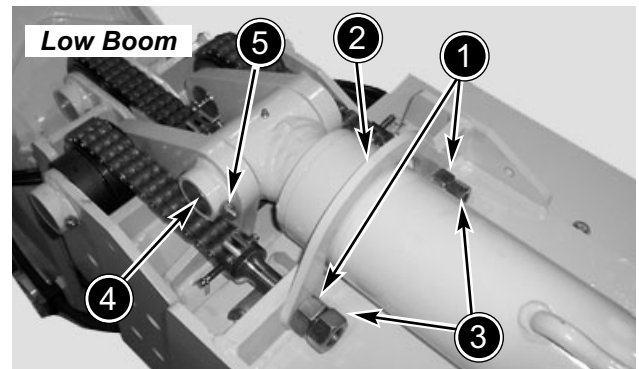

Reinstall the left chain and the two inner nuts (1) to the extend cylinder bracket (2), leave two to three threads extending past each of the chain adjusters. Loosely install the outer two nuts (3). Reinstall the extend cylinder pin (4) and secure with a bolt and lock nut (5). *Skip to Step 41.*

## STEP 39

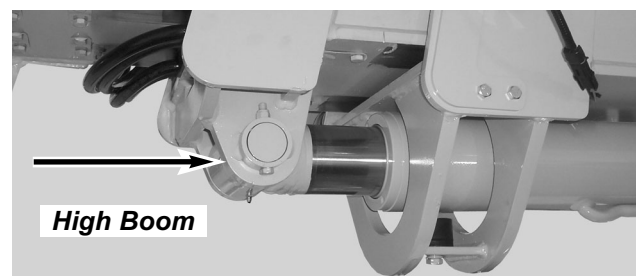

Start the engine, carefully retract the all boom sections into the outer boom and shut off the engine.

## STEP 40

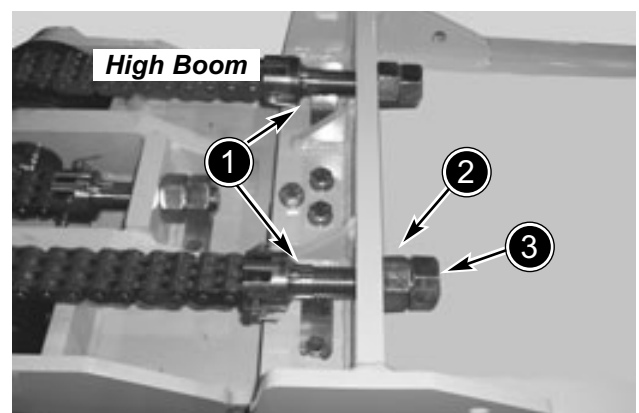

Reinstall the boom chains (1) to the top-front of the outer boom (both sides). Tighten the chain adjuster so that approximately six threads of the chain adjuster extend past the inner nut (2). Loosely tighten the outer nut (3) onto the chain adjusters.

## STEP 41

If not replacing additional slide pads, adjust the boom chains, see Section 724 of this manual for the correct procedure.

# Mustang Telehandler

# BOOM PAD REPLACEMENT

## STEP 83

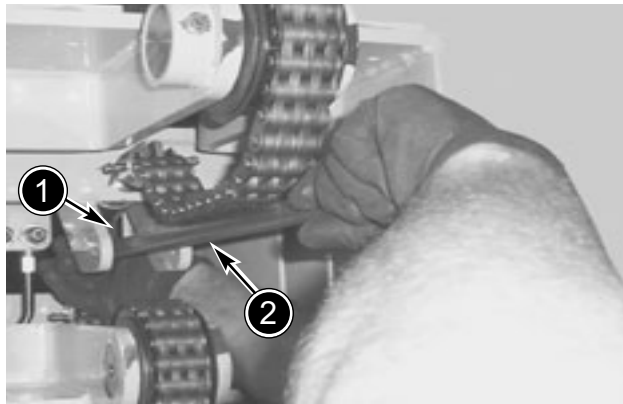

Using a short handle ratchet (1), 1-1/2" deep-well socket and a pry bar (2), tighten the outer nut.

## STEP 84

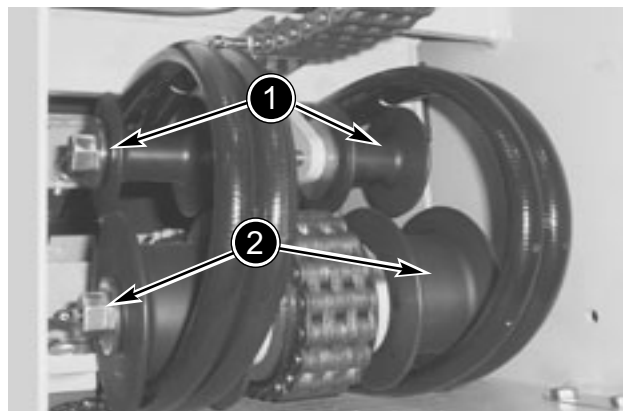

Reinstall the the upper hose guides and bolts (1) (both sides). Use Loctite® 271 (red) Thread Lock (or equivalent) on the threads; do not over tighten. Reinstall the the lower hose guides and bolts (2) (both sides). Use Loctite® 271 (red) Thread Lock (or equivalent) on the threads; do not over tighten.

## STEP 85

Reposition the hoist and lifting strap around the front of the inner boom and push all the boom sections fully into the outer boom.

## STEP 86

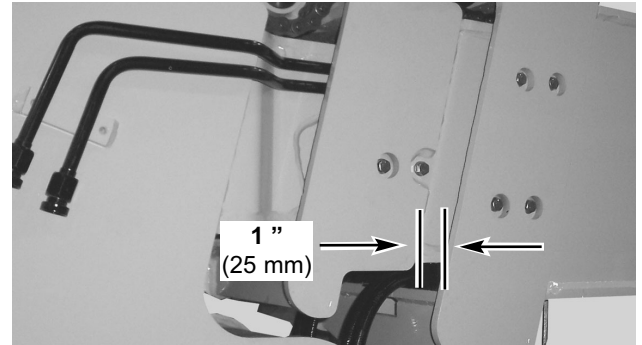

Use a prybar to slide the 2nd intermediate boom section out of the 1st intermediate boom section approximately 1 inch (25 mm).

## STEP 87

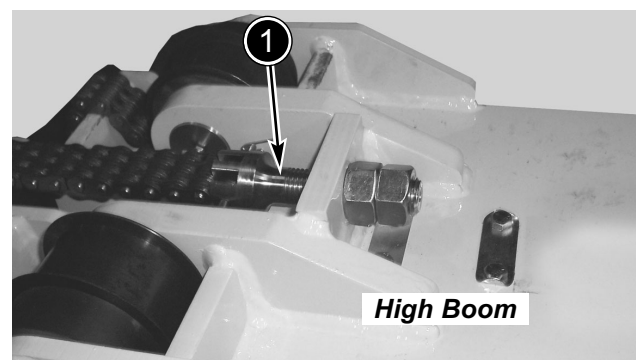
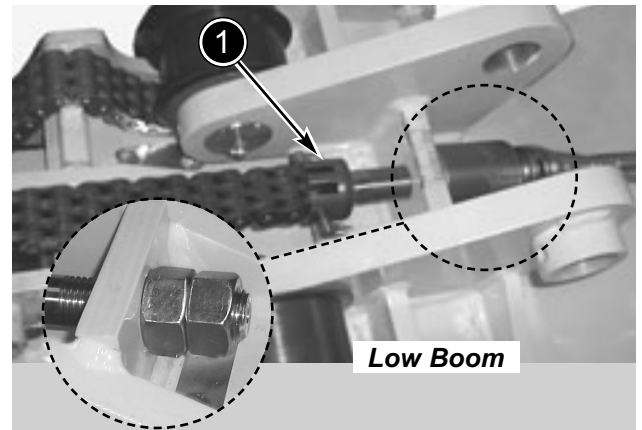

Reinstall the single chain adjuster clevis (1) into the center mount hole of the 1st intermediate boom. Tighten the two chain adjustment nuts so that two or three threads extend past the end of the outer nut (as shown).

## STEP 128

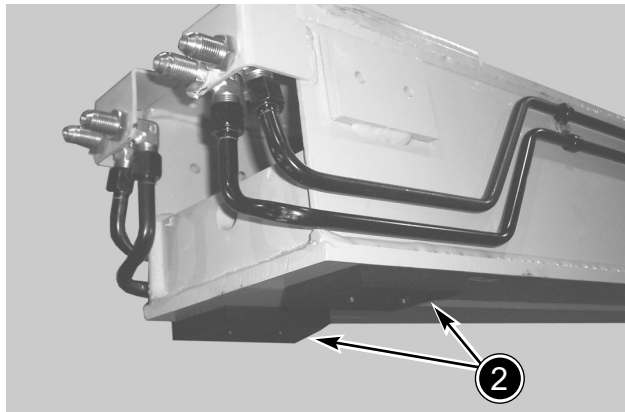
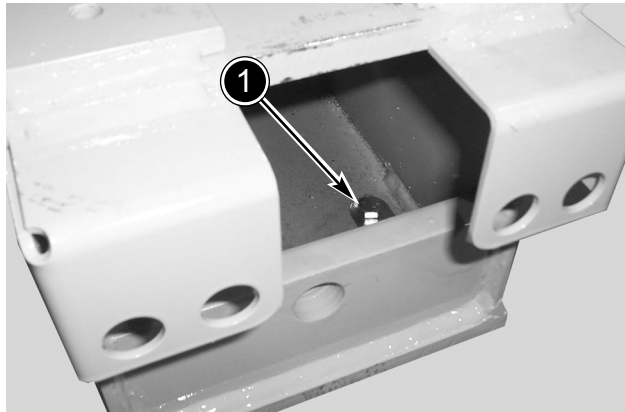

Reinstall the four bolts (1) and two lock plates (not all bolts and lock plates are shown) into the bottom slide pads on the rear of the inner boom. Use Loctite® 271 (red) Thread Lock (or equivalent) on the threads of the bolts and tighten to 30 ft.-lbs. (40 Nm) torque. Bend each end of the lock plates up.

## STEP 129

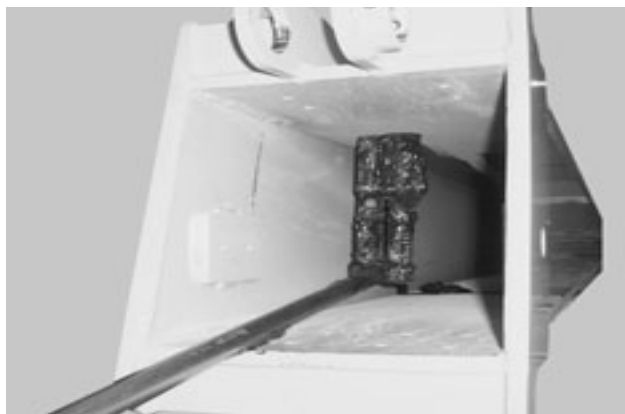

Remove any debris from the inside of the 2nd intermediate boom. Apply grease to the inside bottom and top surfaces. Use a brush attached to a rod or pole to reach inside the boom.

## STEP 130

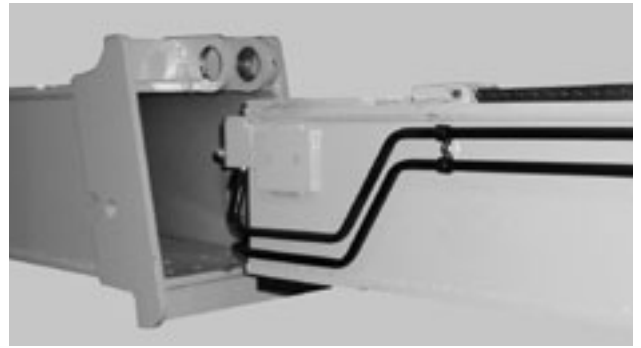

Position the hoist and lifting strap around the center of the inner boom to achieve a balanced lifting point and slide the inner boom into the front of the 2nd intermediate boom section. Reposition the hoist and lifting strap during reinstallation to maintain a balanced lifting point.

## STEP 131

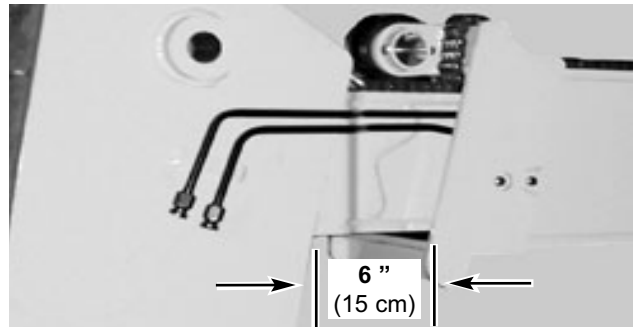

Leave the inner boom extending out of the 2nd intermediate boom approximately 6 inches (15 cm).

## STEP 132

Using the hoist and lifting strap around the front of the inner boom section, apply upward pressure on the 2nd intermediate boom section.

## STEP 133

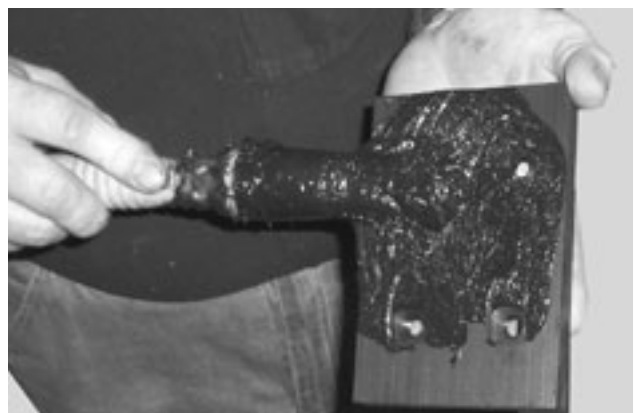

Apply grease to the top of the two bottom slide pads.

## GENERAL INFORMATION

Chain and roller replacement can be accomplished in several ways, depending on the scope of the damage or the reason for replacement.

The top inner boom chain (1) can be replaced in two ways: refer to Section 716 of this manual for the procedure to completely remove the inner boom section, or follow the next steps to replace the top inner boom chain without completely removing the inner boom section.

The following procedures are for high boom and low boom models.

## TOP INNER BOOM CHAIN

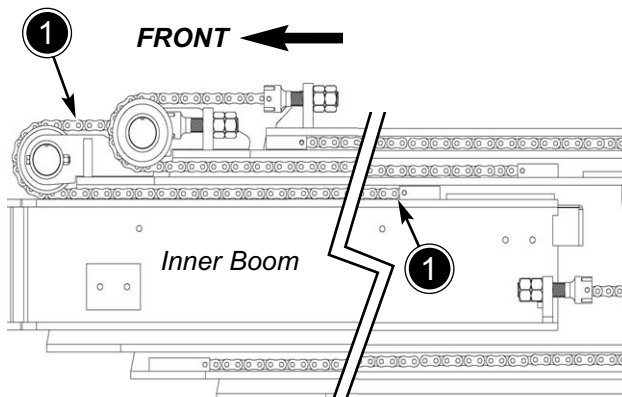
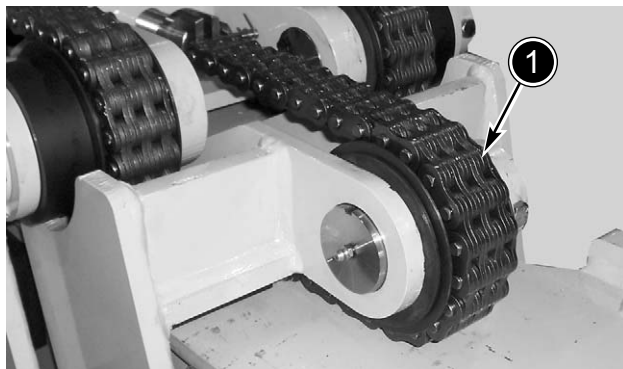

## MANDATORY SAFETY SHUTDOWN PROCEDURE

**BEFORE cleaning, lubricating, or performing service on this equipment:**

1. Bring the machine to a full stop on level surface. (If parking on a slope or hillside cannot be avoided, park across the slope and block the tires.)
2. Fully retract the boom and lower the attachment to the ground.
3. Place controls in NEUTRAL and set park brake.
4. Idle engine for gradual cooling.
5. Turn the starter key switch to OFF position and remove the key (take key with you for security reasons).

**ONLY when you have taken these precautions can you be sure it is safe to proceed. Failure to follow the above procedure could lead to serious personal injury or death.**

**IMPORTANT:** *If the slide pads are to be reused, they must be marked as to location and direction (front/rear/top/bottom) as they are removed. Wire tie the shims with each pad. Slide pads and shims must be reinstalled in the exact original position. Refer to Sections 717 and 718 of this manual for the correct procedure to install new replacement slide pads.*

## TOP INNER BOOM CHAIN REMOVAL

### STEP 1



Park the unit on a solid level surface with adequate room for boom removal. With the engine running, lower the boom and level it according to the boom angle indicator, which should then read 0°.

# **Section**

# **721**

**BOTTOM INNER BOOM CHAIN  
AND ROLLER REPLACEMENT  
4-SECTION HIGH AND LOW BOOM MODELS**

**Mustang Telehandler**

## STEP 43



Reinstall the boom hose clamp (1) on the side of the 1st intermediate boom. Be sure to allow some slack between the boom hose tray and the hose clamp.

## STEP 44

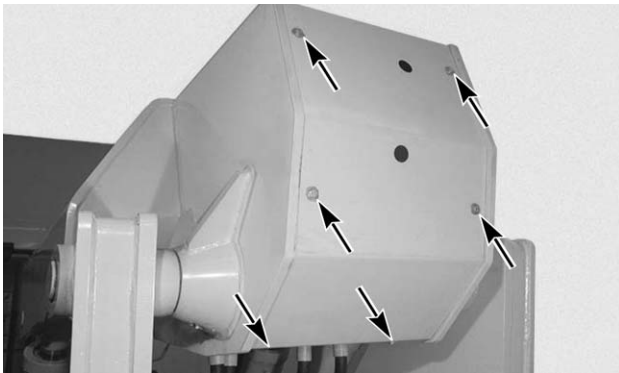

Reinstall the rear boom cover.

## STEP 45

Adjust the boom chains, see Section 724 of this manual for the correct procedure.

# Mustang Telehandler 2ND INTERMEDIATE BOOM CHAIN

## STEP 32

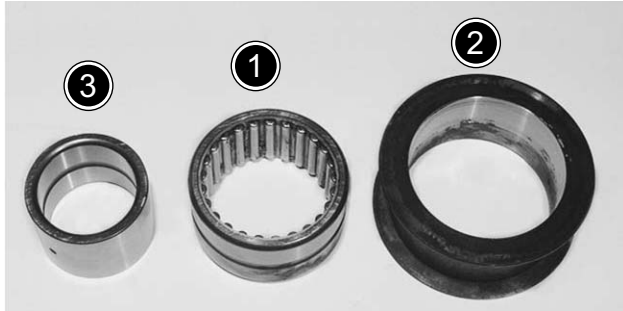

If the roller bearing (1) or sheave (2) do not require replacement, skip to the next step. If replacing the roller bearing (1) or the sheave (2), press the roller bearing in the sheave; center the bearing within the sheave. Apply grease to the inside of the roller bearing and insert the inner ring (3) into the bearing

## STEP 33

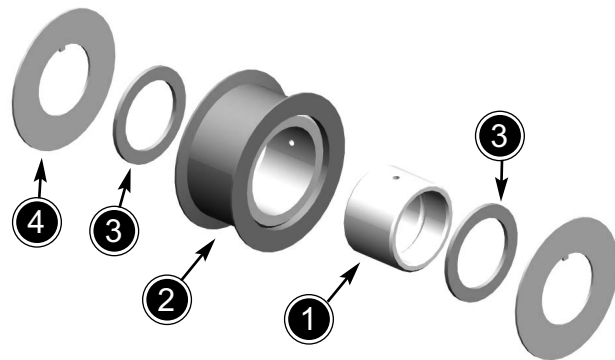

Insert the inner ring (1) into the sheave/bearing assembly (2). Place a spacer (3) and hardened washer (4) on each side of the sheave (2)

## STEP 34

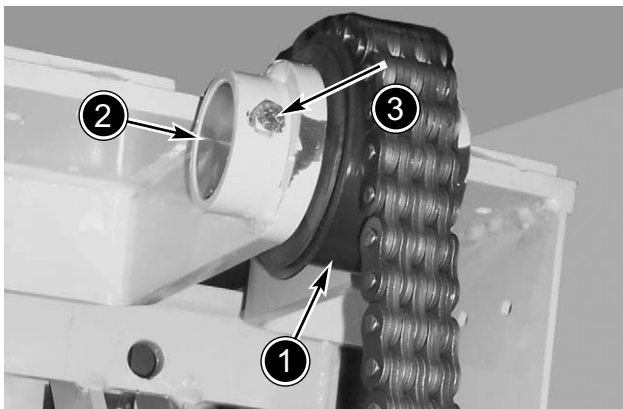

Install the chain roller assembly (1) into the rear mount on the 1st intermediate boom. Be sure to align the tabs on the two outer washers with the groove in the roller pin (2). Secure the roller pin with a bolt and nut (3).

## STEP 35

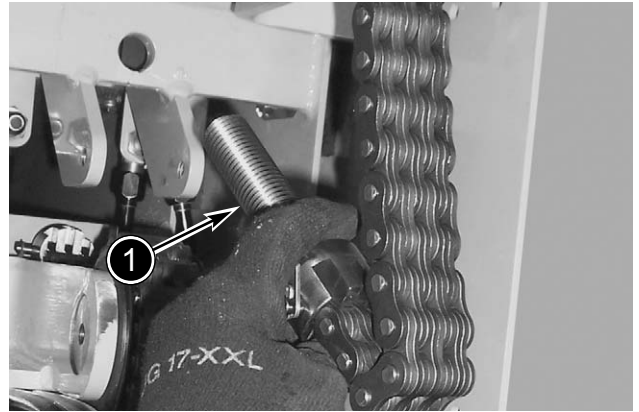

Place the chain adjuster clevis into the upper mounting hole at the rear of the 2nd intermediate boom section.

### High Boom Models

Install the first nut on the the chain adjuster clevis so that 2-7/8 inch (73 mm) of the clevis is extending from the mounting bracket on the 2nd intermediate boom.

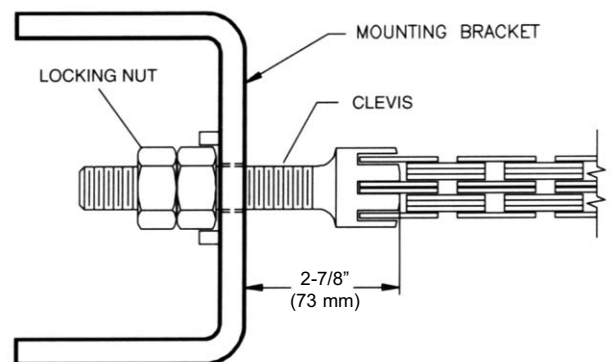

### Low Boom Models

Install the first nut on the the chain adjuster clevis so that 3-3/8 inch (85 mm) of the clevis is extending from the mounting bracket on the 2nd intermediate boom.

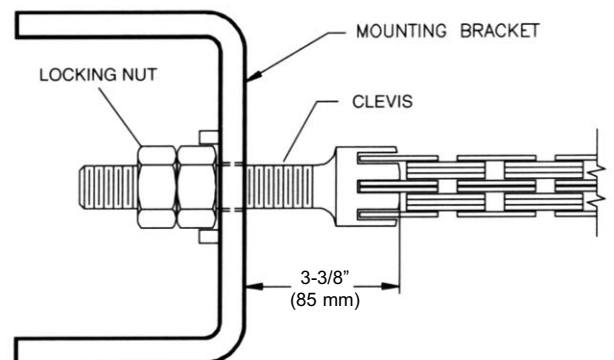

## BOOM CHAIN ROLLER BEARING REPLACEMENT

### STEP 1



With the engine running, lower the boom and level it according to the boom angle indicator, which should then read 0°. Shut off the engine; follow the Mandatory Safety Shutdown Procedure.

## MANDATORY SAFETY SHUTDOWN PROCEDURE

**BEFORE** cleaning, lubricating, or performing service on this equipment:

1. Bring the machine to a full stop on level surface. (If parking on a slope or hillside cannot be avoided, park across the slope and block the tires.)
2. Fully retract the boom and lower the attachment to the ground.
3. Place controls in NEUTRAL and set park brake.
4. Idle engine for gradual cooling.
5. Turn the starter key switch to OFF position and remove the key (take key with you for security reasons).

**ONLY** when you have taken these precautions can you be sure it is safe to proceed. Failure to follow the above procedure could lead to serious personal injury or death.

### STEP 2

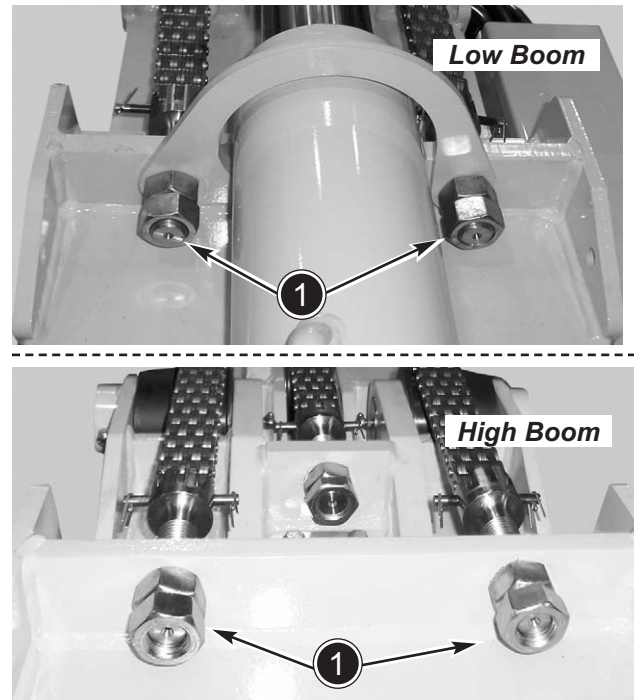

Remove the four nuts (1) that secure the chain adjusters to the outer boom. Remove the chain adjusters and chain from the outer boom and hang both chains over the front of the inner boom.

### STEP 3

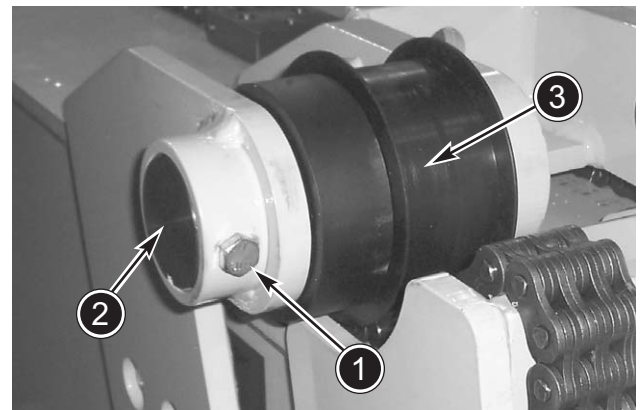

Remove the retaining bolt (1) and nut from both chain roller mounts. Remove the chain roller pin (2) and the chain roller bearing assembly (3), spacer and washers (both sides).

# **Section**

# **801**

## **RADIATOR REMOVAL AND INSTALLATION**

### **Mustang Telehandler**

CLICK HERE TO **DOWNLOAD** THE COMPLETE MANUAL

- Thank you very much for reading the preview of the manual.
- You can download the complete manual from: [www.heydownloads.com](http://www.heydownloads.com) by clicking the link below



- Please note: If there is no response to CLICKING the link, please download this PDF first and then click on it.

CLICK HERE TO **DOWNLOAD** THE COMPLETE MANUAL