

2066



2076

2086

**SKID-STEER
LOADER**

**SERVICE
MANUAL**

Revision A - 01/05

PART #917098



Mustang Manufacturing Company, Inc.

CLICK HERE TO **DOWNLOAD** THE COMPLETE MANUAL

- Thank you very much for reading the preview of the manual.
- You can download the complete manual from: www.heydownloads.com by clicking the link below



- Please note: If there is no response to CLICKING the link, please download this PDF first and then click on it.

CLICK HERE TO **DOWNLOAD** THE COMPLETE MANUAL



Fig. 2-1 The lock pin secures the liftarm support device underneath the left liftarm.



Fig. 2-2 Flip lock pin down and grab with finger.



Fig. 2-3 Pull ring out of welded post.

Liftarm Support Device

! WARNING

BEFORE leaving the operator's compartment to work on the loader with the liftarm raised, **ALWAYS** engage the liftarm support device. Turn the keyswitch to OFF, remove the key and take it with you.

Many service procedures require a raised liftarm to allow easier access to loader components. For operator and service personnel safety, a liftarm support device is standard on Mustang skid-steer loaders. Used as a cylinder block, it is intended to prevent a raised liftarm from unexpectedly lowering.

BE SURE to engage the liftarm support device whenever the liftarm is raised. When the device is not being used, secure it to the anchor on the underside of the liftarm using the lock pin and retainer provided.

The liftarm support device is a safety device, which must be kept in proper operating condition at ALL times.

The following procedures outline the correct way to engage and disengage the liftarm support device.

Liftarm Support Device Engagement

1. Lower liftarm until contact with loader frame.
2. Turn the keyswitch to the OFF position to stop the engine.
3. Leave operator's compartment. Flip lock pin ring down and pull out of welded post to release its locking mechanism. Allow support device to come down into contact with lift cylinder. **Figs. 2-1, 2-2 and 2-3**
4. Return to the operator's compartment and restart the engine.
5. Use lift control to raise liftarm until lift arm support device drops over the end of the lift cylinder and around cylinder rod. Slowly lower liftarm until free end of support device contacts top end of lift cylinder. **Fig. 2-4**
6. Make sure the support device is secure against the base end of the lift cylinder. Then, stop the loader engine, remove the key and leave the operator's compartment.

Introduction

Mustang 2066/76/86 skid-steer loaders have a welded steel chassis. Maintenance, service and repair may be performed through standard access panels.

Two side cases provide mounting for the drive motors and for the front and rear axles. The side cases also serve as sealed housings for the drive chains and sprockets. Oil is used inside these cases to ensure the chains always receive proper lubrication.

The liftarm and the lift and tilt cylinders are mounted with pivot pins. Capscrews are used to secure the pivot pins. A Rollover Protective Structure/Falling Object Protective Structure (ROPS/FOPS) is standard for operator safety, and both the seat and restraint bar include interlock switches.

Rollover & Falling Object - Protective Structure (ROPS/FOPS) Components

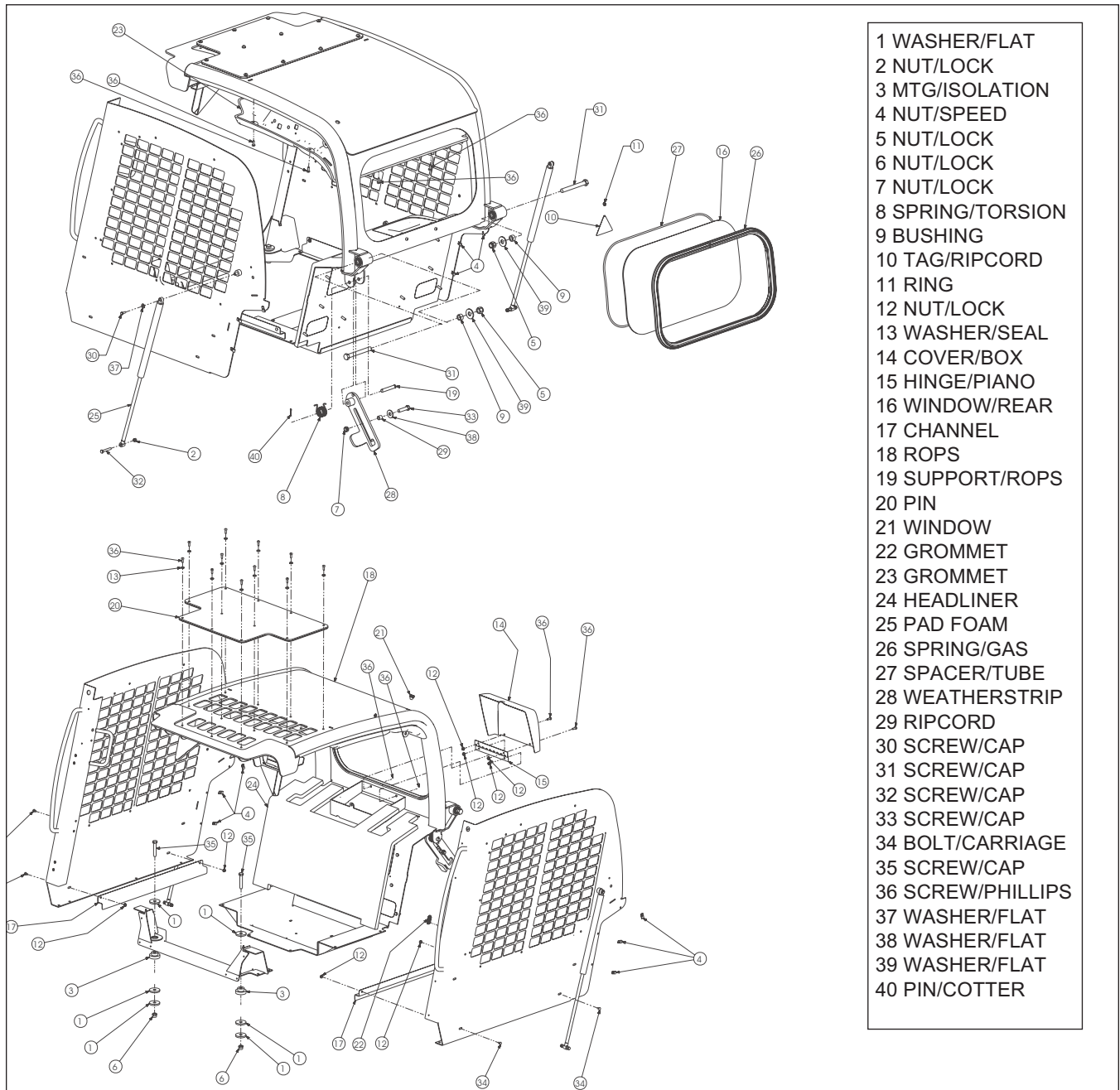

Fig. 4-1 Exploded view of ROPS/FOPS components.

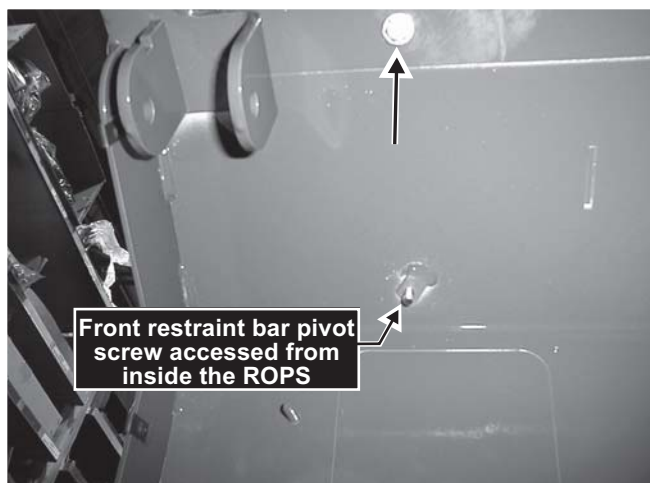

Fig. 4-23 Location of capscrew securing the rear of the restraint bar pivot underneath the ROPS frame. View is from underneath ROPS.

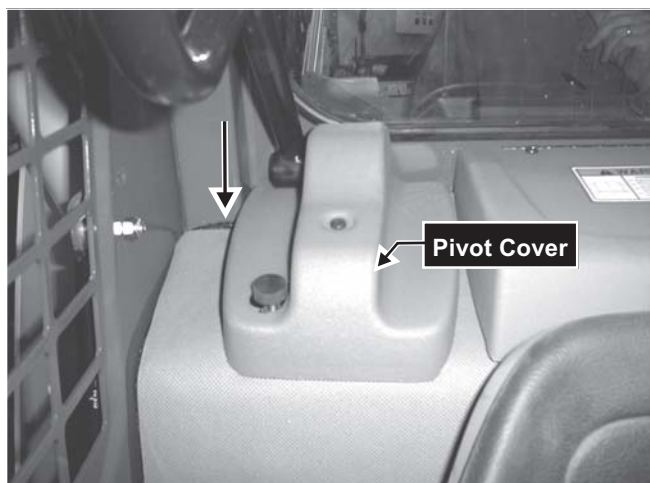

Fig. 4-24 Location of restraint bar switch wire connected to wire harness.

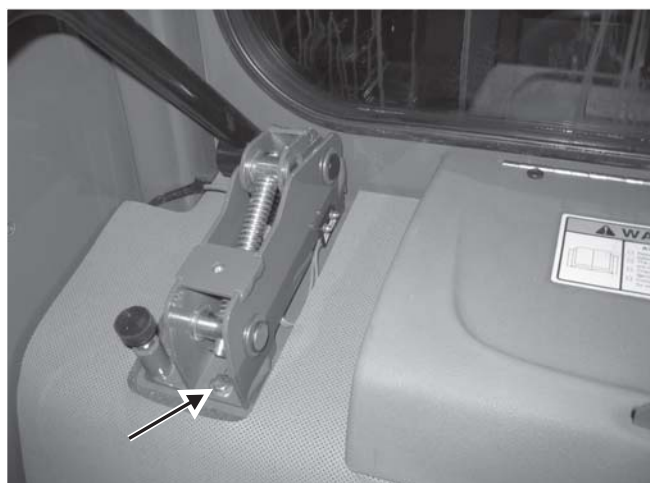

Fig. 4-25 Location of screw securing front of right restraint bar pivot to the ROPS.

Restraint Bar Removal and Installation

Removal Procedure

1. Raise engine cover.
2. Underneath the ROPS, remove screw securing the rear of the restraint bar pivot. **Fig. 4-23**
3. Inside ROPS, remove one screw securing pivot cover and remove cover. **Fig. 4-24**
4. Disconnect restraint bar switch from wire harness located above restraint bar on right side. **Figs. 4-24, 4-25**
5. Remove one screw on each side securing front of restraint bar pivot to ROPS. Lift restraint bar up and out of loader. **Figs. 4-25, 4-26**

NOTE: For restraint bar switch removal, refer to the *Electrical* chapter.

Installation Procedure - Reverse the removal steps

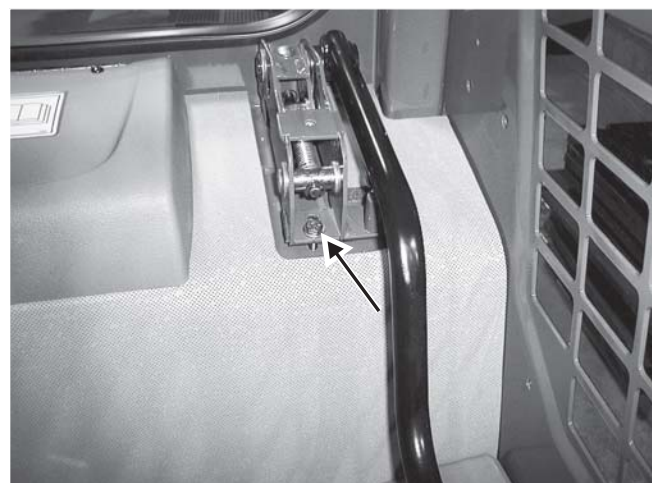

Fig. 4-26 Location of screw securing front of left restraint bar pivot to the ROPS.

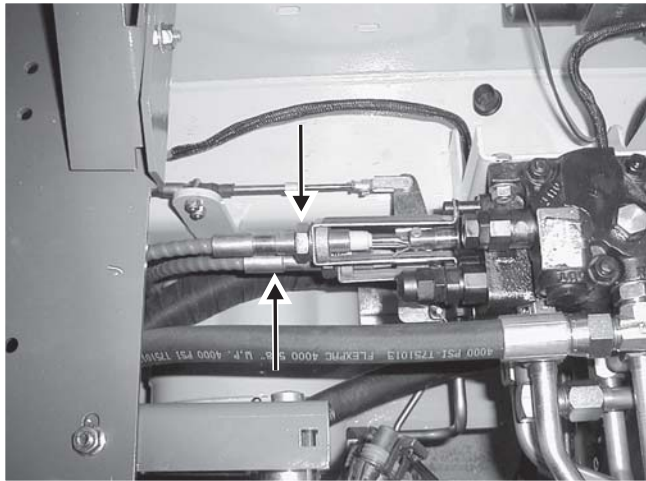

Fig. 4-54 Dual Hand Controls: Location of lift and tilt control cables connected to cable brackets at the control valve.

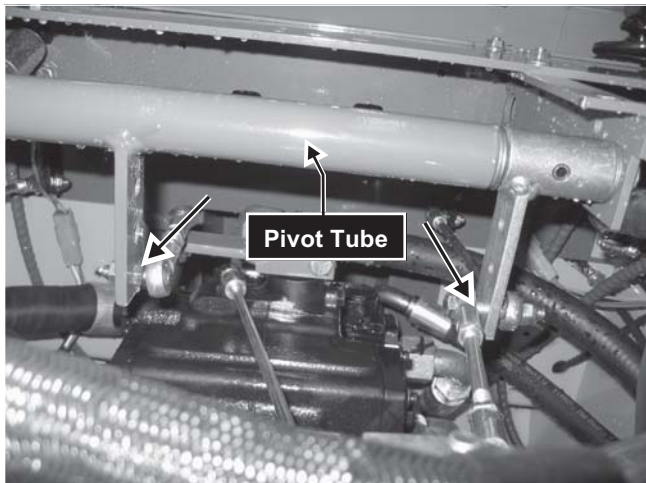

Fig. 4-55 Disconnect wheel drive control rods at pivot tube.

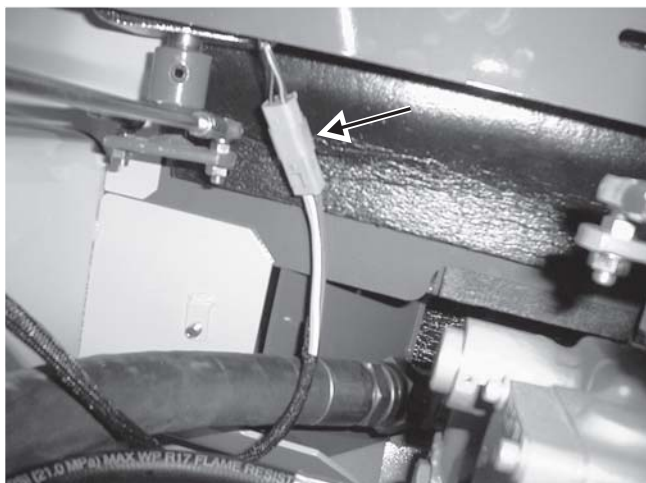

Fig. 4-56 Control handle electrical connector underneath the crossmember.

8. With an assistant's help, carefully lift the crossmember out of the chassis.

Installation Procedure - Follow all warnings first, then reverse the removal steps.

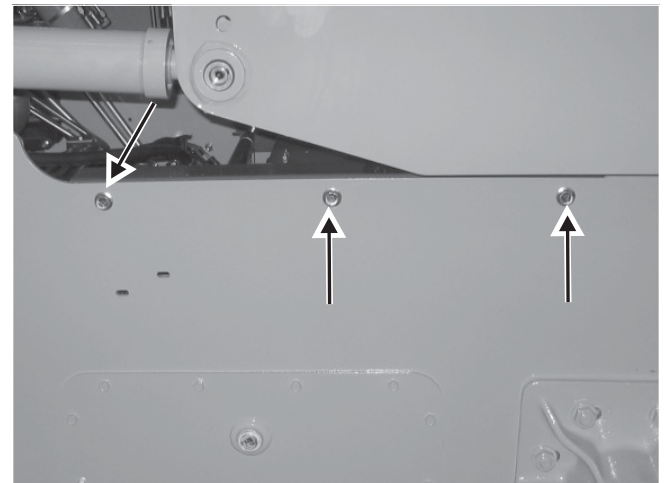

Fig. 4-57 Location of three capscrews securing the ROPS filler panels on inside wall of chassis.

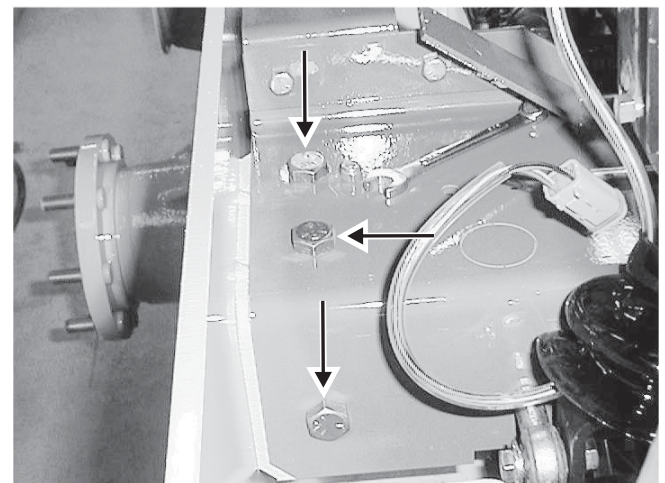

Fig. 4-58 Three capscrews securing crossmember on right side. Left side same.

4. Place axle shaft on flat surface with the shaft in a vertical position. Press bearing cone onto the axle shaft with a suitable driver. Note orientation of the first bearing cone in **Figs. 5-16 and 5-17**.

5. Insert axle shaft into axle housing. **Fig. 5-17**

NOTE: Allowable end play tolerance on axle shaft is 0.000" to 0.005" (0.0 mm to 0.127 mm) with axle turning freely. Add shims to increase end play or remove shims to decrease end play.

6. Install inner bearing cone and special washer(s). **Figs. 5-18, 5-19, 5-20**

7. Seat external retaining ring in axle shaft groove. **Fig. 5-21**

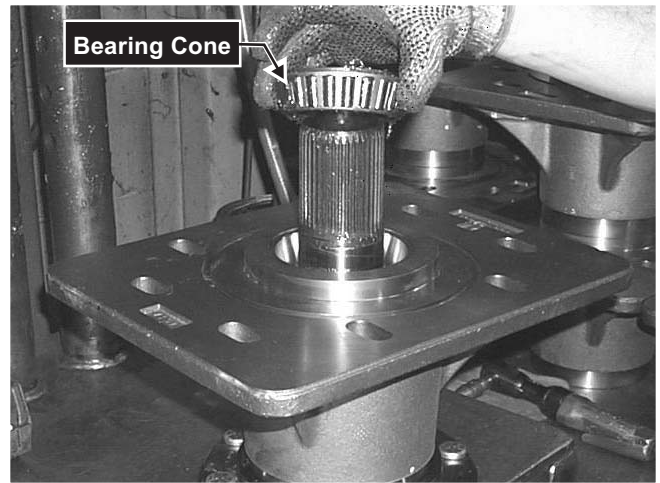

Fig. 5-18 Press the second bearing cone onto the axle shaft.

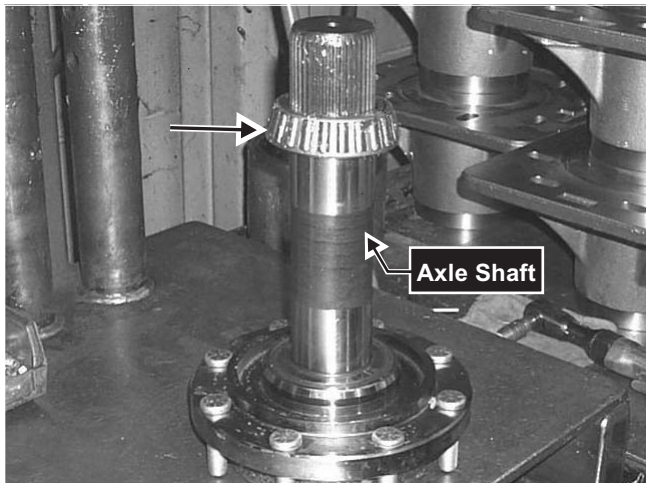

Fig. 5-16 Press the bearing cone onto the axle shaft. Note orientation of bearing cone.

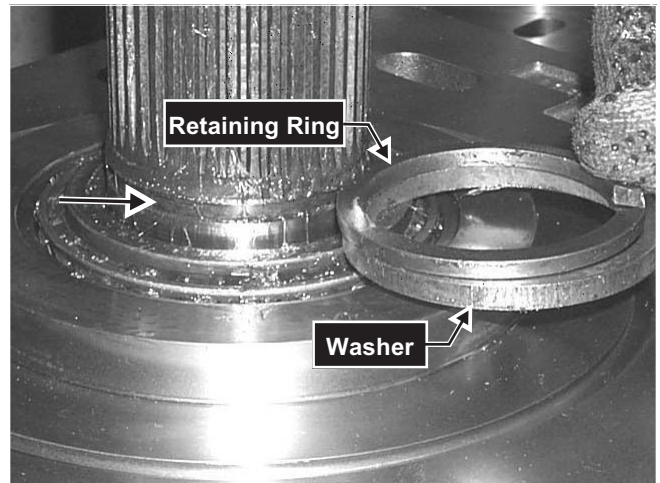

Fig. 5-19 Location of groove on axle shaft.

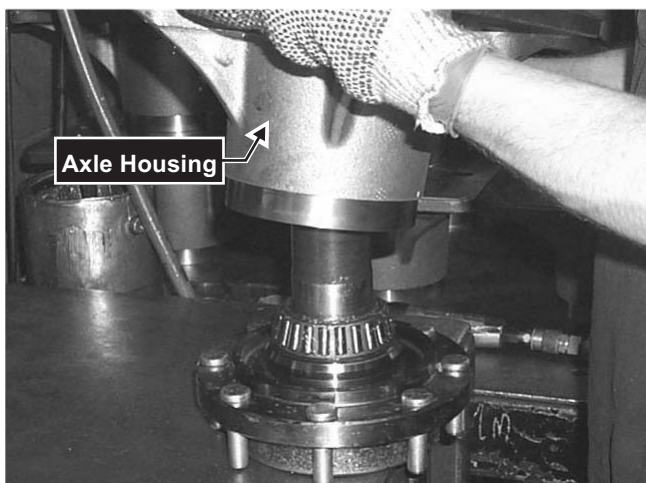

Fig. 5-17 Slide the axle housing over the axle shaft.

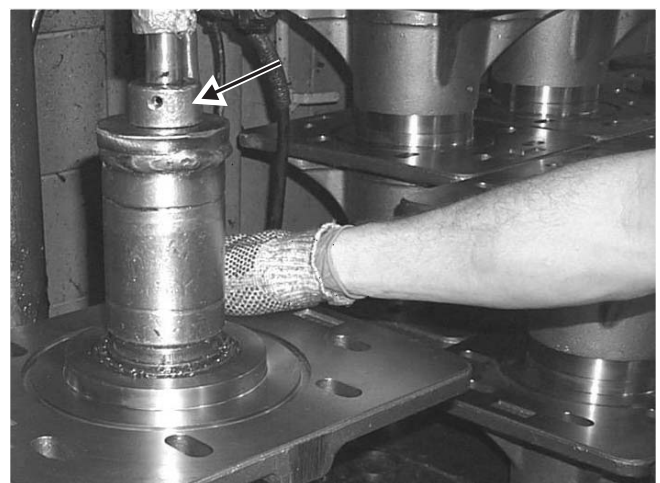

Fig. 5-20 Pressing special washers onto axle shaft.

WHEEL DRIVES



Fig. 6-16 The left and right control handle pivots are identical.

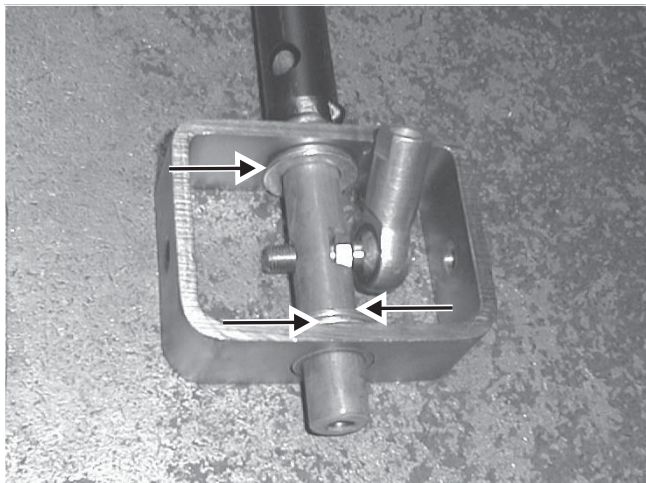

Fig. 6-17 Location of three washers on right T-Bar pivot. Washer location is same on left T-Bar pivot.

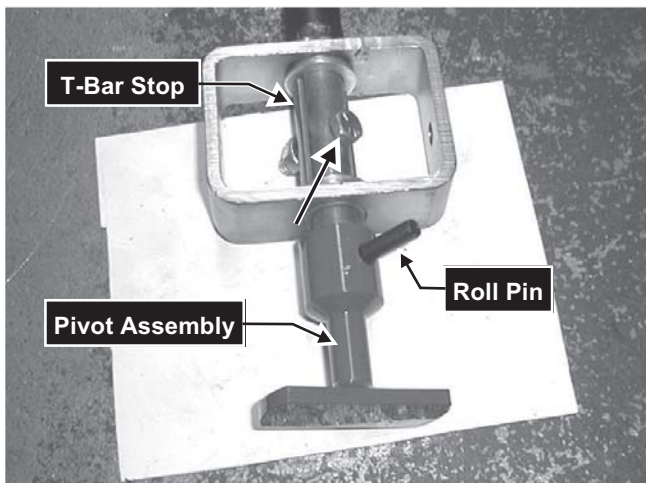

Fig. 6-18 Location of capscrew used to secure the t-bar stop on the left T-Bar pivot.

T-Bar Control Handle Assembly

Assembly Procedure

The left T-Bar control handle operates the traction functions for the left and right side of the skid-steer loader. There is also a button switch for the horn in the grip assembly. On two-speed models, a button switch in the grip assembly controls the speed of the loader.

The right T-Bar control handle operates the lift and tilt functions for the skid-steer loader. There is also a button switch for the Hydraglide™ Ride Control option in the grip assembly.

NOTE: The left T-Bar is identical to the right T-Bar except that a different lower pivot is used on each.

1. Slide boot up T-Bar control handle.
2. Press or drive two bronze bearings into holes on pivot. Use a bearing driver, if available. **Fig. 6-16**
3. Place top half of pivot and three washers on control handle, then slide handle through pivot. **Fig. 6-17**
4. Place T-Bar stop between washers: **Figs. 6-17, 6-18, 6-19**
 - a. **Left T-Bar:** Secure to pivot with capscrew and locknut. Press pivot assembly on bottom of control handle and secure with roll pin.
 - b. **Right T-Bar:** Secure with studded rod end, placed in recessed area, and jam nut. Install spacers above and below lift control rod end and secure in control handle with a capscrew.
5. Attach elastomeric rod ends to sides of pivot with capscrews, washers and locknuts. **Fig. 6-20**

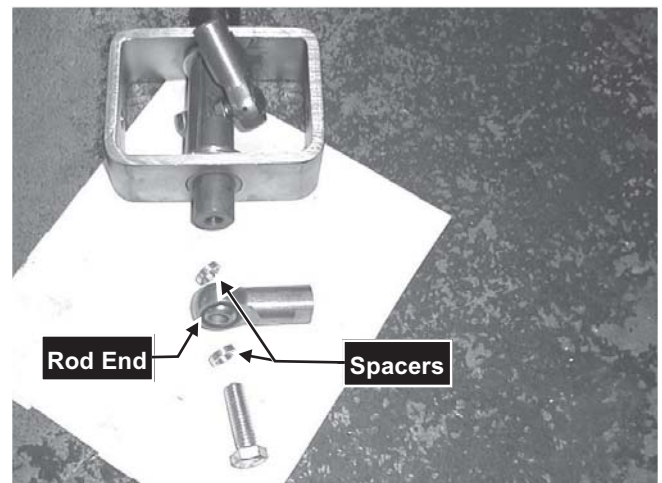

Fig. 6-19 Capscrew secures rod end and spacers at bottom of right T-Bar control handle.

CONTROLS

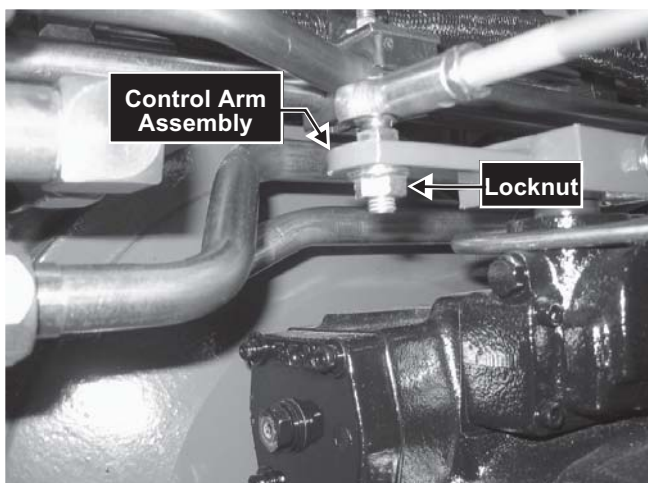

Fig. 6-47 View of locknut securing control rod to control arm assembly.

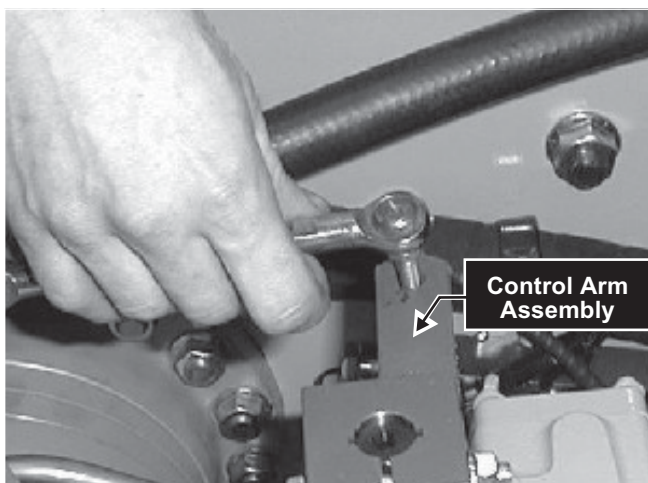

Fig. 6-48 Remove control arm assembly from hydrostatic pump shaft.

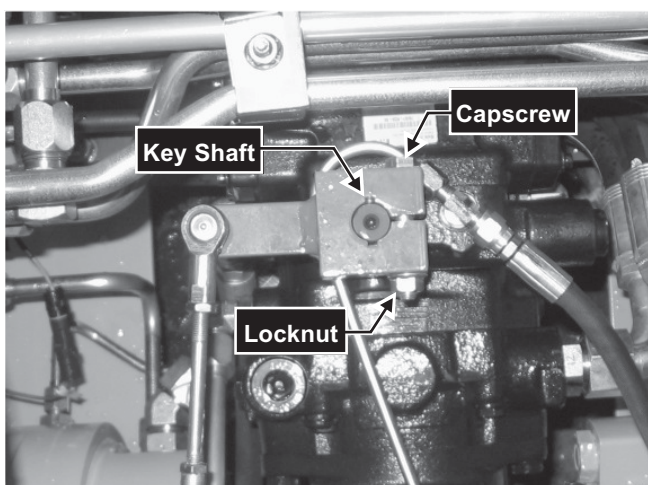

Fig. 6-49 Remove/install pump arm to hydrostatic pump shaft. Retain the keys when lifting control arm off the pump shaft.

Control Arm Assembly Removal and Installation

Removal Procedure

WARNING

BEFORE beginning this service procedure, perform the following **SAFETY** procedures:

- Raise liftarm, engage liftarm support device.
- Shut off the engine.
- Roll ROPS back until lock engages.

(For detailed instructions, refer to the **Safety** chapter of this manual.)

1. Remove the locknut on each rod end attached to the two control arm assemblies and slide rod ends out of the control arms. **Fig. 6-47 and 6-48**
2. Remove the capscrew and locknut that clamps the control arm assembly to the hydrostatic pump shaft. **Fig. 6-49**
3. Slide the control arm assembly off the hydrostatic pump shaft. Take the small key off the shaft (use caution not to lose it). **Fig. 6-49**

Installation Procedure - Follow all warnings first, then reverse the removal steps.*

* It may be necessary to perform the neutral centering device adjustment to locate “true neutral” after installation of the control arms, BUT, if the control rods’ lengths were not altered and the rod ends slip right in, or, if only a very slight adjustment is made to fit the rod end in the control arm assembly, no adjustment should be necessary.

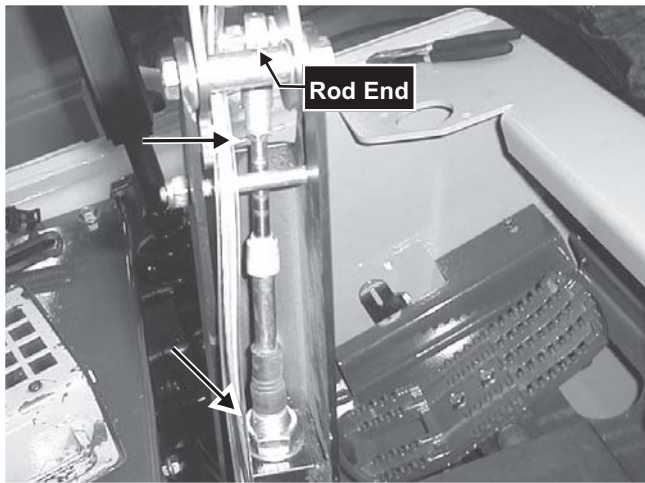

Fig. 6-71 Location of the two jam nuts on the auxiliary hydraulics cable in the control handle.

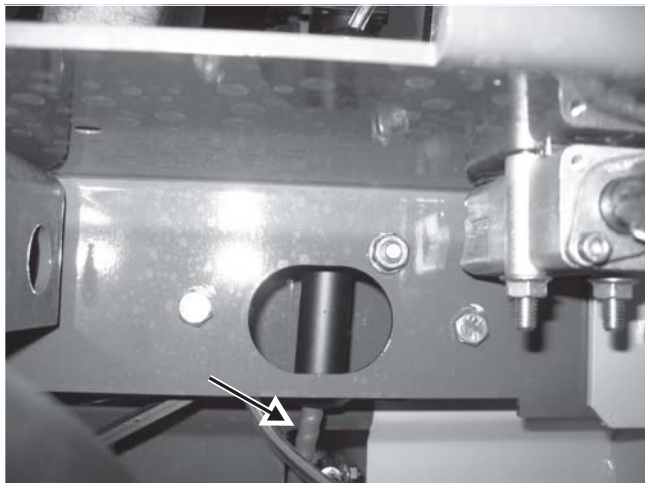

Fig. 6-72 Location of cable in lower handle.

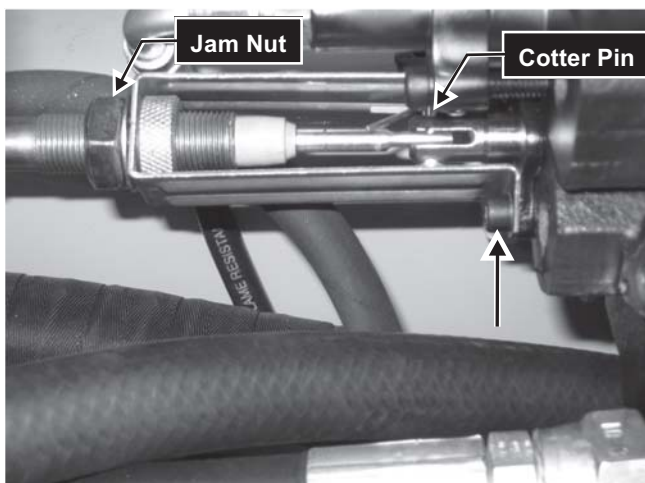

Fig. 6-73 Location of hex-head machine screw securing cable mount to control valve.

Auxiliary Hydraulics Cable Removal and Installation - Hand/Foot

Removal Procedure - Hand/Foot Controls

WARNING

BEFORE beginning this service procedure, perform the following **SAFETY** procedures:

- Raise liftarm, engage liftarm support device.
- Shut off the engine.
- Roll ROPS back until lock engages.

(For detailed instructions, refer to the **Safety** chapter of this manual.)

1. Remove capscrew, locknut and two washers on rod end inside control handle. Loosen jam nut on rod end and remove rod end from cable. **Fig. 6-71**
2. Remove jam nut on cable in lower handle of control handle. **Fig. 6-71**
3. Pull auxiliary cable down through control handle. **Fig. 6-72**
4. At control valve, loosen jam nut on cable mount. **Fig. 6-73**
5. Remove two hex-head machine screws on cable mount. **Fig. 6-73**
6. Remove cotter pin securing auxiliary hydraulics cable to auxiliary spool valve. **Fig. 6-73**
7. Remove auxiliary control cable from loader.

Installation Procedure - Hand/Foot Control - Follow all warnings first, then reverse the removal steps.*

* For cable adjustment, refer to the "Auxiliary Hydraulics Cable Adjustment" procedure in this chapter.

Introduction

This chapter covers troubleshooting, testing, removal, installation, and adjustment procedures for the hydrostatic system components on Mustang 2066/76/86 skid-steer loaders.

In this system, a hydrostatic pump assembly coupled to the engine provides hydrostatic power to the two fixed-displacement hydrostatic drive motors. The drive motors drive the wheels on each side of the loader through a chain and sprocket system. The hydrostatic pumps and drive motors are controlled individually

allowing complete flexibility in forward, reverse, gradual, pivot and spin turns.

For detailed information on hydrostatic pump or drive motor internal repair, consult the Mustang Service Department and/or the hydrostatic component manufacturer's service manual. Other related hydraulic components are covered in the *Hydraulic System* chapter of this manual.

Hydrostatic System - 2066/76/86 Single-Speed Model Components

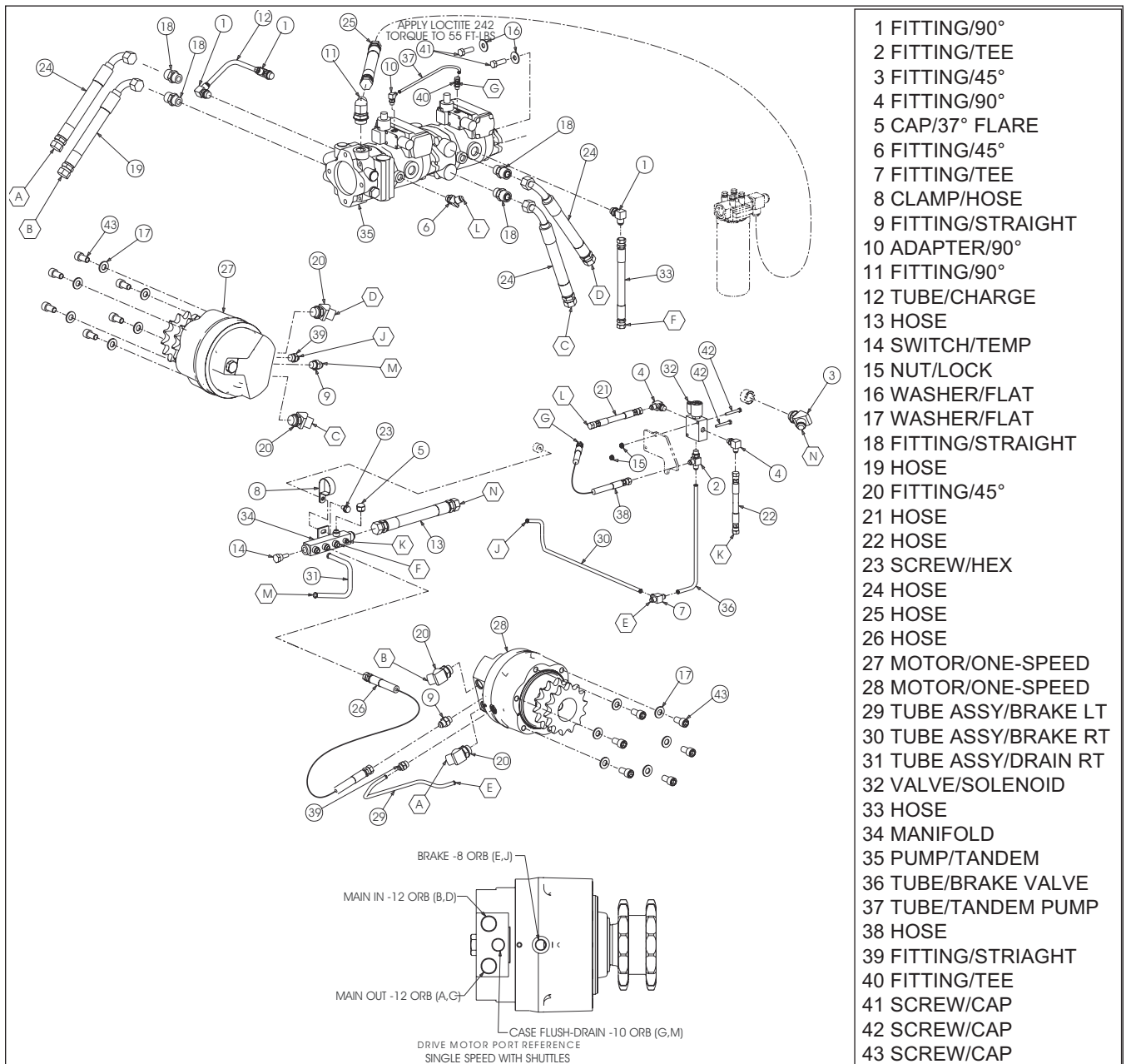

Fig. 7-1 Exploded view of the hydrostatic single-speed system.

CLICK HERE TO **DOWNLOAD** THE COMPLETE MANUAL

- Thank you very much for reading the preview of the manual.
- You can download the complete manual from: www.heydownloads.com by clicking the link below



- Please note: If there is no response to CLICKING the link, please download this PDF first and then click on it.

CLICK HERE TO **DOWNLOAD** THE COMPLETE MANUAL

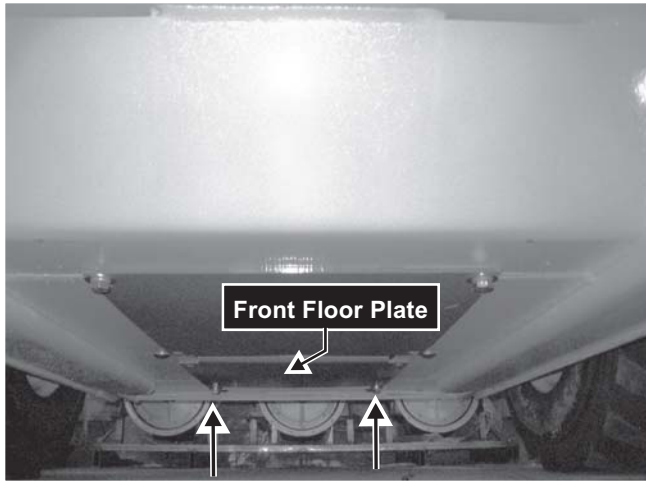

Fig. 7-14 Location of capscrews securing the front floor plate to the chassis. (View is from underneath looking forward.)



Fig. 7-15 Remove chaincase cover to access drive chains on both sides of the loader.

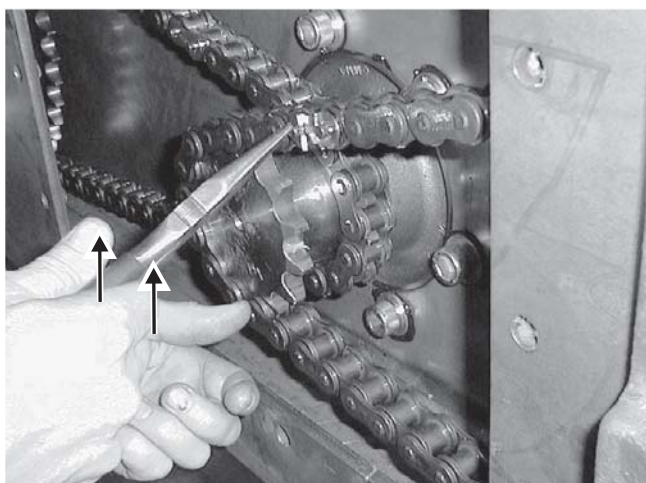

Fig. 7-16 Remove drive chains from drive motor at the connector links.

Drive Motor Removal and Installation

Removal Procedure

⚠ WARNING

BEFORE beginning this service procedure, perform the following **SAFETY** procedures:

- Raise liftarm, engage liftarm support device.
- Shut off the engine.
- Roll ROPS back until lock engages.
- Raise and securely block the loader so all four tires are off the ground.

(For detailed instructions, refer to the *Safety* chapter of this manual.)

1. Remove two capscrews securing front floor plate, then remove floor plate from chassis. **Fig. 7-14**
2. Remove drive chains per the procedure in the *Wheel Drives* chapter. **Figs. 7-15, 7-16**
3. If necessary, drain oil from hydraulic reservoir per the procedure in the *Hydraulic System* chapter. **Fig. 7-22**

NOTE: If the hydraulic hoses and tubes are plugged after removal to prevent oil leakage, it should not be necessary to drain the hydraulic reservoir. Hydraulic hoses and tubes should be plugged to prevent contaminants from entering the hydraulic system.

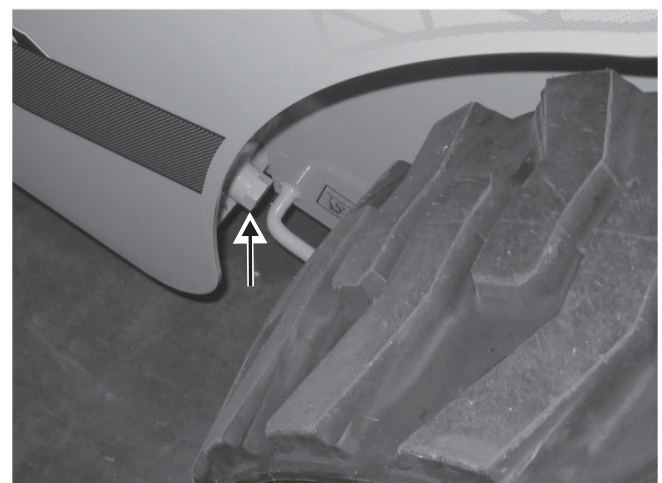
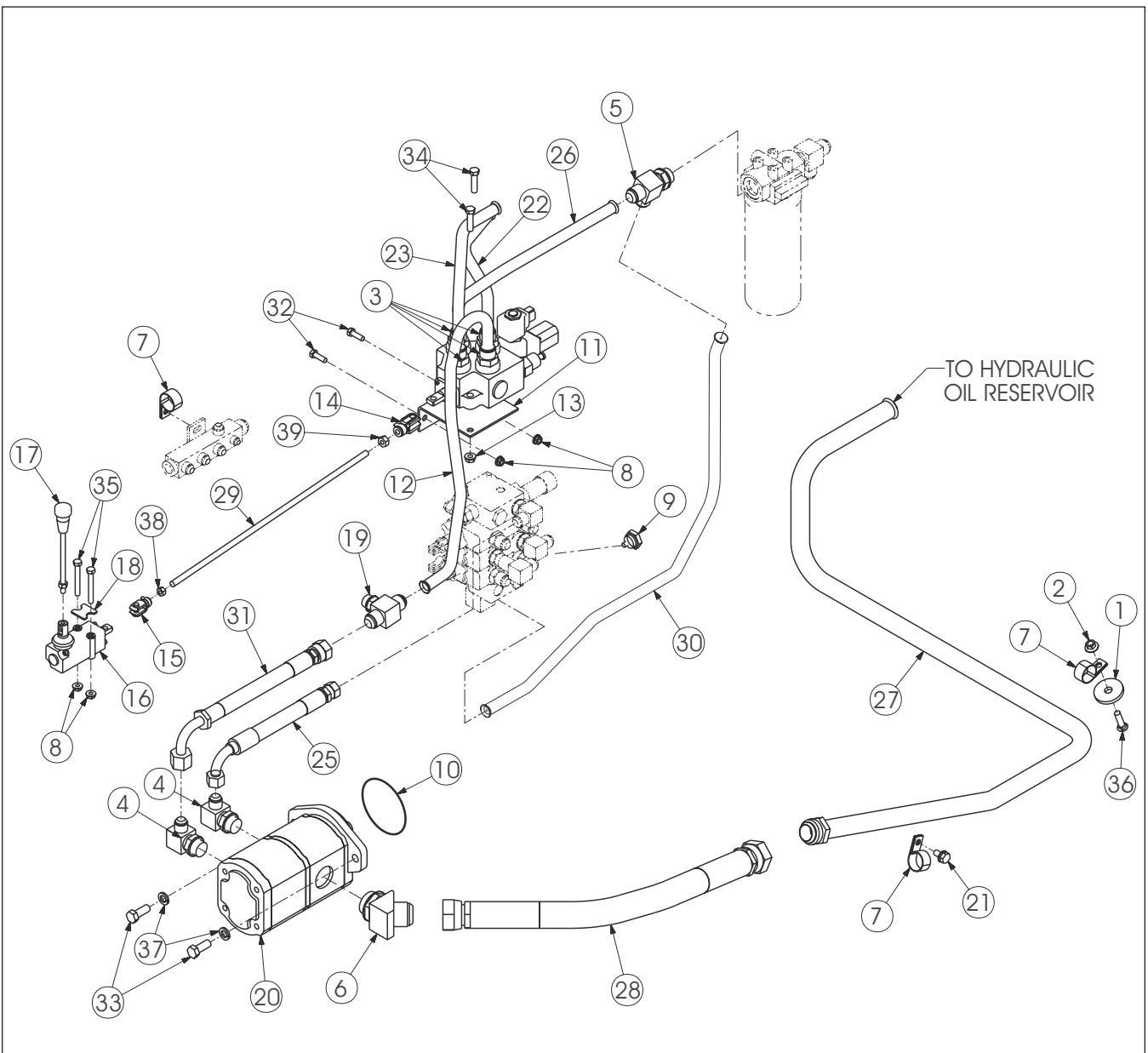

Fig. 7-17 Location of hydraulic oil reservoir drain plug behind right rear tire.

HYDROSTATIC

Hydraulic System - High-Flow Auxiliary Components - 2066/76/86 Models



1 WASHER/FLAT	11 BRACKET/VALVE	21 SCREW/CAP	31 HOSE/PRESSURE
2 NUT/HEX	12 TUBE/HIGH FLOW	22 TUBE/HIGH FLOW	32 SCREW/CAP
3 FITTING/STRAIGHT	13 NUT/LOCK	23 TUBE/HIGH FLOW	33 SCREW/CAP
4 FITTING/90°	14 CLEVIS	24 VALVE/HIGH FLOW	34 SCREW/CAP
5 FITTING/TEE	15 PIN/SPRING	25 HOSE/PRESSURE	35 SCREW/CAP
6 FITTING/45°	16 BOX/LEVER PIVOT	26 TUBE/HIGH FLOW	36 BOLT/CARRIAGE
7 CLAMP/HOSE	17 LEVER/HAND	27 TUBE ASSY/SUCTION	37 WASHER/LOCK
8 NUT/LOCK	18 SPACER	28 HOSE ASSY/SUCTION	38 NUT/HEX
9 PLUG/POWER	19 FITTING/TEE	29 ROD/CONTROL	39 NUT/HEX
10 O-RING	20 PUMP/GEAR	30 TUBE/RETURN	

Fig. 8-5 Exploded view of the high-flow auxiliary hydraulic system.

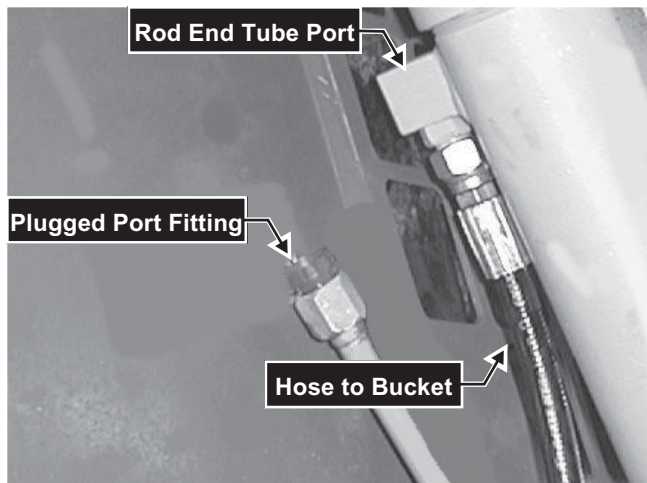

Fig. 8-22 Attachment up and rolled forward for the solenoid valve test.

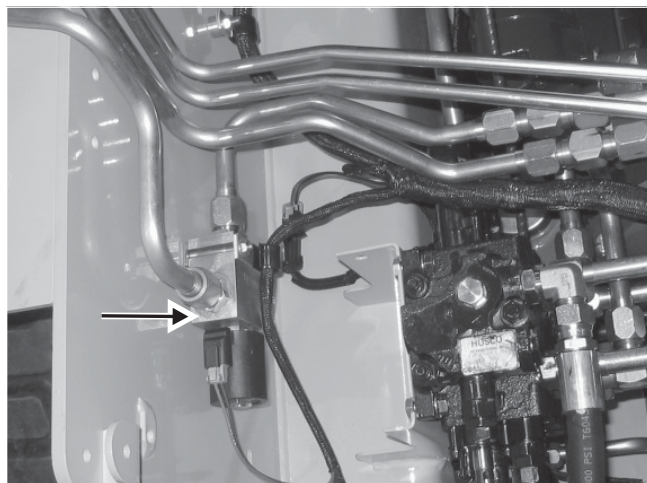

Fig. 8-23 Location of the tilt solenoid.



Fig. 8-24 Location of the lift solenoid (2086 Models).

8. Lower the liftarm support device back against the lift cylinder. Shut off the engine and move the lift control back and forth (up and down) to relieve hydraulic pressure.

9. Reconnect the hydraulic tube to the cylinder, then reattach the clamp around the hydraulic tubes and cylinder.

NOTE: If neither lift cylinder shows signs of external or internal leakage, and the liftarm still settles, the problem could be due to leaking hydraulic hose fittings between the control valve and the lift cylinders. Check all hydraulic hose fittings thoroughly. The fault could also be in either the control valve or the self-leveling valve. Continue the procedure with step 11. Also refer to the Troubleshooting Guide in this chapter.

10. The other lift cylinder may be checked in the same manner.

11. To determine if either the control valve or the self-leveling valve is faulty, perform the “Self-Leveling Valve Test” procedure in this chapter.

Solenoid Valve Test - Tilt, Lift, Brake and Two-Speed

During normal operations, the solenoid valves should prevent operation of the liftarm and drive functions if any of the safety interlocks are open, for example:

- ✗ Operator not sitting on loader seat.
- ✗ Restraint bar not lowered in front of operator.
- ✗ Optional front door is open.

Test Procedure

1. Climb into the operator’s seat, lower the restraint bar and start the engine.
2. Using the lift control, raise the liftarm off the ground enough so that the attachment can be tilted.
3. Raise the restraint bar, then use the lift and tilt controls (one at a time) to see if either function will operate.
 - a. If the liftarm can be raised or lowered, the lift solenoid is malfunctioning. **Figs. 8-24, 8-26**
 - b. If the attachment can be tilted, the tilt solenoid is malfunctioning. **Fig. 8-23**
4. Lower the restraint bar, BE SURE the parking brake on the instrument panel is in the OFF position.

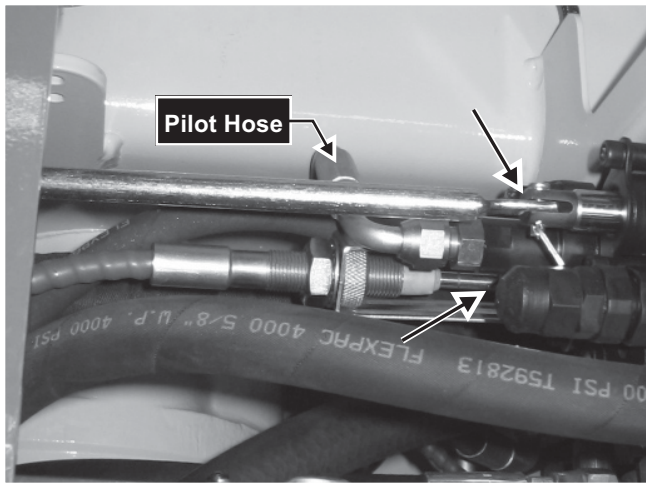

Fig. 8-71 View of Hand/Foot control valve. Disconnect the assemblies and two pilot control valve hoses attached to control valve spools.

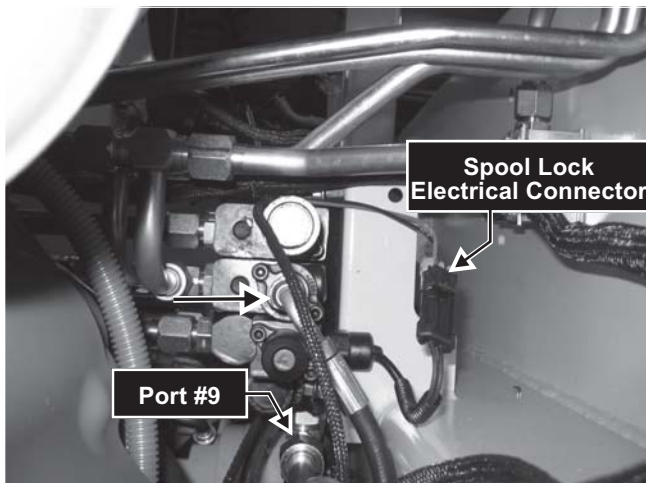

Fig. 8-72 Location of second pilot valve hose connected at the rear of the control valve.

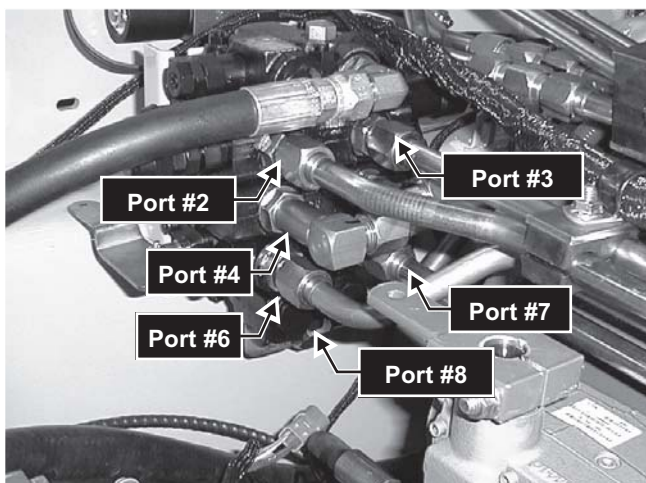

Fig. 8-73 Tubes on straight fittings on port #2 and port #3.

6. **Ports 4 and 5:** Disconnect the tilt tubes from 90° fittings on the control valve.
7. **Ports 6 and 7:** Disconnect the auxiliary tubes from straight fittings on the control valve.
8. **Port 8 (High-Flow only):** Disconnect the return tube and valve filter tube from the tee fitting on the side of the valve.
9. **Port 9:** Disconnect the valve inlet tube from the 90° fitting at bottom of the control valve.
10. Remove two capscrews and locknuts securing the control valve from the welded mounting bracket. **Fig. 8-75**
11. Lift the control valve out. Removal may require loosening the opposite ends of some of the disconnected tubes.

NOTE: Cap or plug ALL hydraulic hoses, tubes, fittings and control valve ports immediately after being disconnected to prevent fluid loss and contamination of the hydraulic system.

Installation Procedure

1. Secure the control valve to the welded bracket with two capscrews and locknuts. If straight fittings are not in the control valve, install them at this time. **Fig. 8-75**
2. **Port 9:** Connect the valve inlet tube to the 90° fitting at bottom of the control valve.
3. **Port 8 (High-Flow only):** Connect the return tube and valve filter tube to the tee fitting on the side of the valve.
4. **Ports 6 and 7:** Connect auxiliary tubes to straight fittings on the control valve.
5. **Ports 4 and 5:** Connect tilt tubes to 90° fittings on the control valve.
6. **Ports 2 and 3:** Connect lift tubes to straight fittings on control valve.
7. **Port 1:** Connect the gear pump hose to the 90° fitting.
8. Connect all items attached to the control valve spools. **On T-bar models** connect two control rods (lift and tilt) and auxiliary hydraulics control cable. **On Mechanical Auxiliary Hand/Foot models** connect one lift rod, auxiliary cable bonnet and two pilot valve hoses. **On Dual hand models** connect

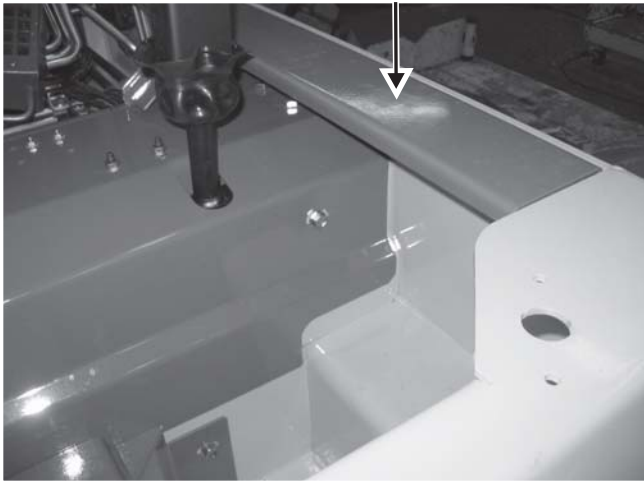

Fig. 8-98 Location of the left interior fender. Remove this fender to access the accumulator and its manifold.

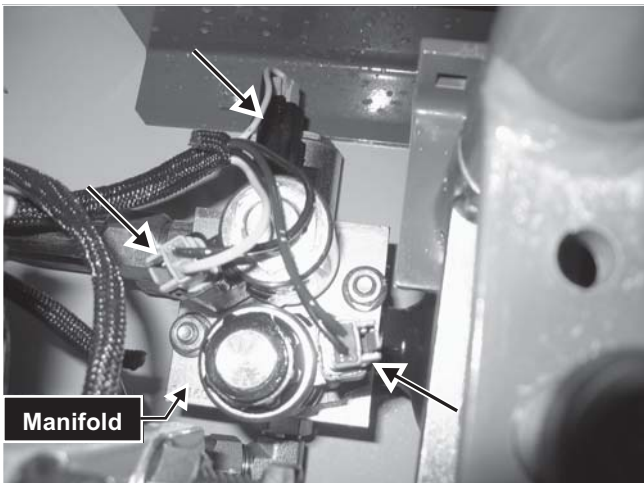

Fig. 8-99 Location of three electrical connectors on the accumulator manifold valve.

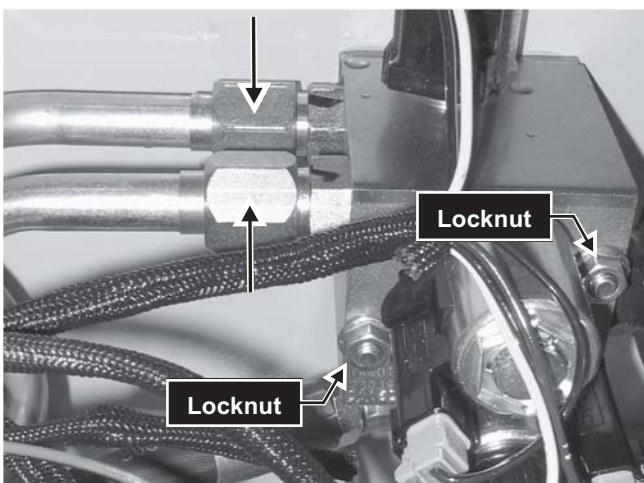

Fig. 8-100 Location of two hydraulic tubes attached to straight fittings on the accumulator manifold.

Hydraglide™ Ride Control Accumulator Removal and Installation

The Mustang 2066/76/86 skid-steer loaders offer as an option a ride control system. This system includes a hydraulically-driven accumulator that is electrically controlled in the right control handle and has its own solenoid.

Removal Procedure

⚠ WARNING

BEFORE beginning this service procedure, perform the following **SAFETY** procedures:

- Raise liftarm, engage liftarm support device.
- Shut off the engine.
- Relieve hydraulic system pressure.
- Roll ROPS back until lock engages.

(For detailed instructions, refer to the *Safety* chapter of this manual.)

1. Remove three machine screws securing the left interior fender (ROPS filler panel) to the side of the chassis. The machine screws can be accessed from outside the chassis. **Fig. 8-98**
2. Disconnect three electrical connectors on the manifold from the wire harness. **Fig. 8-99**
3. Remove two hydraulic tubes from straight fittings on the manifold. **Fig. 8-100**

NOTE: Cap or plug ALL hydraulic hoses, tubes, fittings and control valve ports immediately after being disconnected to prevent fluid loss and contamination of the hydraulic system.

4. Remove one hydraulic hose from 90° fitting at the bottom of the manifold. **Fig. 101**
5. Remove two locknuts on capscrews securing manifold (with accumulator attached) to chassis and remove both from the loader. **Fig. 100**
6. Place the manifold in a vise. Use a wrench and remove the accumulator from the manifold.

Ignition Switch Electrical Components

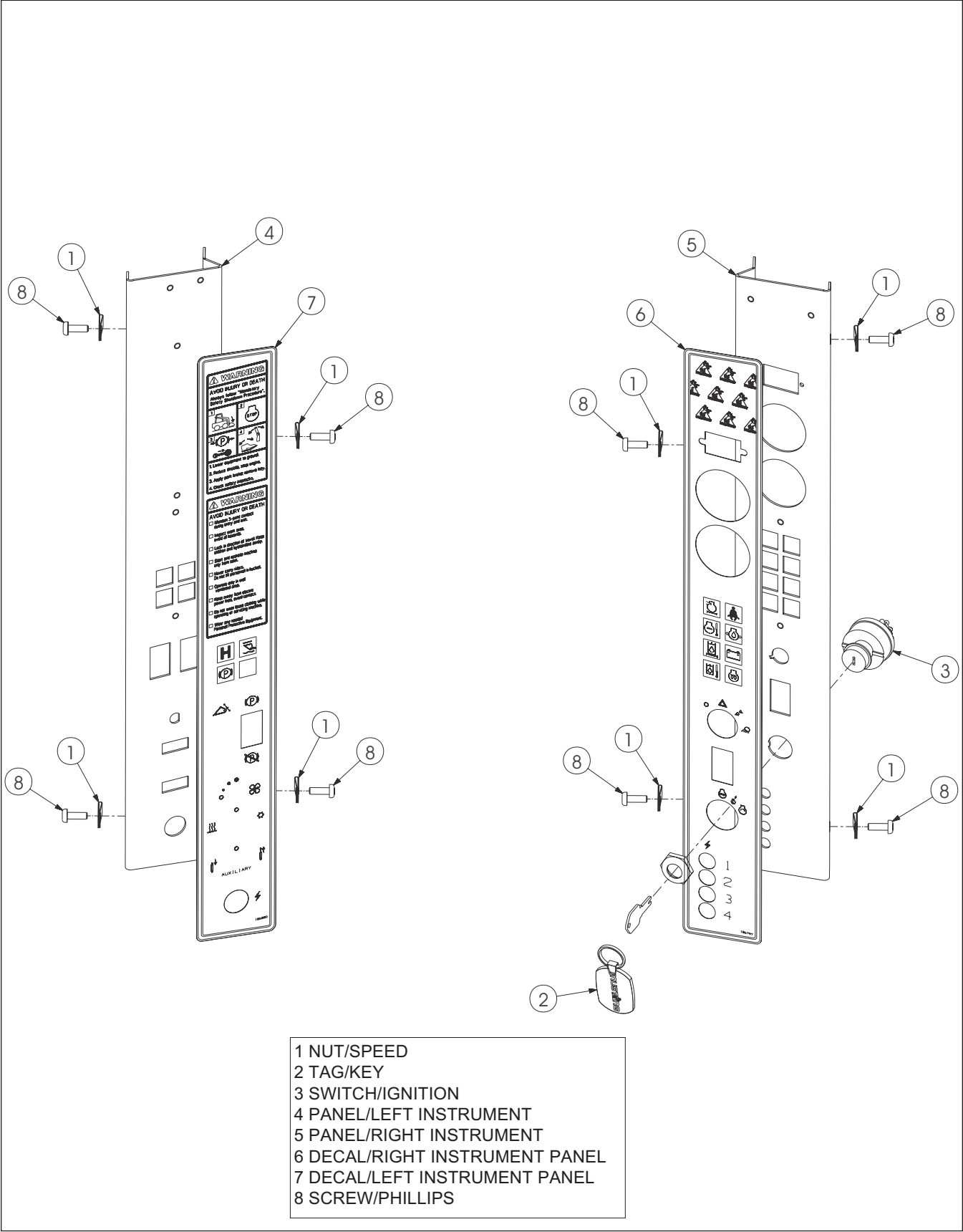

Fig. 9-5 Exploded view of the ignition switch electrical components.

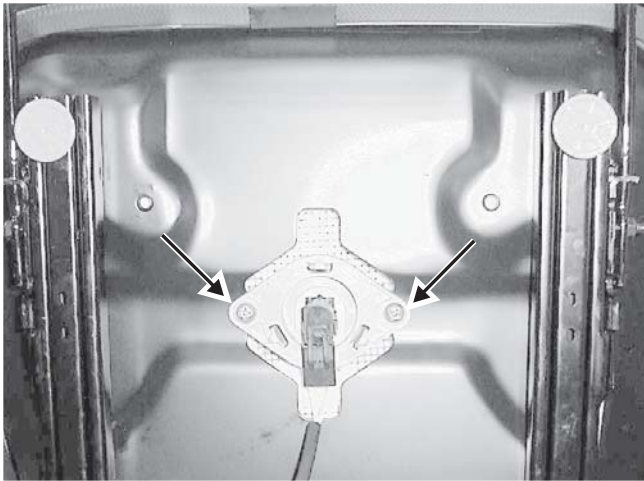

Fig. 9-21 Location of capscrews on standard seat.

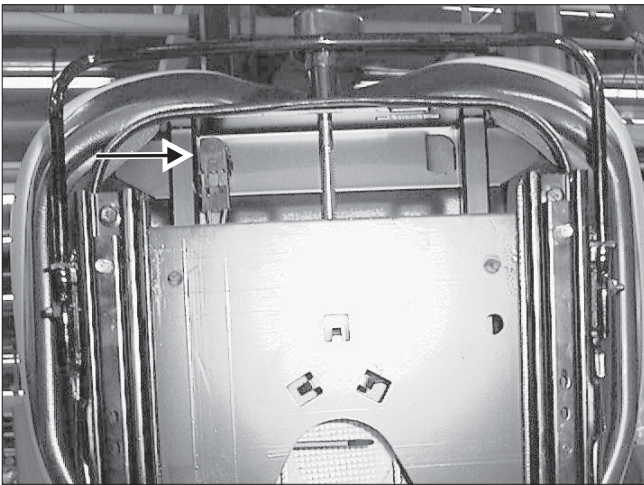

Fig. 9-22 Location of seat switch on a deluxe seat. There is a release tab on each side of the switch.

Seat Switch Removal and Installation

Removal Procedure

WARNING

BEFORE beginning this service procedure, perform the following SAFETY procedure:

- Shut off the engine.

(For detailed instructions, refer to the *Safety* chapter of this manual.)

1. Remove seat from loader per the procedure found in the *Mainframe* chapter. Turn the seat over.
2. Seat switch removal: **Figs. 9-21, 9-22**
 - a. **Standard Seat:** Remove two capscrews and nuts securing seat switch to seat. Press three tabs to separate dome from base. Press two tabs to remove switch from base.
 - b. **Deluxe Seat:** Press two tabs, one on each side of seat switch. Push switch through bracket and pull out of seat.

WARNING

DO NOT attempt to operate the loader without the seat switch installed.

Installation Procedure - Follow all warnings first, then reverse the removal steps.*

* Install seat on loader as per procedure in *Mainframe* chapter.

Heater Schematic

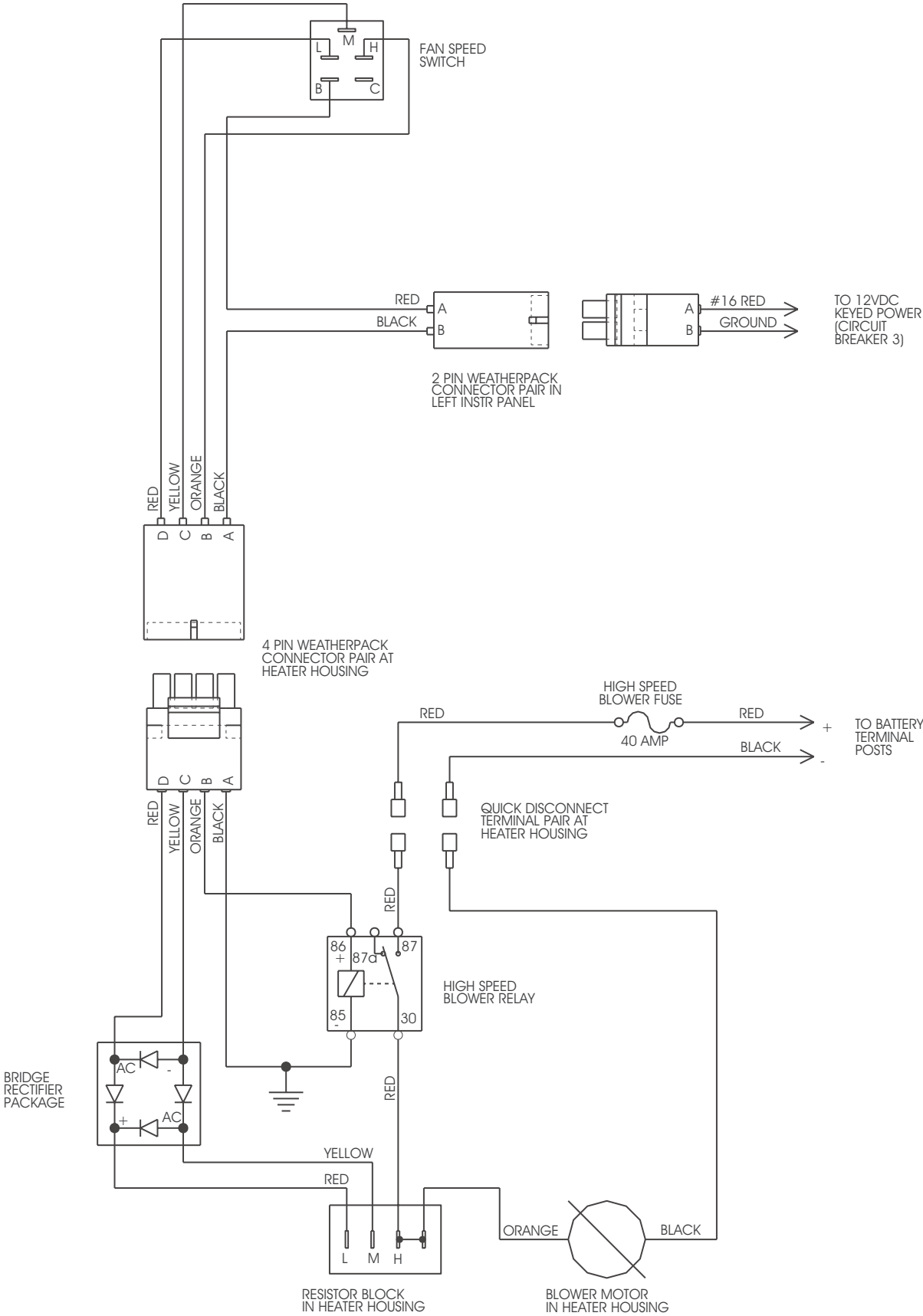

ELECTRICAL

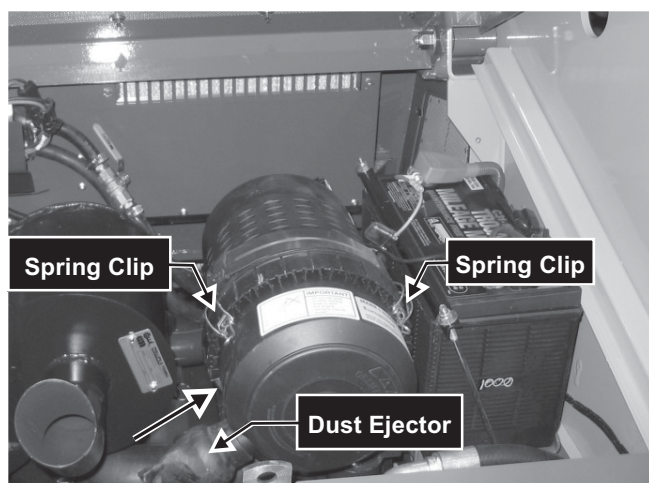

Fig. 10-12 Pull cover off the air cleaner assembly.

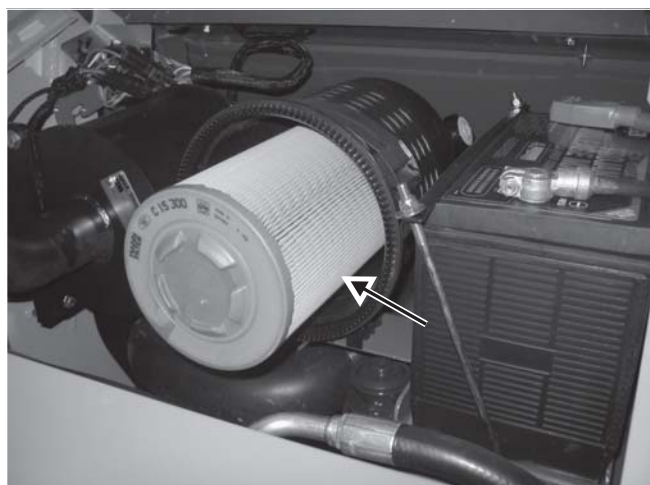

Fig. 10-13 View of the primary filter element.



Fig. 10-14 View of the safety filter element inside of the primary filter element.

Air Filter Element Removal and Installation

Service the air filter element when the restriction gauge shows in the red zone. The red zone indicates a clogged air filter. If the gauge shows red with the engine stopped, replace the air filter element. After fitting a clean element, push gauge reset button.

WARNING

BEFORE beginning this service procedure, perform the following **SAFETY** procedure:

- Shut off the engine.

(For detailed instructions, refer to the *Safety* chapter of this manual.)

Removal Procedure

1. Open engine access cover and rear grille.
2. Release three spring clips securing cover and remove cover. Clean out dirt build up in cover assembly. **Fig. 10-12**
3. Pull primary and safety air filter from housing. **Figs. 10-13, 10-14**
4. Replace both air filter elements, if needed. (See *Service* chapter of the Operator's Manual.)
5. Check condition of dust ejector. **Fig. 10-12**

Installation Procedure - Follow all warnings first, then reverse the removal steps.*

* Clean mating plastic body for radial seal surfaces. **Fig. 10-15**

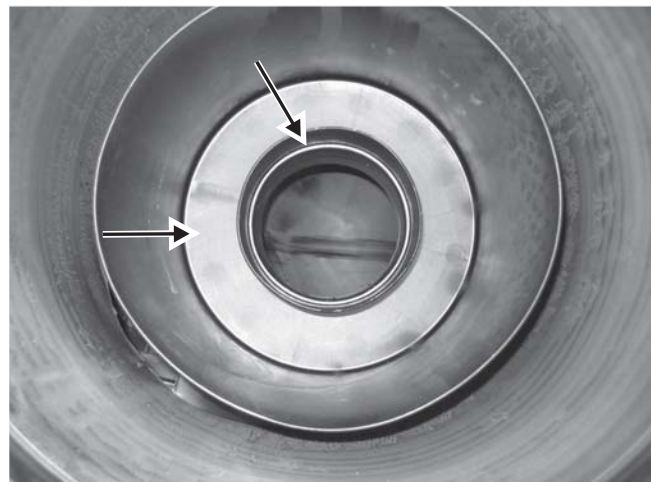

Fig. 10-15 View of the radial seal surfaces inside the air canister. Clean mating surfaces for good seals.

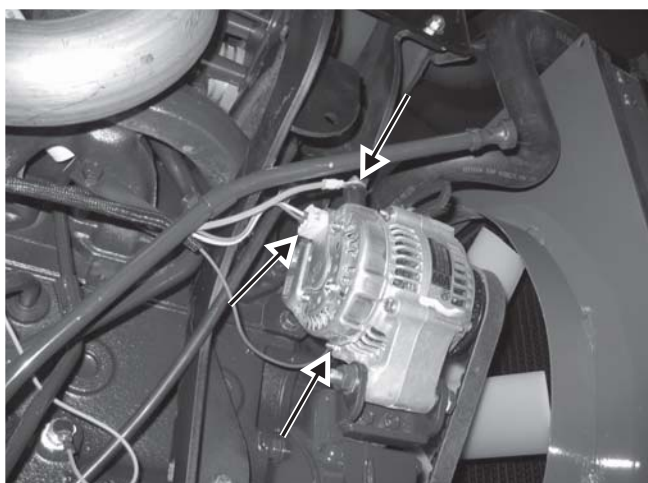

Fig. 10-43 Some of the disconnect locations on the engine prior to removing the engine from the skid-steer loader.

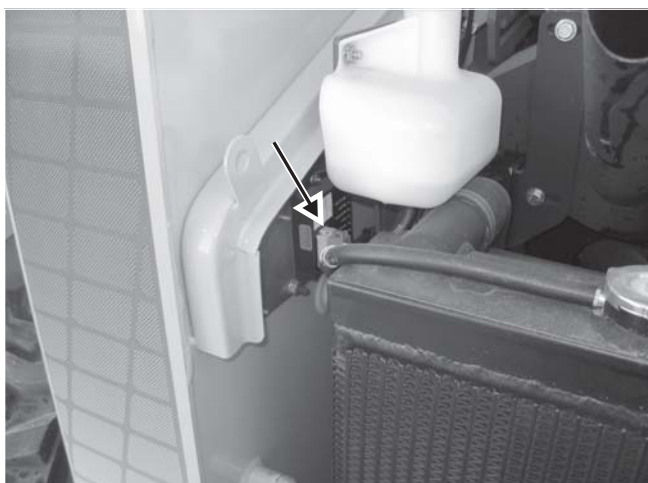

Fig. 10-44 One of two electrical panels on the skid-steer loader. Disconnect all electrical connections prior to removing the engine.

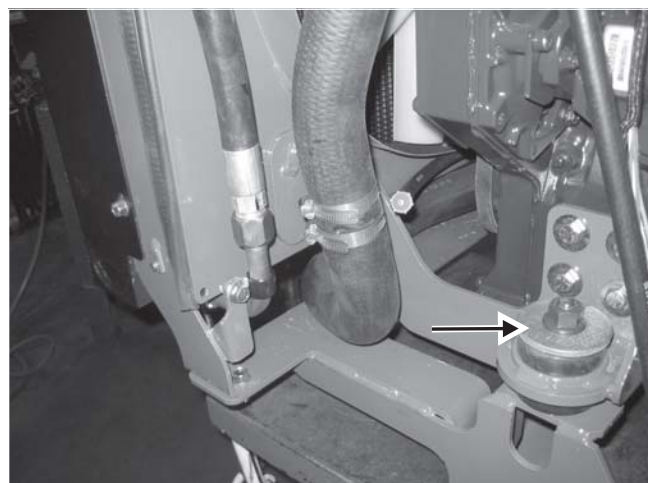

Fig. 10-46 One of four engine mounts to disconnect prior to removing the engine.

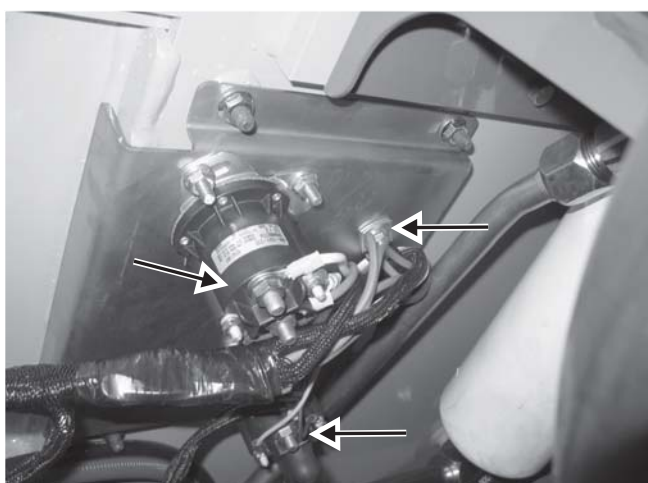

Fig. 10-45 The other electrical panel on the skid-steer loader. Disconnect all electrical connections prior to removing the engine.

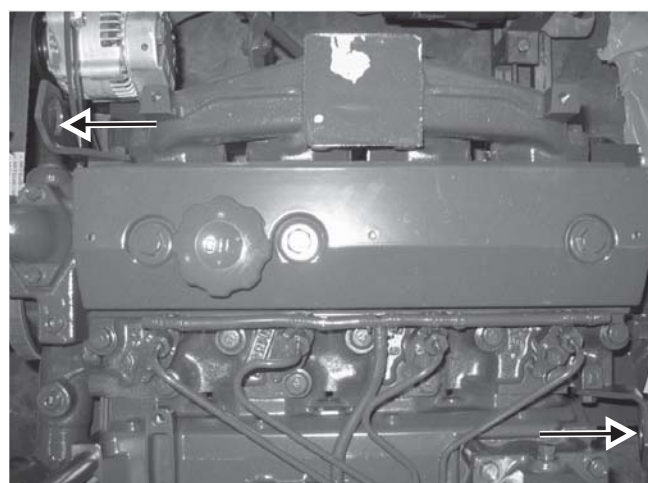

Fig. 10-47 Location of lift hooks on engine (shown without the exhaust installed).

Installation Procedure - Follow all warnings first, then reverse the removal steps.*

* If the diesel fuel was drained, add fuel, then bleed the fuel system. Also check engine oil and hydraulic oil levels prior to starting the skid-steer loader.

* Safely check for hydraulic fluid leaks observing the correct procedure in doing so (refer to *Hydraulic System* chapter). Perform the neutral centering adjustment procedure found in the *Controls* chapter.

CLICK HERE TO **DOWNLOAD** THE COMPLETE MANUAL

- Thank you very much for reading the preview of the manual.
- You can download the complete manual from: www.heydownloads.com by clicking the link below



- Please note: If there is no response to CLICKING the link, please download this PDF first and then click on it.

CLICK HERE TO **DOWNLOAD** THE COMPLETE MANUAL