

Service Manual

LASER TALON & Eclipse

Volume-1
Engine, Chassis
& Body

FOREWORD

This Service Manual has been prepared with the latest service information available at the time of publication. It is subdivided into various group categories and each section contains diagnosis, disassembly, repair, and installation procedures along with complete specifications and tightening references. Use of this manual will aid in properly performing any servicing necessary to maintain or restore the high levels of performance and reliability designed into these outstanding vehicles.



**CHRYSLER
CORPORATION**

Chrysler Corporation reserves the right to make changes in design or to make additions to or improvements in its products without imposing any obligations upon itself to install them on its products previously manufactured.

Introduction and Master Troubleshooting	0
Lubrication and Maintenance	2
Front Suspension	3
Rear Axle	5
Brakes— Service Parking	6
Clutch	7
Cooling	9
Engine	11
Intake and Exhaust	14
Fuel System	16
Propeller Shaft	17
R e a r Suspension.....	19
Steering- Manual Power	21
Transaxle— Manual Automatic	22
Wheels and Tires	23
Body	24
Heater & Air Conditioning	25
Emission Control Systems	25

NOTE: For Electrical, refer to Volume-2 "Electrical".

CLICK HERE TO **DOWNLOAD** THE COMPLETE MANUAL

- Thank you very much for reading the preview of the manual.
- You can download the complete manual from: www.heydownloads.com by clicking the link below



- Please note: If there is no response to CLICKING the link, please download this PDF first and then click on it.

CLICK HERE TO **DOWNLOAD** THE COMPLETE MANUAL

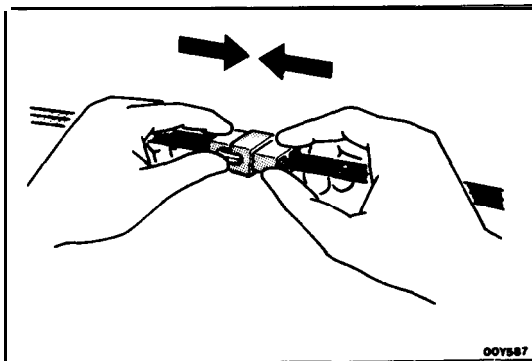

5. Connect connectors which have catches by inserting the connectors until they snap.

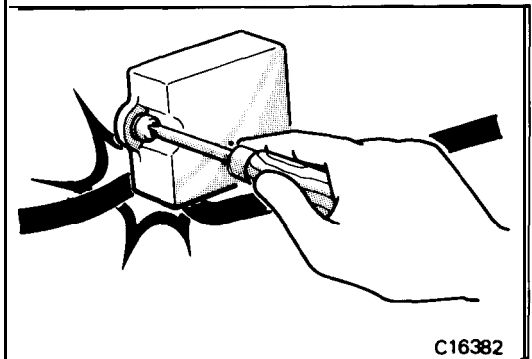

ELECTRICAL COMPONENTS

1. When installing any of the vehicle parts, be careful not to pinch or damage any of the wiring harnesses.

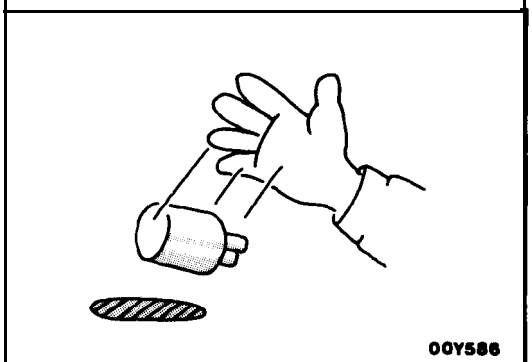

2. Sensors, relays, etc., are sensitive to strong impacts. Handle them with care so that they are not dropped or mishandled.

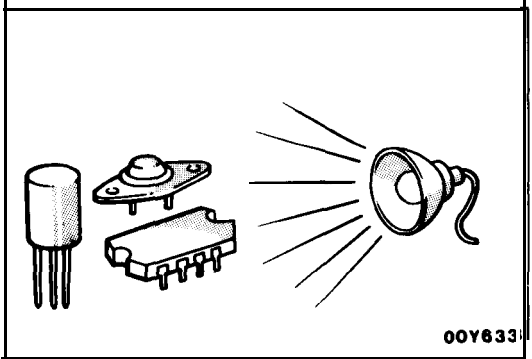

3. The electronic parts used for relays, etc., are sensitive to heat. If any service which causes a temperature of 80°C (176°F) or more is performed, remove the part or parts in question before carrying out the service.

FUSES AND FUSIBLE LINKS

1. If a blown-out fuse is to be replaced, be sure to use only a fuse of the specified capacity. If a fuse of a capacity larger than that specified is used, parts may be damaged and the circuit may not be protected adequately.

Caution

1. If a fuse is blown-out, be sure to eliminate the cause of the problem before installing a new fuse.
2. Check the condition of fuse holders. If rust or dirt is found, clean metal parts with a **fine-grained** sandpaper until proper metal-to-metal contact is **made**. Poor contact of any fuse holder will **often lead to voltage drop or heating in the circuit and could result in improper circuit operation.**

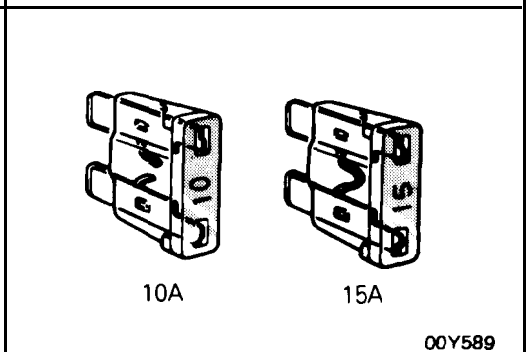

POOR FUEL MILEAGE

Symptom	Probable cause	Reference page or remedy"
Poor fuel mileage	Fuel leak	Repair as necessary.
	Air cleaner clogged.	—
	Ignition system problems	8-169
	Fuel injection system problems.	—
	Compression too low.	9-23
	Tires improperly inflated.	22-3
	Clutch slips.	6-4
	Brakes drag.	5-7

NOISE

Symptom	Probable cause	Reference page or remedy
Noise	Loose bolts and nuts.	Retighten as necessary .
	Engine noise	9-23

HARD STEERING

Symptom	Probable cause	Reference page or remedy
Hard steering	Loose power steering oil pump belt	19-12
	Low fluid level	Replenish
	Air in power steering system	19-13
	Low tire pressure	22-3
	Excessive turning resistance of lower arm ball joint	2-35
	Excessively tightened of steering gear box rack support cover	19-23, 30
	Improper front wheel alignment	2-8
	Excessive turning resistance of tie-rod ball joint	19-8, 10
	Sticky flow control valve	19-41
Bent rack in steering gear box	19-23, 30	

POOR RETURN OF STEERING WHEEL TO CENTER

Symptom	Probable cause	Reference page
Poor return of steering wheel to center	Improper front wheel alignment	2-8
	Improper tire pressure	22-3
	Excessive tightened rack support cover	19-23, 30
	Damage d front wheel bearing	2-12

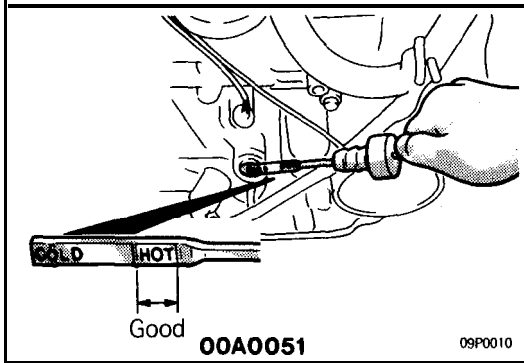

- (9) Supply 4 liters (8.5 pints) of specified ATF into case through dipstick hole. [Total quantity of ATF required is 6.1 liters (12.9 pints).

Actually however, approx. 4.5 liters (9.5 pints) of fluid can be replaced because rest of fluid remains in torque converter.]

Specified fluid: MOPAR ATF PLUS (Automatic Transmission Fluid Type 7176) or Dia ATF SP or Equivalent

- (10) Start engine and allow to idle for at least two minutes. Then, with parking brake on, move selector lever momentarily to each position, ending in "N" Neutral position.
- (11) Add sufficient ATF to bring fluid level to lower mark. Recheck fluid level after transaxle is at normal operating temperature. Fluid level should be between upper and lower marks of "HOT" range. Insert dipstick fully to prevent dirt from entering transaxle.

11. ENGINE COOLANT (Change)

N00SBEAc

Check the cooling system parts, such as radiator, heater, and oil cooler hoses, thermostat and connections for leakage and damage.

CHANGE COOLANT

1. Remove the radiator cap.
2. Loosen the drain plug to drain the coolant.
3. Drain the coolant from the reserve tank.
4. After draining the coolant, tighten the drain plug securely.
5. Supply the coolant into the radiator until it is filled up to its filler neck.
6. Supply the coolant into the reserve tank.
7. After warming the engine until the thermostat opens, remove the radiator cap and check the coolant level.
8. Supply the coolant into the radiator until it is filled up to its filler neck, and install the radiator cap securely.
9. Fill the reserve tank with coolant up to the "FULL" line.

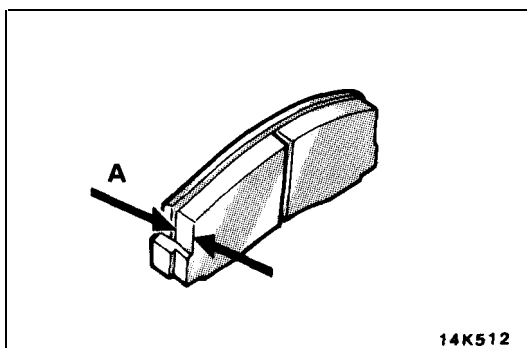

12. DISC BRAKE PADS (Inspect for wear)

N00SBFAa

Check for fluid contamination and wear. Replace complete set of pads if defective.

Caution

The pads for the right and left wheels should be replaced at the same time. Never "split" or intermix brake pad sets.

All four pads must be replaced as a complete set.

Thickness of lining (A)

Limit : 2.0 mm (.08 in.)

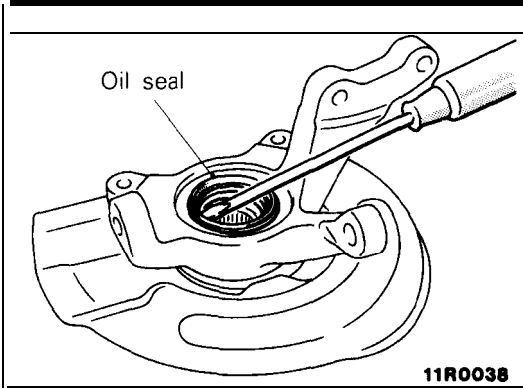

11R0038

2. REMOVAL OF OIL SEAL (DRIVE SHAFT SIDE)

Remove the oil seal (drive shaft side) from the knuckle.

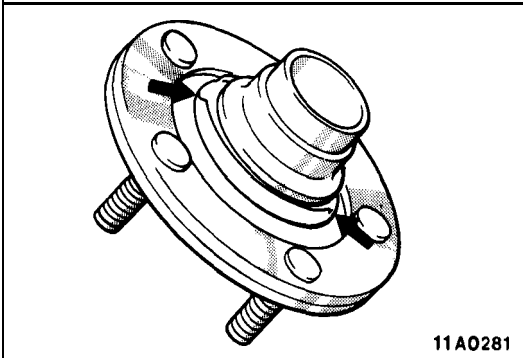

11A0281

5. REMOVAL OF WHEEL BEARING

(1) Crush the oil seal in two places so that the tabs of the special tool will be caught on the wheel bearing inner race.

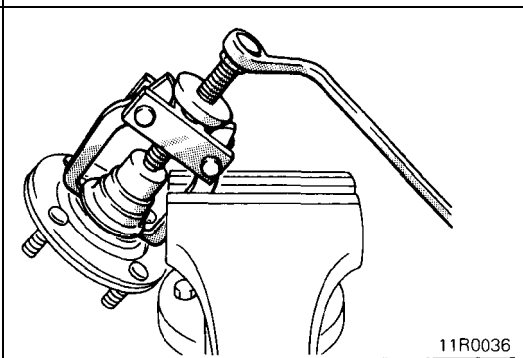

11R0036

(2) Remove the wheel bearing inner race from the front hub by using the suitable puller.

NOTE

Be careful that the front hub will not fall down at the wheel bearing inner race (outer side) removed from the hub.

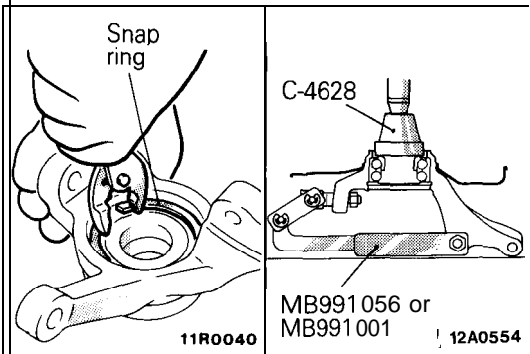

11R0040

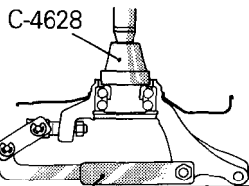

MB991056 or MB991001 12A0554

(3) Remove the snap ring from the knuckle.

(4) Remove the bearing by using the special tools.

Caution

Removal is easier if the outer side inner race removed from the hub is placed on the bearing and the wheel bearing is then removed.

INSPECTION

N02IGABa

- Check the front hub and brake disc mounting surfaces for galling and contamination.
- Check the knuckle inner surface for galling and cracks.
- Check for defective bearing.

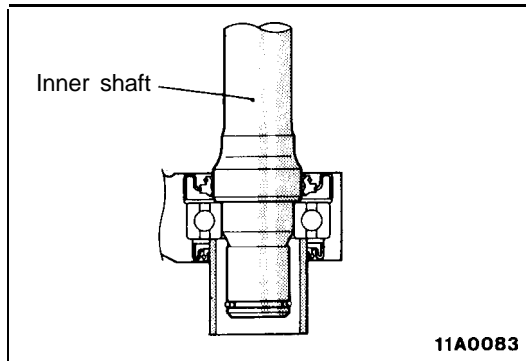

6. INSTALLATION OF INNER SHAFT

Use a pipe to hold the inner race of the center bearing and force the inner shaft into place.

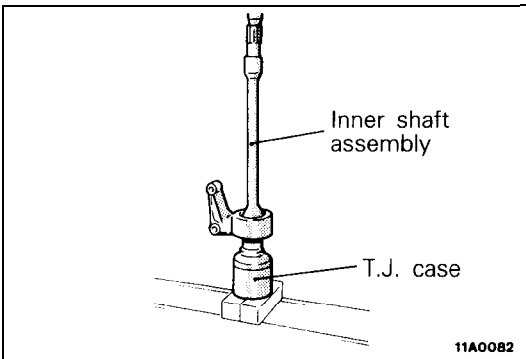

3. INSTALLATION OF T.J. CASE AND INNER SHAFT ASSEMBLY

- (1) Apply multipurpose grease to the inner shaft spline, then press fit it into the T.J. case.

**Grease: MOPAR Multi-mileage Lubricant
Part No. 2525035 or equivalent**

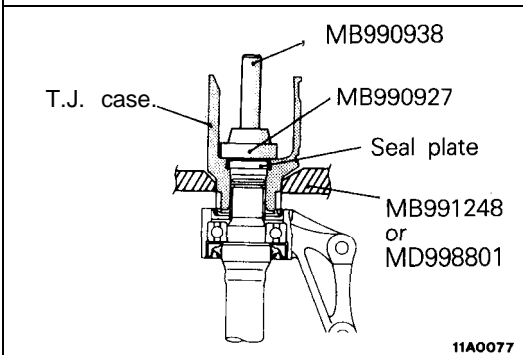

- (2) Using the special tools, press the seal plate into the T.J. case.

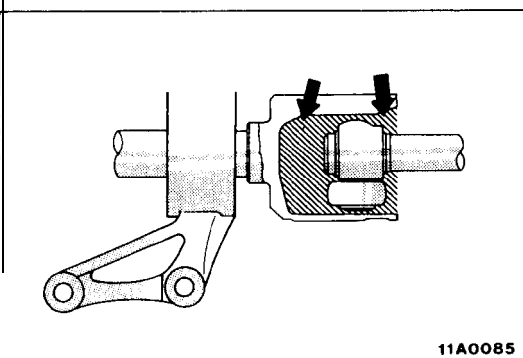

- (3) Fill the specified grease furnished in the repair kit to the T.J. case.

Specified grease: Repair kit grease 105 g (3.7 oz.)

NOTE

The grease in the repair kit should be divided in half for use, respectively, at the joint and inside the boot.

Caution

The drive shaft joint use special grease. Do not add another type of grease.

2. INSTALLATION OF BOOT BAND (SMALL)/ 1. T.J. BOOT BAND

Set the T.J. boot bands at the specified distance in order to adjust the amount of air inside the T.J. boot, and then tighten the T.J. boot band securely.

Standard value: 85 ± 3 mm (3.35 ± .12 in.)

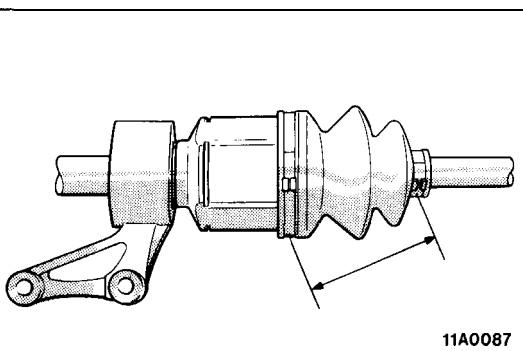

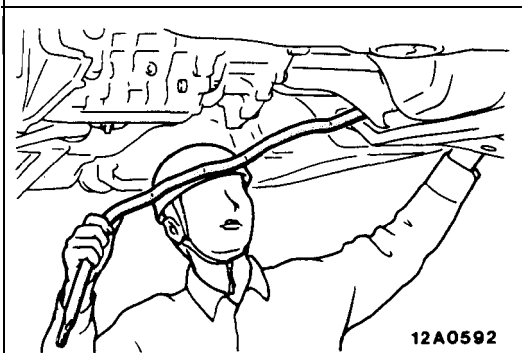
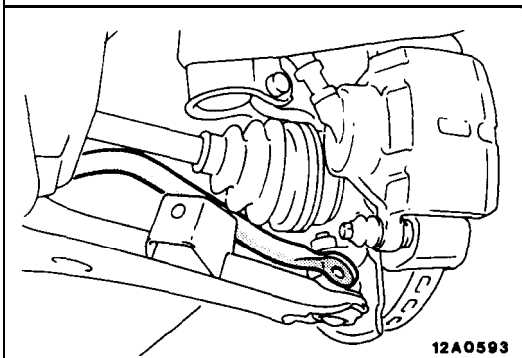
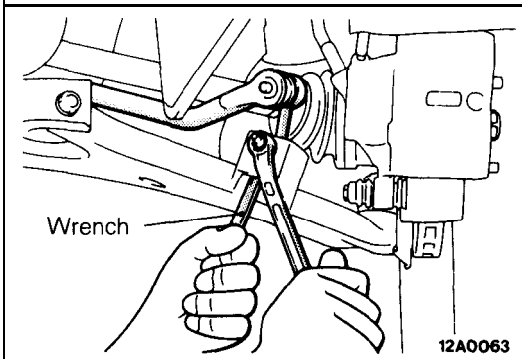
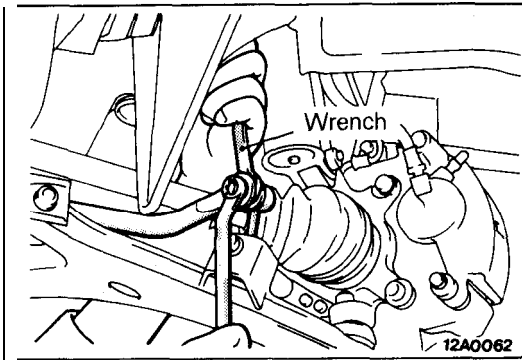
**SERVICE POINTS OF REMOVAL**

N02TBAG

4. REMOVAL OF STABILIZER LINK MOUNTING NUTS

Using a wrench or similar tool to secure the ball studs at both ends of the stabilizer link, remove the mounting nuts,

9. REMOVAL OF STABILIZER BAR

- (1) Disconnect the coupling of the knuckle and lower arm at the right side.
- (2) Pull out the left side stabilizer bar edge, pulling it out between the drive shaft and lower arm.

- (3) Pull out the right side stabilizer bar edge, pulling it out from below the lower arm.

INSPECTION

N02CAH

Refer to P.2-40.

BALL JOINT DUST COVER REPLACEMENT

N02TEAD

Refer to P.2-40.

SERVICE POINTS OF INSTALLATION





N02TDAN

**7. INSTALLATION OF STABILIZER BAR BRACKET/
4. STABILIZER LINK INSTALLATION NUT**

Refer to P.2-41.

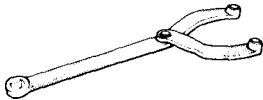
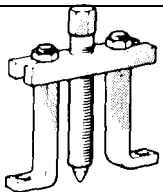
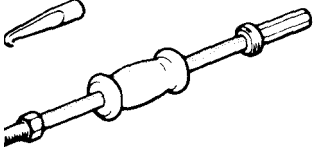
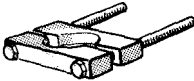
SPECIAL TOOLS

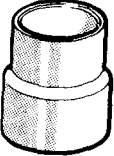
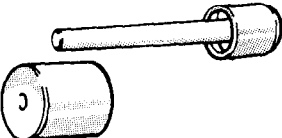
N03DA--

Tool	Number	Name	Use
	MB990767	End yoke holder	Measurement of rotation torque of the limiter slip differential Stop axle shaft turning
	CT-I 003	Axle shaft puller	Press-fitting the drive pinion rear bearing outer race
	C-673	Sliding hammer set	Removal of the axle shaft
	MB990560	Bearing remover	Removal of the axle shaft dust cover, outer bearing and rear rotor Press-in the outer wheel bearing and rear rotor
	MB991115	Oil seal installer	Press-fitting of drive shaft oil seal
	MB990799	Ball joint dust cover installer	Press-fitting the axle shaft dust cover
	MB990641	Lower arm bushing installer and remover A	Driving-out and press-fitting of differential support member bushing
	MB990810	Side bearing puller	Removal of the side bearing inner race
	MB990811	Side bearing cup	

DIFFERENTIAL CARRIER

REMOVAL AND INSTALLATION

N031A--

Pre-removal Operation

- @ Drainage of Differential Gear Oil (Refer to P.3-8.)
- * Removal of Center Exhaust Pipe (Refer to GROUP 1 I-Exhaust Pipe and Main Muffler.)

Post-installation Operation

- Installation of Center Exhaust Pipe (Refer to GROUP 11-Exhaust Pipe and Main Muffler.)
- Filling Differential Gear Oil (Refer to P.3-8.)

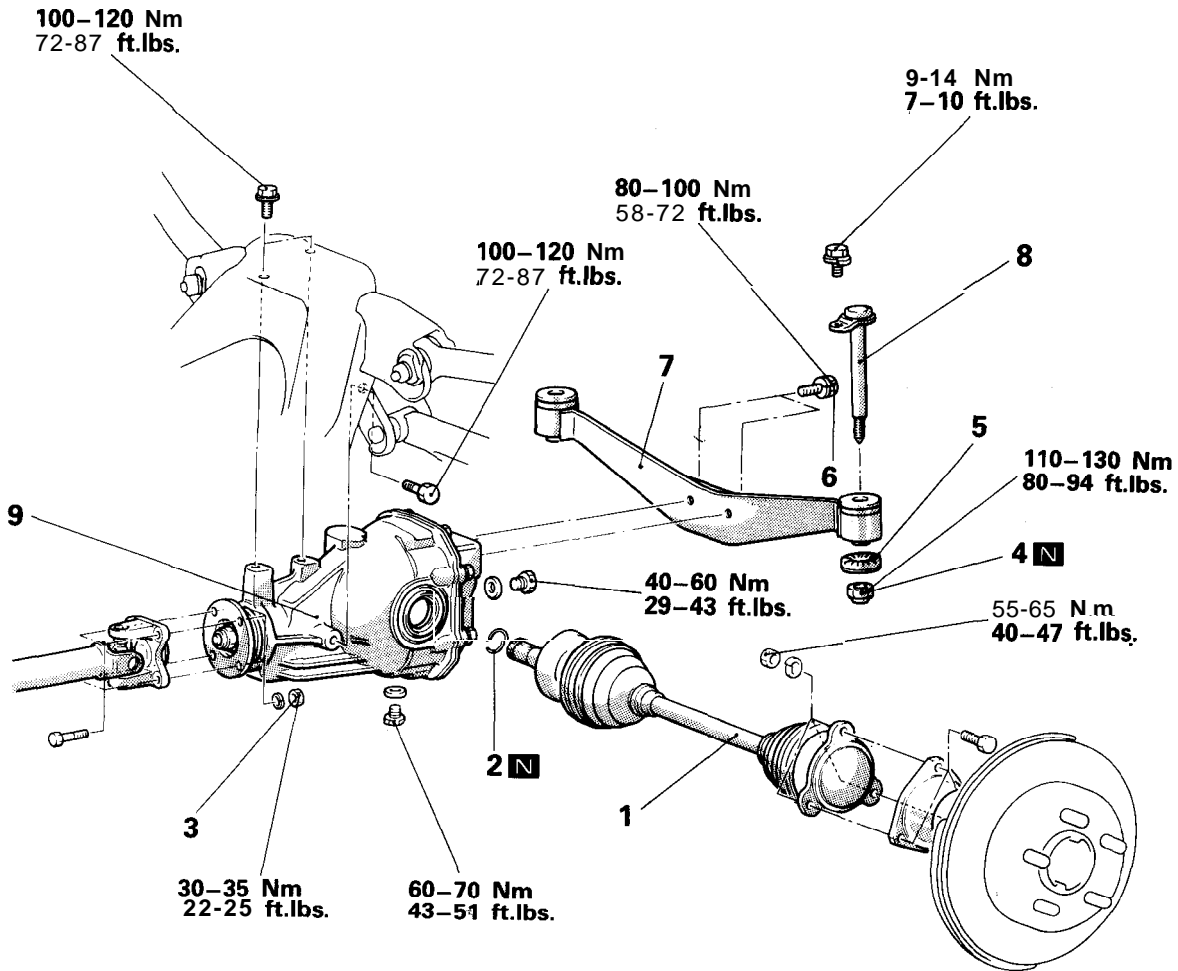

Removal steps

- ◄◄ 1. Drive shaft
- ◄◄◄ 2. Circlip
- ◄◄◄◄ 3. Propeller shaft connection
- 4. Differential support member installation nut
- 5. Stopper (lower)
- 6. Differential support member installation bolts
- 7. Differential support member
- 8. Differential support member installation bolts
- 9. Differential carrier

11A0358

NOTE

- (1) Reverse the removal procedures to reinstall
- (2) ◄◄◄: Refer to "Service Points of Removal".
- (2) ◄◄◄◄: Refer to "Service Points of Installation".
- (3) [N]: Non-reusable parts.

DIFFERENTIAL CARRIER (LIMITED SLIP DIFFERENTIAL)**DISASSEMBLY AND REASSEMBLY**

N031K--

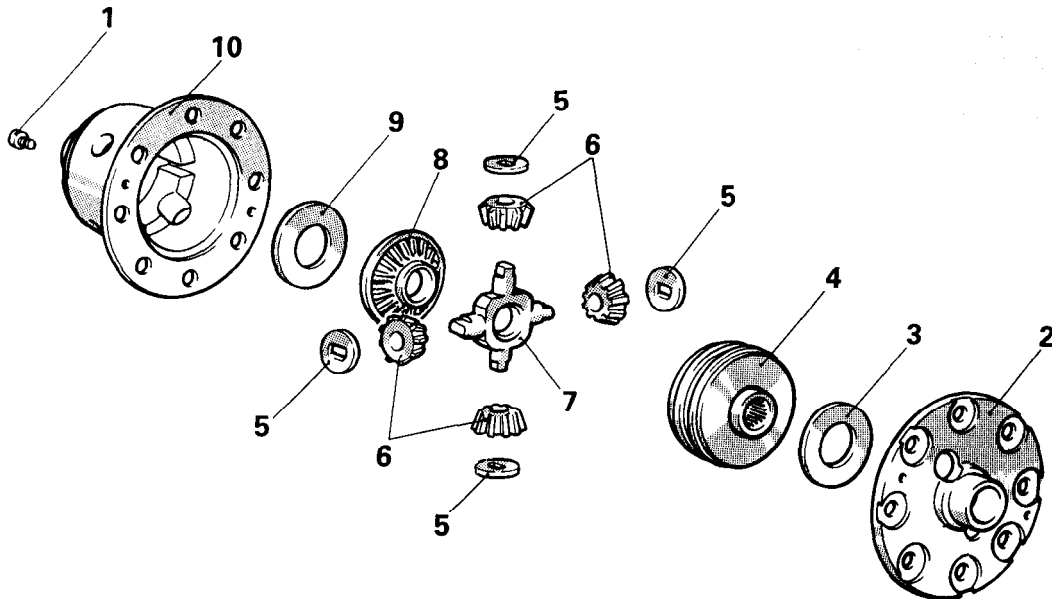
**Disassembly steps**

- 1. Screw
- + 2. Differential case A
- ◄◄◄◄ 3. Thrust washer (L.H.)
- 4. Viscous unit
- ◆◆ 5. Pinion mate washer
- ◆◆ 6. Differential pinion mate
- 7. Differential pinion shaft
- 8. Differential side gear (R.H.)
- ◄◄ 9. Thrust washer (R.H.)
- + 10. Differential case B

11P0127

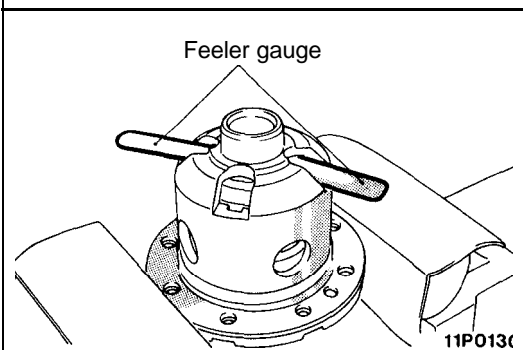

11P0131

INSPECTION BEFORE DISASSEMBLY

N031EBA

1. CHECKING THE DIFFERENTIAL GEAR BACKLASH

- (1) Secure the differential case assembly in a vise so that the differential side gear (right) is facing upward.

Caution

When securing the vise, be sure not to hold the differential case assembly too tightly.

- (2) Insert a 0.03 mm (.0012 in.) feeler gauge at two places (diagonally) between differential case B and the thrust washer (right).

Caution

Do not insert a feeler gauge in the oil groove of differential case B.

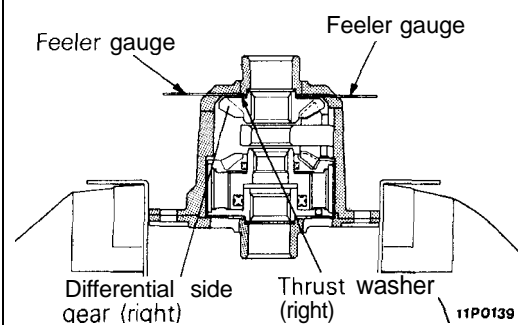

11P0139

No.	Trouble condition	Major causes	Remedy
4	<p>After the ignition key is turned to the "ON" position, it blinks once and then illuminates when it is turned to the "START" position. When the key is returned to the "ON" position, the light blinks again. (Blinking with the ignition key in the "ON" position is synchronized with operation noise of the valve relay.)</p> <div style="display: flex; align-items: center;"> <div style="margin-right: 10px;"> <p>ABS warning light</p> <p>ON</p> <p>OFF</p> </div> </div> <p style="margin-top: 10px;">Ignition key</p> <p style="margin-left: 20px;">ON</p> <p style="margin-left: 20px;">ACC, LOCK</p> <p style="text-align: right; font-size: small;">14A0593</p>	<ul style="list-style-type: none"> Break in harness for ECU warning light drive circuit Malfunction of ECU 	<p>Check, using flow chart D. (Refer to P.5-18.)</p>

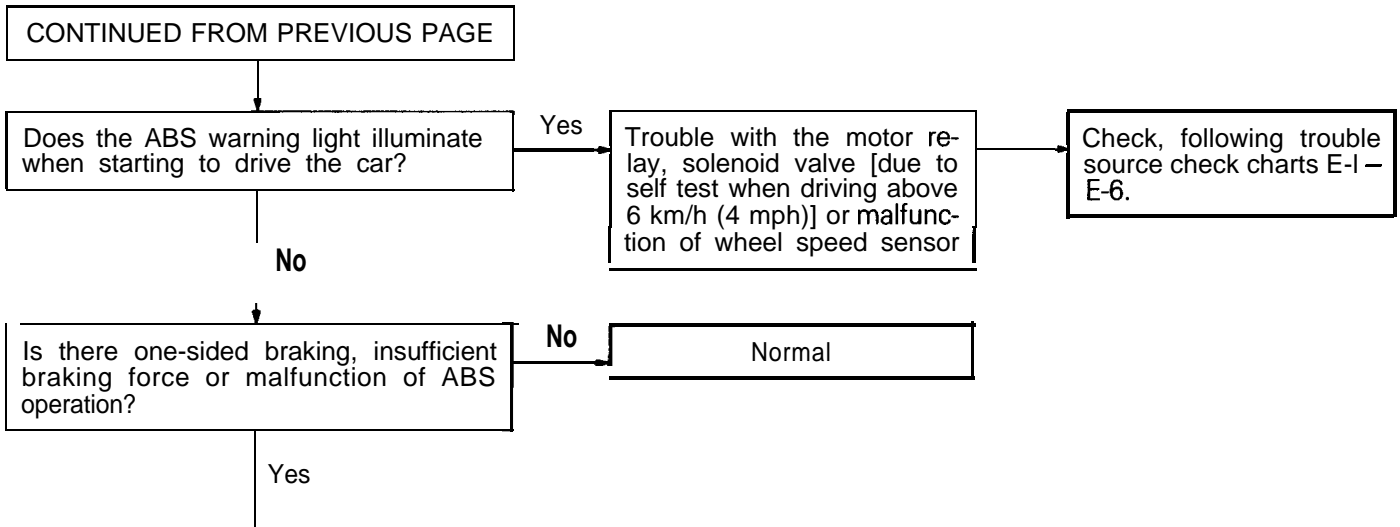

Trouble condition	Major causes	Remedy
One-sided braking Insufficient braking force	<ul style="list-style-type: none"> Mechanical lock of HU solenoid valve Hydraulic line in HU is clogged. 	<p>Check HU operation and, if necessary, replace HU. If HU is normal, check structural parts for normal braking. (Refer to P.5-7.)</p>
Decline in ABS function (Wheels easily lock when there is sudden braking.)	<ul style="list-style-type: none"> Malfunction in HU solenoid valve operation Hydraulic line in HU is clogged. 	
ABS sometimes functions even when there is no sudden braking. (ABS operation vibration is transmitted.)	<ul style="list-style-type: none"> Insufficient wheel speed sensor output voltage (sensor malfunction, too large a gap between sensor rotor, missing rotor teeth or temporarily broken wire in sensor harness) Malfunction of ABS ECU 	<p>Check wheel speed sensor (Refer to P.5-82.) and, if necessary, replace sensor, adjust gap or replace rotor. If tests indicate that there are no mechanical or electrical failures, replace the ECU.</p>

No.	Trouble condition	Major causes	Remedy
4	<p>After the ignition key is turned to the "ON" position, it blinks once and then illuminates when it is turned to the "START" position. When the key is returned to the "ON" position, the light blinks again. (Blinking with the ignition key in the "ON" position is synchronized with operation noise of the valve relay.)</p> <p>14A0593</p>	<ul style="list-style-type: none"> • Break in harness for ECU warning light drive circuit • Malfunction of ECU 	<p>Check, using flow chart D. (Refer to P.5-33.)</p>

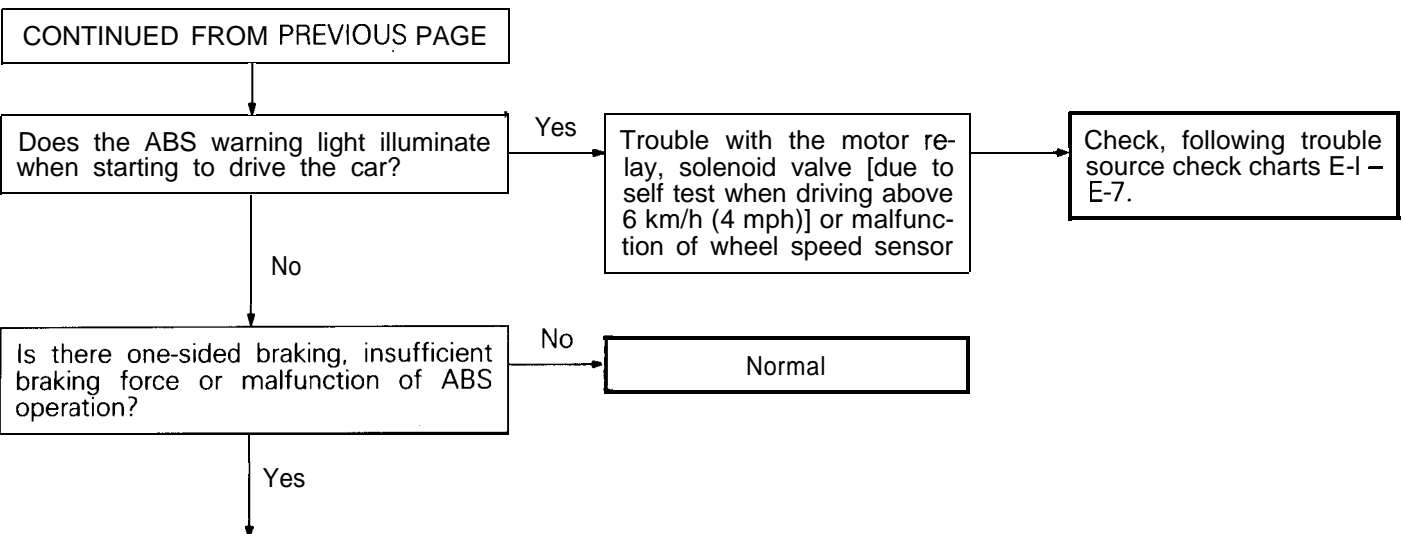

Trouble condition	Major causes	Remedy
One-sided braking Insufficient braking force	<ul style="list-style-type: none"> • Mechanical lock of HU solenoid valve • Hydraulic line in HU is clogged. 	<p>Check HU operation and, if necessary, replace HU.</p>
Decline in ABS function (Wheels easily lock when there is sudden braking.)	<ul style="list-style-type: none"> • Malfunction in HU solenoid valve operation • Hydraulic line in HU is clogged. 	<p>If HU is normal, check structural parts for normal braking. (Refer to P.5-2.)</p>
ABS sometimes functions even when there is no sudden braking. (ABS operation vibration is transmitted.)	<ul style="list-style-type: none"> • Insufficient wheel speed sensor output voltage (sensor malfunction, too large a gap between sensor rotor, missing rotor teeth or temporarily broken wire in sensor harness) • Malfunction of ABS ECU 	<p>Check wheel speed sensor too (Refer to P.5-82.) and, if necessary, replace sensor, adjust gap or replace rotor.</p> <p>If tests indicate that there are no mechanical or electrical failures, replace the ECU.</p>

SERVICE ADJUSTMENT PROCEDURES**BRAKE PEDAL INSPECTION AND ADJUSTMENT**

N05FAAH

1. Measure the brake pedal height as illustrated. If the brake pedal height is not within the standard value, adjust as follows.

Standard value (A): 176–181 mm (6.9–7.1 in.)

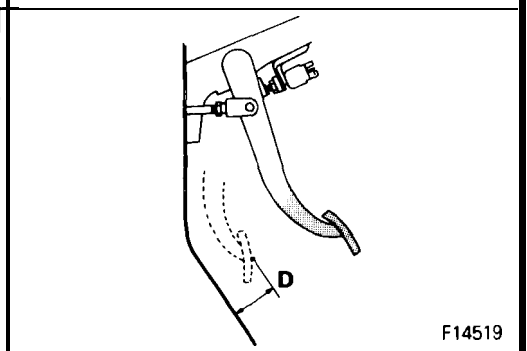
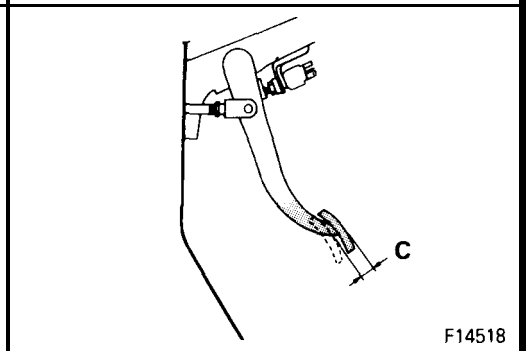
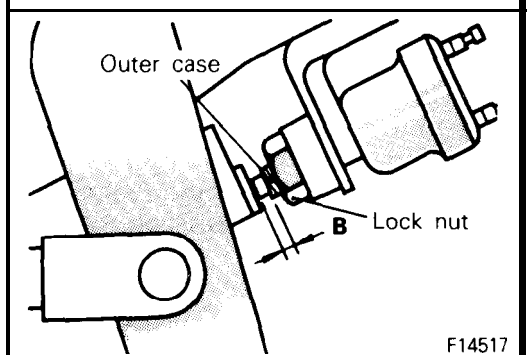
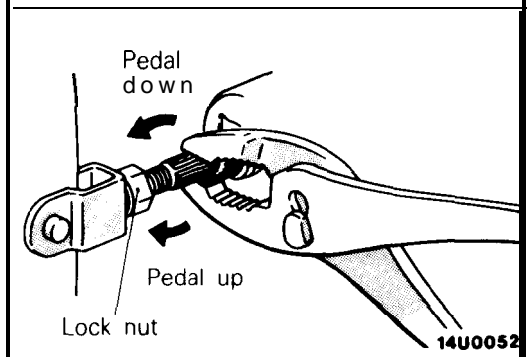
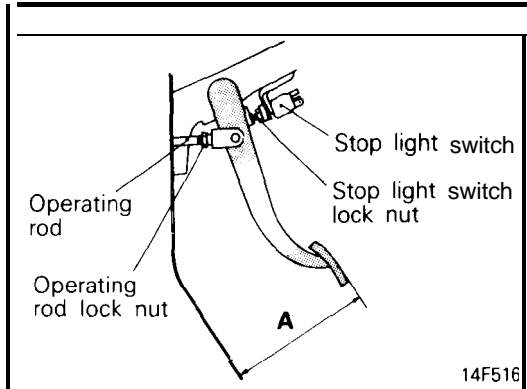

- (1) Disconnect the stop light switch connector, loosen the lock nut, and move the stop light switch to a position where it does not contact the brake pedal arm.
- (2) Adjust the brake pedal height by turning the operating rod with pliers (with the operating rod lock nut loosened), until the correct brake pedal height is obtained.
- (3) After screwing in the stop light switch until it contacts the brake pedal stopper (just before the brake pedal is caused to move), return the stop light switch 1/2 to 1 turn and secure by tightening the lock nut.

- (4) Connect the connector of the stop light switch.
- (5) Check to be sure that the stop light is not illuminated with the brake pedal unpressed.

Reference value (B): 0.5–1.0 mm (.02–.04 in.)

2. With the engine stopped, depress the brake pedal two or three times. After eliminating the vacuum in the power brake booster, press the pedal down by hand, and confirm that the amount of movement before resistance is met (the free play) is within the standard value range.

Standard value (C): 3-8 mm (.1–.3 in.)

If the free play is less than the standard value, confirm that the clearance between the stop light switch and brake pedal is within the standard value.

If the free play exceeds the standard value, it is probably due to excessive play between the clevis pin and brake pedal arm. Check for excessive clearance and replace faulty parts as required.

3. Start the engine, depress the brake pedal with approximately 500 N (110 lbs.) of force, and measure the clearance between the brake pedal and the floorboard.

Standard value (D): 80 mm (3.1 in.) or more

If the clearance is less than the standard value, check for air trapped in the brake line and for brake fluid leaks. If necessary, check the brake system mechanism (excessive shoe clearance due to faulty auto adjuster) and repair faulty parts as required.

MASTER CYLINDER

N051A--

REMOVAL AND INSTALLATION

Pre-removal Operation

- Draining of Brake Fluid

Post-installation Operation

- supplying Brake Fluid
- Bleeding
(Refer to P.5-45.)
- Adjustment of Brake Pedal
(Refer to P.5-41.)

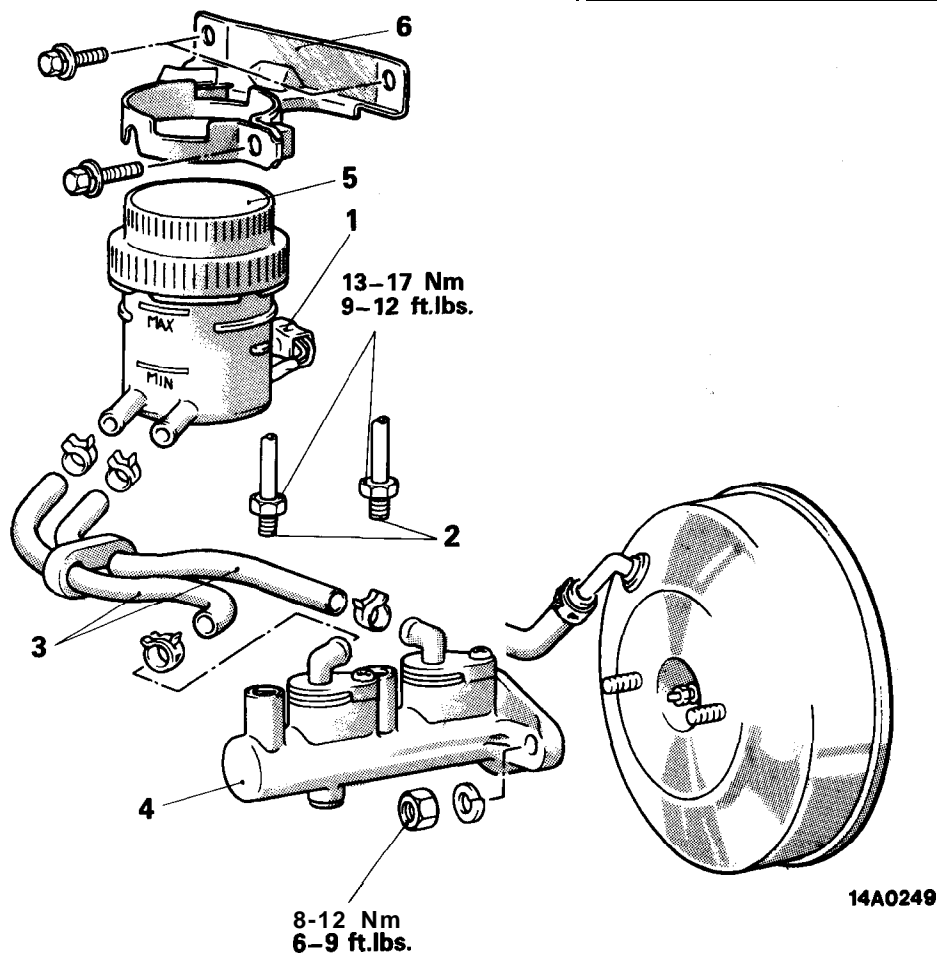

Removal steps

1. Fluid level sensor connector
2. Brake tubes
3. Reservoir hoses
4. Master cylinder
5. Reservoir
6. Bracket

- Adjustment of clearance between brake booster push rod and primary piston

NOTE

- (1) Reverse the removal procedures to reinstall.
- (2) ● +: Refer to "Service Points of Installation".

SERVICE POINTS OF INSTALLATION

N051DAO*

ADJUSTMENT OF CLEARANCE BETWEEN BRAKE BOOSTER PUSH ROD AND PRIMARY PISTON

Adjust the clearance (A) between the brake booster push rod and primary piston as follows:

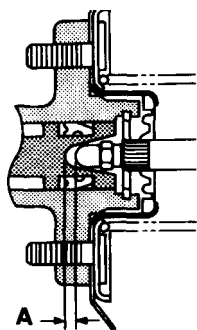

14110053

<AWD>

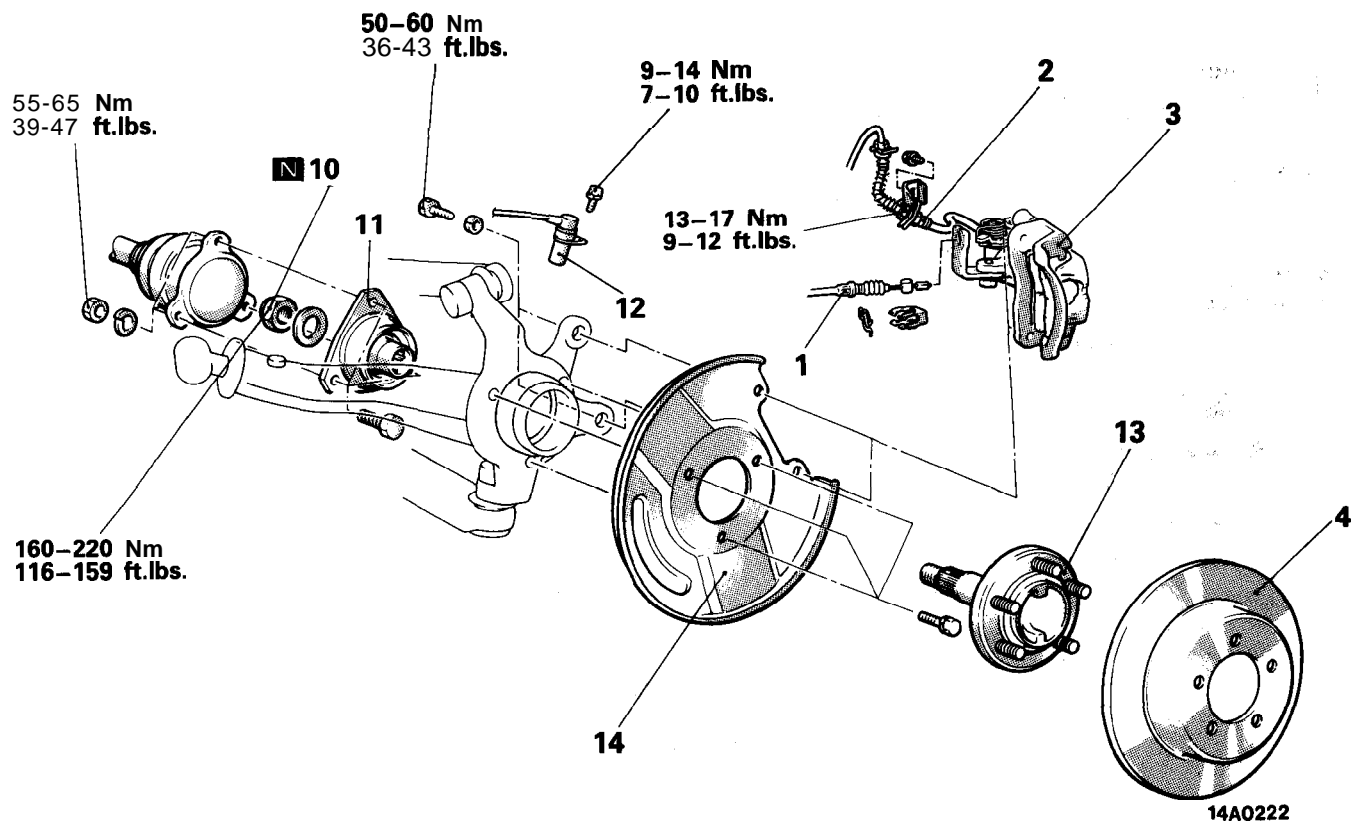

- 1. Parking brake cable connection
- 2. Brake hose connection
- 3. Rear brake assembly
- 4. Rear brake disc
- +10. Self locking nut
- 11. Companion flange
- 12. Rear speed sensor
- <<Vehicles with ABS>
- 13. Rear axle shaft

<p>Pre-removal Operation</p> <ul style="list-style-type: none"> • Draining of Brake Fluid
<p>Post-installation Operation</p> <ul style="list-style-type: none"> • supplying Brake Fluid <p>(Refer to P.5-45.)</p> <ul style="list-style-type: none"> • Adjustment of Parking Brake Level Stroke <p>P.5-42.)</p>

NOTE

- (1) Reverse the removal procedures to reinstall.
- (2) ◄◄: "Service"
- (3) ◄◄◄: Refer to "Service Points of Installation".
- (4) N: Non-reusable parts

G-SENSOR <AWD-ABS>

REMOVAL AND INSTALLATION

Pre-removal Operation

- Removal of Rear Seat
(Refer to GROUP 23–Seat.)

Post-installation Operation

- Installation of Rear Seat
(Refer to GROUP 23–Seat.)

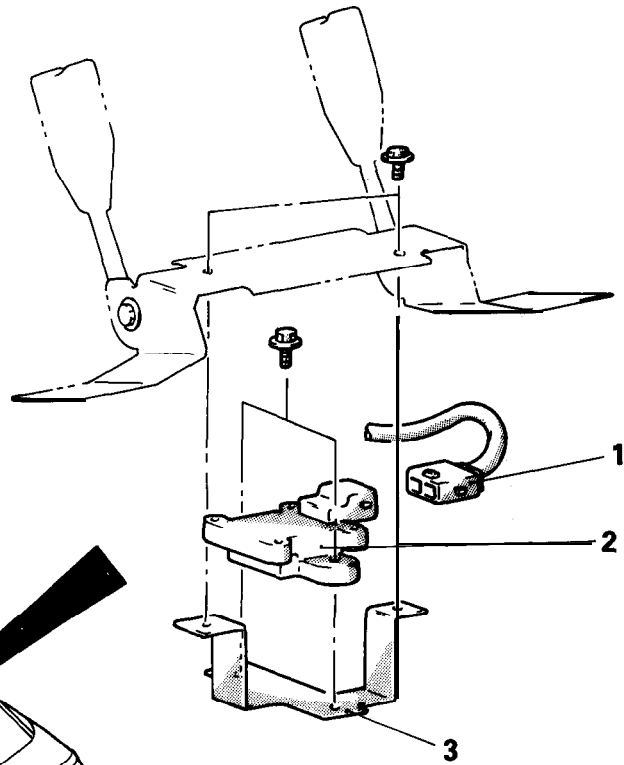
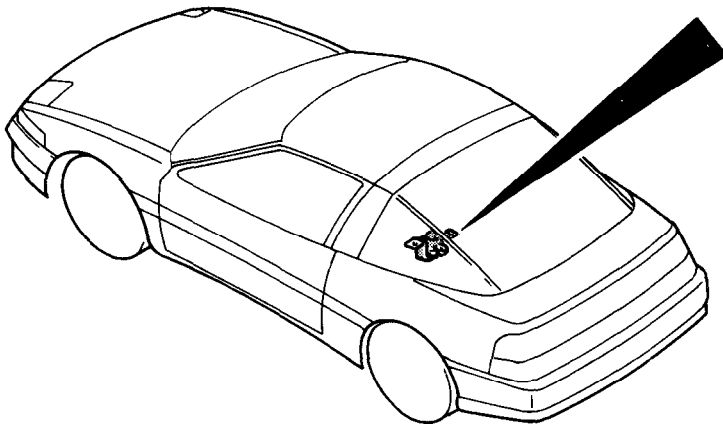

14A0565

G-sensor removal steps

1. Wiring harness connector
2. G-sensor
3. G-sensor bracket

NOTE
Reverse the removal procedures to reinstall.

INSPECTION

- (1) Place the sensor on a level surface, then check that there is conductance between the terminals.

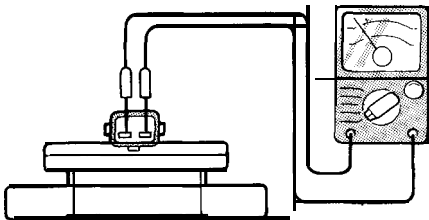

14A0194

- (2) Slowly inclining the G-sensor in the direction of forward vehicle travel, check that there is no conductance above a sensor angle of 30 degrees.

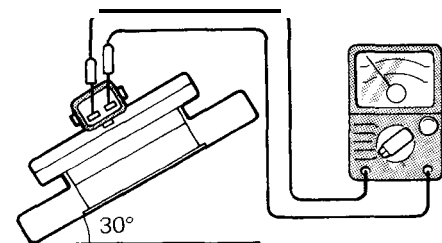

14A0195

CLUTCH MASTER CYLINDER

DISASSEMBLY AND REASSEMBLY

N06NA--

<Type A>

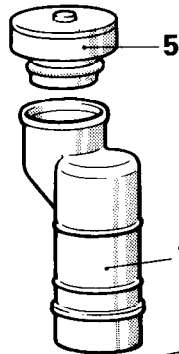

<Type B>

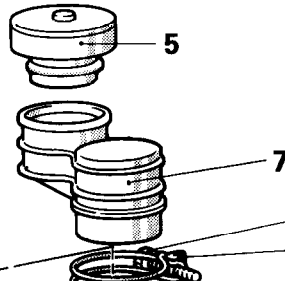
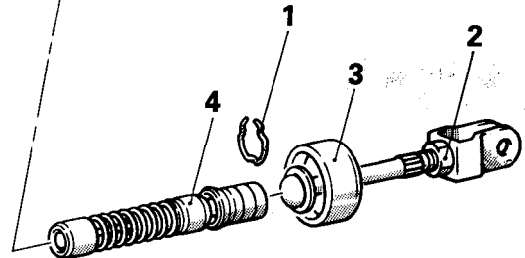
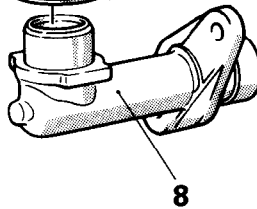
5–7 Nm
4–5 ft.lbs.

Disassembly steps

- 1. Piston stop ring
- + 2. Push rod
- 3. Boot
- ◄◄◄ 4. Piston assembly
- 5. Reservoir cap
- + 6. Reservoir band
- 7. Reservoir
- 8. Master cylinder body

NOTE

- (1) Reverse the disassembly procedures to reassemble.
- (2) ◄◄◄ : Refer to "Service Points of Disassembly".
- (3) ◄◄◄ : Refer to "Service Points of Reassembly".
- (4) <TYPE A> : Vehicles with auto-cruise control system
<TYPE B> : Vehicles without auto-cruise control system

08A0055

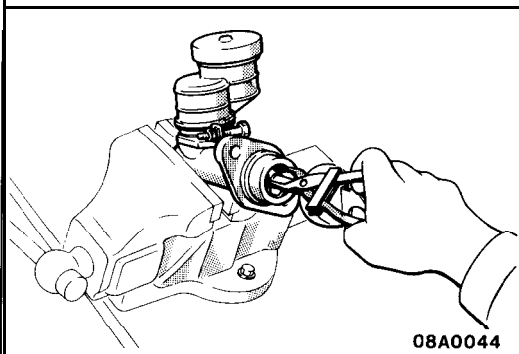

08A0044

N06NBAC

4. REMOVAL OF PISTON ASSEMBLY

Caution

1. Do not damage the master cylinder body and piston assembly.
2. Do not disassemble piston assembly.

INSPECTION

N06NCAC

- Check the inside cylinder body for rust or scars.
- Check the piston cup for wear or deformation.
- Check the piston for rust or scars.
- Check the clutch tube connection part for clogging.

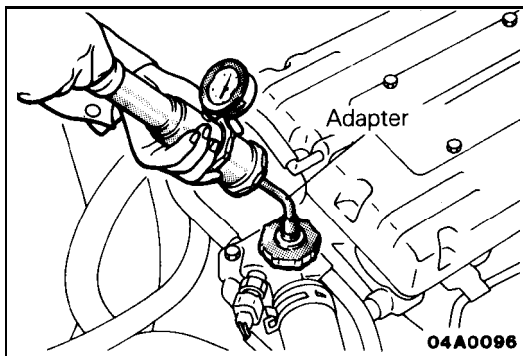

SERVICE ADJUSTMENT PROCEDURES

ENGINE COOLANT LEAK CHECK

N07FAAE

1. Loosen cap.
2. Confirm that the engine coolant level is up to the filler neck.
3. Install a adapter to the water outlet fitting and apply 160 kPa (23 psi) pressure. Hold pressure for two minutes, while checking for leakage from the radiator, hose or connections

Caution

Be sure to completely clean away moisture from the places checked.

When the tester is removed, be careful not to spill any engine coolant from it.

Be careful, when installing and removing the tester and when testing, not to deform the water outlet fitting.

4. If there is leakage, repair or replace the appropriate part.

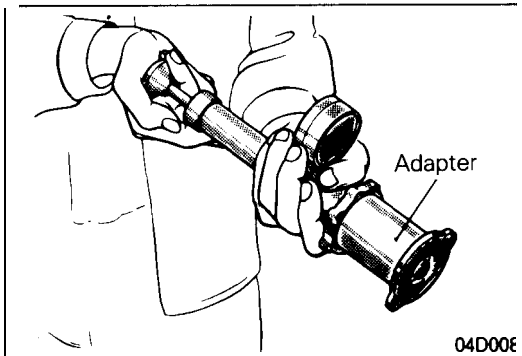

CAP PRESSURE TEST

N07FBAG

1. Use a special tool to attach the cap to the tester.
2. Increase the pressure until the indicator of the gauge stops moving.

Limit: 65 kPa (9.2 psi)

Standard value: 75–105 kPa (11–15 psi)

3. Replace the cap if the reading does not remain at or above the limit.

NOTE

Be sure that the cap is clean before testing, since rust or other foreign material on the cap seal will cause an improper indication.

ENGINE COOLANT REPLACEMENT

N07FCAC

Refer to GROUP O-Cooling System.

ENGINE COOLANT CONCENTRATION TEST

N07FDAG

Refer to GROUP O-Selection of Engine Coolant.

ALTERNATOR/WATER PUMP DRIVE BELT TENSION INSPECTION

N07FEAG

Caution

If the belt slips or squeaks, check the belt tension and also check the belt for wear, damage and breakage and check the pulleys for damage.

12. REMOVAL OF AUTOMATIC TENSIONER/14. TIMING BELT

For information concerning removal of the automatic tensioner and the timing belt, refer to GROUP 9–Timing Belt.

18. REMOVAL OF TIMING BELT B

For information concerning the removal of timing belt B, refer to GROUP 9–Timing Belt B.

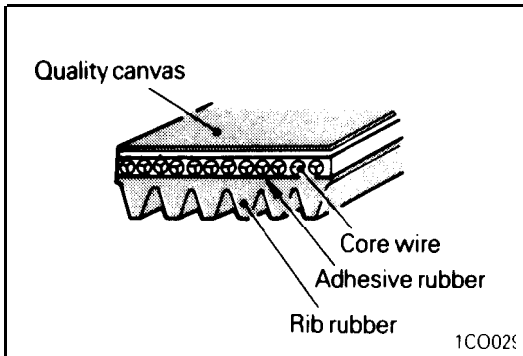
**INSPECTION**

N07MDAJ

V-RIBBED BELT

Check following items and replace if faulty.

- Check belt surface for damage, peeling or cracks.
- Check belt surface for oil or grease.
- Check belt rubber for wear or brittleness.
- Check the pulleys for cracks or damage.

WATER PUMP

- Check each part for cracks, damage or wear, and replace the water pump assembly if necessary.
- Check the bearing for damage, abnormal noise and sluggish rotation, and replace the water pump assembly if necessary.
- Check the seal unit for leaks, and replace the water pump assembly if necessary.
- Check for water leakage.

SERVICE POINTS OF INSTALLATION

N07MEAN

22. INSTALLATION OF O-RING

Insert the O-ring to the water inlet pipe, and coat the outer circumference of the O-ring with water.

By coating with water, the insertion to the water pump will become easier.

Caution

1. Care must be taken not to permit engine oil or other greases to adhere to the O-ring.
2. When inserting the pipe, check to be sure that there is no sand, dirt, etc. on its inner surface.

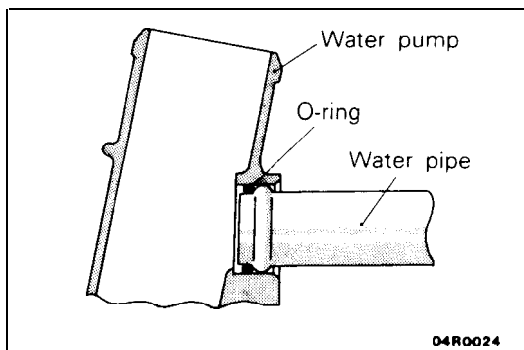

GENERAL INFORMATION

SECTIONAL VIEW <1.8L Engine>

N09BAFC

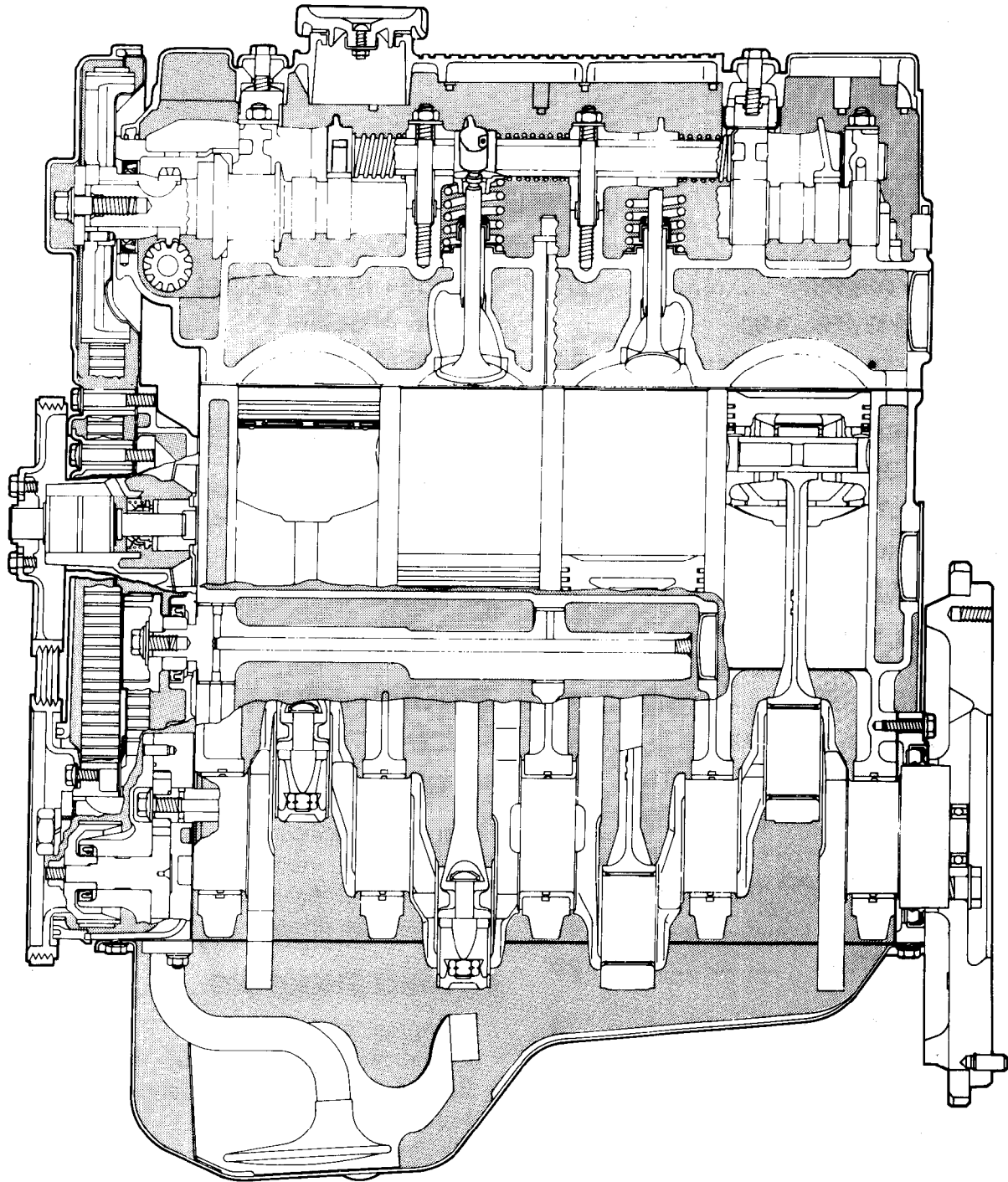

Items	Standard Value	Limit
Drive belt For alternator Deflection mm (in.) Inspection New belt Used belt Tension N (lbs.) Inspection New belt Used belt For air conditioner compressor Deflection mm (in.) Inspection New belt Used belt	 9.0– 11.5 (.354–.453) 7.5–9.0 (.295–.354) 10 (.394) 250–500(55–110) 500–700 (110–154) 400 (88) Approx. 8 (.315) 5.0–5.5 (.197–.217) 6.0–7.0 (.236–.276)	
Tension N (lbs.) Inspection New belt Used belt For power steering pump Deflection mm (in.) Inspection	 250–500(55– 110) 470–570 (104–126) 320–400 (71–88) 6.0–9.0 (.236–.354)	
Timing belt Amount of projection of auto tensioner rod mm (in.) Timing belt "B" tension mm (in.) Amount of projection of auto tensioner rod mm (in.) (distance between the tensioner arm and auto tensioner body) Auto tensioner rod retraction rpm	 12 (.47) 5 - 7 (.20–.28) 3.8-4.5 (.15–.18) 2.5-3	

NOTE

- O.D.: Outer Diameter
- I.D.: Inner Diameter
- O.S.: Oversize Diameter
- U.S.: Undersize Diameter

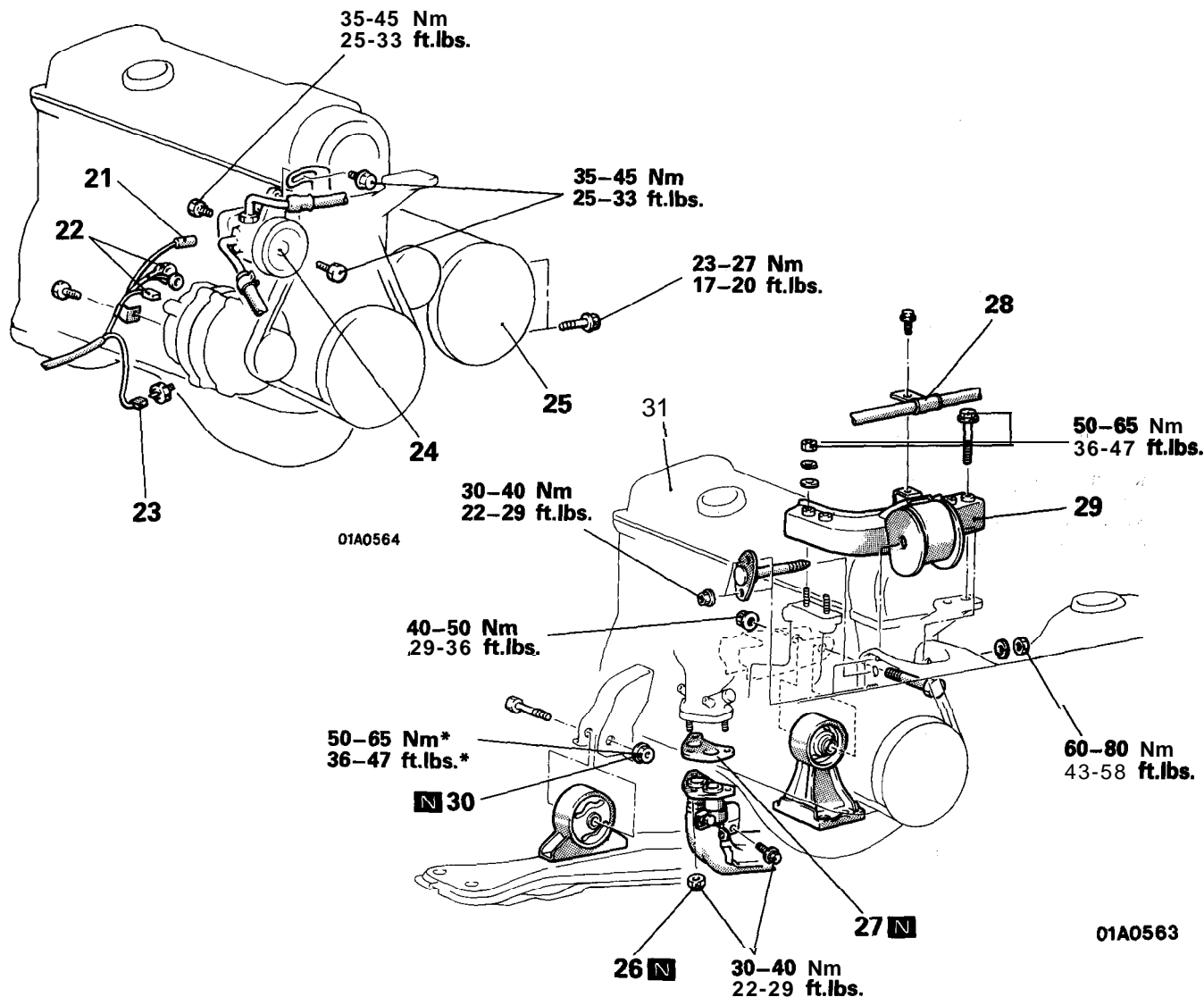

Removal steps

- 21. Connection for power steering oil pump switch
- 22. Connection for alternator
- 23. Connection for oil pressure switch
- ◆◆ ● + 24. Power steering oil pump
- ◆◆ ● 4 25. Air conditioner compressor
- 26. Self-locking nuts
- 27. Gasket
- 28. Clamp of pressure hose (Power steering)
- ◆◆ 29. Engine mount bracket

- 30. Self-locking nut
- ◆◆◆◆ 31. Engine assembly

NOTE

- (1) Reverse the removal procedures to reinstall.
- (2) ● *: Refer to "Service Points of Removal".
- (3) ● *: Refer to "Service Points of Installation".
- (4) N : Non-reusable parts
- (5) For tightening locations indicated by the * symbol, first tighten temporarily, and then make the final tightening with the entire weight of the engine applied to the vehicle body.

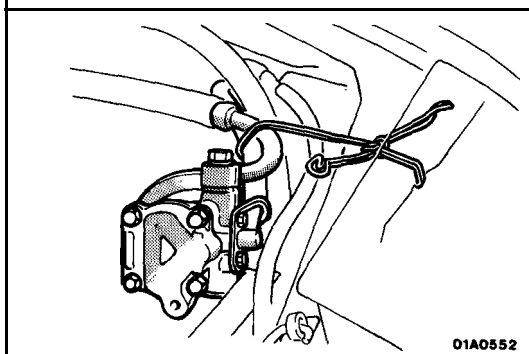

SERVICE POINTS OF REMOVAL

N095B8C

24. REMOVAL OF POWER STEERING OIL PUMP

Remove the oil pump (with the hose attached).

NOTE

Suspend the removed oil pump (by using wire or similar material) at a place where no damage will be caused during removal/installation of the engine assembly.

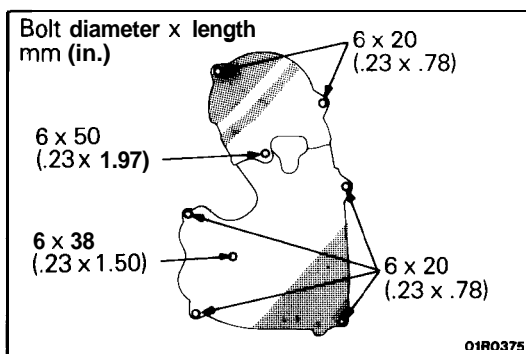
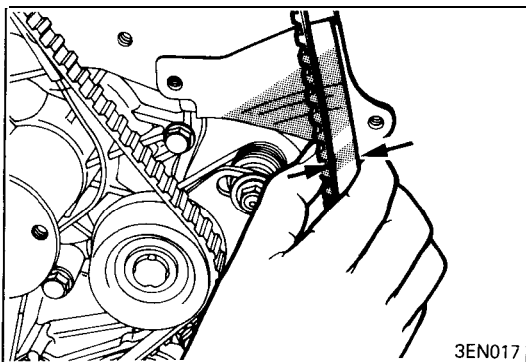
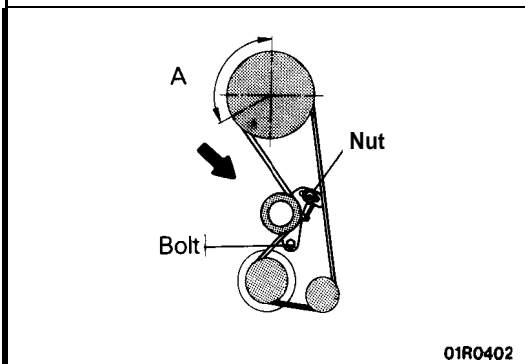
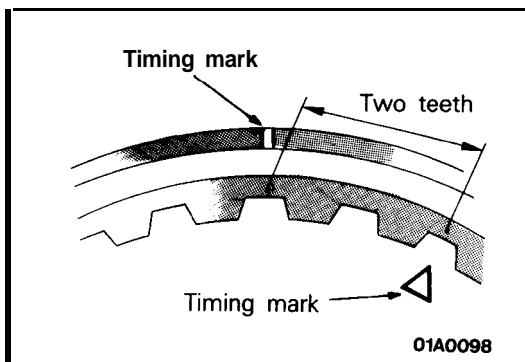

- (3) Turn the crankshaft clockwise by two teeth of the camshaft sprocket.

Caution

As the purpose of this procedure is to apply the proper amount of tension on the timing belt, be sure not to rotate the crankshaft counterclockwise or place pressure on the belt to check the amount of tension.

- (4) Apply force on tensioner toward turning direction, (in the direction of the arrow) such that no portion of the belt raises out in portion A, place the belt on the camshaft sprocket such that the belt sprocket teeth are fully engaged.
- (5) Tighten the tensioner installation bolt and tensioner spacer in that order.

Caution

If the tensioner spacer is tightened first, the tensioner will rotate with it and belt tension be thrown out of adjustment. Always tighten the bolt first.

- (6) Check to see that the clearance between the outside of the belt and the cover are within the standard value by grasping the tension side (between the camshaft sprocket and oil pump sprocket) of the centre part of the timing belt between the thumb and index finger. Standard value: 12 mm (.40 in.)

14. INSTALLATION OF TIMING BELT FRONT LOWER COVER/12. TIMING BELT FRONT UPPER COVER

Note that the timing belt lower and upper cover attaching bolts differ in size from one place to another.

6. TENSION ADJUSTMENT OF THE ALTERNATOR DRIVE BELT
Refer to GROUP 14–Service Adjustment Procedures.
5. TENSION ADJUSTMENT OF THE AIR CONDITIONER COMPRESSOR DRIVE BELT
Refer to GROUP 24– Service Adjustment Procedures.
3. DEFLECTION ADJUSTMENT OF POWER STEERING OIL PUMP DRIVE BELT
Refer to GROUP 19–Service Adjustment Procedures.

OIL RELIEF PLUNGER

- (1) Check that the relief plunger slides smoothly.
- (2) Check the relief spring for breakage.

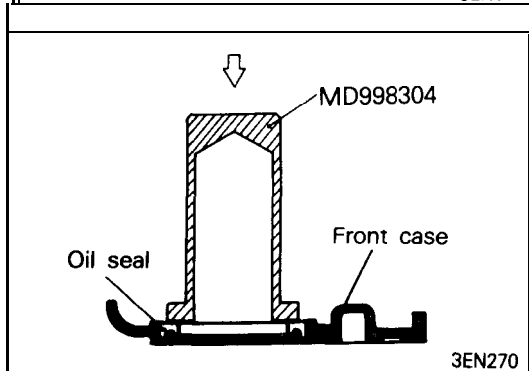
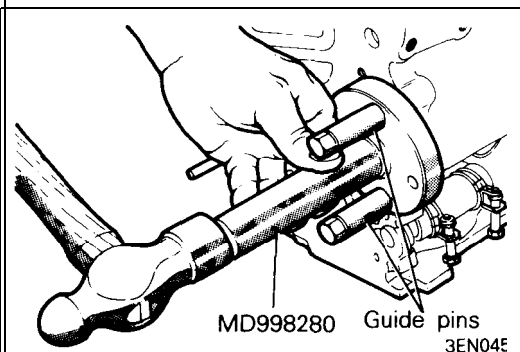
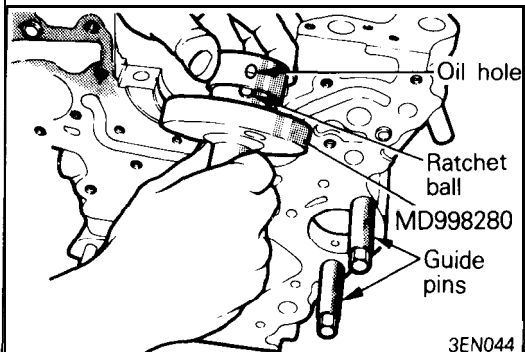
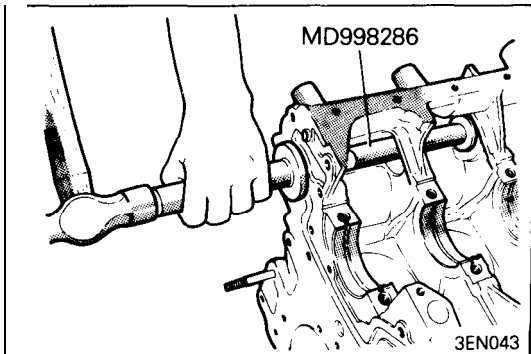

SERVICE POINTS OF REASSEMBLY

N09RHAF

27. INSTALLATION OF SILENT SHAFT REAR BEARING

- (1) Apply engine oil to the rear bearing outer circumference and bearing hole in cylinder block.
- (2) Using the special tool and a hammer, drive the rear bearing into cylinder block.

26. INSTALLATION OF SILENT SHAFT FRONT BEARING

- (1) Install two guide pins included in the special tool set to the threaded holes in cylinder block.
- (2) Set the front bearing on the special tool so that the ratchet ball of special tool fits in the oil hole in bearing.
- (3) Apply engine oil to the bearing outer circumference and bearing hole in cylinder block.

- (4) Set the special tool on guide pins and drive the bearing into cylinder block.

22. INSTALLATION OF CRANKSHAFT OIL SEAL

Using the special tool, install the crankshaft oil seal into front case.

ENGINE MOUNTING

REMOVAL AND INSTALLATION

Pre-removal Operation

- Raise and Suspend the Engine to the Extent Force is not applied to the Engine Mount

Post-installation Operation

- Lower the Engine

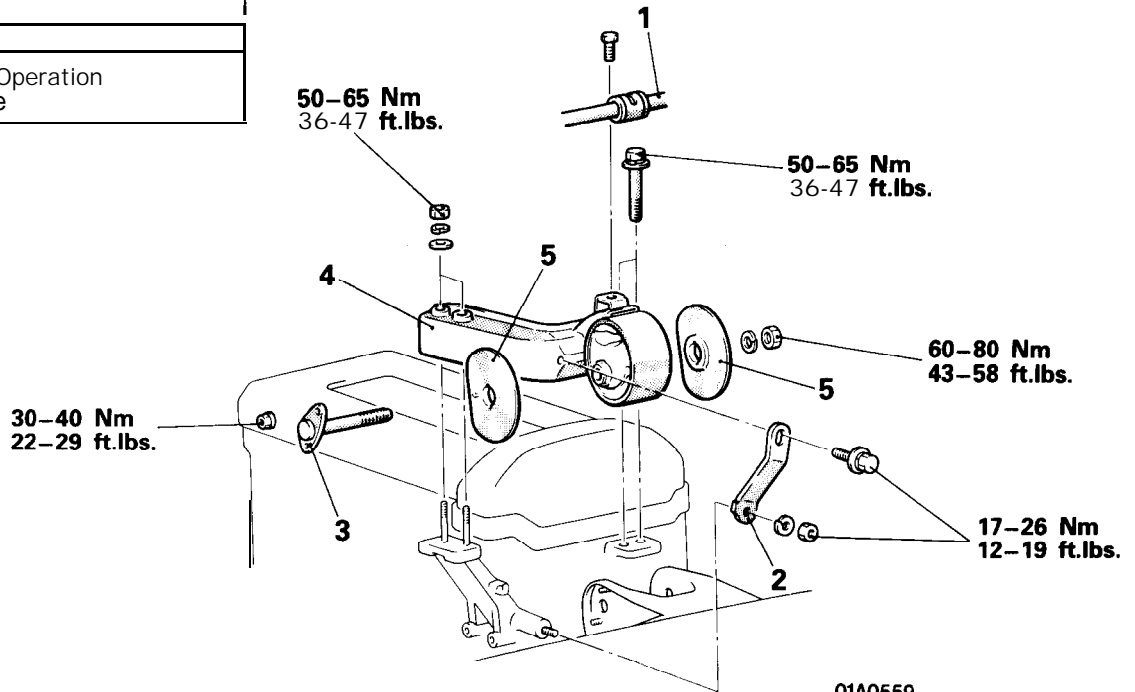

Removal steps

1. Pressure hose (power steering)
2. Bracket
3. Engine mount bracket and body connection bolt
4. Engine mount bracket
- + 5. Mounting stopper

NOTE

- (1) Reverse the removal procedures to reinstall.
- (2) ◆◆: Refer to "Service Points of Installation".

INSPECTION

N09GCAH3

- Check each insulator for cracks or damage.
- Check each bracket for deformation or damage.

SERVICE POINTS OF INSTALLATION

N09GDAK1

5. INSTALLATION OF MOUNTING STOPPER

Install the mounting stopper of the engine mount bracket so that the arrow faces the center part of the engine.

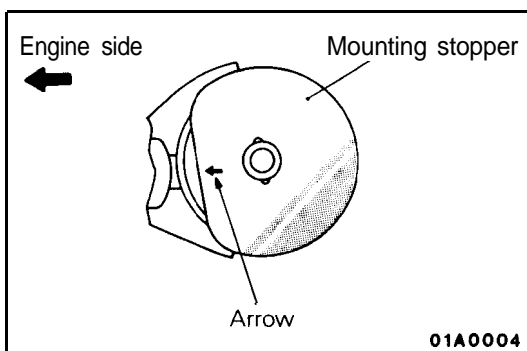

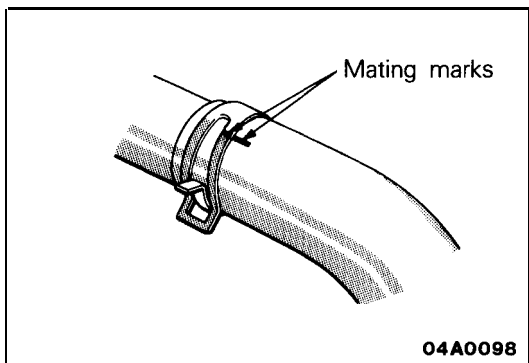

SERVICE POINTS OF REMOVAL

17. REMOVAL OF RADIATOR UPPER HOSE

Make mating marks on the radiator hose and hose clamp, and then disconnect the radiator hose.

25. DISCONNECTION OF HIGH PRESSURE FUEL HOSE

Caution

Cover the hose connection with rags to prevent splash of fuel that could be caused by some residual **pressure** in the fuel pipe line.

For information concerning the bleeding of the residual pressure, refer to GROUP 14–Service Adjustment Procedures.

39. REMOVAL OF TIMING BELT

Refer to P.9-98.

47. REMOVAL OF CYLINDER HEAD ASSEMBLY

Using the special tool, loosen the bolts in the order shown in the figure (in 2 or 3 cycles) and remove. Then remove the cylinder head assembly.

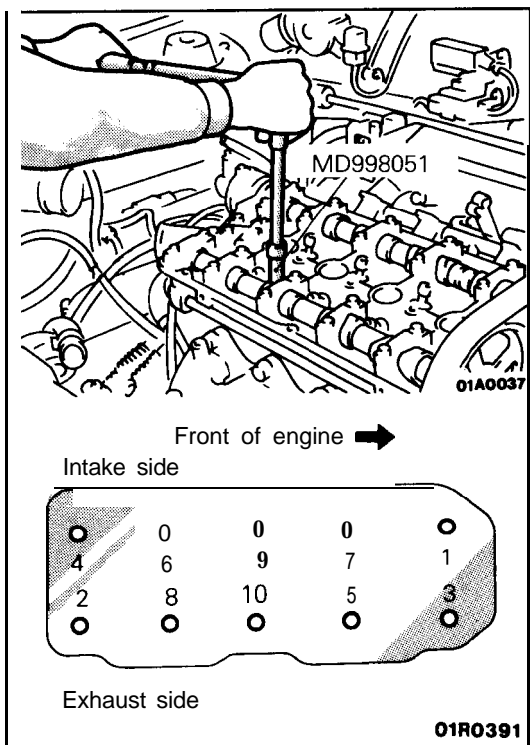

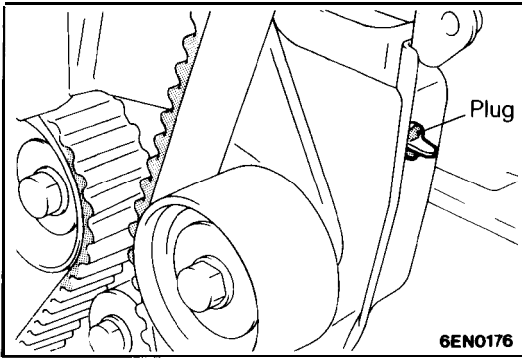

(8) Install the rubber plug to the timing belt rear cover.

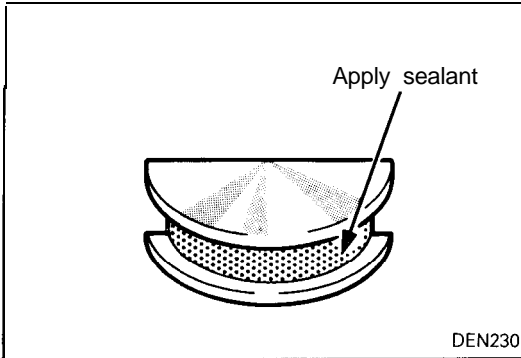

19. APPLICATION OF SEALANT ON SEMI-CIRCULAR PACKING

Apply sealant on the periphery of the semi-circular packing.

Specified sealant: MOPAR Part No. 4318034 or equivalent

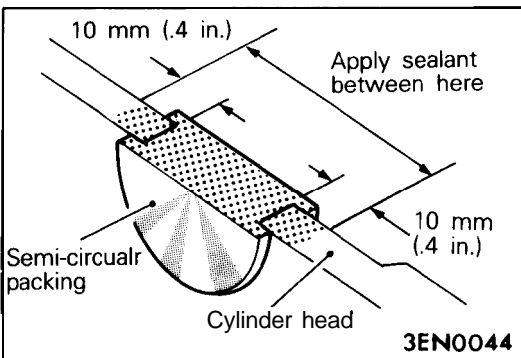

18. APPLICATION OF SEALANT ON ROCKER COVER

Apply sealant to the areas indicated in the illustration.

Specified sealant: MOPAR Part No. 4318034 or equivalent

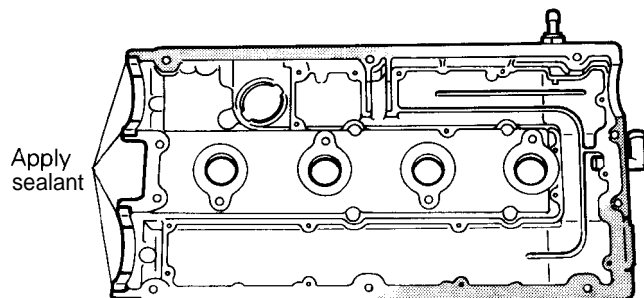
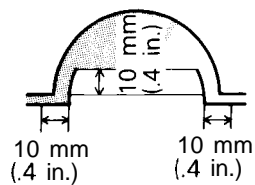

6EN0286

SERVICE POINTS OF REASSEMBLY**36. INSTALLATION OF OIL JET**

When installing the oil jet, make sure that the nozzle is in correct direction, that is, toward the piston.

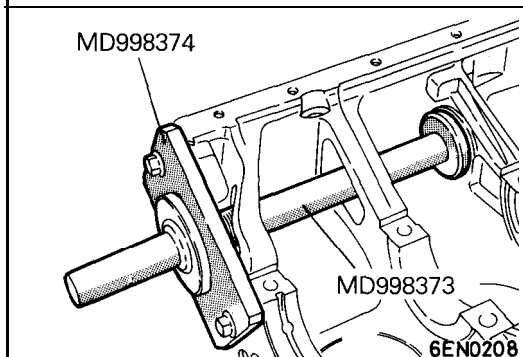
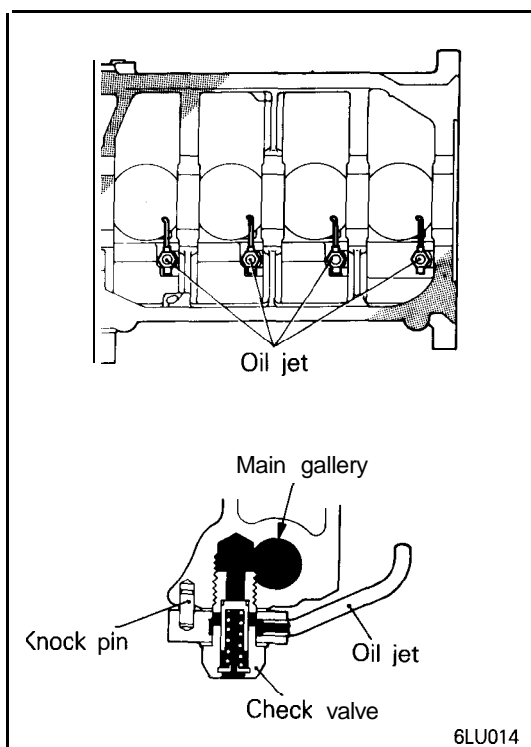
**33. INSTALLATION OF LEFT SILENT SHAFT REAR BEARING**

- (1) Install the special (GUIDE PLATE) tool to the cylinder block.
- (2) Apply engine oil to the rear bearing outer circumference and bearing hole in cylinder block.

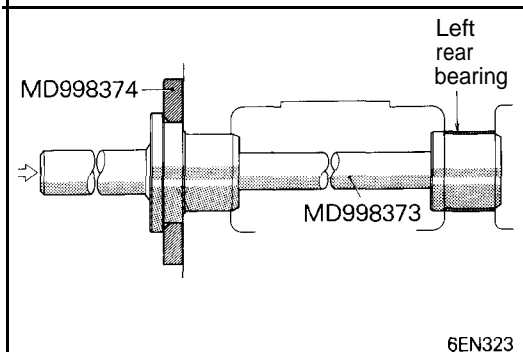

- (3) Using the special tool, install the rear bearing.

NOTE

The left rear bearing has no oil holes.

- (3) If the distortion is excessive, correct within the allowable limit or replace.

Grinding limit: 0.2 mm (.008 in.)

The total thickness of the stock allowed to be removed from cylinder block and mating cylinder head is 0.2 mm (.008 in.) at maximum.

Cylinder block height (when new): 284 mm (11.18 in.)

- (4) Check cylinder walls for scratches and seizure. If defects are evident, correct (bored to oversize) or replace.
- (5) Using cylinder gauge, measure the cylinder bore and cylindricity. If worn badly, correct cylinder to an oversize and replace piston and piston rings. Measure at the points shown in illustration.

Standard value:

Cylinder I.D.: 85.00–85.03 mm (3.3485-3.3476 in.)

**Out-of-roundness and taper of cylinder bore:
0.01 mm (.0004 in.) or less**

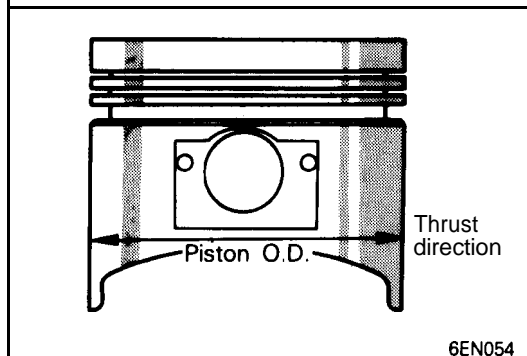
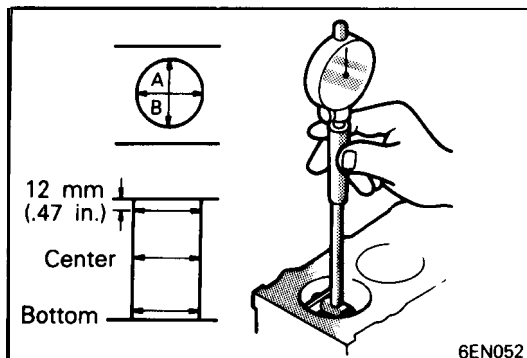

CYLINDER REBORING

N09VEDCa

- (1) Oversize pistons to be used should be determined on the basis of the largest bore cylinder.

Piston size identification

Size	Identification mark
0.25 mm (.01 in.) O.S.	0.25
0.50 mm (.02 in.) O.S.	0.50
0.75 mm (.03 in.) O.S.	0.75
1.00 mm (.04 in.) O.S.	1.00

NOTE

Size mark is stamped on piston top.

- (2) Measure outside diameter of piston to be used. Measure it in thrust direction as shown.
- (3) Based on measure piston O.D. calculate boring finish dimension.

Boring finish dimension = Piston O.D. + (clearance between piston O.D. and cylinder) – 0.02 mm (.0008 in.) (honing margin)

- (4) Bore all cylinders to calculated boring finish dimension.

Caution

To prevent distortion that may result from temperature rise during honing, bore cylinders, working from No. 2 to No. 4 to No. 1 to No. 3.

- (5)hone to final finish dimension (piston O.D. + clearance between piston O.D. and cylinder).
- (6) Check clearance between piston and cylinder.

Clearance between piston and cylinder:

<Non-Turbo>: **0.02–0.04 mm (.0008–.0016 in.)**

<Turbo>: **0.03–0.05 mm (.0012–.0020 in.)**

NOTE

When boring cylinders, finish all of four cylinders to same oversize. Do not bore only one cylinder to an oversize.

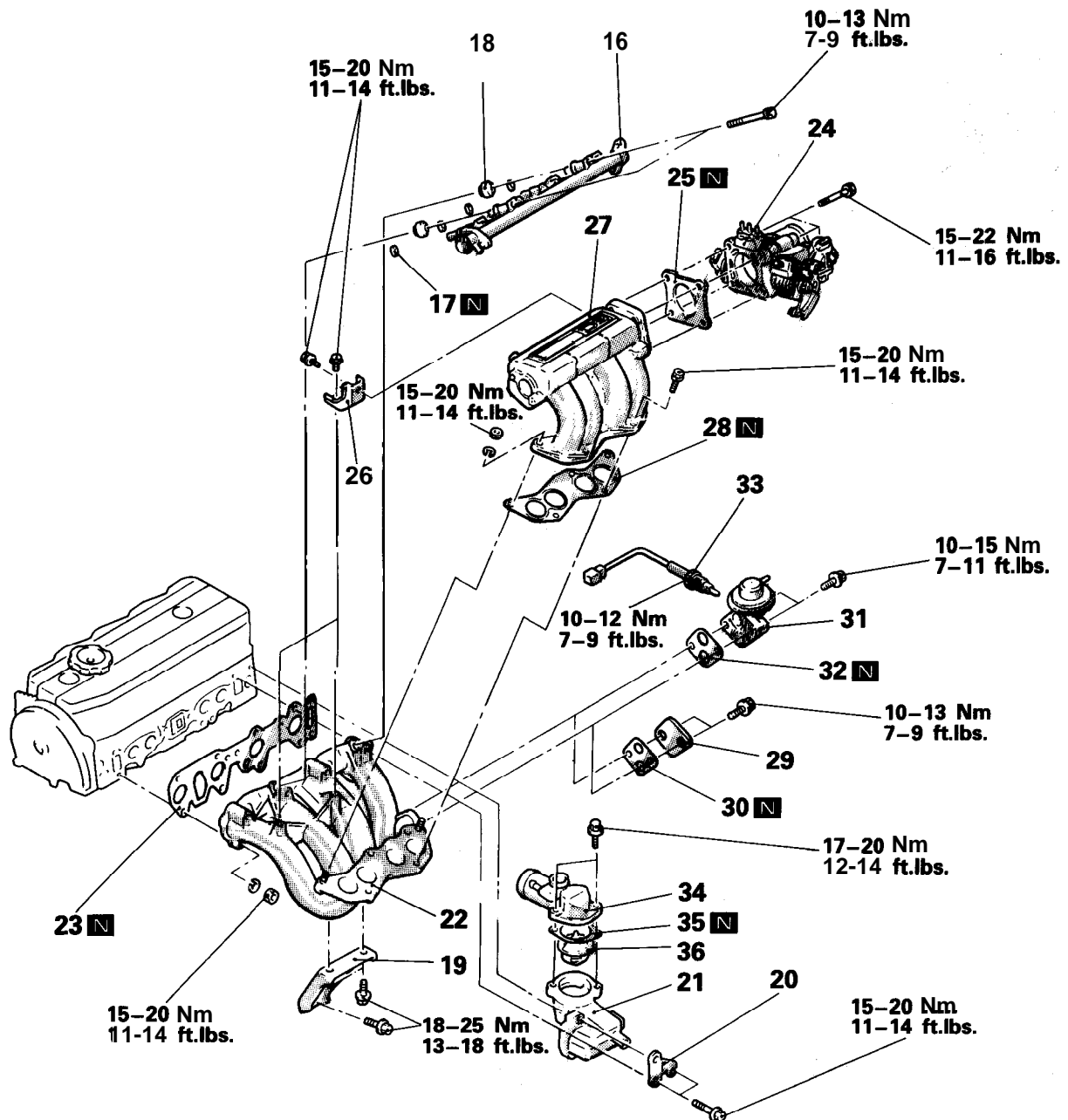

05A0180

Removal steps

- ◆◆ ● ◆ 16. Delivery pipe, fuel injector and pressure regulator
- 17. Insulator
- 18. Insulator
- 19. Intake manifold stay
- 20. Engine hanger
- 21. Thermostat housing
- 22. Intake manifold
- 23. Intake manifold gasket
- 24. Throttle body assembly
- 25. Gasket
- 26. Air intake plenum stay
- 27. Air intake plenum
- 28. Air intake plenum gasket

- ◆ 29. Cover <Vehicles for Federal and Canada>
- 30. Gasket <Vehicles for Federal>
- 31. EGR valve <Vehicles for California>
- 32. EGR gasket <Vehicles for California>
- 33. EGR temperature sensor <Vehicles for California>
- 34. Water outlet fitting
- 35. Gasket
- 36. Thermostat

NOTE

- (1) Reverse the removal procedures to reinstall.
- (2) ◆◆: Refer to "Service Points of Removal".
- (3) ●*: Refer to "Service Points of Installation"
- (4) □: Non-reusable parts

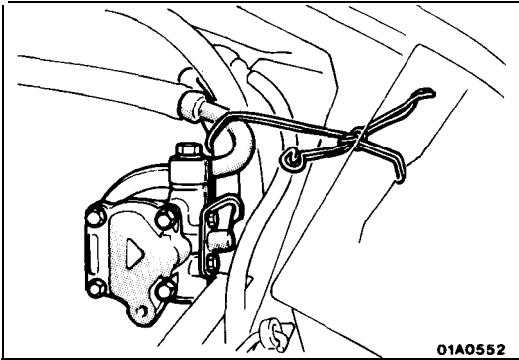

SERVICE POINTS OF REMOVAL

N11NBAI

11. DISCONNECTION OF POWER STEERING OIL PUMP :

Disconnect the oil pump with hoses from the bracket.

NOTE

The removed power steering oil pump should be fastened (by using rope, etc.) in a position that will not interfere with the removal/installation of the exhaust manifold.

INSPECTION

N11NCAL1

Check the following points; replace the part if a problem is found.

EXHAUST MANIFOLD

Check for damage or cracking of any part.

EXHAUST MANIFOLD GASKET

Check for flaking or damage of the gasket.

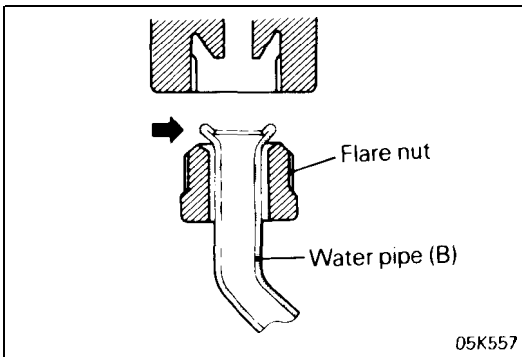

SERVICE POINTS OF INSTALLATION

N11NDAG

18. INSTALLATION OF WATER PIPE (B)

Before installing to the water inlet pipe, apply machine oil to the inner surface of the pipe flare.

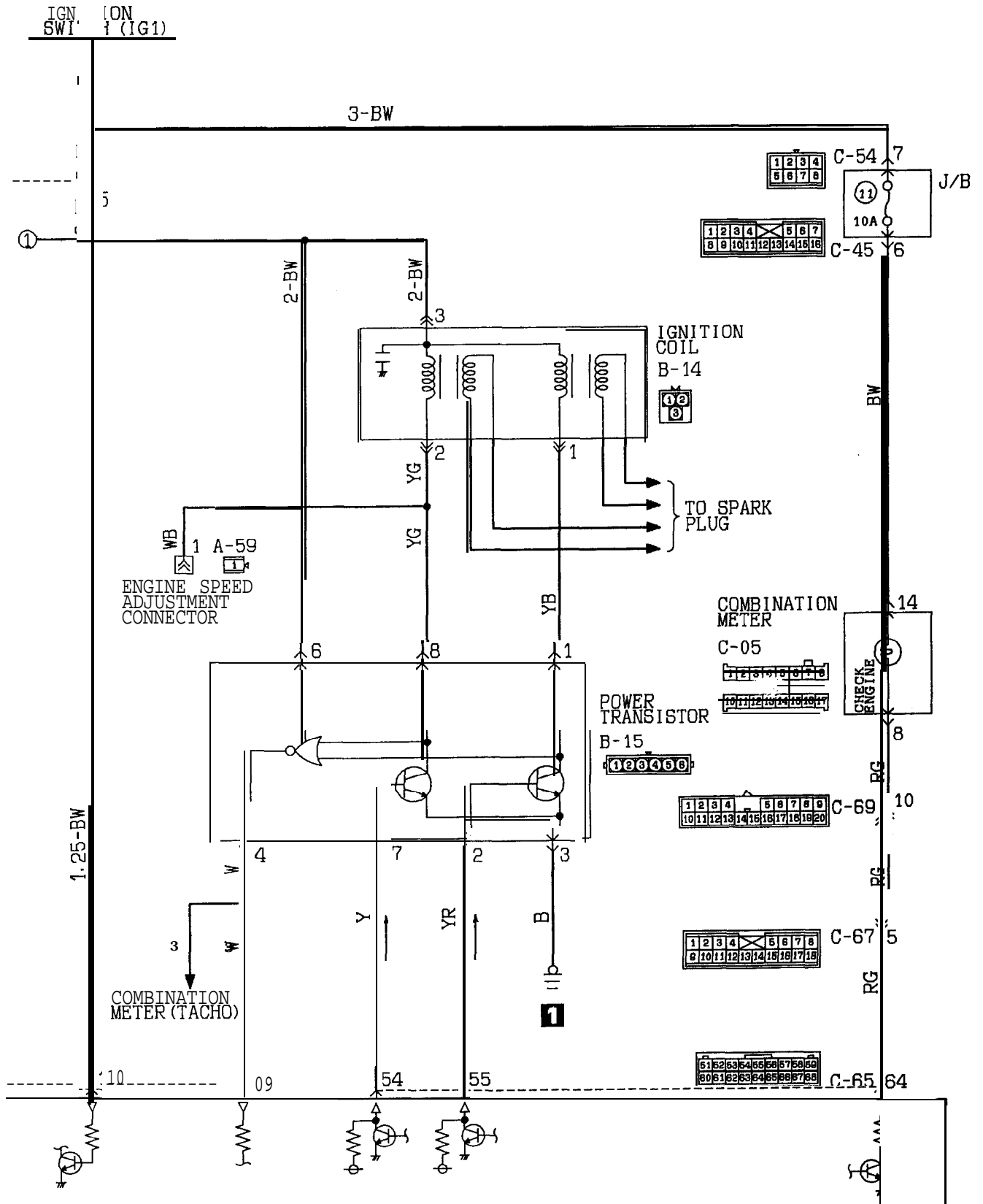

14-42 FUEL SYSTEM – Service Adjustment Procedures <1.8L Engine>

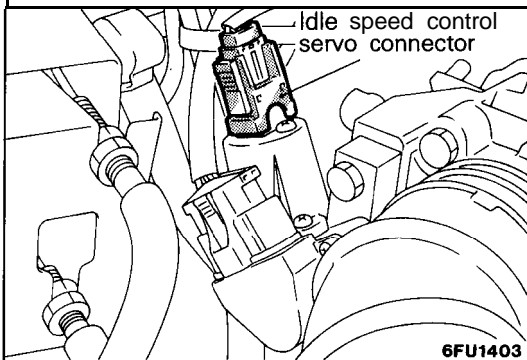
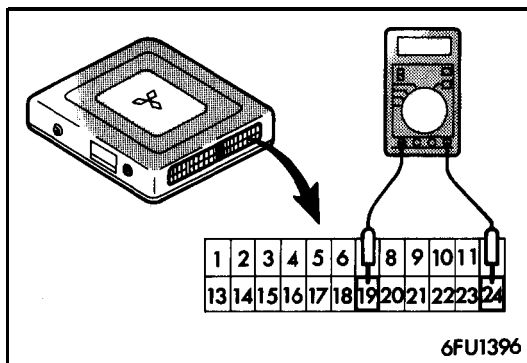

- (3) Connect a digital voltmeter between terminal 19 (throttle position sensor output voltage) of the engine control unit and terminal 24 (ground).
- (4) Set the ignition switch at ON (without starting the engine) hold it in that position for more than 15 seconds or more.
- (5) Set the ignition switch at OFF.

- (6) Disconnect the connectors of the idle speed control servo and lock the idle speed control plunger at the initial position.
- (7) Back out the fixed SAS enough.

- (8) Start the engine and let it run at idle.
- (9) Check to ensure that the engine is running at the standard basic idle speed.

Basic idle speed: 700 ± 50 rpm

Caution

1. On a new vehicle [driven less than 500 km (300 miles)], the engine speed may be 20 to 100 rpm lower, but no adjustment is necessary.
2. If the engine stalls or the engine speed is low after the vehicle has been driven a distance of 500 km (300 miles) or more, a deposit on the throttle valve area is suspected. Clean the throttle valve area.

- (10) If the engine speed does not conform to the standard value, adjust it with the idle speed control adjusting screw.

Caution

When adjusting the idle speed control, use a hexagon wrench whenever possible.

- (11) Turn in the fixed SAS until the engine speed rises. Then back out the fixed SAS until the "touch point" where the engine speed does not fall any longer is found. Back out the fixed SAS an additional half a turn from the touch point.
- (12) Stop the engine.

- (13) Set the ignition switch at ON (do not start the engine) and check that the output voltage from the throttle position sensor is as specified.

Standard value: $0.48-0.52$ V

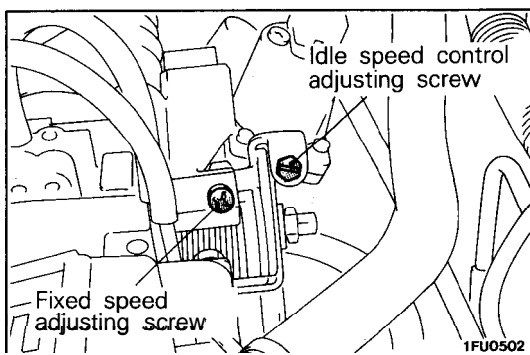

EGR control solenoid valve [Calif. only]
Purge control solenoid valve

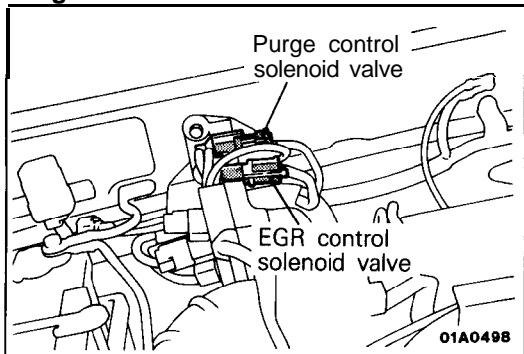

ISC servo, Idle position switch, MPS

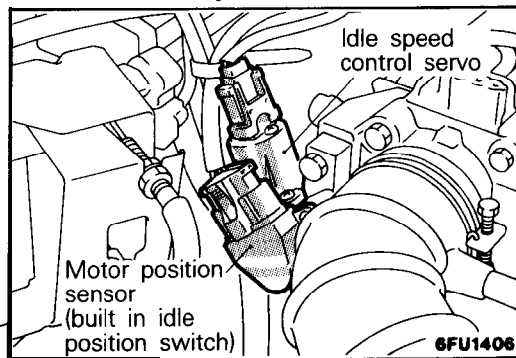

Crankshaft angle sensor, TDC sensor
Ignition coil, Power transistor

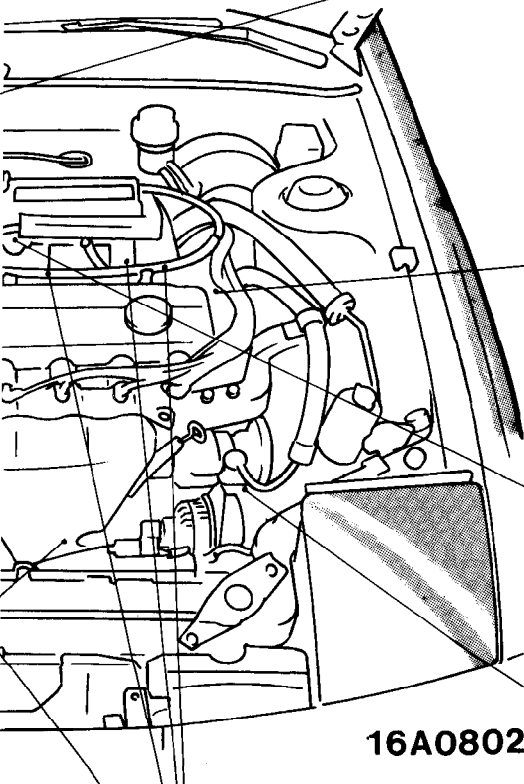
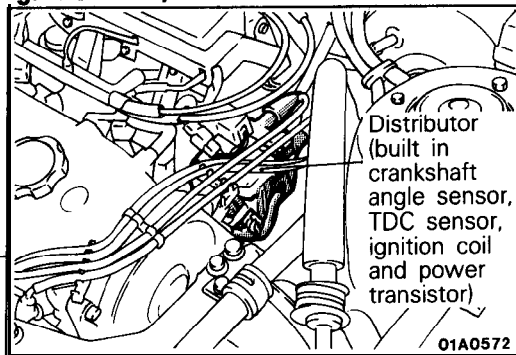

EGR temperature sensor [Calif. only]

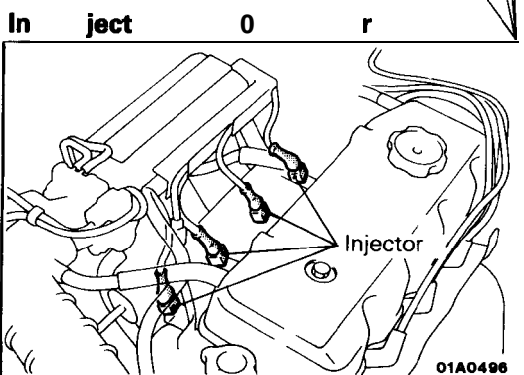
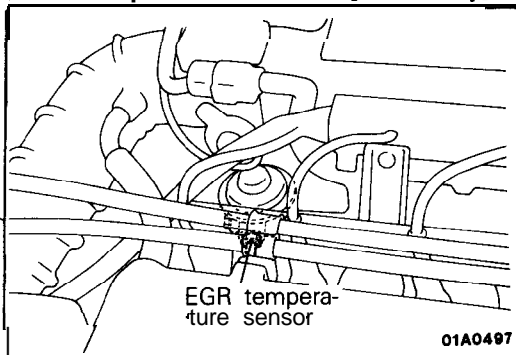

Power steering fluid pressure switch

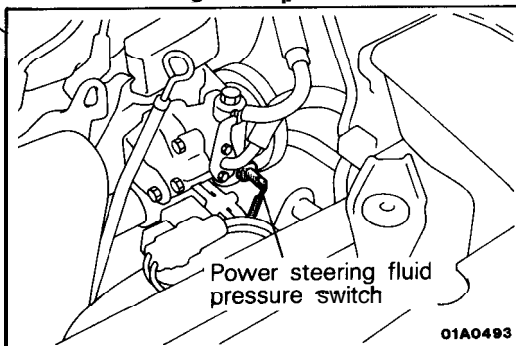

MALFUNCTION INDICATOR LIGHT

N14PQAC

Among the self-diagnosis items, a malfunction indicator light comes on to notify the driver of the emission control items when an irregularity is detected.

However, when an irregular signal returns to normal and the engine control unit judges that it has returned to normal, the malfunction indicator light goes out.

Moreover, when the ignition switch is turned off, the light goes out. Even if the ignition switch is turned on again, the light does not come on until the irregularity is detected.

Here, immediately after the ignition switch is turned on, the malfunction indicator light is lit for 5 seconds to indicate that the malfunction indicator light operates normally.

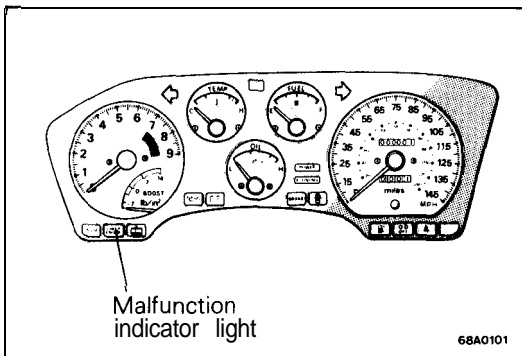
**Items indicated by the lighting malfunction light**

Engine control unit
Oxygen sensor
Air flow sensor
Intake air temperature sensor
Throttle position sensor
Engine coolant temperature sensor
Crank angle sensor
Top dead center sensor
Barometric pressure sensor
Detonation sensor <Turbo>
Injector
Fuel pump
EGR <California>
Ignition coil

MALFUNCTION INDICATOR LIGHT INSPECTION

When turning on the ignition switch, check that the light comes on.

NOTE

If the light does not come on, check the harness and light for breakage.

N14SHACa

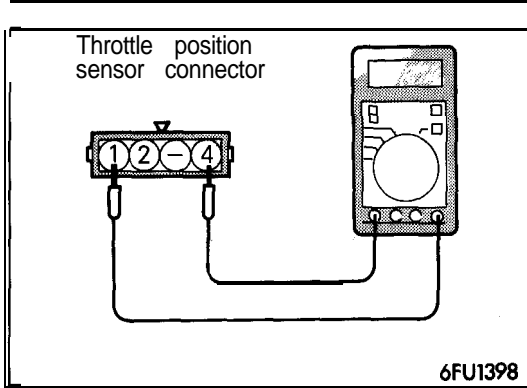

INSPECTION

THROTTLE POSITION SENSOR CONTINUITY CHECK

- (1) Measure resistance between terminals ① and ④ of the throttle position sensor using a circuit tester.

Standard value: 3.5-6.5 kΩ

- (2) Check sensor body for cracks and damages.

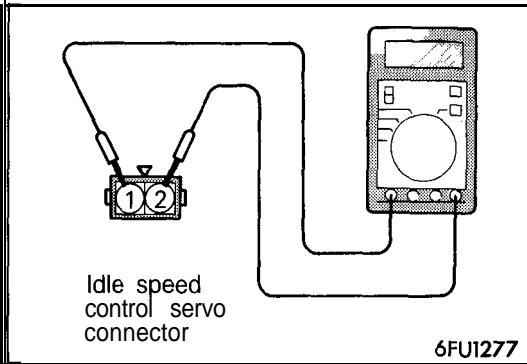

IDLE SPEED CONTROL SERVO CONTINUITY CHECK

Measure resistance between terminals ① and ② using a circuit tester.

Standard value: 5-35 Ω [at 20°C (68°F)]

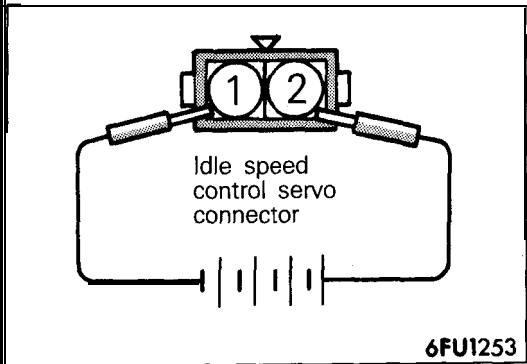

IDLE SPEED CONTROL SERVO OPERATION INSPECTION

Caution

Apply only a **6V DC** or lower voltage. Application of higher voltage could cause locking of the servo gears.

- (1) Connect 6V DC to terminals ① and ② and check that the idle speed control servo extends and retracts by itself.

	Idle speed control servo motion
When terminal ① is ⊕	Retracts
When terminal ② is ⊕	Extends

- (2) If the idle speed control servo does not move, replace the idle speed control servo assembly.

THROTTLE BODY COMPONENTS CLEANING

- (1) Clean all components, but the following components must not be cleaned by using a cleaning agent.

- Throttle position sensor
- Idle speed control servo assembly

The insulation of these components will be damaged if they are immersed in a cleaning agent. They should be cleaned by using only a piece of cloth.

- (2) Check for clogging of the vacuum port or passage. Clean the vacuum passage by using compressed air.

FUEL LINE AND VAPOR LINE

REMOVAL AND INSTALLATION

N14KA--

Pre-removal Operation

- Removal of the Battery Tray (Refer to GROUP 8-Starter Motor)
- Release of Residual Pressure from High Pressure Hose. (Refer to P.14-44.)

Post-installation Operation

- Measurement of Fuel Pressure (Refer to P.14-44, 52.)
- Installation of the Battery Tray (Refer to GROUP 8-Starter Motor)

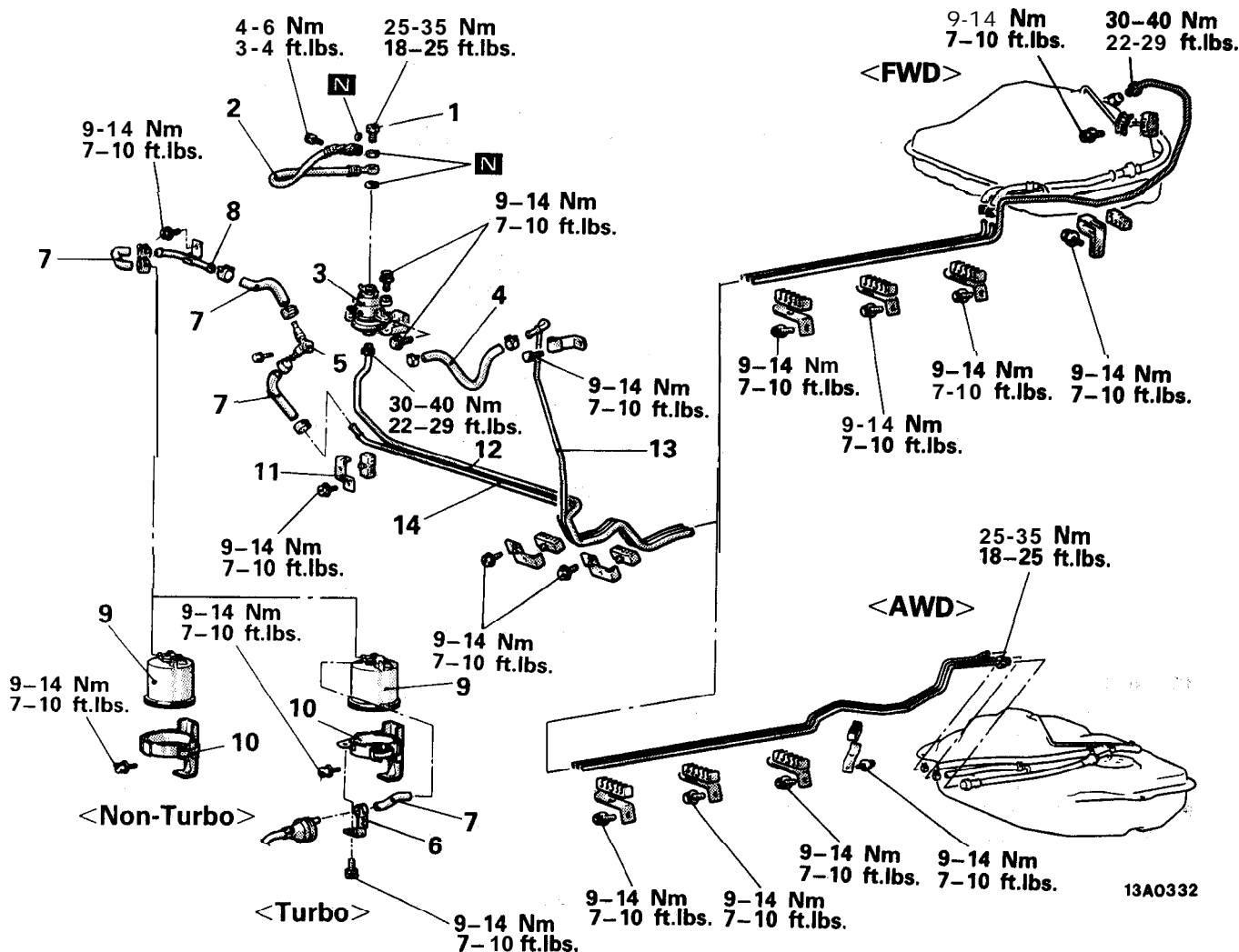

13A0332

Removal steps

- ☒ 1. Eye bolt
- + 2. High pressure fuel hose
- ◄► ● + 3. Fuel filter
- ◄◄ 4. Fuel return hose
- 5. Check valve
- 6. Clamp
- ◄◄ 7. Fuel vapor hose
- 8. Vapor pipe assembly
- 9. Canister
- 10. Canister holder
- * ● * 11. Clamp
- 12. Fuel main pipe
- 13. Fuel return pipe
- 14. Fuel vapor pipe

NOTE

- (1) Reverse the removal procedures to reinstall.
- (2) ◄◄ : Refer to "Service Points of Removal".
- (3) ● * : Refer to "Service Points of Installation".
- (4) ☒ : Non-reusable parts

6. CHECKING THE STOP LIGHT SWITCH CIRCUIT

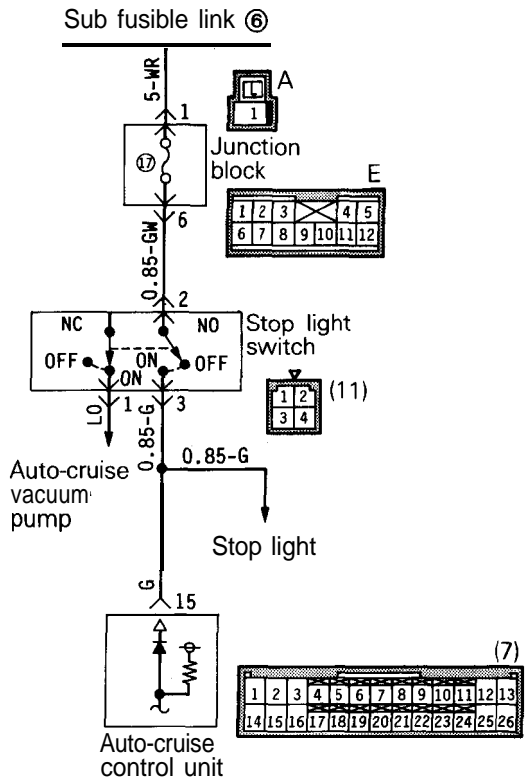

13A0368

Description of operation

When the brake pedal is depressed during constant-speed travel, the stop light switch's (NC) contacts for the cruise-control system open, with the result that the current to the auto-cruise vacuum pump is interrupted, thus canceling the constant-speed travel.

At the same time, moreover, the closing of the (NO) contacts for the stop light results in the sending of the cancel signal to the control unit, so that the auto-cruise vacuum pump current is discontinued within the control unit, thereby canceling the constant-speed travel.

The flow of current is from the sub fusible link (6) to fuse No. (17) of the junction block, the stop light switch, and the control unit.

Troubleshooting hint

ECU terminal voltage

Terminal No.	Signal	Conditions	Terminal voltage
15	Stop light switch (load side)	When the brake pedal is depressed.	System voltage
		When the brake pedal is not depressed.	0V

NOTE

NC: Indicates ON at all times. (For cruise control)
 NO: Indicates OFF at all times. (For stop light)

7. CHECKING THE INHIBITOR SWITCH CIRCUIT <A/T>

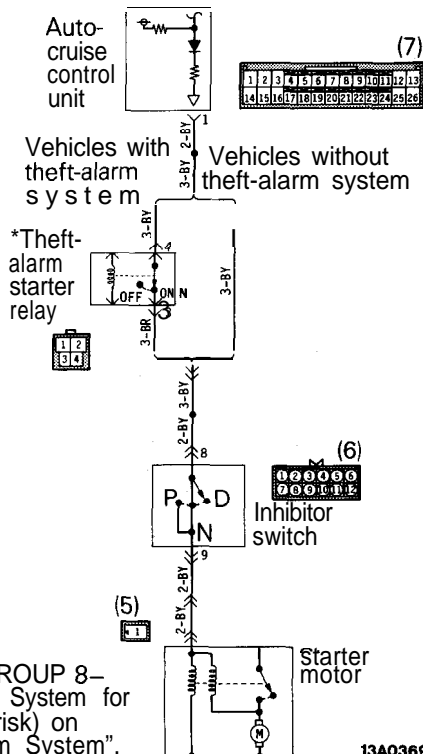

13A0369

NOTE
 Refer to GROUP 8—Theft-alarm System for the * (asterisk) on "Theft-alarm System".

Description of operation

The inhibitor switch also functions as the switch for the starter. If the selector lever is moved to the "N" position during constant-speed travel, current flows to the control unit, inhibitor switch, theft-alarm starter relay (vehicles with theft-alarm system), starter motor, and to ground; the cancel signal is therefore input to the control unit, thus canceling the constant-speed travel.

Troubleshooting hint

ECU terminal voltage

Terminal No.	Signal	Conditions	Terminal voltage
1	Inhibitor switch	At all times	System voltage

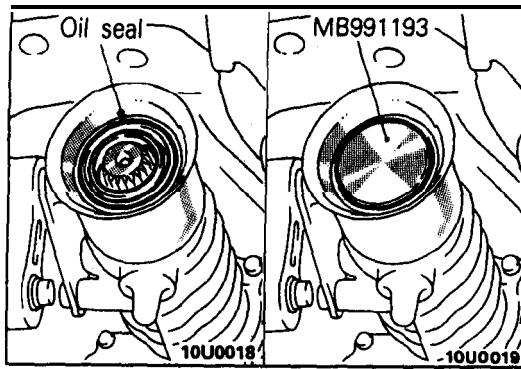

2. Do not lower rear end of the vehicle as the oil will flow out of the transfer.
3. Be cautious to avoid damage to the oil seal lip of the transfer.
4. Use the special tool provided as a cover to prevent the entry of foreign objects into the transfer.

INSPECTION

N16GCAH

- Check the sleeve yoke, center yoke and flange yoke for wear, damage or cracks.
- Check the propeller shaft yokes for wear, damage or cracks.
- Check the propeller shaft for bends, twisting or damage.
- Measure the propeller shaft runout with a dial indicator.

Limit:

Front propeller shaft	0.6 mm (.024 in.) or less
Center propeller shaft	0.6 mm (.024 in.) or less
Rear propeller shaft	0.6 mm (.024 in.) or less

NOTE

Set the V-blocks as much as possible to the end of the shaft. Measure deflection at the center of the shaft.

- Check the universal joints for smooth operation in all directions.
- Check the center bearing for smooth movement.
- Check the center bearing mounting rubber for damage or deterioration.

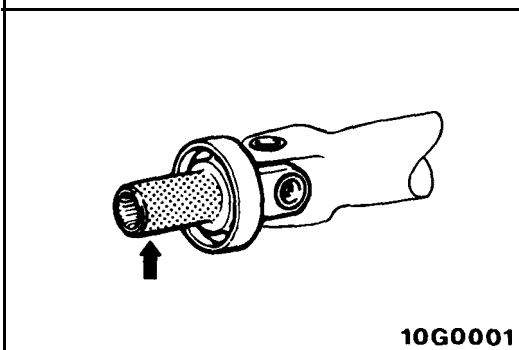
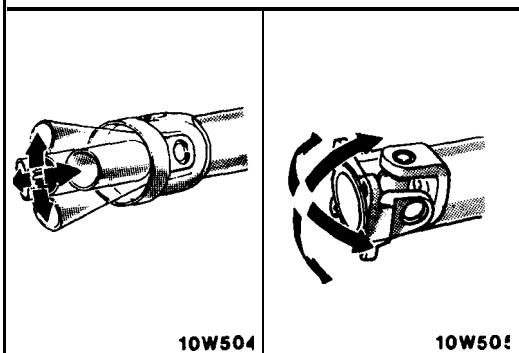
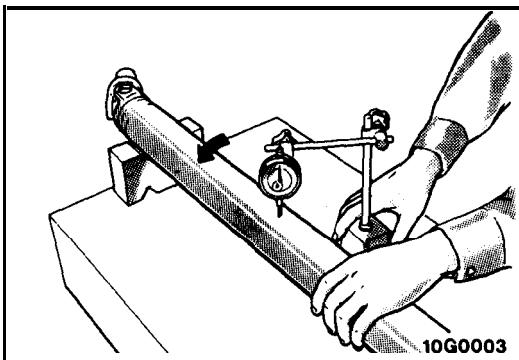

SERVICE POINTS OF INSTALLATION

N16GDA0

4. INSTALLATION OF PROPELLER SHAFT

- (1) Apply the specified gear oil to the sleeve yoke.

Specified oil: MOPAR Hypoid Gear Oil/API classification GL-4 or higher, SAE 75W-85W

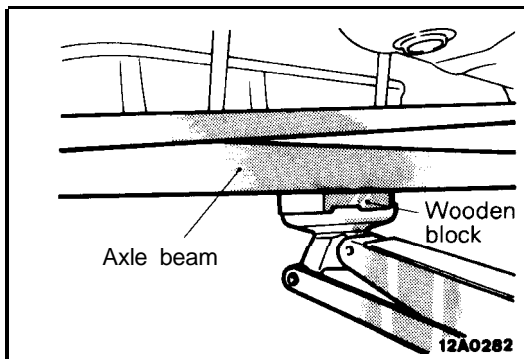
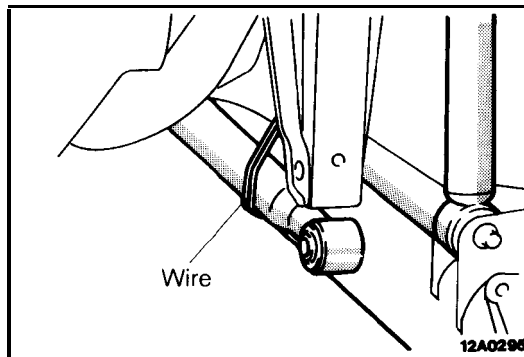

SERVICE POINTS OF REMOVAL

N17GBAR

1. REMOVAL OF REAR SPEED SENSOR <VEHICLES WITH ABS>

Refer to GROUP 5–Wheel Speed Sensor.

11. REMOVAL OF LATERAL ROD MOUNTING BOLT

- (1) Remove the lateral rod mounting bolt.
- (2) Secure and hold the lateral rod to the axle beam with wire, etc.

13. REMOVAL OF SHOCK ABSORBER UPPER MOUNTING NUTS/14. TRAILING ARM MOUNTING BOLTS/15. REAR SUSPENSION ASSEMBLY

- (1) Jack up the torsion axle and arm assembly in order to raise it slightly.

Caution

1. Always insert a wooden block between the jack receptacle and the axle beam and place the jack at the center of the axle beam.
2. Make sure that the jack does not contact the lateral rod.

- (2) Remove the shock absorber mounting nuts and trailing arm mounting bolts.
- (3) Lower the jack slowly, and then remove the rear suspension assembly.

INSPECTION

N17GCAL

- Check the trailing arm and axle beam for deformation or damage.
- Check the torsion bar for damage.
- Check the lateral rod for damage or deformation.
- Check the bushings for cracking, deterioration, or unusual wear.

BUSHING REPLACEMENT

N17GTAE

TRAILING ARM BUSHING

- (1) Drive out the trailing arm bushing as shown in the illustration.

Caution

The bearing within the special tool should be installed, as shown in the figure, at the race surface nut side of the bearing.

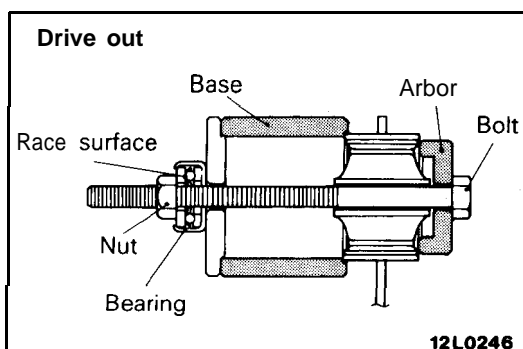

REAR SUSPENSION ASSEMBLY

REMOVAL AND INSTALLATION

N17GA-B

Pre-removal Operation

- Removal of Hole Cover
(Refer to GROUP 23–Trims.)

Post-installation Operation

- Check of Wheel Alignment
(Refer to P.17-20.)
- Check of Parking Brake Lever Stroke
(Refer to GROUP 5–Service Adjustment Procedures.)
- Installation of Hole Cover
(Refer to GROUP 23–Trims.)

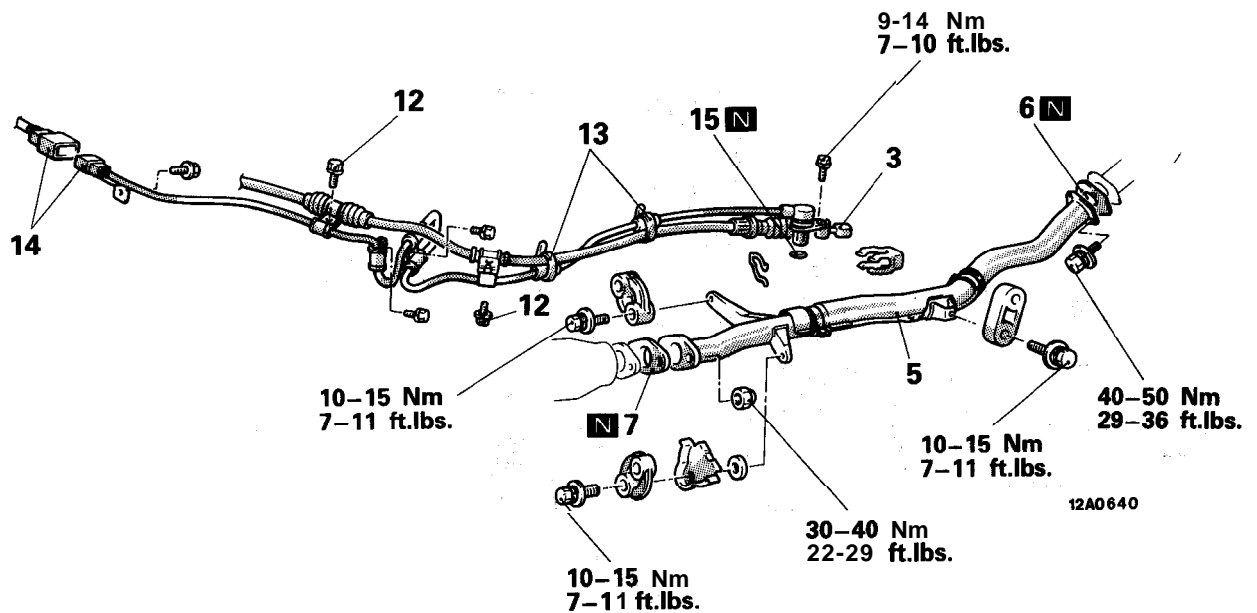

Removal steps

1. Shock absorber installation nut
2. Brake tube bracket installation bolt
- + 3. Parking brake cable end
- ◄► 4. Caliper assembly
5. Center exhaust pipe
6. Gasket
7. Gasket
- ◄► ● + 8. Propeller shaft installation bolt and nut

NOTE

- (1) Reverse the removal procedures to reinstall.
- (2) ◄►: Refer to "Service Points of Removal".
- (3) ● +: Refer to "Service Points of Installation".
- (4) N: Non-reusable parts

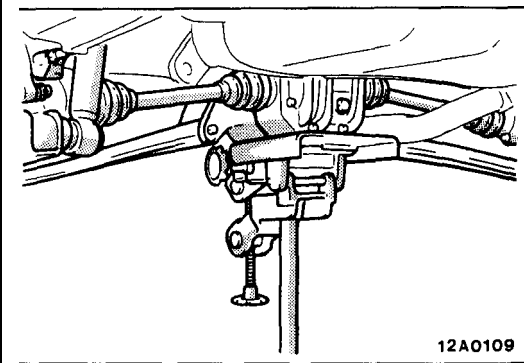
**SERVICE POINTS OF REMOVAL**

N17DAB

1. REMOVAL OF SELF LOCKING NUT/2. CROSSMEMBER BRACKET

- (1) Support the rear suspension assembly with a transaxle jack.
- (2) Remove the self locking nuts and crossmember brackets.

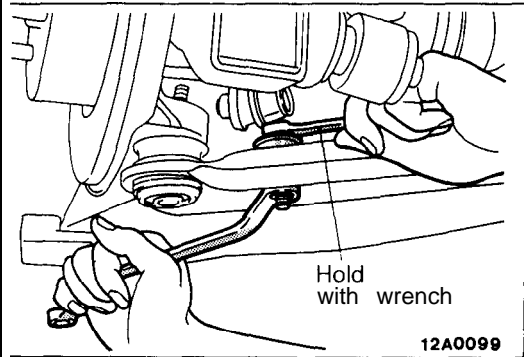
**6. REMOVAL OF SELF LOCKING NUT**

- Hold the stabilizer link with a wrench, then remove the self locking nut.

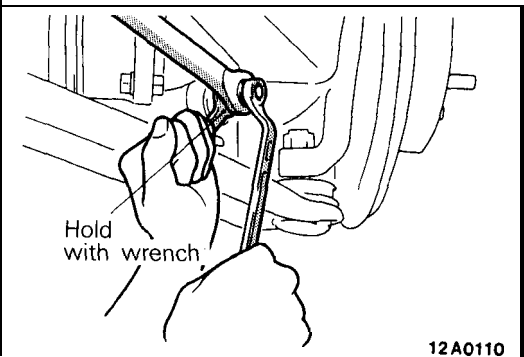
**10. REMOVAL OF SELF LOCKING NUT/ 11. STABILIZER LINK**

- (1) Hold the stabilizer links with a wrench and remove the self locking nut.
- (2) Remove the stabilizer link.

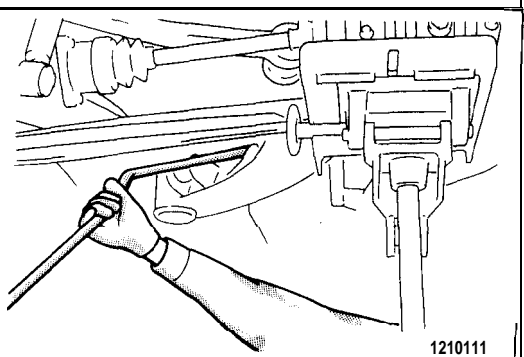
**14. REMOVAL OF STABILIZER BAR**

- (1) Lower the transaxle jack slightly, maintaining a gap between the rear suspension and the body.
- (2) Remove the stabilizer bar.

INSPECTION

N02TCAF

- Check the bushing for wear and deterioration.
- Check the stabilizer bar for deterioration or damage..
- Check the stabilizer link ball joint dust cover for cracks.
- Check all bolts for condition and straightness.

4. Disconnect the high-tension cable, and then while operating the starting motor intermittently, turn the steering wheel all the way to the left and right several times to drain all of the fluid.

Caution

Be careful not to position the high-tension cable near the carburetor or the delivery pipe.

5. Connect the return hoses securely, and then secure it with the clip.
6. Fill the oil reservoir with the specified fluid up to the lower position of the filter, and then bleed the air.

Specified fluid: MOPAR ATF PLUS (Automatic Transmission Fluid Type 7176)/Automatic transmission fluid "DEXRON" or "DEXRON II"

BLEEDING

N19FKAG

1. Jack up the front wheels and support them by using a floor stand.
2. Manually turn the oil pump pulley a few times.
3. Turn the steering wheel all the way to the left and right several times.
4. Disconnect the high-tension cable, and then, while operating the starting motor intermittently, turn the steering wheel all the way to the left and right several times (for 15 to 20 seconds).

Caution

1. During air bleeding, replenish the fluid supply so that the level never falls below the lower position of the filter.
2. If air bleeding is done while engine is running, the air will be broken up and absorbed into the fluid; be sure to do the bleeding only while cranking.
5. Connect the ignition cable, and then start the engine (idling).
6. Turn the steering wheel to the left and right until there are no air bubbles in the oil reservoir.
7. Confirm that the fluid is not milky, and that the level is up to the specified position on the level gauge.
8. Confirm that there is very little change in the fluid level when the steering wheel is turned left and right.
9. Check whether or not the change in the fluid level is within 5 mm (.2 in.) when the engine is stopped and when it is running.

Caution

1. If the change of the fluid level is 5 mm (.2 in.) or more, the air has not been completely bled from the system, and thus must be bled completely.
2. If the fluid level rises suddenly after the engine is stopped, the air has not been completely bled.
3. If air bleeding is not complete, there will be abnormal noises from the pump and the flow-control valve, and this condition could cause a lessening of the life of the pump, etc.

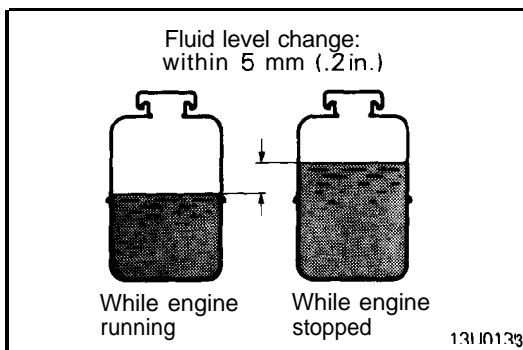

POWER STEERING GEAR BOX

REMOVAL AND INSTALLATION

Pre-removal Operation

- Draining of the Power Steering Fluid
- Removal of Transfer (Refer to GROUP 21 -Transfer.) <AWD>

Post-installation Operation

- Installation of Transfer (Refer to GROUP 21 -Transfer.) <AWD>
- Bleeding of the Power Steering Fluid Line (Refer to P.19-13.)
- Checking of Steering Wheel Position with Wheels Straight Ahead
- Adjustment of the Front Wheel Alignment (Refer to GROUP Z-Service Adjustment Procedures.)

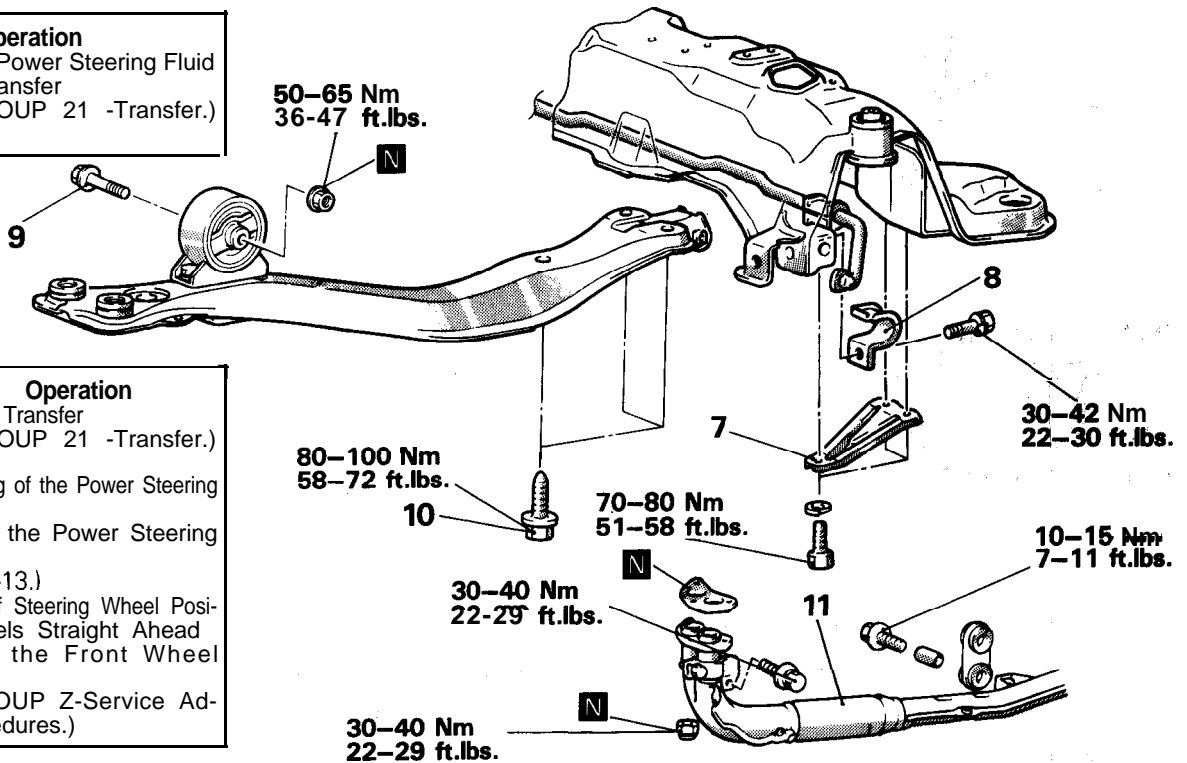

13A0276

Removal steps

1. Joint assembly and gear box connecting bolt
2. Connection for return tube
3. Connection for pressure hose
4. Cotter pin
5. Tie-rod end and knuckle connecting nuts
- ◆◆ 6. Tie-rod end
7. Stay
8. Stabilizer bar bracket
9. Front roll stopper mounting bolt
- ◆◆ 10. Center member rear mounting bolt
- ◆◆ 11. Front exhaust pipe <FWD>
- * ● + 12. Gear box assembly
- + 13. Mounting rubber

NOTE

- (1) Reverse the removal procedures to reinstall.
- (2) ◆◆: Refer to "Service Points of Removal".
- (3) ◆◆: Refer to "Service Points of Installation".
- (4) N: Non-reusable parts

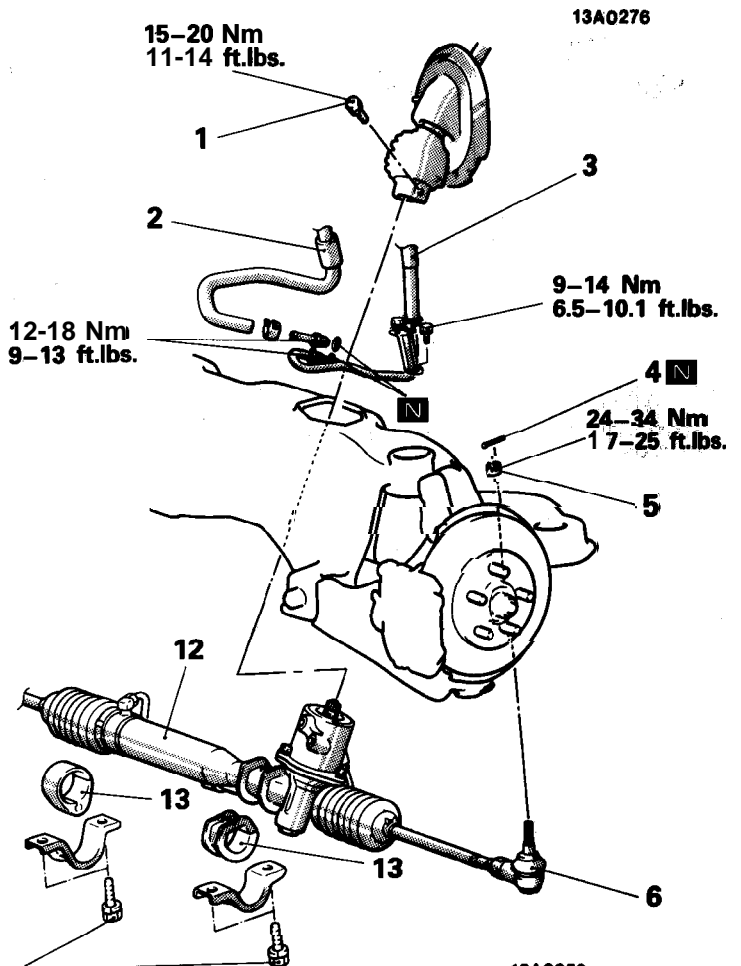

W-W Nm
43-58 ft.lbs.

13A0353

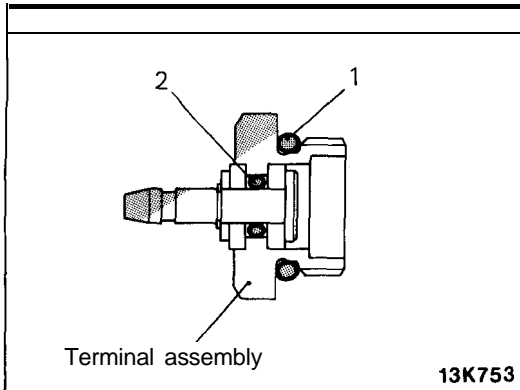

25./23. INSTALLATION OF O-RINGS

Apply specified fluid on O-rings to install.

Specified fluid: MOPAR ATF PLUS (Automatic Transmission Fluid Type 7176)/Automatic transmission fluid "DEXRON" or "DEXRON II"

No.	I.D. x Width mm (in.)	Identification color
1	13 x 1.9 (.51 x .0748)	Blue
2	3.8 x 1.9 (.15 x .0748)	—

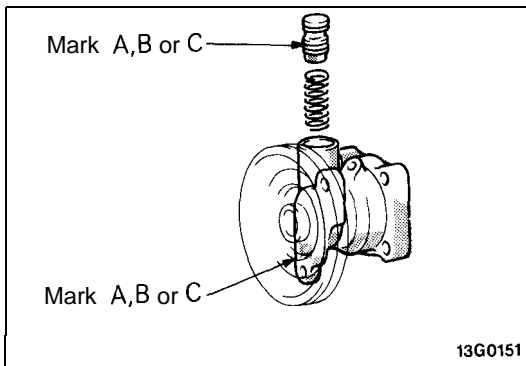

16. INSTALLATION OF FLOW CONTROL VALVE

- (1) If the flow control valve is to be replaced, install the flow control valve to the oil pump body corresponding with the body identification mark (A, B, C).
- (2) Apply the specified fluid to the outside of the flow control valve.

Specified fluid: MOPAR ATF PLUS (Automatic Transmission Fluid Type 7176)/Automatic transmission fluid "DEXRON" or "DEXRON II"

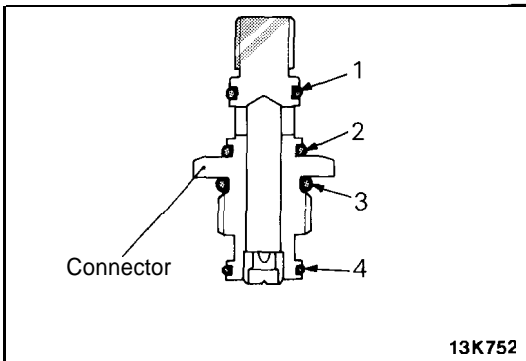

15. INSTALLATION OF O-RINGS

Apply specified fluid on O-rings to install.

Specified fluid: MOPAR ATF PLUS (Automatic Transmission Fluid Type 7176)/Automatic transmission fluid "DEXRON" or "DEXRON II"

No.	I.D. x Width mm (in.)	Identification color
1	11 x 1.9 (.43 x .0748)	Yellow
2	13 x 1.9 (.51 x .0748)	Blue
3	17.8 x 2.4 (.70 x .0945)	—
4	13.5 x 1.5 (.53 x .0590)	Red

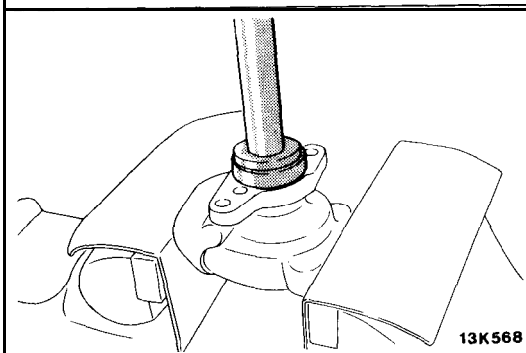

13. INSTALLATION OF OIL SEAL

Drive the oil seal into the pump body.

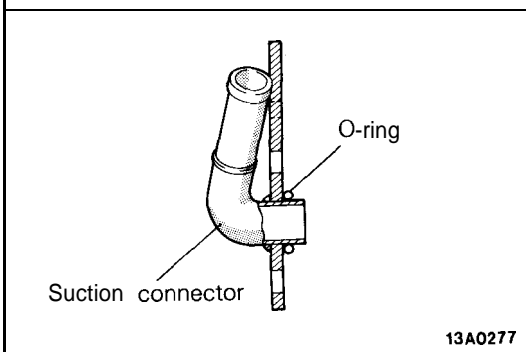





12. INSTALLATION OF O-RING

Apply specified fluid on O-ring to install.

Specified fluid: MOPAR ATF PLUS (Automatic Transmission Fluid Type 7176)/Automatic transmission fluid "DEXRON" or "DEXRON II"

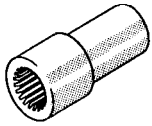
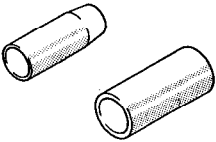
I.D. x Width mm (in.)	Identification color
17.8 x 2.4 (.70 x .0945)	—

21-12 MANUAL TRANSAXLE <FWD> – Special Tools/Troubleshooting

Tool	Number	Name	Use
	MD998802	Input shaft holder	Installation and removal of input shaft and intermediate shaft lock nut
	MD998808	Snap ring installer	Installation of input shaft rear snap ring
	MD998812	Installer cap	Use with MD998818, MD998822
	MD998819	Installer adapter	Installation of differential case bearing
	MD998822	Installer adapter	Installation of differential case bearing

TROUBLESHOOTING

N21EAABa

Symptom	Probable cause	Remedy
Vibration, noise	a. Loose or damaged transaxle and engine mounts	a. Tighten or replace mounts
	b. Inadequate shaft end play	b. Correct end play
	c. Worn or damaged gears	c. Replace gears
	d. Use of inadequate grade of oil	d. Replace with specified oil
	e. Low oil level	e. Replenish
	f. Inadequate engine idle speed	f. Adjust idle speed
Oil leakage	a. Broken or damaged, oil seal or O-ring	a. Replace oil seal or O-ring
Hard shift	a. Faulty control cable	a. Replace control cable
	b. Poor contact or wear of synchronizer ring and gear cone	b. Correct or replace
	c. Weakened synchronizer spring	c. Replace synchronizer spring
	d. Use of inadequate grade of oil	d. Replace with specified oil
Jumps out of gear	a. Worn gear shift fork or broken poppet spring	a. Replace shift fork or poppet spring
	b. Synchronizer hub to sleeve spline clearance too large	b. Replace synchronizer hub and sleeve

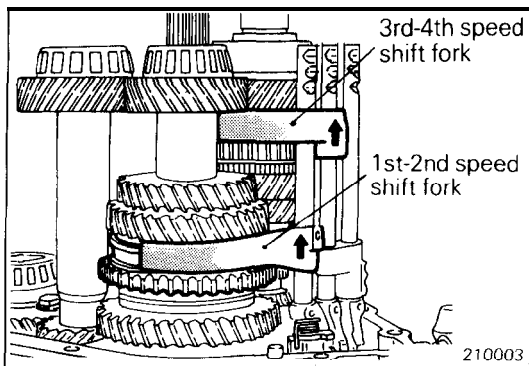

47./48. REMOVAL OF SHIFT RAILS AND FORKS'

- (1) Shift the 1st-2nd speed shift fork to the 2nd speed.
- (2) Shift the 3rd-4th speed shift fork to the 4th speed.

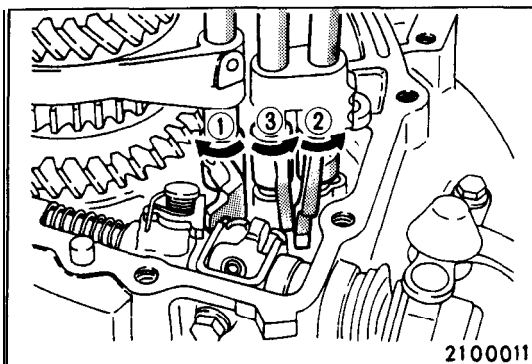

- (3) Rotate the the shift controls in the direction of the arrow in numerical order. Remove the shift lugs from the control finger and interlock plate.
- (4) Raise each of the shift rails upward and remove them from the clutch housing.
- (5) Remove the all shift rails and forks.

52. REMOVAL OF INTERMEDIATE GEAR ASSEMBLY

Lift up the input shaft assembly and remove the intermediate gear assembly.

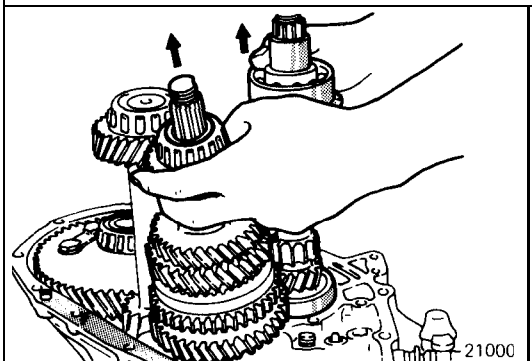

INSPECTION

N21MOAA

BACKUP LIGHT SWITCH

Operate the backup light switch to check continuity with a circuit tester. If without continuity, replace the switch.

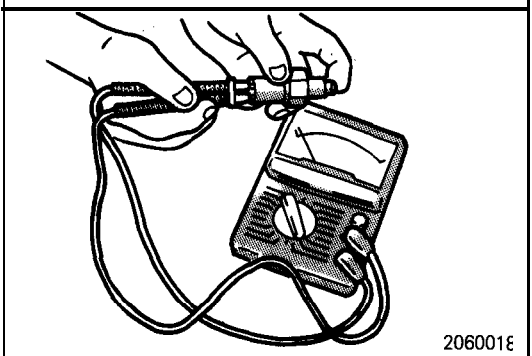

SERVICE POINTS OF REASSEMBLY

N21MGAU

61. INSTALLATION OF OIL SEAL

Install the drive shaft oil seal using the special tool.

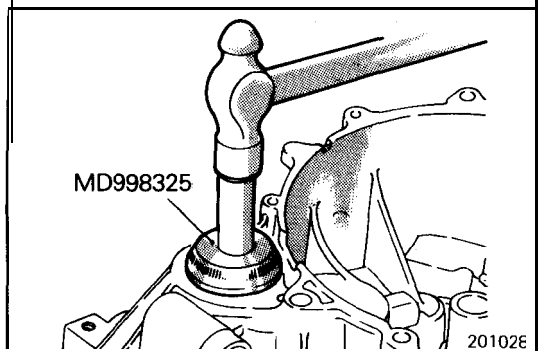

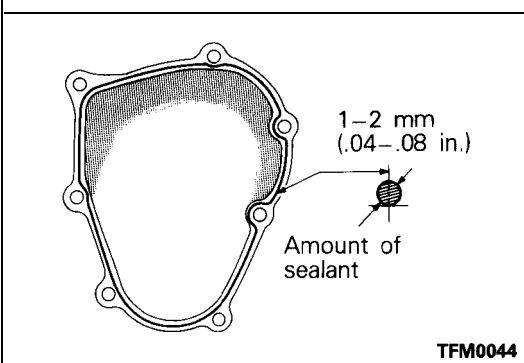
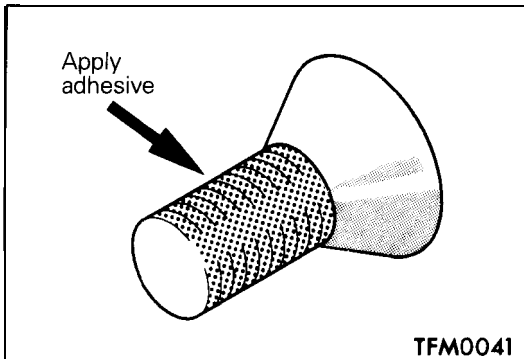

4. INSTALLATION OF SCREW BOLTS

Apply specified adhesive to screw bolts mounting portion.
Specified adhesive: **MOPAR Part No.4318031**
or **MOPAR Part No. 4318032**
or 'equivalent

2. APPLICATION OF SEALANT TO THE REAR COVER

Apply specified sealant to the rear cover.
Specified sealant: **MITSUBISHI Genuine Part No. MD997740**
or equivalent

Caution
Squeeze out sealant from the tube uniformly without excess or discontinuity.

5TH SPEED SYNCHRONIZER ASSEMBLY

N21MHAK

DISASSEMBLY AND REASSEMBLY

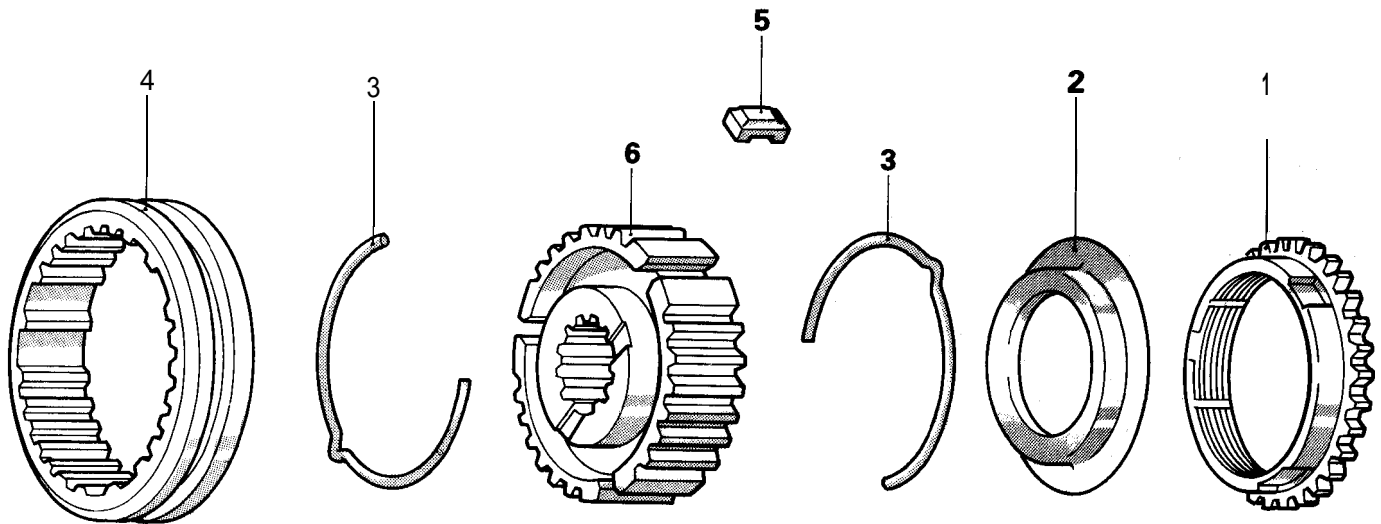

Disassembly steps

1. Reverse brake ring (F5M22-2, F5M33)
2. Stop plate (F5M22-1)
- ◆◆ 3. Synchronizer spring
4. Synchronizer sleeve
- ◆◆ 5. Synchronizer key
- ◆◆ 6. Synchronizer hub

TFM0055

NOTE

- (1) Reverse the disassembly procedures to reassemble.
- (2) ◆◆ : Refer to "Service Points of Reassembly".

CLICK HERE TO **DOWNLOAD** THE COMPLETE MANUAL

- Thank you very much for reading the preview of the manual.
- You can download the complete manual from: www.heydownloads.com by clicking the link below



- Please note: If there is no response to CLICKING the link, please download this PDF first and then click on it.

CLICK HERE TO **DOWNLOAD** THE COMPLETE MANUAL

**10. REMOVAL OF 1ST-2ND SPEED SYNCHRONIZER HUB/
12. 2ND SPEED GEAR**

Remove the 1 st-2nd speed synchronizer assembly and 2nd speed gear together using the special tool as illustrated.

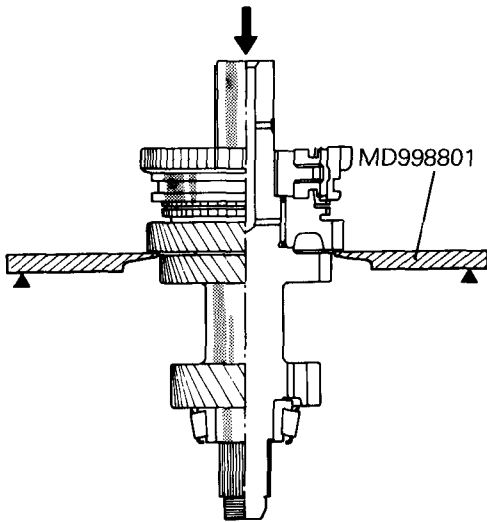

201063

14. REMOVAL OF TAPER ROLLER BEARING

Use the special tool as illustrated.

Caution

1. Do not reuse the bearing removed from the shaft.
2. Replace the inner and outer races of the taper roller bearing as a set.

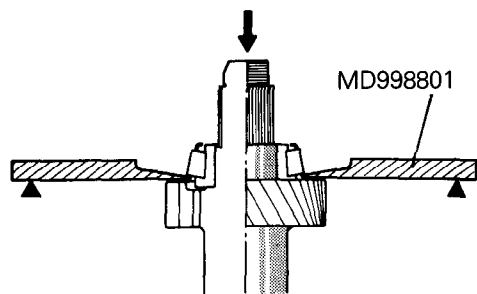

210022

INSPECTION

INTERMEDIATE GEAR

- Check the outer surface of the intermediate gear where the needle bearing is mounted for damage, abnormal wear and seizure [portion Ⓐ.]
- Check the splines for damage and wear.

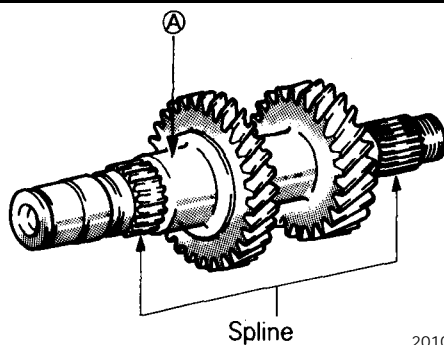

201065

NEEDLE BEARING

- Combine the needle bearing with the shaft or bearing sleeve and gear and check that it rotates smoothly without abnormal noise or play.
- Check the needle bearing cage for deformation.

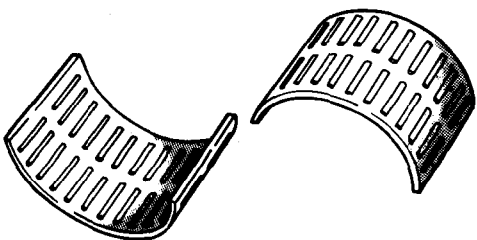

201051

Part name	Thickness mm (in.)	Identification symbol	Part No.
Spacer (For preload adjustment of center differential case)	1.58 (.0622)	58	MD718527
	1.61 (.0634)	61	MD71 8528
	1.64 (.0646)	64	MD718529
	1.67 (.0657)	67	MD71 8530
	1.70 (.0669)	70	MD71 8531
	1.73 (.0681)	73	MD721 959
	1.76 (.0693)	76	MD721 960
	1.79 (.0705)	79	MD721961
Spacer (For adjustment of center differential pinion backlash-Front side)	2.09-2.16 (.0823-.0850)	0	MD730350
	2.17-2.24 (.0854-.0882)	9	MD730349
	2.25-2.32 (.0886-.0913)	8	MD730348
	2.33-2.42 (.0917-.0953)	7	MD730347
	2.43-2.50 (.0957-.0984)	6	MD730346
	2.51-2.58 (.0988-.1016)	5	MD730345
	2.59-2.66 (.1020-.1047)	4	MD730344
	2.67-2.74 (.1051-.1079)	3	MD730343
2.75-2.82 (.1083-.1110)	2	MD730342	
Spacer (For adjustment of center differential pinion backlash- Rear side)	0.59-0.66 (.0232-.0260)	74	MD724974
	0.67-0.74 (.0264-.0291)	50	MD724950
	0.75-0.82 (.0295-.0323)	80	MD720680
	0.83-0.92 (.0327-.0362)	79	MD720679
	0.93-1.00 (.0366-.0394)	78	MD720678
	1.01-1.08 (.0398-.0425)	76	MD720676
	1.09-1.16 (.0429-.0457)	77	MD720677
	1.17-1.24 (.0461-.0488)	49	MD724949
Spacer (For adjustment of front differential case end play)	0.56 (.0220)	56	MD727658
	0.65 (.0256)	65	MD727659
	0.74 (.0291)	74	MD727660
	0.83 (.0327)	83	MD720937
	0.92 (.0362)	92	MD720940
	1.01 (.0398)	01	MD720943
	1.10 (.0433)	J	MD71 0454
	1.19 (.0469)	L	MD71 0456
1.28 (.0504)	N	MD710458	
1.37 (.0539)	P	MD71 0460	
Spacer (For adjustment of front differential pinion backlash)	0.75-0.82 (.0295-.0323)	-	MA1 80862
	0.83-0.92 (.0327-.0362)	-	MA1 80861
	0.93-1.00 (.0366-.0394)	-	MA1 80860
	1.01-1.08 (.0398-.0425)	-	MA1 80875
	1.09-1.16 (.0429-.0457)	-	MA1 80876

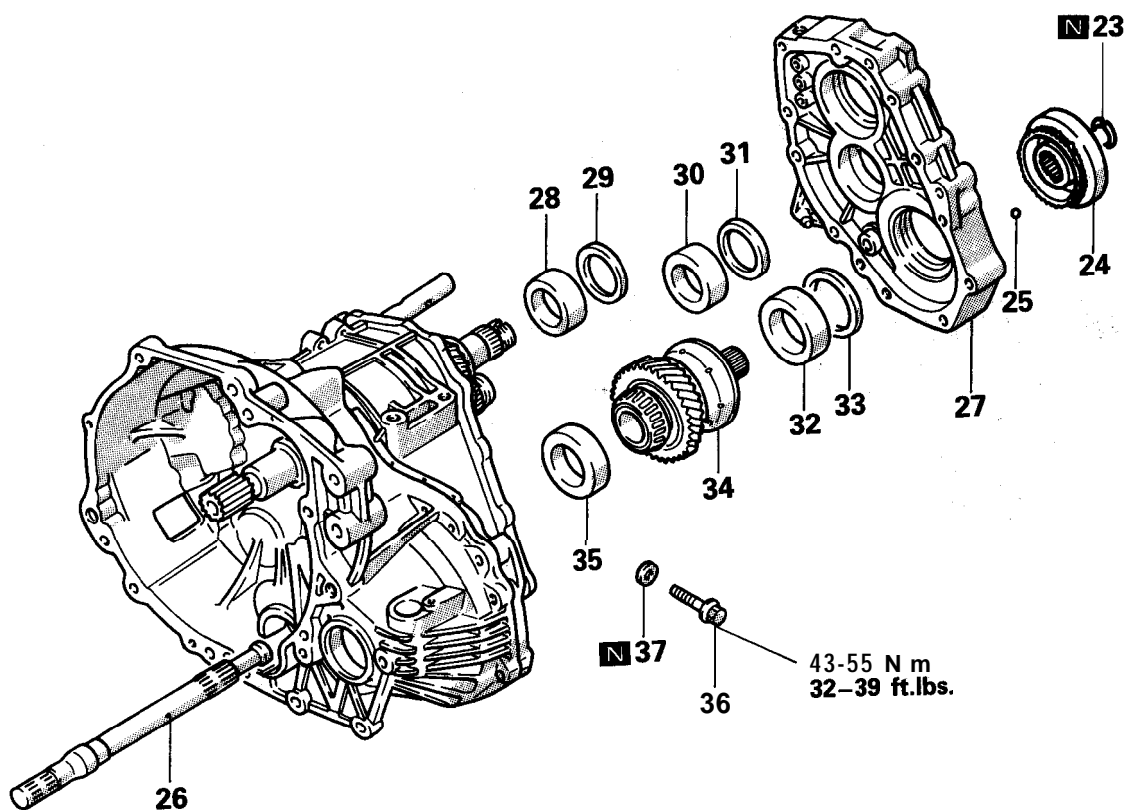

Disassembly steps

- ◆◆ 23. Snap ring
- ◀▶ 24. Viscous coupling
 - 4 25. Steel ball
- 26. Center shaft
- 27. Transaxle case adapter
- 28. Outer race
- * 29. Spacer
- 30. Outer race
- 4 31. Spacer
- 32. Outer race
- * 33. Spacer
- 34. Center differential
- ◀▶ 35. Outer race
- + 36. Reverse idler gear shaft bolt
- 37. Gasket

NOTE

- (1) Reverse the disassembly procedures to reassemble.
- (2) ◀▶: Refer to "Service Points of Disassembly".
- (3) ● +: Refer to "Service Points of Reassembly".
- (4) N: Non-reusable parts.

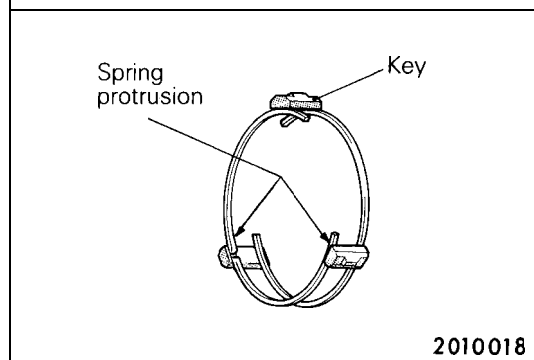
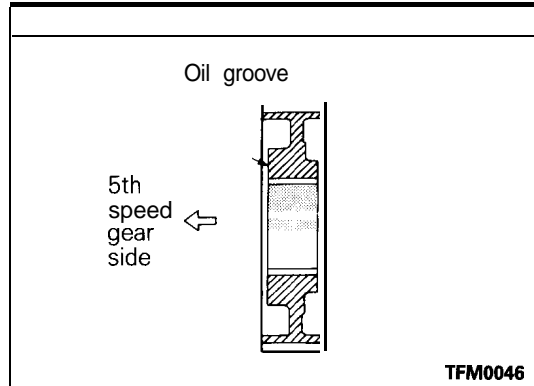

SERVICE POINTS FOR REASSEMBLY

5. INSTALLATION OF SYNCHRONIZER HUB./4. SYNCHRONIZER KEY

Install the synchronizer hub, and key in the directions as shown.

2. INSTALLATION OF SYNCHRONIZER SPRINGS

Install the synchronizer springs so that its protrusion fits into the synchronizer key. Make sure that the protrusions in the front and rear springs do not fit over the same key.

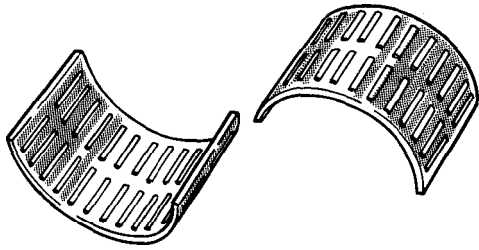

201051

NEEDLE BEARING

- Mate the needle bearing with the shaft or bearing sleeve and gear, and check to see if rotation is smooth with no binding, noise, or play.
- Check the needle bearing cage for possible deformation.

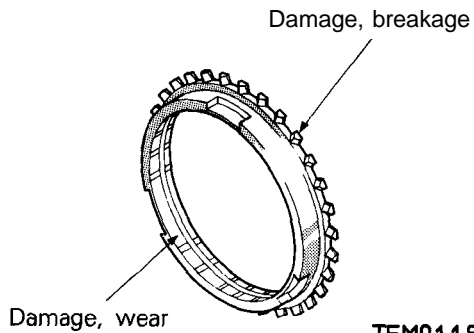

TFM0119

SYNCHRONIZER RING

- Check the clutch gear teeth for damage and breakage.
- Check the cone inside paper lining for damage, wear or peeling.

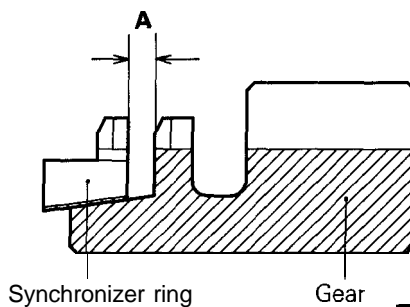

TFM0117

- Force the synchronizer ring toward the clutch gear and check clearance "A". Replace if the clearance is below the limit.

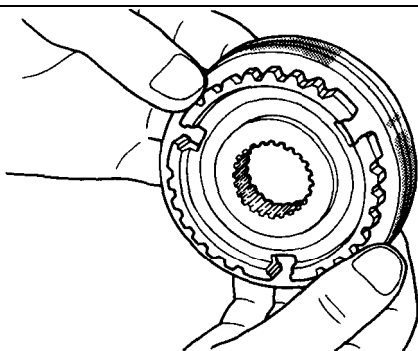
Limit: 0.5 mm (.020 in.)

201044

SYNCHRONIZER SLEEVE AND HUB

- Mate the synchronizer sleeve with the hub and check to see if they slide smoothly.
- Check to see if the sleeve is free from damage at its inside front and rear ends.
- Check the hub front and rear end faces (in contact with each speed gear) for wear.

Caution

When replacement is necessary, replace the synchronizer hub and sleeve as a set.

SYNCHRONIZER KEY AND SPRING

- Check the synchronizer key center protrusion for wear.
- Check the spring for proper tension, possible deformation and breakage.

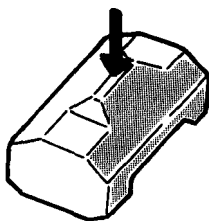

201045

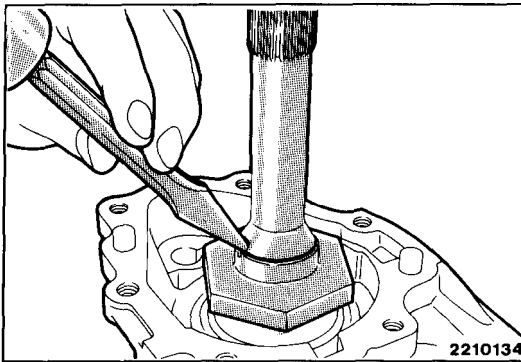

SERVICE POINTS OF DISASSEMBLY

1. REMOVAL OF LOCK NUT

(1) Unstake the lock nut.

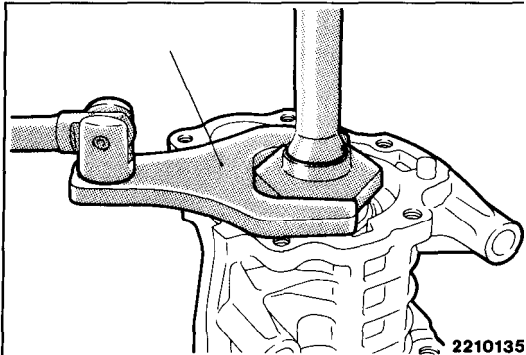

(2) Remove the driven bevel gear's lock nut by using the special tool.

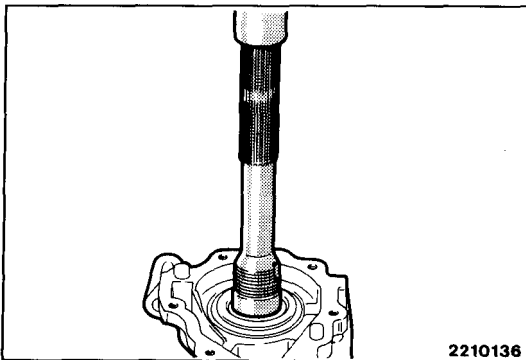

2. REMOVAL OF DRIVEN BEVEL GEAR ASSEMBLY

Using a press, remove the driven bevel gear assembly.

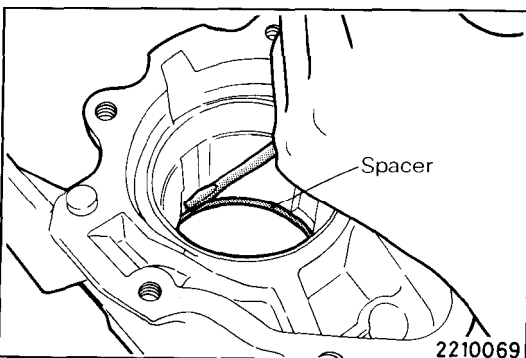

6./7. REMOVAL OF OUTER RACE

Apply a screwdriver to the outer race and tap it to remove the outer race.

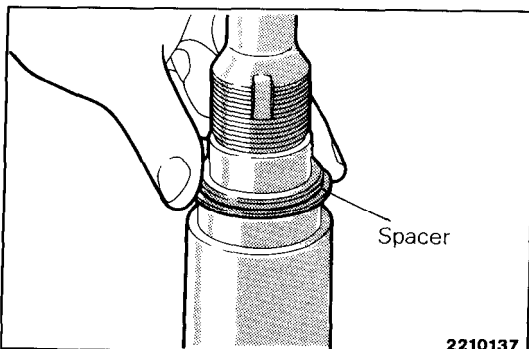

SERVICE POINTS OF REASSEMBLY

4. INSTALLATION OF SPACER

Install the spacer which has been used so far.

<F4A22 – Drive-Fourth>

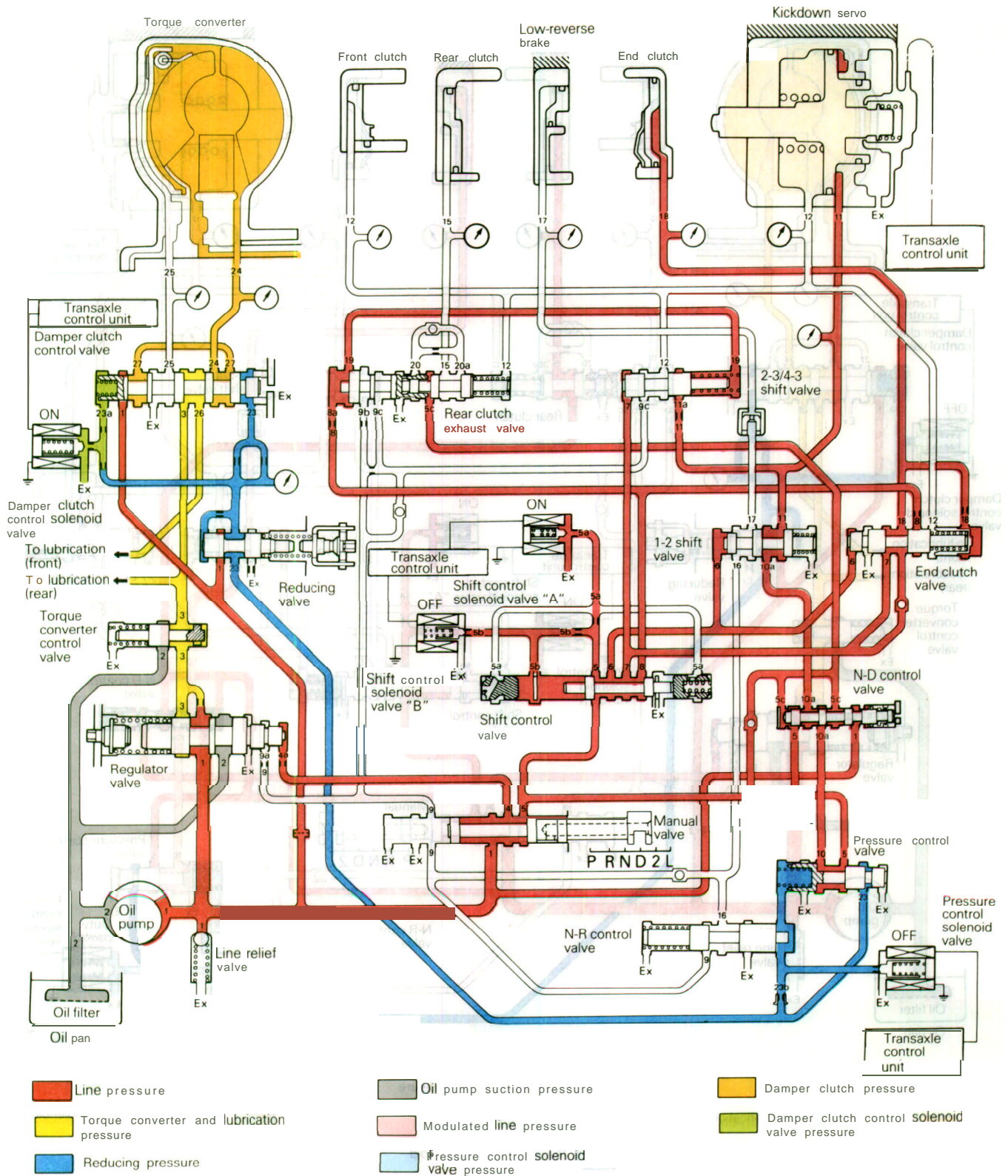

Drive (Fourth)

Part name	Thickness mm (in.)	Identification	mark Part No.
Spacer (F4A33-W4A33) [for adjustment of transfer driven gear (center differential case) preload]	0.74 (.0291)	74	MD728802
	0.77 (.0303)	77	MD728803
	0.80 (.0315)	80	MD728804
	0.83 (.0327)	83	MD728805
	0.86 (.0339)	86	MD728806
	0.89 (.0350)	89	MD728807
	0.92 (.0362)	92	MD728808
	0.95 (.0374)	95	MD728809
	0.98 (.0386)	98	MD728810
	1.01 (.0398)	01	MD728811
	1.04 (.0409)	04	MD728812
	1.07 (.0421)	07	MD728813
	1.10 (.0433)	10	MD728814
	1.13 (.0445)	13	MD728815
	1.16 (.0457)	16	MD728816
	1.19 (.0469)	19	MD728817
	1.22 (.0480)	22	MD728818
1.25 (.0492)	25	MD728819	
1.28 (.0504)	28	MD728820	
1.31 (.0516)	31	MD728821	
Pressure plate (play)adjustment of low/reverse brake end	5.9 (.232)	A	MD731 736
	6.0 (.236)	0	MD731737
	6.1 (.240)	1	MD731 738
	6.2 (.244)	2	MD731 739
	6.3 (.248)	3	MD731 740
	6.4 (.252)	4	MD731 588
	6.5 (.256)	5	MD731 741
	6.6 (.260)	6	MD731 742
	6.7 (.264)	7	MD731 743
	6.8 (.268)	8	MD731 744
6.9 (.272)	9	MD731745	
Spacer (F4A33-W4A33) (for adjustment of differential case preload) *:W4A33 only	0.83 (.0327)	83	MD720937
	0.86 (.0339)	86	MD720938
	0.89 (.0350)	89	MD720939
	0.92 (.0362)	92	MD720940
	0.95 (.0374)	95	MD720941
	0.98 (.0386)	98	MD720942
	1.01* (.0398)	01	MD720943
	1.04 (.0409)	04	MD720944
	1.07 (.0421)	07	MD720945
	1.10* (.0433)	J	MD710454
	1.13 (.0445)	D	MD700270
	1.16 (.0457)	K	MD710455
	1.19* (.0469)	L	MD710456
	1.22 (.0480)	G	MD700271
	1.25 (.0492)	M	MD710457
1.28" (.0504)	N	MD710458	
1.31 (.0516)	E	MD706574	

	Transaxle malfunction of shift-shock (after start-off)															Abnormal noise, other				
	Won't shift from 2nd to 3rd	Won't shift to 4th	Overdrive control switch doesn't function	Doesn't shift according to shift pattern (shifting is possible)	Improper start-off (starts off from 2nd, etc.)	Excessive creeping or idling vibration	Excessive vibration-shock when shift 1-2 or 3-4	Excessive vibration-shock when shift 2-3 or 4-3	Excessive vibration-shock during upshift	Excessive vibration-shock during D-2 downshift	Sudden engine rpm increase during upshift	Sudden engine rpm increase during 3-2 shift, excessive vibration	Excessive vibration-shock only when cold	Excessive vibration-shock (other than already described)	Damper clutch won't function	Abnormal vibration in high-load region in low gear (approx. 1 Hz)	Abnormal noise from converter housing together with engine rpm	Mechanical noise (clatter noise) from converter housing	Abnormal noise inside transaxle case	3rd gear is held
1						X														
2					X		X	X	X				X	X		X				
3		X			X															X
4					X										X	X				
5												X					X			
6																				
7																		X		
8																				
9																	X			
10	X	X								X	X									X
11																				X
12										⊗	⊗		X							X
13	X			X	X		X	X	X	X	X	X	X	X	X					X
14	X							X	X	X	X									X
15																				X
16							X			X	X									X
17							X			X	X		X							
18									X											X
19																				X
20		⊗					X			X										X
21		X			X															X
22				⊗			X	X	⊗	X	X		X	X	X					
23							X	X	X	X	X		X	X	X					X
24				X										X	X					X
25							X				X									X
26																				X
27							X	X	X	X	X		X	X						
28																				X
29																				X
30	X	X								X	X									X
31														X						
32															X					X
33		X	X																	
34					X	X								X	X					
35													X	X	X					
36																				X
37				X																X
38	X	X	X	X	X	X	X	X	X	X	X	X	X	X	X	X	X	X	X	X

PSCV = Pressure control solenoid valve
 DCCSV = Damper clutch control solenoid valve

9. Damper clutch control solenoid valve (DCCSV)
1.8L, 2.0L DOHC Non-Turbo Engine

Solenoid valve connector terminals



- 1: PCSV
- 2: DCCSV
- 3: SCSV-A
- 4: SCSV-B

1750338

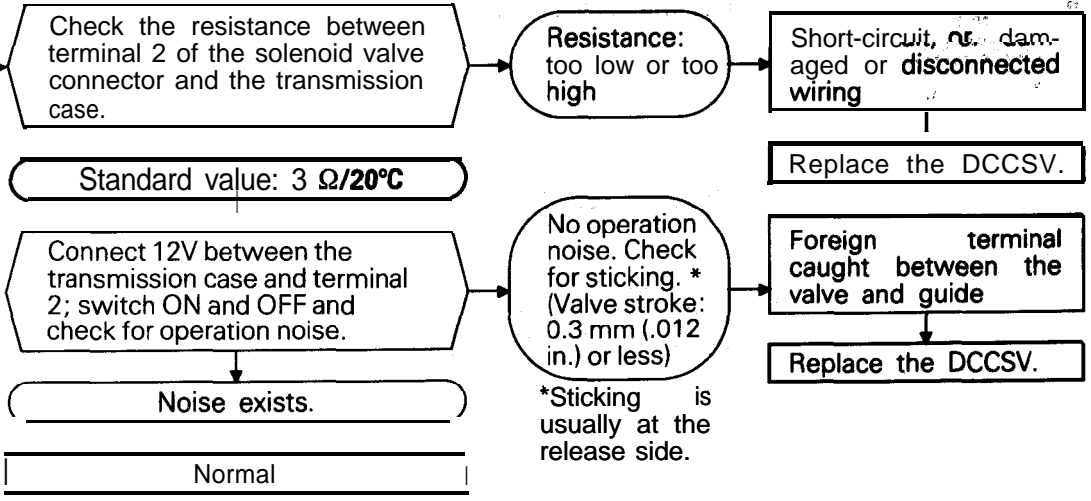

10. Accelerator switch

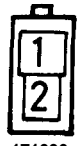

171096

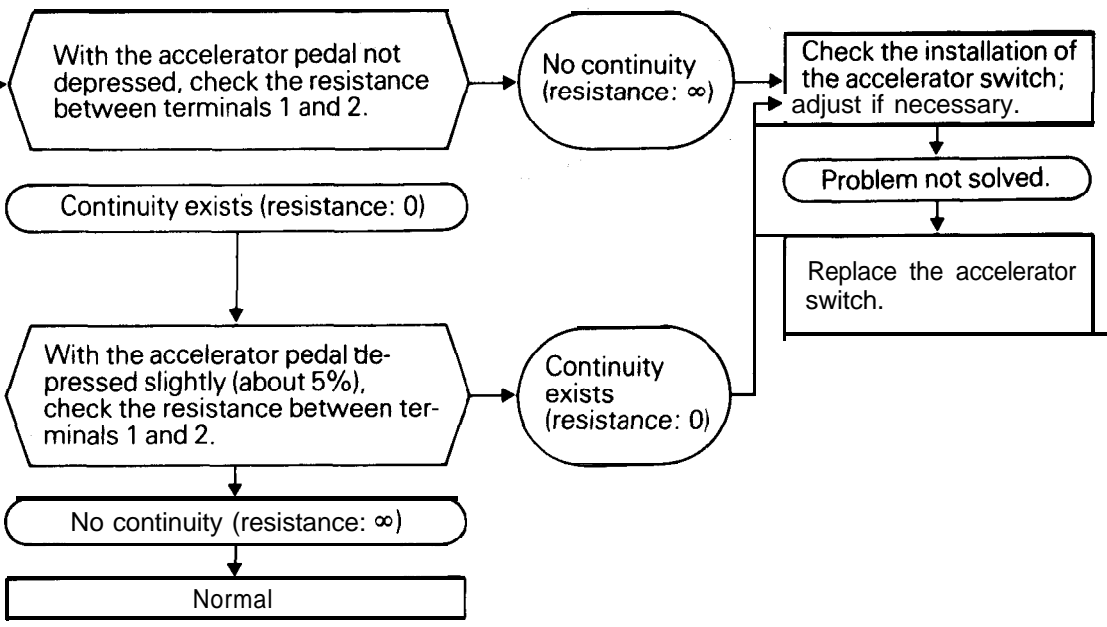

E.L.C. 4-SPEED AUTOMATIC TRANSAXLE CONTROL COMPONENTS LAYOUT

Name	Symbol	Name	Symbol
Diagnosis connector	F	Pulse generator B	A
Engine control unit	I	Solenoid valves	C
Oil temperature sensor	D	Throttle position sensor	B
Power (PWR)/Economy (ECO) select switch	G	Transaxle control unit	H
Pulse generator A	A	Vehicle-speed sensor	E

NOTE

1. The "Name" column is arranged in alphabetical order.
2. Refer to GROUP 14—On vehicle inspection of MPI components for installation position of **B** throttle position sensor.

1.8L Engine

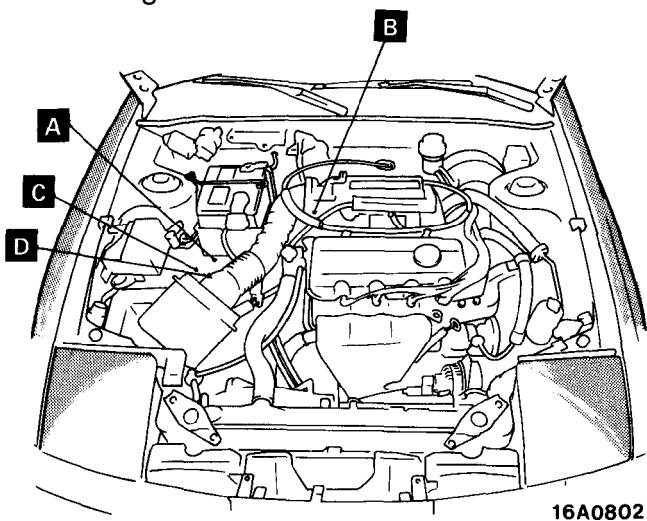

2.0L DOHC Engine

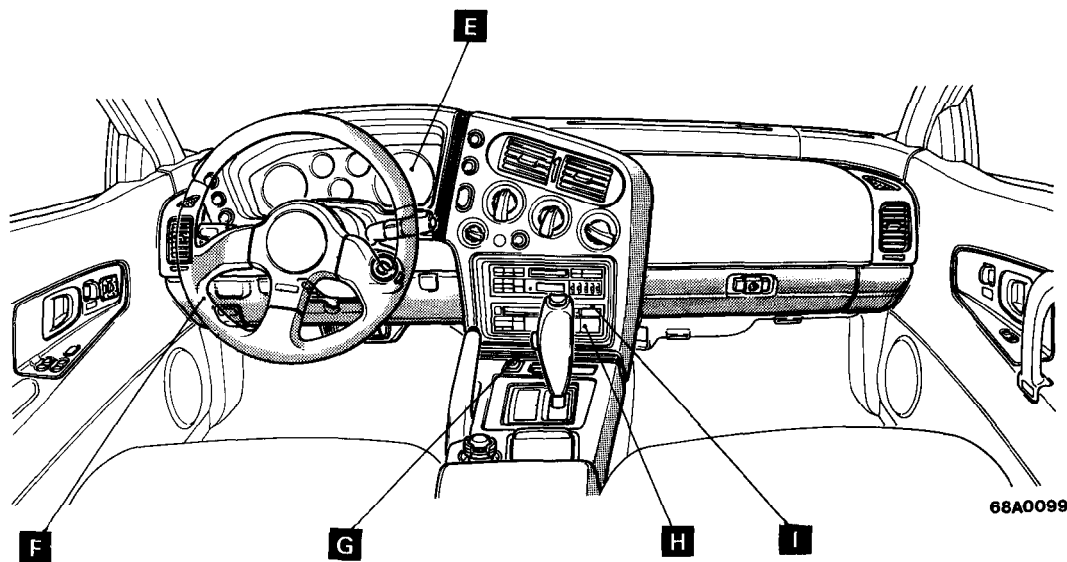
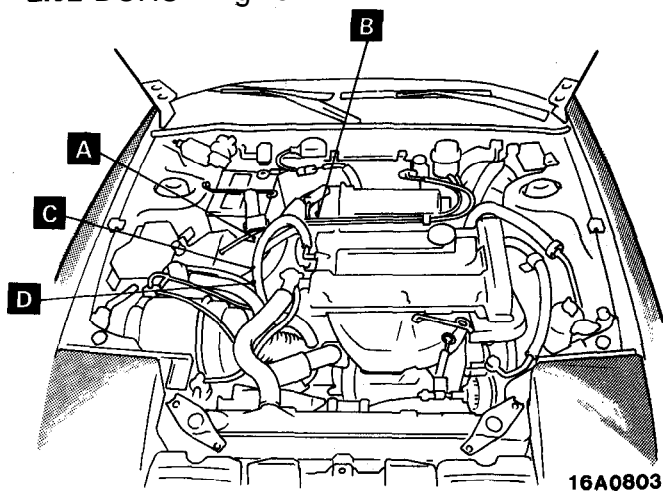

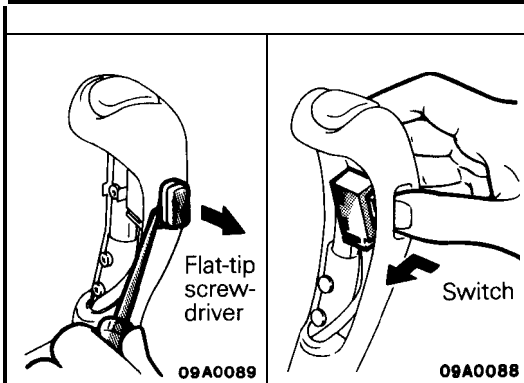

4. REMOVAL OF OVERDRIVE CONTROL SWITCH BUTTON/5. OVERDRIVE CONTROL SWITCH

- (1) Using the flat-tip screwdriver, remove the overdrive control switch button.
- (2) Pressing the switch, remove the overdrive control switch.

INSPECTION

N210GAD

- Check the detent plate for wear.
- Check the bushing for wear or damage.
- Check the spring for damage or deterioration.

SERVICE POINTS OF REASSEMBLY

N210HAM

18. APPLICATION OF GREASE TO LOCK CAM

Apply a coating of multipurpose grease to the sliding part of the bushing.

Grease: MOPAR Multi-mileage Lubricant Part No. 2525035 or equivalent

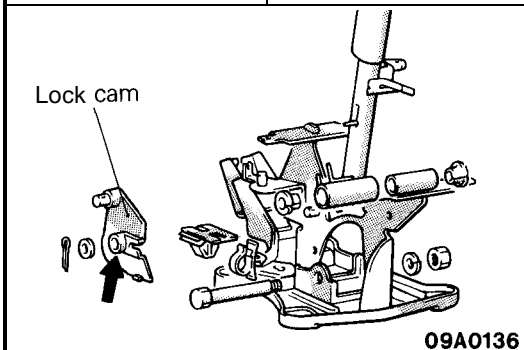

15. APPLICATION OF GREASE TO BUSHING

Apply a coating of multipurpose grease to the sliding part of the bushing.

Grease: MOPAR Multi-mileage Lubricant Part No. 2525035 or equivalent

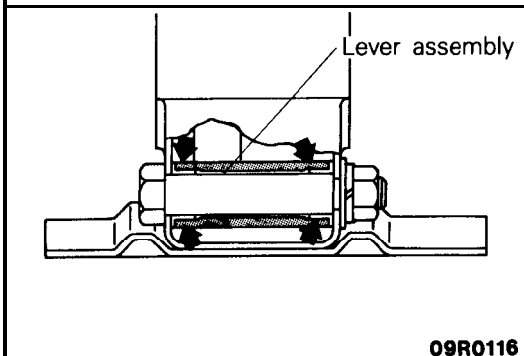

13. INSTALLATION OF SLEEVE

- (1) Place the shift lever in the "N" position, and then turn the sleeve so that the clearance between the sleeve and the lever assembly end is within the standard value.

Standard value (A): 15.2-15.9 mm (.598-.625 in.)

- (2) Apply a coating of multipurpose grease to the surface of the sleeve.

Grease: MOPAR Multi-mileage Lubricant Part No. 2525035 or equivalent

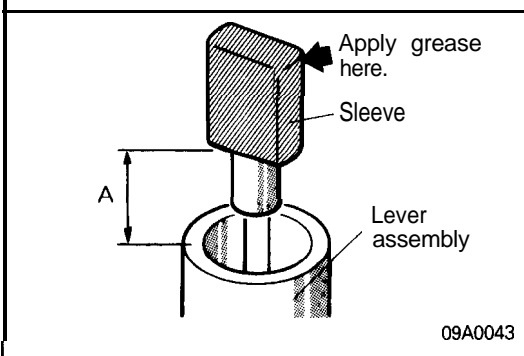

8. APPLICATION OF GREASE TO SPRING/7. PUSHBUTTON

Apply multipurpose grease at the places shown in the figure.

Grease: MOPAR Multi-mileage Lubricant Part No. 2525035 or equivalent

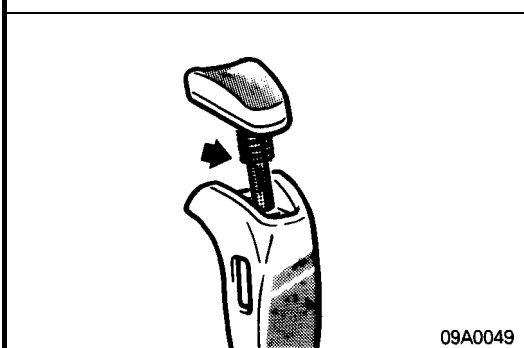

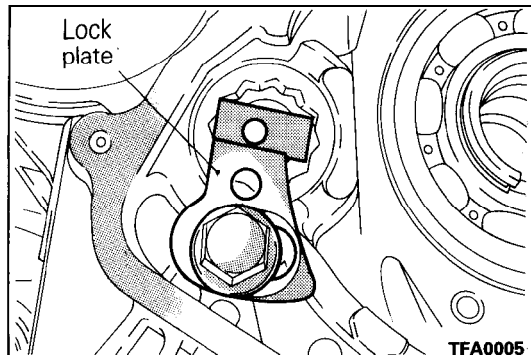

38. Remove idler shaft lock plate.

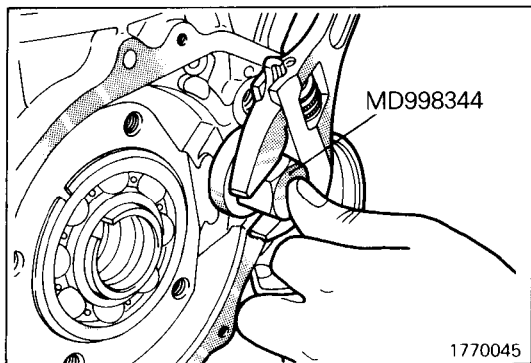

39. Loosen transfer idler shaft with special tool.

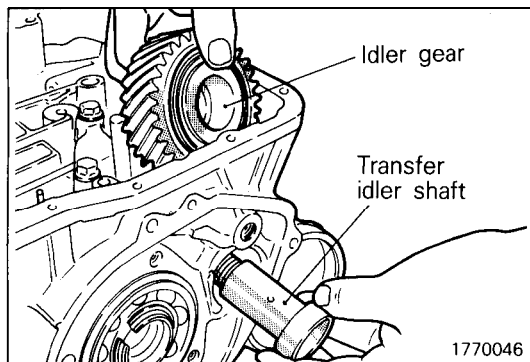

40. Pull out transfer idler shaft. Remove transfer idle gear bearing inner races (2 pieces) from inside of case.

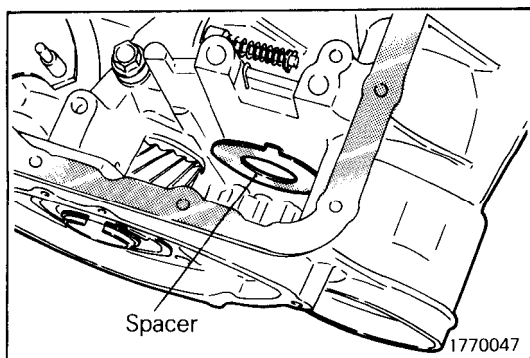

41. Remove the spacer.

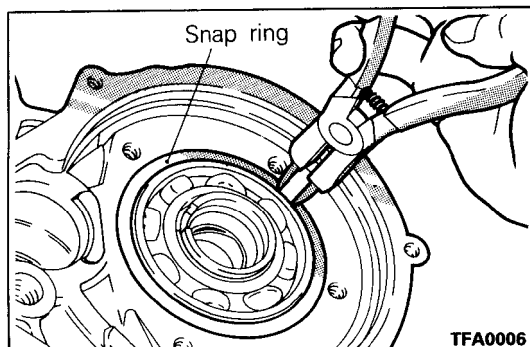

42. Remove snap ring from bearing.

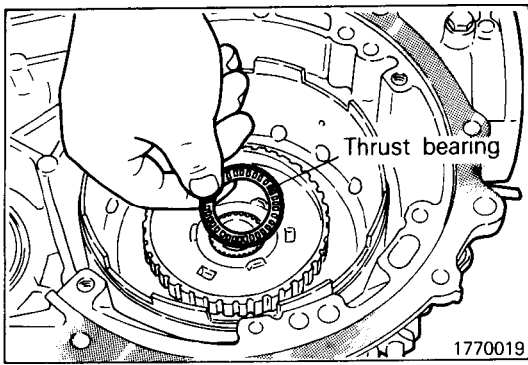

48. Attach thrust bearing #6 onto the hub with petrolatum.

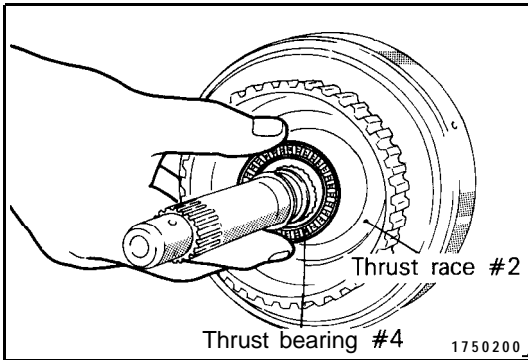

49. Apply a coating of petrolatum to thrust washer #2 and thrust bearing #4, and then attach to the rear clutch assembly.

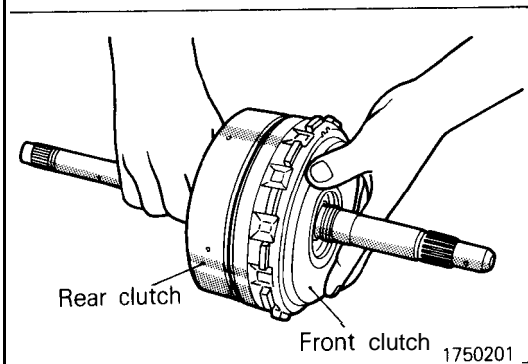

50. Combine the rear clutch assembly and the front clutch assembly.

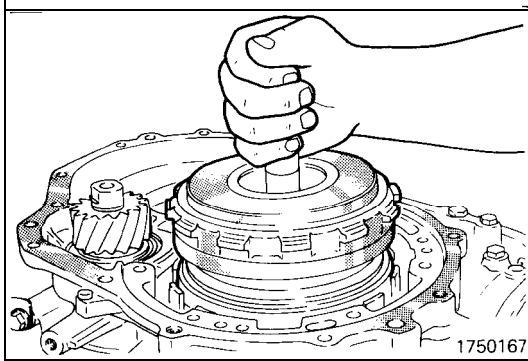

51. Install the clutch assembly.

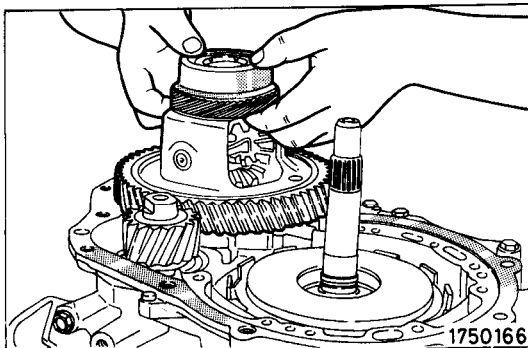

52. Install the differential assembly.

21-282 AUTOMATIC TRANSAXLE – Transaxle Assembly <F4A33-W4A33>

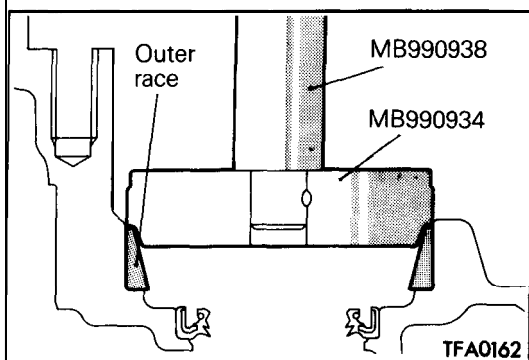

- Using the special tool, press-fit the outer race in the transaxle case.

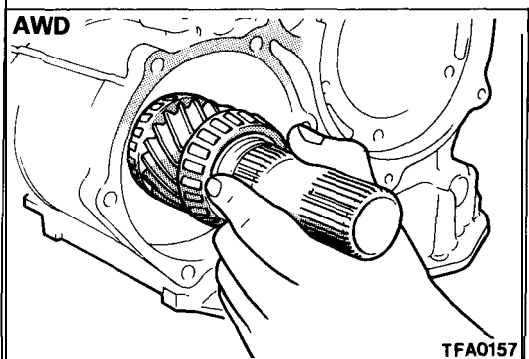

- Install the front output shaft assembly <AWD only>.

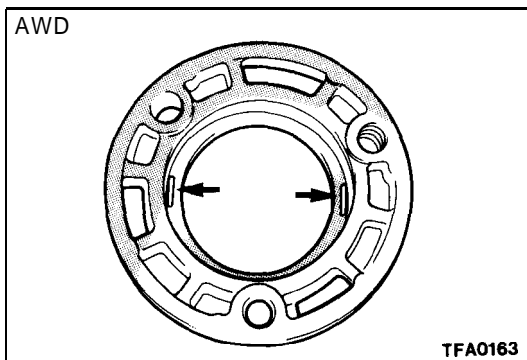

- Position the solder approx. 10 mm (.40 in.) long by 1.6 mm (.06 in.) in diameter in the front bearing retainer in the position shown in the figure and then install the outer race <AWD only>.

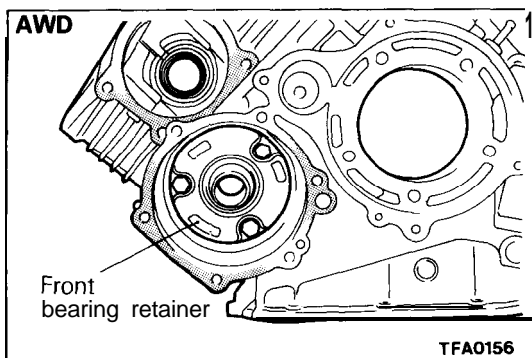

- Install the front bearing retainer and tighten the bolt with the specified torque <AWD only>.

Front bearing retainer mounting bolts:
43-55 Nm (32-39 ft.lbs.)

- Loosen the bolts and remove the front bearing retainer <AWD only>.
- Remove the outer race from the front bearing retainer and remove the solder. If the solder does not break, perform the work in steps 5–8 with large diameter solder. Measure the thickness of the crushed solder with a micrometer and select a spacer with the correct thickness so the pre-load reaches the standard value <AWD only>.

Standard value: 0.055–0.115 mm (.002–.005 in.)

- Install the spacer selected in the previous step and the outer race in the front bearing retainer <AWD only>.
- First install the front bearing retainer and apply sealant to the bolts and then tighten with the specified torque <AWD only>.

Specified sealant: 3M Stud Locking Part No.4170 or equivalent

Front bearing retainer mounting bolts:
43-55 Nm (32-39 ft.lbs.)

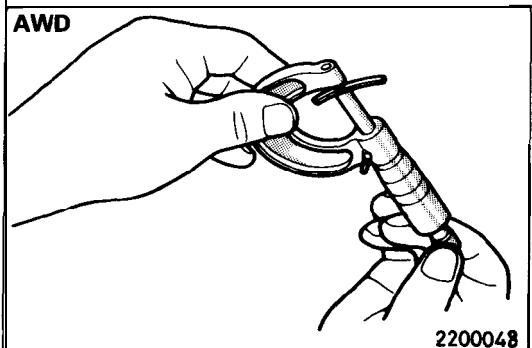

AUTOMATIC TRANSAXLE – Transaxle Assembly <F4A33-W4A33> 21-297

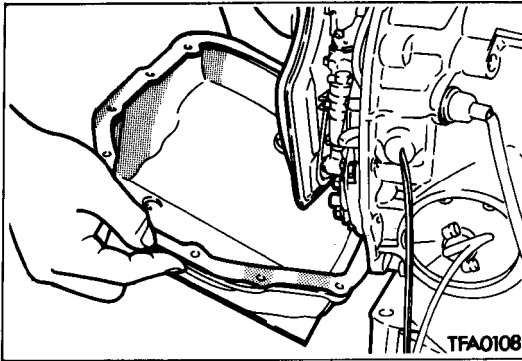

83. Install the magnet in the oil pan and then install the oil pan.
Oil pan mounting bolts: 10–12 Nm (7.5-8.5 ft.lbs.)

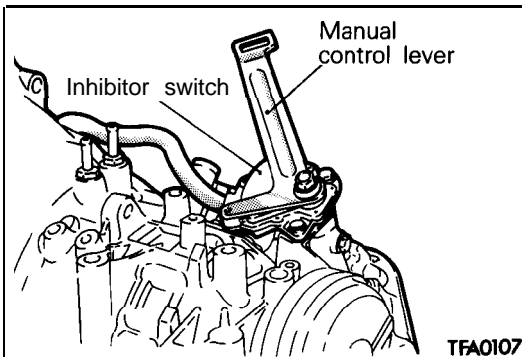

84. Install the inhibitor switch and manual control lever.
Inhibitor switch mounting bolts: 10–12 Nm (7.5-8.5 ft.lbs.)
Manual control lever mounting bolts: 17-21 Nm (13-15 ft.lbs.)

85. Install the speedometer gear assembly.
Speedometer gear locking plate mounting bolts: 4-6 Nm (3-4 ft.lbs.)
Pulse generator mounting bolts: 10–12 Nm (7.5-8.5 ft.lbs.)

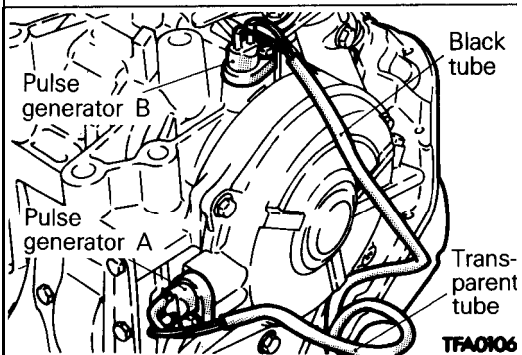

86. Install pulse generator A and B.
Caution
Install pulse generator A (with transparent tube) to the end clutch side and pulse generator B (with black tube) to the output gear side.

87. Install the oil filler tube and insert the level gauge.
Oil filler tube mounting bolts: 20–27 Nm (15-19 ft.lbs.)

88. Install the brackets.
Transaxle mounting bracket bolts: 60–80 Nm (44–57 ft.lbs.)

89. Adjust the kickdown servo.
90. Install the kickdown servo switch and fix the snap ring.

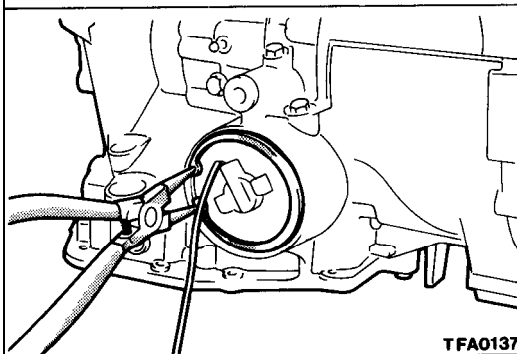

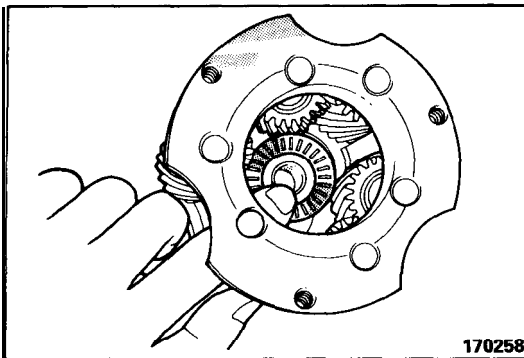

170258

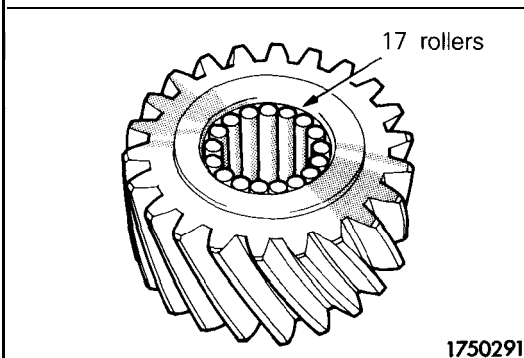

1750291

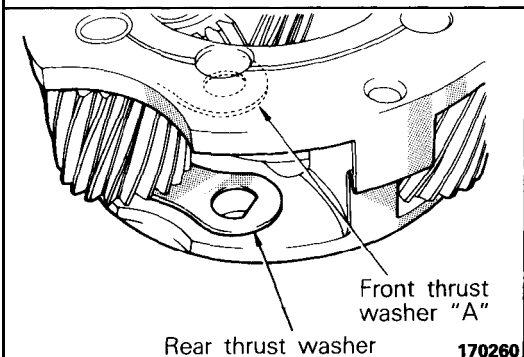

170260

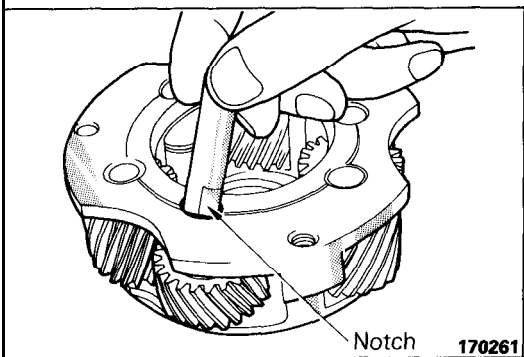

170261

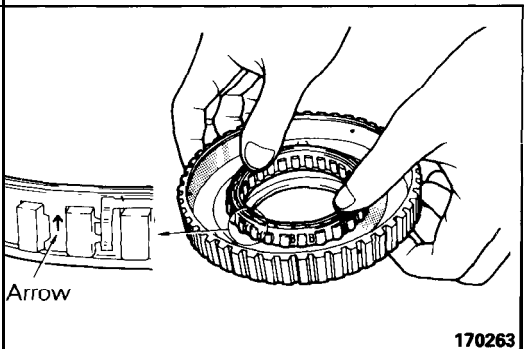

170263

SERVICE POINTS OF REASSEMBLY

12. INSTALLATION OF THRUST BEARING

- (1) Install a thrust bearing on the carrier. Make sure that it fits correctly in the spot faced portion of the carrier.

- (2) Apply vaseline unsparingly to the inside surface of the short pinion and attach the 17 rollers on the surface.

- (3) Line up the holes of the rear thrust washer and front thrust washer "A" with the shaft hole of the carrier.
- (4) Install the short pinion, spacer bushing and front thrust washer and align the holes. Use care not to allow the rollers to get out of position.

- (5) Insert the pinion shaft. Make sure that the flattened end of pinion shaft is correctly fitted in the hole of the rear thrust plate when the pinion shafts is inserted.

5. INSTALLATION OF ONE-WAY CLUTCH

Push the one-way clutch into the outer race. Make sure that arrow on the outside circumference of cage is directed upward as shown in the illustration when the one-way clutch is pushed in.

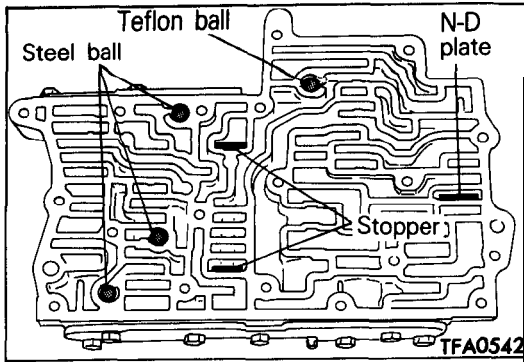

SERVICE POINTS OF REASSEMBLY

**42./33. LOCATION OF STOPPER PLATES/20. N-D PLATE/
19. TEFLON BALL/18. STEEL BALL**

Install the stopper plates, N-D plate, teflon ball and steel ball in the upper valve body in the positions shown in the figure.

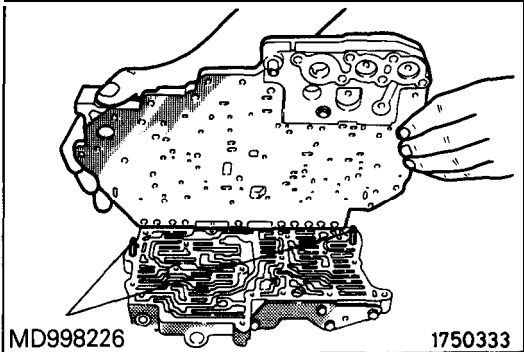

17. INSTALLATION OF UPPER VALVE BODY SUB ASSEMBLY

Install the special tool, then, after securing the upper separating plate and the intermediate plate by the eight installation bolts, remove the special tool.

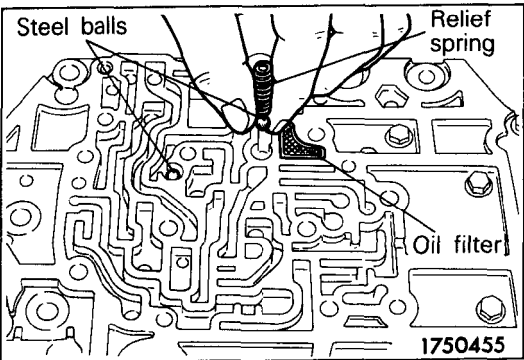

**16. INSTALLATION OF OIL FILTER/15. S T E E L B A L L/
14. RELIEF SPRING**

Install, to the intermediate plate, the oil filter, the two steel balls, and the spring.

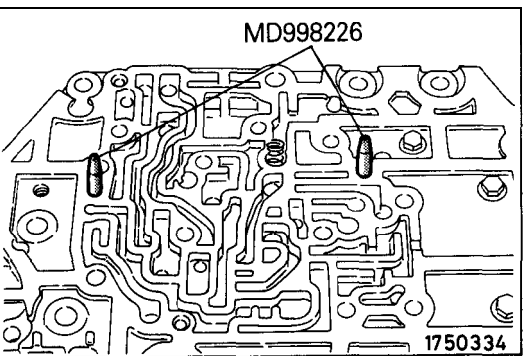

10. INSTALLATION OF LOWER VALVE BODY SUB ASSEMBLY

(1) Install the special tool to the intermediate plate.

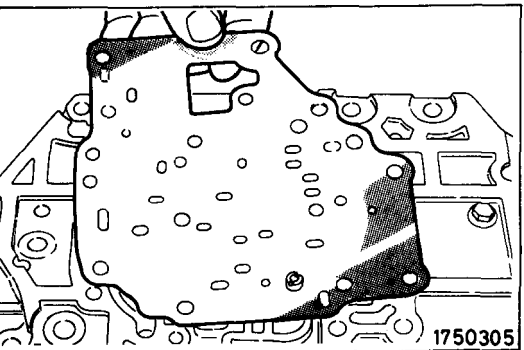

(2) Install the separating plate.

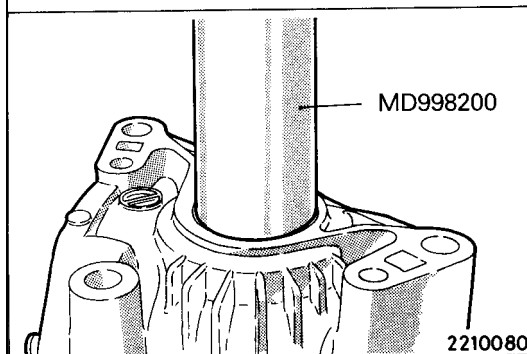
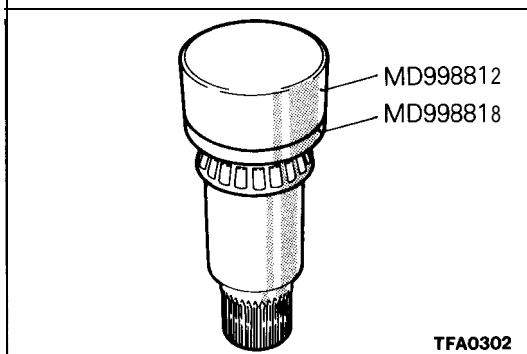
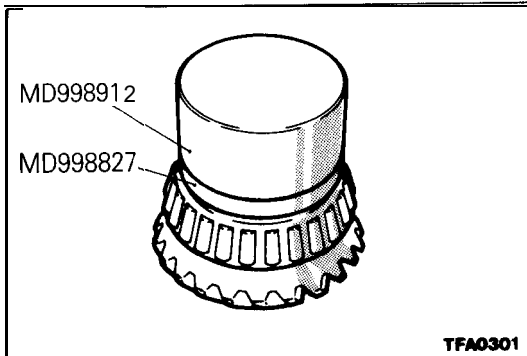
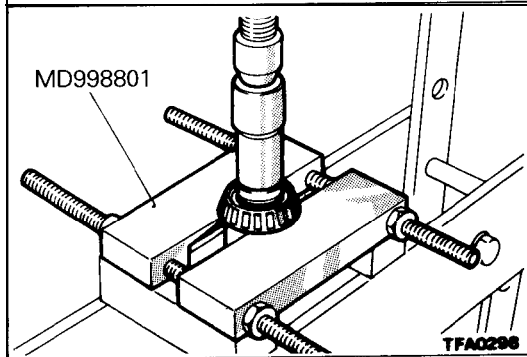
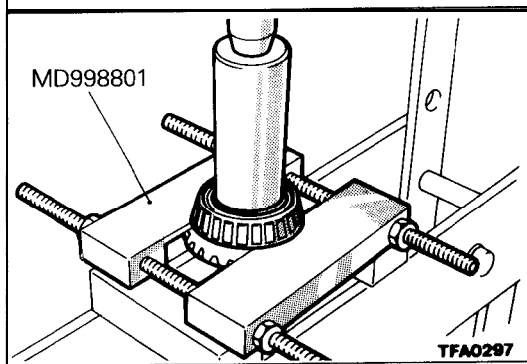

SERVICE POINTS OF DISASSEMBLY

11./12. REMOVAL OF TAPER ROLLER BEARINGS

Using the special tool, remove the taper roller bearing.

SERVICE POINTS OF REASSEMBLY

12./1 1. INSTALLATION OF TAPER ROLLER BEARINGS

Using the special tool, install the taper roller bearing.

8. INSTALLATION OF OIL SEAL

Using the special tool, install the oil seal.

SUNROOF

Symptom	Probable cause	Remedy
Water leaks	Dust accumulated in drainage of housing assembly	Keep off dust from inside of drain hose
	Clogged drain hose	Blow air into drain hose to remove dust
	Broken or dislocated drain hose, failed or cracked clip	Check hose installation and flange contact
	Worn roof lid weatherstrip	Replace
	Excessive roof lid-to-body clearance and improperly fitted weatherstrip	Adjust
Wind noise	Loose or deformed deflector	Retighten or replace

Step	Check method		Judgement		Cause	Remedy
	Operation	Check object	Normal	Malfunction		
Warning light						
1	Unplug the warning light connector Ignition switch: ON	Terminal voltage of warning light harness side connector (1-Ground)	System voltage	0 V	Open harness wire or disconnected connector between junction block and combination meter	Repair the harness or plug in the connector correctly
2	Connect the warning light connector. Unplug the connector from the control unit. Ignition switch: ON	Terminal voltage of control unit harness side connector (1 -Ground)	System voltage	0 V	Open harness wire or disconnected connector between combination meter and control unit	Repair the harness or plug in the connector correctly
					Warning light bulb blown or in poor contact	Replace or correctly install the warning light
Key reminder switch						
1	Disconnect the key reminder switch connector.	Terminal voltage of key reminder switch harness side connector (1 -Ground, 3-Ground)	System voltage	0 V	Open harness wire or disconnected connector between junction block and key reminder switch	Repair the harness or plug in the connector correctly
2	Plug the key reminder switch connector. Unplug the connector from the control unit Remove the key from the ignition switch.	Terminal voltage of control unit harness side connector (13-Ground, 12-Ground)	13-Ground: System voltage	0 v	Open harness wire or disconnected connector between key reminder switch and control unit	Repair the harness or plug in the connector correctly
			12-Ground: 0 v	A voltage same as or lower than system voltage	Defective key reminder switch	Check the key reminder switch. (Refer to GROUP 8-Ignition Switch.)
3	Insert the key.	Terminal voltage of control unit harness side connector (13-Ground, 12-Ground)	13-Ground: 0 v	A voltage same as or lower than system voltage	Defective key reminder switch	Check the key reminder switch. (Refer to GROUP 8-Ignition Switch.)
			12-Ground: System voltage	0 v	Open harness wire or disconnected connector between key reminder switch and control unit	Repair the harness or plug in the connector correctly
Buzzer						
1	Unplug the buzzer connector.	Terminal voltage of harness side connector (1 -Ground)	System voltage	0 V	Open harness wire or disconnected connector between junction block and buzzer	Repair the harness or plug in the connector correctly
2	Plug in the buzzer connector. Unplug the connector from the control unit	Terminal voltage of control unit harness side connector (20-Ground)	System voltage	0 V	Open harness wire or disconnected connector between buzzer and control unit	Repair the harness or plug in the connector correctly

SERVICE POINTS OF REMOVAL

19. REMOVAL OF LIFTGATE STOPPER

Caution

1. Never try to disassemble the liftgate gas spring or bum it.
2. Always bore a hole in the gas spring to release the interior gas before the spring is discarded.

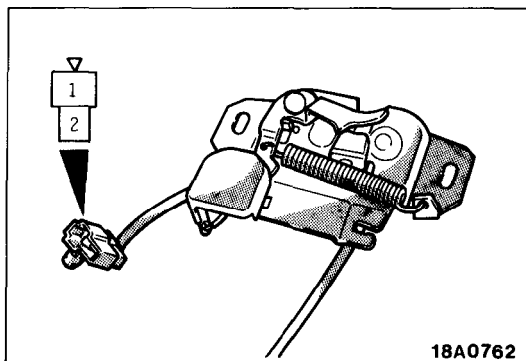

18A0762

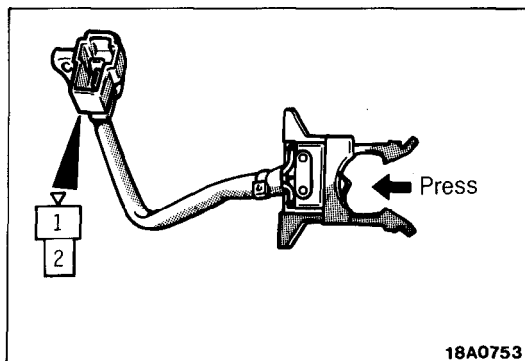

18A0753

INSPECTION

LIFTGATE SWITCH

- (1) Unlock the liftgate latch.
- (2) Check the continuity between the terminals.

Terminal	1	2
Liftgate latch locked		
Liftgate latch unlocked	0—	—0

NOTE

○—○ indicates that there is continuity between the terminals.

LIFTGATE LOCK CYLINDER SWITCH

Check to be sure that there is continuity between connector terminals 1 and 2 when the switch part shown in the illustration is not pressed, and that there is no longer continuity when it is pressed.

SERVICE POINTS OF INSTALLATION

16. APPLICATION OF GREASE TO LIFTGATE LOCK RELEASE HANDLE/ 11. LIFTGATE LATCH

Apply multipurpose grease to all moving parts.

Grease: MOPAR Multipurpose Grease Part No. 2932524 or equivalent

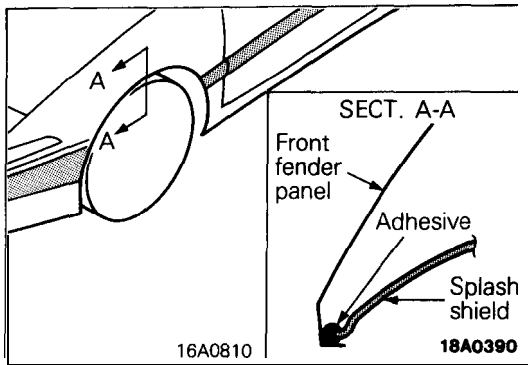

2. APPLICATION OF ADHESIVE TO SPLASH SHIELD

When installing the splash shield, apply specified adhesive to the flange part of the fender.

Specified adhesive: MOPAR Silicone Rubber Sealer Part No. 4026070 or Auto Glass Adhesive and Sealer Part No. 2298825 or equivalent

SERVICE POINTS OF INSTALLATION

3. APPLICATION OF GREASE TO FRONT DOOR WINDOW REGULATOR

Apply multipurpose grease to all moving parts.

Grease: MOPAR Multipurpose Grease Part No. 2932524 or equivalent

POWER WINDOW

REMOVAL AND INSTALLATION

N23MHA Ea

Post-installation Operation
 ● Door Window Glass Adjustment
 (Refer to P.23-32.)

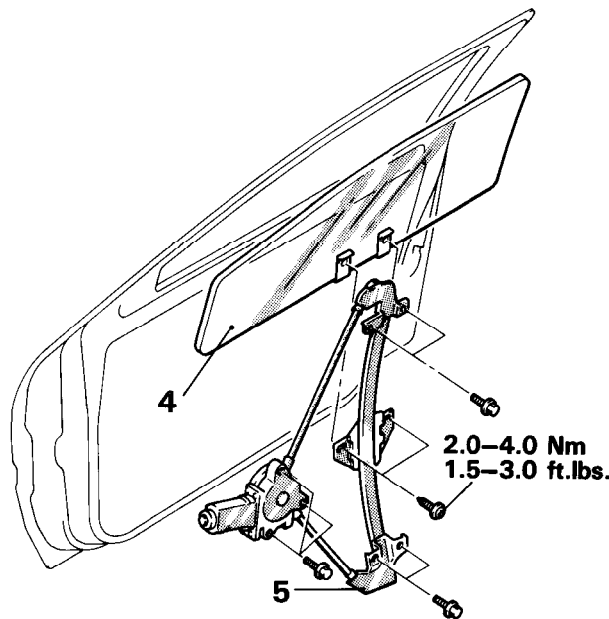

18A0507

<Driver's seat side>

< Passenger's seat side >

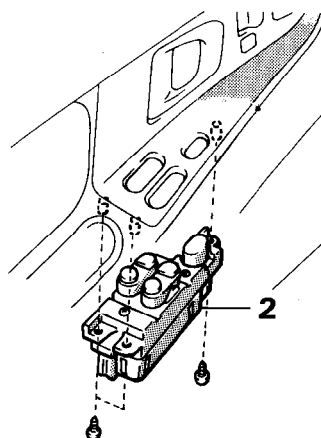

18A0469

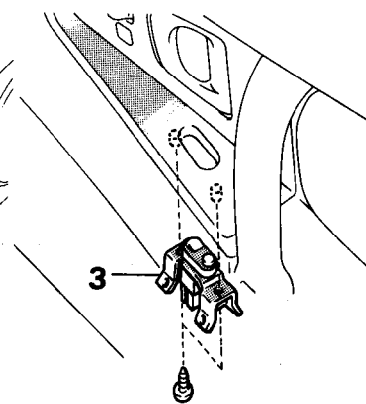

18A0468

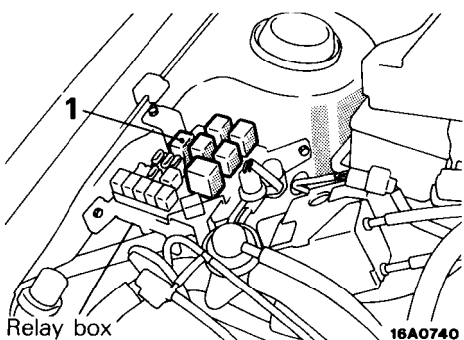

18A0740

Power window relay removal

- 1. Power window relay

Power window switch removal steps

- Door trim (Refer to P.23-65.)
- 2. Power window main switch
- 3. Power window sub switch

Power window motor removal steps

- Door trim and waterproof film (Refer to P.23-65.)
- 4. Door window glass
- + 5. Front door window regulator

NOTE

- (1) Reverse the removal procedures to reinstall.
- (2) ● +: Refer to "Service Points of Installation".

INSPECTION

POWER WINDOW RELAY

Apply battery voltage to terminal 2, and check for continuity when terminal 4 is grounded.

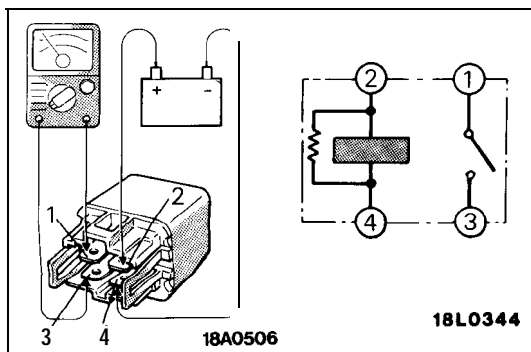

18A0506

18L0344

	Terminal	1	2	3	4
Battery voltage					
Continuity no voltage			○	○	○
Continuity with voltage		○		○	

NOTE

0-0 indicates that there is continuity between the terminals.

DISASSEMBLY AND REASSEMBLY

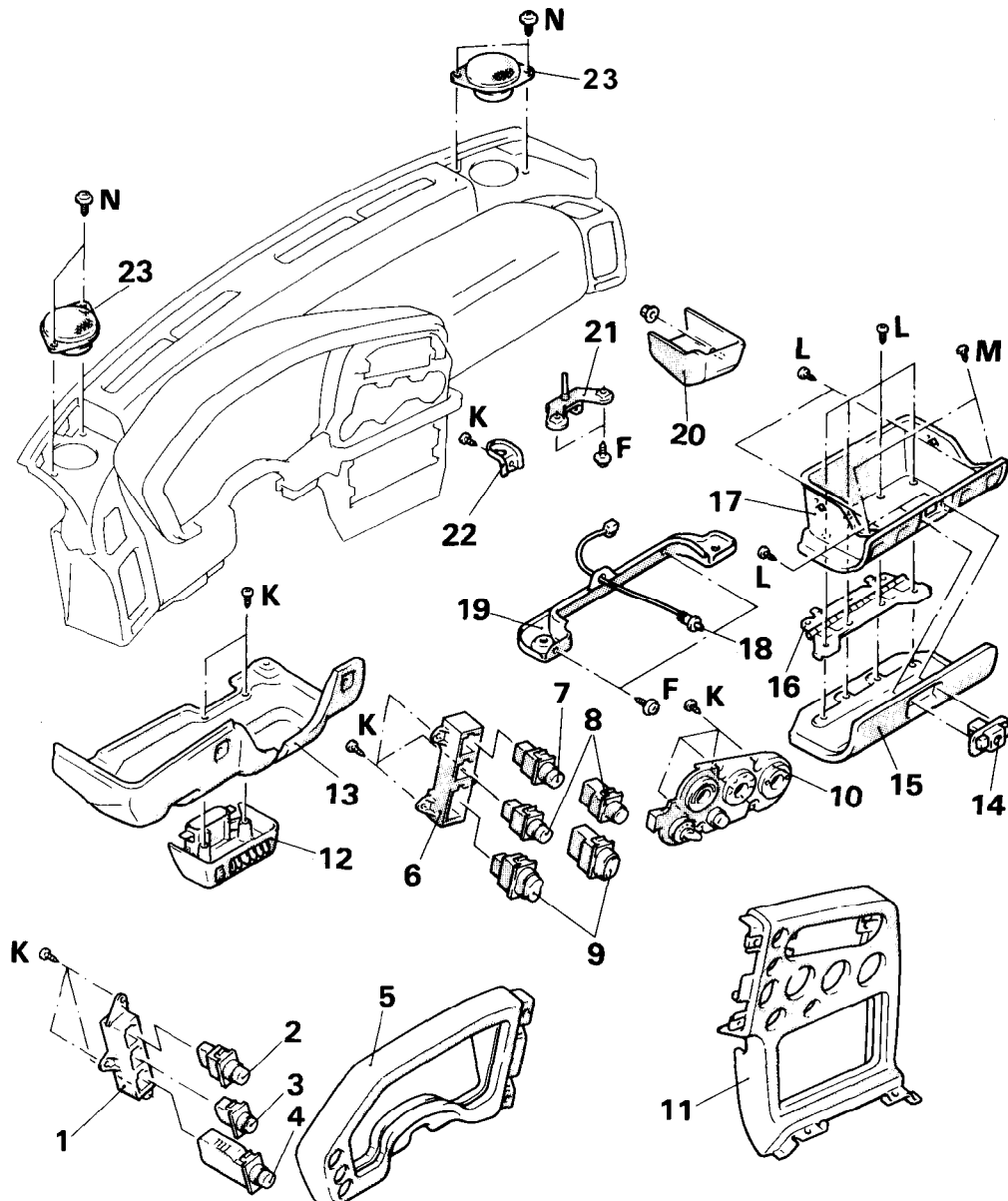

19A0279

Cluster panel (A) disassembly steps

1. Switch holder (A)
2. Headlight pop-up switch
3. Plug (A)
4. Rheostat
5. Cluster panel (A)

Cluster panel (B) disassembly steps

6. Switch holder (B)
7. Hazard switch
8. Rear window defogger switch or plug (A)
9. Rear wiper and washer switch or plug (B)
10. Heater control panel assembly
11. Cluster panel (B)

Knee protector disassembly steps

12. Lap cooler grill assembly
13. Knee protector

Glove box disassembly steps

14. Glove box lock assembly
15. Glove box pad
16. Glove box hinge
17. Glove box

Instrument panel disassembly steps

18. Glove box light switch
19. Lower frame
20. Corner pad
21. Glove box striker
22. Glove box light bracket
23. Speakers

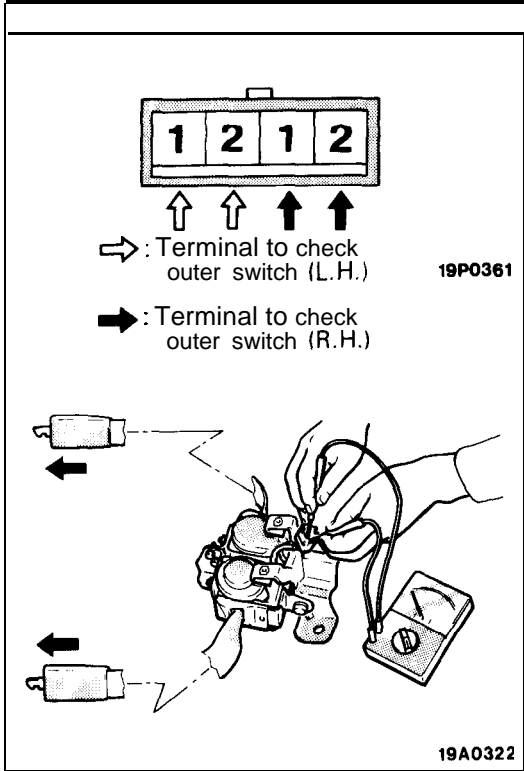

OUTER SWITCH

- (1) Disconnect the outer switch connector.
- (2) Pull out the shoulder belt farther than its midpoint and check the continuity between the terminals.

Condition	Terminal 1	Terminal 2
When the belt is pulled out farther than approx. the midpoint	○	○
When the belt is not pulled out as far as approx. the midpoint		

NOTE

- (1) The above inspection permits verification that the outer switch turns on when the shoulder belt is properly engaged with the slide anchor. The "midpoint" in the above procedure refers to the center of the belt length between the retractor and slide anchor.
- (2) O-O indicates that there is continuity between the terminals.

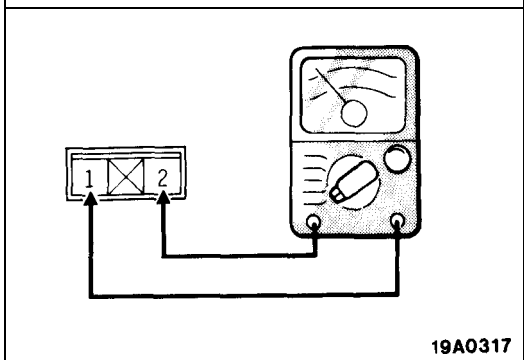

BUCKLE SWITCH

- (1) Disconnect the buckle switch connector (L.H. only).
- (2) Check the continuity between the terminals.

Terminal	1	2
Buckle unlock	○	○
Buckle lock		

NOTE

O-O indicates that there is continuity between the terminal.

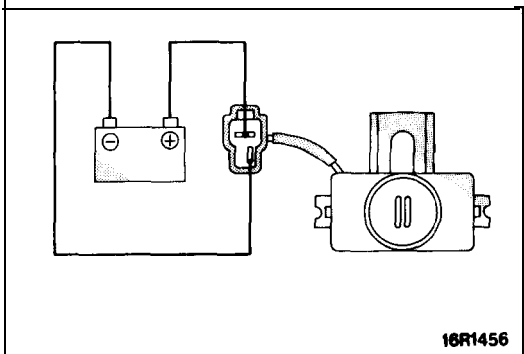

BUZZER

Check that buzzer sounds when battery voltage is applied to the buzzer terminal.

24-12 HEATERS AND AIR CONDITIONING – Service Adjustment Procedures

- (3) If the sight glass is clear and the magnetic clutch is disengaged; the clutch is faulty or, the system is out of refrigerant. Perform low pressure switch test to determine condition. Check low pressure switch, and clutch coil for electrical continuity.
- (4) If the sight glass shows foam or bubbles, the system could be low on charge. Occasional foam or bubbles are normal when the ambient temperature is above 43°C (110°F) or below 21°C (70°F).

Adjust the engine speed to 1,500 rpm. Block the air-flow thru the condenser to increase the compressor discharge pressure to 1,422 to 1,520 kPa (206 to 220 psi). If sight glass still shows bubbles or foam, system charge level is low.

The refrigerant system will not be low on charge unless there is a leak. Find and repair the leak. If the leak can be repaired without discharging the system an oil level check is not necessary. Use the procedure for correcting low refrigerant level found in the Refrigerant System Service Procedure Section.

DUAL PRESSURE SWITCH

The dual-pressure switch is a combination of the low-pressure switch (for checking the quantity of refrigerant) and the, high-pressure switch (for prevention of overheating); it is installed on the tube, and, when the pressure becomes approximately 210 kPa (30 psi) or lower, the compressor stops, thus preventing the compressor from being damaged by heat. When the pressure reaches 2,700 kPa (384 psi) or higher, the compressor stops, thus preventing overheating. There is generally no necessity for inspection; if, however, an unusual condition, such as non-operation of the compressor is encountered, check by following the procedures below.

- (1) Check for continuity of the dual-pressure switch.

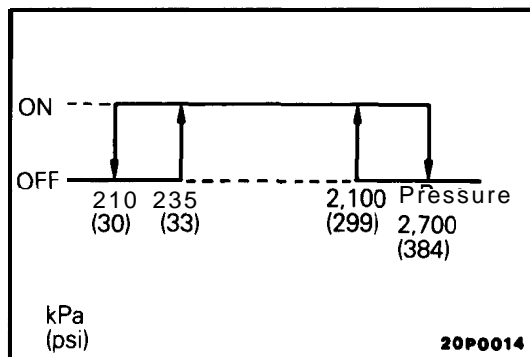

Usual condition	Continuity
Insufficient refrigerant	No continuity
Unusually high temperature	

NOTE

If the air temperature drops to 0°C (32°F) or lower during cold weather, the air conditioner will not operate (no continuity).

- (2) If there is an insufficient amount of refrigerant, check the refrigerant amount by looking through the sight glass of the receiver; supply refrigerant if necessary. (Refer to P.24-21.)

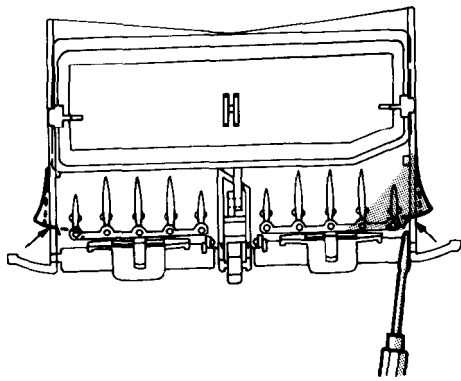

19A0274

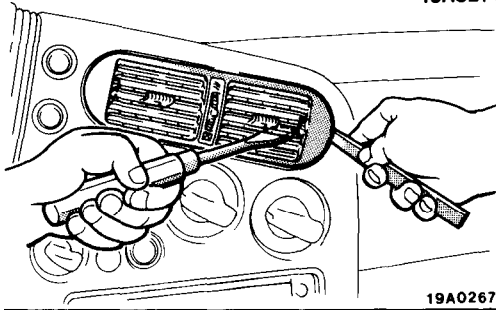

19A0267

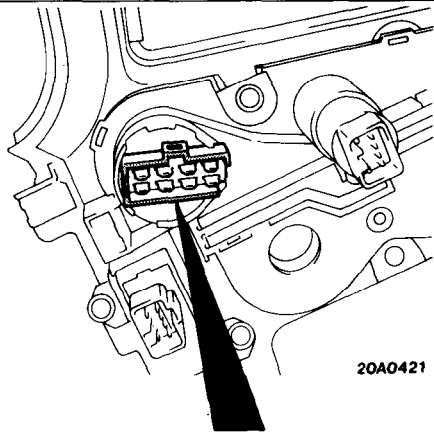

20A0421

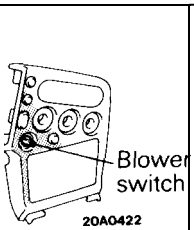
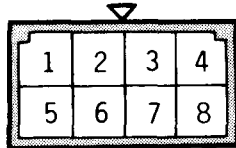

20A0422

20A0408

SERVICE POINTS OF REMOVAL

N24GBAL

5. REMOVAL OF CENTER AIR OUTLET ASSEMBLY

Disengaging the tabs of the center air outlet assembly with a flat tip (-) screwdriver, remove the center air outlet assembly with a plastic trim tool.

INSPECTION

N24GCAG

BLOWER SWITCH

Operate the switch, and check the continuity between the terminals.

Terminal	5	3	6	2	7	8	1	4
Switch position								
OFF								
• (Low)	o - - o					o - - o		
● (Medium first step)	o ——— o					o — o		
● (Medium second step)	o ——— o					o — o — o		
● (High)	o ——— o				o	o — o — o		

NOTE

○—○ indicates that there is continuity between the terminals.

COMPRESSOR DISASSEMBLY AND REASSEMBLY

N24SE--

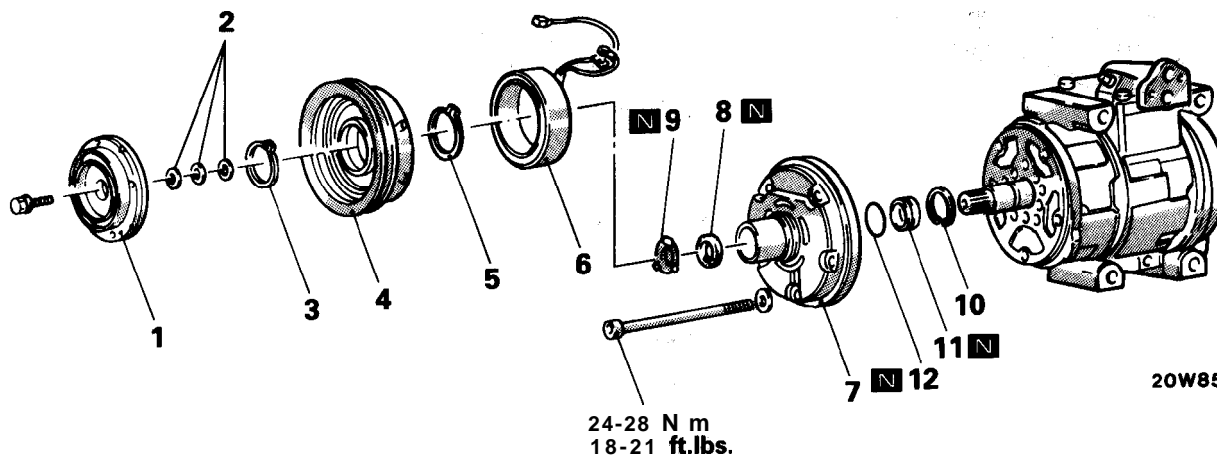

Magnetic clutch disassembly steps

- ◄◄◄◄ 1. Clutch hub
- 2- Shim
- ◄◄ 3. Snap ring
- ◄◄ 4. Rotor
- 4 5. Snap ring
- 4 6. Clutch coil

Shaft seal disassembly steps

- + 7. Front housing
- ◄◄ 8. Felt
- 9. Felt holder
- 10. Snap ring
- ◄◄ ● + 11. Shaft seal
- 12. O-ring

NOTE

- (1) Reverse the disassembly procedures to reassemble.
- (2) ◄◄◄◄: Refer to "Service Points of Disassembly".
- (3) ◄◄◄◄: Refer to "Service Points of Reassembly".
- (4) ◻: Non-reusable parts.

SERVICE POINTS OF DISASSEMBLY

N24SFAC

1. REMOVAL OF CLUTCH HUB

- (1) Fix the compressor with a vise. At this time, the rear housing of the compressor must be in contact with the vise.
- (2) If the clutch hub cannot be pulled off by hand, screw in an 8 mm (.315 in.) completely threaded bolt so as to raise the clutch hub so it can be removed.

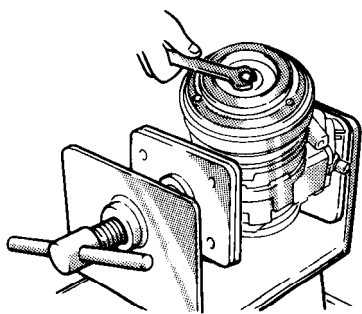

20W857

4. REMOVAL OF ROTOR

Using a plastic hammer, lightly tap the rotor off the shaft.

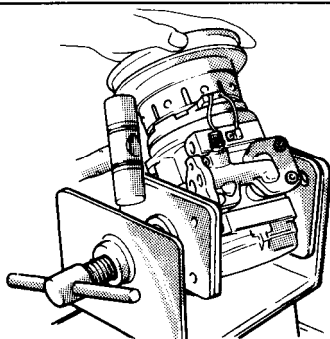

20W858

<Federal and Canada–2.0L DOHC Engine Non-Turbo>

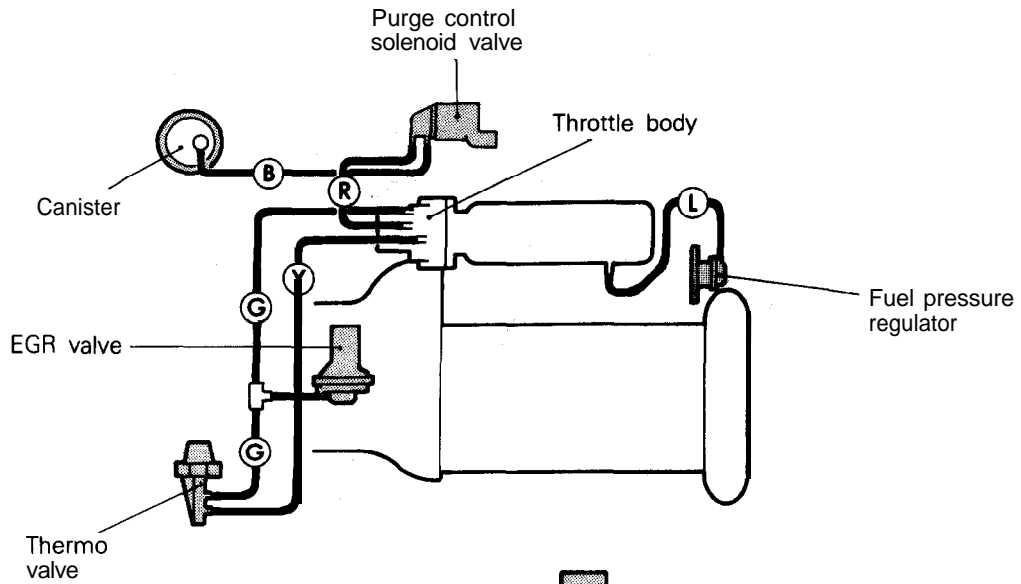

- G: Green
- Y: Yellow
- L: Light blue
- R: Red
- B: Black



6EM0191

<California–2.0L DOHC Engine Non-Turbo>

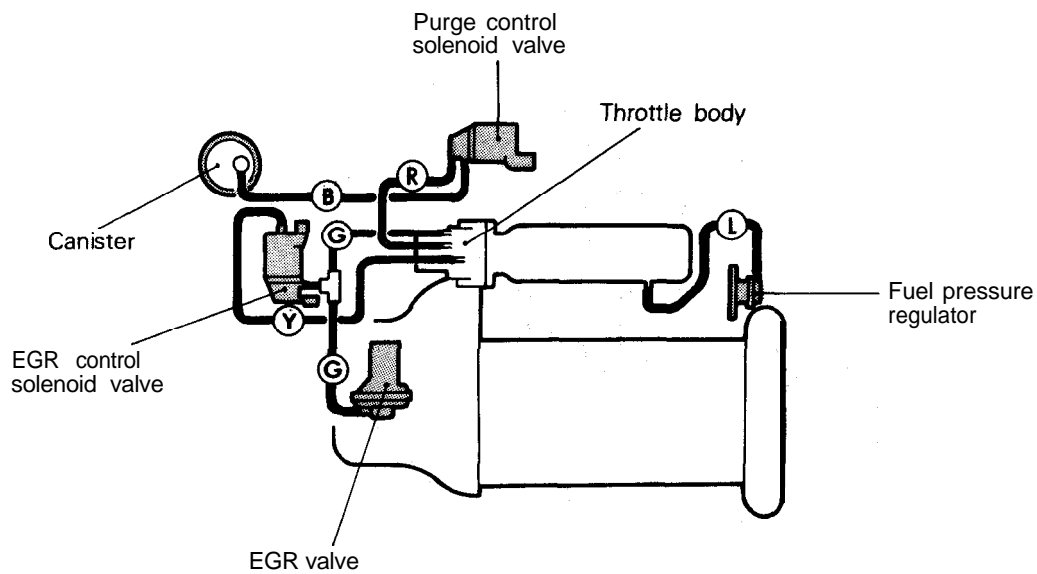

- G: Green
- Y: Yellow
- L: Light blue
- R: Red
- B: Black



6EM0192

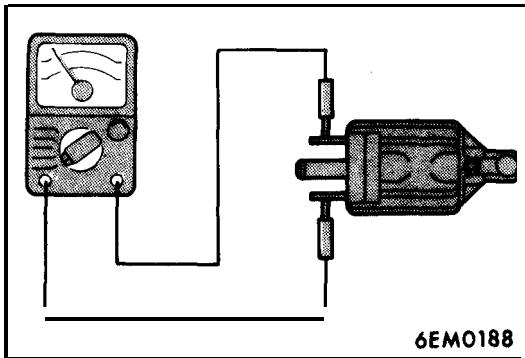

- (5) Measure the resistance between the terminals of the solenoid valve.

Standard value: 36-44 Ω [at 20°C (68°F)]

AIR-FUEL RATIO CONTROL (MPI) SYSTEM N25CAD

- To inspect the air-fuel ratio control (MPI) system, refer to GROUP 14 FUEL SYSTEM-Service Adjustment Procedures.
- For detailed information concerning the illumination pattern of the malfunction-indicator light and other aspects of the self-diagnosis function, refer to GROUP 14 FUEL SYSTEM-Self Diagnosis.

CATALYTIC CONVERTER N25CBH

INSPECTION.

Inspect for damage, cracking or deterioration. Replace if faulty.

Caution

1. Operation of any type, including **idling**, should be avoided if engine misfiring occurs. Under this condition the exhaust system will operate at **abnormally** high temperature, which may cause damage to **the catalyst** or underbody parts of the vehicle.
2. Alteration or deterioration of ignition or fuel system, or any type of operating condition which results in **engine** misfiring must be corrected to avoid overheating the catalytic converters.
3. Proper maintenance and tune up according to manufacturer's specifications should be made to correct the conditions as soon as possible.

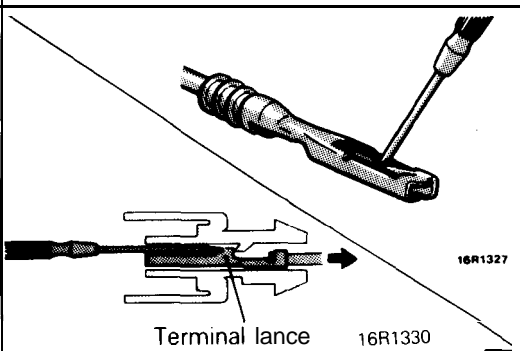
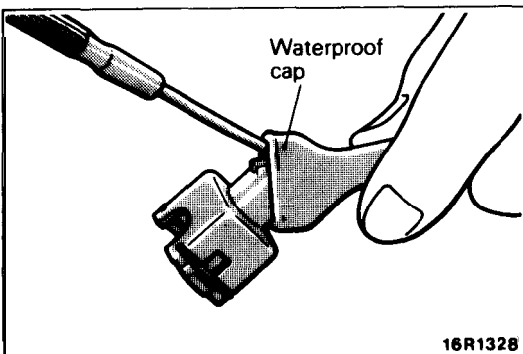
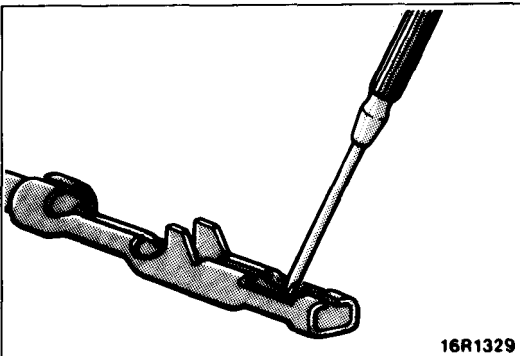
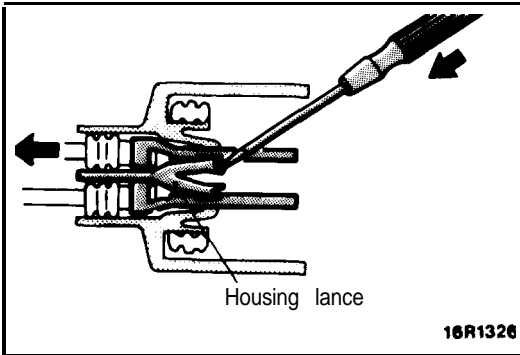
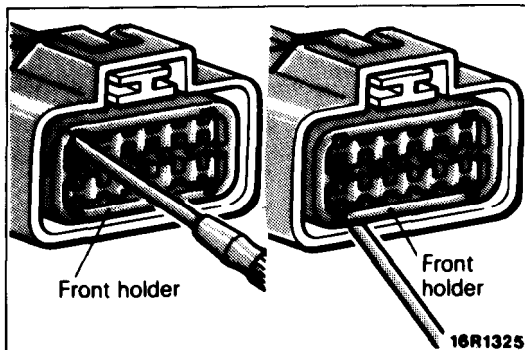
**RECTANGULAR WATERPROOF CONNECTOR**

(1) Disengage front holder by using a screwdriver and remove it.

(2) Insert tip of screwdriver ("0.8 mm (.03 in.) width] into connector in a manner as shown in the figure, push it lightly to raise housing lance and pull out harness.
 ● If right size screwdriver is not available, convert a conventional driver to suit the size.

(3) Press contact point of male terminal down by holding a screwdriver [1.4 mm (.06 in.) width] in a manner as shown in the figure.

INJECTOR CONNECTOR

(1) Remove waterproof cap.

(2) Insert tip of screwdriver (1.4 mm (.06 in.) width] into connector in a manner as shown in the figure, press in terminal lance and pull out harness.

(3) Press contact point of male terminal down by holding a screwdriver [1.4 mm (.06 in.) width] in a manner as shown in the figure.

Caution

Correct lance to be in proper condition before terminal is inserted into connector.

ENGINE COMPARTMENT <2.0L DOHC Engine (Non-Turbo)>

Connector symbol

A

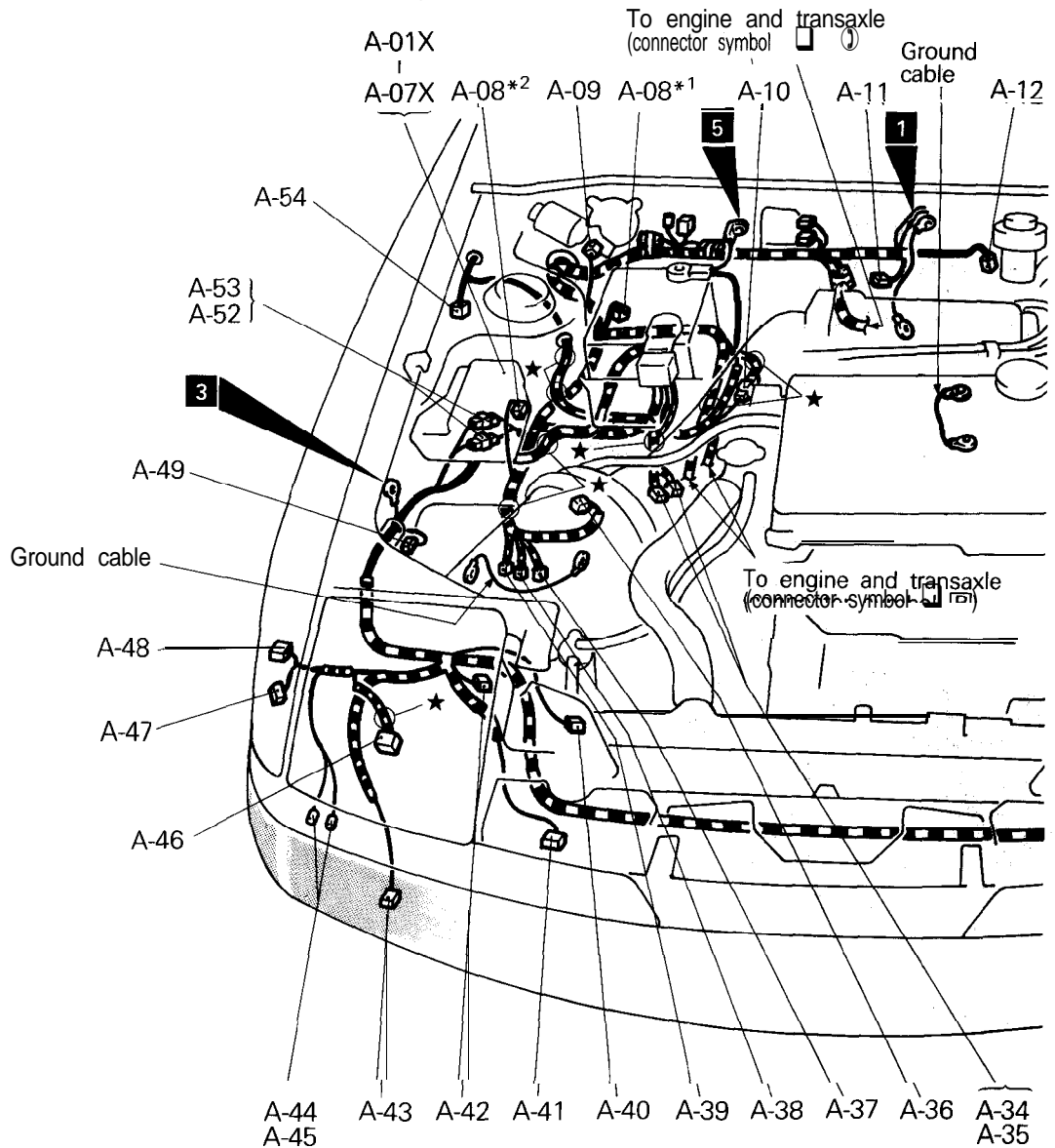

- A-01X Taillight relay
 - A-02X Headlight relay
 - A-03X Radiator fan motor relay
 - A-04X Pop-up motor relay
 - A-05X Power window relay
 - A-06X Alternator relay
 - A-07X Fog light relay
 - A-08 Dual pressure switch (for air conditioner circuit)
 - A-09 Wiper motor
 - A-10 Control wiring harness and battery cable assembly combination
 - A-11 Auto-cruise control vacuum pump
 - A-12 Brake fluid level sensor
 - A-13 —
 - A-14 Purge control solenoid valve
 - A-15 —
 - A-16 EGR control solenoid valve (Vehicles for California)
- } Refer to CENTRALIZED JUNCTION

- A-17X Condenser fan motor high-low changeover relay
 - A-18X Condenser fan motor relay
 - A-19X Magnetic clutch relay
 - A-20X Condenser
 - A-21 } Air conditioner relay box
 - A-22 }
 - A-23 ABS front speed sensor (Left side)
 - A-24 Washer motor
 - A-25 Pop-up motor (Left side)
 - A-26 } Front combination light (Left side)
 - A-27 }
 - A-28 Headlight (Left side)
 - A-29 } Horn (Left side)
 - A-30 }
 - A-31 Fog light (Left side)
 - A-32 Condenser fan motor (for air conditioner circuit)
 - A-33 Front turn-signal light (Left side)
- } Refer to CENTRALIZED JUNCTION (for air conditioner circuit)

Indicates terminal No.

A broken line indicates that these connectors are the same intermediate connectors.

Indicates that the diagram is continued from  on the previous page.

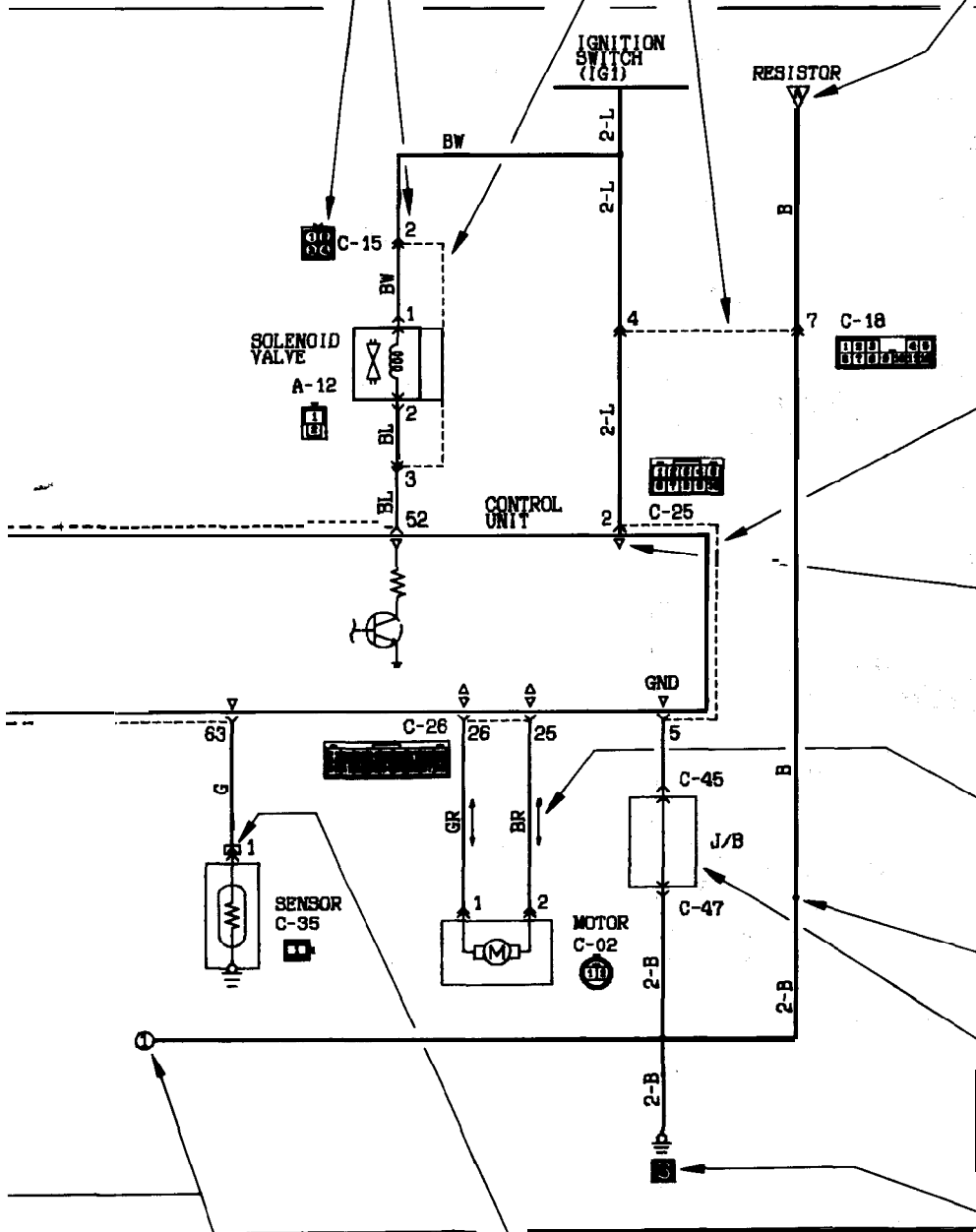

In case two or more connectors are connected to the same device, markings indicating the same connector are connected by a broken line.

Indicates input/output to/from control unit (current flow direction).

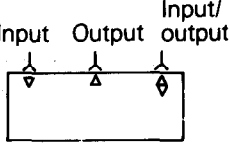

Indicates current flow downward or upward as controlled by the control unit.

Indicates harness junction where wire diameter or color changes.

Indicates J/B (Junction Block).

Indicates vehicle body ground point. (Same No. as that of ground point in ELECTRICAL SYSTEM PARTS LOCATION)

Indicates continuity of harnesses on the opposite page of a double page circuit diagram.

Indicates that the terminal is a spare one if the device (sensor in this case) is not provided.

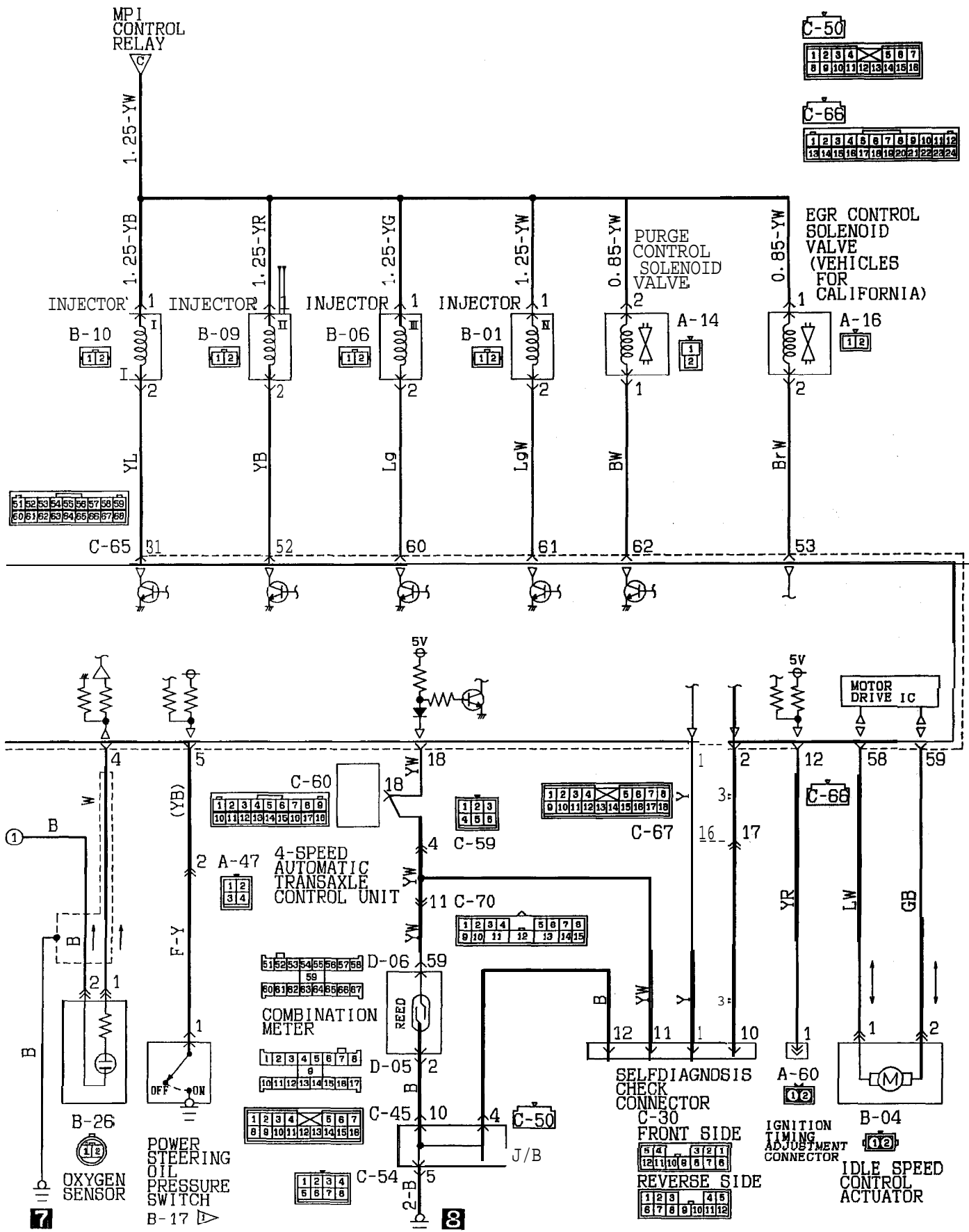

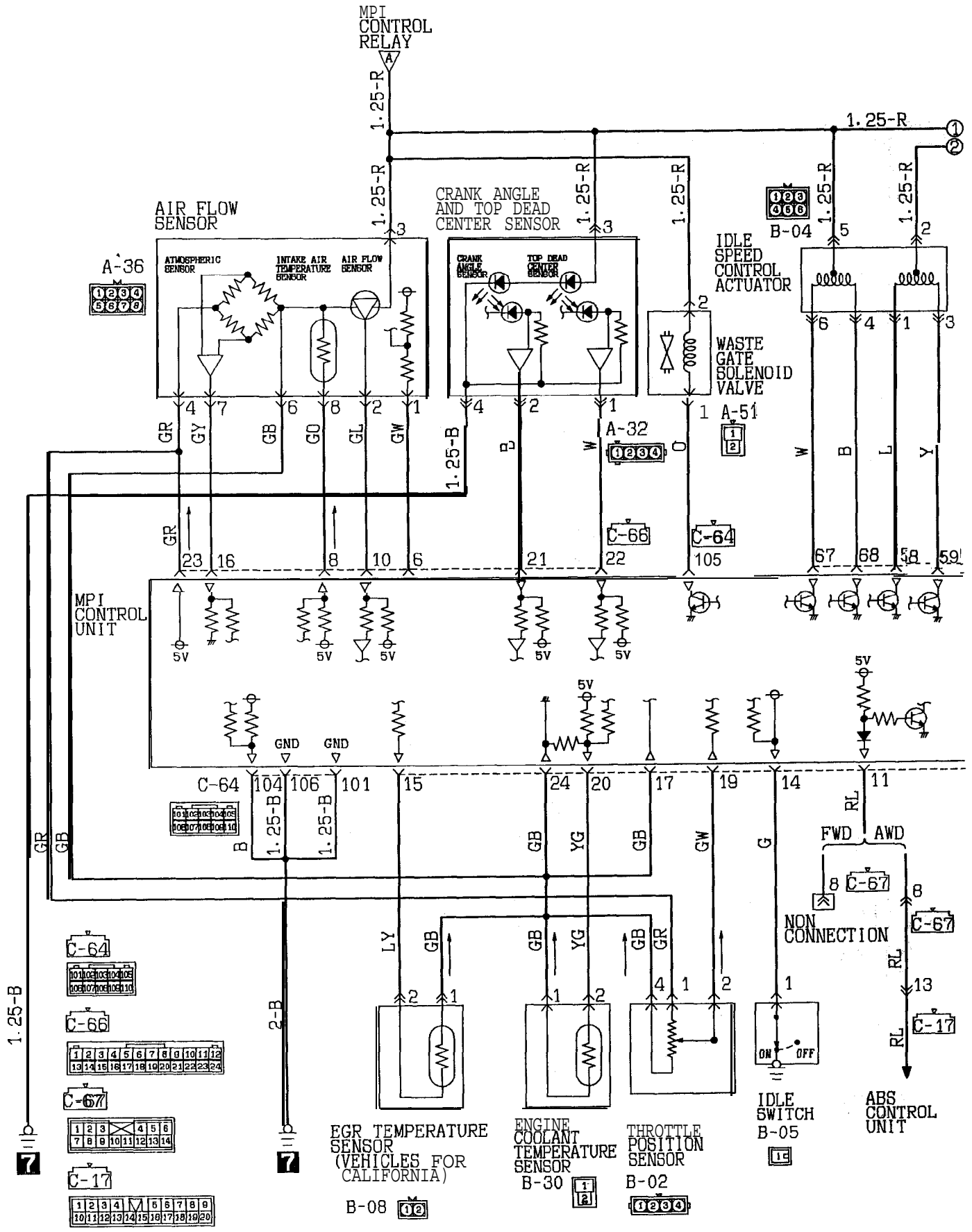

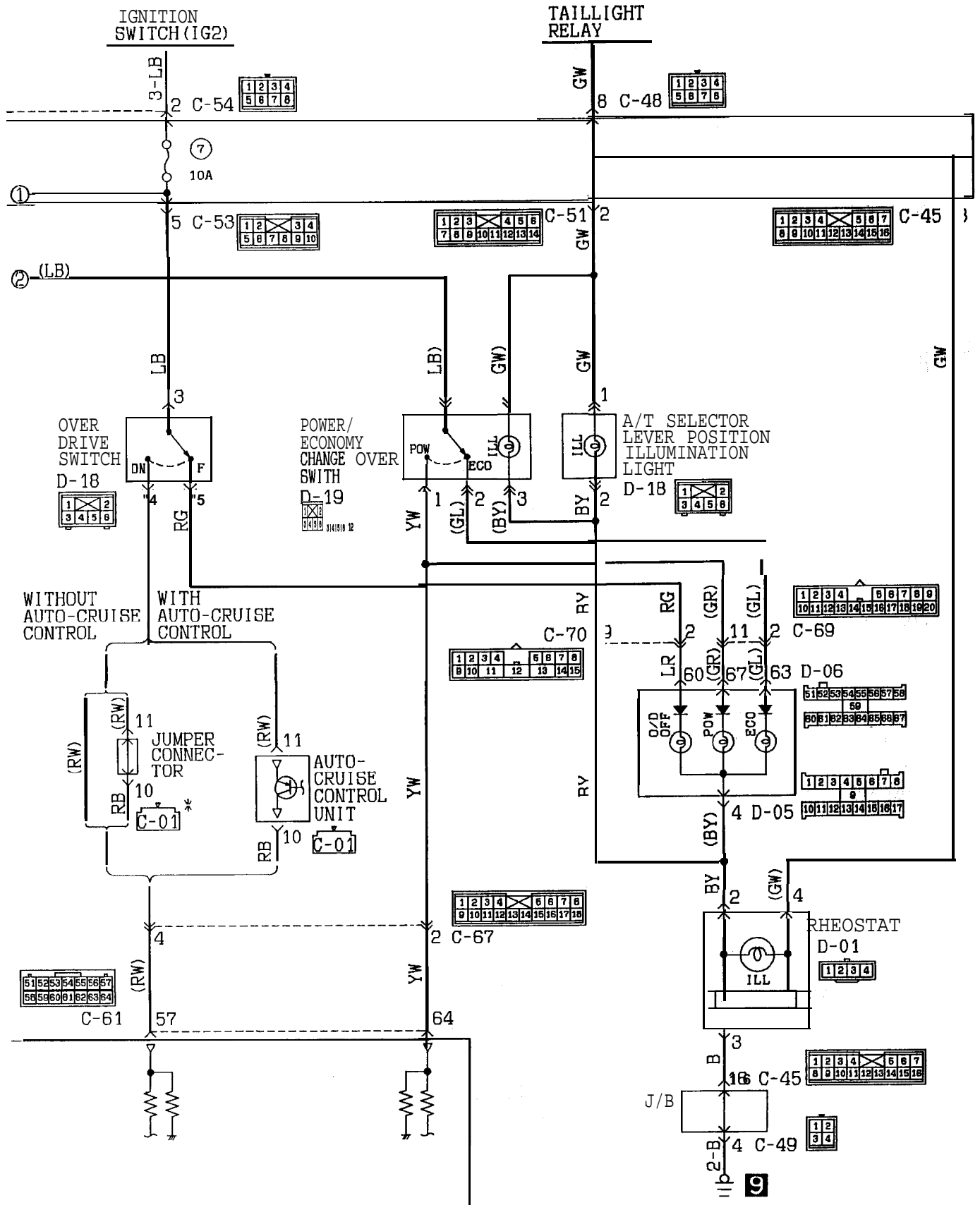

Remark
 *Mark indicates the optional wiring harness for auto-cruise control system.

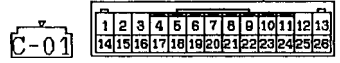

AUTOMATIC SEAT BELT CIRCUIT

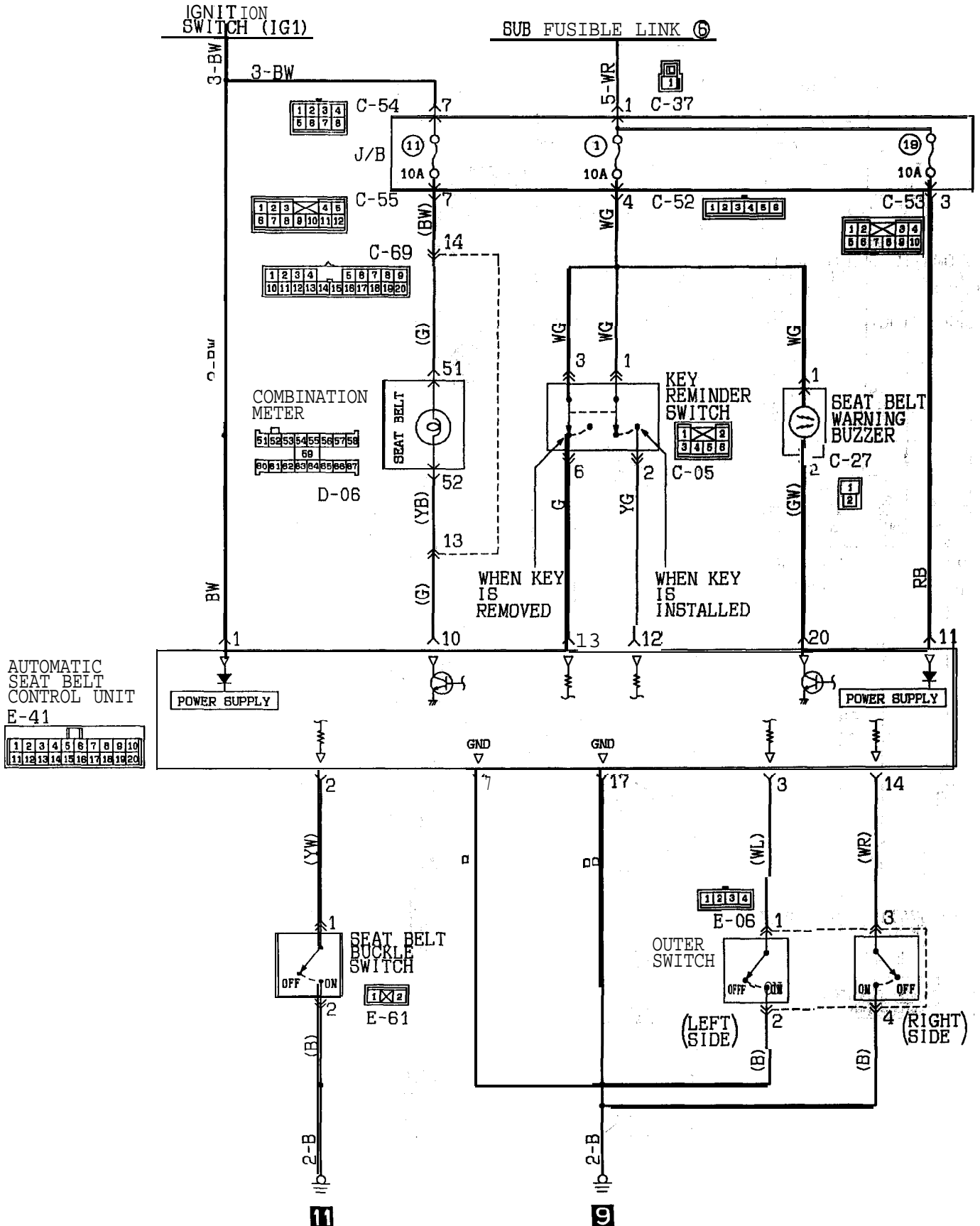

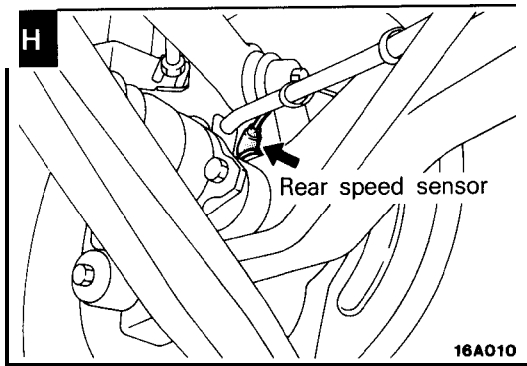

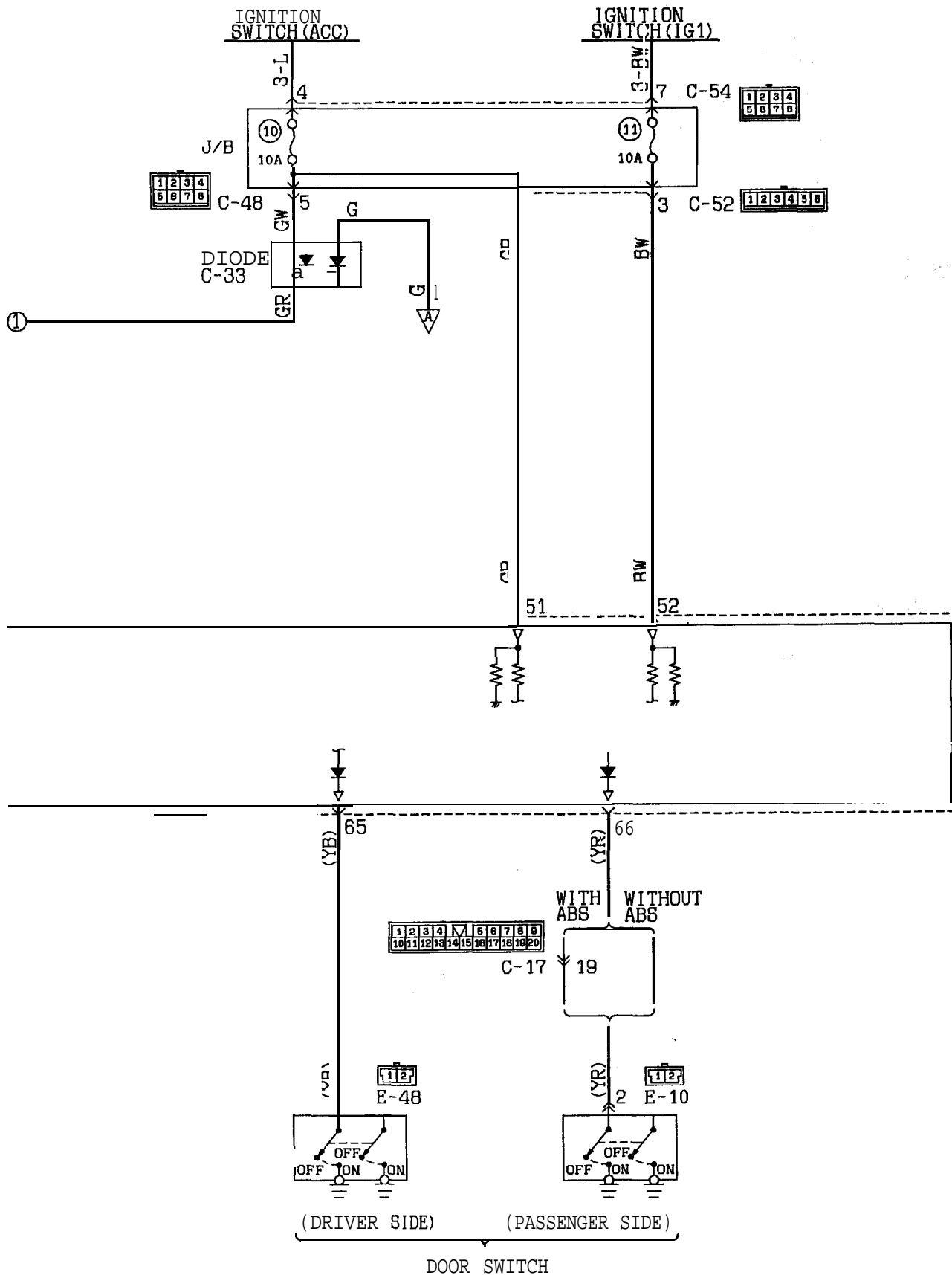

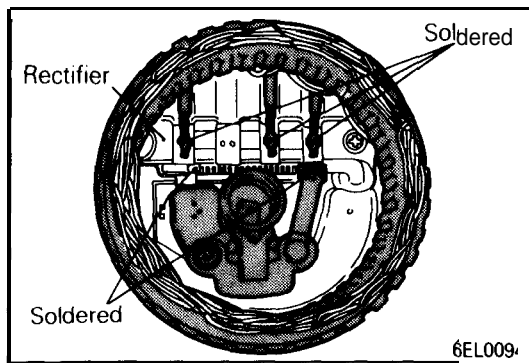

8. REMOVAL OF STATOR

- (1) When removing stator, unsolder three stator leads soldered to main diodes on rectifier.
- (2) When removing rectifier from brush holder, unsolder two soldered points to rectifier.

Caution

When soldering or unsoldering, use care to make sure that heat of soldering iron is not transmitted to diodes for a long period. Finish soldering or unsoldering in as short a time as possible.

Use care that no undue force is exerted to leads of diodes.

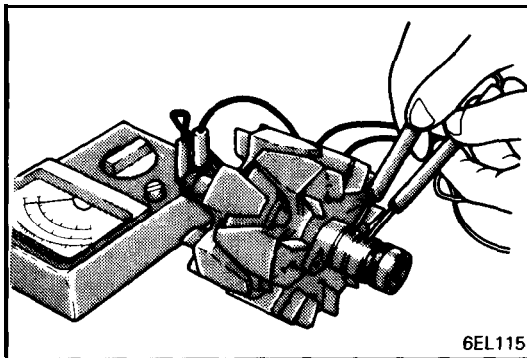

INSPECTION

ROTOR

- (1) Check rotor coil for continuity. Check to ensure that there is continuity between slip rings. If resistance is extremely small, it means that there is a short. If there is no continuity or if there is short circuit, replace rotor assembly.

Resistance value: 3–5 Ω

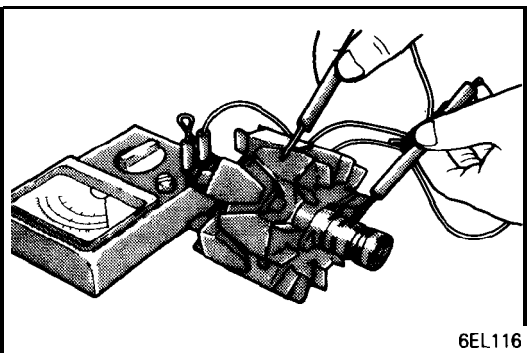

- (2) Check rotor coil for grounding. Check to ensure that there is no continuity between slip ring and core. If there is continuity, replace rotor assembly.

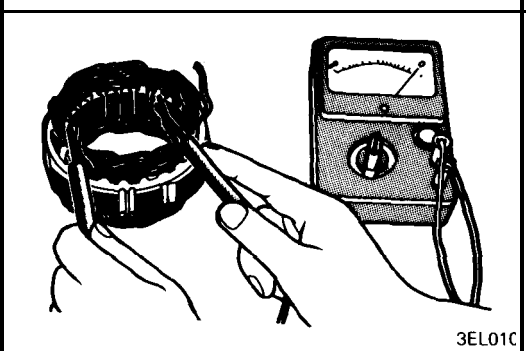

STATOR

- (1) Make continuity test on stator coil. Check to ensure that there is continuity between coil leads. If there is no continuity, replace stator assembly.

STARTER MOTOR (REDUCTION DRIVE TYPE)

DISASSEMBLY AND REASSEMBLY

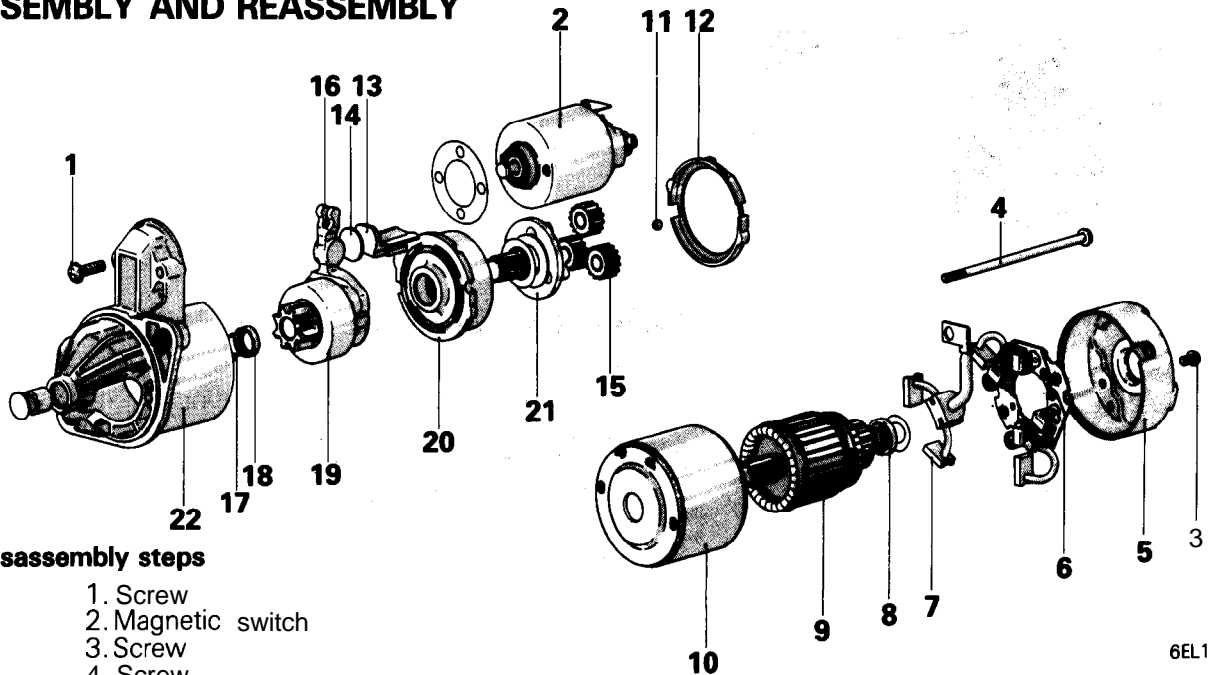

Disassembly steps

- 1. Screw
- 2. Magnetic switch
- 3. Screw
- 4. Screw
- 5. Rear bracket
- 6. Brush holder
- 7. Brush
- 8. Rear bearing
- 9. Armature
- 10. Yoke assembly
- 11. Ball
- 12. Packing A
- 13. Packing B
- 14. Plate
- 15. Planetary gear
- 16. Lever

- ◆◆◆◆ 17. Snap ring
- ◆◆◆◆ 18. Stop ring
- 19. Overrunning clutch
- 20. Internal gear
- 21. Planetary gear holder
- 22. Front bracket

NOTE

- (1) Reverse the disassembly procedures to reassemble.
- (2) ◆◆: Refer to "Service points of Disassembly".
- (3) ● +: Refer to "Service Points of Reassembly".

6EL199

SERVICE POINTS OF DISASSEMBLY

9. REMOVAL OF ARMATURE / 11. BALL

Caution

When removing the armature, take care not to lose the ball (which is used as a bearing) in the armature end.

17. REMOVAL OF SNAP RING / 18. STOP RING

- (1) Press the stop ring, by using an appropriate socket wrench, to the snap ring side.

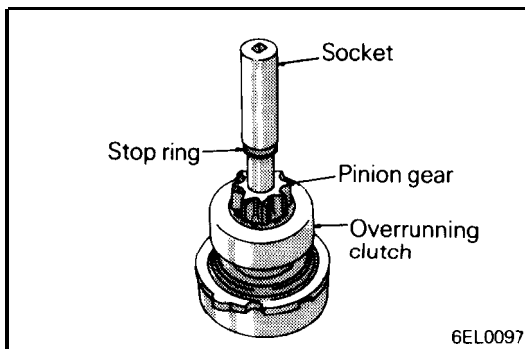

6EL0097

REMOVAL AND INSTALLATION <2.0L DOHC Engine>

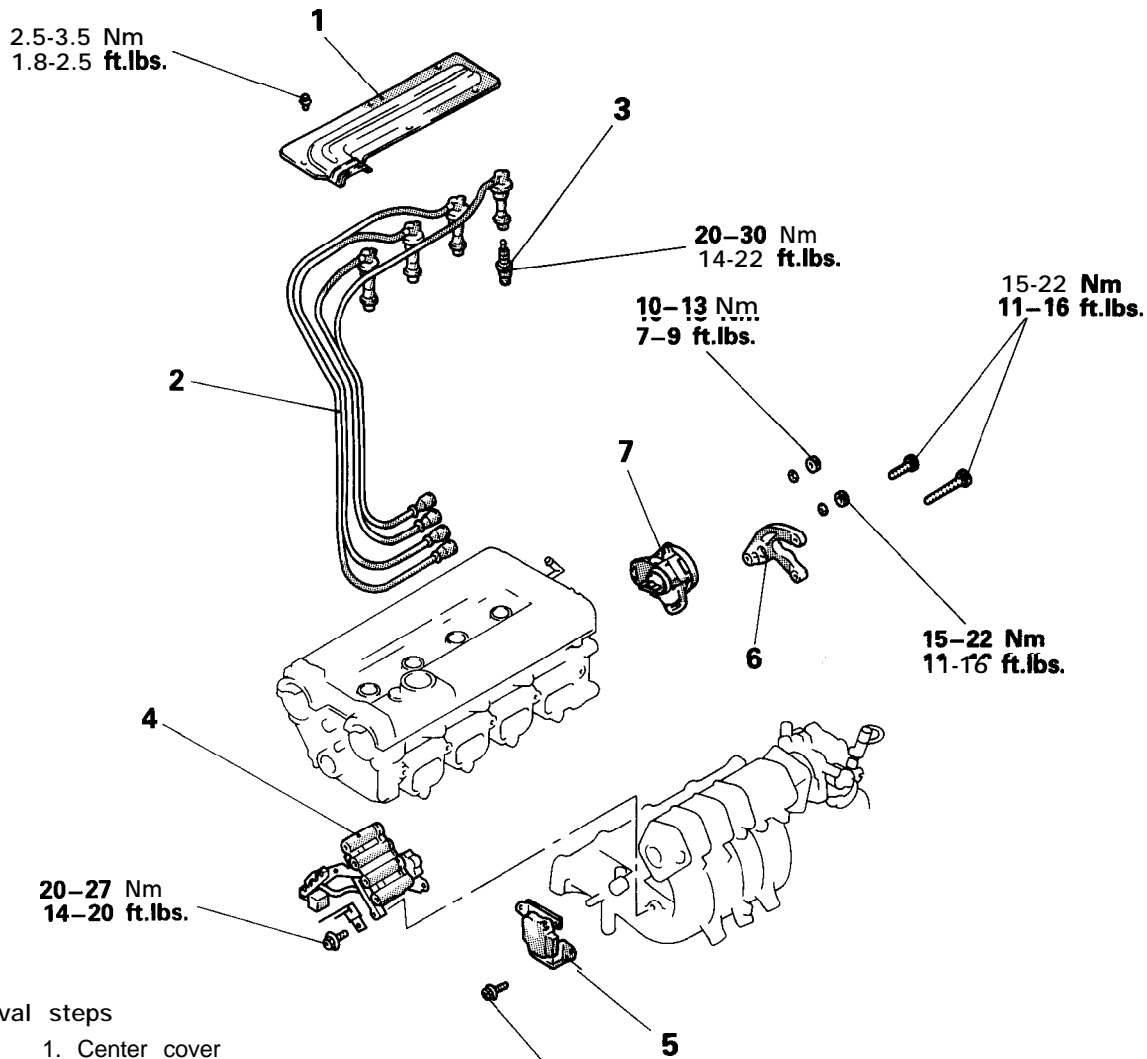

Removal steps

- 1. Center cover
- • + 2. Spark plug cable
- 3. Spark plug
- 4. Ignition coil
- 5. Power transistor
- 6. Throttle body stay
- ◆◆ 7. Crank angle sensor

10-12 Nm
7-9 ft.lbs.

NOTE

- (1) Reverse the removal procedures to reinstall.
- (2) • • *: Refer to "Service Points of Removal".
- (3) • • +: Refer to "Service Points of Installation".

6EL0157

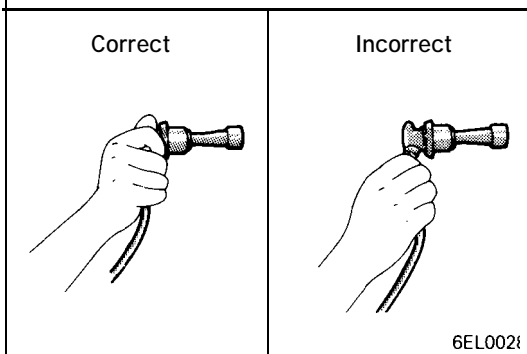

SERVICE POINTS OF REMOVAL
2. REMOVAL OF SPARK PLUG CABLE

When disconnecting cable, hold cap.

INSPECTION
SPARK PLUG

Refer to P.8-177 for inspection procedures.

SPARK PLUG CABLE

- (1) Check cap and coating for cracks.
- (2) Measure resistance.

Spark plug cable			
No. 1	No. 2	No. 3	No. 4
5.8	8.4	10.6	9.7

TROUBLESHOOTING

OPERATION

< Fuel gauge >

- When the ignition key is at the "ON" position, the fuel gauge is activated.
- When there is much fuel, the unit's resistance is small and the current flowing in the circuit is great, so the gauge's indicator indicates in the "F" area.
- When there is little fuel, the unit's resistance is high and the current flowing in the circuit is small, so the gauge's indicator indicates in the "E" area.

< Engine coolant temperature gauge >

- When the ignition key is at the "ON" position, the engine coolant temperature gauge is activated.
- When the engine coolant temperature is high, the unit's resistance is low and there is a great flow of current in the circuit, so the gauge's indicator indicates in the "H" area.
- When the engine coolant temperature is low, the unit's resistance is high and there is a small flow of current in the circuit, so the gauge's indicator indicates in the "C" area.

< Reed switch >

- Pulses are produced in accordance with the vehicle speed, and vehicle-speed signals are input to systems (the 4 A/T system, etc.) that regulate according to the vehicle speed.

< Oil Pressure Gauge >

- When the ignition switch is at the "ON" position, the oil pressure gauge is activated.
- When oil pressure is high, the internal contacts of the gauge unit are kept closed for a longer period of time. This causes more current to flow in the circuit, and the gauge pointer swings to the high pressure side.
- When oil pressure is low, the internal contacts of the gauge unit open in a shorter period of time. Therefore, there is less current flowing in the circuit and the gauge pointer swings to the low pressure side.

< Pressure meter >

- When the ignition key is set to the "ON" position, the gauge indicator will be at "0".
- When the engine is started, the indicator will move from "0" to the minus (-) side, and then, as the boost level increases, it will move to the plus (+) side.









NOTE

For operation of warning light and indicator light, refer to P.8-210 INDICATORS.

TROUBLESHOOTING HINTS

1. The fuel gauge doesn't function, or shows the incorrect indication.
 - (1) Disconnect the connector of the fuel gauge unit; the "F" side is indicated when terminal 3 (FWD) or 2 (AWD) is then grounded.
 - Check the fuel gauge.
2. The engine coolant temperature gauge doesn't function, or shows the incorrect indication.
 - (1) The "H" side is indicated when the connector of the engine coolant temperature gauge unit is disconnected and then grounded.
 - Check the engine coolant temperature gauge unit.
3. The oil pressure gauge doesn't function, or shows the incorrect indication.
 - (1) The "H" side is indicated when the connector of the oil pressure gauge unit is disconnected and then grounded.
 - Check the oil pressure gauge unit.
4. Systems dependent upon control according to the vehicle speed do not function correctly.
 - Check the reed switch (located within the speedometer).
5. The meter illumination light does not illuminate.
 - (1) The tail lights illuminate.
 - Check the rheostat.

INDICATORS

Symbol		Operation
	Turn signal indicator	This indicator flashes, as do the same side of turn-signal light flashes. If the turn-signal light is burnt out, the indicator flashes faster than normal indicator. This indicator is common with hazard light.
	High beam indicator	This indicator illuminates when the headlights are on high beam.
	Door-ajar warning	This indicator comes on when the door or liftgate is either open or not completely closed.
	Seat belt warning	<Vehicles with automatic seatbelt > This warning light warns the driver and front passenger to fasten their seat belts. If one or more seat belts are not fastened, the automatic seat belt control unit detects that fact and causes the warning light to be illuminated or flash. How long the light is illuminated or how many times it flashes depends on whether only one, or both of the belts remain unfastened.
		<Vehicles without automatic seatbelt > The seat belt warning light will flash for about six seconds when the ignition key is turned to the ON position. If at this time the driver's seat belt is not buckled, the alarm buzzer will sound four times in synchronism with the flashing of the warning light.
BRAKE	Brake warning (for U.S.A.)	This indicator comes on when the ignition key is in "ON" position, and goes off after the engine has started. This indicator comes on when the parking brake is applied or brake fluid level falls less than the specific level.
	Brake warning (for Canada)	
	Low fuel warning	This indicator comes on when the fuel in the fuel tank falls less than approx. 8 liters (2.1 gals.).
	Charging warning	This indicator comes on when the ignition key is in "ON" position, and goes off after the engine has started. This indicator comes on when the drive belt breaks or the trouble occurs in the charging system.
	Oil pressure warning	This indicator comes on when the ignition key is in "ON" position, and goes off after the engine has started. This indicator comes on when the oil fails or the trouble occurs in the oil circulating system while driving.
	Engine coolant level warning	This indicator illuminates when the coolant level in the radiator reservoir tank falls below the specified level.
CHECK ENGINE	Check engine warning light	This light illuminates when the ignition key is turned to the "ON" position, but should go out in a few seconds. If the light illuminates while the vehicle is moving, there is a malfunction of a component related to exhaust gases.

POP-UP MECHANISM
CIRCUIT DIAGRAM

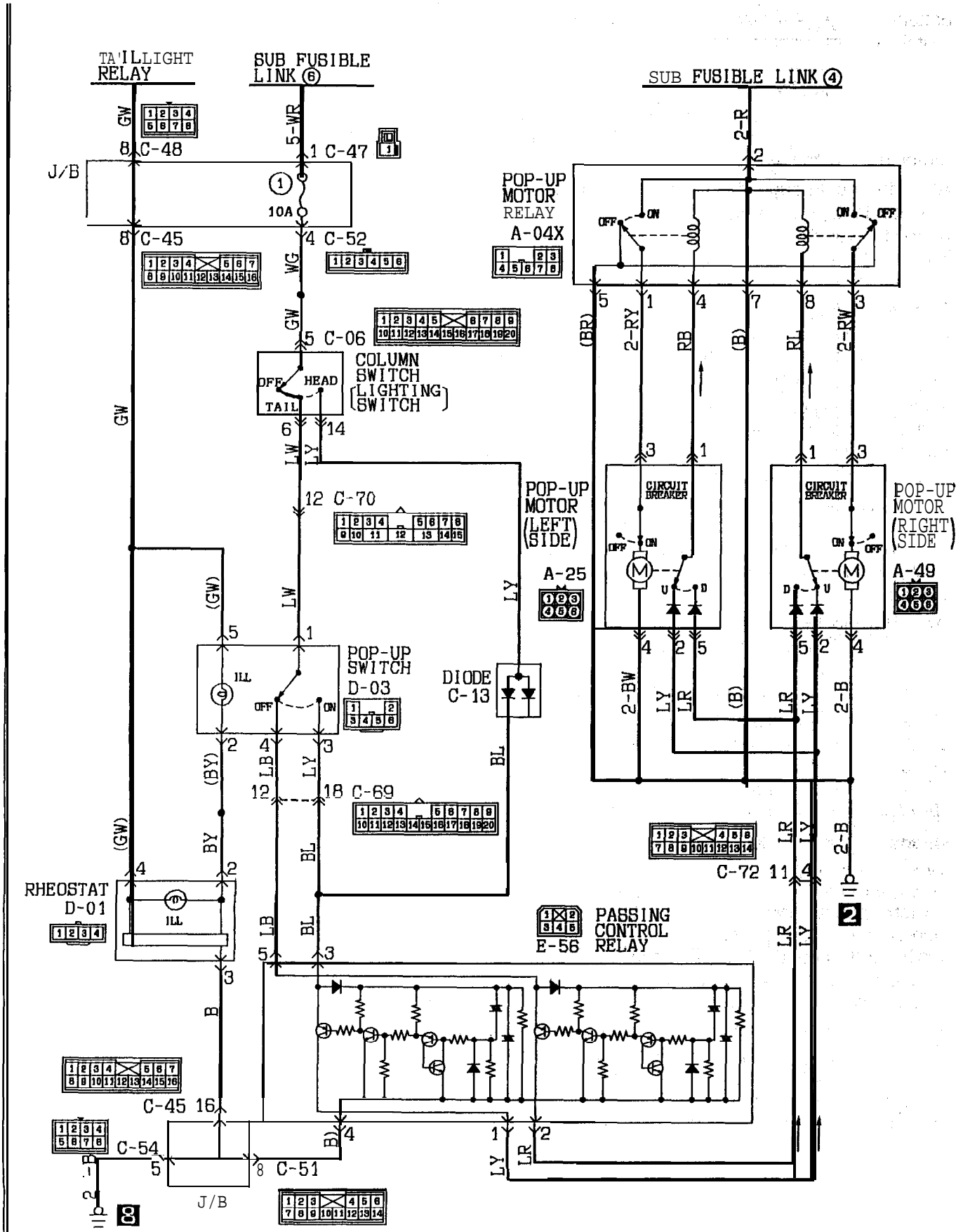

SERVICE POINTS OF REMOVAL

1. REMOVAL OF HEADLIGHT BEZEL, UPPER

- (1) Raise the headlights by using the pop-up switch.
Disconnect the negative (-) battery terminal.
- (2) Remove the headlight bezel, upper.

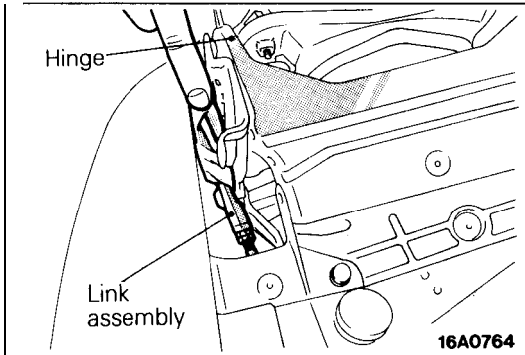

10. REMOVAL OF CONNECTOR BETWEEN LINK ASSEMBLY AND HINGE

Using a flat head screwdriver (wrap cloth or similar on the ball joint area to prevent injury), disconnect the connector.

NOTE

When disconnecting the line assembly from the hinge, hold the hinge by hand.

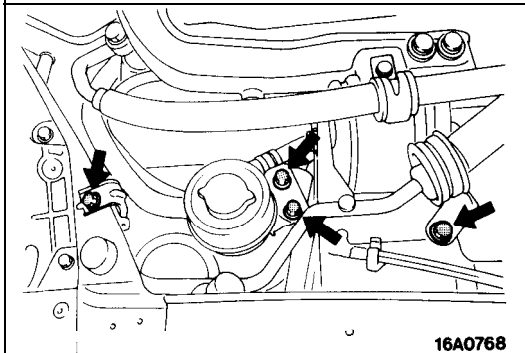

13. REMOVAL OF POWER STEERING OIL RESERVOIR MOUNTING BOLTS AND AIR CONDITIONER LIQUID PIPE CLAMP (Vehicles with air conditioner)

Remove bolts which mount the power steering oil reservoir and air conditioner liquid pipe clamp.

NOTE

Don't remove the return hose and pressure hose of the power steering oil reservoir.
Moreover, don't incline the oil reservoir.

INSPECTION

POP-UP MOTOR

Rotate the manual knob of the pop-up motor clockwise by hand to check continuity between terminals.

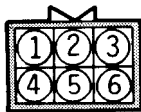

16A0833

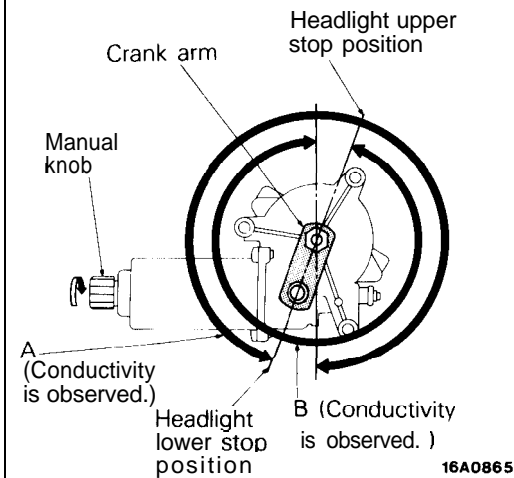

Terminal	Continuity range
When the (+) terminal of the ohmmeter is connected to ① and the (-) terminal is connected to ②	B
When the (+) terminal of the ohmmeter is connected to ① and the (-) terminal is connected to ⑤	A

NO8KHBK

REAR WIPER AND WASHER
CIRCUIT DIAGRAM

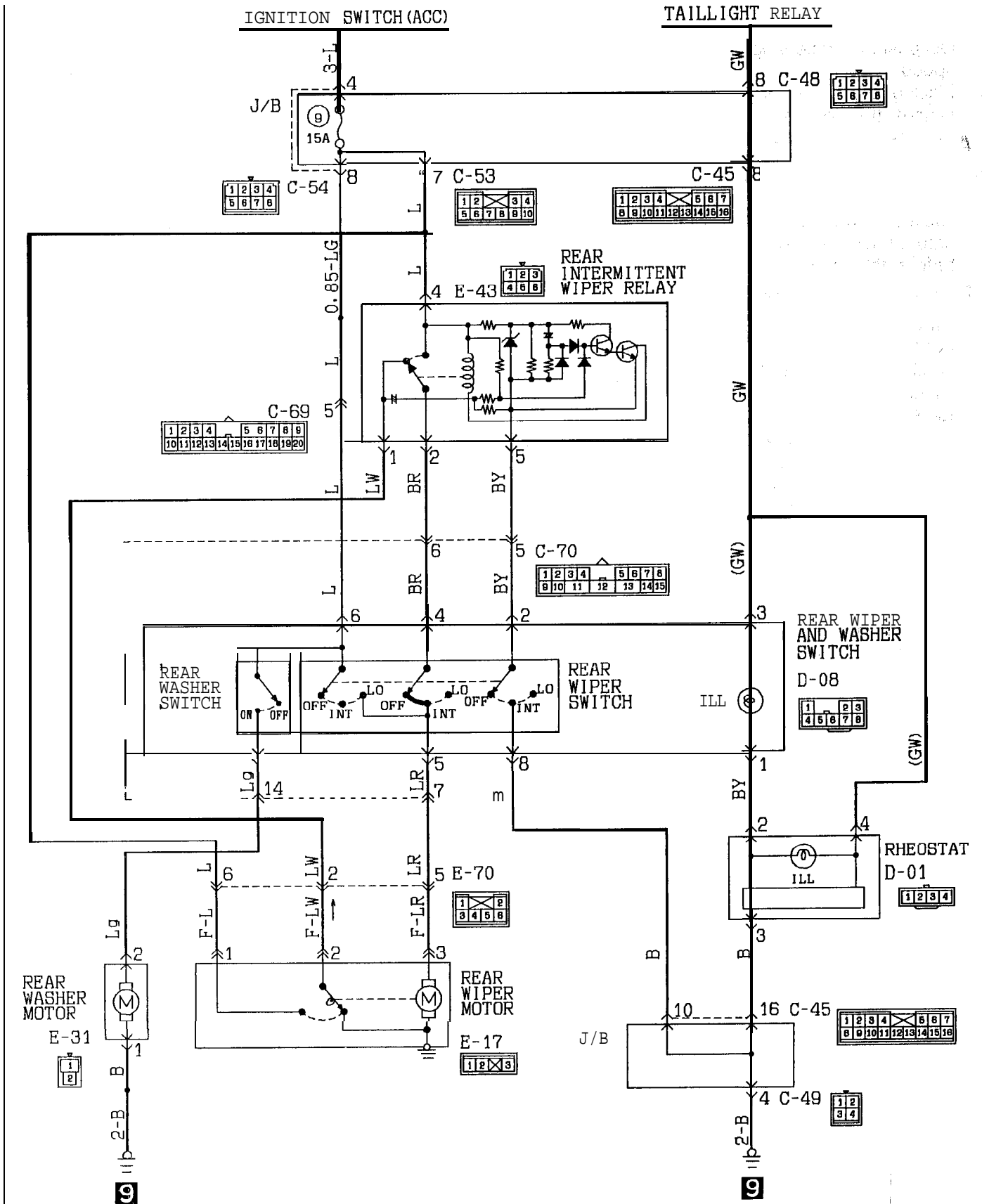

TROUBLESHOOTING
AUDIO CIRCUIT DIAGRAM

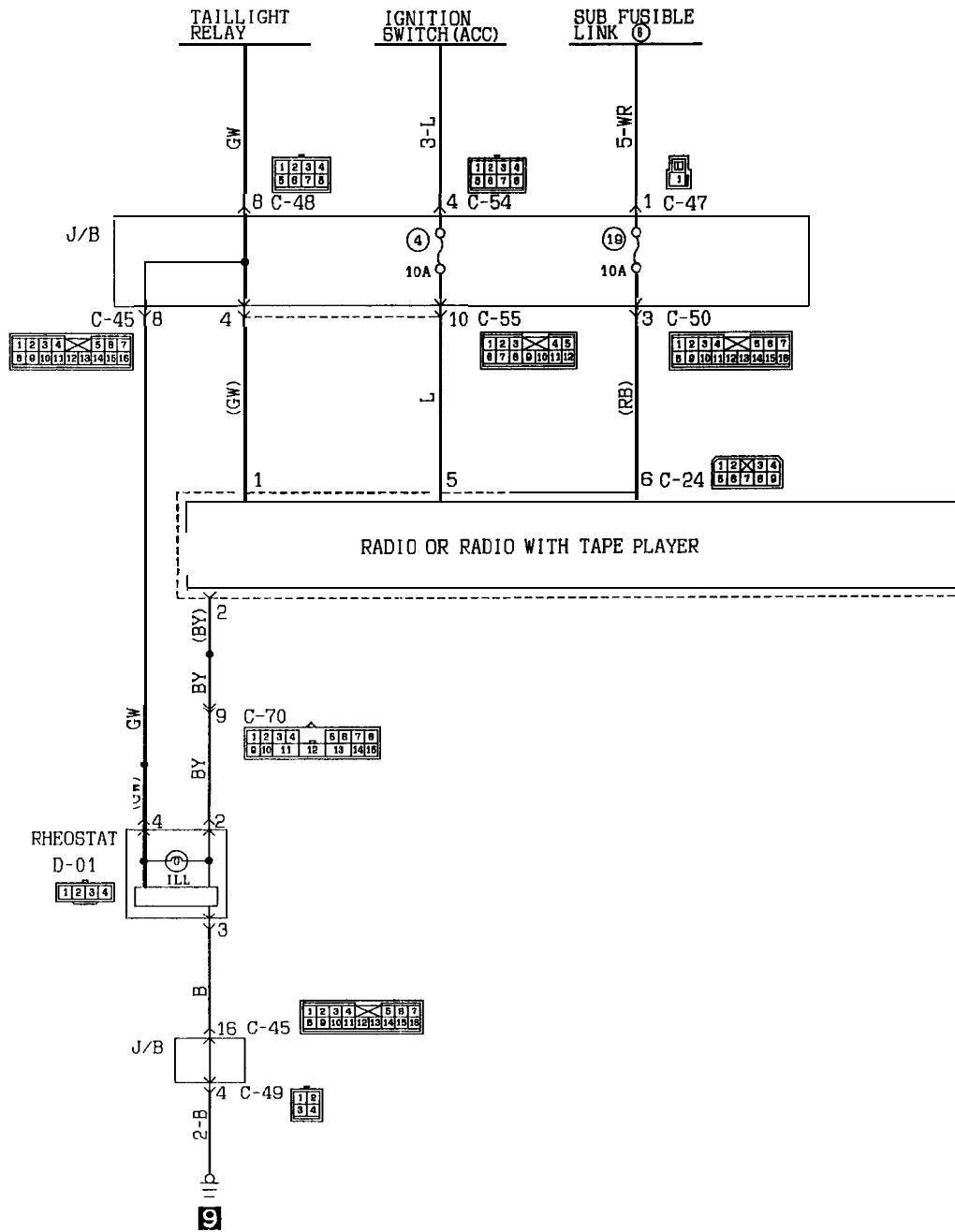

KX35-AC-U1407-NC

OPERATION

- When the radio power switch is turned on with the ignition switch at "ACC" or "ON", current flows through fuse No.4, radio, and ground, causing the radio to operate.
- Battery voltage is always supplied for use of the memory and other functions in the radio.

CLICK HERE TO **DOWNLOAD** THE COMPLETE MANUAL

- Thank you very much for reading the preview of the manual.
- You can download the complete manual from: www.heydownloads.com by clicking the link below



- Please note: If there is no response to CLICKING the link, please download this PDF first and then click on it.

CLICK HERE TO **DOWNLOAD** THE COMPLETE MANUAL