



**RALLIART**

# WORKSHOP MANUAL

Volume 1

## LANCER EVOLUTION-VII



Pub. No. S0105CT9A (1/2)

CLICK HERE TO **DOWNLOAD** THE COMPLETE MANUAL

- Thank you very much for reading the preview of the manual.
- You can download the complete manual from: [www.heydownloads.com](http://www.heydownloads.com) by clicking the link below



- Please note: If there is no response to CLICKING the link, please download this PDF first and then click on it.

CLICK HERE TO **DOWNLOAD** THE COMPLETE MANUAL

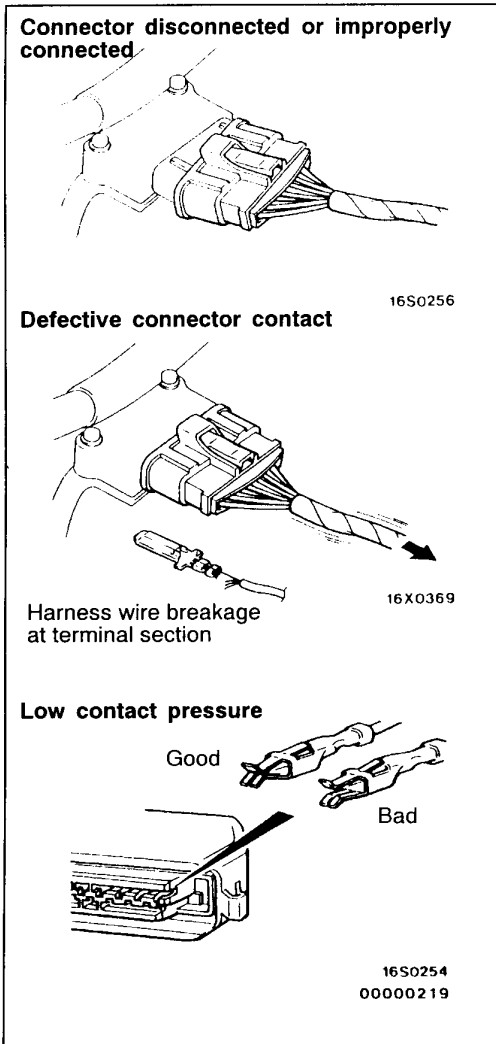

## CONNECTOR INSPECTION

### VISUAL INSPECTION

- Connector is disconnected or improperly connected
- Connector pins are pulled out
- Due to harness tension at terminal section
- Low contact pressure between male and female terminals
- Low connection pressure due to rusted terminals or foreign matter lodged in terminals

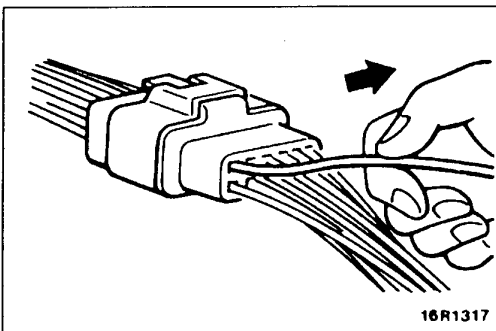

### CONNECTOR PIN INSPECTION

If the connector pin stopper is damaged, the terminal connections (male and female pins) will not be perfect even if the connector body is connected, and the pins may pull out of the reverse side of the connector. Therefore, gently pull the harnesses one by one to make sure that no pins pull out of the connector.

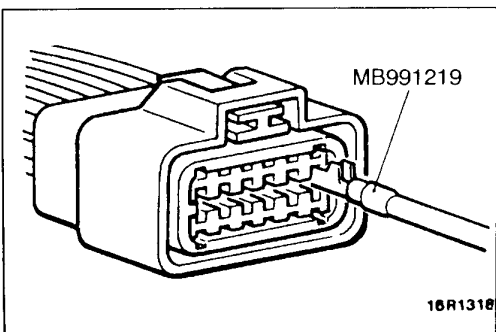

### CONNECTOR ENGAGEMENT INSPECTION

Use the special tool (connector pin connection pressure inspection harness of the inspection harness set) to inspect the engagement of the male pins and females pins. (Pin drawing force : 1 N or more)

**PLATE TYPE LIFT**

To avoid damaging the side sill garnish, put a wooden block between the side sill and a lift.

**NOTE**

The wooden block should be 100 mm wide and 50 mm high.

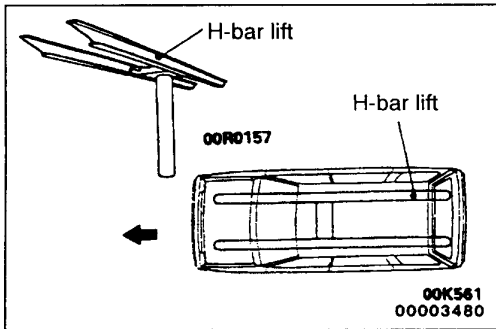

**SUPPORT POSITIONS AND SUPPORT METHOD FOR AN H-BAR LIFT**

**Caution**

When service procedures require removing the rear suspension, fuel tank, spare tyre and rear bumper, place additional weight on rear end of vehicle or anchor vehicle to hoist to prevent tipping of centre of gravity changes.

When H-bar lift is used to lift up vehicles, use of metallic attachment attached to the H-bar lift may cause damage to the suspension arm etc. Therefore, lift up the vehicle by the following procedure.

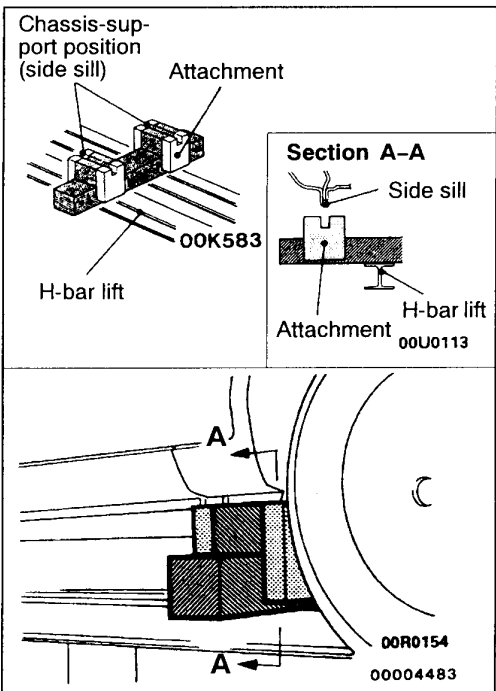

1. Place the vehicle on the H-bar lift (same direction).
2. Place attachments on the H-bar lift at the designated chassis-support positions. When making the attachments, refer to the section concerning making them.

**Caution**

If support is at any location other than the designated positions, the body or suspension might be deformed or otherwise damaged, so care should be taken to support only at the correct (designated) positions.

3. Raise the H-bar lift to the height at which the vehicle is slightly raised and check to be sure that the vehicle is correctly and sufficiently secured; then raise the vehicle.

12. Install the ignition coils and spark plugs.
13. Use the MUT-II to erase the self-diagnosis codes or disconnect the battery cable from the battery (-) terminal for 10 seconds or more and then reconnect the cable.

**NOTE**

This will erase the diagnosis code resulting from the crank angle sensor connector being disconnected.

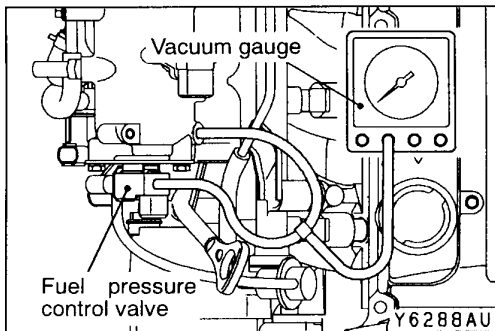
**MANIFOLD VACUUM CHECK**

1. Set the vehicle to the pre-inspection condition.
2. Turn the ignition switch to the "LOCK" (OFF) position.
3. Set the engine tachometer or connect the MUT-II.
4. Check that the idle speed is within the standard value.

**NOTE**

When using the MUT-II, select the code No.22.

5. Connect the three-way union joint to the vacuum hose between the fuel pressure control valve and the air intake plenum, and connect a vacuum gauge.
6. Check the manifold vacuum at idle.

**Limit: 58 kPa**

7. Turn the ignition switch to the "LOCK" (OFF) position.
8. Remove the vacuum gauge and install the vacuum hose in its original location.
9. Remove the engine tachometer or the MUT-II.

**LASH ADJUSTER CHECK**

If an abnormal noise (knocking) that seems to be coming from the lash adjuster is heard after starting the engine and does not stop, carry out the following check.

**NOTE**

- (1) The abnormal noise which is caused by a problem with the lash adjusters is generated after the engine is started, and will vary according to the engine speed. However, this noise is not related to the actual engine load.

Because of this, if the noise does not occur immediately after the engine is started, if it does not change in accordance with the engine speed, or if it changes in accordance with the engine load, the source of the noise is not the lash adjusters.

# CRANKSHAFT OIL SEAL

## REMOVAL AND INSTALLATION

### Caution

If the vehicle is equipped with the Brembo disc brake, during maintenance, take care not to contact the parts or tools to the caliper because the paint of caliper will be scratched.

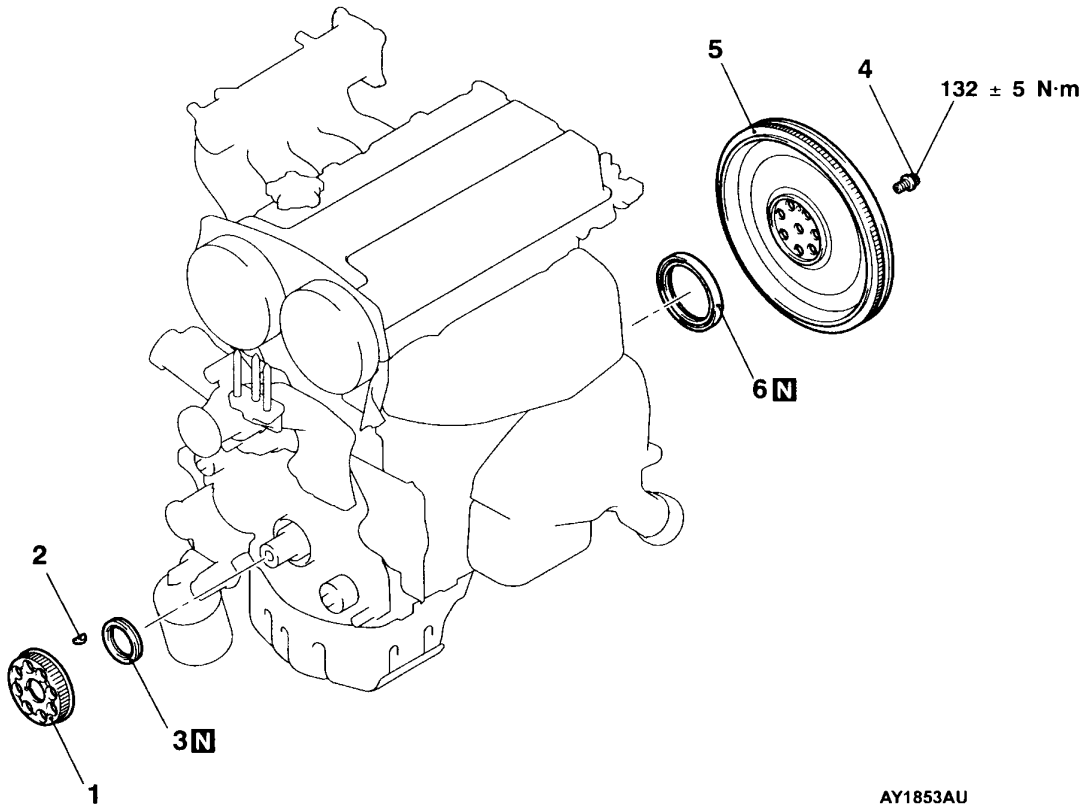
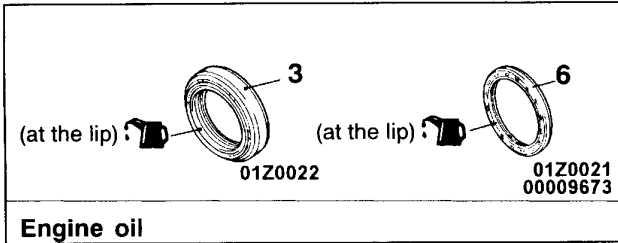

AY1853AU

### Crankshaft Front Oil Seal Removal Steps

- Timing belt and timing belt B (Refer to P.11A-34.)
- ▶D◀ 1. Crankshaft sprocket B
- ▶C◀ 2. Key
- ▶C◀ 3. Crankshaft front oil seal

### Crankshaft Rear Oil Seal Removal Steps

- Transfer assembly (Refer to GROUP 22A.)
- Transmission assembly (Refer to GROUP 22A.)
- Clutch cover, disc
- ◀A▶ ▶B◀ 4. Flywheel bolt
- ▶A◀ 5. Flywheel
- ▶A◀ 6. Crankshaft rear oil seal

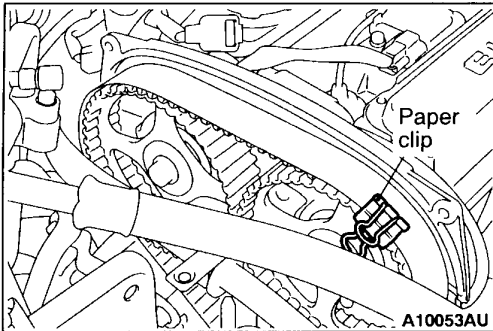

- (2) Hook the timing belt with exhaust side of the camshaft sprocket and retain the specified position indicated in the figure with paper clips.

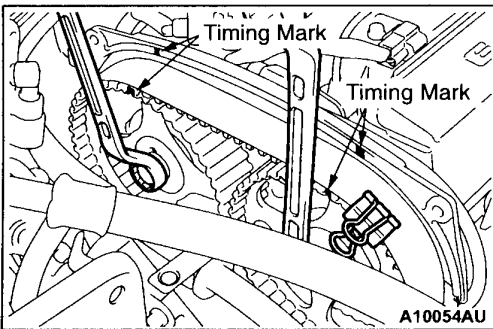

- (3) Use two wrenches to hook the timing belt to the intake side of the camshaft sprocket while aligning the timing marks on the rocker cover and camshaft sprocket.

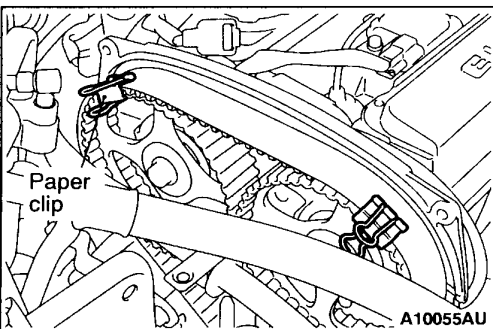

- (4) Retain timing belt at the specified positions with paper clips according to the figure.  
 (5) Hook the timing bolt to the tensioner pulley.  
 (6) Remove two paper clips.

#### Caution

After hooking the timing belt, apply force to the camshaft sprocket counterclockwise (in left turn) and reconfirm that each timing mark is in the proper position while the belt is being stretched.

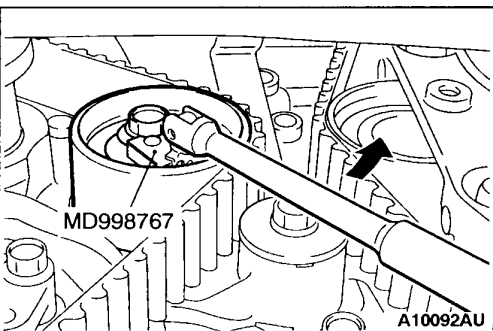

4. Use the special tool to rotate the tensioner pulley in the direction indicated in the figure, tighten the timing belt, and temporarily tighten the mounting bolt of the tensioner pulley for fixing.  
 5. Check that each timing mark is properly aligned.  
 6. Remove the screw driver and install a plug.  
 7. Adjust timing belt tension.

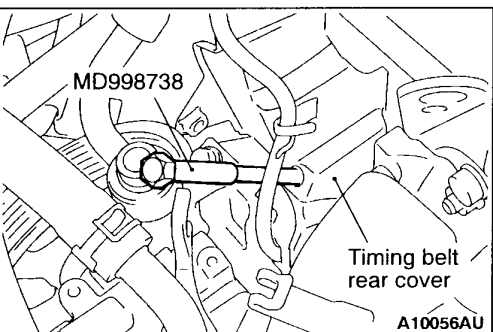

#### ▶◀ TIMING BELT TENSION ADJUSTMENT

1. After removal of the rubber plug of the timing belt rear cover, prepare the special tool to insert the special tool into the position where a wire or a pin inserted during installation of automatic tensioner can be moved easily.

#### Caution

Be sure to pressfit the special tool with a hand because pressfitting the special tool with tools, such as spanner, and etc. could damage a wire or a pin inserted into the automatic tensioner.

Items	Tightening torque N·m
Water outlet fitting bolt	10 ± 1
Thermostat housing bolt	23 ± 4
Water inlet pipe bolt (M6)	10 ± 1
Water inlet pipe bolt (M8)	13 ± 2
Water pump bolt	14 ± 1
Knock sensor	23 ± 2
Rocker arm, camshaft	
Cam position sensor bolt	8.8 ± 1.0
Cover bolt	10 ± 2
Cam position sensing cylinder bolt	22 ± 4
Cam position sensor support bolt	14 ± 1
Bearing cap bolt	20 ± 1
Oil delivery body bolt	11 ± 1
Cylinder head, valve	
Cylinder head bolt	78 ± 2 → Completely loosen → 20 ± 2 → 90° + 90°
Oil pump, oil pan	
Drain plug	39 ± 5
Oil pan bolt	9 ± 3
Oil screen bolt	19 ± 3
Baffle plate bolt	22 ± 4
Oil pressure switch	19 ± 3
Oil cooler bypass valve	54 ± 5
Relief plug	44 ± 5
Oil filter bracket bolt	19 ± 3
Plug cap	23 ± 3
Flange bolt	36 ± 3
Oil pump case bolt	23 ± 3
Oil pump cover bolt	17 ± 1
Oil pump cover screw	10 ± 2
Piston, connecting rod	
Connecting rod cap nut	20 ± 2 + 90° – 94°
Crankshaft, cylinder block	
Flywheel bolt	132 ± 5
Rear plate bolt	11 ± 1
Bell housing cover bolt	9 ± 1
Rear oil seal case bolt	11 ± 1
Beam bearing cap bolt	25 ± 2 + 90° – 100°
Check valve	32 ± 2
Throttle body	
Throttle position sensor bolt	2.0 ± 0.5
Turbocharger	
Waste gate actuator bolt	11.3 ± 1.5

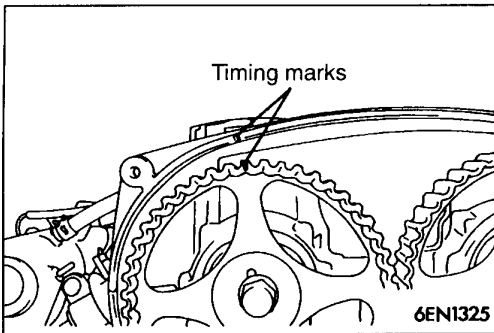

- Align the timing mark of the intake side camshaft sprocket to the timing mark on the rocker cover.

**NOTE**

Even when the sprocket and rocker cover timing marks are aligned, the intake camshaft will rotate slightly in the clockwise direction by the force of the valve spring and will stabilize.

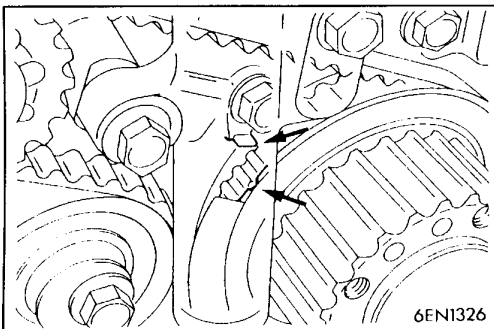

- Shift and set the crankshaft sprocket timing mark by one tooth in the counterclockwise direction in the same manner as the exhaust side camshaft sprocket.

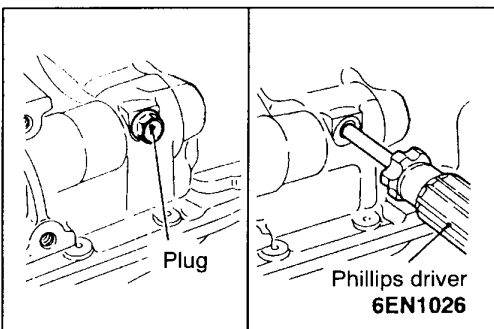

- Align the oil pump sprocket timing marks.
- When aligning the oil pump sprocket timing marks, remove the cylinder block plug, and insert an 8 mm shaft diameter Phillips driver into the plug hole, and confirm that the driver shaft can be inserted by 60 mm or more. Do not remove the Phillips driver until the timing belt has been attached. If the driver shaft contacts the silent shaft and only enters 20 to 25 mm, rotate the sprocket once, align the timing marks again, and then confirm that the Phillips driver can be inserted by 60 mm or more.

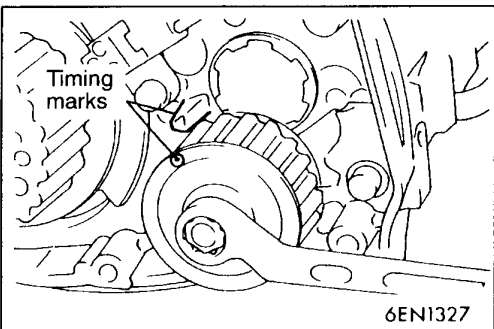

- Remove the Phillips driver, and set the oil pump sprocket at a position returned by one tooth in the counterclockwise direction.

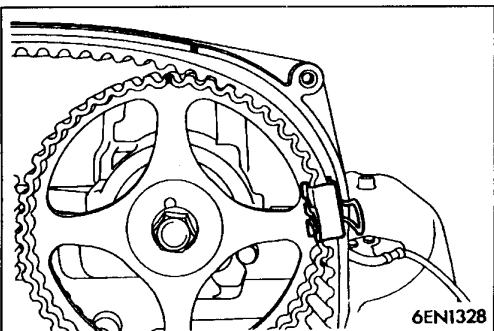

- Attach the timing belt to the exhaust side camshaft sprocket, and fix with a paper clip at the position shown in the illustration.

**REMOVAL SERVICE POINT****◀A▶ LASH ADJUSTER REMOVAL****Caution**

When reusing the lash adjuster, always clean and inspect it before installing. (Refer to the section on checking the lash adjuster.)

**INSTALLATION SERVICE POINTS****▶A◀ LASH ADJUSTER INSTALLATION****Caution**

When reusing the lash adjuster, always clean and inspect it before installing. (Refer to the section on checking the lash adjuster.)

Assembly the lash adjuster onto the rocker arm while taking care not to spill out diesel oil in it.

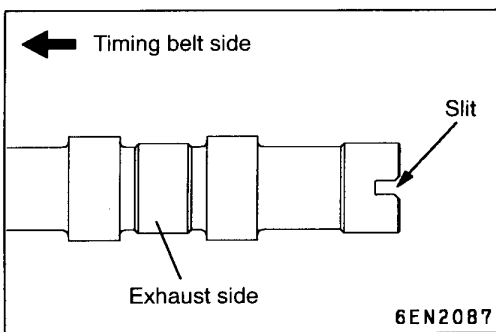
**▶B◀ CAMSHAFT INSTALLATION**

1. Apply engine oil on the camshaft journal and cam.
2. Install the camshaft onto the cylinder head.

**Caution**

Do not mistake the intake and exhaust camshafts. There is a 4 mm width slit on the back end of the exhaust side camshaft.

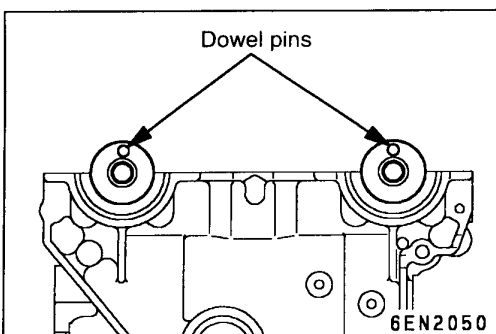
**▶C◀ BEARING CAP INSTALLATION**

1. Set the camshaft's dowel pin to the approximate top.

2. The bearing caps No. 2 to 5 have the same shape. Check the identification symbol before installing to prevent mistaking the cap No., intake side and exhaust side.

**Identification symbol**

(Stamped on front and on No. 2 to 5 bearing caps)

I : Intake side

E : Exhaust side

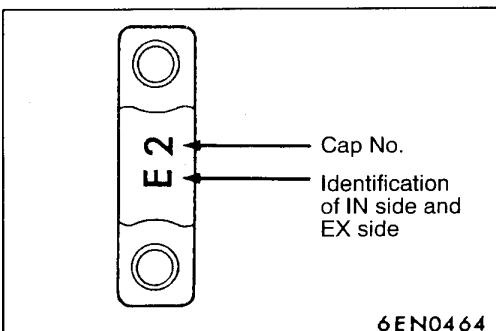

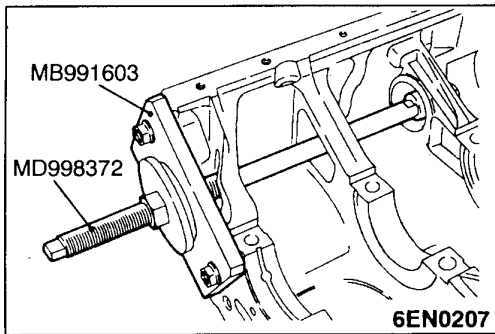

### ◀E▶ COUNTER BALANCE SHAFT REAR BEARING REMOVAL

1. Pull out the counter balance shaft rear bearing right from the cylinder block using the special tool (MD998372).
2. When removing the counter balance shaft rear bearing left, install the special tool (MB991603) onto the front of the cylinder block, and then remove the bearing using the special tool (MD998372).

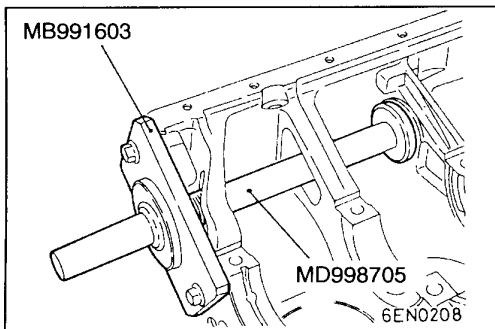

### INSTALLATION SERVICE POINTS

#### ▶A▶ COUNTER BALANCE SHAFT REAR BEARING LEFT INSTALLATION

1. Install the special tool (MB991603) onto the cylinder block.
2. Set the counter balance shaft rear bearing left into the special tool (MD998705).

#### NOTE

There is no oil hole on the counter balance shaft rear bearing left.

3. Tap in the counter balance shaft rear bearing left.

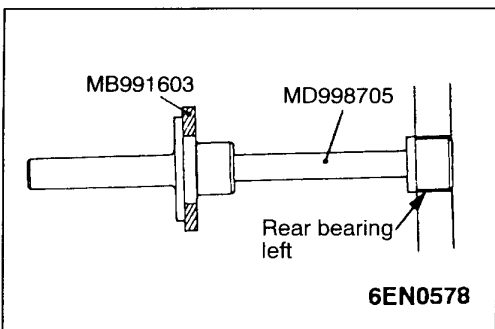

#### ▶B▶ COUNTER BALANCE SHAFT REAR BEARING RIGHT INSTALLATION

1. Install the guide pin onto the cylinder block.

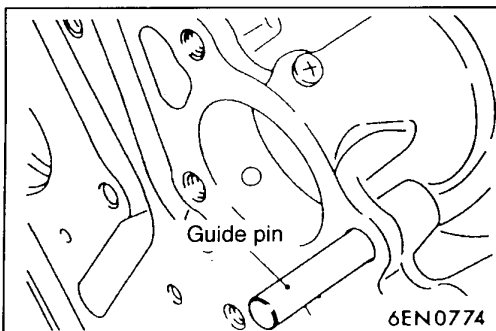

2. Align the ratchet ball of the special tool with the oil hole, and set the counter balance shaft rear bearing right.

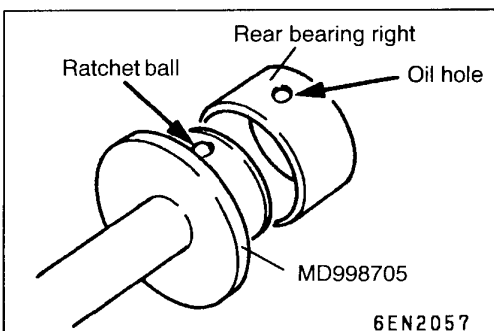

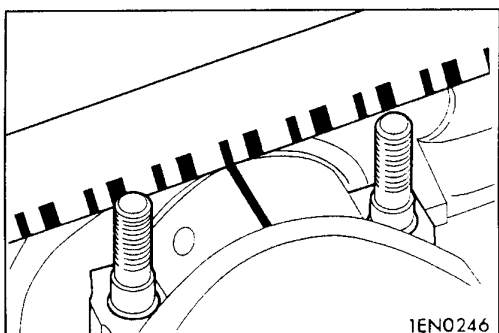

## 2. CRANKSHAFT PIN OIL CLEARANCE (PLASTIC GAUGE METHOD)

- (1) Wipe off the oil from the crankshaft pin and connecting rod bearing.
- (2) Set a plastic gauge as long as the bearing width on the pin shaft so that straightly aligned with the shaft centre.
- (3) Carefully set the connecting rod cap, and tighten the nut at the specified torque  $20 \pm 2 \text{ N}\cdot\text{m} + 90^\circ$  to  $94^\circ$ .
- (4) Remove the nut, and carefully remove the connecting rod cap.
- (5) Measure the width of the crushed plastic gauge (at the section crushed the most) with the scale printed on the plastic gauge bag.

**Standard value: 0.03 – 0.05 mm**

**Limit value: 0.1 mm**

# FUEL

## CONTENTS

MULTIPOINT FUEL INJECTION (MPI) .....	13A
FUEL SUPPLY .....	13B

---

Code No. P0105 Barometric pressure sensor system	Probable cause
<p>Inspection Range</p> <ul style="list-style-type: none"> <li>• 2 seconds after the ignition switch is set to the "ON" position, or after the completion of start of engine.</li> </ul> <p>Evaluation Conditions</p> <ul style="list-style-type: none"> <li>• The sensor output voltage is more than 4.5 V for 4 seconds (Equivalent to air pressure of more than 114 kPa)</li> </ul> <p>or</p> <ul style="list-style-type: none"> <li>• The sensor output voltage is less than 0.2 V for 4 seconds (Equivalent to air pressure of less than 5 kPa)</li> </ul>	<ul style="list-style-type: none"> <li>• Barometric pressure sensor malfunction</li> <li>• Barometric pressure sensor circuit disconnection, short-circuit, or connector contact defect</li> <li>• Engine-ECU malfunction</li> </ul>

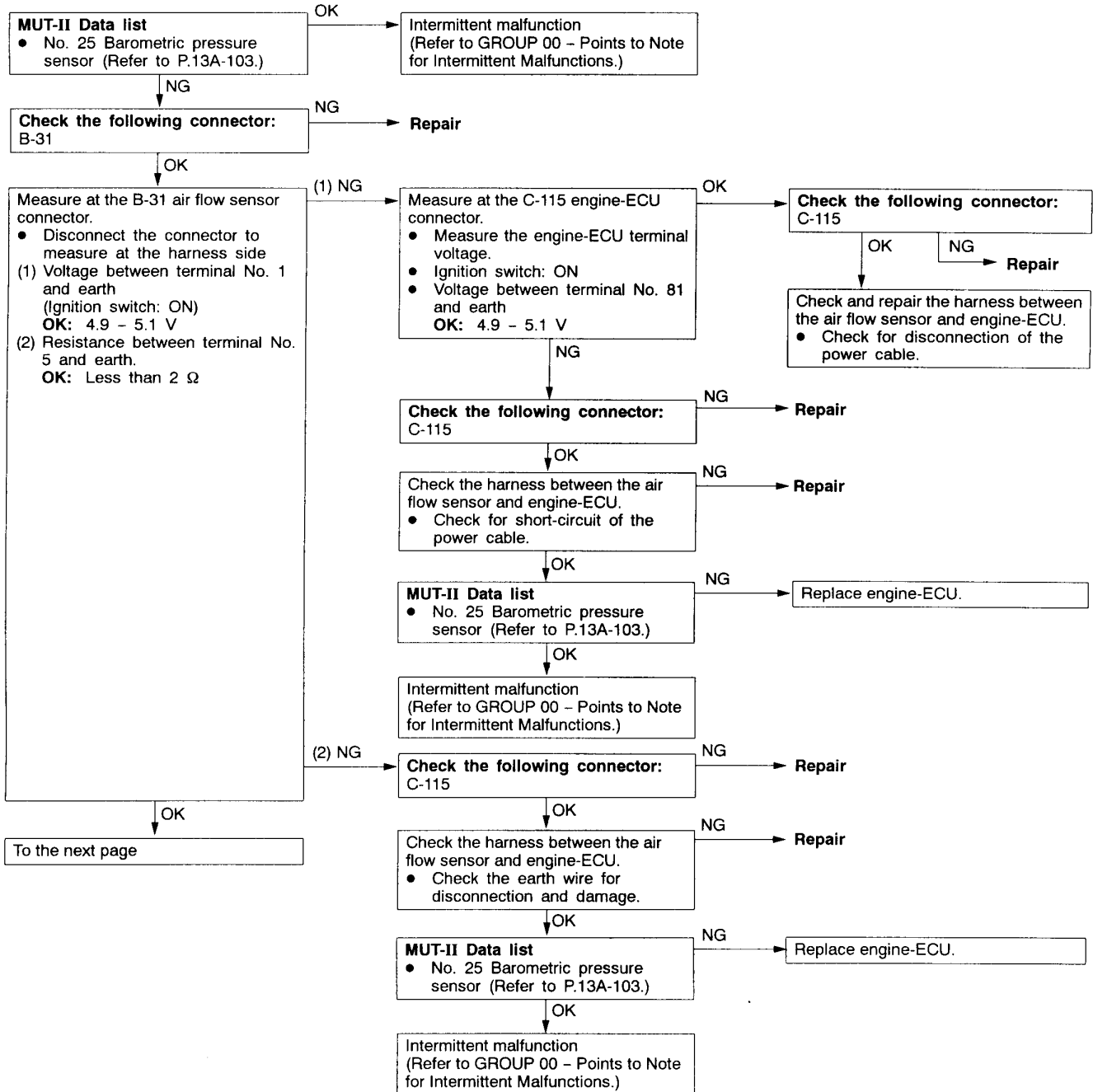

Code No. P0141 Oxygen sensor heater (rear) system	Probable cause
<p>Inspection Range</p> <ul style="list-style-type: none"> <li>• The engine coolant water temperature is approximately more than 20°C.</li> <li>• The oxygen sensor heater (rear) is ON.</li> <li>• The engine speed is more than 50 r/min.</li> <li>• A/C relay: OFF, radiator fan: OFF</li> <li>• The battery voltage is 11 – 16 V.</li> </ul> <p>Evaluation Conditions</p> <ul style="list-style-type: none"> <li>• The oxygen sensor heater (rear) current is less than 0.2 A or more than 3.5 A for 4 seconds.</li> </ul>	<ul style="list-style-type: none"> <li>• Oxygen sensor heater (rear) malfunction</li> <li>• Oxygen sensor heater (rear) circuit disconnection, short-circuit, or connector contact defect</li> <li>• Engine-ECU malfunction</li> </ul>

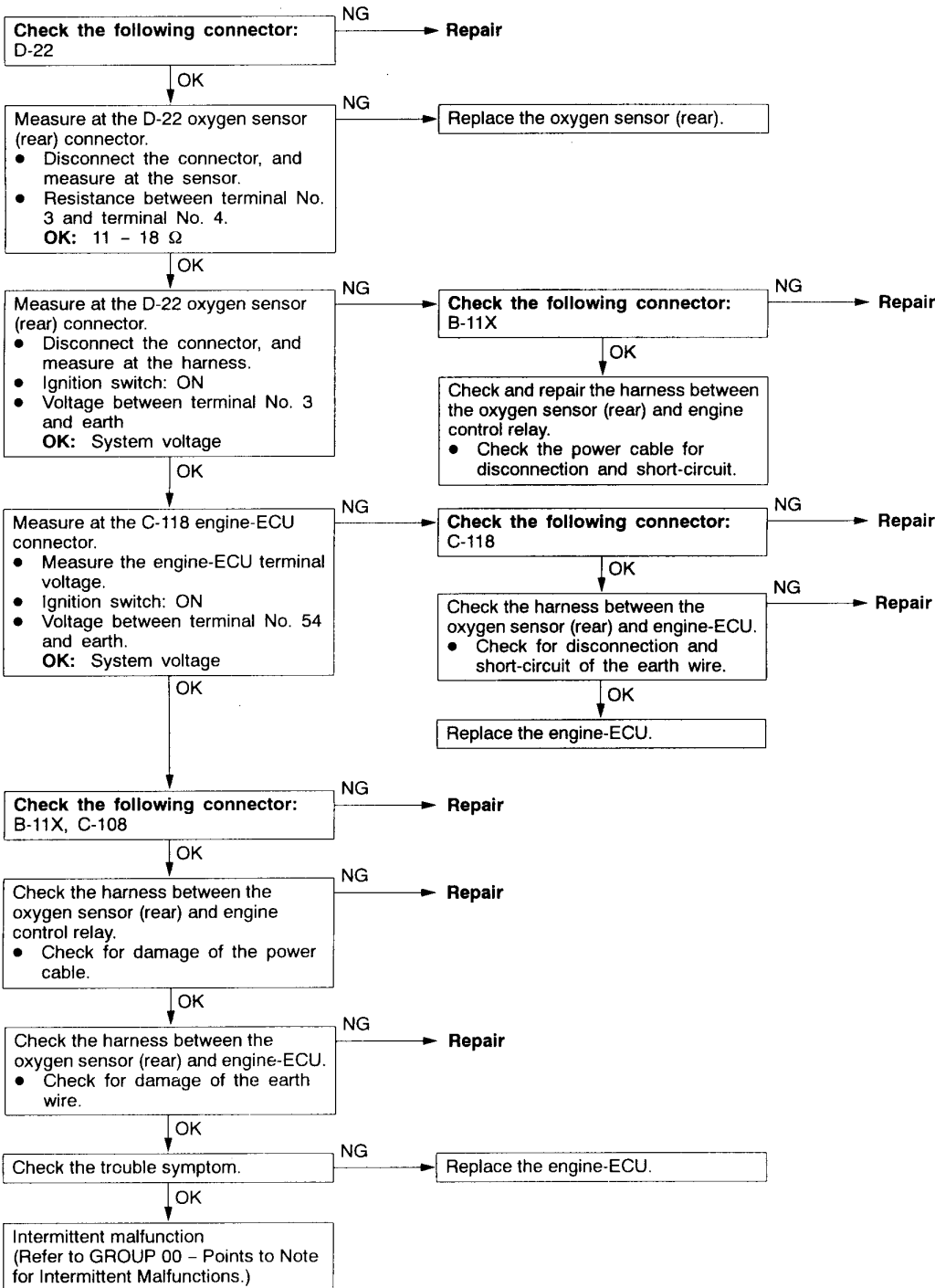

Code No. P0500 Vehicle speed sensor system	Probable cause
<p>Inspection Range</p> <ul style="list-style-type: none"> <li>Ignition switch: ON</li> <li>After 2 seconds from setting ignition switch to ON position or completion of engine starting</li> <li>The engine speed is approximately 2,000 – 4,000 r/min or more.</li> <li>The volumetric efficiency is 60 – 80%.</li> </ul> <p>Evaluation Conditions</p> <ul style="list-style-type: none"> <li>Vehicle speed signal does not change for 2 seconds. (Pulse signal is not input.)</li> </ul>	<ul style="list-style-type: none"> <li>Vehicle speed sensor malfunction</li> <li>Vehicle speed sensor circuit disconnection, short-circuit, or connector contact defect</li> <li>Engine-ECU malfunction</li> </ul>

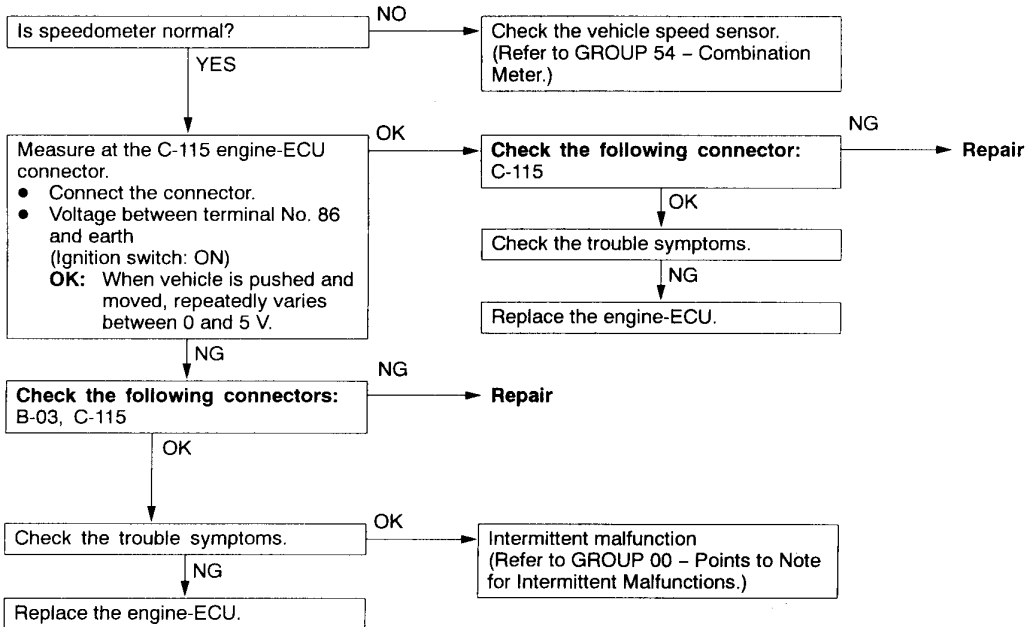

Inspection Procedure 4

Engine warning lamp stays illuminated and does not turn OFF.	Probable cause
The engine-ECU illuminates the engine warning lamp when the occurrence of a diagnosis code is recorded.	<ul style="list-style-type: none"> <li>Engine-ECU malfunction</li> </ul>

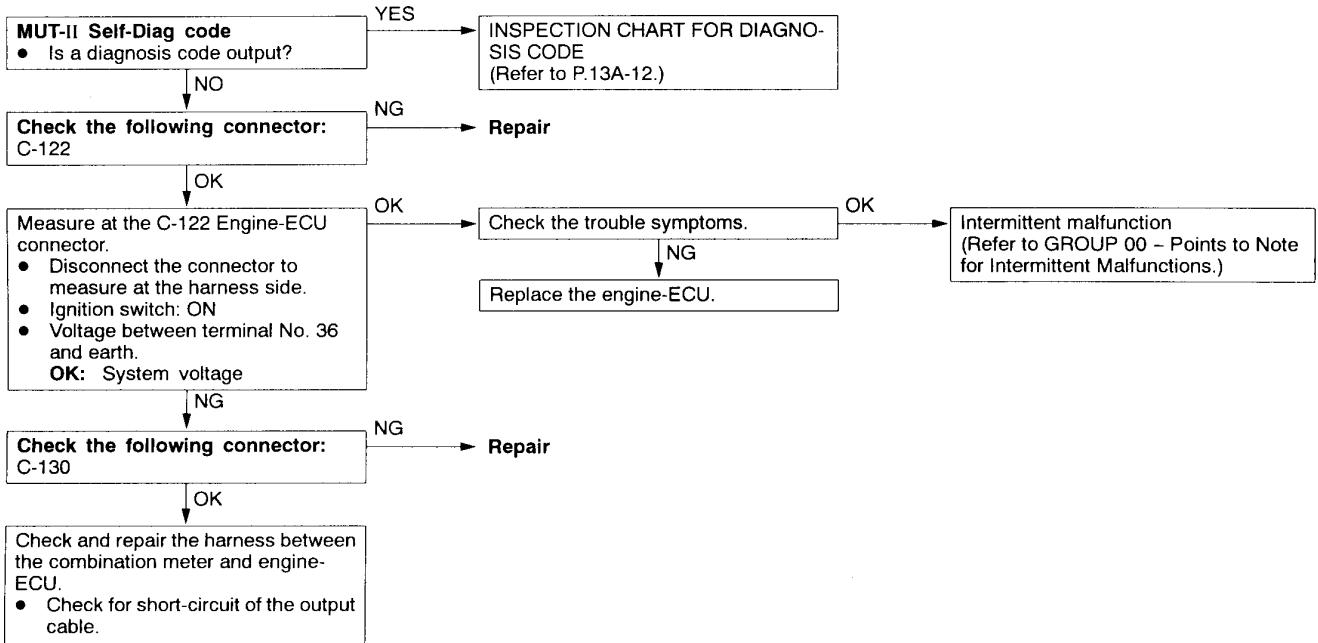

**Inspection Procedure 13**

Shock during deceleration	Probable cause
The idle speed control may be incorrect.	<ul style="list-style-type: none"> <li>Idle speed control system malfunction</li> </ul>

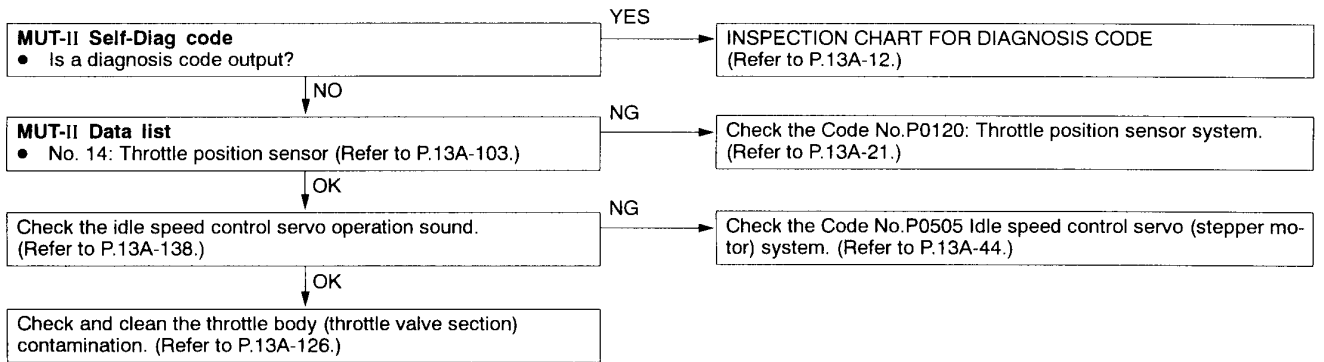

Inspection Procedure 23

Fuel pump system	Probable cause
<ul style="list-style-type: none"> <li>The engine-ECU turns the fuel pump relay ON during cranking and engine operation, and supplies the drive power to the fuel pump.</li> <li>When operating with a low load, the engine-ECU supplies power to the fuel pump via the resistor. When operating with a high load, power is directly supplied and the fuel pump fuel discharge amount is increased.</li> </ul>	<ul style="list-style-type: none"> <li>Fuel pump relay 1 malfunction</li> <li>Fuel pump relay 2 malfunction</li> <li>Fuel pump relay 3 malfunction</li> <li>Fuel pump resistor malfunction</li> <li>Fuel pump malfunction</li> <li>Fuel pump circuit disconnection, short-circuit, or connector contact defect</li> <li>Engine-ECU malfunction</li> </ul>

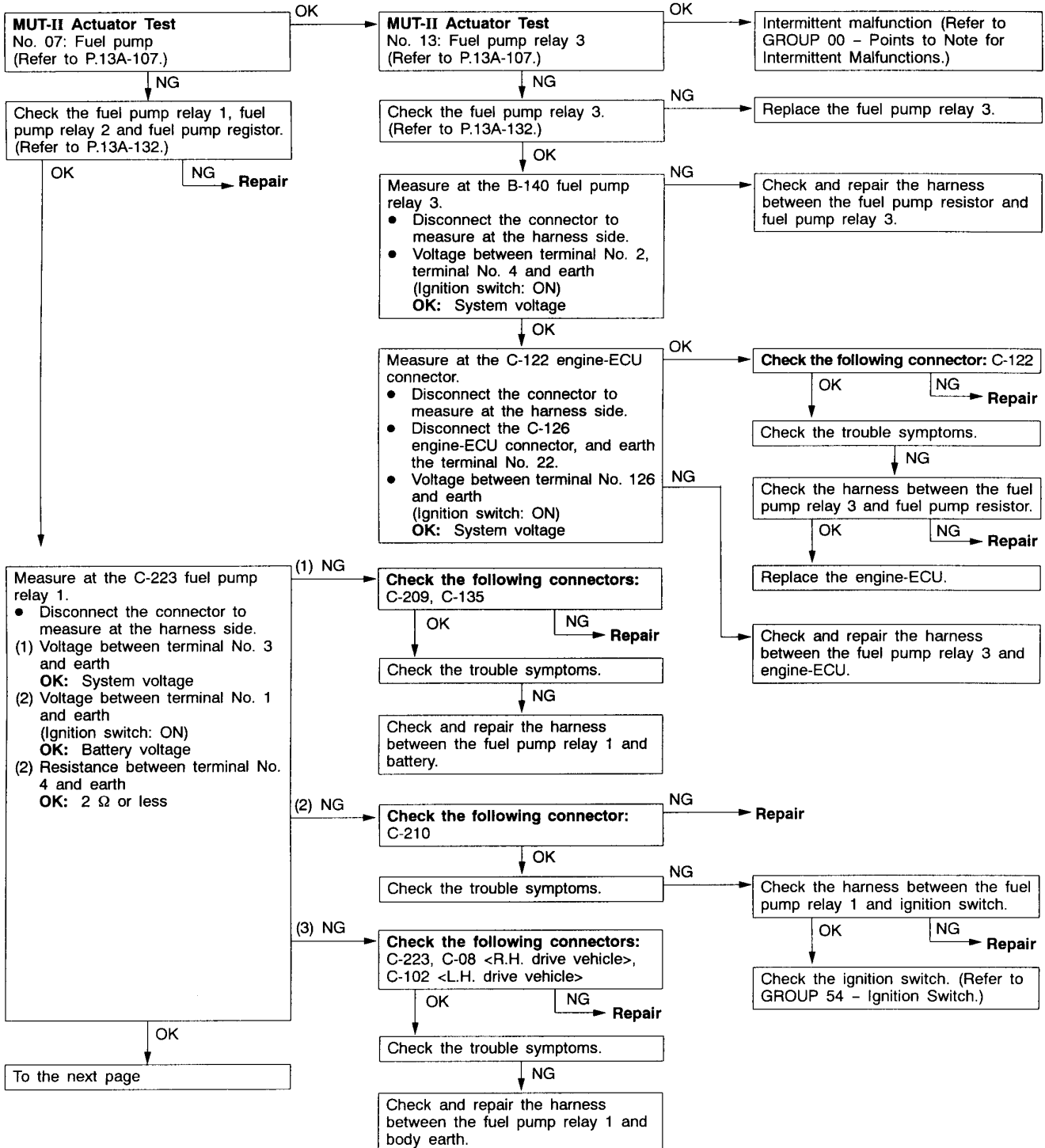

Inspection Procedure 31

Intercooler water spray lamp system	Probable cause
The engine-ECU illuminates the intercooler water spray lamp when the intercooler water spray switch (automatic) is ON.	<ul style="list-style-type: none"> <li>● Intercooler water spray lamp bulb dead</li> <li>● Ignition switch malfunction</li> <li>● Intercooler water spray lamp circuit disconnection, short-circuit, or connector contact defect</li> <li>● Intercooler water spray switch circuit disconnection, short-circuit, or connector contact defect</li> <li>● Engine-ECU malfunction</li> </ul>

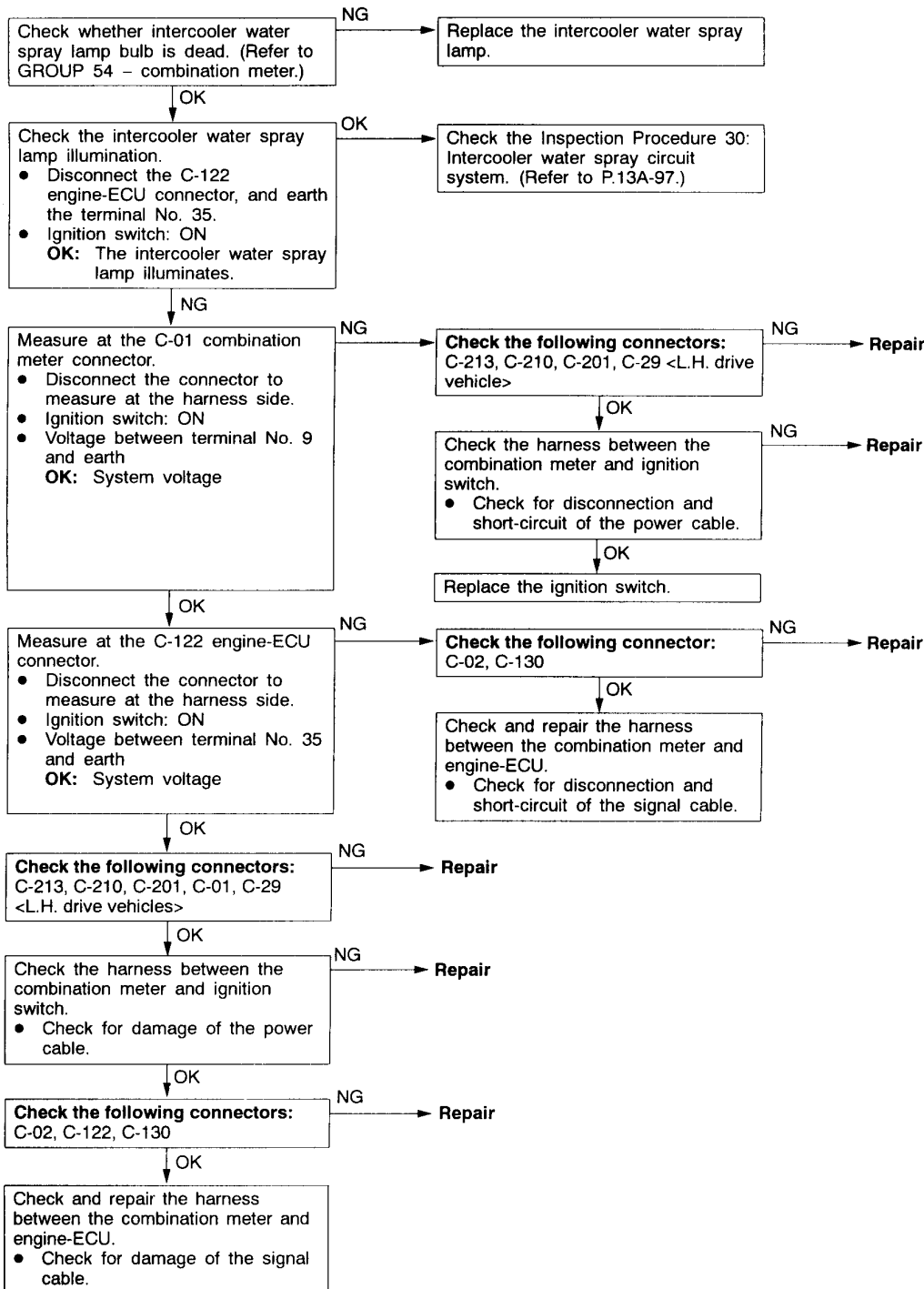

Terminal No.	Check item	Check condition (Engine condition)	Normal condition
86	Vehicle speed sensor	<ul style="list-style-type: none"> <li>● Ignition switch: "ON"</li> <li>● Move the vehicle slowly forward</li> </ul>	0 ↔ 5 V (Changes repeatedly)
88	Camshaft position sensor	Engine: Cranking	0.4 – 3.0 V
		Engine: Idle operation	0.5 – 2.0 V
89	Crank angle sensor	Engine: Cranking	0.4 – 4.0 V
		Engine: Idle operation	1.5 – 2.5 V
90	Air flow sensor	Engine: Idle operation	2.2 – 3.2 V
		Engine speed: 2,500 r/min	
91	Intercooler water spray switch (Manual)	<ul style="list-style-type: none"> <li>● Ignition switch: "ON"</li> <li>● Intercooler water spray switch: ON</li> </ul>	1 V or less
		<ul style="list-style-type: none"> <li>● Ignition switch: "ON"</li> <li>● Intercooler water spray switch: OFF</li> </ul>	System voltage

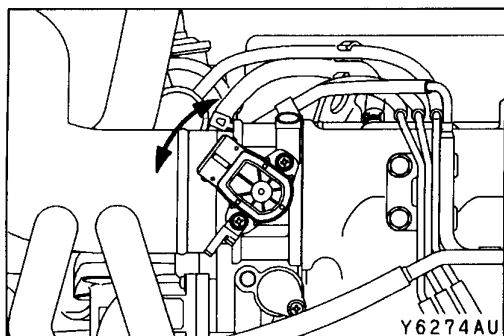

4. If not within the standard value, loosen the throttle position sensor mounting bolts. Then rotate the sensor body to adjust.
5. Turn the ignition switch to "LOCK" (OFF) position.
6. Remove the MUT-II. If the MUT-II is not used, remove the special tool, and then connect the throttle position sensor connector.
7. If a diagnosis code is displayed, erase the diagnosis code by using the MUT-II or disconnect the negative battery cable from the battery terminal and then leave it for at least ten seconds. After that, reconnect the battery cable, and then let the engine run at idle for approximately 10 minutes.

## BASIC IDLE SPEED ADJUSTMENT

### NOTE

- (1) The basic idling speed has been adjusted by the speed adjusting screw by the manufacturer, and there should usually be no need for readjustment.
  - (2) If the adjustment has been changed by mistake, the idle speed may become too high or the idle speed may drop too low when loads from components such as the A/C are placed on the engine. If this occurs, adjust by the following procedure.
  - (3) The adjustment, if made, should be made after first confirming that the spark plugs, the injectors, the idle speed control servo, the compression pressure, etc., are all normal.
1. Before inspection and adjustment, set the vehicle to the pre-inspection condition.
  2. Connect the MUT-II to the diagnosis connector (16-pin).

### NOTE

When the MUT-II is connected, the diagnosis control terminal should be earthed.

3. Start the engine and run at idle.
4. Select the item No. 30 of the MUT-II Actuator test.

### NOTE

This holds the idle speed control servo at the basic step to adjust the basic idle speed.

5. Check the basic idle speed.

**Standard value: 850 ± 100 r/min**

### NOTE

- (1) The engine speed may be 20 to 100 r/min lower than indicated above for a new vehicle [driven approximately 500 km or less], but no adjustment is necessary.
- (2) If the engine stalls or the engine speed is low even though the vehicle has been driven approximately 500 km or more, it is probable that deposits are adhered to the throttle valve, so clean it. (Refer to P.13A-126.)

# INJECTOR

## REMOVAL AND INSTALLATION

**Pre-removal and Post-installation Operation**

- Fuel Discharge Prevention (Refer to P.13A-125.)
- Strut Tower Bar Removal and Installation (Refer to GROUP 42.)
- Air Hose E, Air By-pass Hose, Air Pipe C Removal and Installation (Refer to GROUP 15 – Intercooler.)
- Fuel Leakage Check

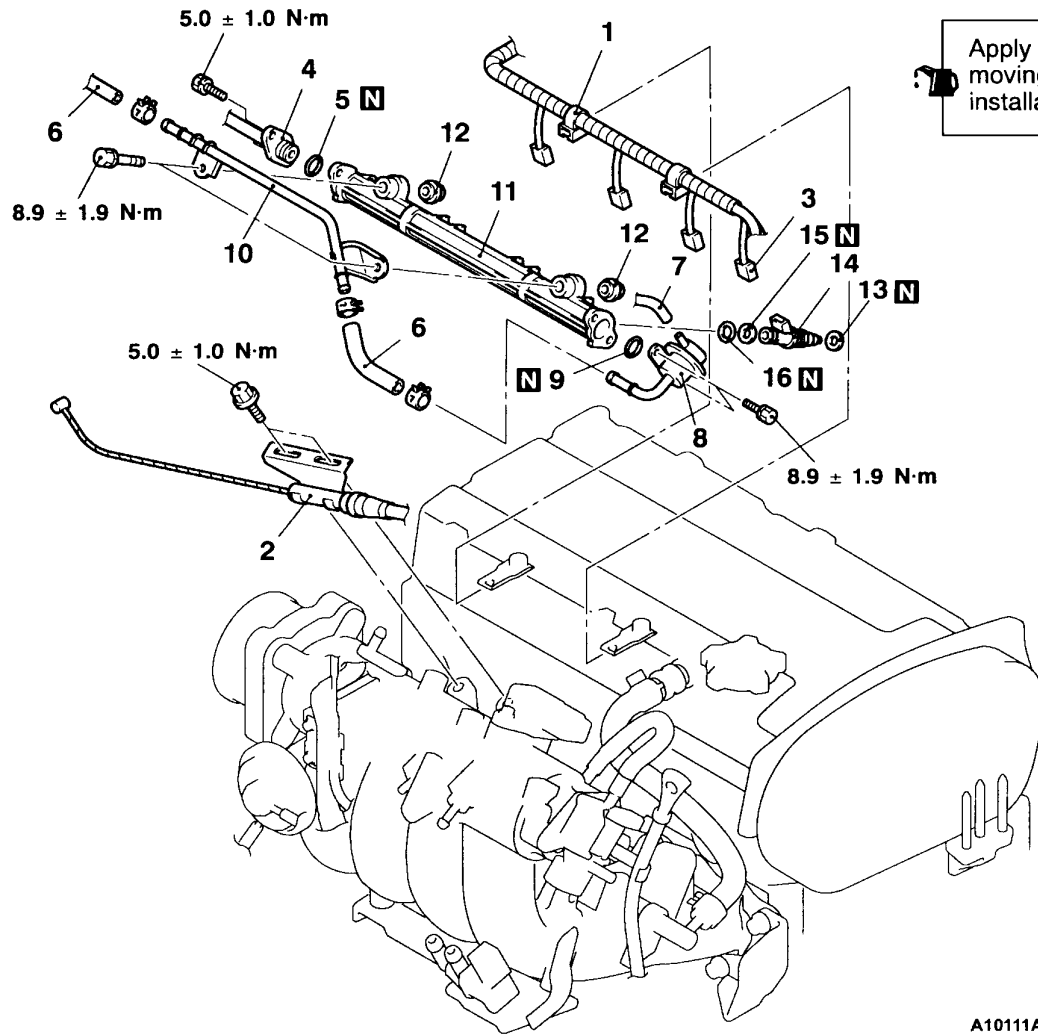

A10111AU

**Removal steps**

- |  |  |   |
|--|--|---|
| <ul style="list-style-type: none"> <li>▶◀ 4. High-pressure fuel hose connection</li> <li>▶◀ 6. Fuel return hose connection</li> <li>▶◀ 8. Fuel pressure regulator</li> </ul> | <ul style="list-style-type: none"> <li>◀▶ 1. Control harness connector</li> <li>2. Accelerator cable assembly connection (Throttle body side)</li> <li>3. Injector harness connector</li> <li>5. O-ring</li> <li>7. Vacuum sensor connector</li> </ul> | <ul style="list-style-type: none"> <li>9. O-ring</li> <li>10. Fuel return pipe</li> <li>11. Delivery pipe</li> <li>12. Insulator</li> <li>13. Insulator</li> <li>14. Injector</li> <li>15. Grommet</li> <li>16. O-ring</li> </ul> |
|--|--|---|

<PIPE AND GAUGE ASSEMBLY>

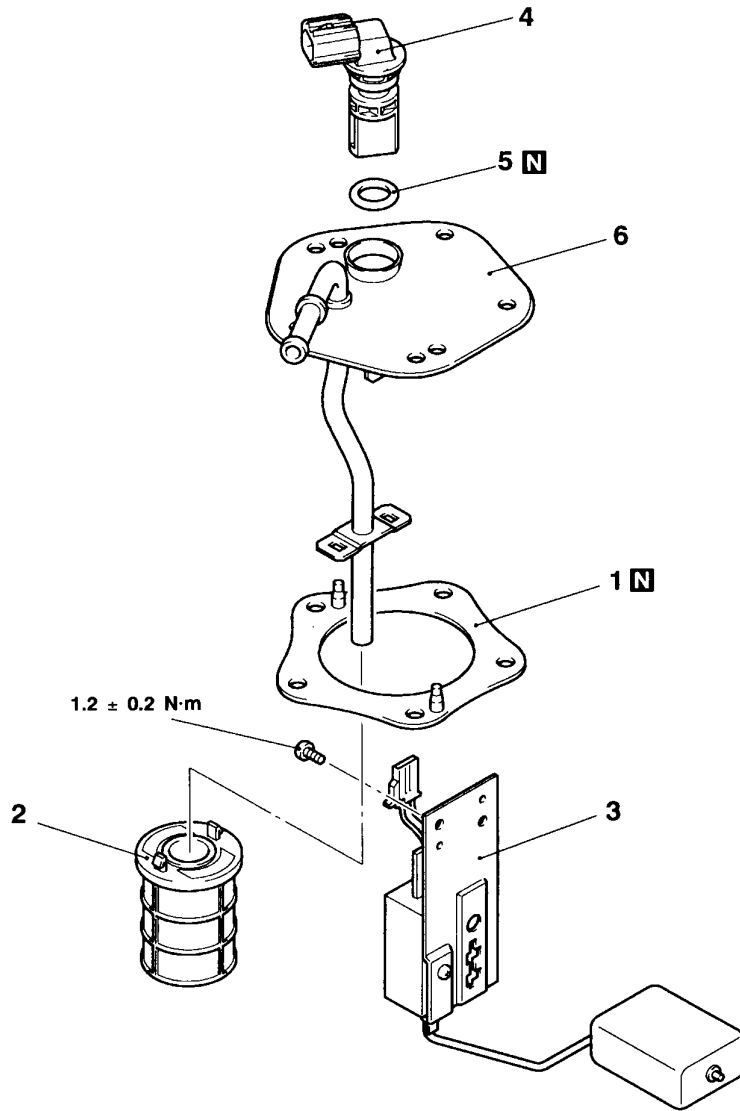

AY2152AU

**Removal steps**

1. Packing
2. Filter
3. Gauge unit

- ▶A◀
4. Connector
  5. O-ring
  6. Pipe assembly

**INSTALLATION SERVICE POINT**

▶A◀ **O-RING/GROMMET INSTALLATION**

Apply a fuel O-ring and grommet before installing them, to prevent them from being damaged or twisted.

# WATER HOSE AND WATER PIPE

## REMOVAL AND INSTALLATION

**Pre-removal and Post-installation Operation**

- Engine Coolant Draining and Supplying (Refer to P.14-6.)
- Air Cleaner Assembly Removal and Installation (Refer to GROUP 15 – Air Cleaner.)
- Air Bypass Valve Assembly, Air Bypass Hose, Air Hose E and Air Pipe C, Air Hose D Removal and Installation (Refer to GROUP 15 – Intercooler.)
- Secondary Air Control Valve Bracket Removal and Installation (Refer to GROUP 15 – Secondary Air Supply System.)
- Battery, Battery Tray Removal and Installation

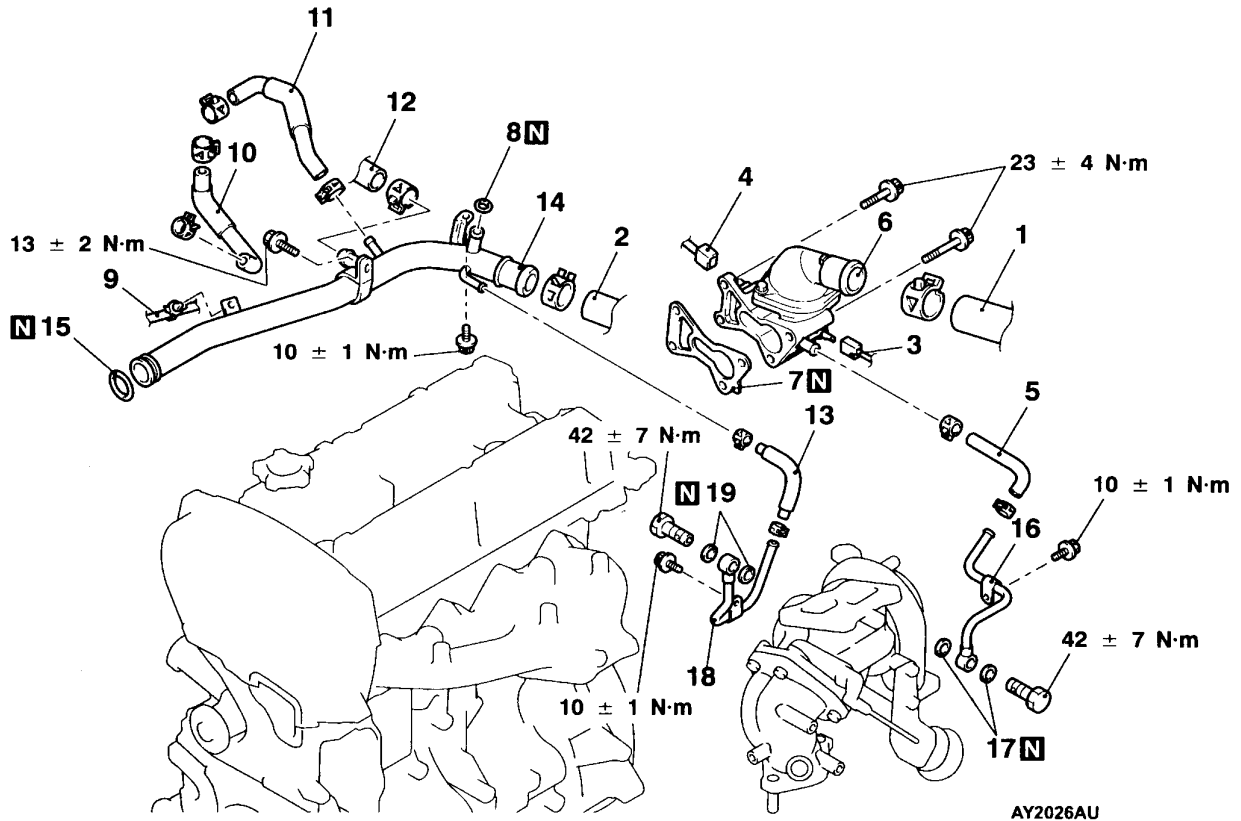

AY2026AU

**Removal steps**



1. Radiator upper hose connection
2. Radiator lower hose connection
3. Engine coolant temperature gauge unit connector
4. Engine coolant temperature sensor connector
5. Water hose
6. Water outlet fitting and thermostat case assembly
7. Thermostat case gasket
- ▶A◀ 8. O-ring
9. Detonation sensor connection
10. Water hose



11. Water hose
12. Heater hose connection
13. Water hose
- ▶B◀ 14. Water inlet pipe
- ▶A◀ 15. O-ring
16. Turbocharger water feed pipe
17. Gasket
  - Turbocharger assembly (Refer to GROUP 15.)
18. Turbocharger water return pipe
19. Gasket

<WATER SPRAY NOZZLE/WATER SPRAY HOSE/WASHER TANK>

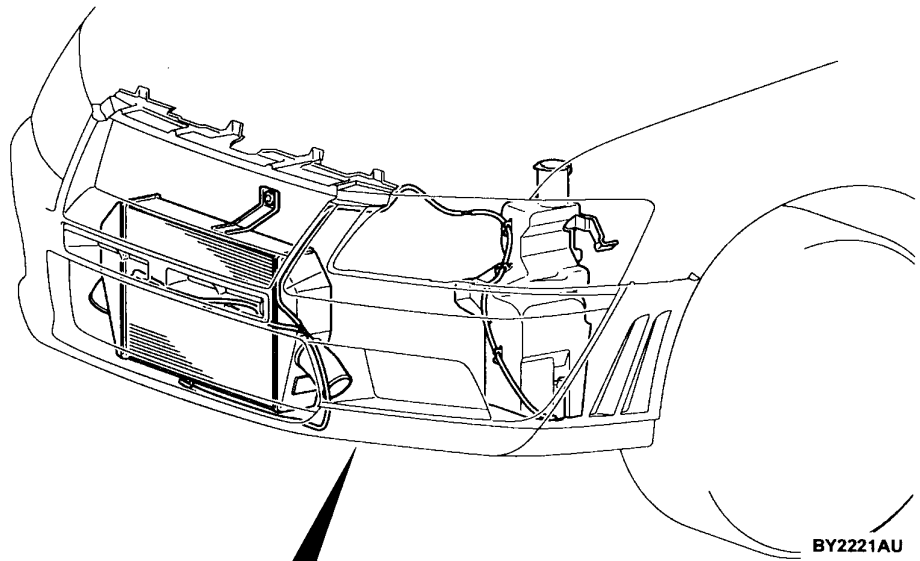

BY2221AU

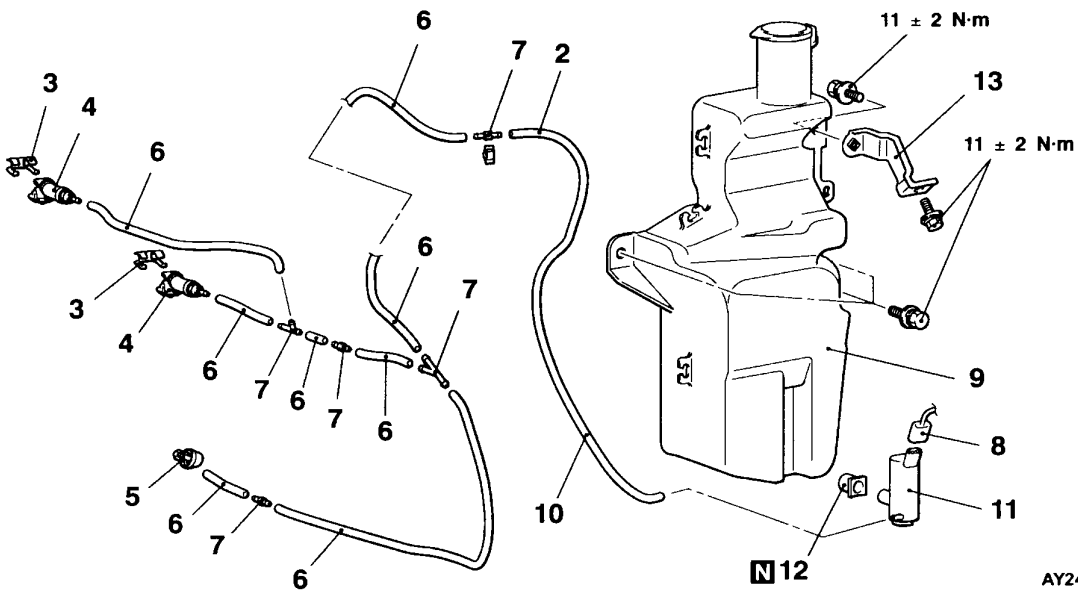

AY2443AU

**Water spray nozzle/Water spray hose removal steps**

- ▶▲ 2. Water spray hose connection
- Tape
- ▶▲ 3. Clamp
- ▶▲ 4. Water spray nozzle (Upper)
- ▶▲ 5. Water spray nozzle (Lower)
- ▶▲ 6. Water spray hose
- ▶▲ 7. Hose Joint

**Washer tank removal steps**

- 2. Water spray hose connection
- 8. Water spray motor harness connector connection
- 9. Washer tank
- 10. Water spray hose
- 11. Water spray motor
- 12. Packing
- 13. Washer tank bracket

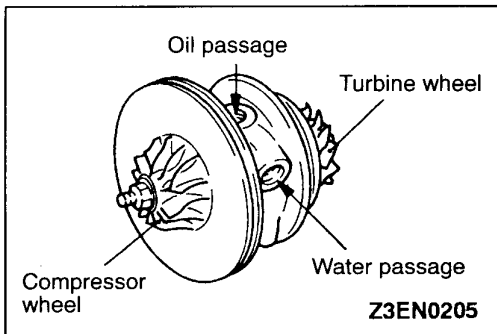

### COMPRESSOR COVER

Check the compressor cover for traces of contact with the compressor wheel and other damage.

### TURBINE WHEEL ASSEMBLY

1. Check the turbine and compressor wheel blades for bend, burr, damage, corrosion and traces of contact on the back side and replace if defective.
2. Check the oil passage of the turbine wheel assembly for deposit and clogging.
3. In the case of water cooled type, check also the water passage for deposit and clogging.
4. Check the turbine wheel and compressor wheel for light and smooth turning.

DISASSEMBLY AND REASSEMBLY

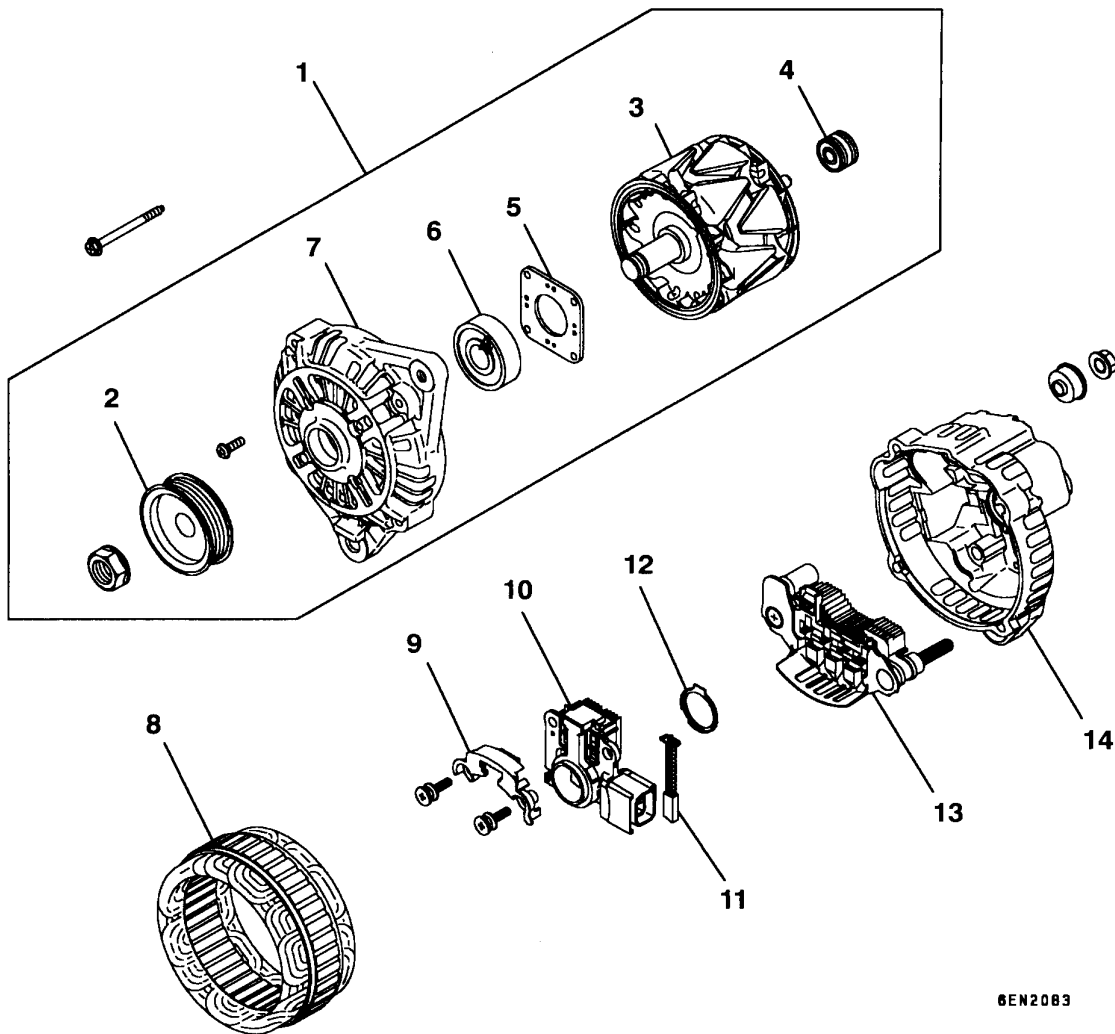

6EN2083

Disassembly steps



1. Front bracket assembly
2. Alternator pulley
3. Rotor
4. Rear bearing
5. Bearing retainer
6. Front bearing
7. Front bracket



8. Stator
9. Plate
10. Regulator assembly
11. Brush
12. Packing
13. Rectifier
14. Rear bracket

**IGNITION COIL SPECIFICATIONS**

Items	Specifications
Type	Molded 2-coil

**SPARK PLUG SPECIFICATIONS**

Items	Specifications
NGK	IGR7A-G
DENSO	VW22PR-DA7

**SERVICE SPECIFICATIONS****IGNITION COIL**

Items	Standard value
Secondary coil resistance k $\Omega$	8.5 – 11.5

**SPARK PLUG**

Items	Standard value	Limit
Spark plug gap mm	0.6 – 0.7	0.75

**RESISTIVE CORD**

Items	Limit
Resistance k $\Omega$	max. 22

**SPECIAL TOOL**

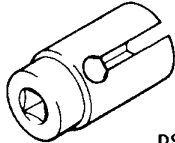
Tool	Number	Name	Use
 D998773	MD998773	Detonation sensor wrench	Detonation sensor removal and installation

# EMISSION CONTROL SYSTEM

## GENERAL INFORMATION

The emission control system consists of the following subsystems:

- Crankcase emission control system
- Evaporative emission control system
- Exhaust emission control system

Items	Name	Specification
Crankcase emission control system	Positive crankcase ventilation (PCV) valve	Variable flow type (Purpose: HC reduction)
Evaporative emission control system	Canister Purge control solenoid valve Check valve	Equipped Duty cycle type solenoid valve Equipped (Purpose: HC reduction)
Exhaust emission control system	Air-fuel ratio control device – MPI system	Oxygen sensor feedback type (Purpose: CO, HC, NOx reduction)
	Exhaust gas recirculation system <ul style="list-style-type: none"> <li>● EGR valve</li> <li>● EGR control solenoid valve</li> </ul>	Equipped Single type Duty cycle type solenoid valve (Purpose: NOx reduction)
	Catalytic converter	Monolith type (Purpose: CO, HC, NOx reduction)

## EMISSION CONTROL DEVICE REFERENCE TABLE

Related parts	Crankcase emission control system	Evaporative emission control system	Air/fuel ratio control system	Catalytic converter	Exhaust gas recirculation system	Reference page
PCV valve	x					17-9
Purge control solenoid valve		x				17-12
Check valve		x				17-12
MPI system component		x	x			GROUP 13A
Catalytic converter				x		17-19
EGR valve					x	17-15
EGR control solenoid valve					x	17-16

## CANISTER

### REMOVAL AND INSTALLATION

**Pre-removal and Post-installation Operation**

- Air Pipe C, Air Hose D Removal and Installation (Refer to GROUP 15 – Inter Cooler.)
- Battery and Battery Tray Removal and Installation
- Air Cleaner Assembly Removal and Installation (Refer to GROUP 15 – Air Cleaner.)

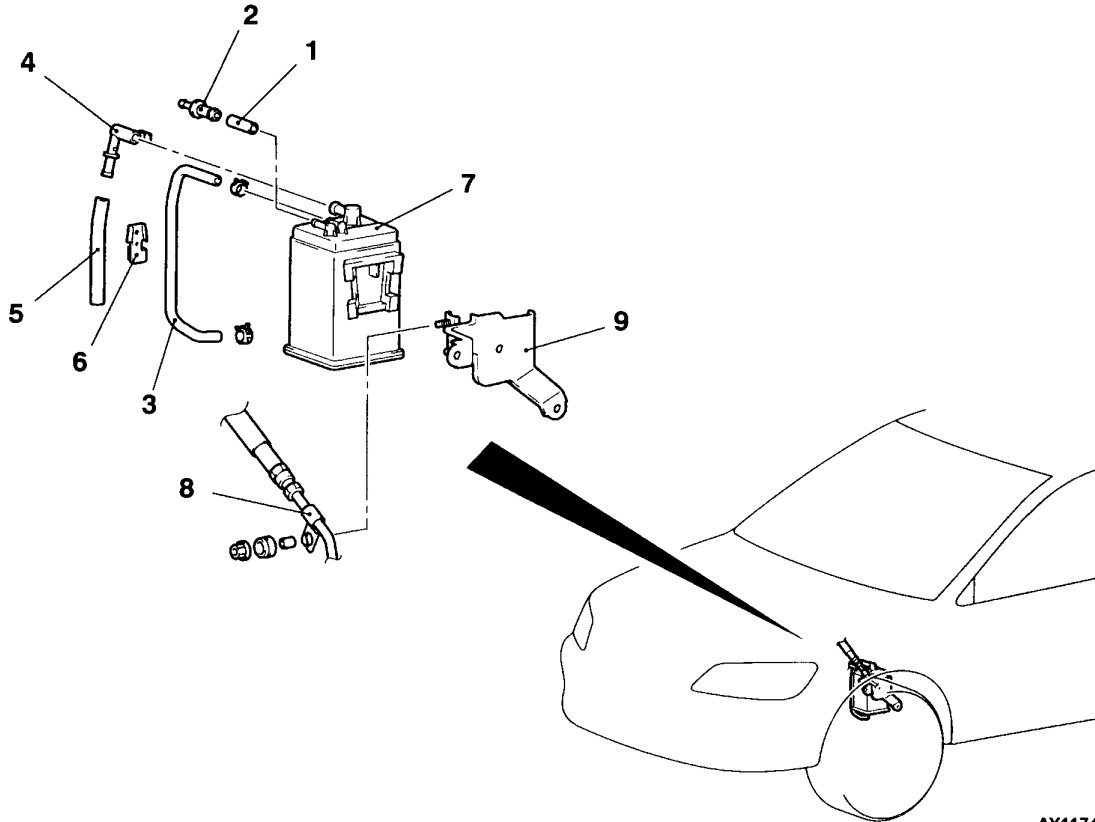

AY1174AU

**Canister removal steps**

- |                   |                              |
|-------------------|------------------------------|
| 1. Purge hose     | 6. Hose clamp                |
| 2. Check valve    | 7. Canister                  |
| 3. Vapor hose     | 8. Fuel high pressure hose   |
| 4. Vent connector | 9. Canister bracket assembly |
| 5. Vapor hose     |                              |

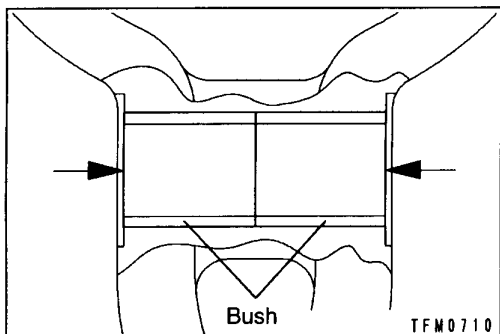

**REASSEMBLY SERVICE POINTS**

**▶A◀ BUSH INSTALLATION**

Press the bush into the position of the release valve shown in the illustration.

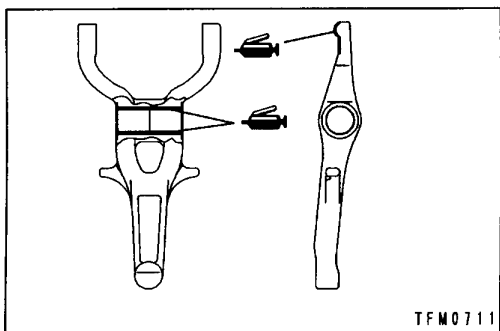

**▶B◀ RELEASE FORK INSTALLATION**

Apply grease on the release fork at the position shown in the illustration.

**Grease**

**Specified grease:**

**mitsubishi genuine grease Part No.0101011 or equivalent**

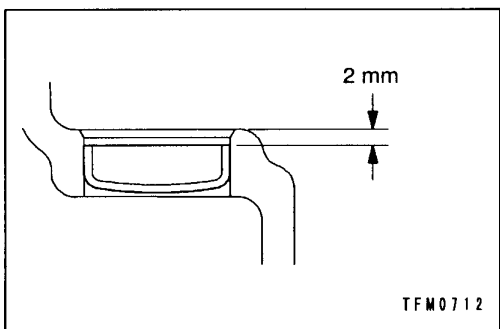

**▶C◀ SEALING CAP INSTALLATION**

Press the sealing cap into the position shown in the illustration while taking care so that it is not tilted.

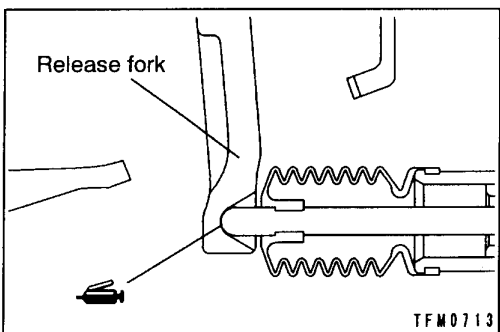

**▶D◀ CLUTCH RELEASE CYLINDER INSTALLATION**

Fill grease in the release fork to the position shown in the illustration.

**Grease**

**Specified grease:**

**mitsubishi genuine grease Part No.0101011 or equivalent**

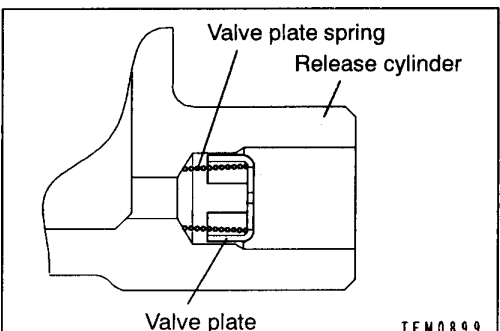

**▶E◀ VALVE PLATE SPRING/VALVE PLATE INSTALLATION**

Set the spring's large diameter side to the valve plate side, and install the valve plate spring and valve plate.

Code No.25 Wrong-diameter tire	Probable cause
<p>Code No.25 is output as wrong-diameter tire when one of the four vehicle speeds is outside the range of specified values in respect to the average of the four vehicle speed sensors, when the vehicle speed is above 20 km/h with the steering wheel in the straight ahead position. However the warning lamp does not light up.</p>	<ul style="list-style-type: none"> <li>● Tire fault</li> <li>● Wheel speed sensor fault</li> <li>● Rotor fault</li> <li>● Wheel bearing fault</li> <li>● Harness or connector fault</li> <li>● ABS-ECU fault &lt;Vehicles with ACD and AYC&gt;</li> <li>● 4WD-ECU fault</li> </ul>

<Vehicles with ACD and AYC>

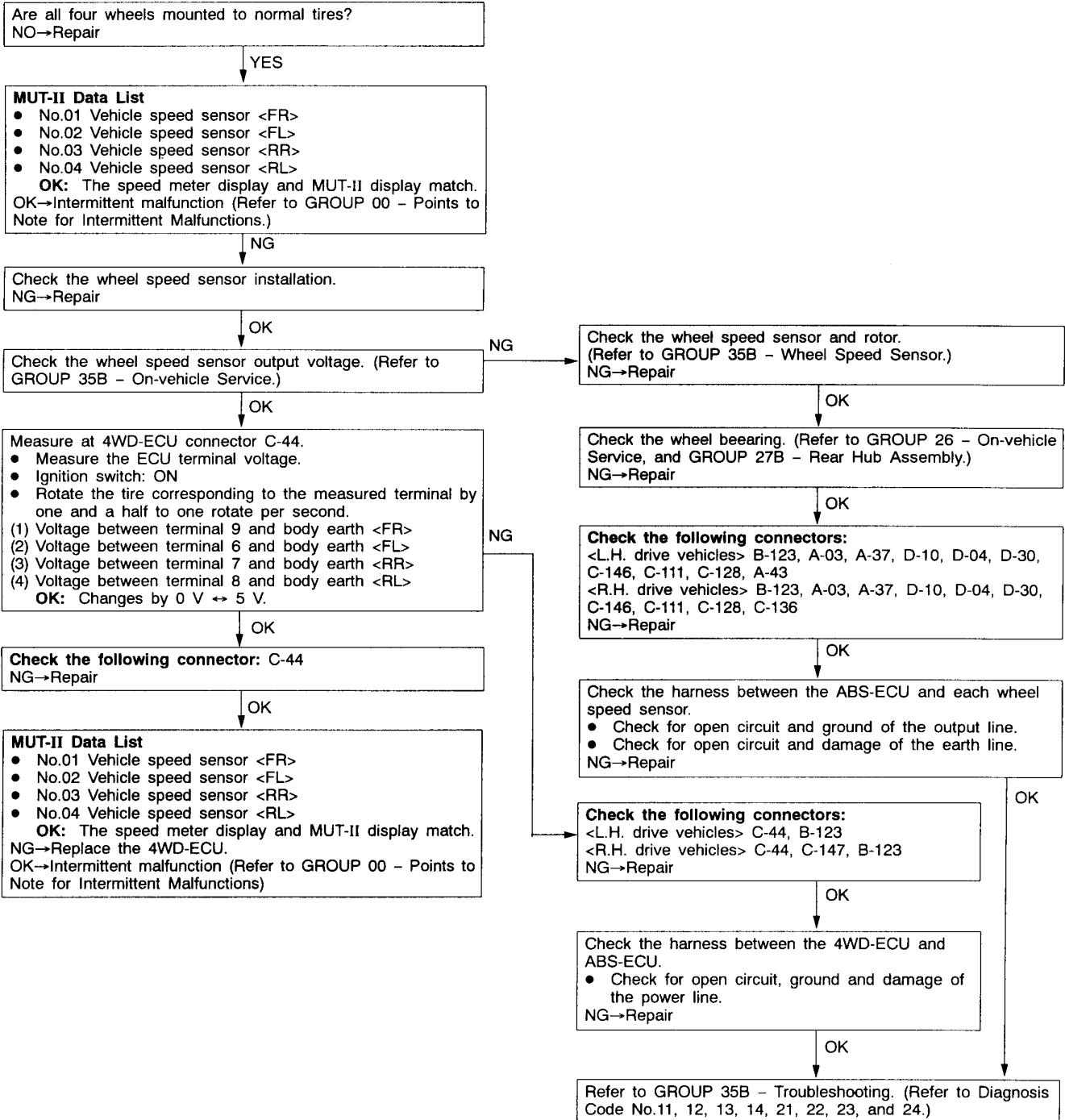

Code No.61 Stop lamp switch system	Probable cause
Code No.61 is output when the stop lamp switch is ON for more than 15 minutes when the vehicle speed is above 15 km/h.	<ul style="list-style-type: none"> <li>● Brake pedal fault</li> <li>● Stop lamp switch fault</li> <li>● Harness or connector fault</li> <li>● 4WD-ECU fault</li> </ul>

Check for brake pedal height  
(Refer to GROUP 35A – On-vehicle Service.)  
NG→Adjust

OK

**MUT-II Data List**

- No.56 Stop lamp switch
- (1) Depress the brake pedal.  
OK: ON
- (2) Release the brake pedal.  
OK: OFF

OK→Intermittent malfunction (Refer to GROUP 00 – Points to Note for Intermittent Malfunctions)

NG

Check the following connector: C-103  
NG→Repair

OK

Check the stop lamp switch.  
(Refer to GROUP 35A – Brake Pedal.)  
NG→Replace

OK

Measure at stop lamp switch connector C-103.

- Disconnect the connector and measure at the harness side.
- Voltage between terminal 2 and earth  
OK: System voltage

OK

NG

Check the following connectors: C-103, C-135  
NG→Repair

OK

Check the harness between the stop lamp switch and battery.

- Check for open circuit or damage of the power line.  
NG→Repair

OK

Measure at 4WD-ECU connector C-43.

- Measure the ECU terminal voltage.
- Voltage between terminal 38 and earth
- (1) Depress the brake pedal.  
OK: System voltage
- (2) Release the brake pedal  
OK: 1 V or less

NG

OK

Check the following connector: C-43  
NG→Repair

OK

**MUT-II Data List**

- No.56 Stop lamp switch
- (1) Depress the brake pedal.  
OK: ON
- (2) Release the brake pedal.  
OK: OFF

NG→Replace the 4WD-ECU.  
OK→Intermittent malfunction (Refer to GROUP 00 – Points to Note for Intermittent Malfunctions)

Check the following connectors:  
<L.H. drive vehicles> C-103, C-43, C-108, C-130  
<R.H. drive vehicles> C-103, C-43  
NG→Repair

OK

Check the harness between the 4WD-ECU and stop lamp switch.

- Check for open circuit and damage of the power line.  
NG→Repair

OK

Check the stop lamp bulb.  
NG→Replace

OK

Check the harness between the stop lamp switch and stop lamp.

- Check for open circuit and damage of the power line.
- Check the harness between the stop lamp and body earth.
- Check for open circuit and damage of the earth line.  
NG→Repair

Terminal no.	Check item	Check condition		Normal state
24*2	Longitudinal G sensor earth, lateral G sensor earth	Any time		1 V or less
26	ECU earth	Any time		1 V or less
31	ECU backup power supply	Any time		System voltage
32	Pressure sensor	Ignition switch: ON		0.5 – 1.5 V
33	Steering wheel sensor <ST-1>	Ignition switch: ON	Steering wheel: Turn slowly	1 – 2 V ↔ 2.5 – 4.5 V flushing
34	Steering wheel sensor <ST-2>	Ignition switch: ON	Steering wheel: Turn slowly	1 – 2 V ↔ 2.5 – 4.5 V flushing
35	Diagnosis data input/output	–		–
36	Idle switch	Ignition switch: ON	Accelerator pedal: Full closed	1 V or less
			Accelerator pedal: Depress	4.5 – 5.0 V
37	Parking brake switch	Ignition switch: ON	Parking brake lever: Pull	1 V or less
			Parking brake lever: Release	System voltage
38	Stop lamp switch	Ignition switch: ON	Brake pedal: Depress	System voltage
			Brake pedal: Release	1 V or less
39	TPS	Ignition switch: ON	Accelerator pedal: Full closed	0.5 – 0.7 V
			Accelerator pedal: Full throttle	4.5 – 5.5 V
40	ACD mode indicator lamp <TARMAC>	Ignition switch: ON	ACD mode indicator lamp position: TARMAC	0 V
			ACD mode indicator lamp position: Except for above	Approx. 10.5 V
42	ECU earth	Any time		1 V or less
43	Pressure sensor earth	Any time		1 V or less
44	Steering wheel sensor <ST-N>	Ignition switch: ON	Steering wheel: Neutral	1 – 2 V
			Steering wheel: Turn from the neutral position	2.5 – 4.5 V
46	Diagnosis control	–		–
47	ACD mode switch	Ignition switch: ON	Switch: Press	System voltage
			Switch: Release	0 V
49*1	ABS monitor	With ABS not active		System voltage
		With ABS active		1.5 V or less
50*2	Earth	Any time		1 V or less
51	ACD mode indicator lamp <SNOW>	Ignition switch: ON	ACD mode indicator lamp position: SNOW	0 V
			ACD mode indicator lamp position: Except for above	Approx. 10.5 V
52	ACD mode indicator lamp <GRAVEL>	Ignition switch: ON	ACD mode indicator lamp position: GRAVEL	0 V
			ACD mode indicator lamp position: Except for above	Approx. 10.5 V

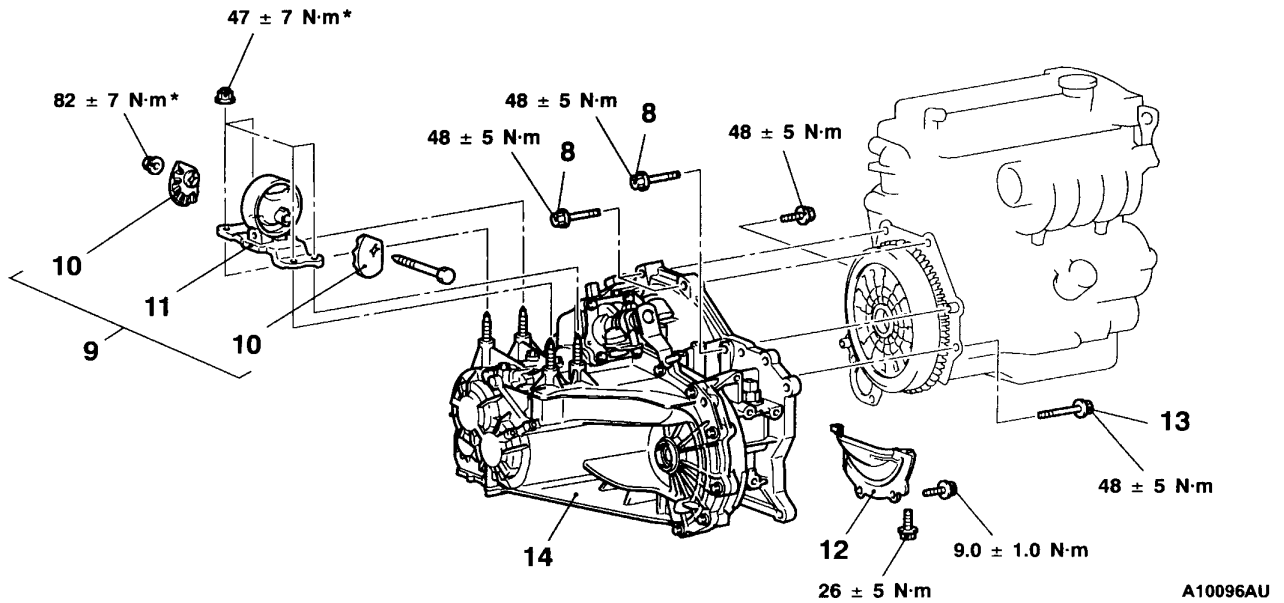

- 8. Transmission assembly upper part coupling bolts
- 9. Transmission mount assembly
- 10. Transmission mount stopper
- 11. Transmission mount bracket
  - Engine assembly supporting
  - Clutch release bearing connection
- 12. Bell housing cover

- 13. Transmission assembly lower part coupling bolts
- 14. Transmission assembly

**Caution**  
 \*: Indicates parts which should be initially tightened, and then fully tightened after placing the vehicle horizontally and loading the full weight of the engine on the vehicle body.

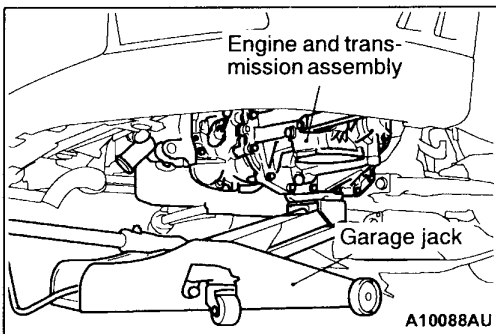

**REMOVAL SERVICE POINTS**

**ENGINE AND TRANSMISSION ASSEMBLY SUPPORTING/TRANSMISSION MOUNT ASSEMBLY REMOVAL**

While supporting the engine and transmission assembly with a garage jack, remove the transmission mount assembly.

**SNAP RINGS (FOR ADJUSTMENT OF OUTPUT SHAFT BEARING CLEARANCE)**

Thickness mm	Identification	Part No.	Thickness mm	Identification	Part No.
1.36	Yellow	MD748449	1.55	White	MD748452
1.40	Green	MD748450	1.58	Brown	MD746604
1.44	None	MD746602	1.63	Orange	MD748453
1.48	Black	MD748451	1.68	Blue	MD748454
1.51	Blue	MD746603			

**SNAP RINGS (FOR ADJUSTMENT OF OUTPUT SHAFT 3RD SPEED GEAR CLEARANCE)**

Thickness mm	Identification	Part No.	Thickness mm	Identification	Part No.
2.81	None	MD746594	2.97	Green	MD746598
2.85	Blue	MD746595	3.01	Black	MD746599
2.89	Brown	MD746596	3.05	White	MD746600
2.93	Yellow	MD746597	3.09	Orange	MD746601

**SPACERS (FOR ADJUSTMENT OF CENTER DIFFERENTIAL CASE PRELOAD)**

Thickness mm	Identification	Part No.	Thickness mm	Identification	Part No.
0.74	74	MD727660	1.04	04	MD720944
0.77	77	MD754476	1.07	07	MD750945
0.80	80	MD727661	1.10	J	MD710454
0.83	83	MD720937	1.13	D	MD700270
0.86	86	MD720938	1.16	K	MD710455
0.89	89	MD720939	1.19	L	MD710456
0.92	92	MD720940	1.22	G	MD700271
0.95	95	MD720941	1.25	M	MD710457
0.98	98	MD720942	1.28	N	MD710458
1.01	01	MD720943	1.31	E	MD706547

**SPACERS (FOR ADJUSTMENT OF CENTER DIFFERENTIAL CASE PINION BACKLASH)**

Thickness mm	Identification	Part No.	Thickness mm	Identification	Part No.
0.6	–	MD748362	0.9	–	MD748365
0.7	–	MD748363	1.0	–	MD748366
0.8	–	MD748364	1.1	–	MD748367

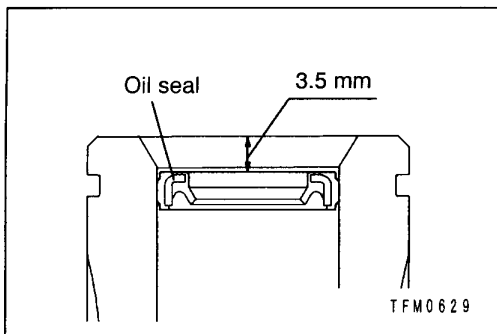

**REASSEMBLY SERVICE POINTS**

**▶A◀ OIL SEAL INSTALLATION**

Accurately tap in the oil seal to the dimensions shown in the illustration.

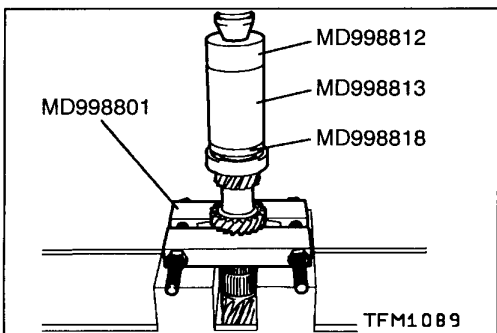

**▶B◀ BALL BEARING INSTALLATION**

Using the special tool, install the ball bearing onto the input shaft.

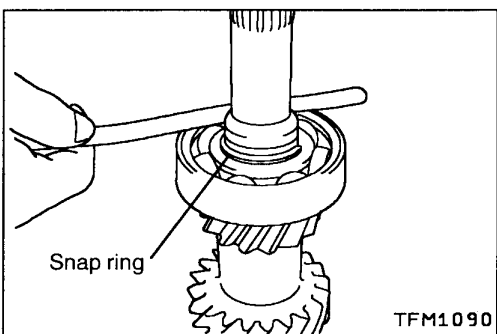

**▶C◀ SNAP RING INSTALLATION**

Select and install the snap ring so that the input shaft front bearing clearance is at the standard value.

**Standard value: 0.01 mm tight to 0.12 mm loose**

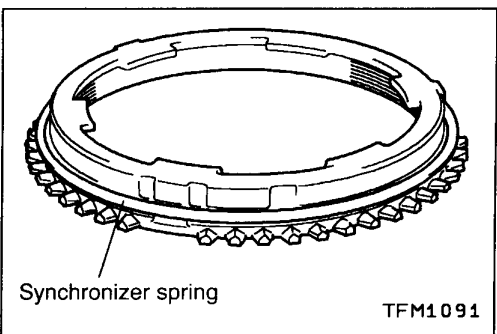

**▶D◀ SYNCHRONIZER SPRING INSTALLATION**

Accurately install the synchronizer spring onto the position of the synchronizer ring shown in the illustration.

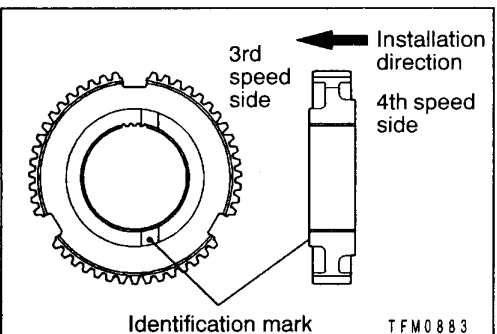

**▶E◀ 3RD-4TH SPEED SYNCHRONIZER HUB INSTALLATION**

Install the 3rd-4th speed synchronizer hub onto the input shaft at the direction shown in the illustration.

# SPEEDOMETER GEAR DISASSEMBLY AND REASSEMBLY

 Apply gear oil on all sliding sections before installing.

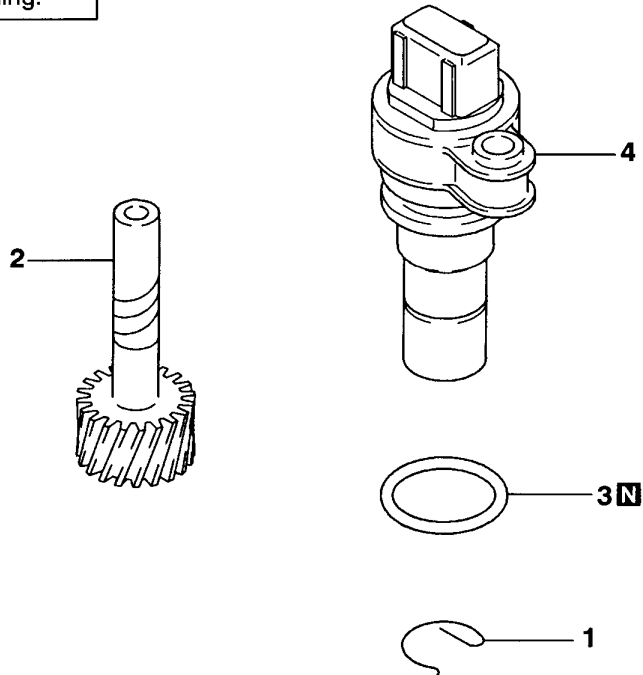

TFM0593

### Disassembly steps

1. e-clip
2. Speedometer driven gear
3. O-ring
4. Sleeve

**REASSEMBLY SERVICE POINTS****▶A◀ O-RING INSTALLATION**

Apply hypoid gear oil on the O-ring.

**Hypoid gear oil**

**Specified oil:**

**MITSUBISHI genuine “DIA-QUEEN SUPER” hypoid gear oil (GL-5) or equivalent**

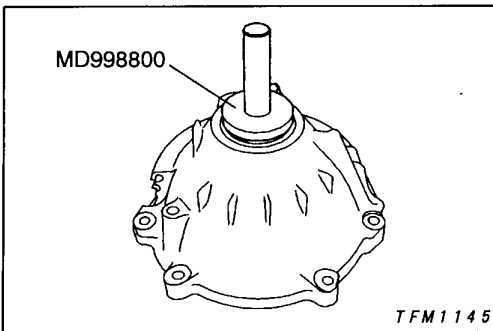
**▶B◀ OIL SEAL INSTALLATION**

Apply hypoid gear oil on the lip section of the oil seal, and install using the special tool.

**Hypoid gear oil**

**Specified oil:**

**MITSUBISHI genuine “DIA-QUEEN SUPER” hypoid gear oil (GL-5) or equivalent**

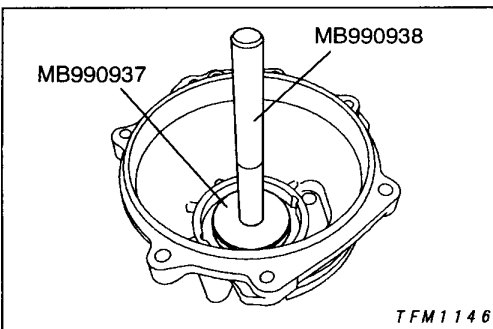
**▶C◀ OIL SEAL INSTALLATION**

Apply hypoid gear oil on the lip section of the oil seal, and install using the special tool.

**Hypoid gear oil**

**Specified oil:**

**MITSUBISHI genuine “DIA-QUEEN SUPER” hypoid gear oil (GL-5) or equivalent**

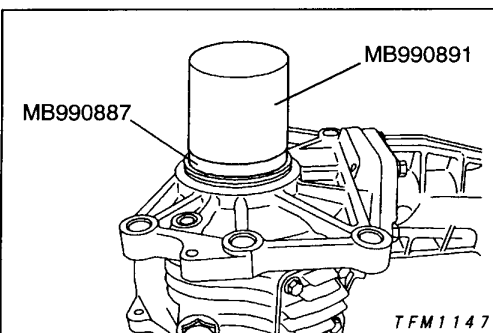
**▶D◀ OIL SEAL INSTALLATION**

Apply hypoid gear oil on the lip section of the oil seal, and install using the special tool.

**Hypoid gear oil**

**Specified oil:**

**MITSUBISHI genuine “DIA-QUEEN SUPER” hypoid gear oil (GL-5) or equivalent**

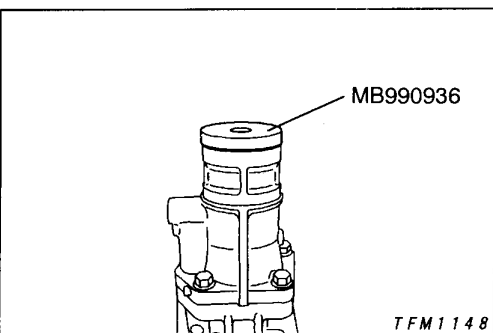
**▶E◀ OIL SEAL INSTALLATION**

Apply hypoid gear oil on the lip section of the oil seal, and install using the special tool.

**Hypoid gear oil**

**Specified oil:**

**MITSUBISHI genuine “DIA-QUEEN SUPER” hypoid gear oil (GL-5) or equivalent**

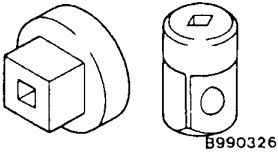
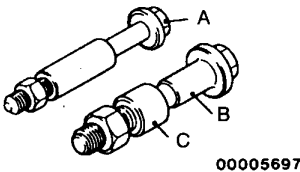
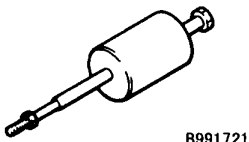
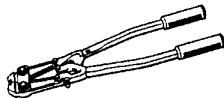
Tool	Number	Name	Use
	MB990685	Torque wrench	Measurement of wheel bearing rotation starting torque
	MB990326	Preload socket	Measurement of wheel bearing rotation starting torque
	A: MB991017 B: MB990998 C: MB991000	A,B: Front hub remover and installer C: Spacer	<ul style="list-style-type: none"> <li>Provisional holding of the wheel bearing</li> <li>Measurement of wheel bearing rotation starting torque</li> <li>Measurement of wheel bearing axial play MB991000, which belongs to MB990998, should be used as a spacer.</li> </ul>
	MB991721	Sliding hammer	Output shaft removal
	MB991561	Boot band clipping tool	Resin boot band installation

MB990925

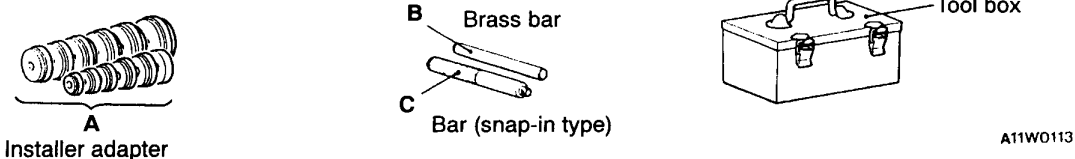

A  
Installer adapter

B Brass bar

C Bar (snap-in type)

Tool box

A11W0113

Type	Tool number	O.D. mm	Type	Tool number	O.D. mm
A	MB990926	39	A	MB990933	63.5
	MB990927	45		MB990934	67.5
	MB990928	49.5		MB990935	71.5
	MB990929	51		MB990936	75.5
	MB990930	54		MB990937	79
	MB990931	57	B	MB990938	-
	MB990932	61	C	MB990939	-

---

# REAR AXLE

## CONTENTS

<b>GENERAL INFORMATION</b> .....	2	Wheel Bearing Axial Play Check .....	22
<b>SERVICE SPECIFICATIONS</b> .....	3	Wheel Bearing Rotary-sliding Resistance Check .	22
<b>LUBRICANTS</b> .....	3	Hub Bolt Replacement .....	23
<b>SEALANTS</b> .....	4	Differential Carrier Oil Seal Replacement .....	23
<b>SPECIAL TOOLS</b> .....	4	Action When Battery Runs Out .....	24
<b>TROUBLESHOOTING (AYC)</b> .....	8	<b>REAR HUB ASSEMBLY</b> .....	25
<b>ON-VEHICLE SERVICE</b> .....	16	<b>KNUCKLE</b> .....	28
Rear Axle Total Backlash Check .....	16	<b>DRIVE SHAFT</b> .....	29
Gear Oil Level Check .....	16	<b>DIFFERENTIAL CARRIER</b>	
Gear Oil Change .....	17	<b>&lt;VEHICLES WITH MECHANICAL LSD&gt;</b> .....	35
Fluid Level Check .....	19	<b>DIFFERENTIAL CARRIER</b>	
Bleeding .....	19	<b>&lt;VEHICLES WITH AYC&gt;</b> .....	55
AYC Operation Check .....	20	<b>HYDRAULIC UNIT</b>	
Oil Pressure Check .....	21	<b>&lt;VEHICLES WITH ACD+AYC&gt;</b> .....	61

---

**INSPECTION PROCEDURE 6**

Rear tires are noisy during low-speed cornering. Vehicle skews.	Probable cause
The hydraulic unit or torque transfer differential is probably defective.	<ul style="list-style-type: none"> <li>Defective hydraulic unit</li> <li>Defective torque transfer differential</li> </ul>

**NOTE**

This symptom is limited only when the diagnosis code is correct.

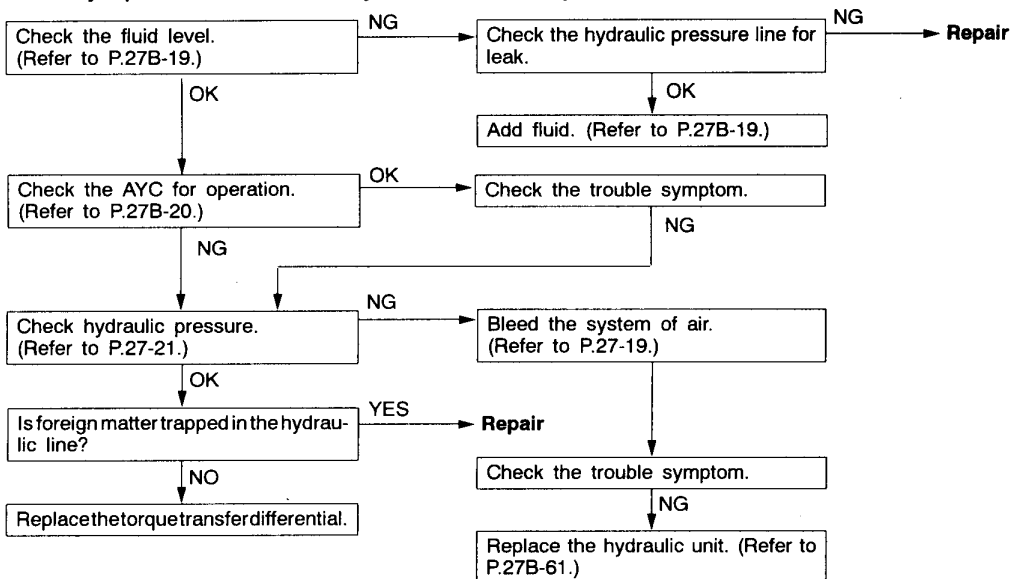

**INSPECTION PROCEDURE 7**

Noise is produced from the torque transfer differential during turning	Probable cause
The torque transfer differential is probably defective.	<ul style="list-style-type: none"> <li>Defective torque transfer differential</li> </ul>

**NOTE**

This symptom is limited only when the diagnosis code is correct.

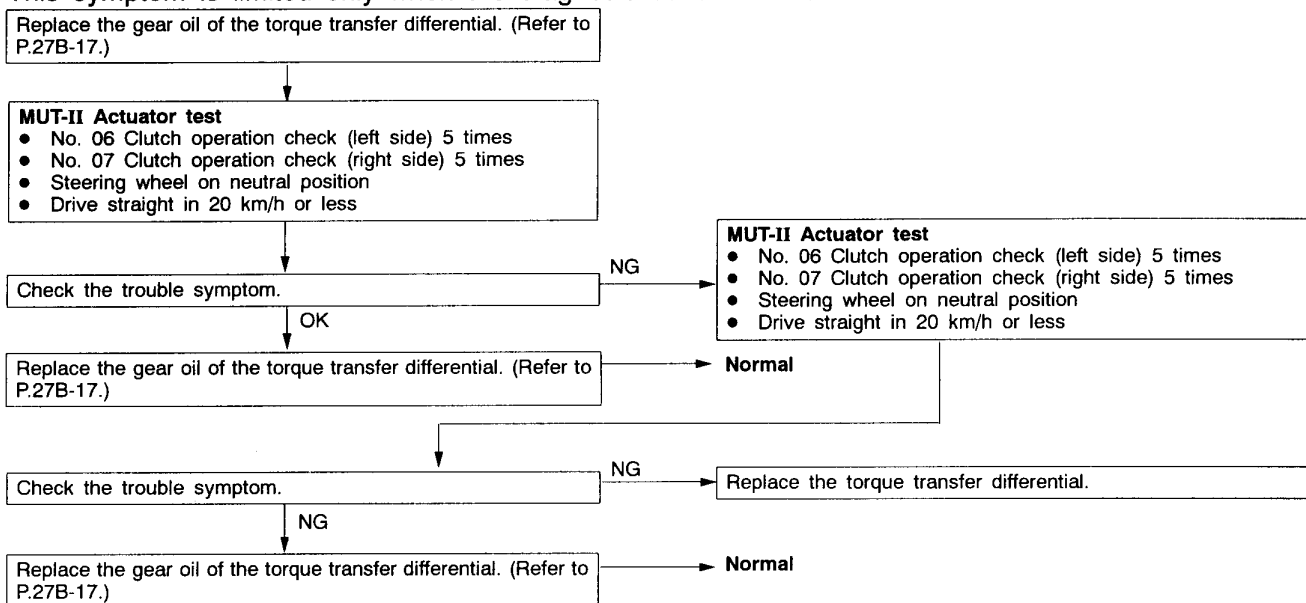

# DRIVE SHAFT

## REMOVAL AND INSTALLATION

### Caution

1. If the vehicle is equipped with the Brembo disc brake, during maintenance, take care not to contact the parts or tools to the caliper because the paint of caliper will be scratched. And if there is brake fluid on the caliper, wipe out quickly.
2. With the part marked with \*, first temporarily tighten it, then ground the vehicle and tighten it to specification in unloaded condition.

**Pre-removal Operation**

- Gear Oil Draining (Refer to P.27-17.)
- Center Exhaust Pipe Removal (Refer to GROUP 15.)

**Post-installation Operation**

- Press dust cover with a finger to check for crack or damage in the dust cover.
- Center Exhaust Pipe Installation (Refer to GROUP 15.)
- Gear Oil Filling (Refer to P.27-17.)
- Parking Brake Lever Stroke Check and Adjustment
- Wheel Alignment Check and Adjustment (Refer to GROUP 34 – On-vehicle Service.)

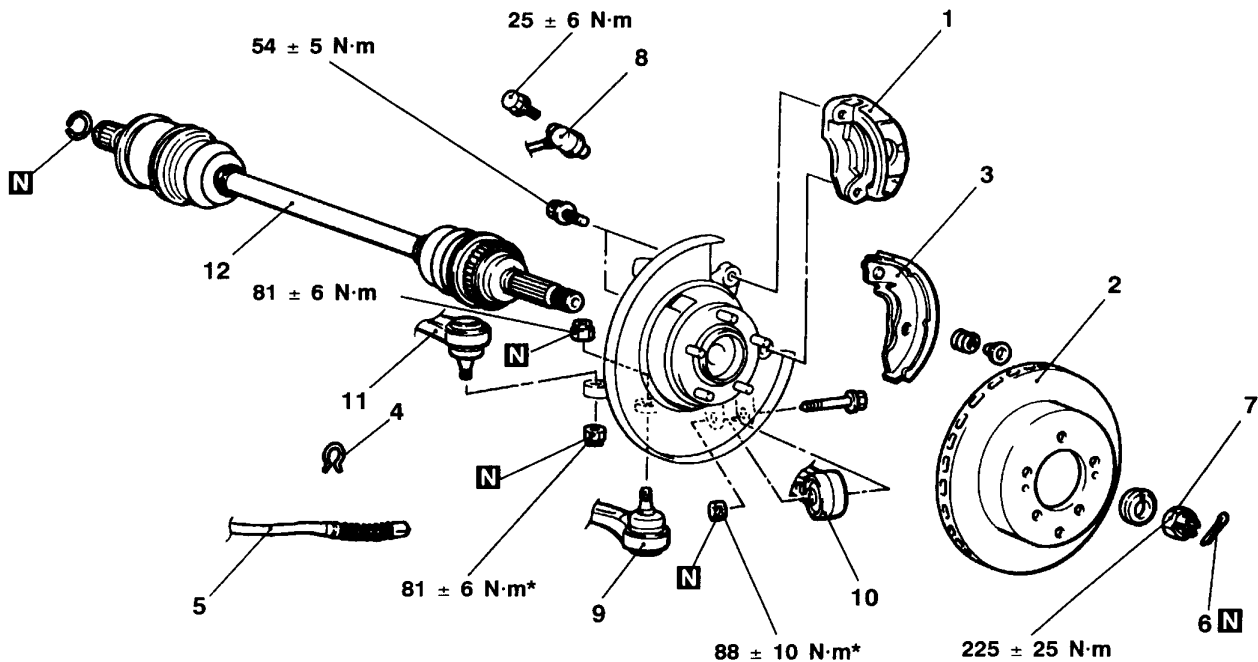

A11M0069

### Removal steps



1. Rear brake caliper
2. Rear brake disc
3. Parking brake shoe & lining assembly (Refer to GROUP 36 – Parking Brake Drum.)
4. Clip
5. Parking brake cable connection
6. Split pin



7. Drive shaft nut
8. Vehicle speed sensor<Vehicles with ABS or ACD>
9. Knuckle and trailing arm connection
10. Knuckle and lower arm connection
11. Knuckle and toe-control arm connection



12. Rear drive shaft assembly

REASSEMBLY

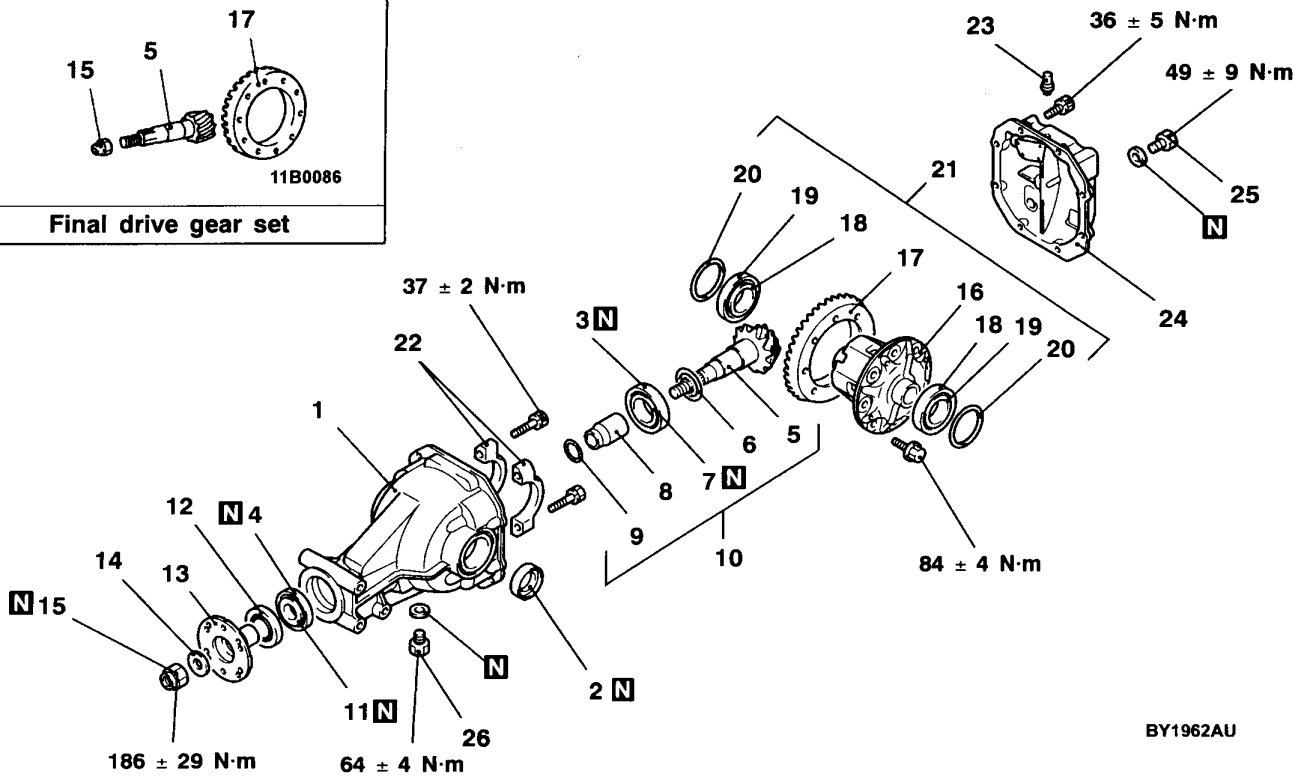
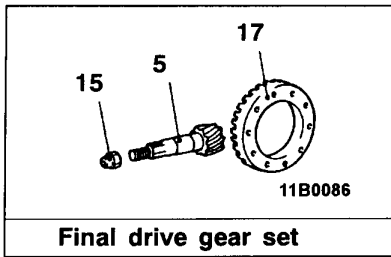

BY1962AU

Reassembly steps

- |   |  |
|---|--|
| <ul style="list-style-type: none"> <li>▶A◀ 1. Differential carrier</li> <li>▶B◀ 2. Oil seal</li> <li>▶C◀ 3. Drive pinion rear bearing outer race</li> <li>▶D◀ 4. Drive pinion front bearing outer race</li> <li>• Drive pinion height adjustment</li> <li>5. Drive pinion</li> <li>6. Drive pinion rear shim (For adjusting drive pinion height)</li> <li>7. Drive pinion rear bearing inner race</li> <li>8. Drive pinion spacer</li> <li>▶E◀ • Drive pinion turning torque adjustment</li> <li>9. Drive pinion front shim (For adjusting drive pinion preload)</li> <li>10. Drive pinion assembly</li> <li>▶E◀ 11. Drive pinion front bearing inner race</li> <li>▶E◀ 12. Oil seal</li> </ul> | <ul style="list-style-type: none"> <li>13. Companion flange</li> <li>14. Washer</li> <li>15. Self-locking nut</li> <li>16. Limited slip differential case assembly</li> <li>▶F◀ 17. Drive gear</li> <li>▶G◀ 18. Side bearing inner race</li> <li>▶G◀ 19. Side bearing outer race</li> <li>20. Side bearing spacer</li> <li>▶H◀ 21. Differential case assembly</li> <li>▶H◀ 22. Bearing cap</li> <li>23. Vent plug</li> <li>24. Differential cover assembly</li> <li>25. Drain plug</li> <li>26. Filler plug</li> <li>▶H◀ • Final drive gear backlash adjustment</li> </ul> |
|---|--|

<Differential support member>

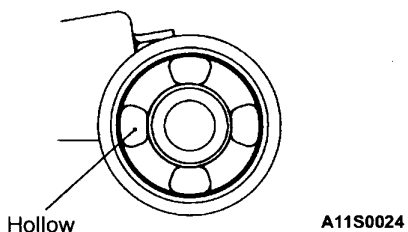
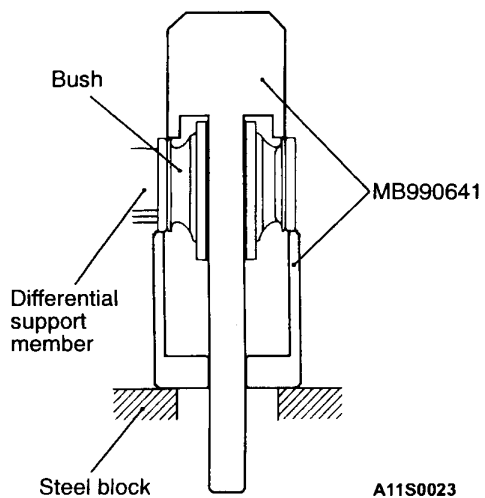

<Differential support arm>

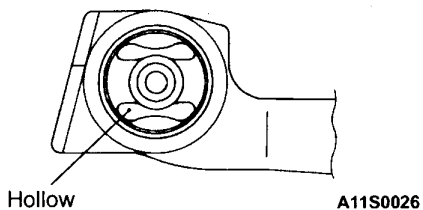
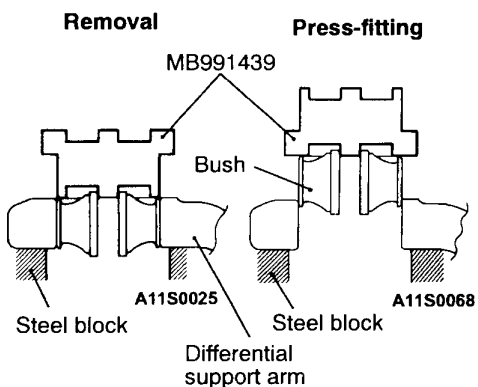

**BUSHING REPLACEMENT**

1. Remove and press fit the bush with special tool.
2. Press fit th bush so that the hollow of the bush is on the position shown as the illustration.
3. Press fill the bush until the surface of the outer sleeve of the bush,differential support member or differential support arm contact.

**GENERAL INFORMATION**

Inertia principal axes system is incorporated into the engine mount system.

Upper installation of roll mount reduces engine rolling, and increase of insulator bore also reduces idle vibration.

**CONSTRUCTION DIAGRAM**

<Engine mount, Transmission mount>

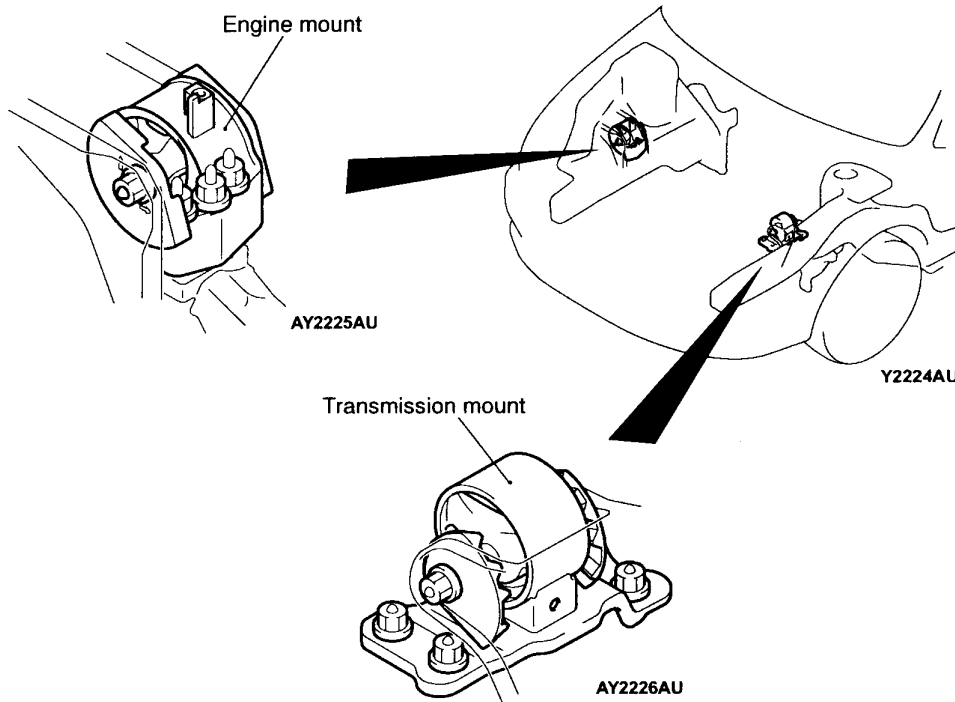

<Engine roll stopper, Centermember, Crossmember: L.H. drive vehicles>

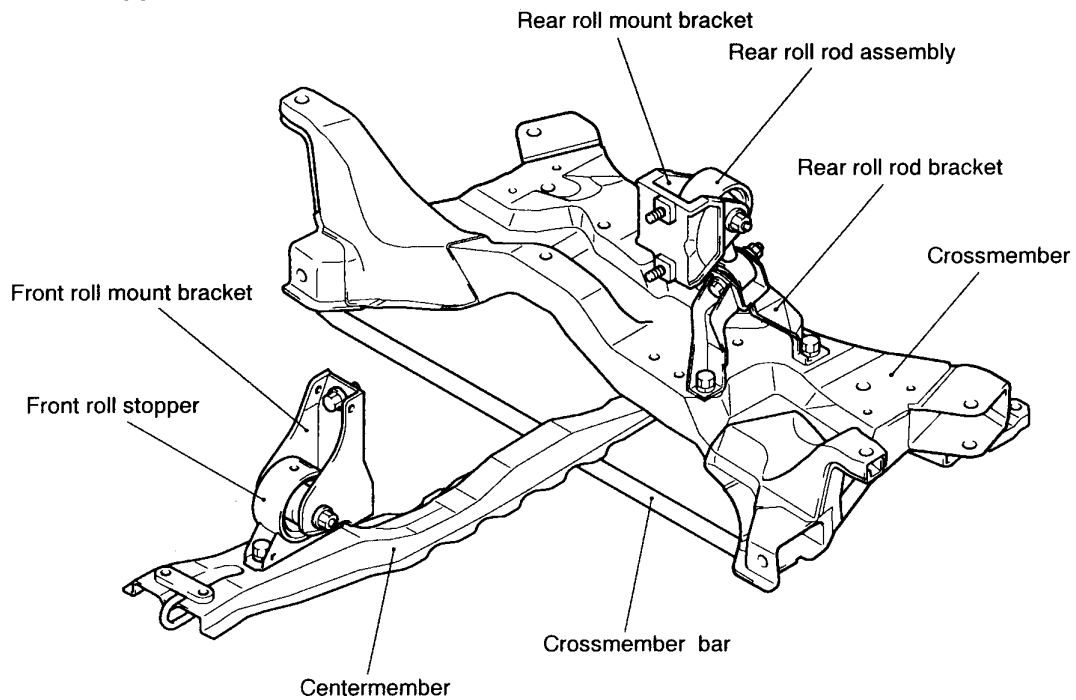

A10012AU

**Tightening torque: 52 ± 2 N·m**

3. Confirm that the toe-in is at the standard value.
4. Use a turning radius gauge to check that the steering angle is at the standard value.

**Standard value:**

Inner wheels	31°45' ± 1°30'
Outer wheels (for reference)	27°15'

**TOE-OUT ANGLE ON TURNS**

To check the steering linkage, especially after the vehicle has been involved in an accident or if an accident is presumed, it is advisable to check the toe-out angle on turns in addition to the wheel alignment.

Conduct this test on the left turn as well as on the right turn.

**Standard value:**

Items	Specifications
Toe-out angle on turns (inner wheel when outer wheel at 20°)	22°00' ± 1°30'

**CAMBER, CASTER AND KINGPIN INCLINATION**

**Standard value:**

Items	Specifications
Camber (Selectable from 2 options)	-1°00' ± 30'* or -2°00' ± 30'*
Caster	3°55' ± 30'*
Kingpin inclination	13°45' ± 1°30'

**NOTE**

1. \*: difference between right and left wheels must be less than 30'
2. Caster and kingpin inclination are preset at the factory and cannot be adjusted.

**SELECTION THE CAMBER**

Select the camber by the installation direction of the allow of the connecting bolt of the strut assembly and the knuckle.

- -1°00' ± 30': Install the bolt turning the allow to the direction of vehicle inside.
- -2°00' ± 30': Install the bolt turning the allow to the direction of vehicle outside.

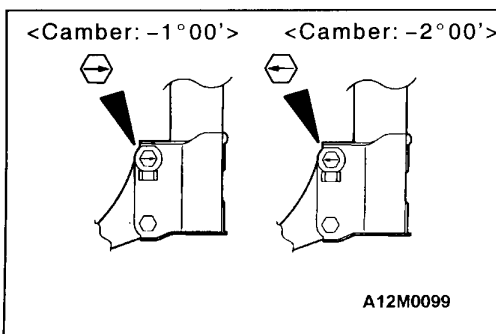

**BALL JOINT DUST COVER CHECK**

1. Check the dust cover for cracks or damage by pushing it with finger.
2. If the dust cover is cracked or damaged, replace the lower arm assembly.

**NOTE**

Cracks or damage of the dust cover may cause damage of the ball joint.

## ON-VEHICLE SERVICE

### WHEEL ALIGNMENT CHECK AND ADJUSTMENT

1. The rear suspension, wheels and tyres should be serviced to normal condition prior to measurement of wheel alignment.
2. Measure the wheel alignment with the vehicle parked on a level surface.

#### TOE-IN

##### Standard value:

**At the centre of tyre tread  $3 \pm 2$  mm**

**Toe angle (per wheel)  $0^{\circ}09' \pm 06'$**

If toe-in is not within the standard value, adjust by following procedures.

- (1) Be sure to adjust the camber before making toe adjustment.

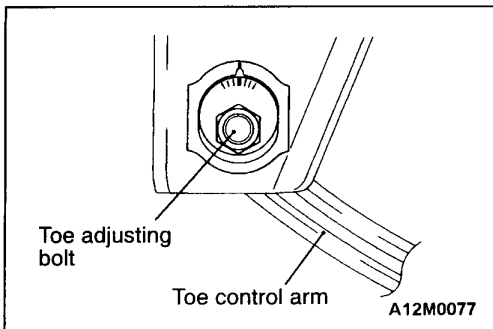

- (2) Carry out adjustment by turning the toe adjusting bolt (toe control arm mounting bolt which is located on the inner side of the body).

**Left wheel: Turning clockwise (+) toe-in**

**Right wheel: Turning clockwise (-) toe-in**

##### NOTE

The scale has gradations of approximately 3.3 mm (single side toe angle equivalent to 19')

#### CAMBER

**Standard value:  $-1^{\circ}00' \pm 30'$**

**(difference between right and left wheel: less than 30')**

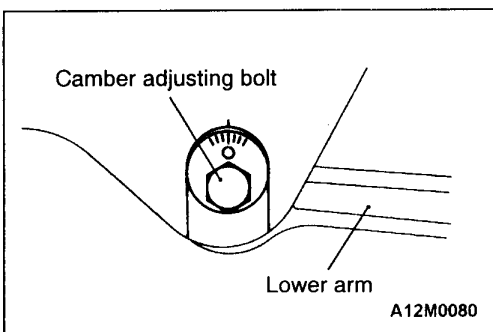

If camber is not within the standard value, adjust by following procedures.

- (1) Carry out adjustment by turning the camber adjusting bolt (lower arm to rear crossmember mounting bolt).

**Left wheel: Turning clockwise (+) camber**

**Right wheel: Turning clockwise (-) camber**

##### NOTE

The scale has gradations of approximately 14'.

- (2) After adjusting the camber, the toe should be adjusted.

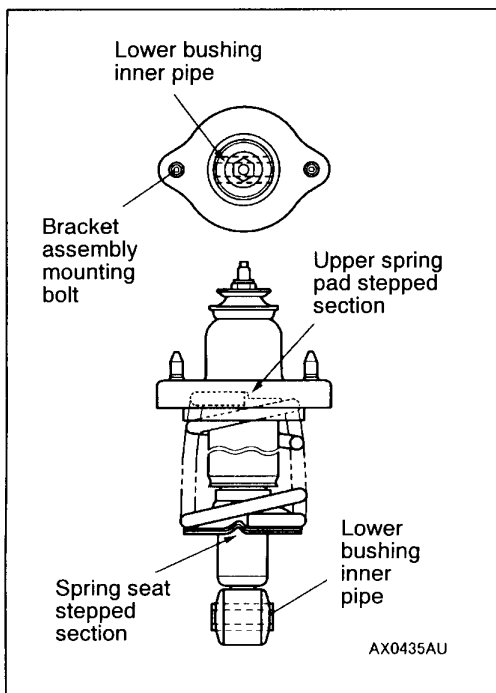

## REASSEMBLY SERVICE POINTS

### ▶A◀ COIL SPRING INSTALLATION

1. Use the special tools (MB991237, MB991239) to compress the coil spring, and install it to the spring seat of the shock absorber.

#### Caution

**Do not use an impact wrench as it will cause the bolt of the special tool to be seized.**

2. Align the end of the coil spring with the stepped section of the spring seat of the shock absorber.

### ▶B◀ UPPER SPRING PAD INSTALLATION

Align the stepped section of the upper spring pad with the end of the coil spring, and install the upper spring pad.

### ▶C◀ BRACKET ASSEMBLY INSTALLATION

Install the bracket assembly so that the lower bushing inner pipe of the shock absorber and the line between the bracket mounting bolts are straight when looking from above.

### ▶D◀ SELF-LOCKING NUT INSTALLATION

1. Provisionally tighten the self-locking nut.
2. After removing the special tools (MB991237, MB991239), tighten the self-locking nut to the specified torque.

**Specified torque: 25 ± 5 N·m**

#### Caution

**To prevent the piston rod lock nut inside the strut from loosening, do not use an impact wrench when the self-locking nut is tightened.**

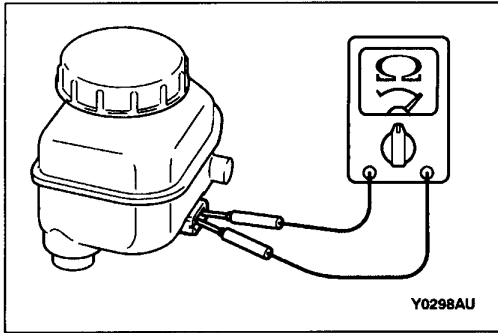

**BRAKE FLUID LEVEL SENSOR CHECK**

The brake fluid level sensor is in good condition if there is no continuity when the float surface is above “MIN” and if there is continuity when the float surface is below “MIN”.

**DISC BRAKE PAD CHECK AND REPLACEMENT  
<Except for Brembo disc brake>**

**NOTE**

The wear indicator contacts the brake disc when the brake pad thickness reaches approximately 2 mm and emit a squealing sound to warn the driver.

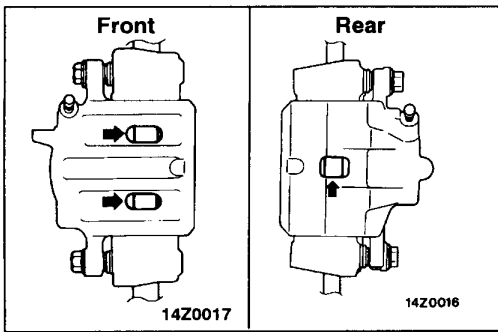

1. Check the brake pad thickness through the caliper body check port.

**Standard value: 10.0 mm**

**Limit: 2.0 mm**

2. When the thickness is less than the limit, always replace the pads at an axle set.

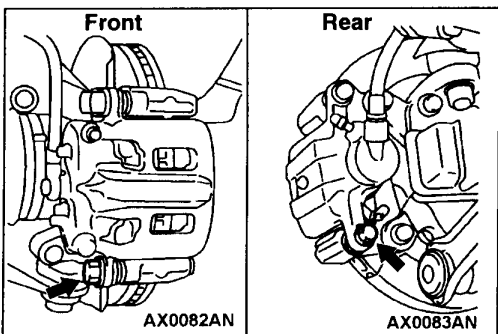

3. Remove the pin bolt. Pivot the caliper assembly and hold it with wires.

**Caution**

**Do not wipe off the special grease that is on the pin or allow it to contaminate the pin.**

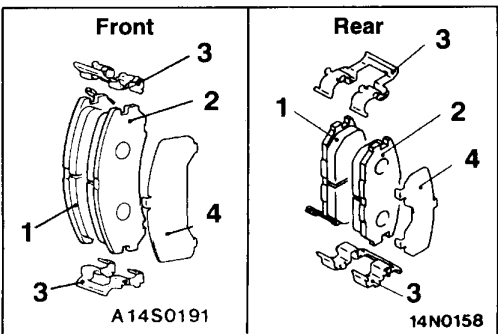

4. Remove the following parts from the caliper support.
  1. Pad and wear indicator assembly
  2. Pad assembly
  3. Clip
  4. Outer shim
5. In order to measure the brake drag force after pad installation, measure the rotary-sliding resistance of the hub with the pads removed. (Refer to P.35A-21.)
6. Install the pads and caliper assembly, and then check the brake drag force. (Refer to P.35A-21.)

CLICK HERE TO **DOWNLOAD** THE COMPLETE MANUAL

- Thank you very much for reading the preview of the manual.
- You can download the complete manual from: [www.heydownloads.com](http://www.heydownloads.com) by clicking the link below



- Please note: If there is no response to CLICKING the link, please download this PDF first and then click on it.

CLICK HERE TO **DOWNLOAD** THE COMPLETE MANUAL

Rear <Brembo disc brake>

Caution

Take care not to contact the parts or tools to the caliper because the paint of caliper will be scratched. And if there is brake fluid on the caliper, wipe out quickly.

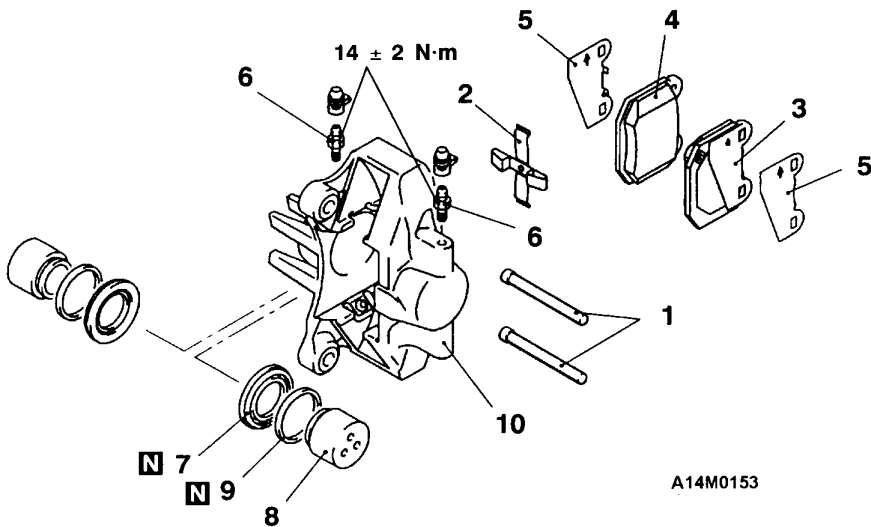

A14M0153

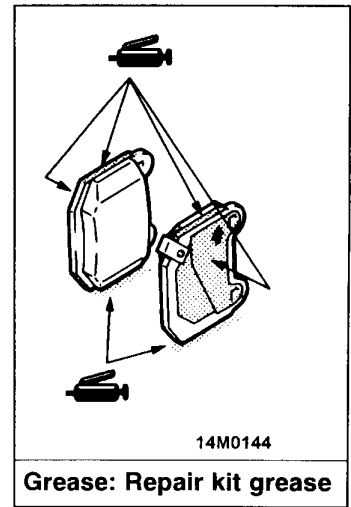

14M0144

Grease: Repair kit grease

<p>A14M0154</p>	<p>A14M0155</p>	<p>A14M0158</p>
<p>Brake caliper kit</p>	<p>Seal and boot kit</p>	<p>Shim set</p>
<p>A14M0156</p>	<p>A14M0157</p>	
<p>Clip set</p>	<p>Pad set</p>	

Disassembly steps

1. Pin
2. Cross spring
3. Pad and wear indicator assembly
4. Pad assembly
5. Shim



6. Air bleeder screw
7. Piston boot
8. Piston
9. Piston seal
10. Caliper body

Code No.32 Longitudinal G sensor system	Probable cause
<p>This code is output in the following cases.</p> <ul style="list-style-type: none"> <li>• If the longitudinal G sensor output voltage is less than 0.5 V or more than 4.5 V &lt;open circuit or short circuit of longitudinal G sensor circuit&gt;</li> <li>• If the longitudinal G sensor output voltage does not change &lt;longitudinal G sensor output voltage: fixed&gt;</li> </ul>	<ul style="list-style-type: none"> <li>• Malfunction of longitudinal G sensor</li> <li>• Malfunction of wiring harness or connector</li> <li>• Malfunction of hydraulic unit and ABS-ECU</li> </ul>

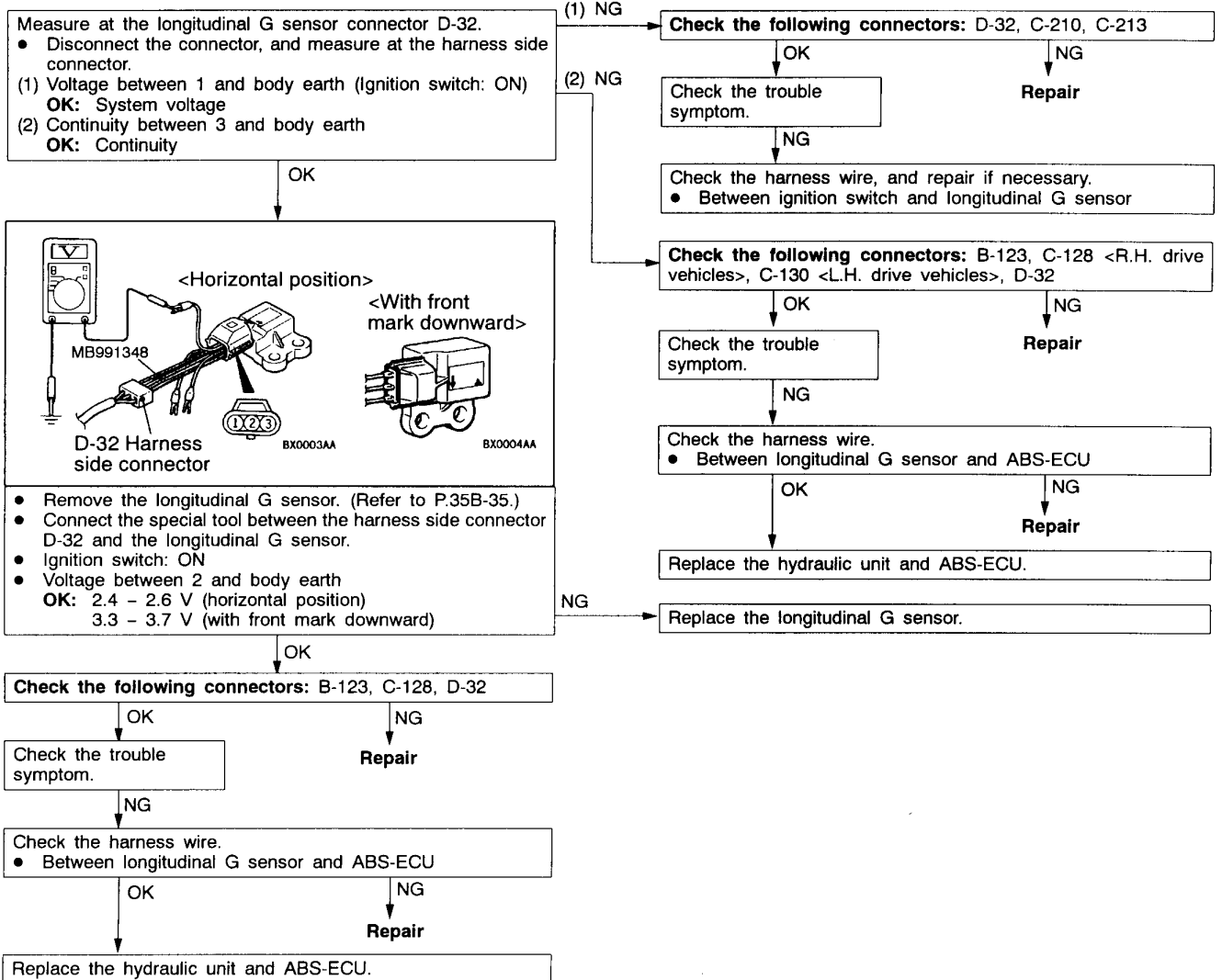

Terminal No.	Check item	Checking requirements		Normal condition
10	ABS-ECU power supply	Ignition switch: ON		System voltage
		Ignition switch: START or ACC		0 V
11	Solenoid valve power supply	Always		System voltage
14	Lateral G sensor input	Ignition switch: ON		2.4 – 2.6 V (horizontal position)
15	Longitudinal G sensor earth	Always		0 V
17	Steering wheel sensor (ST-2) input	Ignition switch: ON	Steering wheel: Turn laterally	Variation in the voltage value 0.8 – 2.1 V and 2.7 – 4.4 V
18	Wheel speed sensor (front right) output	Moving forward slowly		0 – 5 V
19	Stop lamp monitor input	Ignition switch: ON	Stop lamp switch: ON	System voltage
			Stop lamp switch: OFF	1 V or less
20	Wheel speed sensor (rear left) output	Moving forward slowly		0 – 5 V
21	Wheel speed sensor (rear right) output	Moving forward slowly		0 – 5 V
24	Lateral G sensor earth	Always		0 V
25	Longitudinal G sensor input	Ignition switch: ON		2.4 – 2.6 V (horizontal position)
26	Steering wheel sensor (ST-1) input	Ignition switch: ON	Steering wheel: Turn laterally	Variation in the voltage value 0.8 – 2.1 V and 2.7 – 4.4 V
27	ABS warning lamp transistor output	Ignition switch: ON	When the lamp is switched off	1 V or less
			When the lamp is illuminated	7 V or more
32	Wheel speed sensor (front left) output	Moving forward slowly		0 – 5 V
33	Motor power supply	Always		System voltage

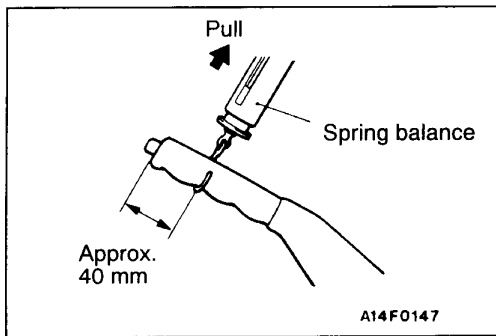

### LINING RUNNING-IN

Carry out running-in by the following procedure when replacing the parking brake linings or the rear brake disc rotors, or when brake performance is insufficient.

#### Caution

**Carry out running-in in a place with good visibility, and pay careful attention to safety.**

1. Adjust the parking brake stroke to the specified value.

**Standard value [Operation force: Approx. 200 N] :  
5 – 7 notches**

2. Hook a spring balance onto the centre of the parking brake lever grip and pull it with a force of 100 – 150 N in a direction perpendicular to the handle.
3. Drive the vehicle at a constant speed of 35 – 50 km/h for 100 metres.
4. Release the parking brake and let the brakes cool for 5 – 10 minutes.
5. Repeat the procedure in steps 2 to 4 four or five times.

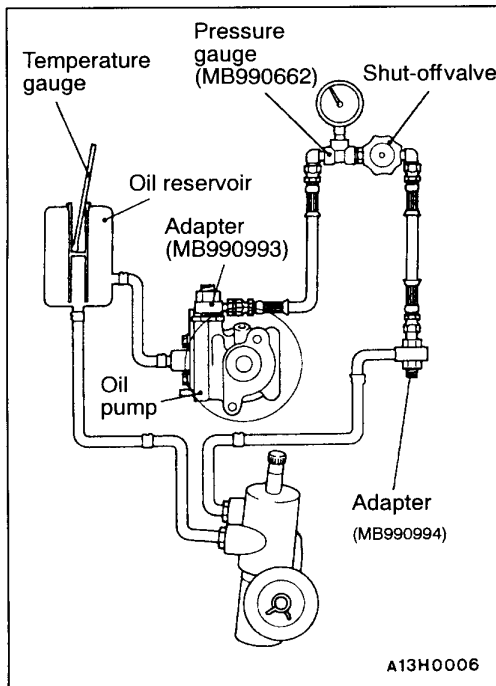
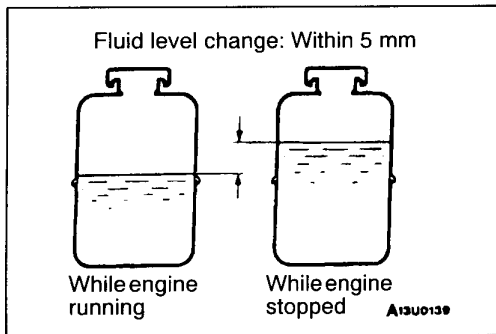

9. If the level changes more than 5 mm, the air is badly bled. So, bleed air again.

#### Caution

- (1) If the fluid level rises suddenly after the engine is stopped, the bleeding is incomplete.
- (2) Incomplete bleeding causes abnormal noises from the pump and the flow-control valve. This could lessen the life of the pump and the other parts.

### OIL PUMP PRESSURE TEST

1. Disconnect the pressure hose from the oil pump, and then connect the special tools.
2. Bleed the air, and then turn the steering wheel several times while the vehicle is not moving so that the temperature of the fluid rises to approximately 50–60°C.
3. Start the engine and idle it at 1,000±100 r/min.
4. Fully close the shut-off valve of the pressure gauge and measure the oil pump relief pressure to confirm that it is within the standard value range.

**Standard value: 8.4 – 9.0 MPa**

5. If the standard value is not met, the oil pump is defective. So, replace the oil pump. Then, measure oil pressure again.
6. With the pressure gauge shut-off valve fully open, check the hydraulic pressure in unladen condition.

**Standard value: 0.2 – 0.8 MPa**

7. If the standard value is not met, the oil line or steering gear is probably defective. So, repair and measure oil pressure again.
8. Turn the steering wheel fully either left or right and check the retention hydraulic pressure.

**Standard value: 8.4 – 9.0 MPa**

9. If the pressure is below the standard value, disassemble and reassemble the steering gear. If above, replace the oil pump. Then, measure oil pressure again.
10. Remove the special tools, and tighten the pressure hose to the specified torque.

**Tightening torque: 18 ± 3 N·m**

11. Bleed the system.

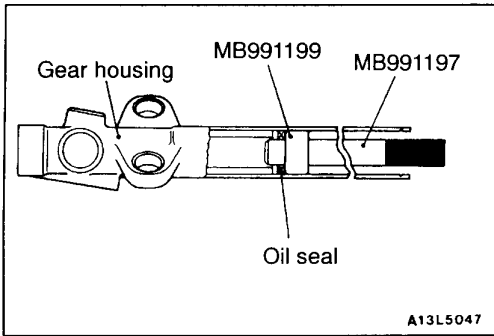

**REASSEMBLY SERVICE POINTS**

**▶A◀ OIL SEAL INSTALLATION**

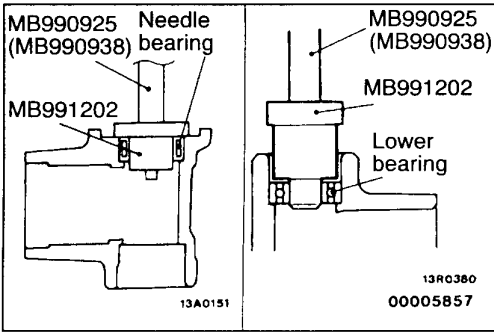

**▶B◀ NEEDLE BEARING/LOWER BEARING INSTALLATION**

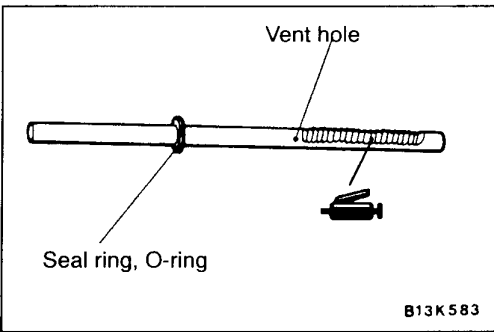

**▶C◀ RACK ASSEMBLY INSTALLATION**

1. Apply repair kit grease to the teeth of the rack assembly.

**Caution**

Use care not to close the vent hole in the rack with grease.

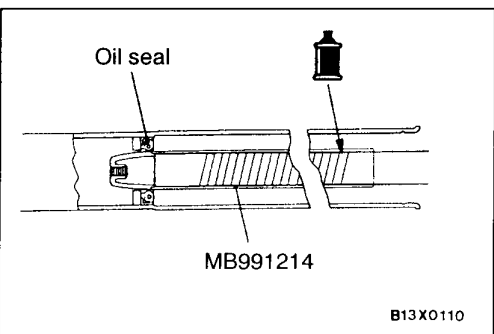

2. Cover the serrations of the rack assembly with the special tool.
3. Apply specified fluid to the outer surfaces of the special tool, seal ring and O-ring.

**Specified fluid:**

**Automatic transmission fluid DEXRON II**

**Caution**

Do not use ATF-SP II M and ATF-SP III.

4. Slowly insert the rack covered with the special tool from the power cylinder side of the gear housing.

**Caution**

Carefully push in the rack with the oil seal centre and the special tool end matched. This is to avoid the retainer spring coming off.

# FENDER

## REMOVAL AND INSTALLATION

**Pre-removal and Post-installation Operations**

- Front Bumper Removal and Installation (Refer to GROUP 51.)
- Front Deck Garnish Removal and Installation (Refer to GROUP 51.)

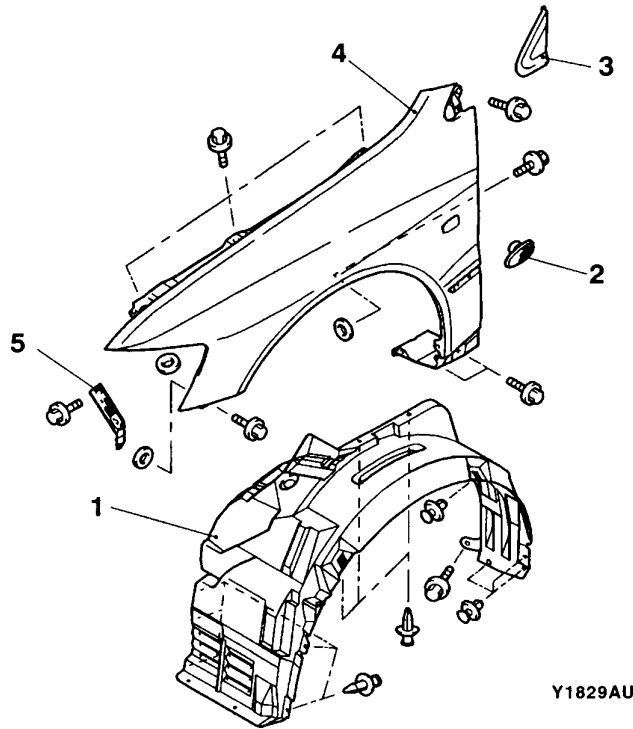

Y1829AU

**Removal steps**

- Side air dam (Refer to GROUP 51.)
1. Splash shield
  2. Side turn signal lamp (Refer to GROUP 54A.)



3. Deck garnish (Refer to GROUP 51-Windshield Wiper and Washer)
4. Fender
5. Front fender bracket

# DOORS

## SERVICE SPECIFICATIONS

Items	Standard value	
Door outside handle play mm	Front	2.3 ± 2.1
	Rear	1.3 ± 1.7
Power window operating current (power supply 14.5 ± 0.5 V, 25°C) A	5 ± 1	
Door inside handle play mm	Front	9.6 ± 9.2
	Rear	9.0 ± 9.2

## ADHESIVE

Items	Specified sealant	Remark
Waterproof film	3M ATD Part No. 8625 or equivalent	Ribbon sealer

## SPECIAL TOOLS

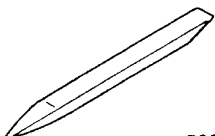
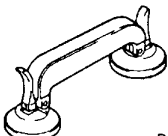
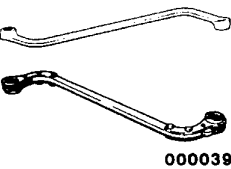
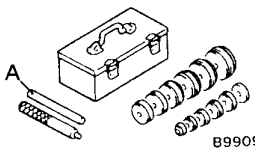
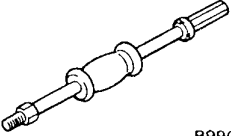
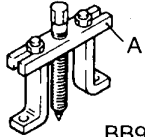
Tool	Number	Name	Use
 B990784	MB990784	Ornament remover	Door trim removal
 B990480	MB990480	Window glass holder	Removal of power window regulator and motor assembly
 00003936	MB990900 or MB991164	Door hinge adjusting wrench	Adjustment of door fit
 B990925	MB990925 A: MB990939	Bearing & oil seal installer set A: Brass bar	Adjustment of door striker
 B990211	MB990211	Slide hammer	
 BB990241	MB990241 A: MB990243	Axle shaft puller A: Body puller	

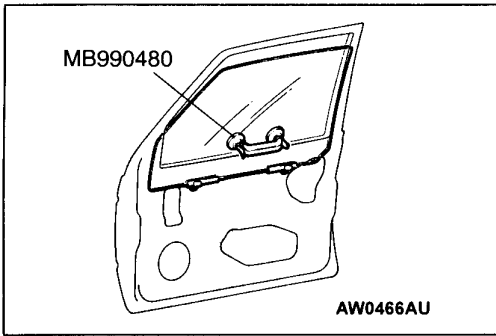

**REMOVAL SERVICE POINTS**

**◀A▶ WINDOW REGULATOR ASSEMBLY/POWER WINDOW MOTOR ASSEMBLY REMOVAL**

1. Loosen the door window glass assembly mounting bolts.
2. Raise the door window glass assembly, and then adhere the special tool on the glass as shown in the illustration to prevent from falling.

**Caution** For the door window glass adhered film and etc., use the special tool from outside the door glass to prevent unsticking.

3. Remove the power window regulator and motor assembly.

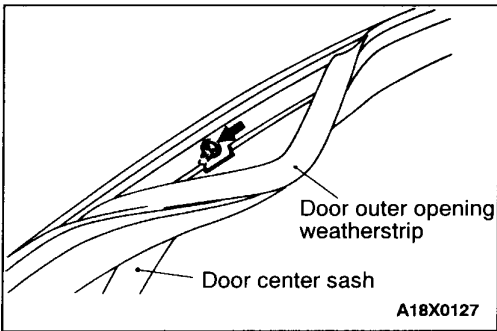

**◀B▶ DOOR CENTER SASH REMOVAL**

1. Remove only the section of the door outer opening weatherstrip
2. Remove the center sash upper mounting screws, and then remove the center sash upper from the door panel.

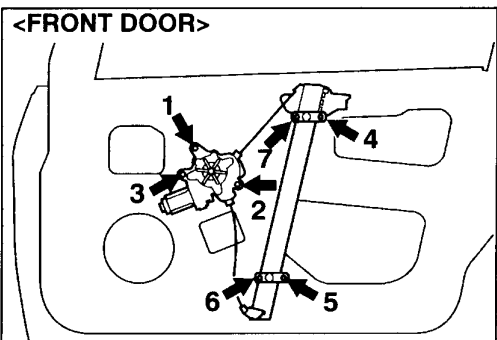

**INSTALLATION SERVICE POINTS**

**▶A◀ WINDOW REGULATOR ASSEMBLY/POWER WINDOW MOTOR ASSEMBLY INSTALLATION**

When installing the window regulator assembly, tighten the bolts at the specified torque in the order shown in the illustration.

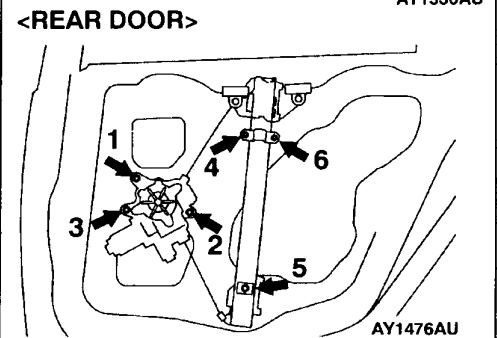

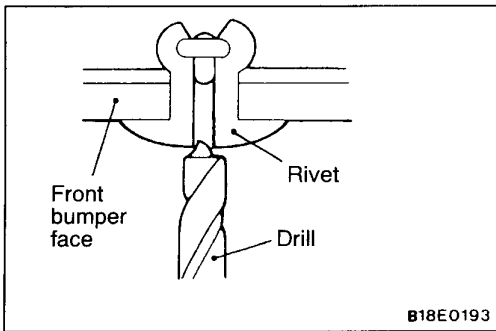
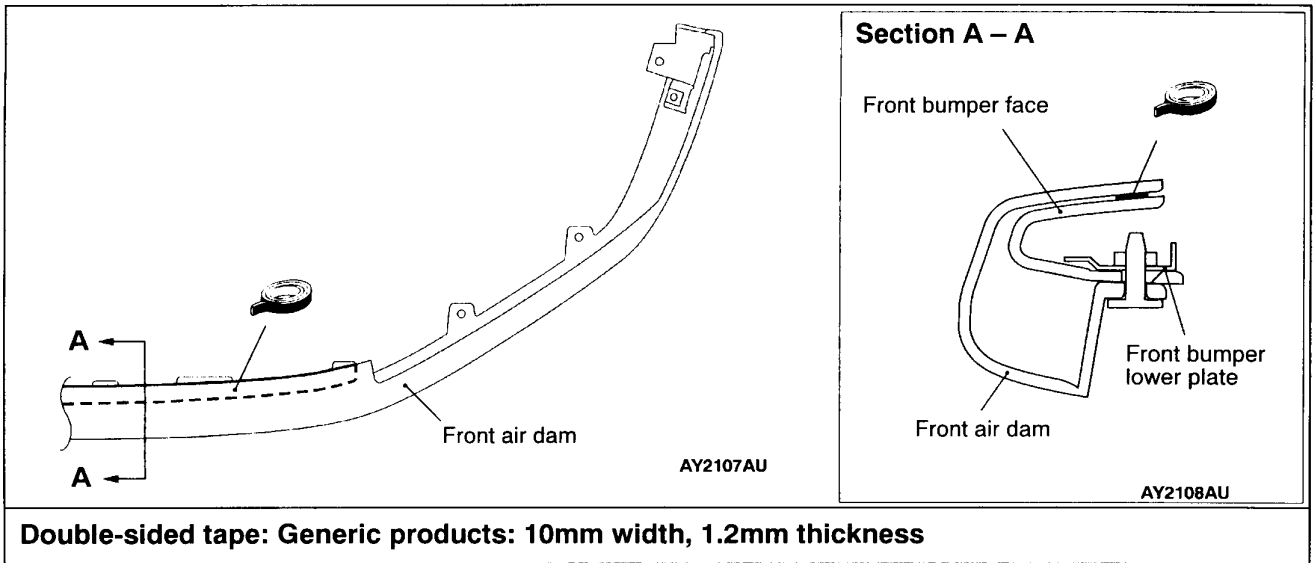

**DISASSEMBLY SERVICE POINTS**

**◀A▶ RIVET REMOVAL**

Use the drill (ø4.0 mm) to make a hole in the rivet for removal.

**◀B▶ FRONT AIR DAM REMOVAL**

The same procedures are applied as that of the removal of side air dam. (Refer to P.51-10.)

**REASSEMBLY SERVICE POINTS**

**▶A◀ FRONT AIR DAM INSTALLATION**

The same procedures are applied as that of the installation of side air dam. (Refer to P.51-10.)

**WINDSHIELD WASHER NOZZLE INJECTION POSITION CHECK**

Move the nozzle to adjust the position so that the injection can be done in an area shown in the illustration.

**Caution**

**On R.H. drive vehicles, the illustration is symmetrical.**

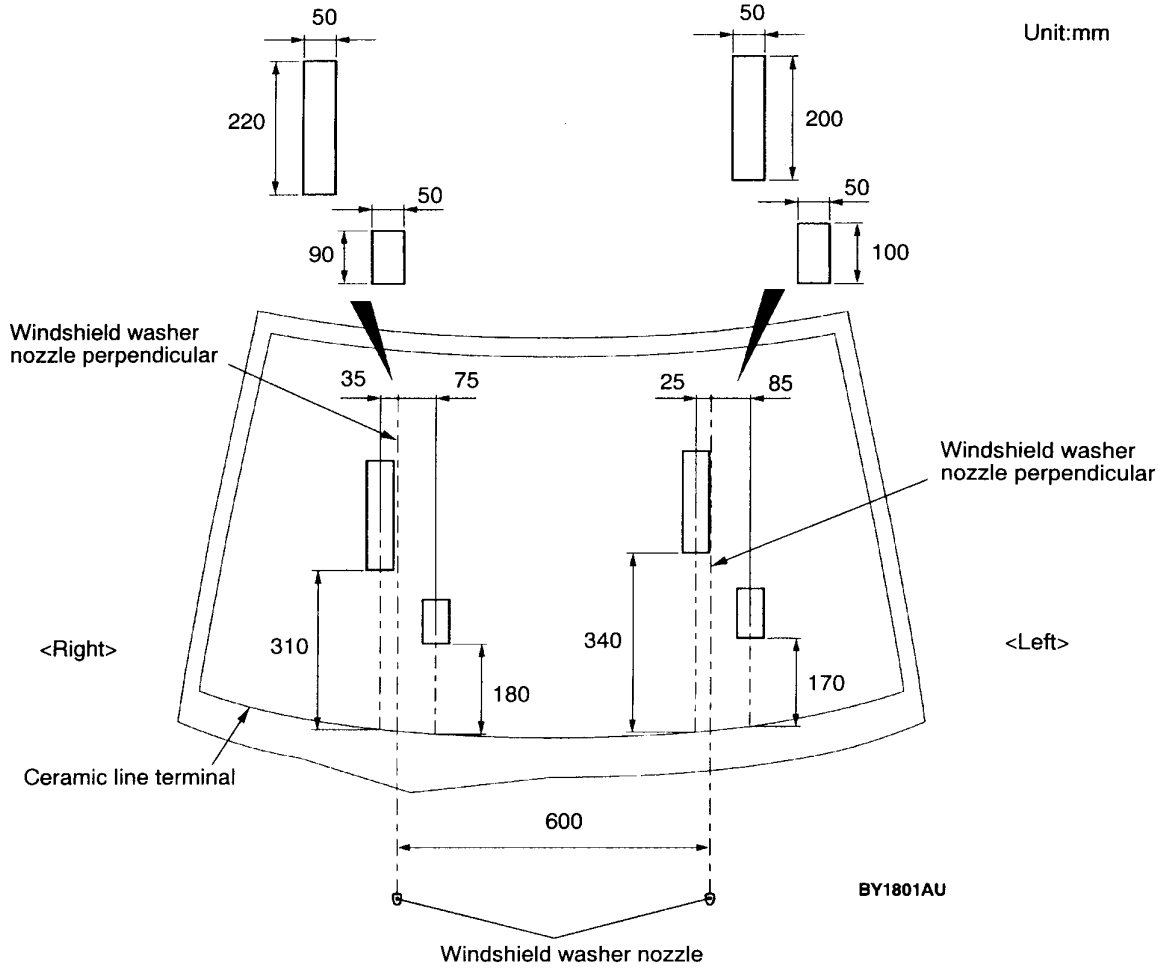

<R.H. DRIVE VEHICLE>

**Caution: SRS**

1. Refer to GROUP 52B-SRS Service Precautions and Air bag Module and Clock Spring before removing the passenger side air bag module.
2. Do not subject the SRS-ECU to any shocks when removing or installing the instrument panel.

**Pre-removal and Post-installation Operation**

- Removal and Installation of Front Pillar Trim (Refer to P.52A-15.)
- Food Opener Lever (Refer to GROUP42.)

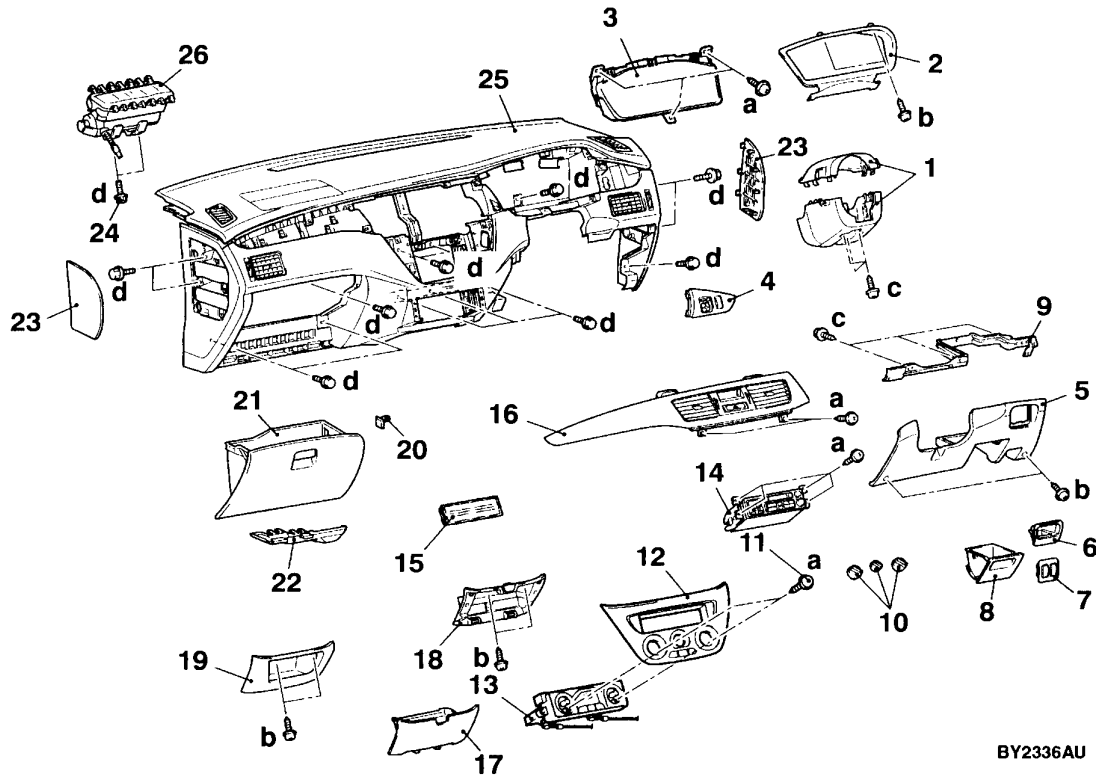

BY2336AU

**Removal steps**

- |   |   |
|---|---|
| <ol style="list-style-type: none"> <li>1. Column cover</li> <li>2. Meter bezel</li> <li>3. Combination meter</li> <li>4. Instrument panel ornament</li> <li>5. Under cover</li> <li>6. Box &lt;Vehicle with box&gt;</li> <li>7. Switch panel &lt;Vehicle with switch panel&gt;</li> <li>8. Side box</li> <li>9. Lower frame</li> <li>10. Heater control knob</li> <li>11. Heater control assembly mounting screw</li> <li>12. Center panel</li> <li>13. Heater control panel assembly</li> <li>14. Radio and tape player</li> </ol> | <ol style="list-style-type: none"> <li>15. Plug &lt;Vehicle without radio and tape player&gt;</li> <li>16. Center air outlet panel</li> <li>17. Center lower box A &lt;RS- II &gt;</li> <li>18. Center lower case A &lt;RS- II &gt;</li> <li>19. Center lower box B &lt;RS&gt;</li> <li>20. Stopper</li> <li>21. Glove box</li> <li>22. Harness cover</li> <li>23. Instrument panel side cover</li> <li>24. SRS front passenger's air bag module mounting bolt                     <ul style="list-style-type: none"> <li>• Steering column shaft mounting bolt (Refer to GROUP37A – Steering Wheel and Shaft.)</li> </ul> </li> <li>25. Instrument panel assembly</li> <li>26. SRS front passenger's air bag module</li> </ol> |
|---|---|



RECARO SEAT

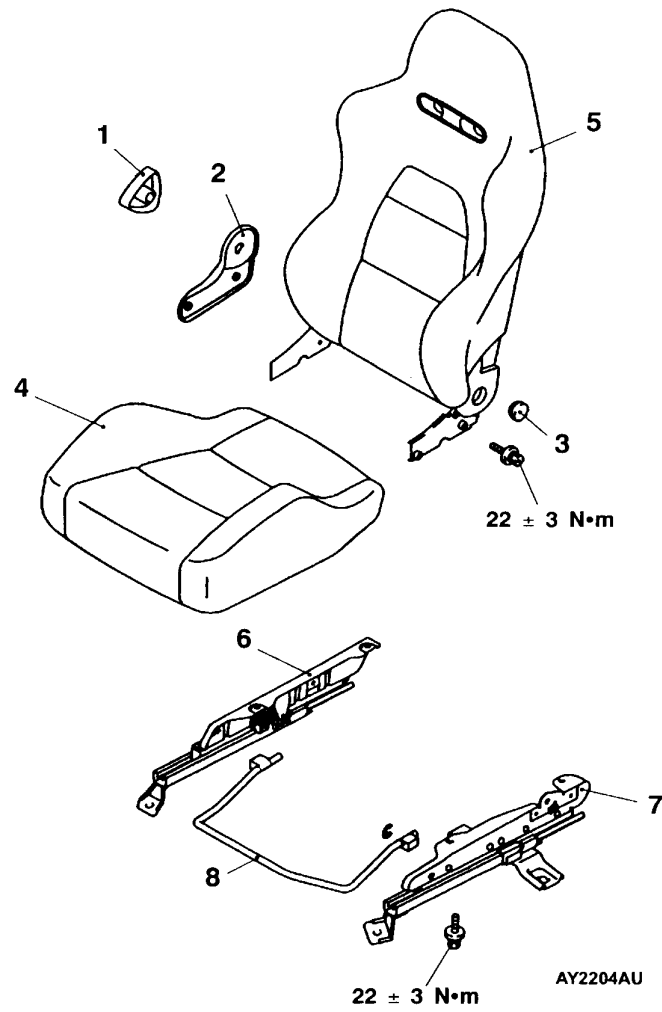

**Disassembly steps**

- |                                |                             |
|--------------------------------|-----------------------------|
| 1. Reclining knob              | 5. Front seat back assembly |
| 2. Reclining cover             | 6. Seat rail R.H.           |
| 3. Cap                         | 7. Seat rail L.H.           |
| 4. Front seat cushion assembly | 8. Seat slide lever         |

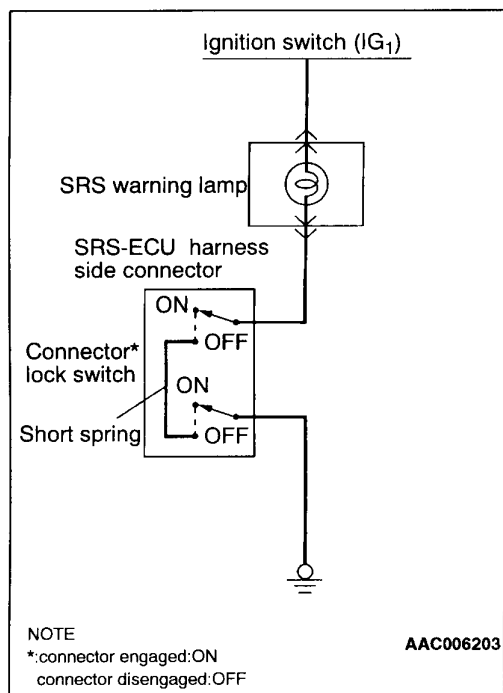
**WARNING LAMP CIRCUIT CONNECTOR LOCK SWITCH**

Mechanism to automatically short-circuit the power supply terminal and the earth terminal of the warning lamp circuit when the SRS-ECU connector is disconnected. The structure is the same as that of squib circuit connector lock switch.

**INSPECTION CHART FOR DIAGNOSIS CODES**

Inspect according to the inspection chart that is appropriate for the malfunction code.

Code no.	Diagnostic item	Page	
14	SRS-ECU front impact analog G-sensor system	52B-11	
15	SRS-ECU front impact safing G-sensor system	Short circuit in the sensor Open circuit in the sensor	
16	SRS-ECU front impact safing G-sensor system		
21* <sup>1</sup>	Driver's air bag module (squib) system	Short circuit between terminals of the squib circuit	52B-12
22* <sup>1</sup>	Driver's air bag module (squib) system	Open in the squib circuit	52B-16
24* <sup>1</sup>	Front passenger's air bag module (squib) system	Short circuit between terminals of the squib circuit	52B-20
25* <sup>1</sup>	Front passenger's air bag module (squib) system	Open in the squib circuit	52B-22
26* <sup>1</sup>	Driver's seat belt pre-tensioner (squib) system	Short circuit between terminals of the squib circuit	52B-23
27* <sup>1</sup>	Driver's seat belt pre-tensioner (squib) system	Open in the squib circuit	52B-25
28* <sup>1</sup>	Front passenger's seat belt pre-tensioner (squib) system	Short circuit between terminals of the squib circuit	52B-26
29* <sup>1</sup>	Front passenger's seat belt pre-tensioner (squib) system/	Open in the squib circuit	52B-28
31	SRS-ECU DC-DC converter system	Increased terminal voltage	52B-11
32	SRS-ECU DC-DC converter system	Decreased terminal voltage	

Code No.26 Driver's seat belt pre-tensioner (squib) system	Possible Cause
This code is output when short circuit occurs between terminals of the SRS-ECU driver's seat belt pre-tensioner (squib) circuit. However, SRS warning lamp goes out when a normal operation is resumed (diagnosis code is not cleared.)	<ul style="list-style-type: none"> <li>● Connector engagement faulty or short bar faulty*</li> <li>● Short circuit between terminals of the driver's seat belt pre-tensioner (squib) circuit</li> <li>● Faulty connector</li> <li>● SRS-ECU inoperable</li> </ul>

**NOTE:**

\*: The connector of the squib circuit contains a short bar (short-circuiting the positive (+) cable and the negative (-) cable to avoid an erroneous deployment caused by static electricity when a connector is not connected). Thus, when a connector is connected, the short bar may not be released due to improper engagement of the connector or faulty connector as shown in the illustration below. Disconnect the connector as shown in the illustration below, then reconnect it. Check that a diagnosis code is output again after erasing the memory. If the diagnosis code is not output, the above-mentioned code is output due to improper engagement of the connector.

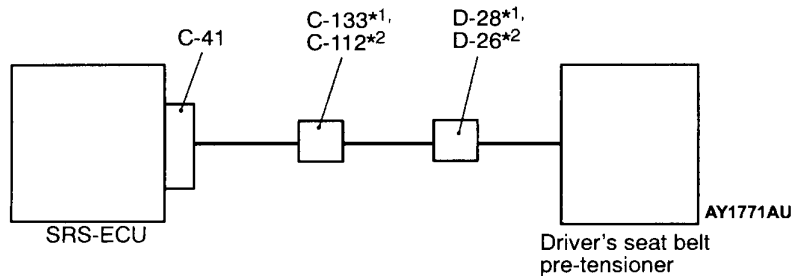
**NOTE**

\*1: L.H. drive vehicles

\*2: R.H. drive vehicles

From Previous Page

YES (when No.61 is output)

**<Check the circuit between the SRS-ECU and clock spring>**  
 Measure at the SRS-ECU connector C-21.

- Disconnect the SRS-ECU connector C-21.
- Disconnect the the clock spring connector C-204.
- Ignition switch:ON
- Measure at the harness side
- Voltage between terminal 11 or 12 and body earth

**Caution**  
 Do not directly insert a probe or other devices at the front of the connector to avoid a possible decrease in the contact pressure.

OK: 0 V

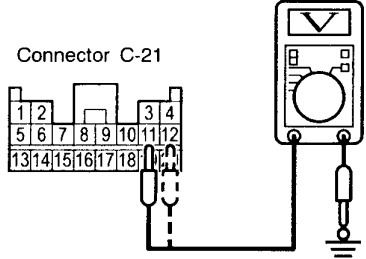

Connector C-21

Y1736AU

YES (when No.62 is output)

**<Check the circuit between the SRS-ECU and clock spring>**  
 Measure at the SRS-ECU connector C-21.

- Disconnect the SRS-ECU connector C-21.
- Disconnect the clock spring connector C-204 .
- Measure at the harness side
- Continuity between terminal 11 or 12 and body earth

**Caution**  
 Do not directly insert a probe or other devices at the front of the connector to avoid a possible decrease in the contact pressure.

OK: No continuity

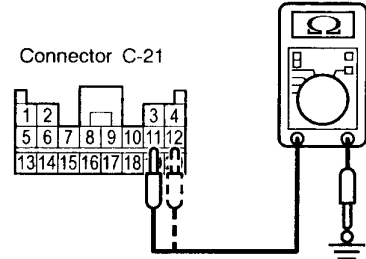

Connector C-21

Y1737AU

OK → Replace the SRS-ECU.

OK

NG

NG

NG

Correct

Replace the SRS-ECU.

Check connector: C-21, C-204

Check the trouble symptoms.

Check the harness between the clock spring and the SRS-ECU, and repair if necessary.

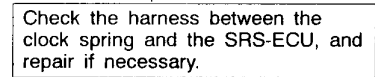
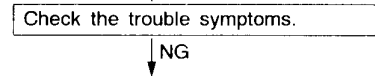
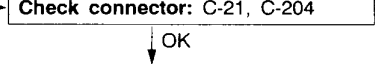
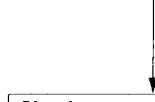

**INSTALLATION SERVICE POINTS****▶A◀ SRS-ECU INSTALLATION****Caution**

Be sure to install the SRS-ECU properly. Otherwise, the SRS air bags do not activate, which results in serious injury or death of vehicle's occupants.

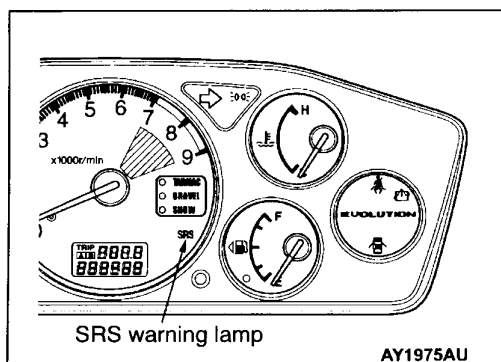
**▶B◀ POST-INSTALLATION CHECK**

1. Turn the ignition switch to ON.
2. Does the SRS warning lamp illuminate for about 7 seconds and then go out.

Yes: The SRS warning lamp is working properly  
No: Go to Troubleshooting. (Refer to P.52B-6.)

**INSPECTION**

1. Check the SRS-ECU and brackets for dents, cracks or deformation.
2. Check connector for damage, and terminals for deformation.

**Caution**

If a dent, crack, deformation or rust are present, replace the SRS-ECU with a new one.

**NOTE**

To check the SRS-ECU in other items than described above, go to Troubleshooting. (Refer to P.52B-6.)

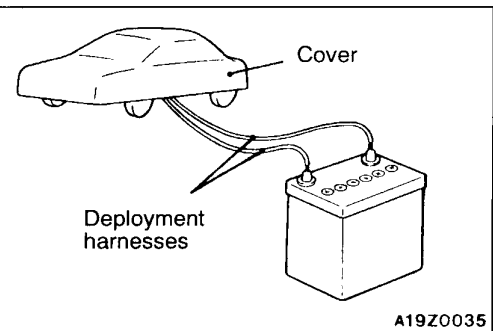
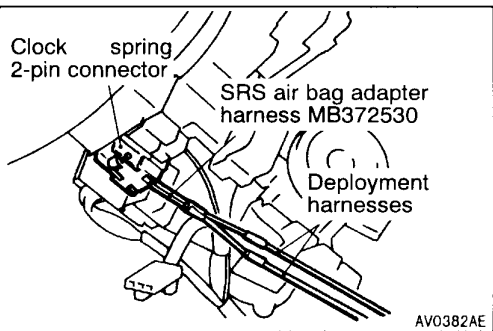
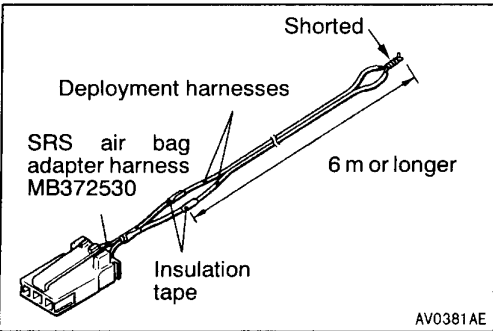
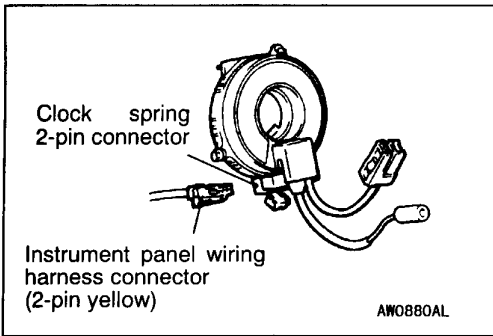

### Driver's air bag module

- (1) Remove the steering column cover, lower.  
(Refer to GROUP 52A – Instrument Panel.)
- (2) Disconnect the clock spring 2-pin connector and instrument panel wiring harness connector (2-pin, yellow).

#### NOTE

Once disconnected from the instrument panel wiring harness, both electrodes of the clock spring connector short automatically. This prevents the driver's air bag from accidental deployment caused by static, etc.

- (3) Connect deployment harnesses longer than 6 m to each SRS air bag adapter harness and insulate the connections with plastic tape.  
Also, connect the deployment harnesses in the other ends to short, thereby preventing the driver's air bag from accidental deployment caused by static etc.

- (4) Connect the SRS air bag adapter harness to the clock spring 2-pin connector and route the deployment harnesses out of the vehicle.

- (5) Close all the doors with the windows fully closed and put a cover over the vehicle to minimize report.

#### Caution

**The cover is required as the glass, if already damaged, may break.**

- (6) Separate the deployment harnesses as far from the vehicle as possible and connect to the terminals of the battery removed from the vehicle. Then deploy.

#### Caution

- 1) **Before deploying the air bag, see that no one is in and near the vehicle. Also, put on safety glasses.**
- 2) **The deployment makes the inflator of the driver's air bag very hot. Before handling the inflator, wait more than 30 minutes for cooling.**
- 3) **If the driver's air bag module fails to deploy although the procedure is respected, do not go near the module. Contact your local distributor.**

- (7) Discard the deployed air bag module according to Deployed Air Bag Module Disposal Procedures. (Refer to P.52B-75.)

# BATTERY

## SERVICE SPECIFICATION

Item	Specification
Specific gravity of the battery fluid	1.220 – 1.290 [20°C]

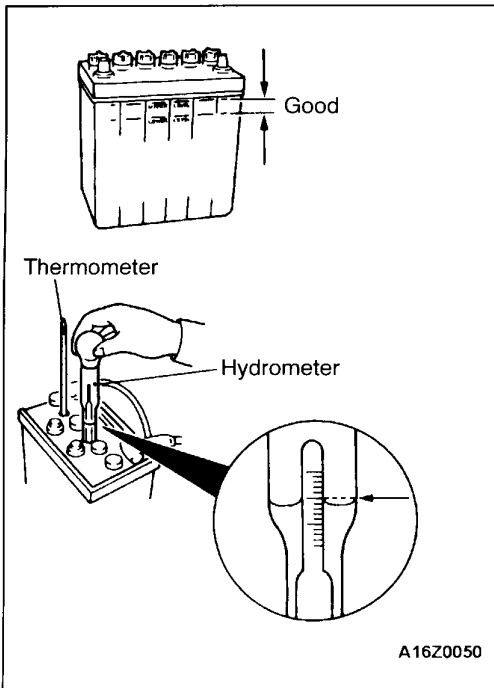

## ON-VEHICLE SERVICE

### FLUID LEVEL AND SPECIFIC GRAVITY CHECK

1. Inspect whether or not the battery fluid is between the UPPER LEVEL and LOWER LEVEL marks.

**Caution**

- (1) If the battery fluid is below the LOWER LEVEL, the battery could explode in using.
- (2) If the battery fluid is over the UPPER LEVEL, leakage could result.

2. Use a hydrometer and thermometer to check the specific gravity of the battery fluid.

**Standard value: 1.220 – 1.290 [20°C]**

The specific gravity of the battery fluid varies with the temperature, so use the following formula to calculate the specific gravity for 20°C. Use the calculated value to determine whether or not the specific gravity is satisfactory.

$$D20 = (t - 20) \times 0.0007 + Dt$$

**D20: Specific gravity of the battery fluid calculated for 20°C.**

**Dt: Actually measured specific gravity**

**t: Actually measured temperature**

## CHARGING

1. Remove the battery from the vehicle.
2. The normal charging current is a value in amperes which is 1/10th of the battery capacity. If the battery needs to be charged rapidly because of reasons such as time limitations, the maximum charging current for rapid charging is the battery capacity expressed as an ampere value.

Battery type	Capacity (5-hour rate)	Normal charging current	Rapid charging current
44B20	34 A	3.4 A	34 A

3. Determine when charging is finished.
  - When the specific gravity of the battery electrolyte is constantly within 1.250 – 1.290 for a continuous period of one hour or more
  - When the voltage per cell during charging is 2.5 – 2.8 V constantly for a continuous period of one hour or more

Inspection procedure 4

Water temperature gauge inoperative (other meters are operated)	Probable cause
When speedometer and tachometer are properly operated, harness from power source to combination meter is normal.	<ul style="list-style-type: none"> <li>• Water temperature gauge unit fault</li> <li>• Harness or connector fault</li> <li>• Meter assembly fault</li> </ul>

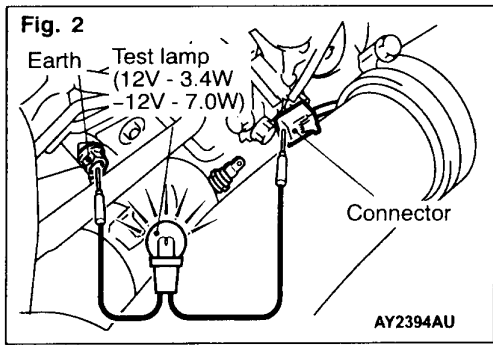
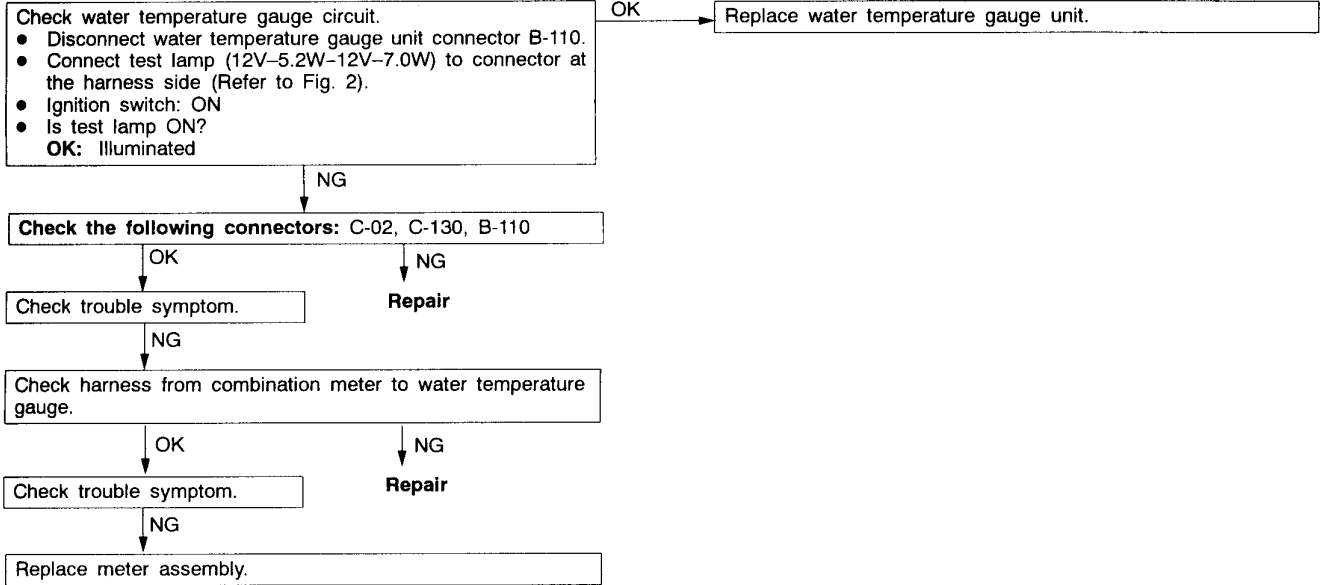

# REAR COMBINATION LAMP

## SPECIAL TOOL

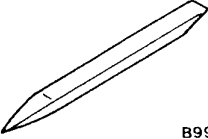
Tool	Number	Name	Use
 B990784	MB990784	Ornament remover	Rear combination lamp removal

## TROUBLESHOOTING

For troubleshooting on rear combination lamps, refer to GROUP 54B.

## REAR COMBINATION LAMP

### REMOVAL AND INSTALLATION

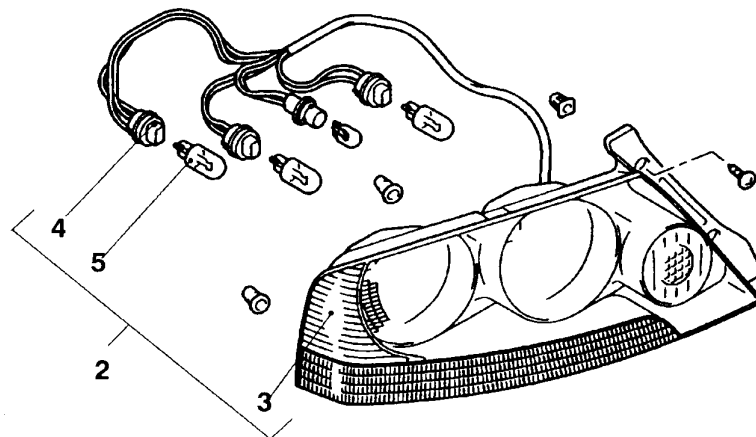
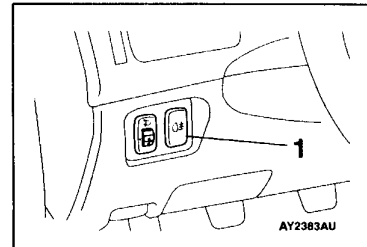
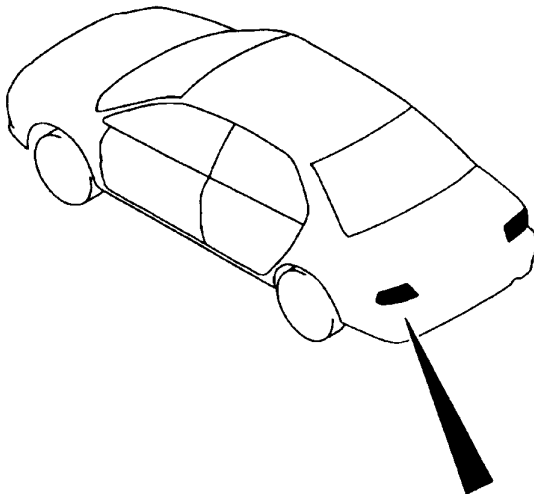

AY2156AU

1. Rear fog lamp switch

#### Removal steps

2. Rear combination lamp assembly
3. Rear combination lamp body

4. Socket assembly
5. Bulb

**INPUT SIGNAL CHECK**

1. Check the inputs using MUT-II or a voltmeter. (Refer to GROUP 00 – How to Use Troubleshooting/Inspection Service Points.)
2. The following input signals can be checked using MUT-II or a voltmeter connected to the diagnosis connector.

**NOTE**

When fault is detected during input signal inspection, refer to Trouble Symptom Chart to perform troubleshooting. (Refer to P.54B-7).

**Input Signal Check Function**

Input signal		Buzzer operation condition
Ignition switch (ACC)		When ignition switch turned from "LOCK" (OFF) to ACC.
Ignition switch (IG1)		When ignition switch turned from "ACC" to "ON".
Hazard warning lamp switch		When switch turned from OFF to ON.
Rear fog lamp switch		
Driver's door switch		When driver's door opened from closed
All door switches		When any door opened when all doors were closed.
Driver's door lock actuator		When the driver's side key cylinder or inside lock knob is moved from the locked to unlocked position or vice versa.
Vehicle speed signal		Vehicle speed changes from less than 10 km/h to 10 km/h or more.
Column switches	Tail lamp switch	When lighting switch turned from automatic lighting to tail lamp position.
	Headlamp switch	When lighting switch turned from tail lamp to headlamp position.
	Dimmer switch	When switch turned from OFF to ON.
	Passing switch	
	Left-hand turn signal lamp switch	
	Right-hand turn signal lamp switch	
	Windshield mist wiper switch	
	Windshield wiper intermittent timing switch	
	Windshield wiper LO speed switch	
	Windshield wiper HI speed switch	
	Windshield washer switch	When switch turned from OFF to ON.
Power window main switch	All switches	When switch turned from OFF to ON.

**DIAGNOSIS CODE CHART**

Code No.	Diagnosis item	Reference page
11	ETACS-ECU-related failure	54B-4
12	Column switch-related failure or fault in connecting to ETACS-ECU	54B-4
13	Front-ECU-related failure or fault in connecting to ETACS-ECU	54B-5
21	Short circuit in communication lines	54B-6

**Inspection Procedure E-1**

The windshield wipers do not work at all.	Probable cause
Either the windshield wiper motor, the column switch, or the front-ECU may be defective.	<ul style="list-style-type: none"> <li>● Windshield wiper motor fault</li> <li>● Column switch fault</li> <li>● front-ECU fault</li> <li>● Harness or connector fault</li> </ul>

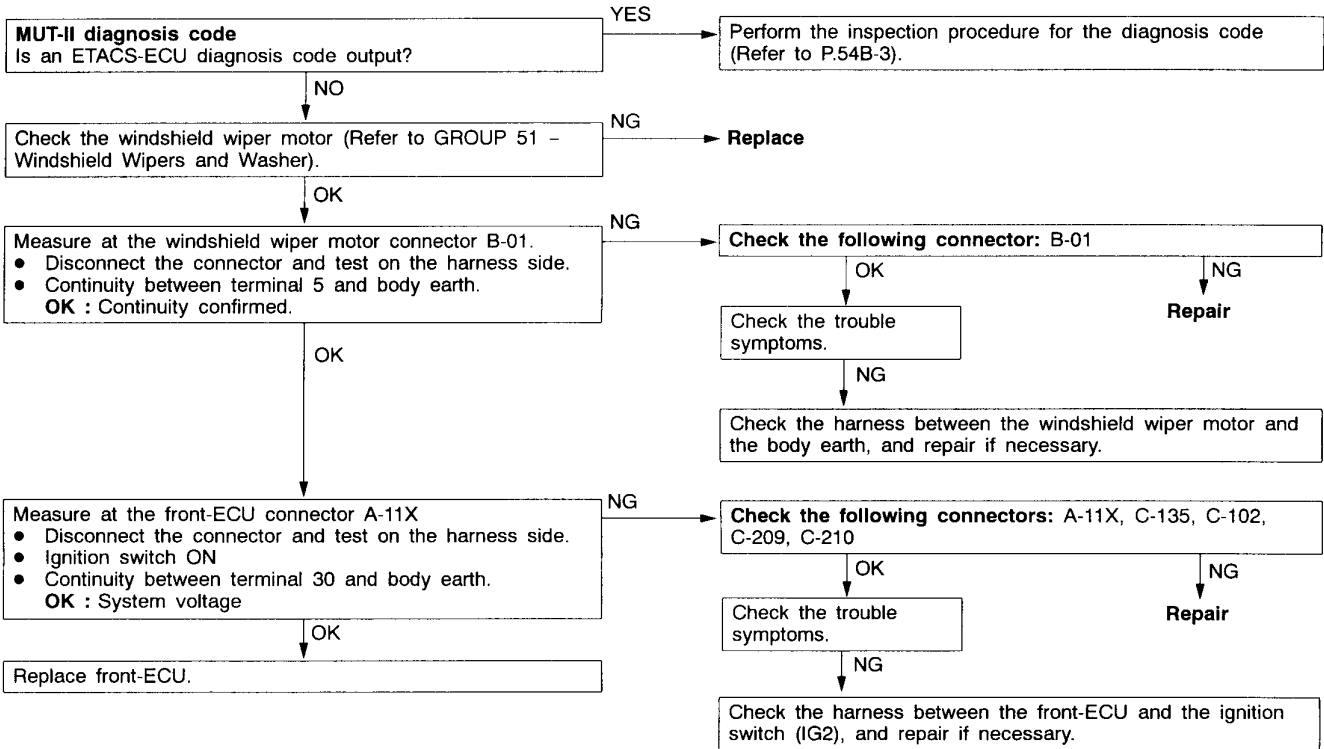

**Inspection Procedure E-2**

The windshield wipers only operate at LO speed (though the wipers and washer can be switched OFF).	Probable cause
If the windshield wipers only operate at LO speed regardless of the switch position, the windshield wiper fail-safe function is probably activated. Or the ETACS-ECU ignition switch (ACC) signal may be controlling the wiper operation.	<ul style="list-style-type: none"> <li>● Column switch fault</li> <li>● front-ECU fault</li> <li>● Harness or connector fault</li> </ul>

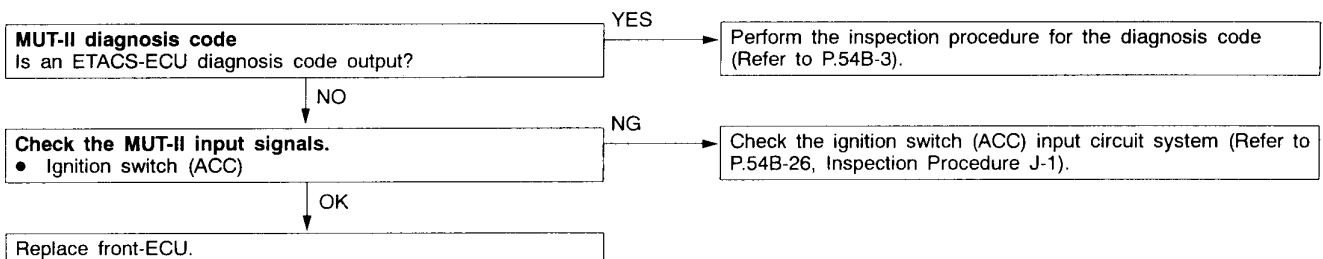

**Inspection Procedure J-7**

<p><b>Column switches:</b></p> <ul style="list-style-type: none"> <li>● No tail lamp switch signal input to ETACS-ECU.</li> <li>● No headlamp switch signal input to ETACS-ECU.</li> <li>● No dimmer switch signal input to ETACS-ECU.</li> <li>● No passing switch signal input to ETACS-ECU.</li> <li>● No turn signal lamp left-hand switch signal input to ETACS-ECU.</li> <li>● No turn signal lamp right-hand switch signal input to ETACS-ECU.</li> </ul>	<p><b>Probable cause</b></p>
<p>As the (lighting) column switch input signals control the operation of the following functions, any abnormality in the signals prevents these functions operating normally.</p> <ul style="list-style-type: none"> <li>● Lights left ON reminder warning function</li> <li>● Headlamps, tail lamps</li> <li>● Turn signal lamps</li> </ul>	<ul style="list-style-type: none"> <li>● Column switch fault</li> <li>● ETACS-ECU fault</li> <li>● Harness or connector fault</li> </ul>

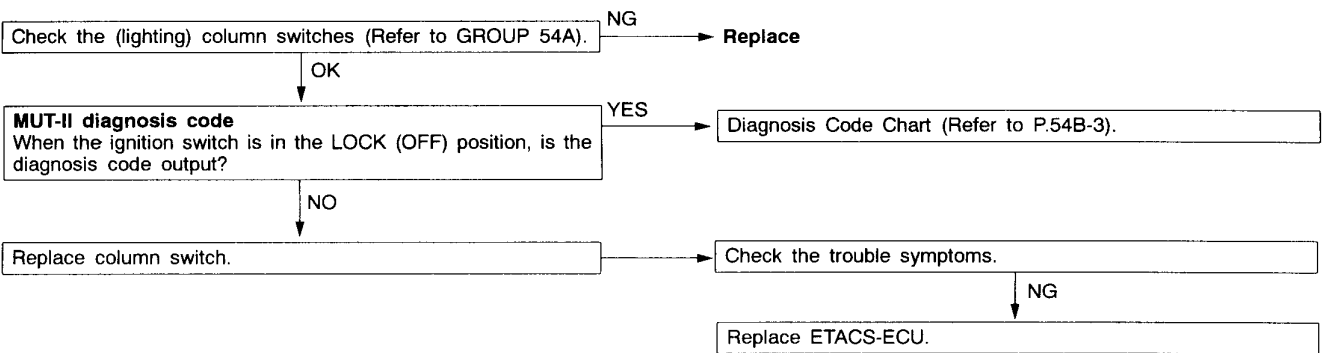

**Inspection Procedure J-8**

<p><b>Column switches:</b></p> <ul style="list-style-type: none"> <li>● No windshield mist wiper switch signal input to ETACS-ECU.</li> <li>● No windshield wiper intermittent switch signal input to ETACS-ECU.</li> <li>● No windshield low-speed wiper switch signal input to ETACS-ECU.</li> <li>● No windshield high-speed wiper switch input to ETACS-ECU.</li> <li>● No windshield washer switch signal input to ETACS-ECU.</li> </ul>	<p><b>Probable cause</b></p>
<p>As the column switch (wiper/washer switch) input signal is used to control the following functions, any failure prevents these functions from operating properly.</p> <ul style="list-style-type: none"> <li>● Windshield wiper and washer</li> </ul>	<ul style="list-style-type: none"> <li>● Column switch fault</li> <li>● ETACS-ECU fault</li> <li>● Harness or connector fault</li> </ul>

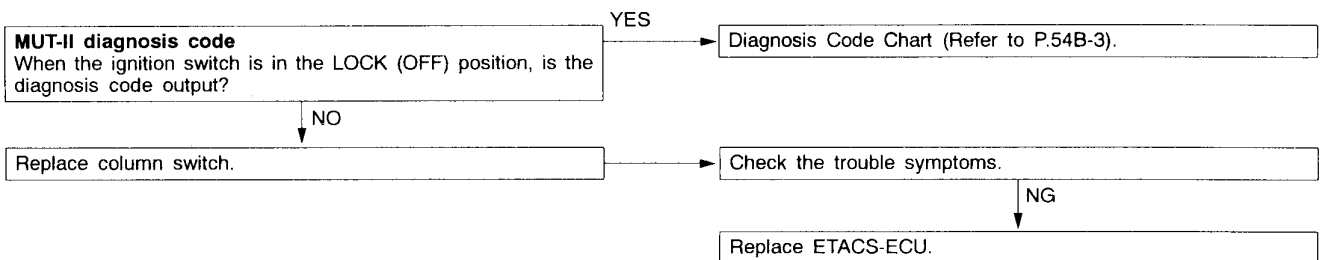

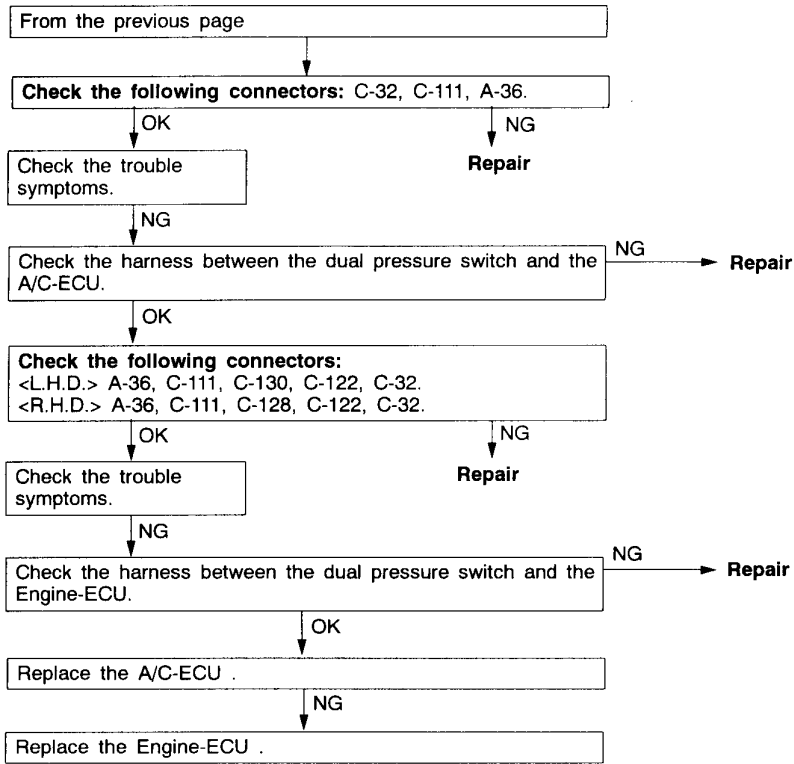

**Inspection procedure 6**

<b>Magnet clutch not working normally</b>	<b>Probable cause</b>
If the magnet clutch does not work normally, the field core or the compressor may be defective.	<ul style="list-style-type: none"> <li>● Compressor fault</li> <li>● Field core fault</li> </ul>

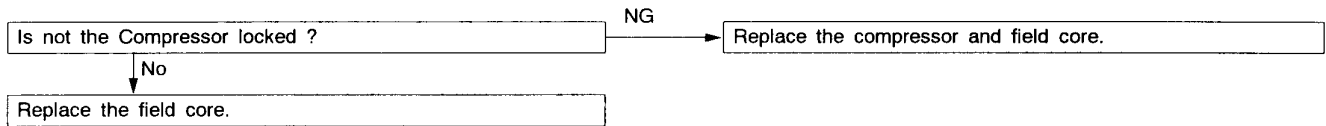

<L.H. drive vehicle>

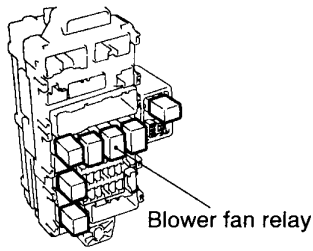

AY1457AU

<R.H. drive vehicle>

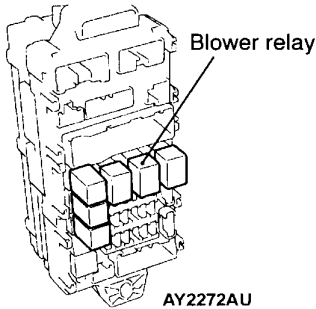

AY2272AU

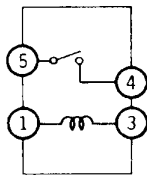
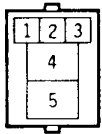

04Z0001

**BLOWER RELAY CONTINUITY CHECK**

System voltage	Terminal No.			
	1	3	4	5
When current is not supplied	○	○		
When current is supplied	⊕	⊖	○	○

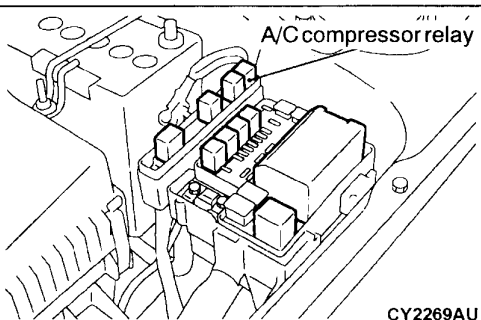

CY2269AU

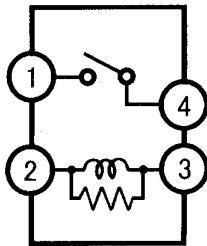
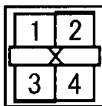

Y0818AU

**A/C COMPRESSOR RELAY CONTINUITY CHECK**

System voltage	Terminal No.			
	3	2	1	4
When current is not supplied	○	○		
When current is supplied	⊕	⊖	○	○

# COMPRESSOR

## REMOVAL AND INSTALLATION

**Before Removal**  
Refrigerant Draining (Refer to P.55-19.)

**After Removal**

- Refrigerant Replenishing (Refer to P.55-16.)
- Drive Belt Tension Check (Refer to GROUP 11A – Engine Adjustment.)

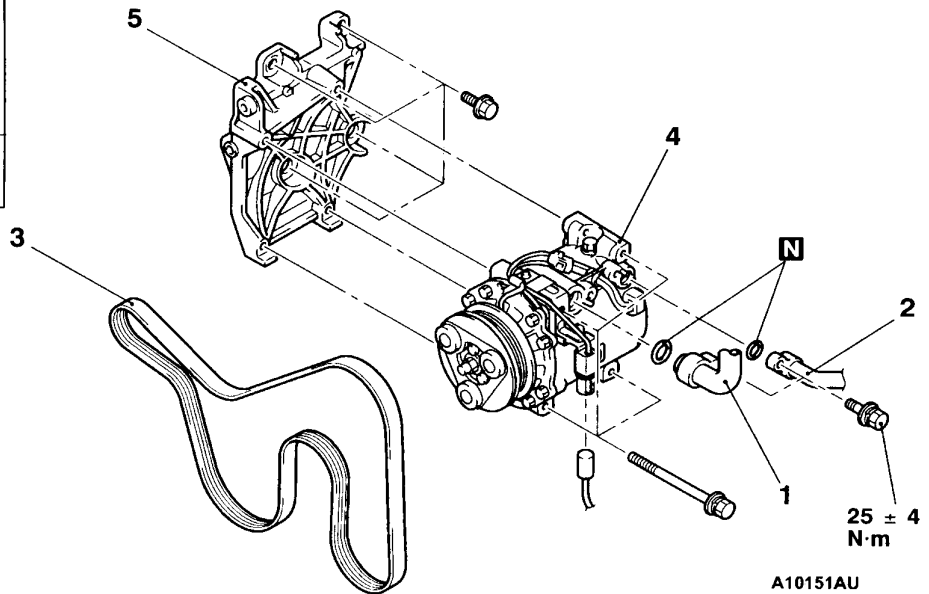
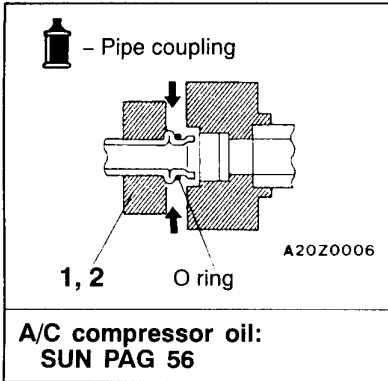

**Removal steps**



- 1. Flexible suction hose connection
- 2. Flexible discharge hose connection
- 3. Drive belt



- 4. Compressor
- 5. Compressor bracket

**REMOVAL SERVICE POINTS**

**◀A▶ DISCONNECTION OF FLEXIBLE SUCTION HOSE AND FLEXIBLE DISCHARGE HOSE**

To prevent the entry of dust or other foreign bodies, plug the dismantled hoses and compressor nipples.

**Caution**

**As the compressor oil and receiver are highly moisture absorbent, use a non-porous material to plug the hose and nipples.**

---

# HOW TO READ THE WIRING DIAGRAMS

## CONTENTS

COMPOSITION AND CONTENTS OF WIRING DIAGRAMS .....	2	MARKING FOR CONNECTOR EARTHING ...	6
HOW TO READ CONFIGURATION DIAGRAMS .....	3	WIRE COLOUR CODES .....	9
HOW TO READ CIRCUIT DIAGRAMS .....	4	ABBREVIATION SYMBOLS .....	10



---

**ABS**

L.H. drive vehicles ..... 198  
R.H. drive vehicles ..... 205

**ACD**

Vehicles without AYC  
<L.H. drive vehicles> ..... 212  
Vehicles without AYC  
<R.H. drive vehicles> ..... 220

**ACD AND AYC**

L.H. drive vehicles ..... 228  
R.H. drive vehicles ..... 238

**SUPPLEMENTAL RESTRAINT SYSTEM  
(SRS) AND SEAT BELT PRETENSIONER**

L.H. drive vehicles ..... 248  
R.H. drive vehicles ..... 250

**IMMOBILIZER SYSTEM**

L.H. drive vehicles ..... 252  
R.H. drive vehicles ..... 254

**INTERCOOLER WATER SPLAY ..... 256**

**SPARE CONNECTOR  
(FOR FRONT FOG LAMP) ..... 258**



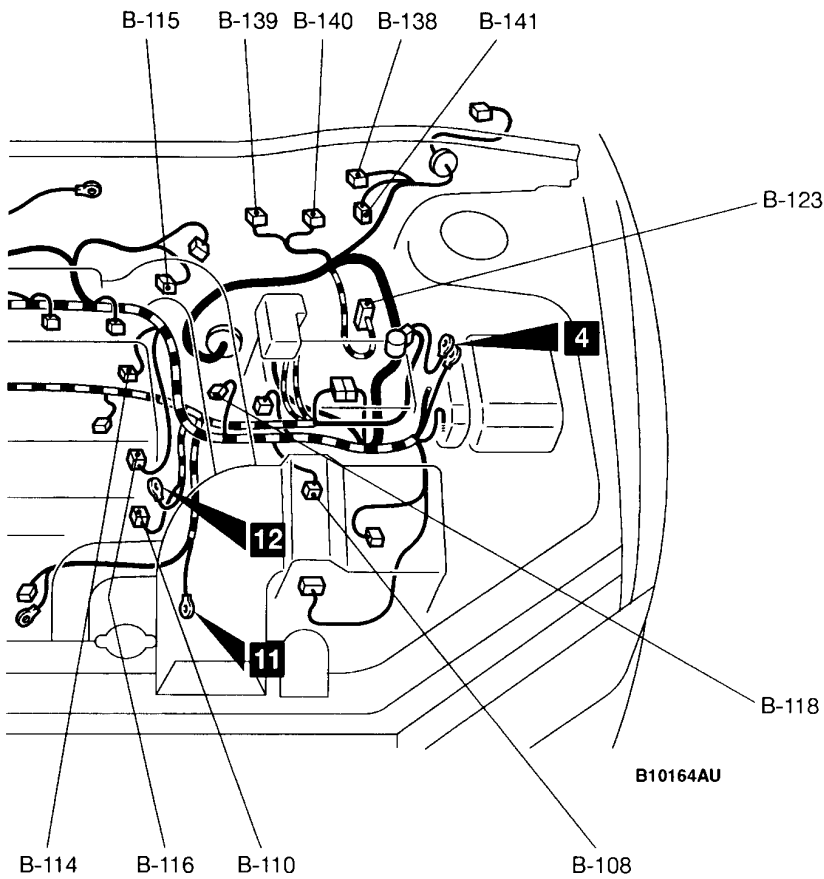

B-121 (3-B) Crank angle sensor  
 B-122 (2-GR) Detonation sensor  
 B-123 (34-B) ABS-ECU  
 B-138 (6-B) Resistor

B-139 (5-B) Electric pump relay <ACD>  
 B-140 (4) Fuel pump relay 3  
 B-141 (2-B) Fuel pump resistor  
 B-142 (2-B) Secondary air control solenoid valve

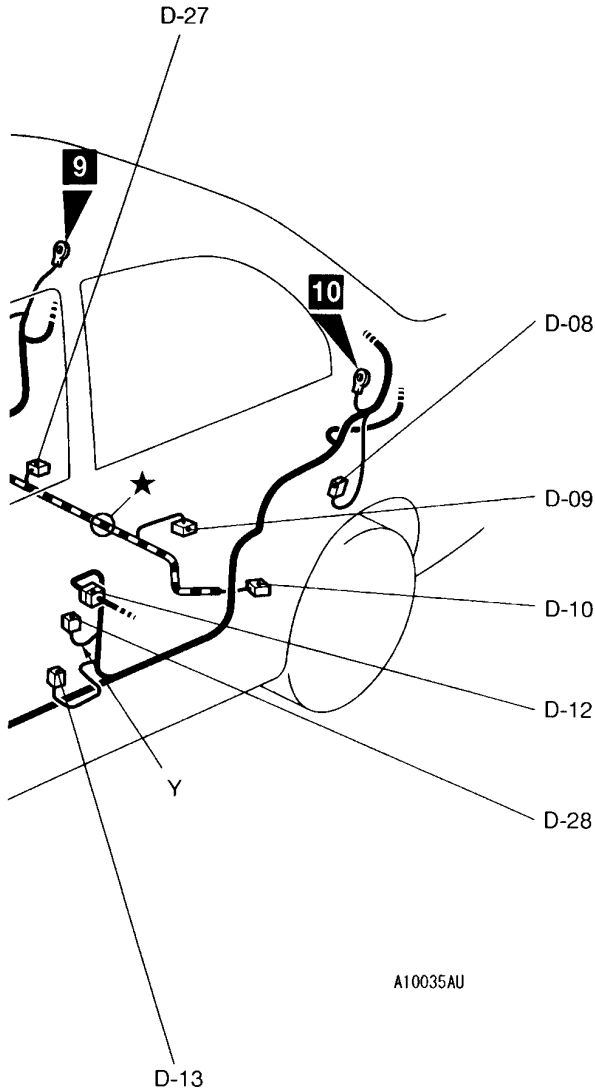

Connector colour code  
 B:Black  
 Y:Yellow  
 L:Blue  
 G:Green  
 R:Red  
 BR:Brown  
 V:Violet  
 O:Orange  
 GR:Gray  
 None: Milk white

- D-18 (1) Cigarette lighter
- D-19 (1-B) Cigarette lighter
- D-20 (2-B) Ashtray illumination lamp
- D-21 (2-B) Cigarette lighter illumination lamp
- D-22 (4) Oxygen sensor (Rear)
- D-23 (1-B) Parking brake switch
- D-26 (2-R) Seat belt pretensioner (RH)
- D-27 (2) Fuel gauge unit (Sub)
- D-28 (2-R) Seat belt pretensioner (LH)

- D-29 (1) Floor wiring harness (RH) and fuel wiring harness combination
- D-30 (8) Floor wiring harness (RH) and fuel wiring harness combination
- D-32 (3-B) G sensor (Longitudinal)
- D-33 (3-B) G sensor (Lateral)
- D-34 (6) Intercooler water spray switch

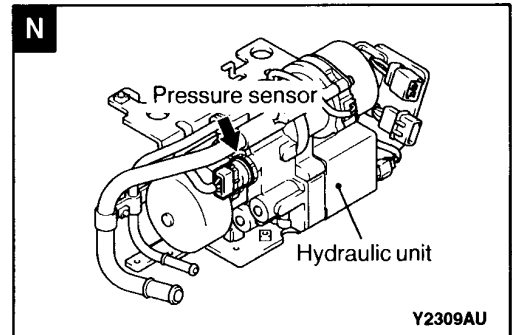
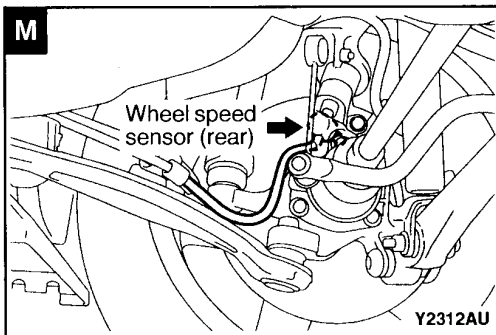
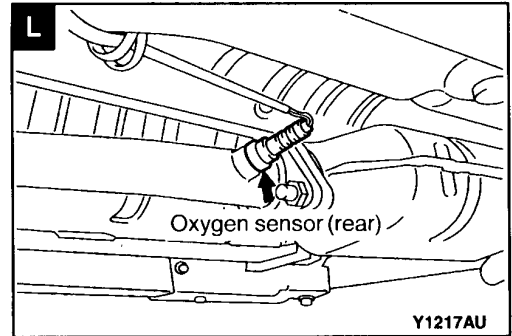
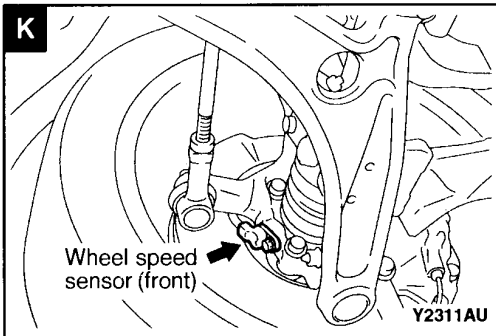
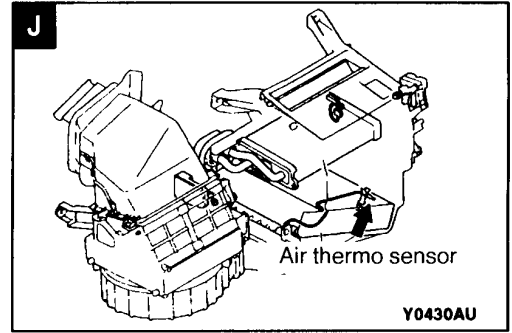
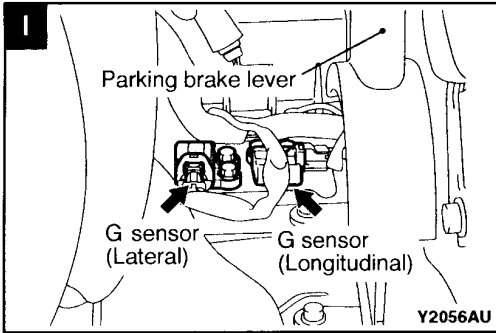
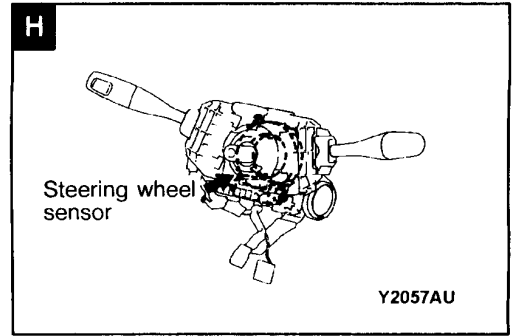
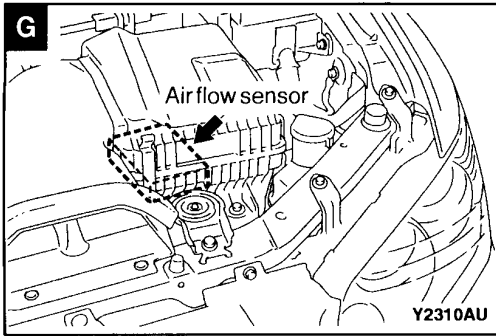
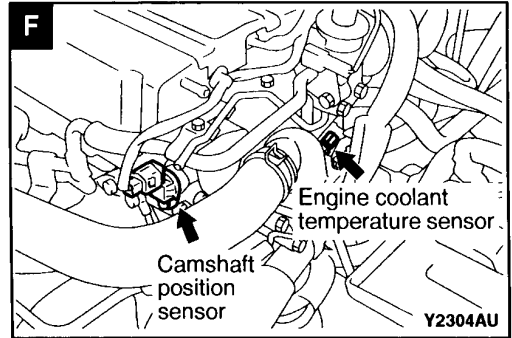
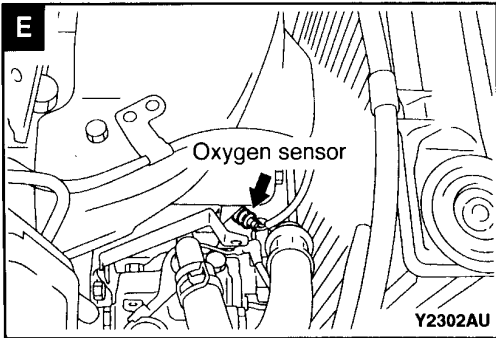

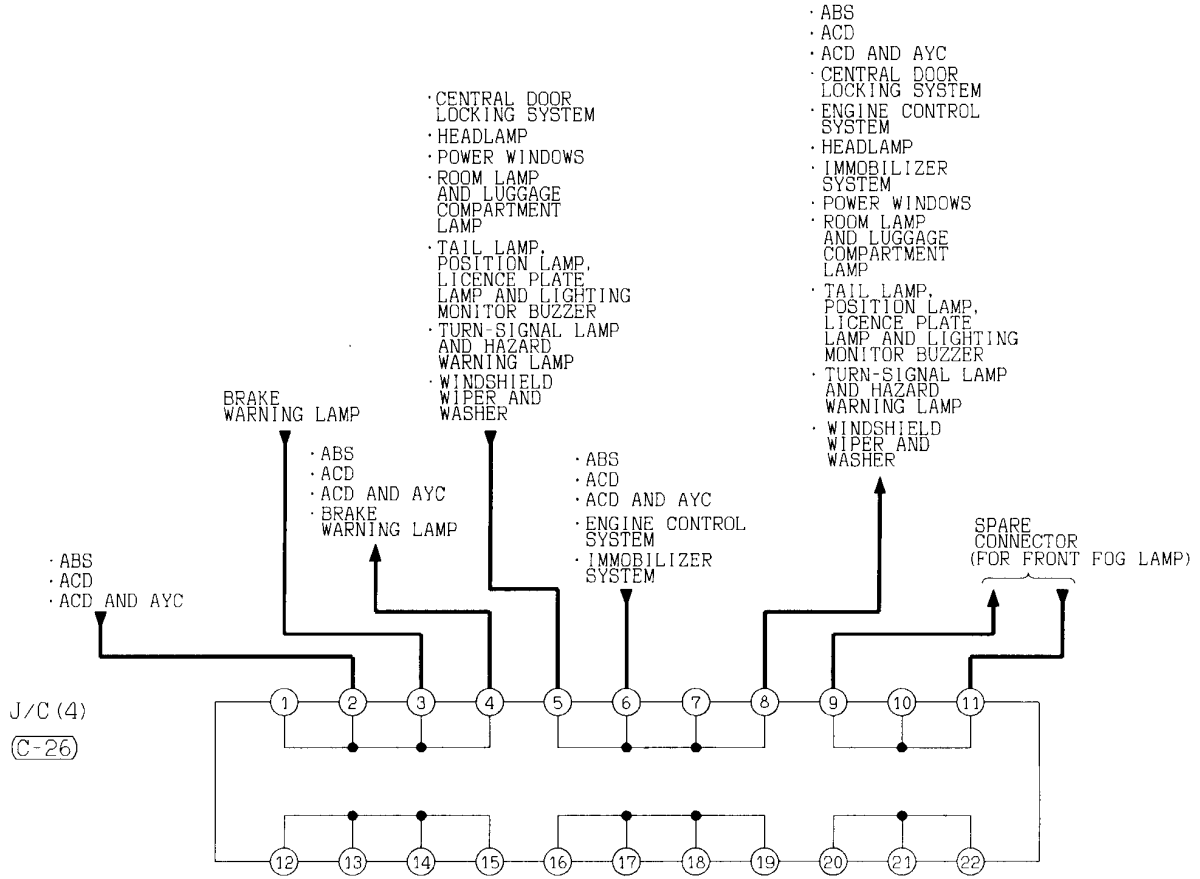

**CENTRALIZED RELAY (relay box in engine compartment)**

Connector No.	Name	Connector No.	Name
A-04X	Spare connector (for front fog lamp relay)	B-05X	Engine speed detection connector
A-05X	Horn relay	B-06X	–
A-06X	Condenser fan relay (LO)	B-07X	–
A-07X	Condenser fan relay (HI)	B-08X	–
A-08X	–	B-09X	Ignition control relay
A-09X	Radiator fan relay	B-10X	–
A-10X	Front-ECU	B-11X	Engine control relay
A-11X	Front-ECU	B-12X	A/C compressor relay

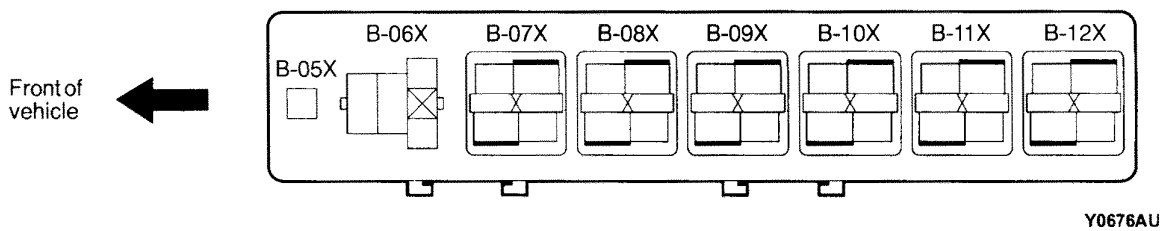
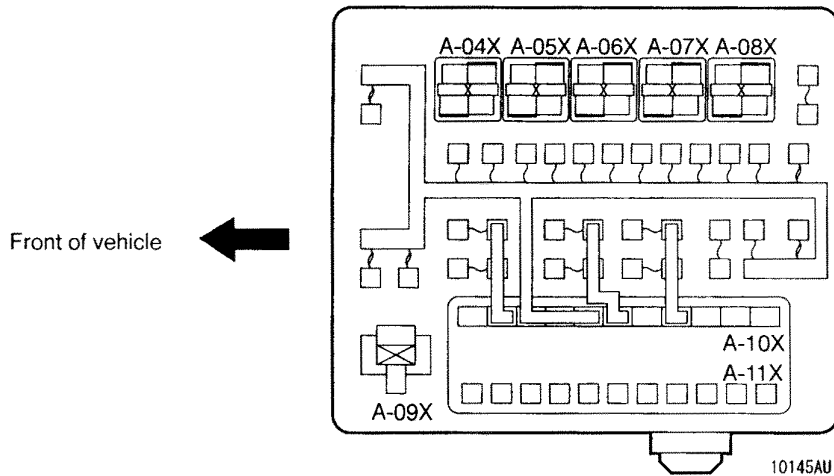

2

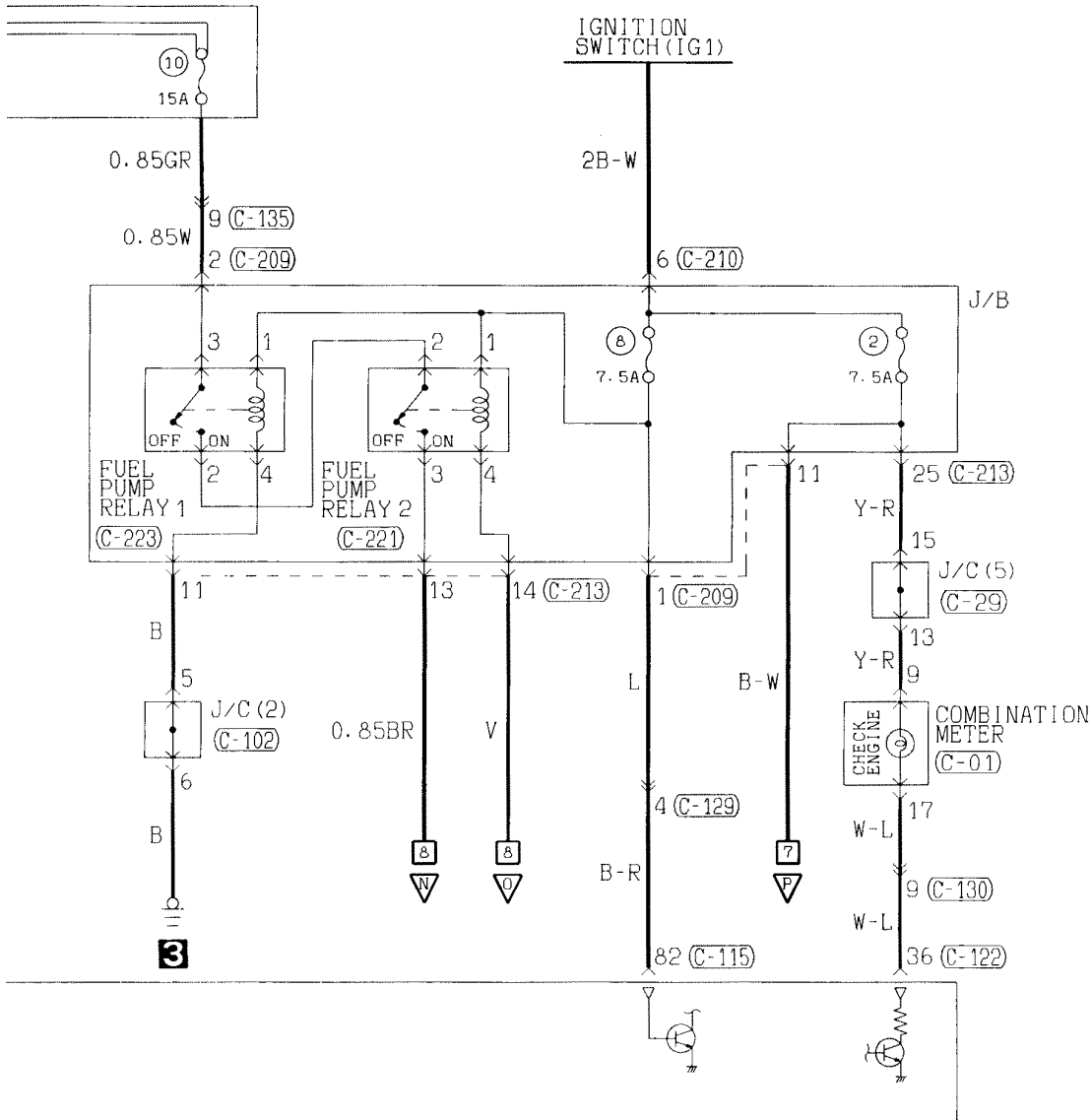

(C-108)

1	2	3	4	5	6	7	8	9	10	11
12	13	14	15	16	17	18	19	20	21	22
23	24	25	26	27	28	29	30	31	32	33

(C-115) (MU801823)

1	2	3	4	5	6	7	8	9	10	11
12	13	14	15	16	17	18	19	20	21	22
23	24	25	26	27	28	29	30	31	32	33

(C-122) (MU801822)

31	32	33	34	35	36	37	38
39	40	41	42	43	44	45	46

(C-126) (MU801824)

1	2	3	4	5	6	7	8	9	10	11	12	13
14	15	16	17	18	19	20	21	22	23	24	25	26

(C-129) MU801867

1	2	3	4		
5	6	7	8	9	10

(C-130)

1	2	3	4	5	6	7	8	9	10	11	12	13
14	15	16	17	18	19	X	20	21	22	23	24	25

Wire colour code  
 B : Black    LG: Light green    G : Green    L : Blue    W : White    Y : Yellow    SB: Sky blue  
 BR: Brown    O : Orange    GR: Gray    R : Red    P : Pink    V : Violet

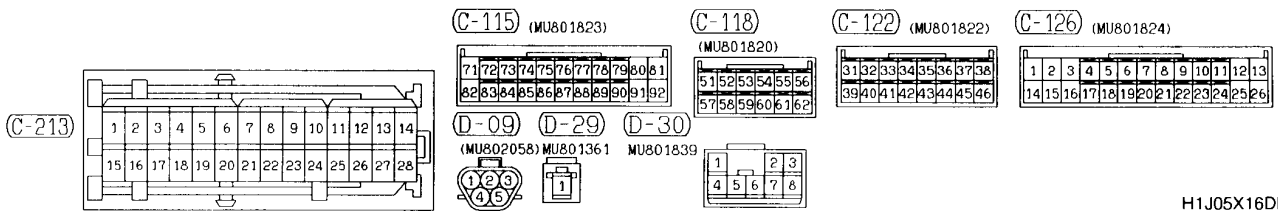
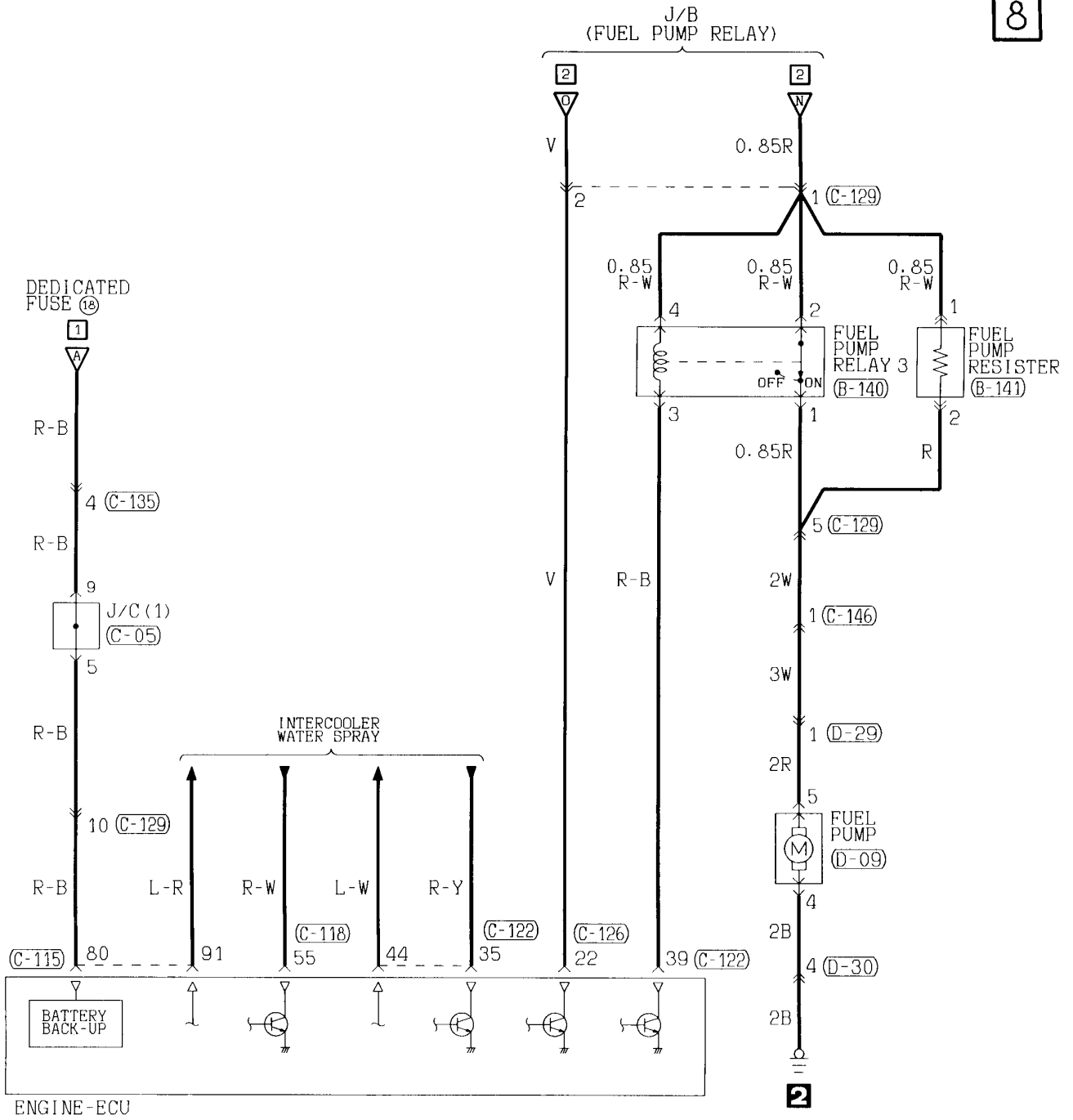

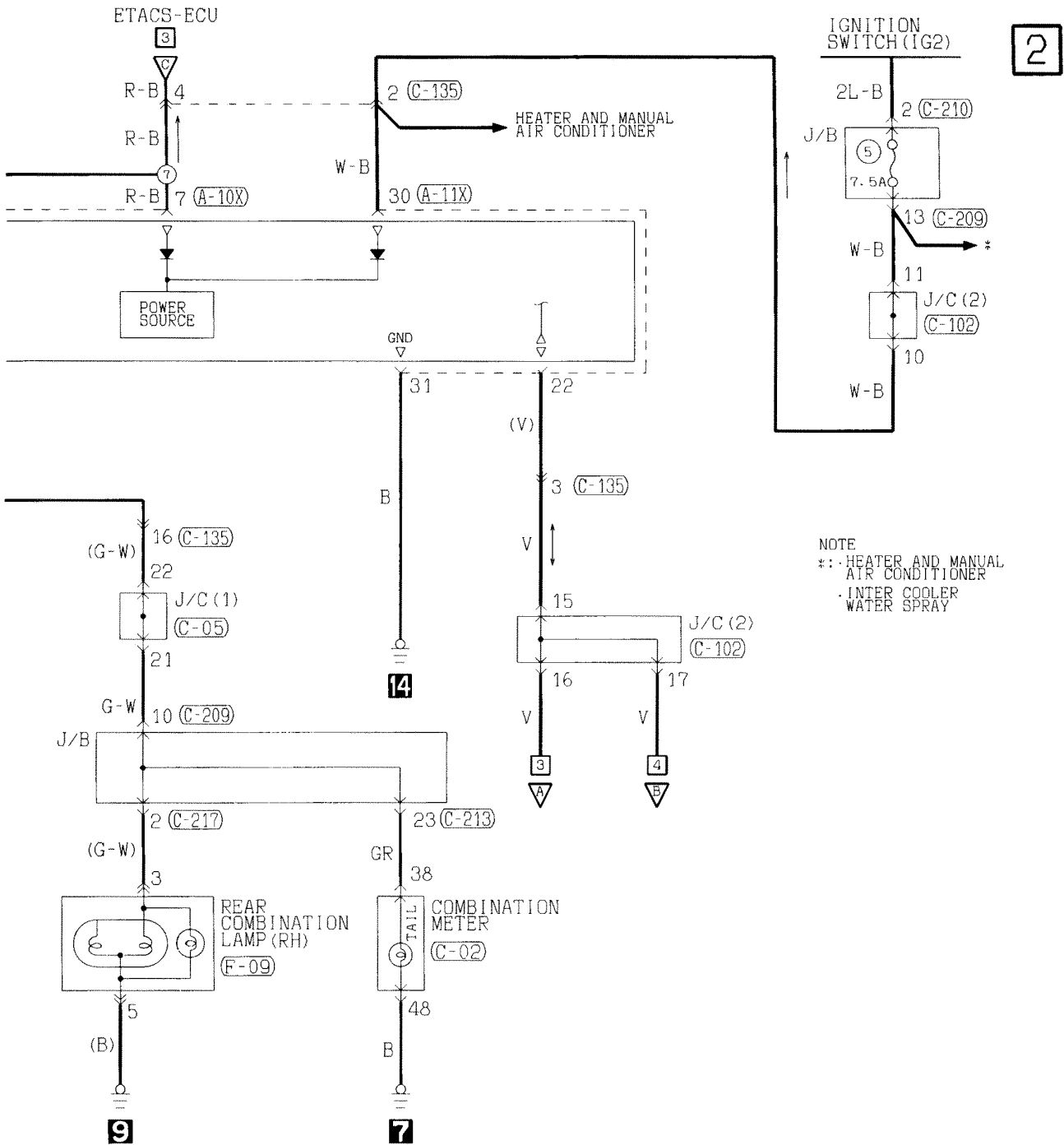

NOTE  
 \*: HEATER AND MANUAL AIR CONDITIONER  
 · INTER COOLER WATER SPRAY

2

14

9

7

(C-05)

(C-102)

(C-133) MU801855

(C-135)

(C-209) MU801857

(C-210) MU801331

1	2	3	4	5	6	7	8	9	10	11
12	13	14	15	16	17	18	19	20	21	22

1	2	3	4	5	6	7	8	9	10	11
12	13	14	15	16	17	18	19	20	21	22

1	2	3	4	5
6	7	8	9	10
11	12	13	14	15

1	2	3	4	5	6	7	8	9	10	11	12	13
14	15	16	17	18	19	20	21	22	23	24	25	

1	2	3	4	5	6
7	8	9	10	11	12
13	14				

1	2
3	4
5	6

Wire colour code

B : Black LG : Light green G : Green L : Blue W : White Y : Yellow SB : Sky blue  
 BR : Brown O : Orange GR : Gray R : Red P : Pink V : Violet

3

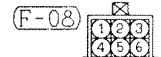
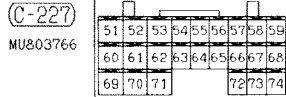
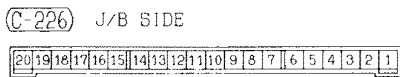
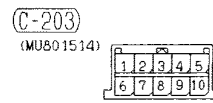
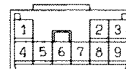
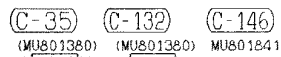
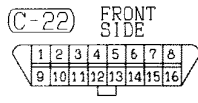
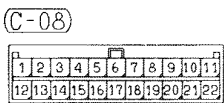
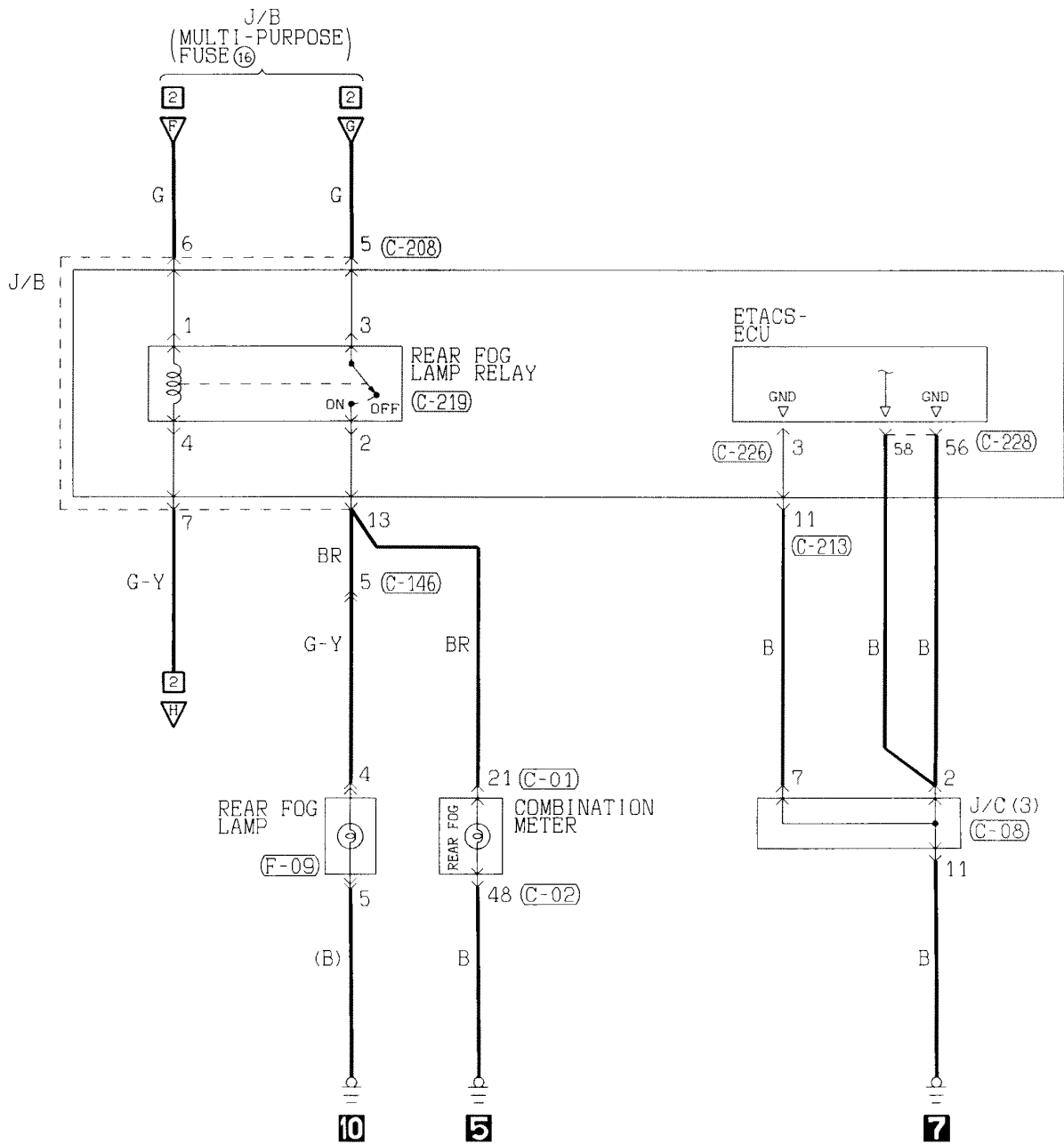

H1J08X29BB

BACK-UP LAMP

R.H. drive vehicles

1

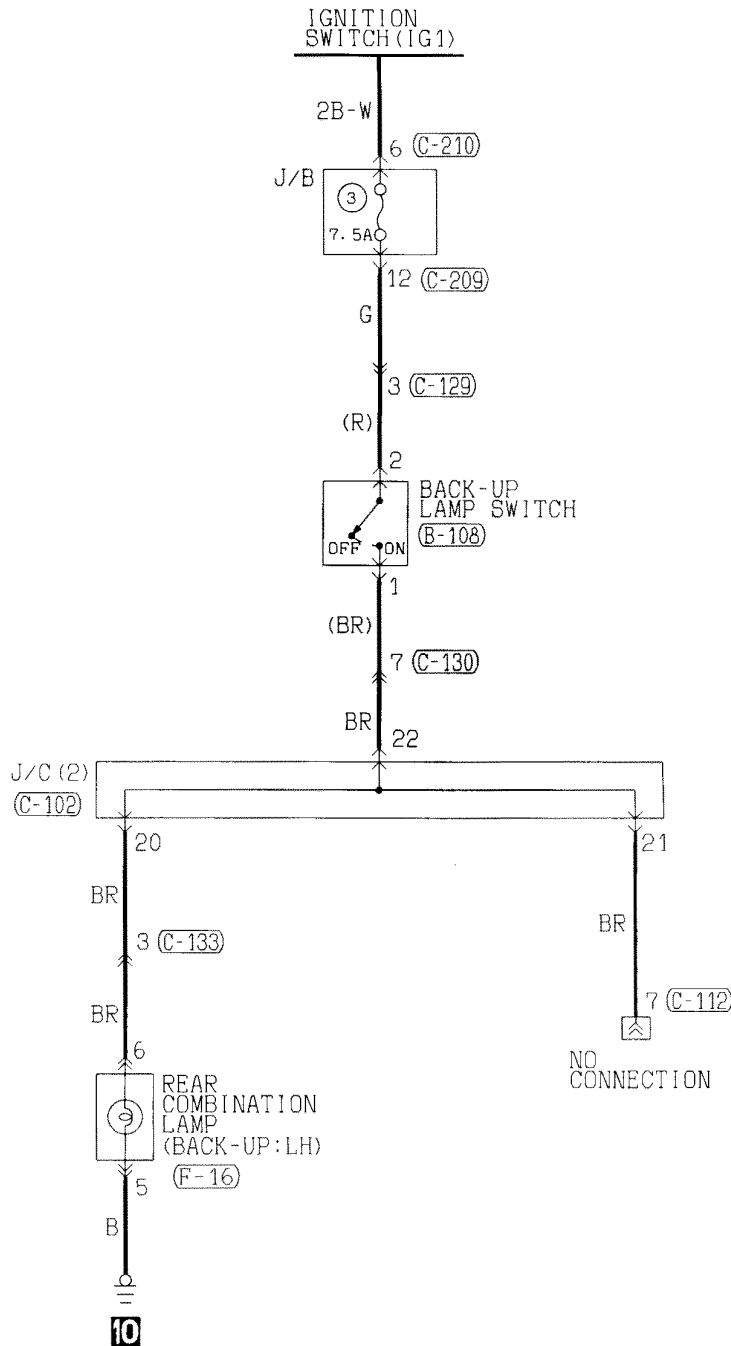

<b>(B-108)</b> MU802601 ①②	<b>(C-102)</b> MU801857 1 2 3 4 5 6 7 8 9 10 11 12 13 14 15 16 17 18 19 20 21 22	<b>(C-112)</b> MU801855 1 2 3 4 5 6 7 8 9 10 11 12 13	<b>(C-129)</b> (MU801845) 1 2 3 4 5 6 7 8 9 10	<b>(C-130)</b> MU801855 1 2 3 4 5 6 7 8 9 10 11 12 13 14 15 16 17 18 19 20 21 22 23 24 25	<b>(C-133)</b> MU801855 1 2 3 4 5 6 7 8 9 10 11 12 13
<b>(C-209)</b> MU801857 1 2 3 4 5 6 7 8 9 10 11 12 13 14	<b>(C-210)</b> MU801331 1 2 3 4 5 6	<b>(F-16)</b> ①②③ ④⑤⑥	Wire colour code B : Black    LG : Light green    G : Green    L : Blue BR : Brown    O : Orange    GR : Gray    R : Red W : White    SB : Sky blue    P : Pink    Y : Yellow V : Violet		

**OIL PRESSURE WARNING LAMP  
BRAKE WARNING LAMP**

2

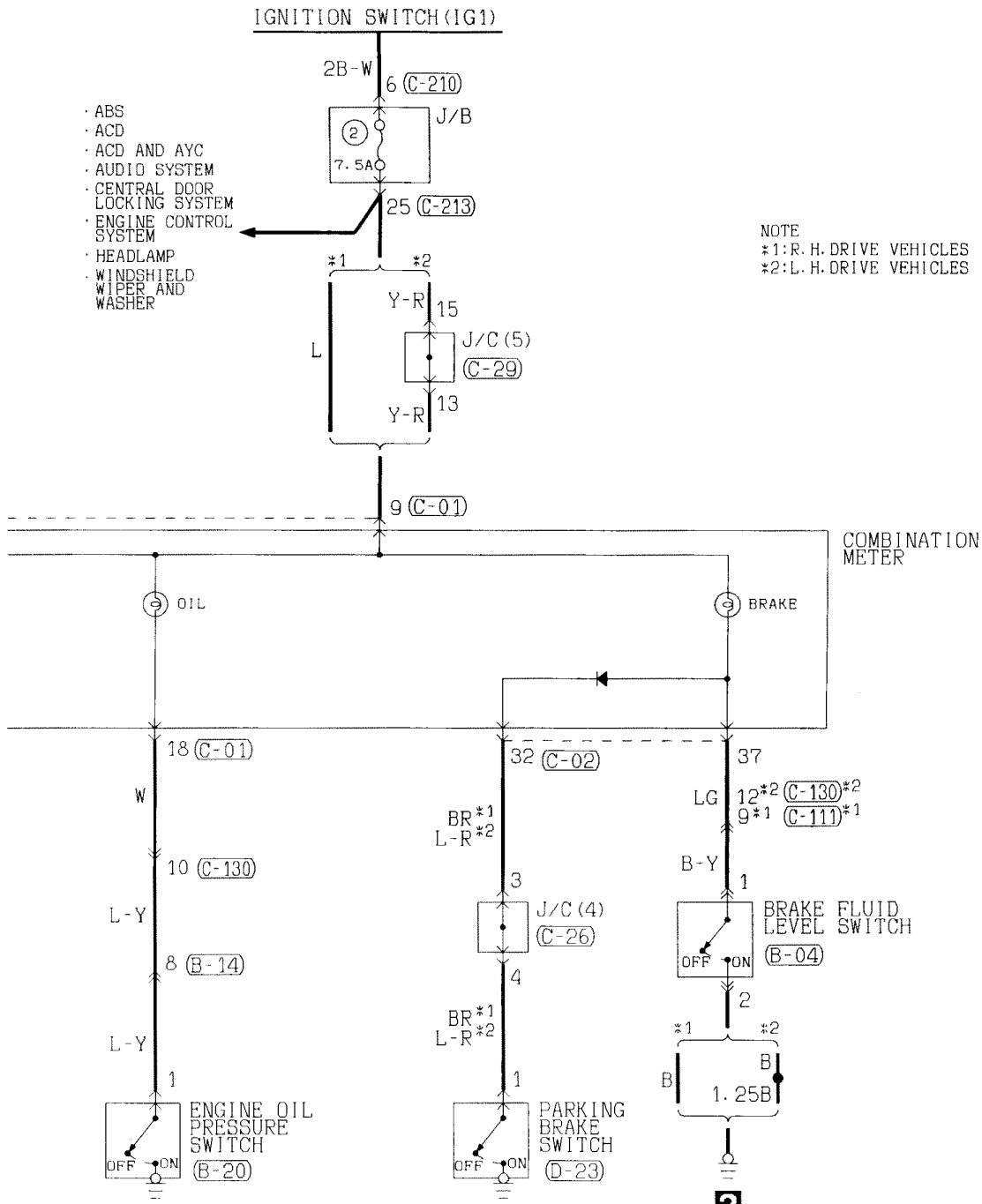

(C-05)

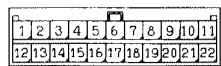

(C-26)

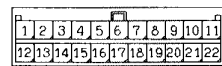

(C-29)

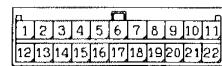

(C-111)

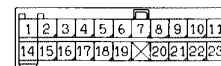

(C-130)

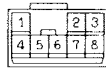
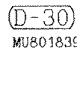
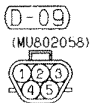
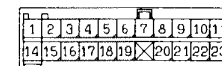

Wire colour code  
 B : Black  
 BR : Brown  
 W : White  
 V : Violet

LG : Light green  
 O : Orange  
 SB : Sky blue

G : Green  
 GR : Gray  
 P : Pink

L : Blue  
 R : Red  
 Y : Yellow

2

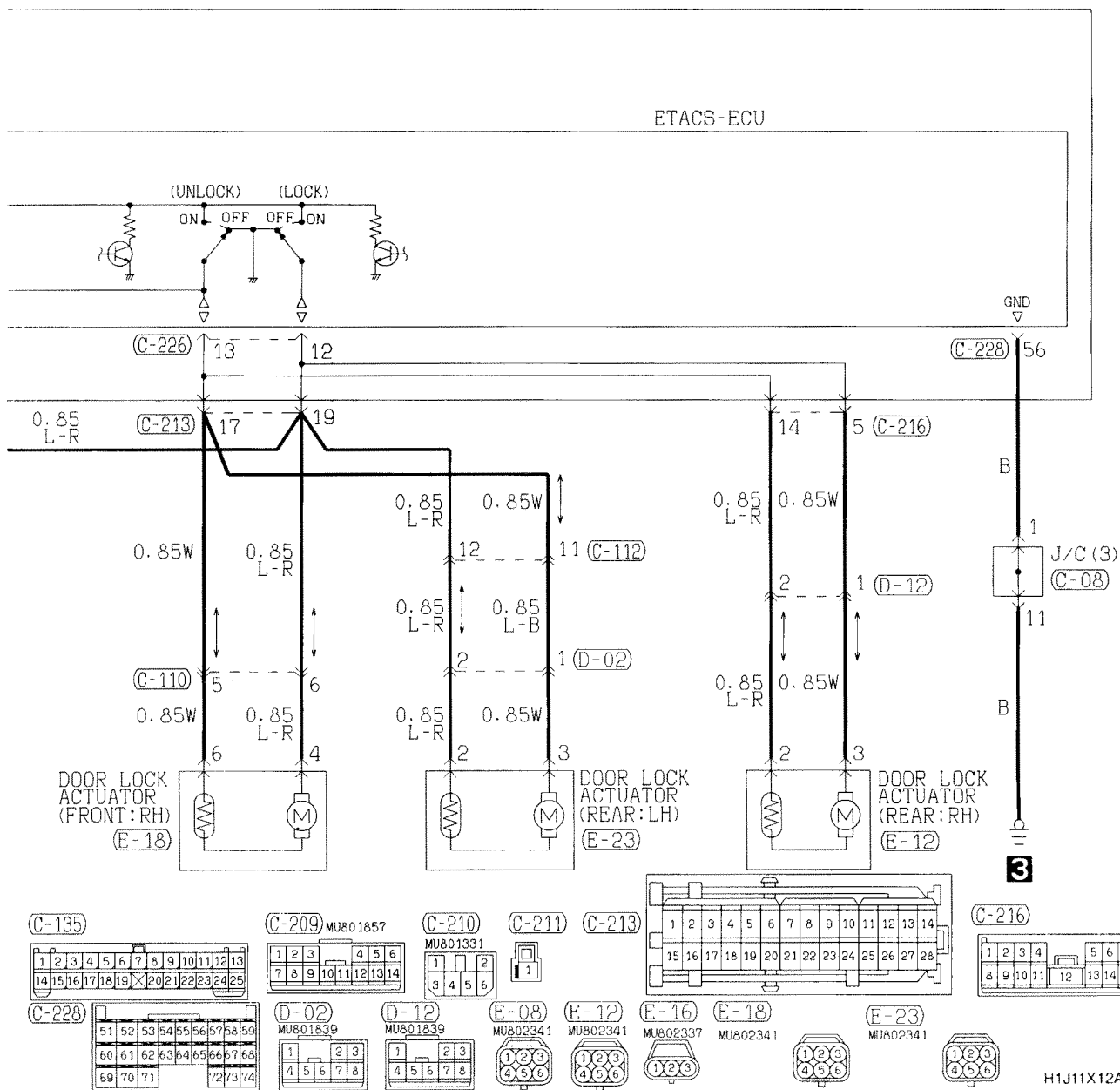

DEFOGGER

1

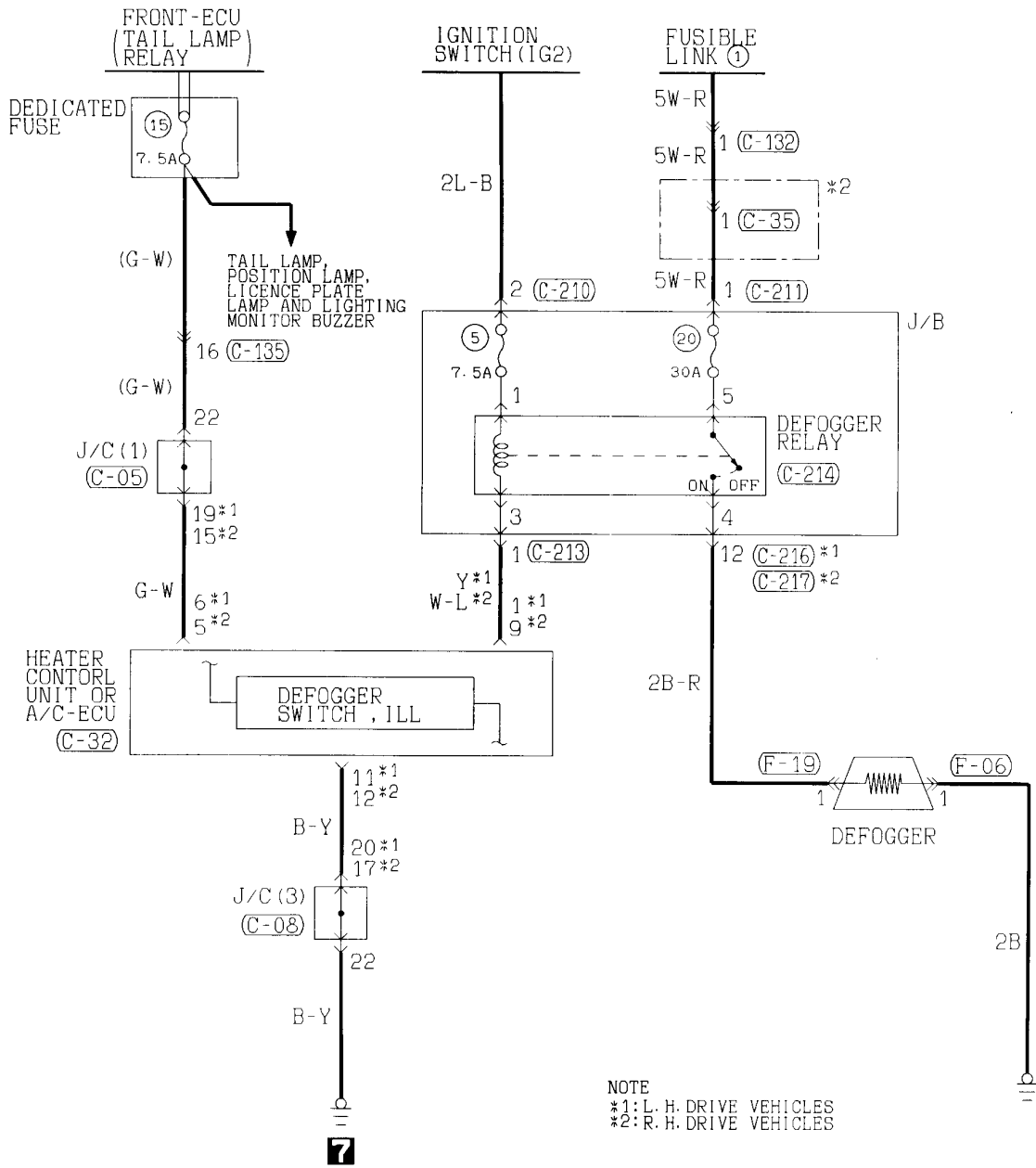

7

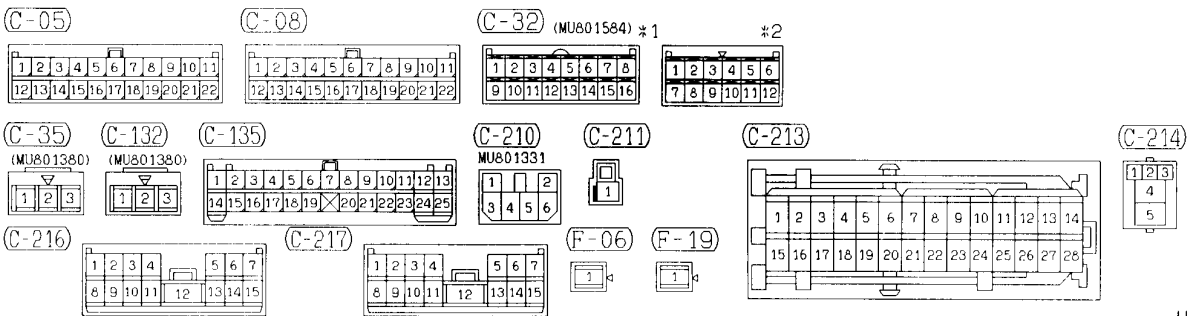

2

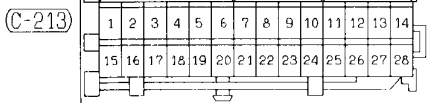
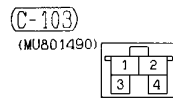
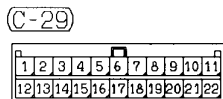
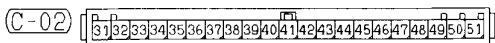
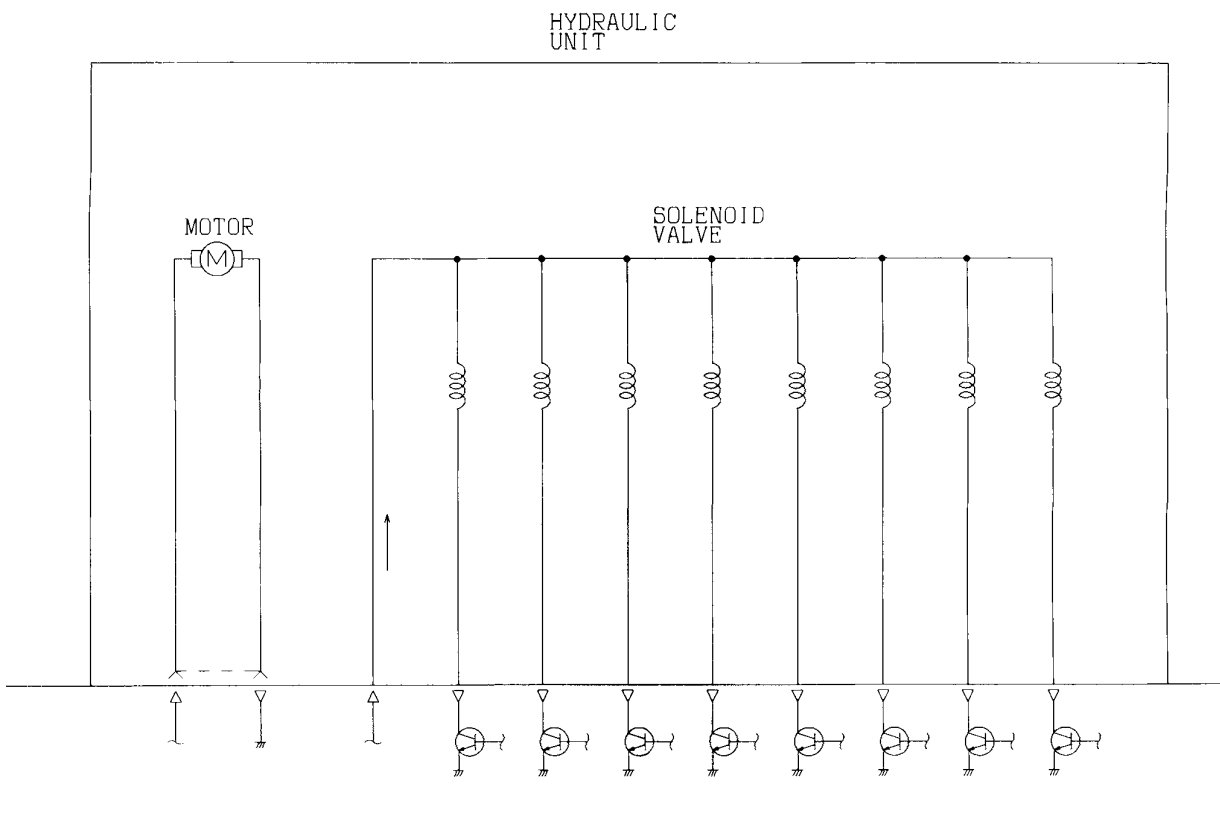

Wire colour code

B : Black	LG : Light green	G : Green	L : Blue
BR : Brown	O : Orange	GR : Gray	R : Red
W : White	SB : Sky blue	P : Pink	Y : Yellow
V : Violet			

2

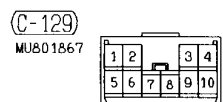
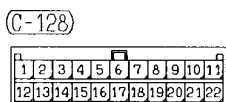
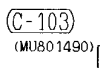
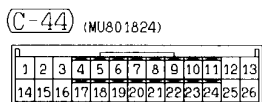
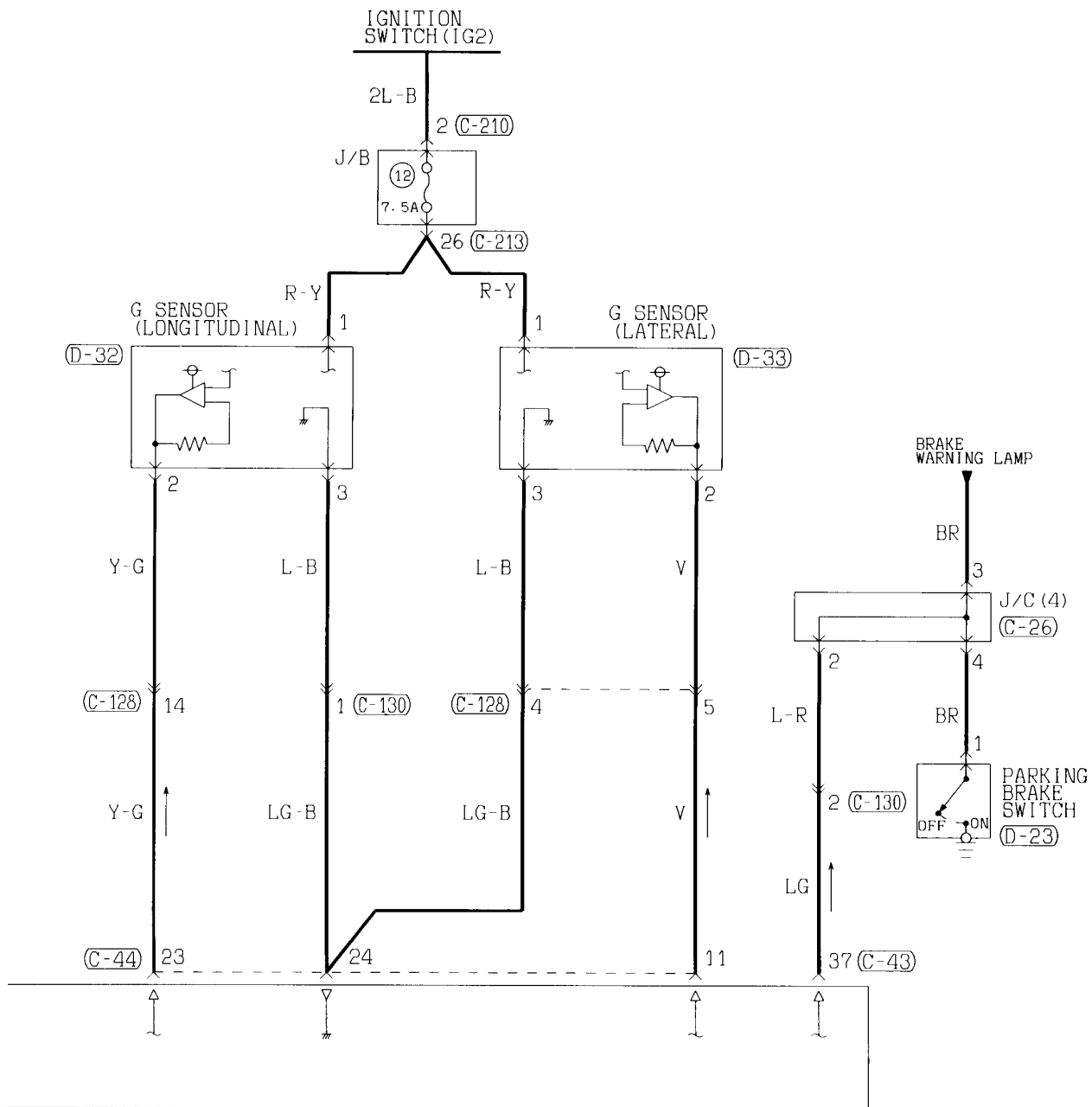

Wire colour code  
 B : Black    LG : Light green    G : Green    L : Blue  
 BR : Brown    O : Orange    GR : Gray    R : Red  
 W : White    SB : Sky blue    P : Pink    Y : Yellow  
 V : Violet

8

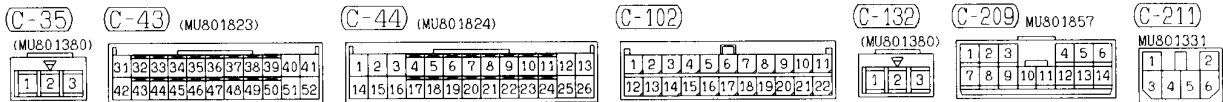
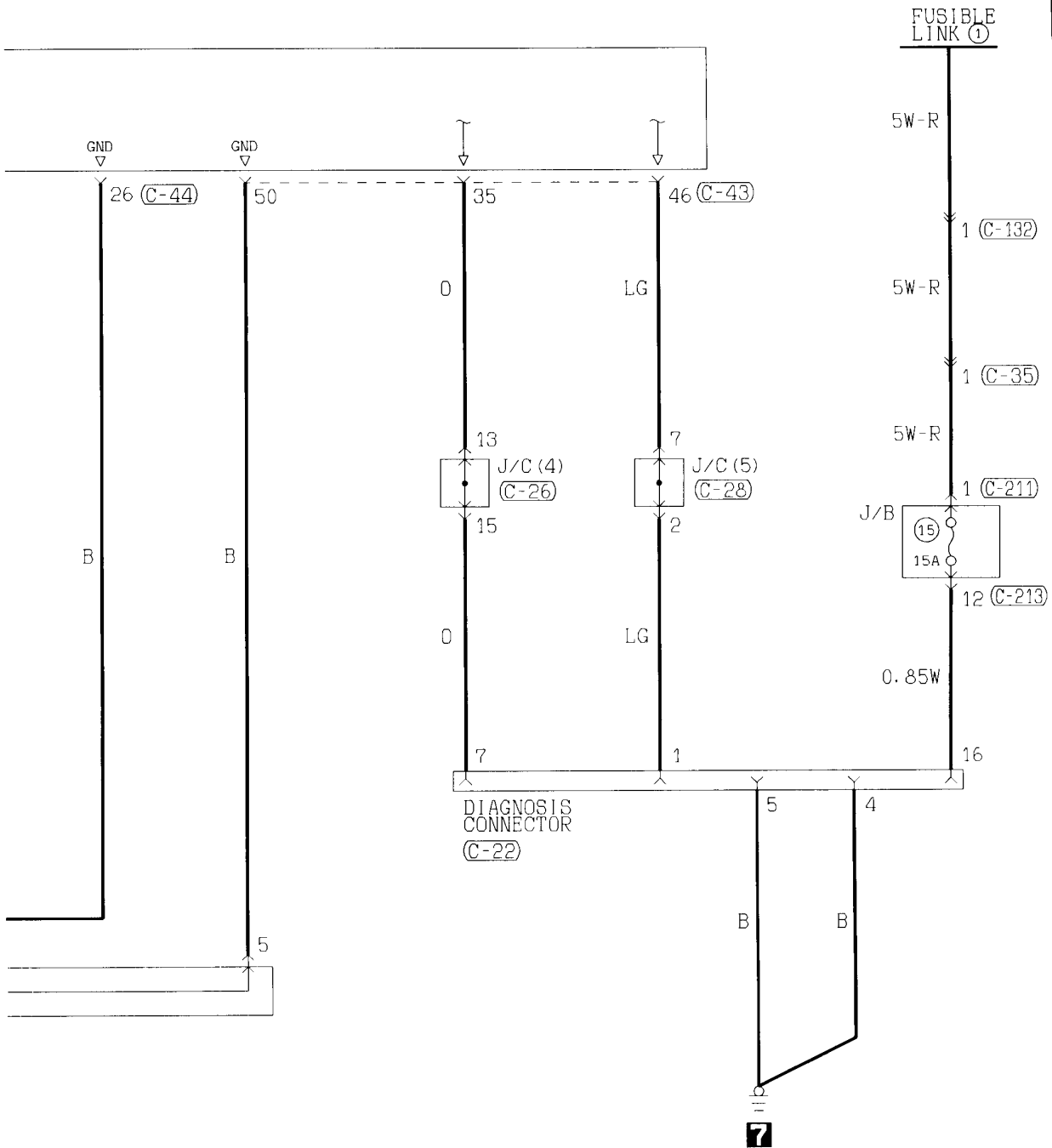

Wire colour code  
 B : Black    LG: Light green    G : Green    L : Blue    W : White    Y : Yellow    SB: Sky blue  
 BR: Brown    O : Orange    GR: Gray    R : Red    P : Pink    V : Violet



2

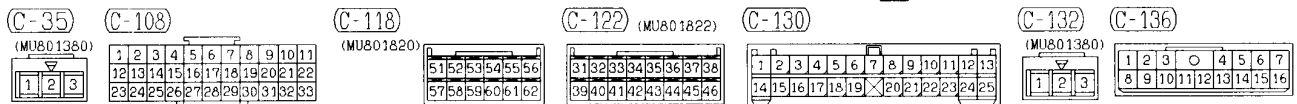
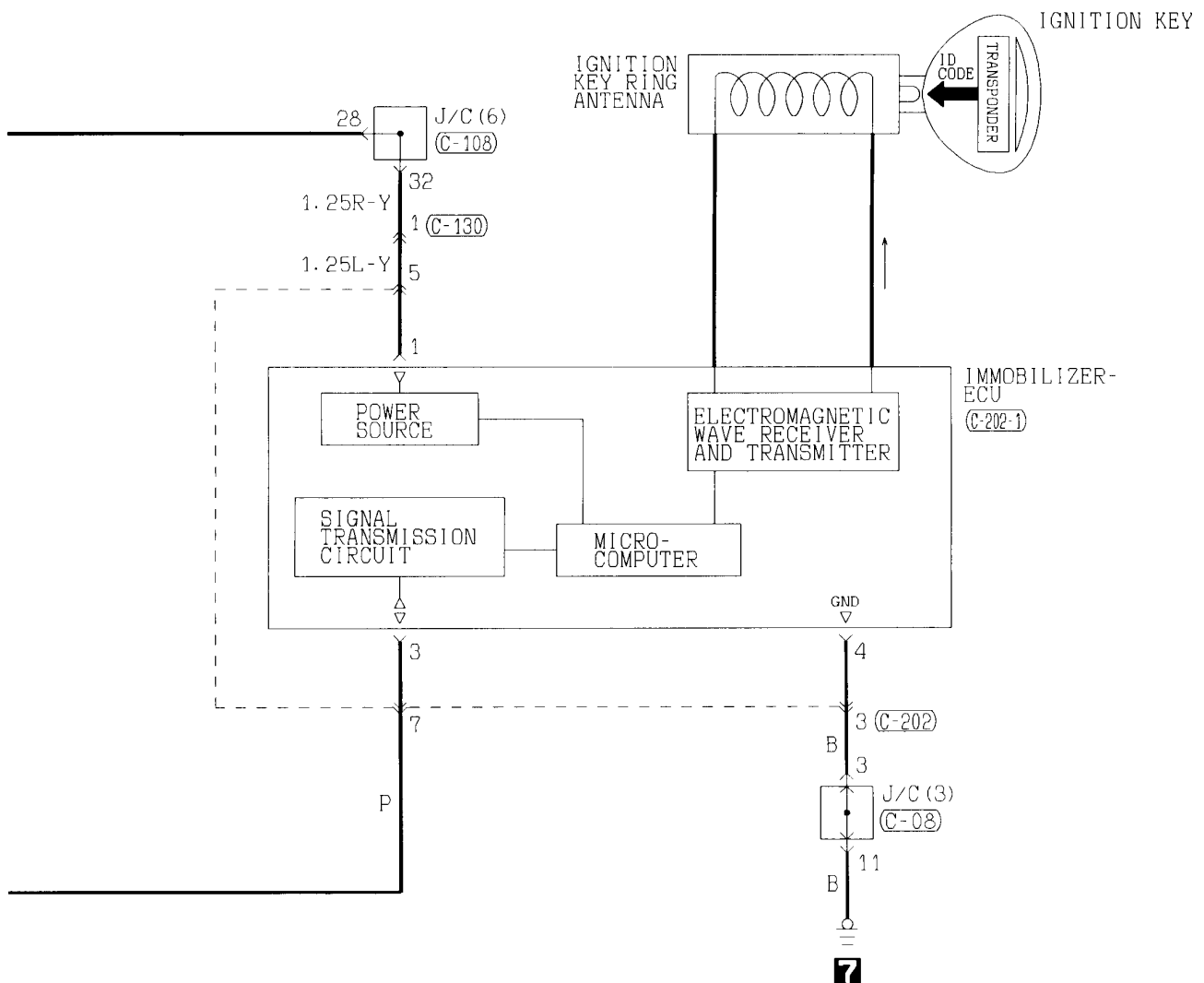

Wire colour code  
 B : Black    LG : Light green    G : Green    L : Blue    W : White    Y : Yellow    SB : Sky blue  
 BR : Brown    O : Orange    GR : Gray    R : Red    P : Pink    V : Violet

**INDEX****In order of parts name**

	Parts name	Connector No.	Circuit diagram page	Wiring diagram page
	4WD-ECU <ACD>	C-43	B-201,209,212,213,214,215,216,218,219,220,221,222,223,224,226,227,228,230,231,232,234,236,237,238,240,241,242,244,246,247	B-19,25
	4WD-ECU <ACD>	C-44	B-201,209,212,213,216,217,219,220,221,224,225,227,228,229,232,234,235,237,238,239,242,244,245,247	B-19,25
A	A/C compressor	A-47	B-178,184	B-7,9
	A/C compressor relay	B-12X	B-73,178,184	B-10,14
	A/C-ECU or heater control unit	C-32	B-175,181,185	B-19,25
	ABS-ECU	B-123	B-198,200,201,202,203,204,205,206,208,209,210,211,229,232,233,239,242,243	B-13,17
	ACD mode changeover switch	C-142	B-214,222,230,240	B-21,27
	Air bag module (squib) <Driver's side>	C-207	B-248,250	B-22,28
	Air bag module (squib) <Passenger's side>	C-109	B-249,251	B-20,26
	Air flow sensor	B-31	B-90,98	B-11,15
	Alternator	B-21	B-84	B-11,15
	Alternator	B-22	B-84	B-11,15
	Ashtray illumination lamp	D-20	B-195	B-31,33
B	Back-up lamp switch	B-108	B-142,143	B-12,16
	Blower motor	C-14	B-174,180	B-18,24
	Blower relay	C-215	B-54,55,174,180	B-23,29
	Blower switch	C-131	B-174,180	B-21,27
	Brake fluid level switch	B-04	B-157	B-10,14
C	Camshaft position sensor	B-116	B-88,96	B-12,16
	Cigarette lighter	D-18	B-195	B-31,33
	Cigarette lighter	D-19	B-195	B-31,33
	Cigarette lighter illumination lamp	D-21	B-195	B-31,33
	Clock	C-04	B-194	B-18,24
	Clock spring <SRS>	C-204	B-248,250	B-22,28
	Clock spring <SRS>	C-205	B-146	B-22,28

BODY MAIN CROSS-SECTIONAL VIEWS

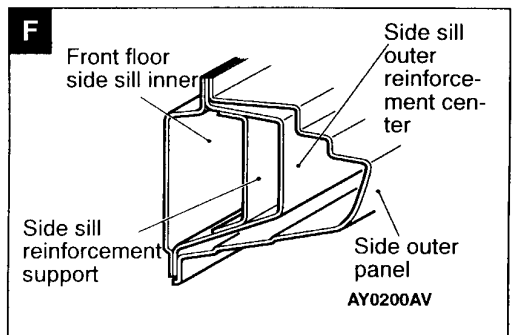
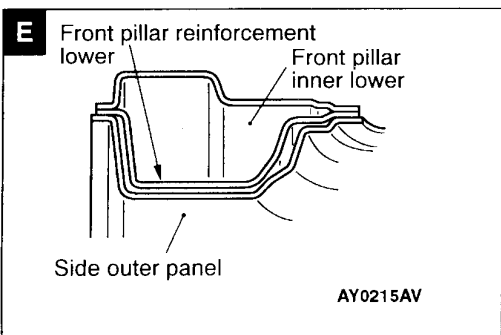
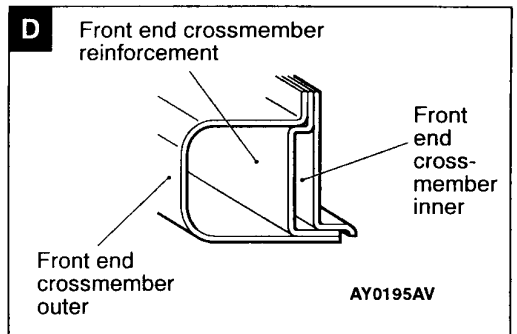
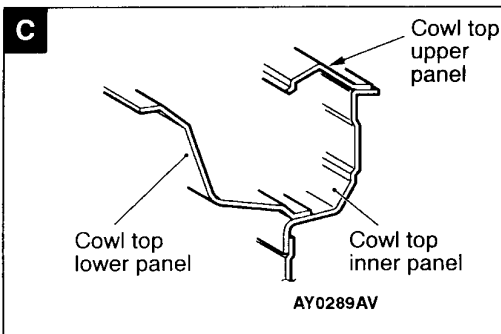
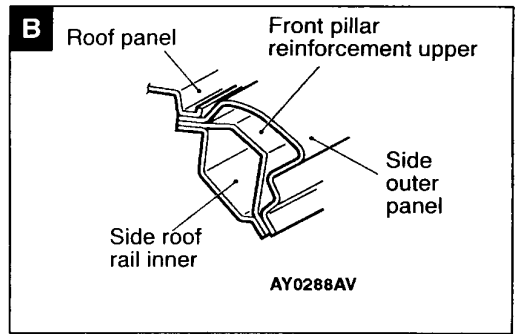
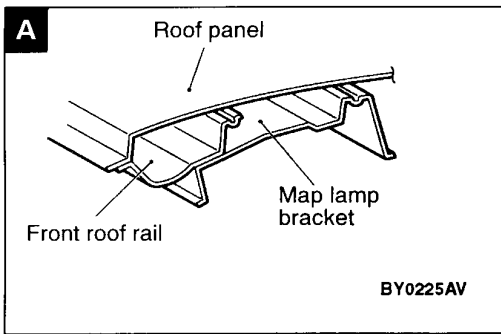
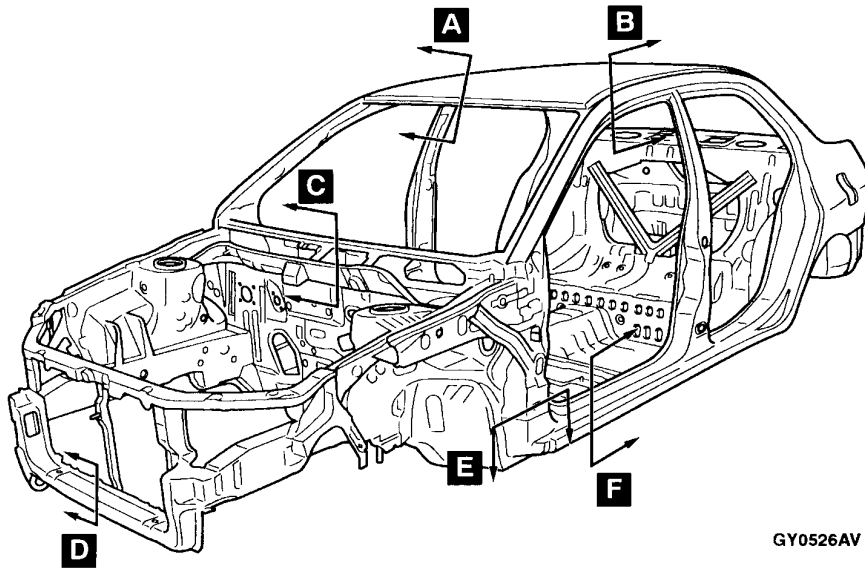

## Rear Floor

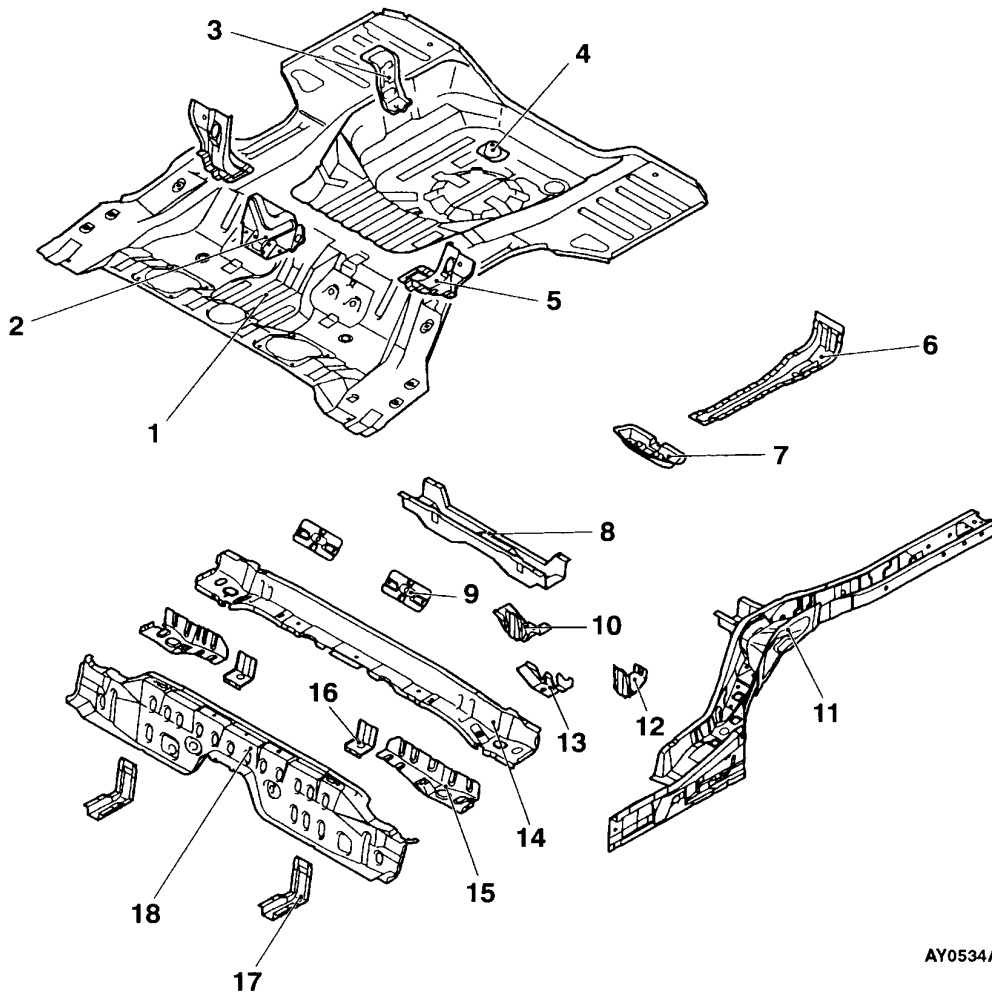

AY0534AV

- |   |  |
|---|--|
| 1. Rear floor pan   | 11. Rear floor sidemember  |
| 2. Seat back plate extension  | 12. Fuel tank rear bracket (Vehicles with AYC)                             |
| 3. Jack bracket   | 13. Differential/fuel support bracket front (Vehicles with mechanical LSD) |
| 4. Spare tire bracket   | 14. Rear seat crossmember  |
| 5. Rear seat back reinforcement   | 15. Seat crossmember reinforcement   |
| 6. Towing hook reinforcement  | 16. Fuel tank front reinforcement  |
| 7. Crossmember center support   | 17. Front floor sidemember extension                                       |
| 8. Rear floor crossmember   | 18. Rear floor extension   |
| 9. Rear floor seatbelt reinforcement                                      |  |
| 10. Differential/fuel support bracket rear (Vehicles with mechanical LSD) |  |

CLICK HERE TO **DOWNLOAD** THE COMPLETE MANUAL

- Thank you very much for reading the preview of the manual.
- You can download the complete manual from: [www.heydownloads.com](http://www.heydownloads.com) by clicking the link below



- Please note: If there is no response to CLICKING the link, please download this PDF first and then click on it.

CLICK HERE TO **DOWNLOAD** THE COMPLETE MANUAL