



Service Manual

Chassis & Mast

FC/LC

FD100NM1	F15E-90011-99999
FD100NM1S	F15E-90011-99999
FD120NM1	F15E-90011-99999
FD120NM1S	F15E-90011-99999
FD135NM1	F15E-90011-99999
FD135NM1S	F15E-90011-99999
FD150ANM1	F24C-20011-39999
FD150ANM1S	F24C-20011-39999

CLICK HERE TO **DOWNLOAD** THE COMPLETE MANUAL

- Thank you very much for reading the preview of the manual.
- You can download the complete manual from: www.heydownloads.com by clicking the link below



- Please note: If there is no response to CLICKING the link, please download this PDF first and then click on it.

CLICK HERE TO **DOWNLOAD** THE COMPLETE MANUAL

Chapter 9 BRAKE SYSTEM

1.	Specifications	9-1
1.1	Dry Brake System	9-1
2.	Structure	9-2
2.1	Outline of Wheel Brake System	9-2
2.2	Air Governor	9-3
2.3	Air Dryer	9-4
2.4	Relay Valve	9-7
2.5	Brake Control Valve	9-9
2.6	Air Master	9-10
2.7	Wheel Brake	9-13
2.8	Parking Brake System	9-14
2.9	Parking Brake Lever	9-15
2.10	Parking Brake	9-16
3.	Removing Wheel Brake	9-17
3.1	Preparation	9-17
3.2	Removal Sequence	9-17
3.3	Suggestions for Removal	9-18
4.	Installing Wheel Brake	9-20
4.1	Suggestions for Installation	9-20
5.	Disassembling Wheel Brake	9-21
5.1	Disassembly Sequence	9-21
5.2	Suggestions for Disassembly	9-22
6.	Inspecting and Repairing Wheel Brake	9-23
7.	Assembling Wheel Brake	9-24
7.1	Assembly Sequence	9-24
7.2	Suggestions for Assembly	9-25
8.	Disassembling Wheel Cylinder	9-27
8.1	Disassembly Sequence	9-27
9.	Inspecting and Repairing Wheel Cylinder	9-28
10.	Disassembling Air Governor	9-29
10.1	Disassembly Sequence	9-29
11.	Assembling Air Governor	9-29
12.	Assembling Wheel Cylinder	9-29
12.1	Suggestions for Assembly	9-29
13.	Disassembling Air Master	9-30
13.1	Disassembly Sequence	9-30
13.2	Suggestions for Disassembly	9-30
14.	Assembling Air Master	9-31
14.1	Suggestions for Assembly	9-31
15.	Disassembling Parking Brake	9-32
15.1	Disassembly Sequence	9-32
16.	Inspecting and Repairing Parking Brake	9-33
17.	Assembling Parking Brake	9-33
17.1	Suggestions for Assembly	9-33

3. Removing Radiator and Intercooler

3.1 Preparation

Drain the coolant from the radiator by loosening the drain cock.

⚠ WARNING

Check the cooling water temperature is lowered enough before opening the drain cock.

3.2 Removal Sequence of Radiator and Intercooler

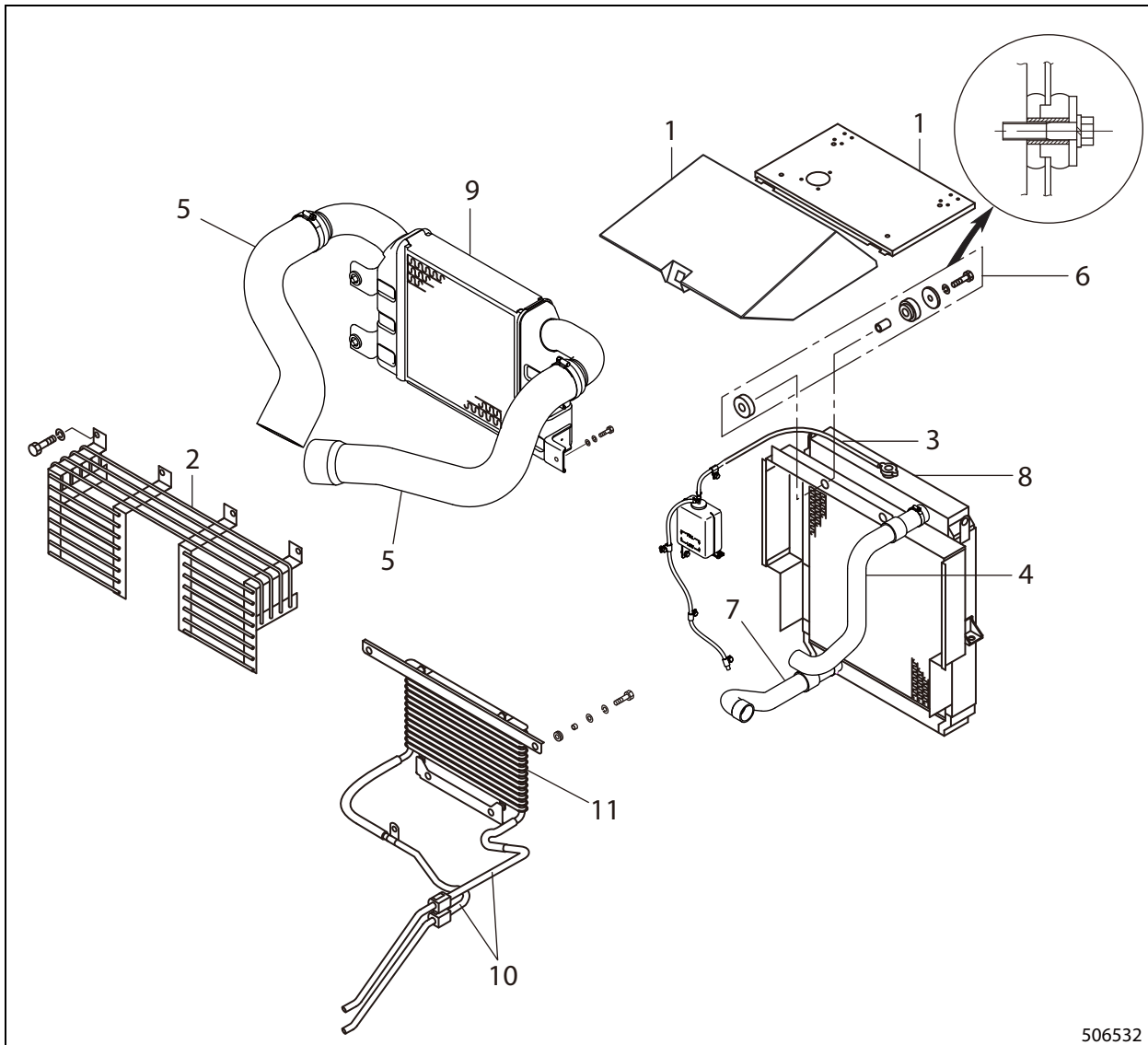

506532

- | | |
|----------------------------------|---------------------|
| 1. Engine cover, Radiator cover | 7. Radiator hose |
| 2. Fan guard | 8. Radiator |
| 3. Reserve tank hose | 9. Intercooler |
| 4. Radiator hose | 10. Oil cooler pipe |
| 5. Intercooler hose | 11. Oil cooler |
| 6. Grommet, Spacer, Washer, Bolt | |

Control valve (FC)

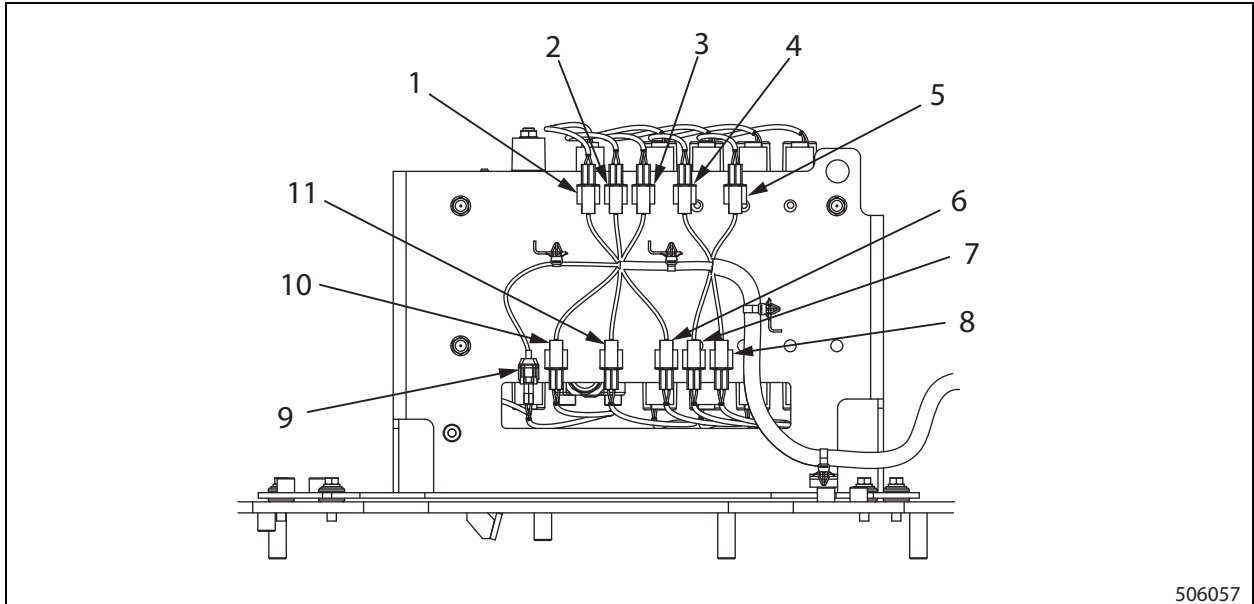

506057

- | | |
|--------------------|--------------------|
| 1. Lift (Up) | 6. Attachment 1B |
| 2. Tilt (Backward) | 7. Attachment 2B |
| 3. Attachment 1A | 8. Attachment 3B |
| 4. Attachment 2A | 9. Unloader valve |
| 5. Attachment 3A | 10. Lift (Down) |
| | 11. Tilt (Forward) |

Fuse box, Relay box

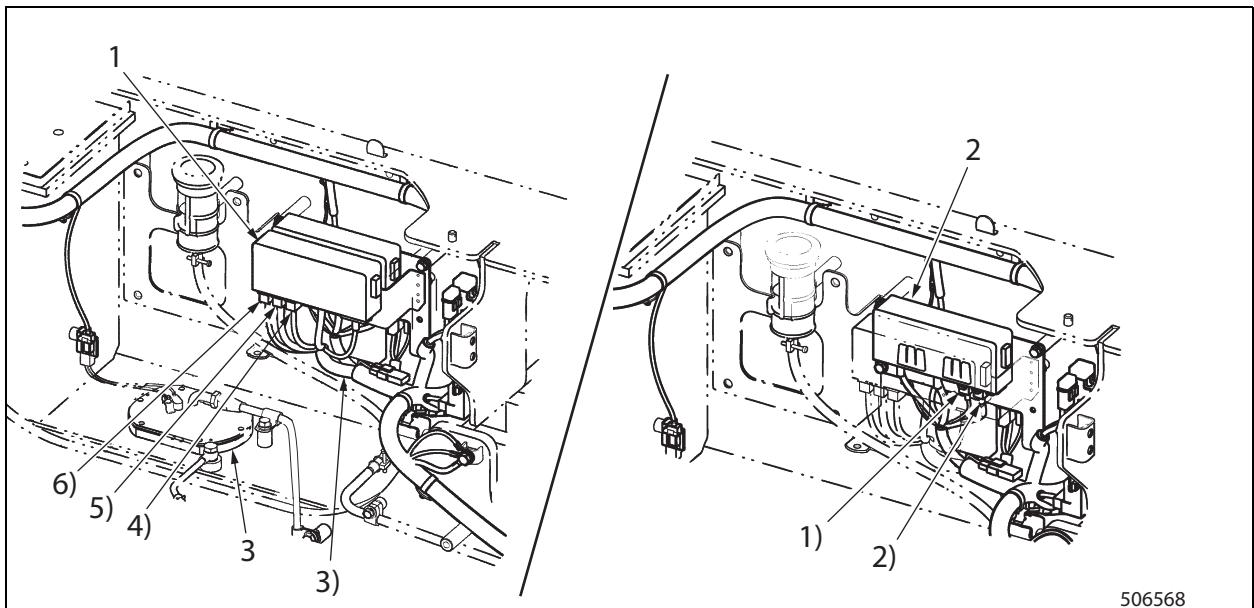

506568

- | | |
|-------------------|-----------------|
| 1. Fuse box | 3) Red tape |
| 2. Relay box 1 | 4) Color: Blue |
| 3. Fuel tank unit | 5) Color: Red |
| 1) Color: Blue | 6) Color: Black |
| 2) Color: Red | |

Turn signal switch connection table

Lever position	Terminal	T-1	T-2	T-3
	Destination	Flash unit	Turn signal light (R side)	Turn signal light (L side)
R (RIGHT turn)		○-----	-----○	
N (NEUTRAL)				
L (LEFT turn)		○-----	-----	-----○

The LCD screen layout consists of six areas: main display, fuel gauge display, travel direction display, symbol display, clock/hour meter display, and coolant temperature display. Main display is divided into right and left parts.

Note: The meter panel has functions below to protect circuits in the panel.

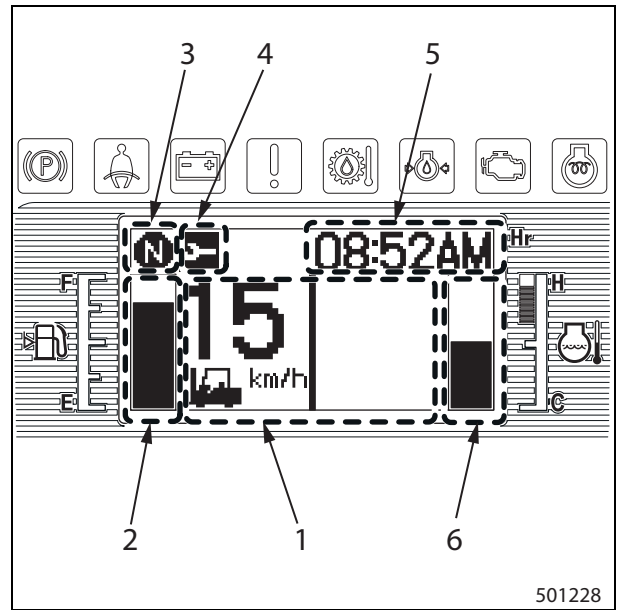

- 1. Main display
- 2. Fuel gauge display
- 3. Travel direction display
- 4. Symbol display (option)
- 5. Clock/hour meter display
- 6. Coolant temperature gauge

Meter panel inside (environment) temperature	-
85° C (185° F) or higher	LCD display on the screen automatically hides.
105° C (221° F) or higher	LCD backlight goes off automatically.

Note:

- The LCD backlight illuminates the LCD screen from behind around the fuel mark (left side) and coolant temperature mark (right side).
- For safety, warning icons will not go OUT automatically.
- When the temperature is extremely low (0° C or below), the response of the LCD display becomes slower.

Warning display according to fault level

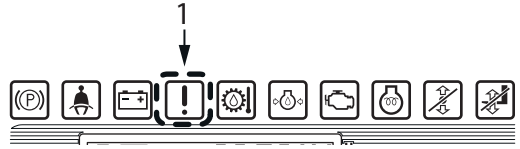
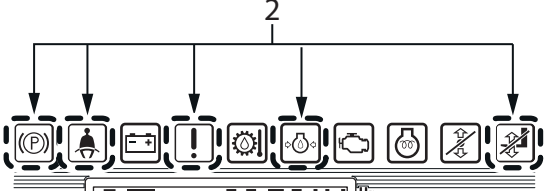
<p>Minor warning</p>	<p>Multi-purpose warning icon 1 glows</p>	 <p>506528</p>
<p>Serious warning</p>	<p>All of the five warning icons 2 blink</p>	 <p>506529</p>

CAN wiring diagram

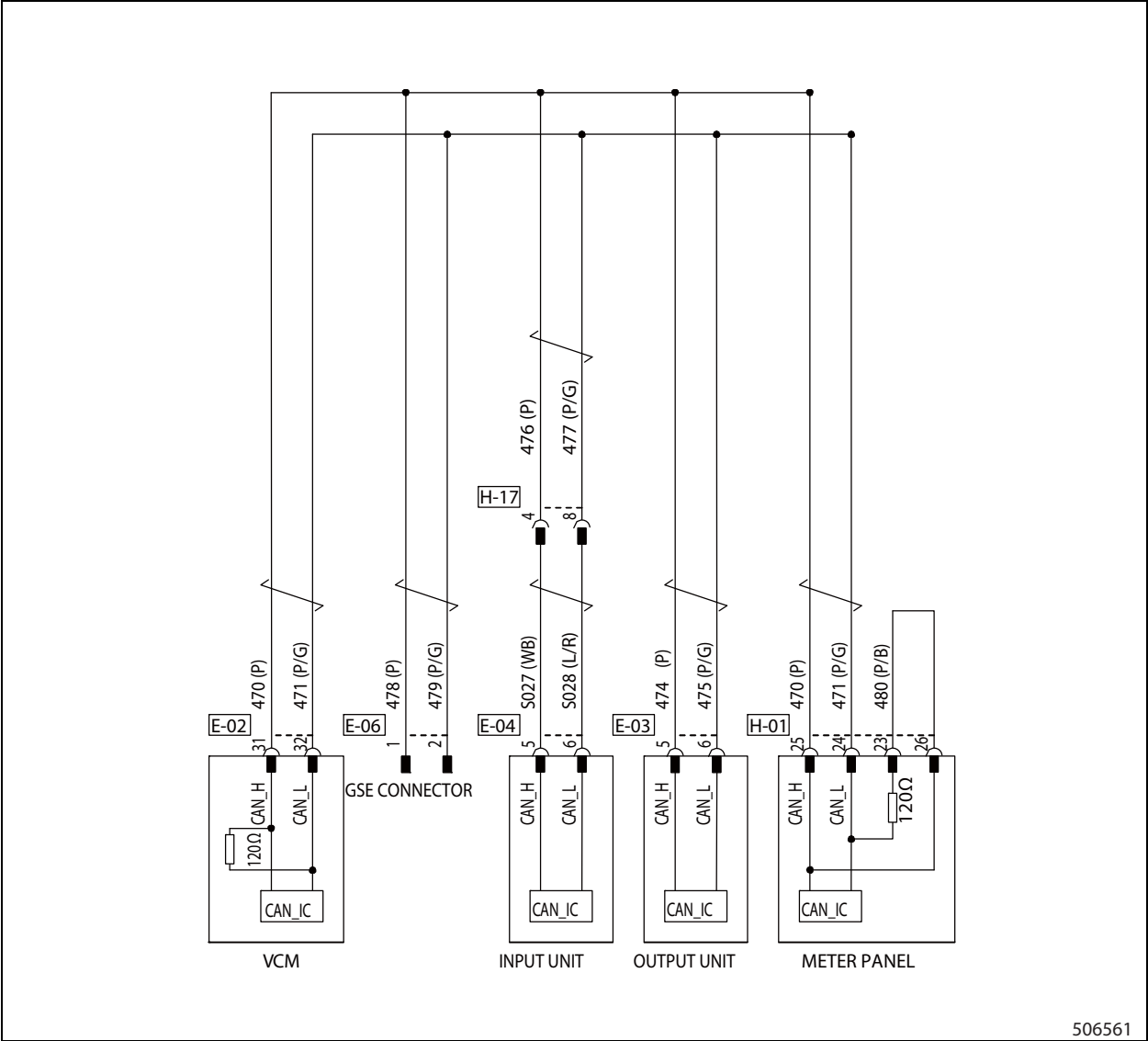

506561

4.8 Attachment 1 Lever Neutral Warning (F12)

Diagnostic code: F12	
Situation	"F12" blinks. All load handling operations disabled.
Possible cause	Load handling lever operated when turning ON key switch. Faulty attachment 1 lever, faulty input unit, or faulty harness.
How the code is triggered	Attachment 1 lever is not in NEUTRAL when turning ON key switch.
Recovery	Auto recovery when the attachment 1 lever is placed in NEUTRAL.
Action	Turns OFF all solenoid outputs of operating functions.

Checks

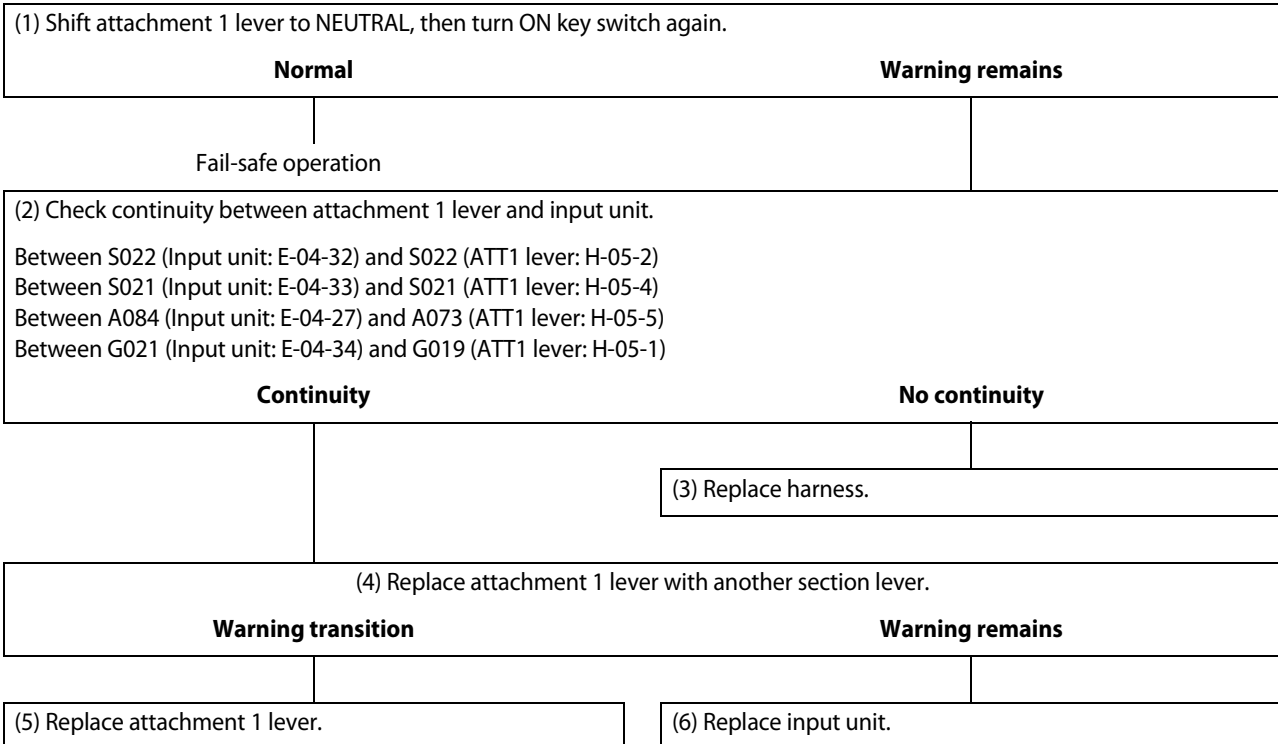

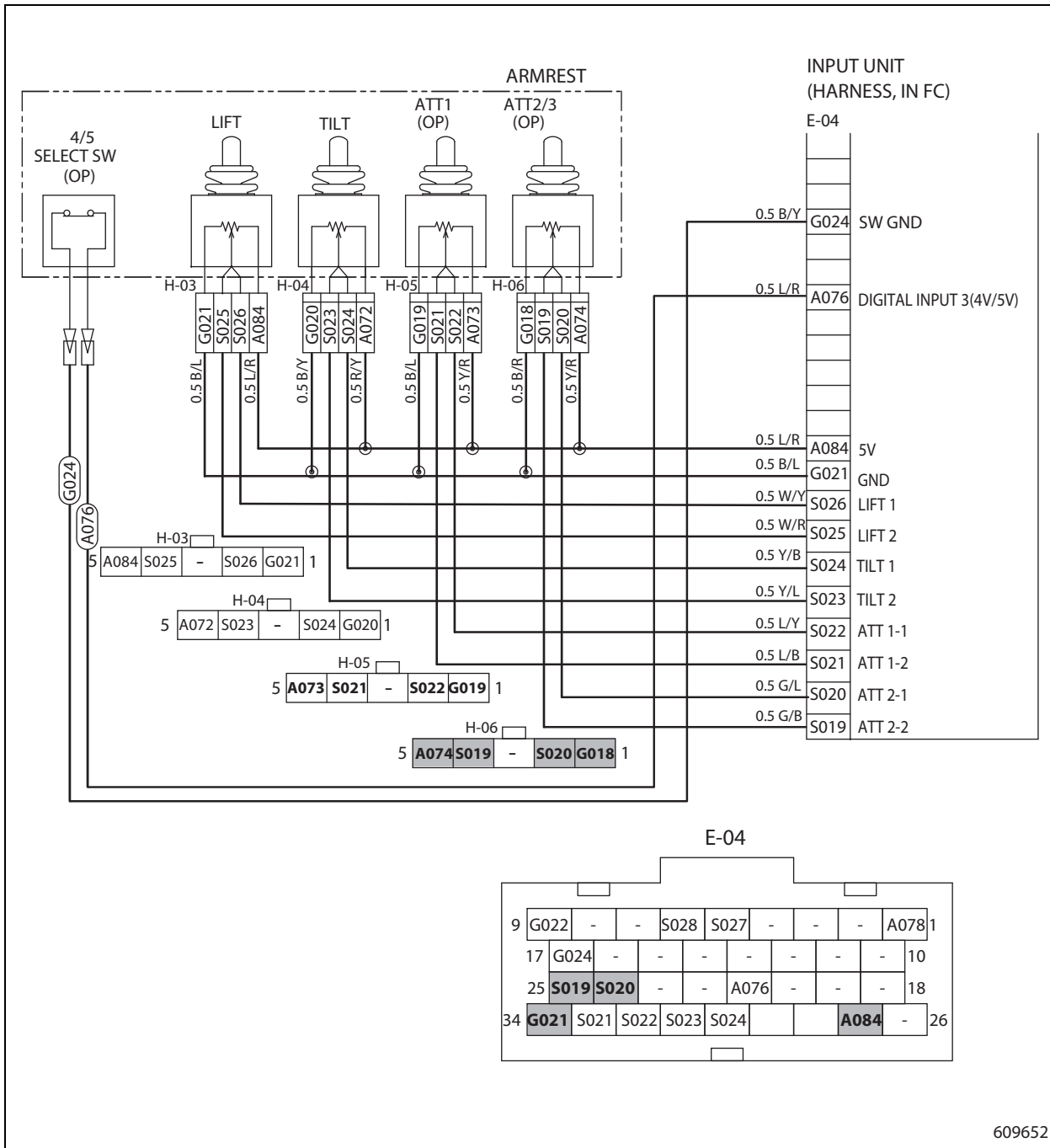

609652

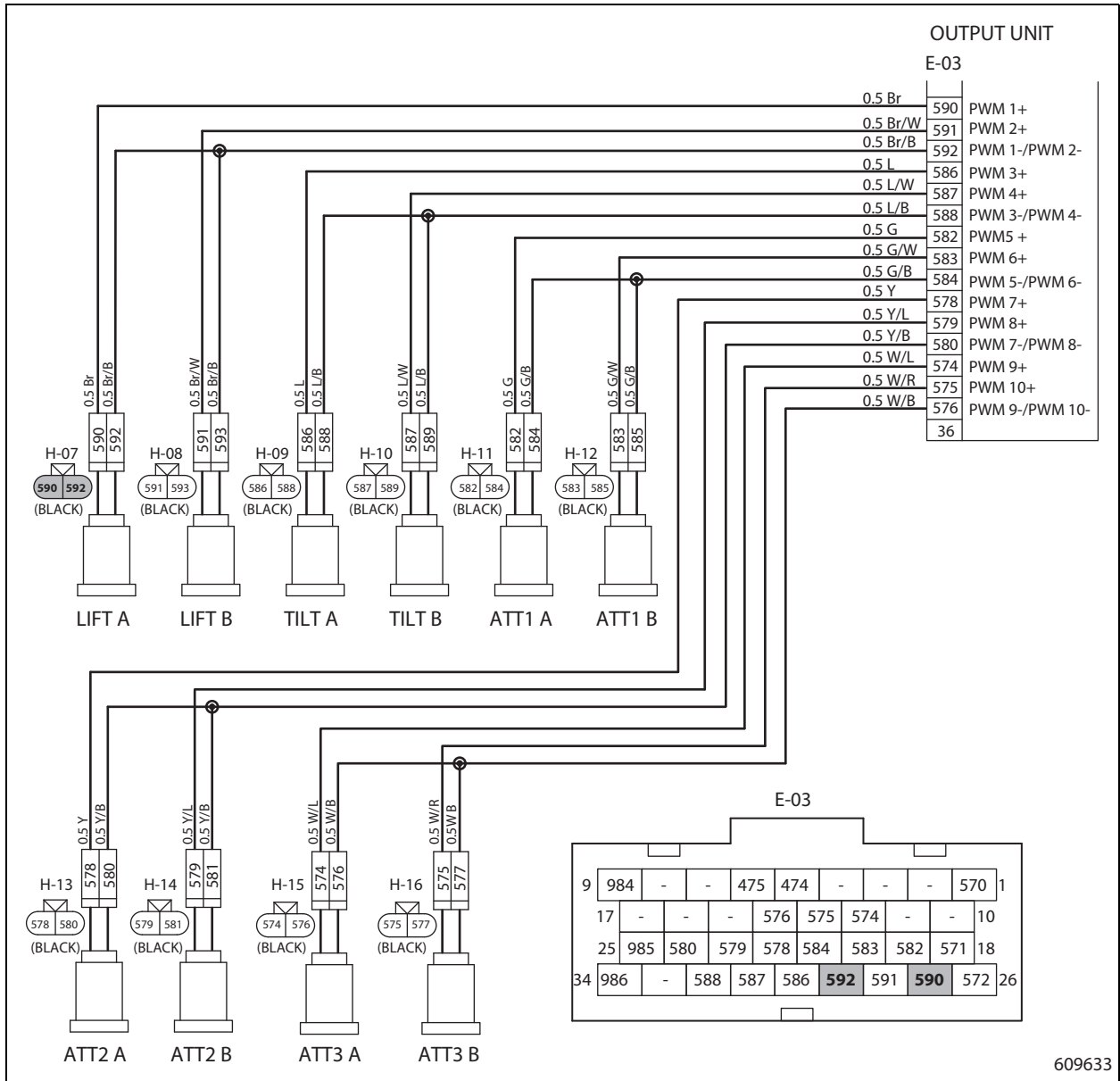

609633

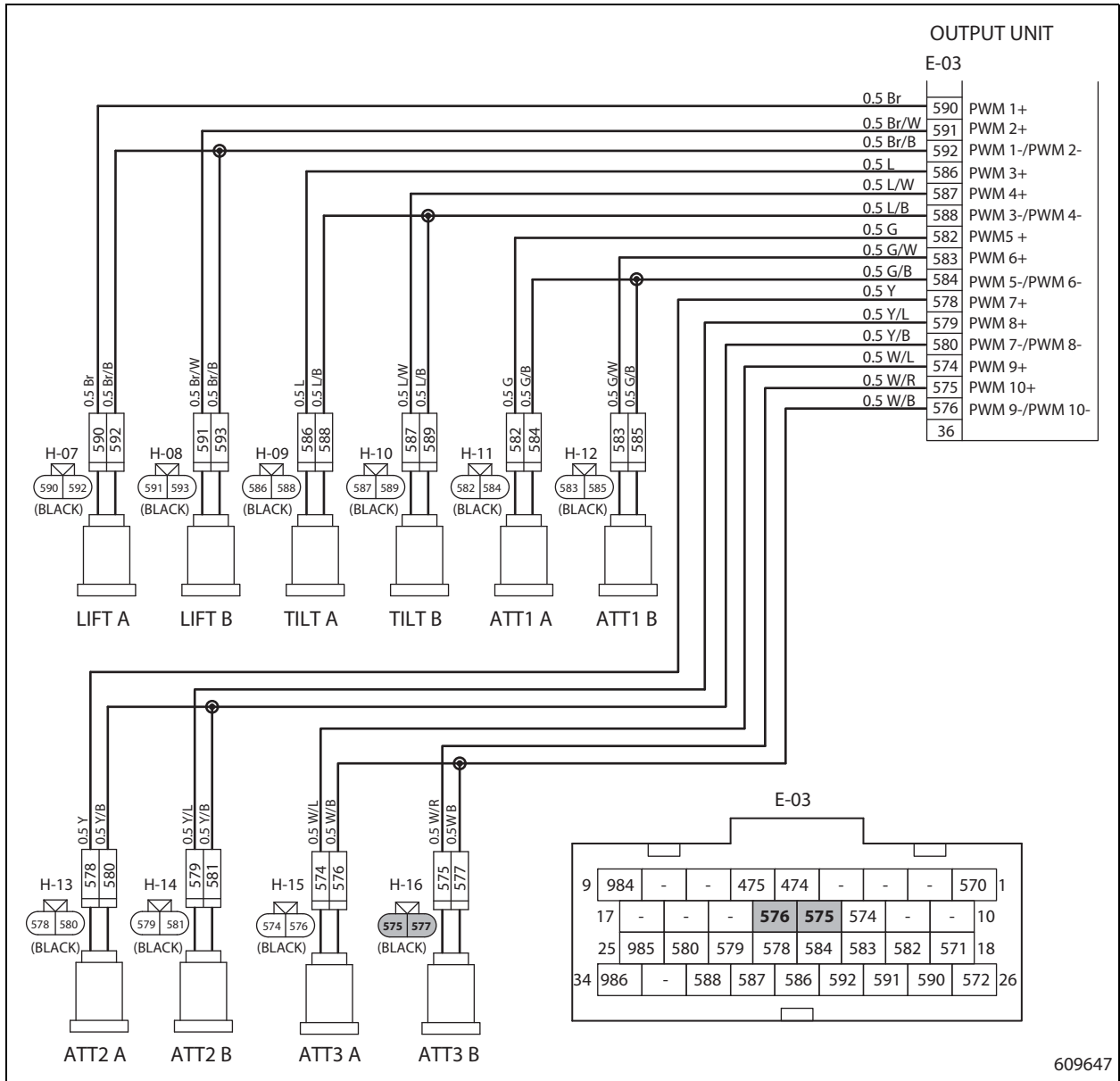

609647

4.46 VCM Speed Change Solenoid 1 Warning (F93)

Diagnostic code: F93	
Situation	"F93" blinks. Speed change control disabled (gear fixed and will not move to another gear).
Possible cause	Faulty VCM, faulty speed change solenoid 1, or faulty harness.
How the code is triggered	Current is 0.6A or less, when speed change solenoid 1 signal is output.
Recovery	Key OFF/ON.
Action	Turns OFF speed change solenoid 1 outputs.

Checks

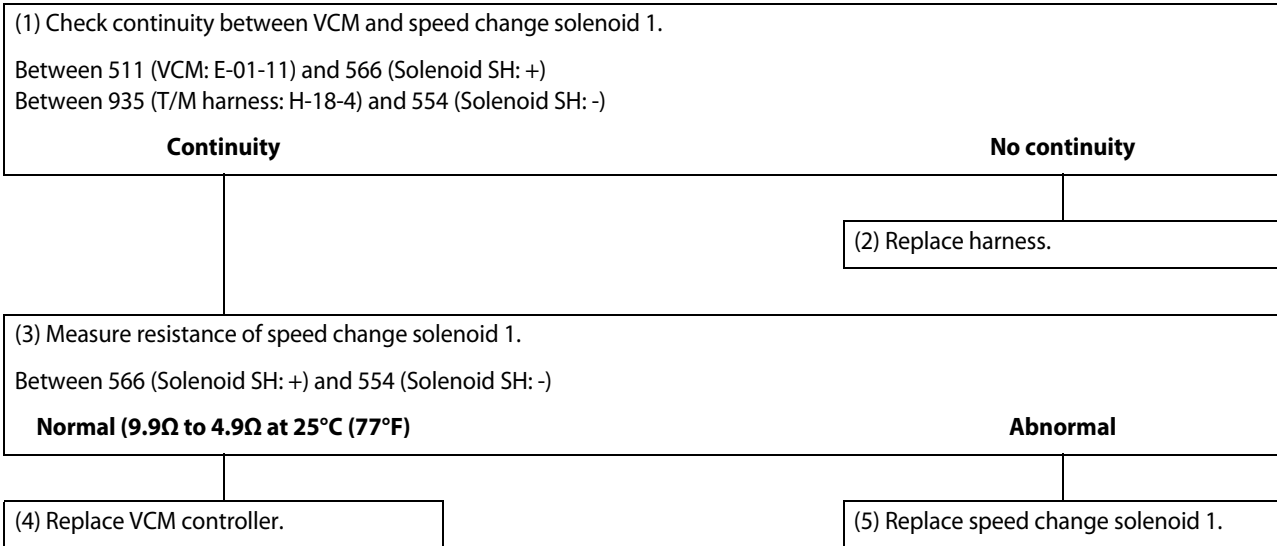

- (9) Bleed air from the fuel system. (See Operation and Maintenance Manual.)
- (10) After completing the tightening, turn the engine ON to check the vibration. If there is too much vibration, tighten the mounting bolts further and verify that the vibration is reduced.
- (11) Make sure the safety around the lift truck, and verify the correct assembly by performing the steering and handling operations.
- (12) Turn the engine OFF and check the level of the oils and cooling water. Refill if required.
- (13) Check the transmission speeds and forward/reverse travel operation.

⚠ WARNING

Because the front tires will rotate, provide a barrier around the lift truck to prevent the access of unauthorized people.

Checking the transmission speeds and forward/reverse travel operation

- (1) Tilt the mast fully backward, and place wood blocks under the outer mast.
- (2) Tilt the mast forward to raise the front wheels off the ground.
- (3) Place jack stands under the frame to support the lift truck.
- (4) Block rear wheels.
- (5) Run the engine at low idling speed. Operate the transmission shift lever and check the direction of wheel rotation.
- (6) Operate the travel speed change switch to make sure the rotational speed of the front tires will change accordingly.

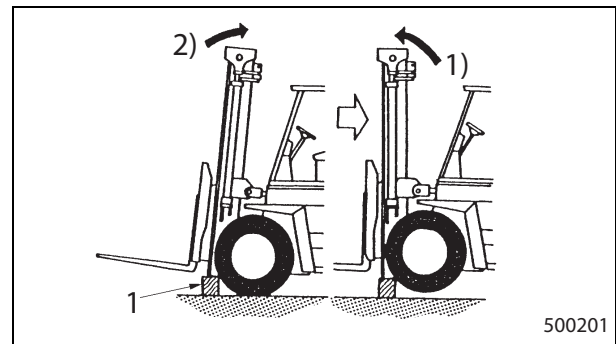

1. Wood block
1) Forward tilt

2) Backward tilt

5.2 Capacity and Brand of Oils and Cooling Water

See "14. Service data"

Ref.	Item	Standard	Limit
1	Outside diameter of clutch hub	67.951 to 67.97 mm (2.6752 to 2.6760 in.)	67.8 mm (2.669 in.)
2	Outside diameter of clutch roller	10.185 to 10.2 mm (0.4010 to 0.402 in.)	10.1 mm (0.398 in.)
3	Thickness of thrust washer	4.95 to 5 mm (0.1949 to 0.20 in.)	4.8 mm (0.189 in.)
4	Thickness of thrust washer	3.95 to 4 mm (0.1555 to 0.16 in.)	3.8 mm (0.150 in.)
5	Thickness of thrust washer	2.9 to 3 mm (0.114 to 0.12 in.)	2.8 mm (0.110 in.)
6	Thickness of thrust washer	4.9 to 5 mm (0.193 to 0.20 in.)	4.8 mm (0.189 in.)
7	Thickness of thrust washer	4.95 to 5 mm (0.1949 to 0.20 in.)	4.8 mm (0.189 in.)

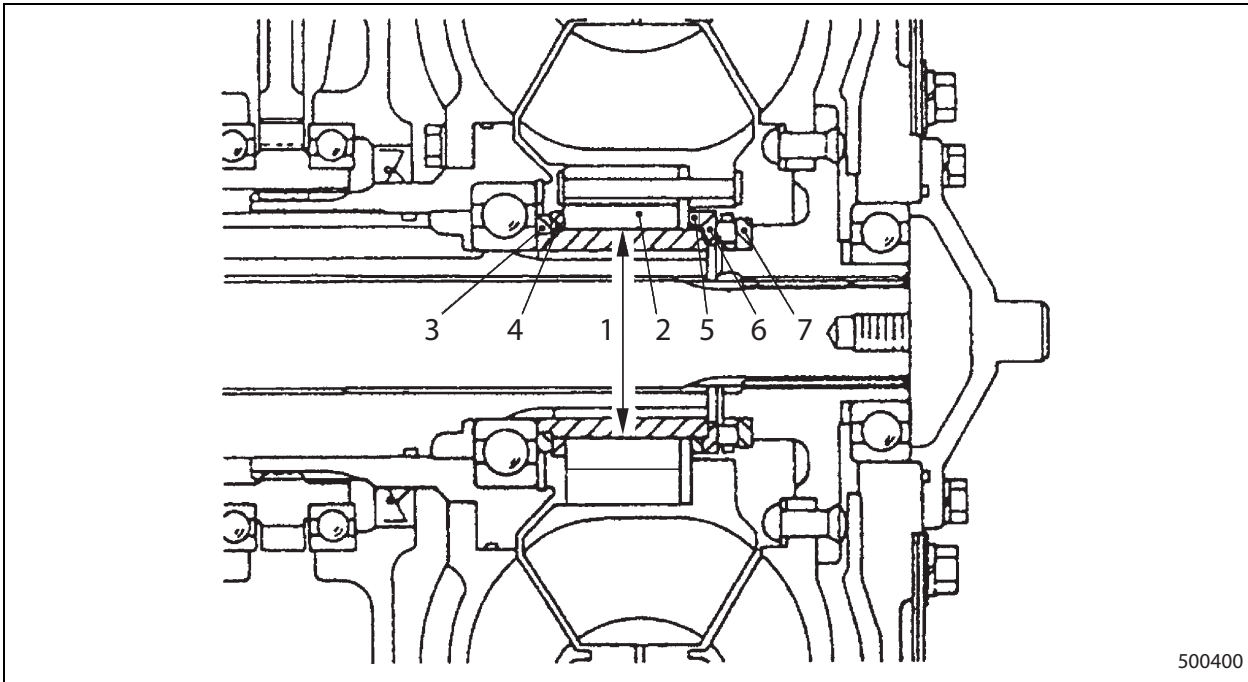

9. Inspecting and Repairing Transmission

Oil pump

- (1) Install the internal gear and pump gear to the pump case, and measure the top clearance.
- (2) Measure the side clearance between the gear and pump case with a dial gauge.

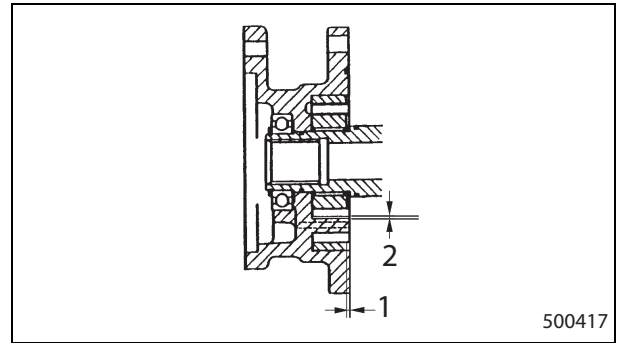

Ref.	Item	Standard	Limit
1	Side clearance	0.040 to 0.078 mm (0.0016 to 0.0031 in.)	0.09 mm (0.0035 in.)
2	Top clearance	0.3 to 0.345 mm (0.012 to 0.0136 in.)	0.35 mm (0.0138 in.)

Stator shaft

Check the stator shaft and make sure that the stator shaft is free from the following defects:

- Thread damage of spline
- Clogged oil passages

Friction plate and mating plate

Check the friction plates and mating plates and make sure that they are free from the following defects. If any of them is defective, replace all plates with new ones.

- Seizure, local contact, distortion, and wear
- Wear and damage of splines

Clutch drums of forward, reverse, and 1st/3rd speed clutches

Check the shafts and clutch drums and make sure that they are free from the following defects:

- Wear and damage of mating plate sliding surfaces
- Wear and damage of clutch piston sliding surfaces

17. Adjustment

17.1 Adjusting Brake Pedal and Inching Pedal

- (1) Set the inching pedal height to 178 mm (7.01 in.) by adjusting the bolt and nut.
The inching pedal will be set at an angle of $45^{\circ} \pm 1.0^{\circ}$.
- (2) Set the height of the brake pedal equal to the height of the inching pedal by adjusting the bolt and nut.
- (3) Set the clearance between the inching pedal and the brake pedal to zero (0) by adjusting the bolt and nut.

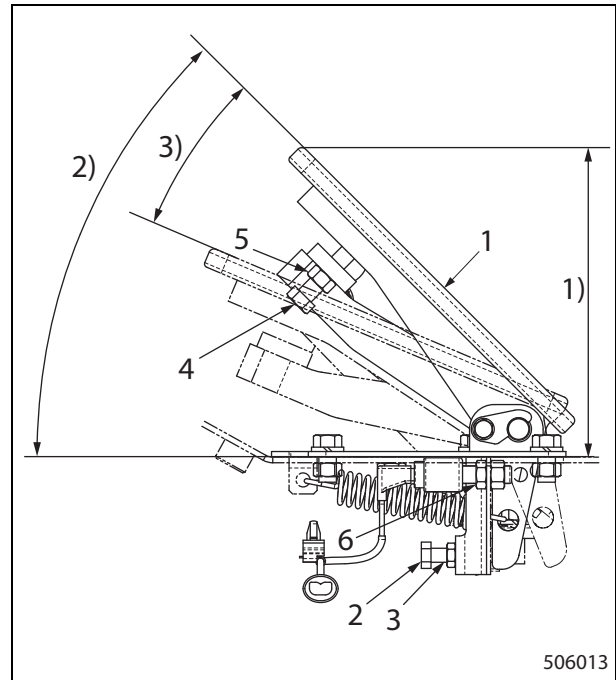

- | | |
|------------------|--|
| 1. Inching pedal | 6. Nut |
| 2. Bolt | 1) 178 mm (7.01 in.) (Pedal height) |
| 3. Nut | 2) $45^{\circ} \pm 1.0^{\circ}$
(Pedal set angle) |
| 4. Bolt | 3) 22° (Stroke) |
| 5. Nut | |

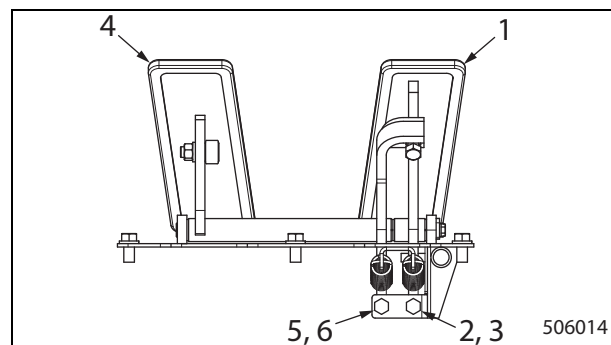

- | | |
|------------------|----------------|
| 1. Inching pedal | 4. Brake pedal |
| 2. Bolt | 5. Bolt |
| 3. Nut | 6. Nut |

19.6 Flexible Plate

Ref.	Item		Value
1	Flexible plate face runout (In free state)	Standard	0.2 mm (0.008 in.)
		Limit	0.5 mm (0.020 in.)
2	Distance between end face of case and mating face of flexible plate	Standard	14.5 mm (0.571 in.)

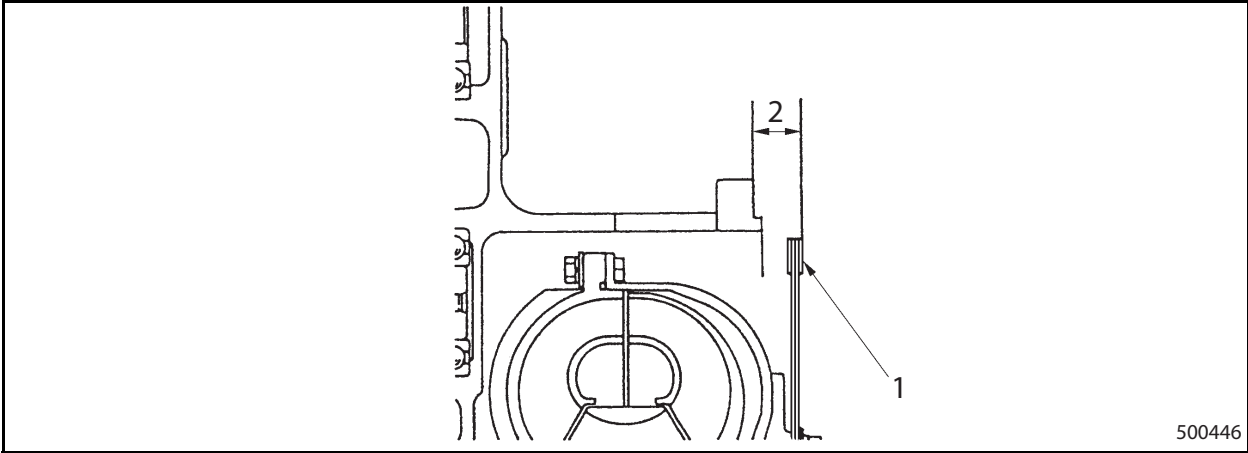

5. Removing Front Axle and Reduction Differential

5.1 Preparation

- (1) Block the rear wheels.
- (2) For removal of the mast assembly, see "12. Mast and Forks".
- (3) Remove the front wheels, referring to 7-4 "Removing Front Wheels".
- (4) Place jack stands under the frame to prevent the forklift truck from falling.
- (5) Drain the front axle oil as instructed below:
Place containers sufficient for the quantity of oil under each drain, then drain the oil by removing the drain plugs of the axle housings and wheel hub covers.
To drain oil from the wheel cover, turn the wheel axle to bring the drain plug (right or left) of wheel hub cover to the lowest position. Remove the plug positioned above the wheel center line to drain air.

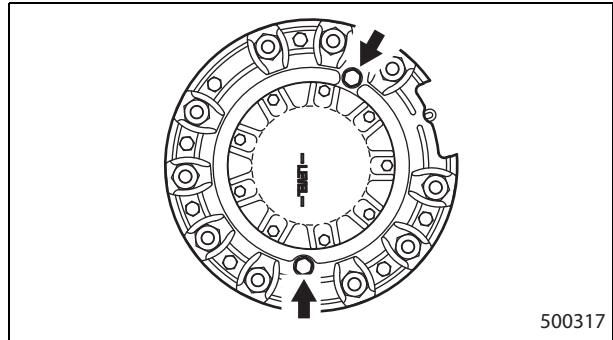

Capacity
Approximately 25 L (6.61 US gal.)

11. Disassembling Reduction Differential

11.1 Preparation

Measuring backlash

Unless replacing the reduction gear set, measure the backlash between the reduction gear and the reduction pinion before disassembly for their later assembly.

Note: When the reduction gear set is to be replaced with a new one, measurement of backlash is unnecessary.

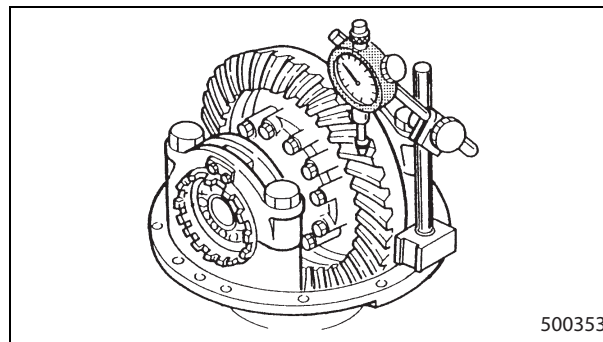

500353

Item	Standard
Backlash between reduction gear and pinion	0.25 to 0.33 mm (0.0098 to 0.0130 in.)

Matchmark

Put a matchmark on the bearing cap, adjusting screw, and the carrier to ensure correct assembly.

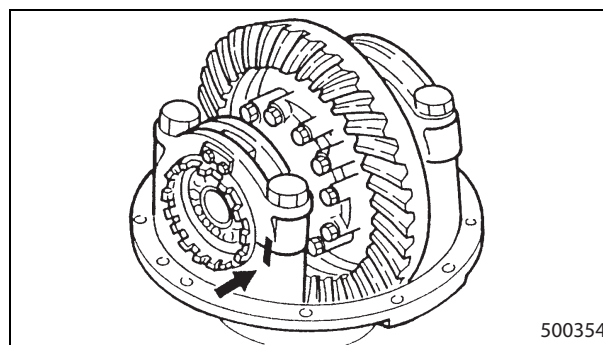

500354

12.6 Assembling Reduction and Parking Brake Assembly

O-ring and oil separator for each part

Apply the service oil before assembly.

Oil seal

Prepare the following special tool.

Installer: To be made by dealer (for the dimensions, see the illustration on the right).

- Place the main lip of oil seals inward and apply grease and oil between the lips.
- Put the oil seal on the installer and insert it into the parking brake bracket.

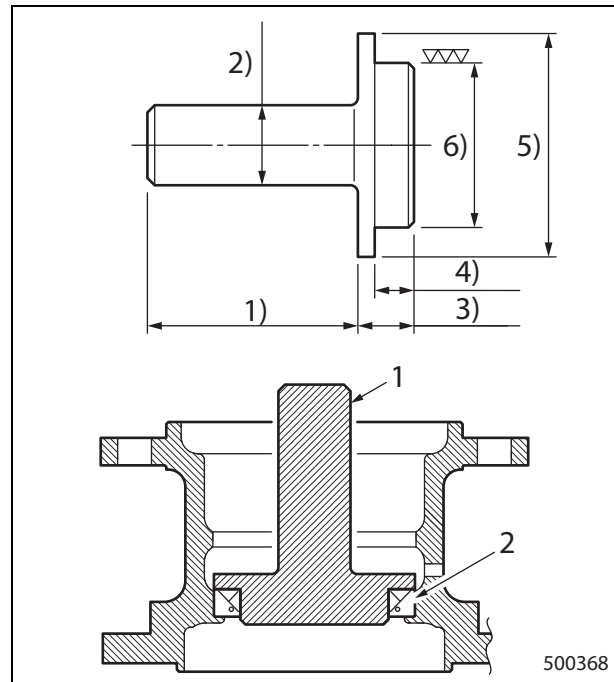

- | | |
|-------------------------------|---|
| 1. Installer | 3) 23 mm (0.91 in.) |
| 2. Oil seal | 4) 15 mm (0.59 in.) |
| 1) 130 mm (5.12 in.) | 5) $\text{Ø}95 \begin{smallmatrix} 0 \\ -0.1 \end{smallmatrix}$ mm (3.74 $\begin{smallmatrix} 0 \\ -0.004 \end{smallmatrix}$ in.) |
| 2) $\text{Ø}35$ mm (1.38 in.) | 6) $\text{Ø}68.5 \pm 0.1$ mm (2.7 ± 0.004 in.) |

Parking brake assembly

- (1) Exercise care for the direction of the parking brake lever when assembling.
- (2) Tighten the mounting bolts to the specified torque.

Tightening torque
145 ± 22 N·m (14.8 ± 2.2 kgf·m) [106.95 ± 16.23 lbf·ft]

Parking brake drum

Tighten the mounting nuts to the specified torque.

Tightening torque
96 ± 15 N·m (9.8 ± 1.5 kgf·m) [70.81 ± 11.06 lbf·ft]

Self-locking nut

- (1) Apply LOCTITE[®] 271 to the self-locking nut and tighten it to the specified torque.

Tightening torque
294.2 ± 29.4 N·m (30.00 ± 3.00 kgf·m) [216.991 ± 21.684 lbf·ft]

- (2) Torque caulk the nut with a punch after tightening.

Steering hose

- (1) Remove the hoses at the power steering cylinder sides.
- (2) Put a sealing plug on the fitting of the disconnected hose to prevent oil from flowing out.

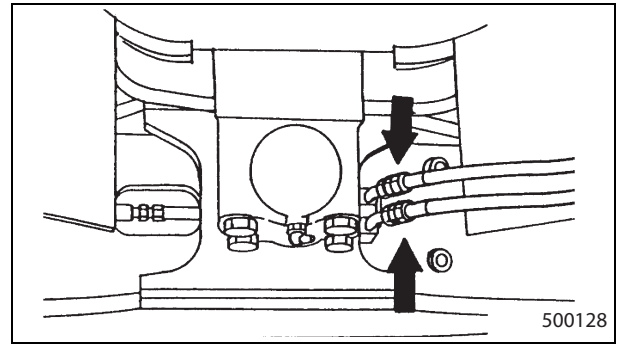

Item	Part number
Sealing plug	05530-30300 (G 3/8)

⚠ WARNING

Carefully operate the jack so that the rear axle does not accidentally drop off.

Rear axle assembly

- (1) Prepare a jack, etc. having a wide supporting range.
- (2) From the rear of the forklift truck, position the jack under the rear axle and secure it with a wire rope, etc.
- (3) Remove the rear axle supports at front and back.
- (4) Operate the jack to lower the rear axle and pull it out diagonally backward.

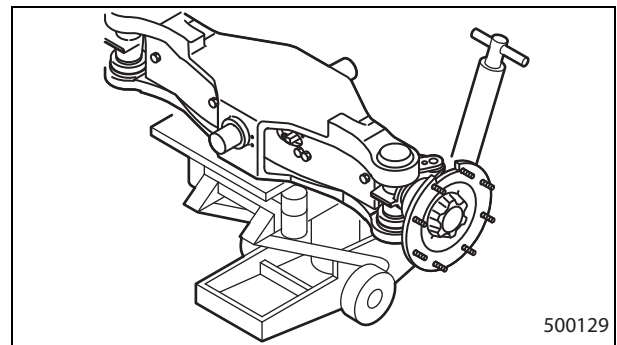

Item	Weight
Rear axle Casting housing type	Approximately 790 kg (1741.7 lb.)

Rear axle support

- (1) Do not remove the bushings in the support unless any defect is found through inspection.
- (2) If any defect is found, either replace the rear axle support as a whole assembly or break the bushing to remove it.

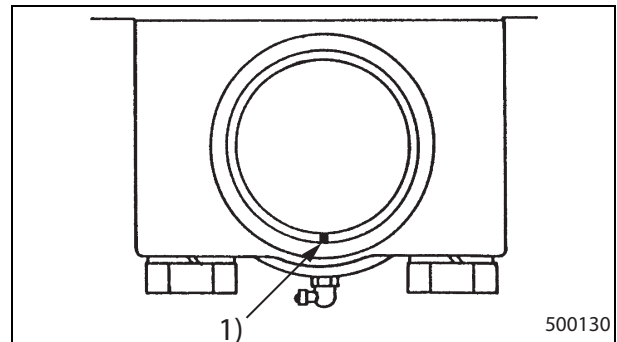

1) Seam of bushing

⚠ CAUTION

To install a new bushing, orient the seam part of the bushing in the lower side (grease nipple side).

12. Adjustment

12.1 Measuring Minimum Turning Radius

- (1) Secure level ground of 20 by 20 meters (21.9 by 21.9 yd) or more.

⚠ WARNING

The area where the measurement to be taken must be surrounded by a fence, etc. or assigned with a watchman so that no unauthorized persons gain access to the area.

- (2) Attach a piece of chalk on the end of a thread, and hang it down from a position of the counterweight to the ground as shown in the illustration.
- (3) Turn the steering wheel fully and drive the forklift truck at a low speed. At this point, make sure that the chalk draws a line (circle) on the ground.
- (4) Measure the diameter of the circle drawn on the ground. The radius of this circle is assumed to be the minimum turning radius (R).

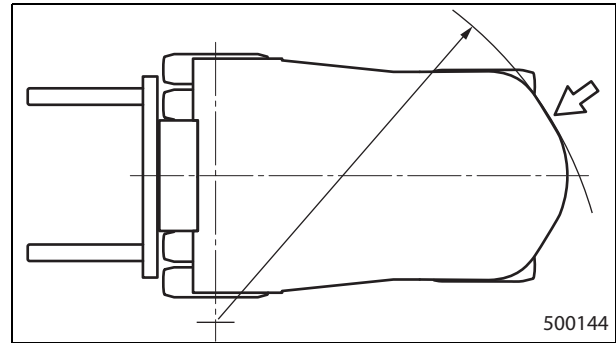

Truck model	Minimum turning radius
FD100NM1 FD100NM1S	4000 ⁺³⁰⁰ ₋₅₀ mm (157.48 ^{+11.8} ₋₂ in.)
FD120NM1 FD120NM1S	4060 ⁺³⁰⁰ ₋₅₀ mm (159.84 ^{+11.8} ₋₂ in.)
FD135NM1 FD135NM1S	4160 ⁺³⁰⁰ ₋₅₀ mm (163.78 ^{+11.8} ₋₂ in.)
FD150ANM1 FD150ANM1S	4550 ⁺³⁰⁰ ₋₅₀ mm (179.13 ^{+11.8} ₋₂ in.)

2.6 Air Master

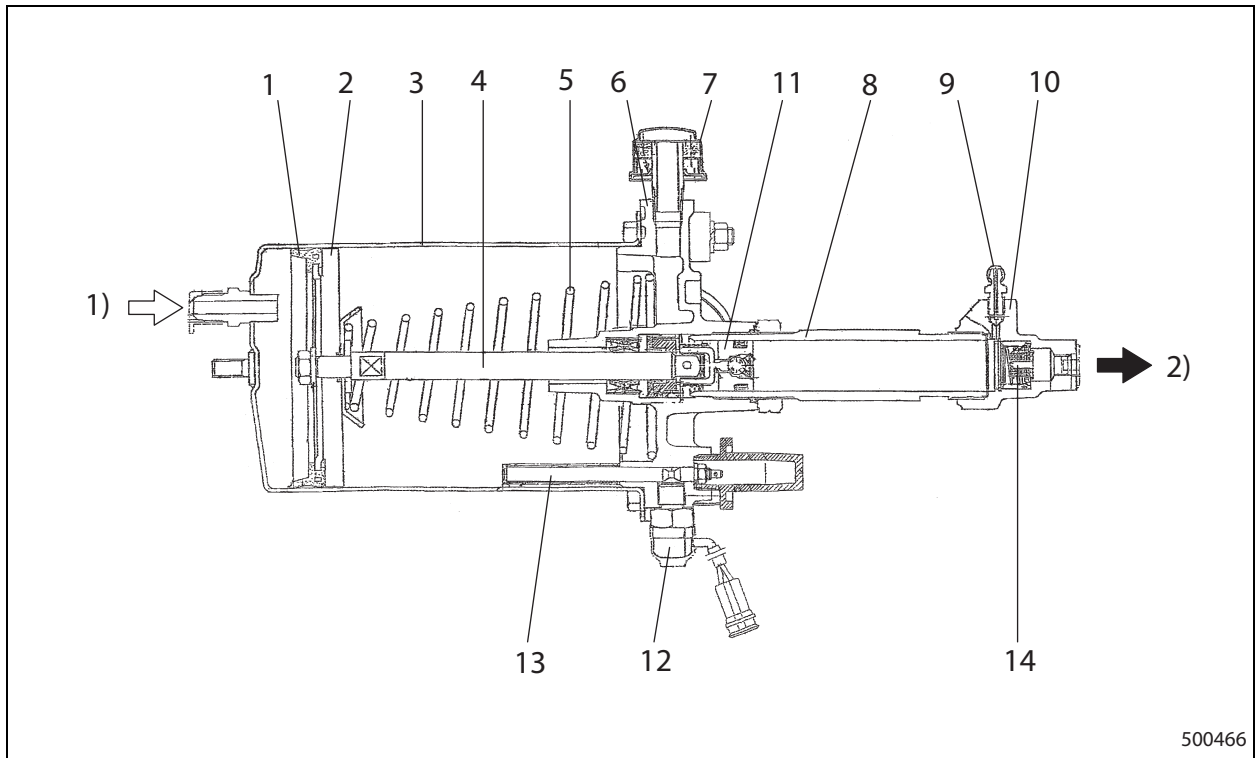

- | | |
|-----------------------|--|
| 1. Piston packing | 9. Breather plug |
| 2. Piston plate | 10. Cylinder cap |
| 3. Cylinder shell | 11. Hydraulic piston assembly |
| 4. Push rod | 12. Switch assembly |
| 5. Return spring | 13. Rod and plate assembly |
| 6. End plate | 14. Outlet valve |
| 7. Air breather | 1) From brake control valve (compressed air) |
| 8. Hydraulic cylinder | 2) To wheel brakes (high pressure fluid) |

Brake fluid pressurized by the compressed air supplied from the brake control valve is used to activate the wheel cylinder.

7.2 Suggestions for Assembly

Applying grease

Apply a thin coat of specified brake grease on the following parts:

- Apply grease on the fitting area of the adjusting cam and wheel cylinder to the anchor bracket before assembling.
- Apply grease on the fitting area of the anchor pin to the anchor bracket and the inside faces of shoe bushing before assembling.

Note: Do not allow grease to protrude into the drum.

Installing wheel cylinder

- (1) Apply a thin coat of liquid gasket on the mounting surface of cylinder.
- (2) Align the oil filler port surface on the cylinder with the dust cover side face of anchor bracket, and tighten the bolt to the specified torque.

Tightening torque
45 to 69 N·m (4.6 to 7.0 kgf·m) [33.19 to 50.89 lbf·ft]

Installing brake shoe

- (1) Minimize the eccentricity of the right and left adjusting cams.
- (2) Verify that each push rod of the wheel cylinder is correctly inserted into the shoe web.

Installing lockplate and lockwasher

- (1) Tighten the mounting bolts to the specified torque.
- (2) After installing, bend the lockplate without fail.

Tightening torque
15.7 to 23.6 N·m (1.60 to 2.41 kgf·m) [11.580 to 17.406 lbf·ft]

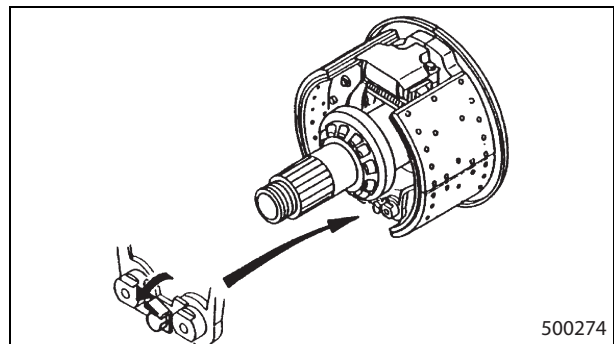

23. Adjusting and Testing Actuation

23.1 Inspecting Wheel Brake

Clearance between lining and drum

- (1) Remove the grommet covering the inspection hole of dust cover.
- (2) Insert a thickness gauge between the lining and drum through the inspection hole, and check the thickness of the gauge which feels a little drag to insert and pull out.
- (3) If the thickness is out of the standard, adjust the clearance by turning the adjusting cam.

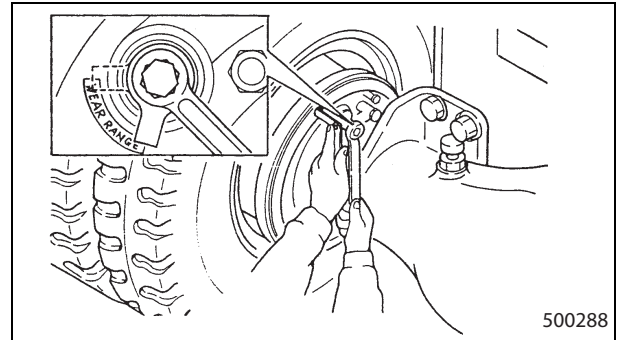

Item	Standard
Clearance between lining and drum	0.2 mm (0.008 in.)

⚠ CAUTION

Check two places in a wheel.

Replacing brake lining

Replace the shoes as an assembly when the brake lining wear indicator shows the limit of service. And also replace the linings in the cases as below:

- If the lining and brake shoe are not properly assembled.
- If the lining is significantly contaminated by oil, or glazed by heating.
- If the lining shows cracks or damage.

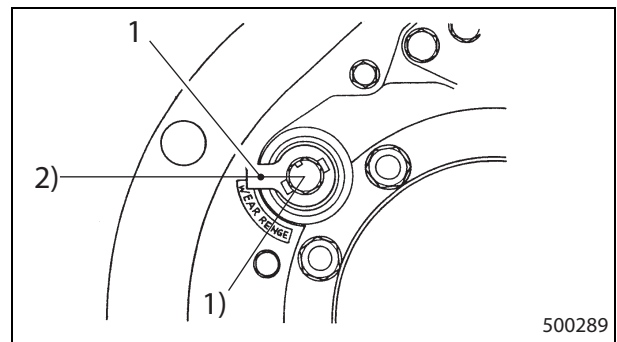

1. Wear indicator

1) Adjusting position (position without wear)

2) Service limit position

Adjusting lining wear indicator

Perform the adjustment of indicator only when the adjusting cam was disassembled.

To set the lining wear indicator, place the pointer to the inner most position of lining wear range by turning the washer with a wrench.

In this case, set the adjusting cam to place the shoes at the most retracted position, and hold the adjusting cam not to turn with another wrench.

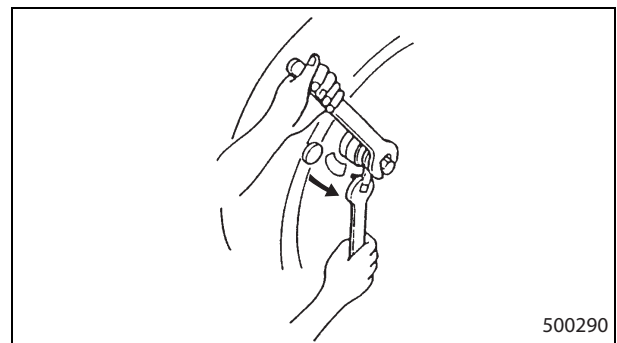

Chapter 10 STEERING SYSTEM

1. Specifications

Item		Specification
Steering type		Full-hydraulic power steering
Steering control valve	Displacement volume	369 cm ³ (22.5 in. ³) /rev
	Rated flow	45.4 L (11.995 US gal.)/min
	Max pressure	17.2 MPa (175.4 kgf/cm ²) [2494.7 psi]
Steering wheel outside diameter		320 mm (12.60 in.)

2. Structure

2.1 Steering System

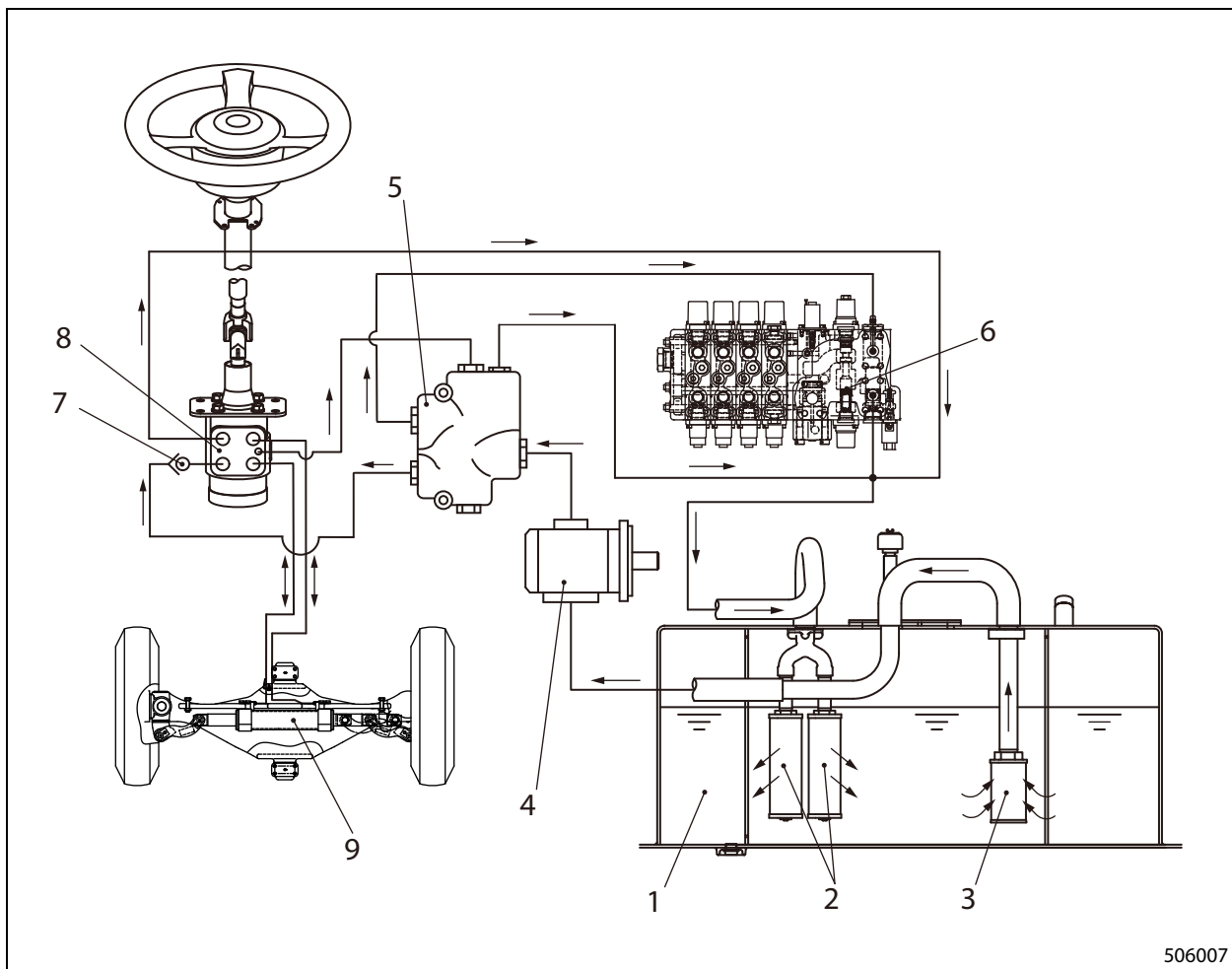

506007

- | | |
|-------------------------|--|
| 1. Hydraulic tank | 6. Control valve for other operation devices |
| 2. Return filter | 7. Check valve |
| 3. Suction strainer | 8. Steering valve |
| 4. Gear pump (Oil pump) | 9. Power steering cylinder |
| 5. Priority valve | |

⚠ CAUTION

Put a matchmark on the spool and sleeve before disassembling.

- (17) Push the spool **2** in sleeve **1** slightly forward and remove the centering springs **3**. Remove the spool from the sleeve by pulling it toward the rear end of the sleeve while turning slowly.

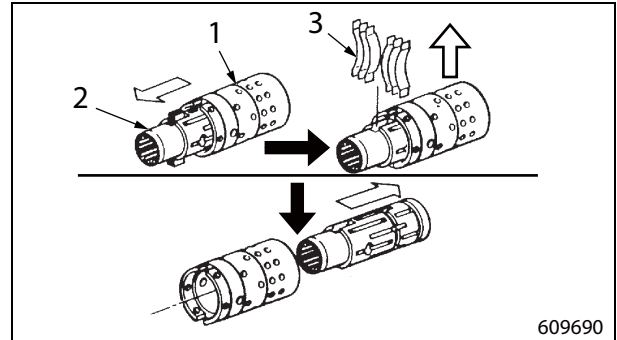

- 1. Sleeve
- 2. Spool
- 3. Centering springs

5.3 Inspecting Steering Valve after Disassembly

Inspect sliding faces between sleeve and housing, and between sleeve and spool.

- (1) Inspect sliding movement in subassembled condition.
- (2) If any unusual sliding movement is detected, inspect sliding surfaces.
If any damage such as wear, scratches, burrs, or rust are found, replace the whole steering valve with a new one.

Five-way valve

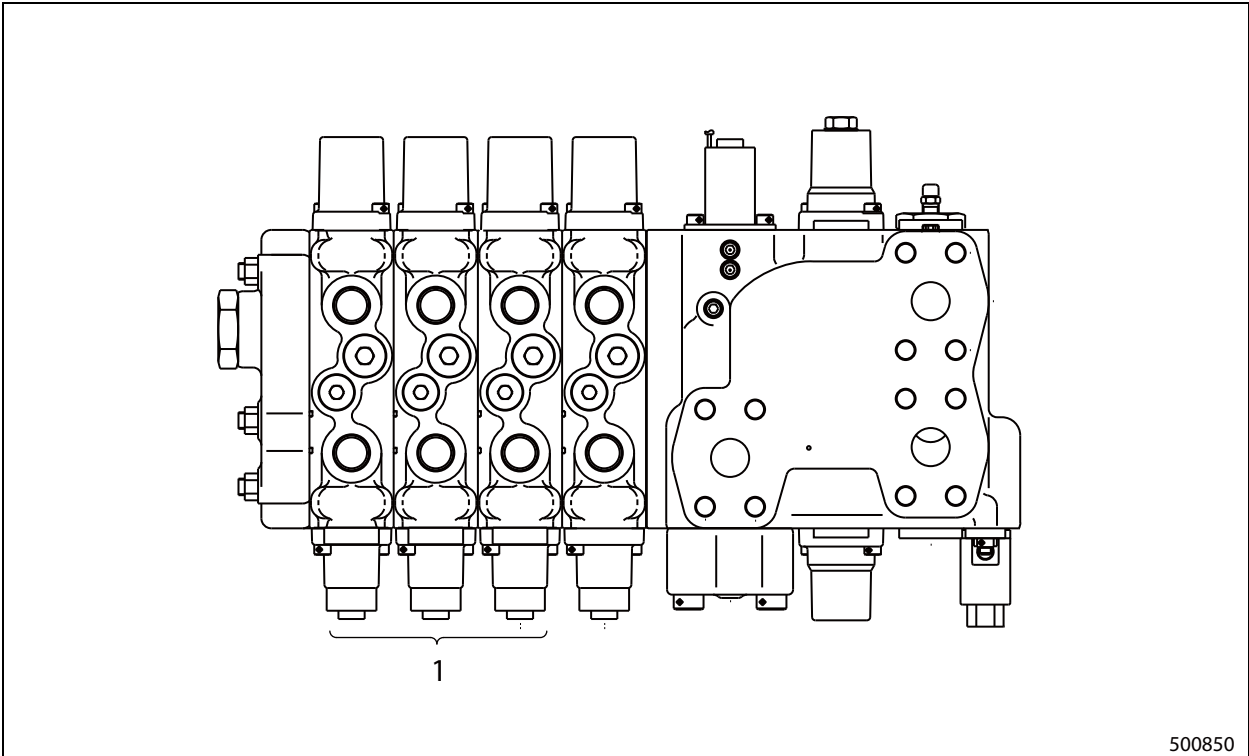

500850

- 1. Attachment valve

Attachment valves can be added to the standard control valves to form a three-way, four-way, or five-way valve.

- (15) Place the cover B on the gear plate and press in lightly. If the cover B stops at the position about 3 mm (0.12 in.) from the gear plate, the positions of the isolation plate, plate seal and backup may be displaced. Check and reassemble. Do not forcibly tap in the cover, or the backup and other parts may break.
- (16) Install the washer to the bolt and tighten the bolt.

Bolt tightening torque
132.4 to 137.2 N·m (13.5 to 13.99 kgf·m) [97.65 to 101.19 lbf·ft] [wet]

- (17) If the oil seal is disturbed, replace it with a new one, and fix with the snapping. Pay attention not to tilt the oil seal to install.
- (18) Hand turn the drive gear shaft to check the effort. If the shaft rotate smoothly the pump is free from inclusion of seal, foreign matter and others. If not, the inclusion is suspected. Disassemble and reassemble.
- (19) Pay attention to the assembling sequence and the rotating direction.

11. Installing Gear Pump

On installing, pay attention to the items blow:

- (1) Check flaw on the installing face for the proper centering.
- (2) Check flaw and dust on the cover mating face. Especially pay attention to the vise clamped positions.
- (3) Check flaw and dust on the piping flange faces.

(3) Tightening torque for parts

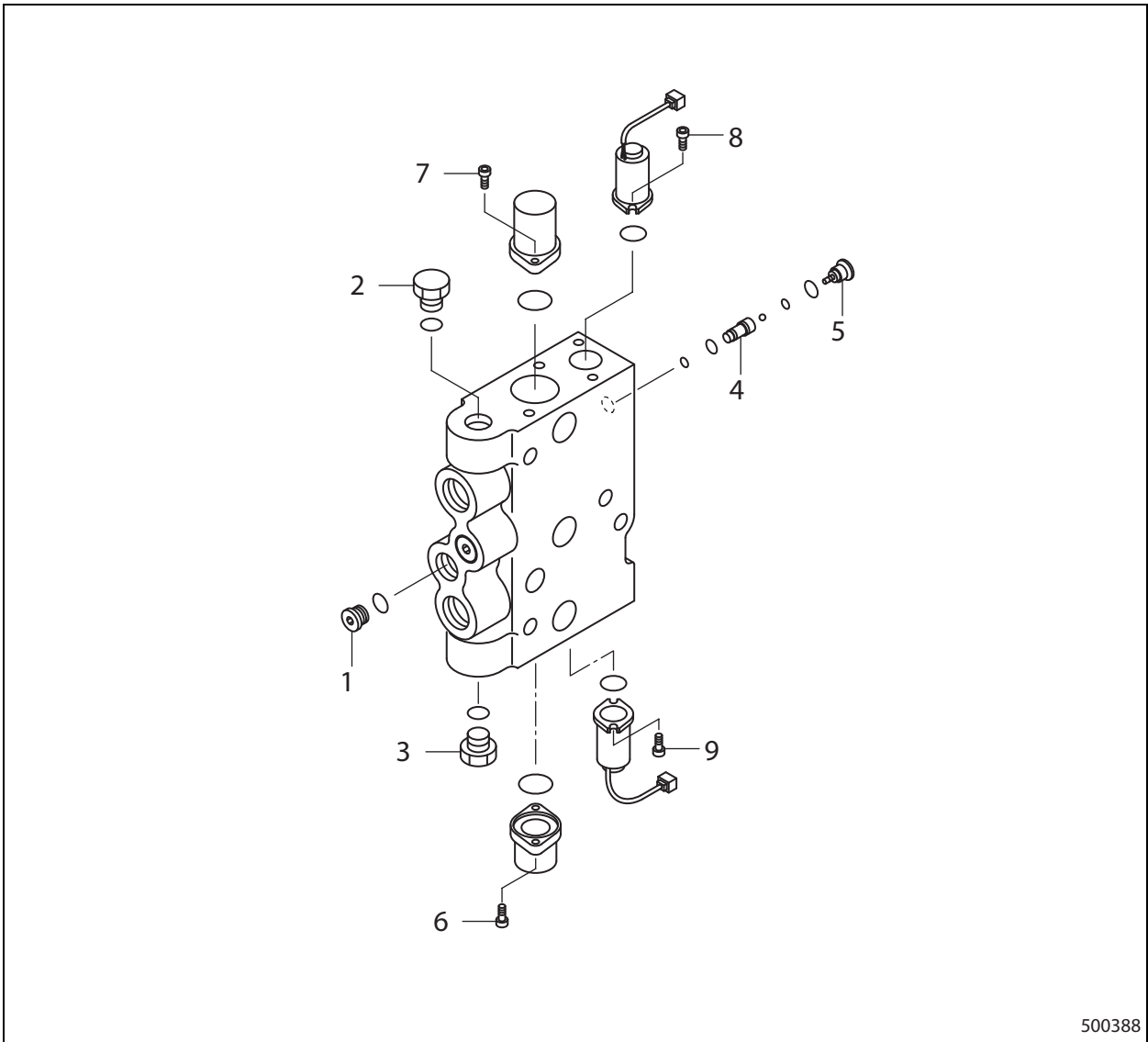

500388

Ref.	Item	Tightening torque
1	Plug	34.3± 3.4 N·m (3.5 ± 0.35 kgf·m) [25.3 ± 2.51 lbf·ft]
2	Plug	34.3± 3.4 N·m (3.5 ± 0.35 kgf·m) [25.3 ± 2.51 lbf·ft]
3	Plug	34.3± 3.4 N·m (3.5 ± 0.35 kgf·m) [25.3 ± 2.51 lbf·ft]
4	Plug	1.5 ± 0.1 N·m (0.15 ± 0.01 kgf·m) [1.106 ± 0.074 lbf·ft]
5	Plug	14.7 ± 1.5 N·m (1.50 ± 0.15 kgf·m) [10.842 ± 1.106 lbf·ft]
6	Mounting bolt	15.7 ± 1.6 N·m (1.60 ± 0.16 kgf·m) [11.580 ± 1.180 lbf·ft]
7	Mounting bolt	15.7 ± 1.6 N·m (1.60 ± 0.16 kgf·m) [11.580 ± 1.180 lbf·ft]
8	Mounting bolt	15.7 ± 1.6 N·m (1.60 ± 0.16 kgf·m) [11.580 ± 1.180 lbf·ft]
9	Mounting bolt	15.7 ± 1.6 N·m (1.60 ± 0.16 kgf·m) [11.580 ± 1.180 lbf·ft]

23. Assembling Tilt Cylinder

23.1 Assembly Sequence

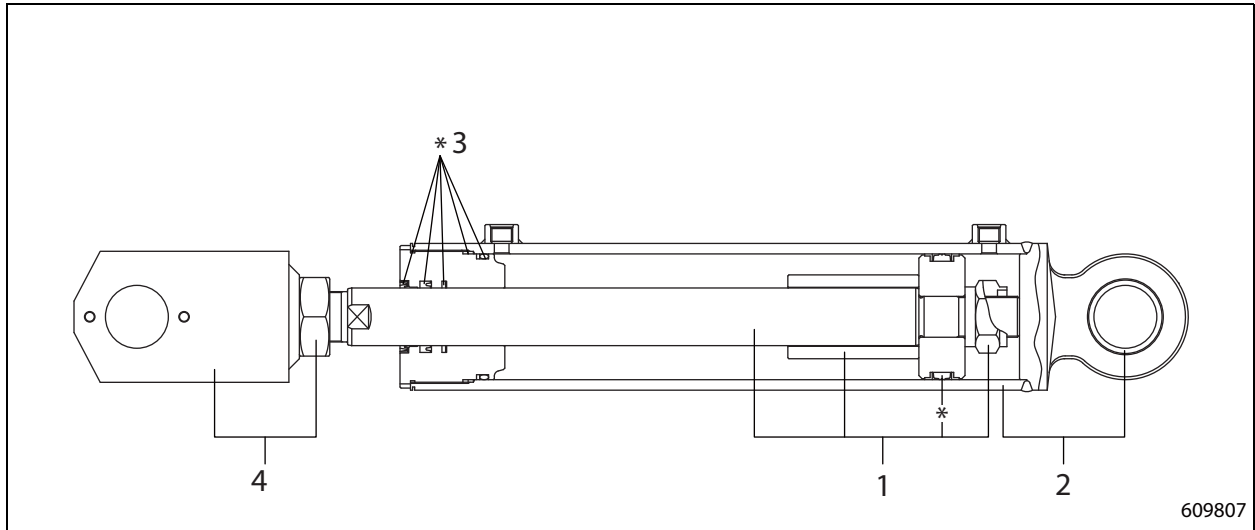

- | | |
|---|--|
| <ol style="list-style-type: none"> 1. Piston rod, Collar, Piston, Piston Seal*, Self-locking nut 2. Cylinder, Bushing | <ol style="list-style-type: none"> 3. Guide bushing, Rod packing, Buffer ring, Dust seal, Backup ring, O-ring 4. Socket, Nut |
|---|--|

Note: Parts marked with * are seal kit parts.

23.2 Suggestions for Assembly

- (1) Replace the * marked seal kit parts with new ones when assembling.
- (2) Thoroughly clean all parts before assembly making sure they are completely free from dirt or dust.
- (3) Apply a coat of oil on inside surfaces of piston seals, O-rings, packings, dust seals, and cylinder tube before assembly.
- (4) When holding the cylinder's outer circumference in a vise, be careful not to over-tighten and distort the cylinder tube.
- (5) To install piston seals, lightly compress and release the piston seal 5 to 6 times by hand to make it soft.
- (6) Secure the piston rod in a vise, taking care not to cause damage to it, and apply a thin coat of hydraulic oil on the piston seal. Fit half of the seal into the piston groove, and then press the other half into the groove.
- (7) Pay attention to the orientation of packings and dust seals when installing them on guide bushings.

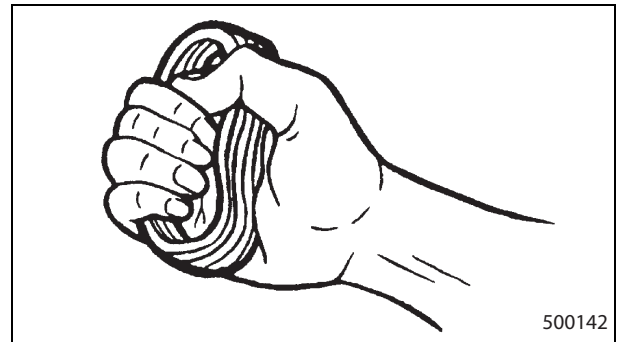

500142

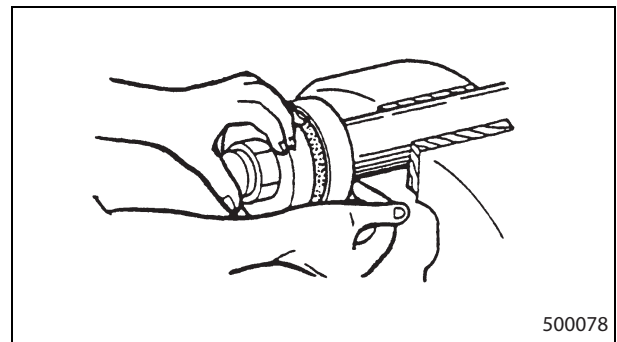

500078

27.7 Tilt Cylinder

Ref.	Item		FD100NM1 FD100NM1S	FD120NM1 FD120NM1S	FD135NM1 FD135NM1S	FD150ANM1 FD150ANM1S
1	Cylinder inside diameter		Standard	120 mm (4.72 in.)		130 mm (5.12 in.)
			Limit	120.12 mm (4.7291 in.)		130.12 mm (5.1228 in.)
2	Guide bushing	Outside diameter of piston rod	Standard	55 mm (2.17 in.)		
		Clearance between rod and guide bushing	Standard	0.1 mm (0.004 in.)		
			Limit	0.2 mm (0.008 in.)		
3	Inside diameter of bushing (under press-fit condition)		Standard	60 ^{+0.100} _{+0.070} mm (2.36 ^{+0.0039} _{+0.0028} in.)		
			Limit	60.6 mm (2.386 in.)		
4	Guide bushing		Tightening torque	637.7 ± 64 N·m (65.03 ± 6.5 kgf·m) [470.343 ± 47.20 lbf·ft]	696.5 ± 69 N·m (71.02 ± 7.0 kgf·m) [513.712 ± 50.89 lbf·ft]	
5	Socket nut		Tightening torque	1334 to 1468 N·m (136.0 to 149.7 kgf·m) [983.91 to 1082.74 lbf·ft]	1618 to 1780 N·m (165.0 to 181.5 kgf·m) [1193.38 to 1312.86 lbf·ft]	
6	Outside diameter of tilt socket pin		Standard	60 ^{+0.010} _{-0.029} mm (2.36 ^{+0.0004} _{-0.0011} in.)		
			Limit	59 mm (2.32 in.)		
7	Tilt socket pin mounting bolt		Tightening torque	33 N·m (3.4 kgf·m) [24.34 lbf·ft]		
8	Piston rod deflection (1/2 TIR)		Standard	1.0 mm (0.039 in.)		
9	Self-locking nut		Tightening torque	1471 ⁺¹⁴⁷ ₀ N·m (150.0 ^{+15.0} ₀ kgf·m) [1084.95 ^{+108.42} ₀ lbf·ft]	1765 ⁺¹⁷⁷ ₀ N·m (180.0 ^{+18.0} ₀ kgf·m) [1301.80 ^{+130.55} ₀ lbf·ft]	

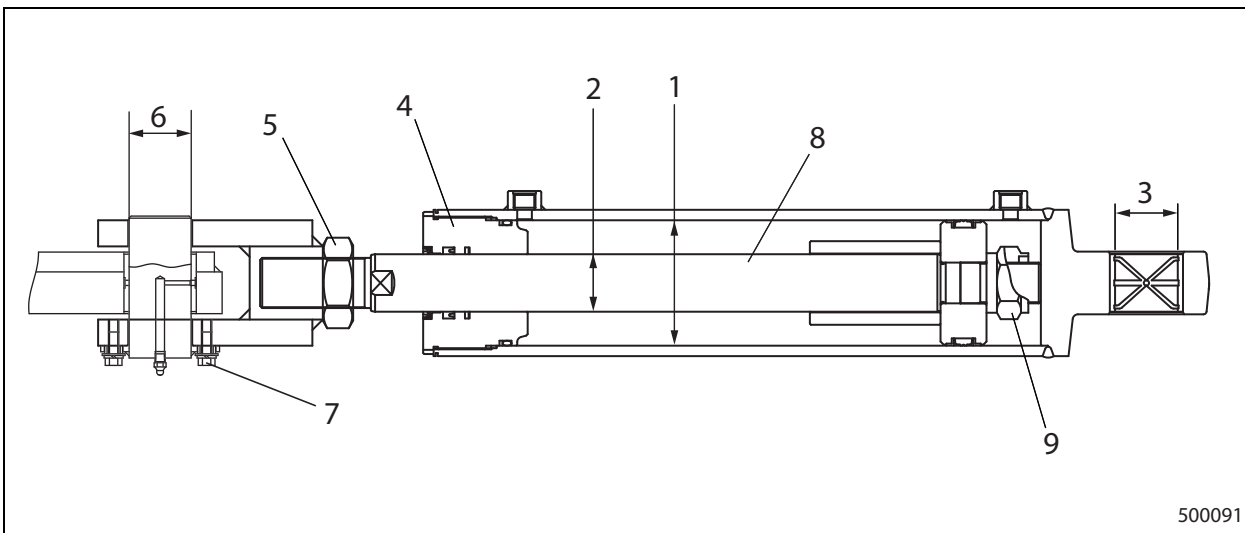

Mast support

- (1) Apply grease on the inner surface of the caps and the mast support groove.
- (2) Place the chamfered sides of the mast support bushing and the cap to face the center of forklift truck, then assemble.
For easier greasing, place wood blocks under the mast and tilt the mast forward so that the mast is off the ground.

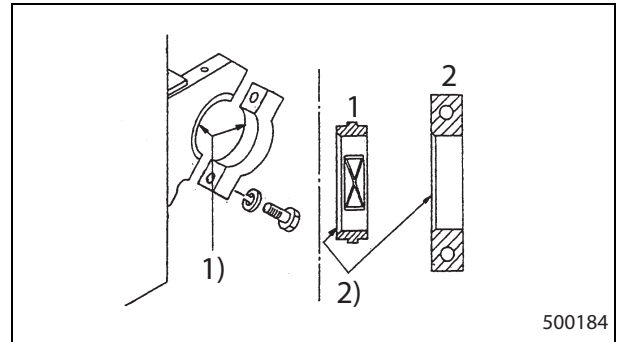

- | | |
|-------------|----------------------|
| 1. Bushing | 1) Applying grease |
| 2. Mast cap | 2) Bigger chamfering |

500184

Bolt tightening torque

490 ± 49 N·m (50.0 ± 5.0 kgf·m) [361.41 ± 36.14 lbf·ft]

Caution when assembling chain anchor kit

Never install the center plate in the position of link plate.

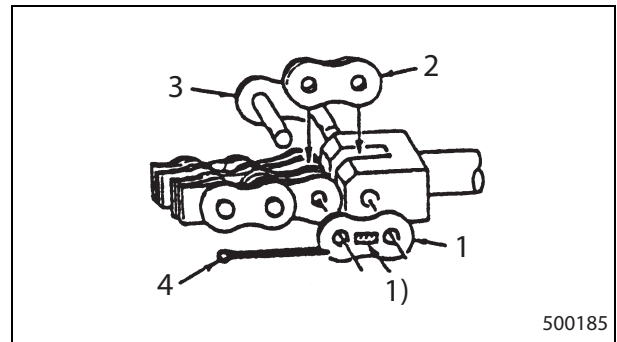

- | | |
|---|------------------|
| 1. Link plate
(Marking on the face) | 3. Link |
| 2. Center plate
(No marking on the face) | 4. Split pin |
| | 1) Engraved mark |

500185

4SFS135AM, 4SF135AM, 5FS160AM, SF160AM

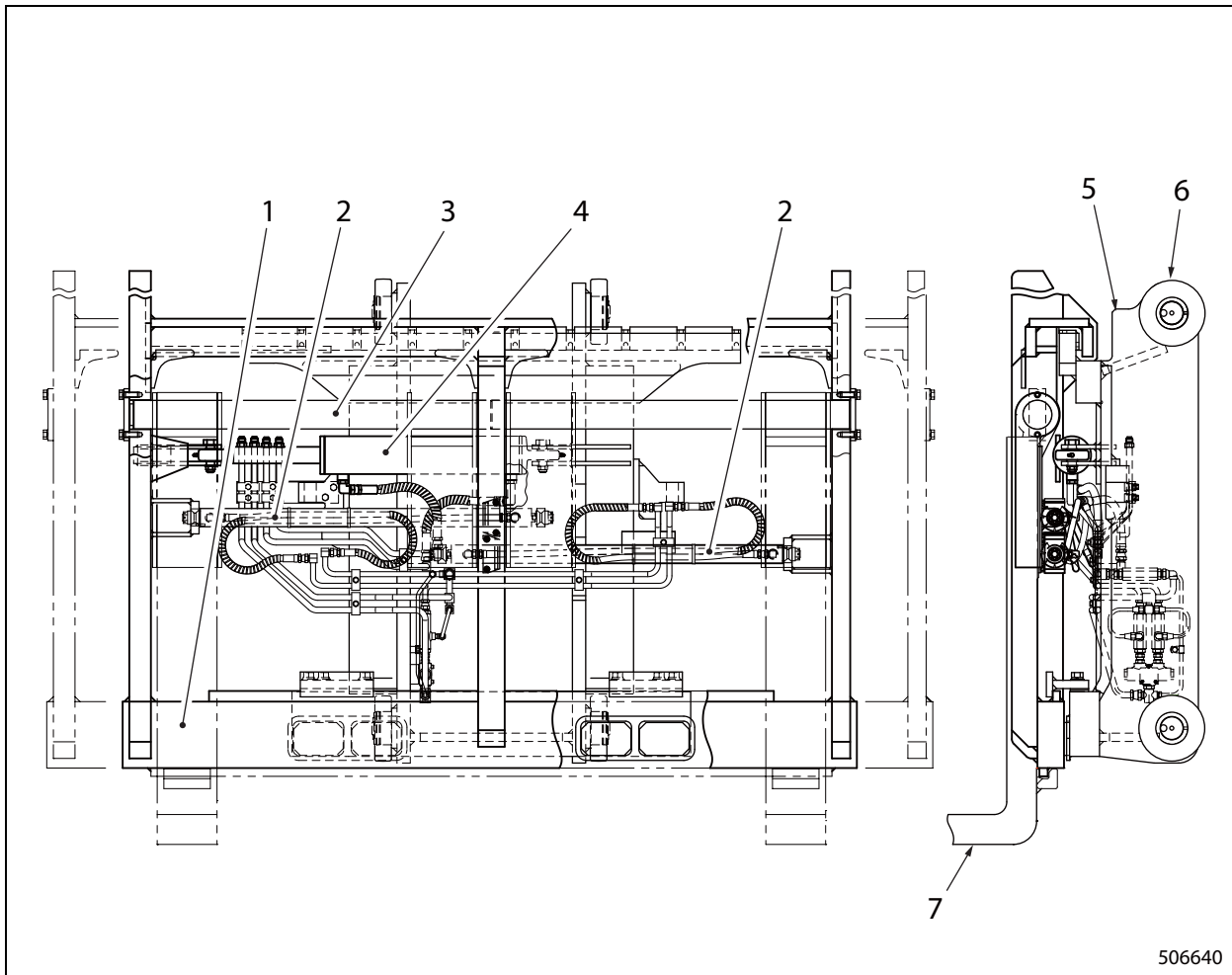

506640

- | | |
|-----------------------------|-----------------|
| 1. Carriage | 5. Lift bracket |
| 2. Fork positioner cylinder | 6. Main roller |
| 3. Fork guide bar | 7. Fork |
| 4. Side shifter cylinder | |

A hydraulic cylinder is attached to the carriage in front of the lift bracket. The carriage moves from side to side by extension and contraction of the cylinder.

It is difficult to bring a large forklift truck in the proper position for loading and unloading operation. When the forklift truck is equipped with the side shifter, efficiency of loading and unloading operations can be improved because you do not have to move the forklift truck, as the carriage with loads moves from side to side.

7.2 Suggestions for Disassembly

Removing guide bushing

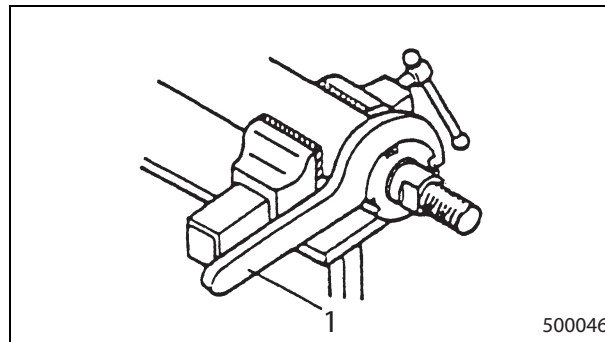

- (1) Release the caulking of the cylinder.
- (2) Wrap the cylinder with a rag, and clamp it in a vise. Using the hook wrench, remove the guide bushing from the cylinder.



500046

1. Hook wrench

Special tool	Part number
Hook wrench	05312-20520

Nominal size mm	Pitch mm	Without spring washer								
		 500247			 500248			 500249		
		N-m	kgf-m	lbf-ft	N-m	kgf-m	lbf-ft	N-m	kgf-m	lbf-ft
10	1.5	39.2	4.00	28.91	51.0	5.20	37.62	79.4	8.10	58.56
12	1.75	69.6	7.10	51.33	90.2	9.20	66.53	135.3	13.80	99.79
14	2	112.8	11.50	83.20	146.1	14.90	107.76	215.7	21.99	159.09
16	2	172.6	17.60	127.30	224.6	22.90	165.65	323.6	33.00	238.67
18	2.5	239.3	24.40	176.50	311.9	31.80	230.04	451.1	46.00	332.71
20	2.5	336.4	34.30	248.11	437.4	44.60	322.60	630.6	64.30	465.10
22	2.5	392.3	40.00	289.34	587.4	59.90	433.24	842.4	85.90	621.31
24	3	578.6	59.00	426.75	753.2	76.80	555.52	1088.5	110.99	802.82
27	3	852.2	86.90	628.54	1108.2	113.00	817.35	1588.7	162.00	1171.75
30	3.5	1140.5	116.30	841.18	1481.8	151.10	1092.90	2168.3	221.10	1599.23
33	3.5	1563.2	159.40	1152.94	2031.9	207.19	1498.63	2915.5	297.29	2150.33
36	4	1972.1	201.10	1454.52	2564.4	261.49	1891.37	3765.8	384.00	2777.47
39	4	2610.5	266.19	1925.37	3393.1	345.99	2502.58	4845.5	494.10	3573.80
42	4.5	3241.1	330.49	2390.47	4212.9	429.59	3107.22	6044.8	616.39	4458.34

Special symbols

The following symbols are used when the representation by general symbols is difficult.

This diagram shows that No. 1 and No. 3 terminals are connected when the switch position is placed in N position.

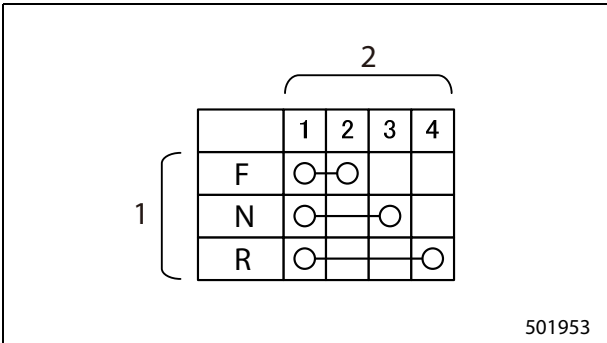

1. Switch position

2. Terminal

2.2 Sheet Symbol

A sheet symbol is provided in each circuit diagram sheet so that the relationship between diagrams can be clarified. The sheet symbol consists of "SH" and two digit numbers, for example, "SH-01" or "SH-02".

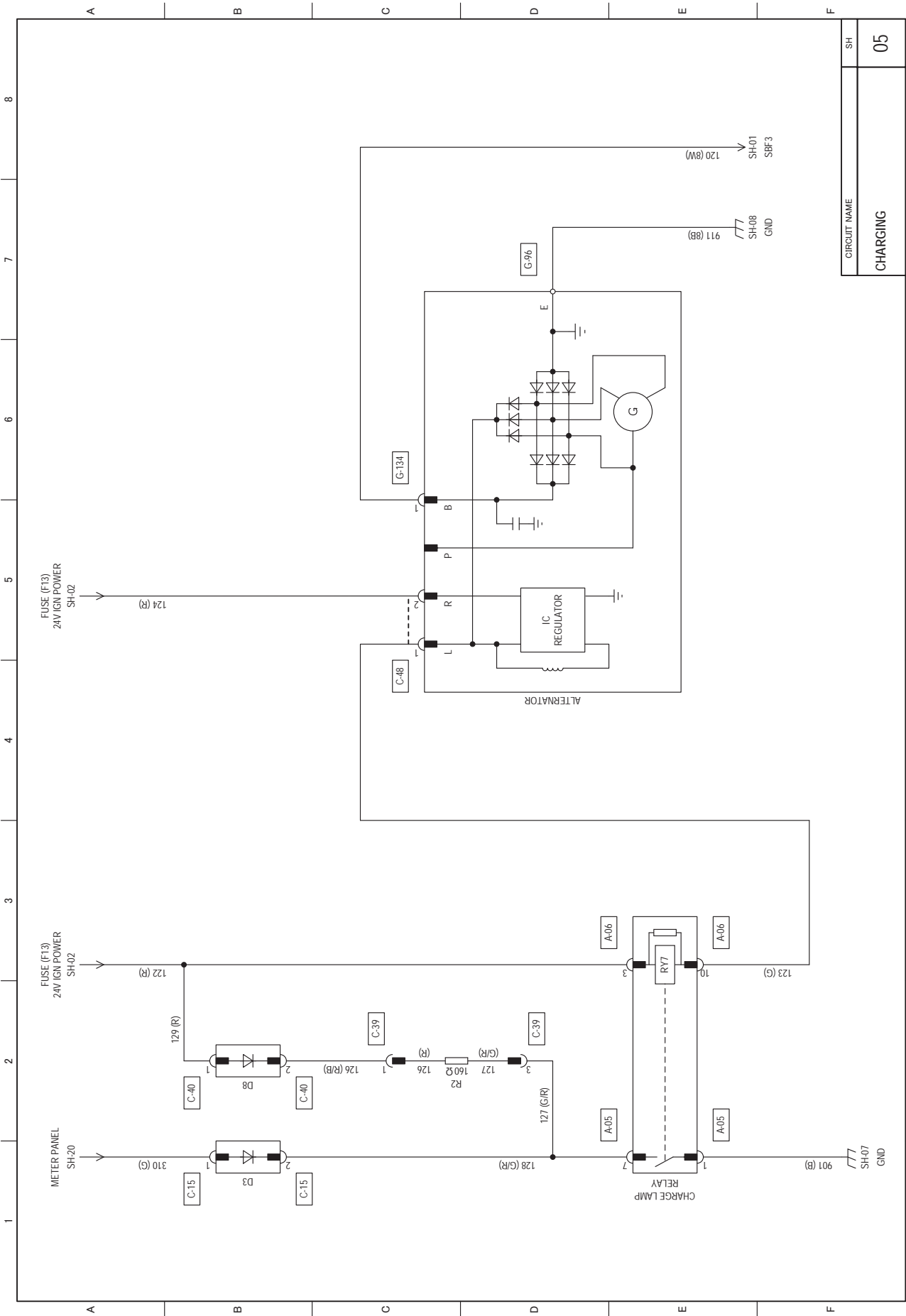

CIRCUIT NAME	SH
	05
CHARGING	

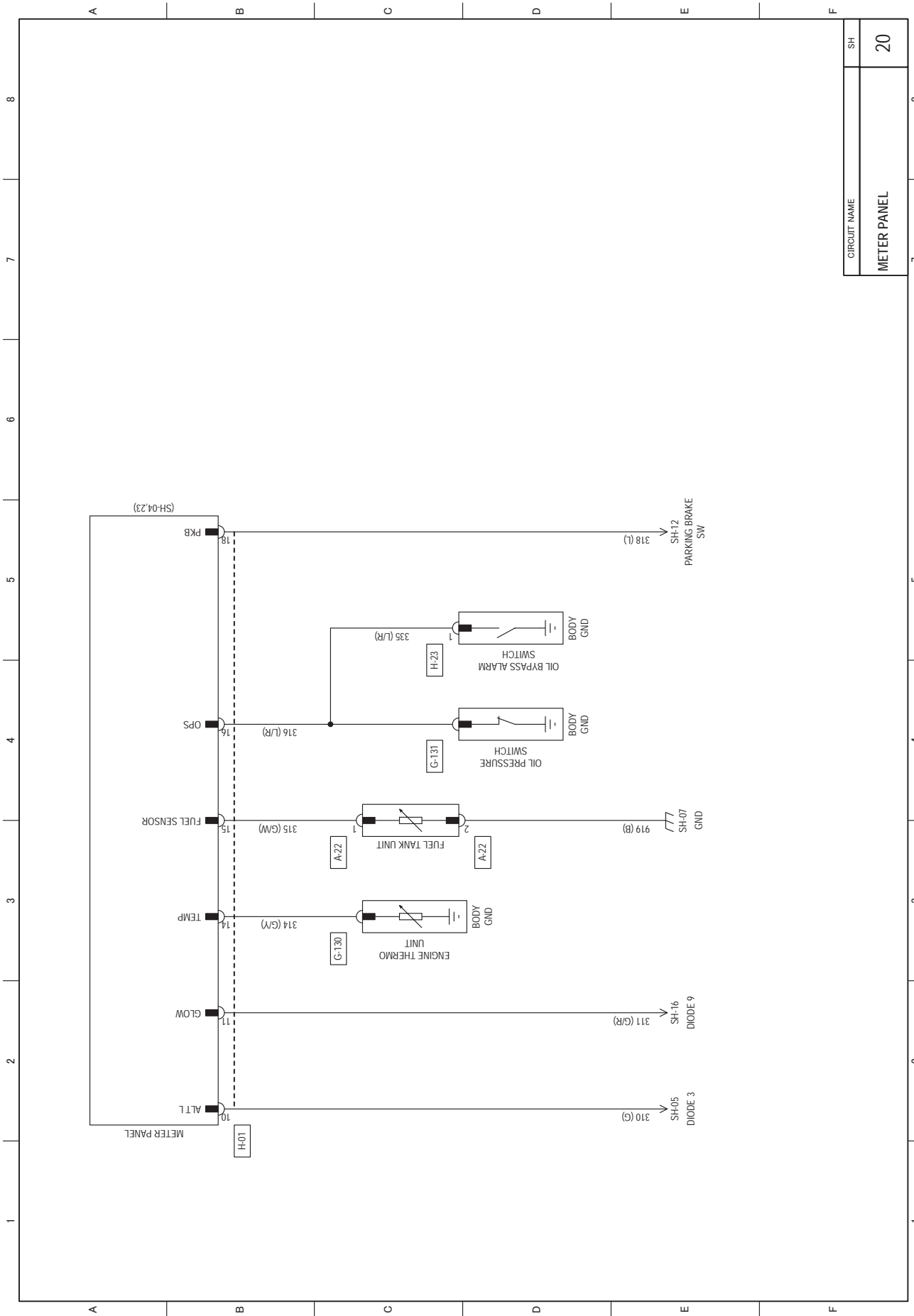

CIRCUIT NAME	SH
METER PANEL	20



Service Manual

Chassis & Mast

LC/FC

FD100NM1	AF15E-20011-39999
FD120NM1	AF15E-20011-39999
FD135NM1	AF15E-20011-39999
FD150ANM1	AF24C-20011-39999

4.7	Assembling Tilt Lock Lever	10-11
5.	Disassembling Steering Valve	10-12
5.1	Disassembly Sequence	10-12
5.2	Suggestions for Disassembling Steering Valve	10-13
5.3	Inspecting Steering Valve after Disassembly	10-16
6.	Assembling Steering Valve	10-17
6.1	Preparation	10-17
6.2	Assembly Sequence	10-17
6.3	Suggestions for Assembly	10-18
7.	Troubleshooting	10-23
8.	Service Data	10-24

Chapter 11 HYDRAULIC SYSTEM

1.	Specifications	11-1
2.	Structure	11-2
2.1	Hydraulic Line	11-2
2.2	Hydraulic Tank	11-3
2.3	Gear Pump	11-4
2.4	Priority Valve	11-5
2.5	Control Valve	11-6
2.6	Lift and Tilt Cylinders	11-8
2.7	Flow Regulator Valve	11-9
3.	Removing Control Valve	11-10
3.1	Preparation	11-10
3.2	Removal Sequence	11-10
3.3	Suggestions for Removal	11-11
4.	Removing Lift Cylinders	11-12
4.1	Suggestions for Removal	11-13
5.	Installing Lift Cylinders	11-13
5.1	Suggestions for Installation	11-13
6.	Removing Tilt Cylinders	11-14
6.1	Preparation	11-14
6.2	Removal Sequence	11-14
6.3	Suggestions for Removal	11-15
7.	Removing Gear Pump	11-16
8.	Disassembling Gear Pump	11-17
8.1	Preparation	11-17
8.2	Disassembly Sequence	11-17
8.3	Suggestions for Disassembly	11-18
9.	Inspecting and Repairing Gear Pump	11-19
10.	Assembling Gear Pump	11-21
10.1	Preparation	11-21
10.2	Suggestions for Assembly	11-21
11.	Installing Gear Pump	11-22
12.	Disassembling Priority Valve	11-23

4. Inspecting and Adjusting Radiator and Intercooler

4.1 Intercooler

- Replace the radiator mount rubber if it is hardened and has no elasticity.
- If such obstacles as bugs and dust are deposited on the fins, wash them off by spraying pressurized water in the reverse of air flow direction. Pay attention not to damage the fins.

⚠ CAUTION

Wear goggles for your safety.

- Replace the intercooler if corrosion or rust is significant, or the fins cannot be repaired.
- Check the intercooler hoses for bulges and damage at the hose clamps. If a hose is defective, replace the hose.

4.2 Inspecting Fan Belt

Adjustment of fan belt tension

- (1) Verify the smooth rotation of fan after removing the fan belt. If the bearing makes noise, replace the bearing.
- (2) Install the fan belt and push the belt center position between pulleys. Adjust the deflection to the specified value at the specified push load with the tension pulley. Tighten the tension pulley lock bolt firmly after the adjustment.

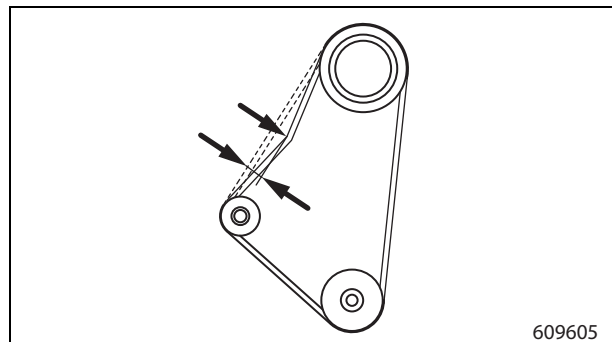

Item	Standard value
Push load	98.1 N (10 kgf) [22.05 lbf]
Belt deflection	24 to 26 mm (0.94 to 1.02 in.)

4.3 Radiator

Radiator

Check the core for dirt, dust, and other foreign objects. If foreign objects are deposited on the core surface, wash them off by spraying pressurized water in the reverse of air flow direction.

⚠ CAUTION

Be careful not to damage the water pipe while cleaning.

Radiator mount rubber (Rubber cushion)

Replace radiator mount rubber if it is hardened or not elastic.

Radiator hose (upper, lower)

Check the hoses for bulges and damage at the clamps. If a hose is defective, replace the hose.

Starter, Alternator, and Engine thermo unit

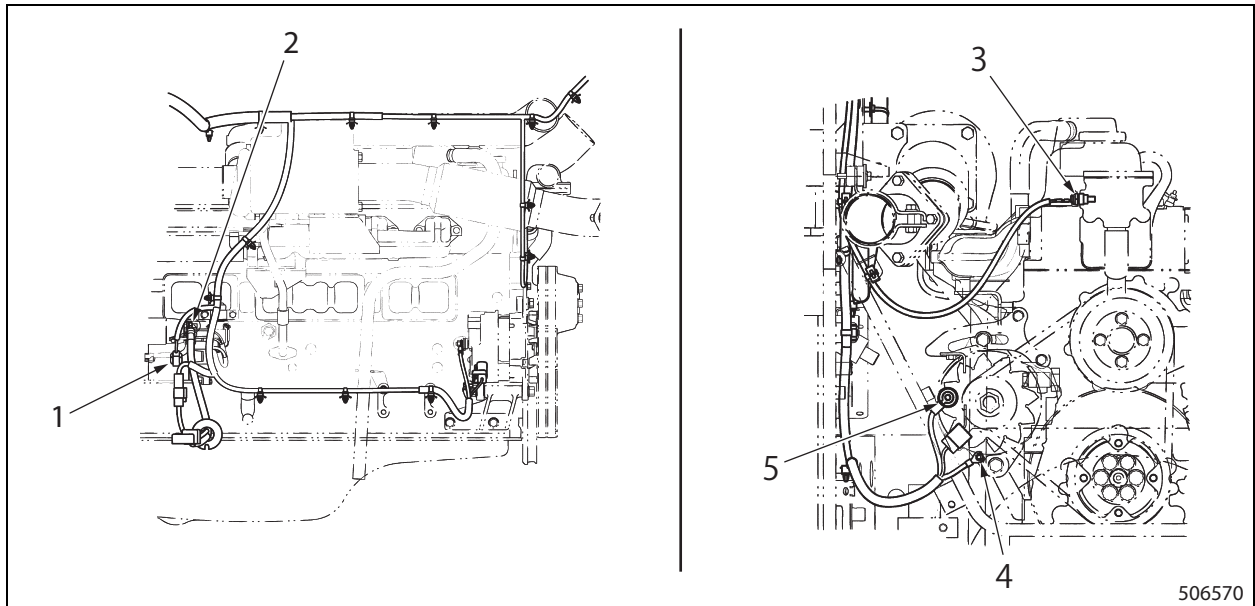

- 1. Starter
- 2. Starter B
tightening torque: $9.8 \begin{smallmatrix} +2 \\ 0 \end{smallmatrix}$ N-m ($1.0 \begin{smallmatrix} +0.20 \\ 0 \end{smallmatrix}$ kgf-m) [$7.23 \begin{smallmatrix} +1.48 \\ 0 \end{smallmatrix}$ lbf-ft]
- 3. Thermo switch, tightening torque: 19.6 to 27.4 N-m (2.00 to 2.79 kgf-m) [14.46 to 20.21 lbf-ft]
- 4. Alternator E, tightening torque: 4.0 to 6.0 N-m (0.41 to 0.61 kgf-m) [2.95 to 4.43 lbf-ft]
- 5. Alternator B, tightening torque: 10.0 to 15.0 N-m (1.02 to 1.53 kgf-m) [7.38 to 11.08 lbf-ft]

Note: Wrap the threaded end with seal tape and coated bond (ThreeBond #1305)

3.7 Horn

Apply the specified voltage to both terminals of the horn, **T1** and **T2**, and check if the horn activates.

If the horn does not sound or sounds strange, replace the horn.

Operating voltage: DC24V

Note:

- (1) Orient the horn as shown when installing.
- (2) Horn terminals **T1** and **T2** do not have a polarity.

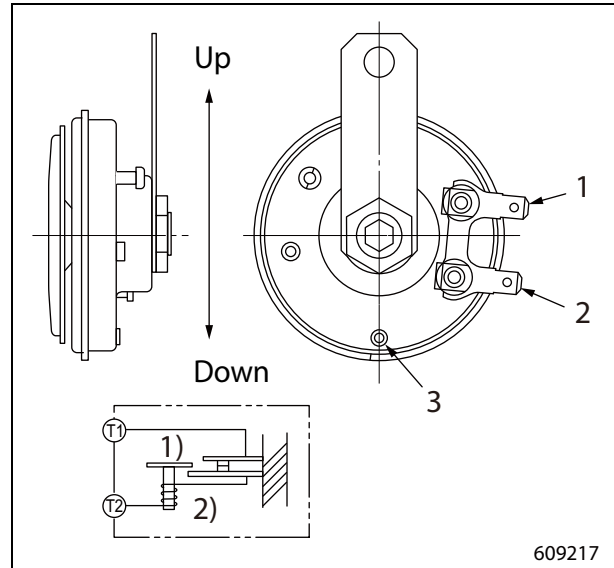

1. T1
2. T2
3. Air hole

- 1) Contact
- 2) Coil

Insulation resistance	3 M ohm or more (with 500V insulation resistance tester)
-----------------------	---

Speed meter display

This display will show real-time forklift truck speed.

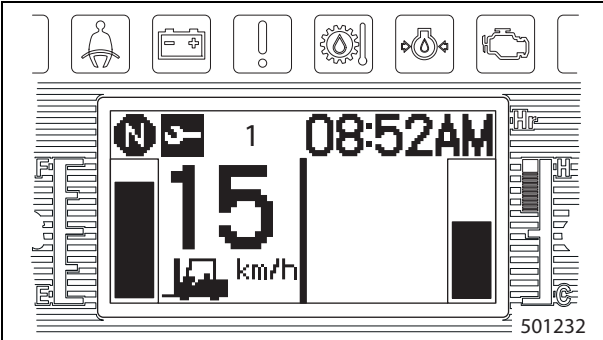





1. Speed meter display

Actual speed	Display
0.1 to 1.0 km/h (0.06 to 0.62 mph)	1 km/h (0.6 mph)
1.1 to 2.0 km/h (0.68 to 1.24 mph)	2 km/h (1.2 mph)
· · · ·	· · · ·
29.1 to 30.0 km/h (18.04 to 18.60 mph)	30 km/h (18.6 mph)

A rounded up speed meter reading will be displayed.

5.6 Warning Symbols

The following warning symbols are displayed in the main area:

Symbol	Name	Indicated condition	Applied model
	Fuel filter water draining warning symbol	The symbol glows when the water in the fuel filter needs to be drained	All models (standard)
	Low coolant level warning symbol	Coolant is low	All models (standard)
	Clogged air cleaner element warning symbol	Air cleaner is clogged	All models (option)
	Low fuel level warning symbol	Fuel level is low (E level)	All models (standard)

1.3 Controller External View

VCM

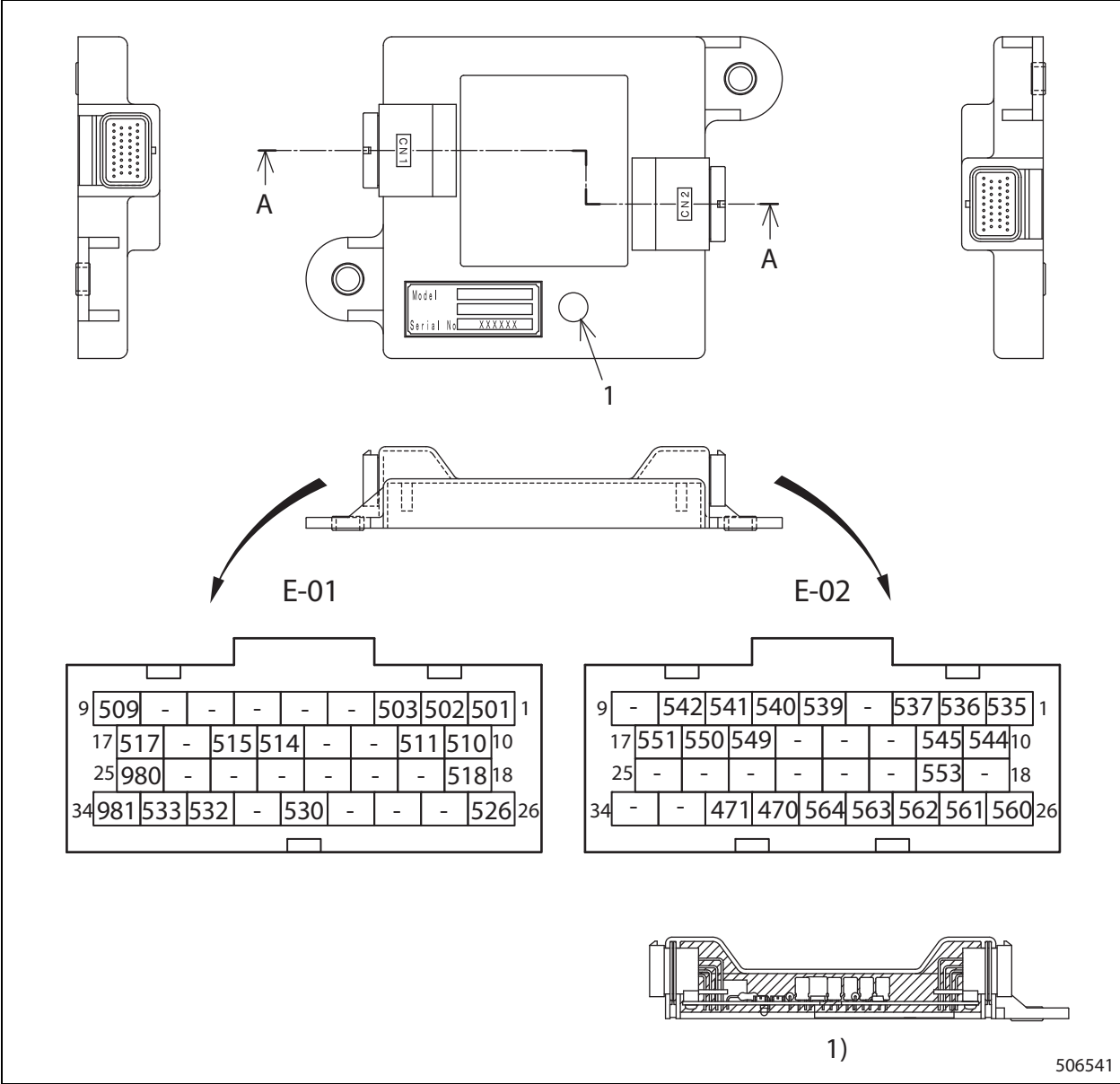

1. Pink sticker (for identification)

1) Section A-A

506541

CLICK HERE TO **DOWNLOAD** THE COMPLETE MANUAL

- Thank you very much for reading the preview of the manual.
- You can download the complete manual from: www.heydownloads.com by clicking the link below



- Please note: If there is no response to CLICKING the link, please download this PDF first and then click on it.

CLICK HERE TO **DOWNLOAD** THE COMPLETE MANUAL

3. Diagnostic Code List

Code	Description
F01	VCM Memory Check Warning
F02	VCM Battery Voltage Warning
F03	VCM Communication Warning
F07	MP Communication Warning
F10	Lift Lever Neutral Warning
F11	Tilt Lever Neutral Warning
F12	Attachment 1 Lever Neutral Warning
F13	Attachment 2 Lever Neutral Warning
F14	Attachment 3 Lever Neutral Warning
F16	Direction Lever Warning
F17	Vehicle Speed Warning
F20	Lift Lever Warning
F22	Tilt Lever Warning
F24	Attachment 1 Lever Warning
F26	Attachment 2 Lever Warning
F28	Attachment 3 Lever Warning
F29	Joystick Lever Warning
F31	VCM Sensor Voltage Warning
F34	Vehicle Speed Sensor Warning
F41	Output Unit Warning
F44	Output Unit PWM Voltage Warning
F45	Output Unit Communication Warning
F46	Input Unit Warning
F49	Input Unit Communication Warning
F50	Lift Up Solenoid Warning
F52	Lift Down Solenoid Warning

Code	Description
F54	Lift Solenoid Leak
F55	Tilt Forward Solenoid Warning
F57	Tilt Backward Solenoid Warning
F59	Tilt Solenoid Leak
F60	Attachment 1A Solenoid Warning
F62	Attachment 1B Solenoid Warning
F64	Attachment 1 Solenoid Leak
F65	Attachment 2A Solenoid Warning
F67	Attachment 2B Solenoid Warning
F69	Attachment 2 Solenoid Warning
F70	Attachment 3A Solenoid Warning
F72	Attachment 3B Solenoid Warning
F73	Hour Meter Gap Warning
F74	Attachment 3 Solenoid Leak
F75	Unload Solenoid Warning
F79	Unload Solenoid Leak
F85	Transmission Forward Solenoid Warning
F87	Transmission Backward Solenoid Warning
F89	Transmission Solenoid Leak
F93	VCM Speed Change Solenoid 1 Warning
F96	EAT Setting Warning
P03	VCM Communication Warning
P07	MP Communication Warning
P22	Shift Lever Warning Signal

4.9 Attachment 2 Lever Neutral Warning (F13)

Diagnostic code: F13	
Situation	"F13" blinks. All load handling operations disabled.
Possible cause	Load handling lever operated when turning ON key switch. Faulty attachment 2 lever, faulty input unit, or faulty harness.
How the code is triggered	Attachment 2 lever is not in NEUTRAL when turning ON key switch.
Recovery	Auto recovery when the attachment 2 lever is placed in NEUTRAL.
Action	Turns OFF all solenoid outputs of operating functions.

Checks

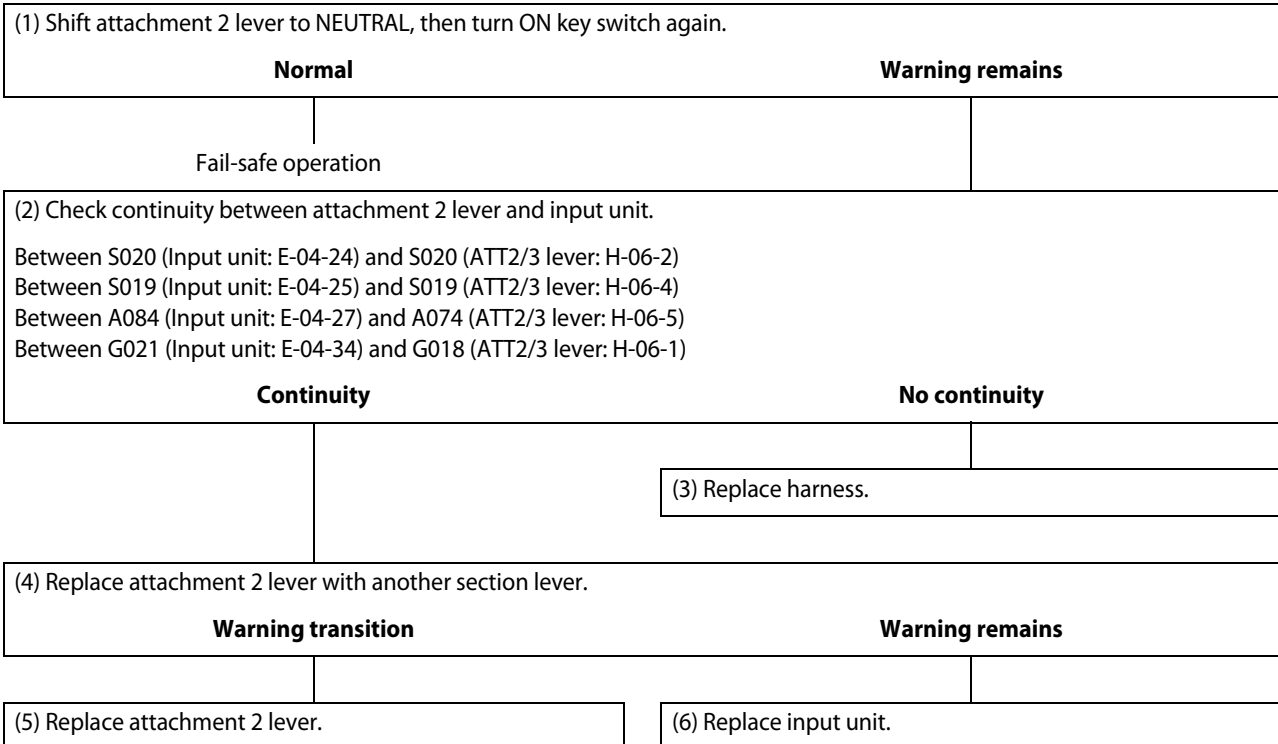

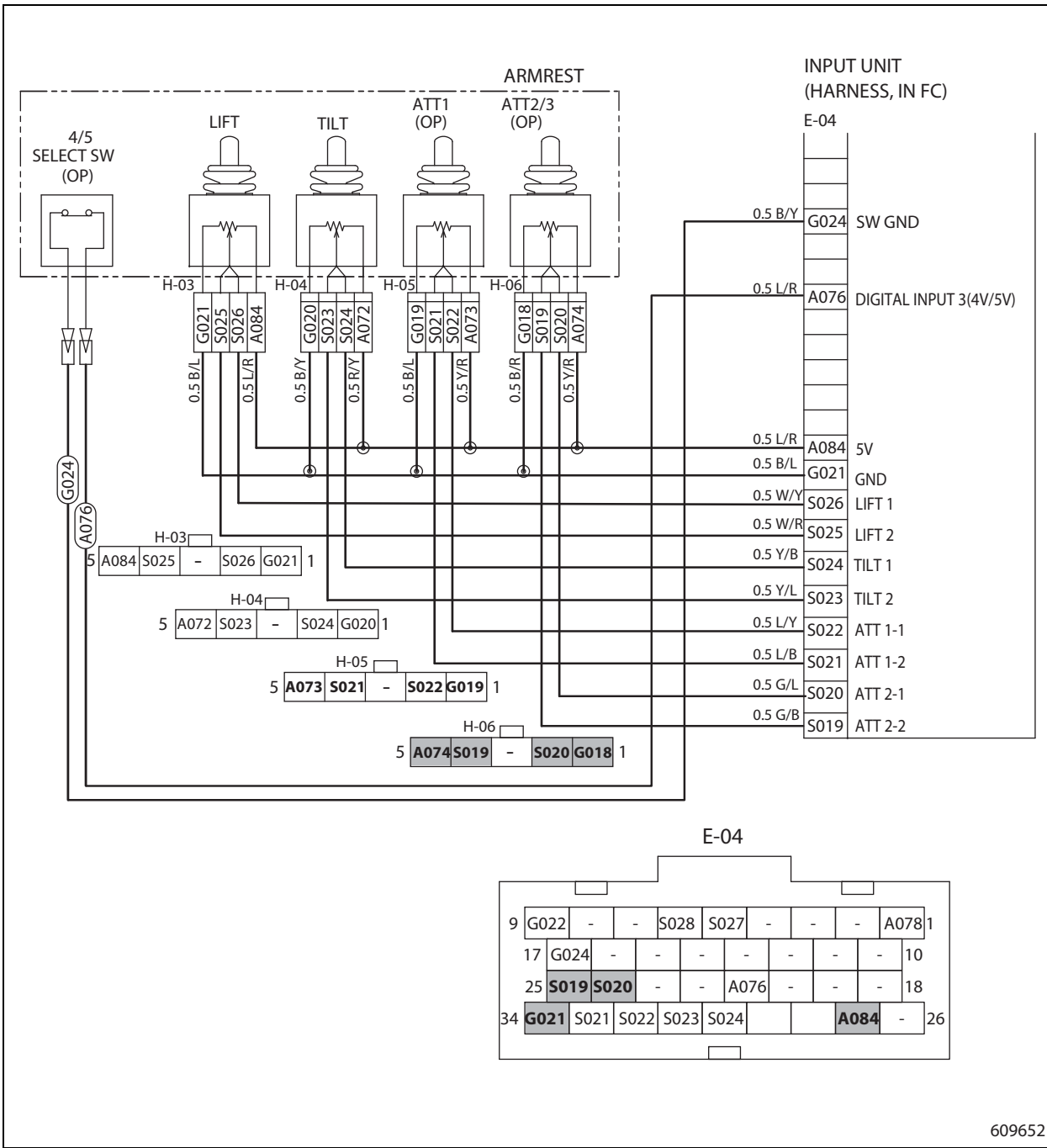

609652

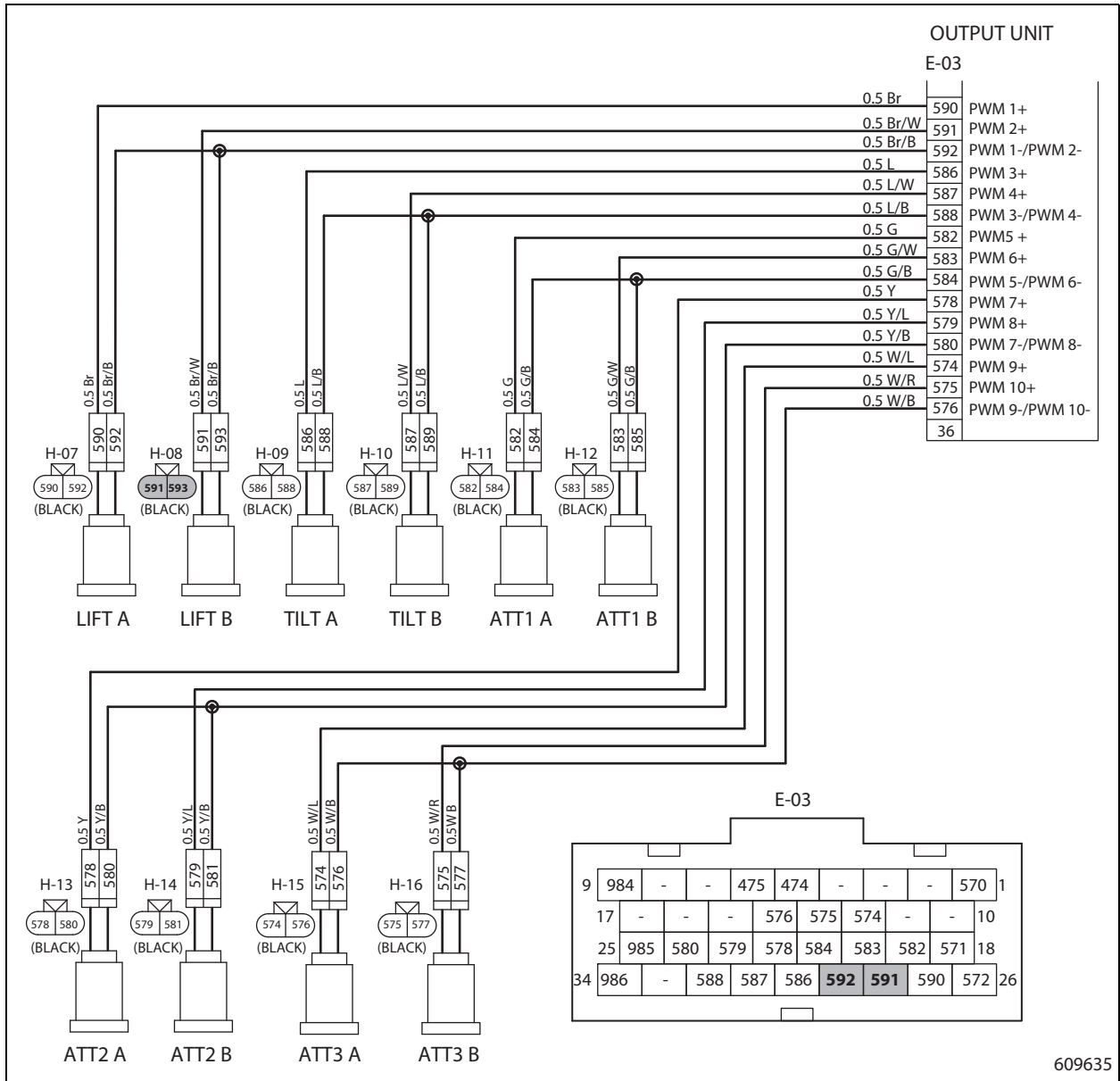

609635

4.33 Attachment 1 Solenoid Leak (F64)

Diagnostic code: F64	
Situation	"F64" blinks. All load handling operations disabled.
Possible cause	Faulty output unit, faulty operating function solenoid, or faulty harness.
How the code is triggered	Current is 0.18A or more when attachment 1 lever is not operated.
Recovery	Key OFF/ON.
Action	Turns OFF solenoid output of all models. Turns OFF unload solenoid.

Checks

(1) Check hydraulic operations when a diagnostic code occurs.

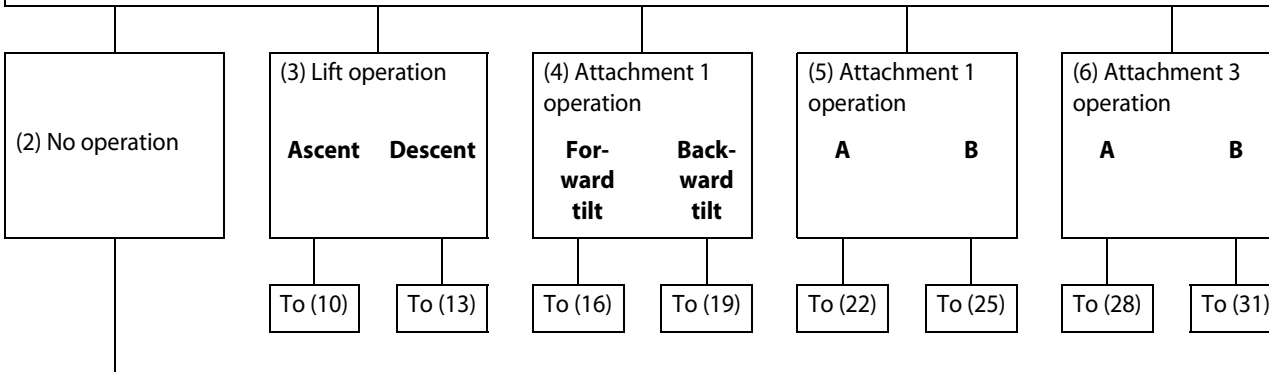

(7) Check resistance of the operating function solenoid causing the diagnostic code.

Normal (6.6Ω to 9.8Ω at 25°C (77°F))	Abnormal
---	-----------------



(10) Check continuity of attachment 1 section harness and lift section harness.
Between 590 (Output unit: 27) and 584 (Output unit: 21)

Continuity (Several 10Ω or less)	No continuity (Several M)
---	----------------------------------



(13) Check continuity of attachment 1 section harness and lift section harness.
Between 591 (Output unit: 28) and 584 (Output unit: 21)

Continuity (Several 10Ω or less)	No continuity (Several M)
---	----------------------------------



4.47 VCM Setting Warning (F96)

Diagnostic code: F96	
Situation	"F96" blinks. Speed change control disabled (gear fixed and will not move to another gear).
Possible cause	Faulty VCM, or faulty truck type setting data in VCM.
How the code is triggered	<p>1. When setting value of speed shift point is not in the following relations:</p> <ul style="list-style-type: none"> - 2-speed specification truck: (from 1st-speed to 2nd-speed) (from 2nd-speed to 1st-speed) - 3-speed specification truck: (from 2nd-speed to 3rd-speed) (from 3rd-speed to 2nd-speed) (from 1st-speed to 2nd-speed) (From 2nd-speed to 1st-speed) <p>2. When setting data for mode selection is in the following conditions:</p> <ul style="list-style-type: none"> - Mode selection value is out of setting range (0 to 3). - Mode selecting values are overlapped. - Both mode selector SWs are not set. <p>3. When setting data for speed change solenoid is in the following conditions:</p> <ul style="list-style-type: none"> - Speed change solenoid value is out of setting range (0 to 3). - Speed change solenoid values are overlapped. - Both speed change solenoids are not set.
Recovery	Auto recovery
Action	<p>Warning 1: Sets shift point to default value.</p> <p>Warning 2: Fixed to mode 1.</p> <p>Warning 3: Speed change solenoid 1 and 2 outputs are turned OFF.</p>

Checks

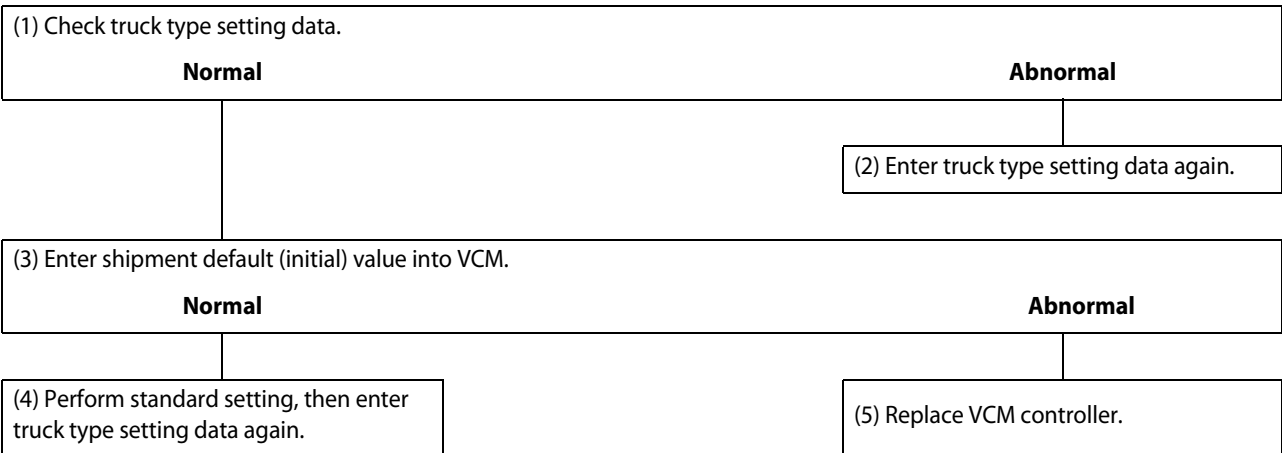

2. Structure

2.1 Torque Converter

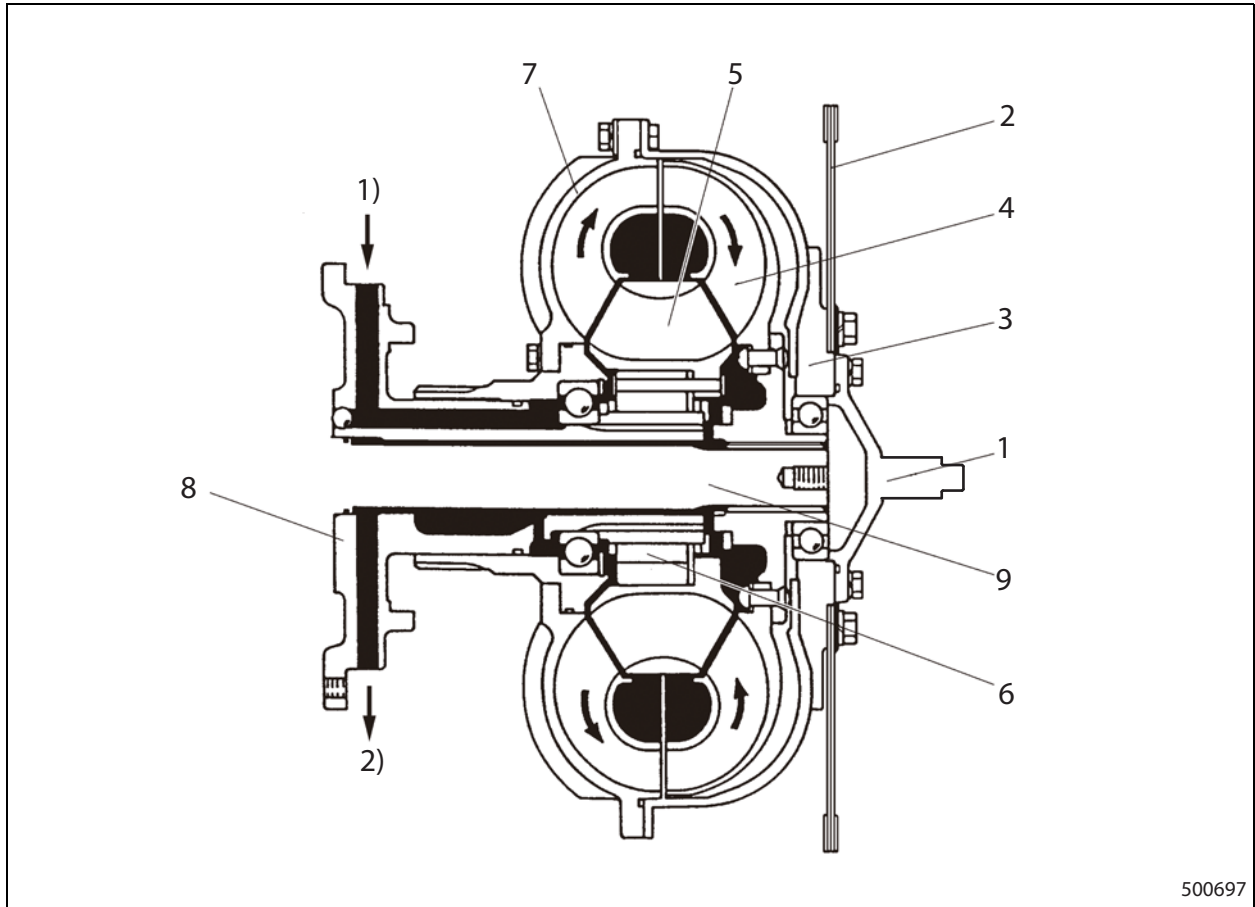

500697

- | | |
|---------------------|------------------|
| 1. Pilot boss | 7. Pump impeller |
| 2. Flexible plate | 8. Stator shaft |
| 3. Drive cover | 9. Input shaft |
| 4. Turbine assembly | 1) From oil pump |
| 5. Stator | 2) To oil cooler |
| 6. Freewheel | |

The pressurized oil in the torque converter flows to the outside of torque converter through the outlet port located inside the stator shaft, then to the transmission lubrication system through the oil cooler.

The oil flow created by the rotation of impeller rotates the turbine and input shaft.

The freewheel, which is a kind of one-way clutch, allows the stator to rotate freely and the torque converter to work as a fluid coupling when the rotational speed of the engine and the input shaft are almost the same. The freewheel improves the efficiency of the torque converter in a high speed operation.

Specification	Model
3-element, 1-stage, 2-phase	MI16

7. Assembling Torque Converter

7.1 Assembly Sequence

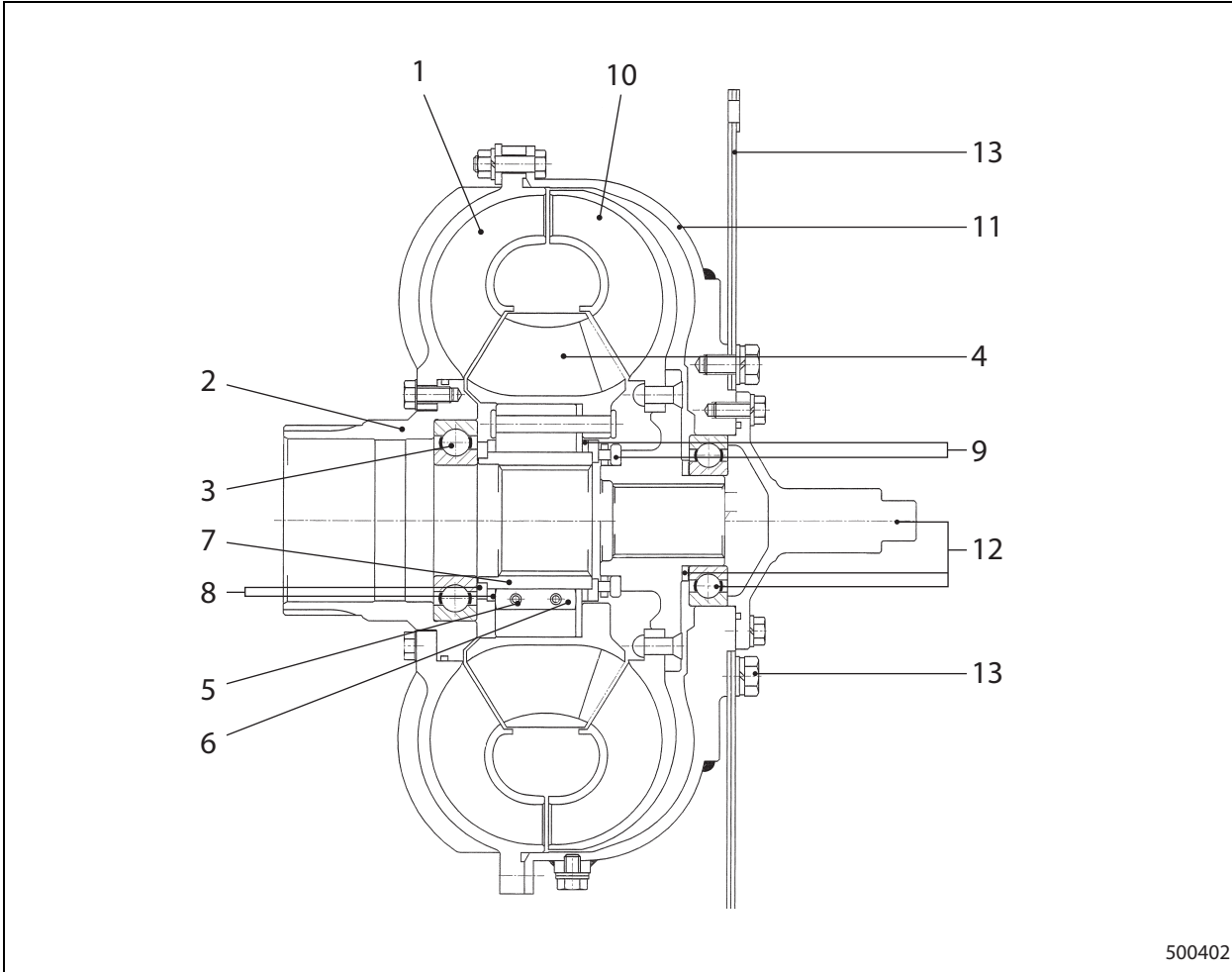

500402

- | | |
|--|---|
| 1. Pump impeller | 8. Thrust washer |
| 2. Pump boss, O-ring, Bolts, Toothed washers | 9. Thrust washer, Thrust bearing |
| 3. Ball bearing | 10. Turbine runner |
| 4. Stator assembly | 11. Drive cover, O-ring, Bolts, Washers |
| 5. Springs, Spring caps | 12. Thrust washer, Ball bearing, Pilot boss, O-ring, Bolts, Washers |
| 6. Rollers | 13. Flexible plates, Bolts, Plane washers, Spring washer |
| 7. Hub | |

Forward, reverse, and 1st/3rd speed clutch shafts

Check the shafts and make sure that they are free from the following defects:

- Wear and damage of seal rings and sliding surfaces
- Wear and damage of splines
- Clogged oil passages

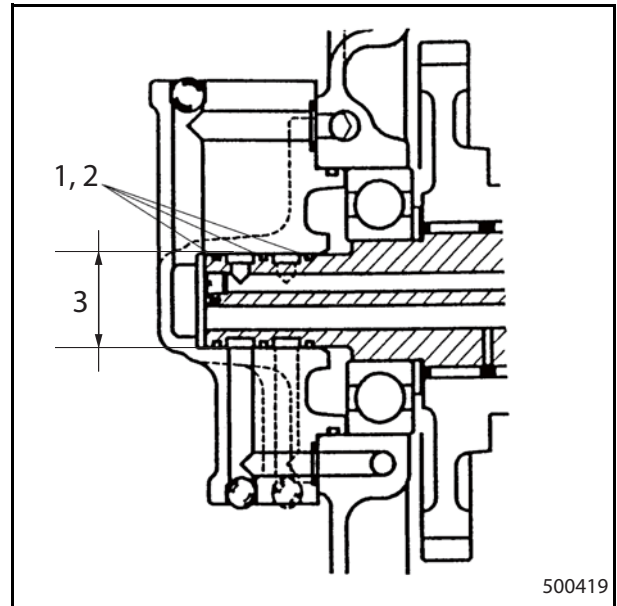

Ref.	Item	Standard	Limit
1	Seal ring width of clutch shafts	2.5 ± 0.05 mm (0.098 ± 0.0020 in.)	2.0 mm (0.079 in.)
2	Seal ring groove width of clutch shafts	2.5 ^{+0.2} / _{+0.1} mm (0.098 ^{+0.008} / _{+0.004} in.)	3.0 mm (0.118 in.)
3	Inside diameter of sealing contact faces in servo cases	35 mm ^{+0.025} / ₊₀ (1.38 ^{+0.001} / ₊₀ in.)	35.2 mm (1.386 in.)

Gears

Check the gears and make sure that they are free from the following defects:

- Wear and damage of teeth flank and splines
- Wear and damage of sliding surfaces of gear needle bearings

Assembling magnetic strainer

Disassemble and clean. Replace if heavily contaminated or broken.

Oil seals of transmission cover and torque converter housing

Replace with new ones.

17.2 Checking Oil Pressure

⚠ WARNING

Provide a barrier around the forklift truck to prevent the access of unauthorized people, as the front wheels rotates during the oil pressure measurement. Extend the gauge kit with the extending hose to secure the job safety.

Note: Adjust the pedals before measuring the oil pressure.

Checking main oil pressure

- (1) Connect a 2 MPa (20 kgf/cm²) [290 psi] oil pressure gauge to the main oil pressure outlet of the regulator valve.

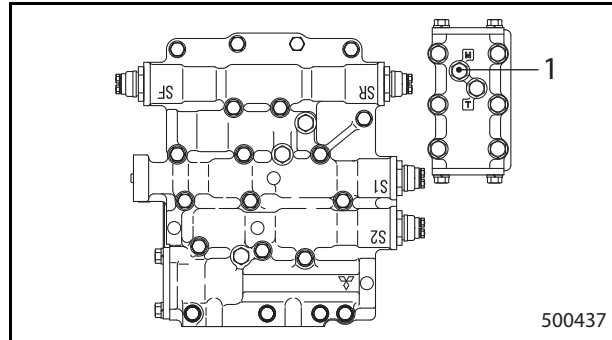

1. Main oil pressure outlet (M)
(G1/8)

Special tool name		Part number
Gauge kit (64309-17701)	Connector	64309-17733
	Hose	64309-17722
	Connector	64309-17731
	Gauge	64309-17713

- (2) After idling operation, turn the engine OFF and measure the oil level after 3 to 5 minutes to make sure that the oil level is within the specified range.
- (3) Warm up the engine to raise the transmission oil temperature.
- (4) Run the engine at an idling speed between 1000 and 1500 min⁻¹ and keep the speed.
- (5) Keep the condition above and measure the main oil pressure.

Item	Standard
Main oil pressure (Engine speed at 1500 ± 100 min ⁻¹)	1.26 to 1.38 MPa (12.85 to 14.07 kgf/cm ²) [182.7 to 200.15 psi]

Note: Measure the idling speed with the service tool.

19.8 Input Shaft, Forward, Reverse, and 1st/ 3rd Speed Clutch Shafts, and Servo Case

Ref.	Item		Value
1	Seal ring width of clutch shaft	Standard	2.5 ± 0.05 mm (0.098 \pm 0.0020 in.)
		Limit	2.0 mm (0.079 in.)
2	Seal ring groove width of clutch shaft	Standard	$2.5^{+0.2}_{+0.1}$ mm (0.098 $^{+0.008}_{+0.004}$ in.)
		Limit	3.0 mm (0.118 in.)
3	Inside diameter of servo case contacting with clutch shaft seal ring	Standard	$35^{+0.025}_0$ mm (1.38 $^{+0.001}_0$ in.)
		Limit	35.2 mm (1.386 in.)
4	Inside diameter of stator shaft contacting with input shaft seal ring	Standard	$35^{+0.025}_0$ mm (1.38 $^{+0.001}_0$ in.)
		Limit	35.2 mm (1.386 in.)
5	Seal ring width of each shaft clutch piston	Standard	2.5 ± 0.05 mm (0.098 \pm 0.0020 in.)
		Limit	2.0 mm (0.079 in.)
6	Seal ring groove width of each shaft clutch piston	Standard	$2.5^{+0.2}_{+0.1}$ mm (0.098 $^{+0.008}_{+0.004}$ in.)
		Limit	3.0 mm (0.118 in.)
7	Seal ring width	Standard	$2.4^0_{-0.1}$ mm (0.095 $^0_{-0.004}$ in.)
8	Seal ring groove width	Standard	$2.5^{+0.2}_{+0.1}$ mm (0.098 $^{+0.008}_{+0.004}$ in.)
9	Tightening torque of locknut	Standard	389 ± 38.9 N·m (39.7 \pm 3.97 kgf·m) [286.91 \pm 28.691 lbf·ft]

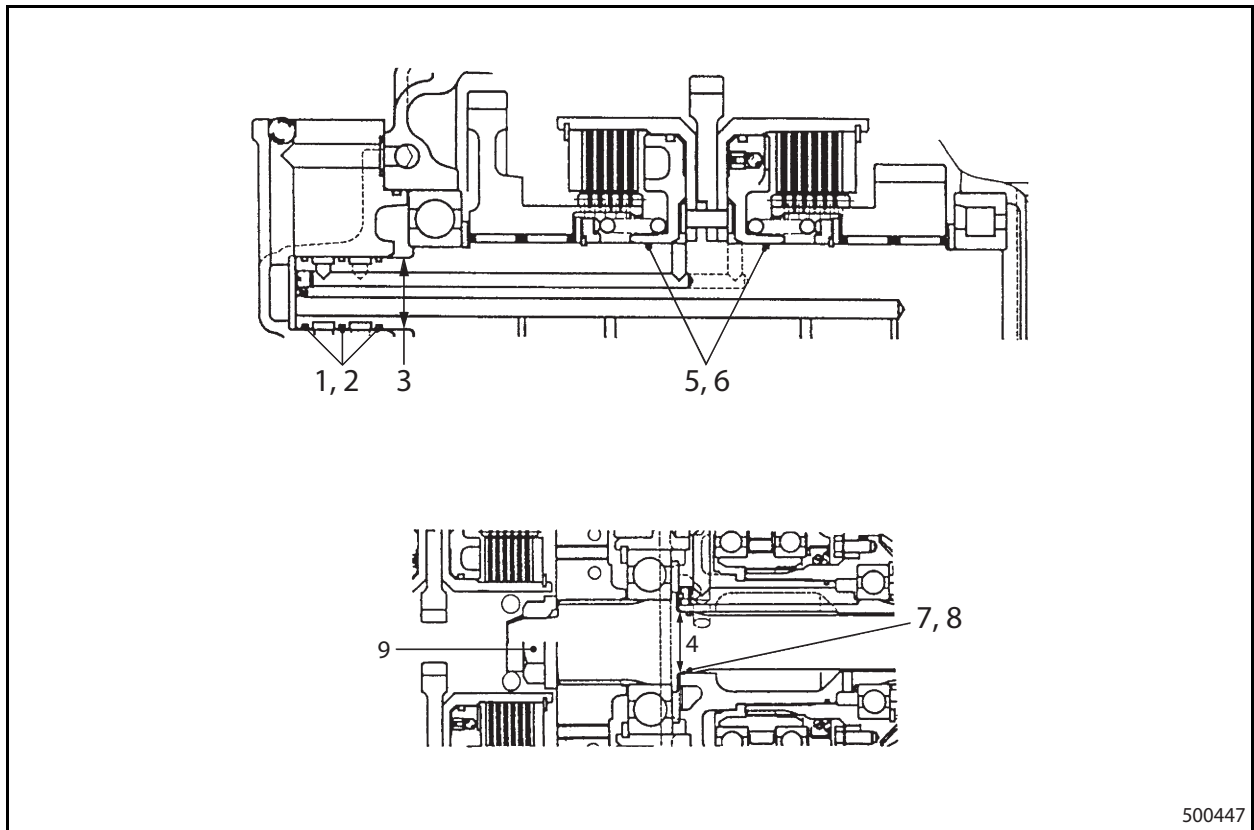

500447

5.3 Suggestions for Removal

Wheel brake pipes (right and left)

After the wheel brake pipes are disconnected, cover the openings of the wheel cylinder and pipes to prevent dirt from getting inside them.

Universal joint

(1) Temporarily fasten the universal joint to the transmission body with a rope, etc.

Note: If the universal joint comes off from the transmission body, the transmission oil will flow out.

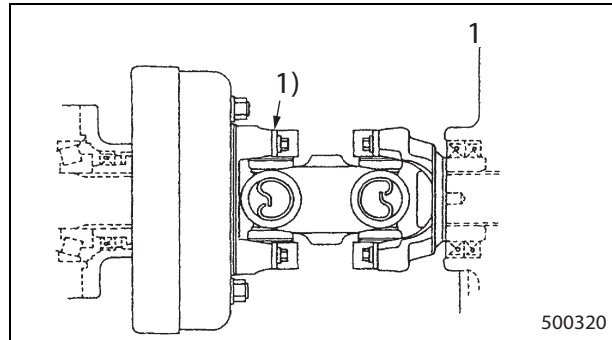

1. Transmission

1) Disconnect here.

(2) Disconnect the universal joint at the input flange side of the reduction differential.

Front axle

(1) Use a second forklift truck and firmly secure the lower part of the front axle with the right and left fork blades.

Truck model	Maximum load of service forklift truck
FD100NM1	1350 kg (2976.2 lb.)
FD120NM1	
FDF135NM1	
FD150ANM1	

⚠ WARNING

As the differential is not located at the center of the right to left span of the front axle, firmly secure it to reduce the risk of falling upon removal.

(2) Remove the mounting bolts, and operate the second forklift truck to remove the front axle.
If a second forklift truck is not available, remove as instructed below:

- Remove the mast assembly. See "12. Mast and Forks".
- Always apply some protective cloth before attaching a hoist on and lifting the mast support bearings of the axle housing with a chain or wire rope.
- Remove mounting bolts, and remove the front axle by lifting.

11.4 Disassembly Sequence of Reduction and Parking Brake Assembly

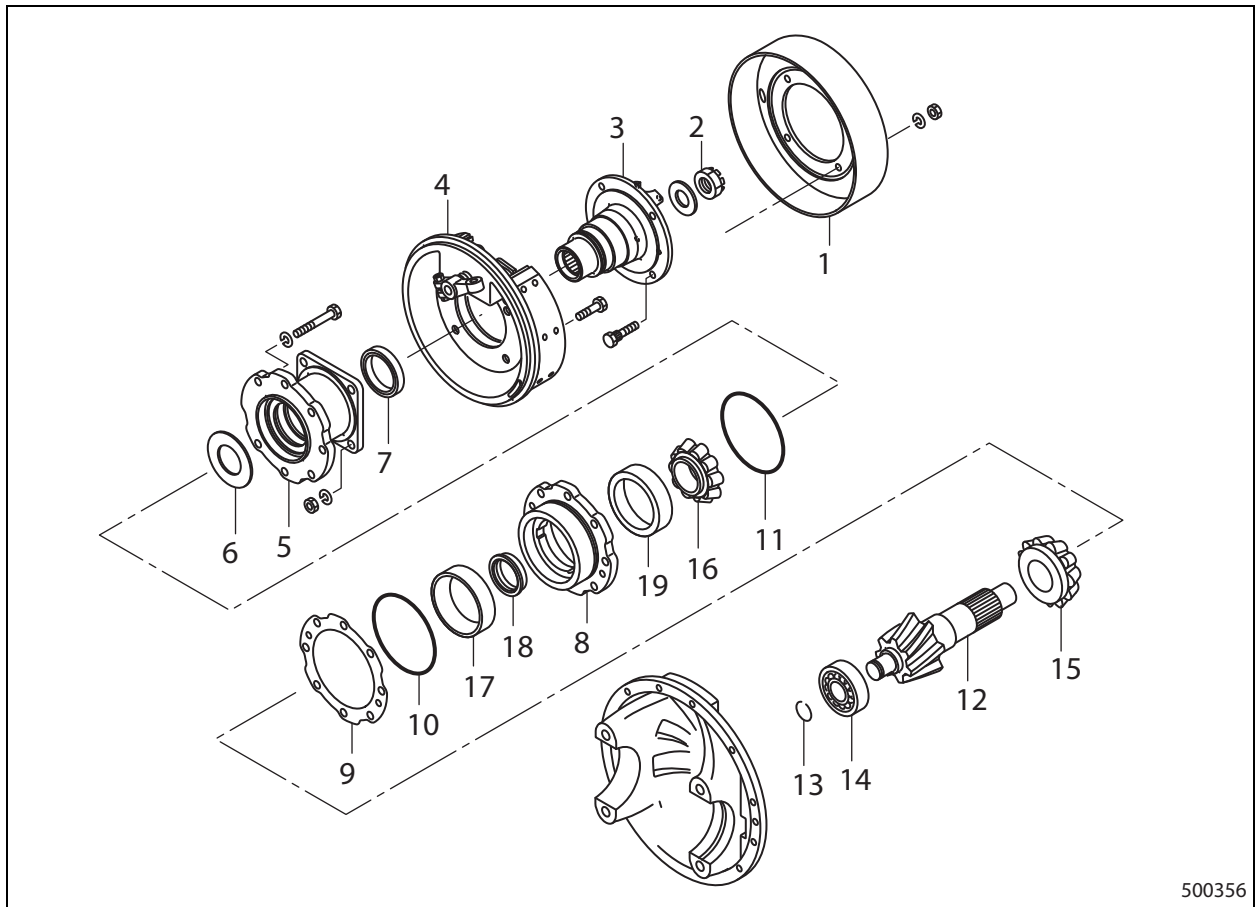

500356

- | | |
|---------------------------|---|
| 1. Parking brake drum | 11. O-ring |
| 2. Self-locking nut | 12. Reduction pinion |
| 3. Input flange | 13. Snapring |
| 4. Parking brake assembly | 14. Roller bearing |
| 5. Parking brake bracket | 15. Tapered roller bearing (inner race) |
| 6. Oil separator | 16. Tapered roller bearing (inner race) |
| 7. Oil seal | 17. Tapered roller bearing (outer race) |
| 8. Bearing retainer | 18. Collar |
| 9. Shim | 19. Tapered roller bearing (outer race) |
| 10. O-ring | |

11.5 Suggestions for Disassembling Reduction and Parking Brake Assembly

Bearing retainer

- (1) Utilize the bolt holes for separation (M14x1.5: 2 places) and thread in jack bolts into them and turn the bolts evenly to pull out the bearing.
- (2) Check the shim thickness, and pay attention not to lose them.

Tapered roller bearing

Remove the inner race using a bearing puller.

13. Troubleshooting

Condition	Possible cause	Action
Continuous gear noise during travel	Reduction bevel gear teeth badly worn	Replace reduction bevel gear
	Improper adjustment or excessive wear of reduction bevel gear bearing	Adjust or replace the bearing
	Hub bearings damaged	Replace the bearing
	Improper tooth contact between the reduction pinion and reduction gear of the output shaft	Adjust the tooth contact
Irregular noise during travel	Reduction gear bearing or hub bearing broken	Replace the bearing
	Differential gear teeth broken or thrust washers worn	Replace differential gear or washer
	Metal chips in axle housing	Wash and change oil
	Bolts that secure the axle shaft or differential carrier loosened	Tighten
Abnormal noise comes out when turning a corner	Fit of differential gears in differential case out of specification due to wear	Replace
	Teeth of differential gear or pinion broken, seized on spider, or worn or damaged	Replace
Differential carrier overheats after traveling	Bearing damaged due to excessive preload	Replace bearing and adjust preload
	Backlash between reduction pinion and reduction gear too small	Adjust tooth contact and backlash
Abnormal noise comes from hub reduction unit	Low oil level or poor oil quality	Add or change oil
	Planetary gears worn or damaged	Replace the planetary gear
	Needle roller bearing worn	Replace the needle roller bearing

7. Disassembling Rear Axle Assembly

7.1 Disassembly Sequence

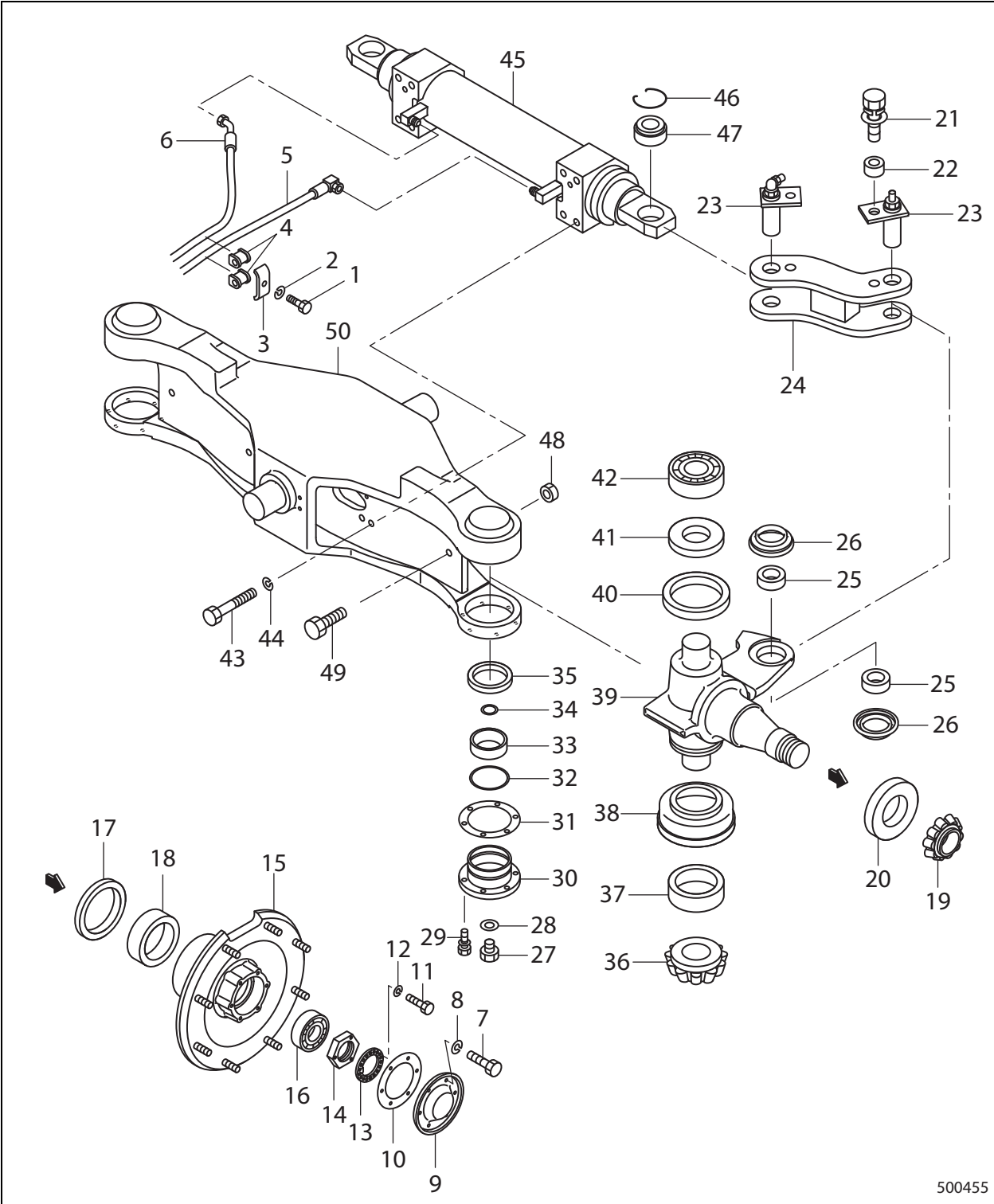

500455

13. Troubleshooting

Condition	Possible cause	Action
Steering wheel effort is heavy	Faulty steering system	See "10. STEERING SYSTEM" for inspection and adjustment
	Defective hydraulic circuit	See "11. HYDRAULIC SYSTEM" for inspection and adjustment
	Insufficient lubrication of the rear axle	Greasing
	Low tire inflation pressure	Adjust inflation pressure
Steering wheel pulls to one side	Differences in the outside diameter of tires between right and left	Replace with a specified tire
	Differences in tire inflation pressure between right and left tires	Adjust inflation pressure
Vibration in steering wheel	Wear or damage in the tapered roller bearing	Replace the bearing
	Faulty steering system	See "10. STEERING SYSTEM" for inspection and adjustment
Local or premature wear of rear tire	Differences in type or inflation pressure between right and left tire	Replace tires with specified ones and adjust inflation pressure correctly

8. Disassembling Wheel Cylinder

8.1 Disassembly Sequence

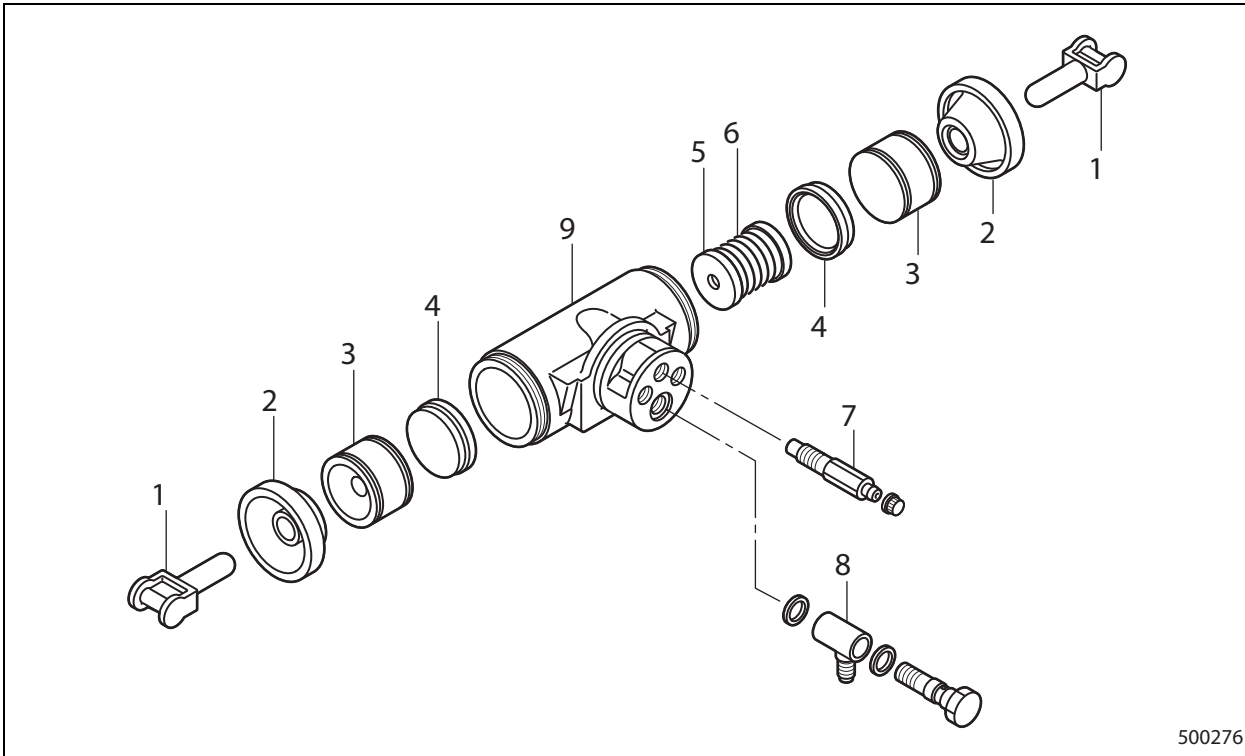

- | | |
|----------------|------------------|
| 1. Push rod | 6. Return spring |
| 2. Dust cover | 7. Bleeder screw |
| 3. Piston | 8. Connector |
| 4. Piston cup | 9. Cylinder body |
| 5. Spring seat | |

Adjust the cam follower of brake control valve with the adjusting bolt to contact with the pedal.

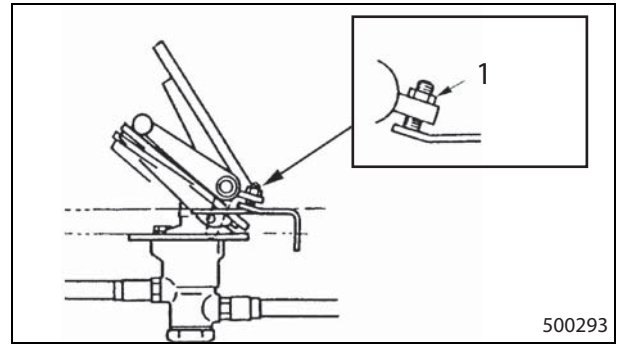

1) Adjusting bolt

⚠ CAUTION

DO NOT change the pedal set angle ($39 \pm 1.5^\circ$) of the brake valve.

23.4 Inspecting Brake Control Valve

Air leak test

- (1) Check the air pressure in air tank to be the specified pressure.
- (2) Release the brake pedal.
- (3) Apply soap and water to the exhaust port of brake control valve, and check for bubbles. If bubbles are seen, the exhaust valve is leaking air.
- (4) Depress the brake pedal fully, and check the bubbles for the valve air leak.
- (5) Remove the exhaust port plug and check the valve for damage.

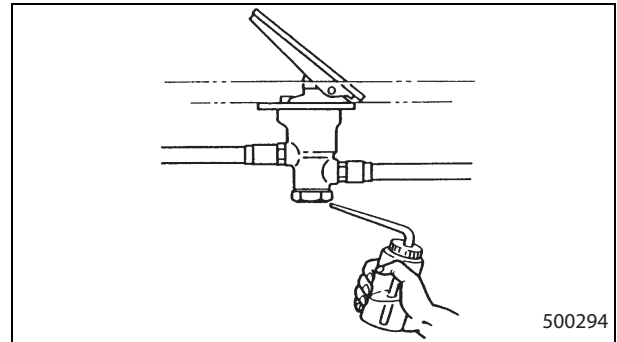

Functional check

The functional check of brake control valve must be performed by 2 persons.

- (1) Attach a R(PT)3/8 connector to the outlet port of brake control valve and connect a pressure gauge.
- (2) Turn ON the engine and raise the air pressure in the tank to the normal level, then turn OFF the engine.
- (3) Have an assistant depress the brake pedal, and make sure the reading of the pressure gauge matches the gauge on the instrument panel.
- (4) Keep the pedal depressed down. If the pressure gauge indicator reading decreases, check for air line leaks.

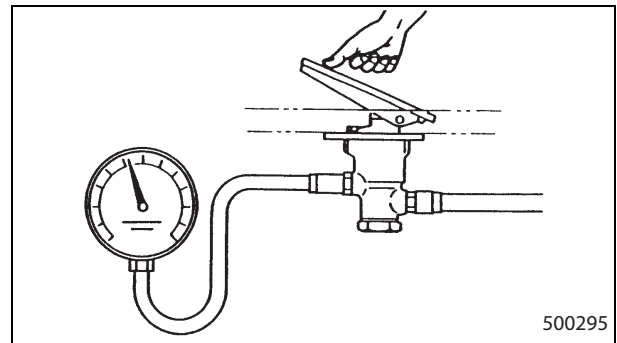

2.2 Steering Valve

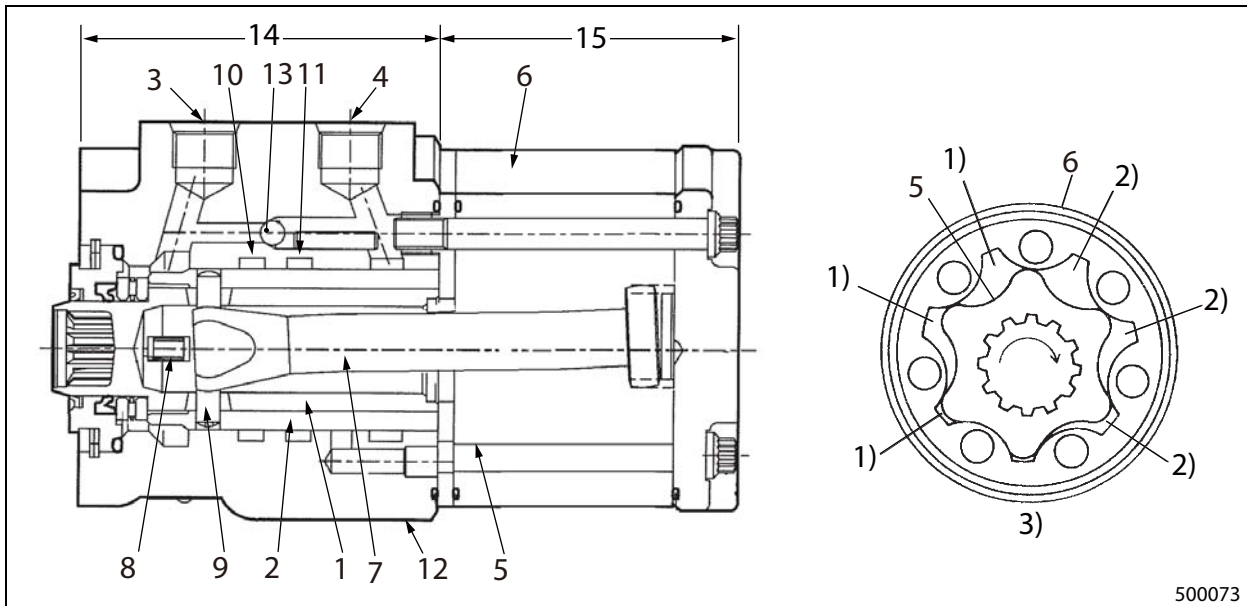

- | | |
|-------------------------|--------------------------|
| 1. Spool | 10. Port L |
| 2. Sleeve | 11. Port R |
| 3. Outlet port (Port T) | 12. Housing |
| 4. Inlet port (Port P) | 13. Check valve |
| 5. Rotor | 14. Rotary valve section |
| 6. Rotor ring | 15. Metering section |
| 7. Drive shaft | 1) Metering pump areas |
| 8. Centering spring | 2) Metering pump areas |
| 9. Pin | 3) Gerotor set |

The steering valve consists of two sections: rotary valve section and metering section.

The rotary valve section consists of spool, sleeve, and housing.

Spool is splined to connect with the steering shaft.

When the spool is turned, the sleeve rotates, which causes the following passages to open:

- (1) Passage from inlet port to metering section
- (2) Passage from metering section to port L or port R
- (3) The passage that allows oil to flow from the steering cylinder to outlet port.

The metering section is a small hydraulic pump consisting of a rotor ring and a rotor called a gerotor set.

The spool and the rotor are commonly connected to the drive shaft. Thus, when the steering wheel is turned, the rotor rotates in the same direction and at the same speed as the steering wheel does.

When the steering wheel is not turned, oil from the inlet port flows to the outlet port and returns to the hydraulic tank.

At this point, the oil passage to metering section is blocked by spool and sleeve.

When the steering wheel is turned clockwise, the oil from inlet port flows into metering pump areas **1)**. The rotor rotates as the steering wheel turns, and the oil in metering pump areas **2)** is forced into the steering cylinder through the port.

When the steering wheel is turned counterclockwise, oil flows in the direction reverse to the above. So the oil is forced into the steering cylinder through port L.

As pressure oil from the inlet port acts as a rotating force to the rotor, the steering wheel can be turned with a little effort.

Normally, the check valve blocks a bypass flow since it is pushed to the left by an oil pressure from the inlet port.

When the oil supply from port of the hydraulic valve stops for some reason, the bypass passage opens to allow the oil from the hydraulic tank to flow into the metering section. When the steering wheel is turned, the metering section acts as a manually-operated pump to allow the oil to flow into the steering cylinder.

6.3 Suggestions for Assembly

Assembling spool and sleeve

Align the spring grooves in the spool and sleeve, then slide the spool into the sleeve while rotating the spool. Ensure that the marks are aligned with each other (the matchmarks made during disassembly or the matchmarks provided by the maker).

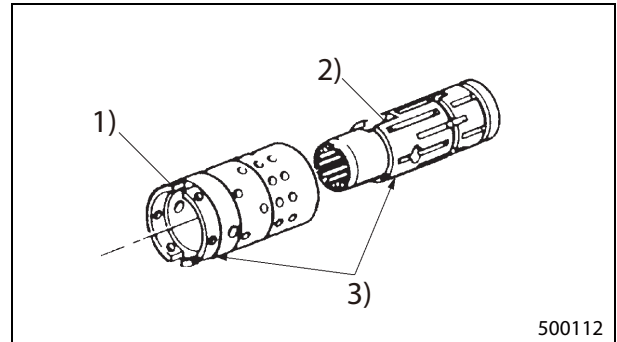

- 1) Spring groove
- 2) Spring groove
- 3) Matchmark

500112

⚠ CAUTION

Be sure that the spool rotates smoothly in the sleeve without any restrictions.

Installing centering spring

- (1) Align the spring grooves in the spool and sleeve assembly, and stand the spool and sleeve assembly on a flat workbench.
- (2) Use a spring insertion tool to install springs. Place three pieces of centering spring back to the back of the other three pieces. Pinch the six pieces of spring with the insertion tool placing the notches on the both ends facing downward. See the illustration on the right.
- (3) Hold one end of the springs with fingers and push the springs into the notches of the spool and sleeve assembly. If the spring insertion tool is not available, insert the springs one by one alternately from the right and left.

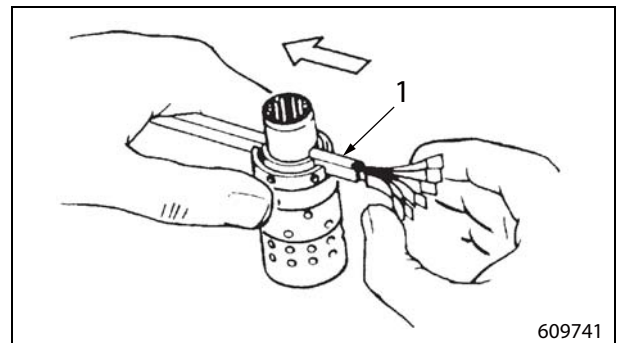

- 1. Special tool

609741

Special tool name	Part number
Spring insertion tool	97157-00100

Inserting spool and sleeve assembly into housing

- (1) Insert the pin into the spool and sleeve hole. Align the pin ends to the sleeve outside diameter.
- (2) Insert the spool and sleeve assembly from the back of housing (as shown in the illustration). Insert the spool-and-sleeve assembly while slowly rotating it with the pin being kept at a horizontal position. Insert the spool and sleeve assembly until its rear end becomes flush with the housing end face. Do not insert farther.

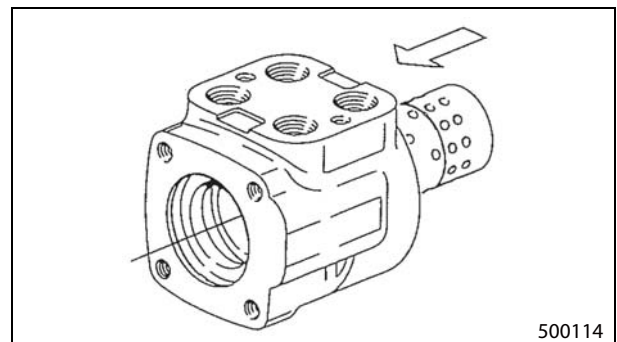

500114

2.7 Flow Regulator Valve

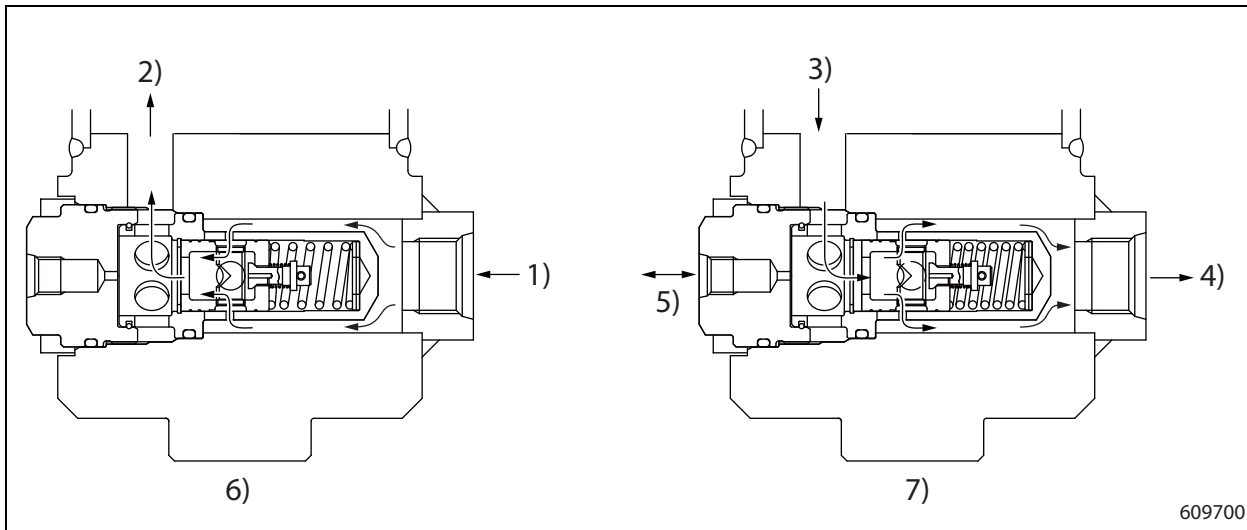

609700

- | | |
|-----------------------|--|
| 1) From control valve | 5) Connected to the other flow regulator valve |
| 2) To cylinder | 6) During ascent |
| 3) From cylinder | 7) During descent |
| 4) To control valve | |

The flow regulator valve will pass the entire amount of working oil fed from the pump while the lift cylinder is raising the mast, but controls the flow rate passing through it by automatically moving down the orifice when the lift cylinder is lowering the mast.

As the result, the descending speed of mast can be maintained constant irrespectively of whether the load is light or heavy.

In addition, since the right and left flow regulator valves are linked together, the lowering speed of right and left cylinders are adjusted to be even.

14. Disassembling and Assembling Control Valve

14.1 Disassembly Sequence

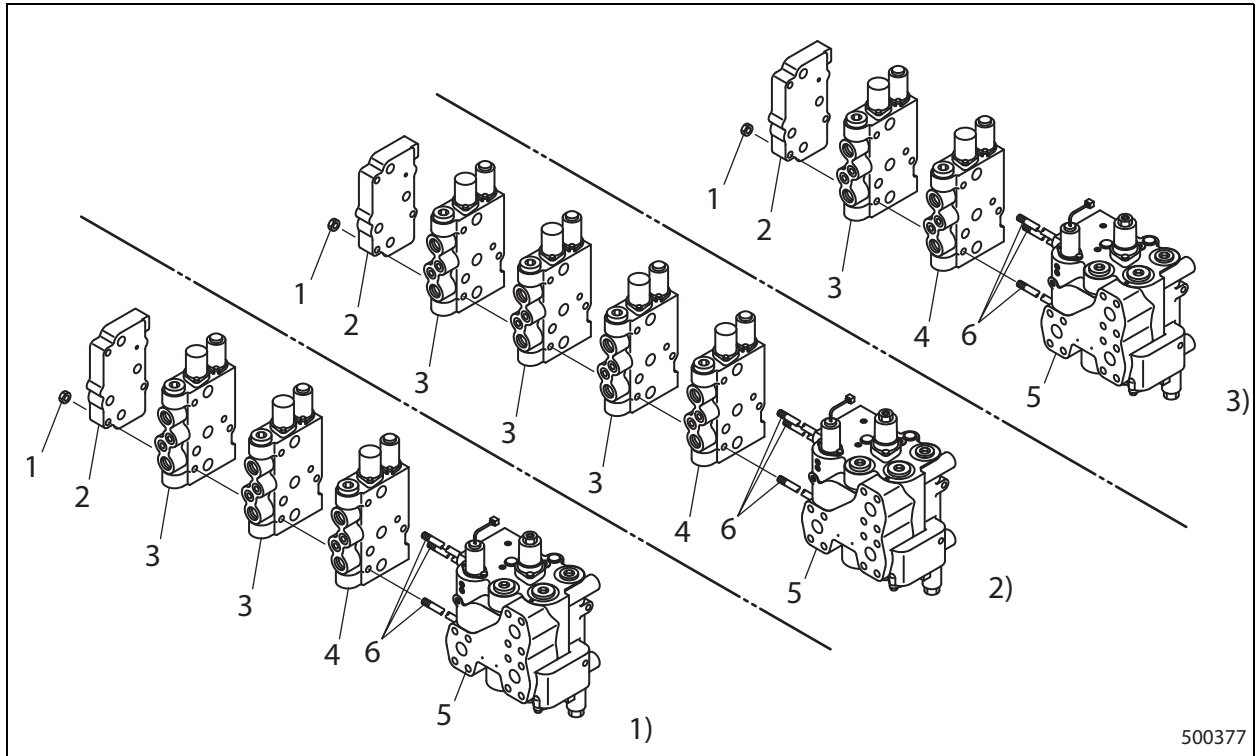

- | | |
|-----------------------------------|----------------------------|
| 1. Nut | 6. Tie rod |
| 2. Block | 1) Three-way control valve |
| 3. Valve assembly for attachments | 2) Four-way control valve |
| 4. Tilt valve assembly | 3) Five-way control valve |
| 5. Inlet valve assembly | |

14.2 Assembly Sequence

Follow the disassembly sequence in reverse to assemble.

14.3 Suggestions for Assembly

Tighten tie rod nuts to the specified torque.

Tightening torque for nut
44.1 ± 4.4 N·m (4.50 ± 0.45 kgf·m) [32.526 ± 3.245 lbf·ft]

Note: Do not use liquid gasket.

Disassembling attachment valve assembly (part 2)

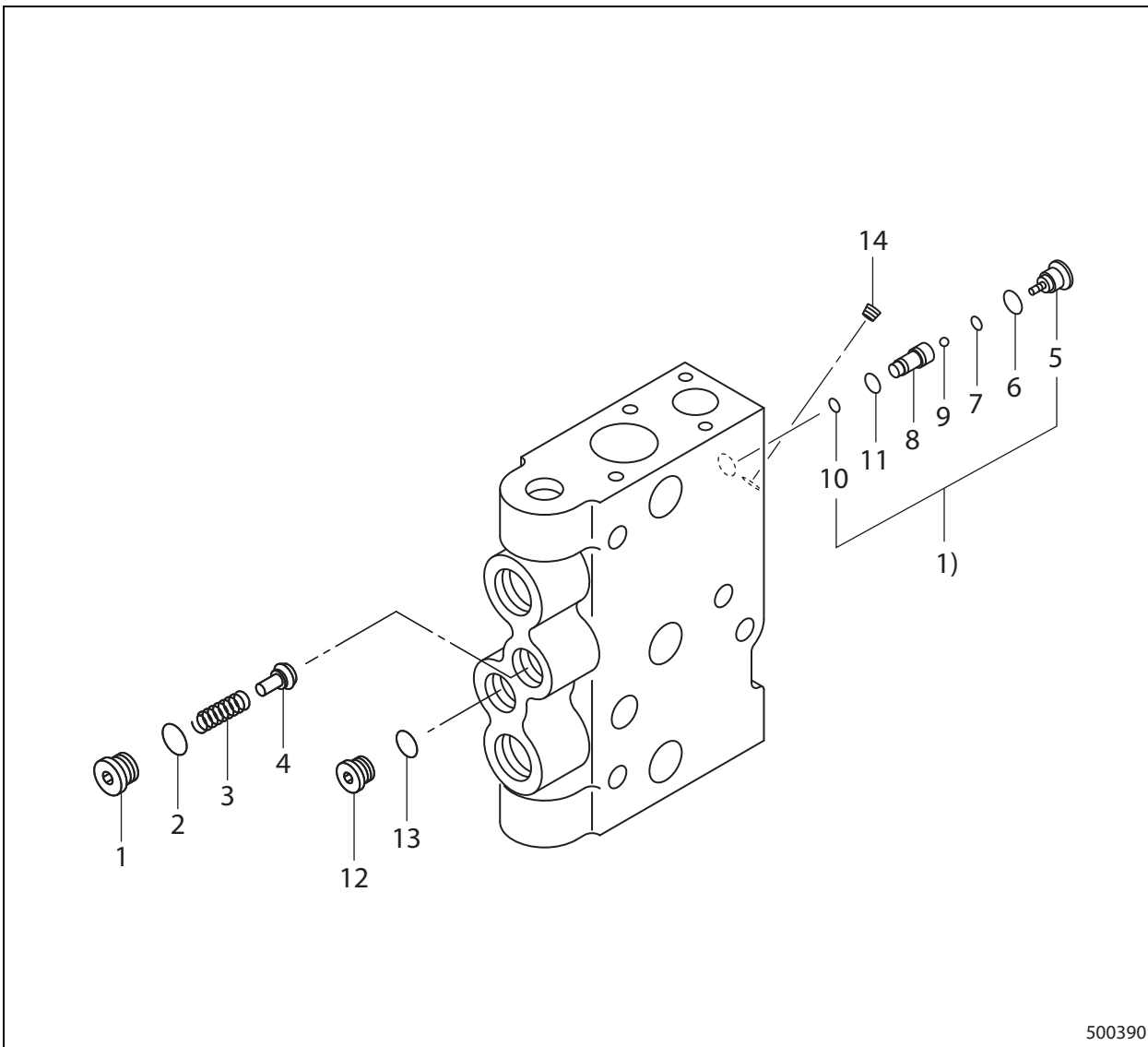

500390

- | | |
|-----------|------------------|
| 1. Plug | 9. Steel ball |
| 2. O-ring | 10. O-ring |
| 3. Spring | 11. O-ring |
| 4. Valve | 12. Plug |
| 5. Plug | 13. O-ring |
| 6. O-ring | 14. Plug |
| 7. O-ring | 1) Shuttle valve |
| 8. Plug | |

- (6) Then raise the pressure by 2 MPa (20 kgf/cm²) [290 psi] for 5 minutes progressively until relief valve set pressure is obtained.

Item	Standard
Valve set pressure	20.6 ^{+0.5} ₀ MPa (210.1 ^{+5.1} ₀ kgf/cm ²) [2987.8 ^{+72.5} ₀ psi]

- (7) During the process of increasing the pressure, pay attention to the oil temperature, pump surface temperature, and listen for abnormal sound from the pump. If the oil temperature or pump temperature abnormally rises, cancel the load and lower the temperature to continue the test operation, or disassemble the pump again to inspect the inside.
- (8) After above Steps (2) through (7) is completed, adjust the relief valve to the specified set pressure, and make sure that the operation speed is normal.

24.3 Control Valve

Oil leak to the outside

Check the oil leak at the positions below:

- Leak from O-ring between housing
- Leak from scraper and O-ring
- Leak from threaded connections

Chapter 12 MAST AND FORKS

1. Specifications

1.1 Mast

Item		Truck model			
		FD100NM1	FD120NM1	FD135NM1	FD150ANM1
Mast model		V120B		4V135B	4V150AB
Mast type		Simplex mast			
Mast dimension (Flange inside width x Flange thickness x Web thickness)	Outer	205 x 32 x 25 mm (8.07 x 1.26 x 0.98 in.)			205 x 36 x 28 mm (8.07 x 1.42 x 1.10 in.)
	Inner	205 x 32 x 25 mm (8.07 x 1.26 x 0.98 in.)			205 x 36 x 28 mm (8.07 x 1.42 x 1.10 in.)
Main roller	Type	Ball bearing			
	Dia x W	S	203 x 52 mm (7.99 x 2.05 in.)		
		M	205 x 52 mm (8.07 x 2.05 in.)		
		L	207 x 52 mm (8.15 x 2.05 in.)		
Side roller	Type	Lubricated needle			
	Dia x W	58 x 40 mm (2.28 x 1.57 in.) [2.28 x 1.57 in.]			
Lift-chain type		BL-1434			BL-1634
Fork width adjustment (outside width)		475 to 2010 mm (18.70 to 79.13 in.)			475 to 2260 mm (18.70 to 88.98 in.)

1.2 Forks

Length	Width x Thickness			
	FD100NM1	FD120NM1	FD135NM1	FD150ANM1
L1219	180 x 72 mm (7.09 x 2.83 in.)	180 x 79 mm (7.09 x 3.11 in.)	180 x 88 mm (7.09 x 3.46 in.)	
L1524	180 x 72 mm (7.09 x 2.83 in.)	180 x 79 mm (7.09 x 3.11 in.)	180 x 88 mm (7.09 x 3.46 in.)	
L1829	180 x 72 mm (7.09 x 2.83 in.)	180 x 79 mm (7.09 x 3.11 in.)	180 x 88 mm (7.09 x 3.46 in.)	
L2438	180 x 75 mm (7.09 x 2.95 in.)	180 x 82 mm (7.09 x 3.22 in.)	180 x 92 mm (7.09 x 3.62 in.)	

Note: The dimensions herein are for standard type. The dimensions differ depending on the specifications.

- (5) Check that the main roller protrusion of lift bracket is 40% or less of the roller diameter when the lift cylinder is fully retracted.
- (6) Place the mast in a vertical position to check the final adjustment.

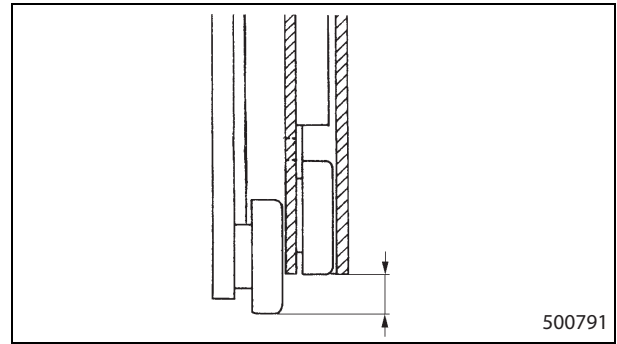

Adjusting back/front and right/left clearances of lift bracket.

- (1) Measure the back/front and right/left clearances of the lift bracket. Adjust if the measured value exceeds the standard.
- (2) Use filler gauges to measure the back/front clearances of lift bracket.
- (3) Use a dial gauge to measure the right/left clearances of lift bracket. Set the dial gauge on the inner mast inside face, and apply the gauge head to the side face of the lift bracket.
Insert a bar between the lift bracket and the inner mast, and press the lift bracket to right and left directions alternately to measure the clearance.
- (4) To adjust the clearance of the lift bracket, remove the mast bracket from the mast referring to removal and assembly procedures, and adjust the roller.
- (5) If the back/front clearance exceeds the standard, replace the main roller with an oversized one.
- (6) If the right/left clearance of side rollers exceeds the standard, adjust the clearance referring to the procedure below:
 - To adjust the clearance, loosen the locknut of side roller bracket and rotate the adjusting bolt.

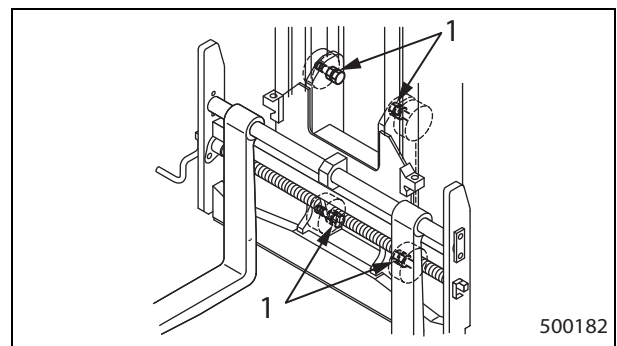
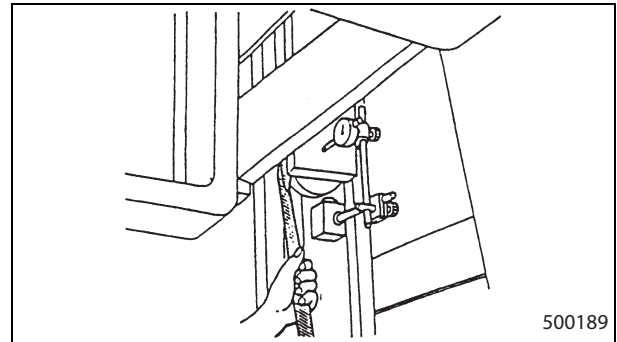



1. Adjusting bolt

10. Troubleshooting

Condition	Possible cause	Action	
Shifting speed of right and left blades is slow, or the shift movement is abnormal	Hydraulic tank oil level is too low	Add hydraulic oil	
	Gear pump delivery rate low	Replace pump assembly	
	Overload relief valve malfunction	Valve opening pressure setting is too low	Adjust overload relief valve
		Pilot valve seat face defect or foreign matter inclusion	Replace overload relief valve assembly, or disassembly the valve and clean
		O-ring in valve case damaged	Replace O-ring
		Pilot valve spring fatigued	Replace overload relief valve assembly
	Cylinder defects	Foreign particles in packing	Replace rod packing
		Scratches on bore of rod packing	Replace rod packing
		Piston O-ring damaged	Replace piston O-ring
		Abnormal distortion	Replace
Shift movement is not smooth (jamming or rattling)	Rust or scratches on guide bar	Repair and apply grease	
	Scars on lift bracket surface to contact with fork blade	Repair and apply grease	
	Scars on fork guide bar	Repair and apply grease	
Fork tips are different in height	Distortion of forks	Replace	
	Off-center loading	Instruct operator to handle loads within capacity	

2.2 Metric Coarse Thread

Nominal size mm	Pitch mm	With spring washer								
		 500247			 500248			 500249		
		N-m	kgf-m	lbf-ft	N-m	kgf-m	lbf-ft	N-m	kgf-m	lbf-ft
10	1.5	33.3	3.40	24.56	43.1	4.39	31.79	67.7	6.90	49.93
12	1.75	58.8	6.00	43.37	76.5	7.80	56.42	115.7	11.80	85.33
14	2	96.4	9.83	71.10	124.5	12.70	91.82	182.4	18.60	134.53
16	2	147.1	15.00	108.49	191.2	19.50	141.02	274.6	28.00	202.53
18	2.5	203.0	20.70	149.72	264.8	27.00	195.30	383.4	39.10	282.78
20	2.5	286.4	29.20	211.23	371.7	37.90	274.15	536.4	54.70	395.62
22	2.5	383.4	39.10	282.78	499.2	50.90	368.18	725.9	74.02	535.39
24	3	492.3	50.20	363.10	640.4	65.30	472.33	924.8	94.30	682.09
27	3	724.7	73.90	534.50	942.2	96.08	694.92	1350.4	137.70	995.99
30	3.5	969.9	98.90	715.35	1259.2	128.40	928.72	1843.7	188.00	1359.82
33	3.5	1328.8	135.50	980.06	1727.0	176.10	1273.75	2477.2	252.60	1827.06
36	4	1676.0	170.90	1236.13	2180.0	222.29	1607.86	3199.9	326.29	2360.09
39	4	2219.2	226.29	1636.77	2884.1	294.09	2127.17	4118.8	419.99	3037.82
42	4.5	2754.7	280.90	2031.73	3581.4	365.20	2641.46	5137.7	523.89	3789.31

(6) Switches, control, and protective devices

Symbol	Name
	Switch (N.O)
	Switch (N.C)
	Two position switch
	Emergency switch
	Push button switch
	Switch (Auto return)

Symbol	Name
	Oil pressure switch
	Magnetic contactor
	Fuse
	Thermistor
	Magnetic coil
	Proximity sensor

(7) Indicators, lamps, and signal devices

Symbol	Name
	Lamp
	Buzzer

Symbol	Name
	Horn

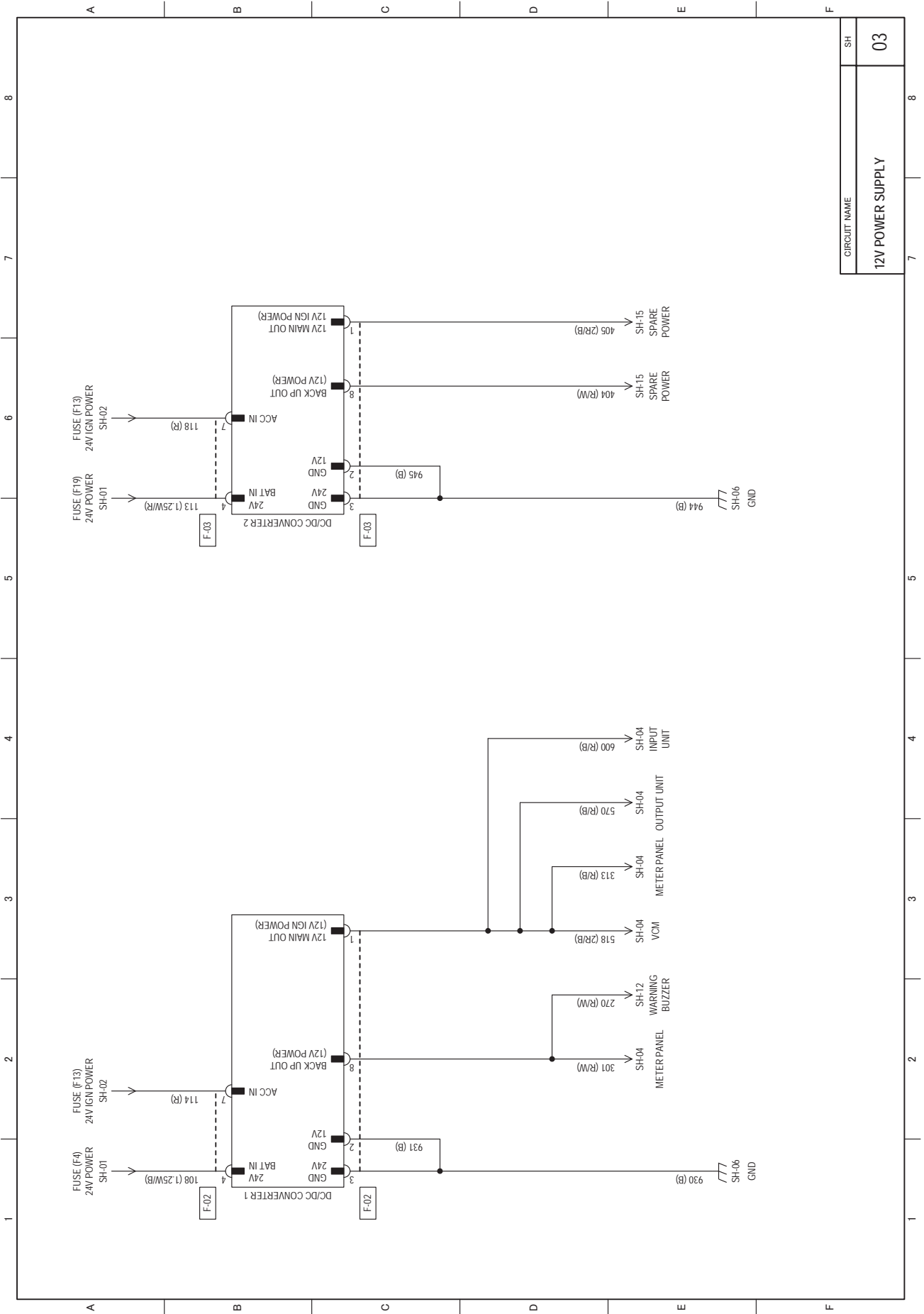

CIRCUIT NAME	SH
12V POWER SUPPLY	03

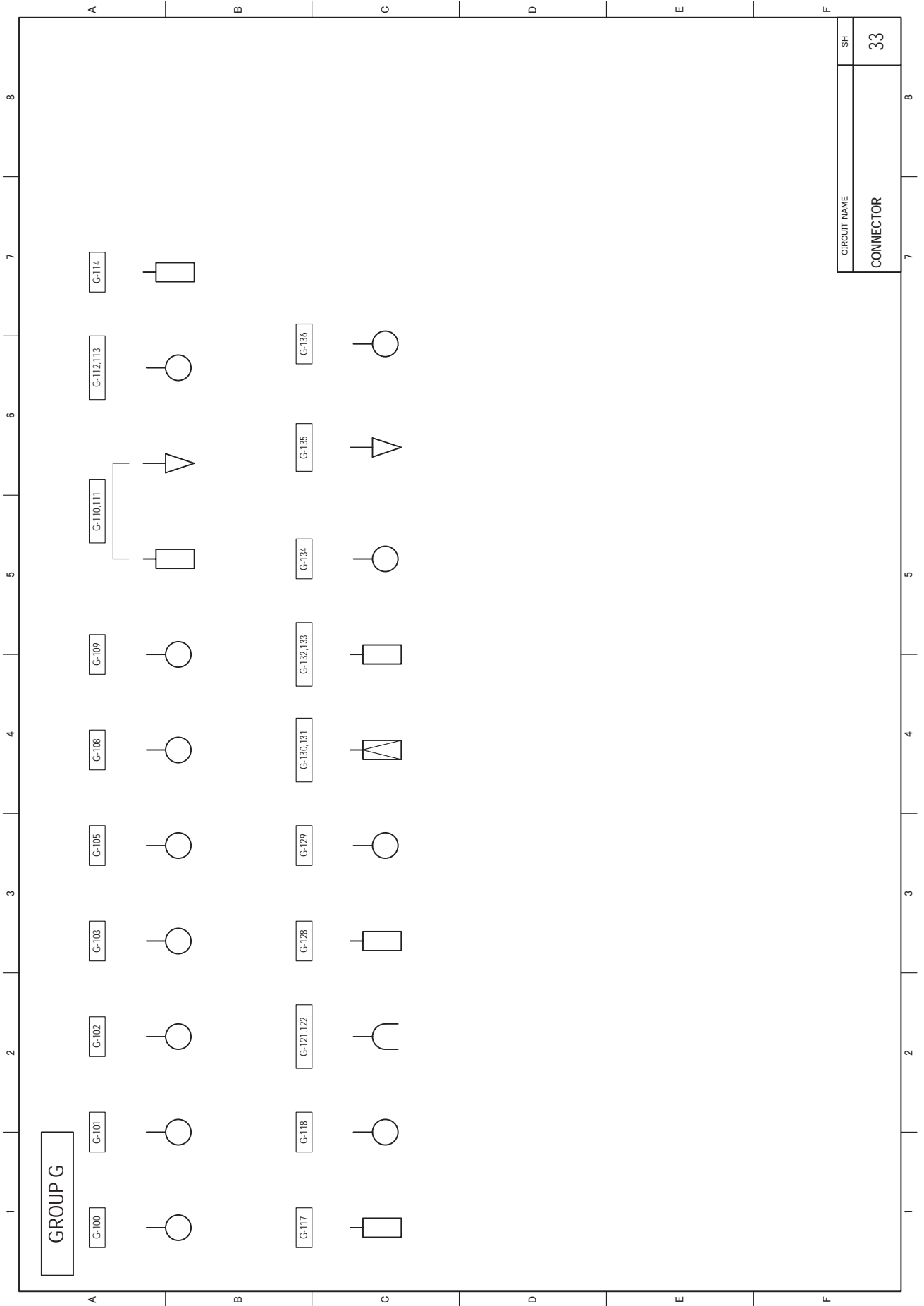

M E M O

STRUCTURE AND OPERATION

<24V-40A (without vacuum pump), 12V-80A>

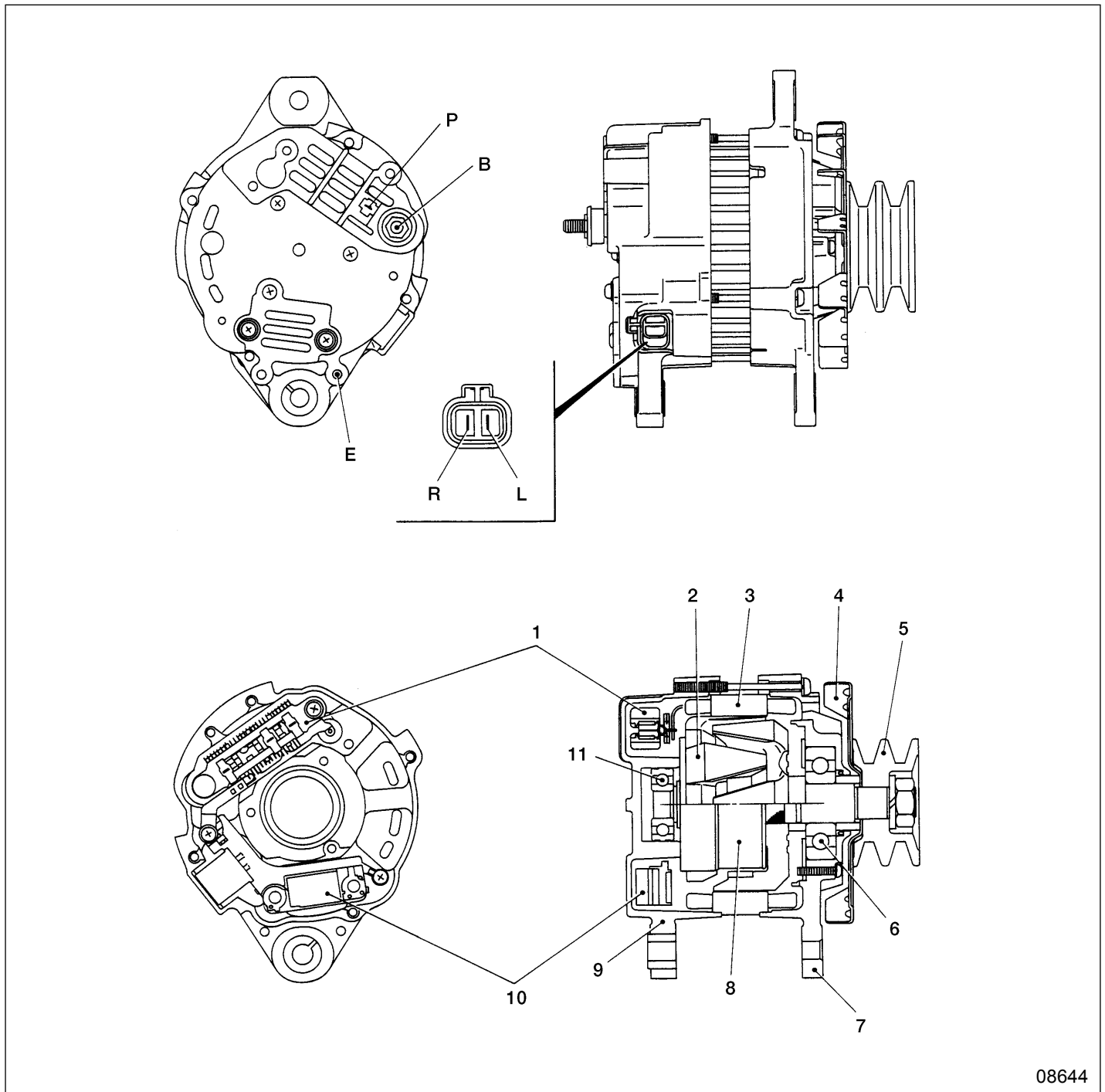

08644

- | | | |
|-------------------|-----------------|---------------|
| 1 Rectifier | 7 Front bracket | B: Terminal B |
| 2 Rotor assembly | 8 Field coil | E: Terminal E |
| 3 Stator assembly | 9 Rear bracket | L: Terminal L |
| 4 Fan | 10 Regulator | P: Terminal P |
| 5 Pulley | 11 Rear bearing | R: Terminal R |
| 6 Front bearing | | |

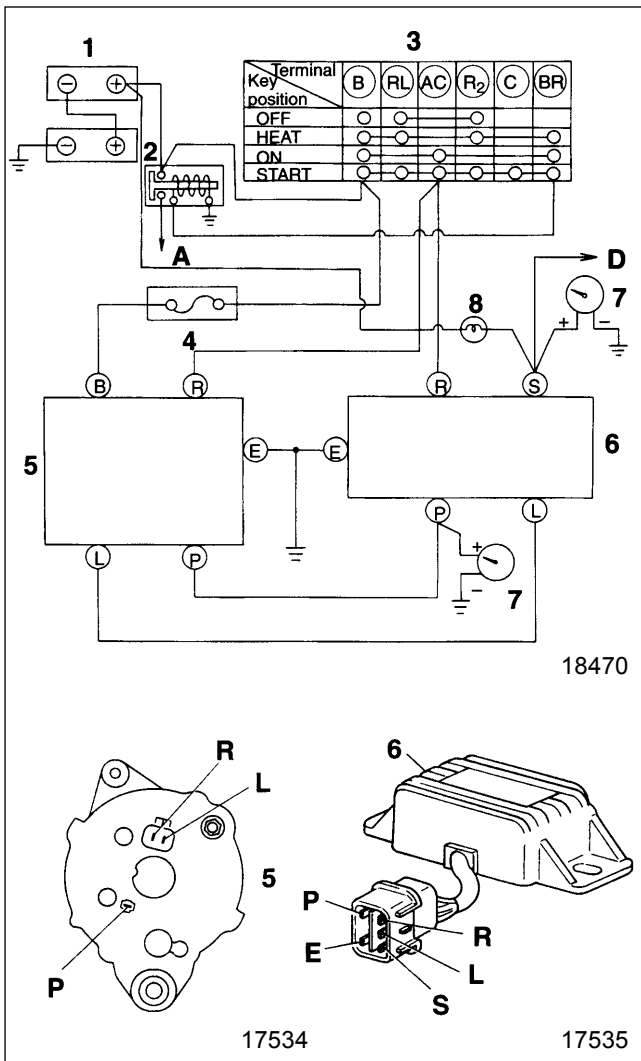

(3) Checking output voltage at terminal S

- Connect the voltmeter 7 and lamp 8 as shown.
- Set the starter switch 3 to the START position and measure the voltage between the safety relay 6 (terminal S) and the earth in the cranking state.
- If the reading is out of the standard value, the following points are likely to be defective. Check all the parts and replace if defective.
 - When the reading is close to the battery voltage, the safety relay 6 is defective.
 - When the reading is 0V, the following problems are suspected.
 - Defective wiring
 - Incorrectly connected connector
 - Defective starter relay
 - Defective starter switch
- Start the engine and let it run at idle (600 rpm or more).
- Measure the voltage at terminal P.
- If the reading is out of the standard value, replace the alternator 5.
- In the idling state, check to ensure that the lamp 8 does not come on. When the voltage at terminal P is normal and the lamp comes on, replace the safety relay 6.

ALTERNATOR <24V-40A (without vacuum pump)>

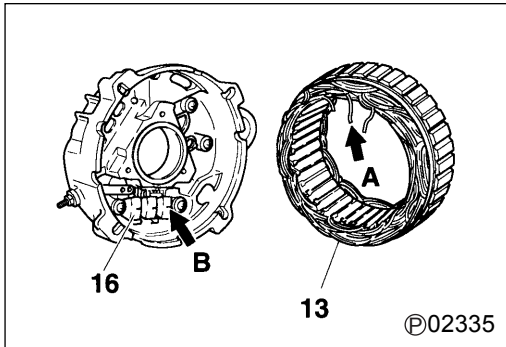

13 Stator assembly

[Removal]

- Disconnect the leads A and remove the stator assembly 13 from the rectifier 16.
The leads are soldered to the diode leads B of the rectifier. (Three places)

CAUTION

De-soldering should be done quickly (in about 5 seconds or less).
The diodes will be damaged if heated for a longer time.

- For installation, reverse the order of removal.

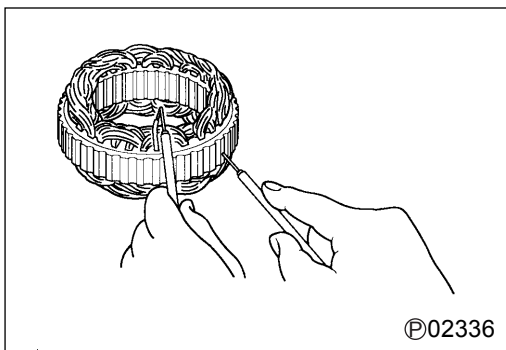

[Inspection]

(1) Continuity between leads

- Check to ensure that there is continuity between each lead.
- If there is no continuity, the leads are open-circuited. Replace the stator assembly 13.

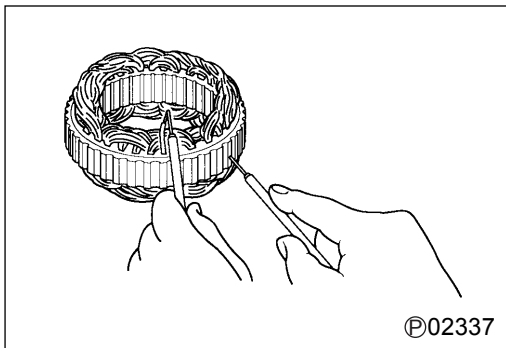

(2) Continuity between each lead and core

- Check to ensure that there is no continuity between each lead and the core.
- If there is continuity, it means a short circuit. Replace the stator assembly 13.

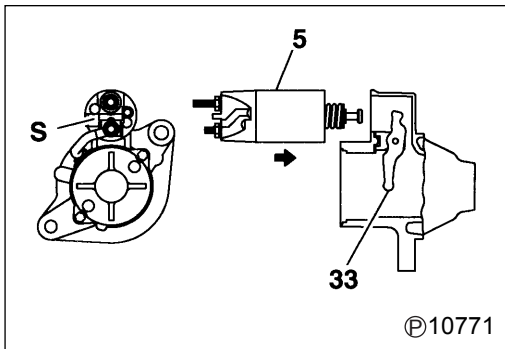

5 Magnet switch

[Installation]

Install the magnet switch 5 on the lever assembly 33 with terminal S in the direction shown.

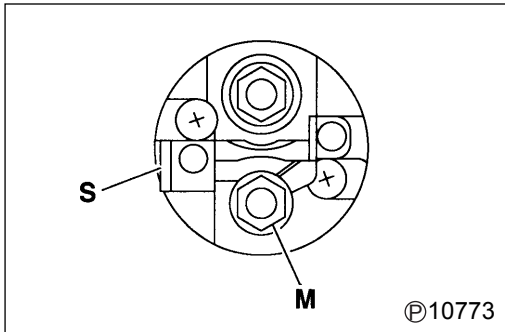

[Inspection]

(1) Open circuit test on coil

- Check to ensure that there is continuity between terminals S and M.
- If there is no continuity, replace the magnet switch 5.

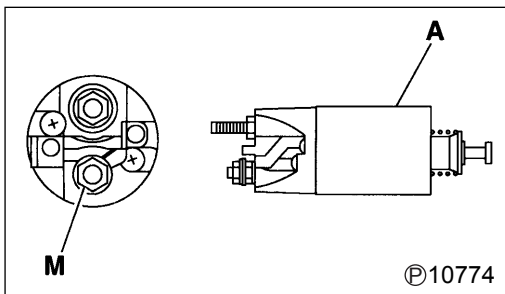

- Check to ensure that there is continuity between terminal M and body A.
- If there is no continuity, replace the magnet switch 5.

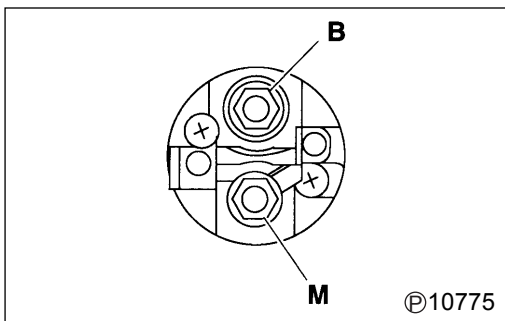

(2) Contact fusion check

- Check to ensure that there is no continuity between terminals B and M.
- If there is continuity, replace the magnet switch 5.

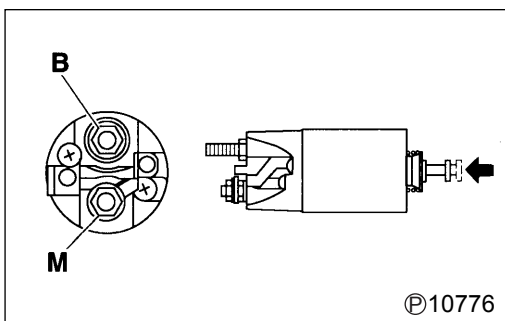

(3) Contact contacting check

- Push the end of the magnet switch 5 in to close the internal contact. In this state, check to ensure that there is continuity between terminals B and M.
- If there is no continuity, replace the magnet switch 5.

Service standards

Unit: mm (in.)

Location	Maintenance item		Standard value	Limit	Remedy	
4	Outer valve spring	Free length	6D16	67.0 (2.64)	64.0 (2.52)	Replace
			6D16-TLE	68.3 (2.689)	65.3 (2.571)	
		Installed load [at 47.8 mm (1.88 in.) installed length]	6D16	330 N (33.5 kgf) [74.5 lbf]	290 N (29.7 kgf) [65.2 lbf]	Replace
			6D16-TLE	390 N (40.0 kgf) [87.7 lbf]	350 N (35.5 kgf) [65.2 lbf]	
	Squareness		–	2.5 (0.0984)	Replace	
5	Inner valve spring	Free length	6D16	55.1 (2.17)	52.1 (2.05)	Replace
			6D16-TLE	65.1 (2.563)	61.5 (2.421)	
		Installed load [at 40.5 mm (1.59 in.) installed length]	6D16	92 N (94 kgf) [20.7 lbf]	78 N (8.0 kgf) [17.5 lbf]	Replace
			6D16-TLE	155 N (15.8 kgf) [34.9 lbf]	130 N (13.4 kgf) [29.3 lbf]	
	Squareness		6D16	–	2.0 (0.0787)	Replace
		6D16-TLE	–	2.5 (0.0984)	Replace	
7	Exhaust valve	Stem outside diameter		$\phi 8.93$ to 8.94 ($\phi 0.3516$ to 0.3520)	$\phi 8.85$ ($\phi 0.348$)	Replace
		Sinkage from cylinder head bottom surface		1.3 to 1.7 (0.0512 to 0.0670)	2.0 (0.0787)	Inspect every location
		Valve margin		1.5 (0.0591)	1.2 (0.0472)	Reface or replace
8	Inlet valve	Seat angle		45°	–	Correct
		Stem outside diameter		$\phi 8.96$ to 8.97 ($\phi 0.3528$ to 0.3531)	$\phi 8.85$ ($\phi 0.348$)	Replace
		Sinkage from cylinder head bottom surface		1.1 to 1.5 (0.0433 to 0.0591)	1.8 (0.0709)	Inspect every location
		Valve margin		1.5 (0.0591)	1.2 (0.0472)	Reface or replace
		Seat angle		45° ± 15'	–	Correct
7, 15	Exhaust valve stem-to valve guide clearance [Basic diameter: 9 mm (0.354 in.)]		0.07 to 0.10 (0.00276 to 0.00394)	0.2 (0.00787)	Replace	
8, 16	Inlet valve stem-to-valve guide clearance [Basic diameter: 9 mm (0.354 in.)]		0.04 to 0.06 (0.00157 to 0.00236)	0.15 (0.00591)	Replace	
17	Exhaust valve seat width		1.8 to 2.2 (0.0709 to 0.0866)	2.8 (0.110)	Correct or replace	
18	Inlet valve seat width		1.8 to 2.2 (0.0709 to 0.0866)	2.8 (0.110)	Correct or replace	
20	Cylinder head	Bottom surface distortion		0.08 (0.00315) or less	0.2 (0.00787)	Correct or replace
		Height from top to bottom surface		94.9 to 95.1 (3.736 to 3.744)	94.5 (3.72)	Replace

PISTONS, CONNECTING RODS, AND CYLINDER LINERS

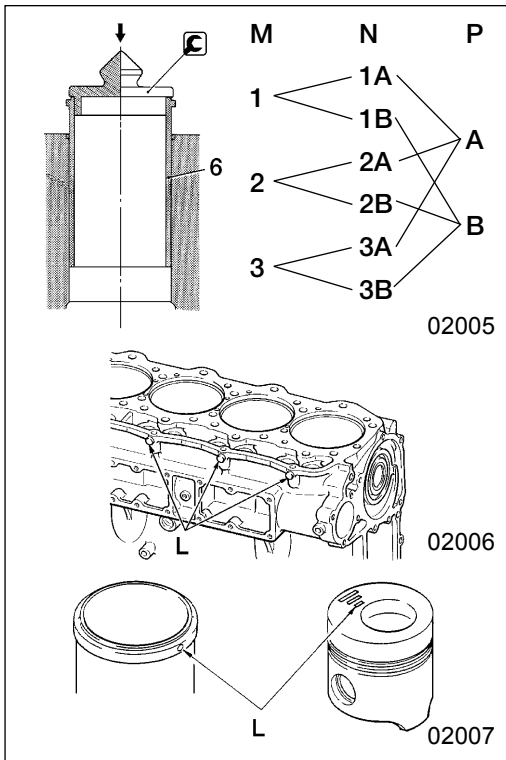

[Installation]

- Apply engine oil to the outside surface of the cylinder liner 6.
- Insert the cylinder liner into the crankcase and press it into position using the  Cylinder Liner Installer. Push down evenly on the entire upper surface of the Cylinder Liner Installer.

CAUTION

- Size marks L are provided on the cylinder liner 6, piston, and crankcase (6 places). When the cylinder liner is replaced, select the proper one according to the size marks on the crankcase and the piston, as shown in the illustration.

M: Crankcase size mark

N: Cylinder liner size mark

P: Piston size mark

- The cylinder liners are of a thin design. Handle them with care, and do not subject them to hammer blows or other severe shocks.

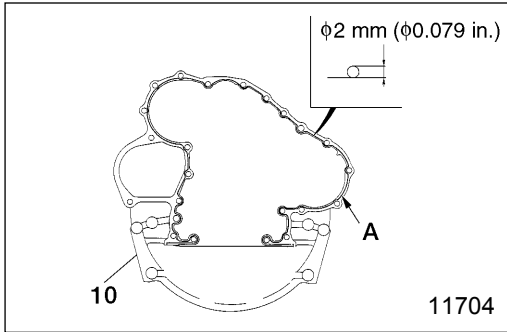

10 Flywheel housing

[Installation]

- Apply an even, unbroken bead of sealant A to the crankcase mounting surface of the flywheel housing 10.
- Fit the flywheel housing 10 onto the crankcase within 3 minutes of applying the sealant A.

CAUTION

- Ensure that the sealant application position on the flywheel housing 10 is clean before applying sealant.
- When fitting the flywheel housing 10, hold it firmly in position to prevent spreading the sealant.
- After fitting the flywheel housing 10, wait at least an hour before starting the engine.
- Apply a new bead of sealant A whenever the mounting bolts of the flywheel housing 10 have been loosened.

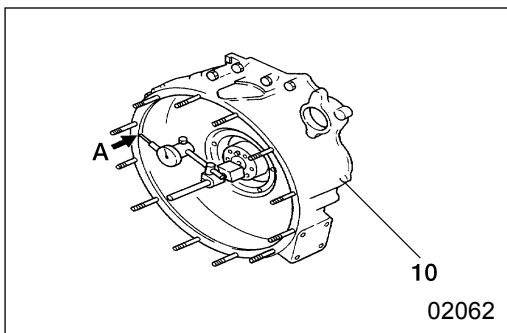

[Inspection]

- Rotate the crankshaft and check the extent of eccentricity at the joint A of the flywheel housing 10.
- If eccentricity exceeds the specified limit, carry out reassembly.
- If eccentricity still exceeds the specified limit after reassembly, replace the defective part(s).

CRANKSHAFT AND CRANKCASE

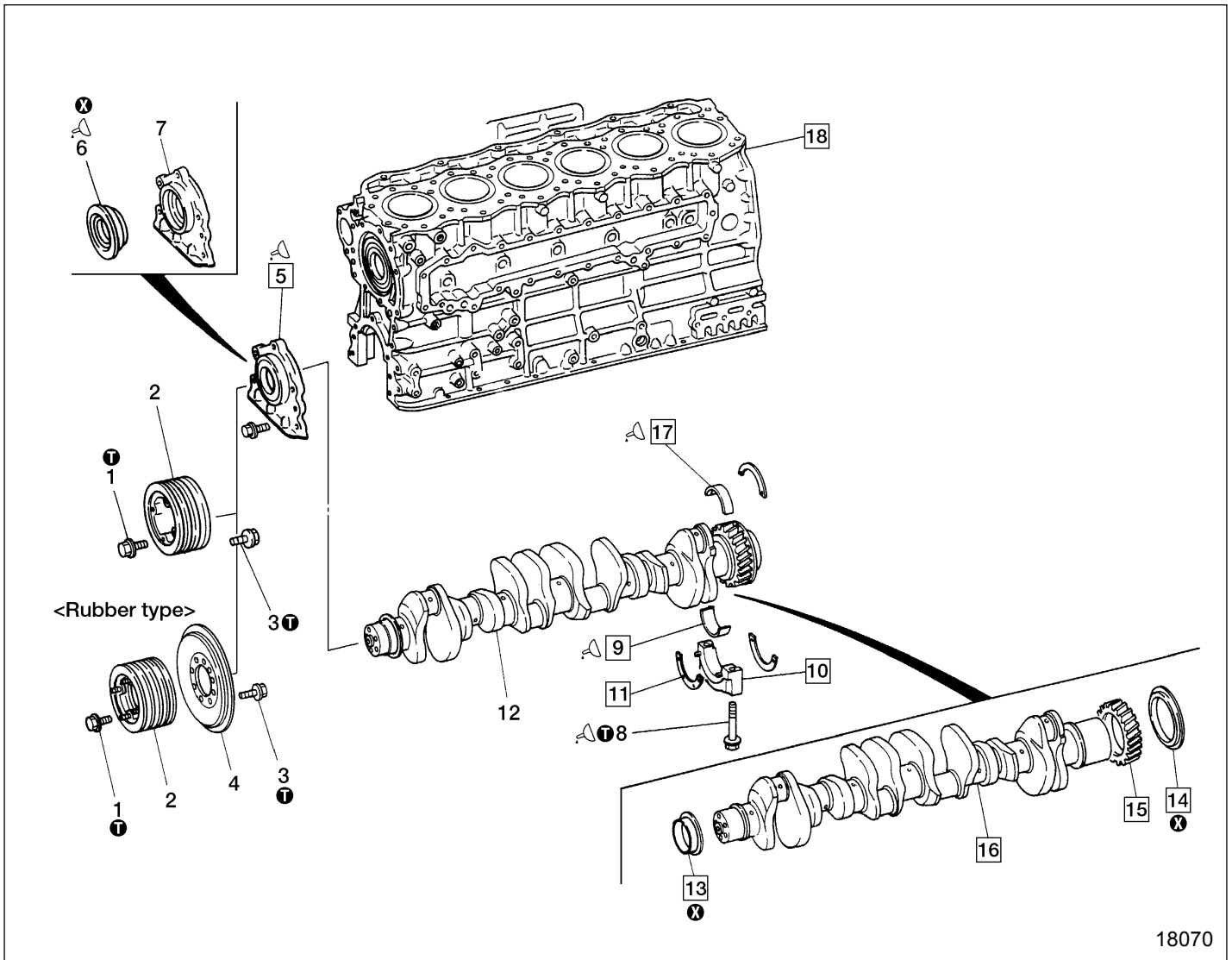

18070

● Pre-disassembly inspection

📖 P.11-69

● Disassembly sequence

- | | | |
|------------------------|---------------------------|-----------------------|
| 1 Bolt | 8 Bolt | 15 Crankshaft gear |
| 2 Crankshaft pulley | 9 Lower main bearing | 16 Crankshaft |
| 3 Bolt | 10 Main bearing cap | 17 Upper main bearing |
| 4 Torsional damper | 11 Thrust plate | 18 Crankcase |
| 5 Front cover assembly | 12 Crankshaft assembly | |
| 6 Front oil seal | 13 Front oil seal slinger | ⓧ: Non-reusable part |
| 7 Front cover | 14 Rear oil seal slinger | |

● Assembly sequence

Reverse the order of disassembly.

General Explanation of This Manual

● Specifications

Particulars relative to maintenance service are made.

● Structure and operation

(1) Regarding conventional equipment, descriptions are made in brief.

(2) Regarding new equipment, descriptions of system and operating condition are made in detail.

● Troubleshooting

Symptoms of troubles and possible causes are described comparatively.

● Inspection and adjustment mounted in vehicle

Descriptions are made regarding inspection and adjustment of units mounted in vehicle.

● Service procedure

In principle, an explanation is given at the spread title page so that the service procedure can be understood.

Servicing points are explained as a supplementary explanation.

Regarding the design of this manual

CLUTCH BODY

21

Pressure Plate and Lever Assembly

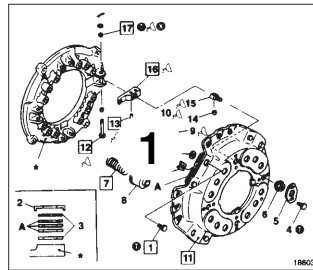

◆ Disassembly sequence

- 1 Bolt
- 2 Washer
- 3 Washer
- 4 Bolt
- 5 Lo
- 6 Su
- 7 Pin
- 8 Pressure spring cap
- 9 Return spring
- 10 Release lever plate
- 11 Clutch cover
- 12 Release lever pin
- 13 Support lever pin
- 14 Bushing
- 15 Support lever
- 16 Release lever
- 17 Bushing

2 Pressure plate & lever assembly

3 Clutch disc

- Flywheel
- ▲ Positioning pin (at 2 places)
- Non-reusable part

◆ Assembly sequence

- 15 → 17 → 1
14 → 15 → 13
7 → 6 → 5 → 4 → 3 → 2 → 1

Repair kit: clutch release

Service standards

Unit: mm

Location	Maintenance item	Standard value (Basic diameter in [])	Limit	Remedy
1, A	Clearance between strap bolt and strap plate	0.01 to 0.16	0.3	Replace
7	Pressure spring Installed load (installed length 49.1)	8650 N (90.2 kgf)	750 N (16.7 kgf)	Replace
2	Pressure spring	2.9 or less	5.0	Replace
10	Clearance between pin and bushing	[10] 0.06 to 0.16	0.4	Replace
10	Release lever	53.8 ± 0.7	Mutual difference 0.5 or less	Adjust

◆ Tightening torque

Unit: N · m (kgf · m)

Location	Parts to be	Tightening torque	Remarks
1	Strap bolt (securing str)	39 to 59 (4 to 6)	—
4	Bolt (securing lock plate)	5.9 to 7.8 (0.6 to 0.8)	Wet

▲ Lubricants

Location	Points of application	Kinds	Quantity
1	Threads of strap bolt	LOCTITE 212	As required
10, 16	Sliding surfaces of release bushing	Molybdenum disulfide grease	As required
12, 17	Sliding surfaces of support bushing	Molybdenum disulfide grease	As required
13, 14	Sliding surfaces of support release lever	Molybdenum disulfide grease [NLGI No. 2 (L soap)]	As required

◆ Special tools

Unit: mm

Location	Tool name and shape	Part No.	Application
11	Clutch Installer	MH061051	Removal and installation of clutch cover
5	Clutch Master Plate	MH062291	Release lever plate height adjustment

◆ Service procedure

1 A Clearance between strap bolt and strap plate

If the measurement exceeds the limit, replace the defective part.

A: Strap plate

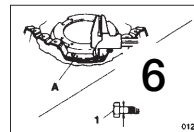

7 Installation of pressure spring

If pressure plate 19 has been reground, insert adjusting washer A corresponding to the amount of reground in the space between the pressure plate and pressure spring 7.

Regrind amount	Type and no. of washers
Less than 1 mm	Not required
1 mm or more to less than 2 mm	One 1.2-mm
2 mm or more to less than 3 mm	Two 1.2-mm or one 2.3-mm

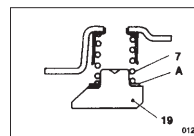

1. Illustration for disassembly and assembly or removal and installation: 3-D exploded view of component parts is displayed.
 - 1a. Names of parts show an example of the disassembly (removal) sequence.
 - 1b. When the assembly (installation) sequence differs from the disassembly (removal) sequence, an example of the assembly (installation) sequence is shown.
2. Service standards are shown collectively, classified by location.
3. Tightening torques are shown collectively, classified by location.
4. Points of lubricant, fluid and sealant application are shown collectively, classified by location.
5. Special tools to be used are shown collectively, classified by location.
6. When it is considered hard to understand the service procedure, just by the foregoing description, a supplementary description of the service procedure is given.

STRUCTURE AND OPERATION

6. Automatic Timer

The automatic timer utilizes a mechanical arrangement to adjust the injection timing in accordance with the engine speed. The automatic timer is mounted on the injection pump camshaft using a round nut. Via a driving disk, it is driven by the air compressor crankshaft or pump drive shaft.

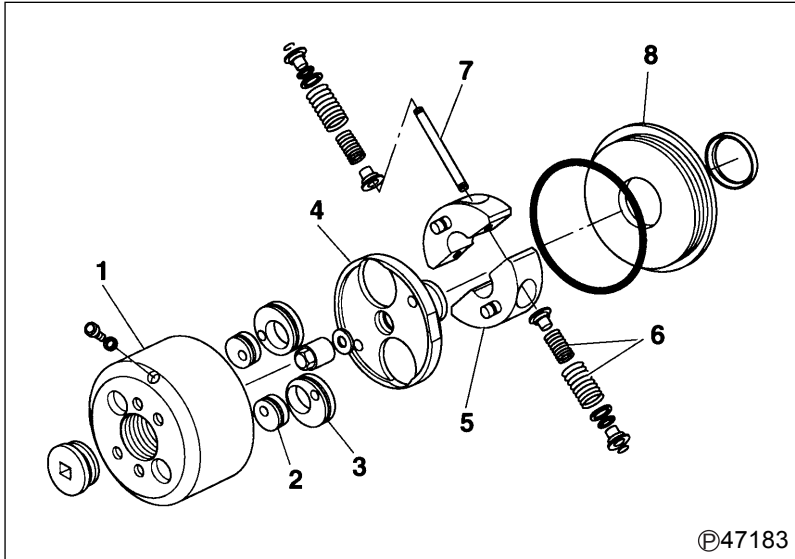

- 1 Timer housing
- 2 Eccentric cam (small)
- 3 Eccentric cam (large)
- 4 Timer holder
- 5 Flyweight
- 6 Timer spring
- 7 Pilot pin
- 8 Cover

©47183

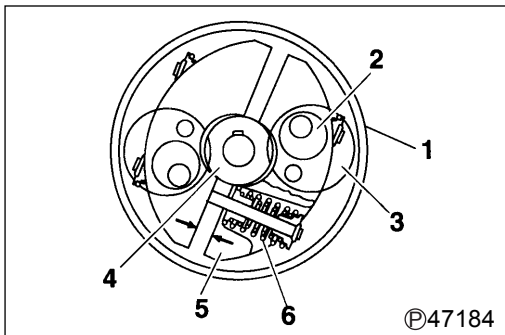

● With engine stationary

With the engine stationary, flyweight 5 is held against timer holder 4 by the force of timer spring 6.

©47184

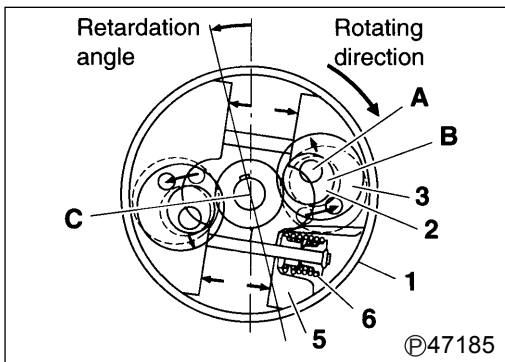

● With engine running

As the engine speed increases, the centrifugal force exerted on flyweight 5 matches the force of timer spring 6. As the engine speed increases further, the centrifugal force overcomes the force of spring, causing the flyweight to move outwards. As the flyweight moves outwards, eccentric cam (small) 2 rotates in the reverse direction of the shaft rotation about pin A of the timer housing. Also, center B of eccentric cam (large) 3 rotates in the reverse direction of the shaft rotation about center C of the timer. The eccentric cam (large) has been fit into timer holder 4. Therefore, the movement of the eccentric cam (large) is transmitted to the timer holder. The maximum retard is achieved when the back of the flyweight bottoms against the inner surface of timer housing 1.

©47185

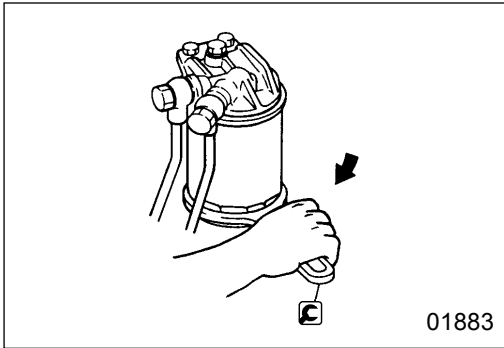

◆ Service procedure

4 Fuel filter [Removal]

WARNING

- Fuel is highly flammable; keep it away from flames and sources of heat.
- To minimize the risk of fire, wipe up any spilled fuel.

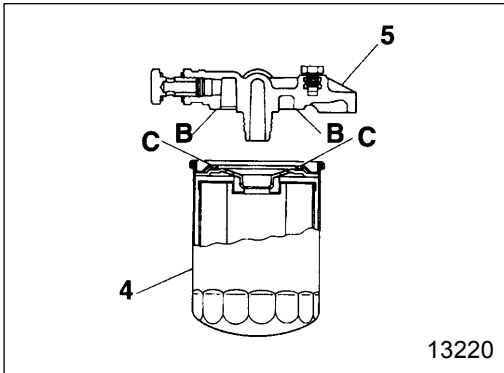

[Installation]

WARNING

Use of an unsuitable fuel filter 4 can lead to fuel leaks and fires. Be sure to use a genuine Mitsubishi filter.

- To fit the fuel filter 4, turn it until the gasket C touches surface B of the fuel filter head 5. Then, tighten the filter by 3/4 to 1 turn. Be sure to turn the filter by hand.
- Start the engine and check for fuel leaks.

INJECTION PUMP DRIVE <Laminated Coupling Type>

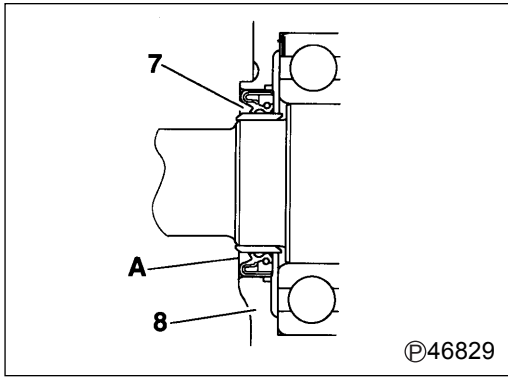

7 Installing oil seal

Face oil seal 7 as shown in the illustration. Then, fit it in bearing holder 8 by pressing evenly until it is flush with the end face A of the holder.

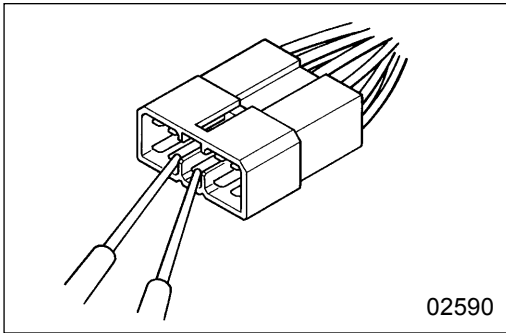

Using male pins

Touch the pins directly using test probes.

CAUTION ⚠

Be sure that you do not short circuit the connector pins when you use the test probe because this could damage the internal circuit of the electronic control unit.

Connector Inspection Procedures

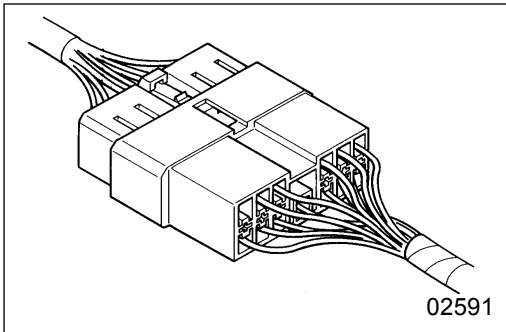

Visual inspection

Check for loose connection and poor engagement.

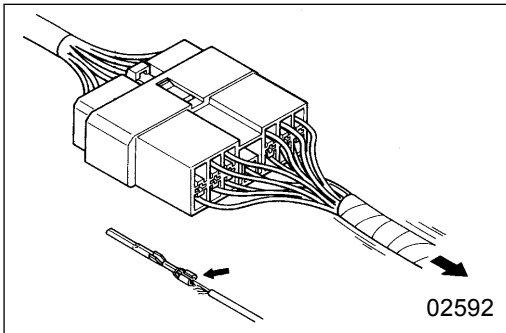

Check if harnesses are broken by pulling gently around the terminals.

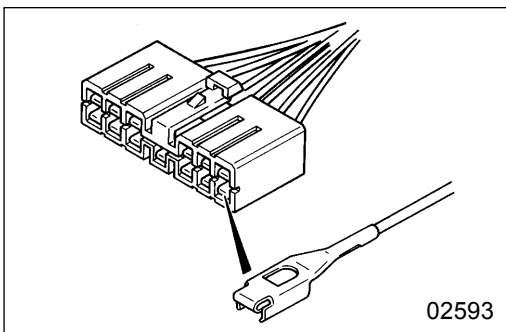

Check for a decrease in contact pressure between the male and female terminals.

Check for poor contact caused by connector pins having fallen out, rusted terminals or foreign particles.

TURBOCHARGER <T04E (6D16-TLE)>

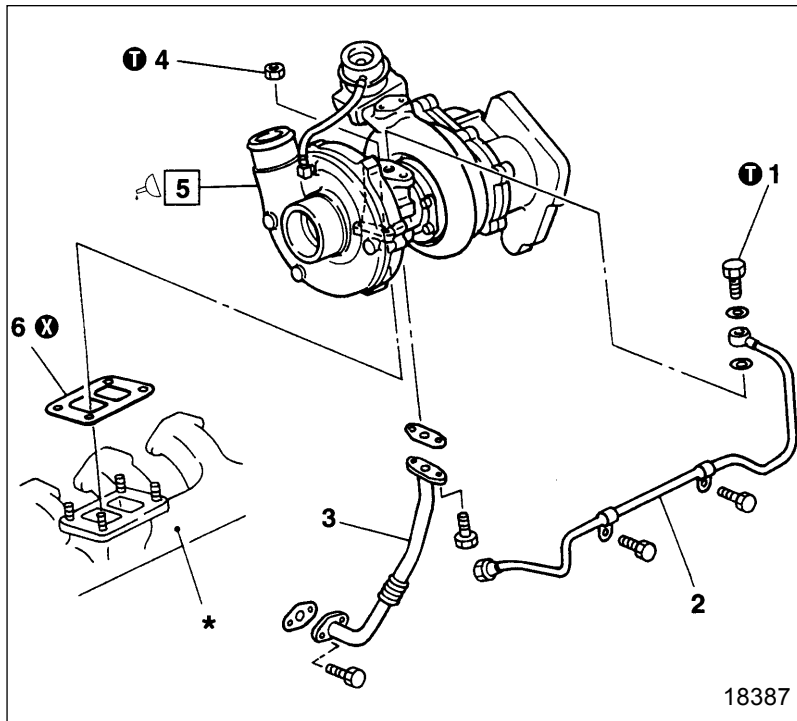

● Removal sequence

- 1 Eyebolt
- 2 Oil inlet pipe
- 3 Oil return pipe
- 4 Nut
- 5 Turbocharger assembly P.15-10
- 6 Gasket

*: Exhaust manifold P.15-26, 27

⊗: Non-reusable part

● Installation sequence

Reverse the order of removal.

ⓘ Tightening torque

Unit: N·m (kgf·m) [lbf·ft]

Location	Parts to be tightened	Tightening torque	Remarks
1	Eyebolt (for mounting oil inlet pipe)	21 (2.1) [15.0]	—
4	Nut (for mounting turbocharger assembly)	41 (4.2) [30.2]	—

Lubricant

Location	Points of application	Specified lubricant	Quantity
5	Supply when installing turbocharger assembly	Engine oil	As required

◆ Service procedure

5 Installation of turbocharger assembly

When the turbocharger assembly 5 is installed, supply engine oil from the oil hole A to make sure that all the parts operate smoothly.

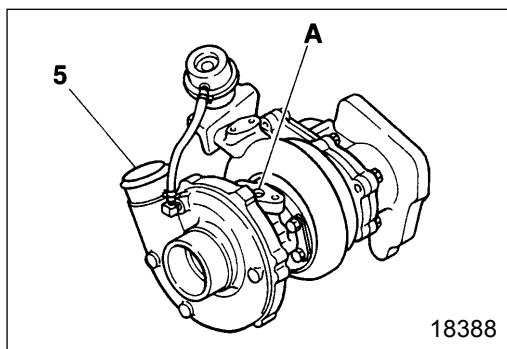

CLICK HERE TO **DOWNLOAD** THE COMPLETE MANUAL

- Thank you very much for reading the preview of the manual.
- You can download the complete manual from: www.heydownloads.com by clicking the link below



- Please note: If there is no response to CLICKING the link, please download this PDF first and then click on it.

CLICK HERE TO **DOWNLOAD** THE COMPLETE MANUAL