

A450

SERVICE MANUAL



www.masai-leisure.com

CLICK HERE TO **DOWNLOAD** THE COMPLETE MANUAL

- Thank you very much for reading the preview of the manual.
- You can download the complete manual from: www.heydownloads.com by clicking the link below



- Please note: If there is no response to CLICKING the link, please download this PDF first and then click on it.

CLICK HERE TO **DOWNLOAD** THE COMPLETE MANUAL



(15) Lubrication

Engine wear is generally at its maximum while the engine is warming up and before all the sliding surfaces have an adequate lubrication film. During assembly, make sure to apply oil to any sliding surface or bearing that has been cleaned. Old grease or dirty oil could have lost its lubrication quality and may contain forging particles that act as abrasives; therefore, make sure to wipe it off and apply fresh grease or oil. Some oils and greases in particular should be used only in certain applications and may be harmful if used in an application for which they are not intended.

(16) Direction of Engine Rotation

To rotate the crankshaft manually, make sure to do so in the direction of positive rotation. Positive rotation is counterclockwise as viewed from the left side of the engine. To carry out proper adjustment, it is furthermore necessary to rotate the engine in the direction of positive rotation as well.

(17) Replacement Parts

When there is a replacement instruction, replace these parts with new ones every time they are removed.

Always replace these parts with new ones every time they are removed. Although the previously mentioned gasket, O-ring, ball bearing, needle bearing, grease seal, oil seal, cir-clip, and cotter pin have not been so designated in their respective text, they are replacement parts.

(18) Electrical Wires

All the electrical wires are either one-color or two-color. A two-color wire is identified first by the primary color and then the stripe color. For example, a yellow wire with thin red stripes is referred to as a “yellow/red” wire; it would be a “red/yellow” wire if the colors were reversed. Unless instructed otherwise, electrical wires must be connected to wires of the same color.

(19) Inspection

When parts have been disassembled, visually inspect these parts for the following conditions or other damage. If there is any doubt as to the condition of them, replace them with new ones.

Abrasion	Crack	Hardening	Warp
Bent	Dent	Scratch	Wear
Color change	Deterioration		Seizure

(20) Specifications

Specification terms are defined as follows:

“Standards” show dimensions or performances which brand-new parts or systems have.

“Service Limits” indicate the usable limits. If the measurement shows excessive wear or deteriorated performance, replace the damaged parts.

Wheel (Rim) Inspection

Examine both sides of the rim for dents [A]. If the rim is dented, replace it.

If the tire is removed, inspect the air sealing surfaces [A] of the rim for scratches or nicks. Smooth the sealing surfaces with fine emery cloth if necessary



Wheel (Rim) Replacement

Remove the wheel (see Wheel Removal)
 Disassemble the tire from the rim (see Tire Removal).
 Remove the air valve and discard it.

CAUTION

Replace the air valve whenever the tire is replaced. Do not reuse the air valve.

Install a new air valve in the new rim.
 Remove the valve cap, lubricate the stem with a soap and water solution, and pull the stem [A] through the rim from the inside out until it snaps into place.



CAUTION

Do not use engine oil or petroleum distillates to lubricate the stem because they will deteriorate the rubber.

Mount the tire on the new rim (see Tire Installation).
 Install the wheel (see Wheel Installation).

TIRES

Tire Removal

Remove the wheel.
 Unscrew the valve core to deflate the tire.
 Use a paper valve core tool [A].
 Lubricate the tire beads and rim flanges on both sides of the wheel with a soap and water solution, or water [A]. This helps the tire beads slip off the rim flanges.



WARNING

Do not attempt to drive the vehicle until a full brake level is obtained by pumping the brake level until the pads are against each disc. The brakes will not function on the first application of the level if this is not done.

Caliper Removal

Removal the front wheel (see Wheels/Tires chapter).
 Loose the banjo bolt [A] at the brake hose lower end, and tighten it loosely.
 Unscrew the caliper mounting bolts [B], and detach the caliper [C] from the disc.
 Unscrew the banjo bolt and remove the brake hose [D] from the caliper.

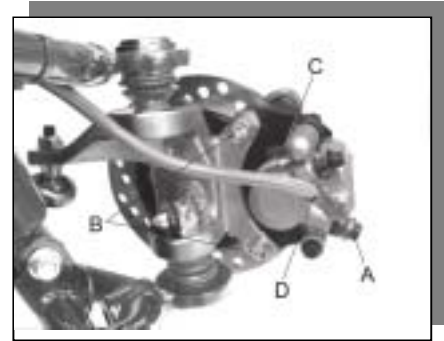

CAUTION

Immediately wash away any brake fluid that spills.

NOTE

If the caliper is to be disassembled after removal and if compressed air is not available, disassemble the caliper before the brake hose is removed (see Caliper Disassembly).

Caliper Installation

Install the caliper and brake hose lower end.
 Replace the washers that are on each side of hose fitting with new ones.
 Tighten:

Torque -Caliper Mounting Bolts:25N-m(2.5kg-m,18.0ft-lb)

Brake Hose Banjo Bolt:25N-m(2.5kg-m,18.0ft-lb)

Check the fluid level in the brake reservoir.
 Bleed the brake line (see Brake Line Air Bleeding).
 Check the brake for good braking power, no brake drag, and no fluid leakage.

WARNING

Do not attempt to drive the vehicle until a full brake level is obtained by pumping the brake level until the pads are against each disc. The brakes will not function on the first application of the level if this is not done.

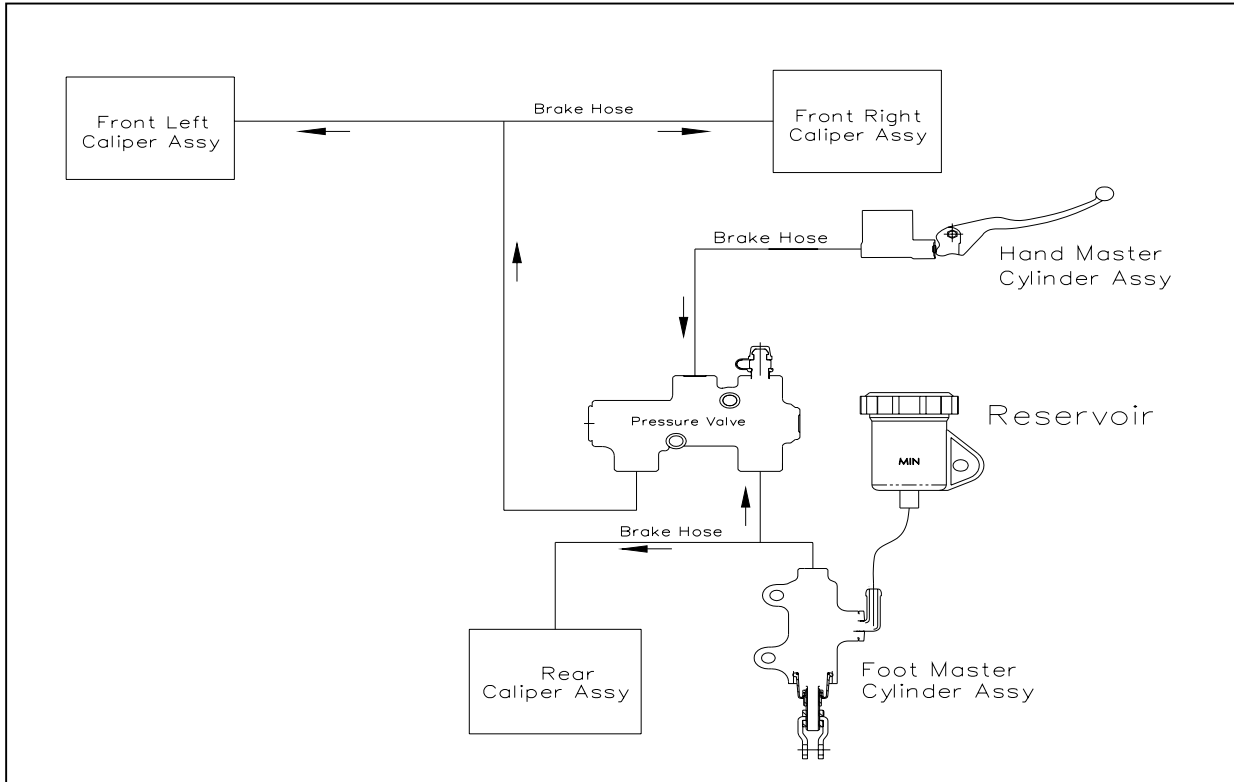
Brake System Scheme

Steering Lubrication

Lubricate the steering stem clamps.

Remove the steering stem (see Steering Stem Removal).

Wipe all the old grease off the steering stem, and clamps, and out of the grease seals.

Apply grease to the steering stem [A], grease seal lips and mating surface [B] of the clamp, and pack the grooves [C] in the clamp with grease.

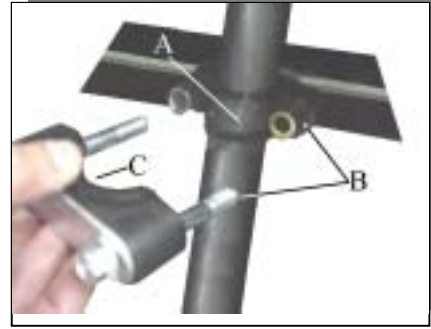

Steering Stem Clamp Inspection

Inspect the steering stem clamps.

If roughness, excessive play, or seizure is found, replace both clamps.



Tie-Rod End and Steering Knuckle Joint Inspection

Inspect each spherical bearing [A].

If roughness, excessive play, or seizure is found, replace the tie-rod end, or steering knuckle joint.

If damage, wear or deterioration is found, replace the tie-rod end.



CLICK HERE TO **DOWNLOAD** THE COMPLETE MANUAL

- Thank you very much for reading the preview of the manual.
- You can download the complete manual from: www.heydownloads.com by clicking the link below



- Please note: If there is no response to CLICKING the link, please download this PDF first and then click on it.

CLICK HERE TO **DOWNLOAD** THE COMPLETE MANUAL

Removal and Installation

Thoroughly clean the ATV engine and chassis.

Clean work area.

Drain coolant and engine oil.

Disassembly

Set the engine assembly onto Special Tool; Engine Base Plate AY.



- Take out Cover CP (Drive Chain) and Plate (Drive Chain).



- Operate Shift Pedal to engage the transmission gears.
Remove bolts and take out Fixing Plate, and then remove Sprocket 14T.
- Remove Shift Pedal.
- Remove Reverse Arm Lever (Reverse Lock).
- Remove Carburetor.
- Remove upper side banjo bolt (oil fitting) first, after that other bolts, and then take out Oil Delivery Pipe Assy.



Note:

Pay attention not to lose total 6 copper washer.

PISTON RINGS

Clearance between Piston Ring and groove

- Remove carbon deposits from Rings and grooves.
- Measure the clearance between Piston Ring and groove, by holding the Ring upwards in the groove, with thickness gauge.

Service Limit of clearance	
Top	0.15 mm
Second	0.15 mm



Piston Ring gap (Opening)

- Insert Piston Ring into the lower portion of Cylinder horizontally by using Piston.
- Measure the Piston Ring gap (opening) with thickness gauge.

Service Limit of Piston Ring gap(Opening)	
Top ring	0.7 mm
Second ring	0.8 mm
Oil ring (side rail)	1.0 mm



CRANKSHAFT

Runout

- Set on the V-block and measure runout with dial gauge.

Crankshaft Runout	
Service Limit	0.06 mm



Side-clearance at large end of Connecting Rod

Measure the side-clearance at large end of Connecting Rod with thickness gauge.

Side-clearance at large end	
Service Limit	0.65 mm



- Apply oil to O-ring and install Starter Motor in position.

Tightening Torque: 9 - 11 N-m

Fastener : M6 X 25L 2 pcs.

- Fit two Pipe Knocks and set Cylinder Gasket.



Assemble and install Piston.

- Set Piston Rings into Piston grooves;
 - Expander Ring into Oil Ring groove
 - Second Ring, facing the marking upwards
 - Top Ring, facing the marking upwards
- Make sure rings are smoothly moved and adjust the openings (gaps) at 120-degree intervals.
- Fit new clip into the groove on one side and make sure of the clip fitting properly in the groove.
- Place Special Tool; Piston Support Plate.



- Insert Piston, with the marking on the top surface faced to magneto side, into cylinder.
- Apply oil to small end hole of Connection Rod, Piston Pin and hole. Then fit Piston Pin into Piston.
- Fit new clip into the groove on another side and make sure the clip fitting properly in the groove.



- Apply oil around Piston and Rings, and cylinder bore.
Install Cylinder by holding Rings by Special Tool; Ring Band.
Make sure of the smooth operation by turning Crankshaft, with Cylinder pressed down by hand.



Attachment (1) Special Tool



7. COVER (CHAIN)

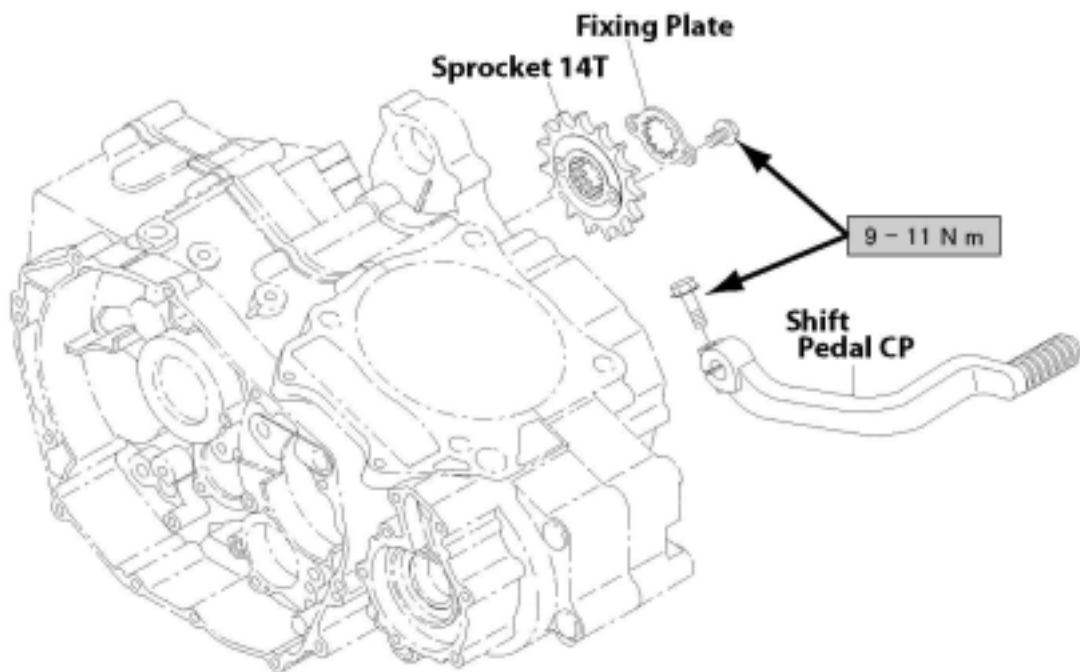

Specifications

Item		Standard	
Battery Capacity		12 V 14Ah,	
Alternator type		Three-phase AC	
Charging voltage (Regulator/rectifier output)		14~15 V	
Alternator output voltage		DC14V-13.7A @ 3000 rpm	
Stator	Charge Coil	Y1-Y2	0.52 Ω
		Y2-Y/R	0.49 Ω
		Y/R-Y1	0.49 Ω
		Y-Ground	
	Pulser Coil	W/R-W	190 Ω
		W-Grnd	
Ignition Coil		Primary	0.3 Ω
		Secondary	6.3 k Ω
Spark plug		Gap	0.9 mm
		Cap resistance	5 k Ω
Starter motor		Nominal Output	0.7 kW
		Reduction Ratio	28.235



Ignition Coil Installation

Connect the primary winding leads to the ignition coil terminals

Ignition Coil Inspection

Remove the ignition coil.

Measure the primary winding resistance [A] as follows:

Connect the tester between the coil terminals.

Set the tester to the $\times 1\Omega$ range, and read the tester.

Measure the secondary winding resistance [B] as follows:

Remove the plug cap by turning it counterclockwise.

Connect the tester between the spark plug lead and terminal.

Set the tester to the $\times 1\text{ k}\Omega$ range, and read the tester.

If the hand tester does not read as specified, replace the coil.

To install the plug cap, turn it clockwise.

CLICK HERE TO **DOWNLOAD** THE COMPLETE MANUAL

- Thank you very much for reading the preview of the manual.
- You can download the complete manual from: www.heydownloads.com by clicking the link below



- Please note: If there is no response to CLICKING the link, please download this PDF first and then click on it.

CLICK HERE TO **DOWNLOAD** THE COMPLETE MANUAL