

MODEL 2650 & 2700
SERIES QUANTUM SERIES
BOOK NO. 815
SERIAL NO. _____

CALIFORNIA

Proposition 65 Warning

Diesel engine exhaust and some of its constituents are known to the State of California to cause cancer, birth defects, and other reproductive harm.

MACHINE SERIAL NUMBER

The machine serial number is stamped on the serial number plate which is located inside the Operator's Cab, to the right of the operator. The serial number is the only means the distributor or factory has of ensuring that the correct parts will be furnished.

In the event that the serial number plate is lost, there is another number stamped on the right hand boom foot mounting lug on the upper revolving frame. On hydraulic cranes and excavators, the number is stamped between and below the boom hoist cylinder mounting lugs. This number, A, B, C, etc., _____ should then be furnished, as this will enable us to determine the machine serial number.

WDL1500-OE

Printed in Japan

CLICK HERE TO **DOWNLOAD** THE COMPLETE MANUAL

- Thank you very much for reading the preview of the manual.
- You can download the complete manual from: www.heydownloads.com by clicking the link below



- Please note: If there is no response to CLICKING the link, please download this PDF first and then click on it.

CLICK HERE TO **DOWNLOAD** THE COMPLETE MANUAL

SAFETY Warning Signs and Labels

Always keep the warning signs and labels in readable condition.

[If they get dirty]

Use water or detergent and remove the dirt. Do not use gasoline or organic solvents. If the dirt cannot be removed, replace the label

When replacing, check to see that the new one is the same as the one being replaced.

[If they are damaged or lost]

Obtain a new one from your local distributor.

When replacing, check to see that the new one is the same as the one being replaced
(Front-window)

NOTICE

WHEN CLEANING THE CAB WINDOWS, USE ONLY MILD DETERGENT, CLEAN WATER AND A SOFT CLOTH. HARSH OR ABRASIVE CLEANERS WILL SCRATCH THE WINDOW.

CAUTION

FALLING WINDOW MAY CAUSE BODILY INJURY. AFTER REMOVING OR REPLACING FRONT WINDOW, ENSURE THAT AUTOLOCK IS ENGAGED AND LOCK WINDOW IN PLACE WITH PINS PROVIDED.

KHP1008-00

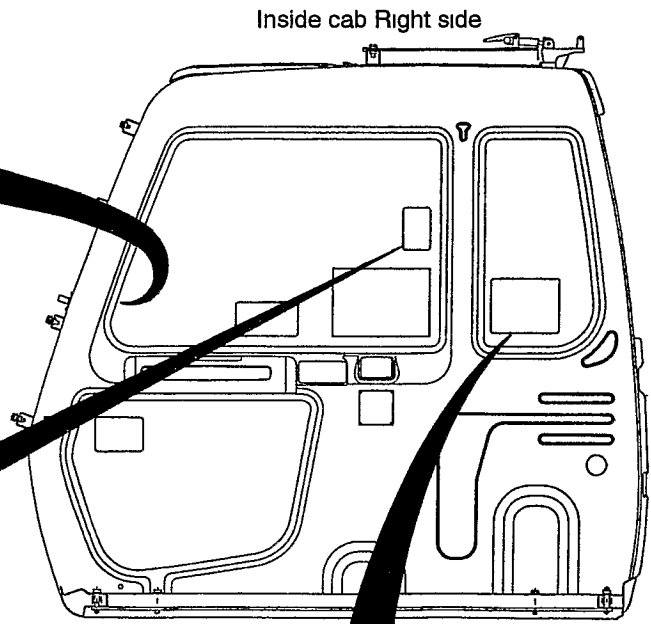

NOTICE

OFF

RAISE LEVER TO SHUT OFF CONTROLS BEFORE LEAVING THE CAB FOR ANY REASON.

KHP1005-00

DANGER

ELECTROCUTION HAZARD.

CONTACT WITH EXCAVATOR OR GROUND MAY CAUSE DEATH OR BODILY INJURY.

KEEP ALL PARTS OF MACHINE AND LOAD AT LEAST 15 FEET (4.57M) AWAY FROM ALL ELECTRICAL POWER LINES OR SUCH DISTANCE AS SPECIFIED BY LOCAL SAFETY CODES.

IMPROPER EXCAVATOR OPERATION AND MAINTENANCE CAN CAUSE INJURY OR DEATH. READ AND STUDY THE OPERATOR'S MANUAL AND ALL SAFETY MESSAGES. LEARN AND PRACTICE SAFE USE OF CONTROLS. OPERATE PROPERLY. INSPECT AND MAINTAIN EXCAVATOR DAILY.

KHP1004-00

SAFETY During Transportation

■ Caution during loading and unloading

- When loading or unloading the machine on the trailer truck, use proper ramps.

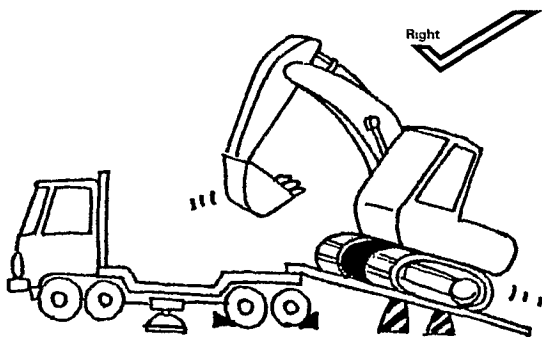

■ Caution during transportation

- Securely fasten the machine to the trailer to prevent it from moving during transportation

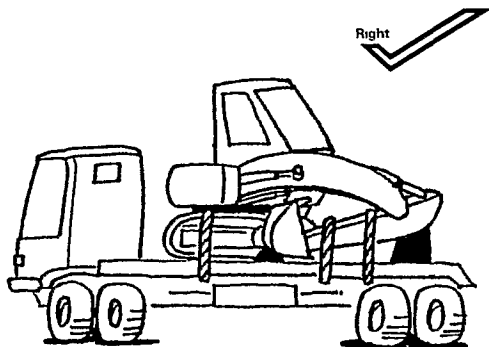

■ Caution during removal of the front attachment

- The center of gravity will shift to the back when the front attachment is removed.
- Take sufficient caution when running the machine

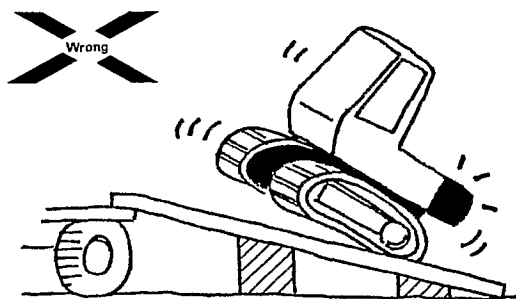

Face the counterweight towards the upper side of the slope when running the machine without the front attachment

Before Inspection and Maintenance

■ Understand the inspection and maintenance method

- Read and understand the section on Inspection and Maintenance before carrying it out.

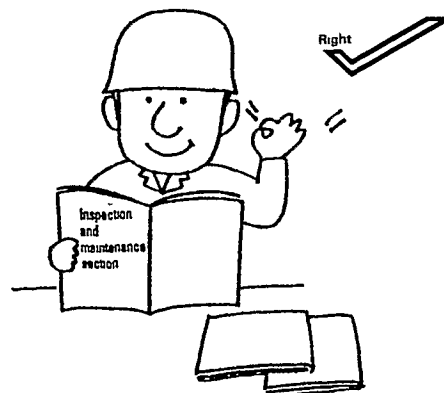

■ Carry out on level ground

1. Select an area which has flat, hard ground and is safe
2. Lower the bucket to the ground
3. Stop the engine and remove the key
4. Block both tracks

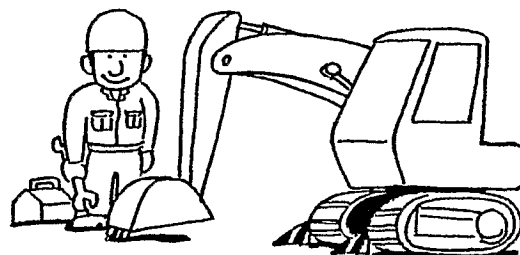

■ Put up an "Under Inspection" sign

- Hang the "Under Inspection" notice plate on the cab door or on the operation levers

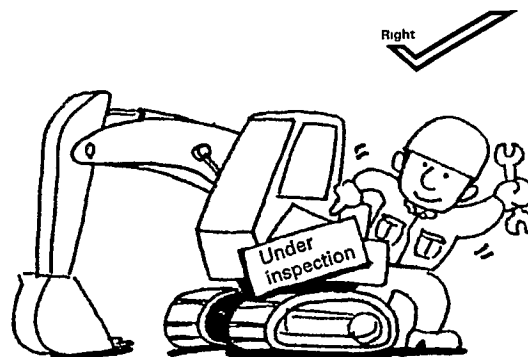

OPERATION Instruments and Controls

One Touch/Auto Change Switch

One Touch (When switch lamp is on)

When the idle switch is pressed the engine revolutions can be put in low idling. (When the engine is started, it is in one touch.)

Auto (When the switch lamp is off)

With the operation lever in neutral (interrupting work temporarily), after about 15 seconds the engine revolutions automatically go into low idling. Also, if the idle switch is pressed, low idling can be obtained



Idle Switch (One Touch Idle Switch)

By pressing this switch, the engine r p m can be switched back and forth between low idling and the original r.p.m amount with each push of the switch. When it is in low idling, the message "ENG IDLING" is indicated

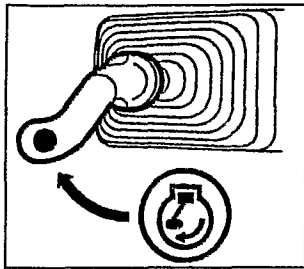

Work Lamp Switch

The switch to turn on and off the work lamp

Switch Lamp	Work Lamp
Off	All Off
○ 1 On	House Light On Only
○ 2 On	House and Boom Light On

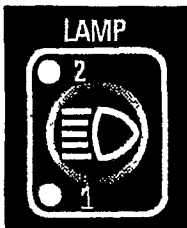

Wiper Switch

The switch that controls the windshield wiper

Switch Lamp	Wiper Function
Off	Stop
○ INT	Works intermittent
○ CONT	Works continuously

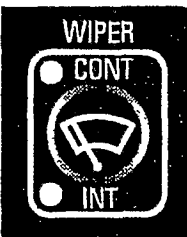

◆ Using the wipers when the windshield is dry or when it is soiled with dirt or with snow can cause damage to them. Use caution in such cases.

Washer Switch

The switch that controls the spraying of washer fluid. Washer fluid is sprayed and the wipers move as long as the switch is pressed

◆ Do not press when there is no washer fluid or the motor may seize.

• The washer fluid tank is located in the tool box in front of the fuel tank



Work Mode Selection Switch

The switch to choose the movement and strength of the machine suitable to the work contents and purpose. The mode chosen is indicated

• When the engine is

started, the standard mode is indicated.

H: HEAVY MODE

For heavy digging or when increase in the work load is desired

S: STANDARD MODE

For standard digging and loading work

L: LIGHT MODE

For accurate and safe lifting work rather than greater speeds

F: FINE MODE

For slow, precise controlled operation

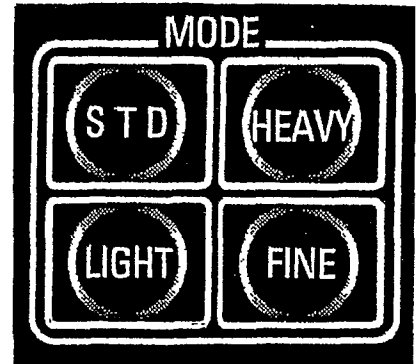

Cushion Switch

The switch to choose the attachment stopping condition

• When the engine is started, the machine is in cushion

Switch Lamp	Stopping Condition
Lamp Off	Cushioned
○ Lamp on	Cushion is off

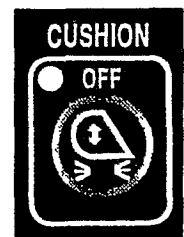

Travel Caution Alarm Switch

"ON" position the alarm sounds when the travel controls are actuated

"AUTO OFF" position, when the travel controls are actuated, the alarm sounds for 15 seconds and then stops. Each time you stop the travel and then start again the alarm will sound for 15 seconds and then stop.

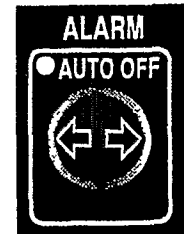

OPERATOR'S CAB

Front Window

WARNING

When opening and closing the front window,

- ① On a level site, lower the bucket to the ground and stop the engine.
- ② When opening and closing the window, do it slowly with care to prevent getting fingers or hands caught.
- ③ Securely lock the window in place before working.

1 Upper Window

The front window (upper window) can be stored in the top of the operator's cab

Opening

- 1 Disconnect the wiper motor cable at the plug ① and secure it with a clip it so it doesn't get tangled

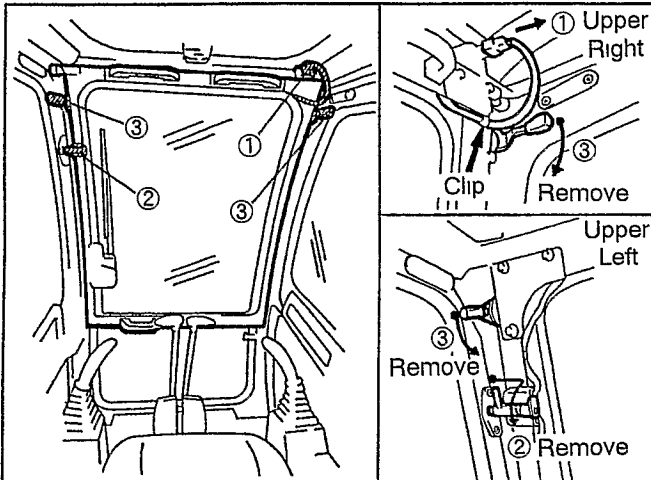

2. Turn the lock pin ② inward located at the upper left of the front window and secure it with the lock released. (upper figure)
- 3 Lower the left and right autolock ③ located at the upper side of the window and release the lock.

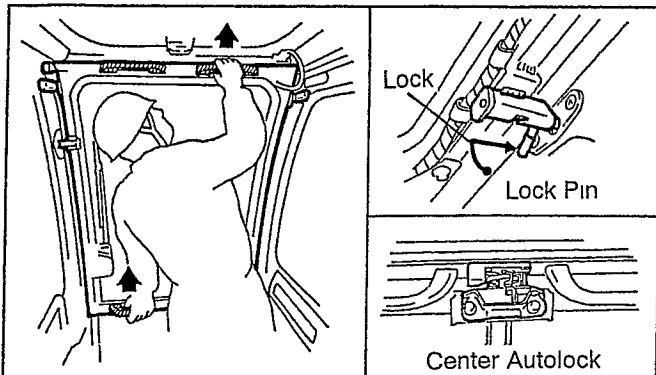

- 4 Hold the lower grip with the left hand and the upper grip with the right hand. Slowly pull up the front window. After verifying that the window is fixed by the center autolock located at the rear top of the cab, securely lock the window with the lock pin (upper figure)

Closing

1. 1) Turn the lock pin inward to release the lock at the back side of the cab
- 2) Remove the autolock at the upper side of the back of the cab
2. Grab the front window side grip with the left hand and the rear window side grip with the right hand
- 3 Slowly lower the front window
- 4 After verifying that the autolock on the left and right above the front window are locked, lock the window with the left side lock pin
5. Connect the wiper motor cable

CAUTION

FALLING WINDOW MAY CAUSE BODILY INJURY. AFTER REMOVING OR REPLACING FRONT WINDOW, ENSURE THAT AUTOLOCK IS ENGAGED AND LOCK WINDOW IN PLACE WITH PINS PROVIDED.

2 Lower Window

When the upper window of the front window is opened, the lower window can be removed

1. Remove the left and right lock pins ① of the lower window and the lower window of the front window is ready for removal

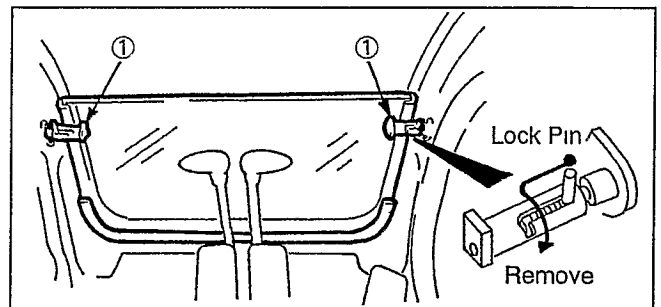

- 2 Store the removed lower window of the front window into the rear window.

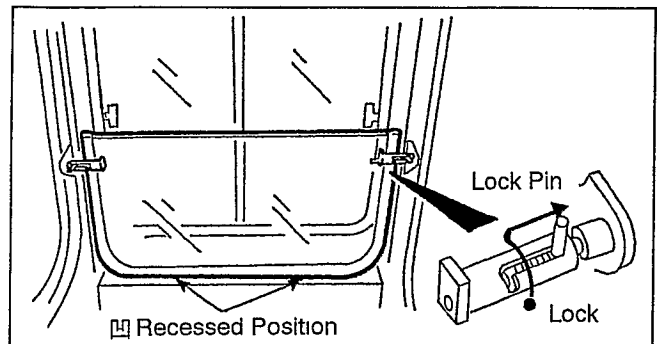

- ① For storage, align the projecting area of the lower window with the recess area of the storage position
- ② Securely lock the left and right lock pins.

[OPERATING INSTRUCTIONS]

The **[OPERATING INSTRUCTIONS]** section describes the proper operation of the machine.

All operators should always operate the machine carefully and safely to prevent injury to themselves and others and to prevent damage to the machine.

CONTENTS

- Operation of new machine
- Daily inspection
- Starting and stopping the engine
- Warm up operation
- Work Modes
- Operations (Traveling)
(Swing)
(Attachment)
- Bucket turning over and replacement
- On completion of daily operations
- Operating in cold climates
- Operating under extreme conditions
- Special attachments
- Transportation
- Storage

**OPERATING
INSTRUCTIONS**

NOTE. For operation of the instruments and controls, refer to the **[OPERATION]** section

⚠ WARNING

If any problem is found on the machine, immediately correct the problem.

Do not run or operate any machine which is not properly maintained.

Before beginning operations, check the job site conditions and take the necessary measures to insure safe operations.

- Use extreme care in dangerous places.
- Make sure that unauthorized people cannot enter the job site.

OPERATING INSTRUCTIONS **Traveling**

■ Pulling out from soft ground

(On soft ground, take care to prevent the machine from sinking.)

If the machine cannot travel because the bottom comes into contact with soft ground or the track becomes filled with mud or gravel, push the boom and arm on the ground to clear one track from the ground. When the machine is raised on one side, alternately run the track forward and backward to remove the mud and gravel. Perform this for each track.

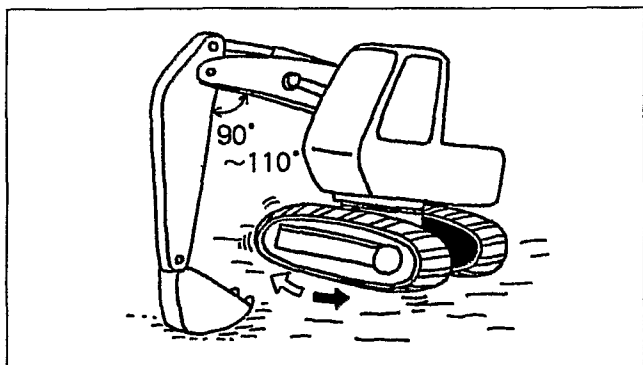

- ◆ When raising the machine with the boom and arm, press the bottom of the bucket against the ground. Keep the angle between the boom and arm between 90° and 110°. This also applies to the shovel.

Only one side

If only one side of the machine sinks, press the bucket against the ground on the low side to raise the track. Then place a log or board, etc. under the shoe and pull the machine out.

Both sides

If both sides sink, place logs or boards, etc. under both tracks in the same manner as above. Press the bucket into the ground in front of the machine and fold the arm in the same manner as when digging. Then operate the travel levers to pull the machine out.

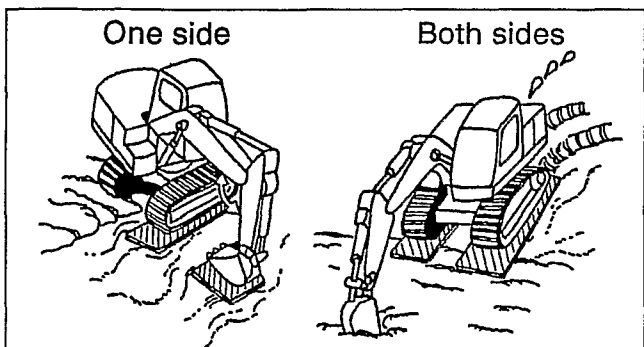

▲ Cautions for operation at the allowable water depth or on soft ground

Allowable water depth	Machine Type	2650/2700
	A measurement (mm)	25 inches (650)

Water up to the upper roller is allowable.

- 1 Before moving the machine into the water for operations, check the water depth. **“Water up to the upper roller is allowable.”**
2. On soft ground, the machine may sink gradually during excavation operations. Take care that it doesn't sink too much.

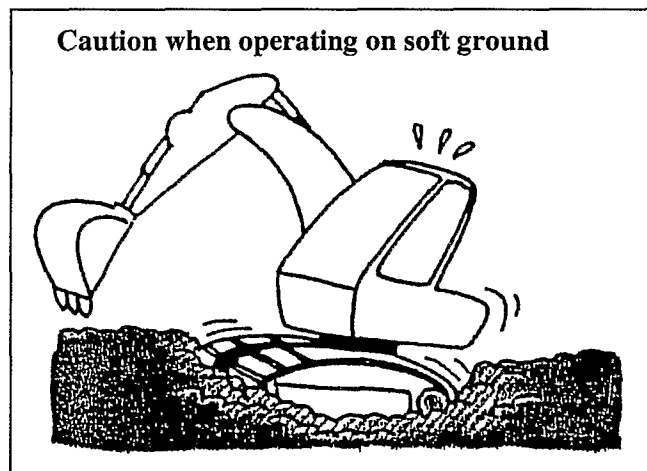



- 3 **If the machine sinks in water or soil up to the swing body, grease replacement and maintenance is necessary.** Stop operations and perform the necessary maintenance.
- 4 After operating the machine in water or on soft ground, grease the attachment and turntable bearing. Clean and check the crawler.

ENDING WORK

1 Parking the Machine

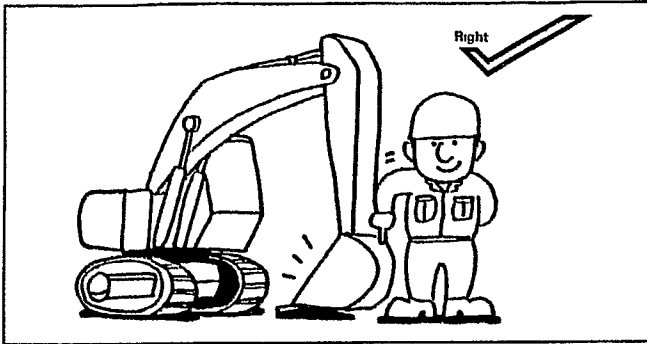
- 1) Stop the machine on level and solid ground which is free from the danger of falling rocks or standing water.
- 2) Press the SWING BRAKE switch so that the mark  is displayed.
- 3) Position the arm vertically and lower the bucket to the ground.



- 4) Press the CONTROL OFF switch so that the mark  is displayed on the monitor.
- 5) Idle the engine at low speed for about 5 minutes and cool down the engine.
- 6) **Stop the engine and remove the key.**
- 7) Close the windows and raise the left console box and gate lock.
- 8) **Lock the cab door** to prevent unauthorized persons from entering the machine.

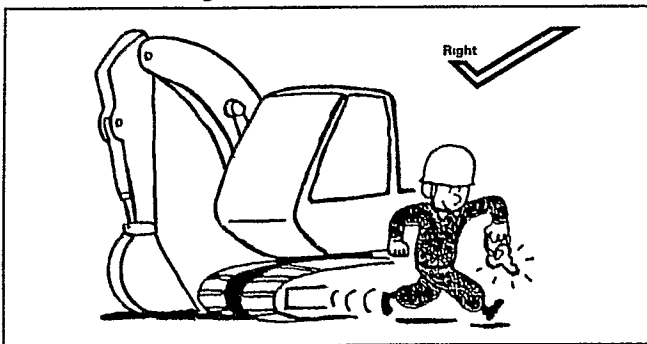

CAUTION

When parking the machine on a road, provide signs and barricades which make the machine clearly visible for passing vehicles especially at night.

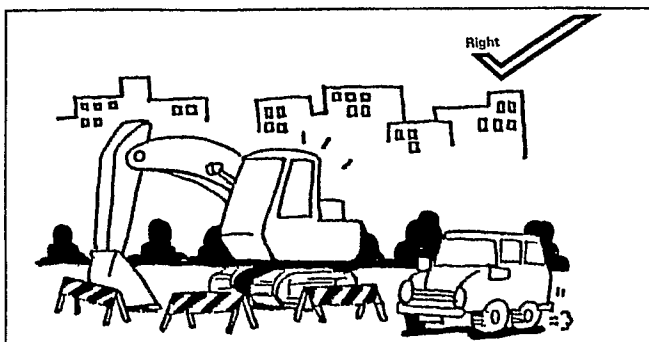

2 Inspection after Finishing Operations

1) Cleaning and Inspection

Check each area for oil and water leakage and any damage.

Also wash the machine as part of the inspection. In particular, clean the crawler of dirt and sand **(Prevent water from getting on the electrical parts.)**

2) Refilling Fuel Tank

Stop the engine and refill the fuel tank.

When refilling, take care to prevent dust or water from getting into the fuel tank.

WARNING

Do not have flames near by while refueling.

- When it is cold (Outside temperature is less than +32°F (0° C)), drain the water which has collected in the fuel system (fuel tank and water separator) to prevent freezing.

[Wipe off any spilled fuel.]

After operations are finished, inspect each area of the machine (including washing the machine)

- **If any problem is found, correct it immediately.**
- **After ending work each day, refill the fuel tank to reduce condensation of water in the tank.**

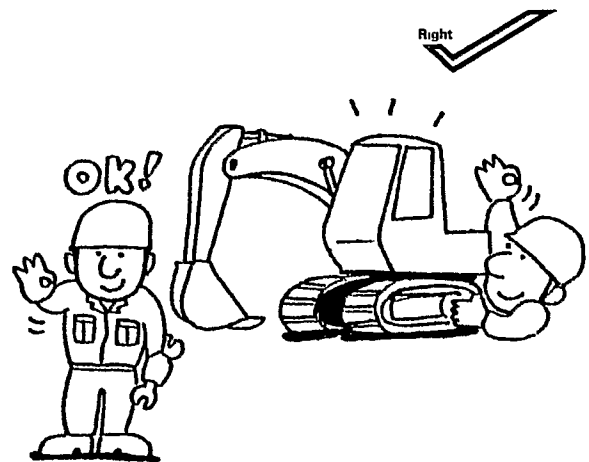

Especially after working in a sandy, dusty site, very cold or hot site or wet or soft ground, carefully inspect each area of the machine and perform the necessary maintenance.

CLICK HERE TO **DOWNLOAD** THE COMPLETE MANUAL

- Thank you very much for reading the preview of the manual.
- You can download the complete manual from: www.heydownloads.com by clicking the link below



- Please note: If there is no response to CLICKING the link, please download this PDF first and then click on it.

CLICK HERE TO **DOWNLOAD** THE COMPLETE MANUAL

OPERATING INSTRUCTIONS Hoisting Loads

For lifting and loading work, follow all applicable laws and regulations in the area.

Precautions for lifting loads with the hydraulic excavator.

CAUTION

■ Make plans for about the work

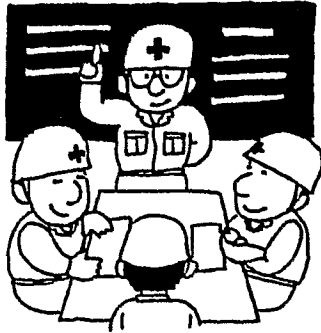

- 1 Only carry out such operations when it is unavoidable and when such work is necessary for safety reasons
- 2 The operator and other workers must have sufficient knowledge of the job to be performed
- 3 The slings must be of sufficient strength and have a slip prevention device so that there is no danger of the load falling off.

Take measures to carry out safe operations.

① Decide on the signals to be used during lifting operations and the signalman who is to give the signals.

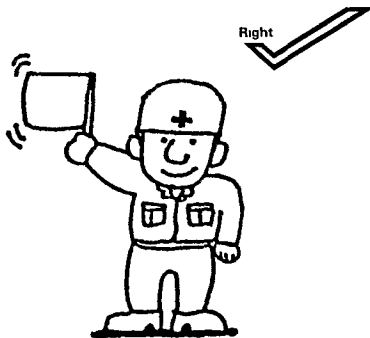

② Carry out the work on level ground (There is danger of turning over if done on a slope)

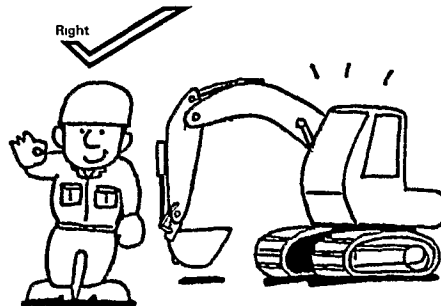

③ Level the footing on a slope before beginning work.

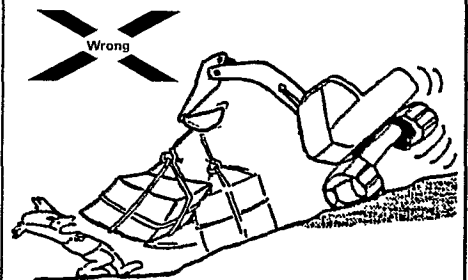

④ Do not allow anyone under the load or other dangerous places

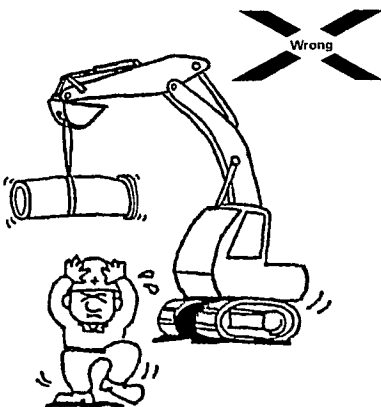

⑤ Do not lift a load which exceeds the rated capacity.

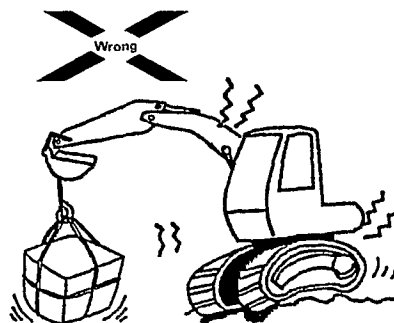

⑥ Use wire ropes and slings which are of sufficient strength and which are not deformed or corroded

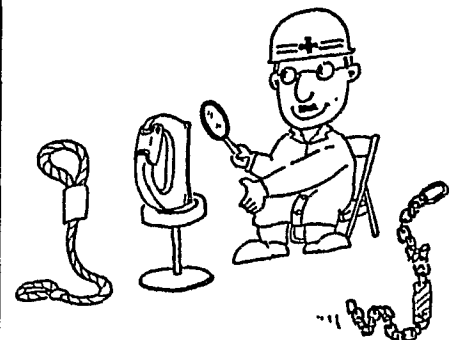

Safety factor of the wire rope should be greater than 6
Safety factor of the slings should be greater than 5

■ The machine is very hot just after stopping the engine!

- All parts of the machine may be very hot just after the engine is stopped. You may get burned if you touch them.
- Wait until the machine has cooled down before beginning inspection and maintenance

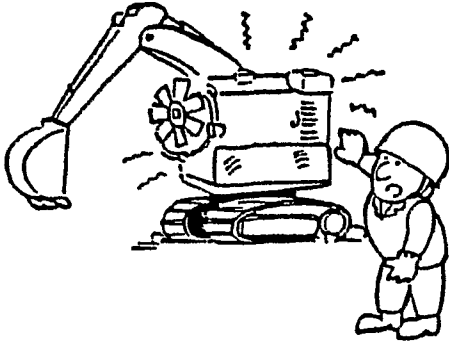

■ Maintenance under the machine.

- When working under the machine, securely support the crawler with safety blocks and supports.

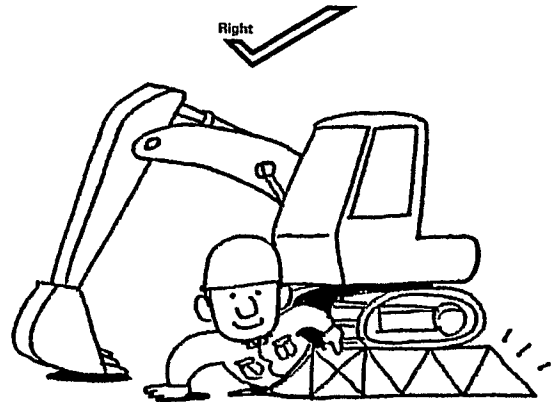

■ Release hydraulic pressure before beginning maintenance.

- After the machine has cooled, release the air and hydraulic pressure before beginning inspection and maintenance.



When maintaining the electrical system, remove the Negative (-) terminal of the battery before beginning.

■ Caution during maintenance at an elevated position.

- Clear the area around the machine
 - * Don't spill oil, grease, etc or scatter tools Be careful of slipping when walking
- Use a ladder and handrails when climbing up and down to the high positions
 - * Never jump on or off the machine

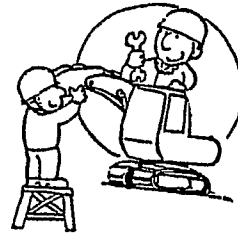

Determine the signals to be used in the joint work and obey the instructions given by the leader.

■ Attachment repair.

- It is dangerous to replace or repair any connections, hoses, etc of the attachment with it in the air. Lower the attachment to the ground or properly block it before making repairs

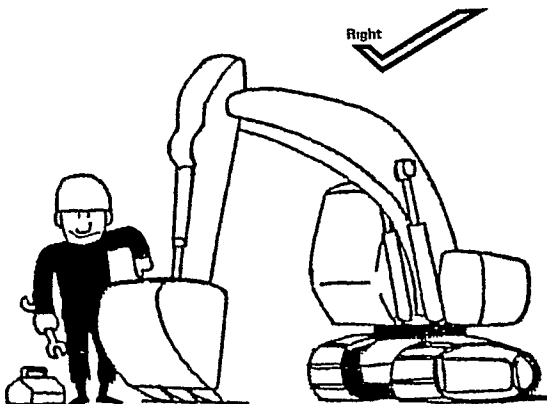

■ Caution about ventilation

- During maintenance indoors or in a poorly ventilated area, open the windows and/or doors for ventilation to prevent gas poisoning

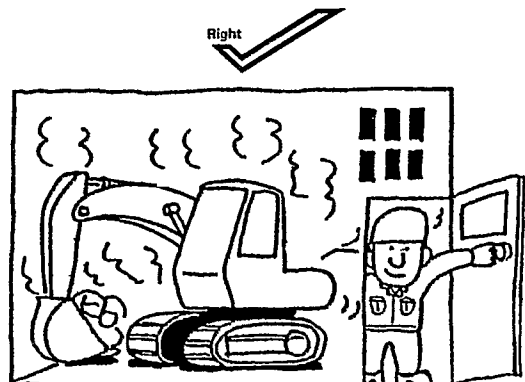

Daily Check-Up

4. Upper Structure

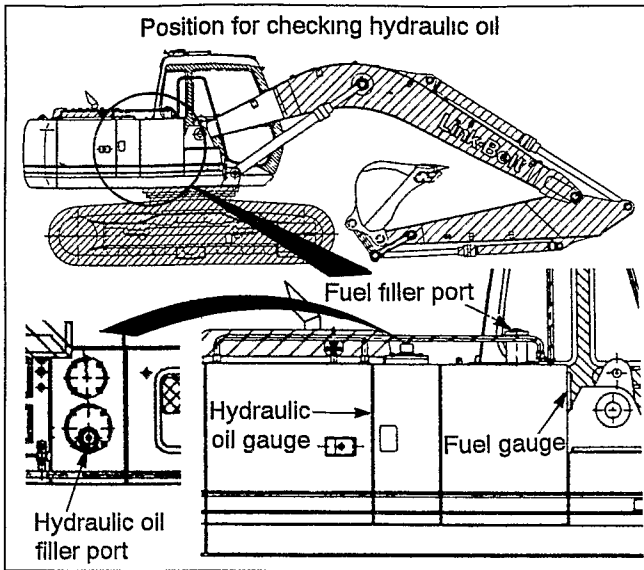

1) Fuel level check

Check the fuel level by the fuel gauge located on the side of the tank and the monitor display. If low, refill through the fuel filler port.

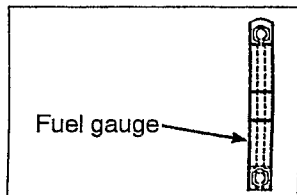

(Refill the tank at the end of each work day to reduce water condensation in the tank)

2) Hydraulic oil level check and refilling

To check the hydraulic oil level, position the machine on level ground and position the attachment as above.

- Check to see that the hydraulic oil level is near the center of the level gauge. If low, remove the filler port cover and refill.
- Take care to prevent contaminants from entering the hydraulic oil when refilling.

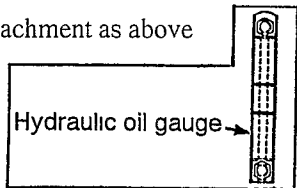

- 3) Check the mounting bolts of the fuel and hydraulic oil tanks for **looseness** and for fuel and hydraulic oil **leakage**.
- 4) Check the mounting bolts of the electrical parts and battery for **looseness** and the **wires for breakage**.

5. Crawler

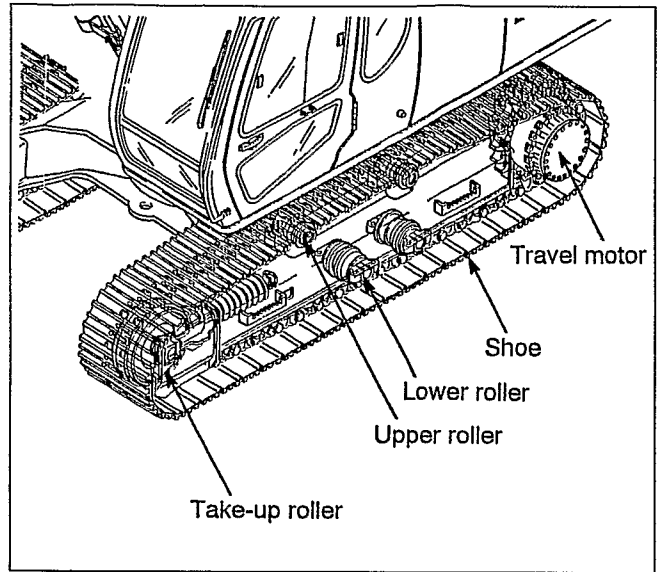

- 1) Check the shoes for looseness, wear and breakage.
- 2) Check the travel motor, upper/lower rollers and take-up roller for oil leakage and wear.
- 3) Check each mounting bolt for looseness or missing bolts.

6. Attachment (Work mechanism)

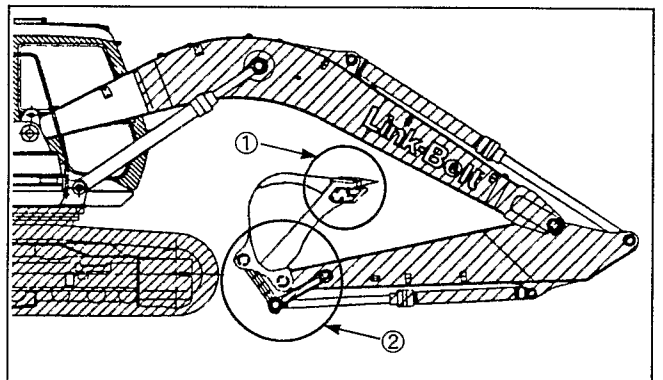

- 1) Check the high-pressure hoses/joints and the hydraulic cylinders for oil leakage.
- 2) **Bucket and linkage**
 - ① Check the bucket teeth and side cutter for looseness, wear and breakage.
 - ② Check the lubrication of the linkage and surrounding parts. Check to see if the bucket backlash is within allowable range (Refer to the Bucket section for backlash adjustment).

**Bolt and Nut torque
【After The First 50 Hours】
【Maintenance interval: Every 250 Hours】**

Tighten the bolts and nuts according to the table After daily work, check the bolts and nuts for looseness and for any missing parts Tighten if loose and replace if missing

Tighten the bolts and nuts after the first 50 hours of operation and every 250 hours thereafter

■ Tightening Torque Table

NOTE: 2560/2700					
No	Tightening Point	Bolt Diameter	Wrench	Tightening Torque	
				[ft•lbs]	[N•m]
①	Travel Motor	M16	24mm	200~230	266 6~311 6
②	Drive Sprocket	M16	24mm	200~230	266 6~311 6
③	Take-up Roller	M16	24mm	200~230	266 6~311.6
④	Upper (Carrier) Roller	M16/M20	24mm/30mm	200~230/385~450	266 6~311 6/520~608
⑤	Lower (Track) Roller	M16	24mm	200~230	266 6~311.6
⑥	Track Guard	M16	24mm	200~230	266 6~311 6
7	Shoe Bolt	M16	24mm	275~330/570~650	372 4~450/760~930
8	Counterweight	M27	41mm	622~723/690~790	842 8~980 0/941~1070
⑨	Turntable Bearing (Lower Frame)	M16/M20	24mm	205~230/350~400	280 3~311 6/475~550
⑩	Turntable Bearing (Swing Frame)	M16/M20	24mm	205~230/350~400	280 3~311 6/475~550
⑪	Swing Equipment	M16/M20	24mm	205~230/390~440	264 6~311 6/530~600
⑫	Engine (Engine Mount)	M16	24mm	195~230	264 6~313 6
⑬	Engine Bracket	M10	17mm	47~55	64 7~75 5
14	Radiator	M12	19mm	45~52	60 8~70 6
⑮	Hydraulic Pump	M10	17mm	47~55	64 7~75 5
⑯	Oil Tank	M16	24mm	152~210	205 8~289.1
⑰	Fuel Tank	M16	24mm	162~210	223 4~289 1
⑱	Control Valve	M16	24mm	200~230	266 6~311.6
⑲	Rotating Joint	M12	19mm	80~94	108 8~126.4
20	Cab	M16	24mm	94~101	127 4~137 2
21	Battery	M10	17mm	15~21	19 6~29 4

Note: Use loctite #262 (adhesive) on those marked (Ⓝ) and tighten to the torque listed in the above table.

The tightening torque for the bolts and nuts not listed above are as follows

Bolt Diameter (size)			M6	M8	M10	M12	M14	M16	M18	M20
Hex bolt	Wrench	[mm]	10	13	17	19	22	24	27	30
	Tightening Torque	[ft•lbs]	5	12	24	43	72	101	145	203
		[N•m]	6.9	15.7	32.3	58.8	98.0	137.2	196.0	274.4
Hex socket head bolt	Wrench	[mm]	5	6	8	10	12	14	14	17
	Tightening Torque	[ft•lbs]	6.5	16	31	58	87	130	180	253
		[N•m]	8.8	21.6	42.1	78.4	117.6	176.4	245.0	343.0

⚠ WARNING

Before inspecting or handling the battery, be sure to turn off the power (turn the starter switch to OFF).

- **The battery generates inflammable, poison gas which can catch fire and explode.**
Never use any open flames or generate sparks near the battery.
- **Dilute sulfuric acid is used in the battery solution. Take sufficient care during inspection or handling.**
- If the electrolyte comes into contact with your skin or clothes, immediately rinse them with water and wash well with soap. If it should get into your eyes, immediately wash them with lots of clean water and see a doctor for medical treatment.

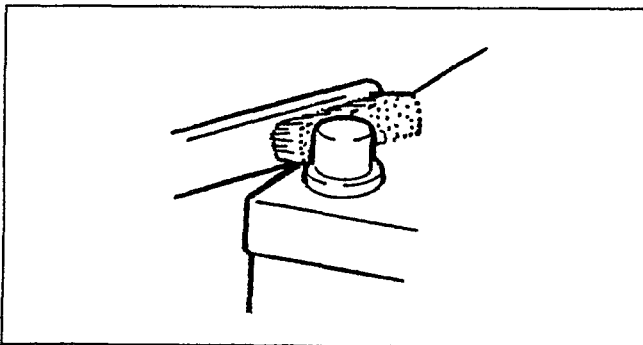
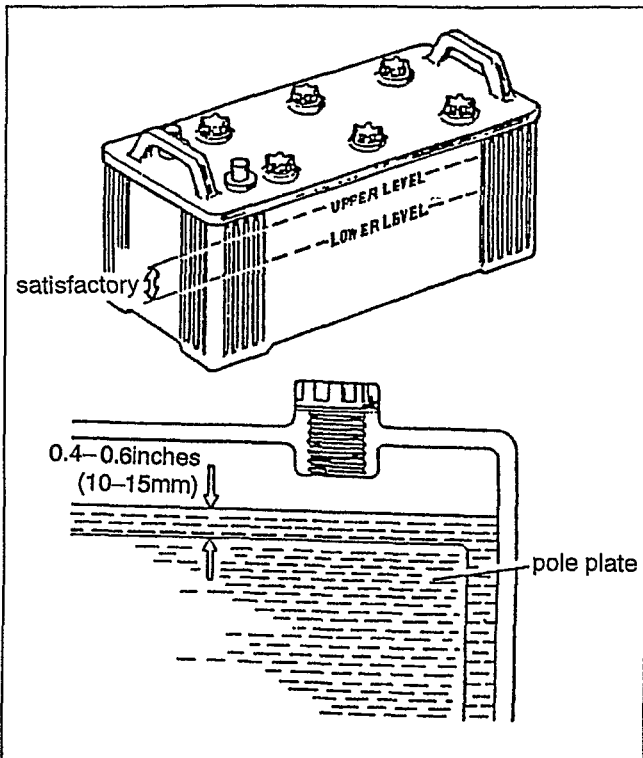

**Battery Inspection and Refilling
【 Maintenance Interval: Every 250 hours】**

- 1) If the solution level is between the UPPER and LOWER levels or if it is 0.4-0.6 inches (10-15mm) above the pole plate, it is satisfactory.
 - 2) If the level is low, remove the cap and refill with solution or distilled water.
- **Don't refill the solution above the UPPER level line or 0.6inch (15mm) above the pole plate.**
 - **Refill before charging (working).**

■ Battery Cable Disconnection

Always disconnect the ground side negative ⊖ terminal first. For connection, connect the ground side negative ⊖ terminal last.

■ Battery Terminal Cleaning

- 1) If the terminal is dirty, clean it. If it is corroded and generates white powder, wash the terminal with hot water. If it is considerably corroded, clean it with a wire brush or sand paper.
- 2) After cleaning, apply a thin coat of corrosion inhibitor on the terminal.

■ Specific Gravity of Electrolyte

Measure the charge rate of the battery with a battery tester or specific gravity gauge. Specific gravity varies with the temperature.

Referring to the table on the left, check the charge rate. Measure the specific gravity of the battery with a specific gravity gauge.

■ Replacing the Battery

When replacing a battery, don't mix using old and new batteries together. (The service life of the new battery will be shortened.)

Charge Rate Depending on the Battery Specific Gravity

Temperature \ Charge Rate	68°F (20°C)	32°F (0°C)	14°F (-10°C)
100% (satisfactory)	1.26	1.27	1.28
90% (satisfactory)	1.24	1.25	1.26
80% (charge)	1.22	1.23	1.24
75% (charge)	1.21	1.22	1.23

If the battery is charged and the charge rate is less than 75%, replace the battery.



Routinely replace important safety parts listed in the charts below.

It is difficult to determine (by visual inspection or from operations) the service life of these parts, so routinely replace them every 2 years.

■ Safety Parts Chart

• Fuel System

Routine Replacement Safety Parts	Replacement Interval
Fuel Hose (Fuel Tank to Engine)	Every 2 years or every 4000 hours, whichever comes first
Fuel Hose (Fuel Filter to Injection Pump)	

• Hydraulic System

Routine Replacement Safety Parts	Replacement Interval
Pump Exit Hose (Pump to Operation Valve)	Every 2 years or every 4000 hours, whichever comes first

Routine Replacement Safety Parts	Replacement Interval
Boom Cylinder Hose	Every 2 year or every 4000 hours, whichever comes first
Arm Cylinder Hose	
Bucket Cylinder Hose	

If any problem is found with any of these parts before the replacement interval, repair or replace as required.

Regarding the hoses, if any deformation, cracks, deterioration, etc. is found with the hose clamps, replace the clamps at the same time as the hoses

Regarding hydraulic hoses not included in the routine replacement safety parts, carry out the inspection described below and retighten, replace, etc. when any problem is found.

★ Replace O-rings and gaskets at the same time as hoses

★ Contact the distributor for replacement of safety parts if required

★ Carry out inspection of the hydraulic hoses and fuel hoses at the routine inspection listed below.

Inspection Classification	Inspection Item
Start-Up Inspection	• Fuel, Hydraulic hose connections, Oil Leakage
Special Independent Inspection (Monthly Inspection)	• Fuel, Hydraulic hose connections, Oil Leakage • Fuel, Hydraulic hose damage (cracks, wear)
Special Independent Inspection (Yearly Inspection)	• Fuel, Hydraulic hose connections, Oil Leakage • Fuel, Hydraulic hose interference, squeezing, aging, twisting, damage (cracks, wear)

SPECIFICATIONS Main Specifications

WORK RANGE 2650 9' 10" (3.0m) ARM

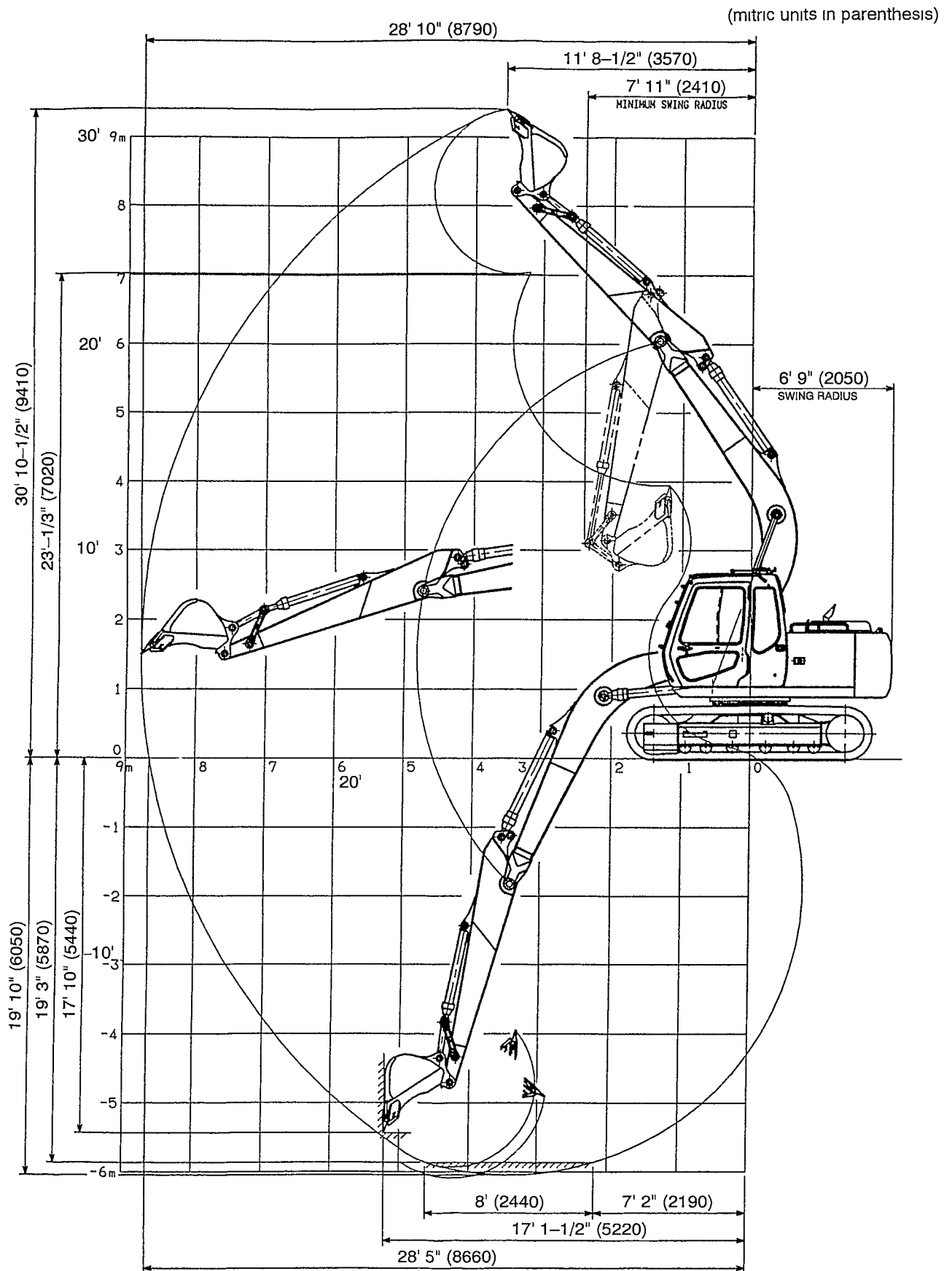

SPECIFICATIONS Pressure Measurement and Adjustment

(d) Pressure Adjustment Point

1) Control Valve

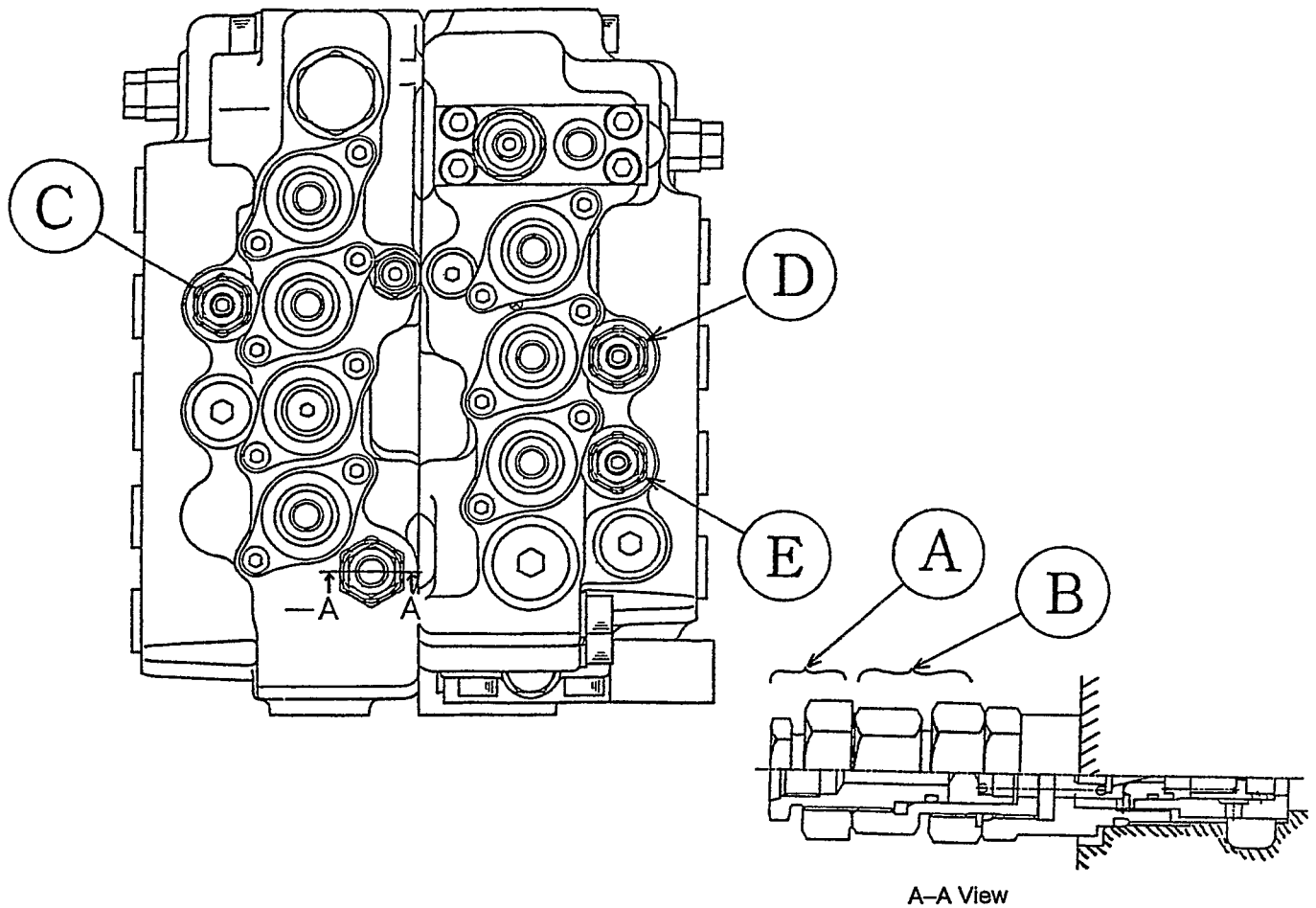

	Front side	Rear side	Measurement port	Tools		Set pressure	For one turn of adjusting screw
				Locknut	Adjusting		
A	Main (Standard)	—	P2g (P1g)	30	22	4550PSI (320kgf/cm ²)	3100PSI (185kgf/cm ²)
B	Main (Power up)	—	P2g (P1g)	30	27	4970PSI (350kgf/cm ²)	
C	Arm (Out)	Arm (In)	P2g	19	HEX Key Wrench 6mm	5200PSI (370kgf/cm ²) For boom down 4100PSI (290kgf/cm ²)	3050PSI (200kgf/cm ²)
D	Bucket (Out)	Bucket (In)	P1g				
E	Boom (Down)	Boom (Up)	P1g				

CLICK HERE TO **DOWNLOAD** THE COMPLETE MANUAL

- Thank you very much for reading the preview of the manual.
- You can download the complete manual from: www.heydownloads.com by clicking the link below



- Please note: If there is no response to CLICKING the link, please download this PDF first and then click on it.

CLICK HERE TO **DOWNLOAD** THE COMPLETE MANUAL