

en

Service manual

Wheel loader

Document ID

Order number: 11835201
Issued: 01-2020
Version: 20
Author: LBH / Technical Documentation Department

Product ID

Manufacturer: Liebherr-Werk Bischofshofen GmbH
Valid for: L 580-1464

Contact

Liebherr-Werk Bischofshofen GmbH
Dr. Hans Liebherr-Straße 4
A – 5500 Bischofshofen

CLICK HERE TO **DOWNLOAD** THE COMPLETE MANUAL

- Thank you very much for reading the preview of the manual.
- You can download the complete manual from: www.heydownloads.com by clicking the link below



- Please note: If there is no response to **CLICKING** the link, please download this PDF first and then click on it.

CLICK HERE TO **DOWNLOAD** THE COMPLETE MANUAL

020.11.1.4	Timber grabber	020-43
020.12	Working attachment	020-44
020.12.1	Quick coupler locking hydraulic cylinder <i>L580-1464;</i>	020-44
020.13	Operator's cab, heating and air conditioning	020-45
020.13.1.1	Air conditioning compressor	020-45
020.13.2	Air conditioning pressure switch <i>L580-1464;</i>	020-45
020.14	Lubrication system	020-46
020.14.1	Central lubrication system (Liebherr) <i>L580-1464;</i>	020-46
020.14.1.1	Central lubrication pump	020-46
020.14.1.2	Progressive distributor	020-46
020.14.2	Progressive distributor <i>L580-1464;</i>	020-47
020.14.2.1	MX-F	020-47
020.14.2.2	MX-F 25	020-47
020.14.2.3	MX-F 45	020-48
020.14.2.4	MX-F 75	020-48
020.14.2.5	MX-F105	020-48
020.14.3	Progressive distributor SXE-2 <i>L580-1464;</i>	020-48
020.14.3.1	SXE-2 / MX-F	020-48
020.14.3.2	SXE-2 100	020-48
020.14.3.3	SXE-2 150	020-49
020.14.3.4	SXE-2 220	020-49
020.14.3.5	SXE-2 400	020-49
020.14.3.6	SXE-2 760	020-49

030 Maintenance 030-1

030.1	Maintenance and inspection schedule	030-11
030.2	Filling quantities and lubrication chart	030-16
030.2.1	Recommended lubricants <i>L580-1464;</i>	030-16
030.2.2	Recommended operating fluids <i>L580-1464;</i>	030-17
030.3	Lubricants and fuels	030-18
030.3.1	General information on lubricants and fuels	030-18

030.6.10.2	Gearbox: service calibration <i>L580-1464;</i>	030-255
030.6.10.3	Travel gearbox: Check power output <i>L580-1464;</i>	030-258
030.6.10.4	Transmission: Reversing test <i>L580-1464;</i>	030-261
030.6.10.5	Transmission control unit (TCU): Software update <i>L580-1464;</i>	030-263
030.6.11	Axles and drive shafts	030-266
030.6.11.1	Tyres: setting radius <i>L580-1464;</i>	030-266
030.6.12	Working attachment	030-267
030.6.12.1	Valve block for quick coupler (option): Pressure reducing valve <i>L580-1464;</i>	030-267
030.6.12.2	Parameters for lift arm geometry <i>L580-1464;</i>	030-268
030.6.12.3	Working attachment: automatic return of 3rd function <i>L580-1464;</i>	030-270
030.6.13	Operator's cab, heating and air conditioning	030-271
030.6.13.1	Checking the pressure and temperature conditions of the air conditioning unit <i>L580-1464;</i>	030-271
030.6.13.2	Calibrating the display (Display4) <i>L580-1464;</i>	030-272
030.6.13.3	Formatting the display and reinstalling the software (Display4) <i>L580-1464;</i>	030-273
030.6.14	Options	030-274
030.6.14.1	Checking the LiDAT connection status <i>L580-1464;</i>	030-274
030.6.14.2	LiDAT: activating data transmission manually <i>L580-1464;</i>	030-276
030.6.14.3	Skyview 360°: calibration <i>L580-1464;</i>	030-278
030.6.14.4	Personnel detection: transmitting configuration files <i>L580-1464;</i>	030-285
040	Drive group	040-1
040.1	Engine	040-3
040.1.2	Electrical components of diesel engine <i>L580-1464;</i>	040-7
040.1.3	Sensors on diesel engine <i>L580-1464;</i>	040-11

010 Introduction

Contents

010.1	Safety instructions	010-4
010.1.1	Information on these instructions	010-4
010.1.1.1	Representation of warning messages	010-4
010.1.1.2	Graphic symbols in these instructions	010-4
010.1.2	Intended use	010-5
010.1.2.1	Laws, rules, guidelines and safety regulations	010-5
010.1.2.2	Intended use	010-5
010.1.2.3	Foreseeable misuse	010-6
010.1.2.4	Operating conditions	010-6
010.1.2.5	Disposal	010-7
010.1.3	Description of staff	010-7
010.1.3.1	Personal protective equipment	010-7
010.1.3.2	Requirements for staff	010-8
010.1.3.3	Operating company	010-8
010.1.3.4	Operator	010-9
010.1.3.5	Maintenance staff	010-9
010.1.3.6	Refrigeration technician	010-10
010.1.3.7	Slinger	010-11
010.1.3.8	Spotter	010-12
010.1.4	Protective devices on the machine	010-12
010.1.4.1	Operator's cab	010-12
010.1.4.2	Roll over protective structure (ROPS)	010-13
010.1.4.3	Falling object protective structures (FOPS)	010-13
010.1.5	Emergency equipment on the machine	010-13
010.1.5.1	Emergency exit (standard)	010-13
010.1.5.2	Fire extinguisher (option)	010-14
010.1.6	Safe operation	010-14

LBH/11835201/20/21+20191218_101659/en

- Is able to estimate distance, height and gaps.
- The refrigeration technician has completed training that complies with the country-specific laws, standards and guidelines.
- The refrigeration technician has following skills:
 - Is able to assess work correctly.
 - Is able to recognise dangers.
 - Is able to take safety measures.
- Has knowledge and experience of the relevant field of activity.
- Knows the relevant national standards.
- Has the necessary authorisation for maintenance and repair of machine.
- Knows the machine and the hazards.
- Knows all procedures and precautions for maintenance.
- Has knowledge of handling special tools for maintenance and repair.
- Is not under any physical or mental impairment that limits one of the prescribed requirements.
- Is not under the influence of alcohol.
- Is not under the influence of drugs.

010.1.3.7 Slinger

Responsibility

Slinger is responsible for following:

- Wear personal protective equipment.
- Choose correct and undamaged slinging gear.
- Correctly attach slinging gear to load or lifting accessory.
- Correctly remove slinging gear from load or lifting accessory.
- Grant approval for movement or accompaniment.

Requirement

The slinger has following qualification and skills:

- Has completed the legally specified minimum age.
- Physically and mentally capable of slinging loads:
 - Satisfactory eyesight
 - Satisfactory hearing ability
 - Quick reactions
 - Is able to estimate distance, height and gaps.
- The slinger has following skills:
 - Is able to estimate mass distribution and load distribution.
 - Is able to operate radio units.
 - Is able to give clear instructions on radio units.
 - Is able to guide a load.
- Has the necessary authorisation for attaching loads.
- The slinger has the necessary education (theoretical and practical) for the following:
 - Selecting the suitable slinging gear
 - Attaching slinging gear
 - Securing to prevent unintended disengaging of slinging gear
 - Avoiding damage to slinging gear
 - Spotting
 - Applying all necessary signal signs
- Is not under any physical or mental impairment that limits one of the prescribed requirements.
- Is not under the influence of alcohol.
- Is not under the influence of drugs.

Environmental pollution

- When working in following areas, adhere to laws, regulations and rules applicable at place of use:
 - Areas at risk of water (for example bodies of water)
 - Sound-sensitive areas
 - Emission-sensitive areas

010.1.7 Safe maintenance

010.1.7.1 Spare parts

Danger to life

Incorrect spare parts

- Use original spare parts.
- Make sure that the spare parts meet the technical requirements specified by the manufacturer.
- After replacing parts, tighten loosened screw connections with prescribed tightening torque.
- Find prescribed tightening torque in supplied documentation.
- If the tightening torque is not prescribed by the supplied documentation: Find prescribed tightening torque in Liebherr factory standard.
- If the tightening torque is not prescribed by the Liebherr factory standard: Find tightening torque in valid DIN standard, EN standard or ISO standard.

010.1.7.2 Heavy parts

Danger to life

Incorrect handling

- Exclusively use machine for load-lifting with sufficient loading capacity.
- Exclusively use suitable and functioning lifting accessories with sufficient loading capacity.
- Make sure there are no persons underneath raised loads.
- Exclusively task qualified and experienced persons with the attaching of loads.
- Exclusively task qualified and experienced persons with the directing of operators.
- Make sure that the spotter can be seen by the operator.
- Make sure that spotter and operator are in voice contact if necessary.

Injury

Incorrect protective equipment

- Put on gloves when handling wire ropes.

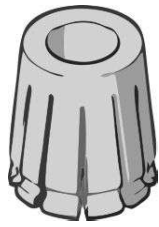
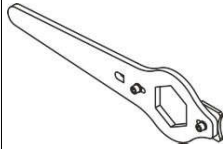
Designation	Item code	Remark	Fig.
Expansion sleeve 180 mm	9110413	For fitting seals	
Piston wrench 110 mm	9600928	Only up to serial no. 53475: for assembly of piston	

Tab. 9: Special tools for tilt cylinders with industrial lift arms

010.2.7 Special tools for steering wheel

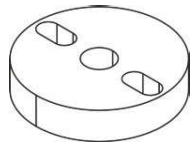
Designation	Item code	Remark	Fig.
Extractor for steering wheel	10430204	For steering wheel removal	

Tab. 10: Special tools for steering wheel

010.2.8 Special tools for steering cylinders

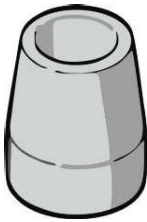
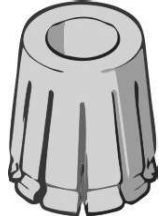
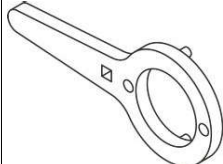
Designation	Item code	Remark	Fig.
Mounting sleeve 90 mm	9227161	For fitting the seals	
Expansion sleeve 90 mm	9227162	For fitting the seals	
Piston wrench 60/10 mm	9131362	For fitting the piston	

LBH/11835201/20/21+20191218_101659/en

Metric standard threads and fine threads				Metric standard threads and fine threads			
At least one element of the bolted joint (bolts, washers, nuts etc.) with the following surface: fZn = zinc flake coating (LH standard 10021432, LH standard 10215295 fZnnc-480h-L valid \geq M6)				All elements of the bolted joint (bolts, washers, nuts etc.) with the following surface: Black oxide or phosphated Galvanised (LH standard 10215295 Fe//ZnNi(12)5//Cn//T2)			
Minimum total coefficient of friction $\mu_G = 0.09$				Minimum total coefficient of friction $\mu_G = 0.11$			
Thread	Strength class	Assembly prestressing forces F_M in kN	Tightening torques M_A in Nm	Thread	Strength class	Assembly prestressing forces F_M in kN	Tightening torques M_A in Nm
M 7	8.8	15.3	13.9*	M 7	8.8	15.0	16.1
	10.9	22.5	20.4*		10.9	22.0	23.6
	12.9	26	23.9*		12.9	26	28
M 8	8.8	19.3	20.6*	M 8	8.8	18.9	23.8
	10.9	28	30*		10.9	28	35
	12.9	33	35*		12.9	32	41
M 8 x 1	8.8	21.0	21.7*	M 8 x 1	8.8	20.5	25
	10.9	31	32*		10.9	30	37
	12.9	36	37*		12.9	35	43
M 9 x 1	8.8	27	31*	M 9 x 1	8.8	27	36
	10.9	40	46*		10.9	39	53
	12.9	47	53*		12.9	46	62
M 10	8.8	31	40	M 10	8.8	30	47
	10.9	45	59		10.9	44	68
	12.9	53	69		12.9	52	80
M 10 x 1	8.8	35	44	M 10 x 1	8.8	34	51
	10.9	51	64		10.9	50	75
	12.9	60	75		12.9	59	88
M 10 x 1.25	8.8	33	42	M 10 x 1.25	8.8	32	49
	10.9	48	62		10.9	47	72
	12.9	56	72		12.9	55	84
M 12	8.8	45	69	M 12	8.8	44	80
	10.9	66	102		10.9	64	118
	12.9	77	119		12.9	75	140
M 12 x 1.25	8.8	50	74	M 12 x 1.25	8.8	49	86
	10.9	73	109		10.9	71	125
	12.9	85	125		12.9	84	150
M 12 x 1.5	8.8	47	72	M 12 x 1.5	8.8	46	83
	10.9	69	105		10.9	68	122
	12.9	81	123		12.9	79	145

LBH/11835201/20/21+20191218_101659/en

010.5 Preservation guidelines for the SCR system

010.5.1 Putting out of service for longer than 2 months

The SCR system can be put out of service for more than 2 months under the following conditions:

- To prevent urea crystals from accumulating, the SCR system must be checked for leaks and damage.
- Electric or hydraulic connections must not be disconnected.

010.5.2 Starting up after being out of service for longer than 2 months

Before starting up after being out of service for more than 2 months, the following tasks must be carried out:

- Check the SCR system for visible damage.
- Check the electrical and hydraulic lines of the SCR system for damage.
- Check the electrical and hydraulic connections of the SCR system for damage.
- Check the quality of the diesel exhaust fluid (item code for analysis kit: 11698484). If the quality of the diesel exhaust fluid no longer meets the specifications, it must be drained.
- Before operating the diesel exhaust fluid pump, the diesel exhaust fluid tank must be filled to the maximum.

Once the above tasks have been carried out, the function of the SCR system must be tested.

This test is done using the LIDIA engine diagnostic software. The test must be carried out with the engine running.

Test the following functions of the SCR system with the engine running:

- Test the air circuit.
- Test the diesel exhaust fluid circuit.
- Test the blowing out function.

Once these tests have been carried out and no faults have been found, the SCR system can be started up.

	Designation	Unit	Value	
C	Maximum bucket base height	mm	4145	4145
D	Maximum bucket pivot point height	mm	4490	4490
E	Maximum bucket top height	mm	6265	6330
F	Reach at maximum lifting height and 45° tilt-out angle	mm	1290	1230
G	Digging depth	mm	100	100
H	Height above operator's cab	mm	3590	3590
I	Height above exhaust	mm	3200	3200
J	Ground clearance	mm	465	465
K	Wheelbase	mm	3710	3710
L	Overall length	mm	9545	9650
	Turning radius over bucket outer edge	mm	7560	7590
	Breakout force (SAE)	kN	200	185
	Tipping load when straight	kg	20150	19700
	Tipping load when fully articulated (ISO 14397-1)	kg	17750	17300
	Operating weight	kg	28050	28200

Tab. 26: Complete machine with loading bucket (industrial lift arms)

- A) Industrial lift arms with parallel guidance including quick coupler
- B) Earth bucket with short, straight base for quick coupler
- C) Welded tooth holder with plug-in teeth
- D) In practice, the bucket capacity can be around 10% greater than as calculated using the ISO 7546 standard. The bucket filling level depends on the type of material.

020.1.3 Working attachment: light material bucket

Valid for: L580-1464;

Values stated refer to machine:

- In standard version
- With 26.5R25 L3 tyres (For more information see: [020.10.6 Tyres, page 020-40](#))
- Including all lubricants
- With a full fuel tank
- With ROPS/FOPS cab and operator
- On level and stable ground



Note

Tyres and working attachments affect operating weight and tipping load.

- ▶ Note information about tyres and working attachment.

020.3 Cooling system

020.3.1 Fan pump

Valid for: L580-1464;

Description	Unit	Value
Type		External gear pump
Displacement per turn	cm ³	14
Direction of rotation		Anticlockwise

020.3.2 Fan motor

Valid for: L580-1464;

Description	Unit	Value
Type		External gear motor
Displacement per turn	cm ³	19
Direction of rotation		Anticlockwise
Pressure relief	bar	220
Weight	kg	6.82

020.3.3 Hydraulic oil temperature sensor B8

Valid for: L580-1464;

Description	Unit	Value
Minimum temperature	°C	-30
Maximum temperature	°C	130
Resistance at 20 °C	Ω	1000
Connecting thread	mm	M14x1.5
Tightening torque	Nm	30

Description	Unit	Value
Connecting thread	mm	M12x1.5
Tightening torque	Nm	25

020.6.8 Joystick steering control valve block

Valid for: L580-1464/0-54742;

Description	Unit	Value
Type		P-05 P357
Pressure reducing valves for pilot control pressure	bar	25 ⁺⁵
Maximum flow rate through main control valve	l/min	150
Maximum flow rate through emergency control valve	l/min	40
Resistance of solenoid for safety circuit Y74	ohms	48.7
Power consumption of solenoid for safety circuit Y74	W	12
Control current for proportional control solenoids for steering Y70, Y71, Y72, Y73	mA	0 to 750
Resistance of proportional control solenoids for steering Y70, Y71, Y72, Y73	ohms	20.8
Output signal of position sensors	mA	4 to 20
Weight	kg	20.5

020.6.9 Joystick steering control valve block

Valid for: L580-1464/54743-;

Description	Unit	Value
Type		S-01 P357
Pressure reducing valves for pilot control pressure	bar	25 ⁺⁵
Maximum flow rate through main control valve	l/min	150
Maximum flow rate through emergency control valve	l/min	70
Resistance of solenoid for safety circuit Y74	ohms	48.7
Power consumption of solenoid for safety circuit Y74	W	12
Control current for proportional control solenoids for steering Y70, Y71, Y72, Y73	mA	0 to 750
Resistance of proportional control solenoids for steering Y70, Y71, Y72, Y73	ohms	20.8

LBH/11835201/20/21+20191218_101659/en

020.10 Axles and drive shafts

020.10.1 Front axle

Valid for: L580-1464;

Description	Unit	Value
Type		MT-L3115II
Self-locking differential level	%	45
Flange size	mm	2314
Overall transmission		24.71
Number of brake plates per wheel hub		5
Brake plate lining		Sintered
Weight	kg	1740

020.10.2 Rear axle

Valid for: L580-1464;

Description	Unit	Value
Type		MT-L3115II
Self-locking differential level	%	45
Flange size	mm	2314
Overall transmission		24.71
Number of brake plates per wheel hub		5
Brake plate lining		Sintered
Weight	kg	1740

020.10.3 Drive shaft between diesel engine and transmission

Valid for: L580-1464;

Description	Unit	Value
Minimum length	mm	1485
Maximum length	mm	1595
Weight	kg	30.8

020.14.3.3 SXE-2 150

Description	Unit	Value
Flow per outlet	mm ³	150
Flow per element	mm ³	300
Piston diameter	mm	5

020.14.3.4 SXE-2 220

Description	Unit	Value
Flow per outlet	mm ³	220
Flow per element	mm ³	440
Piston diameter	mm	6

020.14.3.5 SXE-2 400

Description	Unit	Value
Flow per outlet	mm ³	400
Flow per element	mm ³	800
Piston diameter	mm	8

020.14.3.6 SXE-2 760

Description	Unit	Value
Flow per outlet	mm ³	760
Flow per element	mm ³	1520
Piston diameter	mm	11

030.6.9	Electrical system	030-236
030.6.9.1	Central control unit (Master4) Creating a Servicefile <i>L580-1464;</i>	030-236
030.6.9.2	Central control unit (Master4): software update <i>L580-1464;</i>	030-239
030.6.9.3	Setting the IP addresses of the central control unit (Master4) <i>L580-1464;</i>	030-242
030.6.9.4	Resetting the central control unit (Master4) <i>L580-1464;</i>	030-245
030.6.9.5	Testing the CAN line <i>L580-1464;</i>	030-246
030.6.9.6	Addressing CAN module and checking system information <i>L580-1464;</i>	030-249
030.6.10	Gearbox	030-253
030.6.10.1	Gearbox: basic calibration <i>L580-1464;</i>	030-253
030.6.10.2	Gearbox: service calibration <i>L580-1464;</i>	030-255
030.6.10.3	Travel gearbox: Check power output <i>L580-1464;</i>	030-258
030.6.10.4	Transmission: Reversing test <i>L580-1464;</i>	030-261
030.6.10.5	Transmission control unit (TCU): Software update <i>L580-1464;</i>	030-263
030.6.11	Axles and drive shafts	030-266
030.6.11.1	Tyres: setting radius <i>L580-1464;</i>	030-266
030.6.12	Working attachment	030-267
030.6.12.1	Valve block for quick coupler (option): Pressure reducing valve <i>L580-1464;</i>	030-267
030.6.12.2	Parameters for lift arm geometry <i>L580-1464;</i>	030-268
030.6.12.3	Working attachment: automatic return of 3rd function <i>L580-1464;</i>	030-270
030.6.13	Operator's cab, heating and air conditioning	030-271
030.6.13.1	Checking the pressure and temperature conditions of the air conditioning unit <i>L580-1464;</i>	030-271
030.6.13.2	Calibrating the display (Display4) <i>L580-1464;</i>	030-272

030.3.3 Converting hydraulic system from mineral oils to biodegradable hydraulic fluids

For operation of Liebherr earth moving machines with biodegradable hydraulic fluids, we recommend **Liebherr Hydraulic Plus**.

In the case of a machine equipped with biodegradable hydraulic fluid at the factory, a corresponding information label is attached.

Procedure for later conversion

NOTICE

Non-approved oil!
Damage to the hydraulic system.

- ▶ Only use oil that meets the Liebherr specifications.
 - ▶ Do not mix different oils.
-
- ▶ In case of subsequent conversion of machine to a biodegradable hydraulic fluid, contact Liebherr customer service!
 - ▶ Request **instructions** and **conversion guidelines** from Liebherr and observe them!

030.3.4 Diesel fuels

Valid for: L580-1464;

030.3.4.1 Minimum quality requirement

Approved diesel fuels	As per DIN EN 590, ASTM D 975 1-D / 2-D
Maximum sulphur content	15 ppm
Minimum cetane number	45
Lubricity at 60 °C (HFRR)	Maximum 460 µm

Tab. 38: Minimum quality requirement

Do not mix diesel fuel with additives.

030.3.4.2 Operating temperatures of diesel fuels

Approved diesel fuels according to DIN EN 590	Cloud point	Ambient temperature
Class standard	-7 °C	to -10 °C
Arctic class 0	-10 °C	to -13 °C
Arctic class 1	-16 °C	to -20 °C

Tab. 39: Operating temperatures of diesel fuels

For applications under -10 °C use preheating or arctic diesel. For more information about arctic diesel grades, see table on operating temperatures and DIN EN 590.

- Changing filters

030.4.2.1 Maintenance positions

Valid for: L580-1464;

The maintenance position depends on the maintenance task to be performed.

The two basic maintenance positions 1 and 2 are described below.

They enable you to access the individual maintenance points.

Maintenance position 1

To move the machine into maintenance position 1, carry out the following steps.

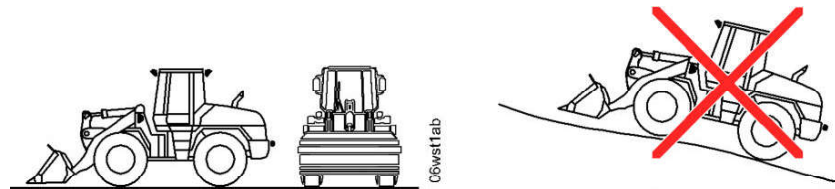

Fig. 92: Maintenance position 1

- ▶ Park the machine on level ground.
- ▶ Lower the lift arms.
- ▶ Lay the bucket flat on the ground.
- ▶ Engage the parking brake.
- ▶ Turn off the engine.
- ▶ Take out the ignition key.
- ▶ Turn off the battery main switch.

Maintenance position 2

To move the machine into maintenance position 2, carry out the following steps.



Fig. 93: Maintenance position 2

- ▶ Park the machine on level ground.
- ▶ Engage the articulation lock.
- ▶ Lower the lift arms.
- ▶ Tilt the bucket out and set it down on the ground on its teeth or cutting edge.
- ▶ Engage the parking brake.
- ▶ Turn off the engine.

Regular cleaning prevents dirt and foreign particles from getting into the machine.

Clean the machine immediately after the following work:

- Working in salty environments (for example contact with road salt, or by the sea)
- Working with alkaline or acidic substances
- Working with corrosive materials (such as lime compounds or cement)

NOTICE

Always carry out cleaning correctly

Risk of damage to the machine.

- ▶ Only clean electrical systems, cables and wiring harnesses with low-pressure equipment.
 - ▶ Only clean soundproofing material with low-pressure equipment.
 - ▶ When new (or after respraying), do not clean the machine with a high-pressure cleaner for two months.
 - ▶ Observe the operating manual of the high-pressure cleaner.
-

NOTICE

Incorrect cleaning!

Damage to cameras and sensors.

- ▶ Only clean components with low pressure or damp, soft cloth.
-



CAUTION

High-pressure jet!

Risk of injury.

- ▶ Wear protective clothing and safety glasses.
-

Cleaning the outside of the machine

Before cleaning

Make sure the following preconditions are met:

- Machine is in maintenance position 2.

Before washing with water or with a high-pressure cleaner, carry out the following tasks in order to prevent water from getting inside.

- ▶ Lubricate all bearings and pin connections.
- ▶ Clean oil, fuel and maintenance products from all connections and bolts.

If components behind openings have to be prevented from water getting in:

- ▶ Cover or mask the openings.

Components particularly at risk are:

- Electric motors
- Control units
- Electrical components
- Relay boards and fuse boards
- Plug connections
- Sensors
- Air filter
- Exhaust system

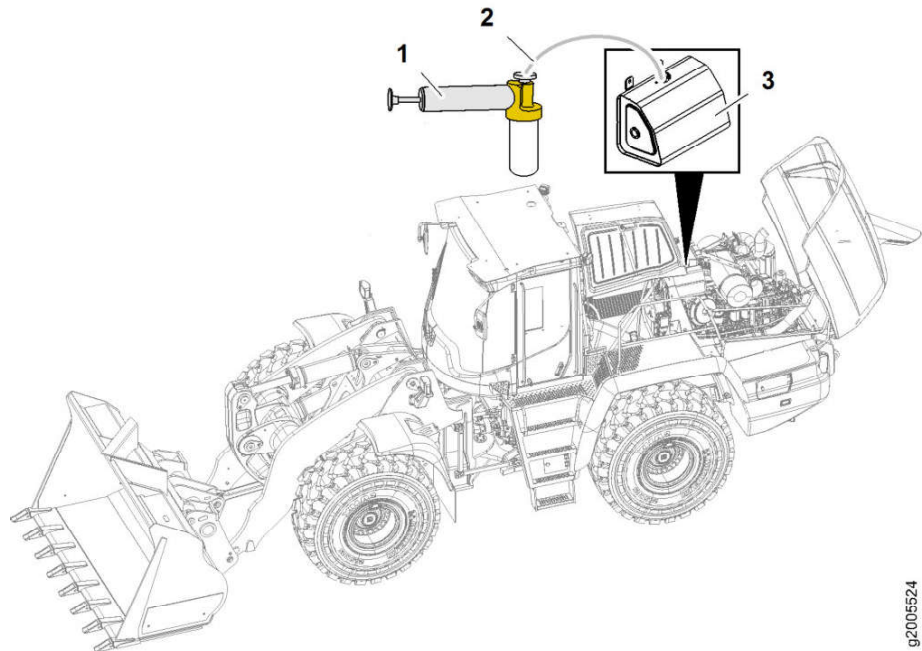

g2006524

Fig. 109: Sampling point for coolant

- 1 Hand pump
2 Sampling hose
3 Coolant equalising reservoir

- ▶ Start diesel engine.
- ▶ Turn heating to maximum temperature and wait for three minutes.
 - ▷ The coolant is circulated.
- ▶ Put the machine in maintenance position 1.



CAUTION

Hot, pressurised fluid!
Beware of burns.

- ▶ The coolant temperature must not exceed 45 °C.
- ▶ Wear protective clothing and safety glasses.
- ▶ Carefully open the cap.

- ▶ Carefully open the cap on the coolant equalising reservoir 3.
- ▶ Insert the sampling hose 2 and take a coolant sample.
- ▶ Close the cap.

Transmission

The oil sample is taken via the oil filling tube on the transmission using a hand pump.

030.4.4.5 Changing diesel engine belt drive

Valid for: L580-1464;

Make sure that following requirements are fulfilled:

- Machine is in maintenance position 1.
- Service access is open.

Make sure that following tools are ready:

- 1/2" ratchet
- Loctite 243 thread lock (included in service package)

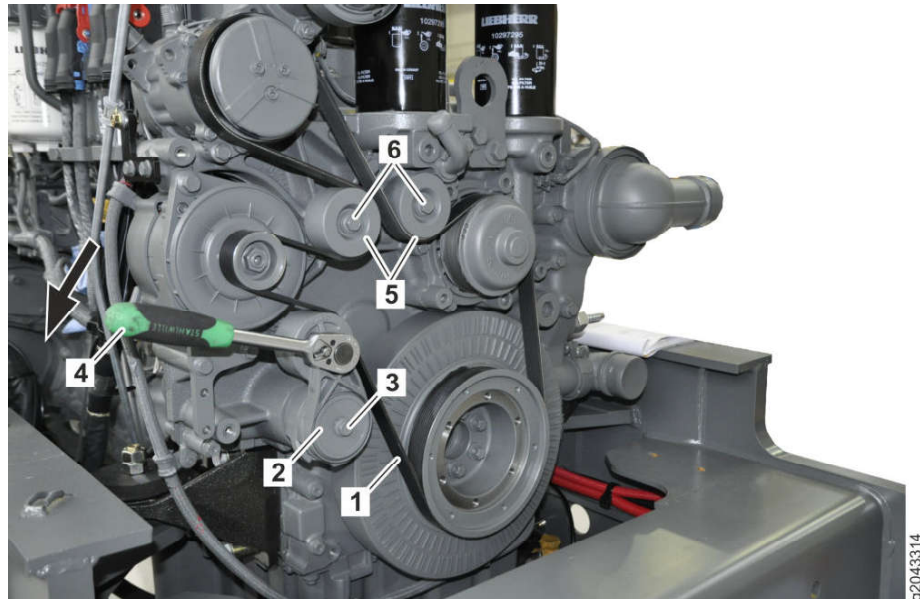

Fig. 119: Changing V-ribbed belt

- | | | | |
|---|--------------------------------------|---|--|
| 1 | V-ribbed-belt | 4 | Ratchet |
| 2 | Tensioning device | 5 | Deflection rollers |
| 3 | Hex head screw for tensioning device | 6 | Hex head screws for deflection rollers |

- ▶ Pull back tensioning device **2** with the ratchet **4** against the spring force as far as it will go.
- ▶ Take off V-ribbed belt **1**.
- ▶ Loosen hex head screw for tensioning device **3**.
- ▶ Wet new hex head screw **3** with thread lock.
- ▶ Secure new tensioning device **2** with hex head screw **3**.
- ▶ Loosen hex head screws for deflection rollers **6**.
- ▶ Wet new hex head screws **6** with thread lock.
- ▶ Secure new deflection rollers **5** with hex head screws **6**.
- ▶ Put on new V-ribbed-belt **1** with tensioning device **2** moved back.
- ▶ Move tensioning device **2** forward.
 - ▷ V-ribbed-belt **1** is tensioned.
- ▶ Remove ratchet **4**.
- ▶ Start diesel engine.

**CAUTION**

Pressurised fluids that are irritants to the skin!
Risk of injury.

- ▶ Wear safety gloves and goggles.
-
- ▶ Put hand pump in the *PUMP* position **1**.
 - ▶ Operate hand pump until you feel strong resistance.
 - ▶ Put hand pump in the *RUN* position **2**.
 - ▶ Start diesel engine.

Troubleshooting

If machine will not start after approx. 20 sec.:

- ▶ Wait one minute and repeat starting process.

Once you have repeated this three times:

- ▶ Repeat bleeding process.

**Note**

- ▶ Low-pressure circuit of the diesel engine is bled via permanently installed restrictor ports. No other measures are necessary.

030.4.4.13 Changing fuel fine filter element

Valid for: L580-1464;

Make sure that following requirements are met:

- Machine is in maintenance position 1.
- Service access is open.
- You have a suitable receptacle ready.
- Diesel engine has cooled down.

Make sure that following tool is ready.

- Receptacle

**WARNING**

Highly flammable consumables!
Beware of burns.

- ▶ Avoid naked lights and fire.

**CAUTION**

Pressurised fluids that are irritants to the skin!
Risk of injury.

- ▶ Wear safety gloves and goggles.

- The engine has cooled down.

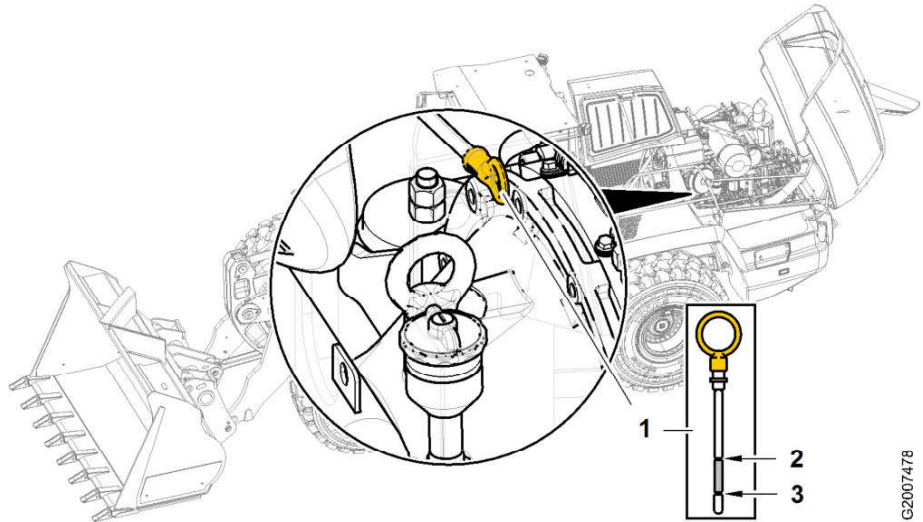

Fig. 139: Checking the oil level

- 1 Dipstick
- 2 Maximum oil level
- 3 Minimum oil level

- ▶ Pull out the dipstick 1, wipe it clean, and re-insert it.
- ▶ Pull out the dipstick 1 once again and read off the oil level.
 - ▷ The oil level on the dipstick 1 must be between the maximum 2 and minimum 3.

If the oil level is below the minimum 3:

- ▶ Top up the oil. (For more information see: [Topping up the oil, page 030-79](#))

Troubleshooting

If the oil is above the maximum level 2:

- ▶ Contact Liebherr customer service.
-

Topping up the oil

Make sure that the following requirements are fulfilled:

- The machine is in maintenance position 1.
- The service access is open.
- The machine is level.
- The engine has cooled down.

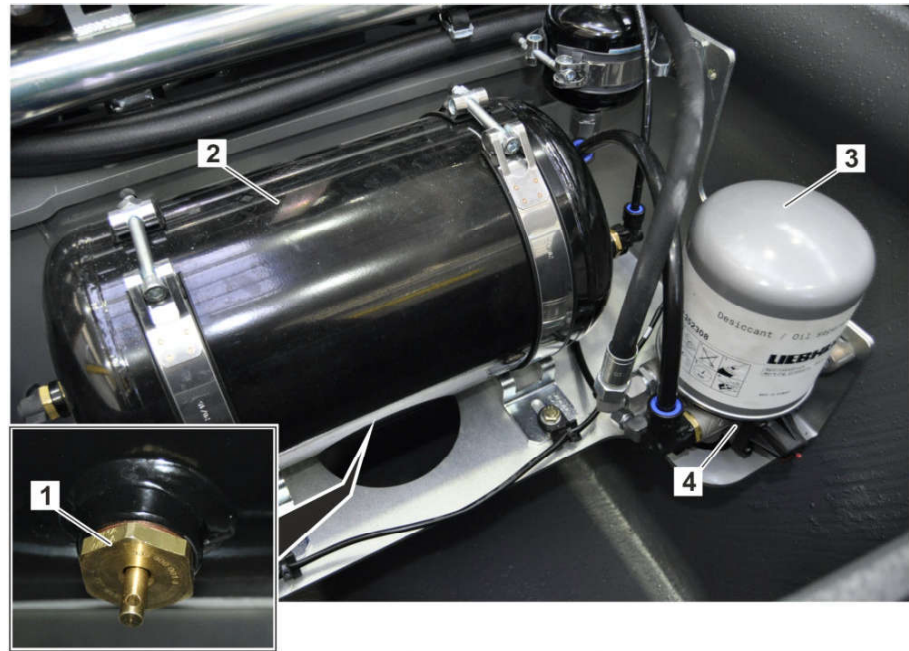

Fig. 148: Changing the compressed air dryer

- | | | | |
|---|-----------------|---|----------------|
| 1 | Drain valve | 3 | Air dryer |
| 2 | Pressure vessel | 4 | Filter bracket |

The air dryer is installed in the right ballast weight.

- ▶ Remove the right ballast cover.
- ▶ Let the air out of the compressed air system through the drain valve 1 until there is no more pressure in the system.
 - ▷ The compressed air system is depressurised.
 - ▷ The condensation water has been drained.
- ▶ Unscrew the air dryer 3.
- ▶ Check the filter bracket 4 for damage and dirt.
- ▶ Slightly grease threaded stud on the filter bracket 4 with lubrication grease.
- ▶ Lightly coat sealing faces of new air dryer with grease.
- ▶ Screw on the new air dryer until the sealing ring touches the filter bracket.
- ▶ Tighten the air dryer half a turn by hand.
- ▶ Start diesel engine.



WARNING

Hot components!
Risk of injury.

- ▶ Do not touch components of the exhaust system and the engine.
- ▶ Check the filter bracket and the air dryer for leaks.
- ▶ Turn off diesel engine.
- ▶ Install right ballast cover again.

- ▶ Unscrew the cap of the drain valve **3** (see: fig. 154, page 030-97) .
- ▶ Screw the drain hose onto the drain valve **3** (see: fig. 154, page 030-97) .
 - ▷ Coolant flows out.
- ▶ Drain off as much coolant as the amount of pure corrosion inhibitor or pure water to be topped up.
- ▶ Unscrew the drain hose from the drain valve **3** (see: fig. 154, page 030-97) .
- ▶ Screw the cap onto the drain valve **3** (see: fig. 154, page 030-97) .

NOTICE

Non-approved coolant!
Damage to the engine and cooling system.

- ▶ Only use coolant that meets the Liebherr specifications.
- ▶ Do not mix coolants with and without silicates.

- ▶ Top up the equalising reservoir **2** (see: fig. 154, page 030-97) with corrosion inhibitor or pure water.
- ▶ Close the cap **1** (see: fig. 154, page 030-97) of the equalising reservoir **2** (see: fig. 154, page 030-97) .
- ▶ Start diesel engine.
- ▶ Set the heater to the maximum temperature and blower speed.
- ▶ Run machine for five minutes at upper diesel engine speed.
 - ▷ The coolant is circulated.
- ▶ Turn off diesel engine.
- ▶ Wait until the diesel engine has cooled down.

**CAUTION**

Hot, pressurised liquid!
Beware of burns.

- ▶ Let the engine cool down.

- ▶ Carefully open the cap **1** (see: fig. 154, page 030-97) of the equalising reservoir **2** (see: fig. 154, page 030-97) .
- ▶ Check the concentration of corrosion inhibitor and correct it if necessary.
- ▶ Close the cap **1** (see: fig. 154, page 030-97) of the equalising reservoir **2** (see: fig. 154, page 030-97) .

030.4.5.3 Cleaning the cooling system

Valid for: L580-1464;

Clean the coolers whenever necessary in order to ensure proper cooling. In dusty environments, check the coolers every day and clean them if necessary.

Dirty cooler units cause overheating. This results in an audible and visual warning with simultaneous power reduction of the travel drive.

Dust and other dirt can be removed from the cooling fins using a high-pressure cleaner or compressed air. Compressed air is preferable.

Make sure that the following requirements are fulfilled:

- The machine is in maintenance position 1.

- ▶ Activate the working hydraulics lockout.

**DANGER**

Unintended movement of the machine!
Fatal injury.

- ▶ Make sure no-one can enter the operator's cab.

**CAUTION**

Hot fluids!
Burns.

- ▶ Avoid skin contact with fluids.

- ▶ Connect a test line 1 to the test connection PA on the control valve block.
- ▶ Drain at least 0.2 l of hydraulic oil into the receptacle.
 - ▷ The test line 1 is flushed.
- ▶ Fill the sample container 2.
- ▶ Disconnect the test line 1 from the test connection PA.
- ▶ Turn off the diesel engine.

030.4.6.6 Changing the oil in the hydraulic tank

Valid for: L580-1464;

Make sure that the following requirements are fulfilled:

- The oil is at operating temperature.
- The machine is in maintenance position 1.
- The service hatches are open.

Make sure that the following tools are ready:

- Drain hose
- Receptacle (150 l)
- Torque wrench

Make sure that the following consumables are ready:

- Hydraulic oil according to the table of lubricants. (For more information see: [030.2.1 Recommended lubricants, page 030-16](#))

**Note**

Information on the oil specification:

- ▶ See the section on lubricants and fuels. (For more information see: [030.3.11 Hydraulic oil, page 030-25](#))

NOTICE

Ensure that hydraulic oils are correctly mixed.
Damage to the hydraulic system.

- ▶ Do not mix hydraulic oils.

Checking the wear on the brake linings

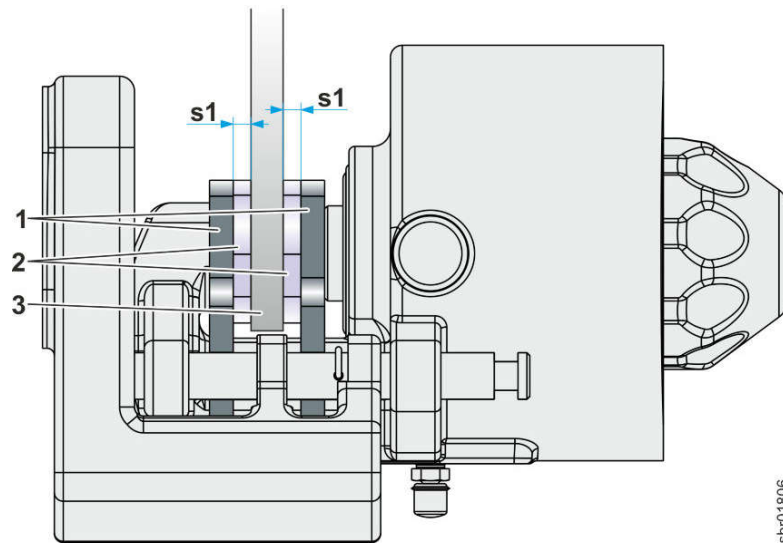

Fig. 179: Checking the wear on the brake linings

- | | | | |
|---|--------------|----|-------------------------------|
| 1 | Brake shoe | 3 | Brake disc |
| 2 | Brake lining | s1 | Thickness of the brake lining |

► Check that both brake linings are the required thickness **s1**.

Description	Unit	Value
Minimum thickness s1 of each brake lining	mm	2.0

If the value is correct:

► Check the gap. (For more information see: [Check the gap, page 030-120](#))

If the value is not correct:

► Replace both brake shoes. (For more information see: [Replace the brake shoes, page 030-121](#))

Make sure that the following requirements are fulfilled:

- The machine is in maintenance position 1.

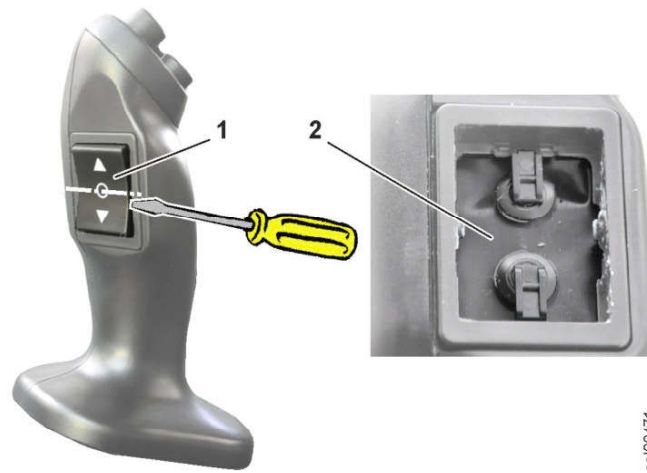

Fig. 187: Changing the travel direction rocker switch

1 Rocker

2 Seal

NOTICE

Thin seal!
Damage to the seal.

- ▶ Do not put in the screwdriver more than 5 mm.

-
- ▶ Insert the tip of a small screwdriver between the rocker **1** and the travel direction switch below the central axis.
 - ▶ Prise out the rocker.
 - ▶ Check the seal **2** for damage.

If the seal is damaged:

- ▶ Replace the travel direction switch.
- ▶ Fit a new rocker on the travel direction switch.

Changing the button cover (optional)

Make sure that the following requirements are fulfilled:

- The machine is in maintenance position 1.

Lubricating the lift arms

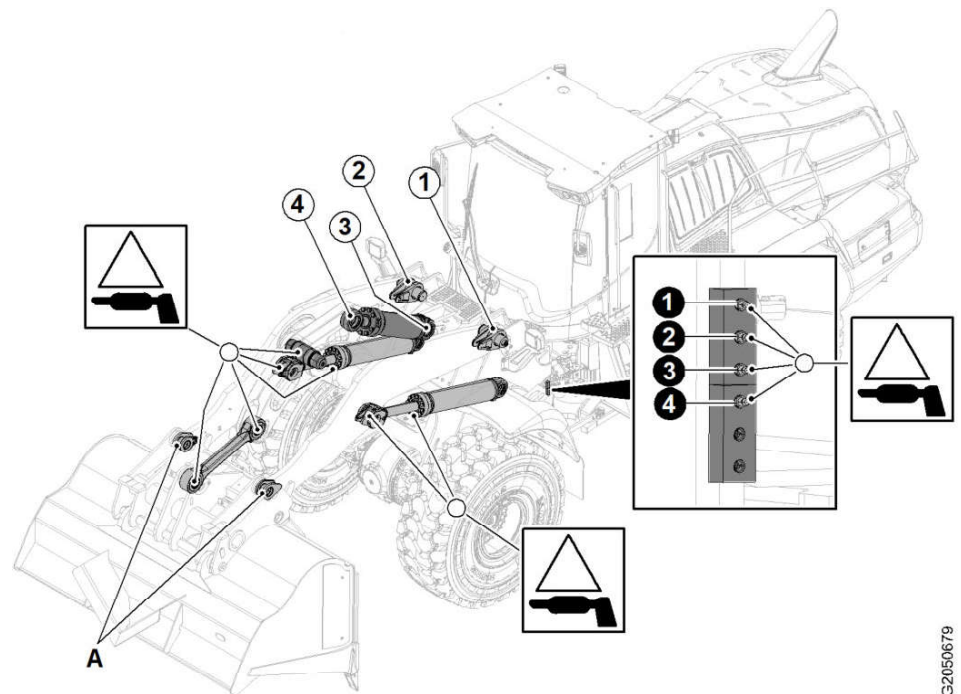

Fig. 209: Lubricating the lift arms

A Lower bucket bearing

- ▶ Take the cap off the grease fitting.
- ▶ Grease the lift arm bearings at the lubrication points.
- ▶ The lower bucket bearings **A** should be lubricated daily in accordance with requirements.
- ▶ Put the cap on the grease fitting.

G2050679

Cleaning the recirculated air filter

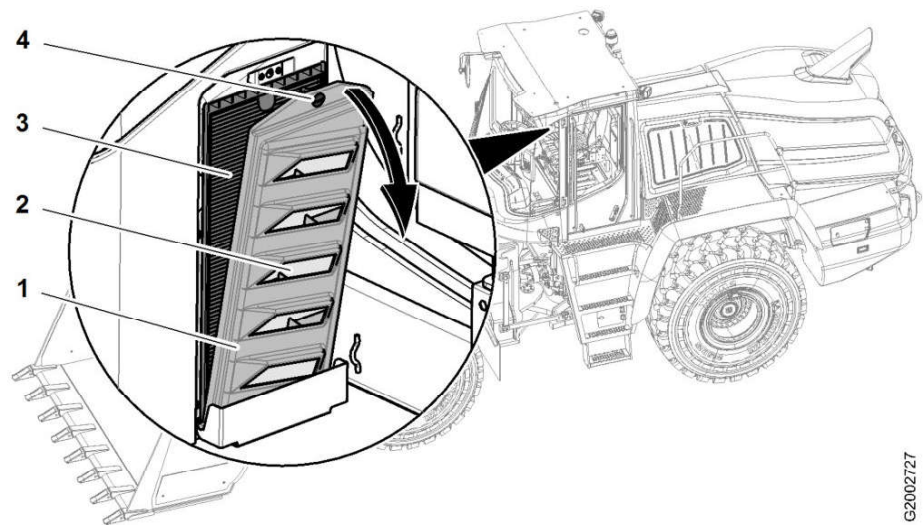

G2002727

Fig. 219: Cleaning the recirculated air filter

- | | | | |
|---|------------------|---|-------------------------|
| 1 | Filter cartridge | 3 | Recirculated air filter |
| 2 | Pre-filter | 4 | Knurled screw |

- ▶ Unscrew the knurled screw **4**.
 - ▷ The filter cartridge **1** is unlocked.
- ▶ Move the filter cartridge **1** forward and take it out.
- ▶ Take the pre-filter **2** out of the filter cartridge **1** and clean it (by blowing it out or washing it).
- ▶ Take out the recirculated air filter **3** and clean it (blow it out).
- ▶ Put in the clean recirculated air filter **3**.
- ▶ Put the pre-filter **2** into the filter cartridge **1** and fit them.
- ▶ Screw in the knurled screw **4**.
 - ▷ The filter cartridge **1** is locked.

030.4.14.2 Changing the fresh and recirculated air filters in the cab

Valid for: L580-1464;

Make sure that the following requirements are fulfilled:

- The machine is in maintenance position 1.
- The right cab access is extended.
- Suitable protective equipment is used.

030.5 Testing and adjustment checklist

Valid for: L580-1464;



Note

Carry out jobs in adjustment checklist after completing maintenance tasks!

Machine: L580-1464	Serial no.: []	Operating hours: []	Date: []	Tested by: []
Customer: []				
Location: []				

Tab. 79: Customer data and machine data

1. Preparations									
Test / adjustment	1000 h	2000 h	Unit	Required value	Measured	Adjusted	Adjusting point	Test point	Figure
Complete machine									
Preparing for adjustment procedures									
Preparing for adjustment procedures	<input type="radio"/>	<input type="radio"/>				[]			
Deactivate critical functions	<input type="radio"/>	<input type="radio"/>				[]			
Hydraulic oil: operating temperature									
Bringing hydraulic oil up to operating temperature	<input type="radio"/>	<input type="radio"/>	°C	50 ^{±10}		[]			
Gear oil operating temperature									
Bringing gear oil up to operating temperature	<input type="checkbox"/>	<input type="radio"/>	°C	55 ⁺⁵		[]			

Tab. 80: Preparations

2. Calibrations									
Test / adjustment	1000 h	2000 h	Unit	Required value	Measured	Adjusted	Adjusting point	Test point	Figure
Transmission									
Gearbox: service calibration									
Automatic hydrostat calibration	<input type="checkbox"/>	<input type="radio"/>				[]			
Automatic clutch calibration	<input type="checkbox"/>	<input type="radio"/>				[]			

LBH/11835201/20/21+20191218_101659/en

In the service management, service codes are saved in the central control unit under the following conditions:

- Service confirmed by the driver within the specified period
- Service message hidden by the driver within the specified period
- Service confirmed by the technician within the specified period
- Service confirmed by the technician outside the specified period
- Service not confirmed

Confirming service

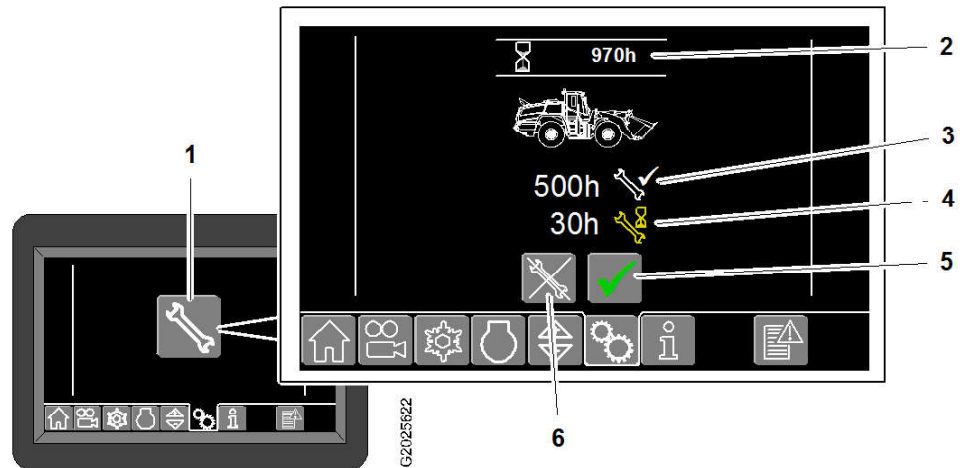

Fig. 231: Service management

- | | | | |
|---|---|---|--|
| 1 | Service management button | 4 | Operating hours until next service |
| 2 | Machine operating hours | 5 | Machine operator service confirmation button |
| 3 | Operating hours when service last confirmed | 6 | Hide service message button |

- ▶ Connect the Sculi diagnostic software to the machine.
- ▶ In the variables editor, select the **Service management** folder.
- ▶ Set the **MXServiceACK** variable to **1**.
 - ▷ After a short time, the **MXServiceACK** variable returns to **0**.
 - ▷ The Operating hours when service last confirmed **3** variable changes to the value of the current operating hours.
 - ▷ The Operating hours until next service **4** value shows how long it is until the next service.
 - ▷ The service is confirmed.
 - ▷ The service code is stored in the central control unit.

030.6.3 Drive group

030.6.3.1 Pedals: calibration

Valid for: L580-1464;

Make sure that the following requirements are fulfilled:

- The machine is parked on level ground.

Make sure that the following tools are ready:

- Laptop with Sculi diagnostic software

**Note**

Large bucket can scrape ground!
Calibration is not possible.

- ▶ If necessary, remove bucket before calibration or position machine so that bucket does not scrape ground.

**Note**

Hitting limit position too fast!
Incorrect calibration.

- ▶ Reduce tilt speed before reaching limit position.
- ▶ Tilt out bucket to limit position within 20 seconds and then tilt it all way in.
- ▶ Wait until variable **MXSIWEStartBuckAngleAdj** returns to **0**.
 - ▷ Calibration is completed.
- ▶ Check that calibration was successful.

Checking whether calibration is successful

- ▶ Tilt bucket out slightly and then tilt it all way in.

**Note**

Variable **PRSIWE_Length_BuckCylPercent** can only display values between 0% and 100%. This means variable must not reach its required value until moment limit position is reached!

- ▶ When limit stop is reached, check whether variable **PRSIWE_Length_BuckCylPercent** reaches value 100^{-0.5%}.
- ▶ Tilt bucket all way out.

**Note**

Variable **PRSIWE_Length_BuckCylPercent** can only display values between 0% and 100%. This means variable must not reach its required value until moment limit position is reached!

- ▶ When limit stop is reached, check whether variable **PRSIWE_Length_BuckCylPercent** reaches value 0^{+0.5%}.

If a required value is not reached:

- ▶ Repeat calibration.

If required values are reached:

- ▶ Carry out final test.

Final test

- ▶ Tilt bucket in until value of variable **PRSIWE_Length_BuckCylPercent** is between 45% and 55%.
- ▶ Move lift arms all way up and down.
- ▶ Check how much value of variable **PRSIWE_Length_BuckCylPercent** changes.

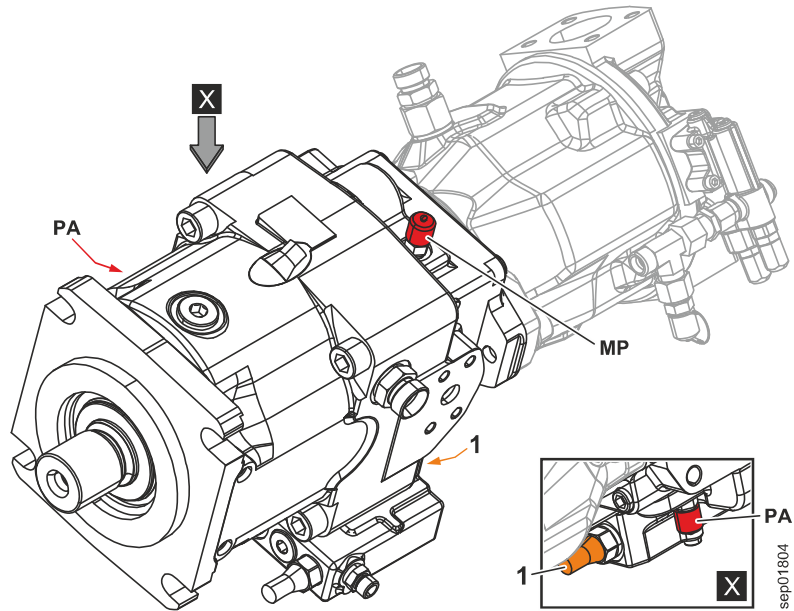

Fig. 242: Working pump: power regulator

1 Power regulator **MP** Working pump return pressure test connection

PA Working pump high pressure test connection

- ▶ Connect a pressure gauge (600 bar) to the high pressure test connection **PA** on the working pump.
- ▶ Connect a pressure gauge (600 bar) to the return pressure test connection **MP** on the working pump.
- ▶ Start the diesel engine.
- ▶ Raise the lift arms slightly and tilt the bucket all the way out.
- ▶ Fully activate the lifting function at low idling speed.
- ▶ Check the high pressure **PA** level at which the return pressure **MP** starts increasing (working pump starts regulating).

Description	Unit	Value
High pressure PA	bar	180 ±10

If the required value is not reached:

- ▶ Set the bucket down on the ground on its teeth or cutting edge.
- ▶ Turn off the diesel engine and take out the ignition key.
- ▶ Adjust the adjusting screw of the power regulator **1**.



Note

To adjust the power regulator:

- ▶ Turn the adjusting screw clockwise to increase the high pressure.
- ▶ Turn the adjusting screw anticlockwise to reduce the high pressure.

- ▶ Repeat the check and adjustment until the required value is reached.

LBH/11835201/20/21+20191218_101659/en

Preparations

- ▶ Connect a pressure gauge (600 bar) to high pressure test connection **PA** on control valve block.
- ▶ Turn adjusting screw on LS-pressure cut-off valve **1** by exactly one turn clockwise.
 - ▷ Opening pressure of LS-pressure cut-off valve is above opening pressure of primary pressure relief valve.
- ▶ Make sure that critical functions are deactivated. (For more information see: [Deactivate critical functions, page 030-176](#))

Checking and adjusting

- ▶ Starting diesel engine
- ▶ Raise lift arms as far as they will go.
- ▶ Fully activate lifting function at low idling speed.
- ▶ While doing so, check whether high pressure **PA** corresponds to specified value.

Description	Unit	Value
High pressure PA	bar	390 ^{±5}

If required value is not reached:

- ▶ Set bucket down on ground on its teeth or cutting edge.
- ▶ Turn off diesel engine and take out ignition key.
- ▶ Turn adjusting screw of primary pressure relief valve **2**.



Note

To adjust primary pressure relief valve:

- ▶ Turn adjusting screw clockwise to increase high pressure.
- ▶ Turn adjusting screw anticlockwise to reduce high pressure.

- ▶ Repeat check and adjustment until required value is reached.

If required value is reached:

- ▶ Set bucket down on ground on its teeth or cutting edge.
- ▶ Turn off diesel engine and take out ignition key.
- ▶ Turn adjusting screw on LS-pressure cut-off valve **1** by exactly one turn anticlockwise.
- ▶ Check and adjust LS-pressure cut-off valve. (For more information see: [Industrial lift arms control valve block \(option\): LS-pressure cut-off, page 030-209](#))

030.6.5.13 Industrial lift arms control valve block (option): LS-pressure cut-off

Valid for: L580-1464;

Make sure that following requirements are met:

- Hydraulic oil is at operating temperature.
- Machine is in maintenance position for adjustment procedures.
- Service access is open.



Fig. 258: Cracks on the clamping sleeve or blisters on the outer jacket

- ▶ Take the machine out of operation and secure it against restarting.
- ▶ Replace the damaged hydraulic line immediately.

030.6.7 Steering system

030.6.7.1 Joystick for joystick steering (option): calibration

Valid for: L580-1464/55878-;



Note

Only applicable for joystick with position tracking!

Make sure that following requirements are met:

- Machine is safely parked.

Make sure that following tools are ready:

- Laptop with Sculi diagnostic software
- ▶ Start diesel engine.
- ▶ Connect Sculi diagnostic software to machine.
- ▶ In variables editor, select **Joystick steering** folder.
- ▶ Make sure that parking brake is activated.
- ▶ Fold up left armrest.
 - ▷ Joystick steering is deactivated.
- ▶ Set variable **MXJSForceFbBetaAdjStart** to **1**.
 - ▷ Calibration takes place automatically.
 - ▷ Joystick moves independently.
- ▶ Wait until variable **MXJSForceFbBetaAdjStart** returns to **0**.
 - ▷ Calibration is completed.

030.6.7.2 Angle sensor for articulation angle (option): calibration

Valid for: L580-1464;

Make sure that following requirements are met:

- Hydraulic oil is at operating temperature.
- The machine is parked on level ground.
- There is enough space available to steer machine.

**Note**

To adjust flow regulator:

- ▶ Turning adjusting screw clockwise reduces differential pressure.
- ▶ Turning adjusting screw anticlockwise increases differential pressure.

- ▶ Repeat check and adjustment until required value is reached.

If required value is reached:

- ▶ Turn off diesel engine and take out ignition key.
- ▶ Disconnect differential pressure measuring device or pressure gauge from high pressure test connection **PL**.
- ▶ Disconnect differential pressure measuring or pressure gauge from load sensing signal test connection **LSL**.

030.6.7.8 Steering damper hydro accumulator nitrogen filling

Valid for: L580-1464;

Make sure that the following requirements are fulfilled:

- The hydraulic oil is at operating temperature.
- The machine is in the maintenance position for adjustment procedures.

Make sure that the following tools are ready:

- Testing and filling device for hydro accumulator

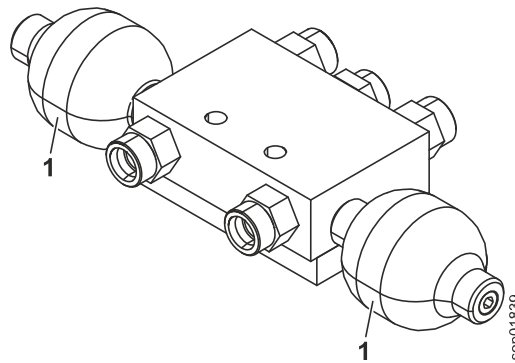

Fig. 263: Steering damper hydro accumulator nitrogen filling

1 Steering damper hydro accumulator

- ▶ Engage the articulation lock.
- ▶ With the diesel engine shut off, turn the steering wheel by half a turn to the left and by half a turn to the right.
 - ▷ The steering cylinders are depressurised.
- ▶ Check and top up the nitrogen filling of the steering damper hydro accumulators **1**. (For more information see: [Hydro accumulator: checking and topping up nitrogen filling, page 030-213](#))



- ▶ Start the “SCOTTI” function.

**Note**

After a updating or installing the Sculi diagnostic software, it can take several minutes to make a connection using the “SCOTTI” function.

- ▶ Do not interrupt the loading process.



- ▶ Select the “machine data” function.

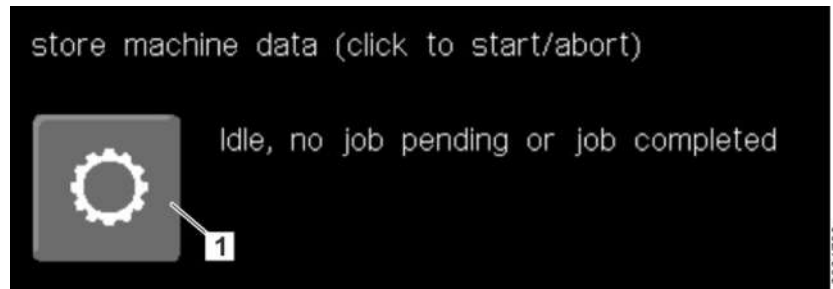

Fig. 277: Starting the download

1 “store machine data” function

- ▶ Start the “store machine data” function 1.
 - ▷ Start the download.
 - ▷ The diagnostic software creates a folder on the memory card in slot CF2. The folder is named with the serial number of the machine. The service file is saved in this folder.
 - ▷ A bar shows the progress of the download.
 - ▷ When the download is complete, the following text appears: Idle, no job pending or job completed
- ▶ Switch off the ignition.
- ▶ Remove the memory card from slot CF2.
- ▶ Read the service file on the memory card using a memory card reader.

030.6.9.2 Central control unit (Master4): software update

Valid for: L580-1464;

The software of central control unit also includes the software for the individual components of electronic system.

When the software of central control unit is updated, the software of following components is updated:

- Central control unit (Master4)
- Input modules
- Output modules
- Display

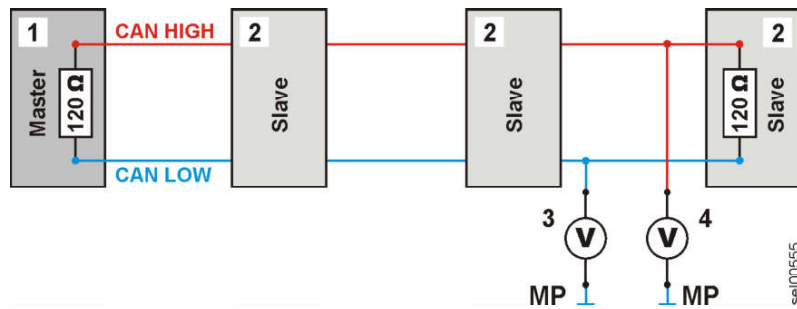

Fig. 286: Measuring the voltage on the CAN line

- 1 Central control unit (Master4)
- 2 CAN node
- 3 Multimeter between CAN LOW and earth
- 4 Multimeter between CAN HIGH and earth
- MP Earth

- ▶ Switch on the battery main switch.
- ▶ Turn the ignition key to position I.
- ▶ Set the multimeter to voltage metering.
- ▶ Connect the multimeter to earth.
- ▶ Connect the multimeter to CAN HIGH or CAN LOW.
- ▶ Measure the voltage.

Measurement	Diagnosis	Malfunction
The voltage on CAN HIGH is 2.6 V to 3.5 V	The central control unit is communicating with the CAN line.	No
The voltage on CAN LOW is 1.5 V to 2.4 V	The central control unit is communicating with the CAN line.	No
The voltage on CAN HIGH and CAN LOW is the same.	The central control unit is functioning but is not communicating with the CAN line.	Yes
There is no voltage	The line is broken.	Yes
The voltage on CAN HIGH or CAN LOW corresponds approximately with that of the machine voltage (12 V or 24 V)	The CAN line is in contact with the machine voltage.	Yes
The voltage on CAN HIGH or CAN LOW is 0.	The CAN line is connected to earth.	Yes

Tab. 96: Diagnosis

030.6.9.6 Addressing CAN module and checking system information

Valid for: L580-1464;

Addressing CAN modules

The CAN modules are addressed using Sculi diagnostic software.

LBH/11835201/20/21+20191218_101659/en

- ▶ Valid from software version 020: set variable **CXDCHPCThrtActivate** to **0**.
 - ▷ Electronic control function is deactivated.
 - ▷ Speed reduction of diesel engine is more clearly visible.
- ▶ Select the following variables and send them to the oscilloscope:
 - ▷ **REngActTorque**: diesel engine: current torque load
 - ▷ **PRTCURAvailTorquePATOT**: XPower gearbox: available torque
 - ▷ **PRTCURCurrTorquePCTOT**: XPower gearbox: current torque
 - ▷ **PRMaAnEngActSpeed**: diesel engine: speed
 - ▷ **PRMaAnEngActTorque**: diesel engine: current torque
 - ▷ **MRMachineSpeed**: machine: speed
 - ▷ **PRTD_PCTOT_PATOT_ReIP**: XPower gearbox: ratio of PCTOT to PATOT in percent
 - ▷ **PREngSpeedReqActDiff**: diesel engine: current droop (difference between specified and actual engine speed)

Checking the travel gearbox



- ▶ Start oscilloscope.
 - ▷ The readings of the selected variables are recorded.

- ▶ Fully depress the accelerator pedal until the maximum travel speed (approx. 10 km/h) is reached.

Once the maximum speed has been reached:

- ▶ keep accelerator pedal fully depressed.
- ▶ At the same time, press the inching brake pedal until the machine slows to a speed of 6 km/h bis 8 km/h.
 - ▷ The travel gearbox works against the braking force of the machine. That places a load on the travel gearbox.



Note

In order to get a meaningful measurement, the inching brake pedal has to be pressed **evenly**.

Press the inching brake pedal evenly for 8 to 10 seconds.

- ▶ Maintain that situation for 8 to 10 seconds.
- ▶ Release accelerator pedal.
- ▶ Release the inching brake pedal.
- ▶ Stop the oscilloscope.

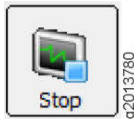

- ▶ Save the oscilloscope recording.

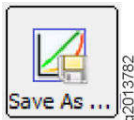

- ▶ Set the variable **CXInchPdIDisableInch** to **0**.
 - ▷ The inching function is now enabled.
- ▶ Set variable **CXDCHPCThrtActivate** to **1**.

2 Bucket pivot point with direct attachment X Lift arm length

- ▶ To find the lift arm length X, measure the distance between the pivot point of the lift arms 1 and the bucket pivot point 2 or 3.
- ▶ Enter the parameter set for the appropriate lift arm version in the variable **CDWESpecType**.

Lift arms	Design	Lift arm length X	Parameter set
Z-bar kinematics	up to serial no. 53475: standard – item code of tilt cylinder 94077900	3050 mm	3005
Z-bar kinematics	up to serial no. 53475: long lift arm (option) – item code of tilt cylinder 94077900	3250 mm	3011
Z-bar kinematics	from serial no. 53476: standard – item code of tilt cylinder 11833995	3050 mm	3014
Z-bar kinematics	from serial no. 53476: long lift arm (option) – item code of tilt cylinder 11833995	3250 mm	3015
Industrial lift arms	Standard	2900 mm	4001

Tab. 105: Lift arm versions

Setting the bucket length



Note

From software version 011, set the bucket length using the display!

- ▶ For more information, see the section in the operating manual on calibrating working attachments.

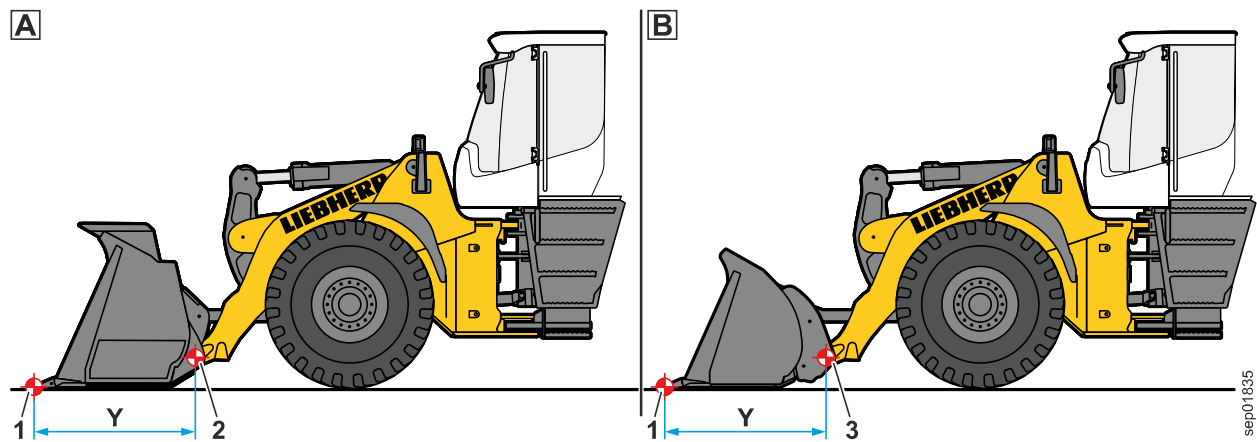

Fig. 302: Bucket length with direct attachment / bucket length with quick coupler

- | | | | |
|---|---|---|---------------------------------------|
| 1 | Bucket tip | 3 | Bucket pivot point with quick coupler |
| 2 | Bucket pivot point with direct attachment | Y | Bucket length |

LBH11835201/20/21+20191218_101659/en

sep01835

Position	Machine type	Distance
X2	L526 to L546	10 m
	L550, L556	11 m
	L566, L576, L580	12 m
	L586	13 m

Tab. 106: Aligning machine

- ▶ Prepare design data. (For more information see: [Preparing design data, page 030-279](#))

Preparing design data

Design data are available via Liebherr service documentation. File path: General - Skyview 360° - Design data

Design data include machine-specific and general design data.

Save design data before calibration in a folder with designation "Designs".



Fig. 316: Preparing design data

- 1 Machine-specific design data 2 Folder "Templates"

Folder "Designs" with general design data is available in folder "Templates" 2 in Liebherr service documentation. Folder "Designs" contains three PNG files.

- ▶ Save folder "Designs" uncompressed on laptop.

Folder 1 contains machine-specific design data.

- ▶ Save file with machine-specific design data from folder 1 to folder "Designs".
 - ▷ Design data are prepared.
- ▶ Perform calibration. (For more information see: [Calibration, page 030-279](#))

Calibration

Make sure that following requirements are met:

- Machine is aligned.
- Design data are prepared.

Make sure that following tools are ready:

- Laptop with diagnostic software ASL Configuration Tool and exe file Power-broker. (For more information see: [Diagnostic software, page 190-26](#))

040 Drive group

Contents

040.1	Engine	040-3
040.1.2	Electrical components of diesel engine <i>L580-1464;</i>	040-7
040.1.3	Sensors on diesel engine <i>L580-1464;</i>	040-11
040.1.4	Ambient temperature sensor <i>L580-1464;</i>	040-22
040.1.5	Fuel system	040-24
040.1.5.2	Fuel level sensor <i>L580-1464;</i>	040-28
040.1.5.3	Separ fuel pre-filter <i>L580-1464;</i>	040-30
040.1.6	Air filter system	040-30
040.1.6.1	Air filter <i>L580-1464;</i>	040-31
040.1.6.2	Air mass sensor <i>L580-1464;</i>	040-32
040.1.7	Exhaust system	040-33
040.1.7.1	Overview of exhaust gas treatment system <i>L580-1464;</i>	040-33
040.1.7.2	Metering unit <i>L580-1464;</i>	040-38
040.1.7.3	Sampling module <i>L580-1464;</i>	040-41
040.1.7.4	Exhaust treatment sensors <i>L580-1464;</i>	040-42
040.1.7.5	Exhaust gas treatment with diesel particulate filter (option) <i>L580-1464;</i>	040-44
040.1.8	Compressed air system	040-47
040.1.8.1	Overview of the compressed air system <i>L580-1464;</i>	040-48
040.1.8.2	Compressor <i>L580-1464;</i>	040-50

installed in the plug **X724** on the diesel engine. Terminating resistor **R123** is installed in the rear section bear the ballast weight in the wiring harness.

Components of the CAN system are powered via fuses from the fuse board A4a.

CAN line 3 is used for diagnosis via the diesel engine diagnostic plug **X60a**. The diesel engine can only be diagnosed using the LiDIA software.

040.1.3 Sensors on diesel engine

Valid for: L580-1464;

1.1 Charge air pressure sensor B703

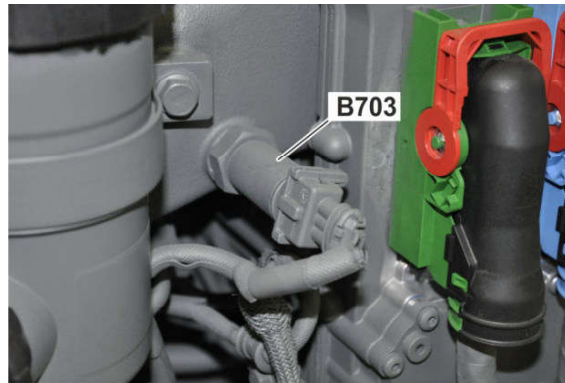

Fig. 341: Charge air pressure sensor

Charge air pressure sensor **B703** is installed in air intake pipe.

Charge air pressure is sent to engine control unit in form of a voltage signal.

if sensor fails, a substitute value of 5 bar is displayed. If sensor fails, engine control unit uses a computational model to continue running diesel engine.

Pin	Function
Pin 1	Ground
Pin 2	Output signal (0.5 to 4.5 V)
Pin 3	Power supply (5 V)

Tab. 112: Plug assignment

Charge air pressure	Output voltage
0.5 bar/a	0.5 V
1.5 bar/a	1.5 V
2.5 bar/a	2.5 V
3.5 bar/a	3.5 V
4.5 bar/a	4.5 V

Tab. 113: Output voltage

Pin	Function
3	Power supply (5 V)

Tab. 137: Plug assignment

Rail pressure	Output voltage
0.0 bar/g	0.5 V
200 bar/g	0.78 V
800 bar/g	1.62 V
1200 bar/g	2.18 V
1600 bar/g	2.74 V
1800 bar/g	3.02 V
2400 bar/g	3.86 V
2850 bar/g	4.5 V

Tab. 138: Output voltage

1.7.1.1 Measured values for diagnostics

Supply line diagnostics			
Check	Preconditions	Measurement	Required value
Sensor power supply	Ignition ON	Measure voltage between pins 2 and 3 on line.	$5^{±0.2}$ V
	Diesel engine OFF		
	Plug connection disconnected		
Lines shorted to earth	Ignition OFF	Measure resistance from pin 1 and pin 3 to earth.	More than 50 kΩ
	Plug connection disconnected		

Tab. 139: Supply line diagnostics

Sensor diagnostics			
Check	Preconditions	Measurement	Required value
Output signal voltage at lower idling speed	Diesel engine ON	Measure voltage between pins 2 and 3.	$1.7^{±0.2}$ V

Tab. 140: Sensor diagnostics

040.1.6.1 Air filter

Valid for: L580-1464;

1 Layout

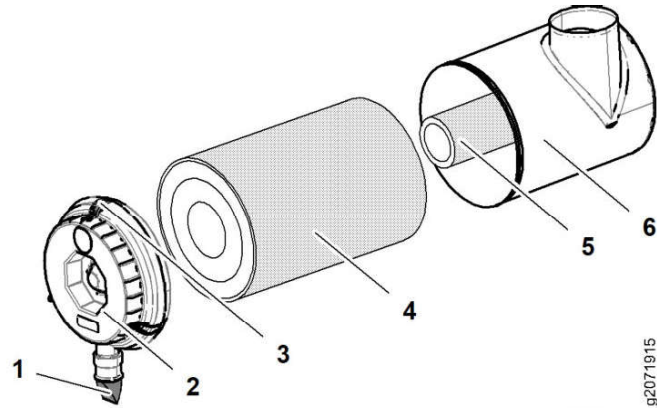

Fig. 357: Removing main element

- | | | | |
|---|----------------------|---|----------------|
| 1 | Dust discharge valve | 4 | Main element |
| 2 | Service cover | 5 | Safety element |
| 3 | Fixing clips | 6 | Filter housing |

2 Function

The main element **4** and the safety element **5** must be regularly replaced (see the maintenance and inspection schedule).

The safety element **5** is used as a back-up if the main element **4** is damaged.

The safety element **5** must be replaced after the main element is replaced three times, or as necessary.

The dust discharge valve **1** is used for automatically emptying the dust from the service cover **2**.

The tangential arrangement of the intake port sets the intake air into rotation, where centrifugal force throws the larger dust particles against the housing wall and the flow of intake air deposits them in the service cap **2**.

At idling speed, the collected dust particles in the service cover **2** are blown outside via the dust discharge valve **1** by the pulsations of the intake air.

The service cover **2** must be fitted so that the dust discharge valve **1** points downwards.

When the diesel engine is running (lower idle speed), you should clearly feel air pulsating at the dust discharge valve **1**.

040.1.7.3 Sampling module

Valid for: L580-1464;

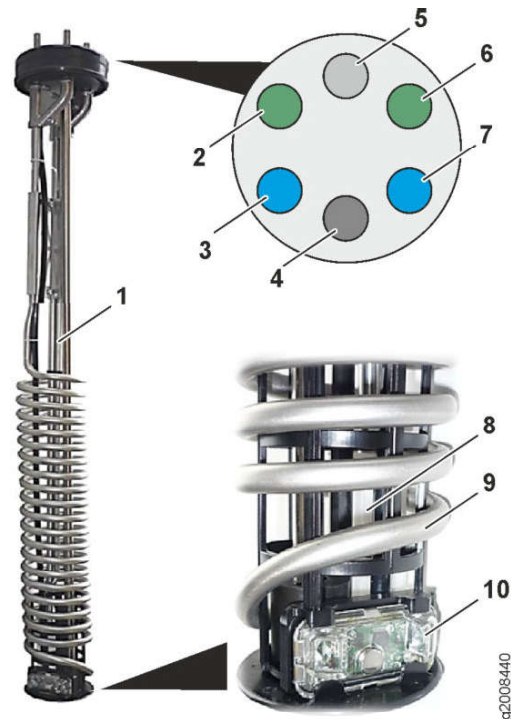

Fig. 369: Sampling module

1	Sampling module B774	6	Coolant to the diesel exhaust fluid tank
2	Coolant from the diesel exhaust fluid tank	7	Diesel exhaust fluid from the diesel exhaust fluid tank
3	Diesel exhaust fluid to the diesel exhaust fluid tank	8	Diesel exhaust fluid level sensor
4	Bleeder	9	Heating line
5	Electrical connection for sampling module B774	10	Diesel engine fluid quality sensor

The sampling module 1 for diesel engine fluid is integrated in the diesel exhaust fluid tank.

2.1 Function

Diesel exhaust fluid is taken from the tank via the sampling module 1.

The sampling module is heated with coolant from the engine. This means that diesel exhaust fluid can be sampled from the tank even at very low temperatures.

The sampling module is connected via CAN bus to the engine control unit.

The sampling module carries out the following measurements:

- Diesel exhaust fluid temperature (via an NTC resistor, measuring range: -40 °C to 125 °C)
- Diesel exhaust fluid level in the tank (measured using a reed contact)
- Diesel exhaust fluid quality (optical sensor, measuring range: 5% to 62.5%)

040.1.8.3 Air dryer

Valid for: L580-1464;

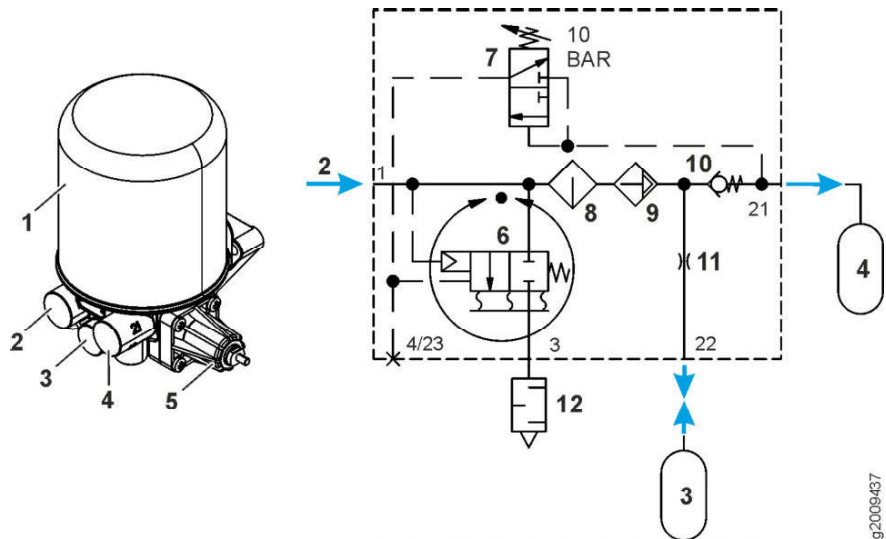

Fig. 381: Air dryer

- | | | | |
|---|-------------------------------------|----|---------------------|
| 1 | Filter cartridge | 7 | Pressure controller |
| 2 | Compressed air from the compressor | 8 | Fine filter |
| 3 | Regeneration accumulator | 9 | Granulate filter |
| 4 | Compressed air accumulator | 10 | Check valve |
| 5 | Pressure controller adjusting screw | 11 | Restrictor port |
| 6 | Drain valve | 12 | Silencer |

The air dryer is installed in the right ballast weight.

2.1 Function

The outside air drawn in by the compressor always contains a certain amount of moisture. This moisture can damage the compressed air system. Therefore, an air dryer is fitted behind the compressor. The air dryer reduces the humidity in the compressed air system.

Compressed air flows from the compressor 2 to the air dryer. The compressed air flows through the fine filter 8 and the granulate filter 9. The granulate in the filter removes moisture from the compressed air.

The dried air flows through the check valve 10 to the compressed air accumulator 4. At the same time, compressed air flows through restrictor port 11 to the regeneration accumulator 3.

The pressure controller 7 is set to 10 bar. If the pressure behind the check valve rises above 10 bar, the pressure controller cuts in. This actuates the drain valve 6.

When the drain valve 6 is actuated, compressed air from the compressor escapes through the silencer 12 to the outside. This lowers the pressure at the check valve 10. The check valve closes.

The drop in pressure in front of the check valve causes dry air from the regeneration accumulator 3 to flow through the restrictor port 11 via the filters 9 and 8 through the drain valve 6 and the silencer 12 to the outside.

2	Return flow from control valve block	7	Brake pump	12	Fan motor
3	Return filter	8	Oil supply for compact brake valve	13	Collector pipe
4	Breather filter	9	Working pump suction port	14	Return flow from servostat
5	Sight glass for hydraulic oil level	10	Working pump suction port drain valve	15	Hydraulic oil cooler

Name	Test point
PK	Cooling system high pressure

Tab. 143: Test points

BMK	Function	BMK	Function
B8	Hydraulic oil temperature sensor	Y13	Fan speed proportional solenoid

Tab. 144: Equipment codes

If temperature exceeds any of following specified values, current to proportional valve drops:

Specified values			
Specified value for temperature		Current to proportional solenoid (variable)	System pressure (variable)
Hydraulic oil	73 °C	850 mA to 320 mA	10 bar to 170 ⁺¹⁰ bar
Coolant	92 °C		
Charge air	50 °C		
Gear oil	73 °C		

Tab. 156: Specified values

Fan speed can be affected by external factors (altitude, dirt contamination etc.).

System pressure is dependent on current to proportional solenoid and speed of diesel engine.

2.3 Control characteristics when limits are exceeded

If any of four temperature readings exceeds a predefined limit, current applied to fan speed proportional solenoid is reduced to minimum current (standard setting: 320 mA).

Thresholds			
Temperature limits		Current to proportional solenoid	System pressure (at engine speed of 1750 min ⁻¹)
Hydraulic oil	88 °C	Minimum current (standard setting: 320 mA)	170 ⁺¹⁰ bar
Coolant	99 °C		
Charge air	80 °C		
Gear oil	88 °C		

Tab. 157: Thresholds

If a limit is exceeded, it has following effects:

- Current applied to proportional solenoid is reduced to minimum level.
- A warning sound goes off.
- A service code is displayed.
- In respect of coolant and charge air, power output of diesel engine is also reduced.
- In respect of transmission, emergency mode is activated.

2.4 Sensor failure

If temperature sensor for hydraulic oil B8 or temperature sensor for gear oil B86 fails, proportional solenoid for fan speed is powered with minimum current (default value: 320 mA).

Minimum current can also be adjusted by means of variable **CRFCFanCurrMin** in Sculi diagnostic software.

CLICK HERE TO **DOWNLOAD** THE COMPLETE MANUAL

- Thank you very much for reading the preview of the manual.
- You can download the complete manual from: www.heydownloads.com by clicking the link below



- Please note: If there is no response to **CLICKING** the link, please download this PDF first and then click on it.

CLICK HERE TO **DOWNLOAD** THE COMPLETE MANUAL

4	Return flow from hydraulic oil cooler	12	Pilot control hydro accumulator	20	Anti-drift valve
5	Sight glass for hydraulic oil level	13	Pilot control valve block	21	Right lift cylinder
6	Emergency steering pump suction port	14	Compact brake valve return flow	22	Tilt cylinder
7	Fan pump and brake pump suction port	15	Stabilization module		
8	Hydraulic tank drain valve	16	Left lift cylinder		

Name	Test point	Name	Test point	Name	Test point
LSA	Load sensing signal for working pump	MT	Servo pressure for tilt-out function	PA ^{A)}	Working pump high pressure
MP	Working pump return pressure	MV	Servo pressure		

Tab. 165: Test points

A) Test point on control valve block

BMK	Function	BMK	Function
B90	Pressure sensor for weighing device (piston side) (from serial number 54428)	Y14	Solenoid for servo pressure
B91	Pressure sensor for weighing device (ring side) (from serial number 54428)	Y20	Solenoid for ride control

Tab. 166: Equipment codes

BMK	Function	BMK	Function	BMK	Function
B8	Hydraulic oil temperature sensor	Y31a	Proportional solenoid for tilting out	Y33b	Proportional solenoid for 3rd function B3 (option)
B90	Pressure sensor for weighing device (piston side) (from serial number 54428)	Y31b	Proportional solenoid for tilting in	Y53	Solenoid for opening quick coupler (option)
B91	Pressure sensor for weighing device (ring side) (from serial number 54428)	Y32a	Proportional solenoid for lowering	Y53a	Quick coupler load sensing signal solenoid (option)
Y14	Solenoid for servo pressure	Y32b	Proportional solenoid for lifting		
Y20	Solenoid for ride control	Y33a	Proportional solenoid for 3rd function A3 (option)		

Tab. 174: Equipment codes

Working hydraulics is an open circuit. This means that after leaving consumer, oil flows to hydraulic tank rather than directly back to working pump.

Working pump **20** draws up oil from hydraulic tank **1** and pumps it to control valve block **45**. Control valve block **45** directs oil via spools to consumers.

Spool valves are electro-hydraulically actuated. To do this, oil is diverted from service brake hydro accumulators **39**. Pilot control pressure reducing valve **37** reduces pressure of this oil to servo pressure.

When working attachment is actuated, proportional solenoid valves for individual functions are energised. Proportional solenoid valves reduce servo pressure once more, depending on current, and direct servo oil to spool valves. Servo oil pushes spool valves against force of return springs. Oil flows from working pump **20** to consumers via openings that spools have accordingly released.

Pressure balances generate a load sensing signal which regulates working pump **20**.

Tilt function has an anti-drift valve **85**. Anti-drift valve separates tilt cylinder ring side from control valve block **45** when tilt function is not actuated. This prevents bucket from being tilted out accidentally due to leakage in spools **48**.

Ride control function absorbs vibrations that occur when driving with a loaded working attachment. Stabilization module **110** connects lift cylinder ring side to hydraulic tank **1** and lift cylinder piston side to ride control hydro accumulators.

6	Preload valve for 2nd tank duct	21	Return flow of stroke limit damping pressure relief valves	36	Connection to piston side of tilt cylinder
7	Spool lift limitation for tilting in	22	Pressure balance for 4th function	37	Connection to ring side of lift cylinder (left lift cylinder)
8	Spool lift limitation for lifting	23	Secondary pressure relief valve for 4th function B4	38	Connection to ring side of right lift cylinder and stabilization module
9	LS-pressure cut-off	24	Control valve block section for 4th function (option)	39	Connection to piston side of right lift cylinder and stabilization module
10	Flow control valve with strainer	25	Secondary pressure relief valve for 3rd function B3	40	Connection to piston side of lift cylinder (left lift cylinder)
11	Replenishing valve for tilting out	26	Pressure balance for 3rd function	41	Connection of 3rd function A3 (option)
12	Feeder valve for lowering	27	Control valve block section for 3rd function (option)	42	Connection of 3rd function B3 (option)
13	Spool lift limitation for 3rd function B3	28	Secondary pressure relief valve for lifting	43	Connection of 4th function A4 (option)
14	Secondary pressure relief valve for 3rd function A3	29	Secondary pressure relief valve for tilting in	44	Connection of 4th function B4 (option)
15	Spool lift limitation for 4th function B4	30	Anti-drift valve	45	Load sensing signal for working pump

Name	Test point	Name	Test point
LSA	Load sensing signal for working pump	PA	Working pump high pressure
MT	Servo pressure for tilt-out function		

Tab. 179: Test points

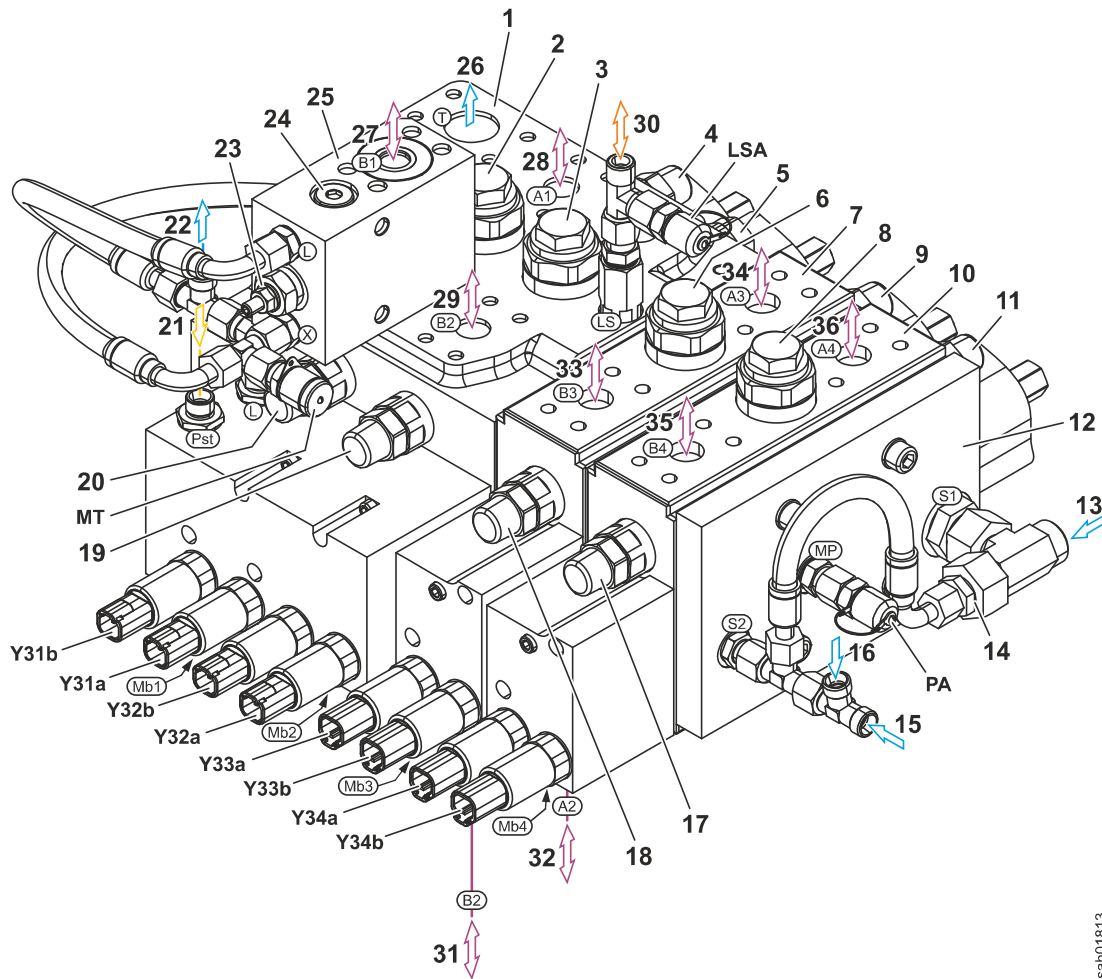

Fig. 420: Control valve block for industrial lift arms (from front right)

- | | | | | | |
|---|---|----|---|----|---|
| 1 | Control block | 13 | Return flow from stabilization module | 25 | Anti-drift valve |
| 2 | Tilt cylinder pressure balance | 14 | Orifice 1.0 mm | 26 | Return flow from return filter |
| 3 | Lift cylinder pressure balance | 15 | Return flow from compact brake valve (control valve block housing preheating) | 27 | Connection to ring side of tilt cylinder |
| 4 | Secondary pressure relief valve for tilting out | 16 | Return flow of stroke limit damping pressure relief valves | 28 | Connection to piston side of tilt cylinder |
| 5 | Dummy piston | 17 | Secondary pressure relief valve for 4th function B4 | 29 | Connection to piston side of right lift cylinder and stabilization module |
| 6 | Pressure balance for 3rd function | 18 | Secondary pressure relief valve for 3rd function B3 | 30 | Load sensing signal for working pump |
| 7 | Control valve block section for 3rd function (option) | 19 | Secondary pressure relief valve for lifting | 31 | Connection to piston side of lift cylinder (left lift cylinder) |
| 8 | Pressure balance for 4th function | 20 | Secondary pressure relief valve for tilting in | 32 | Connection to ring side of right lift cylinder and stabilization module |
| 9 | Secondary pressure relief valve for 3rd function A3 | 21 | Control oil from pilot control valve block | 33 | Connection of 3rd function A3 (option) |

See next page for continuation of the image legend

LBH11835201/20/21+20191218_101659/en

060.7.2 Stabilisation module

Valid for: L580-1464;

1 Layout

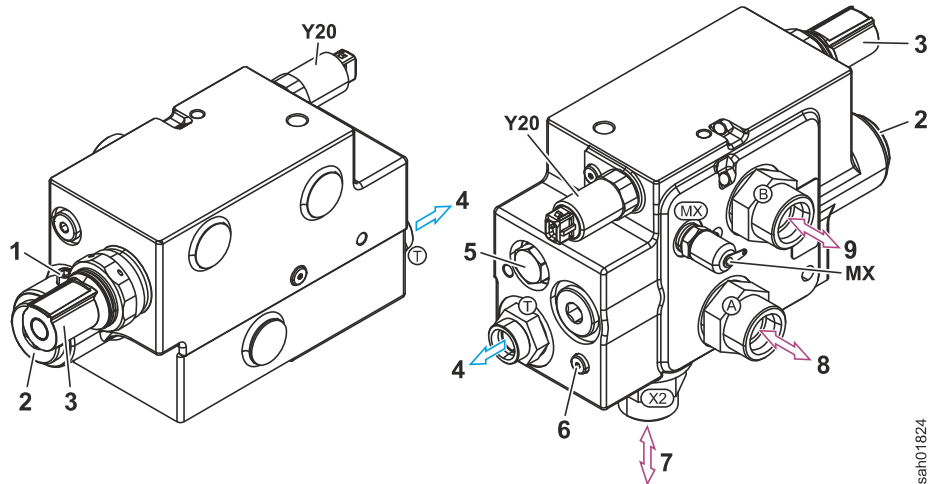

Fig. 426: Stabilisation module (from front left and from rear right)

- | | |
|--|---|
| <ul style="list-style-type: none"> 1 Bleeder screw 2 Ride control valve spool 3 Safety valve 4 Return flow to control valve block 5 Release valve | <ul style="list-style-type: none"> 6 Hydro accumulator relief valve 7 Ride control hydro accumulator connection 8 Connection to piston side of lift cylinder 9 Connection to ring side of lift cylinder |
|--|---|

Name	Test point
MX	Ride control hydro accumulator charge pressure

Tab. 198: Test points

BMK	Function
Y20	Solenoid for ride control

Tab. 199: Equipment codes

Stabilisation module is fitted on left in front section.

sah01824

LBH/11835201/20/21+20191218_101659/en

060.9 Pipe break protection

060.9.1 Pipe break protection: overview

Valid for: L580-1464;

This equipment is optional.

1 Layout

Pipe break protection consists of following components:

- One valve block for pipe break protection on each hydraulic cylinder of working hydraulics ([For more information see: 060.9.2 Valve block for pipe break protection, page 060-56](#))
- Ride control release solenoid valve ([For more information see: 060.9.3 Ride control release solenoid valve, page 060-57](#))

080.2 Hydraulic system: overview

Valid for: L580-1464/50693-;

1 Layout

The hydraulic system consists of following assemblies:

- Hydraulic tank
- Hydraulic cooling control system
- Working hydraulics
- Steering system
- Brake system
- Hydraulic transmission control system

2 Function

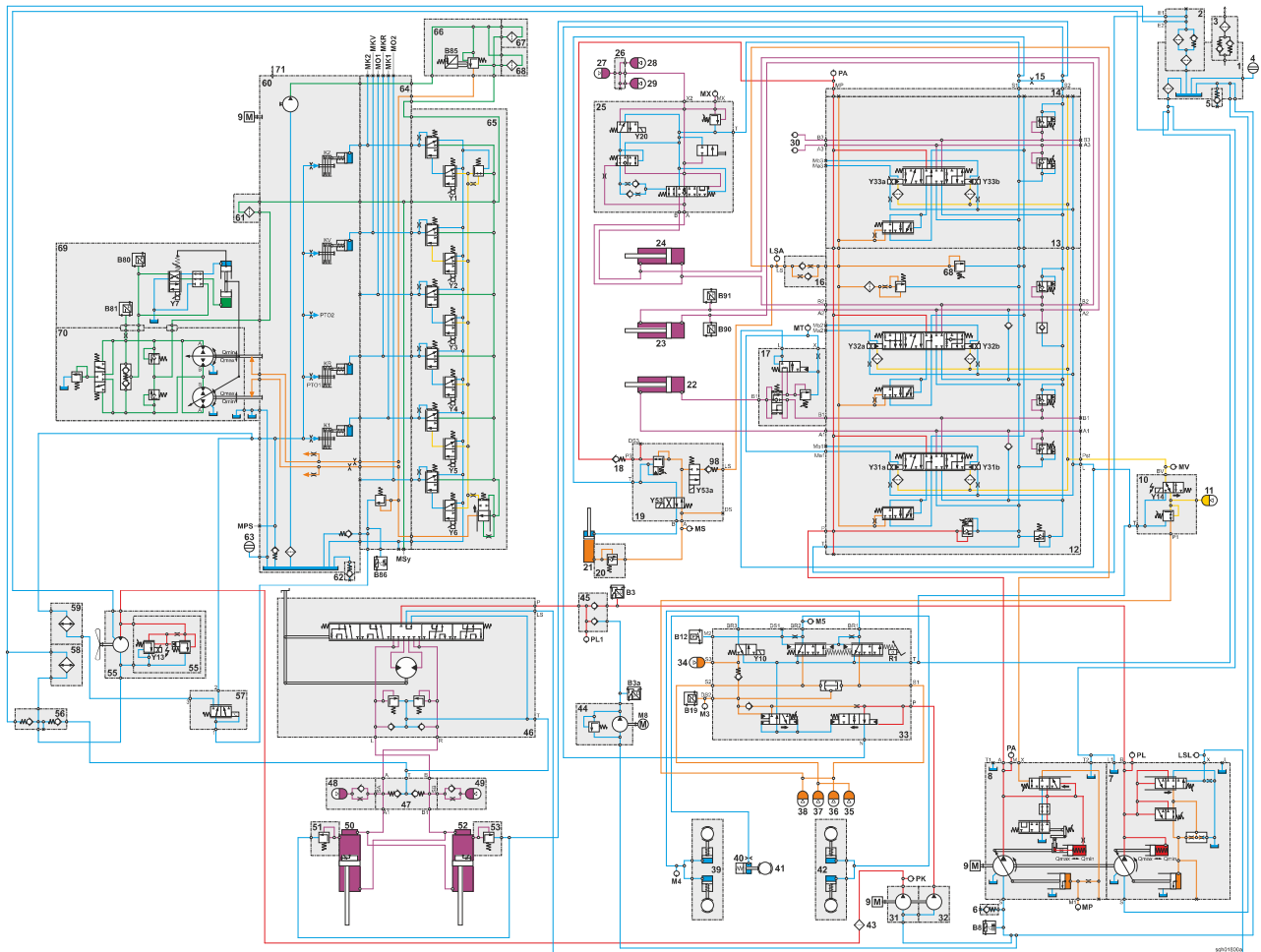

Fig. 439: Diagram of hydraulic system (diesel engine is running)

- | | | |
|-------------------------|-----------------------------------|--|
| 1 Hydraulic tank | 25 Stabilization module | 49 Steering damper hydro accumulator |
| 2 Return filter | 26 Hydro accumulator block | 50 Left steering cylinder with stroke limit damping |

See next page for continuation of the image legend

LBH11835201/20/21+20191218_101659/en

2.2 Pressure equalisation

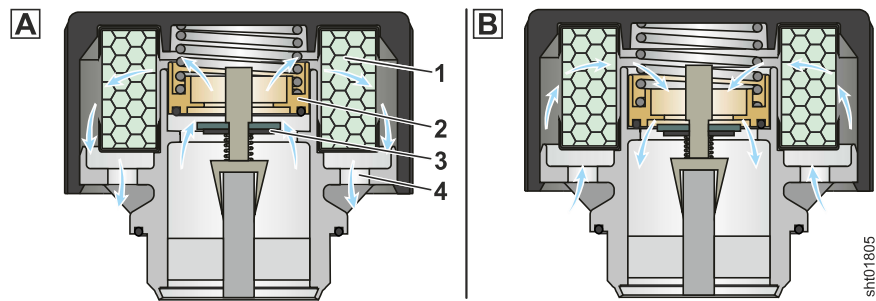

Fig. 450: Breather filter under excess pressure and with insufficient pressure

- | | | | |
|---|-----------------------|---|----------------------|
| 1 | Fine filter | 3 | Inlet valve 0.03 bar |
| 2 | Outlet valve 0.65 bar | 4 | Opening |

2.2.1 Excess pressure in the steel tank

Excess pressure in the steel tank can be caused by increased oil temperature or by the hydraulic cylinders retracting.

At a certain excess pressure, the outlet valve **2** opens. Air can then escape via the fine filter **1** and the opening **4** to the outside.

2.2.2 Insufficient pressure in the steel tank

Insufficient pressure in the steel tank can be caused by decreasing oil temperature or by the hydraulic cylinders extending.

Once the pressure falls below a certain level, the inlet valve **3** opens. Air can then flow into the steel tank via the opening **4** and the fine filter **1**.

Name	Test point	Name	Test point
LSL	Load sensing signal for steering pump (option)	PL1	High pressure for steering pump or emergency steering pump

Tab. 222: Test points

BMK	Function	BMK	Function	BMK	Function
B3	Emergency steering pressure switch	B3a	Emergency steering check pressure switch	M8	Electric motor for emergency steering pump

Tab. 223: Equipment codes

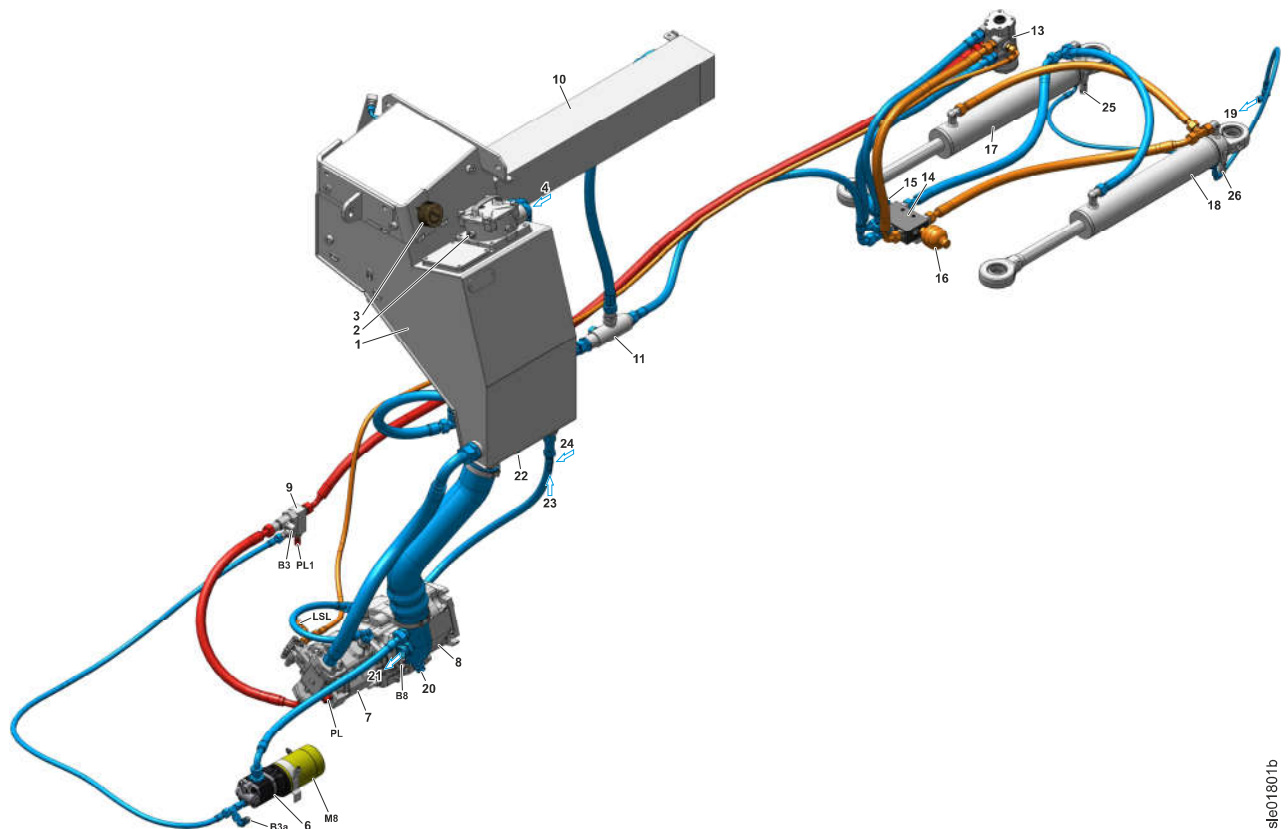

Fig. 455: Steering system (steering to left) (from rear right)

- | | | |
|---|--|--|
| 1 Hydraulic tank | 10 Hydraulic oil cooler | 19 Return flow from pressure relief valves to control valve block |
| 2 Return filter | 11 Collector pipe | 20 Working pump suction port drain valve |
| 3 Breather filter | 13 Servostat | 21 Fan pump and brake pump suction port |
| 4 Return flow from control valve block | 14 Steering stabilization valve block | 22 Hydraulic tank drain valve |
| 6 Emergency steering pump | 15 Steering damper hydro accumulator | 23 Fan motor leak oil |
| 7 Steering pump | 16 Steering damper hydro accumulator | 24 Return flow from compact brake valve and pilot control |

See next page for continuation of the image legend

LBH/11835201/20/21+20191218_101659/en

sie01801b

090.4 Servostat

Valid for: L580-1464;

1 Layout

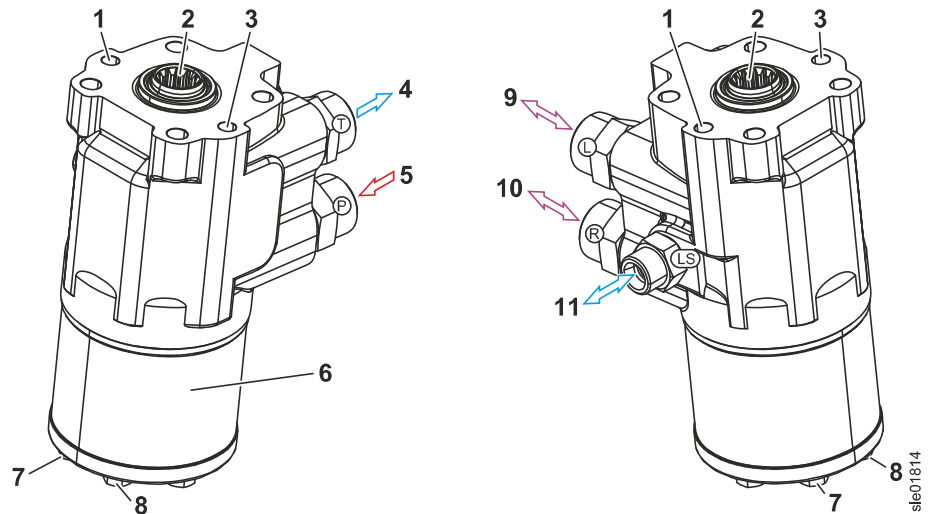

Fig. 465: Servostat (from front left and from front right)

- | | | | |
|---|---|----|--|
| 1 | Secondary pressure relief valve for steering to left | 7 | Feeder valve for steering to left |
| 2 | Connection for steering wheel shaft | 8 | Feeder valve for steering to the right |
| 3 | Secondary pressure relief valve for steering to right | 9 | Connection for steering to left |
| 4 | Return flow to collector pipe | 10 | Connection for steering to the right |
| 5 | Oil supply from steering pump | 11 | Load sensing signal to working hydraulics pump |
| 6 | Metering pump | | |

Servostat is bolted underneath cab floor.

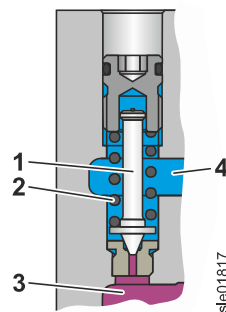

Fig. 466: Secondary pressure relief valve: secondary pressure relief valve

- | | | | |
|---|---------------------------------|---|---------------------------------|
| 1 | Secondary pressure relief valve | 3 | Connection to steering cylinder |
| 2 | Compression spring | 4 | Connection to tank port |

LBH/11835201/20/21+20191218_101659/en

BMK	Function	BMK	Function	BMK	Function
B3	Emergency steering pressure switch	B3a	Emergency steering check pressure switch	M8	Electric motor for emergency steering pump

Tab. 232: Equipment codes

Emergency steering system consists of following components:

- Hydraulic tank (For more information see: 080.3.1 Overview of hydraulic tank, page 080-8)
- Emergency steering pump (For more information see: 090.6.2 Emergency steering pump, page 090-30)
- Valve block for steering system
- Electrical controls (For more information see: Overview of electrical controls of emergency steering system, page 090-32)

2 Function

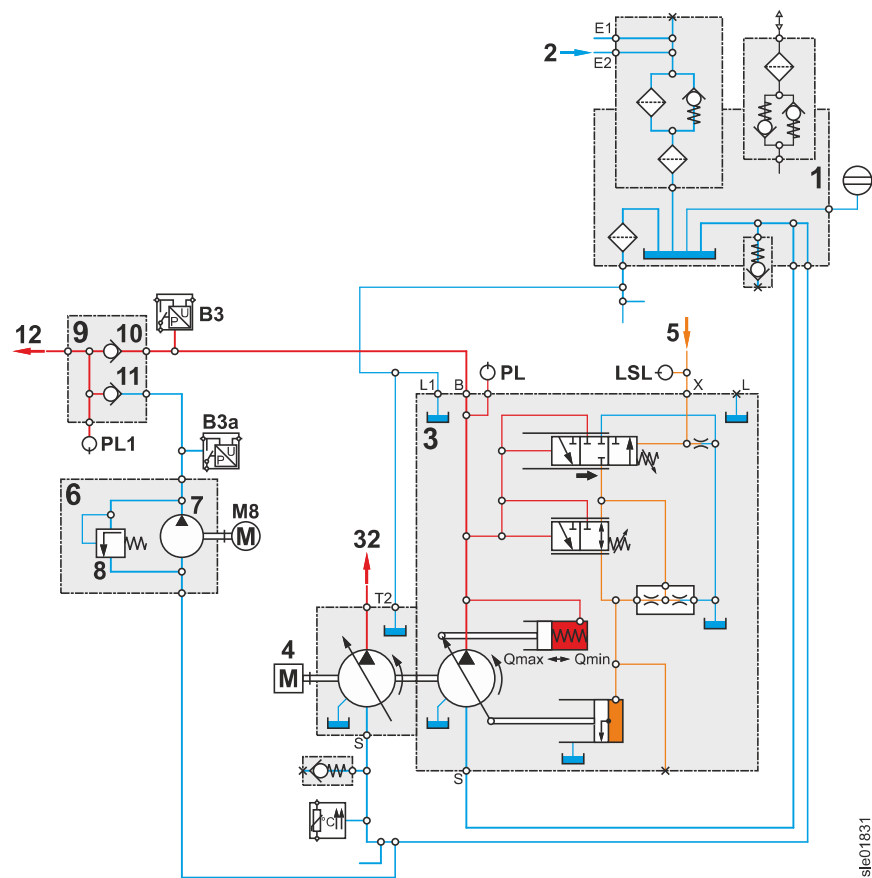

Fig. 479: Emergency steering: hydraulic diagram (emergency steering active)

- | | |
|--|--|
| 1 Hydraulic tank | 7 Gear pump |
| 2 Return flow from hydraulic oil cooler | 8 Pressure relief valve |
| 3 Steering pump | 9 Valve block for steering system |
| 4 Diesel engine | 10 Check valve |
| 5 Load sensing signal from servostat | 11 Check valve |
| 6 Emergency steering pump | 12 Oil supply to servostat |

LBH/11835201/20/21+20191218_101659/en

ste01831

090.7 Joystick steering

090.7.1 Overview of joystick steering

Valid for: L580-1464/0-50692;

This equipment is optional.

Version: control block for joystick steering generation 1 and hydro accumulator for steering damping with external throttle check valve.

1 Layout

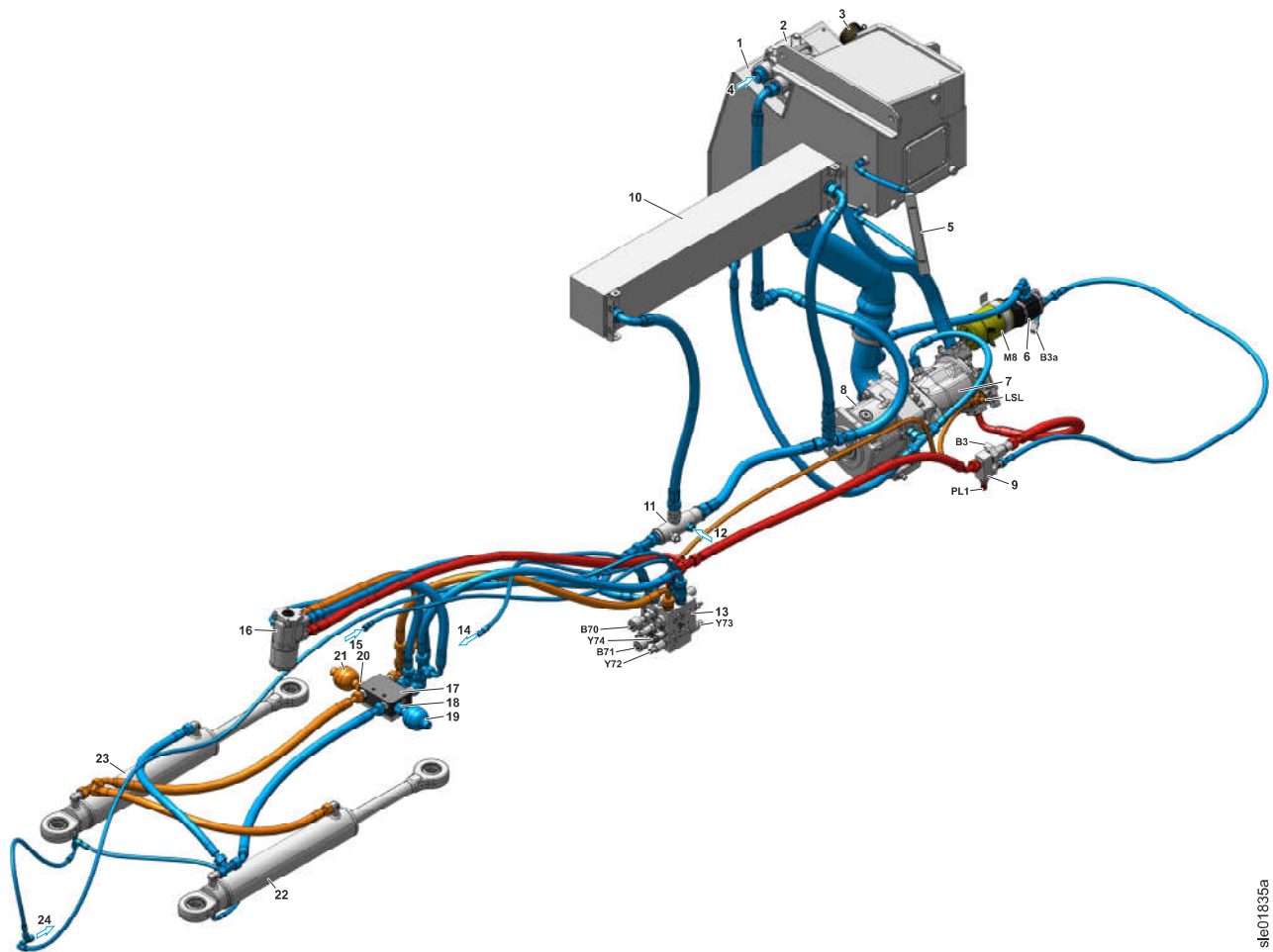

Fig. 490: Joystick steering system (steering to left) (from front left)

- | | | | | | |
|---|-----------------|----|---------------------------------|----|---|
| 1 | Hydraulic tank | 9 | Valve block for steering system | 17 | Steering stabilisation valve block |
| 2 | Return filter | 10 | Hydraulic oil cooler | 18 | Throttle check valve 2.0 mm (only with joystick steering) |
| 3 | Breather filter | 11 | Collector pipe | 19 | Steering damper hydro accumulator |

See next page for continuation of the image legend

LBH/11835201/20/21+20191218_101659/en

sle01835a

Name	Test point	Name	Test point	Name	Test point
LSL	Load sensing signal for steering pump	PL/	Steering pump high pressure	PL1	High pressure for steering pump or emergency steering pump

Tab. 248: Test points

BMK	Function	BMK	Function	BMK	Function
B3	Emergency steering pressure switch	M8	Electric motor for emergency steering pump	Y73	Proportional solenoid for steering to the right (emergency spool valve)
B3a	Emergency steering check pressure switch	Y70	Proportional solenoid for steering to the left (main spool valve)		
B8	Hydraulic oil temperature sensor	Y71	Proportional solenoid for steering to the left (spool valve for emergency steering function)		

Tab. 249: Equipment codes

The joystick steering consists of following components:

- Hydraulic tank (For more information see: [080.3.1 Overview of hydraulic tank, page 080-8](#))
- Steering pump (For more information see: [090.3 Steering pump, page 090-13](#))
- Servostat (For more information see: [090.4 Servostat, page 090-19](#))
- Joystick steering control valve block (For more information see: [090.7.4 Joystick steering control block, page 090-56](#))
- Steering cylinder (For more information see: [090.5.1 Steering cylinder, page 090-22](#))
- Steering stabilisation valve block (For more information see: [090.5.3 Steering stabilisation valve block, page 090-26](#))
- Emergency steering (For more information see: [090.6.1 Emergency steering overview, page 090-28](#))
- Hydraulic oil cooler

Name	Test point
M DMV1	Pressure to servo pressure reducing valve for main spool valve ^{A)}

Tab. 256: Test points

A) Thread M10x1

BMK	Function	BMK	Function	BMK	Function
B70	Main spool valve position sensor	Y70	Proportional solenoid for steering to the left (main spool valve)	Y73	Proportional solenoid for steering to the right (emergency spool valve)
B71	Emergency spool valve position sensor	Y71	Proportional solenoid for steering to the left (spool valve for emergency steering function)	Y74	Solenoid for safety circuit

Tab. 257: Equipment codes

The joystick steering control valve block is mounted in the vehicle frame on the left side of the vehicle, just in front of the rear axle.

2 Function

2.1 Basic function

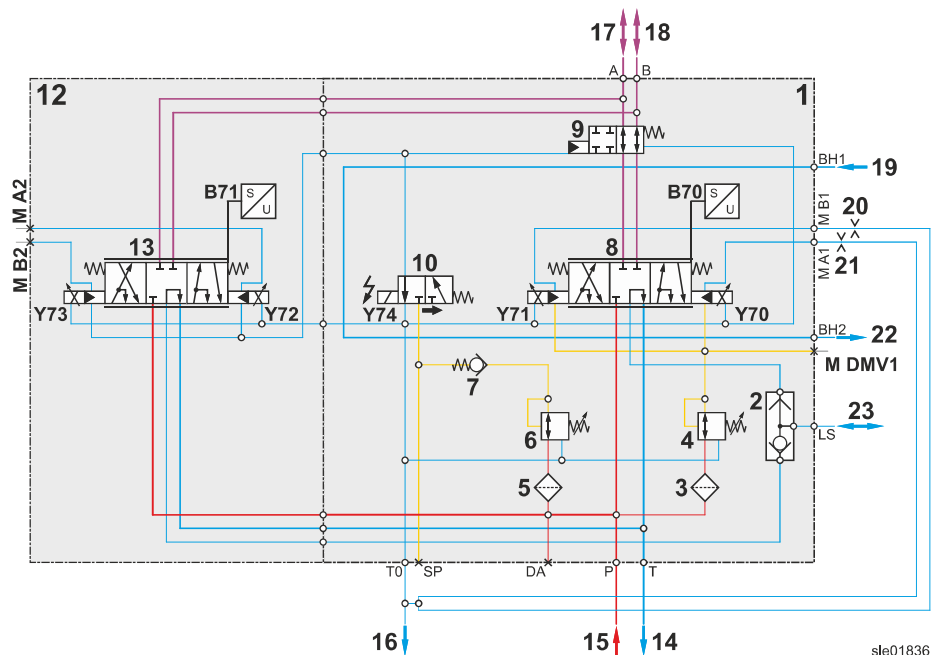

Fig. 499: Hydraulic diagram of joystick steering control valve block (joystick steering activated)

- 1** Joystick steering control block
- 2** Shuttle valve
- 13** Emergency spool valve
- 14** Return flow to collector pipe

See next page for continuation of the image legend

LBH/11835201/20/21+20191218_101659/en

2 Function

2.1 Joystick steering function in normal mode

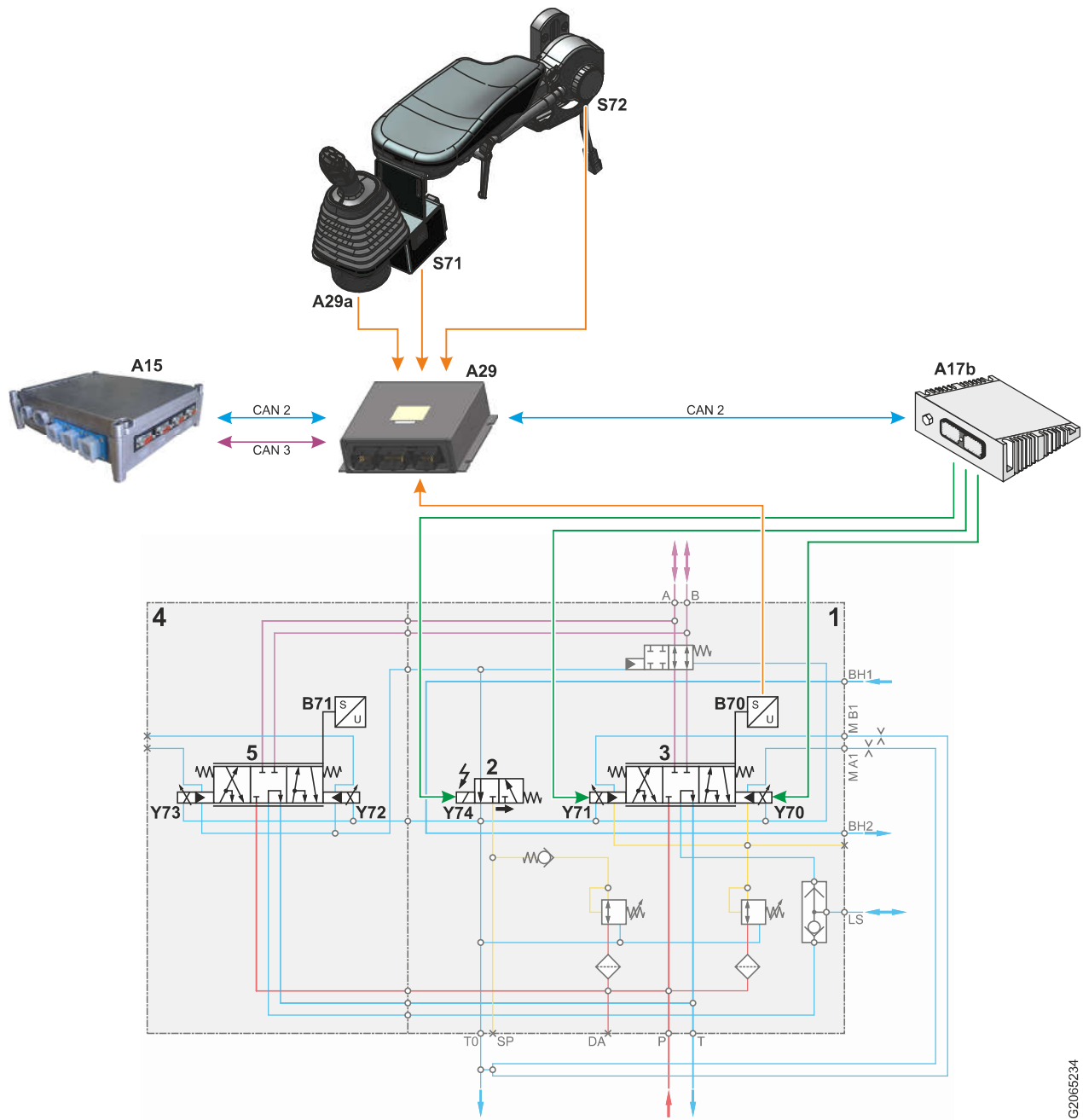

Fig. 504: Joystick steering function in normal mode

- | | | |
|---|--|---------------------------------------|
| <p>1 Joystick steering control block</p> <p>2 Solenoid valve for safety circuit</p> | <p>3 Main spool valve</p> <p>4 Control block section for emergency steering function</p> | <p>5 Emergency spool valve</p> |
|---|--|---------------------------------------|

LBH/11835201/20/21+20191218_101659/en

G2065234

BMK	Function	BMK	Function	BMK	Function
A15	Central control unit (Master4)	B71	Emergency spool valve position sensor	Y72	Proportional solenoid for steering to left (emergency spool valve)
A17b	Output module A17b	S71	Joystick steering switch	Y73	Proportional solenoid for steering to right (emergency spool valve)
A29	Joystick module	S72	Joystick steering switch (armrest)	Y74	Solenoid valve for safety circuit
A29a	Joystick electronics	Y70	Proportional solenoid for steering to left (main spool valve)		
B70	Main spool valve position sensor	Y71	Proportional solenoid for steering to left (spool valve for emergency steering function)		

Tab. 272: Equipment codes

In emergency mode, joystick steering is directly controlled via joystick module **A29**.

Safety circuit solenoid valve **Y74** is not energised. Control takes place using emergency spool valve **7**. Oil flow through main spool valve **5** is cut off.

Proportional control solenoid for steering to right (emergency spool valve) **Y72** and proportional control solenoid for steering to left (emergency spool valve) **Y73** are directly energised by joystick module **A29**.

Emergency spool valve positions sensor **B71** monitors position of emergency spool valve **7**. This signal is received by joystick module **A29**.

2.3 Function of joystick steering relay board A4b

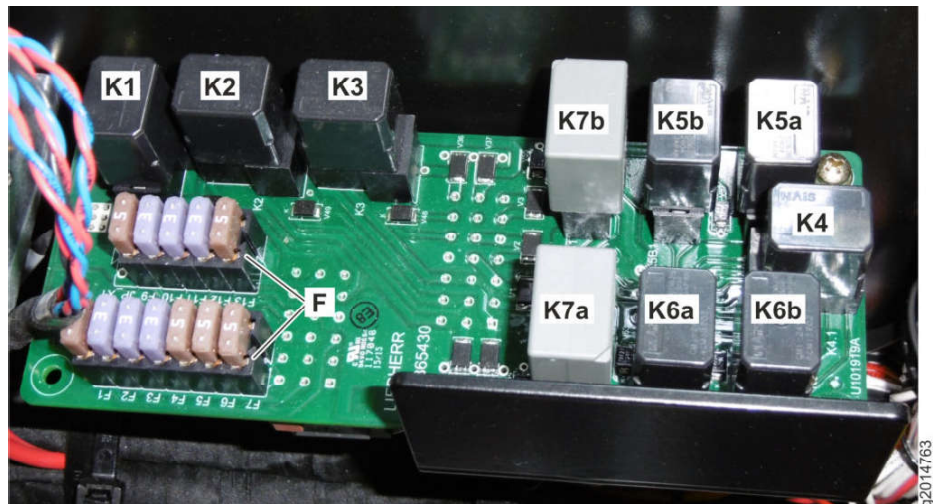

Fig. 510: Function of joystick steering relay board A4b

2 Function

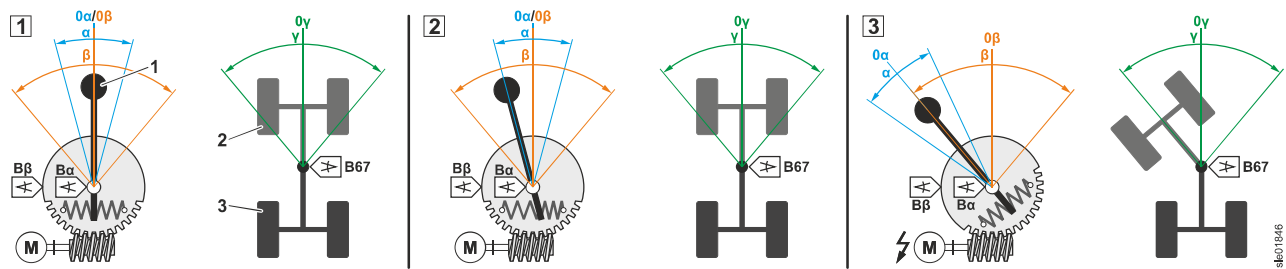

Fig. 516: Joystick with position tracking: function

- | | | |
|-----------------|--|--|
| 1 Joystick | α Steering angle | 0β Zero point of tracking angle |
| 2 Front section | 0α Zero point of steering angle | γ Articulation angle |
| 3 Rear section | β Tracking angle | 0γ Zero point of articulation angle |

BMK	Function	BMK	Function
B α	Angle sensor for steering angle	B67	Articulation angle sensor
B β	Angle sensor for tracking angle	M	Servo motor

Tab. 279: Equipment codes

If operator performs a steering movement, they move joystick 1 within steering angle α . This movement is detected by angle sensor for steering angle B α and passed on to control system.

Control system turns machine. Angle sensor for articulation angle B67 reports steering movement back to control system.

Control system then adapts zero of steering angle 0α to articulation angle γ . To this end, servo motor M changes zero point of steering angle 0α within tracking angle β .

- | | | |
|---|---|---|
| <p>7 Hydraulic tank drain valve</p> <p>8 Leak oil from steering pump and working pump</p> <p>9 Fan motor leak oil</p> | <p>16 Hydro accumulator for service brake (1st brake circuit)</p> <p>17 Hydro accumulator for service brake (2nd brake circuit)</p> <p>18 Hydro accumulator for service brake (1st brake circuit)</p> | <p>25 Front axle with service brake for 1st brake circuit</p> |
|---|---|---|

Name	Test point	Name	Test point	Name	Test point
M3	Service brake accumulator pressure	M4	Brake pressure in 1st brake circuit (front axle)	M5	Brake pressure in 2nd brake circuit (rear axle)

Tab. 284: Test points

BMK	Function	BMK	Function
B8	Hydraulic oil temperature sensor	B19	Brake accumulator pressure sensor
B12	Brake light pressure switch	R1	Inching function angle sensor

Tab. 285: Equipment codes

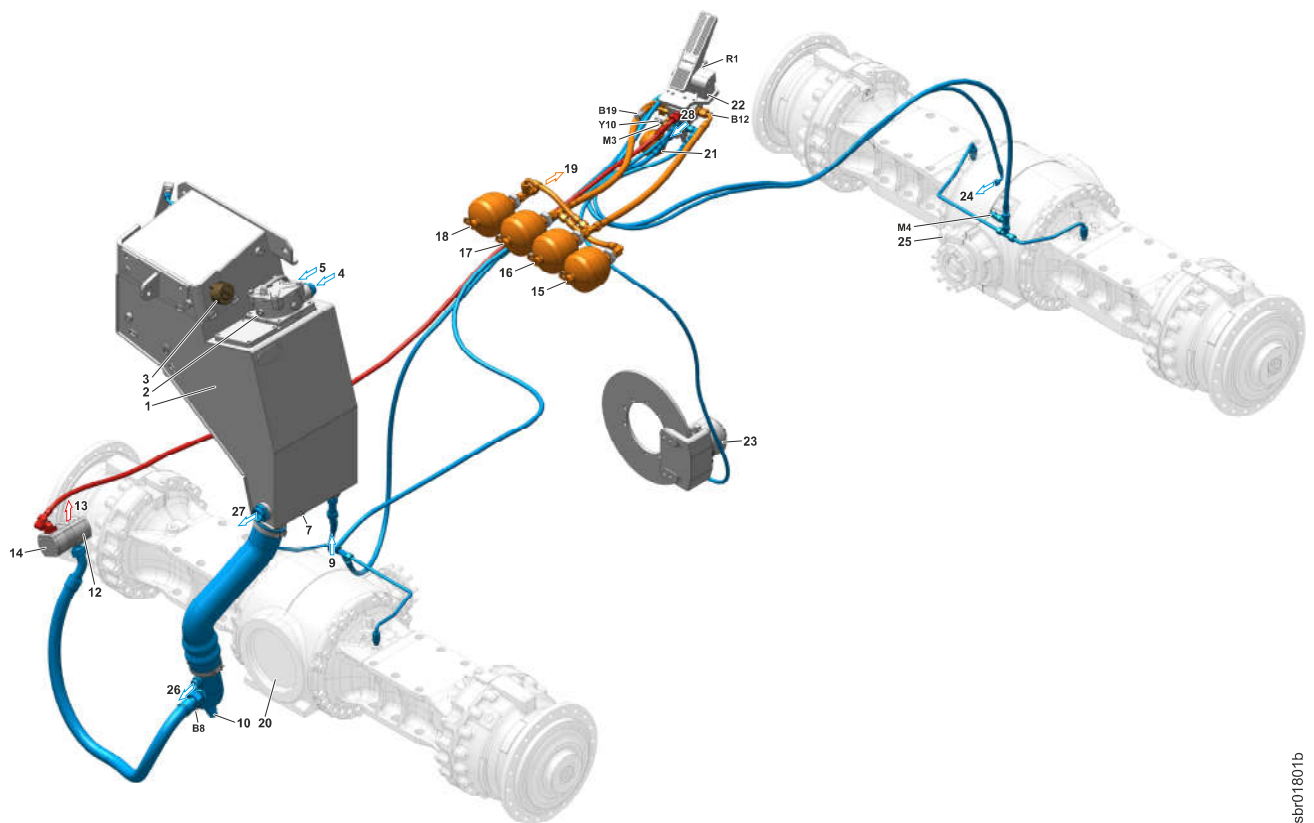

Fig. 521: Brake system (parking brake activated) (from rear right)

- | | | |
|---|---|---|
| <p>1 Hydraulic tank</p> <p>2 Return filter</p> <p>3 Breather filter</p> <p>4 Return flow from control valve block</p> | <p>13 Fan motor oil supply</p> <p>14 Brake pump</p> <p>15 Hydro accumulator for service brake (2nd brake circuit)</p> <p>16 Hydro accumulator for service brake (1st brake circuit)</p> | <p>22 Compact brake valve</p> <p>23 Parking brake</p> <p>24 Return flow to control valve block (housing preheating)</p> <p>25 Front axle with service brake for 1st brake circuit</p> |
|---|---|---|

See next page for continuation of the image legend

LBH/11835201/20/21+20191218_101659/en

sbr01801b

2.3.1 Hydro accumulators are fully charged

When hydro accumulators are charged up to cut-out pressure, system pressure pushes piston **3** and pilot valve **10** against regulating spring **1**.

Pilot valve **10** separates accumulator charge valve **8** from system pressure and connects it to return line to leak oil strainer **11**. This means oil from brake pump **12** pushes accumulator charge valve **8** against compression spring **9**. Oil from brake pump **12** flows to control valve block housing preheating **13**.

2.3.2 Hydro accumulators are being charged

Via piston **3**, brake system pressure acts on pilot valve **10**. If system pressure drops to cut-in pressure, regulating spring **1** pushes pilot valve **10** against system pressure.

Pilot valve **10** connects accumulator charge valve **8** to system pressure. This results in accumulator charge valve **8** being closed by system pressure and compression spring **9**.

Oil from brake pump **12** flows via inverted shuttle valve **4** and parking brake check valve **7** to hydro accumulator.

2.4 Inching function

Inching function angle sensor R1 is connected to inching brake pedal. In first two thirds of pedal movement, only inching function is operated.

Inching function angle sensor R1 is a two-channel sensor. It issues two mixed current signals between 6 mA and 18 mA.

When inching, central control unit reduces target speed and tractive force. Machine is slowed down by engine braking effect.

2.1 Fuse boards

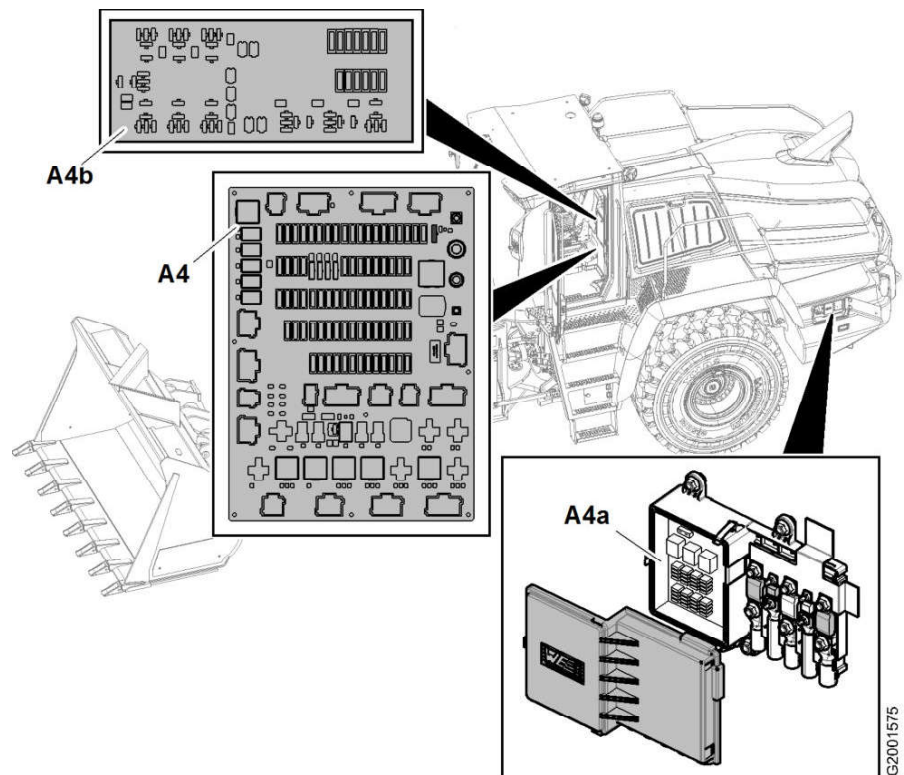

Fig. 536: Fuse boards

Fuse boards **A4** and **A4b** are mounted on rear wall of operator's cab.

Fuse board **A4b** is only installed if machine is equipped with joystick steering.

Fuse board **A4a** is installed in left ballast weight.

12418288 105
 ITEM CODE DRAWING NUMBER
 1333 90100 01 00
 1333 90100 01 00
 PROJECT

CONTENTS	PAGE
ACTUATORS SENSORS ENGINE	/55
ACTUATORS SENSORS ENGINE	/56
ACTUATORS SENSORS ENGINE	/57
Albonair SCR MODULE	/54
DISPLAY UNIT CAN BUS 3	/40
WORKING HYDRAULICS LOCKOUT; LFD; POSITIONING SYSTEM;	/42
WORKING PROJECTOR REAR REAR	/33
WORKING PROJECTOR FRONT CAB	/32
BMK-INDEX	/6
BMK-INDEX	/7
BMK-INDEX	/8
BMK-INDEX	/9
BMK-INDEX	/10
BMK-INDEX	/11
BMK-INDEX	/12
BMK-INDEX	/13
BMK-INDEX	/14
BMK-INDEX	/15
BMK-INDEX	/16
BMK-INDEX	/17
BMK-INDEX	/18
BMK-INDEX	/19
BMK-INDEX	/20
BMK-INDEX	/21
BMK-INDEX	/22
BMK-INDEX	/23
CAN BUS 1 ; CAN BUS 4	/39
CAN BUS OVERVIEW DIAGRAM	/1
CAN PILOT CONTROL UNIT; OPTIONS PUSH-BUTTON SWITCH; CAN BUS 2	/41
DIAGNOSTIC PLUG MOTOR CONTROL	/62
ANGLE SENSOR INCH-SPEED-PEDAL	/58
ELECTRICAL HOOD OPENING	/64
TRANSMISSION	/45
INDOOR LIGHTING; COMPRESSOR SEAT; DOOR CONTACT SWITCH	/28
INDOOR LIGHTING; COMPRESSOR SEAT; DOOR CONTACT SWITCH	/29
CAMERA	/38

CONTENTS	PAGE
AIR CONDITIONING SYSTEM SYSTEM SIDE	/61
AIR CONDITIONING SYSTEM EQUIPMENT / MACHINES SIDE	/59
FUEL LEVEL SENSOR; HYDRAULIC OIL TEMPERATURE ;	/48
KEY ; HANDOUT VIA	/5
STEERING COLUMN SWTCH ; STOP LIGHT ; NUMBER PLATE LIGHT	/30
LITU	/63
VENTILATOR CONDENSER	/60
SOLENOID VALVES WORKING HYDRAULICS	/43
RETROFIT KIT DOOR CONTACT SENSOR	/126
EMERGENCY STEERING PUMP; PRESSURE SWITCH EMERGENCY STEERING PUMP	/26
OPTION Vcc ADDITIONAL MODULE OUTPUT 2	/122
OPTION ADDITIONAL MODULE OUTPUT 2 GENERAL OUTLAY	/121
OPTION WORKING BASKET	/123
OPTION WORKING PROJECTOR a. LAMP HOLDER	/82
OPTION WORKING PROJECTOR REAR CAB	/81
OPTION LIGHTING CONTROL	/116
OPTION LIGHTING CONTROL ARTICULATED JOINT	/117
OPTION REFUELLING PUMP; EXTERNAL ELECTRICAL SOCKET 24V	/87
OPTION BLAXTAIR RÜCKFAHRWARNSYSTEM	/125
OPTION CAN BUS 2 ADDITIONAL MODULE	/88
OPTION CAN BUS JOYSTICK STEERING	/92
OPTION ELECTRICAL MIRROR ADJUSTMENT	/86
OPTION DRIVER'S SEAT WITH 3-POINT BELT	/110
OPTION EXTERNAL STARTING CABLE 24V	/107
OPTION RADIO PREPARATION LIEBHERR WHEEL LOADER	/108
OPTION GEROTOR STEERING	/98
OPTION GRABBER CAMERA LOG HANDLER	/151
OPTION MAIN VALVEL; EMERGENCY VALVE	/99
OPTION HORN OPERATION VIA ADDITIONAL KEY	/85
OPTION JOYSTICK STEERING	/100
OPTION COUNTRY-SPECIFIC TYPEEXECUTION	/120
OPTION LED DRIVING LIGHT	/119
OPTION LH WEIGHING DEVICE; AIR FILTER VACUUM SWITCH G1	/114
OPTION AUTOMATIC RUN-OUT	/102
OPTION AUTOMATIC RUN-OUT	/103
OPTION AUTOMATIC RUN-OUT	/104

12418288
ITEM CODE
DRAWING INDEX 105

1333 9010 01 00
DRAWING NUMBER

PROJECT
Stufe 4 GG_23.11.18 E_Hauptschalter

ISO 15715: The reproduction, distribution and utilization of this document as well as its contents to others without express authorization is prohibited.

BMK	SYSTEM	LOCATION	FUNCTION	PAGE
-F53	=A4	+K	LOW BEAM/DRIVING LIGHT	/30.B4
-F54	=A4	+K	LOW BEAM/DRIVING LIGHT	/30.B5
-F55	=A4	+K	PROFILE LIGHT-/IDENTIFICATION-/CONTEUR LIGHT	/30.B4
-F56	=A4	+K	PROFILE LIGHT-/IDENTIFICATION-/CONTEUR LIGHT	/30.B6
-F57	=A4	+K	HOOD	/64.A2
-F62	=A4	+K	AIR CONDITIONING SYSTEM	/59.A3
-F63	=A4	+K2	AUXILIARY HEATER	/105.A5
-F64	=A4	+K	Vcc K14 EMERGENCY STEERING PUMP	/26.A4
-F65	=A4	+K	VOLTAGE CONVERTER (RADIO)	/37.A2
-F66	=A4	+K2	SCR AIR DRIER	/53.A6
-F68	=A4	+K	WORKING PROJECTOR REAR AMI CAB ROOF	/81.B2
-F69	=A4	+K	WORKING PROJECTOR REAR AMI CAB ROOF	/81.B5
-F70	=A4	+K	PROFILE LIGHT-/IDENTIFICATION-/CONTEUR LIGHT	/30.E2
-F71	=A4	+K	IGNITION STARTER SWITCH BYPASS	/24.C1
-F72	=A4	+K	LOW BEAM/DRIVING LIGHT	/30.B5
-F73	=A4	+K	LOW BEAM/DRIVING LIGHT	/30.B5
-F74	=A4	+K	COMPRESSOR SEAT	/28.B4
-F75	=A4	+K	USB LADEDOSE	/28.B4
-F208	=RH.	+K2	DIESEL PREHEATING	/62.B6
-F218	=K	+K2,RH	LIGHTING CONTROL E18, E18a	/117.B6
-F238	=RH	+K2	QUICK-CHANGE DEVICE	/101.B2
-F255	=K	+K	ELECTRICAL SOCKET 24V	/87.B7
-F263	=RH.	+K2	SEAT BELT	/109.B3
-F263a	=RH.	+K	SEAT BELT	/109.C1
-F275	=K	+K,RH	REVERSING OBSTACLE DETECTOR	/84.D4
-F276	=RH.	+K2.	VOLTAGE CONVERTER RADIO	/108.A5
-F277	=RH	+K2,RH,H	KL. 15 RADIO	/108.C5
-F278	=RH	+K2,R,H	KL. 30 RADIO	/108.C5
-F301	=K	+K2	FUSE WARNING LIGHT	/127.B3
-F500	=RH.	+K2	REFUELLING PUMP	/87.B1
-F501	=RH.	+K2	REFUELLING PUMP	/87.B5
-F503	=K	+K	DISPLAY SKY VIEW	/124.A2
-F504	=K	+K	CONNECTOR ELECTRONICS SKY VIEW	/124.A4
-F610	=K	+K	ADDITIONAL MODULE OUTPUT 2	/122.B2
-F611	=K	+K	ADDITIONAL MODULE OUTPUT 2	/122.B3
-F612	=K	+K	ADDITIONAL MODULE OUTPUT 2	/122.B4

BMK	SYSTEM	LOCATION	FUNCTION	PAGE
-F613	=K	+K	ADDITIONAL MODULE OUTPUT 2	/122.B5
-F614	=K	+K	ADDITIONAL MODULE OUTPUT 2	/122.B5
-F615	=K	+K	REAR AREA MONITORING	/125.B4
-F616	=K	+K	REAR AREA MONITORING	/125.B4
-G1	=B	+B	BATTERY	/24.F2
-G2	=B	+B	BATTERY	/24.F3
-G2.30	=M	+M	KL. 30 ENGINE START	/107.D3
-G3	=M	+M	ALTERNATOR	/24.E6
-H15	=B	+B	LED MASTER SWITCH STATUS	/24.E5
-H15	=V	+V1	BLINKER LEFT 24V - 21W ORANGE	/30.E4
-H15.X	=B	+B	PLUG H15	/24.E5
-H16	=V	+V1	BLINKER RIGHT 24V - 21W	/30.E6
-H22b	=H	+H	BEACONLIGHT AT REAR	/83.E7
-H22b.X	=H	+H	CONNECTOR H22b	/83.E7
-H22l	=K	+K3	BEACONLIGHT	/36.E2
-H22l.X1	=K	+K	PLUG H22l	/36.E2
-H22l.X1.B	=K	+K	CONNECTOR -H22l.X1.B	/149.E6
-H22l.X1.S	=K	+K	CONNECTOR -H22l.X1.S	/149.E6
-H22r	=K	+K3	BEACONLIGHT	/36.E3
-H22r.X1	=K	+K3	CONNECTOR H22r	/36.E3
-H22r.X1.B	=K	+K	CONNECTOR -H22r.X1.B	/149.E7
-H22r.X1.S	=K	+K	CONNECTOR -H22r.X1.S	/149.D7
-H22r.X2	=K	+K3	PLUG H22r	/36.E3
-H22r.X2.B	=K	+K	CONNECTOR -H22r.X1.B	/149.E7
-H22r.X2.S	=K	+K	CONNECTOR -H22r.X1.S	/149.E7
-H23	=K	+K	VERSION BEACONLIGHT	/109.E2
-H23.X1	=K	+K	CONNECTOR H23	/109.E2
-H23.X2	=K	+K	CONNECTOR H23	/109.E2
-H40	=K	+K2	BUZZER	/49.C3
-H40.X1	=K	+K2	PLUG BUZZER	/49.C3
-H40.X2	=K	+K2	PLUG BUZZER	/49.D3
-H47	=K	+K2	CHARGE CONTROL	/28.B8
-H50	=V	+V1	PROFILE LIGHT/PARKING LIGHT LEFT FRONT 24V - 4W	/30.E4

MACHINE TYPE
LIDOS UNIT

SERIAL NUMBER
XXXXX

LIEBHERR
FACTORY LBH

BMK-INDEX
E PLAN

PAGE 12 OF

CREATION DATE 26.04.2019 10:08

WORKING PROJECTOR FRONT

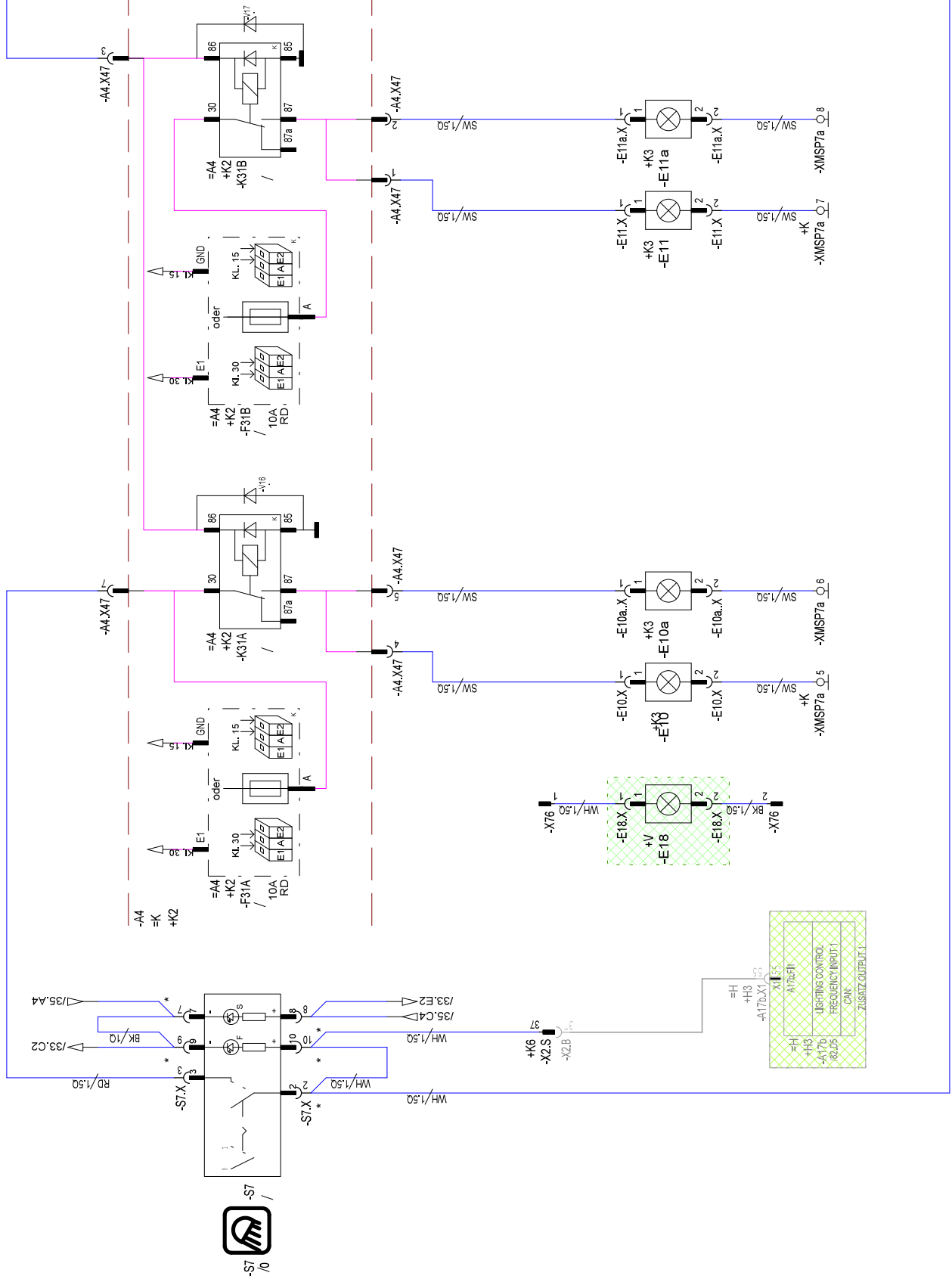

12418288

ITEM CODE 105 DRAWING INDEX

PROJECT Stufe 4 GG_23.11.18 E_Hauptschalter 1333 90100 01 00

DRAWING NUMBER 1333 90100 01 00

Violations require compensation. All rights reserved in the case of patent, utility, model or design registration.

MACHINE TYPE
LIDOS UNIT

SERIAL NUMBER
XXXXX

WORKING PROJECTOR FRONT CAB
E PLAN

PAGE 32 OF
CREATION DATE 26.04.2019 10:08

PROJECT: **Stufe 4 GG_23.11.18 E_Hauptschalter**
 DRAWING NUMBER: **1333 9010 01 00**
 DRAWING INDEX: **105**
 ITEM CODE: **12418288**

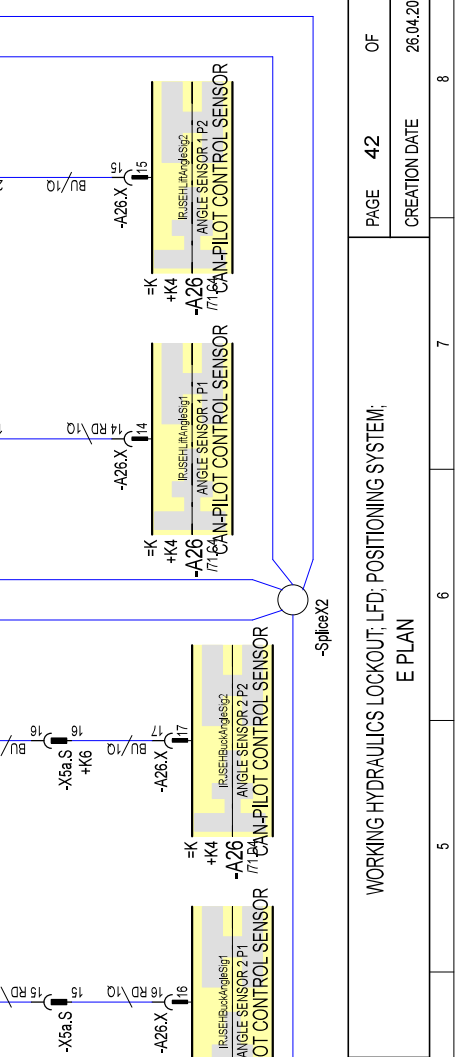
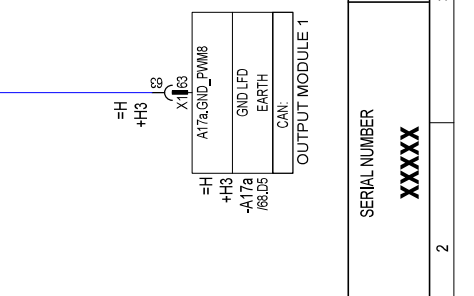
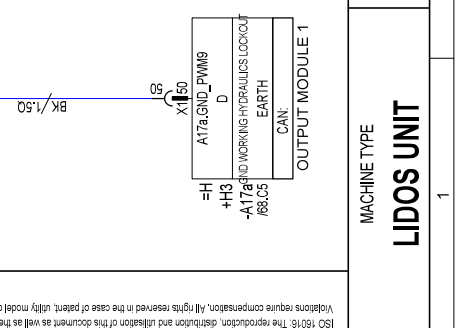
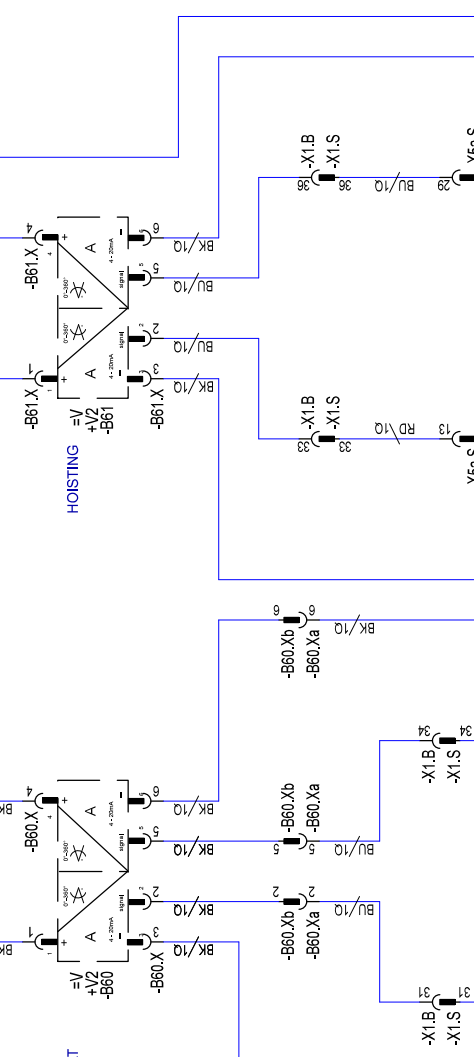
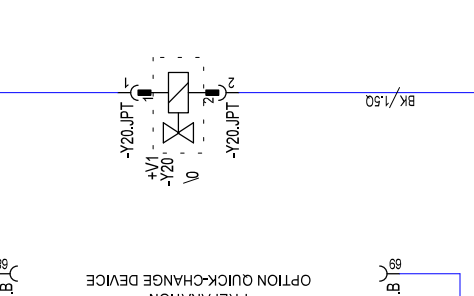
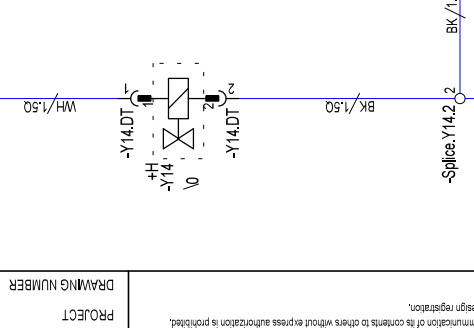
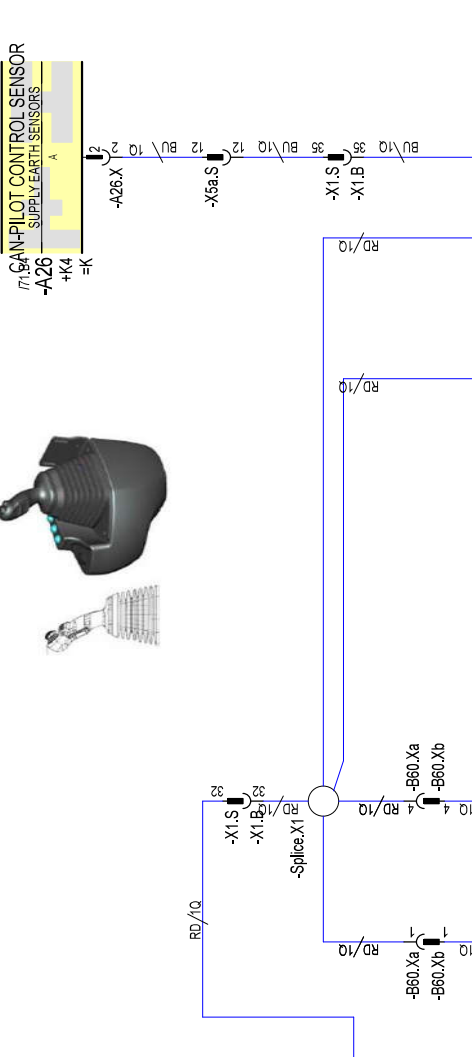
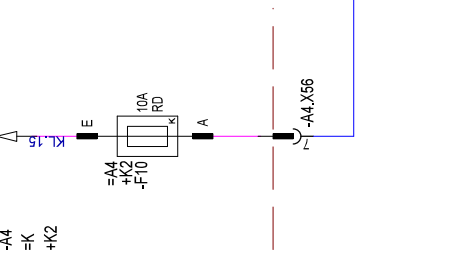
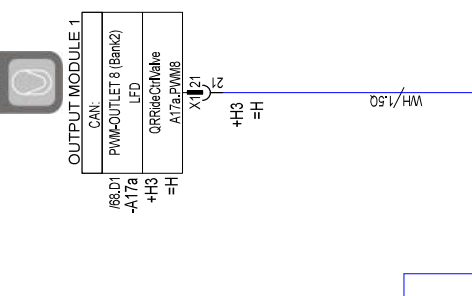
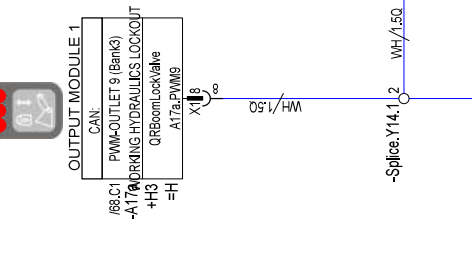

MACHINE TYPE: **LIDOS UNIT**

SERIAL NUMBER: **XXXXX**

WORKING HYDRAULICS LOCKOUT; LFD; POSITIONING SYSTEM;
 E PLAN

12418288
ITEM CODE

1333 90100 01 00
DRAWING NUMBER

Stufe 4 GG_23.11.18 E_Hauptschalter
DRAWING INDEX

105

ISO 15701:15. The reproduction, distribution and utilization of this document or its contents to others without express authorization is prohibited. Violations require compensation. All rights reserved in the case of patent, utility, model or design registration.

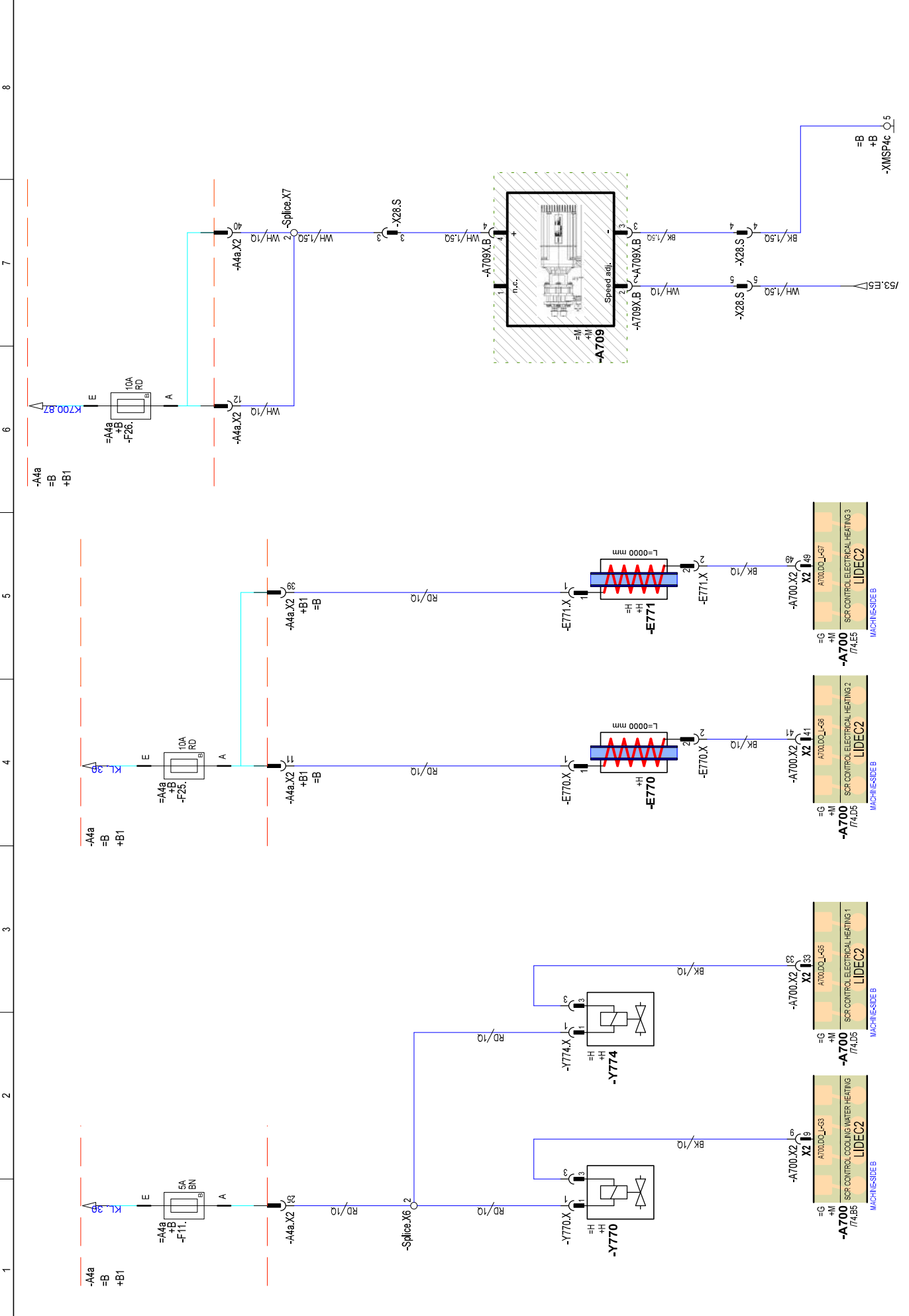

MACHINE TYPE
LIDOS UNIT

SERIAL NUMBER
XXXXX

LIEBHERR
FACTORY LBH

SUPPLY SCR HOSE HEATING; SCR WATER VALVES
E PLAN

PAGE 52 OF

CREATION DATE 26.04.2019 10:08

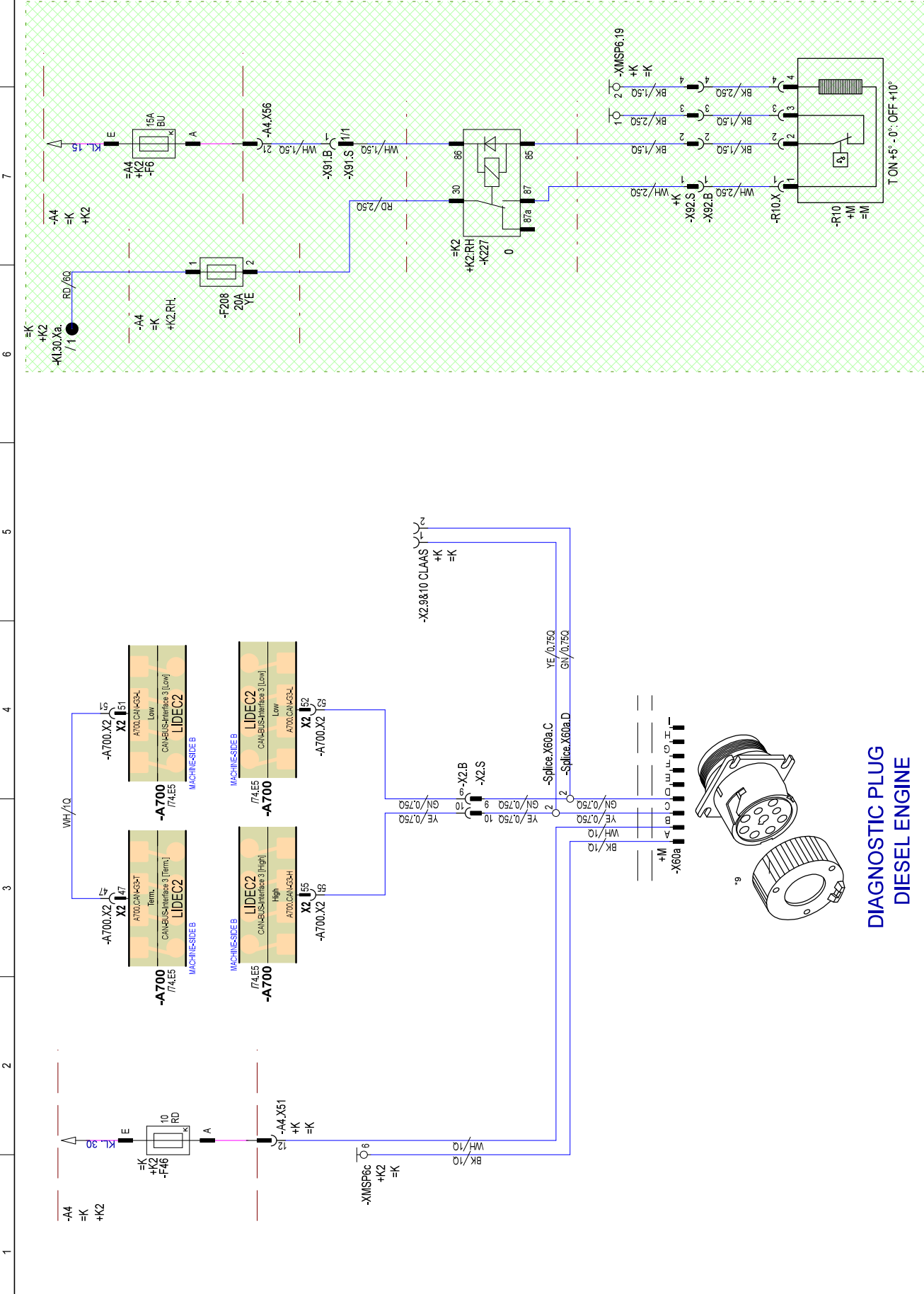

**DIAGNOSTIC PLUG
 DIESEL ENGINE**

Phys. Adr.	Blatt	EA	Beschreibung	Stecker	Pin	Phys. Adr.	Blatt	EA	Beschreibung	Stecker	Pin
A30.1			Vers. FROM SAT MODULE		1	A30.25			CANL1		25
A30.2			KL15 FOR SAT MODULE		2	A30.26			CANL2		26
A30.3			RESERVE		3	A30.27			-		27
A30.4	/63.F4		DCD SIGNAL		4	A30.28	/63.E2		V_IN (KL30)		28
A30.5	/63.F3		DTR SIGNAL		5	A30.29			GND		29
A30.6			NOT verwendet		6	A30.30			TXD-3		30
A30.7			EARTH		7	A30.31			CTS-3		31
A30.8	/63.F6		EARTH		8	A30.32			TXD-5		32
A30.9			SPEED DIESEL ENGINE		9	A30.33	/63.F5		TXD-0		33
A30.10			EARTH		10	A30.34	/63.F7		CTS SIGNAL		34
A30.11			RESERVE		11	A30.35			DIN1		35
A30.12			CAN.END		12	A30.36			GND		36
A30.13	/63.E1		INPUT KL15		13	A30.37			Analogeingang 1		37
A30.14			Schalttausgang 3A		14	A30.38			EARTH		38
A30.15			OUTLET KL30		15	A30.39			CAN High 1		39
A30.16			RXD SAT MODULE		16	A30.40			CAN High 2		40
A30.17			RTS SAT MODULE		17	A30.41			GND		41
A30.18	/63.F5		RXD Powermanagement		18	A30.42	/63.E2		EARTH		42
A30.19	/63.F8		RXD SIGNAL		19						
A30.20			RTS SIGNAL		20						
A30.21			DIGITAL INPUT 2		21						
A30.22			EARTH		22						
A30.23			Analogeingang 2		23						
A30.24			EARTH		24						

12418288
ITEM CODE

105
DRAWING INDEX

Projekt
Stufe 4 GG_23.11.18 E_Hauptschalter
1333 90100 01 00
DRAWING NUMBER

PROJECT
DRAWING NUMBER

ISO 15918: The reproduction, distribution and utilization of this document as well as the communication of its contents to others without express authorization is prohibited. Violations require compensation. All rights reserved in the case of patent, utility, model or design registration.

MACHINE TYPE
LIDOS UNIT

SERIAL NUMBER
XXXXX

LIEBHERR
FACTORY LBH

OPTION WORKING PROJECTOR a. LAMP HOLDER
E PLAN

PAGE 82 OF
CREATION DATE 26.04.2019 10:08

WORKING PROJECTOR FRONT

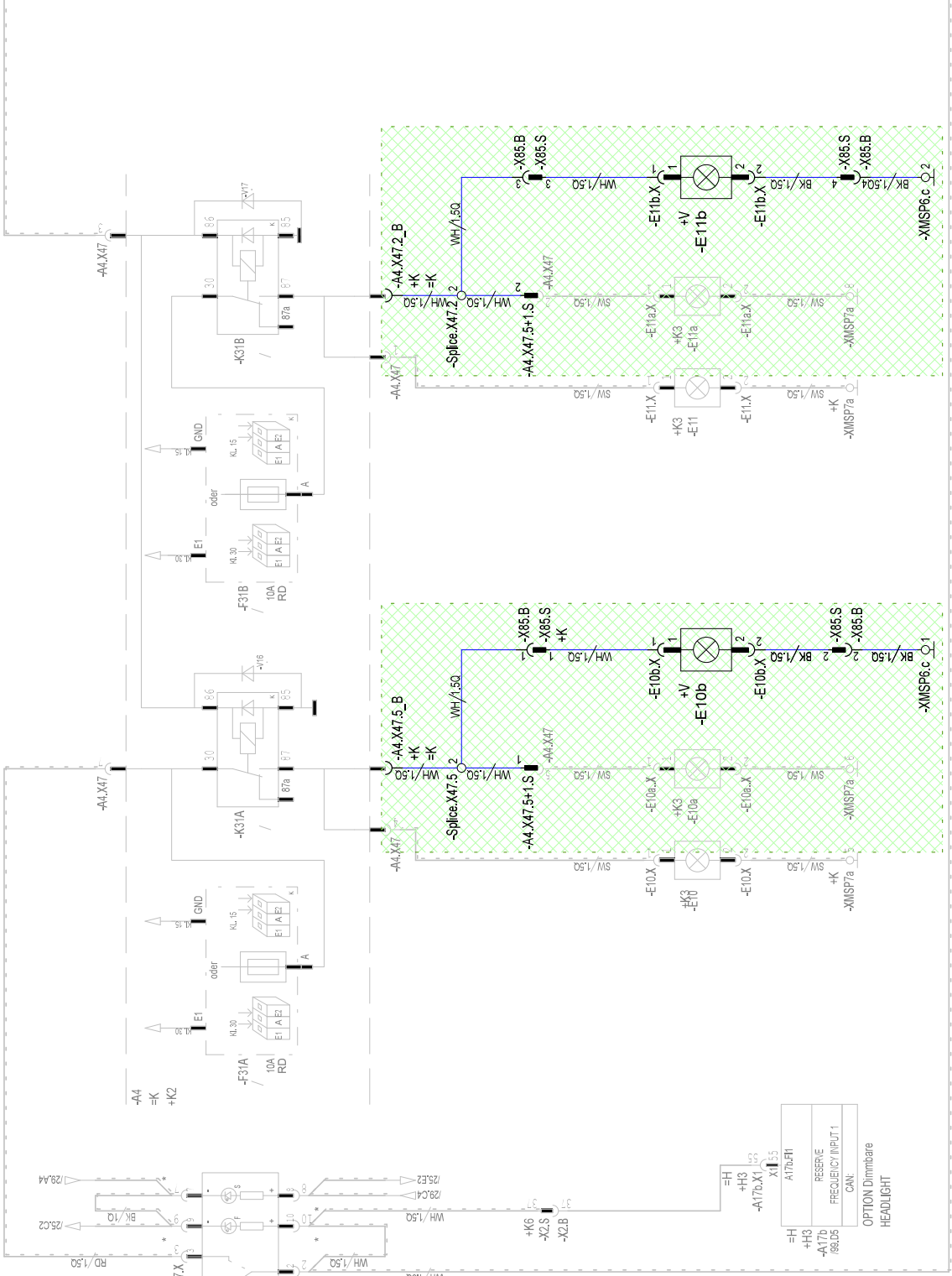

1 2 3 4 5 6 7 8

1 2 3 4 5 6 7 8

MACHINE TYPE
LIDOS UNIT

SERIAL NUMBER
XXXXX

LIEBHERR
 FACTORY LBH

OPTION CAN BUS JOYSTICK STEERING
 E PLAN

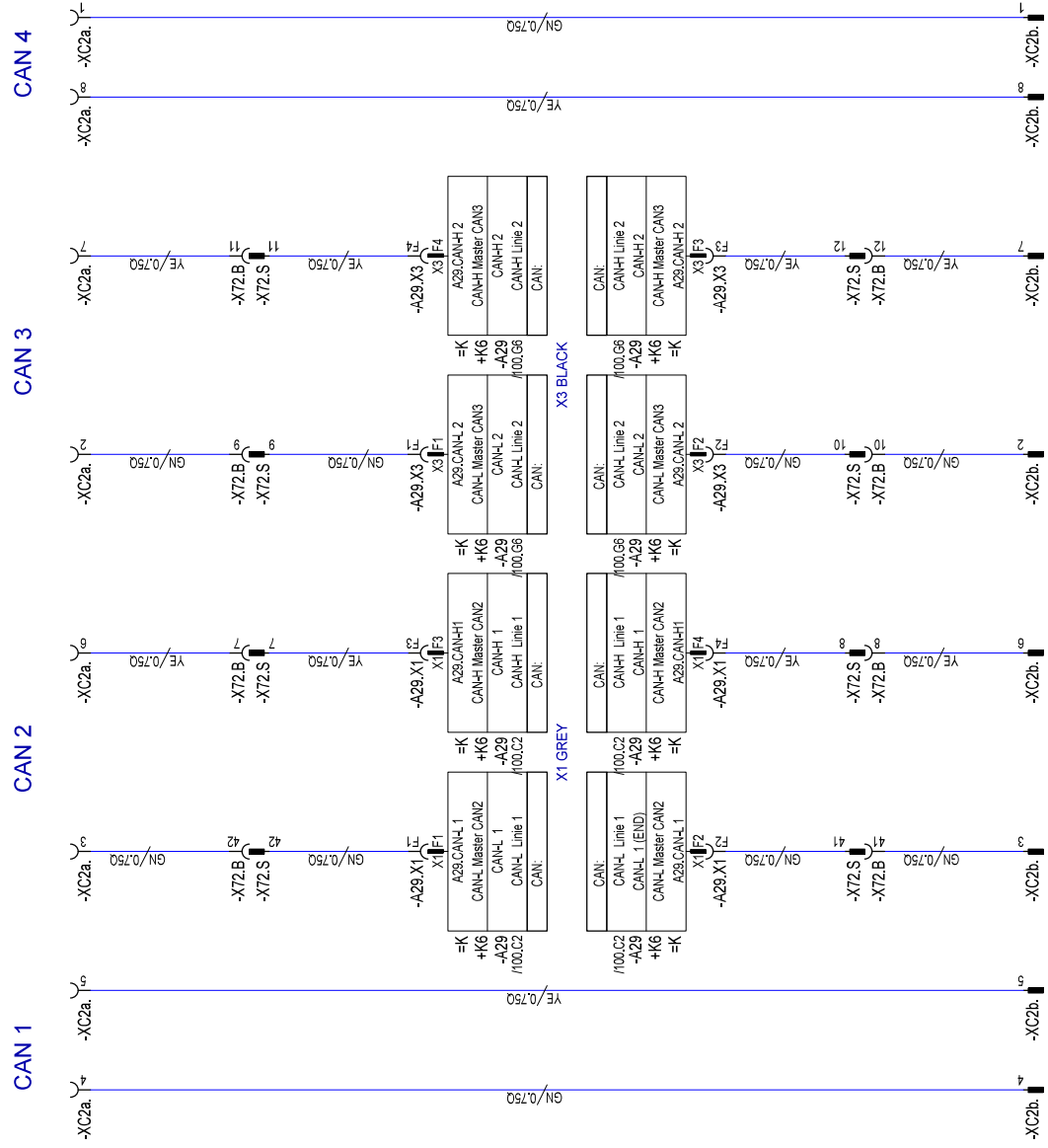

1 2 3 4 5 6 7 8

A B C D E F

12418288
ITEM CODE

105
DRAWING INDEX

1333 90100 01 00
DRAWING NUMBER

PROJECT
Stufe 4 GG_23.11.18 E_Hauptschalter

ISO 15705: The reproduction, distribution and utilization of this document as well as the communication of its contents to others without express authorization is prohibited. Violations require compensation. All rights reserved in the case of patent, utility model or design registration.

1 2 3 4 5 6 7 8

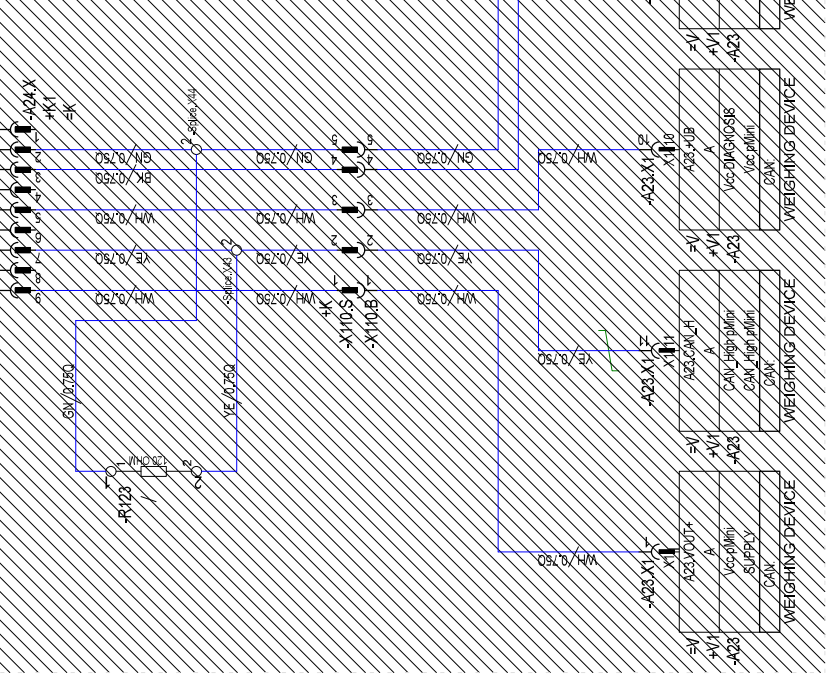
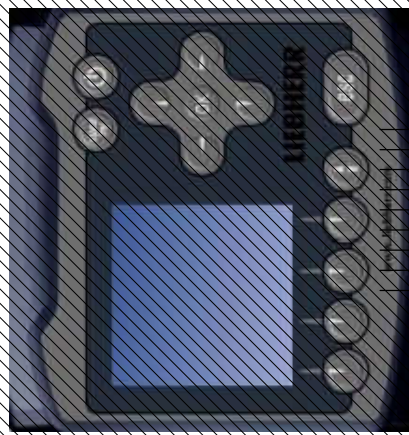
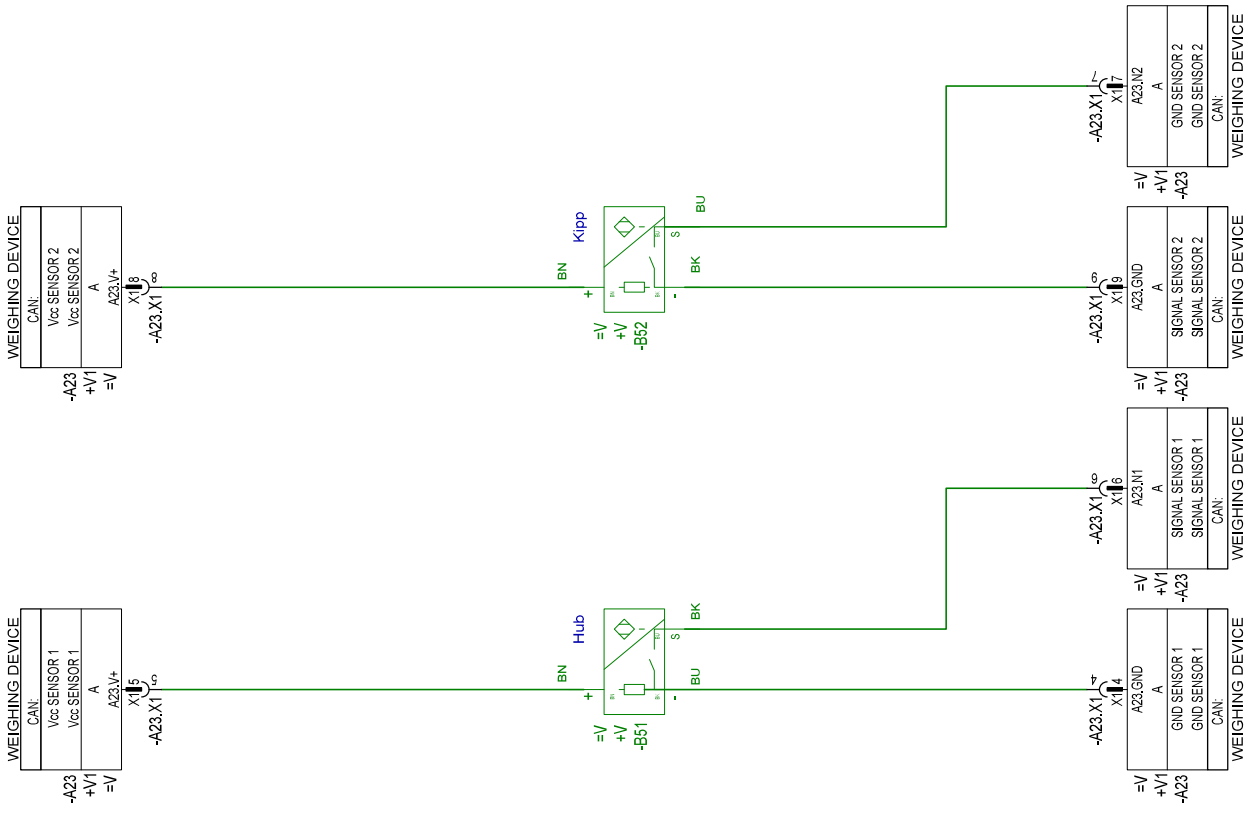

WEIGHING DEVICE	
CAN:	
-A23	Vcc SENSOR 2
+V1	Vcc SENSOR 2
=V	A
	A23.V+
	X118
	-A23.X1

WEIGHING DEVICE	
CAN:	
-A23	Vcc SENSOR 1
+V1	Vcc SENSOR 1
=V	A
	A23.V+
	X114
	-A23.X1

=V	A23.GND
+V	A
-A23	SIGNAL SENSOR 2
	SIGNAL SENSOR 2
	CAN:
	X119

=V	A23.GND
+V	A
-A23	SIGNAL SENSOR 1
	SIGNAL SENSOR 1
	CAN:
	X116

=V	A23.GND
+V	A
-A23	SIGNAL SENSOR 1
	SIGNAL SENSOR 1
	CAN:
	X117

=V	A23.GND
+V	A
-A23	SIGNAL SENSOR 2
	SIGNAL SENSOR 2
	CAN:
	X118

=V	A23.GND
+V	A
-A23	SIGNAL SENSOR 1
	SIGNAL SENSOR 1
	CAN:
	X114

=V	A23.GND
+V	A
-A23	SIGNAL SENSOR 2
	SIGNAL SENSOR 2
	CAN:
	X119

=V	A23.GND
+V	A
-A23	SIGNAL SENSOR 1
	SIGNAL SENSOR 1
	CAN:
	X116

=V	A23.GND
+V	A
-A23	SIGNAL SENSOR 2
	SIGNAL SENSOR 2
	CAN:
	X118

MACHINE TYPE
LIDOS UNIT

SERIAL NUMBER
XXXXX

LIEBHERR
FACTORY LBH

OPTION WEIGHING DEVICE LIEBHERR
E PLAN

PAGE 112 OF
CREATION DATE 26.04.2019 10:08

12418288
ITEM CODE
105
DRAWING INDEX

1333 90100 01 00
DRAWING NUMBER

Stufe 4 GG_23.11.18 E_Hauptschalter
PROJECT

Violations require compensation. All rights reserved in the case of patent, utility, model or design registration.
ISO 15015: The reproduction, distribution and utilization of this document as well as the communication of its contents to others without express authorization is prohibited.

MACHINE TYPE
LIDOS UNIT

SERIAL NUMBER
XXXXX

LIEBHERR
FACTORY LBH

OPTION Vcc ADDITIONAL MODULE OUTPUT 2
E PLAN

PAGE 122 OF
CREATION DATE 26.04.2019 10:08

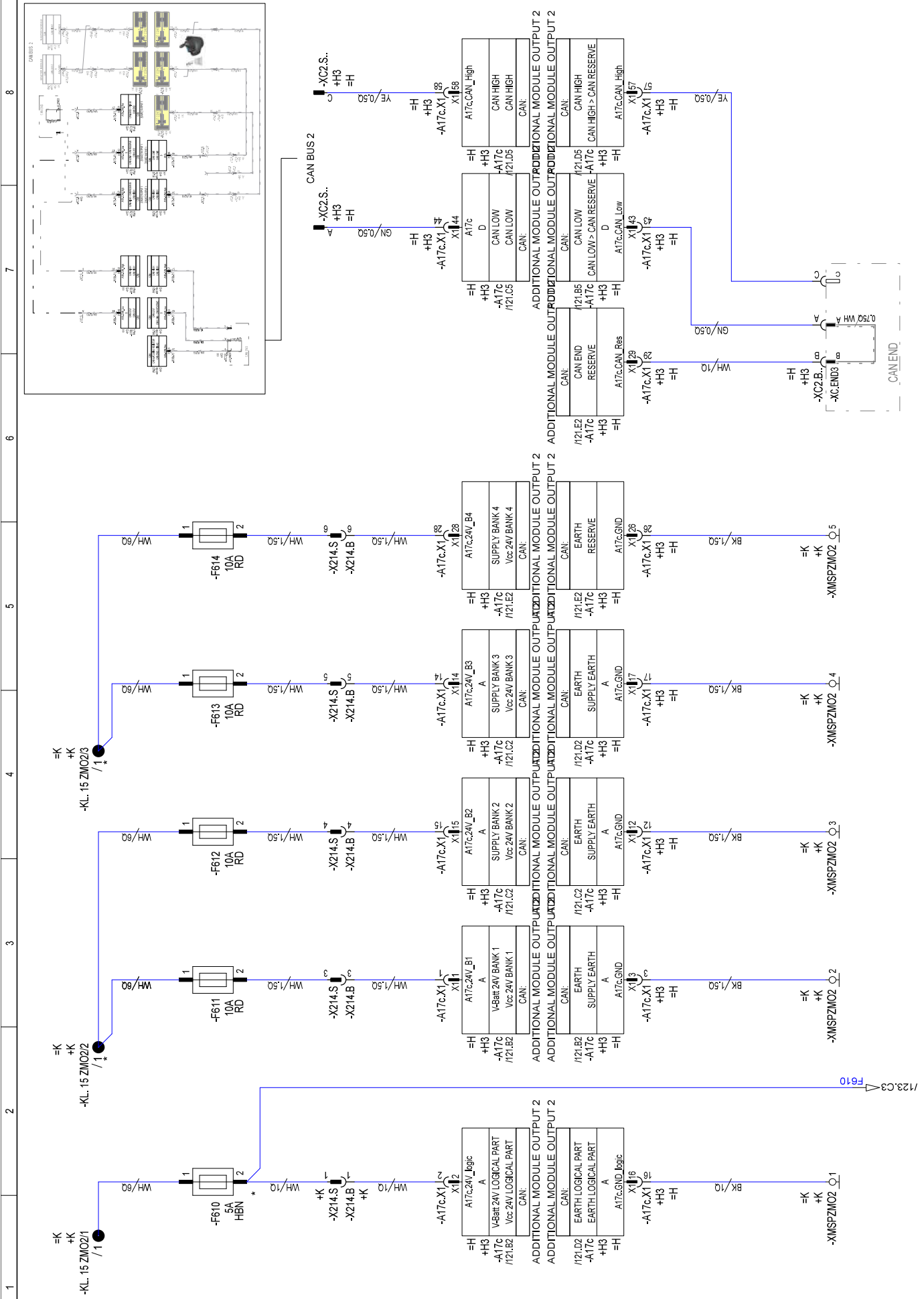

PROJECT: **Stufe 4 GG_23.11.18 E_Hauptschalter**
 DRAWING NUMBER: **1333 9010 01 00**
 DRAWING INDEX: **105**
 ITEM CODE: **12418288**

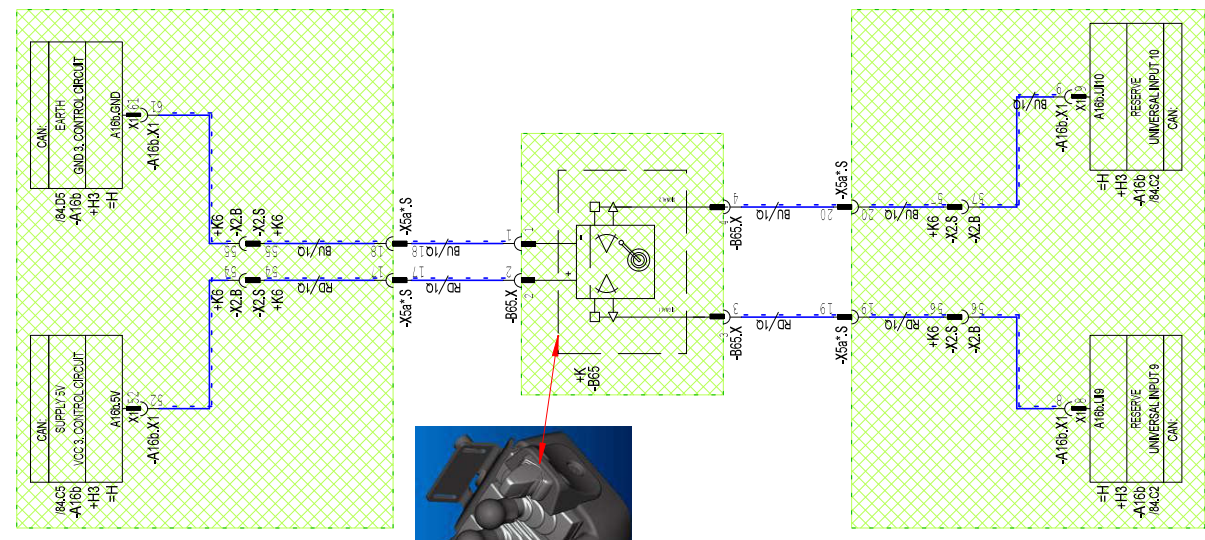
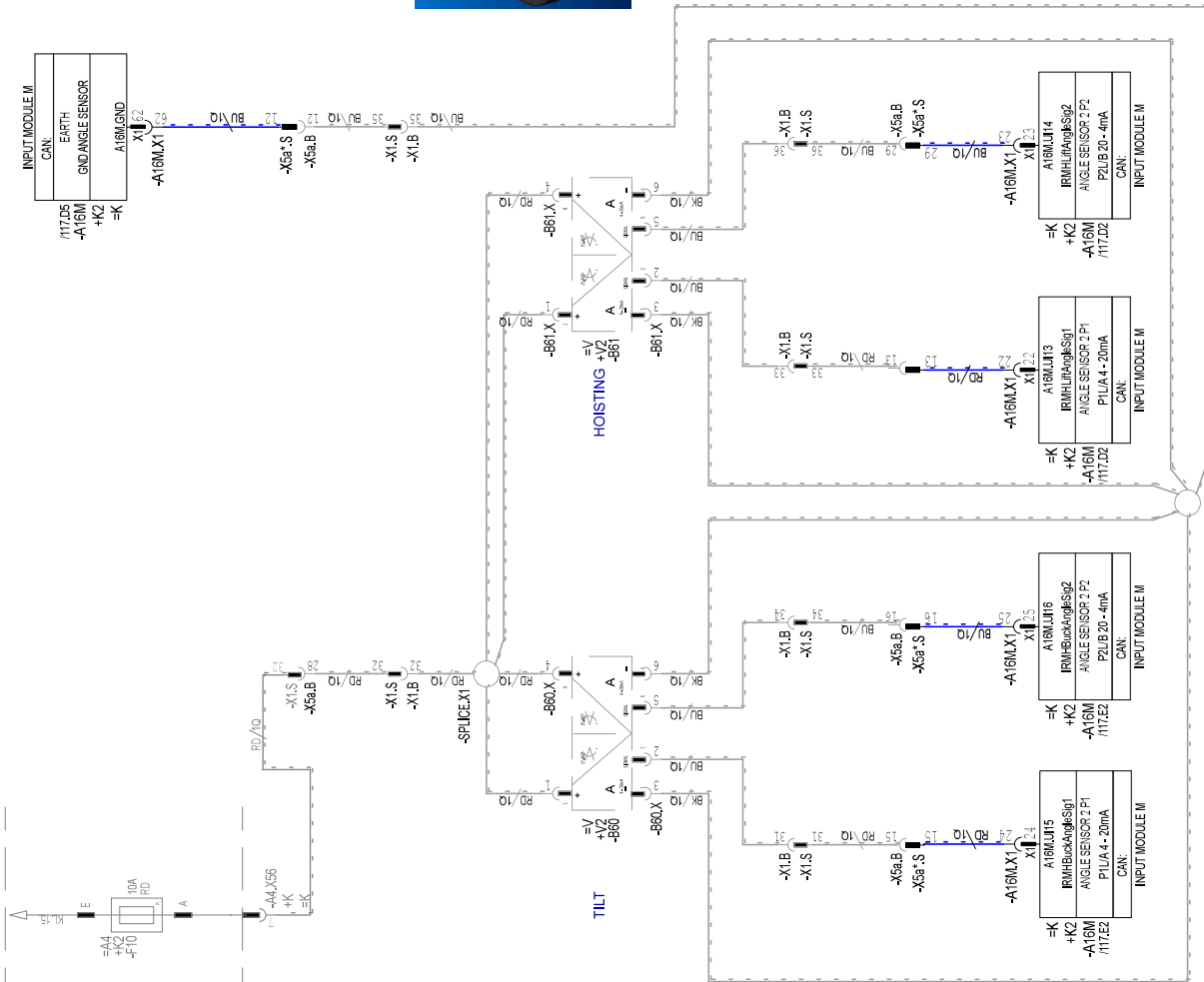
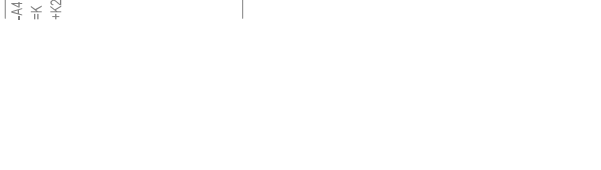

TO SERIAL NUMBER.....

MACHINE TYPE	SERIAL NUMBER	VERSION 1 MULTI-LEVER CONTROL 4. CONTROL CIRCUIT; E PLAN	PAGE 132 OF
LIDOS UNIT	XXXXX		CREATION DATE 26.04.2019 10:08

12418288 105

Item CODE DRAWING INDEX

PROJECT

Stufe 4 GG_23.11.18 E_Hauptschalter
 1333 90100 01 00
 DRAWING NUMBER

Violations require compensation. All rights reserved in the case of patent, utility model or design registration.
 The reproduction, distribution and utilization of this document or its contents to others without express authorization is prohibited.

MACHINE TYPE
LIDOS UNIT

SERIAL NUMBER
XXXXX

LIEBHERR
 FACTORY LBH

VERSION 2 LOG HANDLER IGNITION LOCK
 E PLAN

PAGE 142 OF
 CREATION DATE 26.04.2019 10:08

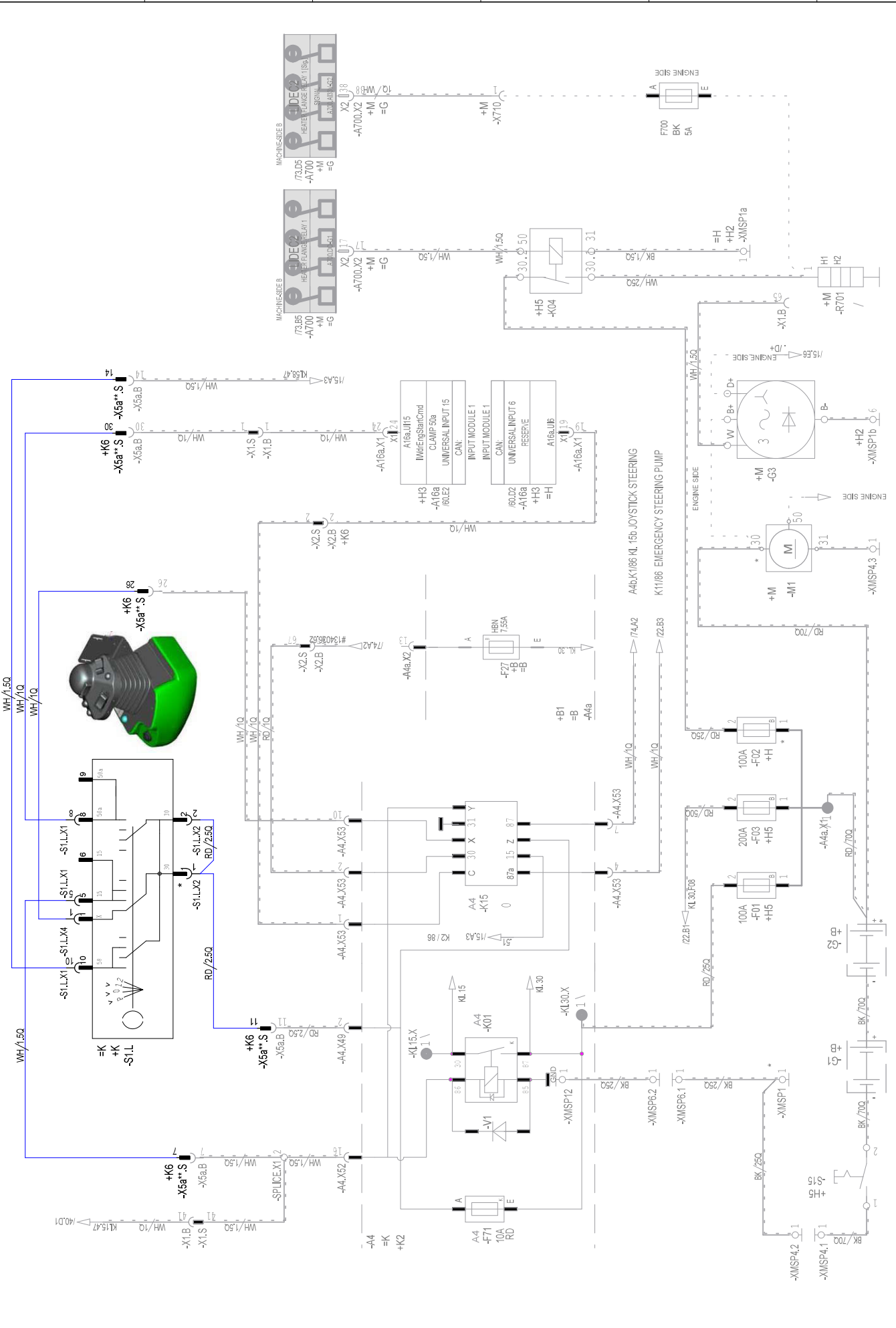

1 2 3 4 5 6 7 8

ELECTRICAL WIRING DIAGRAM

10139857

ENGINE

D936 A7-04

ENGINE ELECTRICS

10139858

SPS 10139856

MOTOR_SPL
TYPE

PROJECT: 10139858

ISO 15026. The reproduction, distribution and utilisation of this document as well as the communication of its contents to others without express authorization is prohibited. Offenders will be held liable for the payment of damages. All rights reserved in the event of the grant of a patent, utility model or design.

REPLACEMENT FOR	MARKED	Imbovs0
0	DATE	25.07.2016 12:14
CONFIDENTIAL	CHECKED	Imbbua0
	TECHNICAL REFEREE	

LIEBHERR
FACTORY LMB
A3

DESIGNATION
ELECTRICAL WIRING DIAGRAM

DESCRIPTION
ELECTRICAL WIRING DIAGRAM

ARTICLE CODE	SYSTEM	LOCATION
10139857	=M	+M
DRAWING NUMBER	SHEET 1	FROM 19
96 002 9307 90	003	

1 2 3 4 5 6 7 8

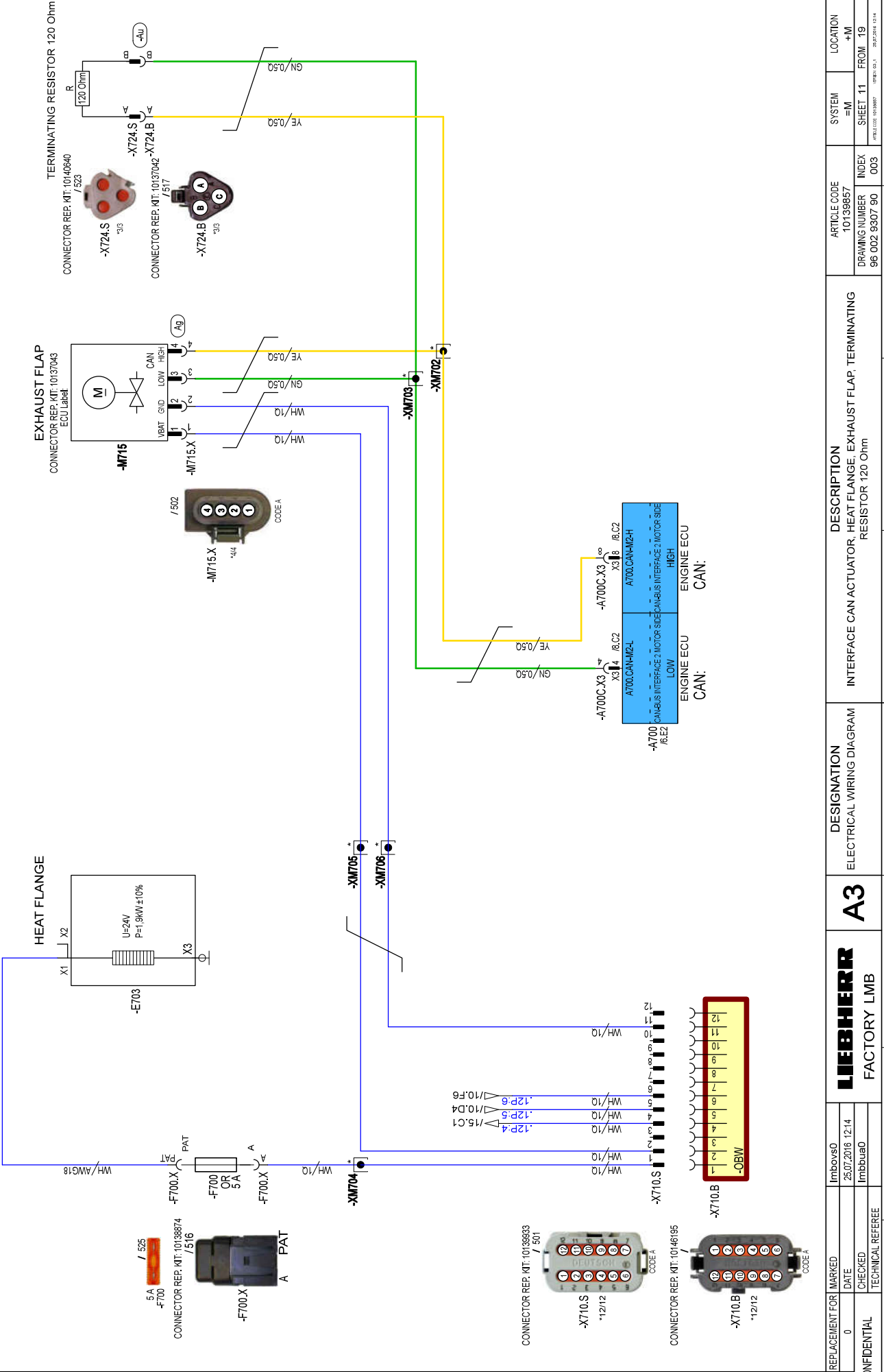

BMK	Component	CAN line	CAN address
A9	Immobiliser (option)	3	107
A11	Control unit	3	97
A15	Central control unit (Master4)		
A16a	Input module	1	45 (53, 81)
A16b	Input module (option)	2	47 (55, 83)
A17a	Output module	1	22 (14, 6, 50)
A17b	Output module (option)	2	21 (13, 5, 19)
A21	Heater/AC electronics	3	106
A23	Weighing module (option)	1	108
A25	Transmission control unit	4	J1939
A26	Control lever	2	65, 66
A29	Joystick module (option)	2 and 3	67, 68, 63, 64
A700	Engine control unit	1	92, 93, 94, 95
CAN 1	CAN line 1	1	
CAN 2	CAN line 2	2	
CAN 3	CAN line 3	3	
CAN 4	CAN line 4	4	
X60a	Diesel engine diagnostic plug	1	
X60d	Transmission diagnostic plug	4	

Tab. 304: Components

The input and output modules are mounted on the left under the cab access.

The engine control unit **A700** is mounted on the diesel engine.

The weighing module **A23** is located in the front section of the machine.

The immobiliser **A9** is fitted to the starting switch.

The central control unit (Master4) **A15** is mounted behind the rear wall cover.

The heater/AC controller **A21** is located in the heating and air conditioning unit.

The control unit **A11** is mounted on the control panel.

The control lever **A26** is mounted to the right of the operator's seat.

The joystick module **A29** is installed under the operator's seat.

The diesel engine diagnostic plug **X60a** is installed on the diesel engine.

The transmission diagnostic plug **X60d** is installed on the transmission.

2 Function

The machine is electronically controlled by the central control unit (Master4) **A15**.

The central control unit is connected via the CAN lines to the CAN devices. All CAN devices on a CAN line are connected in series.

At the end of each CAN line there is a 120 Ω resistor. That resistor is normally integrated in the CAN devices and can be activated by plugging in an electrical connector (jumper).

- Resistances can be measured to an accuracy of $\pm 0.5\%$.
- Resistance measurement is designed for sensor types PT1000 and Ni1000.

Frequency inputs:

- The module has 2 inputs for frequency measurement (10-70 kHz).

2.3 Input module addresses

Module	Address	Function
Input module	IA16	Analogue universal measurement inputs
	IF02	Frequency measurement inputs
	IR02	Resistance measurement inputs

Tab. 310: Input module addresses

The CAN modules are addressed using the Sculi diagnostic software.

110.5.3.3 Output modules

Valid for: L580-1464;

(For more information see: 020.8.3 Output module, page 020-33)

1 Layout

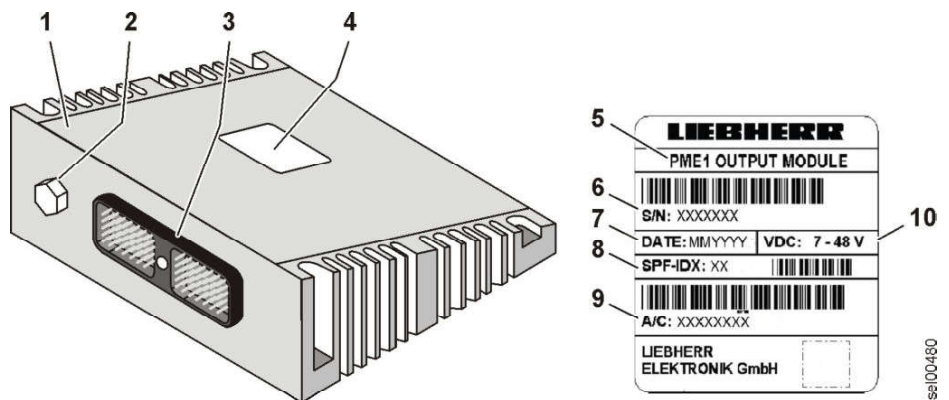

Fig. 558: Output module with type plate

- | | | | |
|----------|------------------------------------|-----------|---------------------|
| 1 | Housing made of die-cast aluminium | 6 | Serial number |
| 2 | Goretex membrane | 7 | Date of manufacture |
| 3 | Connector | 8 | Specification index |
| 4 | Type plate | 9 | Article code |
| 5 | Device designation | 10 | Voltage range |

Output modules consist of various electronic components, fitted in a die-cast aluminium housing. Depending on the device type, up to 4 output modules can be installed.

LBH/11835201/20/21+20191218_101659/en

110.6.4 Door contact switch (inductive sensor)

Valid for: L580-1464/46489-;

1 Layout

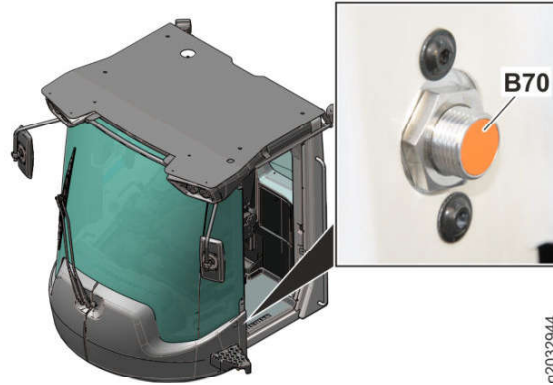

Fig. 567: Door contact switch

The door contact switch **B70** is installed in the door frame.

2 Function

The door contact switch **B70** activates the interior lighting E2 via the relay K8a and relay K8.

The door contact switch **B70** is an inductive sensor.

Condition for activating the interior lighting E2 via the door contact switch **B70**:

- Cab door is open.
- Turn ignition on.
- Switch for the interior lighting E2 is in “Activate via door contact switch” position.

The air conditioning control unit A21 reads the signal from the door contact switch **B70**. With manual air conditioning, the signal from the door contact switch does not affect the air conditioning.

With automatic air conditioning, the air conditioning control unit reduces the fan speed to a minimum when the cab door is open.

120 Gearbox

Contents

120.1	Overview of transmission <i>L580-1464;</i>	120-2
120.2	Transmission hydraulics	120-16
120.2.1	Overview of transmission hydraulics <i>L580-1464;</i>	120-16
120.2.2	Gear pump <i>L580-1464;</i>	120-20
120.2.3	Transmission control valve block <i>L580-1464;</i>	120-21
120.2.4	Hydrostat module <i>L580-1464;</i>	120-24
120.3	Transmission electronics	120-29
120.3.1	Overview of the electrical control system of the transmission <i>L580-1464;</i>	120-29
120.3.2	Filter bypass switch <i>L580-1464;</i>	120-30
120.3.3	Gear shifting proportional solenoid <i>L580-1464;</i>	120-31
120.3.4	Pressure sensor for hydrostat <i>L580-1464;</i>	120-32
120.3.5	Engine speed sensor <i>L580-1464;</i>	120-33
120.3.6	Temperature sensor <i>L580-1464;</i>	120-34
120.3.7	Proportional solenoid for position control <i>L580-1464;</i>	120-34

Name	Description	Name	Description	Name	Description
W2	Shaft 2	Z7	Gearwheel 7		
ZS1	Sun gear 1	Z8	Gearwheel 8		

Tab. 329: Key

To start the machine moving, the double yoke drive both rotary groups simultaneously. The pump T1 swivels out, while the motor T2 swivels in.

As a result, the pump T1 delivers oil through the duct A to drive the motor T2. Because the pump T1 is only at a small angle and the motor T2 is almost at the maximum angle, a very high output torque is transmitted to the closed clutch K1. The machine moves purely under hydraulic power with maximum tractive force.

As soon as the machine starts moving, the ring gear ZH also starts turning. The ring gear ZH turns in the same direction as the gearwheel Z5. This reduces the speed transmitted to the sun gear ZS1 and thus also the speed of the pump T1 in relation to the engine speed. Some of the power is then transferred mechanically via the ring gear ZH and the two gearwheels Z6 and Z9 to the clutch K1.

2.3.3 Machine moving and accelerating (clutch K1 closed)

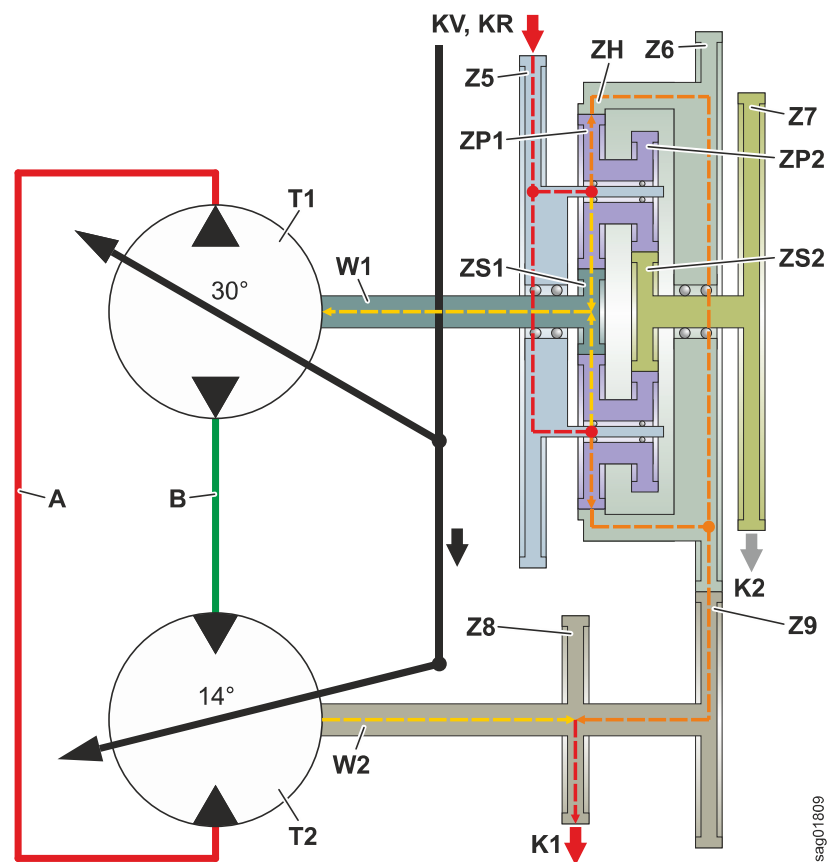

Fig. 581: Machine moving and accelerating (clutch K1 closed)

Name	Description	Name	Description	Name	Description
A	Duct A	ZS2	Sun gear 2	Z9	Gearwheel 9

LBH/11835201/20/21+20191218_101659/en

sag01809

120.2.3 Transmission control valve block

Valid for: L580-1464;

1 Layout

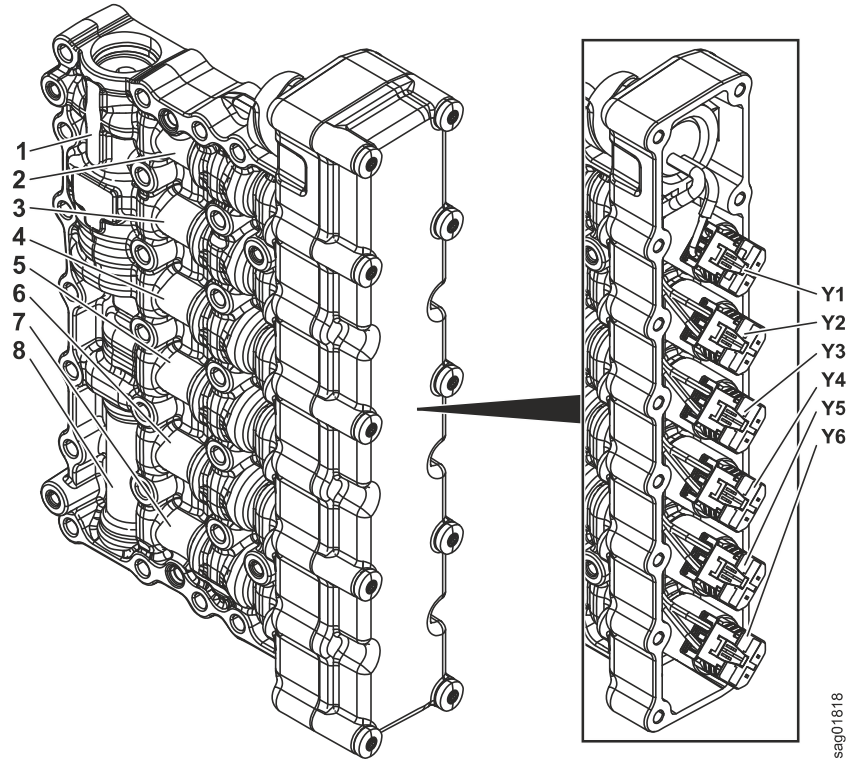

Fig. 587: Transmission control valve block (from front left)

- | | | | |
|---|--|---|--|
| 1 | Main pressure valve 20 bar | 5 | Secondary spool for reverse travel direction clutch (KR) |
| 2 | Secondary spool for clutch 2 (K2) | 6 | Secondary spool for clutch 1 (K1) |
| 3 | Secondary spool for forward travel direction clutch (KV) | 7 | Secondary spool valve for 2nd optional connection |
| 4 | Secondary spool valve for 1st optional connection | 8 | Pressure reducing valve 9 bar |

BMK	Function	BMK	Function	BMK	Function
Y1	Proportional solenoid for clutch 2 (K2)	Y3	Proportional solenoid for 1st optional connection	Y5	Proportional solenoid for clutch 1 (K1)
Y2	Proportional solenoid for forward travel direction clutch (KV)	Y4	Proportional solenoid for reverse travel direction clutch (KR)	Y6	Proportional solenoid for 2nd optional connection

Tab. 335: Equipment codes

Transmission control valve block is bolted to front of transmission.

LBH/11835201/20/21+20191218_101659/en

If the filter is heavily contaminated, the filter bypass valve opens and the switching mechanism 1 is released. That opens the switch contacts. A line break is measured at the filter bypass valve.

120.3.3 Gear shifting proportional solenoid

Valid for: L580-1464;

1.1 Layout

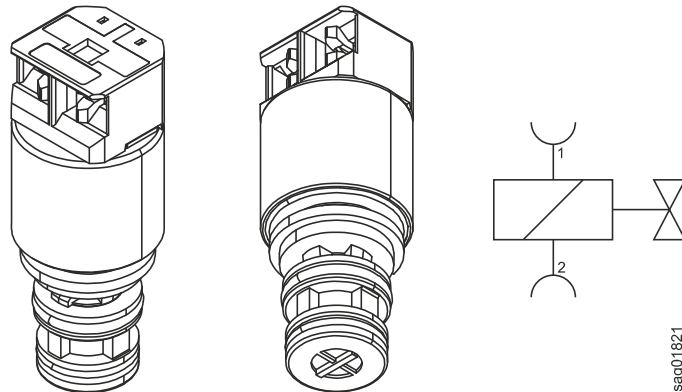

Fig. 595: Gear shifting proportional solenoid

BMK	Function
Y1	Proportional solenoid for clutch 2 (K2)
Y2	Proportional solenoid for forward travel direction clutch (KV)
Y3	Proportional solenoid for 1st optional connection
Y4	Proportional solenoid for reverse travel direction clutch (KR)
Y5	Proportional solenoid for clutch 1 (K1)
Y6	Proportional solenoid for 2nd optional connection

Tab. 344: Equipment codes

The gear shift proportional control solenoids are fitted in the valve block.

2.1 Function

The gear shift proportional control solenoids are used to operate the clutches.

2.2 Self-locking differential

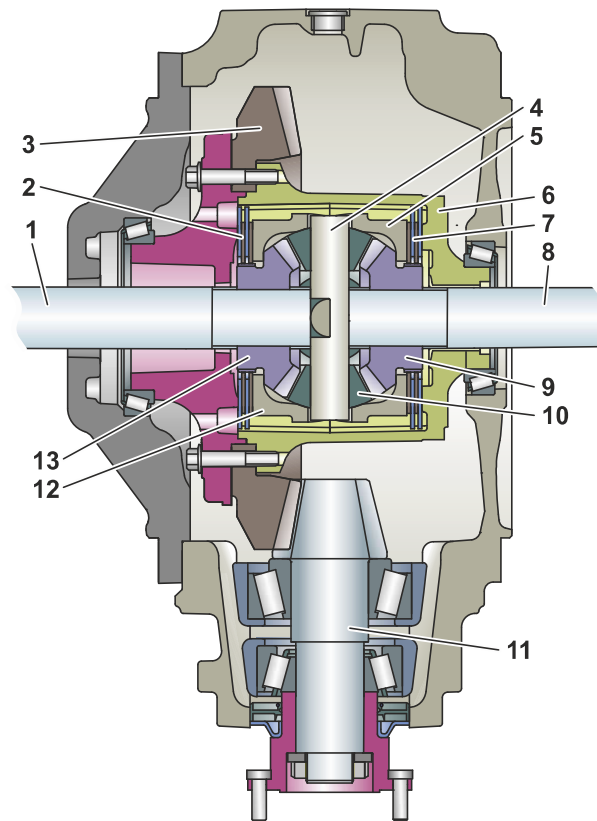

Fig. 604: Self-locking differential

- | | | | |
|---|-------------------------------|----|---------------------------------|
| 1 | Left half shaft | 8 | Right half shaft |
| 2 | Locking discs for left wheel | 9 | Tight axle tapered gear |
| 3 | Crown wheel | 10 | Compensation tapered gear |
| 4 | Compensation axle | 11 | Axle input shaft (tapered gear) |
| 5 | Right thrust ring | 12 | Left thrust ring |
| 6 | Differential housing | 13 | Left axle tapered gear |
| 7 | Locking discs for right wheel | | |

2.2.1 Speed balance

When cornering, the wheel on the inside of the bend covers less distance than the wheel on the outside. This means that the inside wheel turns at a lower speed than the outer wheel.

The axle input shaft **11** drives the crown wheel **3**. This is rigidly connected to the differential housing **6**. Along with the differential housing **6**, two compensation axles **4** and therefore four compensation tapered gears **10** rotate around the half shafts **1** and **8**. The axle tapered gears **9** and **13** are driven by the compensation tapered gears **10**.

The compensation tapered gears **10** do not turn as long as the wheels are turning at the same speed.

If one wheel turns faster than the other, this is compensated by the compensation tapered gears **10** rotating around the compensation axles **4**. The half shaft of the inside wheel turns slower and the half shaft of the outside wheel turns faster than the crown wheel **3** by the same amount. The speed of the axle input shaft **11** remains the same.

The radial seals **8** protect the bearings from dirt.

140.1.2 Articulation lock

Valid for: L580-1464;

1 Layout

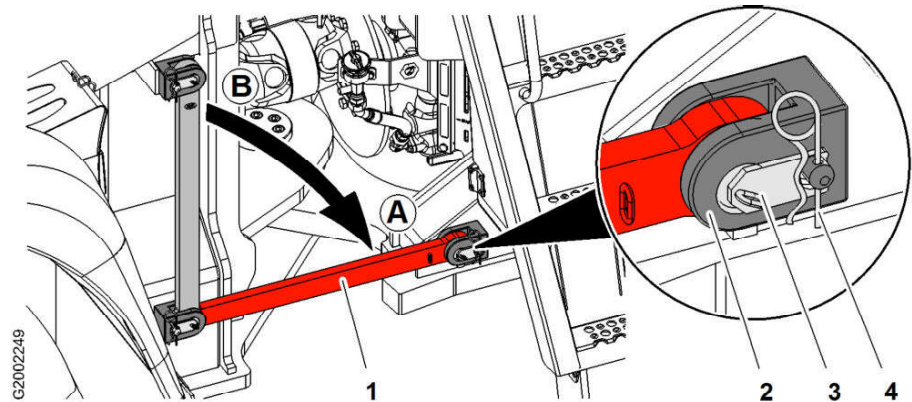

Fig. 611: Engaging the articulation lock

- | | | | |
|---|-------------|---|-----------|
| 1 | Locking bar | 3 | Pin |
| 2 | Bracket | 4 | Split pin |

The articulation bearing is fitted between the front and rear sections.

2 Function

The articulation lock creates a rigid connection between the front and rear sections. Steering is no longer possible.

This means the steering is blocked, for example, when transporting the machine or for maintenance.

150.3.2 Quick coupler hydraulics

150.3.2.1 Overview of the quick coupler hydraulics

Valid for: L580-1464/0-45466;

1 Layout

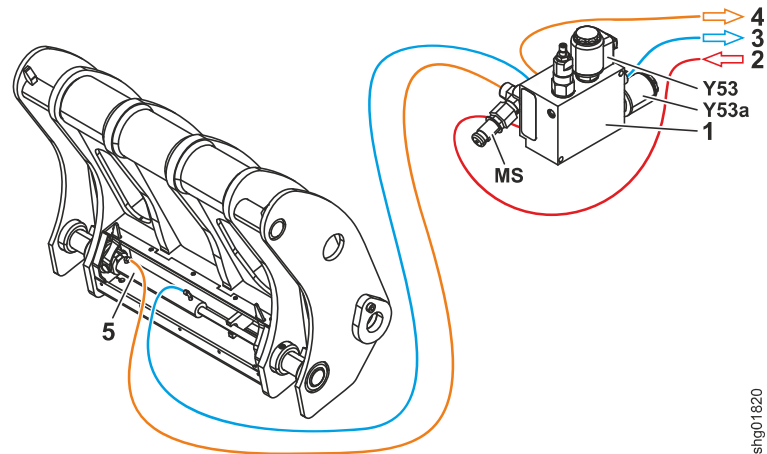

Fig. 618: Overview of the quick coupler hydraulics (from front left)

- | | | | |
|---|--|---|--|
| 1 | Valve block for quick coupler | 4 | Load sensing signal for working pump (via control valve block) |
| 2 | Oil supply from working pump (via control valve block) | 5 | Hydraulic cylinder for locking quick coupler |
| 3 | Return flow to control valve block | | |

Name	Test point
MS	Quick coupler closing pressure

Tab. 356: Test points

BMK	Function	BMK	Function
Y53	Solenoid for opening quick coupler	Y53a	Quick coupler load sensing signal solenoid

Tab. 357: Equipment codes

The quick coupler hydraulics consist of the following components:

- Valve block for quick coupler (For more information see: [Valve block for quick coupler, page 150-13](#))
- Hydraulic cylinder for locking quick coupler

LBH/11835201/20/21+20191218_101659/en

The quick coupler load sensing signal solenoid valve **Y53a** generates a load sensing signal. The load sensing signal causes the working hydraulics pump to swing out. This provides sufficient pressure for the hydraulic cylinder to retract.

The quick coupler unlocking relay **Y53** supplies voltage to the quick coupler solenoid valve **K231**. This directs hydraulic oil to the ring side of the hydraulic cylinder. The hydraulic cylinder retracts. At the same time, a signal is sent via the input module **A16a** to the central control unit. This signal causes the central control unit to activate the warning tone.

The latching function relay **K232** ensures that the quick coupler solenoid valve **Y53** and the signal to the central control unit remain active even when the *quick coupler* button **S23** is released.

The quick coupler load sensing signal solenoid valve **Y53a** is only active when the *quick coupler* **S23** button is actuated.

1.3 Locking the quick coupler

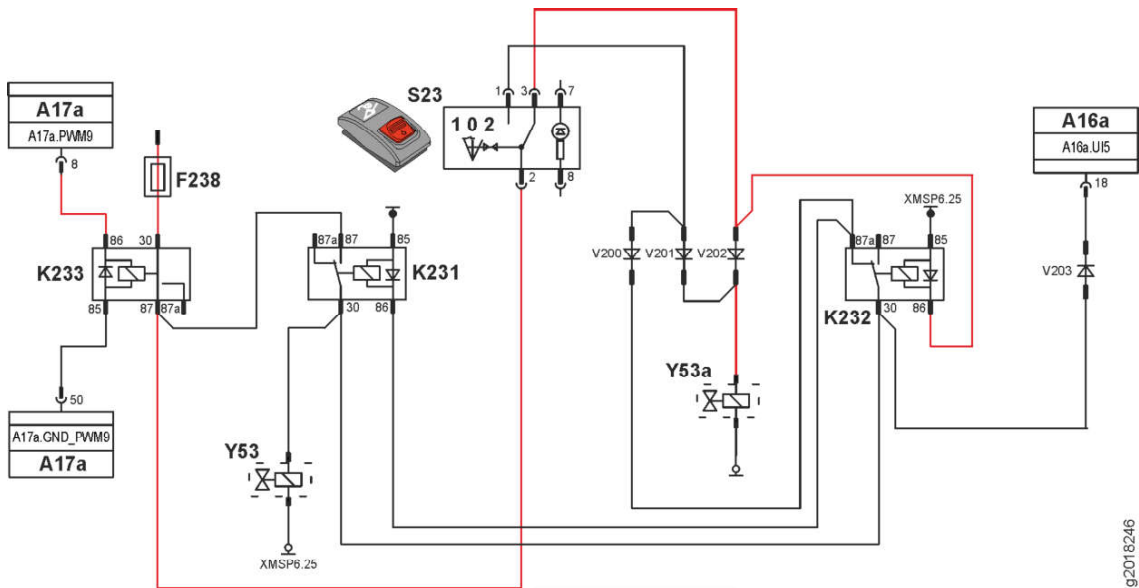

Fig. 628: Button S23 in quick coupler locking position

Position	Description	Position	Description
A16a	Input module A16a	K233	Safety shutdown relay
A17a	Output module A17a	S23	Quick coupler button
F238	Quick coupler fuse	Y53	Quick coupler solenoid valve
K231	Quick coupler opening relay	Y53a	Quick coupler load sensing signal solenoid valve
K232	Latching function relay		

Tab. 374: Items

When the *quick coupler* button **S23** is in position **2**, the quick coupler is locked.

The *quick coupler* **S23** button supplies the latching function relay **K232** and the quick coupler load sensing signal solenoid valve **Y53a** with voltage.

LBH11835201/20/21+20191218_101659/en

The buttons for additional functions are located on the side of the control lever.

2 Function

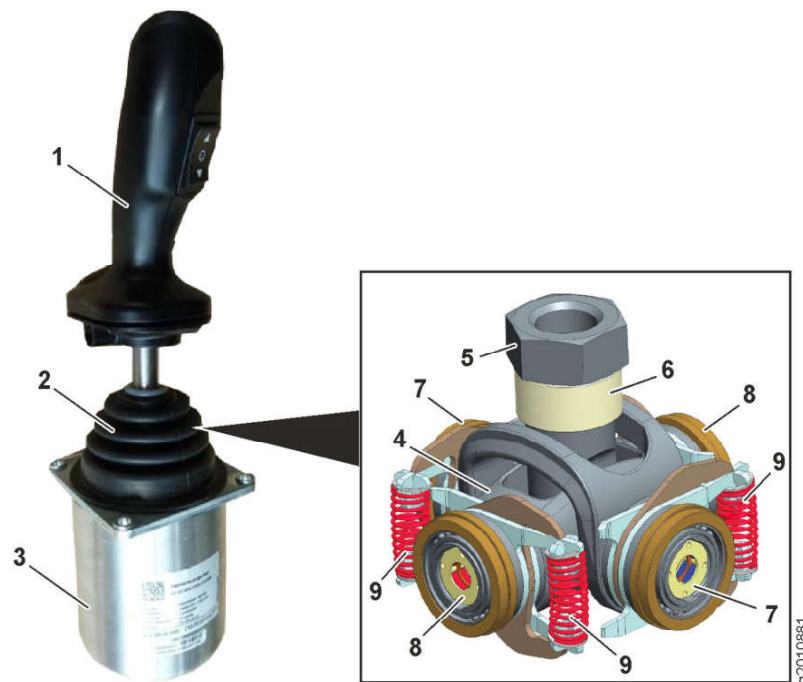

Fig. 634: Function of the control lever

- | | | | |
|---|----------------------------------|---|---|
| 1 | Control lever handle | 6 | Stop socket |
| 2 | Universal joint | 7 | Angle sensor for the tilt function |
| 3 | CAN module for control lever A26 | 8 | Angle sensor for the lifting and lowering functions |
| 4 | Universal joint | 9 | Return springs |
| 5 | Handle holder | | |

The control lever consists of the handle **1**, the universal joint **4** and the CAN module **3**.

The handle of the control lever contains the travel direction switch and the buttons for additional functions.

The signals from the travel direction switch and the additional function buttons are read by the CAN module of the control lever.

The handle of the control lever is screwed onto the universal joint.

The angle sensors for the tilt function **7** and the angle sensors for the lifting and lowering functions **8** are attached to the axles of the universal joint. These sensors measure the inclination of the control lever.

The universal joint has an action point in all four directions (additional spring force). If this action point is exceeded for more than 0.3 seconds, the kick-out function in that direction is activated.

The control lever CAN module reads and evaluates the signals from the angle sensors, the travel direction switch and the buttons.

This data is sent via a CAN line to the central control unit.

The control lever does not need to be calibrated.

1	Outside temperature sensor B39	12	Cooling/heating mixer flap
2	Blower	13	Mixer plate
3	Anti-icing sensor B38	14	Outlet temperature sensor B41
4	Evaporator	15	Outlet hood
5	Refrigerant forward flow	16	Servo motor for head/front level M17
6	Condensate trap	17	Cable harness outlet
7	Expansion valve	18	Servo motor for mixer flap M18
8	Refrigerant return flow	19	Air conditioning controller A21
9	Heat exchanger	20	Inside temperature sensor B40
10	Coolant forward flow	21	Servo motor for recirculated air/fresh air flap M14
11	Coolant return flow		

The heating and air conditioning unit is installed on the right on the operator's cab.

2.1 Function

The outside temperature sensor **1** measures the temperature of the fresh air drawn in from outside.

The anti-icing sensor **3** measures the temperature on the evaporator. The evaporator temperature is measured to prevent the evaporator from icing up. If the temperature falls below $-1\text{ }^{\circ}\text{C}$, the compressor coupling is switched off.

The outlet temperature sensor **14** measures the temperature in the mixing chamber. The temperature in the mixing chamber corresponds to the outlet temperature into the operator's cab.

The blower **2** draws in fresh air from outside. The fresh air drawn in is pumped through the condenser and if necessary the heat exchanger via the air pipes into the operator's cab.

The accumulated condensate is collected in the trap **6**. The collected condensate is then discharged via a hose on the bottom of the heating and air conditioning unit.

Refrigerant is evaporated in evaporator **4**. This extracts heat from the surroundings and the evaporator is cooled.

The expansion valve **7** injects refrigerant into the evaporator.

Hot coolant from the diesel engine passes through the heat exchanger **9**. This warms up the heat exchanger. If air is passed through the heat exchanger, it is heated up. The hot air is directed into the operator's cab. This heats the operator's cab.

The cooling/heating mixer flap **12** regulates cooling and heating. In heating mode, the air passes through the heat exchanger. In cooling mode, the path through the heat exchanger is shut off. The air passes directly from the evaporator to the mixing chamber.

The servo motor for the head/front-level flap **16** controls the distribution of air between the head area and the front area.

The servo motor for the mixer flap **18** controls the position of the flap to switch between heating and cooling.

The air conditioning controller **19** processes data from the sensors and controls the servo motors.

The cab air temperature sensor **20** measures the temperature in the operator's cab.

The servo motor for the fresh air flap **21** controls the amount of fresh air in the air drawn in.

CLICK HERE TO **DOWNLOAD** THE COMPLETE MANUAL

- Thank you very much for reading the preview of the manual.
- You can download the complete manual from: www.heydownloads.com by clicking the link below



- Please note: If there is no response to **CLICKING** the link, please download this PDF first and then click on it.

CLICK HERE TO **DOWNLOAD** THE COMPLETE MANUAL