

**en**

**Service manual**

Wheel loader

**Document ID**

**Order number:** 12204898  
**Issued:** 08-2019  
**Version:** 11  
**Author:** LBH / Technical Documentation Department

**Product ID**

**Manufacturer:** Liebherr-Werk Bischofshofen GmbH  
**Valid for:** L 538-1559

**Conformity:**



**Contact**

Liebherr-Werk Bischofshofen GmbH  
Dr. Hans Liebherr-Straße 4  
A – 5500 Bischofshofen

CLICK HERE TO **DOWNLOAD** THE COMPLETE MANUAL

- Thank you very much for reading the preview of the manual.
- You can download the complete manual from: [www.heydownloads.com](http://www.heydownloads.com) by clicking the link below



- Please note: If there is no response to CLICKING the link, please download this PDF first and then click on it.

CLICK HERE TO **DOWNLOAD** THE COMPLETE MANUAL

	020.14.2.4	MX-F 75	020-42
	020.14.2.5	MX-F105	020-42
<b>030</b>	<b>Maintenance</b>		<b>030-1</b>
030.1	Maintenance and inspection schedule		030-10
030.2	Filling quantities and lubrication chart		030-15
030.2.1	Recommended lubricants <i>L538-1559;</i>		030-15
030.2.2	Recommended operating fluids <i>L538-1559;</i>		030-16
030.3	Lubricants and fuels		030-17
030.3.1	General information on lubricants and fuels		030-17
	030.3.1.1	General questions	030-17
	030.3.1.2	Safety data sheets	030-17
	030.3.1.3	Technical data sheets	030-17
	030.3.1.4	Specific Liebherr standards	030-17
030.3.2	General information on changing lubricants and fuels		030-17
030.3.3	Converting hydraulic system from mineral oils to biodegradable hydraulic fluids		030-18
030.3.4	Diesel fuels <i>L538-1559;</i>		030-18
	030.3.4.1	Minimum quality requirement	030-18
	030.3.4.2	Minimum quality requirement	030-18
030.3.5	Diesel exhaust fluid <i>L538-1559;</i>		030-19
	030.3.5.1	Liebherr recommendation	030-19
	030.3.5.2	Minimum quality requirement	030-19
030.3.6	Engine oils <i>L538-1559;</i>		030-19
	030.3.6.1	Liebherr recommendation	030-19
	030.3.6.3	Minimum quality requirement	030-19
030.3.7	Refrigerant <i>L538-1559;</i>		030-20
030.3.8	Coolant <i>L538-1559;</i>		030-20
	030.3.8.1	Requirements for the water used	030-20
	030.3.8.2	Antifreeze and corrosion inhibitor	030-20
	030.3.8.3	Minimum quality requirement	030-21

050.3.1	General overview of electronic control system <i>L538-1559;</i>	050-12
050.3.2	Temperature sensor for coolant <i>L538-1559;</i>	050-15
050.3.3	Hydraulic oil temperature sensor <i>L538-1559;</i>	050-17
050.3.4	Temperature sensor for charge air <i>L538-1559;</i>	050-18
050.4	Cooler	050-20
050.4.1	Cooler unit <i>L538-1559;</i>	050-20
050.5	Reversible fan drive	050-21
050.5.1	Overview of the reversible fan drive <i>L538-1559;</i>	050-21
050.5.2	Fan reversal valve block <i>L538-1559;</i>	050-23
<b>060</b>	<b>Working hydraulics</b>	<b>060-1</b>
060.1	Overview of Z-bar kinematics working hydraulics <i>L538-1559;</i>	060-2
060.2	Overview of the P kinematics working hydraulics <i>L538-1559;</i>	060-10
060.3	Working pump <i>L538-1559;</i>	060-14
060.4	Control valve block for Z-bar kinematics <i>L538-1559;</i>	060-22
060.5	Control block for P kinematics <i>L538-1559;</i>	060-31
060.6	Pilot control	060-37
060.6.1	Servo pressure solenoid valve <i>L538-1559;</i>	060-37
060.7	Ride control	060-39
060.7.1	Overview of ride control system <i>L538-1559;</i>	060-39
060.7.2	Stabilisation module <i>L538-1559;</i>	060-42
060.8	Electronics of the working hydraulics	060-45
060.8.1	Overview of electrical controls the working hydraulics <i>L538-1559;</i>	060-45
060.8.2	Working hydraulics angle sensors <i>L538-1559;</i>	060-48
060.9	Pipe break protection	060-51

010.4	Preservation guidelines	010-45
010.4.1	General information	010-45
010.4.2	Machine out of service for an unknown period of time	010-45
010.4.3	Putting the machine out of service	010-46
010.4.3.1	Out of service for up to 2 months	010-46
010.4.3.2	Out of service for up to 12 months	010-47
010.4.3.3	Out of service for longer than 12 months	010-48
010.4.4	Putting back into service	010-48
010.4.4.1	After being out of service for 2 months	010-48
010.4.4.2	After being out of service for 12 months	010-49
010.4.4.3	After being out of service for longer than 12 months	010-49

### 010.1.4.2 Roll over protective structure (ROPS)

#### Danger to life

##### Damaged falling object protective structures

- Do not put machine into service with damaged falling object protective structures.
- Do not put machine into service with deformed falling object protective structures.
- Do not use falling object protective structures with structural changes.
- Do not use repaired falling object protective structures.
- Do not perform welding on falling object protective structures.
- Do not cut or saw falling object protective structures.
- Do not drill falling object protective structures.

##### Exceeding of total weight

- Make sure that total weight of machine (see identification plate) is not exceeded.
- Make sure that the machine does not exceed the total weight with heavy working tools.
- Make sure that the machine does not exceed the total weight after changing the working attachment.
- Make sure that the machine does not exceed the total weight with add-ons or after retrofitting.

### 010.1.4.3 Falling object protective structures (FOPS)

#### Danger to life

##### Damaged falling object protective structures

- Do not put machine into service with damaged falling object protective structures.
- Do not put machine into service with deformed falling object protective structures.
- Do not use falling object protective structures with structural changes.
- Do not use repaired falling object protective structures.
- Do not perform welding on falling object protective structures.
- Do not cut or saw falling object protective structures.
- Do not drill falling object protective structures.

### 010.1.5 Emergency equipment on the machine

#### 010.1.5.1 Emergency exit (standard)



##### Danger to life

##### Incorrect labelling



- Make sure that all information signs are present.
- Make sure that all information signs are legible.

## 010.2 Special tools for maintenance and repair work

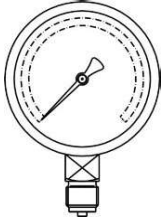
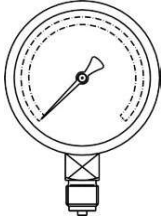
### 010.2.1 Special tools, general



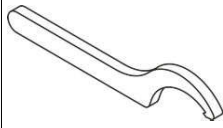

Designation	Item code	Remarks	Fig.:
Refractometer	11830573	For checking the acid density of the batteries, the antifreeze concentration and the diesel exhaust fluid	
24 volt vacuum pump	7408148	For preventing loss of oil when working on the hydraulic system	
Testing and filling device for hydro accumulators, with case	8460226	For testing and filling hydro accumulators	
Pressure gauge (40 bar), class 1.0	7361288	For testing hydraulic pressure	
Pressure gauge (250 bar), class 1.0	7361285	For testing hydraulic pressure	

LBH/12204898/11211-20190801\_073806/en

Designation	Item code	Remark	Fig.
Spanner for piston nut (hook wrench DIN 1810)	12211049	For fitting the piston nut	
Piston rod bearing assembly unit	12211044	For fitting the piston rod bearing	

Tab. 11: Special tools for steering cylinders

### 010.2.9 Special tools for the electrical system

Designation	ID number	Remark	Fig.:
Digital multimeter	10018500	For measuring voltage, current, resistance and frequency	
Test probe, red	884191214	For measurements at plug connections	
Test probe, black	884191114	For measurements at plug connections	
Solenoid tester	10028268	For testing solenoid valves	

LBH/12204898/11/21+20190801\_073806/en

Metric standard threads and fine threads				Metric standard threads and fine threads			
At least one element of the bolted joint (bolts, washers, nuts etc.) with the following surface: fIZn = zinc flake coating (LH standard 10021432, LH standard 10215295 fIZnnc-480h-L valid $\geq$ M6 )				All elements of the bolted joint (bolts, washers, nuts etc.) with the following surface: Black oxide or phosphated Galvanised (LH standard 10215295 Fe//ZnNi(12)5//Cn//T2)			
Minimum total coefficient of friction $\mu_G = 0.09$				Minimum total coefficient of friction $\mu_G = 0.11$			
Thread	Strength class	Assembly prestressing forces $F_M$ in kN	Tightening torques $M_A$ in Nm	Thread	Strength class	Assembly prestressing forces $F_M$ in kN	Tightening torques $M_A$ in Nm
M 33	8.8	370	1550	M 33	8.8	370	1800
	10.9	550	2250		10.9	540	2600
	12.9	640	2600		12.9	630	3100
M 33 x 1.5	8.8	430	1650	M 33 x 1.5	8.8	420	1950
	10.9	630	2450		10.9	620	2900
	12.9	740	2800		12.9	730	3400
M 33 x 2	8.8	420	1600	M 33 x 2	8.8	410	1900
	10.9	610	2400		10.9	600	2800
	12.9	720	2800		12.9	700	3300
M 36	8.8	440	1950	M 36	8.8	430	2300
	10.9	650	2900		10.9	630	3400
	12.9	760	3400		12.9	740	3900
M 36 x 1.5	8.8	520	2150	M 36 x 1.5	8.8	510	2600
	10.9	760	3200		10.9	750	3800
	12.9	890	3700		12.9	870	4400
M 36 x 3	8.8	470	2050	M 36 x 3	8.8	460	2400
	10.9	690	3000		10.9	680	3500
	12.9	810	3500		12.9	790	4100
M 39	8.8	530	2500	M 39	8.8	520	3000
	10.9	770	3700		10.9	760	4400
	12.9	910	4400		12.9	890	5100
M 39 x 1.5	8.8	610	2800	M 39 x 1.5	8.8	600	3300
	10.9	900	4000		10.9	880	4800
	12.9	1050	4700		12.9	1030	5600
M 39 x 3	8.8	560	2600	M 39 x 3	8.8	550	3100
	10.9	820	3900		10.9	810	4500
	12.9	960	4500		12.9	940	5300

Tab. 18: Bolt prestressing forces and tightening torques

\*The tightening torques for fIZn bolts <M10 are non-binding because no fixed friction coefficient window is defined in the LH10215295 standard. According to the

020.7.3	Steering damper hydro accumulator <i>L538-1559;</i>	020-26
020.7.4	Emergency steering pump <i>L538-1559;</i>	020-26
020.7.5	Emergency steering pressure switch B3 <i>L538-1559;</i>	020-27
020.7.6	Emergency steering check pressure switch B3a <i>L538-1559;</i>	020-27
020.7.7	Joystick steering control valve block <i>L538-1559/0-53763;</i>	020-27
020.7.8	Joystick steering control valve block <i>L538-1559/53764-;</i>	020-28
020.8	Brake system	020-29
020.8.1	Brake pump <i>L538-1559;</i>	020-29
020.8.2	Compact brake valve <i>L538-1559;</i>	020-29
020.8.3	Service brake hydro accumulator <i>L538-1559;</i>	020-29
020.8.4	Brake light pressure switch B12 <i>L538-1559;</i>	020-29
020.8.5	Brake accumulator pressure sensor B19 <i>L538-1559;</i>	020-29
020.8.6	Parking brake hydro accumulator <i>L538-1559;</i>	020-30
020.9	Electrical system	020-31
020.9.1	Central control unit (Master 4) <i>L538-1559;</i>	020-31
020.9.2	Compact module <i>L538-1559;</i>	020-31
020.9.3	Battery <i>L538-1559/0-48346;</i>	020-31
020.9.4	Battery <i>L538-1559/48347-;</i>	020-32
020.9.5	Voltage transformer <i>L538-1559;</i>	020-32
020.10	Gearbox	020-33
020.10.1	Transmission <i>L538-1559;</i>	020-33
020.10.2	Gear shifting proportional solenoid valve Y60 <i>L538-1559;</i>	020-33
020.10.3	Output B1 speed sensor <i>L538-1559;</i>	020-33

- D) The value is reduced when the distance to the centre of gravity (SA) is above 600 mm
- E) FEM III forklift and prongs limit payload to 5000 kg
- F) Payload restricted by tilt cylinders of Z kinematics

### 020.1.6 Working attachment: log grapple

Valid for: L538-1559;

Values stated refer to machine:

- In standard version
- With 20.5R25 L3 tyres (For more information see: 020.11.4 Tyres, page 020-34)
- Including all lubricants
- With a full fuel tank
- With ROPS/FOPS cab and operator
- On level and stable ground



**Note**

Tyres and working attachments affect operating weight and payload.

► Note the information about the tyres and working attachment.

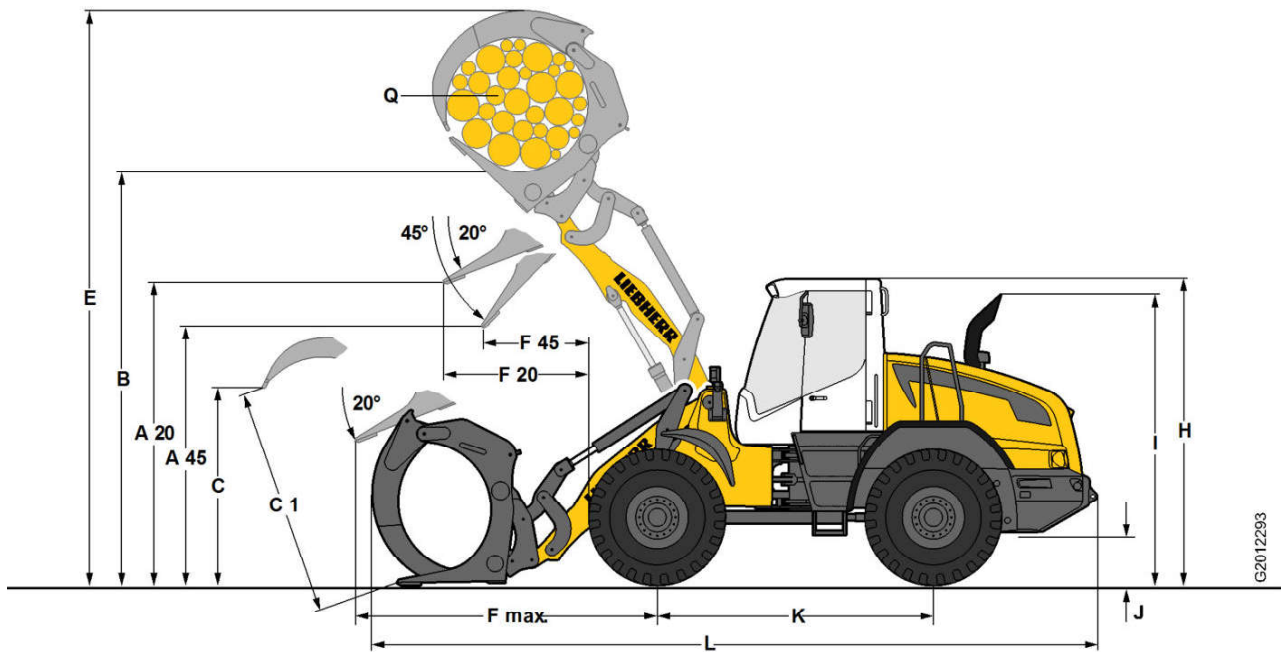

Fig. 86: Working attachment: log grapple

	Designation	Unit	Value
	Hydraulic quick coupler		Yes
	Load geometry		A)
A20	Unloading height at 20°	mm	3205
A45	Unloading height at 45°	mm	2720
B	Manipulation height	mm	4370

LBH/12204898/11211-20190801\_073806/en

G2012293

## 020.5 Travel hydraulics

### 020.5.1 Travel pump

Valid for: L538-1559;

Description	Unit	Value
Type		A4VG085EV2DP/ 40MR
Replenishing pump type		Internal gear pump
Variable displacement pump type		Axial piston pump with swash plate variable displacement
Direction of rotation		Clockwise
Displacement per turn of the replenishing pump	cm <sup>3</sup>	19
Maximum displacement of replenishing pump	l/min	46.5
Maximum displacement per turn of the variable displacement pump	cm <sup>3</sup>	85
Maximum displacement of variable displacement pump	l/min	210
Weight	kg	77

### 020.5.2 Travel pump high pressure sensor B45

Valid for: L538-1559;

Description	Unit	Value
Measuring range	bar	0 to 600
Signal output	mA	4 to 20
Supply voltage	VDC	8 – 30
Rated temperature range	°C	-25 to +85
Tightening torque	Nm	20

### 020.5.3 Travel motor 1

Valid for: L538-1559;

Description	Unit	Value
Type		A6VM060HA1R2
Type		Axial piston motor with inclined-axis

## 020.10 Gearbox

### 020.10.1 Transmission

Valid for: L538-1559;

Description	Unit	Value
Type		319
Travel motor 1 ratio		1.55
Travel motor 2 ratio		3.83

### 020.10.2 Gear shifting proportional solenoid valve Y60

Valid for: L538-1559;

Description	Unit	Value
Coil resistance	ohms	8.8
Control voltage range	mA	1050
Supply voltage	VDC	24
Rated temperature range	°C	-30 to +80

### 020.10.3 Output B1 speed sensor

Valid for: L538-1559;

Description	Unit	Value
Type		Hall sensor
Number of teeth at the measuring point		49

### 020.10.4 Travel motor 2 speed sensor B2

Valid for: L538-1559;

Description	Unit	Value
Type		Hall sensor
Number of teeth at the measuring point		84

# 030 Maintenance

## Contents

030.1	Maintenance and inspection schedule	030-10
030.2	Filling quantities and lubrication chart	030-15
030.2.1	Recommended lubricants <i>L538-1559;</i>	030-15
030.2.2	Recommended operating fluids <i>L538-1559;</i>	030-16
030.3	Lubricants and fuels	030-17
030.3.1	General information on lubricants and fuels	030-17
030.3.1.1	General questions	030-17
030.3.1.2	Safety data sheets	030-17
030.3.1.3	Technical data sheets	030-17
030.3.1.4	Specific Liebherr standards	030-17
030.3.2	General information on changing lubricants and fuels	030-17
030.3.3	Converting hydraulic system from mineral oils to biodegradable hydraulic fluids	030-18
030.3.4	Diesel fuels <i>L538-1559;</i>	030-18
030.3.5	Diesel exhaust fluid <i>L538-1559;</i>	030-19
030.3.6	Engine oils <i>L538-1559;</i>	030-19
030.3.7	Refrigerant <i>L538-1559;</i>	030-20
030.3.8	Coolant <i>L538-1559;</i>	030-20
030.3.9	Hydraulic oil <i>L538-1559;</i>	030-21
030.3.10	Gear oil <i>L538-1559;</i>	030-22
030.3.11	Axle oil <i>L538-1559;</i>	030-23
030.3.12	Lubrication grease <i>L538-1559;</i>	030-23

Customer:..... Machine type:..... Serial no.:..... Operating hours:..... Date:.....

Maintenance / inspection after service hours							Tasks to be performed				
On handover	All 8-10 h	All 50 h	All 500 h	All 1000 h	All 2000 h	Other intervals	Additional labelling	By maintenance staff	By authorised specialist staff	Confirm tasks	See page
								■ Once-only activity ● Repeat interval † If necessary ✱ Annually before the winter  <b>Additional labelling</b> ††† Assistance required † Have this task carried out exclusively by a certified electrician	□ Once-only activity ○ Repeat interval ✧ If necessary		
<b>Overall machine</b>											
<input type="checkbox"/>	●	●	○	○	○			Checking the machine is in the proper condition			030-29
	●	●	○	○	○			Remove loose parts, dirt, ice and snow from machine.			030-30
				○	○			Adjust the machine according to the testing and adjustment check-list.			
				○	○			Corrosion protection system for fittings and electrical contacts (option): Replacing VCI capsules (at least once a year).			030-33
<b>Drive group</b>											
<input type="checkbox"/>	●	●	○	○	○			Checking diesel engine oil level			030-42
			○	○	○			Diesel engine: Change the oil (at least once a year or according to the engine oil quality and complicating factors). <a href="#">(For more information see: 030.3.6 Engine oils, page 030-19)</a>			030-44
			○	○	○			Change the diesel engine oil filter (with every oil change).			030-46
			○	○	○			Checking the V-ribbed belt on the diesel engine			030-47
							✧	Change V-ribbed belt on the diesel engine.			030-48
						○3000 h		Check diesel engine valve clearance.			030-50
			○	○				Change the engine oil separator filter insert.			030-54
			○	○	○			Diesel engine: Check the crankcase bleeder system.			030-54
						○3000 h		Diesel engine: Check the glow plugs.			030-55
<input type="checkbox"/>			○	○	○		†	Drain the condensate and sediment from the fuel tank.			030-56
	●	●	○	○	○			Drain off condensate from the fuel pre-filter.			030-57
			○	○	○			Fuel pre-filter: Change the filter element.			030-58
			○	○	○			Change the fuel fine filter element.			030-60
						○4500 h		Exhaust system: change filter cartridge of diesel exhaust fluid pump (at least every 3 years).			030-61
	●	○	○	○				Air filter system: Clean the service cover and dust discharge valve.			030-62
			○	○			†	Clean or change the main element of the air filter system (when indicated by the vacuum switch, or at least once a year).			030-63
				○			†	Air filter system: Clean the safety element (after replacing the main element three times, or every year at the latest).			030-66
			○	○	○			Diesel engine: Check that the intake and exhaust system is in good condition and not loose or leaking.			030-67

LBH/12204898/11/21+20190801\_073806/en

### 030.3.8.3 Minimum quality requirement

Specification
ASTM D6210
LH-01-COL3A

Tab. 42: Specification

When using coolant from other manufacturers, you must obtain information from the **Liebherr Lubricant Hotline**.

### 030.3.9 Hydraulic oil

Valid for: L538-1559;

#### 030.3.9.1 Liebherr recommendation

Ambient temperature	Designation
	<b>Liebherr mineral oil</b>
From -40 °C to 45 °C	Liebherr Hydraulic HVI
From -10 °C to 45 °C	Liebherr Hydraulic Basic 68
	<b>Liebherr-PAO<sup>42)</sup> biodegradable</b>
From -20 °C to 45 °C	Liebherr Hydraulic Plus

Tab. 43: Recommendation for hydraulic oils

#### 030.3.9.2 Minimum quality requirement

Specification
EMT LH-00-Minimum-HYE

Tab. 44: Minimum quality requirement

When using hydraulic oils from other manufacturers, information on the oil change intervals must be obtained from the manufacturer or supplier.

#### 030.3.9.3 Oil analysis

	Hydraulic oil	Interval
Normal use (oil analysis optional)	<b>Mineral oil</b>	
	Liebherr Hydraulic HVI	First after 1000 h, then every 1000 h, at least once a year
	Liebherr Hydraulic Basic 68	

<sup>42)</sup> PAO = polyalphaolefin

Clean the machine immediately after the following work:

- Working in salty environments (for example contact with road salt, or by the sea)
- Working with alkaline or acidic substances
- Working with corrosive materials (such as lime compounds or cement)

---

#### NOTICE

Always carry out cleaning correctly  
Risk of damage to the machine.

- ▶ Only clean electrical systems, cables and wiring harnesses with low-pressure equipment.
  - ▶ Only clean soundproofing material with low-pressure equipment.
  - ▶ When new (or after respraying), do not clean the machine with a high-pressure cleaner for two months.
  - ▶ Observe the operating manual of the high-pressure cleaner.
- 



---

#### CAUTION

High-pressure jet!  
Risk of injury.

- ▶ Wear protective clothing and safety glasses.
- 

## Cleaning the outside of the machine

### Before cleaning

Make sure that the following requirements are fulfilled:

- The machine is in maintenance position 2.

Before washing with water or with a high-pressure cleaner, carry out the following tasks in order to prevent water from getting inside.

- ▶ Lubricate all bearings and pin connections.
- ▶ Clean oil, fuel and maintenance products from all connections and bolts.

If components behind openings have to be prevented from water getting in:

- ▶ Cover or mask the openings.

Components particularly at risk are:

- Electric motors
- Control units
- Electrical components
- Relay boards and fuse boards
- Plug connections
- Sensors
- Air filter
- Exhaust system

### Cleaning

- ▶ Do not clean the machine with aggressive cleaning agents or combustible liquids.
- ▶ Soften up dirt with water.
- ▶ Rinse off the softened dirt with water.

If the engine has to be cleaned:

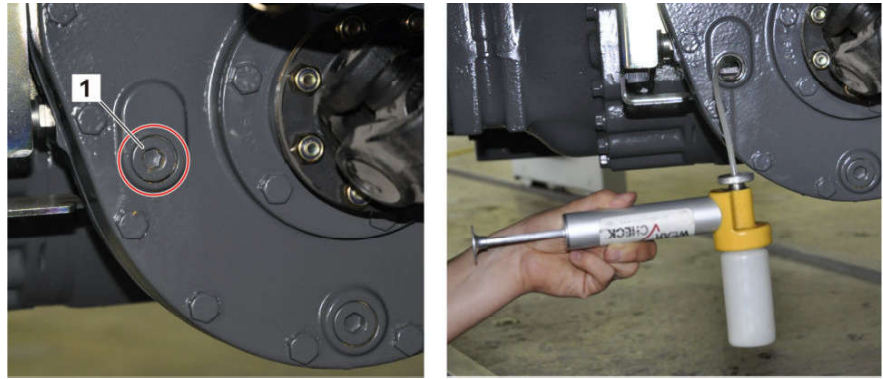

Fig. 116: Sampling point on the transmission

**1** Filling plug

- ▶ Start the engine and accelerate the machine to 15 km/h.
  - ▷ The oil is circulated.
- ▶ Turn off the engine.
- ▶ Put the machine in maintenance position 1.



**WARNING**

Hot, pressurised liquid!  
Beware of burns.

- ▶ Carefully unscrew the filling plug.
  - ▶ Wear safety glasses.
  - ▶ Avoid skin contact with fluids.
- 
- ▶ Carefully unscrew the filling plug 1.
  - ▶ Insert the sampling hose and take the oil sample.
  - ▶ Close the filling plug 1 again.

**Axles**

The oil sample from the axles is taken from the differential housing using a hand pump.

Make sure that the following requirements are fulfilled:

- The machine is in maintenance position 1.
- The service access is open.
- A hand pump and analysis kit are available.

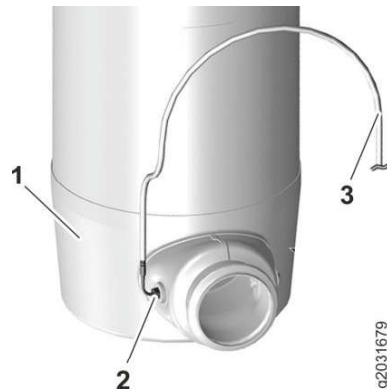

Fig. 127: Removing the SCR inlet temperature sensor

- |   |                              |   |                  |
|---|------------------------------|---|------------------|
| 1 | SCR catalytic converter      | 3 | Electrical cable |
| 2 | SCR inlet temperature sensor |   |                  |

- ▶ Remove the SCR inlet temperature sensor 2 on the SCR catalytic converter 1.
- ▶ Disconnect the electrical cable 3.
  - ▷ The diesel particulate filter can be removed.
- ▶ Remove the diesel particulate filter.

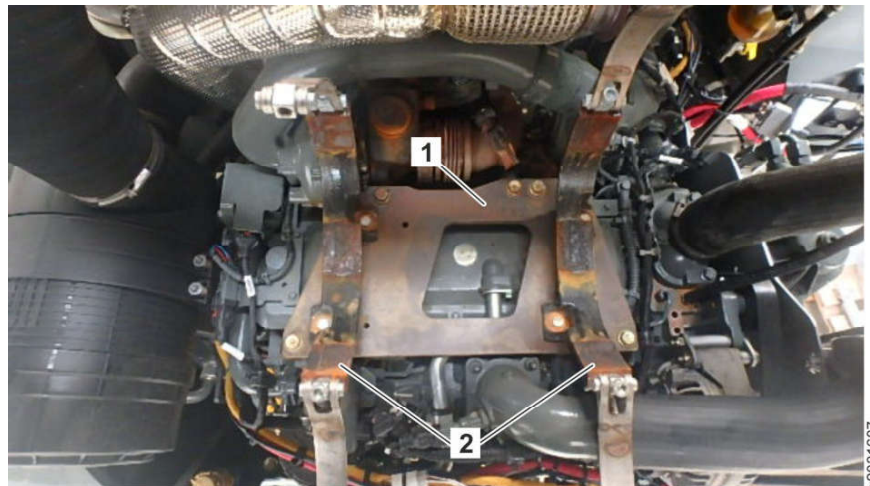

Fig. 128: Remove the filter brackets and mounting plate.

- |   |                |   |                 |
|---|----------------|---|-----------------|
| 1 | Mounting plate | 2 | Filter brackets |
|---|----------------|---|-----------------|

- ▶ Remove the filter brackets 2.
- ▶ Remove the mounting plate 1.

- ▶ Lubricate the seal ring of the new filter element **2** with clean fuel.
- ▶ Screw the new filter element **2** onto the filter base **1** and tighten it by hand.
- ▶ Turn on the ignition for 60 seconds.
  - ▷ The fuel system is automatically bled.

#### 030.4.4.14 Exhaust system: changing filter cartridge of diesel exhaust fluid pump

Valid for: L538-1559;

Make sure that following requirements are met:

- Machine is in maintenance position 1.
- Service access is open.

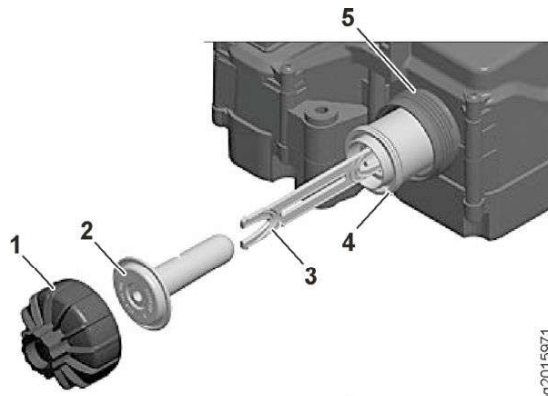

Fig. 139: Changing the filter cartridge of the diesel exhaust fluid pump

- |          |  |          |                                    |
|----------|--|----------|------------------------------------|
| <b>1</b> | Diesel exhaust fluid filter cover              | <b>4</b> | Diesel exhaust fluid filter        |
| <b>2</b> | Diesel exhaust fluid filter equalising element | <b>5</b> | Diesel exhaust fluid metering unit |
| <b>3</b> | Filter removal tool                            |          |                                    |

The diesel exhaust fluid metering unit **5** is installed in the cooler mount.

The filter removal tool **3** and a new equalising element **2** are supplied with the new diesel exhaust fluid filter **4**.

- ▶ Remove the diesel exhaust fluid filter cover **1**.
- ▶ Remove the diesel exhaust fluid filter equalising element **2**.

The ends of the filter removal tool **3** are labelled "BLACK" and "GREY". In this case, the "BLACK" side must be used.

- ▶ Insert the filter removal tool **3** into the diesel exhaust fluid filter **4** until it latches into place.
- ▶ Pull out the diesel exhaust fluid filter **4**.
- ▶ Clean the thread and the contact faces of the diesel exhaust fluid metering unit **5** with distilled water.
- ▶ Lubricate the O-rings of the new diesel exhaust fluid filter **4** with clean engine oil.
- ▶ Put the new diesel exhaust fluid filter **4** into the diesel exhaust fluid metering unit **5**.
- ▶ Put in the new diesel exhaust fluid filter equalising element **2**.
- ▶ Tighten the diesel exhaust fluid filter cover **1** to 23 Nm.

### Installing a new diesel particulate filter module

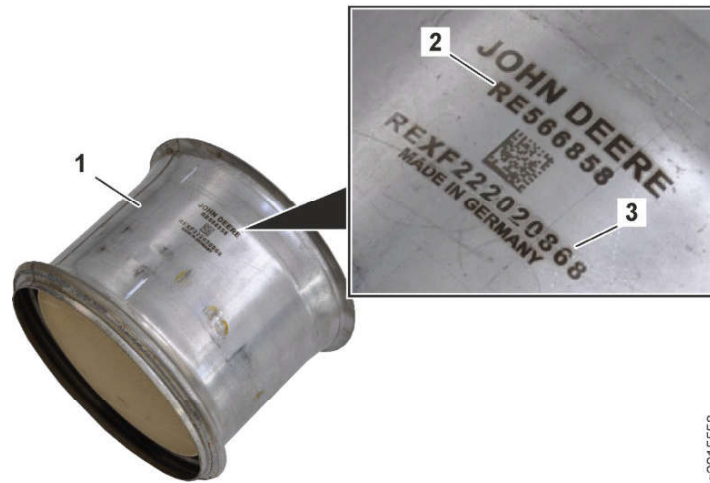

g2015558

Fig. 150: Diesel particulate filter module

- |                                    |                 |
|------------------------------------|-----------------|
| 1 Diesel particulate filter module | 3 Serial number |
| 2 Part number                      |                 |



**Note**

To confirm the change of the diesel particulate filter in the Service Advisor, the part number 2 and the serial number 3 are required.

► Make a note of the part number and the serial number.

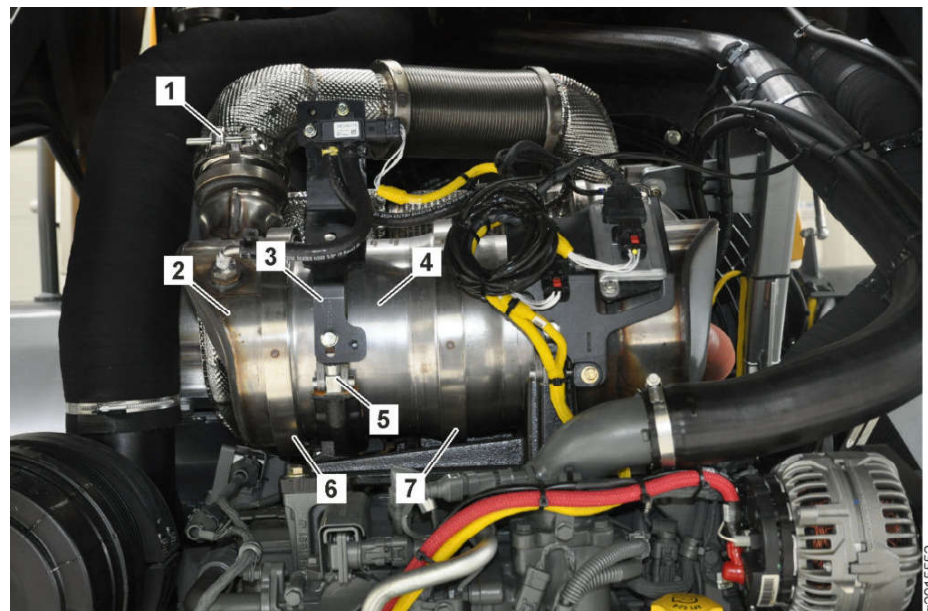

g2015552

Fig. 151: Changing the diesel particulate filter

- |                                    |   |
|------------------------------------|---|
| 1 Exhaust pipe profile clip        | 5 Fastening clip  |
| 2 Output module                    | 6 Profile clip for diesel particulate filter module and output module |
| 3 Retaining plate                  | 7 Profile clip for diesel particulate filter module and input module  |
| 4 Diesel particulate filter module |   |

LBH/12204898/1121+20190801\_073806/en





Make sure that following tools are ready:

- Feeler gauge
- Laptop with Sculi diagnostic software
- Torque wrench

### Preparations

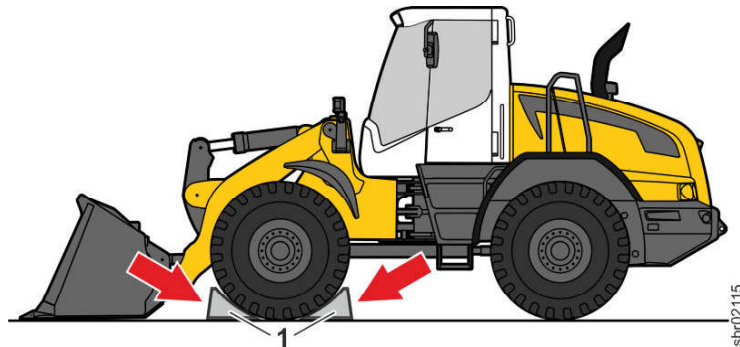

Fig. 180: Use chocks to secure the machine against rolling away

- ▶ Start diesel engine.
- ▶ Lay bucket flat on ground.
- ▶ Turn off diesel engine.
- ▶ Use chocks 1 to secure machine against rolling away.

### Checking wear on brake linings

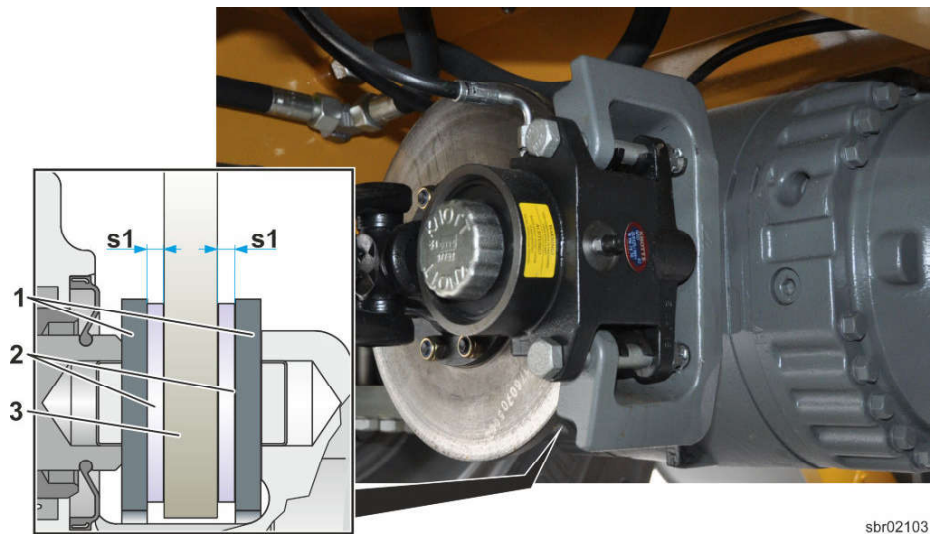

Fig. 181: Checking wear on brake linings

- 1 Brake shoe
- 2 Brake lining
- 3 Brake disc
- s1 Brake lining thickness

- ▶ Check that both brake linings 2 are required thickness s1.

Description	Unit	Value
Minimum thickness s1 of each brake lining	mm	1.0

LBH/12204898/11/21+20190801\_073606/en



Fig. 188: Button cover and buttons

- 1 Button cover  
2 Screws

- 3 Buttons

- ▶ Loosen the screws 2.



#### Note

- ▶ To remove the button cover 1 more easily, push together the two grips of the control lever.
- ▶ Note that the buttons 3 are different sizes.

- ▶ Take off the button cover 1.



Fig. 189: Fitting the button cover

- 4 Anti-twist lock

- ▶ Fit the buttons 3 in the new cover 1.
- ▶ Fit the button cover on the control lever. Pay attention to the anti-twist lock 4.



#### Note

To stop the buttons 3 from falling out of the cover 4 during assembly:

- ▶ Gently press the three buttons from outside to hold them in place.

- ▶ Tighten the screws 2 to 0.5 Nm.

### 030.4.12.2 Service hatches: Cleaning and maintaining the seals

Valid for: L538-1559;

Make sure that the following requirements are fulfilled:

- The machine is in maintenance position 1.
- The service access is open.

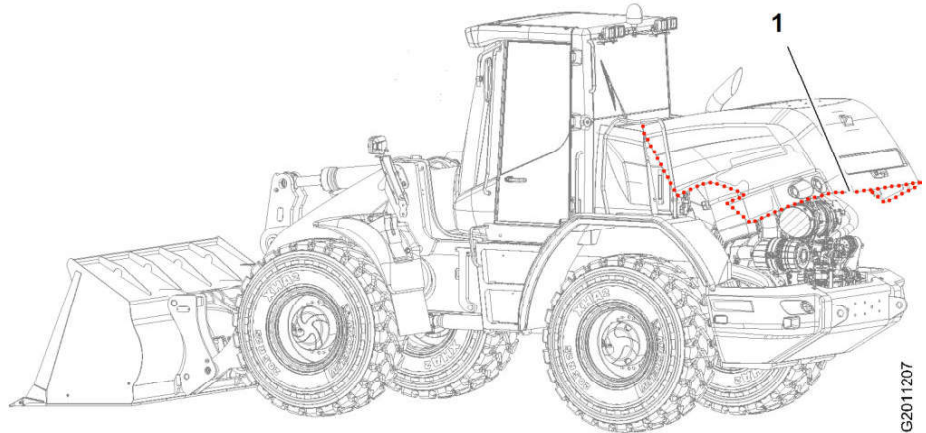

Fig. 201: Service hatches: Cleaning and maintaining the seals

1 Engine hood seal

- ▶ Wipe the seal 1 with a damp cloth.
- ▶ Apply silicon spray to the seal 1.
- ▶ (For more information see: [Opening and closing the engine hood, page 030-26](#))

### 030.4.13 Working attachment

#### 030.4.13.1 Lubricating the lift arms and working attachment

Valid for: L538-1559;

For jobs that require daily cleaning, the lift arms and attachment must be lubricated every day.

Make sure that the following requirements are fulfilled:

- The machine is in maintenance position 2.
- The lubrication point has been cleaned.



### 030.4.15.3 Central lubrication system: Checking the lubrication of the bearings

*Valid for: L538-1559;*

This equipment is optional.

Make sure that the following requirements are fulfilled:

- The machine is in maintenance position 2.
- ▶ Visually examine whether metered quantities are adequate at the bearing points.

---

#### **NOTICE**

Insufficient lubrication!

Damage to the bearings.

- ▶ Lubricate more often.
-

- ▶ Warm up the hydraulic oil and coolant until they reach their operating temperature.

Description	Unit	Value
Hydraulic oil operating temperature	°C	58 ±5
Coolant operating temperature	°C	85 ±5

### After completing testing and adjustment

- ▶ Remove the cardboard covering from the hydraulic oil cooler.

### 030.6.2.3 Service management

Valid for: L538-1559;

Symbols in the display indicate to the driver that a service is due. See the operating manual for more information.

When a technician has carried out a service, this must be confirmed using the Sculi diagnostic software.

In the service management, service codes are saved in the central control unit under the following conditions:

- Service message hidden by the operator within the specified period
- Service confirmed by the technician within the specified period
- Service confirmed by the technician outside the specified period
- Service not confirmed

### Confirming service

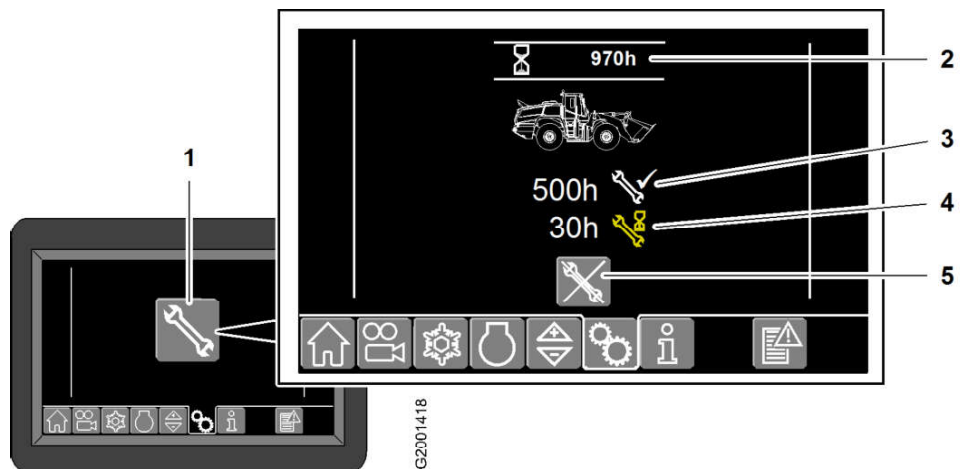

Fig. 225: Service management

- |   |   |   |                                    |
|---|---|---|------------------------------------|
| 1 | Service management button                   | 4 | Operating hours until next service |
| 2 | Machine operating hours                     | 5 | Hide service message button        |
| 3 | Operating hours when service last confirmed |   |                                    |

- ▶ Connect the Sculi diagnostic software to the machine.
- ▶ In the variables editor, select the **Service management** folder.
- ▶ Set **MXServiceACK** variable to **1**.
  - ▷ After a short time, variable **MXServiceACK** returns to **0**.

If a required value is not reached:

- ▶ Repeat calibration.

If required values are reached:

- ▶ Calibrate bucket position angle sensor.

### Manual calibration of bucket position angle sensor

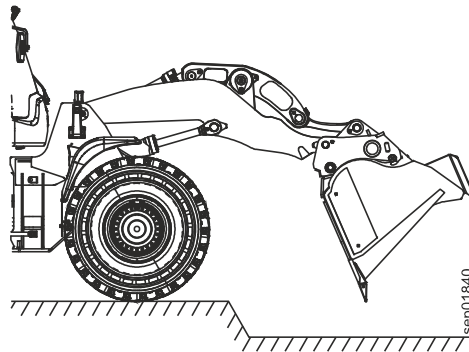

Fig. 233: Setting up machine



#### Note

To calibrate bucket position angle sensor, lift arms must be moved to a position where tilt cylinder can be fully extended and retracted. A large bucket can scrape ground.

- ▶ If necessary, set up machine so that bucket does not scrape ground or remove bucket before calibration (with quick coupler).



Fig. 234: Screen for "positioning lift arms"

- |   |                                    |   |                             |
|---|------------------------------------|---|-----------------------------|
| 1 | Actual lift arm position indicator | 3 | Starting calibration button |
| 2 | Target lift arm position indicator |   |                             |

- ▶ Raise lift arms half way.
- ▶ Tilt bucket out.
- ▶ Set variable **MXSIWStartBuckAngleAdj** to **1**.
  - ▷ Display changes to "positioning lift arm" screen for 20 seconds.
- ▶ Position lift arms so that *actual lift arm position* indicator **1** lights up green.
  - ▷ Tilt cylinder can fully extend and retract.

**NOTICE**

There is no secondary pressure relief valve for lowering function.  
Irreparable damage to working pump.

- ▶ Do not activate lowering function as far as it will go.
- ▶ At 1300 min<sup>-1</sup>, activate in succession lifting, tilting out and tilting in functions, as well as optional additional functions, as far as they will go and then operate fully.
- ▶ While doing so, check whether high pressure PA corresponds to specified value.

Description	Unit	Value
High pressure PA during tilt in 2 function	bar	360 ±5
High pressure PA during tilt out 3 function	bar	360 ±5
High pressure PA during lift 4 function	bar	420 ±5
High pressure PA during 3rd function B3 (option) 5	bar	250 ±5
High pressure PA during 3rd function A3 (option) 6	bar	250 ±5
High pressure PA during 4th function B4 (option) 7	bar	250 ±5
High pressure PA during 4th function A4 (option) 8	bar	250 ±5

If a required value is not reached:

- ▶ Set bucket down on ground on its teeth or cutting edge.
- ▶ Turn off diesel engine and take out ignition key.
- ▶ Turn adjusting screw of corresponding secondary pressure relief valve.

**Note**

To adjust secondary pressure relief valves:

- ▶ Turn adjusting screw clockwise to increase high pressure.
- ▶ Turn adjusting screw anticlockwise to reduce high pressure.

- ▶ Repeat check and adjustment until required value is reached.

When all required values are reached:

- ▶ Set bucket down on ground on its teeth or cutting edge.
- ▶ Turn off diesel engine and take out ignition key.
- ▶ Unscrew the adjusting screw on the working hydraulics LS pressure cut-off valve 1 by exactly one turn.
- ▶ Check and adjust the working hydraulics LS pressure cut-off.



Fig. 244: Moist surfaces, no visible oil leak

- ▶ Document the damage and observe whether the condition deteriorates.
- If the condition deteriorates:
- ▶ Replace the hydraulic lines.

### Medium damage to the hydraulic lines

#### Cracks or cuts up to the steel fabric or steel fabric exposed due to damage to the outer jacket

The damage to the outer jacket (such as cracks, cuts or abrasions) through which the steel fabric is exposed is classified as medium damage if the steel fabric is undamaged. Damage to the steel fabric is classified as severe damage.



Fig. 245: Cracks or cuts up to the steel fabric or steel fabric exposed due to damage to the outer jacket

- ▶ In the variables editor, select the **Block curve calibration** folder.
- ▶ Set the variable **MXdrBlockMan** to **1**.
  - ▷ Machine is in blocked condition.

**Note**

The variable **MXdrBlockMan** is automatically reset to its original value **0** when the ignition is switched **OFF**.

- ▶ If necessary, reset the value to **1** when repeating the test.

**DANGER**

Unintentional movement of the machine!  
Fatal injury.

- ▶ Make sure there is nobody in danger area.
  - ▶ Be ready to brake.
- 
- ▶ Select forward travel direction.
  - ▶ Carefully increase the engine speed to the maximum.
  - ▶ Check that the high pressure **MH** corresponds to the required value.

Description	Unit	Value
High pressure <b>MH</b>	bar	440 $\pm 10$

If required value is not reached:

- ▶ Turn off diesel engine and take out ignition key.
- ▶ Adjust pressure cut-off **1** adjusting screw.

**Note**

To adjust the pressure cut-off:

- ▶ Turn the adjusting screw clockwise to increase the high pressure.
- ▶ Turn the adjusting screw anticlockwise to reduce the high pressure.

- ▶ Repeat check and adjustment until required value is reached.

If required value is reached:

- ▶ Repeat check.
- ▶ Check that engine droop corresponds to the required value.

Description	Unit	Value
Maximum engine droop	min <sup>-1</sup>	50

If the engine droop is too great:

- ▶ Inspect the travel hydraulics for damage.
- ▶ If in doubt, contact technical customer service department.

If the engine droop is within the permitted range:

- ▶ Turn off diesel engine and take out ignition key.
- ▶ Disconnect pressure gauge from high pressure test connection **MH**.

## Automatic calibration of proportional solenoids for main spool valve and emergency spool valve



### Note

Before calibration of proportional solenoids of emergency spool valve, calibrate position sensor of main spool valve!

- ▶ Make sure that the articulation lock is disengaged.
- ▶ Start diesel engine.
- ▶ Raise the lift arms slightly.
- ▶ Make sure that joystick steering is **not** activated (*joystick steering* switch in position 0; for more information see: operator's manual).



### WARNING

Automatic machine movements!  
Injury.

- ▶ Make sure there is nobody in danger area around machine.
- ▶ Set variable ***MXJSSteerValveAdjMvBg*** to **1**.
  - ▷ Calibration takes place automatically.
  - ▷ The machine automatically performs from minimal steering movements.
  - ▷ The calibration can be cancelled by steering with the steering joystick or starting up.
- ▶ Wait until the variable ***MXJSSteerValveAdjMvBg*** returns to **0**.
  - ▷ Calibration is completed.
- ▶ Check that calibration was successful.

### Checking whether calibration is successful

- ▶ Activate joystick steering.
- ▶ Perform a few steering movements with the joystick steering.
- ▶ Check whether the joystick steering is working properly.

If the joystick steering is not working properly:

- ▶ Repeat calibration.

### 030.6.8.3 Control valve block: Steering system LS pressure cut-off

Valid for: L538-1559;

Make sure that the following requirements are fulfilled:

- The hydraulic oil is at operating temperature.
- The machine is in the maintenance position for adjustment procedures.
- The service hatches are open.

Make sure that the following tools are ready:

- Pressure gauge (600 bar)
- Laptop with Sculi diagnostic software

On machines without a touch screen display or where the touch screen display is not working, the service file is generated using the “SCOTTI” function in the Sculi diagnostic software.

After replacing an electrical or electronic component, a complete service file must be sent to the following e-mail address:

[lbh.maschinenfeedback@liebherr.com](mailto:lbh.maschinenfeedback@liebherr.com)



#### Note

Liebherr will only accept service files if the following conditions are met:

- ▶ The file name may not be changed.
- ▶ The service file is only complete if the entire contents of the folder are available. Individual files are not acceptable.



#### Note

Folders cannot be added to e-mails as attachments.

- ▶ Send folders as a Zip-File.

Files in the service file	Description
today.mde	Files with the extension <b>.mde</b> contain machine data and recordings of machine operation.
service.cor	This file contains information on adjustment data and enabled functions on the machine.
service.err	This file contains service codes and messages from the central control unit.
service.ret	This file contains machine variables.
service.ver	This file can be opened using the Sculi diagnostic software. The information corresponds to the “Info” function in Sculi.
service.varx	This file can be opened using the Sculi diagnostic software. This file contains machine variables and adjustment data.

Tab. 76: Files in the service file

## Generating the service file using the “SCOTTI” function on the touch screen display

The following information is required to create a service file:

Designation	Item code	Remark
Memory card	10223095	To save the service file
Memory card reader	11000491	To read the memory card

Tab. 77: Required equipment

Make sure that the following requirements are fulfilled:

- The machine is in maintenance position 1.

The following tools are required to test the CAN line:

- ❑ Multimeter (resistance metering, voltage metering)
- ❑ Metering leads (ID number 11006220 and 11006221)
- ❑ Metering points (ID number 884191214 and 884191114)

### Resistance measurements on the CAN line

The following faults can be detected by resistance measurements on the CAN line:

- A break in the CAN line.
- The function of both 120 Ω resistors.
- Short circuit to earth.
- Short circuit to machine voltage.
- Short circuit between CAN HIGH and CAN LOW.



#### Note

Do not take resistance measurements while the circuit is live!

The resistance measurements of live components can be incorrect, because the measured value is distorted by the connected voltage.

- ▶ Turn off the battery main switch.

#### Measuring the resistance between CAN HIGH and CAN LOW.

In the central control unit as well as in the last CAN node of the CAN line, a 120 Ω resistor has respectively been installed. These resistors are connected in parallel so that the total resistance is 60<sup>±5</sup> Ω.

The following faults can be detected with this measurement:

- A break in the CAN line.
- The function of both 120 Ω resistors.
- Short circuit between CAN HIGH and CAN LOW.
- The absence of a terminal resistor.

Make sure that the machine is in maintenance position 1.

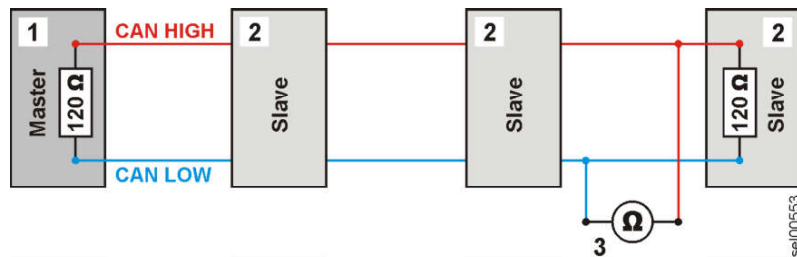

Fig. 279: Measuring the resistance between CAN HIGH and CAN LOW.

- 1 Central control unit (Master4)
- 2 CAN node
- 3 Multimeter

- ▶ Connect the multimeter to CAN HIGH and to CAN LOW on the CAN line.
- ▶ Set the multimeter to ohm metering.
- ▶ Measure the resistance.

Measurement	Diagnosis	Malfunction
Resistance of 60 <sup>±5</sup> Ω	There is no break in the CAN line and both 120 Ω resistors function properly.	No

LBH/12204898/11211-20190801\_073806/en

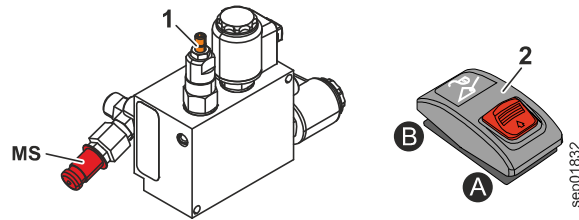

Fig. 285:

- 1** Pressure reducing valve for quick coupler      **MS** Quick coupler closing pressure test connection
- ▶ Connect a pressure gauge (600 bar) to the quick coupler closing pressure test connection **MS** on the quick coupler valve block.
  - ▶ Start the engine.
  - ▶ At lower idling speed, push the *quick coupler* button to position **B** and hold it there.
  - ▶ When doing so, check whether the quick coupler closing pressure **MS** is correct.

Description	Unit	Value
Quick coupler closing pressure <b>MS</b>	bar	250 $\pm 10$

If the value is not correct:

- ▶ Turn off the engine and take out the ignition key.
- ▶ Turn the adjusting screw of the pressure reducing valve **1**.

**Note**

To adjust the pressure reducing valve:

- ▶ Turning the adjusting screw clockwise increases the pressure.
- ▶ Turning the adjusting screw anticlockwise reduces the pressure.

- ▶ Check and repeat the adjustment until the value is correct.

If the value is correct:

- ▶ Turn off the engine and take out the ignition key.
- ▶ Remove the pressure gauge from the quick coupler closing pressure test connection **MS**.

### 030.6.13.2 Parameters for lift arm geometry

Valid for: L538-1559;

**Note**

The parameters for the lift arm geometry are necessary in order to correctly calculate the lift arm position.

- ▶ Make sure the correct parameters are set.

Make sure that following tools are ready:

- Laptop with Sculi diagnostic software

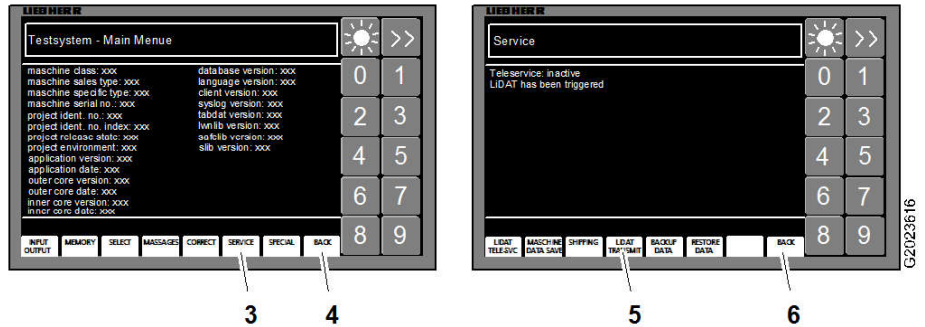

Fig. 299: Activating data transmission manually

- |          |                       |          |                              |
|----------|-----------------------|----------|------------------------------|
| <b>3</b> | <b>SERVICE</b> button | <b>5</b> | <b>LIDAT TRANSMIT</b> button |
| <b>4</b> | <b>BACK</b> button    | <b>6</b> | <b>BACK</b> button           |

- ▶ Press the button **3**.
  - ▷ Next screen is opened.
- ▶ Press the button **5**.
  - ▷ Data transmission is started and may take several minutes.
- ▶ Wait 5 minutes.
  - ▷ Data transmission is completed.
- ▶ Press the button **6**.
  - ▷ Previous screen is opened.
- ▶ Press the button **4**.
  - ▷ Service screen is displayed.
  - ▷ The machine can continue to be operated.

exhaust flow is throttled. The exhaust temperature increases. Higher exhaust gas temperatures are required for DPF regeneration.

The exhaust throttle valve is actuated by the electrically controlled servo motor. The engine control unit sends the desired position specifications to the servo motor of the exhaust throttle valve and monitors the exhaust throttle valve position signal.

Engine coolant is directed through the exhaust throttle valve servo motor to prevent it from overheating.

### 2.3 Exhaust manifold pressure sensor

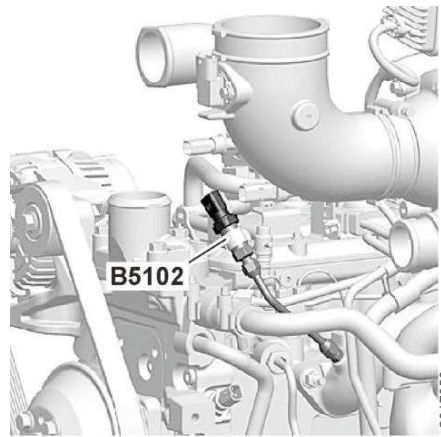

*Fig. 307: Exhaust manifold pressure sensor B5102*

The exhaust manifold pressure sensor **B5102** provides feedback for the control systems of the throttle valve servo motor in order to maximise engine performance while complying with emissions standards.

Before active regeneration of the diesel particulate filter, the engine control unit changes the position of the exhaust throttle valve. This produces the ideal pressure in the exhaust manifold, leading to the maximum inlet temperature in the diesel oxidation catalytic converter (DOC).

The engine control unit uses the exhaust manifold pressure to calculate the volumetric efficiency.

The machine can still be operated by bypassing the CAN line until a new fuel level sensor has been fitted. The *fuel level reserve* symbol field flashes. A service code is not shown.

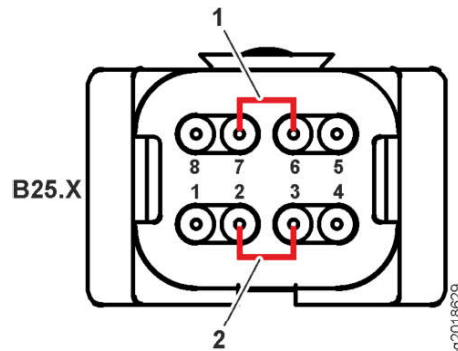

Fig. 322: Plug B25.X

- 1 CAN High jumper
- 2 CAN Low jumper

In order to bypass the fuel level sensor, first unplug the connector **B25.X** .

Then connect pin 7 to pin 6 and pin 2 to pin 3 on the connector **B25.X** .

The fuel level sensor is thereby bypassed in the CAN line and the machine can continue being operated.

### 040.1.3.3 Fuel pre-filter

Valid for: L538-1559;

#### 1 Layout

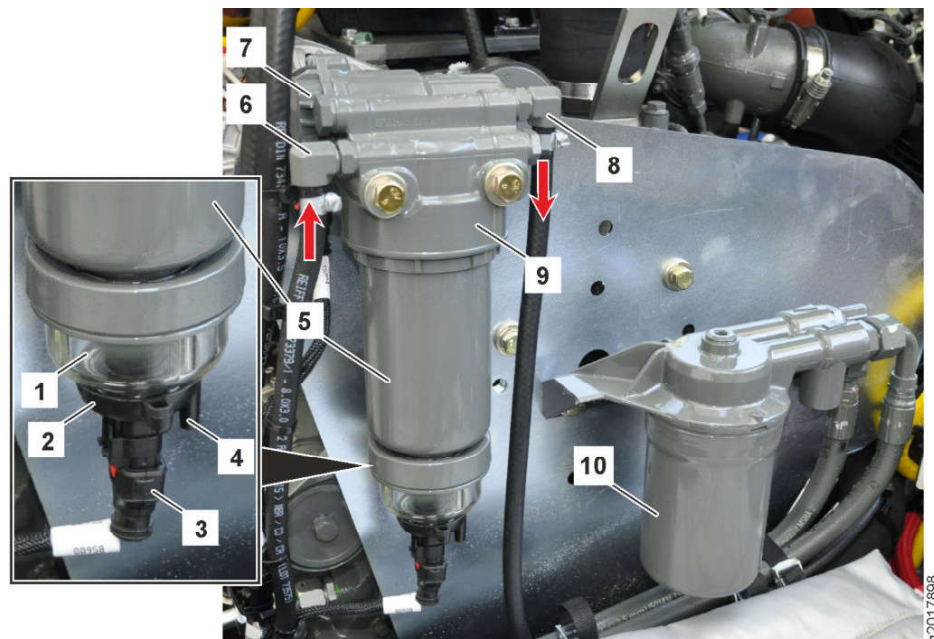







Fig. 323: Fuel pre-filter

- 1 Water separator container
- 6 Fuel from the fuel tank

*See next page for continuation of the image legend*

LBH/12204898/1121+20190801\_073606/en

g2017868

Symbol	Meaning	Notes
	Active regeneration is deactivated.	For use in fire hazard zones or during working cycles with very little engine load.
	The diesel particulate filter is dirty. Manual regeneration can be carried out.	Leave the fire hazard zone. Start regeneration as soon as possible.
 	The diesel particulate filter is very dirty. This results in reduced engine power. Carry out manual regeneration immediately.	Leave the fire hazard zone before regeneration.
 	The diesel particulate filter is overloaded. This results in greatly reduced engine power. Regeneration must be carried out by Liebherr customer service.	Beware of damaging the filter. Turn off the engine. Carry out service regeneration with the "John Deere Service ADVISOR".

Tab. 89: Symbols in the display

# 050 Cooling system

## Contents

050.1	Overview of the cooling system <i>L538-1559;</i>	050-2
050.2	Cooling system hydraulics	050-3
050.2.1	Overview of cooling system hydraulics <i>L538-1559;</i>	050-3
050.2.2	Fan pump <i>L538-1559;</i>	050-7
050.2.3	Fan motor <i>L538-1559;</i>	050-8
050.3	Cooling system electronics	050-12
050.3.1	General overview of electronic control system <i>L538-1559;</i>	050-12
050.3.2	Temperature sensor for coolant <i>L538-1559;</i>	050-15
050.3.3	Hydraulic oil temperature sensor <i>L538-1559;</i>	050-17
050.3.4	Temperature sensor for charge air <i>L538-1559;</i>	050-18
050.4	Cooler	050-20
050.4.1	Cooler unit <i>L538-1559;</i>	050-20
050.5	Reversible fan drive	050-21
050.5.1	Overview of the reversible fan drive <i>L538-1559;</i>	050-21
050.5.2	Fan reversal valve block <i>L538-1559;</i>	050-23

primary piston 6. Fan speed proportional pressure valve thus protects hydraulics of cooling system from excessive pressure.

# 050.5 Reversible fan drive

## 050.5.1 Overview of the reversible fan drive

Valid for: L538-1559;

This equipment is optional.

### 1 Layout

The reversible fan drive consists of the following components:

- Hydraulic tank (For more information see: 080.2.1 Overview of the hydraulic tank, page 080-6)
- Collector pipe
- Fan pump (For more information see: 050.2.2 Fan pump, page 050-7)
- Fan reversal valve block (For more information see: 050.5.2 Fan reversal valve block, page 050-23)
- Fan motor with fan
- Hydraulic oil cooler

### 2 Function

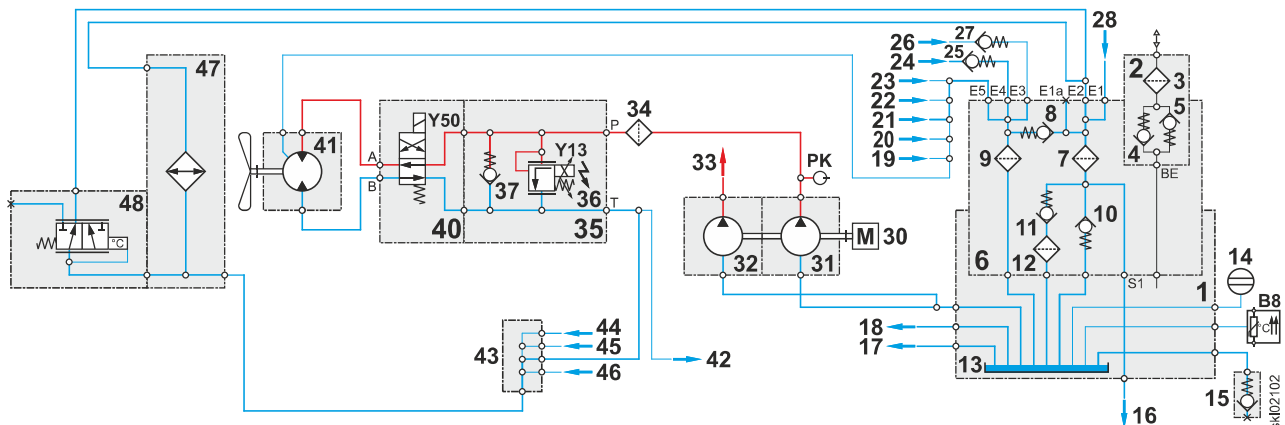

Fig. 359: Overview of reversible fan drive hydraulics: (engine running)

<b>1</b> Hydraulic tank	<b>16</b> Replenishing pump suction port	<b>32</b> Brake pump
<b>2</b> Breather filter	<b>17</b> Emergency steering pump suction port	<b>33</b> Oil supply for compact brake valve
<b>3</b> Fine filter	<b>18</b> Working pump suction port	<b>34</b> In-line filter 80 µm
<b>4</b> Outlet valve 0.65 bar	<b>19</b> Return flow from pilot control	<b>35</b> Fan reversal valve block
<b>5</b> Inlet valve 0.03 bar	<b>20</b> Return flow from servo pressure solenoid valve	<b>36</b> Fan speed proportional solenoid valve
<b>6</b> Return suction filter	<b>21</b> Compact brake valve return flow	<b>37</b> Replenishing valve
<b>7</b> Main filter element 10 µm	<b>22</b> Return flow from gear shifting proportional solenoid valve	<b>40</b> Fan reversal solenoid valve
<b>8</b> Bypass valve 2.5 bar	<b>23</b> Working pump leak oil	<b>41</b> Fan motor
<b>9</b> Return strainer 80 µm	<b>24</b> Return flow from servostat	<b>42</b> Travel motor 1 housing flushing

See next page for continuation of the image legend

LBH/12204698/11/21+20190601\_073606/en

2 Function

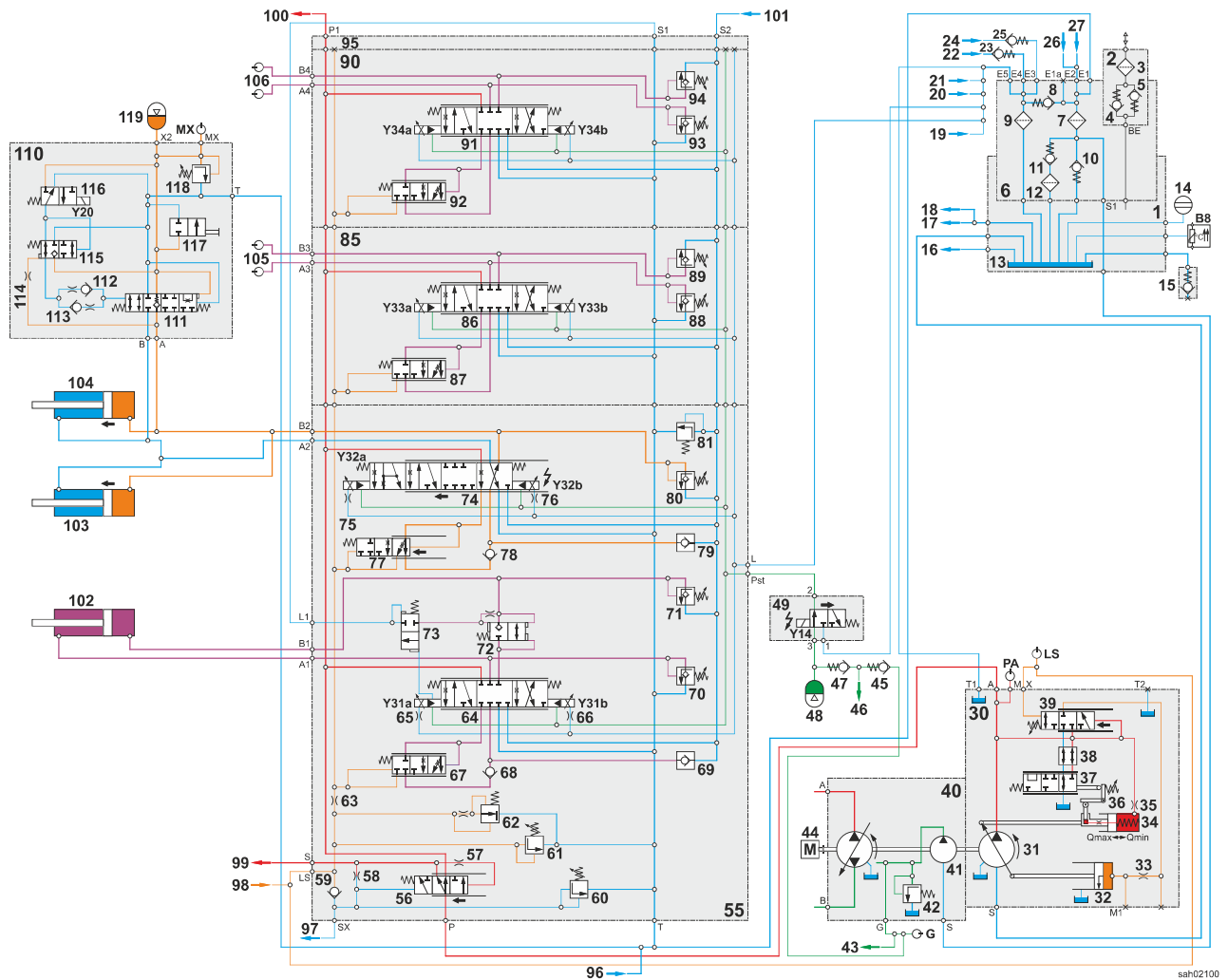

Fig. 365: Diagram of Z-bar kinematics working hydraulics (lift function actuated)

- |    |                              |    |                                    |    |  |
|----|------------------------------|----|------------------------------------|----|--|
| 1  | Hydraulic tank               | 39 | Flow regulator                     | 80 | Secondary pressure relief valve for lifting                  |
| 2  | Breather filter              | 40 | Travel pump                        | 81 | Preload valve for 2nd tank duct                              |
| 3  | Fine filter                  | 41 | Replenishing pump                  | 85 | <b>Control valve block section for 3rd function (option)</b> |
| 4  | Outlet valve 0.65 bar        | 42 | Replenishing pressure relief valve | 86 | Spool valve for 3rd function                                 |
| 5  | Inlet valve 0.03 bar         | 43 | Travel motor bearing flushing      | 87 | Pressure balance for 3rd function                            |
| 6  | <b>Return suction filter</b> | 44 | Diesel engine                      | 88 | Secondary pressure relief valve for 3rd function A3          |
| 7  | Main filter element 10 µm    | 45 | Check valve                        | 89 | Secondary pressure relief valve for 3rd function B3          |
| 8  | Bypass valve 2.5 bar         | 46 | Gear shifting oil supply           | 90 | <b>Control valve block section for 4th function (option)</b> |
| 9  | Return strainer 80 µm        | 47 | Check valve                        | 91 | Spool valve for 4th function                                 |
| 10 | Preload valve 0.5 bar        | 48 | Pilot control hydro accumulator    | 92 | Pressure balance for 4th function                            |

See next page for continuation of the image legend

LBH/12204698/11/21+20190601\_073606/en

**2 Function**

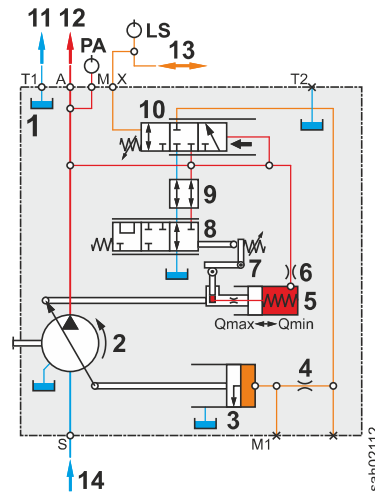

Fig. 370: Hydraulic diagram of the working pump (diesel engine running)

- |                                    |  |
|------------------------------------|--|
| <b>1 Working pump</b>              | <b>8 Power regulator</b>                                   |
| <b>2 Axial piston rotary group</b> | <b>9 Dummy piston</b>                                      |
| <b>3 Return piston</b>             | <b>10 Flow regulator</b>                                   |
| <b>4 Throttle</b>                  | <b>11 Leak oil to return strainer</b>                      |
| <b>5 Positioning piston</b>        | <b>12 Oil supply for control valve block</b>               |
| <b>6 Throttle</b>                  | <b>13 Load sensing signal from the control valve block</b> |
| <b>7 Regulating lever</b>          | <b>14 Suction port from hydraulic tank</b>                 |

Name	Test point	Name	Test point
LS	Load sensing signal for working pump	PA	Working hydraulics high pressure

Tab. 127: Test points

The working pump draws up oil from the hydraulic tank **14** and pumps it to the priority valve in the control valve block **12**.

The working pump supplies oil via the priority valve to the following systems:

- Working hydraulics
- Steering system

The displacement of the working pump depends on the engine speed and swivel plate angle. The working pump is regulated via the load sensing signal from the control valve block **13**.

LBH/12204898/11/21+20190801\_073806/en

- |           |  |           |   |
|-----------|--|-----------|---|
| <b>1</b>  | <b>Control block</b>   | <b>32</b> | Pressure balance for 3rd function   |
| <b>2</b>  | Priority valve   | <b>33</b> | Secondary pressure relief valve for 3rd function A3                           |
| <b>3</b>  | Throttle   | <b>34</b> | Secondary pressure relief valve for 3rd function B3                           |
| <b>4</b>  | Throttle   | <b>35</b> | <b>Control valve block section for 4th function (option)</b>                  |
| <b>5</b>  | Check valve  | <b>36</b> | Spool valve for 4th function  |
| <b>6</b>  | Steering system LS pressure cut-off                          | <b>37</b> | Pressure balance for 4th function   |
| <b>7</b>  | Working hydraulics LS pressure cut-off                       | <b>38</b> | Secondary pressure relief valve for 4th function A4                           |
| <b>8</b>  | Flow regulating valve  | <b>39</b> | Secondary pressure relief valve for 4th function B4                           |
| <b>9</b>  | Throttle 1.8 mm  | <b>40</b> | End section   |
| <b>10</b> | Tilt cylinder spool valve                                    | <b>41</b> | Return flow to return suction filter  |
| <b>11</b> | Throttle 0.6 mm  | <b>42</b> | Return flow from stabilization module (option)                                |
| <b>12</b> | Throttle 0.6 mm  | <b>43</b> | Return flow from valve block for quick coupler (option)                       |
| <b>13</b> | Tilt cylinder pressure balance                               | <b>44</b> | Oil supply from working pump  |
| <b>14</b> | Tilt cylinder load retaining valve                           | <b>45</b> | Load sensing signal from servostat  |
| <b>15</b> | Tilt cylinder replenishing valve                             | <b>46</b> | Load sensing signal for working pump  |
| <b>16</b> | Secondary pressure relief valve for tilting out              | <b>47</b> | Load-sensing signal from valve block for quick coupler (option)               |
| <b>17</b> | Secondary pressure relief valve for tilting in               | <b>48</b> | Oil supply to servostat   |
| <b>18</b> | Low-leak valve   | <b>49</b> | Connection to ring side of tilt cylinder                                      |
| <b>19</b> | Release valve for low-leak valve                             | <b>50</b> | Connection to piston side of tilt cylinder                                    |
| <b>20</b> | Lift cylinder spool valve                                    | <b>51</b> | Connection to ring side of lift cylinder                                      |
| <b>21</b> | Throttle 0.6 mm  | <b>52</b> | Connection to piston side of lift cylinder                                    |
| <b>22</b> | Throttle 0.6 mm  | <b>53</b> | Connection of 3rd function A3 (option)  |
| <b>23</b> | Lift cylinder pressure balance                               | <b>54</b> | Connection of 3rd function B3 (option)  |
| <b>24</b> | Lift cylinder load retaining valve                           | <b>55</b> | Connection of 4th function A4 (option)  |
| <b>25</b> | Lift cylinder replenishing valve                             | <b>56</b> | Connection of 4th function B4 (option)  |
| <b>26</b> | Secondary pressure relief valve for lifting                  | <b>57</b> | Oil supply for valve block for quick coupler (option)                         |
| <b>27</b> | Preload valve for 2nd tank duct                              | <b>58</b> | Return flow from compact brake valve (control valve block housing preheating) |
| <b>30</b> | <b>Control valve block section for 3rd function (option)</b> | <b>59</b> | Return flow to return strainer  |
| <b>31</b> | Spool valve for 3rd function                                 | <b>60</b> | Control oil from the replenishing pump  |

## 060.6 Pilot control

### 060.6.1 Servo pressure solenoid valve

Valid for: L538-1559;

#### 1 Layout

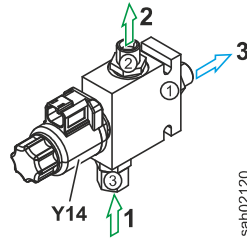

Fig. 381: Solenoid valve for servo pressure (from front left)

- 1 Oil supply from replenishing pump
- 2 Control oil to control valve block
- 3 Return flow to return strainer

BMK	Function
Y14	Solenoid for servo pressure

Tab. 134: Equipment codes

The servo pressure solenoid valve is installed in the frame of the rear section, behind the rear axle.

#### 2 Function

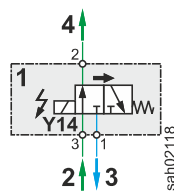

Fig. 382: Hydraulic diagram of solenoid valve for servo pressure (diesel engine is running)

- 1 Servo pressure solenoid valve
- 2 Oil supply from replenishing pump
- 3 Return flow to return strainer
- 4 Control oil to control valve block

BMK	Function
Y14	Solenoid for servo pressure

Tab. 135: Equipment codes

The servo pressure solenoid valve 1 separates the control valve block 4 from the pilot control oil. This means the functions of the control valve block can no longer be performed.

If the bucket position angle sensor **B60** is installed, the bucket return-to-dig sensor **B15** is not needed.

A programmable bucket return-to-dig can be realised with the bucket position angle sensor **B60**.

Programmable lower automation and lift automation can be realised with lift arm position angle sensor **B61**.

### 1.5 Regular calibrations

The following components of working hydraulics must be calibrated regularly according to the adjustment checklist:

- Proportional magnets on the control valve block
- Angle sensor for bucket position (optional)
- Angle sensor for lift arm position (optional)

#### 1.5.1 Stand values for proportional solenoids on control valve block

Lift arm type	Function	Variable	Default value
Z-bar kinematics (L526-1558)	Lifting	<b>CREHLiftUpCurrMoveBegin</b>	930 mA
Z-bar kinematics (L538-1559, L546-1560)			900 mA
Z-bar kinematics	Lowering	<b>CREHLiftDnCurrMoveBegin</b>	650 mA
Z-bar kinematics	Tilting in	<b>CREHBuckUpCurrMoveBegin</b>	940 mA
Z-bar kinematics	Tilting out	<b>CREHBuckDnCurrMoveBegin</b>	950 mA
P-kinematics (L526-1558)	Lifting	<b>CREHLiftUpCurrMoveBegin</b>	930 mA
P-kinematics (L538-1559, L546-1560)			900 mA
P-kinematics	Lowering	<b>CREHLiftDnCurrMoveBegin</b>	650 mA
P-kinematics	Tilting in	<b>CREHBuckUpCurrMoveBegin</b>	940 mA
P-kinematics	Tilting out	<b>CREHBuckDnCurrMoveBegin</b>	880 mA

Tab. 146: Default values

# 070 Travel hydraulics

## Contents

070.1	Overview of travel hydraulics <i>L538-1559;</i>	070-2
070.2	Travel pump <i>L538-1559;</i>	070-7
070.3	Travel motors	070-22
070.3.1	Overview of the travel motors <i>L538-1559;</i>	070-22
070.3.2	Travel motor 1 <i>L538-1559;</i>	070-24
070.3.3	Travel motor 2 <i>L538-1559;</i>	070-32

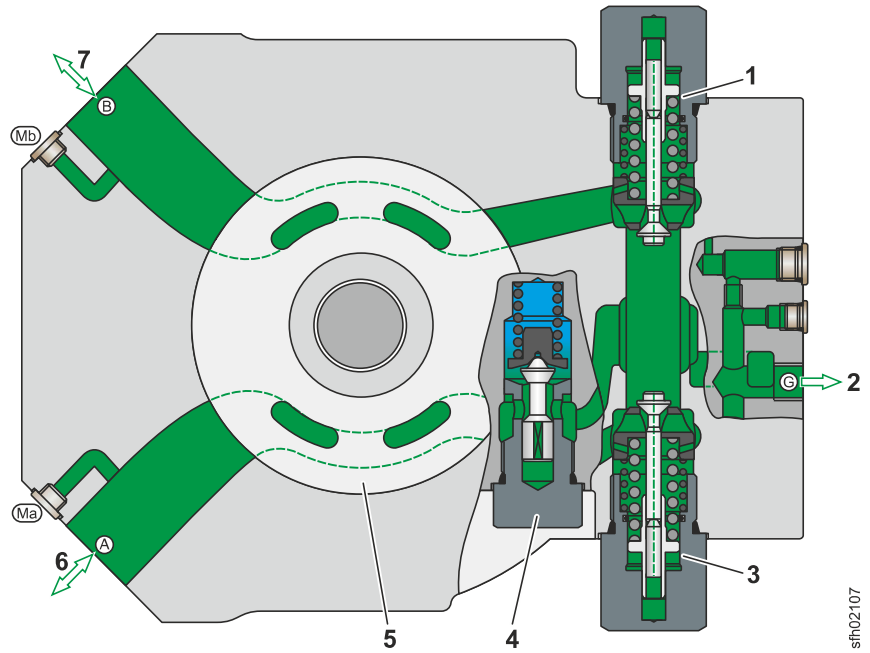

Fig. 402: Replenishing pressure relief valve and high pressure relief valves: sectional view

- |   |   |   |   |
|---|---|---|---|
| 1 | Reverse travel direction high pressure relief valve       | 5 | Control plate   |
| 2 | Oil for pilot control, gear shifting and bearing flushing | 6 | Oil supply for travel motors (forward travel direction high pressure) |
| 3 | Forward travel direction high pressure relief valve       | 7 | Oil supply for travel motors (reverse travel direction high pressure) |
| 4 | Replenishing pressure relief valve                        |   |   |

LBH/12204898/11211-20190801\_073606/en

CLICK HERE TO **DOWNLOAD** THE COMPLETE MANUAL

- Thank you very much for reading the preview of the manual.
- You can download the complete manual from: [www.heydownloads.com](http://www.heydownloads.com) by clicking the link below



- Please note: If there is no response to CLICKING the link, please download this PDF first and then click on it.

CLICK HERE TO **DOWNLOAD** THE COMPLETE MANUAL

When limiting the operating pressure, the high pressure moves the high pressure relief valve **5** against the spring force of high pressure relief compression spring **2**, thus draining oil from the closed circuit **1** into the replenishing pressure duct **6**. The discharged oil is immediately fed back into the closed circuit via the opposing high pressure relief valve.

Because the high-pressure relief valves react faster than the pressure cut-off, they provide initial protection against pressure spikes.

The high pressure pushes the axial piston rotary group to a smaller swivel angle. Output speed and high pressure rise.

If the high pressure exceeds the set value, it moves the servo pressure valve 2 against the spring force of the regulating spring 3. As a result, the servo pressure valve 2 connects the other side of the positioning piston 5 with the high pressure. Due to the larger surface, the high pressure swivels the axial piston rotary group to a larger swivel angle. Output speed and high pressure decrease.

### 2.5 Travel range 1 solenoid

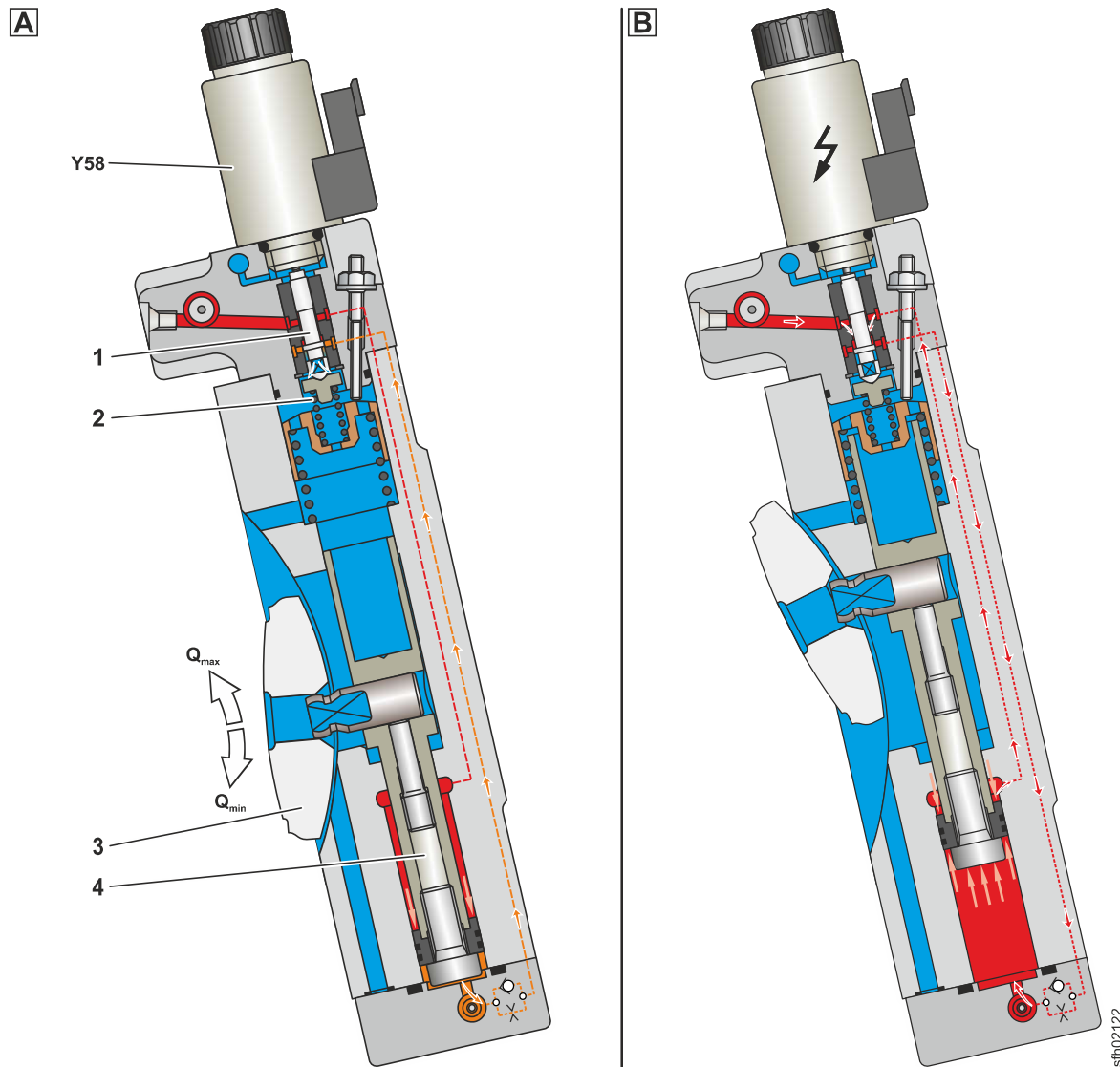

Fig. 420: Travel motor regulates / travel motor in travel range 1

- |   |                             |   |                    |
|---|-----------------------------|---|--------------------|
| 1 | Servo pressure valve        | 3 | Control lens       |
| 2 | Regulating spring for servo | 4 | Positioning piston |
|   | pressure valve              |   |                    |

LBH/12204898/11/21+20190801\_073606/en

sifh02122

# 080 Hydraulic components

## Contents

080.1	Hydraulic system: overview <i>L538-1559;</i>	080-2
080.2	Hydraulic tank	080-6
080.2.1	Overview of the hydraulic tank <i>L538-1559;</i>	080-6
080.2.2	Return suction filter <i>L538-1559;</i>	080-9
080.2.3	Breather filter <i>L538-1559;</i>	080-14

## 2 Function

### 2.1 Basic function

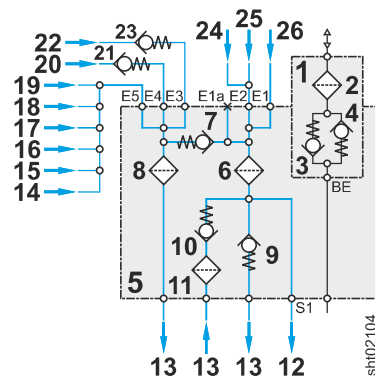

Fig. 433: Return-suction filter: hydraulic diagram

<b>1</b>	<b>Breather filter</b>	<b>14</b>	Fan motor leak oil
<b>2</b>	Fine filter	<b>15</b>	Return flow from pilot control
<b>3</b>	Outlet valve 0.65 bar	<b>16</b>	Return flow from servo pressure solenoid valve
<b>4</b>	Inlet valve 0.03 bar	<b>17</b>	Compact brake valve return flow
<b>5</b>	<b>Return suction filter</b>	<b>18</b>	Return flow from gear shifting proportional solenoid valve
<b>6</b>	Main filter element 10 µm	<b>19</b>	Working pump leak oil
<b>7</b>	Bypass valve 2.5 bar	<b>20</b>	Return flow from servostat
<b>8</b>	Return strainer 80 µm	<b>21</b>	Preload valve 9 bar
<b>9</b>	Preload valve 0.5 bar	<b>22</b>	Bypass for travel pump leak oil
<b>10</b>	Replenishing valve 0.05 bar	<b>23</b>	Bypass valve 2.5 bar
<b>11</b>	Strainer 160 µm	<b>24</b>	Return flow from oil cooler
<b>12</b>	Replenishing pump suction port	<b>25</b>	Bypass of the oil cooler
<b>13</b>	Steel tank	<b>26</b>	Return flow from control valve block

The oil returning from the hydraulic components is collected and filtered in the return-suction filter. The oil then flows into the steel tank 13.

### 2.2 Return strainer

In the return strainer, impurities with a minimum size of 80 µm are filtered out of the oil.

2 Function

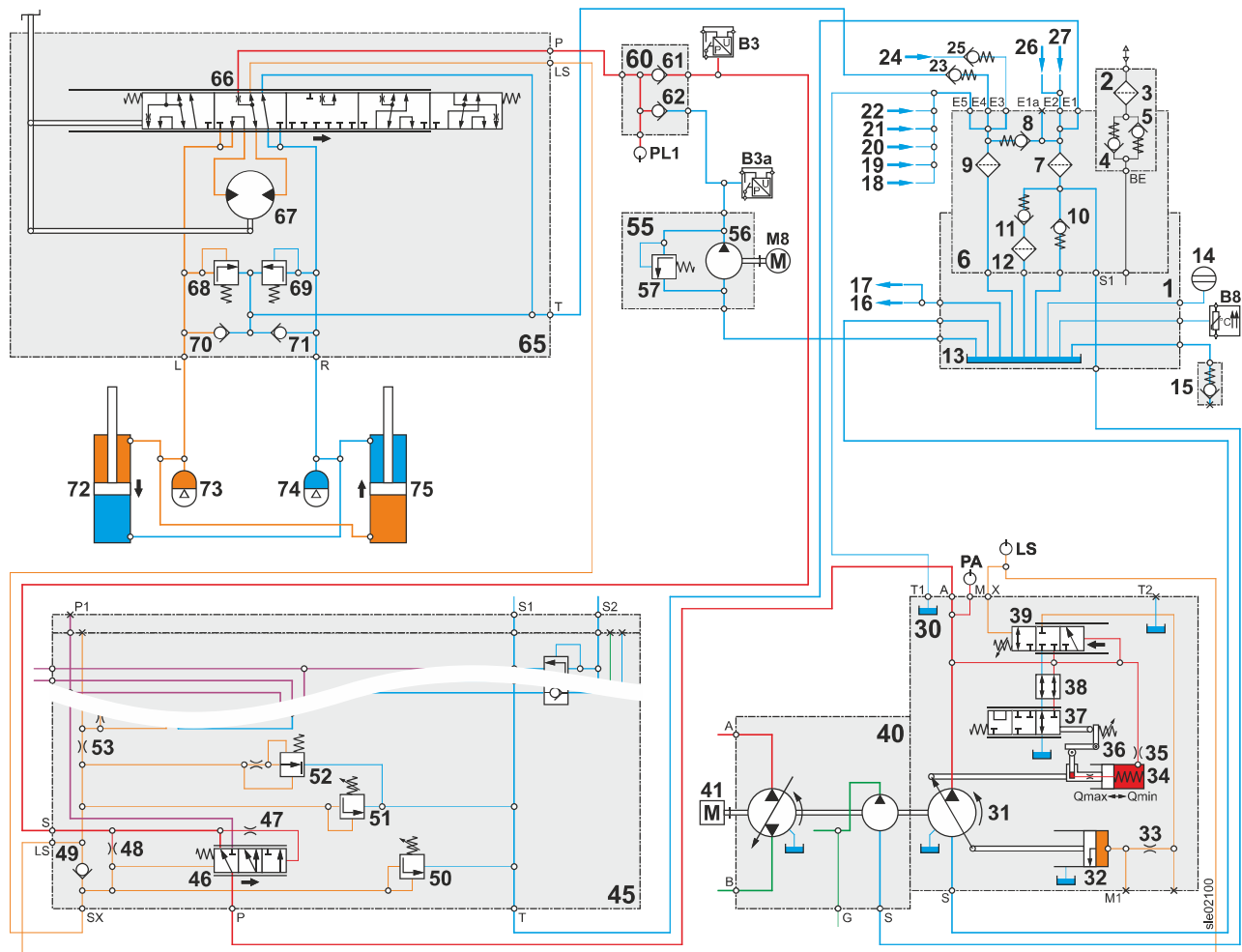

Fig. 443: Hydraulic diagram of the steering system (steering to the left)

- |    |                                     |    |                                       |    |  |
|----|-------------------------------------|----|---------------------------------------|----|--|
| 1  | <b>Hydraulic tank</b>               | 23 | Preload valve 9 bar                   | 50 | Steering system LS pressure cut-off                      |
| 2  | <b>Breather filter</b>              | 24 | Bypass for travel pump leak oil       | 51 | Working hydraulics LS pressure cut-off                   |
| 3  | Fine filter                         | 25 | Bypass valve 2.5 bar                  | 52 | Flow regulating valve                                    |
| 4  | Outlet valve 0.65 bar               | 26 | Return flow from hydraulic oil cooler | 53 | Throttle 1.8 mm  |
| 5  | Inlet valve 0.03 bar                | 27 | Hydraulic oil cooler bypass           | 55 | <b>Emergency steering pump</b>                           |
| 6  | <b>Return suction filter</b>        | 30 | <b>Working pump</b>                   | 56 | Gear pump  |
| 7  | Main filter element 10 µm           | 31 | Axial piston rotary group             | 57 | Pressure relief valve                                    |
| 8  | Bypass valve 2.5 bar                | 32 | Return piston                         | 60 | <b>Valve block for steering system</b>                   |
| 9  | Return strainer 80 µm               | 33 | Throttle                              | 61 | Check valve  |
| 10 | Preload valve 0.5 bar               | 34 | Positioning piston                    | 62 | Check valve  |
| 11 | Replenishing valve 0.05 bar         | 35 | Throttle                              | 65 | <b>Servostat</b>   |
| 12 | Strainer 160 µm                     | 36 | Regulating lever                      | 66 | Valve spool  |
| 13 | Steel tank                          | 37 | Power regulator                       | 67 | Metering pump  |
| 14 | Sight glass for hydraulic oil level | 38 | Dummy piston                          | 68 | Secondary pressure relief valve for steering to the left |

See next page for continuation of the image legend

The emergency steering pump power relay **K11** is fitted on the right of the rear section.

The emergency steering control relay **K14** and the emergency steering relay **K16** are installed on the fuse board A4.

The *on-road travel* switch **S19** is fitted in the top right of the operator's cab. This switch is optional.

**2.1 Basic function**

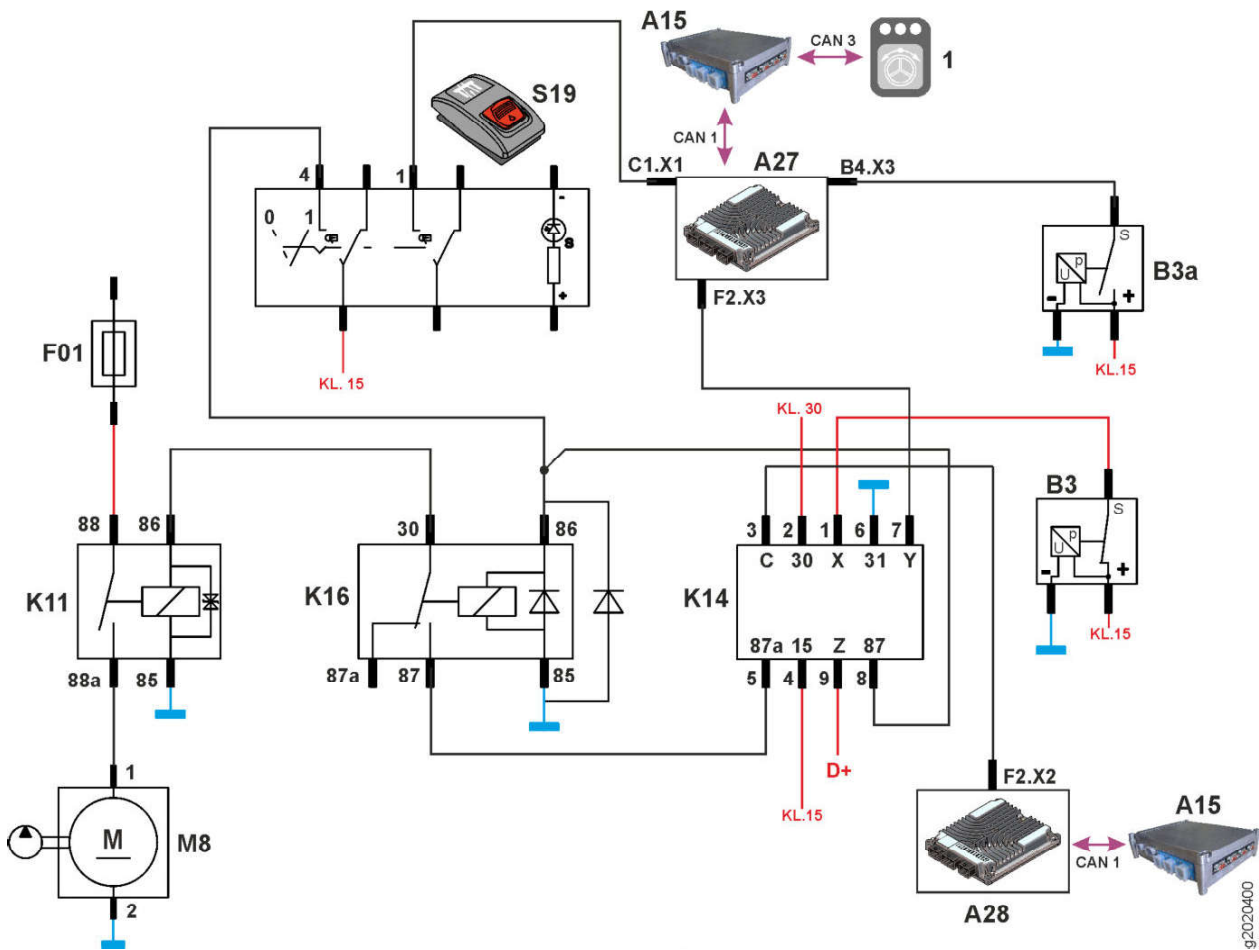

Fig. 455: Electric control when the diesel engine is running and steering pressure is present

LBH/12204898/11/21+20190801\_073606/en

Position	Function	Position	Function
1	Emergency steering function key	F01	Emergency steering pump fuse (200 A)
A15	Central control unit (Master4)	K11	Emergency steering pump power relay
A27	Compact module	K14	Emergency steering pump control relay
A28	Compact module	K16	Emergency steering relay
B3	Emergency steering pressure switch (shown actuated)	M8	Emergency steering pump
B3a	Emergency steering check pressure switch	S19	On-road travel switch

Tab. 207: Designations

Two shuttle valves ensure that the priority valve and working pump are always supplied with the load sensing signal of relevant active system.

### 2.3 Pressure protection

When using joystick steering, pressure protection is also performed by the secondary pressure relief valves in the servostat **80** and the LS pressure cut-off for the steering system **50** in the control valve block **45**.

## 090.4.2 Overview of joystick steering

Valid for: L538-1559/44505-53763;

This equipment is optional.

### 1 Layout

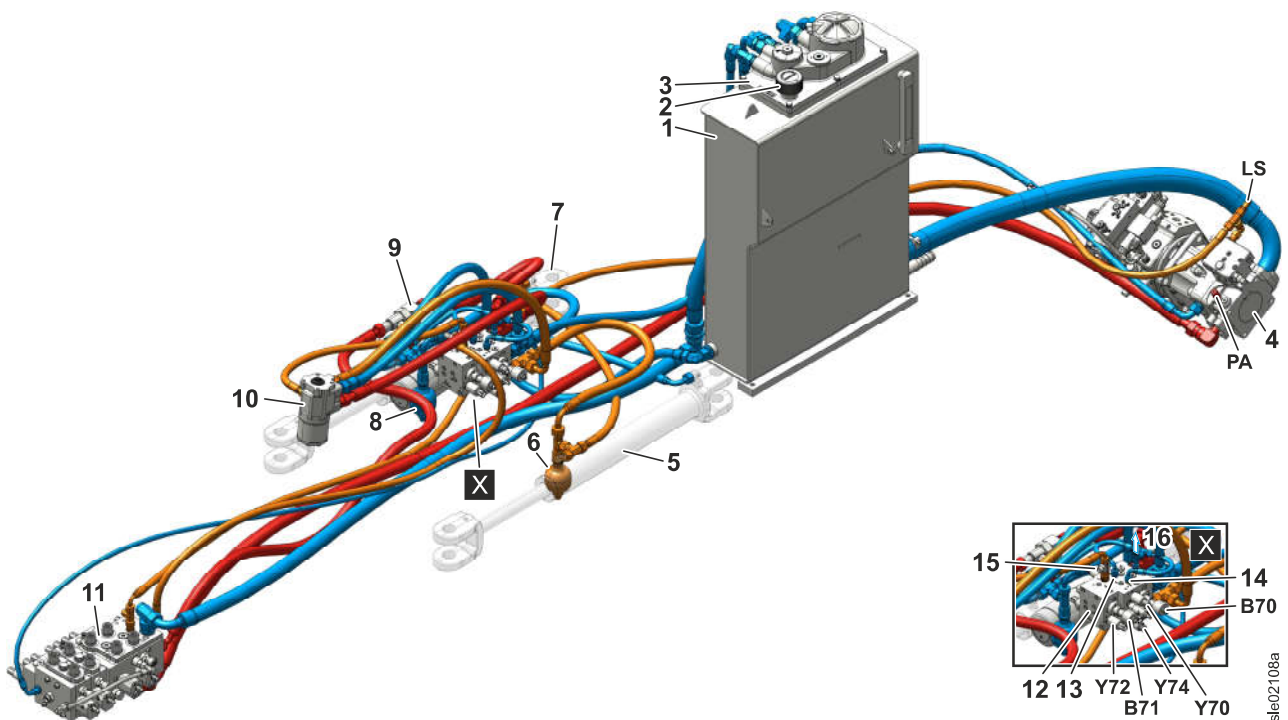

Fig. 462: Joystick steering system (steering to left) (from front left)

- |  |  |  |
|--|--|--|
| <p>1 Hydraulic tank</p> <p>2 Breather filter</p> <p>3 Return suction filter</p> <p>4 Working pump</p> <p>5 Left steering cylinder</p> <p>6 Steering damper hydro accumulator</p> | <p>7 Right steering cylinder</p> <p>8 Steering damper hydro accumulator</p> <p>9 Valve block for steering system</p> <p>10 Servostat</p> <p>11 Control block</p> <p>12 Joystick steering control valve block</p> | <p>13 Orifice 0.8 mm</p> <p>14 Orifice 0.8 mm</p> <p>15 Shuttle valve</p> <p>16 Return flow to the return suction filter (via compact brake valve)</p> |
|--|--|--|

LBH/12204898/11/21+20190801\_073606/en

sle02108a

Name	Test point	Name	Test point	Name	Test point
<b>M B1</b>	Servo pressure for steering to the right (main spool valve) <sup>A)</sup>	<b>M B2</b>	Servo pressure for steering to the right (emergency spool valve) <sup>A)</sup>		

Tab. 219: Test points

A) Thread M10x1

BMK	Function	BMK	Function	BMK	Function
<b>B70</b>	Main spool valve position sensor	<b>Y71</b>	Proportional solenoid for steering to the left (spool valve for emergency steering function)	<b>Y74</b>	Solenoid for safety circuit
<b>B71</b>	Emergency spool valve position sensor	<b>Y72</b>	Proportional solenoid for steering to the left (emergency spool valve)		
<b>Y70</b>	Proportional solenoid for steering to the left (main spool valve)	<b>Y73</b>	Proportional solenoid for steering to the right (emergency spool valve)		

Tab. 220: Equipment codes

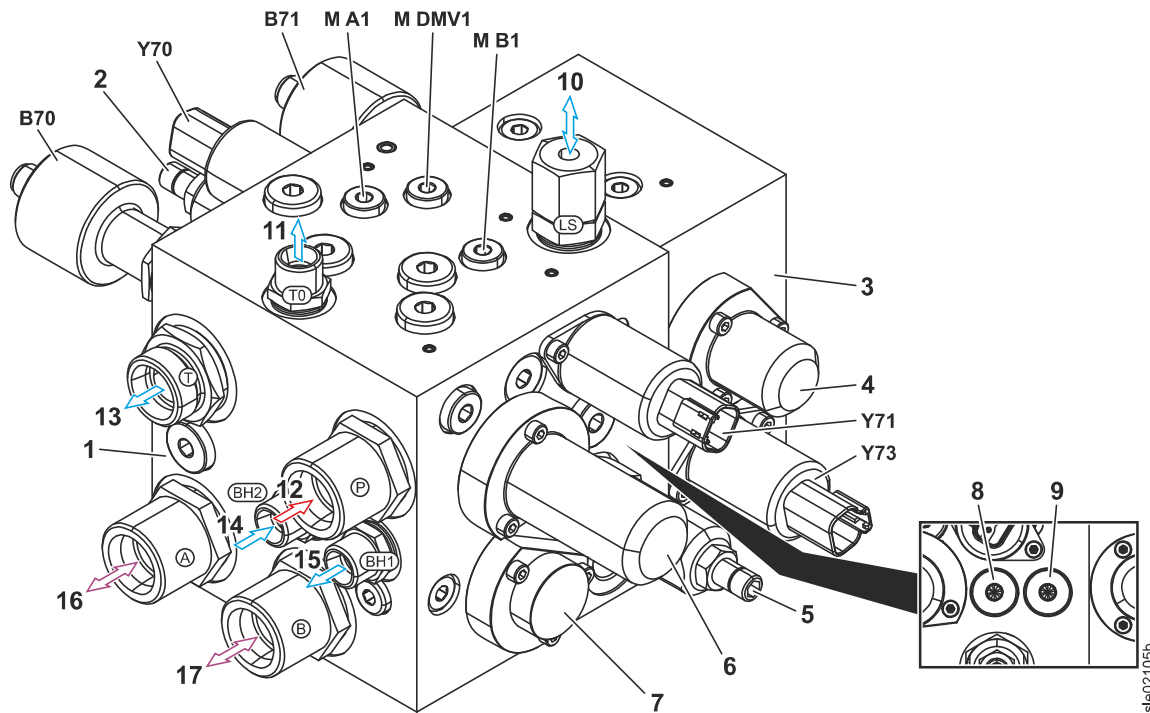

Fig. 467: Control valve block for joystick steering (from rear right)

- |   |   |   |
|---|---|---|
| <b>1</b> Joystick steering control valve block              | <b>7</b> Cut-off valve for main spool valve           | <b>13</b> Return flow to return strainer                            |
| <b>2</b> Servo pressure reducing valve for main spool valve | <b>8</b> Servo oil strainer for emergency spool valve | <b>14</b> Return flow from compact brake valve (housing preheating) |

See next page for continuation of the image legend

LBH/12204898/11/21+20190801\_073806/en

A) Thread M10x1

BMK	Function	BMK	Function	BMK	Function
B70	Main spool valve position sensor	Y71	Proportional solenoid for steering to the left (spool valve for emergency steering function)	Y74	Solenoid for safety circuit
B71	Emergency spool valve position sensor	Y72	Proportional solenoid for steering to the left (emergency spool valve)		
Y70	Proportional solenoid for steering to the left (main spool valve)	Y73	Proportional solenoid for steering to the right (emergency spool valve)		

Tab. 232: Equipment codes

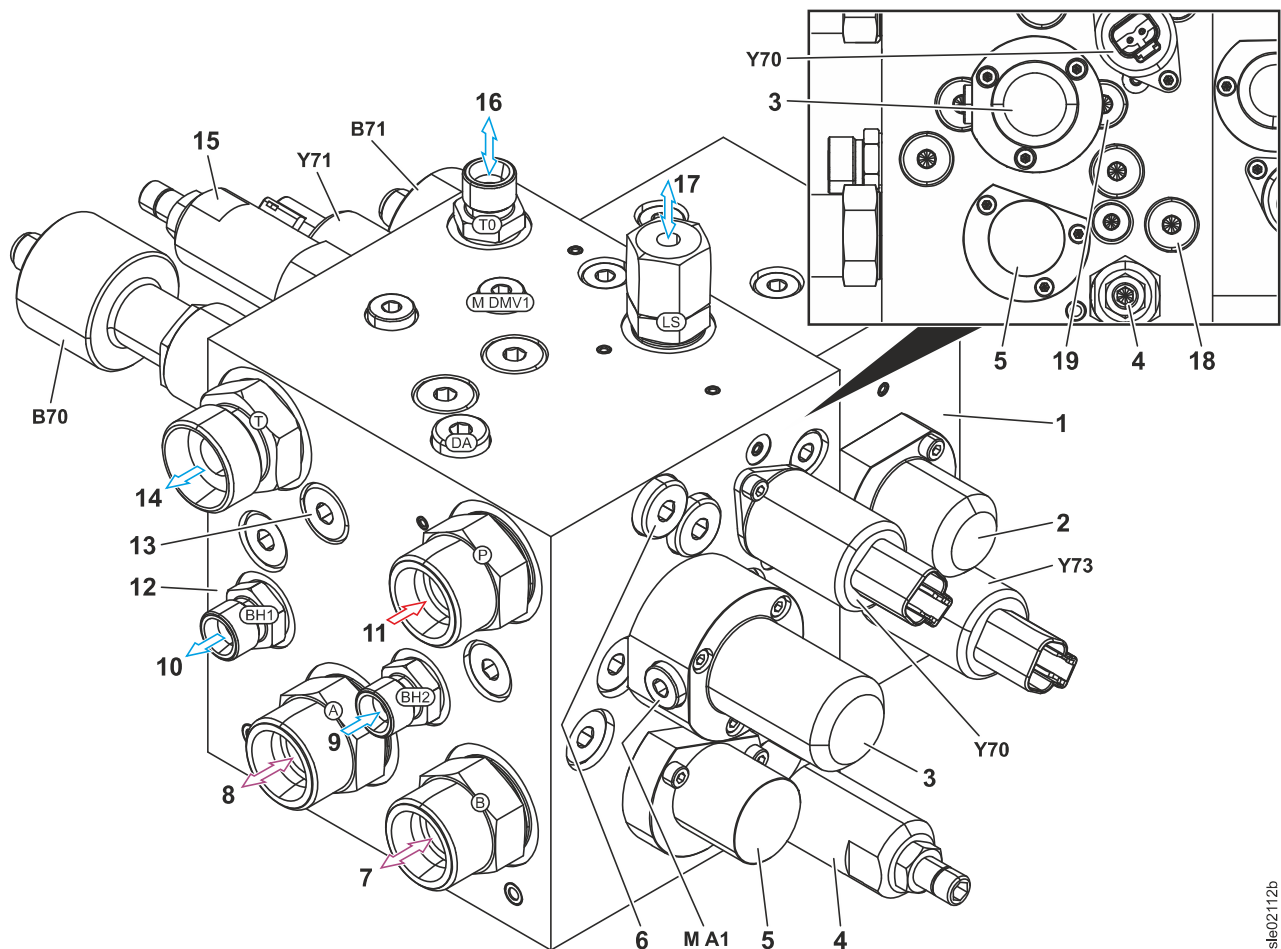

Fig. 473: Control valve block for joystick steering (from rear right)

- |   |   |   |   |    |  |
|---|---|---|---|----|--|
| 1 | Control block section for emergency steering function | 8 | Connection for steering to left                           | 15 | Pressure reducing valve for main spool valve                       |
| 2 | Emergency spool valve                                 | 9 | Return flow from compact brake valve (housing preheating) | 16 | Return flow to the return suction filter (via compact brake valve) |

See next page for continuation of the image legend

LBH/12204698/11/21+20190801\_073606/en

sle02112b

Position	Component	Position	Component
K4	Selector relay for function test of emergency steering circuit and latching activation	7b	Gerotor steering relay (optional)
K5a	Emergency mode solenoid valve relay		

Tab. 240: Components

The relay **K1** powers the joystick steering via terminal 15.

The joystick steering functions are powered via the fuses **F**.

The analogue outputs of emergency steering valves on joystick module A29 are powered by relay **K3** and relay **K2**. Relay **K2** is activated by relay **K4**. Relay **K2** remains activated by means of a self latching circuit if there is no signal from relay **K4**.

Relay **K4** has several functions. When the joystick steering is switched on, the function of emergency steering circuit is tested. Power is supplied for this to the analogue outputs for the emergency steering valves via relay **K4** and the compact module A28.

If the functional test of emergency steering circuit has been successfully completed, the relay **K4** is energized again for a short period. This activates the latching via the relay **K2**.

If the functional test was not successful, the power supply for the analogue outputs of emergency steering valves is switched off via compact module A28. A service code is displayed.

Relays **K6a** and **K6b** ensure that the analogue outputs for the emergency steering valves are not supplied with voltage when the on-road travel switch S19b is active. If on-road travel switch S19b is activated **after** the joystick steering has been switched on, the power supply remains for the analogue outputs of emergency steering valves via relays **K2** and **K3**.

Relays **K5a** and **K5b** interrupt the power supply for the solenoid valve for emergency mode Y74 if the on-road travel switch S19b is activated. The circuit has two relays for safety reasons.

<b>16</b>	Fan pump suction port	<b>45</b>	<b>Control block</b>	<b>71</b>	Replenishing valve for steering to left
<b>17</b>	Brake pump suction port	<b>46</b>	Priority valve	<b>72</b>	Replenishing valve for steering to the right
<b>18</b>	Fan motor leak oil	<b>47</b>	Throttle	<b>73</b>	Left steering cylinder
<b>19</b>	Return flow from pilot control	<b>48</b>	Throttle	<b>74</b>	Steering damper hydro accumulator
<b>20</b>	Return flow from servo pressure solenoid valve	<b>49</b>	Check valve	<b>75</b>	Steering damper hydro accumulator
<b>21</b>	Return flow from clutch proportional solenoid	<b>50</b>	Steering system LS pressure cut-off	<b>76</b>	Right steering cylinder
<b>22</b>	Preload valve 9 bar	<b>51</b>	Working hydraulics LS pressure cut-off		
<b>23</b>	Bypass for travel pump leak oil	<b>52</b>	Flow regulating valve		

Name	Test point	Name	Test point	Name	Test point
<b>LS</b>	Load sensing signal for working pump	<b>PA</b>	Working pump high pressure	<b>PL1</b>	High pressure for steering pump or emergency steering pump

Tab. 245: Test points

BMK	Function	BMK	Function	BMK	Function
<b>B3</b>	Emergency steering pressure switch	<b>B8</b>	Hydraulic oil temperature sensor	<b>Y63</b>	Solenoid for 2in1 steering
<b>B3a</b>	Emergency steering check pressure switch	<b>M8</b>	Electric motor for emergency steering pump		

Tab. 246: Equipment codes

## 090.5.2 Servostat for 2in1 steering

Valid for: L538-1559;

### 1 Layout

Servostat for 2in1 steering is bolted underneath cab floor.

BMK	Function	BMK	Function
B19	Brake accumulator pressure sensor	Y10	Parking brake solenoid

Tab. 254: Equipment codes

The compact brake valve is screw-connected to the floor of the operator's cab.

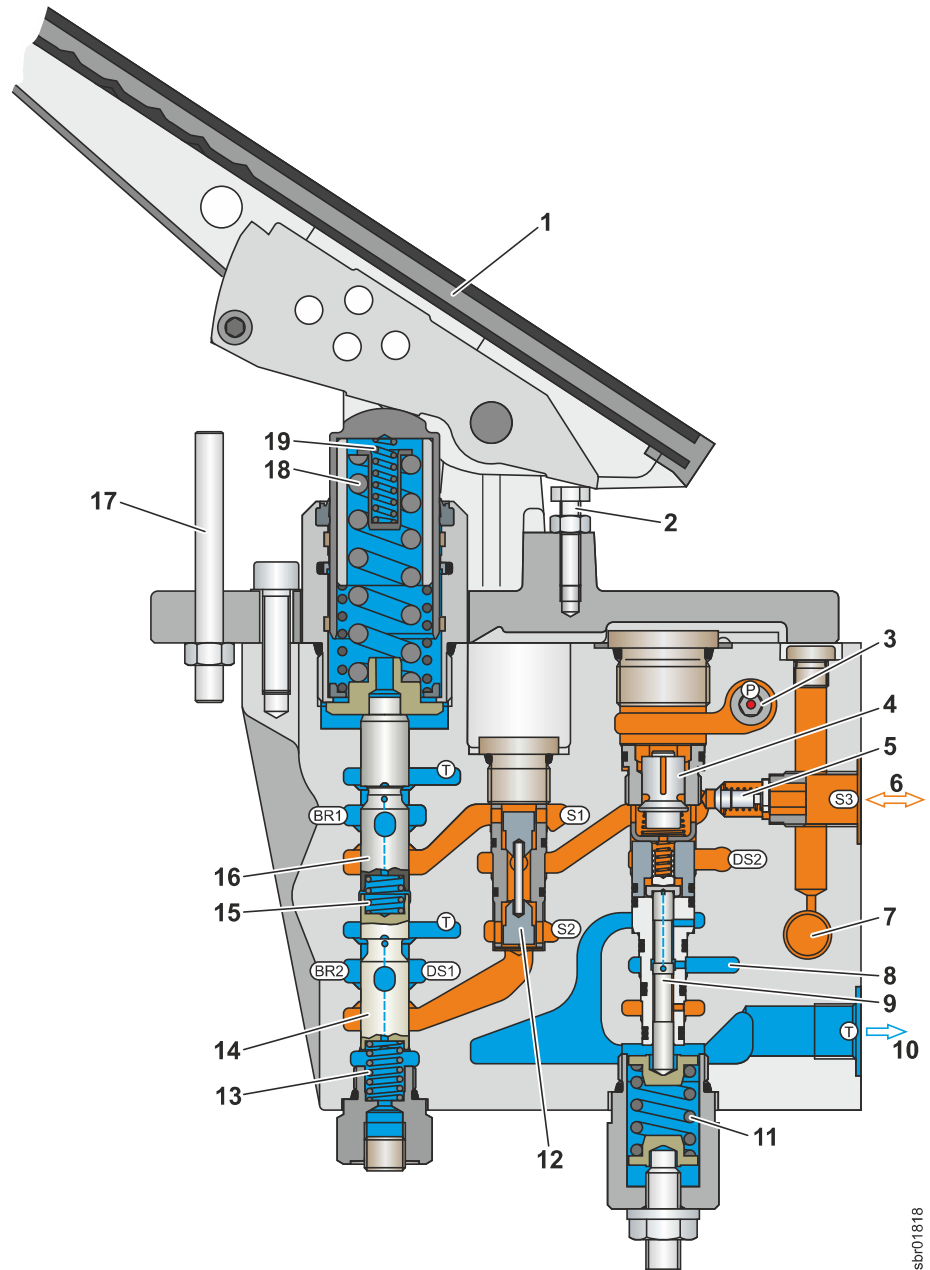

Fig. 491: Sectional view of the compact brake valve

- |   |                          |    |  |
|---|--------------------------|----|--|
| 1 | Inching brake pedal      | 11 | Regulating spring for pilot valve            |
| 2 | Zero position stop screw | 12 | Inverted shuttle valve                       |
| 3 | Inlet restrictor         | 13 | Return spring for pressure regulation piston |

See next page for continuation of the image legend

LBH/12204898/1121+20190801\_073806/en

sbr01818

# 110 Electrical system

## Contents

110.1	Overview of the electrical system <i>L538-1559;</i>	110-2
110.2	Lighting <i>L538-1559;</i>	110-6
110.3	Circuit diagrams <i>L538-1559;</i>	110-8
110.4	Electronic control unit	110-10
110.4.1	General overview of the electronic control system <i>L538-1559;</i>	110-10
110.4.2	Central control unit (Master4) <i>L538-1559;</i>	110-12
110.4.3	Modules	110-16
110.4.3.1	General overview of the compact modules <i>L538-1559;</i>	110-16
110.4.3.2	Compact module <i>L538-1559;</i>	110-18
110.5	Electrical components of the driver's cab	110-24
110.5.1	Fuse and relay boards <i>L538-1559;</i>	110-24
110.5.2	Door contact switch <i>L538-1559;</i>	110-28
110.6	Electrical components in the rear section	110-29
110.6.1	Battery installation <i>L538-1559;</i>	110-29
110.7	Rear area monitoring with camera	110-31
110.7.1	Overview of rear area monitoring with camera <i>L538-1559;</i>	110-31
110.7.2	Camera <i>L538-1559;</i>	110-32

PROJECT: L524-L546\_StufeIV\_7\_Serie  
 DRAWING NUMBER: 1560 00190 01 00  
 DRAWING INDEX: 000  
 ARTICLE CODE: 12412113

ISO 19016: The reproduction, distribution and utilization of this document as well as the communication of its contents to others without express authorization is prohibited. Offenders will be held liable for the payment of damages. All rights reserved in the event of the grant of a patent, utility model or design.

TABLE OF CONTENTS	SHEET
SELECTION INDICATOR E PLAN	/23
WORKING PROJECTOR REAR E PLAN	/26
WORKING PROJECTOR FRONT E PLAN	/25
OUTLETS TRAVEL DRIVE E PLAN	/35
BATTERY : MASTER SWITCH : ENGINE START E PLAN	/20
LIGHTING E PLAN	/22
WORKING HOUR METER E PLAN	/21
BLOCK DIAGRAM STANDARD E PLAN	/1
BMK-INDEX E PLAN	/5
BMK-INDEX E PLAN	/6
BMK-INDEX E PLAN	/7
BMK-INDEX E PLAN	/8
BMK-INDEX E PLAN	/9
BMK-INDEX E PLAN	/10
BMK-INDEX E PLAN	/11
BMK-INDEX E PLAN	/12
BMK-INDEX E PLAN	/13
BMK-INDEX E PLAN	/14
BMK-INDEX E PLAN	/15
BMK-INDEX E PLAN	/16
BMK-INDEX E PLAN	/17
BMK-INDEX E PLAN	/18
INPUTS RESERVE E PLAN	/46
TRAVEL RANGE E PLAN	/34
SPEED-PEDAL - INCH PEDAL E PLAN	/33
GENERATOR	/21
REAR WINDOW HEATER MIRROR HEATING E PLAN	/31
HEAT AIR CONDITIONING SYSTEM E PLAN	/111
HEAT AIR CONDITIONING SYSTEM E PLAN	/112
HEAT AIR CONDITIONING SYSTEM E PLAN	/113
HEAT AIR CONDITIONING SYSTEM E PLAN	/114
HEAT AIR CONDITIONING SYSTEM E PLAN	/115
HEAT AIR CONDITIONING SYSTEM E PLAN	/116
HEAT AIR CONDITIONING SYSTEM E PLAN	/117
HEAT AIR CONDITIONING SYSTEM E PLAN	/118
HEAT AIR CONDITIONING SYSTEM E PLAN	/119

TABLE OF CONTENTS	SHEET
INDUCTIVE SWITCH LIFT ARM E PLAN	/40
INDOOR LIGHTING RADIO DRIVER'S SEAT E PLAN	/30
NUMBER PLATE LIGHT PROFILE LIGHTS E PLAN	/24
KEY E PLAN	/4
MULTI-LEVER CONTROL E PLAN	/99
MULTI-LEVER CONTROL E PLAN	/100
MULTI-LEVER CONTROL E PLAN	/101
MULTI-LEVER CONTROL E PLAN	/102
MULTI-LEVER CONTROL E PLAN	/103
MULTI-LEVER CONTROL E PLAN	/104
MULTI-LEVER CONTROL E PLAN	/105
MULTI-LEVER CONTROL E PLAN	/106
MULTI-LEVER CONTROL E PLAN	/107
MULTI-LEVER CONTROL E PLAN	/108
MULTI-LEVER CONTROL E PLAN	/109
MULTI-LEVER CONTROL E PLAN	/110
ENGINE ENVIRONMENT E PLAN	/124
ENGINE ENVIRONMENT E PLAN	/125
ENGINE ENVIRONMENT E PLAN	/126
ENGINE ENVIRONMENT E PLAN	/127
ENGINE ENVIRONMENT E PLAN	/128
EMERGENCY STEERING PUMP CONTROL E PLAN	/41
OPTION 2IN1 STEERING E PLAN	/83
OPTION WORKING BASKET E PLAN	/80
OPTION REFUELLING PUMP E PLAN	/88
OPTION FUEL PREHEATING E PLAN	/87
OPTION DIFFERENTIAL LOCK E PLAN	/68
OPTION ANGLE SENSOR LIFT ARM E PLAN	/64
OPTION HORN E PLAN	/71
OPTION JOYSTICK STEERING E PLAN	/90
OPTION JOYSTICK STEERING E PLAN	/91
OPTION JOYSTICK STEERING E PLAN	/92
OPTION JOYSTICK STEERING E PLAN	/93
OPTION JOYSTICK STEERING E PLAN	/94
OPTION JOYSTICK STEERING E PLAN	/95
OPTION JOYSTICK STEERING E PLAN	/96

BMK	SYSTEM	PLACE	FUNCTION	SYSTEM	PLACE	FUNCTION	SHEET
-M9.X	=H	+H4	PLUG WASHING PUMP REAR	=K	+K2	MASS GROUPING BLOCK	/29.E6
-M11	=K	+K4	WATER VALVE HEAT AIR CONDITIONING SYSTEM	=K	+K2	MASS GROUPING BLOCK	/116.E3
-M11.X	=K	+K4	PLUG WATER VALVE	=K	+K2	MASS GROUPING BLOCK	/116.E2
-M14	=K	+K4	RECIRCULATED AIR FLAP HEAT AIR CONDITIONING SYSTEM	=K	+K2	MASS GROUPING BLOCK	/116.E7
-M14.X	=K	+K4	PLUG RECIRCULATED AIR FLAP	=K	+K2	MASS GROUPING BLOCK	/116.E6
-M15	=K	+K4	FOOT FLAP HEAT AIR CONDITIONING SYSTEM	=K	+K2	MASS GROUPING BLOCK	/117.E3
-M15.X	=K	+K4	PLUG FOOT FLAP	=K	+K2	MASS GROUPING BLOCK	/117.D2
-M16	=K	+K4	MIDDLE FLAP HEAT AIR CONDITIONING SYSTEM	=K	+K2	MASS GROUPING BLOCK	/117.E7
-M16.X	=K	+K4	PLUG MIDDLE FLAP	=K	+K3	MASS GROUPING BLOCK	/117.D6
-M17	=K	+K4	HEAD FLAP HEAT AIR CONDITIONING SYSTEM	=K	+K3	MASS GROUPING BLOCK	/118.E3
-M17.X	=K	+K4	PLUG HEAD FLAP	=K	+K3	MASS GROUPING BLOCK	/118.E3
-M200	=K	+K4	DUST FILTER EXCESS PRESSURE SYSTEM	=K	+K	CONNECTION QUICK-CHANGE DEVICE	/70.E5
-M500	=K	+K2	REFUELLING PUMP	=K	+K1	WORKING HOUR METER	/88.E7
-M500.X	=K	+K2	PLUG REFUELLING PUMP	=K	+K1	PLUG WORKING HOUR METER	/88.E7
-MP1_a	=H	+H2	MASS GROUPING BLOCK	=K	+K4	PLUG WORKING HOUR METER	/112.F3
-MP1_b	=H	+H2	MASS GROUPING BLOCK	=K	+K4	PLUG WORKING HOUR METER	/22.F6
-MP1_c	=H	+H4	MASS GROUPING BLOCK	=K	+K1	PLUG WORKING HOUR METER	/20.F7
-MP1_h	=H	+H2	MASS GROUPING BLOCK	=K	+K6	INCH PEDAL	/19.F1
-MP2_a	=H	+H6	MASS GROUPING BLOCK	=K	+K6	PLUG INCH PEDAL	/36.F6
-MP2_b	=H	+H6	MASS GROUPING BLOCK	=K	+K6	SPEED-PEDAL	/37.F1
-MP2_c	=H	+H6	MASS GROUPING BLOCK	=K	+K6	PLUG SPEED-PEDAL	/54.B5
-MP2_d	=H	+H6	MASS GROUPING BLOCK	=K	+K3	MIRROR HEATING LEFT	/36.F3
-MP2_e	=H	+H6	MASS GROUPING BLOCK	=K	+K3	PLUG MIRROR HEATING LEFT	/41.E5
-MP2_f	=H	+H6	MASS GROUPING BLOCK	=K	+K3	MIRROR HEATING RIGHT	/85.A3
-MP2_g	=H	+H6	MASS GROUPING BLOCK	=K	+K3	PLUG MIRROR HEATING RIGHT	/98.F2
-MP2_h	=H	+H6	MASS GROUPING BLOCK	=A4	+K2	EXCITATION 100 OHM	/80.F5
-MP4_c	=H	+H2	MASS GROUPING BLOCK	=A4	+K2	EXCITATION 220 OHM	/19.E2
-MP4_d	=H	+H2	MASS GROUPING BLOCK	=M	+M	FUEL PREHEATING	/54.E5
-MP4_e	=H	+H2	MASS GROUPING BLOCK	=M	+M	PLUG FUEL PREHEATING	/19.E1
-MP5_a	=H	+H4	MASS GROUPING BLOCK	=K	+K3	REAR WINDOW HEATER	/41.F1
-MP6_a	=H	+H6	MASS GROUPING BLOCK	=K	+K3	PLUG REAR WINDOW HEATER	/20.E3
-MP6_a	=K	+K2	MASS GROUPING BLOCK	=K	+K3	PLUG REAR WINDOW HEATER	/19.F2
-MP6_b	=K	+K2	MASS GROUPING BLOCK	=A4	+K2	DROP RESISTOR	/21.F7
-MP6_c	=K	+K2	MASS GROUPING BLOCK	=K	+K	MATCHING RESISTOR	/52.B2
-MP6_d	=K	+K2	MASS GROUPING BLOCK	=K	+K	MATCHING RESISTOR	/31.C6
-MP6_e	=K	+K2	MASS GROUPING BLOCK	=K	+K4	CAN END	/19.F2

BMK	SYSTEM	PLACE	FUNCTION	SYSTEM	PLACE	FUNCTION	SHEET
-MP6_f	=K	+K2	MASS GROUPING BLOCK	=K	+K2	MASS GROUPING BLOCK	/43.D5
-MP6_h	=K	+K2	MASS GROUPING BLOCK	=K	+K2	MASS GROUPING BLOCK	/68.D4
-MP6_m	=K	+K2	MASS GROUPING BLOCK	=K	+K2	MASS GROUPING BLOCK	/72.B2
-MP6_l	=K	+K2	MASS GROUPING BLOCK	=K	+K2	MASS GROUPING BLOCK	/79.E5
-MP6_w	=K	+K2	MASS GROUPING BLOCK	=K	+K2	MASS GROUPING BLOCK	/49.D1
-MP6_x	=K	+K2	MASS GROUPING BLOCK	=K	+K2	MASS GROUPING BLOCK	/84.D3
-MP6_y	=K	+K2	MASS GROUPING BLOCK	=K	+K2	MASS GROUPING BLOCK	/87.E6
-MP6_z	=K	+K2	MASS GROUPING BLOCK	=K	+K2	MASS GROUPING BLOCK	/88.D4
-MP7_a	=K	+K3	MASS GROUPING BLOCK	=K	+K3	MASS GROUPING BLOCK	/24.F4
-MP7_b	=K	+K3	MASS GROUPING BLOCK	=K	+K3	MASS GROUPING BLOCK	/30.F7
-MP_ANTENNA	=K	+K3	MASS GROUPING BLOCK ANTENNA	=K	+K3	MASS GROUPING BLOCK ANTENNA	/30.F5
-OLE	=K	+K	CONNECTION QUICK-CHANGE DEVICE	=K	+K	CONNECTION QUICK-CHANGE DEVICE	/84.A2
-P1	=K	+K1	WORKING HOUR METER	=K	+K1	WORKING HOUR METER	/21.E7
-P1.X1	=K	+K1	PLUG WORKING HOUR METER	=K	+K1	PLUG WORKING HOUR METER	/21.E7
-P1.X1.B	=K	+K4	PLUG WORKING HOUR METER	=K	+K4	PLUG WORKING HOUR METER	/74.E4
-P1.X1.S	=K	+K4	PLUG WORKING HOUR METER	=K	+K4	PLUG WORKING HOUR METER	/74.E4
-P1.X2	=K	+K1	PLUG WORKING HOUR METER	=K	+K1	PLUG WORKING HOUR METER	/21.E7
-R1	=K	+K6	INCH PEDAL	=K	+K6	INCH PEDAL	/33.C3
-R1.X	=K	+K6	PLUG INCH PEDAL	=K	+K6	PLUG INCH PEDAL	/33.C3
-R5	=K	+K6	SPEED-PEDAL	=K	+K6	SPEED-PEDAL	/33.C7
-R5.X	=K	+K6	PLUG SPEED-PEDAL	=K	+K6	PLUG SPEED-PEDAL	/33.C6
-R6a	=K	+K3	MIRROR HEATING LEFT	=K	+K3	MIRROR HEATING LEFT	/31.D3
-R6a.X	=K	+K3	PLUG MIRROR HEATING LEFT	=K	+K3	PLUG MIRROR HEATING LEFT	/31.D3
-R6b	=K	+K3	MIRROR HEATING RIGHT	=K	+K3	MIRROR HEATING RIGHT	/31.D4
-R6b.X	=K	+K3	PLUG MIRROR HEATING RIGHT	=K	+K3	PLUG MIRROR HEATING RIGHT	/31.D4
-R9a	=A4	+K2	EXCITATION 100 OHM	=A4	+K2	EXCITATION 100 OHM	/21.B3
-R9b	=A4	+K2	EXCITATION 220 OHM	=A4	+K2	EXCITATION 220 OHM	/21.B4
-R10	=M	+M	FUEL PREHEATING	=M	+M	FUEL PREHEATING	/87.E5
-R10.X	=M	+M	PLUG FUEL PREHEATING	=M	+M	PLUG FUEL PREHEATING	/87.E5
-R11	=K	+K3	REAR WINDOW HEATER	=K	+K3	REAR WINDOW HEATER	/31.D5
-R11.X1	=K	+K3	PLUG REAR WINDOW HEATER	=K	+K3	PLUG REAR WINDOW HEATER	/31.D5
-R11.X2	=K	+K3	PLUG REAR WINDOW HEATER	=K	+K3	PLUG REAR WINDOW HEATER	/31.D5
-R16	=A4	+K2	DROP RESISTOR	=A4	+K2	DROP RESISTOR	/20.C3
-R121	=K	+K	MATCHING RESISTOR	=K	+K	MATCHING RESISTOR	/75.C5
-R121.	=K	+K	MATCHING RESISTOR	=K	+K	MATCHING RESISTOR	/108.D7
-R313	=K	+K4	CAN END	=K	+K4	CAN END	/72.C6

PROJECT: L524-L546\_Stufe1y\_7\_Serie ARTICLE CODE: 12412113 DRAWING INDEX: 000 DRAWING NUMBER: 1560 00190 01 00

MACHINE TYPE: **LIDOS UNIT** MACHINE SERIAL NUMBER: **XXXXX** **LIEBHERR** FACTORY LBH

BMK-INDEX: **E PLAN** SHEET: 12 FROM: 136

creation date: 17.05.2016 11:34

CAN: INPUT HIGH BEAM IHighBeam_MG AZINPUT 5	CAN: A27-PWR1-4A-4 ORBackLight_MG -A27 REVERSING LAMP OUTLET #57,05
---	---

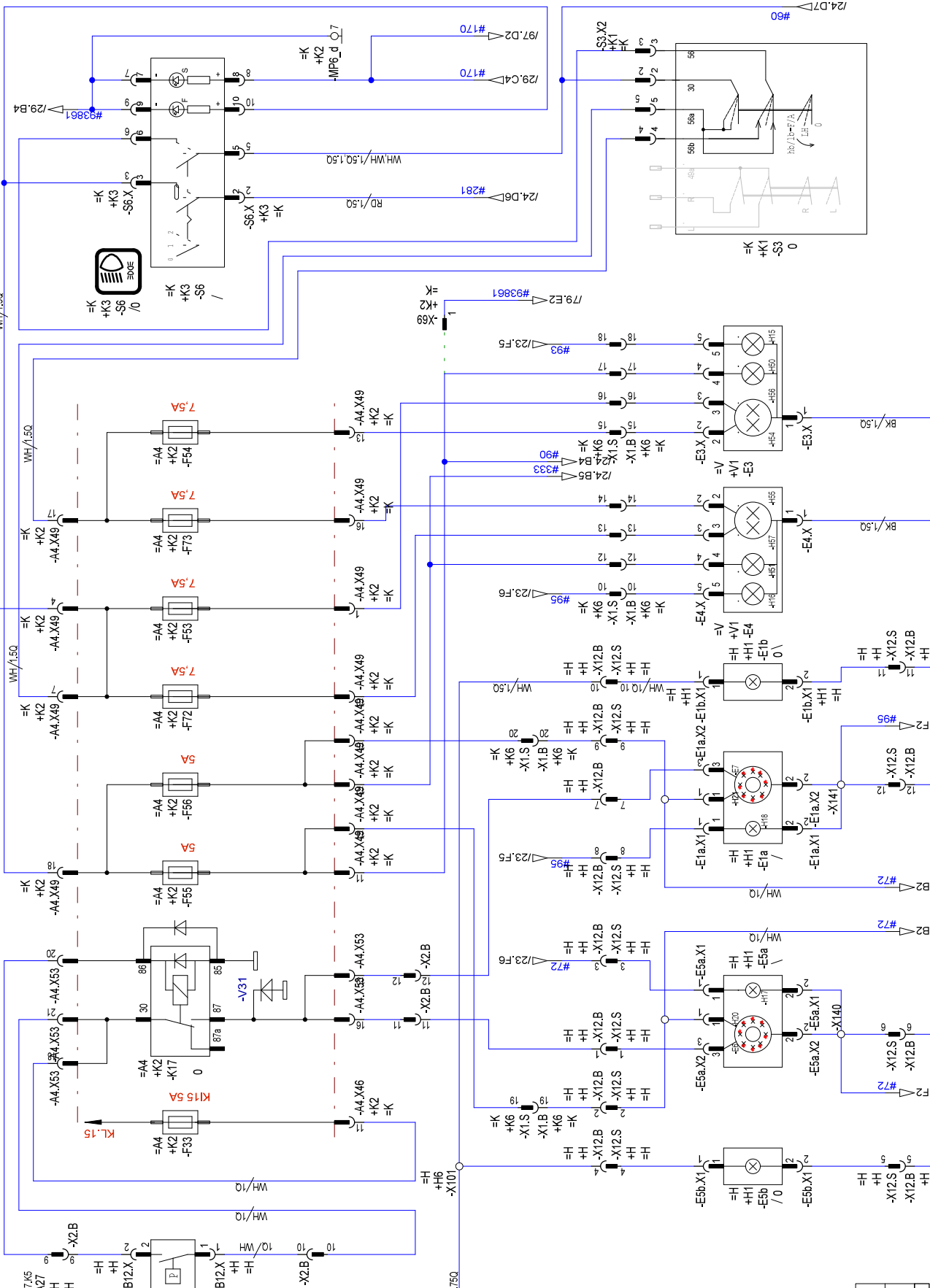

PROJECT: L524-L546\_Stufe1y\_7\_Serie  
 DRAWING NUMBER: 1560 00190 01 00  
 DRAWING INDEX: 000  
 ARTICLE CODE: 12412113

ISO 18018: The reproduction, distribution and utilization of this document as well as the communication of its contents to others without express authorization is prohibited. Offenders will be held liable for the payment of damages. All rights reserved in the event of the grant of a patent, utility model or design.

MACHINE TYPE: **LIDOS UNIT**

MACHINE SERIAL NUMBER: **XXXXX**

**LIEBHERR**  
 FACTORY LBH

LIGHTING  
 E PLAN

SHEET: 22 FROM: 136  
 CREATION DATE: 17.05.2016 11:34

PROJECT: L524-L546\_StufeIV\_7\_Serie  
 ARTICLE CODE: 12412113  
 DRAWING INDEK: 000  
 DRAWING NUMBER: 1560 00190 01 00

15018016: The reproduction, distribution and utilization of this document as well as the communication of its contents to others without express authorization is prohibited. Offenders will be held liable for the payment of damages. All rights reserved in the event of the grant of a patent, utility model or design.

MACHINE TYPE  
**LIDOS UNIT**

MACHINE SERIAL NUMBER  
**XXXX**

**LIEBHERR**  
 FACTORY LBH

OPTION BEACONLIGHT  
 E PLAN

SHEET: 32 FROM: 136  
 CREATION DATE: 17.05.2016 11:34

1 2 3 4 5 6 7 8

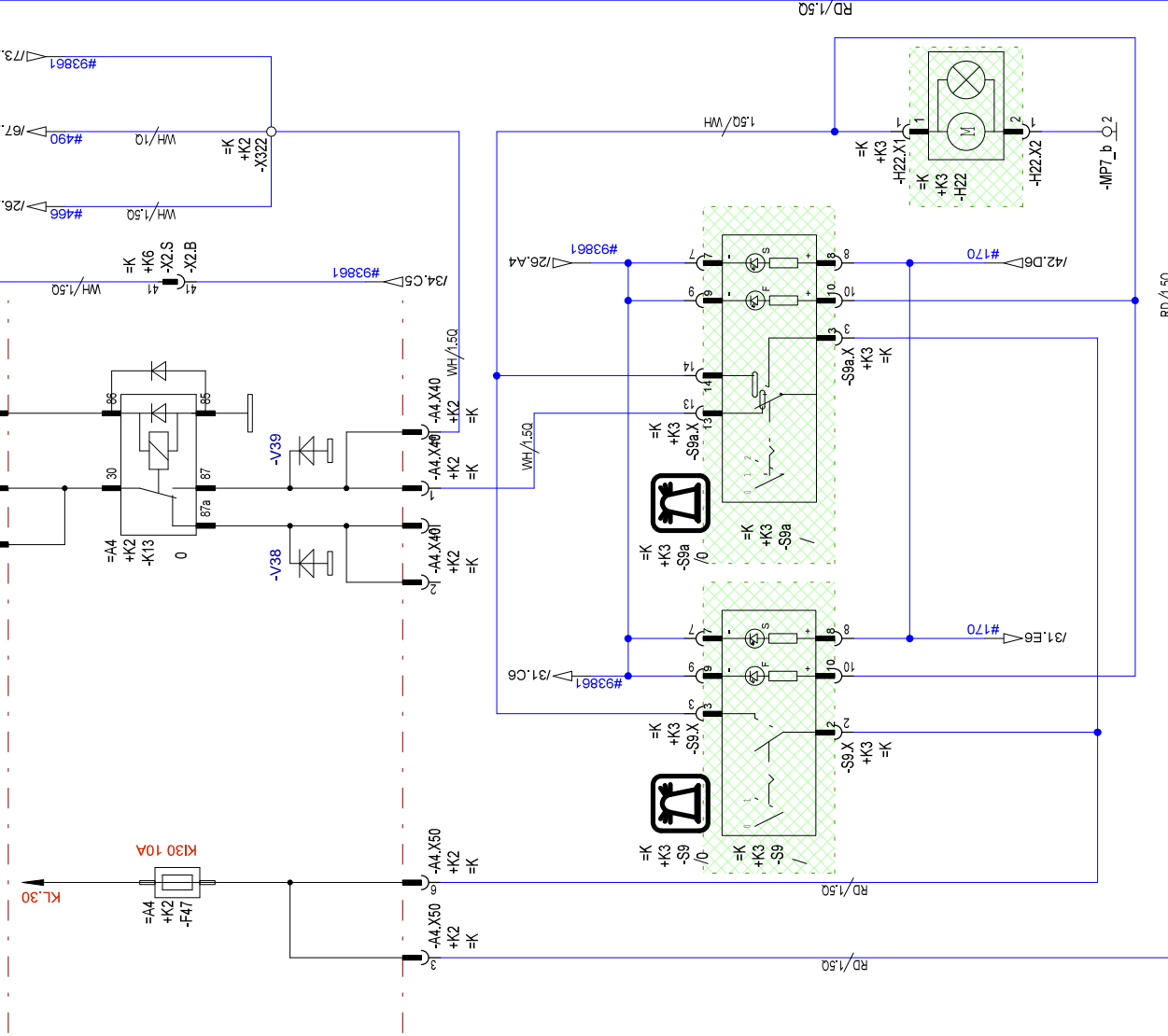

PROJECT: L524-L546\_Stufe1y\_7\_Serie ARTICLE CODE: 12412113 DRAWING NUMBER: 1560 00190 01 00 DRAWING INDEX: 000

1 CAN: /51.D3 /123.B5 /123.E2 -A700 +M =M  
 DPF REGENERATION SUPPRESS ENGANIG A700.42  
 42 X3  
 -A700.X3  
 +M =M  
 WH/10

2 CAN: /51.D3 /123.E2 -A700 +M =M  
 DPF REGENERATION REQUEST ENGANIG A700.38  
 38 X3  
 -A700.X3  
 +M =M  
 WH/10

3 CAN: /51.D3 /123.C5 -A700 +M =M  
 DPF REGENERATION SUPPRESS INFORMATION A700.51  
 51 X3  
 -A700.X3  
 +M =M  
 WH/10

4 CAN: /51.D3 /123.E2 -A700 +M =M  
 DPF REGENERATION REQUEST INFORMATION A700.35  
 35 X3  
 -A700.X3  
 +M =M  
 WH/10

5 CAN: /51.D3 /123.B5 /123.E2 -A700 +M =M  
 OUTLET OPERATING STATUS LAMP A700.45  
 45 X3  
 -A700.X3  
 +M =M  
 WH/10

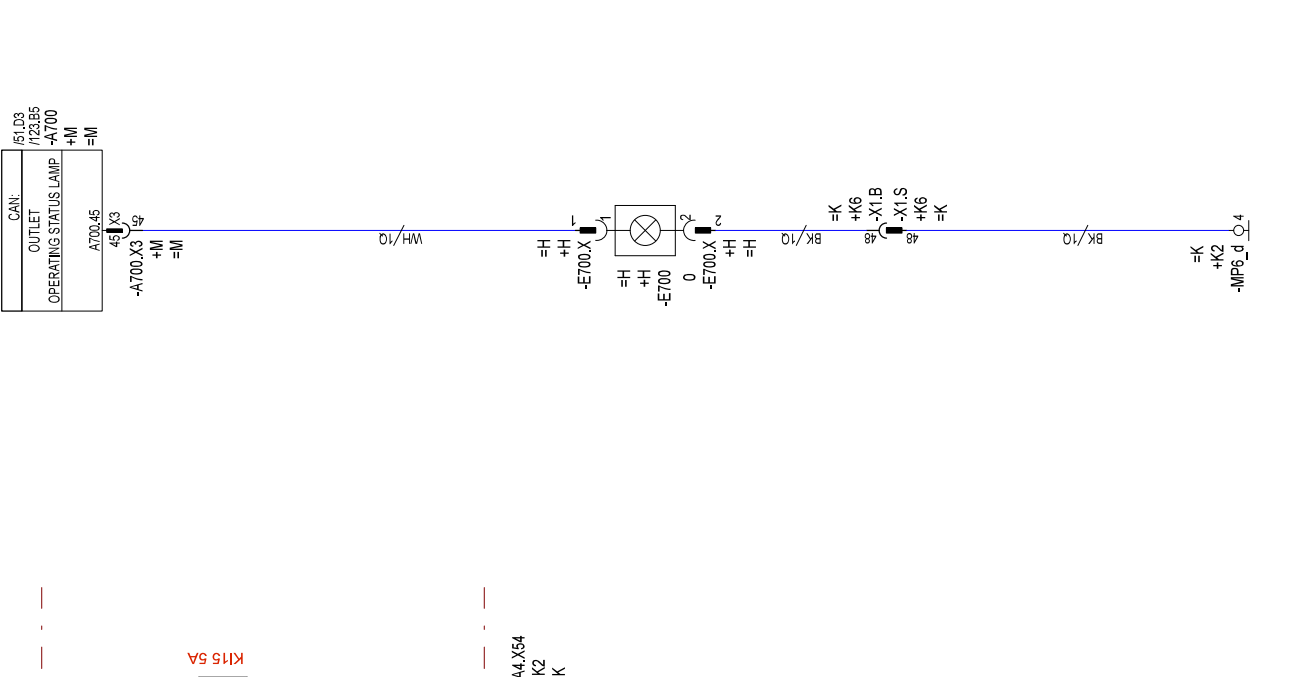

MACHINE TYPE  
**LIDOS UNIT**

MACHINE SERIAL NUMBER  
**XXXX**

**LIEBHERR**  
 FACTORY LBH

REGENERATION DIESEL PARTICULATE FILTER  
 E PLAN

SHEET: 42 FROM: 136  
 CREATION DATE: 17.05.2016 11:34

1 2 3 4 5 6 7 8

F 7 8

1 2 3 4 5 6 7 8

1 2 3 4 5 6 7 8

1 2 3 4 5 6 7 8

1 2 3 4 5 6 7 8

1 2 3 4 5 6 7 8

1 2 3 4 5 6 7 8

1 2 3 4 5 6 7 8

1 2 3 4 5 6 7 8

1 2 3 4 5 6 7 8

1 2 3 4 5 6 7 8

1 2 3 4 5 6 7 8

1 2 3 4 5 6 7 8

1 2 3 4 5 6 7 8

1 2 3 4 5 6 7 8

1 2 3 4 5 6 7 8

1 2 3 4 5 6 7 8

1 2 3 4 5 6 7 8

1 2 3 4 5 6 7 8

1 2 3 4 5 6 7 8

1 2 3 4 5 6 7 8

1 2 3 4 5 6 7 8

1 2 3 4 5 6 7 8

1 2 3 4 5 6 7 8

1 2 3 4 5 6 7 8

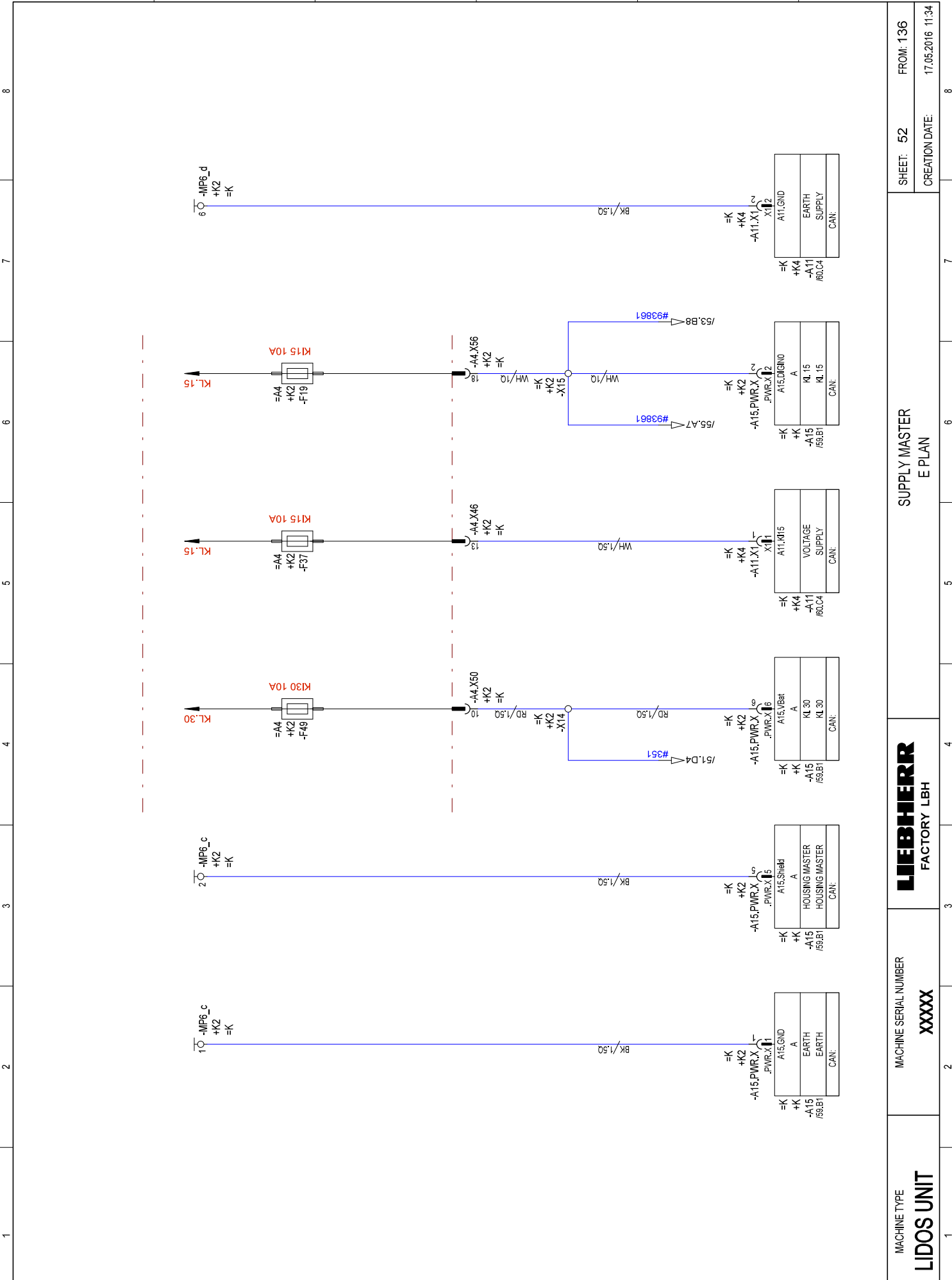

PROJECT: L524-L546\_StufeIV\_7\_Serie  
 DRAWING NUMBER: 1560 00190 01 00  
 DRAWING INDEX: 000  
 ARTICLE CODE: 12412113

ISO 19016: The reproduction, distribution and utilization of this document as well as the communication of its contents to others without express authorization is prohibited. Offenders will be held liable for the payment of damages. All rights reserved in the event of the grant of a patent, utility model or design.

MACHINE TYPE <b>LIDOS UNIT</b>	MACHINE SERIAL NUMBER <b>XXXXX</b>	<b>LIEBHERR</b> FACTORY LBH	SUPPLY MASTER E PLAN		SHEET: 52	FROM: 136
					CREATION DATE: 17.05.2016 11:34	

ARTICLE CODE: 12412113  
DRAWING INDEX: 000

PROJECT: L52-L546\_Stufelv\_7\_Serie  
DRAWING NUMBER: 1560 00190 01 00

ISO 19018: The reproduction, distribution and utilization of this document as well as the communication of its contents to others without express authorization is prohibited. Offenders will be held liable for the payment of damages. All rights reserved in the event of the grant of a patent, utility model or design.

=K +K2		-A30		Modul Nr.: Modulname:		LITU_GRUNDGERÄT					
Phys.Adr.	Blatt	EA	Beschreibung	Stecker	Pin	Phys.Adr.	Blatt	EA	Beschreibung	Stecker	Pin
A30.1			SUPPLY SAT MODULE		1	A30.25			CAN Low 1		25
A30.2			KH15 SAT MODULE		2	A30.26			CAN Low 2		26
A30.3			NC		3	A30.27			NC		27
A30.4			NC		4	A30.28	/44.E1		SUPPLY KL30		28
A30.5	/44.F4		DCD SIGNAL CONTROL		5	A30.29			EARTH		29
A30.6	/44.F3		DTR SIGNAL CONTROL		6	A30.30			TX1 SAT MODULE		30
A30.7			NC		7	A30.31			CTS SAT MODULE		31
A30.8	/44.F6		OUTLET 3A		8	A30.32			TX1		32
A30.9			SPEED DIESEL ENGINE		9	A30.33	/44.F5		TX1 SIGNAL CONTROL		33
A30.10			EARTH GENERAL		10	A30.34	/44.F7		CTS SIGNAL CONTROL		34
A30.11			NC		11	A30.35			DIGITAL INPUT 1		35
A30.12			CAN END		12	A30.36			EARTH GENERAL		36
A30.13	/44.E2		INPUT KL15		13	A30.37			ANALOG INPUT 1		37
A30.14			OUTLET 3A		14	A30.38			EARTH GENERAL		38
A30.15			OUTLET KL30		15	A30.39			CAN High 1		39
A30.16			RXD SAT MODULE		16	A30.40			CAN High 2		40
A30.17			RTS SAT MODULE		17	A30.41			EARTH GENERAL		41
A30.18			RX1		18	A30.42	/44.E3		EARTH GENERAL		42
A30.19	/44.F5		RXD SIGNAL CONTROL		19				GND		
A30.20	/44.F8		RTS SIGNAL CONTROL		20				GND		
A30.21			DIGITAL INPUT 2		21						
A30.22			EARTH GENERAL		22						
A30.23			ANALOG INPUT 2		23						
A30.24			EARTH GENERAL		24						

MACHINE TYPE  
**LIDOS UNIT**

MACHINE SERIAL NUMBER  
**XXXXX**

**LIEBHERR**  
FACTORY LBH

GENERAL OUTLAY TELEMETRY SYSTEM LIDAT  
E PLAN

SHEET: 62 FROM: 136  
CREATION DATE: 17.05.2016 11:34

PROJECT: 12412113

ARTICLE CODE: 000

DRAWING INDEX: 1560 00190 01 00

DRAWING NUMBER: 1524-L546\_Stufe1v\_7\_Serie

ISO 19018: The reproduction, distribution and utilization of this document for the payment of damages. All rights reserved in the event of the grant or a patent, utility model or design.

MACHINE TYPE

LIDOS UNIT

MACHINE SERIAL NUMBER

XXXX

**LIEBHERR**  
FACTORY LBH

OPTION IMMOBILISER  
E PLAN

SHEET: 72

FROM: 136  
CREATION DATE: 17.05.2016 11:34



=K +K -A9		10663904 <b>CAN-IMMOBILISER</b>			
ADDRESS	SHEET	EA	vom 1	vom 2	Pin
	/72.D1	EARTH	CLAMP 15	SUPPLY EARTH	1
	/72.D3	CLAMP 30	CAN_LOW IN	CLAMP 15	2
	/72.D4	CAN_LOW IN	CAN_HIGH IN	SUPPLY	3
	/72.D6			CAN_Low IN	4
	/72.D7			CAN_High IN	5

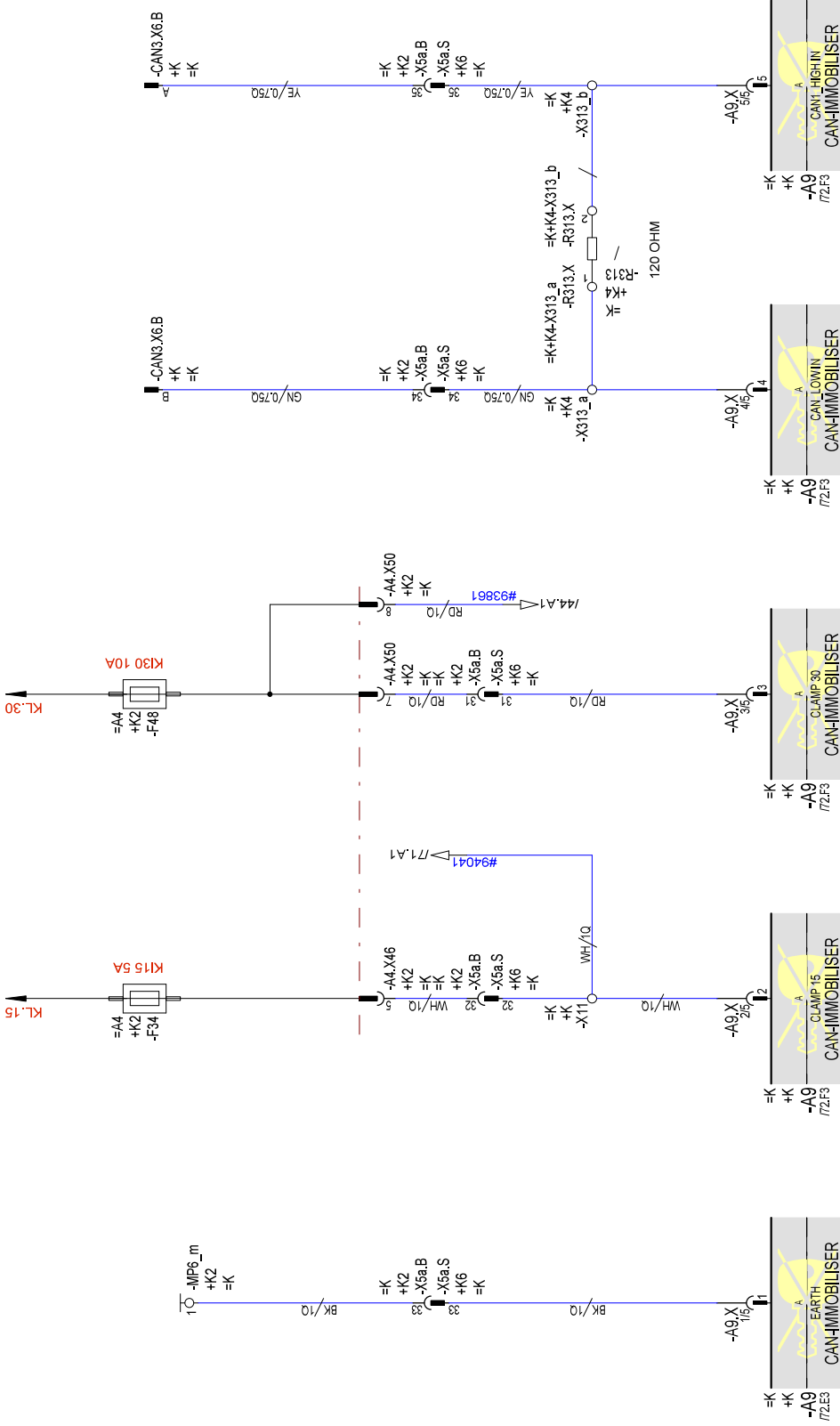

PROJECT: L524-L546\_StufeIV\_7\_Serie  
 ARTICLE CODE: 12412113  
 DRAWING INDEK: 000  
 DRAWING NUMBER: 1560 00190 01 00

ISO 19016: The reproduction, distribution and utilization of this document as well as the communication of its contents to others without express authorization is prohibited. Offenders will be held liable for the payment of damages. All rights reserved in the event of a grant of a patent, utility model or design.

MACHINE TYPE  
**LIDOS UNIT**

MACHINE SERIAL NUMBER  
**XXXXX**

**LIEBHERR**  
 FACTORY LBH

OPTION MIRROR ADJUSTMENT  
 E PLAN

SHEET: 82 FROM: 136  
 CREATION DATE: 17.05.2016 11:34

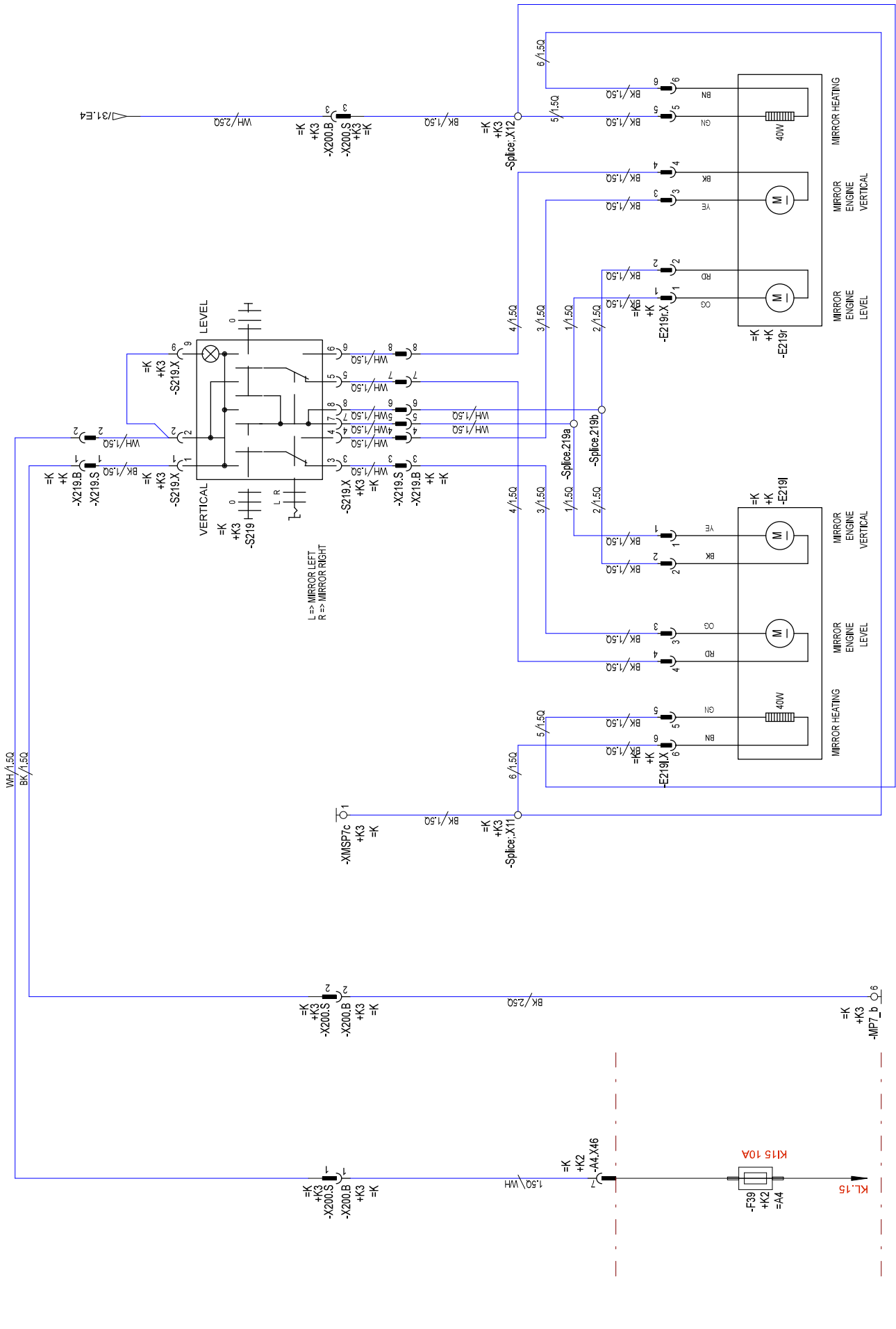

1 2 3 4 5 6 7 8

A B C D E F

PROJECT: L524-L546\_Stufe1\_7\_Serie  
 ARTICLE CODE: 12412113  
 DRAWING INDEK: 000

DRAWING NUMBER: 1560 00190 01 00

ISO 19018: The reproduction, distribution and utilization of this document as well as the communication of its contents to others without express authorization is prohibited. Offenders will be held liable for the payment of damages. All rights reserved in the event of the grant or a patent, utility model or design.

MACHINE TYPE  
**LIDOS UNIT**

MACHINE SERIAL NUMBER  
**XXXX**

**LIEBHERR**  
 FACTORY LBH

OPTION JOYSTICK STEERING  
 E PLAN

SHEET: 92 FROM: 136

CREATION DATE: 17.05.2016 11:34

1 2 3 4 5 6 7 8

CAN 1

CAN 2

CAN 3

CAN 4

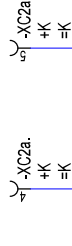

-XC2a.  
 +K  
 =K

-XC2a.  
 +K  
 =K

GN/0,750

=K  
 +K  
 -XC2b.

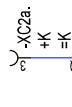

-XC2a.  
 +K  
 =K

-XC2a.  
 +K  
 =K

-X72.B  
 -X72.S

GN/0,750

=K  
 +K  
 -A29.X1

X1,F1  
 X1,F3

=K  
 +K6  
 -A29

A29:CANL1  
 CANL1  
 A29  
 CANL Line 1  
 B1,C5  
 CAN  
 CANL Line 1  
 A29:CANH1  
 CANH1  
 A29  
 CANH Line 1  
 B1,C5  
 CAN

GN/0,750

=K  
 +K  
 -XC2b.

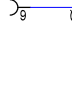

-XC2a.  
 +K  
 =K

-XC2a.  
 +K  
 =K

-X72.B  
 -X72.S

YE/0,750

=K  
 +K6  
 -A29.X1

X1,F1  
 X1,F3

=K  
 +K6  
 -A29

A29:CANL1  
 CANL1  
 A29  
 CANL Line 1  
 B1,C5  
 CAN  
 CANL Line 1  
 A29:CANH1  
 CANH1  
 A29  
 CANH Line 1  
 B1,C5  
 CAN

YE/0,750

=K  
 +K  
 -XC2b.



-XC2a.  
 +K  
 =K

-XC2a.  
 +K  
 =K

-X72.B  
 -X72.S

GN/0,750

=K  
 +K6  
 -A29.X3

X3,F1  
 X3,F3

=K  
 +K6  
 -A29

A29:CANL2  
 CANL2  
 A29  
 CANL Line 2  
 B1,G9  
 CAN  
 CANL Line 2  
 A29:CANH2  
 CANH2  
 A29  
 CANH Line 2  
 B1,G9  
 CAN

GN/0,750

=K  
 +K  
 -XC2b.



-XC2a.  
 +K  
 =K

-XC2a.  
 +K  
 =K

-X72.B  
 -X72.S

YE/0,750

=K  
 +K6  
 -A29.X3

X3,F1  
 X3,F3

=K  
 +K6  
 -A29

A29:CANL2  
 CANL2  
 A29  
 CANL Line 2  
 B1,G9  
 CAN  
 CANL Line 2  
 A29:CANH2  
 CANH2  
 A29  
 CANH Line 2  
 B1,G9  
 CAN

YE/0,750

=K  
 +K  
 -XC2b.

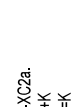

-XC2a.  
 +K  
 =K

-XC2a.  
 +K  
 =K

-X72.S  
 -X72.B

YE/0,750

=K  
 +K6  
 -A29.X3

X3,F1  
 X3,F3

=K  
 +K6  
 -A29

A29:CANL2  
 CANL2  
 A29  
 CANL Line 2  
 B1,G9  
 CAN  
 CANL Line 2  
 A29:CANH2  
 CANH2  
 A29  
 CANH Line 2  
 B1,G9  
 CAN

YE/0,750

=K  
 +K  
 -XC2b.

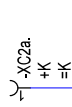

-XC2a.  
 +K  
 =K

-XC2a.  
 +K  
 =K

-X72.S  
 -X72.B

GN/0,750

=K  
 +K  
 -XC2b.

X3,F1  
 X3,F3

=K  
 +K  
 -XC2b.

GN/0,750

=K  
 +K  
 -XC2b.

12412113  
ARTICLE CODE:

000  
DRAWING INDEX:

L524-L546\_StufeIV\_7\_Serie  
1560 00190 01 00  
DRAWING NUMBER:

PROJECT:

ISO 19016: The reproduction, distribution and utilization of this document as well as the communication of its contents to others without express authorization is prohibited. Offenders will be held liable for the payment of damages. All rights reserved in the event of the grant of a patent, utility model or design.

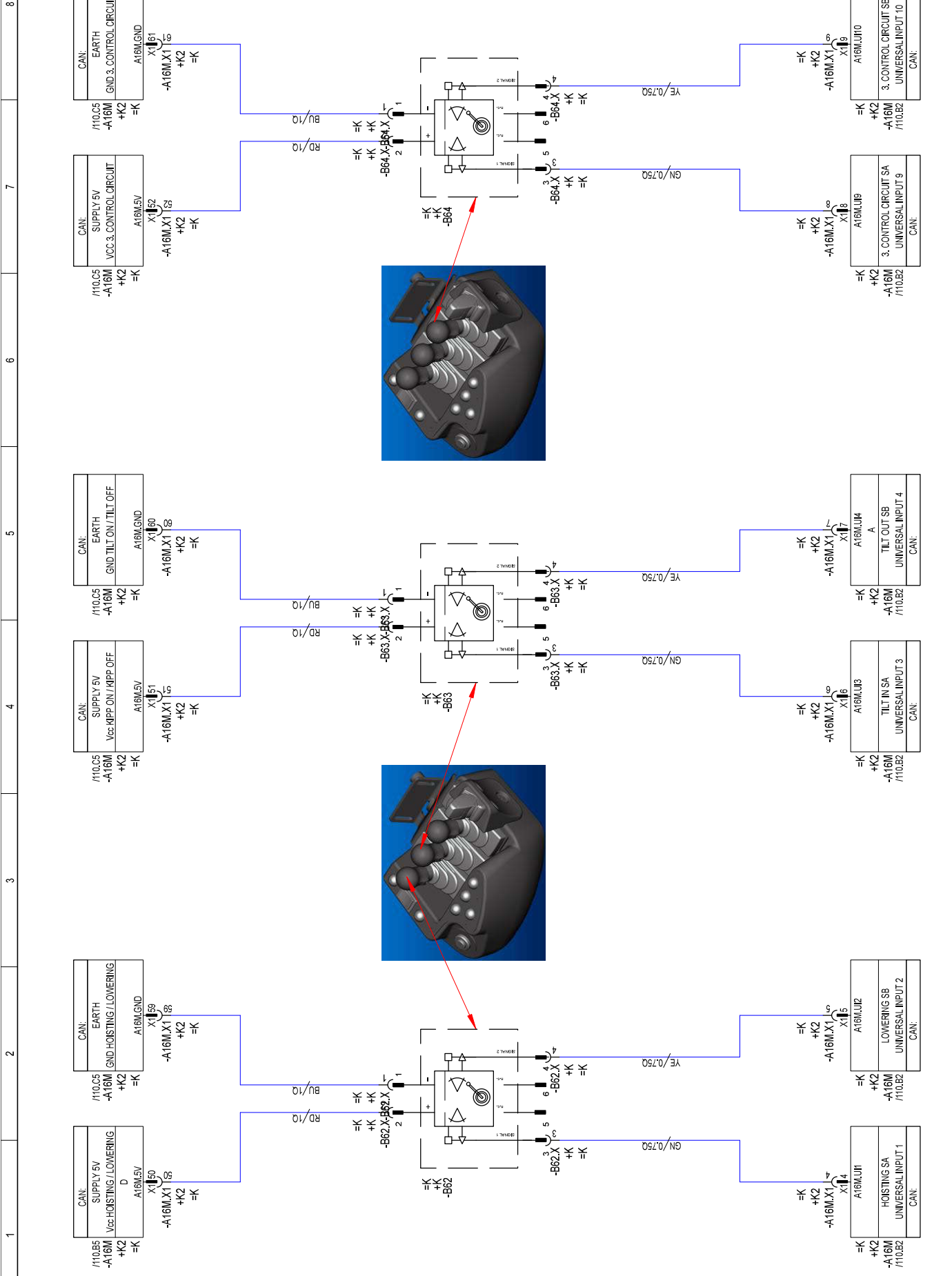

MACHINE TYPE  
**LIDOS UNIT**

MACHINE SERIAL NUMBER  
**XXXXX**

**LIEBHERR**  
FACTORY LBH

MULTI-LEVER CONTROL  
E PLAN

SHEET: 102 FROM: 136  
CREATION DATE: 17.05.2016 11:34

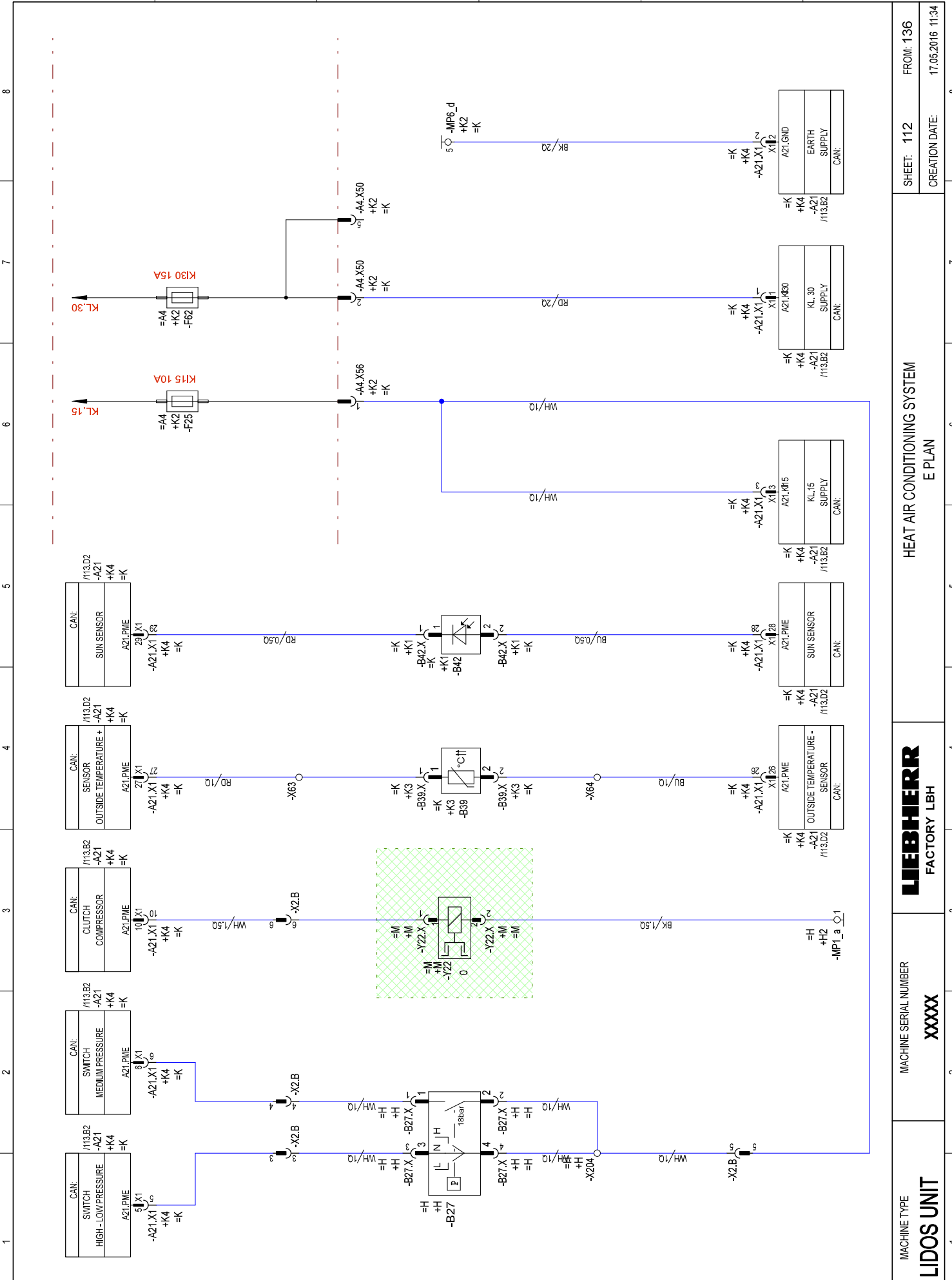

PROJECT: L524-L546\_StufeIV\_7\_Serie  
 DRAWING NUMBER: 1560 00190 01 00  
 DRAWING INDEX: 000  
 ARTICLE CODE: 12412113

PROJECT: L524-L546\_StufeIV\_7\_Serie  
 DRAWING NUMBER: 1560 00190 01 00  
 ARTICLE CODE: 12412113  
 DRAWNG INDEX: 000

ISO 19016: The reproduction, distribution and utilization of this document as well as the communication of its contents to others without express authorization is prohibited. Offenders will be held liable for the payment of damages. All rights reserved in the event of the grant of a patent, utility model or design.

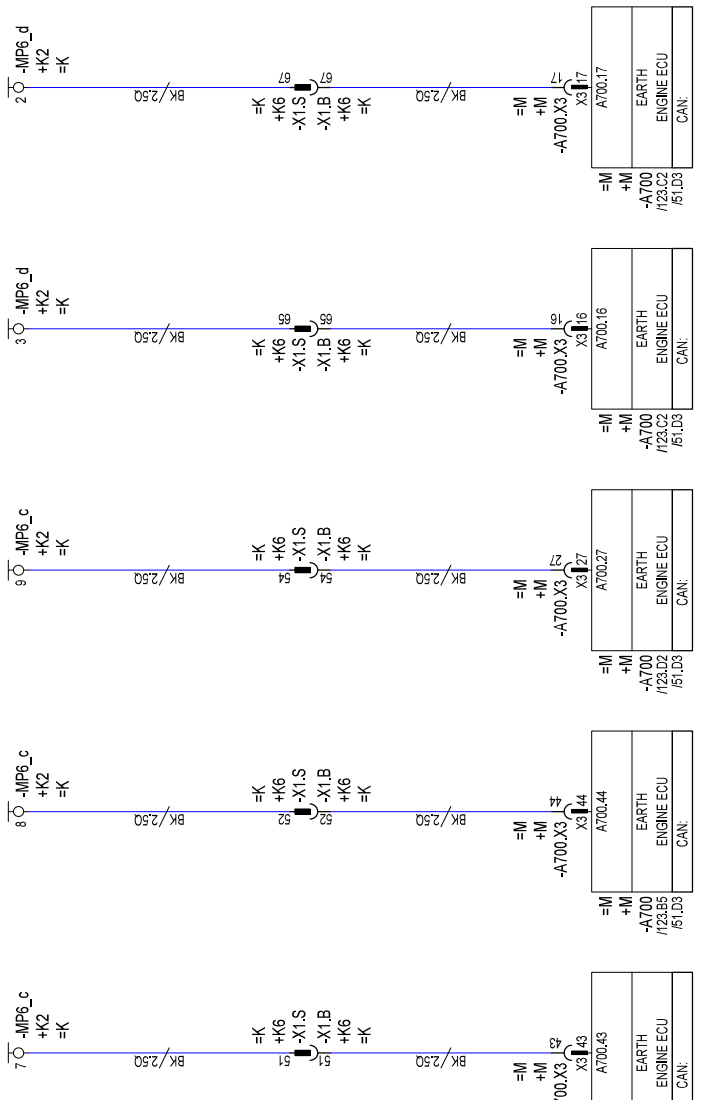

MACHINE TYPE  
**LIDOS UNIT**

MACHINE SERIAL NUMBER  
**XXXX**

**LIEBHERR**  
 FACTORY LBH

SUPPLY ENGINE ECU  
 E PLAN

SHEET: 122 FROM: 136  
 CREATION DATE: 17.05.2016 11:34



TYPE  
E-SPL

PROJECT: L524-L546 Sturteiv 7 Serie

NSO 16016 The reproduction, distribution and utilization of this document as well as the communication of its contents to others without express authorization is prohibited. Offenders will be held liable for the payment of damages. All rights reserved in the event of the grant of a patent, utility model or design.

REPLACEMENT FOR DRAWN

DATE 10.07.2019 12:59

INSPECTED

TECHNICAL REFEREE

CONFIDENTIAL

1

2

3

4

5

6

7

8

DESIGNATION  
E PLAN

**A3**

FACTORY LBH

10.07.2019 12:59

INSPECTED

TECHNICAL REFEREE

CONFIDENTIAL

1

2

3

4

5

6

7

8

BMK	SYSTEM	LOCATION	FUNCTION	PAGE
-1	=K	+K	CONNECTION RESISTANCE	/78.C5
-2	=K	+K	CONNECTION RESISTANCE	/118.D6
-3	=K	+K	CONNECTION RESISTANCE	/98.E5
-5	=H	+H	CONNECTION REVERSING OBSTACLE DETECTOR	/76.E5
-5	=M	+M	CONNECTION RESISTANCE	/137.E3
-6	=H	+H	CONNECTION REVERSING OBSTACLE DETECTOR	/76.E5
-7	=H	+H	CONNECTION REVERSING OBSTACLE DETECTOR	/76.E5
-94 Verb.	=K	+K	LINE END	/148.C4
-95 Verb.	=K	+K	LINE END	/148.C5
-560	=K	+K2	CONNECTION DIODE	/90.D4
-561	=K	+K2	CONNECTION DIODE	/90.D7
-562	=K	+K2	CONNECTION DIODE	/89.B2
-A3	=K	+K3	RADIO	/33.D3
-A3.X1	=K	+K3	PLUG RADIO	/33.D4
-A3.X2	=K	+K3	PLUG RADIO	/33.E3
-A4	=K	+K2	FUSE AND RELAY BOARD	/22.C5
-A4.X40	=K	+K2	PLUG RELAY BOARD	/35.C4
-A4.X41	=K	+K2	PLUG RELAY BOARD	/74.D6
-A4.X42	=K	+K2	PLUG RELAY BOARD	/34.A5
-A4.X43	=K	+K2	PLUG RELAY BOARD	/73.D5
-A4.X44	=K	+K2	PLUG RELAY BOARD	/26.C4
-A4.X45	=K	+K2	PLUG RELAY BOARD	/48.D3
-A4.X46	=K	+K2	PLUG RELAY BOARD	/27.C7
-A4.X47	=K	+K2	PLUG RELAY BOARD	/28.D6
-A4.X48	=K	+K2	PLUG RELAY BOARD	/22.B3
-A4.X49	=K	+K2	PLUG RELAY BOARD	/22.B3
-A4.X50	=K	+K2	PLUG RELAY BOARD	/75.C5
-A4.X51	=K	+K2	PLUG RELAY BOARD	/131.C2
-A4.X52	=K	+K2	PLUG RELAY BOARD	/56.C5
-A4.X53	=K	+K2	PLUG RELAY BOARD	/44.E3
-A4.X54	=K	+K2	PLUG RELAY BOARD	/66.C4
-A4.X55	=K	+K2	PLUG RELAY BOARD	/30.B6
-A4.X56	=K	+K2	PLUG RELAY BOARD	/122.C6
-A4.X57	=K	+K2	PLUG RELAY BOARD	/24.B5
-A4b	=K	+K2	FUSE AND RELAY BOARD JOYSTICK STEERING	/103.B4
-A4b.X58	=K	+K2	PLUG RELAY BOARD JOYSTICK STEERING	/103.C2

BMK	SYSTEM	LOCATION	FUNCTION	PAGE
-A4b.X59	=K	+K2	PLUG RELAY BOARD JOYSTICK STEERING	/106.D5
-A4b.X60	=K	+K2	PLUG RELAY BOARD JOYSTICK STEERING	/107.B3
-A9	=K	+K	IMMOBILISER	/75.E3
-A9.M	=K	+K	IMMOBILISER AT MULTI-LEVER CONTROL	/118.E3
-A9.M.X	=K	+K	PLUG IMMOBILISER	/118.D2
-A9.X	=K	+K	PLUG IMMOBILISER	/75.D2
-A9.X	=K	+K4	PLUG IMMOBILISER	/149.C6
-A11	=K	+K4	MAIN KEYPAD	/63.B3
-A11.X1	=K	+K4	PLUG MAIN KEYPAD	/53.D5
-A13	=K	+K3	DISPLAY UNIT	/46.A1
-A13.X	=K	+K3	ETHERNET PLUG DISPLAY	/46.C1
-A13a.X	=K	+K3	PLUG SUPPLY PME DISPLAY	/46.B2
-A15	=K	+K	MASTER CONTROL	/62.A1
-A15.CAN.X	=K	+K2	PLUG MASTER CONTROL	/51.B2
-A15.CAN.X1	=K	+K	PLUG MASTER 4	/147.A4
-A15.COM1.X	=K	+K	PLUG MASTER CONTROL COM 1	/79.E3
-A15.COM2.X	=K	+K2	PLUG MASTER CONTROL COM2	/47.A3
-A15.COM4.X	=K	+K2	PLUG MASTER CONTROL COM 4	/54.B7
-A15.PWR.X	=K	+K2	PLUG MASTER CONTROL	/55.E2
-A15.PWR.X1	=K	+K	PLUG MASTER 4	/147.A5
-A15.X1	=K	+K	PLUG MASTER 5	/147.E3
-A16M	=K	+K2	INPUT MODULE MULTI-LEVER CONTROL	/120.A1
-A16M.X1	=K	+K2	PLUG INPUT MODULE MULTI-LEVER CONTROL	/111.E1
-A21	=K	+K4	HEAT AIR CONDITIONING SYSTEM	/123.A1
-A21.X1	=K	+K4	PLUG HEAT AIR CONDITIONING SYSTEM	/53.D2
-A21a	=K	+K4	AIR CON ELECTRONICS CC01 42 POLIG	/129.B1
-A21a.X2	=K	+K4	PLUG AIR CON ELECTRONICS CC01	/125.B2
-A23	=V	+V1	CONTROL DEVICE WEIGHING DEVICE	/81.C3
-A23.X1	=V	+V1	PLUG WEIGHING DEVICE	/78.B1
-A23.X2	=V	+V1	PLUG WEIGHING DEVICE	/80.D6
-A24.X	=K	+K1	PLUG DISPLAY UNIT WEIGHING DEVICE	/78.C6
-A25	=K	+K1	PRINTER	/79.A3
-A25.X1	=K	+K1	PLUG WEIGHING DEVICE	/79.B2
-A26	=K	+K4	PILOT CONTROL SENSOR	/64.B3
-A26.X	=K	+K4	PLUG SENSOR GRIP	/52.E2
-A27	=H	+H	COMPACT MODULE 1	/60.B5

REPLACEMENT FOR DRAWN		DESIGNATION		DESCRIPTION		SYSTEM		PLACE	
DATE	10.07.2019 12:59	E PLAN		BMK-INDEX		ARTICLE CODE	INDEX	SHEET	FROM
INSPECTED						12933726	200	6	149
TECHNICAL REFEREE						1560 00190 01 00	200	6	149

REPLACEMENT FOR DRAWN		DESIGNATION		DESCRIPTION		SYSTEM		PLACE	
DATE	10.07.2019 12:59	E PLAN		BMK-INDEX		ARTICLE CODE	INDEX	SHEET	FROM
INSPECTED						12933726	200	6	149
TECHNICAL REFEREE						1560 00190 01 00	200	6	149

REPLACEMENT FOR DRAWN		DESIGNATION		DESCRIPTION		SYSTEM		PLACE	
DATE	10.07.2019 12:59	E PLAN		BMK-INDEX		ARTICLE CODE	INDEX	SHEET	FROM
INSPECTED						12933726	200	6	149
TECHNICAL REFEREE						1560 00190 01 00	200	6	149

REPLACEMENT FOR DRAWN		DESIGNATION		DESCRIPTION		SYSTEM		PLACE	
DATE	10.07.2019 12:59	E PLAN		BMK-INDEX		ARTICLE CODE	INDEX	SHEET	FROM
INSPECTED						12933726	200	6	149
TECHNICAL REFEREE						1560 00190 01 00	200	6	149





PROJECT: L524-L546 StrielV\_7\_Serie

TYPE E-SP

REPLACEMENT FOR DRAWN	0
DATE	10.07.2019 12:59
INSPECTED	
TECHNICAL REFEREE	

**LIEBHERR**  
**A3**  
FACTORY LBH

DESIGNATION  
E PLAN

DESCRIPTION  
SPEED-PEDAL - INCH PEDAL

ARTICLE CODE	12939726
DRAWING NUMBER	1560 00190 01 00
INDEX	200
SHEET 36	FROM 149
VERSION	002-2019 12/19

SYSTEM	PLACE
8	8

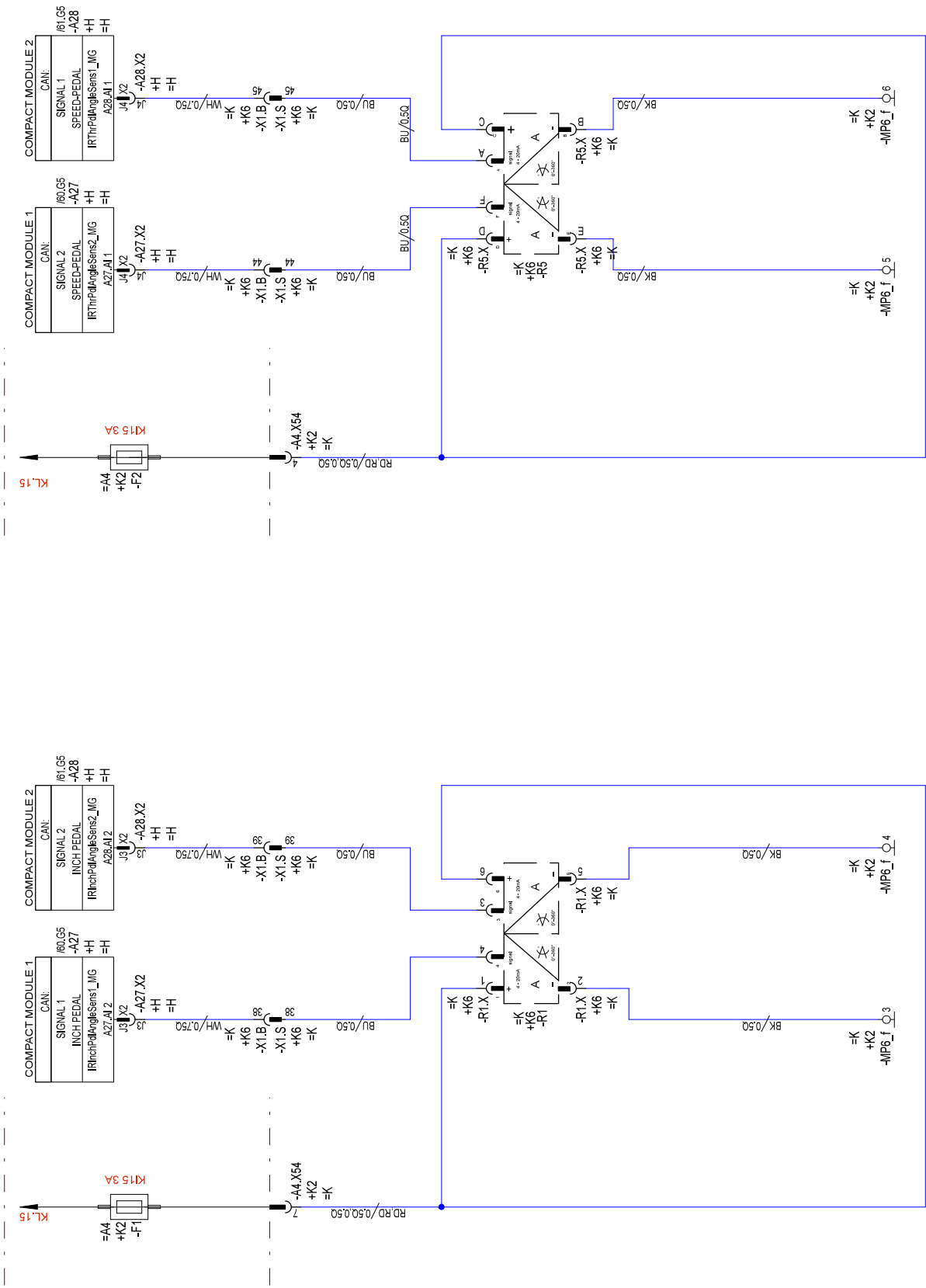





REPLACEMENT FOR DRAWN	0
DATE	10.07.2019 12:59
INSPECTED	
TECHNICAL REFEREE	

CONFIDENTIAL

1

2

3

4

5

6

7

8

9

10

11

12

13

14

15

16

17

18

19

20

21

22

23

24

25

26

27

28

29

30

31

32

REPLACEMENT FOR DRAWN

DATE

INSPECTED

TECHNICAL REFEREE

CONFIDENTIAL

1

2

3

4

5

6

7

8

9

10

11

12

13

14

15

16

17

18

19

20

21

22

23

24

25

26

27

28

29

30

31

32

33

34

35

36

37

38

39

40

41

42

43

44

45

REPLACEMENT FOR DRAWN

DATE

INSPECTED

TECHNICAL REFEREE

CONFIDENTIAL

1

2

3

4

5

6

7

8

9

10

11

12

13

14

15

16

17

18

19

20

21

22

23

24

25

26

27

28

29

30

31

32

33

34

35

36

37

38

39

40

41

42

43

44

45

REPLACEMENT FOR DRAWN

DATE

INSPECTED

TECHNICAL REFEREE

CONFIDENTIAL

1

2

3

4

5

6

7

8

9

10

11

12

13

14

15

16

17

18

19

20

21

22

23

24

25

26

27

28

29

30

31

32

33

34

35

36

37

38

39

40

41

42

43

44

45

REPLACEMENT FOR DRAWN

DATE

INSPECTED

TECHNICAL REFEREE

CONFIDENTIAL

1

2

3

4

5

6

7

8

9

10

11

12

13

14

15

16

17

18

19

20

21

22

23

24

25

26

27

28

29

30

31

32

33

34

35

36

37

38

39

40

41

42

43

44

45

REPLACEMENT FOR DRAWN

DATE

INSPECTED

TECHNICAL REFEREE

CONFIDENTIAL

1

2

3

4

5

6

7

8

9

10

11

12

13

14

15

16

17

18

19

20

21

22

23

24

25

26

27

28

29

30

31

32

33

34

35

36

37

38

39

40

41

42

43

44

45

REPLACEMENT FOR DRAWN

DATE

INSPECTED

TECHNICAL REFEREE

CONFIDENTIAL

1

2

3

4

5

6

7

8

9

10

11

12

13

14

15

16

17

18

19

20

21

22



150 16016. The reproduction, distribution and utilization of this document as well as the communication of its contents to others without express authorization is prohibited. Offenders will be held liable for the payment of damages. All rights reserved in the event of the grant of a patent, utility model or design.

PROJECT: L524-L546\_StufeV\_7\_Serie

TYPE E-SP.L

REPLACEMENT FOR DRAWN	0
DATE	10.07.2019 12:59
INSPECTED	
TECHNICAL REFEREE	

**LIBEHRER**  
FACTORY LBH

DESIGNATION  
E PLAN

DESCRIPTION  
OPTION MIRROR ADJUSTMENT

ARTICLE CODE	129393726
DRAWING NUMBER	1560 00190 01 00
INDEX	200

SYSTEM	PLACE
SHEET 86	FROM 149
ARTICLE CODE 129393726	VERSION
1560 00190 01 00	10.07.2019 12:59

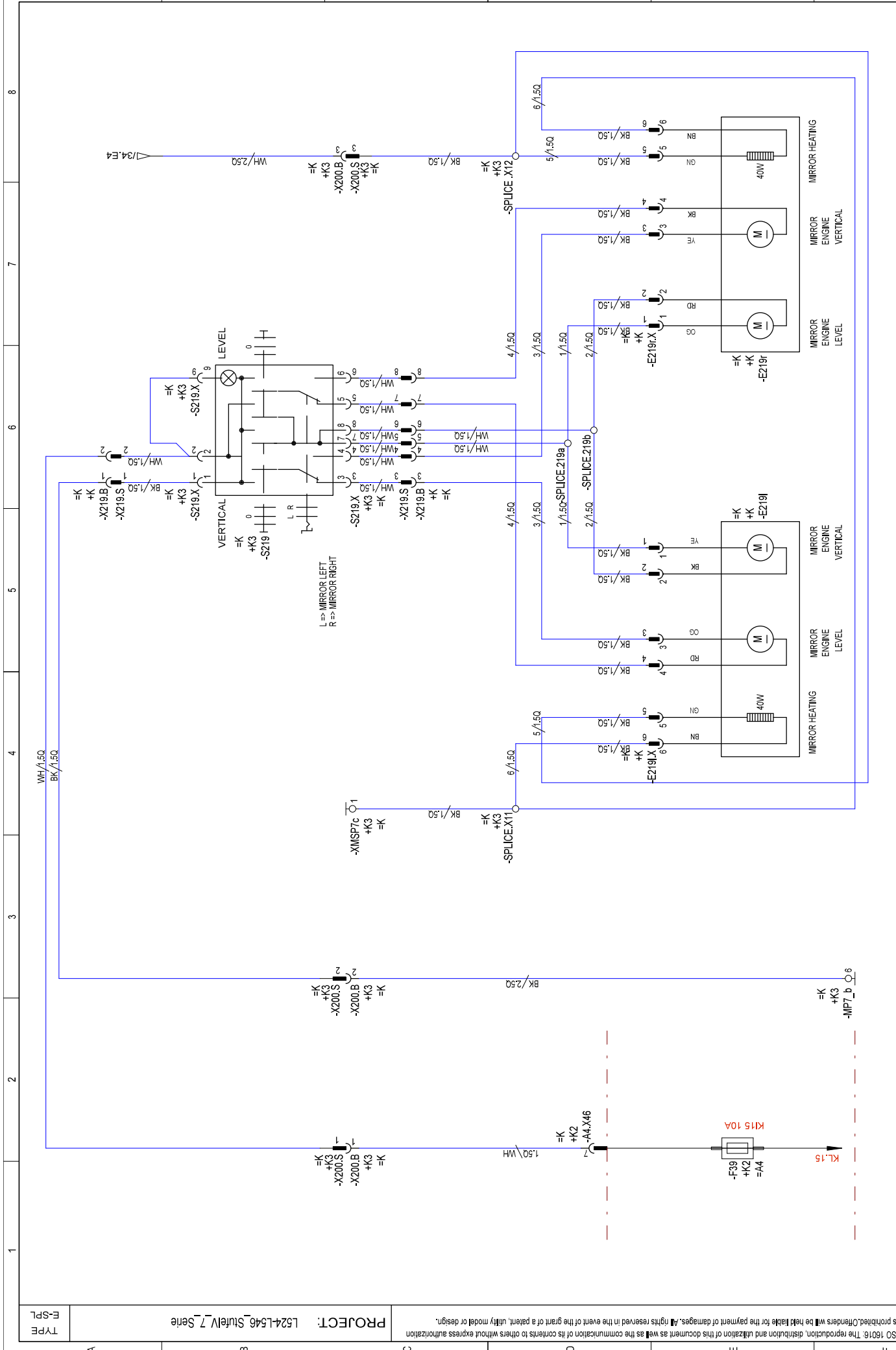

A B C D E F

1 2 3 4 5 6 7 8

A B C D E F

PROJECT: L524-L546\_StufeIV\_7\_Serie

TYPE E-SPL

REPLACEMENT FOR DRAWN	DATE	10.07.2019 12:59
INSPECTED		
TECHNICAL REFEREE		

CONFIDENTIAL

**LIEBHERR**  
FACTORY LBH

**A3**

DESIGNATION  
E PLAN

DESCRIPTION  
OPTION COOLANT PREHEATING

ARTICLE CODE	12939726	SYSTEM	PLACE
DRAWING NUMBER	INDEX	SHEET 96	FROM 149
1560 00190 01 00	200	ARTICLE CODE 1000708	VERSION 10022019 1219

8

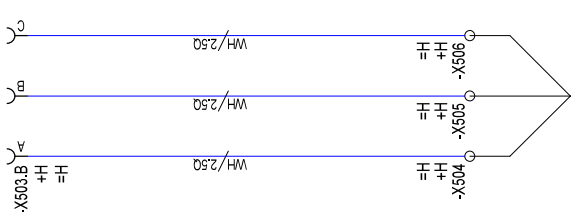

X505 <=> X503.B/A  
X504 <=> X503.B/B  
X506 <=> X503.B/C

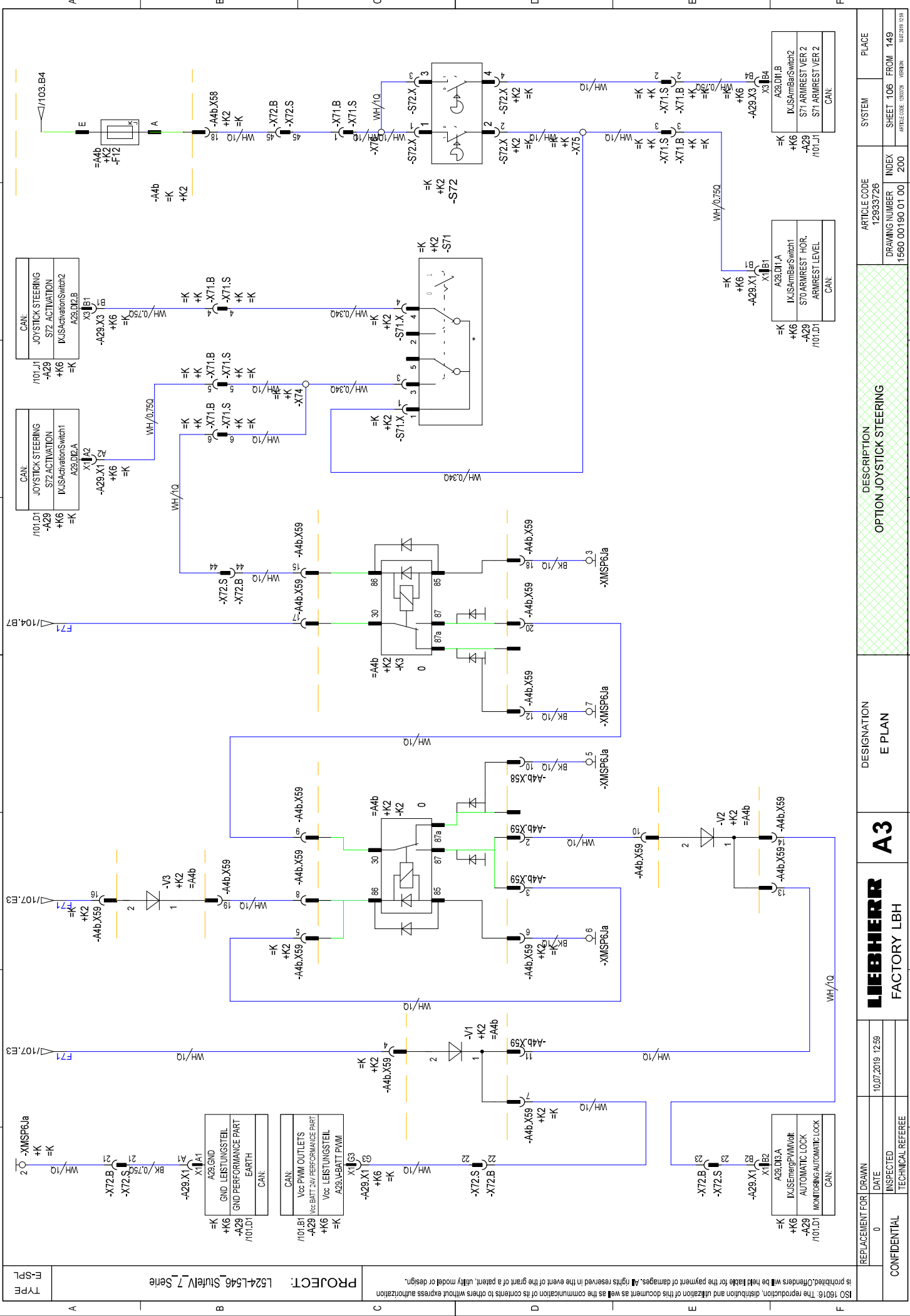

ISO 15026: The reproduction, distribution and utilization of this document as well as the communication of its contents to others without express authorization is prohibited. Offenders will be held liable for the payment of damages. All rights reserved in the event of the grant of a patent, utility model or design.

PROJECT: L524-L546\_StufeV\_7\_Serie

TYPE E-SPL

REPLACEMENT FOR DRAWN	DATE	10.07.2019 12:59
INSPECTED	TECHNICAL REFEREE	

CONFIDENTIAL

FACTORY LBH

**A3**

DESIGNATION  
E PLAN

DESCRIPTION  
MULTI-LEVER CONTROL

ARTICLE CODE 12939726  
DRAWING NUMBER 1560 00190 01 00  
INDEX 200

SYSTEM PLACE  
SHEET 116 FROM 149  
ARTICLE CODE 100078 VERBODEN 10.07.2019 12:59

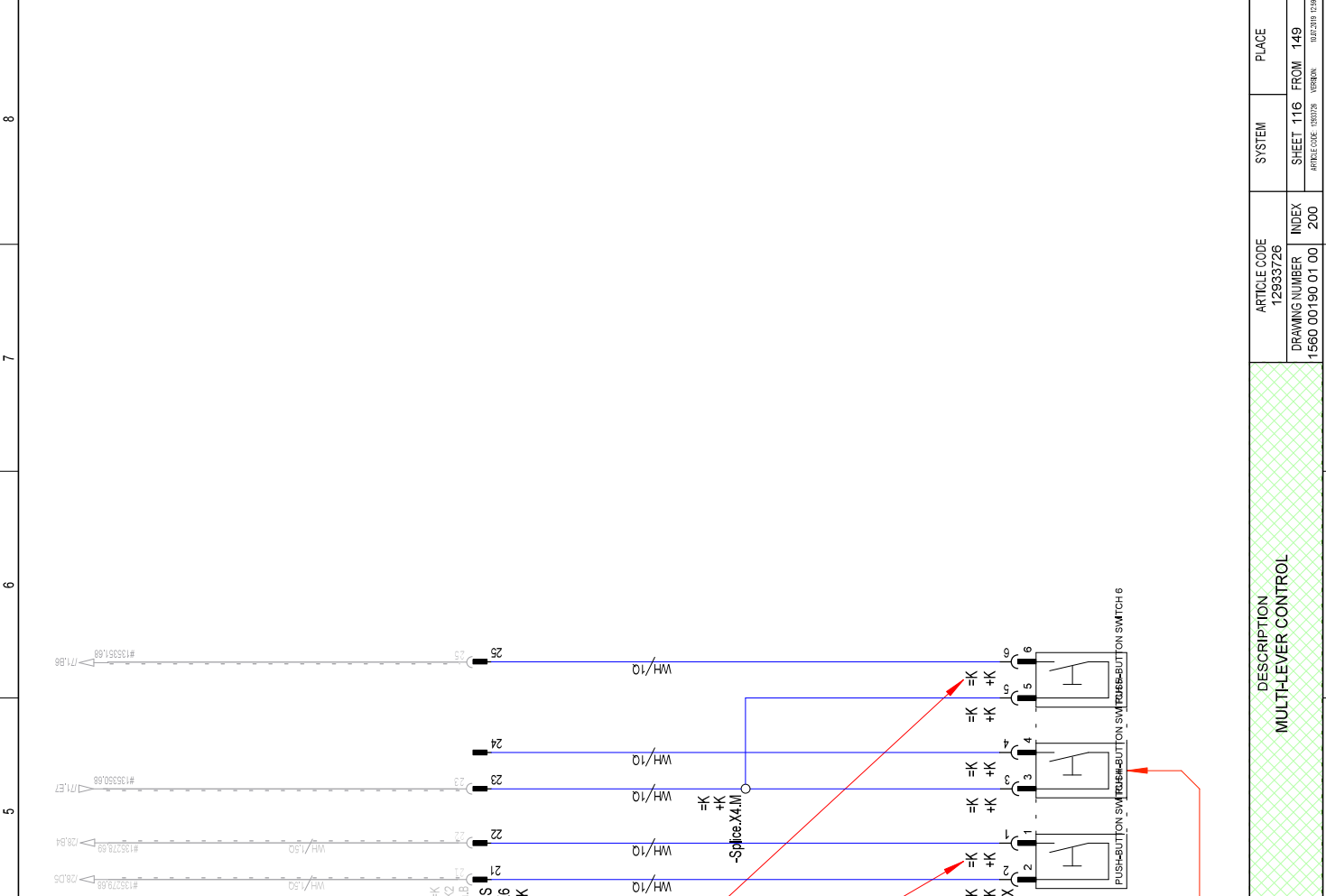

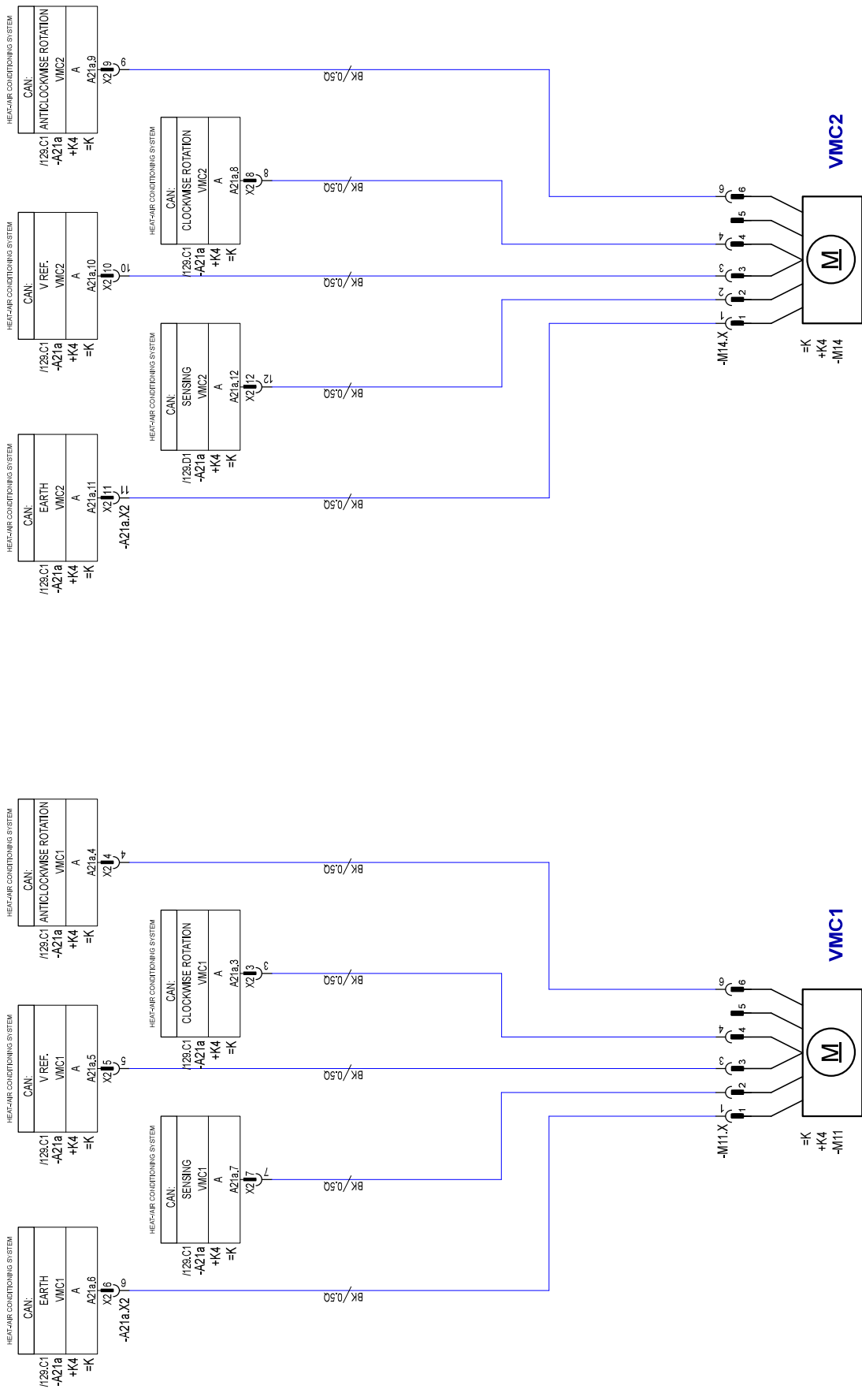

REPLACEMENT FOR DRAWN	DATE	10.07.2019 12:59
CONFIDENTIAL	INSPECTED	TECHNICAL REFERENCE

DESIGNATION	E PLAN	A3
DESCRIPTION	HEAT AIR CONDITIONING SYSTEM	FACTORY LBH

ARTICLE CODE	12939726	SYSTEM	PLACE
DRAWING NUMBER	1560 00190 01 00	INDEX	SHEET 126 FROM 149
ARTICLE CODE	129378	VERSION	10.07.2019 12:59

PROJECT: L524-L546\_StueIV\_7\_Serie

REPLACEMENT FOR DRAWN DATE 10.07.2019 12:59

CONFIDENTIAL INSPECTED TECHNICAL REFEREE

0

1

2

3

4

5

6

7

8

A

B

C

D

E

F

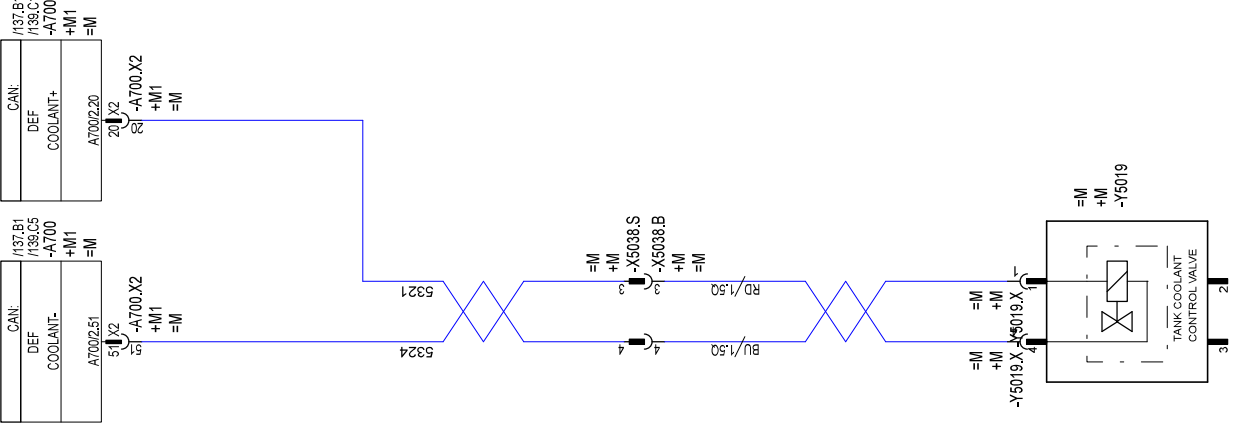

REPLACEMENT FOR	DATE	ARTICLE CODE	SYSTEM	PLACE
DRAWN	10.07.2019 12:59	12939726		
INSPECTED		DRAWING NUMBER	INDEX	SHEET 136 FROM 149
TECHNICAL REFEREE		1560 00190 01 00	200	ARTICLE CODE 1001076 VERBODEN 10.07.2019 12:59

DESCRIPTION  
ENGINE ENVIRONMENT

DESIGNATION  
E PLAN

**LIEBHERR**  
**A3**  
FACTORY LBH

CONFIDENTIAL

INSPECTED

10.07.2019 12:59

**A3**

DESIGNATION  
E PLAN

DESCRIPTION  
ENGINE ENVIRONMENT



LED 1	LED 2	Status	Description
On	On	LED test	Directly after the central control unit is switched on, an LED self-test is executed.
Off	Off	Booting	The system is started and waits for all conditions to be met (such as the presence of CAN modules in the system).
Flashes (at 1 s intervals)	Off	Running	The system is running completely (normal operation).
Off	Flashes (at 0.2 s intervals)	Critical	The entire control system was shut down due to a critical error. The machine software was stopped and the machine can not be operated.
Flashes (at 1 s intervals) alternately with LED 2	Flashes (at 1 s intervals) alternately with LED 1	CAN download	Required software is being downloaded on a CAN module. The machine software has not yet been started. The machine can not yet be operated.

Tab. 266: Function of LEDs 1 and 2

### 2.3 Memory card



Fig. 513: 128 MB memory card

- |          |                            |          |                                   |
|----------|----------------------------|----------|-----------------------------------|
| <b>1</b> | 128 MB memory card         | <b>3</b> | INDEX - current software version  |
| <b>2</b> | Machine software item code | <b>4</b> | Creation date of machine software |

Every time it is started up (when the ignition is switched on) the machine software on the memory card in slot CF1 is tested. If there are any changes, the software is updated.

The data on the memory card takes priority. The system can not be operated without a memory card.

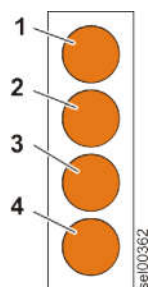

Fig. 514: Memory card status display

LBH/12204898/11/21+20190801\_073806/en

1.1.1 Function of the fuse test

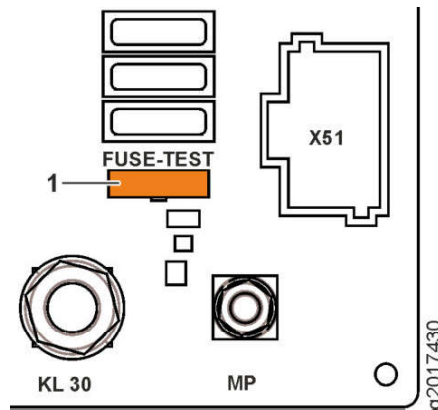

Fig. 523: Function of the fuse test

1 Socket for fuse test

On the top right, the fuse and relay board A4 has a socket 1 for testing the fuses.

To test a fuse, it must be plugged into the socket.

The LED lights up if the fuse is intact.

The fuse test cannot tell whether a fuse has the correct rating. The fuse rating must be checked using the electrical diagram.

1.1.2 Working headlight safety functions

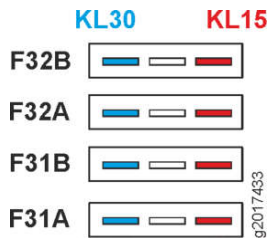

Fig. 524: Working headlight safety functions

Fuse	Function	Fuse	Function
F31A	Front left working headlight	F32A	Rear left working headlight
F31B	Front right working headlight	F32B	Rear right working headlight

Tab. 273: Fuses

The function of the working headlights can be selected by connecting the fuses F31A, F31B, F32A and F32B:

- When the fuses are connected to terminal 30, the working headlights already function when the battery main switch is switched on.
- When the fuses are connected to terminal 15, the working headlights do not function until the ignition is switched on.

A mixed function is also possible, for example with the front working headlights on terminal 15 and the rear working headlights on terminal 30.

LBH/12204898/11/21+20190801\_073806/en

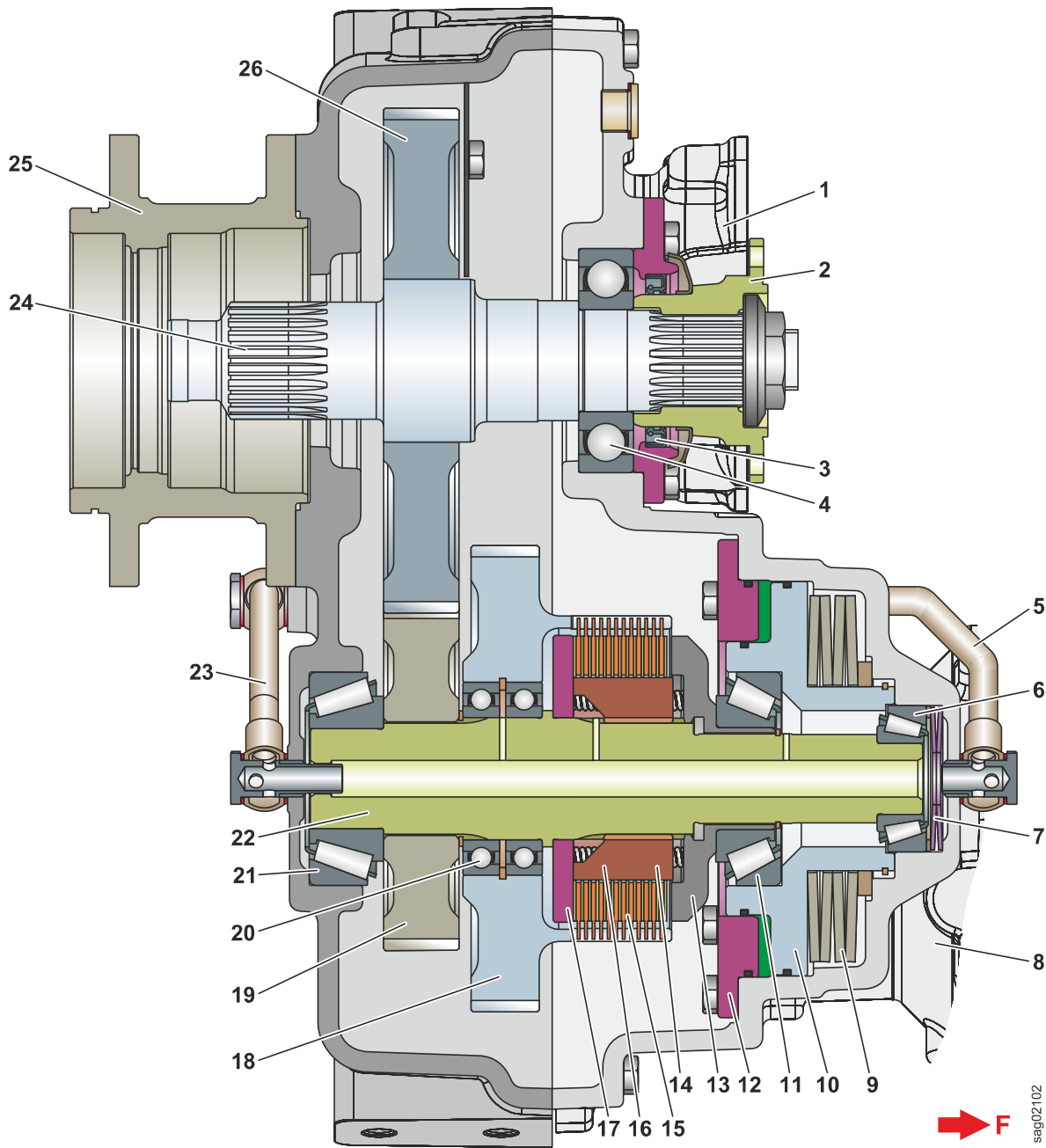

Fig. 533: Transmission: sectional view (from below) (3rd gear engaged)

- |                             |                                  |                            |
|-----------------------------|----------------------------------|----------------------------|
| 1 Flange for travel motor 1 | 10 Clutch piston                 | 19 Intermediate gearwheel  |
| 2 Flange for drive shaft    | 11 Roller bearing                | 20 Ball bearing            |
| 3 Shaft seal ring           | 12 Separator plate               | 21 Roller bearing          |
| 4 Ball bearing              | 13 Pressure piston               | 22 Intermediate shaft      |
| 5 Lubricating line          | 14 Coupling hub                  | 23 Lubricating line        |
| 6 Roller bearing            | 15 Coupling discs                | 24 Output shaft            |
| 7 Cup springs               | 16 Pressure piston return spring | 25 Flange for rear axle    |
| 8 Flange for travel motor 2 | 17 Pressure plate                | 26 Output gear             |
| 9 Clutch cup spring         | 18 Gearwheel with clutch cage    | F Forward travel direction |

LBH/12204898/11/21+20190801\_073806/en

sag02102

Travel ranges	Component	Status
Automatic travel range 1-3	Travel range 1 solenoid (travel motor 1) <b>Y58</b>	De-energised up to a certain speed. Energised for a certain speed range, once travel motor 2 is disengaged.
	Servo pressure proportional solenoid (travel motor 2) <b>Y57</b>	Current at proportional solenoid decreases with increasing speed. Current drops to zero when the travel motor is disengaged.
	Proportional solenoid for clutch <b>Y60</b>	Energised up to a certain speed (travel motor 2 engaged). De-energised starting from a certain speed (travel motor 2 disengaged).

Tab. 291: Travel ranges

## 2.3 Shifting the clutch

### 2.3.1 Opening the clutch

To open the clutch, the central control unit cuts off the current to the gear shifting proportional solenoid Y60. Oil flows from the replenishing pump into the clutch and opens it.

### 2.3.2 Closing the clutch

The clutch closes in two distinct phases

- Rapid draining phase
- Modulation phase

The rapid draining phase enables the clutch to overcome its idle path as quickly as possible. During the rapid draining phase, the central control unit provides the gear shifting proportional solenoid Y60 with maximum current. A large quantity of oil flows out of clutch very quickly.

The modulation phase begins. The central control unit reduces the current to the gear shifting proportional solenoid. The oil flows out of clutch more slowly and the clutch closes gently.

1.2 seconds after gear shifting has begun, the central control unit energises the gear shifting proportional solenoid Y60 with the maximum current again to prevent the clutch from grinding and ensure a positive connection.

The length of rapid draining phase affects how the transmission shifts gears. If the rapid draining phase is too long, the clutch closes too quickly and a jolt can be felt. If the rapid draining phase is too short, the modulation phase is longer, which increases the wear on the clutch. Also, if the rapid draining phase is too short, there can also be a jolt when shifting gears because the central control unit completely closes the clutch at the latest 1.2 seconds after starting the gear shift.

The length of rapid draining phase depends on the hydraulic oil temperature and can be adjusted if shifting is poor.

The current strength for the modulation phase is determined when calibrating the clutch.

# 140 Steel parts of the basic machine

## Contents

140.1	Vehicle frame	140-2
140.1.1	Articulation bearing <i>L538-1559;</i>	140-2
140.1.2	Articulation lock <i>L538-1559;</i>	140-3

**2 Function**

With the quick coupler, the working attachment can be attached and removed without additional tools.

**150.3.2 Quick coupler hydraulics**

**150.3.2.1 Overview of quick coupler hydraulics**

Valid for: L538-1559/0-45466;

**1 Layout**

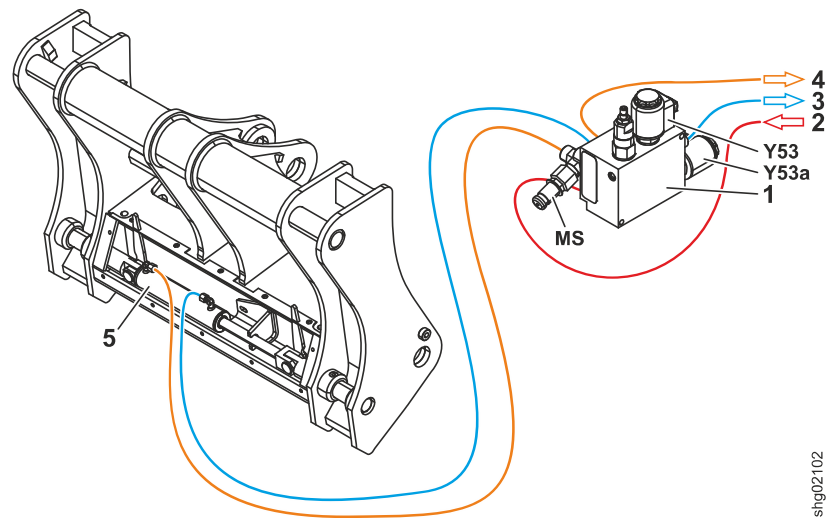

Fig. 552: Overview of the quick coupler hydraulics (from front left)

- |   |   |
|---|---|
| <b>1</b> Valve block for quick coupler                          | <b>4</b> Load sensing signal for working pump (via control valve block) |
| <b>2</b> Oil supply from working pump (via control valve block) | <b>5</b> Hydraulic cylinder for locking quick coupler                   |
| <b>3</b> Return flow to control valve block                     |   |

Name	Test point
MS	Quick coupler closing pressure

Tab. 300: Test points

BMK	Function	BMK	Function
Y53	Solenoid for opening quick coupler	Y53a	Quick coupler load sensing signal solenoid

Tab. 301: Equipment codes

The quick coupler hydraulics consist of the following components:

- Valve block for quick coupler (For more information see: [Valve block for quick coupler, page 150-13](#))
- Hydraulic cylinder for locking quick coupler

LBH/12204898/11/21+20190801\_073806/en

### 1.3 Locking the quick coupler

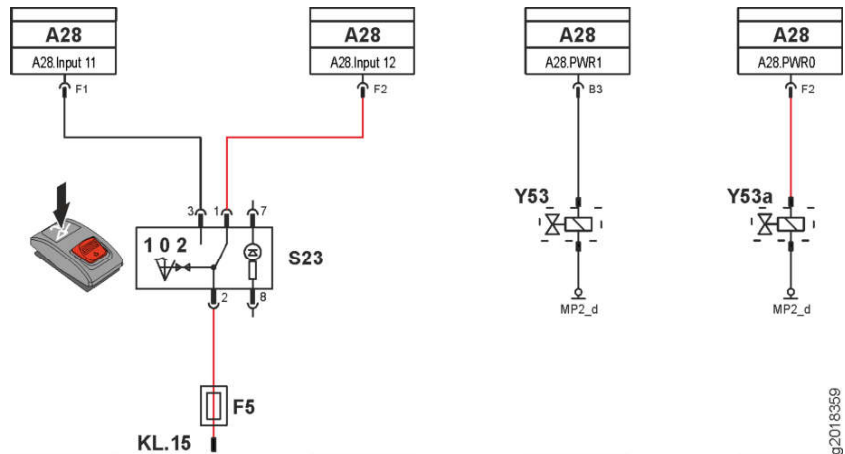

Fig. 562: Button S23 in quick coupler locking position

Position	Description	Position	Description
A28	Compact module A28	Y53	Quick coupler solenoid valve
F5	Quick coupler fuse	Y53a	Quick coupler load sensing signal solenoid valve
S23	Quick coupler button		

Tab. 318: Items

When the *quick coupler* button **S23** is in position **2**, the quick coupler is locked.

The *quick coupler* button **S23** sends an input signal to the compact module **A28**.

The compact module is controlled by the central control unit.

Using the compact module **A28**, the quick coupler load-sensing solenoid valve **Y53a** is activated. At the same time, the quick coupler latching function is deactivated.

The active quick coupler load sensing signal solenoid valve **Y53a** generates pressure from the working pump.

The quick coupler solenoid valve **Y53** quickly returns to its initial position. This locks the quick coupler.

The output for the quick coupler load-sensing signal solenoid valve **Y53a** is only active when the *quick coupler* button **S23** is pushed.

LBH/12204698/11/21+20190601\_073606/en

## 160.2.3 Control lever

Valid for: L538-1559;

### 1 Layout

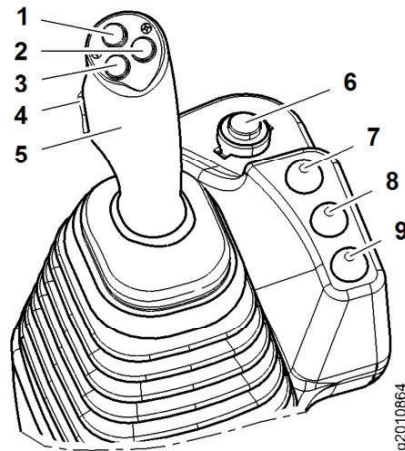

Fig. 568: Control lever

- |   |                         |   |                   |
|---|-------------------------|---|-------------------|
| 1 | Button                  | 6 | Starter switch S1 |
| 2 | Button                  | 7 | Button            |
| 3 | Button                  | 8 | Button            |
| 4 | Travel direction switch | 9 | Button            |
| 5 | Control lever A26       |   |                   |

The control lever (A26) **5** includes the *travel direction* switch **4** and buttons for other functions.

The buttons for additional functions are located on the side of the control lever.

CLICK HERE TO **DOWNLOAD** THE COMPLETE MANUAL

- Thank you very much for reading the preview of the manual.
- You can download the complete manual from: [www.heydownloads.com](http://www.heydownloads.com) by clicking the link below



- Please note: If there is no response to CLICKING the link, please download this PDF first and then click on it.

CLICK HERE TO **DOWNLOAD** THE COMPLETE MANUAL