

en

Service manual

Wheel loader

Document ID

Order number: 12204903
Issued: 2021-10-19
Version: 13
Author: LBH / Technical Documentation Department

Product ID

Manufacturer: Liebherr-Werk Bischofshofen GmbH
Valid for: L 518-1655

Contact

Liebherr-Werk Bischofshofen GmbH
Dr. Hans Liebherr-Straße 4
A – 5500 Bischofshofen

CLICK HERE TO **DOWNLOAD** THE COMPLETE MANUAL

- Thank you very much for reading the preview of the manual.
- You can download the complete manual from: www.heydownloads.com by clicking the link below



- Please note: If there is no response to CLICKING the link, please download this PDF first and then click on it.

CLICK HERE TO **DOWNLOAD** THE COMPLETE MANUAL

030.3.3	Converting hydraulic system from mineral oils to biodegradable hydraulic fluids	030-17
030.3.4	Diesel fuels <i>L518-1655/0-57748;</i>	030-17
030.3.4.1	Minimum quality requirement	030-17
030.3.4.2	Operating temperatures of diesel fuels	030-17
030.3.4.3	Minimum quality requirement	030-18
030.3.5	Diesel fuels <i>L518-1655/57749-;</i>	030-18
030.3.5.1	Minimum quality requirement	030-18
030.3.5.2	Operating temperatures of diesel fuels	030-18
030.3.5.3	Minimum quality requirement	030-18
030.3.6	Diesel exhaust fluid <i>L518-1655;</i>	030-19
030.3.6.1	Liebherr recommendation	030-19
030.3.6.2	Minimum quality requirement	030-19
030.3.7	Engine oils <i>L518-1655;</i>	030-19
030.3.7.1	Liebherr recommendation	030-19
030.3.7.3	Minimum quality requirement	030-19
030.3.8	Refrigerant <i>L518-1655;</i>	030-20
030.3.9	Coolant <i>L518-1655;</i>	030-20
030.3.9.1	Requirements for the water used	030-20
030.3.9.2	Antifreeze and corrosion inhibitor	030-20
030.3.9.3	Minimum quality requirement	030-21
030.3.10	Hydraulic oil <i>L518-1655;</i>	030-21
030.3.10.1	Liebherr recommendation	030-21
030.3.10.2	Minimum quality requirement	030-21
030.3.10.3	Oil analysis	030-22
030.3.10.4	Oil change	030-22
030.3.11	Transmission <i>L518-1655;</i>	030-22
030.3.11.1	Liebherr recommendation	030-22
030.3.11.2	Minimum quality requirement	030-23
030.3.12	Axle oil <i>L518-1655;</i>	030-23

060.4	Control block <i>L518-1655;</i>	060-15
060.5	Pilot control	060-26
060.5.1	Overview of pilot control unit <i>L518-1655;</i>	060-27
060.5.2	Pilot control unit <i>L518-1655;</i>	060-31
060.5.3	Pilot pressure for solenoid valve <i>L518-1655;</i>	060-33
060.6	Ride control	060-35
060.6.1	Overview of ride control system <i>L518-1655;</i>	060-35
060.6.2	Stabilisation module <i>L518-1655;</i>	060-39
060.7	Pipe break protection	060-44
060.7.1	Pipe break protection: overview <i>L518-1655;</i>	060-44
060.7.2	Valve block for pipe break protection <i>L518-1655;</i>	060-46
060.7.3	Ride control release solenoid valve <i>L518-1655;</i>	060-47

070 Travel hydraulics 070-1

070.1	Overview of travel hydraulics <i>L518-1655/0-57748;</i>	070-2
070.2	Overview of travel hydraulics <i>L518-1655/57749-;</i>	070-7
070.3	Travel pump <i>L518-1655;</i>	070-12
070.4	Travel motors	070-27
070.4.1	Travel motor <i>L518-1655;</i>	070-27

080 Hydraulic components 080-1

080.1	Hydraulic system: overview <i>L518-1655/0-57748;</i>	080-2
080.2	Hydraulic system: overview <i>L518-1655/57749-;</i>	080-5
080.3	Hydraulic tank	080-8
080.3.1	Overview of hydraulic tank <i>L518-1655/0-57748;</i>	080-8
080.3.2	Overview of hydraulic tank <i>L518-1655/57749-;</i>	080-10

Symbol	Meaning
—	List Identifies individual items of a list.

Tab. 3: Symbols

010.1.2 Intended use

010.1.2.1 Laws, rules, guidelines and safety regulations

To ensure safe operation:

- Ask work site manager for safety regulations at place of use.
- Adhere to safety regulations at place of use.
- Adhere to traffic regulations.
- Adhere to valid guidelines from insurers (for example employers' professional liability insurance companies, accident insurance et cetera).
- Avoid working methods that can endanger safety.
- Adhere to all intervals specified for recurrent checks and inspections in this operator's manual.

010.1.2.2 Intended use

Wheel loader is used to pick up, move and dump following materials:

- Soil
- Stones
- Broken rocks
- Bulk materials

This applies to a standard machine in normal operating conditions. Special applications are described in a separate options operator's manual.

To ensure intended use:

- Adhere to operator's manual.
- Adhere to maintenance intervals.
- Observe inspection and maintenance tasks.
- Adhere to specifications in the technical data.
- When using machine on public roads, make sure it complies with applicable national regulations.
- Only lift loads with intended working attachments (fork prongs, crane boom), which must be fitted and functioning.
- Make sure that machines used underground (mining and tunnel construction) are fitted with systems to reduce exhaust emissions (such as diesel particulate filters).
- Adhere to individual country's requirements for underground operation.
- For special uses use special working attachments and if necessary special safety equipment.
- Exclusively mount and use special working attachments with approval and as per stipulations of manufacturer of basic machine.
- Only use approved tyres.
- A suitably equipped workshop is absolutely essential for performing repair work.



Note

- ▶ Any other use or use beyond the stated use is improper use.

010.1.6.3 Transporting machine

Danger to life

Machine tipping

- Make sure that the transport vehicle is authorised for the machine weight and machine size.
- Do not manoeuvre while driving on ramps.
- Before driving on ramps, clean mud, snow and ice off tyres or travel gear.
- Make sure that a spotter is available if necessary.
- To load and unload machine, use only sturdy, stable loading ramps.
- Make sure that width and angle of ramps match the gauge and climbing ability of machine.

Incorrect transport

- Park machine on level ground during preparation for transport (disassembly, cleaning).
- Secure machine against rolling away.
- Apply parking brake.
- Pull out ignition key.
- Leave operator's cab.
- All doors, windows and service access points are closed.
- Make sure that nobody is on the machine during transport.
- If necessary, dismantle a portion of working attachment from machine for duration of transport.
- Make sure that the road to be travelled is known.
- Make sure that all applicable limitations for width, height and weight are known.
- Drive carefully under electric cables and bridges.
- Drive carefully through tunnels.

010.1.6.4 Access to machine

Injury





Incorrect entry and exit

- Clean dirt, oil, ice and snow from steps, ladders, anti-slip mats, handrails and handles.
- Enter and exit carefully on muddy roads, ice, snow, traffic on access roads and in narrow conditions.
- Regularly check steps, ladders, anti-slip mats, handrails and handles and have them repaired if necessary.
- Before entering machine, clean mud, grease, ice and snow from shoes and climbing aids.
- Put on gloves for secure grip.
- Do not climb up or down using tyres, wheel hubs or rims.
- When exterior influences (for example wind) make opening and closing the door more difficult: Always guide door with your hand.
- Make sure that the opened or closed door has engaged properly.
- If the machine is still moving: Do not stand up from the operator's seat.
- Never jump off machine.
- Enter and leave the machine exclusively using the access system.
- Do not use control elements as handles.
- Keep your face towards machine during entry and exit.

Designation	Item code	Remark	Fig.
Diagnostic data lead 3.0 m (Ethernet)	10513200	For Sculi diagnostic software (data connection between central control unit and laptop)	

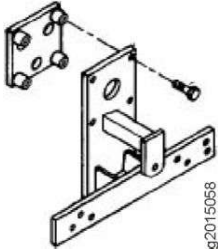
Tab. 4: Special tools, general

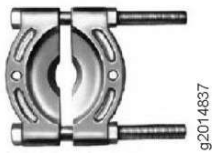
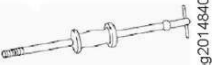
010.2.2 Special tools for the engine

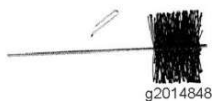
Designation	ID number	Remarks	Fig.:
Engine adapter	10652208	For attaching to an engine cranking device	 g2015068
Spring tension tester	7090992	For checking the tension of the valve springs For checking the spring force of the oil pressure control valve	 g2014830
Extractor	7091003	For removing the crankshaft gear from the crankshaft.	 g2014834
Extractor attachment	7091002	For removing the crankshaft gear from the crankshaft	 g2014837
Punch extractor	12205221	For removing the crankshaft bearing cover For removing the cylinder bushings	 g2014840
Cooling system pressure pump	7091005	For testing the pressure of the cooler cover and cooling system.	 g2014843
O-ring groove cleaning brush	12205227	For cleaning the O-ring groove of the cylinder bushing in the block.	 g2014848

LBH/12204903/13/211-20211019_135819/en

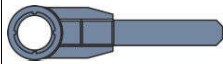
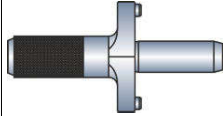
Designation	Item code	Remark	Fig.
Slotted nut spanner	10220626	For removing and installing the bevel gear shaft	
Slotted nut spanner	10220633	For removing and installing the differential	

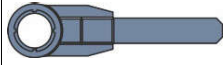
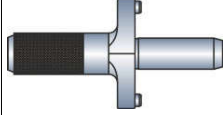

Tab. 15: Special tools for front axle

010.2.13 Special tools for rear axle

Designation	Item code	Remark	Fig.
Set of 5 spanners	10220617	For gripping while removing and installing the bevel gear shaft	
Slotted nut spanner	10220626	For removing and installing the bevel gear shaft	
Slotted nut spanner	10220633	For removing and installing the differential	

Tab. 16: Special tools for rear axle

010.2.14 Special tools for air conditioning system

Designation	Item code	Remark	Fig.
Valve insert remover	11834779	For changing valve inserts in the filling port of air conditioning hoses.	
Valve insert in air conditioning hose filling port	11834778	For replacing defective valve inserts.	
Vacuum pump	7027552	For evacuating the air conditioning system	

LBH/12204903/13/211-20211019_135919/en

state of the art and practical experience, the friction values for the various coatings are complied with for small bolt diameters.

010.3.2 Liebherr standards for assembly instructions and tightening torques

Liebherr standards for assembly instructions and tightening torques for hydraulic cylinders are stored in Liebherr service documentation.

Storage location: Genearl – Liebherr standards

020.1 Overall machine

020.1.1 Complete machine with bucket (z-bar kinematics)

Valid for: L518-1655;

The values stated refer to the machine:

- In its standard version
- With 17.5R25 L3 tyres (For more information see: 020.11.6 Tyres, page 020-28)
- Including all lubricants
- With a full fuel tank
- With ROPS/FOPS cab and operator
- on level and stable ground



Note

Tyres and working attachment affect operating weight and tip load.

► Note the information about the tyres and working attachment.

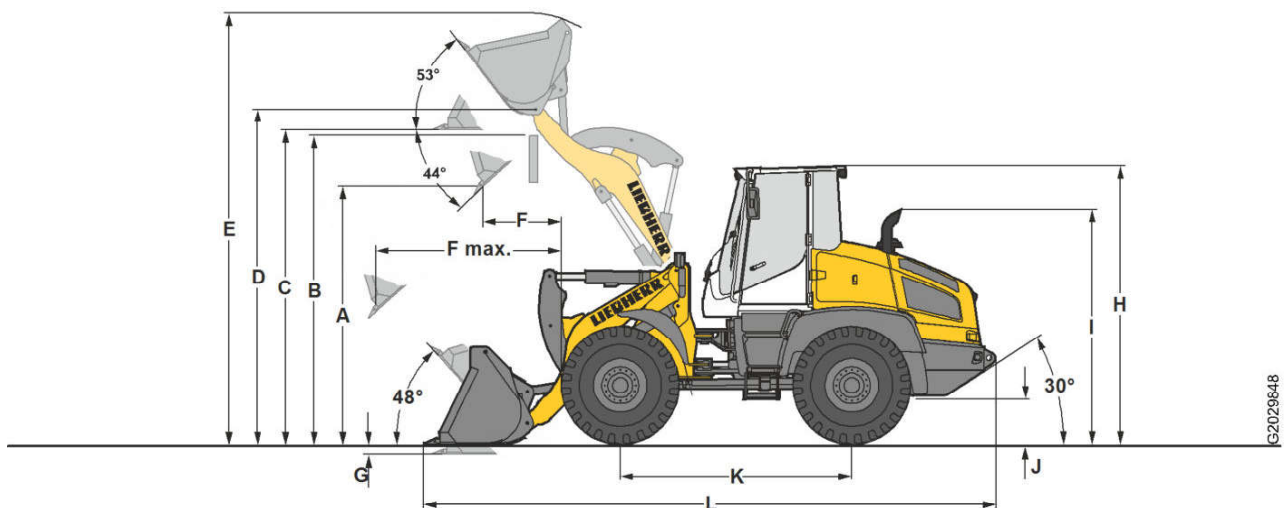

Fig. 82: Complete machine with bucket (Z kinematics)

LBH/12204903/13/211-20211019_135919/en

Designation	Unit	Value		
Hydraulic quick coupler		No	Yes	Yes
Bucket type		A)	A)	A)
Cutting tool		B)	B)	B)
Lift arm length	mm	2400 C)	2400 C)	2645 D)
Bucket capacity as per ISO 7546 E)	m ³	1.7	1.5	1.4
Bucket width	mm	2400	2400	2400
Bucket weight	kg	655	565	590
Specific material weight	t/m ³	1.8	1.8	1.6

020.4 Working hydraulics

020.4.1 Working pump

Valid for: L518-1655;

Description	Unit	Value
Type		KP30.43D0
Direction of rotation		Clockwise
Displacement per turn	cm ³	44
Maximum displacement	l/min	107
Weight	kg	16.8

020.4.2 Control block

Valid for: L518-1655;

Description	Unit	Value
Type		HDS24/4K01
Maximum flow rate for lift function	l/min	120
Maximum flow rate for lowering function	l/min	120
Maximum flow rate for tilt-in function	l/min	90
Maximum flow rate for tilt-out function	l/min	70
Maximum flow rate for 1st additional function A3 (option)	l/min	80
Maximum flow rate for 1st additional function B3 (option)	l/min	80
Maximum flow rate for 2nd additional function A4 (option)	l/min	80
Maximum flow rate for 2nd additional function B4 (option)	l/min	80
Weight (excluding additional spool valve)	kg	35

020.4.3 Pilot control unit

Valid for: L518-1655;

Description	Unit	Value
Type		HC-RCL
Weight	kg	3

020.9.4 Battery

Valid for: L518-1655;

Description	Unit	Value
Battery voltage	V	12
Battery capacity	Ah	100
Acid density of charged battery	kg/l	1.28
Charging current (recommended)	A	10
Charging voltage (recommended)	VDC	14.0 – 14.4
Cold start current (EN)	A	760
Self-discharging (at 25 °C)		About 7% a month
Electrolyte		Diluted sulphuric acid
Top-up water		Distilled or demineralised (DIN 43530)
Number of batteries		2

020.9.5 Voltage transformer

Valid for: L518-1655;

Description	Unit	Value
Input voltage	VDC	12
Output voltage	VDC	24
Output current	A	3
Output power	W	72

020.9.6 Reversing camera

Valid for: L518-1655;

Description	Unit	Value
Rated voltage	VDC	24
Rated current at 24 V (without heating)	A	0.09
Operating temperature	°C	-40 to +70
Resolution	pixels	640 x 480
Protection class		IP6K9K

030 Maintenance

Contents

030.1	Maintenance and inspection schedule	030-10
030.2	Filling quantities and lubrication chart	030-15
030.2.1	Recommended lubricants <i>L518-1655;</i>	030-15
030.2.2	Fuel and operating fluid filling quantity <i>L518-1655;</i>	030-15
030.3	Lubricants and fuels	030-16
030.3.1	General information on lubricants and fuels	030-16
030.3.1.1	General questions	030-16
030.3.1.2	Safety data sheets	030-16
030.3.1.3	Technical data sheets	030-16
030.3.1.4	Specific Liebherr standards	030-16
030.3.2	General information on changing lubricants and fuels	030-16
030.3.3	Converting hydraulic system from mineral oils to biodegradable hydraulic fluids	030-17
030.3.4	Diesel fuels <i>L518-1655/0-57748;</i>	030-17
030.3.5	Diesel fuels <i>L518-1655/57749-;</i>	030-18
030.3.6	Diesel exhaust fluid <i>L518-1655;</i>	030-19
030.3.7	Engine oils <i>L518-1655;</i>	030-19
030.3.8	Refrigerant <i>L518-1655;</i>	030-20
030.3.9	Coolant <i>L518-1655;</i>	030-20
030.3.10	Hydraulic oil <i>L518-1655;</i>	030-21
030.3.11	Transmission <i>L518-1655;</i>	030-22
030.3.12	Axle oil <i>L518-1655;</i>	030-23

Customer:..... Machine type:..... Serial no.:..... Operating hours:..... Date:.....

Maintenance / inspection after service hours							Tasks to be performed				
On handover	All 8-10 h	All 50 h	All 500 h	All 1000 h	All 2000 h	Other intervals	Additional labelling	By maintenance staff	By authorised specialist staff	Confirm tasks	See page
								■ Once-only activity ● Repeat interval † If necessary ✱ Annually before the winter Additional labelling ††† Assistance required ‡ Have this task carried out exclusively by a certified electrician	□ Once-only activity ○ Repeat interval ✧ If necessary		
Overall machine											
<input type="checkbox"/>	●	●	○	○	○			Checking the machine is in the proper condition			030-30
	●	●	○	○	○			Remove loose parts, dirt, ice and snow from machine.			030-32
				○	○			Adjust the machine according to the testing and adjustment check-list.			
				○	○			Corrosion protection system for fittings and electrical contacts (option): Replacing VCI capsules (at least once a year).			030-35
Drive group											
<input type="checkbox"/>	●	●	○	○	○			Checking diesel engine oil level			030-44
			○	○	○			Change the engine oil (at least once a year or according to the engine oil quality and complicating factors). (For more information see: 030.3.7 Engine oils, page 030-19)			030-45
			○	○	○			Change the diesel engine oil filter (with every oil change).			030-47
			○	○	○			Diesel engine: checking V-ribbed belt			030-48
							✧	Change the V-ribbed belt on the diesel engine.			030-50
						○3000 h		Diesel engine: check valve clearance.			030-51
			○	○				Change the diesel engine oil separator filter cartridge.			030-54
			○	○	○			Diesel engine: Check the crankcase bleeder system.			030-55
						○3000 h		Diesel engine: Check the glow plugs.			030-56
<input type="checkbox"/>			○	○	○		†	Drain the condensate and sediment from the fuel tank.			030-57
	●	●	○	○	○			Drain off condensate from the fuel pre-filter.			030-58
			○	○	○			Change the fuel pre-filter element.			030-59
			○	○	○			Change the fuel fine filter element.			030-61
							†	Bleeding the fuel system			030-62
						○4500 h		For emission stage IV machines: exhaust system: replace filter cartridge of diesel exhaust fluid pump (at minimum every 3 years).			030-63
						○5500 h		For emission stage V machines: exhaust system: replace filter cartridge of diesel exhaust fluid pump (at minimum every 3 years).			030-63
						○5500 h		For emission stage V machines: exhaust system: replace filter cartridge of diesel exhaust fluid pre-filter (at minimum every 3 years).			030-64
	●	○	○	○				Clean the service cover and dust discharge valve of the air filter system.			030-66

LBH/12204903/13/211-20211019_135919/en

Type	Designation
Premix ²⁶⁾	Liebherr-Antifreeze OS Mix

Tab. 46: Recommendation for anti-freeze and corrosion protection agent

Ambient temperature	Mixing ratio
Down to -50 °C	40% water 60% antifreeze/corrosion inhibitor
Down to -37 °C	50% water 50% antifreeze/corrosion inhibitor

Tab. 47: Mixing ratio

030.3.9.3 Minimum quality requirement

Specification
ASTM D6210
LH-01-COL

Tab. 48: Specification

In the case of coolants from other manufacturers, it is possible that the service life may differ from the Liebherr recommendation.

Obtain information on the change intervals from manufacturers or suppliers.

030.3.10 Hydraulic oil

Valid for: L518-1655;

030.3.10.1 Liebherr recommendation

Ambient temperature	Designation
	Liebherr mineral oil
From -40 °C to 45 °C	Liebherr Hydraulic HVI
From -10 °C to 45 °C	Liebherr Hydraulic Basic 68
	Liebherr-PAO²⁷⁾ biodegradable
From -25 °C to 45 °C	Liebherr Hydraulic Plus

Tab. 49: Recommendation for hydraulic oils

030.3.10.2 Minimum quality requirement

Specification
EMT LH-00-Minimum-HYE

Tab. 50: Minimum quality requirement

²⁶⁾ Premix = pre-prepared mixture (50% water and 50% antifreeze/corrosion inhibitor)

²⁷⁾ PAO = polyalphaolefin

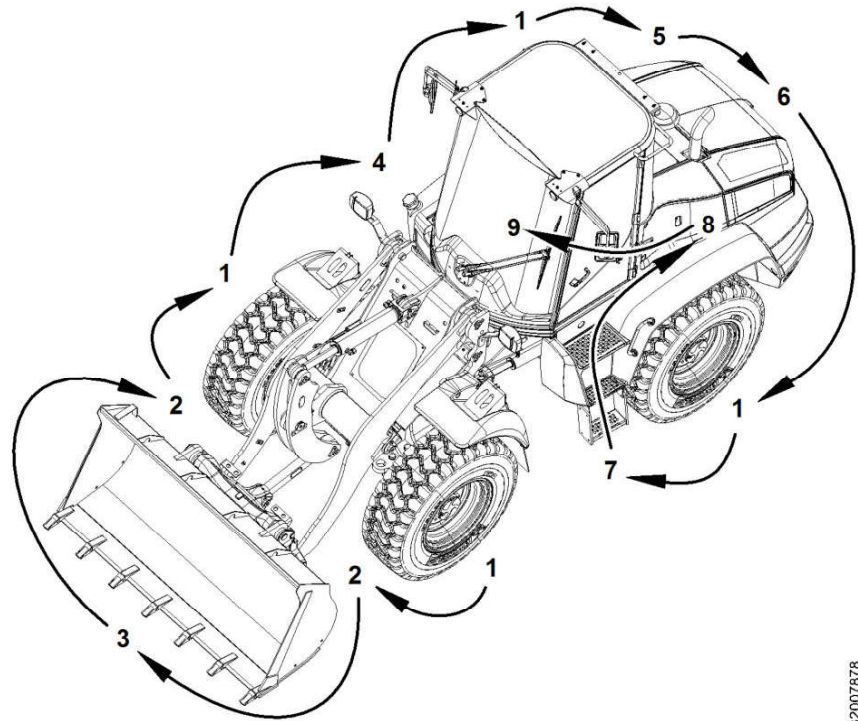

G32007878

Fig. 96: Checking the machine is in the proper condition

► Checking the machine is in the proper condition

If the hydraulic lines are damaged:

► Assess the damage and replace the hydraulic lines if necessary. (For more information see: [Checking the hydraulic lines for damage, page 030-164](#))

Position	Component	Check
1	Tyres	Check the tyres for loose wheel bolts, damage and stones in the tread.
2	Bucket bearings and lift arms	Check that the bucket bearings and lift arms are sufficiently lubricated and free of damage.
3	Working attachment	Check the working attachment for wear and damage.
4	Fuel tank and diesel exhaust fluid tank	Check the fuel tank and diesel exhaust fluid tank for leaks and damage.
5	Cooling system, windscreen washer tank, brake oil equalising reservoir	Check the cooling system for damage and contamination. Check the filling level of the windscreen washer tank and the brake oil equalising reservoir.
6	Underside of machine	Check the underside of the wheel loader for loose bolts, leaks and damage. Check the transmission for leaks and damage.
7	Central lubrication system	Check the grease level in the central lubrication system.
8	Hydraulic oil level	Check the hydraulic oil level.

LBH/12204903/13/211-20211019_135919/en

- | | | | |
|---|-------------------|---|------------------------------------|
| 2 | Ratchet | 7 | Air-conditioning compressor pulley |
| 3 | Alternator pulley | 8 | Water pump pulley |
| 4 | Deflector roller | 9 | Crankshaft pulley |
| 5 | V-ribbed-belt | | |

- ▶ Pull back the tensioning device 1 against the spring force as far as it will go. Take off the V-ribbed belt.
- ▶ Check that the tensioning device and the pulleys are in perfect condition (for example, the tension roller bearings are in place and the pulleys are not worn).
- ▶ With the tensioning device 1 pulled back, fit a new V-ribbed-belt on to the pulleys and return the tensioning device back to the taut position.
- ▶ Put the guard plate back on.
- ▶ Put the fuel pre-filter and the oil filter back on.

030.4.4.6 Diesel engine: checking valve clearance

Valid for: L518-1655;

Make sure the following preconditions are met:

- Machine is in maintenance position 1.
- Service access is open.
- The exhaust system is cold.
- The engine is cold.

Removing the diesel particulate filter and the valve cover

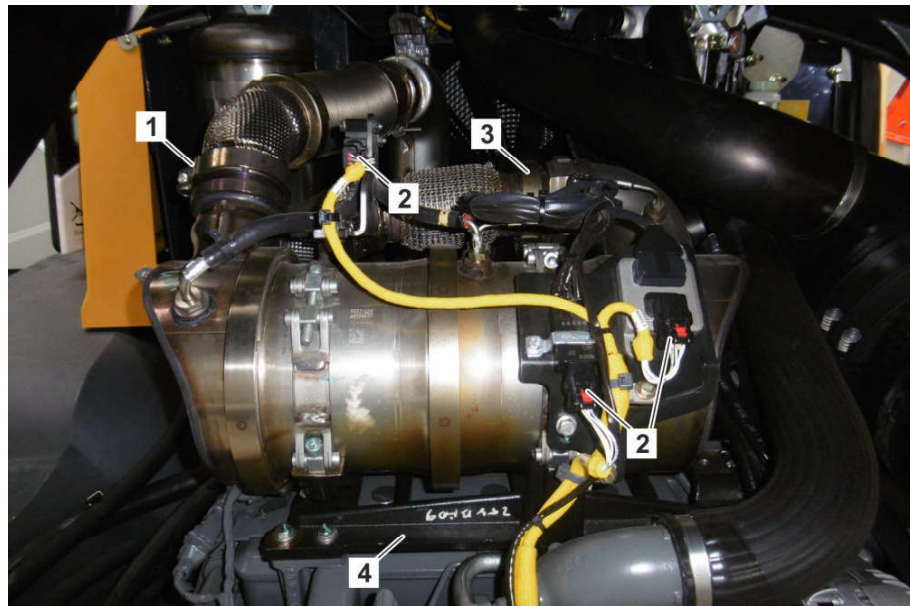

Fig. 114: Removing the diesel particulate filter

- | | | | |
|---|----------------------|---|-------------------|
| 1 | Clip at DPF outlet | 3 | Clip at DPF inlet |
| 2 | Plug connection (2x) | 4 | Mounting plate |

- ▶ Disconnect plug connection 2 of wiring harness.
- ▶ Undo cable ties on wiring harnesses of diesel particulate filter.
- ▶ Release clip at DPF outlet 1.
- ▶ Release clip at DPF in let 3.

- ▶ Plug the electrical connection **3** pack in.
- ▶ Close the bleeder screw **6**.
- ▶ Clean the filter element **5** and the area around it.
- ▶ Bleed the fuel system. (For more information see: [Bleeding the fuel system, page 030-62](#))

030.4.4.13 Changing the fuel fine filter element

Valid for: L518-1655;

Make sure that the following requirements are fulfilled:

- The machine is in maintenance position 1.
- The diesel engine has cooled down.
- The service access is open.

Make sure that the following equipment is ready:

- Receptacle for fuel



WARNING

Highly flammable consumables!
Beware of burns.

- ▶ Avoid naked lights and fire.

NOTICE

If the fuel and operating fluid does not run into the receptacle:
Risk of damage to the engine bearings.

- ▶ Avoid fuel and operating fluid coming into contact with the engine bearings.

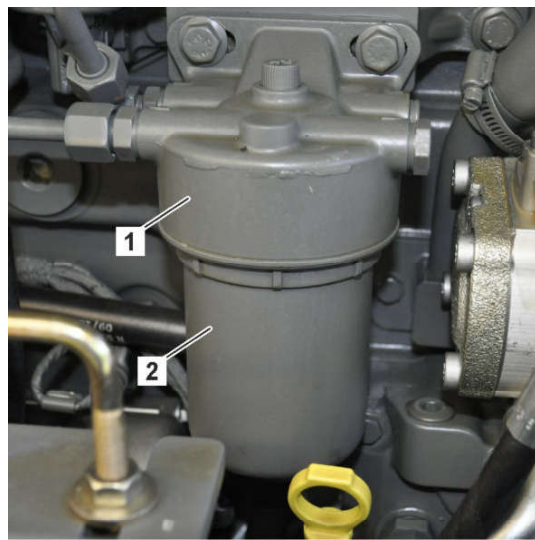

Fig. 124: Changing the fuel fine filter

- | | |
|---------------|------------------|
| 1 Filter base | 2 Filter element |
|---------------|------------------|

- ▶ Carefully clean the filter element **2** and the area around it.
- ▶ Place a receptacle under the filter element **2**.
- ▶ Loosen and remove the filter element **2**.
- ▶ Clean the filter base **1**.

- The service access is open.
- The diesel engine has cooled down.
- Suitable protective equipment is used.

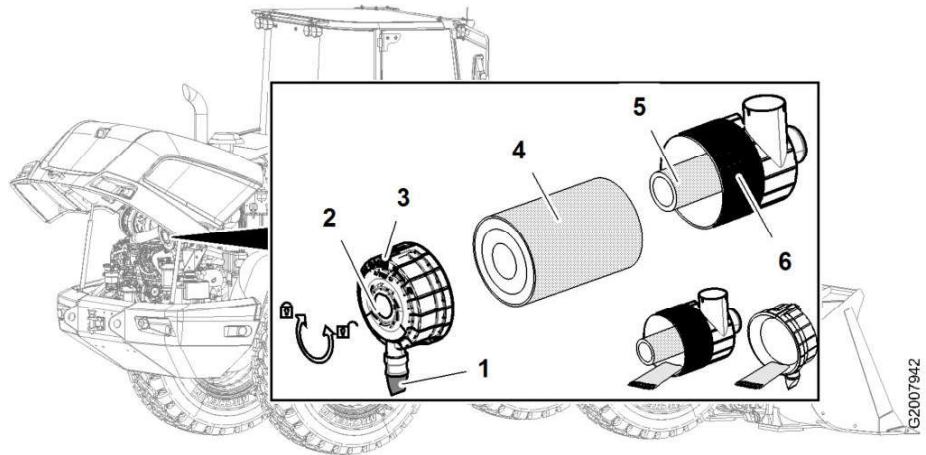

Fig. 136: Changing the air filter safety element

- | | | | |
|---|----------------------|---|----------------|
| 1 | Dust discharge valve | 4 | Main element |
| 2 | Service cover | 5 | Safety element |
| 3 | Locking mechanism | 6 | Filter housing |

- ▶ Release the lock 3 on the service cover 2.
- ▶ Turn the service cover 2 anticlockwise and remove it.
- ▶ Remove the main element 4.
- ▶ Clean the service cover 2 and the filter housing 6 with a clean cloth.
- ▶ Remove the safety element 5.
- ▶ Lightly oil the sealing faces of the new safety element 5 and the main element 4.
- ▶ Install the new safety element 5 and the main element 4.
- ▶ Put the service cover 2, with the dust discharge valve 1 facing down, on the filter housing 6.
- ▶ Turn the service cover 2 clockwise until it catches.
- ▶ Close the lock 3.

030.4.4.20 Checking that diesel engine intake and exhaust system is in good condition and not loose or leaking

Valid for: L518-1655;

Make sure that following requirements are met:

- Machine is in maintenance position 1.
- Diesel engine has cooled down.
- Service access is open.

**Note**

Unless otherwise required by the ambient temperatures:

- ▶ Adjust the freezing point to $-37\text{ }^{\circ}\text{C}$ (50% antifreeze and corrosion inhibitor).

If required value is reached:

- ▶ Close cap of water cooler 1.

If required value is not reached:

- ▶ Determine amount to be topped up and adjust concentration of anti-freeze and corrosion protection agent correctly.

Determining amount to top up

030.4.7 Hydraulic components

030.4.7.1 Checking oil level in hydraulic tank

Valid for: L518-1655;

Checking the oil level

Make sure that following requirements are fulfilled:

- Machine is in maintenance position 1.
- Machine is cold.

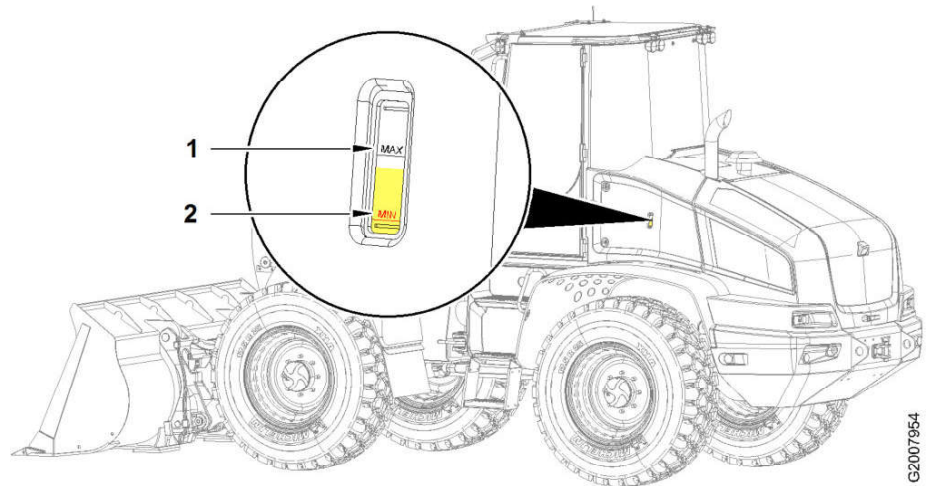

Fig. 156: Checking oil level

1 Maximum oil level

2 Minimum oil level



Note

To check the oil level:

- ▶ Put the machine in maintenance position 1.

- ▶ Check oil level.

▷ The oil level must be between the maximum 1 and minimum 2.

If the oil level is below the minimum 2:

- ▶ Top up with hydraulic oil. (For more information see: [Topping up oil](#), page 030-91)

Troubleshooting

If oil is above maximum level 1:

- ▶ Contact Liebherr customer service.

Topping up oil

Make sure that following requirements are fulfilled:

- Machine is in maintenance position 1.
- Machine is cold.
- Service access is open.
- Suitable climbing aids are available.

Testing the service brake

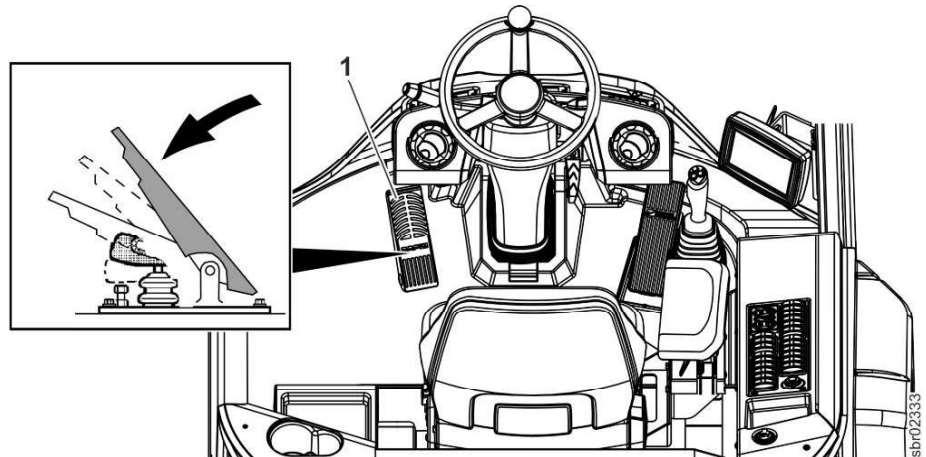

Fig. 165: Testing the service brake

1 Inching brake pedal

- ▶ Start diesel engine.
- ▶ Accelerate machine to approximately 8 km/h.
- ▶ While machine is moving, press inching brake pedal **1** completely.

If the machine does not come to an abrupt stop:

- ▶ Check service brake for damage.
- ▶ Check gap and wear on brake linings. (For more information see: [Checking gap and wear on service brake linings, page 030-104](#))

Testing the parking brake

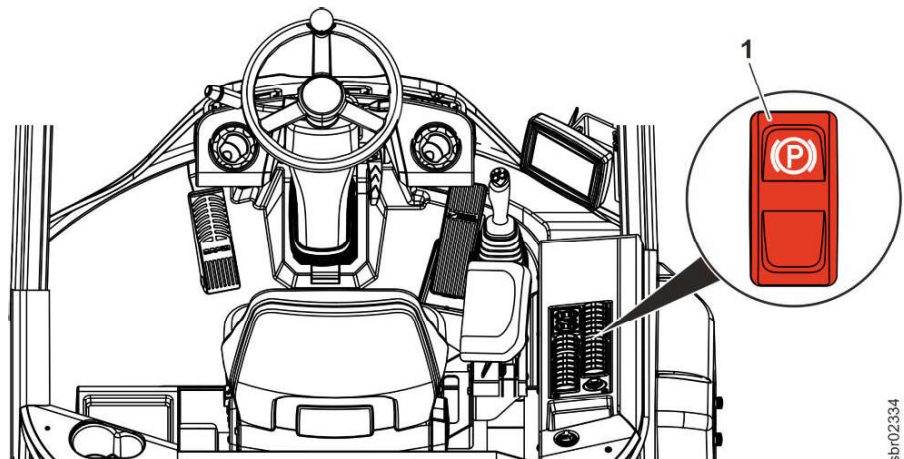

Fig. 166: Testing the parking brake

1 Parking brake button

- ▶ Start diesel engine.
- ▶ Accelerate machine to approximately 5 km/h.
- ▶ Press button **1** while travelling.
 - ▷ The machine must come to an abrupt halt.

If the acid level is too low:

- ▶ Top up with distilled water to 10 mm above the plates.

Checking the charge level

- ▶ Check the charge level with a refractometer.

Charge levels				
Acid density at 27 °C (kg/l)	Charge level	Battery voltage	Voltage per cell	Remark
1.28 to 1.26	100%	over 12.60	over 2.10	Battery OK
1.25 to 1.24	75%	12.54 to 12.40	2.10 to 2.07	
1.24 to 1.18	50%	12.40 to 12.18	2.07 to 2.03	Charge battery
1.18 >	25%	12.18 >	2.03 >	Battery not OK

Tab. 67: Table of charge levels

If the acid density is below 1.24 kg/l:

- ▶ Charge the batteries.

If the acid density is below 1.18 kg/l:

- ▶ Replace the batteries.

030.4.10.3 Use the control lever to change the travel direction switch rocker and cap.

Valid for: L518-1655;

Changing the travel direction switch

Make sure the following preconditions are met:

- Machine is in maintenance position 1.

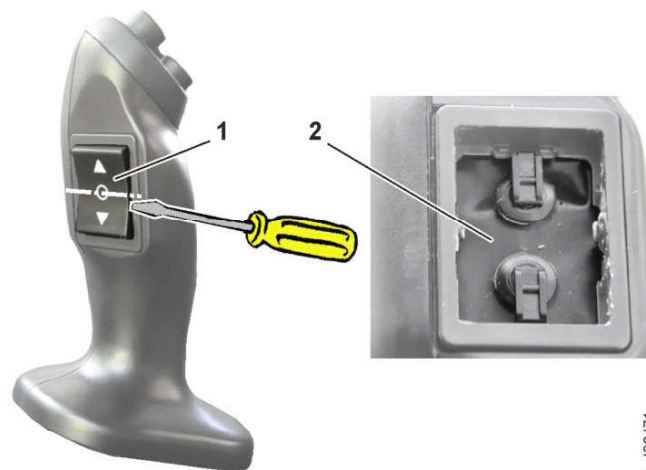

Fig. 176: Changing the travel direction switch

1 Rocker

2 Seal

030.4.12.3 Lubricating rear axle kingpin bearings

Valid for: L518-1655;

Make sure the following preconditions are met:

- Machine is in maintenance position 1.
- The lubricating point has been cleaned.

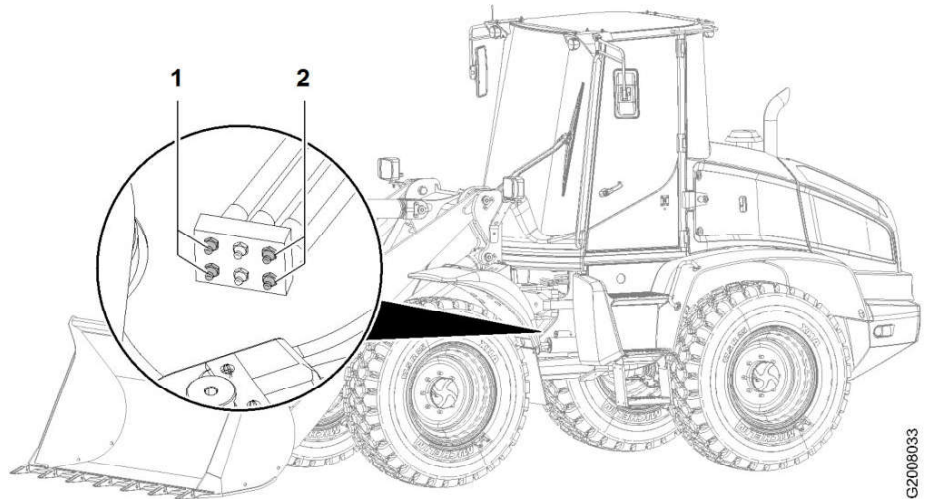

Fig. 185: Lubricating rear axle kingpin bearings

- | | |
|---|--|
| <p>1 Lubrication points on right kingpin bearing</p> | <p>2 Lubrication points on left kingpin bearing</p> |
|---|--|

- ▶ Take cap off grease fitting.
- ▶ Lubricate the kingpin bearing at the lubrication points **1** and **2**.
- ▶ Put cap on grease fitting.

030.4.12.4 Checking the fitting of the rear axle kingpin bearings and steering rod taper connections

Valid for: L518-1655;

Make sure that the following requirements are fulfilled:

- The machine is in maintenance position 1.



Note

Different dimensions for 4in1 bucket!
Incorrect measurement result.

- ▶ Perform test with standard bucket.

Make sure that following requirements are met:

- Machine is secured against rolling away.



Fig. 198: Checking lift arm bucket stops

- 1 Linkage stop
- 2 Bucket stop (2x)

- ▶ Start diesel engine.
- ▶ Raise lift arms half way and support them.
- ▶ Tilt bucket all way out.
- ▶ Turn off diesel engine and take out ignition key.
- ▶ Check that gaps at stops correspond to required value.

Description	Unit	Value
Gap at linkage stop 1	mm	0
Gap at bucket stops 2	mm	4 ±4

If required values are not reached:

- ▶ Contact technical customer service department.

030.4.14.4 Lubricating and testing bearings on quick coupler

Valid for: L518-1655;

This equipment is optional.

Lubricating quick coupler

Make sure the following preconditions are met:

- Machine is in maintenance position 1.
- The lubricating point has been cleaned.
- The working attachment is disconnected for lubricating points near the bucket coupling, which are difficult to access.

LBH/12204903/13/211-20211019_135919/en

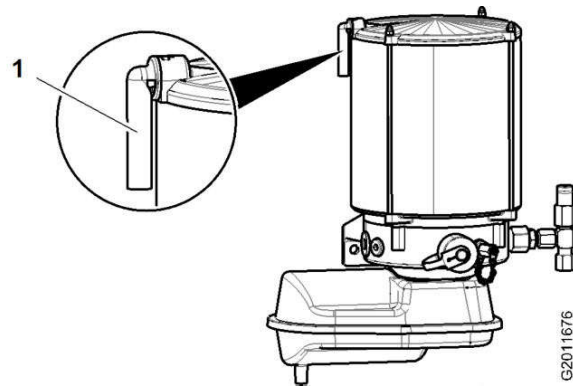

Fig. 209: Central lubrication system: checking pipes, hoses and lubrication points for leaks and damage.

1 Bleeder

- ▶ Check the bleed valve 1 on the central lubrication system for defects.
- ▶ Visually examine all pipes for defects.

If there are defects:

- ▶ Find the cause and rectify it.

030.4.16.3 Central lubrication system: checking lubrication of bearings

Valid for: L518-1655;

This equipment is optional.

Make sure the following preconditions are met:

- Machine is in maintenance position 2.
- ▶ Visually inspect whether metered quantities are adequate at bearing points.

NOTICE

Insufficient lubrication!
Damage to the bearings.

- ▶ Lubricate more often.
-

Checking whether calibration is successful

- ▶ Check whether value *PRInchPdIPos* is correct when inching brake pedal is not pressed, and when it is fully depressed.

Description	Unit	Value
Variable with inching brake pedal not pressed	%	0
Variable with inching brake pedal fully depressed	%	100

If a required value is not reached:

- ▶ Calibrate inching function again.

If a required value is not reached despite repeated calibration:

- ▶ Check basic setting of inching brake pedal. (For more information see: [Inching brake pedal: basic setting, page 030-182](#))
- ▶ Check basic setting of angle sensor for inching function. (For more information see: [Angle sensor for inching function: checking basic setting, page 030-183](#))
- ▶ Calibrate inching function again.

If required values are reached:

- ▶ Calibration was successful. Turn off diesel engine.

030.6.3.2 Diesel engine speed

Valid for: L518-1655;

The engine speed is determined by the engine control unit and cannot be adjusted mechanically.

Make sure that the following requirements are fulfilled:

- The machine is parked on level ground.
- The coolant is at operating temperature.
- ▶ Start the diesel engine.
 - ▷ The display shows the diesel engine speed.
- ▶ Make sure that the parking brake is activated.
- ▶ Check that the diesel engine speeds are correct.

Description	Unit	Value
Lower idling speed	min ⁻¹	800 ^{±10}
Upper idling speed	min ⁻¹	2500 ^{±30}

If a required value is not reached:

- ▶ Perform diesel engine troubleshooting procedure.

030.6.3.3 Reading the diesel engine service files

Valid for: L518-1655;

The data required for the diagnosis of the damage to the diesel engine and for handling warranty claims are referred to as service files.

The service file consists of the following information:

- Information and overview of the control unit in the form of a PDF-Files.
- Load profile of the diesel engine

- ▶ Turn adjusting screw on safety valve **1** half a turn anticlockwise.
 - ▷ Opening pressure of safety valve **1** is below that of LS pressure relief valve.
- ▶ Start diesel engine.
- ▶ Connect Sculi diagnostic software to Machine.
- ▶ In variables editor, select **Ride control** folder.
- ▶ Set variable **QXRideCtrlValve_KG** to **1**.
 - ▷ Ride control is constantly activated.

**Note**

Variable **QXRideCtrlValve_KG** is automatically reset to **0** when ignition is switched **OFF**.

- ▶ If necessary, reset value to **1** when repeating test.

- ▶ Raise lift arms to end position.
- ▶ Fully activate lifting function at low idling speed.
- ▶ While doing so, check whether high pressure **PA** corresponds to specified value.

Description	Unit	Value
High pressure PA	bar	160 ⁺¹⁰

If required value is not reached:

- ▶ Set bucket down with its teeth or cutting edge resting on ground.
- ▶ Turn off diesel engine and take out ignition key.

**Note**

To adjust safety valve:

- ▶ Turning adjusting screw clockwise increases pressure.
- ▶ Turning adjusting screw anticlockwise reduces pressure.

- ▶ Turn adjusting screw of safety valve **1**.
- ▶ Repeat check and adjustment until required value is reached.

If required value is reached:

- ▶ Set bucket down with its teeth or cutting edge resting on ground.
- ▶ Turn off diesel engine and take out ignition key.
- ▶ Turn safety valve **1** exactly half a turn clockwise.

To make sure opening pressure of safety valve **1** is above that of LS pressure relief valve again:

- ▶ Check working hydraulics LS pressure relief valve. (For more information see: [Control valve block: working hydraulics LS pressure relief valve, page 030-158](#))
- ▶ Disconnect pressure gauge from working hydraulics high pressure test connection **PA**.

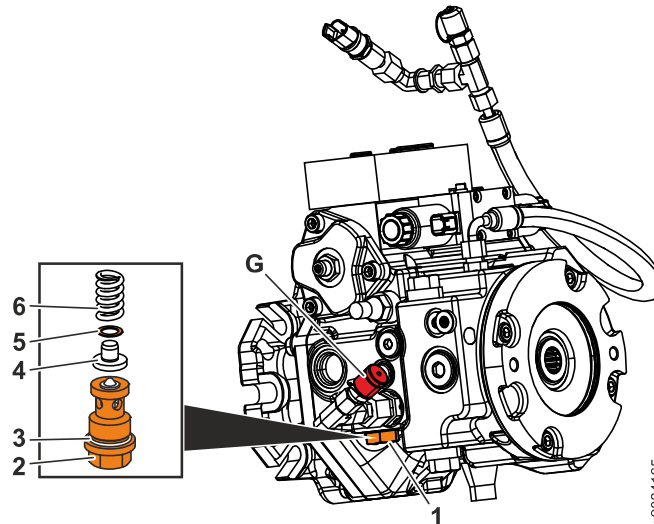

Fig. 231: Travel pump replenishing pressure relief valve

- | | | | |
|---|------------------------------------|---|---------------------------------------|
| 1 | Replenishing pressure relief valve | 5 | Adjusting shim |
| 2 | Screw plug | 6 | Compression spring |
| 3 | O-ring | G | Replenishing pressure test connection |
| 4 | Spring cup | | |

- ▶ Connect a pressure gauge (40 bar) to replenishing pressure test connection **G** on travel pump.
- ▶ Start diesel engine.
- ▶ Increase engine speed to maximum.
- ▶ Check that replenishing pressure **G** corresponds to required value.

Description	Unit	Value
Replenishing pressure G	bar	33 ±3

If required value is not reached:

- ▶ Turn off diesel engine and take out ignition key.
- ▶ Install vacuum pump. (For more information, see Liebherr service documentation on removing and installing components)
- ▶ Place a receptacle under steering pump.



CAUTION

Hot, pressurised fuel and operating fluids!
Beware of burns.

- ▶ Let fuel and operating fluids cool down.
- ▶ Wear safety gloves and safety glasses.

- ▶ Unscrew replenishing pressure relief valve **1**.

If replenishing pressure is too low:

- ▶ Insert adjusting shims **5**.

If replenishing pressure is too high:

- ▶ Remove adjusting shims **5**.

- ▶ Select forward travel direction.
- ▶ Increase diesel engine speed until travel pump high pressure **MH** is 200 bar.
- ▶ Set value of variable **QRDrEPMotor_KG** to 1000 mA.

While maintaining travel pump high pressure **MH** at 200 bar:

- ▶ Click variable **QRDrEPMotor_KG** and press *space bar*.
 - ▷ Line is coloured pink.
 - ▷ A gradual approach towards the required value is possible.



Note

To gradually approach the required value:

- ▶ Cursor *up/down*: last digit of the value +/- 1
- ▶ Cursor *left/right*: last digit of the value +/- 5
- ▶ Page *up/down* button: last digit of the value +/- 10

- ▶ Increase value of variable **QRDrEPMotor_KG** until travel motor servo pressure **M1** is 185 ^{±5} bar.
- ▶ Note set value of variable **QRDrEPMotor_KG**.
- ▶ Increase noted value of variable **QRDrEPMotor_KG** by 20 mA and enter it as value of variable **CRDrEPMot2Imax**.
- ▶ Check whether entered value of variable **CRDrEPMot2Imax** corresponds to required value.

Description	Unit	Value
Required value	mA	1200 ^{±100}

If required value is not reached:

- ▶ Turn off diesel engine and take out ignition key.
- ▶ Adjust travel motor regulation adjusting screw **1**.



Note

To adjust travel motor regulation adjusting screw **1**:

- ▶ If maximum current is too low: turn adjusting screw anticlockwise.
- ▶ If maximum current is too high: turn adjusting screw clockwise.

- ▶ Repeat check and adjustment until required value is reached.

If required value is reached:

- ▶ Turn off diesel engine and take out ignition key.
- ▶ Disconnect pressure gauge from travel motor servo pressure test connection **M1**.
- ▶ Disconnect pressure gauge from travel pump high pressure test connection **MH**.

- ▶ Test the options.
- ▶ Carry out a test drive.

Troubleshooting

If the software update is not successfully completed:

- ▶ Switch off the ignition and wait until all LEDs go out.
 - ▶ Switch on the ignition. The software update is started again.
-

030.6.9.4 Central control unit (Master5): software update

Valid for: L518-1655/60067-;

Machine software is transferred in form of a MSB file (Machine Software Bundle) to central control unit (Master5).

Each MSB file contains machine-specific serial number. As a result, a MSB file can only be transferred to the central control unit (Master5) of machine with corresponding serial number.

MSB file is created via the "MSB Online Tool".

An Internet connection is required for the "MSB Online Tool".

Internet address "MSB Online Tool": <https://www.lidat.liebherr.com/MsbOnline>

**Note**

On machines with XPower gearbox, the version of the machine software must be compatible with the version of transmission software.

- ▶ Ensure that the appropriate software version of transmission software is installed after a machine software update.
-

Creating MSB file

Make sure the following preconditions are met:

- Internet connection is available.
- Corresponding permissions for the "MSB Online Tool" are available.
- ▶ "MSB Online Tool" Open.

- ▶ Connect central control unit (Master5) using Ethernet diagnostic cable with laptop.
- ▶ Switch on ignition.
- ▶ Run the Sculi diagnostic software.

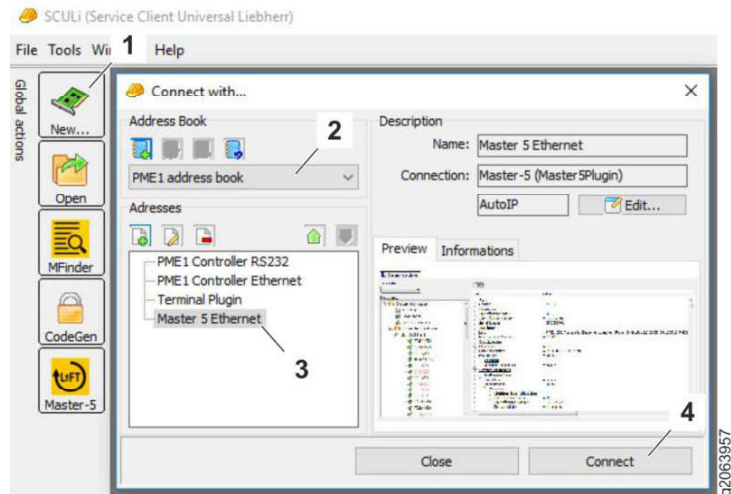

Fig. 264: Connecting Sculi diagnostic software

- | | | | |
|---|-----------------------------------|---|-----------------------------|
| 1 | “New” function | 3 | “Master 5 Ethernet” address |
| 2 | “PME 1 address book” address book | 4 | “Connect” function |

- ▶ Select “New” function 1.
- ▶ Select “PME 1 address book” address book 2.
- ▶ Select “Master 5 Ethernet” address 3.
- ▶ Select “Connect” function 4.
 - ▷ Connection to central control unit (Master5) is established.



Fig. 279: Display with exit button

- ▶ Press *exit* button.
- ▶ Press *exit* button.
 - ▷ The software is uploaded again from the central control unit (Master4). This process can take several minutes.
 - ▷ If the standard screen reappears after uploading, the procedure has been performed successfully.

030.6.11.3 Display (Display5): formatting and reinstalling software

Valid for: L518-1655/52225-;

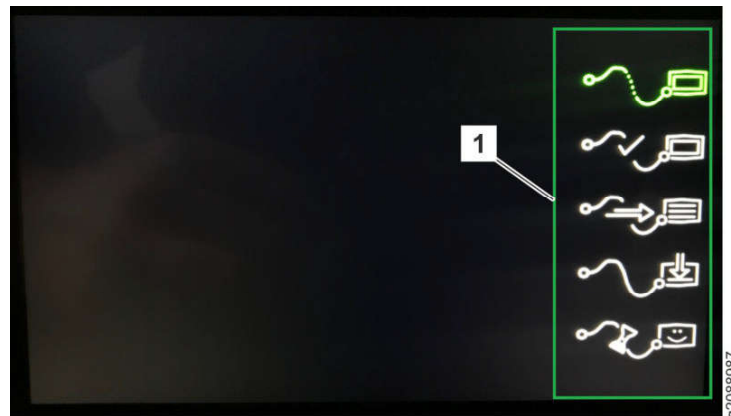

Fig. 280: Opening the display configurator

- 1 Open display configurator key (not visible)

The display configurator is used to format the display and reinstall the software. The display configurator is opened by pressing an invisible key during the boot routine.

- ▶ Switch on the ignition and press the Open display configurator key (not visible) **1** during the boot routine.

040 Drive group

Contents

040.1	Engine	040-2
040.1.1	Diesel engine overview <i>L518-1655;</i>	040-2
040.1.2	Electrical components of the diesel engine <i>L518-1655;</i>	040-6
040.1.3	Fuel system	040-16
040.1.3.1	Overview of the fuel system <i>L518-1655;</i>	040-16
040.1.3.2	Fuel level sensor <i>L518-1655;</i>	040-17
040.1.3.3	Fuel pre-filter <i>L518-1655;</i>	040-19
040.1.3.4	Fuel fine filter <i>L518-1655;</i>	040-20
040.1.4	Air filter system	040-21
040.1.4.1	Air filter <i>L518-1655;</i>	040-21
040.1.5	Exhaust system	040-21
040.1.5.1	Overview of exhaust system <i>L518-1655;</i>	040-22
040.1.5.2	Diesel particulate filter (DPF): overview <i>L518-1655;</i>	040-24
040.1.5.3	SCR system <i>L518-1655;</i>	040-28
040.1.5.4	Sampling module <i>L518-1655;</i>	040-33
040.1.5.5	Diesel exhaust fluid pre-filter <i>L518-1655/57749-;</i>	040-34
040.2	Clutch <i>L518-1655;</i>	040-35

2.6 Intercooler outlet temperature sensor

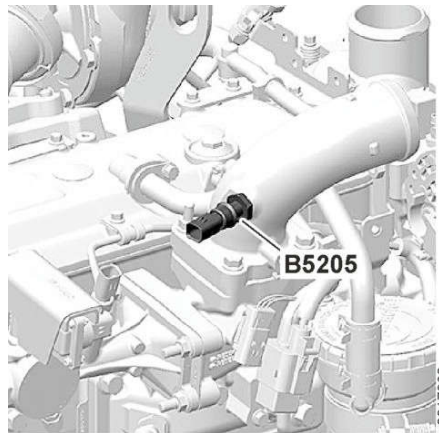

Fig. 305: Intercooler outlet temperature sensor B5205

The engine control unit uses the intercooler outlet temperature sensor **B5205** to measure the intercooler outlet temperature, which enters the intake manifold.

The engine control unit compares the temperature of the recirculated exhaust gases, the intercooler outlet air and the mixed air in the intake manifold to determine whether cooling and mixing has taken place properly.

If the temperature is not right, the engine control unit adjusts the signal to the EGR valve in order to optimise the mixture.

2.7 Manifold air temperature sensor

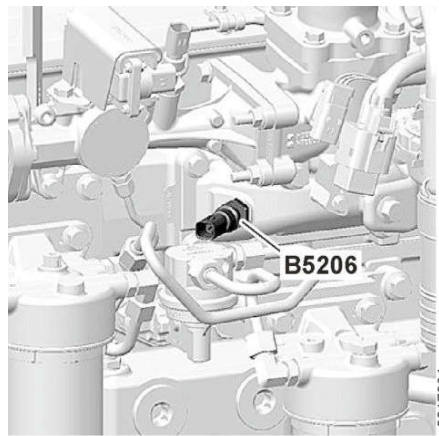

Fig. 306: Manifold air temperature sensor B5206

The engine control unit uses the manifold air temperature sensor **B5206** to measure the air temperature in the intake manifold.

The engine control unit compares the temperature of the recirculated exhaust gases, the intercooler outlet air and the mixed air in the intake manifold to determine whether cooling and mixing has taken place properly.

If the temperature is not right, the engine control unit adjusts the signal to the EGR valve in order to optimise the mixture.

The manifold air temperature sensor helps the engine control unit to calculate the correct fuel supply.

040.1.4 Air filter system

040.1.4.1 Air filter

Valid for: L518-1655;

1 Layout

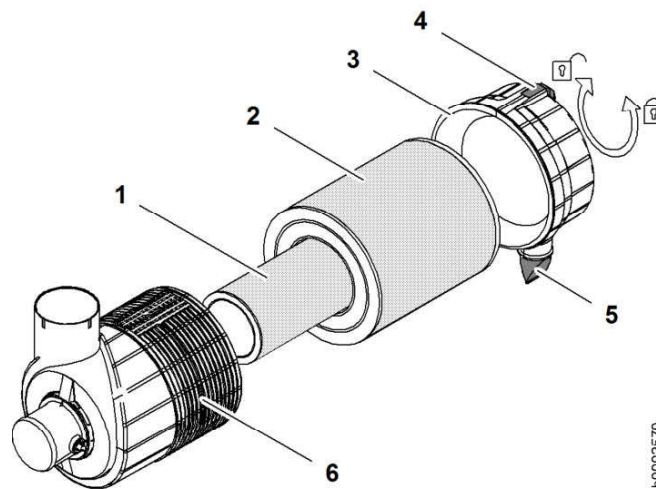

Fig. 320: Layout of air filter

- | | | | |
|---|----------------|---|----------------------|
| 1 | Safety element | 4 | Retaining clips |
| 2 | Main element | 5 | Dust discharge valve |
| 3 | Service cover | 6 | Filter housing |

2 Function

The main element **2** and the safety element **1** must be regularly replaced (see the maintenance and inspection schedule).

The safety element **1** is used as a back-up if the main element **2** is damaged.

The safety element **1** must be replaced after the main element is replaced three times, or as necessary.

The dust discharge valve **5** is used for automatically emptying the dust from the service cover **3**.

The tangential arrangement of the intake port sets the intake air into rotation, where centrifugal force throws the larger dust particles against the housing wall and the flow of intake air deposits them in the service cap **3**.

At idling speed, the collected dust particles in the service cover **3** are blown outside via the dust discharge valve **5** by the pulsations of the intake air.

The service cover **3** must be fitted so that the dust discharge valve **5** points downwards.

When the engine is running (lower idle speed), you should clearly feel air pulsating at the dust discharge valve **5**.

040.1.5 Exhaust system

1.3.1 Backing pumps

When the engine control unit activates the metering pump, the diesel exhaust fluid pump in the metering unit draws diesel exhaust fluid from the diesel exhaust fluid tank. The diesel exhaust fluid is forced through the reverse flow valve and the diesel exhaust fluid filter.

After the diesel exhaust fluid filter, the flow of the diesel exhaust fluid is divided into two separate flows. One flows to the diesel exhaust fluid connection to the diesel exhaust fluid nozzle **5**, the other flows via the diesel exhaust fluid return line connection back to the diesel exhaust fluid tank **4**. A metering opening is installed in the return flow. This ensures that the prescribed pressure is maintained in the system.

1.3.2 Pressure regulation

The pressure sensor is located downstream of the diesel exhaust fluid filter on the return side.

After the diesel exhaust fluid pump has built up sufficient pressure, the motor control unit regulates the pump speed and the function of the reverse flow valve to maintain the desired system pressure.

1.3.3 Shut down sequence

When the starting switch is turned off, the engine control unit opens the diesel exhaust fluid nozzle. At the same time, the reverse flow valve is activated and changes the diesel exhaust fluid flow from the pressure line to the diesel exhaust fluid nozzle to the return line.

The diesel exhaust fluid is thus drawn from the pressure line of the nozzle and returned to the tank through the return line.

1.3.4 Cold environments

The metering unit has a temperature sensor. In cold weather, the engine control unit monitors the diesel exhaust fluid temperature in the system and the temperature of the metering unit. If the temperature is too low, the metering unit heating is activated. This ensures that the diesel exhaust fluid flows through the metering unit even at low outside temperatures.

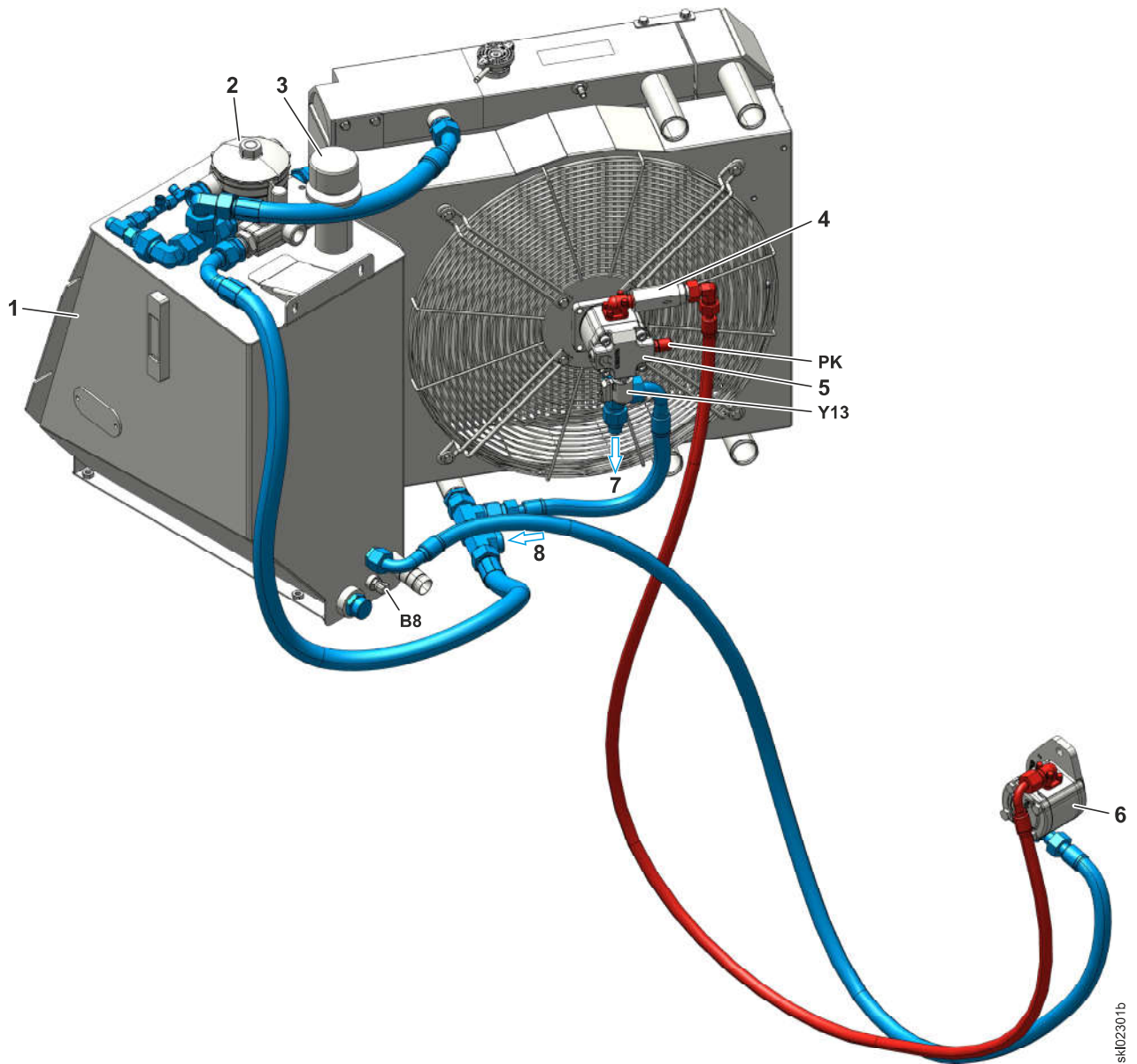

Fig. 336: Cooling system hydraulics (diesel engine is running) (from rear left)

- | | | | | | |
|---|-----------------------|---|----------------------|---|---|
| 1 | Hydraulic tank | 4 | In-line filter 80 µm | 7 | Travel motor housing flushing (cooling) |
| 2 | Return suction filter | 5 | Fan motor | 8 | Leak oil from travel pump |
| 3 | Breather filter | 6 | Fan pump | | |

Name	Test point
PK	Cooling system high pressure

Tab. 87: Test points

BMK	Function	BMK	Function
B8	Hydraulic oil temperature sensor	Y13	Fan speed proportional solenoid

Tab. 88: Equipment codes

LBH/12204903/13/211-20211019_135919/en

2.3 Control characteristics when limits are exceeded

If any of three temperature readings exceeds a predefined limit, the current applied to the fan speed proportional solenoid is reduced to the minimum current standard setting.

Thresholds			
Temperature limits		Current to proportional solenoid	System pressure (at engine speed of 2500 min ⁻¹)
Hydraulic oil	88 °C	Minimum current	175 ^{±10} bar
Coolant	113 °C		
Charge air	80 °C		

Tab. 102: Thresholds

If a limit is exceeded, it has following effects:

- Current applied to proportional solenoid is reduced to minimum level.
- A warning sound goes off.
- A service code is displayed.
- If coolant temperature is too high or charge air temperature is too high, performance of diesel engine is reduced.
- If hydraulic oil temperature is too high, output of travel pump is reduced to as low as 40%.

2.4 Sensor failure

If any of three sensors fails, the fan speed proportional solenoid is operated with the minimum current.

Description	Current at proportional solenoid (standard setting)	System pressure (at engine speed of 2500 min ⁻¹)
Sensor failure	Minimum current	175 ^{±10} bar

Tab. 103: Sensor failure

Minimum current can also be adjusted by means of variable **CRFCFanCurrMin** in Sculi diagnostic software.

2.5 Behaviour with active compressor magnetic coupling

If magnetic coupling for compressor magnetic coupling Y22 is active, maximum current is limited to 600 mA. Increased cooling capacity during air conditioning operation is thus ensured.

2.6 Behaviour of active regeneration of diesel particulate filter

During an active regeneration of diesel particulate filter, maximum current is reduced to 70% of set value. Increased cooling capacity during active regeneration is thus ensured.

CLICK HERE TO **DOWNLOAD** THE COMPLETE MANUAL

- Thank you very much for reading the preview of the manual.
- You can download the complete manual from: www.heydownloads.com by clicking the link below



- Please note: If there is no response to CLICKING the link, please download this PDF first and then click on it.

CLICK HERE TO **DOWNLOAD** THE COMPLETE MANUAL

1 Layout

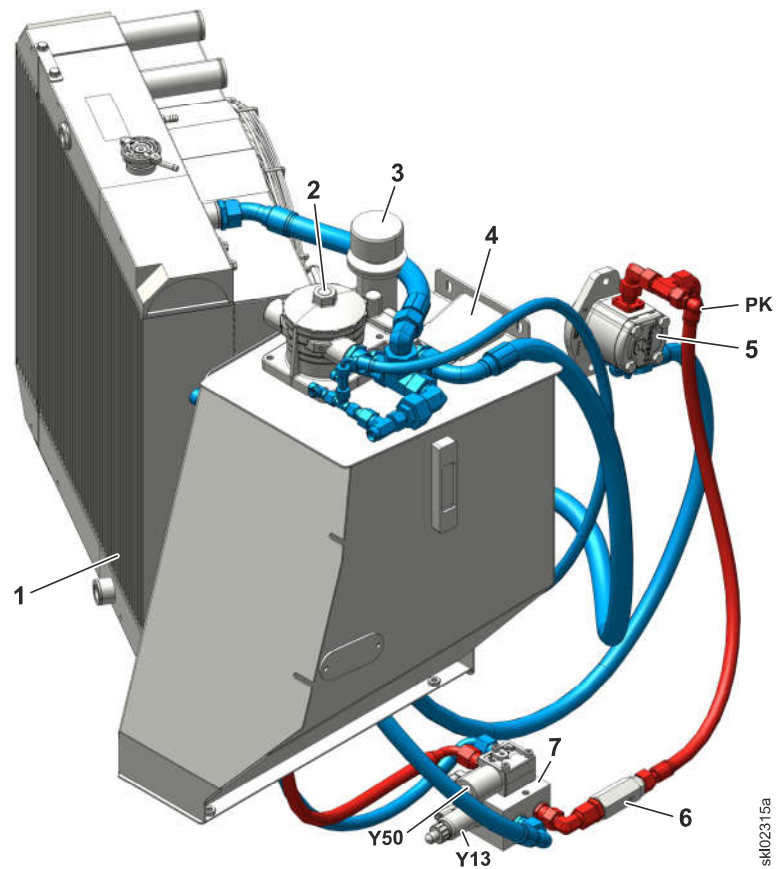

Fig. 356: Reversible fan drive (diesel engine running) (from front left)

- | | | | |
|---|-----------------------|---|--------------------------|
| 1 | Hydraulic oil cooler | 5 | Fan pump |
| 2 | Return suction filter | 6 | In-line filter 80 µm |
| 3 | Breather filter | 7 | Fan reversal valve block |
| 4 | Hydraulic tank | | |

Name	Test point
PK	Cooling system high pressure

Tab. 113: Test points

BMK	Function	BMK	Function
Y13	Fan speed proportional solenoid	Y50	Fan reversal solenoid

Tab. 114: Equipment codes

LBH/12204903/13/211-20211019_135919/en

2 Function

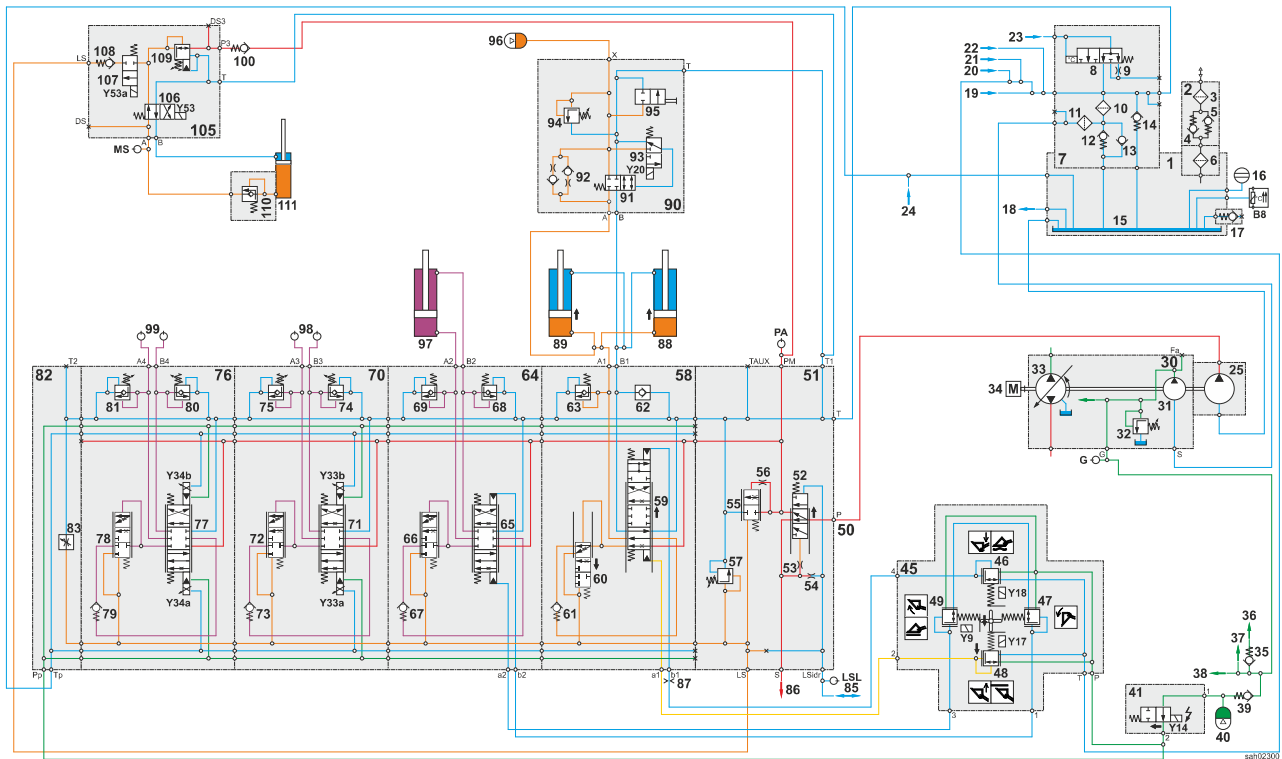

Fig. 363: Hydraulic diagram of working hydraulics with quick coupler (lifting function actuated)

- | | | |
|--|---|---|
| 1 Hydraulic tank | 38 Oils supply for parking brake | 74 Secondary pressure relief valve for 1st additional function B3 |
| 2 Breather filter | 39 Check valve | 75 Secondary pressure relief valve for 1st additional function A3 |
| 3 Fine filter | 40 Pilot control hydro accumulator | 76 Control block section for 2nd additional function (option) |
| 4 Outlet valve 0.35 bar | 41 Pilot pressure solenoid valve | 77 Spool for 2nd additional function |
| 5 Inlet valve 0.03 bar | 45 Pilot control unit | 78 Pressure balance for 2nd additional function |
| 6 Filler strainer 800 µm | 46 Pilot control valve for lowering | 79 Pressure retaining valve for 2nd additional function |
| 7 Return suction filter | 47 Pilot control valve for tilting out | 80 Secondary pressure relief valve for 2nd additional function B4 |
| 8 Temperature valve | 48 Pilot control valve for lifting | 81 Secondary pressure relief valve for 2nd additional function A4 |
| 9 Throttle | 49 Pilot control valve for tilting in | 82 End section |
| 10 Filter element 10 µm | 50 Control block | 83 Flow regulating valve |
| 11 Strainer for replenishing pump | 51 End section | 85 Load sensing signal from servostat |
| 12 Preload valve 0.5 bar | 52 Priority valve | 86 Oil supply to servostat |
| 13 Feeder valve | 53 Throttle 1.0 mm | 87 Orifice 0.6 mm |

See next page for continuation of the image legend

LBH/12204903/13/211-20211019_135919/en

060.4 Control block

Valid for: L518-1655;

1 Layout

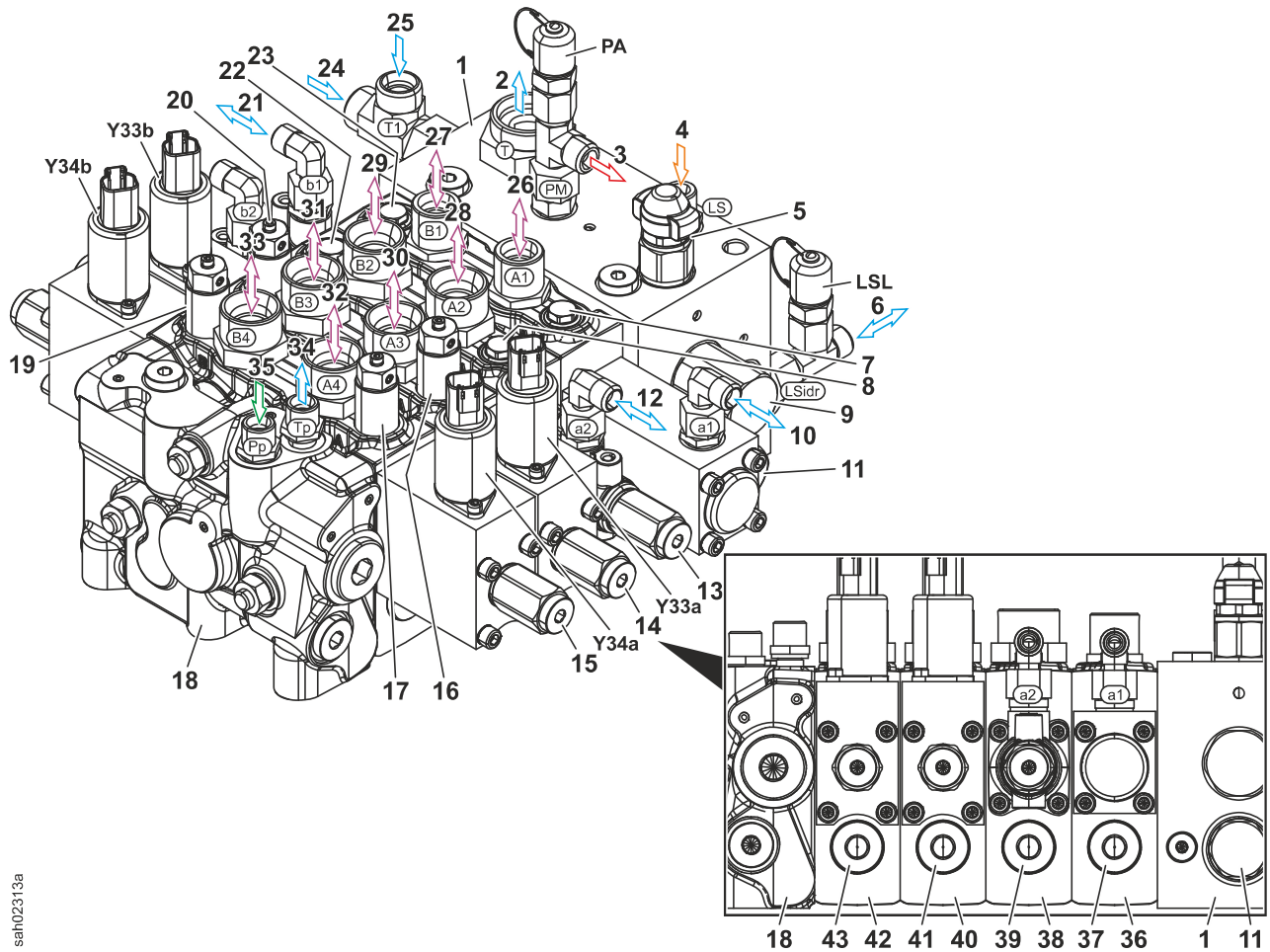

Fig. 369: Control valve block (from front left)

- | | | |
|--|--|---|
| <p>1 End section</p> <p>2 Return flow to return suction filter</p> <p>3 Oil supply for valve block for quick coupler (option)</p> <p>4 Load-sensing signal from valve block for quick coupler (option)</p> <p>5 Working hydraulics LS pressure relief valve</p> | <p>16 Secondary pressure relief valve for 1st additional function A3</p> <p>17 Secondary pressure relief valve for 2nd additional function A4</p> <p>18 End section</p> <p>19 Secondary pressure relief valve for 2nd additional function B4</p> <p>20 Secondary pressure relief valve for 1st additional function B3</p> | <p>31 Connection of 1st additional function B3 (option)</p> <p>32 Connection of 2nd additional function A4 (option)</p> <p>33 Connection of 2nd additional function B4 (option)</p> <p>34 Control oil return flow to hydraulic tank</p> <p>35 Control oil from replenishing pump</p> |
|--|--|---|

See next page for continuation of the image legend

LBH/12204903/13/211-20211019_135919/en

The lift cylinder spool valve **10** has a fourth position for the float position function. If control lever is pushed forward beyond action point, pilot pressure **39** is increased to a level which pushes lift cylinder spool valve **10** to fourth position.

2.6 Pressure circuit balance

Because working pump **35** is a gear pump, it pumps oil as soon as diesel engine is running starts running. Amount of oil delivered therefore depends entirely on engine speed.

If working hydraulics and steering system require less oil than working pump **35** is delivering, pressure circuit balance **7** returns excess oil to hydraulic tank **56**.

When steering system is actuated, priority valve **3** directs required quantity of oil to servostat **37**. Oil that is not required is directed by priority valve **3** to pressure circuit balance **6**.

When working hydraulics are actuated, load sensing signal from pressure balances partially or completely closes pressure circuit balance **6**. Required amount of oil thus flows to working hydraulics.

2.7 Flow regulating valve

Fluid flows continuously through flow regulating valve **34** from load-sensing channel to hydraulic tank **56**. As a result, load sensing signal quickly falls away when a function ceases to be actuated.

2.8 Pressure protection

In the control unit **1** valve block there are two systems that protect the working hydraulics from excess pressure:

- Working hydraulics LS pressure relief valve **8**
- Secondary pressure relief valves **14, 19, 20, 25, 26, 31** and **32**

Working hydraulics LS pressure relief valve **8** restricts load sensing pressure of working hydraulics and therefore pressure with which pressure circuit balance **6** is closed.

The secondary pressure relief valves divert fluid to the hydraulic tank **56** when there are pressure peaks that exceed the maximum working pressure for the consumers. As a result, the pressure quickly decreases. The secondary pressure relief valves thus protect the consumers from excess pressure.

2.9 Feeding function

All secondary pressure relief valves have a replenishing function. Lowering function also has its own replenishing valve **13**.

The feeder valves prevent cavitation during rapid working movements by allowing oil to flow from the tank side to the consumers. Cavitation occurs, for example when quickly lowering the lift arms with a full bucket, because the lift arms are lowered by their own weight.

060.6 Ride control

060.6.1 Overview of ride control system

Valid for: L518-1655;

This equipment is optional.

1 Layout

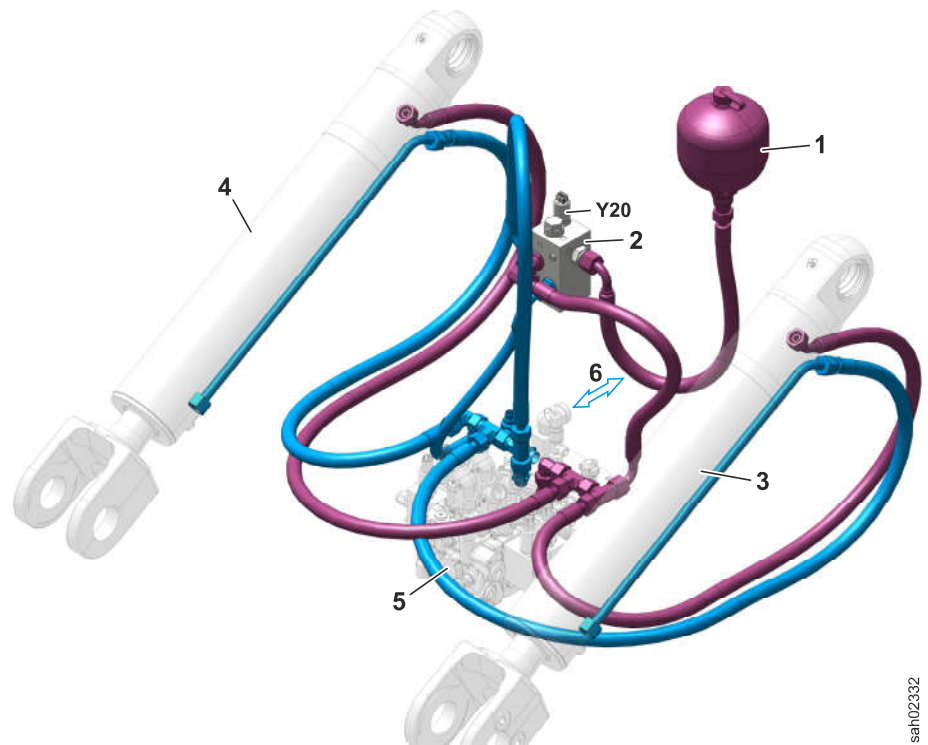

Fig. 384: Ride control system (ride control active) (from front left)

- | | | | |
|---|--------------------------------|---|--------------------------------------|
| 1 | Ride control hydro accumulator | 4 | Right lift cylinder |
| 2 | Stabilization module | 5 | Control block |
| 3 | Left lift cylinder | 6 | Return flow to return suction filter |

BMK	Function
Y20	Solenoid for ride control

Tab. 147: Equipment codes

LBH/12204903/13/211-20211019_135919/en

sah02332

3	Check valve	26	Throttle 0.8 mm	50	Pipe break protection valve block (left lift cylinder)
4	Oil supply for transmission control unit (Speeder only)	27	Working hydraulics LS pressure relief valve	51	Pipe break protection valve
5	Oil for bearing flushing	28	Control valve block section for lift cylinder	52	Check valve
6	Check valve	29	Lift cylinder spool valve	53	Orifice
7	Pilot control hydro accumulator	30	Lift cylinder pressure balance	54	Left lift cylinder
8	Pilot pressure solenoid valve	31	Lift cylinder load retaining valve	55	Pipe break protection valve block (right lift cylinder)
10	Pilot control unit	32	Feeder valve for lowering	56	Pipe break protection valve
11	Pilot control valve for lowering	33	Secondary pressure relief valve for lifting	57	Check valve
12	Pilot control valve for tilting out	34	Control valve block section for tilt cylinder	58	Orifice
13	Pilot control valve for lifting	35	Tilt cylinder spool valve	59	Right lift cylinder
14	Pilot control valve for tilting in	36	Tilt cylinder pressure balance	60	Stabilization module (option)
15	Oil supply for pilot control	37	Tilt cylinder load retaining valve	61	Ride control valve spool
16	Solenoid valve to release ride control (option)	38	Secondary pressure relief valve for tilting out	62	Throttle check valve
17	Return flow to return suction filter	39	Secondary pressure relief valve for tilting in	63	Ride control solenoid valve
18	Oil supply from working pump	40	End section	64	Safety valve
20	Control valve block	41	Flow regulating valve	65	Hydro accumulator relief valve
21	End section	42	Orifice 0.6 mm	66	Ride control hydro accumulator
22	Priority valve	45	Pipe break protection valve block (tilt cylinder)		
23	Throttle 1.0 mm	46	Pipe break protection valve		

Name	Test point	Name	Test point	Name	Test point
LSL	Load sensing signal for steering system	PA	Working hydraulics high pressure	X	Venting connection

Tab. 157: Test points

BMK	Function	BMK	Function	BMK	Function
Y9	Bucket return-to-dig retaining magnet (option)	Y17	Lift kick-out retaining magnet (option)	Y20	Solenoid for ride control
Y14	Solenoid for servo pressure	Y18	Float position retaining magnet	Y21	Solenoid for release of ride control

Tab. 158: Equipment codes

If a pipe breaks, pipe break protection system prevents lift arms from falling and bucket from tipping in an uncontrolled manner. To do this, the pipe break protection system separates the piston side of corresponding hydraulic cylinder from the control valve block.

070.2 Overview of travel hydraulics

Valid for: L518-1655/57749-;

1 Layout

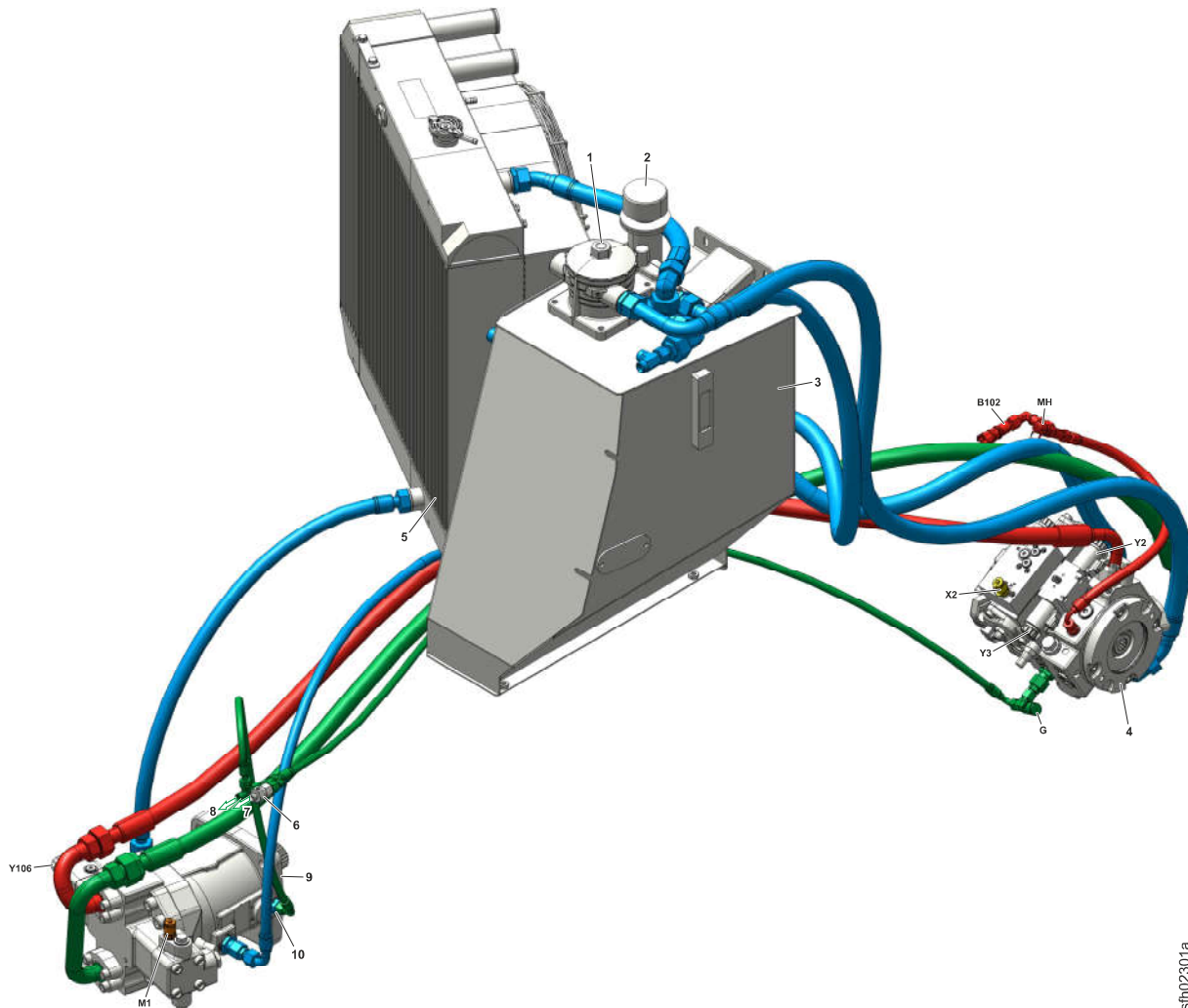

Fig. 401: Travel hydraulics (forward travel direction) (from front left)

- | | | | | | |
|---|-----------------------|---|-------------------------------|----|----------------|
| 1 | Return suction filter | 5 | Hydraulic oil cooler | 9 | Travel motor |
| 2 | Breather filter | 6 | Check valve | 10 | Orifice 1.0 mm |
| 3 | Hydraulic tank | 7 | Oil supply for pilot control | | |
| 4 | Travel pump | 8 | Oils supply for parking brake | | |

Name	Test point	Name	Test point
G	Replenishing pressure	M1	Travel motor servo pressure
MH	Travel pump high pressure	X2	Control pressure for forward travel direction

Tab. 168: Test points

LBH/12204903/13/211-20211019_135919/en

sfh02301a

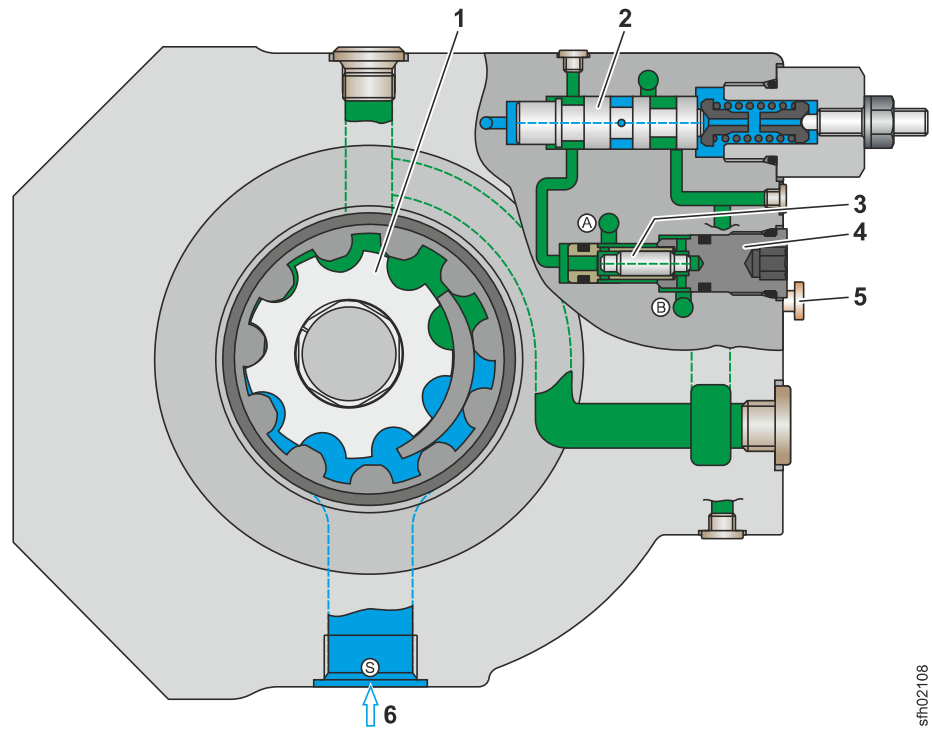

sifh02108

Fig. 409: Replenishing pump, shuttle valve and pressure cut-off: sectional view

- | | |
|---|---|
| <p>1 Replenishing pump
 2 Pressure cut-off valve
 3 Shuttle valve</p> | <p>4 Towing bypass
 5 Stop bolt for towing bypass
 6 Suction port of replenishing pump of return suction filter</p> |
|---|---|

LBH/12204903/13/211-20211019_135919/en

070.4 Travel motors

070.4.1 Travel motor

Valid for: L518-1655;

1 Layout

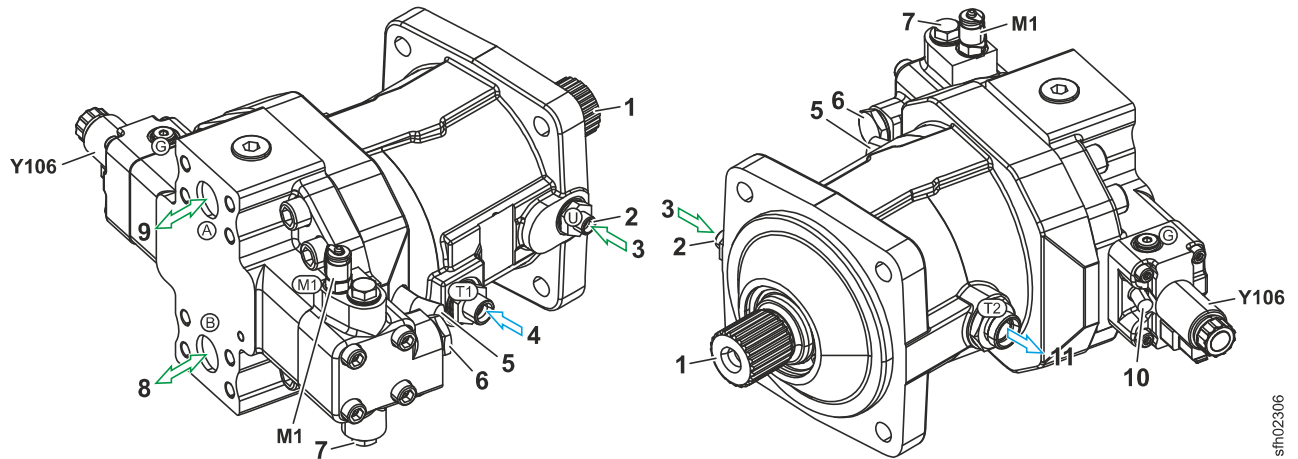

Fig. 419: Travel motor (from front left and from rear right)

- | | | | | | |
|---|---|---|--|----|--|
| 1 | Output shaft | 5 | Adjusting screw for Q_{min} | 9 | Oil supply from travel pump (forward travel direction high pressure) |
| 2 | Orifice 1.0 mm | 6 | Pressure relief valve | 10 | Adjusting screw for regulation |
| 3 | Oil from the replenishing pump (bearing flushing) | 7 | Discharge valve | 11 | Leak oil to hydraulic oil cooler |
| 4 | Return flow from fan motor (housing flushing / cooling) | 8 | Oil supply from travel pump (reverse travel direction high pressure) | | |

Name	Test point
M1	Travel motor servo pressure

Tab. 184: Test points

BMK	Function
Y106	Servo pressure proportional solenoid (travel motor)

Tab. 185: Equipment codes

The travel motor is attached to the gearbox.

The travel motor is an axial piston variable displacement motor for the closed circuit.

LBH/12204903/13/211-20211019_135919/en

sfh02306

2 Function

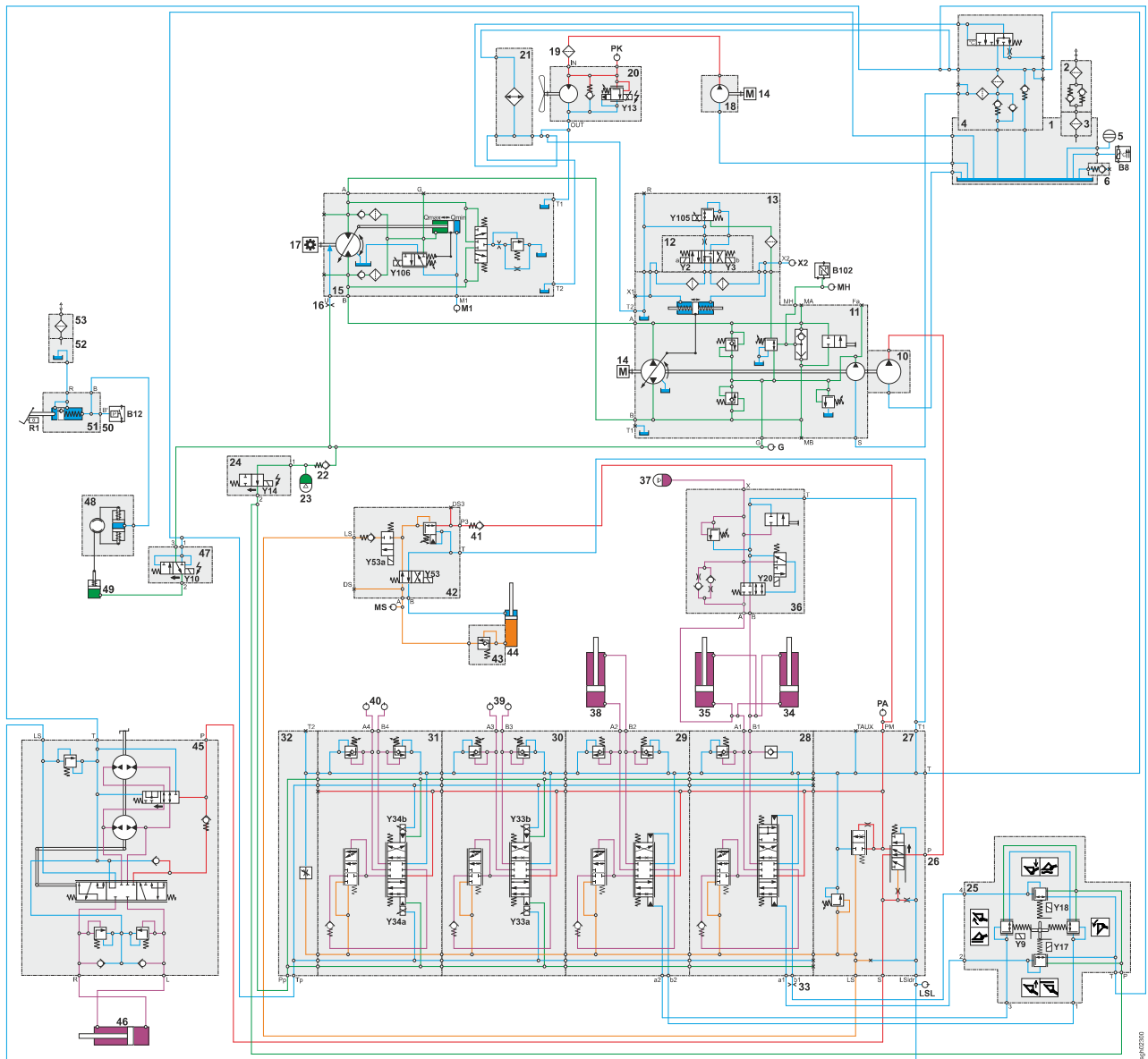

Fig. 425: Diagram of hydraulic system (diesel engine is running)

- | | | |
|--|---|--|
| 1 Hydraulic tank | 21 Hydraulic oil cooler | 38 Tilt cylinder |
| 2 Breather filter | 22 Check valve | 39 Quick coupler for 1st additional function (option) |
| 3 Filler strainer 800 µm | 23 Pilot control hydro accumulator | 40 Quick coupler for 2nd additional function (option) |
| 4 Return suction filter | 24 Pilot pressure solenoid valve | 41 Check valve (from serial no. 51095) |
| 5 Sight glass for hydraulic oil level | 25 Pilot control unit | 42 Valve block for quick coupler (option) |
| 6 Hydraulic oil drain valve | 26 Control block | 43 Preload valve 15 bar |
| 10 Working pump | 27 End section | 44 Quick coupler locking hydraulic cylinder |

See next page for continuation of the image legend

LBH12204903/13/211-20211019_135919/en

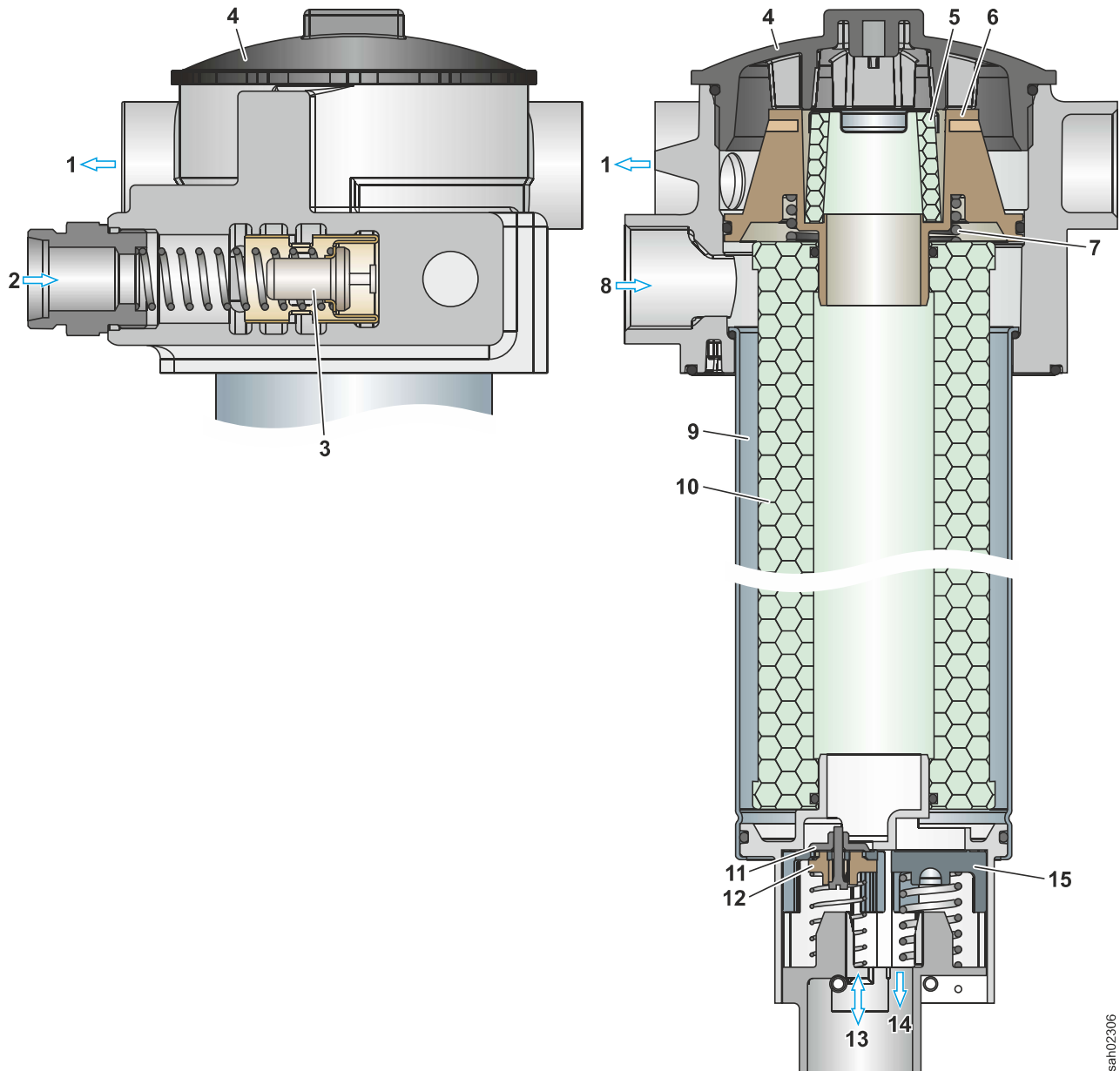

Fig. 432: Return-suction filter: sectional view

- | | | |
|---|---|------------------------------------|
| 1 Replenishing pump suction port | 6 Filter separator plate | 11 Replenishing valve |
| 2 Return flow to the return suction filter (via temperature valve) | 7 Compression spring | 12 Preload valve 0.5 bar |
| 3 Temperature valve | 8 Return flow to return suction filter | 13 Connection to steel tank |
| 4 Filter cover | 9 Filter casing | 14 Connection to steel tank |
| 5 Strainer for replenishing pump | 10 Filter element 10 µm | 15 Bypass valve 2.5 bar |

sah02306

LBH/12204903/13/211-20211019_135819/en

2.4 Bypass valve

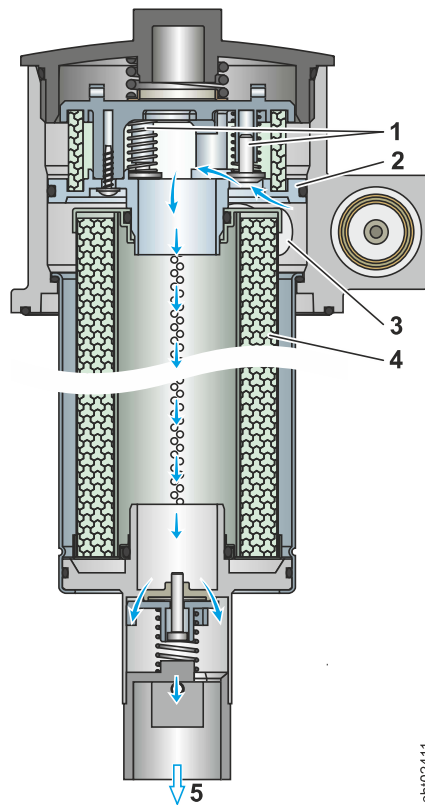

sht02411

Fig. 443: Bypass valve

- | | | | |
|---|------------------------|---|---------------------------------|
| 1 | Bypass valve (3x) | 4 | Filter element 10 μm |
| 2 | Filter separator plate | 5 | Connection to steel tank |
| 3 | Return oil | | |

In filter separator plate 2, three bypass valves 1 are installed. They protect system from high pressure.

If not enough hydraulic oil passes through filter element because oil is cold or filter element 4 is clogged, some of oil flows unfiltered via bypass valves 1 directly into steel tank 5. This prevents the hydraulic components being damaged.

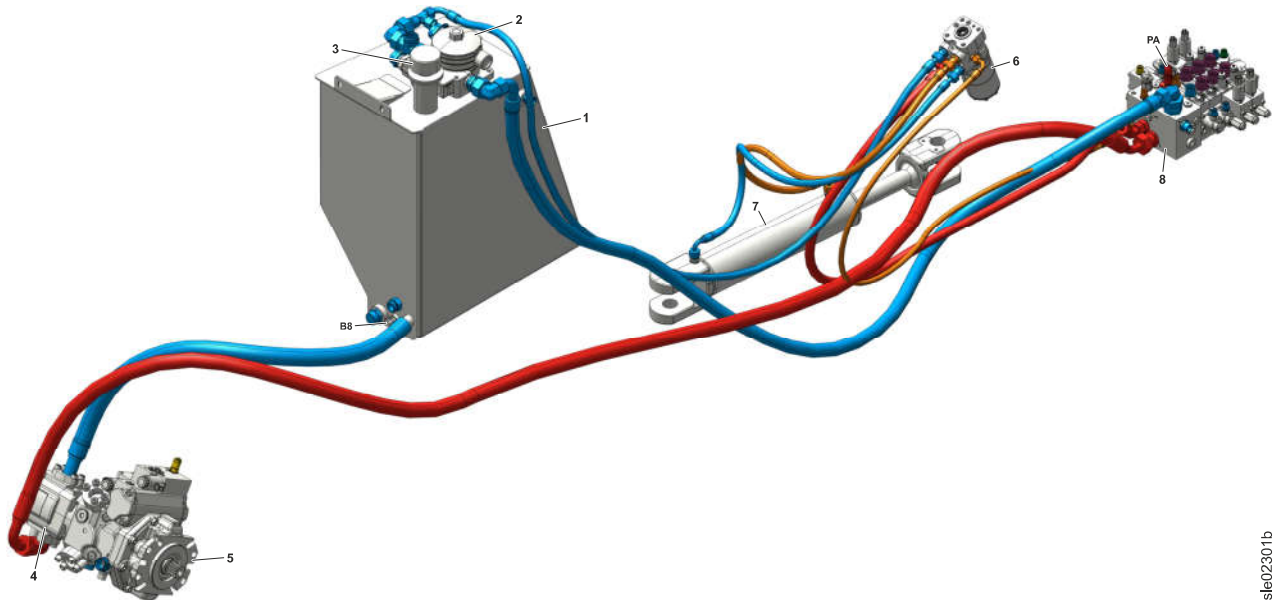

Fig. 453: Steering system (steering to left) (from rear right)

- | | | | | | |
|---|-----------------------|---|--------------|---|-------------------|
| 1 | Hydraulic tank | 4 | Working pump | 7 | Steering cylinder |
| 2 | Return suction filter | 5 | Travel pump | 8 | Control block |
| 3 | Breather filter | 6 | Servostat | | |

Name	Test point
PA	Working hydraulics high pressure

Tab. 207: Test points

BMK	Function
B8	Hydraulic oil temperature sensor

Tab. 208: Equipment codes

The steering system consists of the following components:

- Hydraulic tank (For more information see: 080.3.1 Overview of hydraulic tank, page 080-8)
- Working pump (For more information see: 060.3 Working pump, page 060-14)
- Control block (For more information see: 060.4 Control block, page 060-15)
- Servostat (For more information see: 090.3 Servostat, page 090-10)
- Steering cylinder

LBH/12204903/13/211-20211019_135919/en

sle02301b

BMK	Function	BMK	Function	BMK	Function
B12	Brake light pressure switch	R1	Inching function angle sensor	Y10	Parking brake solenoid

Tab. 212: Equipment codes

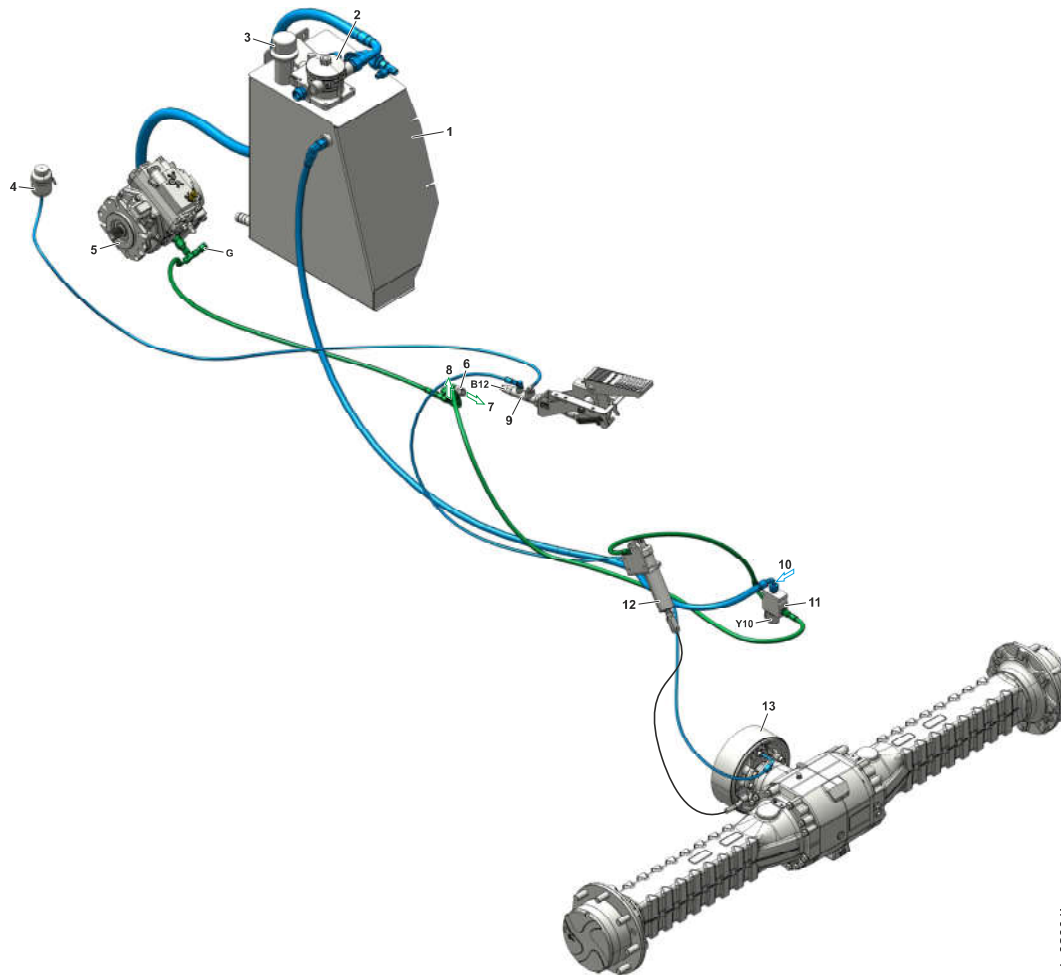

Fig. 459: Brake system (parking brake deactivated) (from front right)

- | | | | | | |
|---|-----------------------|----|---|----|---|
| 1 | Hydraulic tank | 6 | Check valve | 11 | Parking brake solenoid valve |
| 2 | Return suction filter | 7 | Oil supply for pilot control | 12 | Spring accumulator cylinder for parking brake |
| 3 | Breather filter | 8 | Oil for bearing flushing | 13 | Drum brake |
| 4 | Equalising reservoir | 9 | Inch/brake unit | | |
| 5 | Travel pump | 10 | Return flow from pilot control of additional functions (option) | | |

Name	Test point
G	Replenishing pressure

Tab. 213: Test points

LBH/12204903/13/211-20211019_135919/en

sbr02301b

For the service brake, the brake piston **5** generates the braking force.

When braking, the main brake cylinder pushes oil into the brake piston **5**. The brake piston **5** extends and pushes the brake shoes **6** and **4** against the rotating brake drum **8**.

To ensure that both brake linings lie fully on the brake drum **8**, the brake linings move against the adjuster **1**: if the brake drum **8** is turning clockwise **CW**, the right brake shoe **6** moves with the brake drum **8** and is pushed against the adjuster **1**. The adjuster **1** moves left out of the way and pushes the left brake shoes **4** against the bracket of the brake piston **5**. Both brake shoes lie fully on the brake drum **8**.

If the brake drum **8** is turning anticlockwise **CCW**, the left brake jaw **4** moves with the brake drum **8**.

2.1.2 Parking brake

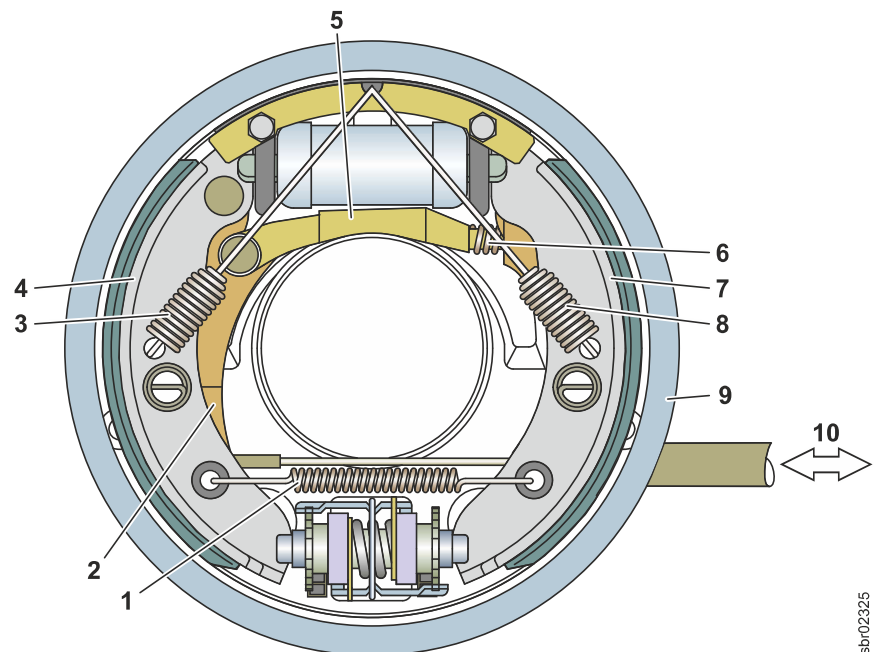

Fig. 469: Parking brake

- | | | | |
|----------|-----------------------|-----------|----------------------------|
| 1 | Return spring | 6 | Spacer return spring |
| 2 | Parking brake linkage | 7 | Right brake shoe |
| 3 | Return spring | 8 | Return spring |
| 4 | Left brake shoe | 9 | Brake drum |
| 5 | Parking brake spacer | 10 | Parking brake bowden cable |

For the parking brake, the braking force is generated by the spring accumulator cylinder, which pulls the bowden cable **10** with spring force.

By pulling the bowden cable **10**, the parking brake linkage **2** pushes the left brake shoe **4** against the brake drum **9**. At the same time, the parking brake spacer **5** pushes the right brake shoe **7** against the brake drum **9**.

110 Electrical system

Contents

110.1	Overview of electrical system <i>L518-1655;</i>	110-3
110.2	Lighting <i>L518-1655;</i>	110-7
110.3	Circuit diagrams <i>L518-1655;</i>	110-9
110.4	Electronic control unit	110-11
110.4.1	General overview of the electronic control system <i>L518-1655/0-60066;</i>	110-11
110.4.2	General overview of electronic control system <i>L518-1655/60067-;</i>	110-13
110.4.3	Central control unit (Master4) <i>L518-1655/0-60066;</i>	110-14
110.4.4	Central control unit (Master5 Mini) <i>L518-1655/60067-;</i>	110-19
110.4.5	Modules	110-21
110.4.5.1	Overview of compact module <i>L518-1655;</i>	110-21
110.4.5.2	Compact module <i>L518-1655;</i>	110-23
110.5	Electrical components of the driver's cab	110-29
110.5.1	Overview of electrical components in the operator's cab <i>L518-1655;</i>	110-29
110.5.2	Fuse boards <i>L518-1655;</i>	110-31
110.5.3	Door contact switch <i>L518-1655;</i>	110-33
110.6	Electrical components in the rear section	110-34
110.6.1	Battery installation <i>L518-1655;</i>	110-34
110.7	Rear area monitoring with camera	110-36
110.7.1	Overview of rear area monitoring with camera <i>L518-1655;</i>	110-36

PROJECT
SERIE_L514-L518
1583 00090 01 00
DRAWING NUMBER
1583 00090 01 00
ITEM CODE
13434870
DRAWING INDEX
101

L514-1583
L514-1663 (Speeder)
L518-1655
L518-1664 (Speeder)

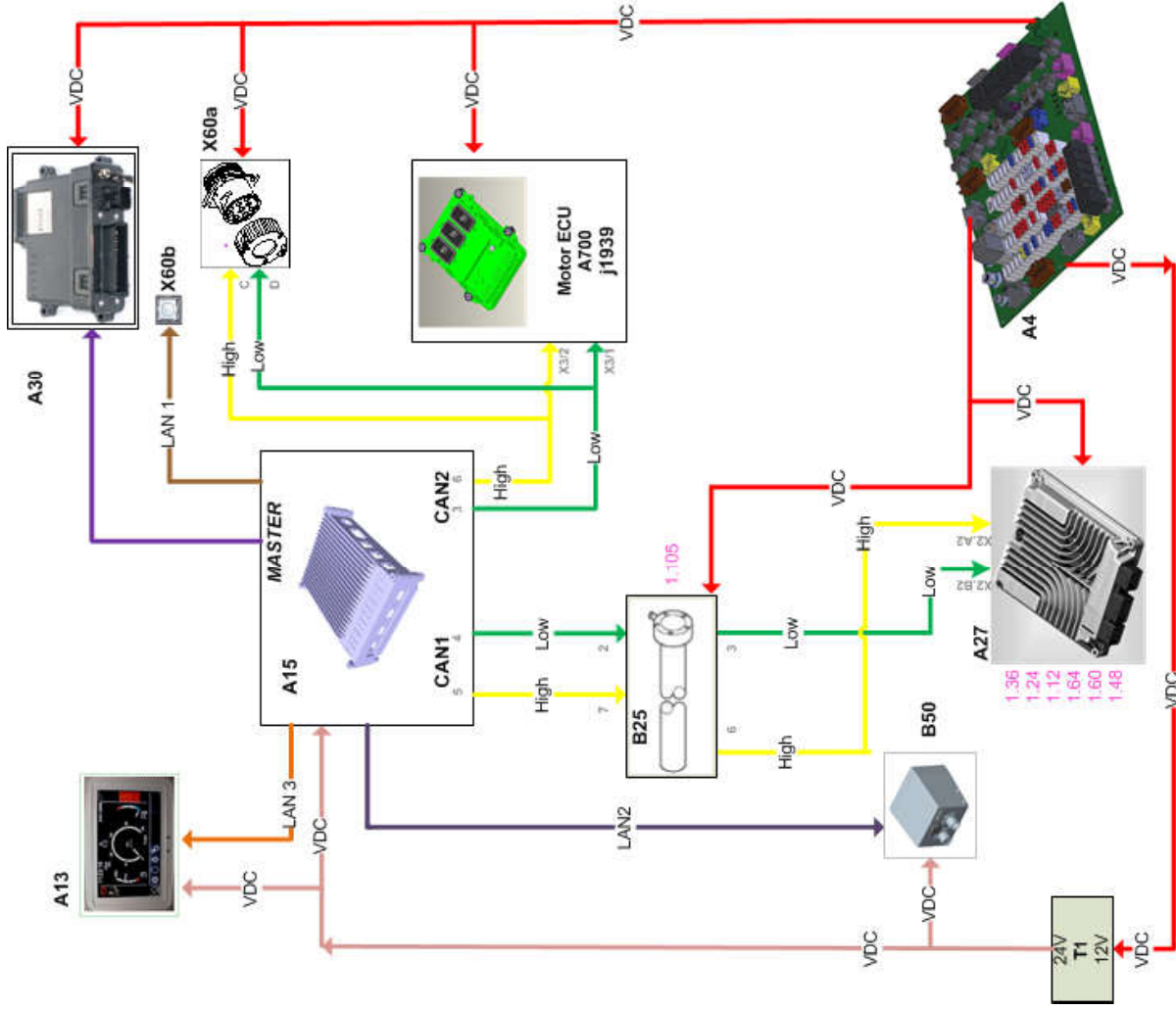

MACHINE TYPE

SERIAL NUMBER

LIEBHERR
FACTORY LBH

BLOCK DIAGRAM
E PLAN

PAGE 1 OF

CREATION DATE

24.11.2021 08:48

PROJECT: SERIE L514-L518 1583 00090 01 00
 DRAWING NUMBER: 13434870
 ITEM CODE: 101
 DRAWING INDEX

BMK	SYSTEM	LOCATION	FUNCTION	PAGE
-S4.X	=K	+K	PLUG SWITCH HAZARD WARNING LIGHT	/43.A2
-S6	=K	+K	SWITCH DRIVING LIGHT	/42.B1
-S6.X	=K	+K	PLUG SWITCH DRIVING LIGHT	/42.A2
-S7	=K	+K	SWITCH WORKING PROJECTOR FRONT	/28.A6
-S7.X	=K	+K	PLUG SWITCH WORKING PROJECTOR FRONT	/28.B6
-S8	=K	+K4	SWITCH WORKING PROJECTOR REAR	/29.B7
-S8.X	=K	+K4	PLUG SWITCH WORKING PROJECTOR REAR	/29.B7
-S8a	=K	+K4	SWITCH WORKING PROJECTOR OPTIONAL	/29.B4
-S8a.X	=K	+K4	PLUG SWITCH WORKING PROJECTOR OPTIONAL	/29.B5
-S9	=K	+K4	SWITCH BEACONLIGHT	/31.C3
-S9.X	=K	+K4	PLUG SWITCH BEACONLIGHT	/31.D3
-S9a	=K	+K4	SWITCH BEACONLIGHT OPTIONAL	/31.C5
-S9a.X	=K	+K4	PLUG SWITCH BEACONLIGHT OPTIONAL	/31.C5
-S13	=K	+K	SWITCH WINDSCREEN WIPER REAR	/40.B3
-S13.X	=K	+K	PLUG SWITCH WINDSCREEN WIPER REAR	/40.C3
-S14	=K	+K4	SWITCH BUCKET RETURN-TO-DIG	/23.C6
-S14.X	=K	+K4	PLUG SWITCH BUCKET RETURN-TO-DIG	/23.C6
-S15	=H	+H4	BATTERY MAIN SWITCH	/17.E7
-S16	=K	+K4	PUSH-BUTTON SWITCH RIDE CONTROL	/24.C6
-S16.X	=K	+K4	PLUG PUSH-BUTTON SWITCH RIDE CONTROL	/24.D6
-S17	=K	+K	PUSH-BUTTON SWITCH PARKING BRAKE	/25.D2
-S17.X	=K	+K	PLUG PUSH-BUTTON SWITCH PARKING BRAKE	/25.D2
-S18	=K	+K4	SWITCH FLOAT POSITION	/23.C2
-S18.X	=K	+K4	PLUG SWITCH FLOAT POSITION	/23.C2
-S19	=K	+K4	PUSH-BUTTON SWITCH WORKING HYDRAULICS LOCKOUT	/22.C2
-S19.X	=K	+K4	PLUG PUSH-BUTTON SWITCH WORKING HYDRAULICS LOCKOUT	/22.C2
-S23	=K	+K4	PUSH-BUTTON SWITCH QUICK-CHANGE DEVICE	/63.D2
-S23.X	=K	+K4	PLUG PUSH-BUTTON SWITCH QUICK-CHANGE DEVICE	/63.D2
-S43	=K	+K4	SWITCH BACK-UP ALARM	/64.C3
-S43.X	=K	+K4	PLUG SWITCH BACK-UP ALARM	/64.C3
-S46	=K	+K4	PUSH-BUTTON SWITCH REAR WINDOW HEATER	/44.B6
-S46.X	=K	+K4	PLUG PUSH-BUTTON SWITCH REAR WINDOW HEATER	/44.C6
-S47	=K	+K4	PUSH-BUTTON SWITCH CONTROL LEVEL MOUNTING	/20.C7
-S47.X	=K	+K4	PLUG SWITCH CONTROL LEVEL MOUNTING	/20.D7
-S55	=V	+V	PUSH-BUTTON SWITCH 100% DIFFERENTIAL LOCK	/19.E5
-S55.X1	=V	+V	PLUG PUSH-BUTTON SWITCH 100% DIFFERENTIAL LOCK	/19.D5

BMK	SYSTEM	LOCATION	FUNCTION	PAGE
-S55.X2	=V	+V	PLUG PUSH-BUTTON SWITCH 100% DIFFERENTIAL LOCK	/19.E5
-S57	=K	+K4	SWITCH LIFT KICK-OUT	/65.C6
-S57.X	=K	+K4	PLUG SWITCH LIFT KICK-OUT	/65.D6
-S70	=K	+K5	DOOR CONTACT SWITCH	/41.D8
-S70.X1	=K	+K5	PLUG DOOR CONTACT SWITCH	/41.E8
-S70.X2	=K	+K5	PLUG DOOR CONTACT SWITCH	/41.D8
-S100	=K	+K4	PUSH-BUTTON SWITCH TRAVEL RANGE	/24.C3
-S100.X	=K	+K4	PLUG PUSH-BUTTON SWITCH TRAVEL RANGE	/24.C3
-S101	=K	+K4	PUSH-BUTTON SWITCH MODE	/24.C4
-S101.X	=K	+K4	PLUG PUSH-BUTTON SWITCH MODE	/24.C4
-S178	=H	+H2	SWITCH REFUELLING PUMP	/72.E2
-S203	=K	+K4	PUSH-BUTTON SWITCH VENTILATOR REVERSIBLE	/21.C4
-S203.X	=K	+K4	PLUG PUSH-BUTTON SWITCH VENTILATOR REVERSIBLE	/21.D4
-S300	=K	+K4	SWITCH FLASHING WARNING LIGHT	/67.C6
-S300.X	=K	+K4	PLUG SWITCH FLASHING WARNING LIGHT	/67.C6
-S301	=K	+K4	PUSH-BUTTON SWITCH V-MAX	/66.C4
-S301.X	=K	+K4	PLUG PUSH-BUTTON SWITCH V-MAX	/66.C4
-S302	=K	+K4	PUSH-BUTTON SWITCH TRACTIVE FORCE DEMAND	/78.D2
-S302.X	=K	+K4	PLUG PUSH-BUTTON SWITCH TRACTIVE FORCE DEMAND	/78.D2
-S303	=K	+K4	KEY SPEED	/66.C7
-S305	=K	+K4	SWITCH PRESSURE RELIEF	/66.C3
-S305.X	=K	+K4	PLUG SWITCH PRESSURE RELIEF	/66.D3
-S323	=K	+K4	SWITCH SWEEPING MACHINE	/70.D6
-S323.X	=K	+K4	PLUG SWITCH SWEEPING MACHINE	/70.D6
-S324	=K	+K4	PUSH-BUTTON SWITCH CENTRAL LUBRICATION SYSTEM	/71.C3
-S324.X	=K	+K4	PLUG PUSH-BUTTON SWITCH CENTRAL LUBRICATION SYSTEM	/71.D3
-S700	=K	+K4	SWITCH DIESEL PARTICULATE FILTER	/49.D2
-S700.X	=K	+K4	PLUG SWITCH DIESEL PARTICULATE FILTER	/49.D2
-S701	=K	+K4	SWITCH LIFT KICK-OUT	/51.B8
-S702	=K	+K4	SWITCH LIFT KICK-OUT	/52.B8
-T1	=K	+K3	VOLTAGE CONVERTER 12 UP 24 VOLTS	/32.B2
-T1.X	=K	+K3	PLUG VOLTAGE CONVERTER 12 UP 24 VOLTS	/32.B3
-T1.X1.B	=K	+K	ADAPTOR VOLTAGE CONVERTER	/57.D2
-T1.X1.B1	=K	+K	VOLTAGE CONVERTER	/57.C2
-T1.X1.B2	=K	+K	VOLTAGE CONVERTER	/57.C1
-T1.X1.B3	=K	+K	VOLTAGE CONVERTER	/57.C2



ISO 15715: The reproduction, distribution and utilization of this document as well as the communication of its contents to others without express authorization is prohibited. Violations require compensation. All rights reserved in the case of patent, utility, model or design registration.

13434870
ITEM CODE

101
DRAWING INDEX

SERIE_L514-L518
1583 0090 01 00

PROJECT
DRAWING NUMBER

ISO 15076: The reproduction, distribution and utilization of this document as well as the communication of its contents to others without express authorization is prohibited. Violations require compensation. All rights reserved in the case of patent, utility, model or design registration.

VENTILATOR

OPTION REVERSIBLE VENTILATOR

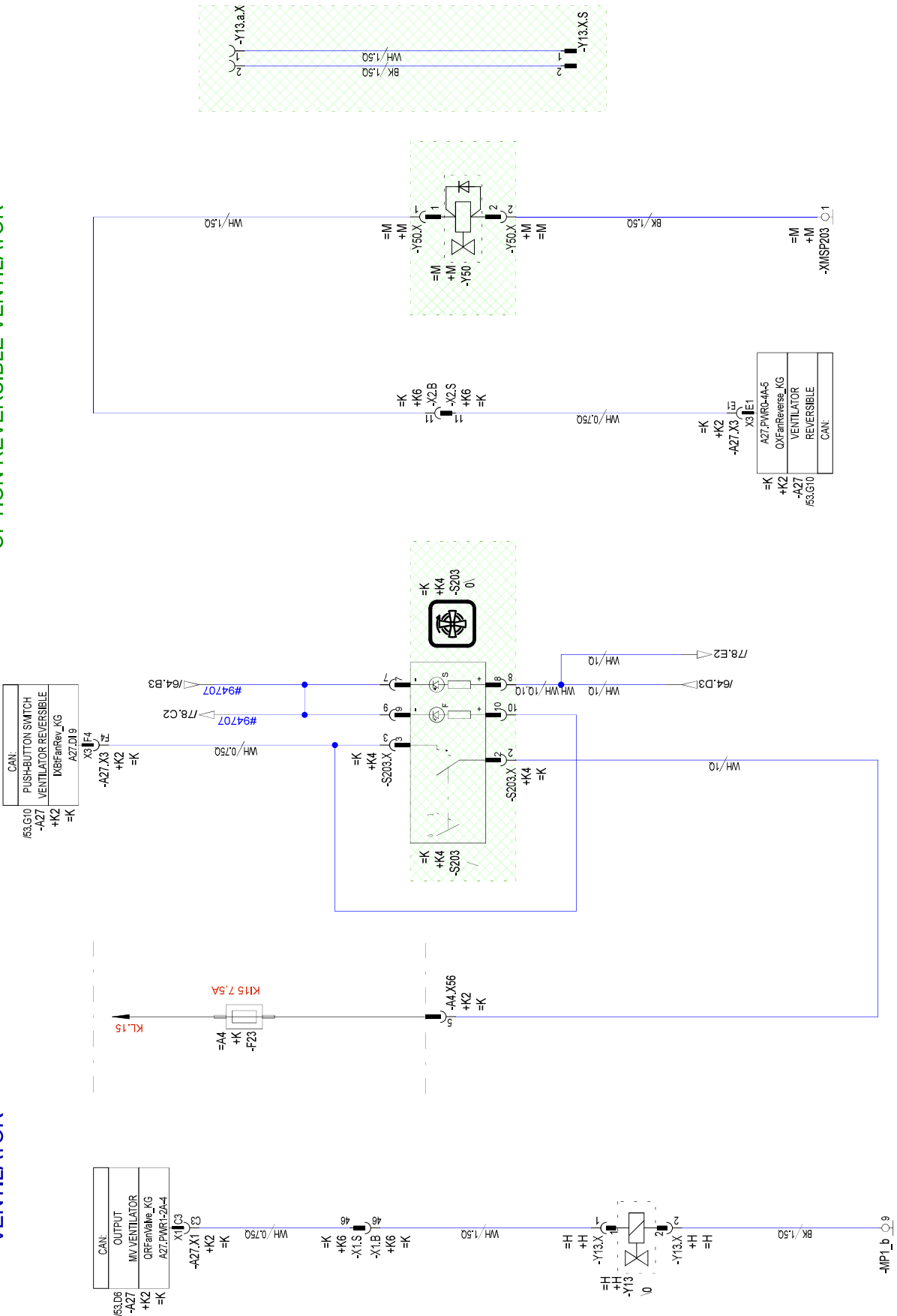

CAN:	OUTPUT
F53.D8	IM VENTILATOR
-A27	ORFanValve_JG
+K2	A27.PWR1-2A-4
=K	

CAN:	PUSH-BUTTON SWITCH
F53.G10	VENTILATOR REVERSIBLE
-A27	IMFanRev_JG
+K2	A27.D19
=K	

=K	A27.PWR1-4A-5
+K2	0XFanReverse_JG
-A27	VENTILATOR
F53.G10	REVERSIBLE
=K	CAN:

MACHINE TYPE

SERIAL NUMBER

LIEBHERR
FACTORY LBH

VENTILATOR - OPTION VENTILATOR REVERSIBLE
E PLAN

PAGE 21 OF

CREATION DATE 24.11.2021 08:48

BEACONLIGHT

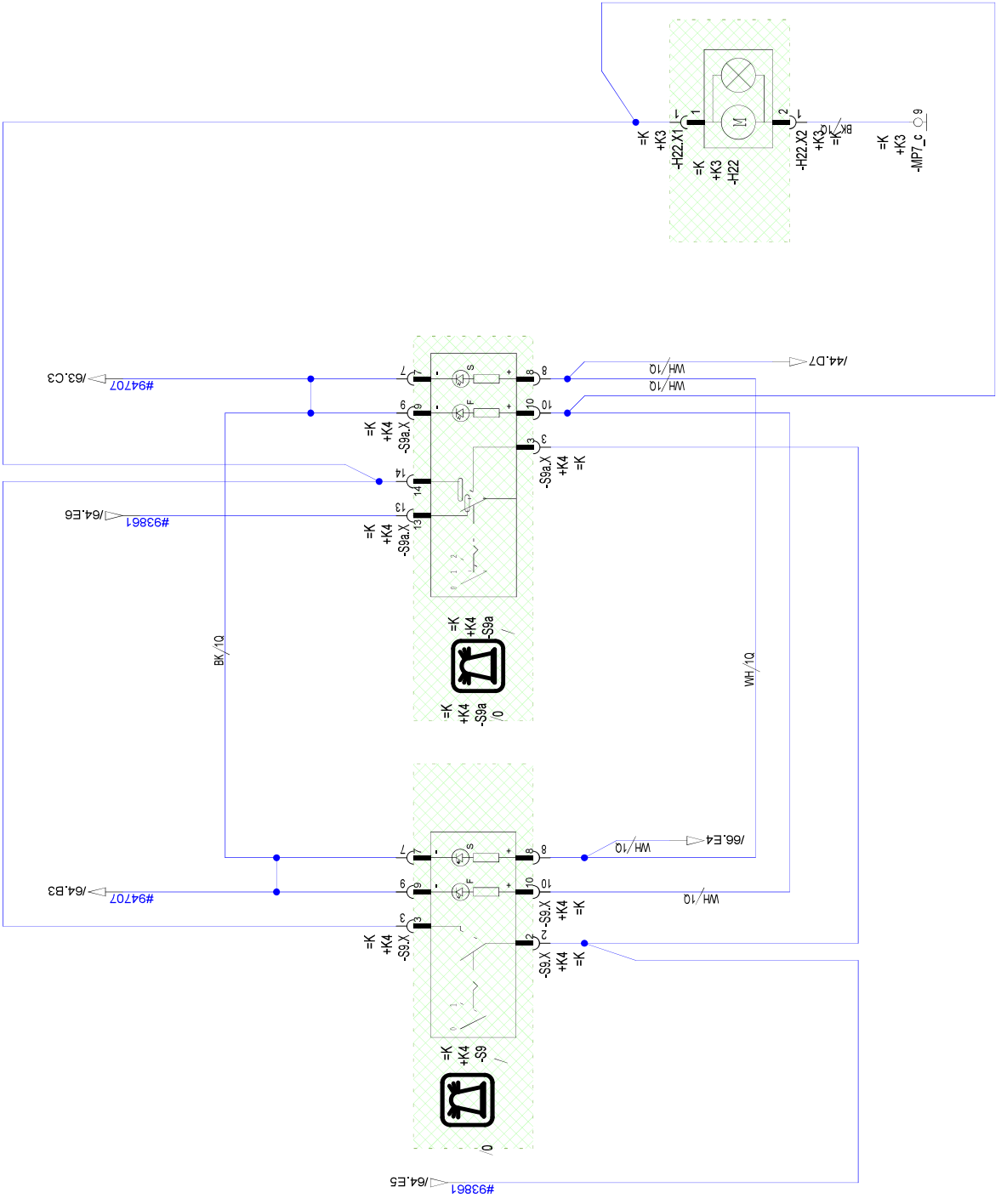

13434870
ITEM CODE

101
DRAWING INDEX

SERIE_L514-L518
1583 00090 01 00
DRAWING NUMBER

PROJECT

Violations require compensation. All rights reserved in the case of patent, utility, model or design registration. The reproduction, distribution and utilization of this document as well as the communication of its contents to others without express authorization is prohibited.

MACHINE TYPE

SERIAL NUMBER

LIEBHERR
FACTORY LBH

OPTION BEACONLIGHT
E PLAN

PAGE 31 OF

CREATION DATE 24.11.2021 08:48

1 2 3 4 5 6 7 8

A

B

C

D

E

F

1 2 3 4 5 6 7 8

PROJECT SERIE_L514-L518 1583 0090 01 00 DRAWING NUMBER 13434870 101 ITEM CODE DRAWING INDEX

Violations require compensation. All rights reserved in this document and utilization of its contents to others without express authorization is prohibited.

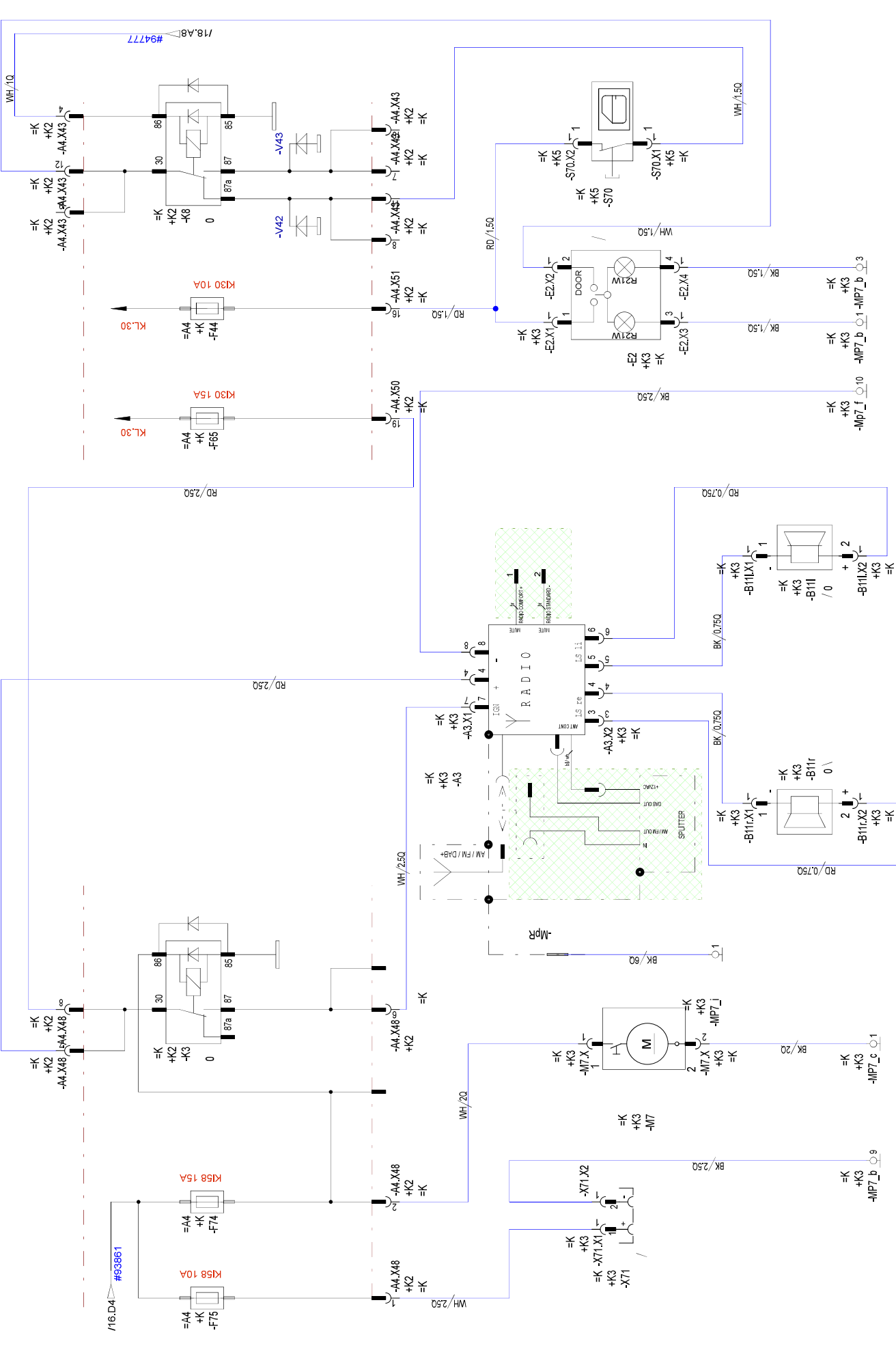

SWITCH AND PUSH-BUTTON SWITCH BOTTOM

PARKING BRAKE	CENTRAL LIBERATION SYSTEM	DFP	SWEEEPING MACHINE	MODE	LFD	QUICK-CHANGE DEVICE	BUCKET RETURN TO CHARG	FLOAT POSITION	LIFT MICK-OUT
SERIES	OPTION	SERIES	OPTION	SERIES	OPTION	OPTION	SERIES	SERIES	OPTION
				MODE					
35510	35533	35546	S323	35521	35525	35527	35517	35516	35537
S17	S324	S700	S323	S 101	S16	S23	S14	S18	S57
LBH N°. 11821732	LBH N°. 11821772	LBH N°. 11821781		LBH N°. 11821747	LBH N°. 11821733	LBH N°. 12201354	LBH N°. 11821736	LBH N°. 11821750	LBH N°. 11821861
Pos.12	Pos.11	Pos.10	Pos.9	Pos.8	Pos.7	Pos.6	Pos.3	Pos.2	Pos.1

TRACTIVE FORCE DEMAND	SWITCH V-MAX	CONTROL LEVEL MOUNTING	FAN REVERSAL	RUCKFAHRW. ACOUSTIC	100% LOCKOUT
SERIES	OPTION	OPTION	OPTION	OPTION	OPTION/NEU
S302	S301	35529	35538	35539	35616
		S47	S203	S43	H42
LBH N°. 12212119	LBH N°. 11841003	LBH N°. 12220164	LBH N°. 11821779	LBH N°. 11839397	LBH N°. 11825227
Pos.9	Pos.8	Pos.7	Pos.6	Pos.5	Pos.4



3X 6 fach FRAME 11698894
1X 3 fach FRAME 11698887

TRAVELLING DIRECTION

MACHINE TYPE

SERIAL NUMBER

LIEBHERR
FACTORY LBH

SWITCH AND PUSH-BUTTON SWITCH BOTTOM
E PLAN

PAGE 51 OF

CREATION DATE

24.11.2021 08:48

13434870
ITEM CODE

DRAWING INDEX 101

SERIE_L514-L518
1583 00090 01 00

PROJECT
DRAWING NUMBER

ISO 15076: The reproduction, distribution and utilization of this document as well as the communication of its contents to others without express authorization is prohibited. Violations require compensation. All rights reserved in the case of patent, utility, model or design registration.

13434870

ITEM CODE

101

DRAWING INDEX

SERIE_L514-L518

1583 00090 01 00

PROJECT

DRAWING NUMBER

150716: The reproduction, distribution and utilization of this document as well as the communication of its contents to others without express authorization is prohibited. Violations require compensation. All rights reserved in the case of patent, utility model or design registration.

MACHINE TYPE

SERIAL NUMBER

LIEBHERR
FACTORY LBH

OPTION CENTRAL LUBRICATION SYSTEM
E PLAN

PAGE 71 OF

CREATION DATE 24.11.2021 08:48

OPTION CENTRAL LUBRICATION SYSTEM

TRANSFER

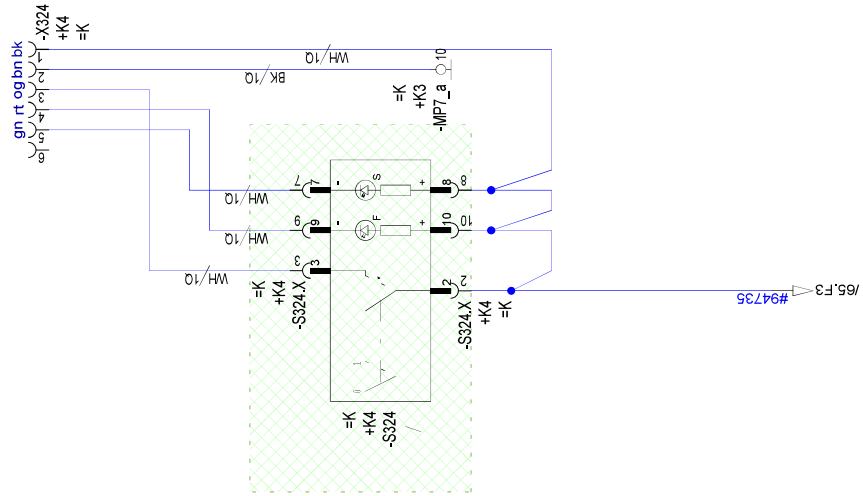

1 2 3 4 5 6 7 8

A

B

C

D

E

F

OPTION ELECTRICAL SOCKET AT REAR

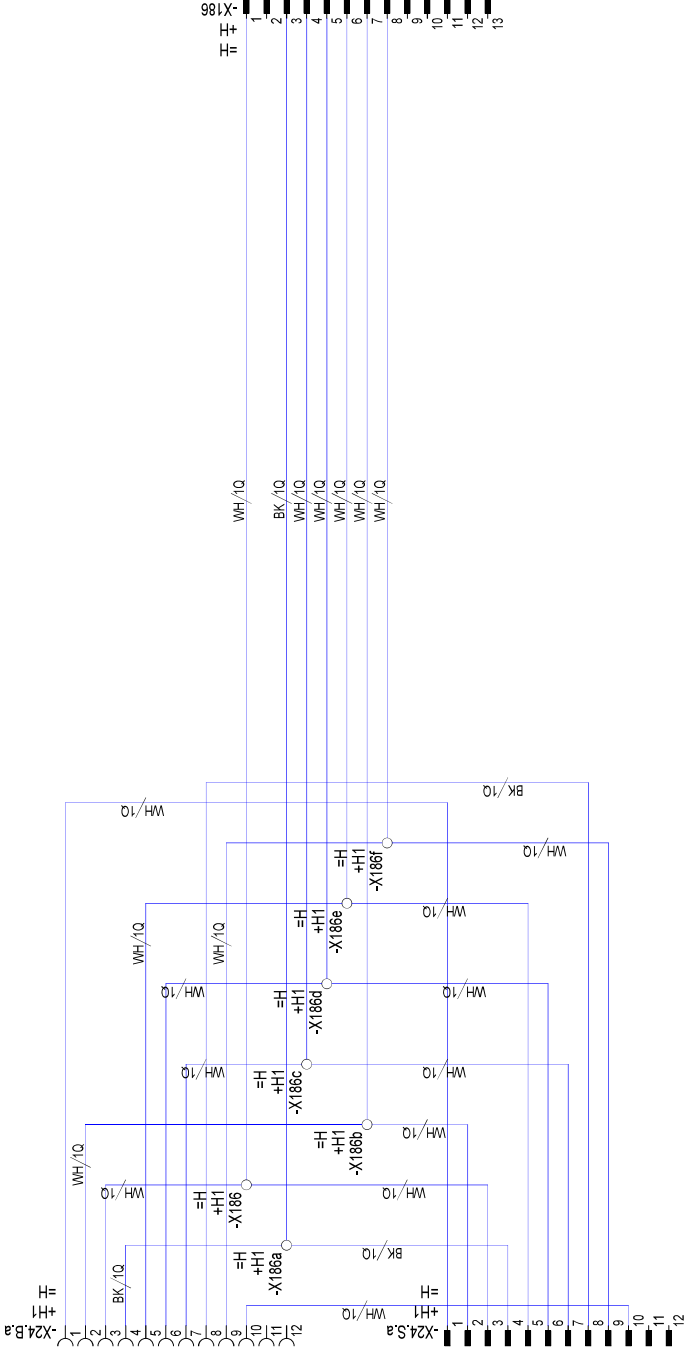

13434870
ITEM CODE

101
DRAWING INDEX

SERIE_L514-L518
1583 00090 01 00

PROJECT
DRAWING NUMBER

ISO 15076: The reproduction, distribution and utilization of this document as well as the communication of its contents to others without express authorization is prohibited. Violations require compensation. All rights reserved in the case of patent, utility, model or design registration.

MACHINE TYPE

SERIAL NUMBER

LIEBHERR
FACTORY LBH

OPTION ELECTRICAL SOCKET AT REAR
E PLAN

PAGE 81 OF

CREATION DATE 24.11.2021 08:48

13434870
ITEM CODE

101
DRAWING INDEX

SERIE_L514-L518
1583 0090 01 00

DRAWING NUMBER

1510716: The reproduction, distribution and utilization of this document or its contents to others without express authorization is prohibited. Violations require compensation. All rights reserved in the case of patent, utility, model or design registration.

MACHINE TYPE

SERIAL NUMBER

DIESEL ENGINE OFF GAS TREATMENT
E PLAN

PAGE 91 OF

CREATION DATE 24.11.2021 08:48

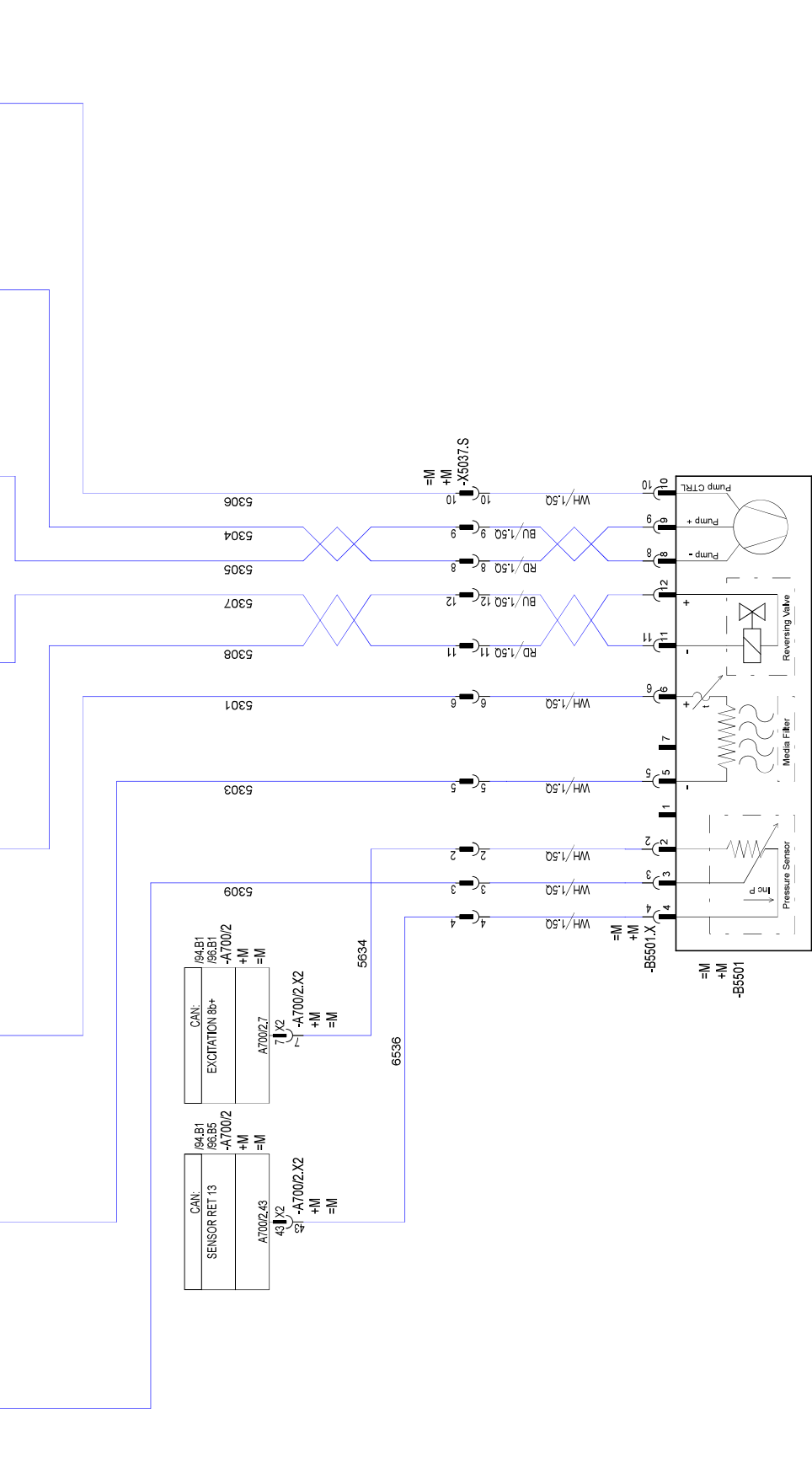
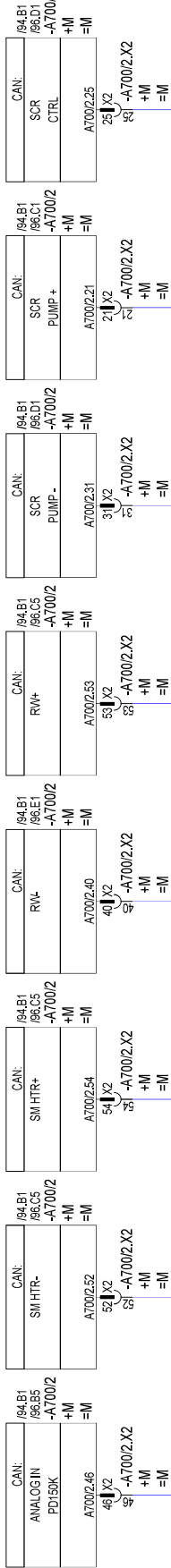

ISO 15705: The reproduction, distribution and/or use of this document without express authorization is prohibited. Violations require compensation. All rights reserved in the case of patent, utility, model or design registration.

1. Diesel generator assignments are for reference only.
2. At Revision: 5/24/21: Sheet 4 and 5 modified for new DEF heater.
3. B1008 (DEF heater) 525026 added to sheet 4.
4. Revised DEF Heater 525026 name: 525015
5. Added DEF Heater 525026: 542415
6. DEF heater 525026 name changed from Extension 19 to Extension 14c. CDE change from 6022 to 5136. 104-15.

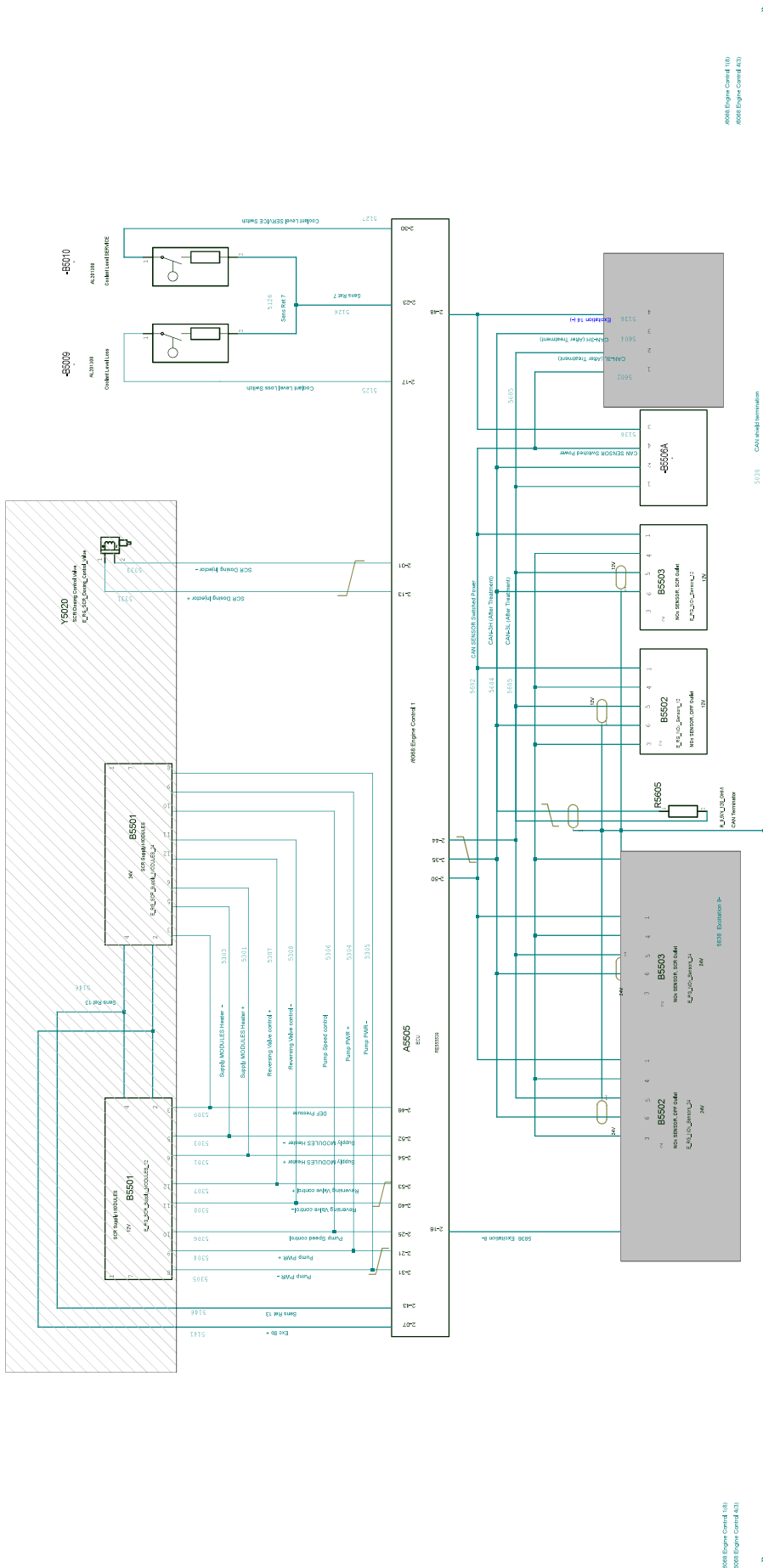

MACHINE TYPE

SERIAL NUMBER

LIEBHERR
FACTORY LBH

CIRCUIT DIAGRAM DIESEL ENGINE
E PLAN

PAGE 101 OF

CREATION DATE

24.11.2021 08:48

The central control unit (Master4) is responsible for the following functions:

- Controlling display
- Controlling CAN bus modules
- Controlling the control units
- Controlling the travel hydraulics
- Controlling the working hydraulics
- Controlling the ride control system
- Controlling the fan system
- Controlling emergency steering pump (if installed)
- Transmission controller
- Brake system controller
- Saving service codes
- Data input and output via diagnostic plug
- Actuating heating and air conditioning controller
- Controlling various options

2.2 Function of the LEDs during operation

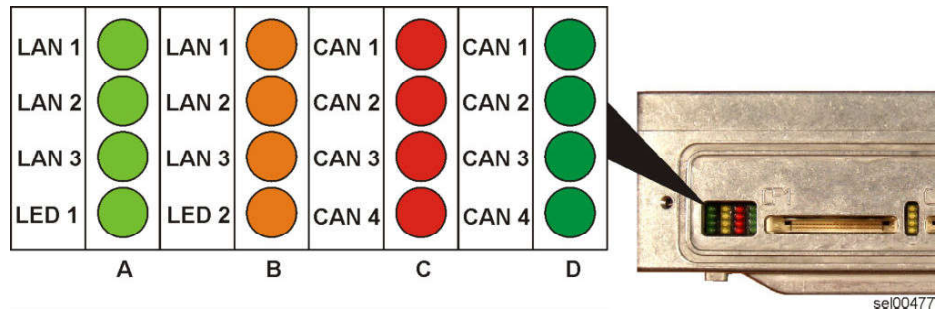

Fig. 498: Function of the LEDs during operation

The LEDs on the central control unit indicate the various transmission statuses.

Transmission mode	LED	Status	Effect
LAN 1 to 3	A	Lights up	Network connected
LAN 1 to 3	B	Flickers	Network traffic
CAN 1 to 4	D	Flickers	Data transfer in progress
CAN 1 to 4	C	Flashes	Transmission error
CAN 1 to 4	C	Lights up	CAN bus stopped

Tab. 239: Function of the LEDs for LAN 1 to 3 and CAN 1 to 4

This operating status of the central control unit is displayed by LED 1 and LED 2.

LED 1	LED 2	Status	Description
On	On	LED test	Directly after the central control unit is switched on, an LED self-test is executed.
Off	Off	Booting	The system is started and waits for all conditions to be met (such as the presence of CAN modules in the system).
Flashes (at 1 s intervals)	Off	Running	The system is running completely (normal operation).

LBH/12204903/13/211-20211019_135919/en

2.5 Analog inputs (IA16)

Analogue inputs 1 to 16 are used for measuring current signals and voltage signals.

Currents of 0-20 mA can be measured.

Voltages of 0-5 V can be measured.

Depending how the software is programmed, the following inputs can be used as analogue inputs (module type IA16) or as digital inputs (module type DE):

- X3.C3
- X3.C4
- X3.E3
- X3.E4

2.6 Digital inputs (DE)

Digital inputs 1 to 22 are used for measuring voltage signals.

Voltages of 0-5 V or 0-54 V can be measured.

Digital inputs only evaluate the status 0 or 1.

2.7 Resistance measurement inputs (IR04)

Resistance values are read via the resistance measurement inputs.

The measuring range for resistance inputs 1 and 2 is 500 to 3000 ohms.

The measuring range for resistance inputs 3 and 4 is 500 to 6000 ohms.

2.8 Frequency measurement inputs (IF04)

Compact module has 4 frequency measurement inputs.

Measuring range of frequency inputs is between 1 Hz and 30 kHz

2.10 Analogue outputs (OA16)

Compact module has a total of 16 analogue outputs.

The 16 analogue outputs consist of 8 analogue outputs with an output current of up to 2 amps and 8 analogue outputs with an output current of up to 4 amps.

Analogue outputs are powered via bank 0 and bank 1.

The analogue outputs are protected against shorting and overload.

The analogue outputs are monitored internally by the electronics. Faults at the outputs are displayed in the Sculi diagnostic software.

2.11 Digital outputs (DA32)

Compact module has a total of 6 digital outputs.

Of 6 digital outputs, 4 have an output current of 2 amps and 2 have an output current of 4 amps.

The digital outputs are powered via bank 0 and bank 1.

The digital outputs are protected against shorting and overload.

The digital outputs are monitored internally by the electronics. Faults at the outputs are displayed in the Sculi diagnostic software.

110.7.2 Camera

Valid for: L518-1655;

(For more information see: [020.9.6 Reversing camera](#), page 020-25)

1 Layout

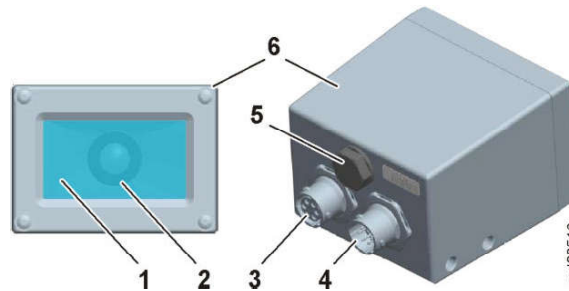

Fig. 519: Camera

- | | | | |
|---|--------|---|-------------------------------|
| 1 | Shim | 4 | Inlet |
| 2 | Lens | 5 | Pressure equalisation element |
| 3 | Outlet | 6 | Housing |

2 Function

After an internal self-test, the camera starts recording on its own. Exposure control is automatic. The resolution of the lens and images is 640 x 480 pixels.

The images are transmitted by Ethernet as data packets in JPEG format. The camera delivers a continuous stream of images at approximately 30 colour images/second, with a colour depth of 3 x 8 bits.

The images on the interface are only sent after this is requested. Several cameras can be linked in succession.

The input 4 of the camera is protected internally against reverse polarity. The output 3 is not protected against overloading or short circuits.

The pressure equalisation element 5 protects the electronics from dust, dirt and moisture. At the same time, it equalises the pressure in the housing, taking the pressure off the seals.

2.2 Plate heater

The camera has an integrated plate heater. This is possible due to a metal coating vaporised onto the inside of the glass plate 1.

Heating power is about 2 W. The temperature is measured internally on the circuit board. The plate heater is switched on at every start (supply greater than 26 V and temperature less than 45 °C). If the voltage is under 25 V or the temperature is over 50 °C, the heating is always switched off.

2 Function

2.1 Basic function

The axle performs the following functions:

- Transmitting torque and engine speed to the wheels.
- Increasing the output torque by gearing down in the crown wheel and planetary gear.
- Braking the machine using the wet disc brake (service brake).

2.2 Self-locking differential

The self-locking differential distributes speed and torque to the left and right wheels. If one wheel is turning faster than the other (for example when cornering), the self-locking differential compensates for this difference. One of the two wheel turns faster than the input by the same amount that the other wheel turns slower.

If one of the wheels loses torque (for example when the wheel spins), the self-locking function intervenes. This automatically brakes the spinning wheel.

2.3 Drum brake

(For more information see: [100.3.1 Drum brake, page 100-10](#))

2.4 Wheel hub

There is a planetary gear in the wheel hub. The planetary gear reduces the speed and increases the torque.

140 Steel parts of the basic machine

Contents

140.1	Vehicle frame	140-2
140.1.1	Articulation bearing <i>L518-1655;</i>	140-2
140.1.2	Articulation lock <i>L518-1655;</i>	140-3

2.1.3 Closing quick coupler

To close the quick coupler, only the quick coupler load sensing signal solenoid valve **3** is energised.

The quick coupler opening solenoid valve **2** applies pressure to the piston side of the quick coupler hydraulic locking cylinder **10**. Also, the quick coupler load sensing signal solenoid valve **3** sends a load sensing signal **6** to the pressure circuit balance in the control valve block.

150.2.2.2 Overview of quick coupler hydraulics

Valid for: L518-1655/51095-;

1 Layout

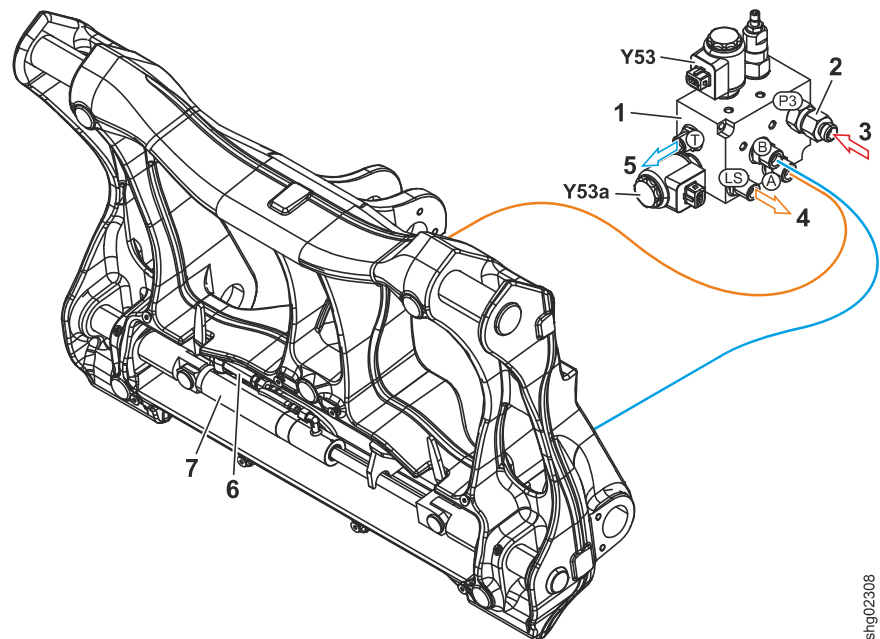

Fig. 537:

- | | |
|---|---|
| 1 Valve block for quick coupler | 5 Return flow to control valve block |
| 2 Check valve | 6 Preload valve 15 bar |
| 3 Oil supply from working pump (via control valve block) | 7 Quick coupler locking hydraulic cylinder |
| 4 Load sensing signal for pressure circuit balance (control valve block) | |

BMK	Function	BMK	Function
Y53	Solenoid for opening quick coupler	Y53a	Quick coupler load sensing signal solenoid

Tab. 267: Equipment codes

Quick coupler hydraulics consist of following components:

- Valve block for quick coupler (For more information see: [Valve block for quick coupler, page 150-9](#))
- Quick coupler locking hydraulic cylinder

LBH/12204903/13/211-20211019_135919/en

shg02308

Function	Adjustment range	Default setting	Information
Delete postscript files			Deletes the currently loaded post-script files. These files are reloaded when the ignition is switched on again.
Edit User Config Data			Adjustment options for INT variables.

Tab. 271: User Configuration menu

2.2.3 Network Configuration menu

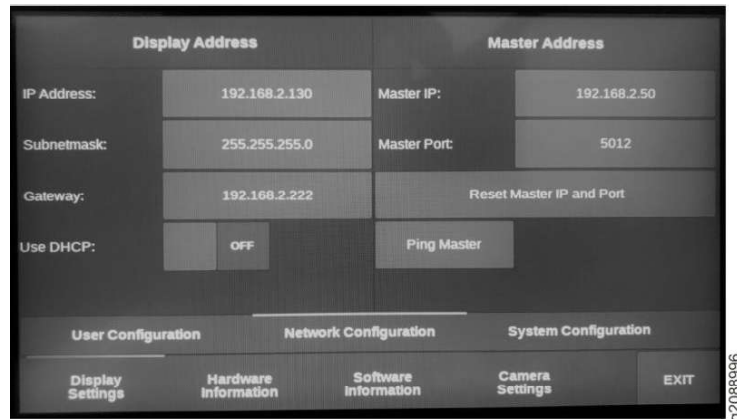

Fig. 546: Network Configuration menu

Function	Adjustment range	Default setting	Information
IP Address		192.168.2.130	IP address of the display. This is automatically selected via the display role. Can be adjusted manually in special cases.
Subnetmask		255.255.255.0	Is set automatically when DHCP = ON.
Gateway		192.168.2.222	Can be ignored for direct connections. Is set automatically when DHCP = ON.
User DHCP	ON, OFF	OFF	The IP address is assigned via an external DHCP server.
Master IP		192.168.2.50	Target IP address to which the display establishes a connection. The IP address of the central control unit (192.168.2.50) is stored in this case by default.
Master Port	0 to 65535	5012	Target port of the target address.
Reset Master IP and Port			Master IP and Master Port are reset to default settings (192.168.2.50 and 5012).

LBH/12204903/13/211-20211019_135919/en

absorbs heat from its environment when it evaporates. This significantly cools the evaporator.

The blower **4** draws in ambient air that is directed through the evaporator. This cools down the air.

The air conditioning pressure switch **12** monitors the pressure in the refrigerant circuit. If the pressure is too low or too high, it deactivates the magnetic coupling and therefore the air conditioning compressor. Switching off when the pressure is too high prevents the air conditioning being damaged. Switching off when the pressure is too low prevents the air conditioning compressor running dry due to there being not enough refrigerant.

The water valve **5** is closed during air conditioning.

Basic function of the air conditioning unit:

2.3 Air conditioning troubleshooting

Malfunction	Cause	Remedy
The air conditioning compressor is switched off for long phases and only switched on for short phases	Cab air filter clogged	Changing cab air filter
	Blower speed is too low	Increase blower speed
	Evaporator is iced up	Check evaporator
	Evaporator fins are dirty	Clean cab evaporator fins
The air conditioning compressor is switched on for long phases and only switched off for short phases, it however fails to cool	Recirculated/fresh air flap set to fresh air	Set flap to recirculated air
	Heating is switched on	Switch off heating
	Outlet nozzles at the front are pointed towards the windscreen	Point outlet nozzles in direction of operator
Air conditioning compressor does not run smoothly	Too much refrigerant in air conditioning circuit	Correct refrigerant level
	Air in air conditioning circuit	Evacuate and refill air conditioning system
	Valve plates in air conditioning compressor are defective	Check valve plates
High-pressure switch switches off	Too much refrigerant in air conditioning circuit	Correct refrigerant level
	Air in air conditioning circuit	Evacuate and refill air conditioning system
	Condenser blocked	Check condenser
Low-pressure switch switches off	Not enough refrigerant in air conditioning circuit	Correct refrigerant level
	Expansion valve blocked	Check expansion valve

LBH/12204903/13/211-20211019_135919/en

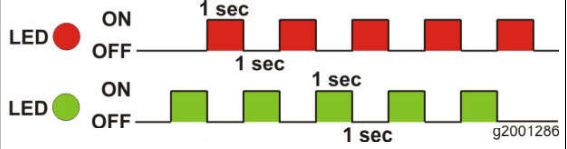
Operating status	Signal description	LEDs
Continuous lubrication (if the lubrication time is set longer than the cycle time)	The red and green LEDs flash alternately every second.	

Tab. 282: Operating statuses

170.1.3 Progressive distributor MX-F

Valid for: L518-1655;

1 Layout

The progressive distributors are manufactured in a variable disc design. The advantage of this is that the distributor can be extended or reduced according to the number of lubrication points.

The flow rate depends on the piston diameter. Each progressive distributor requires at least three pumping elements to work properly.

The progressive distributors of the entire system are coordinated with each other according to the machine type. If a change is made to the combination of the progressive distributors, this can have negative consequences for the entire central lubrication system.

The distributors must always be installed in a horizontal position.

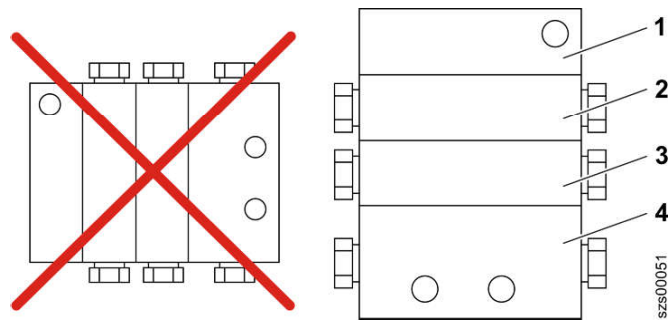

Fig. 578: Installation position of the progressive distributor

- | | |
|-------------------|------------------|
| 1 Initial element | 3 Middle element |
| 2 Middle element | 4 End element |

LBH/12204903/13/211-20211019_135919/en

190.1.4 LiDAT module (LiTU2)

Valid for: L518-1655/0-50943;

1.1 Function

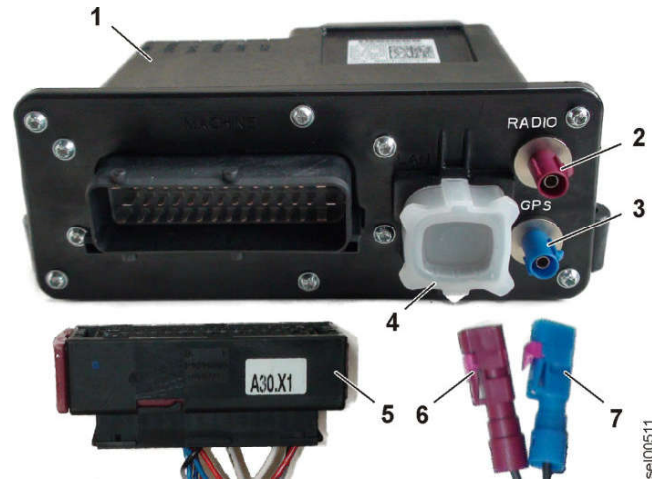

Fig. 586: LiDAT module (LiTU2)

- | | | | |
|---|--|---|-----------------------------------|
| 1 | LiDAT module A30 | 5 | Connector A30.X1 |
| 2 | "RADIO" antenna connection for GSM/GPRS signal | 6 | Antenna cable for GSM/GPRS signal |
| 3 | Antenna connection "GPS" | 7 | Antenna cable for GPS signal |
| 4 | ETHERNET connection | | |





The LiDAT module **1** is connected to the central control unit and the fuse and relay board via the plug A30.X1 **5**.

The antenna cables **6** and **7** are connected to the antenna connections **2** and **3**.

The ETHERNET connection **4** is for connecting to the Sculi diagnostic software.

The Sculi diagnostic software is used to carry out functions such as the following on the LiDAT module:

- Updating software
- Reading service codes
- Creating a service file

Symbol in display	Cause	Effect	Remedy
 	Diesel exhaust fluid level below 10%	None	Checking filling level
	Poor diesel exhaust fluid quality	Diesel engine power reduction	Check service code, check quality of diesel exhaust fluid
 	Diesel exhaust fluid level below 0.5%	Diesel engine power reduction	Checking filling level

Tab. 291: SCR system warning symbols

200.1.3 Service code indicator in the display

The machine control unit monitors many of the machine functions:

- Short circuit
- Cable rupture
- External voltage
- Incorrect input and output signals

The central control unit also continuously checks the program sequence and communication with the control modules.

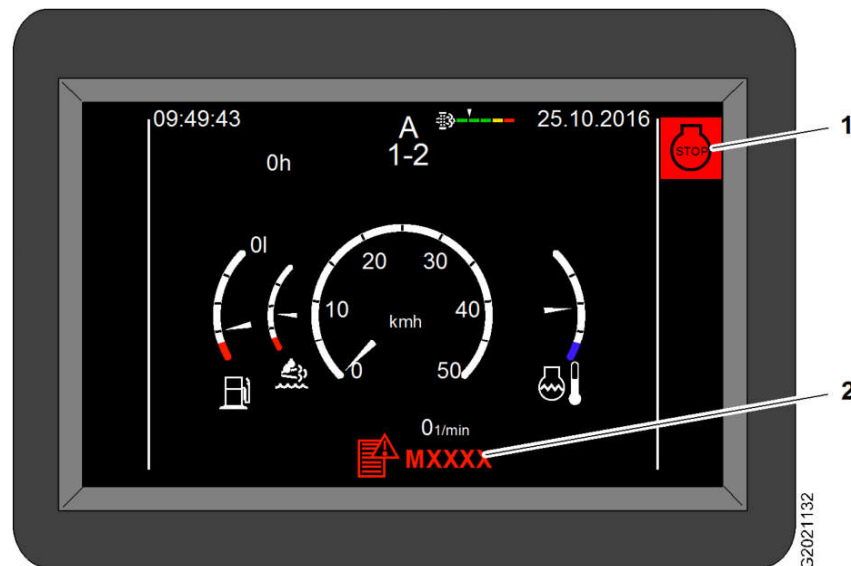

Fig. 616: Service code indicator in the display

- 1 STOP warning symbol 2 Service code display

If an error occurs while you are starting up or operating machine, it is shown in display and stored in memory of central control unit.

The following must be taken into account:

- All service codes can be read using the Liebherr diagnosis software.
- Each service code is accompanied by a single beep.

Malfunctions and their effects

Every malfunction has a defined effect.

Depending on the cause of the error, restricted travel mode may still be possible.

CLICK HERE TO **DOWNLOAD** THE COMPLETE MANUAL

- Thank you very much for reading the preview of the manual.
- You can download the complete manual from: www.heydownloads.com by clicking the link below



- Please note: If there is no response to CLICKING the link, please download this PDF first and then click on it.

CLICK HERE TO **DOWNLOAD** THE COMPLETE MANUAL