

**en**

**Service manual**

Wheel loader

**Document ID**

**Order number:** 11827675  
**Issued:** 06-2019  
**Version:** 07  
**Author:** LBH / Technical Documentation Department

**Product ID**

**Manufacturer:** Liebherr-Werk Bischofshofen GmbH  
**Valid for:** L 507-1259

**Conformity:**



**Contact**

Liebherr-Werk Bischofshofen GmbH  
Dr. Hans Liebherr-Straße 4  
A – 5500 Bischofshofen

CLICK HERE TO **DOWNLOAD** THE COMPLETE MANUAL

- Thank you very much for reading the preview of the manual.
- You can download the complete manual from: [www.heydownloads.com](http://www.heydownloads.com) by clicking the link below



- Please note: If there is no response to CLICKING the link, please download this PDF first and then click on it.

CLICK HERE TO **DOWNLOAD** THE COMPLETE MANUAL

030.4.3.1	Checking the machine for external damage <i>L507-1259/34508-;</i>	030-31
030.4.3.2	Removing loose parts, dirt, ice and snow from the machine <i>L507-1259/34508-;</i>	030-32
030.4.3.3	Cleaning the machine <i>L507-1259/34508-;</i>	030-32
030.4.3.4	Checking the machine for leaks <i>L507-1259/34508-;</i>	030-33
030.4.3.5	Making sure the bolted connections are tight <i>L507-1259/34508-;</i>	030-34
030.4.3.6	Corrosion protection system for use with salt and artificial fertilisers (optional): Carrying out corrosion protection <i>L507-1259/34508-;</i>	030-34
030.4.3.7	Oil analyses <i>L507-1259/34508-;</i>	030-34
030.4.4	Drive group	030-41
030.4.4.1	Checking the engine oil level <i>L507-1259/34508-;</i>	030-41
030.4.4.2	Changing the engine oil <i>L507-1259/34508-;</i>	030-41
030.4.4.3	Changing the engine oil filter <i>L507-1259/34508-;</i>	030-43
030.4.4.4	Checking diesel engine V-belt <i>L507-1259/34508-;</i>	030-44
030.4.4.5	Changing diesel engine V-belt <i>L507-1259/34508-;</i>	030-47
030.4.4.6	Checking the engine valve clearance <i>L507-1259/34508-;</i>	030-49
030.4.4.7	Draining off condensate from the fuel pre-filter <i>L507-1259/34508-;</i>	030-52
030.4.4.8	Changing the fuel pre-filter insert <i>L507-1259/34508-;</i>	030-53
030.4.4.9	Changing the fuel fine filter <i>L507-1259/34508-;</i>	030-55
030.4.4.10	Cleaning the air filter service cover and dust discharge valve <i>L507-1259/34508-;</i>	030-56
030.4.4.11	Checking the air suction system for leaks and tight fitting <i>L507-1259/34508-;</i>	030-57
030.4.4.12	Testing the air filter vacuum switch <i>L507-1259/34508-;</i>	030-58
030.4.4.13	Cleaning or changing the main filter element <i>L507-1259/34508-;</i>	030-59

160.3.1	Overview of the heating, ventilation and air conditioning system <i>L507-1259/34508-;</i>	160-15
160.3.2	Heating and air conditioning unit	160-22
160.3.2.1	Blower <i>L507-1259/34508-;</i>	160-22
160.4	Air conditioning	160-24
160.4.1	Air conditioning (option) <i>L507-1259/34508-;</i>	160-24
160.4.2	Compressor magnetic coupling <i>L507-1259;</i>	160-25
160.4.3	Condenser <i>L507-1259/34508-;</i>	160-27
160.4.4	Dryer <i>L507-1259/34508-;</i>	160-27
160.4.5	Air conditioning pressure switch <i>L507-1259/34508-;</i>	160-29
160.4.6	Evaporator <i>L507-1259/34508-;</i>	160-31
<b>170</b>	<b>Lubrication system</b>	170-1
170.1	Liebherr automatic central lubrication system	170-2
170.1.1	Automatic central lubrication system: General overview <i>L507-1259/34508-;</i>	170-2
170.1.2	Central lubrication pump EP-1 <i>L507-1259/34508-;</i>	170-6
170.1.3	Progressive distributor MX-F <i>L507-1259/34508-;</i>	170-9
<b>190</b>	<b>Options</b>	190-1
190.1	LiDAT	190-2
190.1.1	Overview of LiDAT <i>L507-1259/34508-;</i>	190-2
<b>200</b>	<b>Diagnosis</b>	200-1
200.1	Malfunctions	200-2
200.1.1	Warning symbols	200-2
200.1.2	Service code indicator in the display	200-2
200.2	Troubleshooting	200-5
200.2.1	Replacing fuses	200-5
200.2.1.1	Fuses in the battery compartment	200-5
200.2.1.2	Plug-in fuses on the relay and fuse board	200-6

3. The table at the end of this **operator's manual** states exactly who may carry out each job.  
The jobs listed under **daily / weekly** in the maintenance schedule can be carried out by the operator or by maintenance staff  
The other jobs may only be carried out by suitably qualified specialist staff.
4. Spare parts must meet the technical requirements specified by the manufacturer. This is guaranteed if you use genuine spares. Spare parts which do not meet the manufacturer's technical specifications can impair the safety and reliability of the machine.
5. Wear safety overalls for maintenance work. Certain jobs not only require a hard hat and safety boots, but also safety glasses and safety gloves.
6. Keep unauthorised persons away from the machine during maintenance.
7. Set up an extended cordon around the maintenance area as necessary.
8. Notify the operating personnel before starting repairs or other special jobs. Nominate a supervisor.
9. Unless otherwise specified in the **operator's manual**, carry out all maintenance work on the machine on firm, level ground with the diesel engine off.
10. Afterwards always re-tighten any bolts loosened during maintenance and repair work.
11. If safety equipment has to be dismantled for rigging, maintenance and repair work, it must be re-installed and checked as soon as the job is finished.
12. Before carrying out maintenance work, especially under the machine, attach a warning sign marked **DO NOT SWITCH ON** to the ignition where it is clearly visible. Take out the ignition key.
13. Before starting maintenance or repairs, clean any oil, fuel or service fluids from the machine, especially connections and bolted joints. Do not use abrasive cleaning agents. Use fibre-free cloths.
14. Before welding, burning and sanding, clean any dust from the machine and the area around it, and ensure adequate ventilation.  
There is otherwise a **RISK OF EXPLOSION**.
15. Before cleaning the machine with water, steam jet (high-pressure cleaner) or other cleaning agents, cover or tape up all openings where water, steam and cleaning agent may not penetrate for safety reasons.  
Electric motors, control cabinets and battery compartments are at particular risk.  
  
Further procedure:
  - Make sure that when cleaning the operator's cab, the temperature sensors for the fire alarm and extinguisher systems do not come into contact with hot cleaning agent. Otherwise the fire extinguishing system could be activated.
  - After cleaning, completely remove the covers and tape.
  - After cleaning, check all fuel, engine oil and hydraulic oil lines for leaks, loose connections, abrasion and damage.
  - Repair any defects immediately.
16. Follow the safety instructions for the product in question when handling oil, grease and other chemical substances.
17. Dispose of spare parts and consumables in a safe, environmentally sound manner.
18. Take care when handling hot operating and auxiliary materials (danger of burns and scalding).
19. Only operate combustion engines and fuel-powered heaters in sufficiently ventilated rooms. Before starting the engine inside a building, make sure the room is well ventilated. Follow the local regulations in force at the site.
20. Only carry out welding, burning and grinding work when it is expressly allowed. There may be a risk of fires or explosions, for example.
21. Do not try to lift heavy parts. Only use suitable equipment with sufficient load capacity.

Designation	ID no.	All wheel loaders	Remark
Test probe, black	884191114	All wheel loaders	For measurements at plug connections
Solenoid tester	10028268	All wheel loaders	For testing solenoid valves
Battery plug tool	11839123	All wheel loaders	For opening the plugs on the battery cells
Wiring harness repair and diagnosis set	11113798	All wheel loaders	For repairing and troubleshooting the electrical system
ID numbers for other tools and plug connections of the electrical system can be taken from the wiring harness repair and diagnostic set.			
Wiring harness repair and diagnosis set: Liebherr Service Documentation - General information - wiring harness repair and diagnostic set			

Tab. 5: Special electrical tools

## 010.2.6 Special tools for axles

Designation	ID number	Use	Remark
Handle for driver	10220624	Front axle, rear axle	Holder for driver
Driver 62 mm	10220616	Front axle, rear axle	Fitting the shaft seal ring in the axle casing (T3-2387)
Driver 150 mm	10220615	Front axle	Fitting the shaft seal ring in the wheel hub (T2-2384)
Driver 205 mm	10220622	Rear axle	Fitting the shaft seal ring in the wheel hub (T15-4266)
Driver 66 mm	10220621	Rear axle	Fitting the seal ring of the axle in the axle casing (T14-4210)
Set of 5 spanners	10220617	Front axle, rear axle	Gripping while installing or removing the bevel gear shaft (T5-2386)
Slotted nut spanner with adapter	10220618	Front axle, rear axle	Dismantling and fitting the bevel gear shaft and differential (T6-1332)

Tab. 6: Special tools for axles

## 010.2.7 Special tools for the air conditioning system

Designation	ID no.	Use	Remarks
Valve insert in air conditioning hose filling port	11834778	All wheel loaders	For replacing defective valve inserts. Set of 10
Valve insert remover	11834779	All wheel loaders	For changing valve inserts in the filling port of air conditioning hoses.
Vacuum pump	7027552	All wheel loaders	For evacuating the air conditioning system

## 010.4 Preservation guidelines

### 010.4.1 General information

All parts of a construction machine are exposed to corrosion when out of use. Corrosion can be compared to wear. However, the effects can be much more serious than mechanical wear and can significantly reduce the service life of the parts. This means the machines and their components must be preserved according to certain guidelines when out of use.

Generally these guidelines are based on the following time-scales:

- Out of service for an unknown period of time
- Putting the machine out of service
  - Out of service for up to 2 months
  - Out of service for up to 12 months
  - Out of service for longer than 12 months
- Putting back into service

The required measures are also scaled according to the time periods. The preservation measures are not strictly standardized, and are to be shortened or lengthened depending on necessity (e.g. because of environmental conditions).

Such conditions are, for example:

- The machine's location (e.g. in unprotected open space, in closed space, with roof, temperature-controlled environment)
- The type of climate (e.g. extreme temperatures, storage near the sea or the coast, etc.)

### 010.4.2 Machine out of service for an unknown period of time

If the machine is out of use for a lengthy period without preservation, it must be **put back into service at intervals of no more than 14 days** in order to prevent increased corrosion and the resulting damage.

- All oil levels must be checked before putting into service and filled up where necessary.
- Carry out all the prescribed daily maintenance work every day before putting into service. Carry out all the additional maintenance work subject to time limits as per the inspection plan and the additional diesel engine operator's manual by the specified intervals at the latest.
- Put machine back into service according to operating instructions and operate until the diesel engine and hydraulics system have reached the prescribed operating temperature in the hydraulic tank and in the coolant circulation.
- Activate all the functions of the travel and working hydraulics and of the other hydraulic components, and operate alternately for approx. 20 minutes in total. Hydraulic cylinders must each be extended and retracted over their full stroke length.
- When switching off the machine, retract all the hydraulic cylinders completely if possible, and fill up the fuel tank. If the surface is soft, put the machine on wooden blocks or similar, and secure against rolling.
- Check batteries and, if necessary, remove and recharge. Check electronic contact points and grease with terminal grease if needed.

	Designation	Unit	Value
A	Dumping height at maximum lifting height and 42° tilt-out angle	mm	2550
B	Dump height	mm	2872
C	Maximum bucket base height	mm	3011
D	Maximum bucket pivot point height	mm	3211
E	Maximum bucket upper edge height	mm	4040
F	Reach at maximum lifting height and 42° tilt-out angle	mm	818
F max.	Maximum reach at 42° tilt-out angle	mm	1517
G	Digging depth	mm	80
H	Height above cab	mm	2748
I	Height above exhaust	mm	2600
J	Ground clearance	mm	295
K	Wheelbase	mm	2150
L	Overall length	mm	5295
	Turning radius over bucket outer edge (transport position)	mm	3755
	Breakout force (SAE)	kN	48
	Tipping load when straight	kg	4065
	Tipping load when articulated (ISO 14397-1)	kg	3712
	Operating weight	kg	5470

Tab. 14: Complete machine with bucket

- A) Welded tooth holder with plug-in teeth  
 B) In practice, the bucket capacity can be around 10% greater than as calculated using the ISO 7546 standard. This depends on the type of material.

## 020.1.2 Attachment: Light material bucket with undercut blade

Valid for: L507-1259/34508-;

The values stated refer to the machine:

- In its standard version
- With 365/70 R18 tyres (For more information see: 020.11.4 Tyres, page 020-25)
- Including all lubricants
- With a full fuel tank
- With ROPS/FOPS cab and driver



### Note

The tyres and working attachments affect the operating weight and tipping load.

- Note the information on the tyres and working attachment.

## 020.4 Working hydraulics

### 020.4.1 Working hydraulics pump

Valid for: L507-1259/34508-;

Description	Unit	Value
Displacement per turn	cm <sup>3</sup>	28.2
Flow rate at upper engine speed	l/min	72
Power	kW	24
Weight	kg	10.4

### 020.4.2 Control valve block

Valid for: L507-1259/34508-;

Description	Unit	Value
Spool valve diameter	mm	18
Piston stroke (each way)	mm	7
Piston stroke in float position	mm	12
Weight	kg	18.5

### 020.4.3 Pilot control unit

Valid for: L507-1259/34508-;

Description	Unit	Value
Type		THF 5
Retaining solenoids for bucket return-to-dig Y9 (optional), lift kick-out Y17 (optional), float position Y18 and control lever lock Y62 (optional) - voltage	V	12
Retaining solenoids for bucket return-to-dig Y9 (optional), lift kick-out Y17 (optional), float position Y18 and control lever lock Y62 (optional) - current consumption	A	0.6
Retaining solenoids for bucket return-to-dig Y9 (optional), lift kick-out Y17 (optional), float position Y18 and control lever lock Y62 (optional) - resistance	ohms	18
Weight - without additional control lever (4 outputs)	kg	3.5
Weight - with additional control lever (6 outputs)	kg	4.9

LBH11827675/07/211-20190529\_073924/en

Description	Unit	Value
Weight	kg	22

## 020.11.4 Tyres

Valid for: L507-1259/34508-;

The following table lists all tyres approved by Liebherr for standard use, along with recommended tyre pressures. Certain ground conditions and uses of the machine require the tyre pressure to be adjusted. Precise details are available from the tyre manufacturer, tyre dealer or Liebherr customer service. Tyres not listed in the following table may only be used after consultation with Liebherr customer service.

### NOTICE

Different tyre diameters!  
Damage to the travel drive.

- ▶ The diameter of the tyres on the front and rear axles may not differ by more than 3%.
- ▶ The diameter of the tyres on the left and right wheels may not differ by more than 1.5%.

Size and tread code		Change in operating weight	Width across tyres	Change in height	Tyre pressure		
					FA <sup>A)</sup>	RA <sup>B)</sup>	p - max. <sup>C)</sup>
		kg	mm	mm	bar	bar	bar
Bridgestone 405/70R20 VUT	L2	+120	1930	+47	3.00	2.75	3.75
Dunlop 365/70R18 SPT9	L2	0	1890	0	3.75	2.25	3.75
Dunlop 365/80R20 SPT9	L2	+76	1890	+55	3.00	2.25	3.75
Dunlop 405/70R18 SPT9	L2	+56	1920	+23	3.00	2.00	3.75
Dunlop 405/70R20 SPT9	L2	+112	1920	+49	2.75	2.00	3.75
Dunlop 405/70R20 PG75RCL	L5	+248	1920	+57	4.00	2.25	5.50
Firestone 340/80R18 Duraforce UT	L3	+37	1880	+14	2.80	1.75	4.00
Firestone 365/80R20 Duraforce UT	L3	+96	1900	+52	2.80	1.75	3.75
Firestone 400/70R20 Duraforce UT	L3	+138	1920	+42	2.30	1.50	4.00
Firestone 400/70R20 R8000 UT	L2	+115	1920	+42	2.50	1.80	4.00
Firestone 405/70R18 Duraforce UT	L3	+108	1930	+22	2.80	1.75	3.75
Michelin 9.00R20 XMINED2	L5	+340	1900	+46	3.00	2.00	6.00
Michelin 400/70R20 BIBLOAD	L3	+112	1920	+37	3.00	1.70	4.40
Michelin 400/70R20 XMCL	L2	+128	1930	+43	2.70	1.70	4.00
Mitas 365/70R18 EM-01	L2	+16	1900	-1	4.50	2.75	3.75
Mitas 365/80R20 EM-01	L2	+88	1900	+51	3.75	2.50	3.75

LBH11827675/071211-20190529\_073924/en

030.4.4.9	Changing the fuel fine filter <i>L507-1259/34508-;</i>	030-55
030.4.4.10	Cleaning the air filter service cover and dust discharge valve <i>L507-1259/34508-;</i>	030-56
030.4.4.11	Checking the air suction system for leaks and tight fitting <i>L507-1259/34508-;</i>	030-57
030.4.4.12	Testing the air filter vacuum switch <i>L507-1259/34508-;</i>	030-58
030.4.4.13	Cleaning or changing the main filter element <i>L507-1259/34508-;</i>	030-59
030.4.4.14	Changing the air filter safety element <i>L507-1259/34508-;</i>	030-62
030.4.4.15	Checking the exhaust system for leaks and tight fitting <i>L507-1259/34508-;</i>	030-63
030.4.4.16	Cleaning or changing the diesel particulate filter <i>L507-1259/34508-;</i>	030-64
030.4.5	Cooling system	030-66
030.4.5.1	Checking the coolant level <i>L507-1259/34508-;</i>	030-66
030.4.5.2	Checking the coolant anti-freeze and corrosion inhibitor concentration <i>L507-1259/34508-;</i>	030-67
030.4.5.3	Cleaning the cooling system <i>L507-1259/34508-;</i>	030-71
030.4.5.4	Changing the coolant <i>L507-1259/34508-;</i>	030-72
030.4.6	Working hydraulics	030-75
030.4.6.1	Lubricating the solenoids, universal joints and tappets on the pilot control unit <i>L507-1259/34508-;</i>	030-75
030.4.7	Hydraulic components	030-75
030.4.7.1	Checking the oil level in the hydraulic tank <i>L507-1259/34508-;</i>	030-75
030.4.7.2	Draining off condensate and sediment from the hydraulic tank <i>L507-1259/34508-;</i>	030-77
030.4.7.3	Hydraulic tank - changing the return-suction filter <i>L507-1259/34508-;</i>	030-78
030.4.7.4	Changing the hydraulic tank breather filter <i>L507-1259/34508-;</i>	030-79
030.4.7.5	Changing the oil in the hydraulic system <i>L507-1259/34508-;</i>	030-80

## 030.2 Filling quantities and lubrication chart









### Specifications in the quantity column:

- The values stated for the filling quantities in the table are only guidelines.
- The dipstick and level markings are always mandatory.
- Each time the oil is replaced or topped up, check the level in the unit in question.

Valid for: L507-1259;

### 030.2.1 Recommended lubricants

Valid for: L507-1259/34508-;

Designation	Recommended lubricant	Symbol	Quantity
Diesel engine (with filter change)	Liebherr Motor oil 10W-40 low ash Liebherr Motor oil 5W-30 low ash	 b0000637	10.2 l
Hydraulic system	Liebherr Hydraulic Basic 68 Liebherr Hydraulic Basic 100 Liebherr Hydraulic HVI Liebherr Hydraulic Plus	 b0000636	90 l 55 l
System capacity			
Tank capacity			
Brake system total capacity	Liebherr Hydraulic HVI, ISO VG 46 (32-68)	 G2036203	0.8 l
Transmission	Liebherr Gear Basic 90LS	 b0000767	0.7 l
Front axle differential	Liebherr Gear Basic 90LS	 b0000767	5 l
Front axle wheel hubs	Liebherr Gear Basic 90LS	 b0000767	2 x 0.9 l
Rear axle differential	Liebherr Gear Basic 90LS	 b0000767	3.7 l
Rear axle wheel hubs	Liebherr Gear Basic 90LS	 b0000767	2 x 0.9 l

Tab. 22: Recommended lubricants

LBH11827675/071211-20190529\_073924/en

If a machine is operated for less than 1000 hours a year, an oil sampling is required once a year. Hydraulic oil staying for a long time in the machine should, however, be changed at the latest after four years (mineral oils and fully saturated synthetic esters) and at the latest after six years (Liebherr-Plus oils).

If a machine is inactive for longer than six months, an oil analysis is required before resuming operation.

## Oil analysis

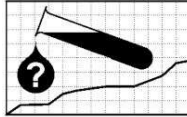

Liebherr recommends having the oil analyses carried out by OELCHECK and carrying out an oil change according to the laboratory report:

- Yellow set for readily biodegradable hydraulic oils
- green set for mineral oils

To take an oil sample: [\(For more information see: Oil analyses, page 030-34\)](#)

See also customer service and product information.

Oil type	Oil sample	
	Not used as bio oil (oil analysis optional)	Used as bio oil (oil analysis prescribed)
Liebherr mineral oil	Every 1000 h	_A)
Liebherr Hydraulic Basic 68		
Liebherr Hydraulic Basic 100		
Liebherr Hydraulic HVI		
Liebherr PAO (polyalphaolefin)	Every 1000 h	First at 0 h then every 1000 h
Liebherr Hydraulic Plus		
Third-party product - mineral oil	First at 1000 h then every 500 h	_A)
Third-party product - fully saturated synthetic ester	_A)	First at 0 h then every 500 h

Tab. 32: Oil sample

A) Combination not permitted

## Changing the filter

Change return filter (only Liebherr filters are permitted)
Every 1000 h

Tab. 33: Changing filters

## 030.3.9 Lubricating oils for axles and transmissions

Valid for: L507-1259/34508-;

Recommended lubricant	Specification
Liebherr Gear Basic 90 LS	API: GL-5

Every time you clean the machine with a high-pressure cleaner, regrease all lubrication points on the machine.

---

**NOTICE**

Beware of damaging the soundproofing mats.  
The soundproofing mats can be damaged if you clean them with high pressure. Damaged soundproofing mats increase the sound output level above that guaranteed by the manufacturer.

- ▶ Do not expose soundproofing mats to water or steam jets.
- 

---

**NOTICE**

There is a risk of damaging electrical devices.  
When using a high-pressure cleaner, you may damage electrical devices such as the emergency steering pump, refuelling pump, sensors and electrical components.

- ▶ Do not expose electrical devices to water or steam jets.
- 

Make sure that the machine is in maintenance position 2.

- ▶ Wash the machine.
- ▶ Regrease all lubrication points on the machine.

### Washing the engine

When washing the engine using water or steam jet, take care not to expose electronic devices such as the starter, alternator, sensors and engine control unit directly to the jet.

After cleaning, start up the engine to allow it to dry out.

---

**NOTICE**

There is a risk of damaging the engine and its electric components.  
Moisture penetration can cause corrosion and electrical malfunctions.

- ▶ Do not expose devices such as the starter, alternator, sensors and engine control unit to water or steam jets.
- 

Make sure that the following requirements are fulfilled:

- The machine is in maintenance position 1.
- The engine compartment hood is open.
- ▶ Carefully clean the engine.

#### 030.4.3.4 Checking the machine for leaks

*Valid for: L507-1259/34508-;*

Make sure that the following requirements are fulfilled:

- The machine is in maintenance position 2.
- The service doors, hatches and hoods are open.
- ▶ Check the hydraulic system for leaks.
- ▶ Replace any damaged hydraulic seals.

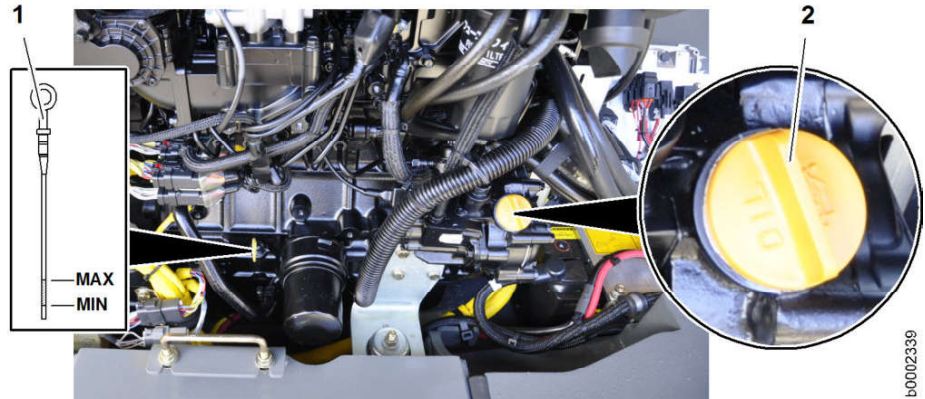

Fig. 46: Checking the engine oil level

1 Dipstick

2 Cap

- ▶ Screw on the cap 2.
- ▶ Fill with fresh engine oil until the oil level is between the MIN and MAX markings on the dipstick 1.
- ▶ Clean the cap 2, place it on the filler neck and tighten it.
- ▶ Start the engine and check the oil pressure.
- ▶ Turn off the engine.
- ▶ Wait for 2 to 3 minutes.
  - ▷ Engine oil collects in the oil pan.
- ▶ Check the oil level on the dipstick. (For more information see: [Checking the engine oil level, page 030-41](#))
  - ▷ Top up with oil if necessary.

### 030.4.4.3 Changing the engine oil filter

Valid for: L507-1259/34508-;

Make sure that the following requirements are fulfilled:

- The machine is in maintenance position 1.
- The service access is open.
- The engine has cooled down.
- You have an oil filter spanner ready.

- The engine has cooled down.

**DANGER**

Beware of fire

- ▶ Naked flames and smoking are prohibited.

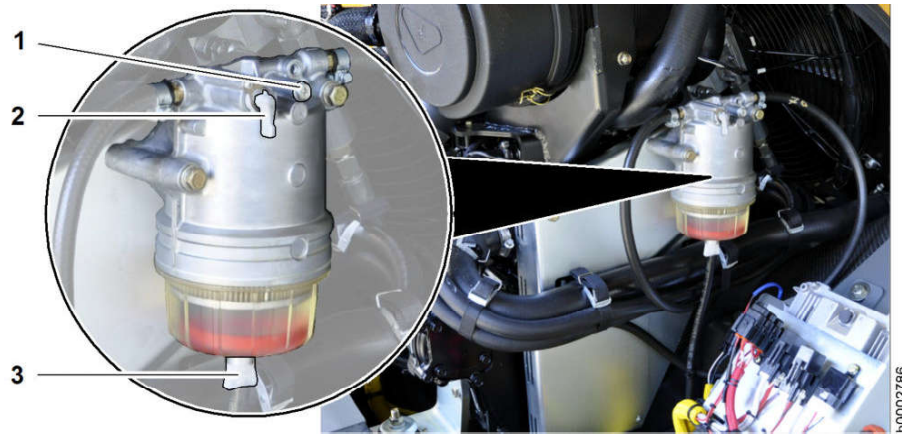

Fig. 57: Draining off condensate from the fuel pre-filter

- |   |                          |   |             |
|---|--------------------------|---|-------------|
| 1 | Bleeder screw            | 3 | Drain valve |
| 2 | Fuel line shut-off valve |   |             |

**Note**

To prevent condensate flowing back into the fuel tank:

- ▶ Open the *fuel line* shut-off valve in front of the drain valve.

- ▶ Place a receptacle under the fuel pre-filter.
- ▶ Close the *fuel line* shut-off valve 2.
- ▶ Open the bleeder screw 1.
- ▶ Open the drain valve 3 until clean fuel flows out.

When clean fuel flows out:

- ▶ Close the drain valve 3.
- ▶ Close the bleeder screw 1.
- ▶ Open the *fuel line* shut-off valve 2.

#### 030.4.4.8 Changing the fuel pre-filter insert

Valid for: L507-1259/34508-;

Make sure that the following requirements are fulfilled:

- The machine is in maintenance position 1.
- The service access is open.
- You have a suitable receptacle ready.
- The engine has cooled down.
- Only use genuine Liebherr spare parts.

### 030.4.4.15 Checking the exhaust system for leaks and tight fitting

Valid for: L507-1259/34508-;

Make sure that the following requirements are fulfilled:

- The machine is in maintenance position 1.
- The service access is open.
- The engine has cooled down.

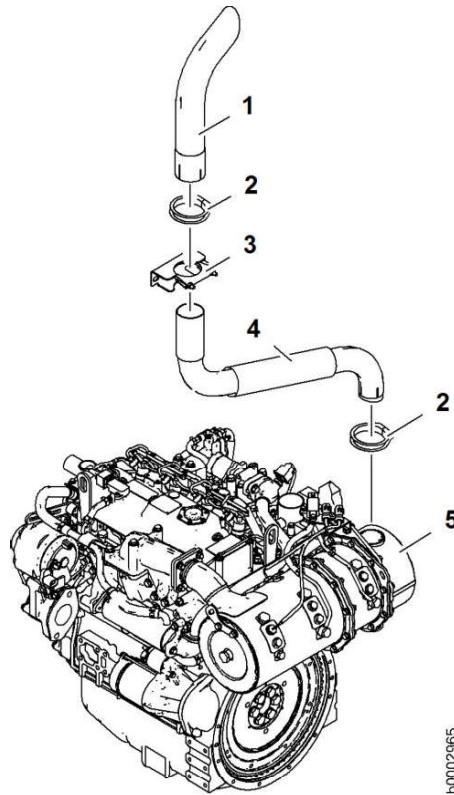

Fig. 70: Checking the exhaust system for leaks and tight fitting

- |   |                |   |                           |
|---|----------------|---|---------------------------|
| 1 | Tailpipe       | 4 | Exhaust pipe              |
| 2 | Clamps         | 5 | Diesel particulate filter |
| 3 | Fastening clip |   |                           |

- ▶ Visually inspect the exhaust system. Look out for traces of soot and damage.
- ▶ Check that the exhaust system is firmly seated.
- ▶ Check the tailpipe **1** and exhaust pipe **4** for cracks and damage.
- ▶ Check that the clamps **2** are tight.
- ▶ Check that the fixing clip **3** is tight.
- ▶ Check that the diesel particulate filter **5** is firmly seated and does not leak.
- ▶ Check the electrical lines of the diesel particulate filter for damage.
- ▶ Check that the temperature sensors are firmly seated and do not leak.
- ▶ Check that the pipes and hoses on the diesel particulate filter are firmly seated and do not leak.
- ▶ Check that the clamps on the diesel particulate filter are firmly seated and do not leak.
- ▶ Start the engine.

- 2 Equalising reservoir  
3 Cooler cap
- 5 Drain valve for coolant



### CAUTION

Risk of scalding due to hot coolant escaping while under pressure.

- ▶ Let the machine cool down.
  - ▶ Carefully open the sealing caps.
- 
- ▶ Carefully open the equalising reservoir cap **1** and the cooler cap **3**.
  - ▶ Carefully open the coolant drain valve **5** and drain the coolant into the receptacle.

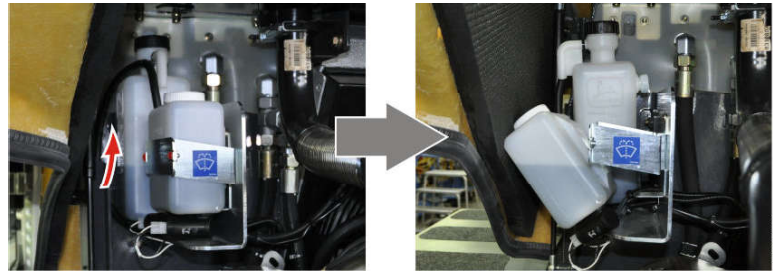

Fig. 82: Removing the equalising reservoir

- ▶ Undo the screws on the windscreen washer fluid reservoir and take it off.
- ▶ Push up the equalising reservoir and unhook it.
  - ▷ You can now remove the equalising reservoir.



### Note

To make it easier to remove the equalising reservoir:

- ▶ Turn the equalising reservoir by 90°.
- 
- ▶ Take out the equalising reservoir and empty it.
  - ▶ Install the equalising reservoir and the windscreen washer fluid reservoir again.
  - ▶ Close the coolant drain valve.

## Filling coolant



### Note

To prepare the coolant:

- ▶ Observe the instructions on the water quality, mixing ratio and anti-corrosion agent. (For more information see: [030.3.7 Coolant, page 030-19](#))
- ▶ Mix coolant before filling the cooling system with the coolant.

**WARNING**

Persons in the danger area!  
Risk of injury.

- ▶ Make sure there is nobody in the danger area.

**Testing the service brake**

Fig. 94: Testing the service brake

- 1 Inching brake pedal
- I Inching
- B Braking

- ▶ Start the machine.
- ▶ Select forward travel direction and drive forward at approximately 8 km/h.
- ▶ While the machine is moving, press the inching brake pedal **1** all the way down.
  - ▷ The machine must come to an abrupt halt.

**Troubleshooting**

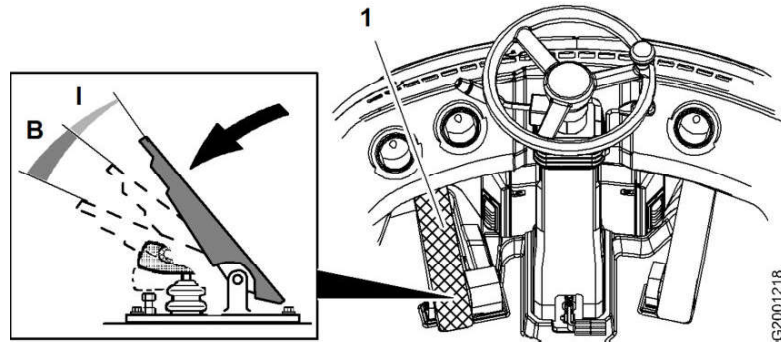
If the braking effect is too slight or entirely absent:

- ▶ Contact Liebherr customer service.

**Testing parking brake**

Fig. 95: Releasing parking brake

- 1 Parking brake
- ▶ Start machine.
- ▶ Select forward travel direction and drive forward at approximately 5 km/h.
- ▶ Activate parking brake **1** button while travelling.
  - ▷ Machine must come to an abrupt halt.

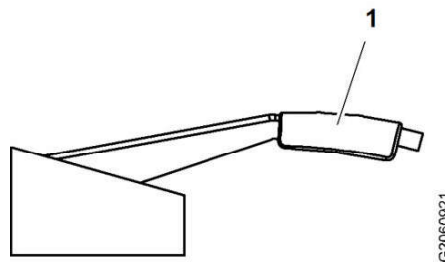
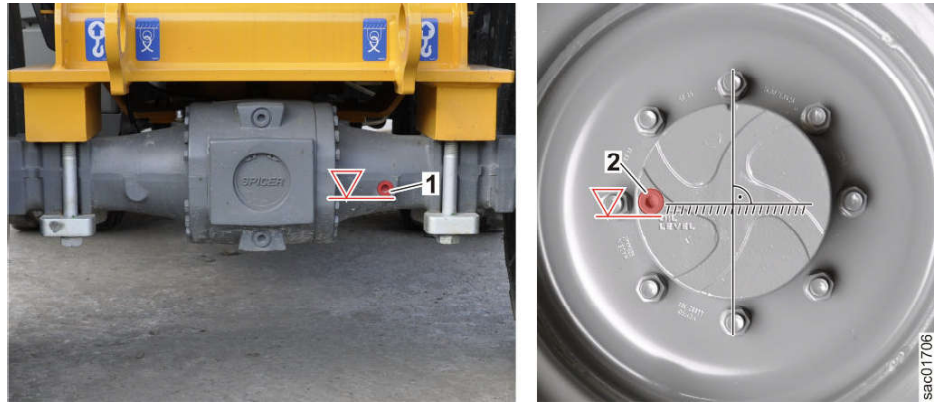

Fig. 105: Checking the axle oil levels, the main housing and wheel hub

### Checking the oil level in the main housing

- ▶ Open the filling plug 1 on the main housing of the front axle.
- ▶ Check whether the oil level is correct (at the bottom of the filling plug 1).

If the oil level is too low:

- ▶ Fill axle oil up to the lower edge of the filling plug 1. (For more information see: [030.2.1 Recommended lubricants, page 030-13](#))
- ▶ Check the axle for oil loss.

If the oil level is correct:

- ▶ Close the filling plug 1.

### Checking the oil levels in the wheel hubs

- ▶ Open the filling plug 2 on the left wheel hub.
- ▶ Check whether the oil level is correct (at the bottom of the filling plug 2).

If the oil level is too low:

- ▶ Fill axle oil up to the lower edge of the filling plug 2. (For more information see: [030.2.1 Recommended lubricants, page 030-13](#))
- ▶ Check the axle for oil loss.

If the oil level is correct:

- ▶ Close the filling plug 2.
- ▶ Start the engine.
- ▶ Position the machine so that the filling plug on the right wheel hub of the front axle is level.
- ▶ Put the machine in maintenance position 2.
- ▶ Repeat the procedure on the right wheel hub.

### Checking the oil levels in the rear axle

- ▶ Repeat the entire procedure on the rear axle (main housing and wheel hub).

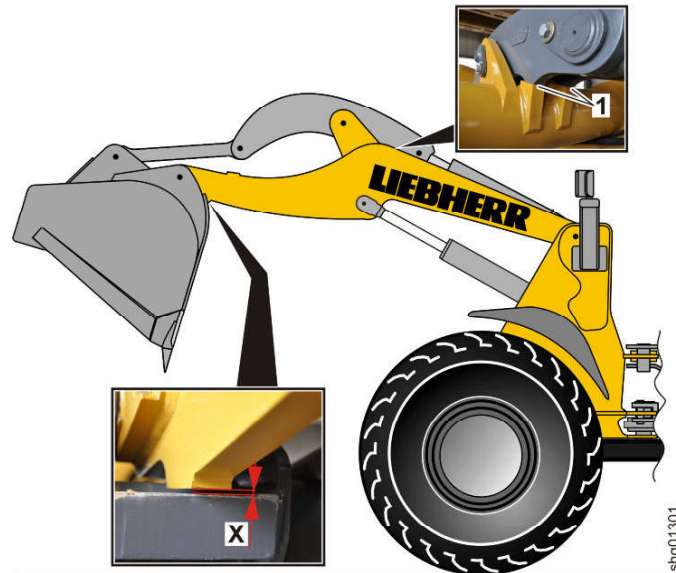

Fig. 119: Checking the lift arm bucket stops

- ▶ Start the engine.
- ▶ Raise the lift arms.
- ▶ Tilt out the bucket until the stops 1 are reached.
- ▶ Turn off the engine and take out the starting key.



#### WARNING

Beware of injury from lift arms lowering.

- ▶ Do not loiter under the lift arms.
  - ▶ Keep people out of the driver's cab.
- 
- ▶ Check the dimension X (also applies for the quick-change device).

Description	Unit	Value
Dimension X	mm	2 <sup>+2</sup>

If dimension X deviates:

- ▶ Contact the technical customer service department.













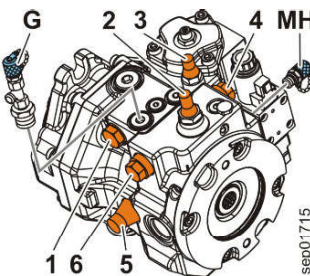
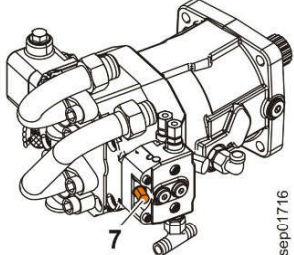























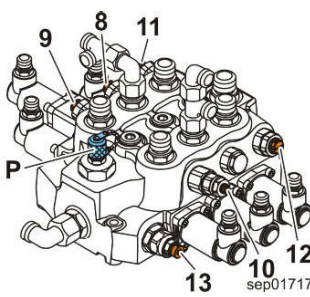





#### 030.4.14.4 Lubricating and testing the quick-change device

Valid for: L507-1259/34508-;

##### Lubricating the quick coupler

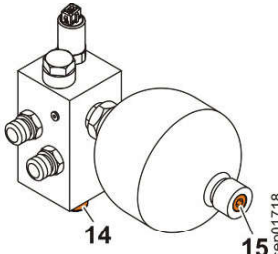
Make sure the following preconditions are met:

- The machine is in maintenance position 2.
- The lubrication point has been cleaned.
- The working attachment is disconnected for lubricating points near the bucket coupler, which are difficult to access.

Test / adjustment	1000 h	2000 h	Unit	Required value	Measured	Adjusted	Adjusting point	Test point	Figure
<b>⇒ Travel pump: Regulation begin</b>  Engine speed at high pressure of 50 bar	○	○	rpm	1050 <sup>±50</sup>			2	MH	 
<b>⇒ Travel pump: Pump power output</b>  Engine speed at high pressure of 400 bar	○	○	rpm	1650 <sup>±100</sup>			5	MH	
<b>⇒ Travel pump: High pressure relief valves</b>  Forward travel direction: High pressure at maximum engine speed <sup>A)</sup>	○	○	bar	490 <sup>±10</sup>			6	MH	
Reverse travel direction: High pressure at maximum engine speed <sup>A)</sup>	◇	◇	bar	490 <sup>±10</sup>			4	MH	
<b>⇒ Travel pump: Pressure cut-off</b>  High pressure at maximum engine speed	○	○	bar	460 <sup>±5</sup>			3	MH	
Engine droop at upper idling speed with active pressure cut-off valve	○	○	rpm	<50					
<b>⇒ Blocked condition</b>  Releasing blocked condition	○	○							
<b>Travel motor: Regulation range</b>  High pressure while accelerating	○	○	bar	270 <sup>±10</sup>			7	MH	
Engine speed while accelerating	○	○	rpm	2200 <sup>±50</sup>					
<b>Working hydraulics</b>									
<b>Control valve block: Secondary pressure relief valves</b>  Opening pressure for lifting <sup>B)</sup>	◇	◇	bar	200 <sup>±5</sup>			8	P	
Opening pressure for tilting in <sup>B)</sup>	◇	◇	bar	200 <sup>±5</sup>			9	P	
Opening pressure for tilting out <sup>C)</sup>	◇	◇	bar	200 <sup>±5</sup>			10	P	
Opening pressure for 3rd function A3 <sup>C)</sup>	◇	◇	bar	205 <sup>±5</sup>			11	P	
Opening pressure for 3rd function B3 <sup>C)</sup>	◇	◇	bar	205 <sup>±5</sup>			12	P	
<b>Control valve block: Primary pressure relief valve</b>  Opening pressure	○	○	bar	230 <sup>±5</sup>			13	P	
<b>Stabilization module (option): Pressure relief valve</b>  Opening pressure	◇		bar	160 <sup>±10</sup>			14	P	

LBH11827675/07211+20190529\_073924/en

- Confirm update or new installation of engine software via Yanmar-Management-Server.

If, due to damage, it is not possible to establish a connection with existing engine control unit, points 1 and 4 are not performed. In this case, specific data (such as operating hours, current loading of DPF, etc.) is lost.



### Note

Software update or new installation on an engine control unit must be confirmed via Yanmar-Management-Server.

As long as updates or new installation of engine software are not confirmed via Yanmar-Management-Server, access to corresponding engine software is blocked for other service technicians.

## Saving setting data of existing engine control unit

Make sure that following requirements are fulfilled:

- Machine is in maintenance position 1.
- Engine control unit is connected to diesel engine.

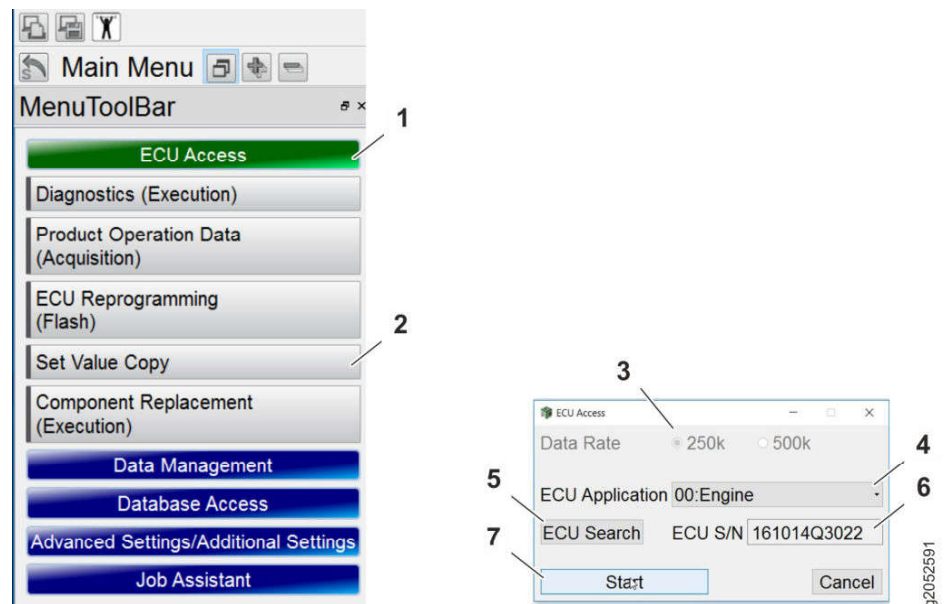

Fig. 137: Connecting SMARTASSIST-Direct diagnostics software to diesel engine

- |   |                         |   |                      |
|---|-------------------------|---|----------------------|
| 1 | ECU Access tab          | 5 | ECU Search function  |
| 2 | Set Value Copy function | 6 | Serial number of ECU |
| 3 | Data Rate function      | 7 | Start function       |
| 4 | Engine function         |   |                      |

- ▶ Switch on battery main switch.
- ▶ Switch on ignition.
- ▶ Run SMARTASSIST-Direct diagnostic software.
- ▶ Select *ECU Access* tab 1.
- ▶ Select *Set Value Copy* function 2.
- ▶ For the *Data Rate* function 3 select a connection speed of 250k.
- ▶ Select *Engine* function 4.

- The service access is open.

Make sure that the following special tools are ready:

- Pressure gauge (250 bar)

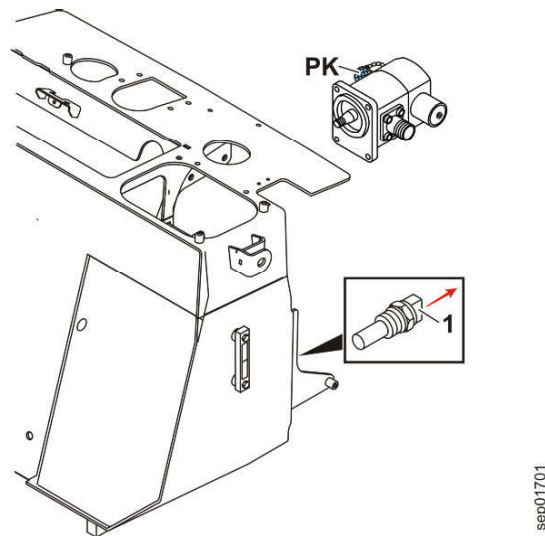

Fig. 154: Fan gear motor: Pressure relief and proportional valve

- ▶ Unplug the hydraulic oil temperature sensor 1.
- ▶ Connect a pressure gauge (250 bar) to the high pressure test connection **PK** on the fan gear motor.
- ▶ Start the engine.
- ▶ Increase the engine speed to the upper idling speed.
- ▶ Check that the high pressure **PK** is correct.

Description	Unit	Value
High pressure <b>PK</b>	bar	100 <sup>±10</sup>

If the value is not correct:

- ▶ Connect the Sculi diagnostic software to the machine.
- ▶ Select the **Cooling system** folder in the hierarchy of the variables editor.
- ▶ Click the variable **Fanlenn** and press the *space bar*.
  - ▷ The line is coloured pink.
  - ▷ A gradual approach towards the required value is possible.



#### Note

To gradually approach the required value:

- ▶ Cursor *up/down*: Last digit of the value +/- 1
- ▶ Cursor *left/right*: Last digit of the value +/- 5
- ▶ Page *up/down* button: Last digit of the value +/- 10

- ▶ Gradually adjust the value of the variable **Fanlenn** at upper idling speed until the value is correct.

### Checking the lift cylinder control valve

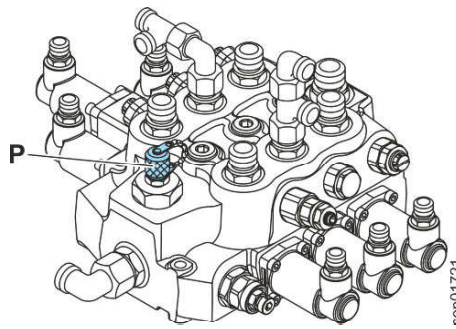

Fig. 160: Working hydraulics pump

- ▶ Connect a pressure gauge (250 bar) to the high pressure test connection P on the control valve block.
- ▶ Start the engine and load the bucket.
- ▶ Raise the lift arms at low idling speed until the pressure shown on the pressure gauge P is 100<sup>+5</sup> bar.



**Note**

If the pressure is not reached:

- ▶ Pressure too low: Load the bucket more.
- ▶ Pressure too high: Load the bucket less.

- ▶ Turn off the engine and take out the ignition key.

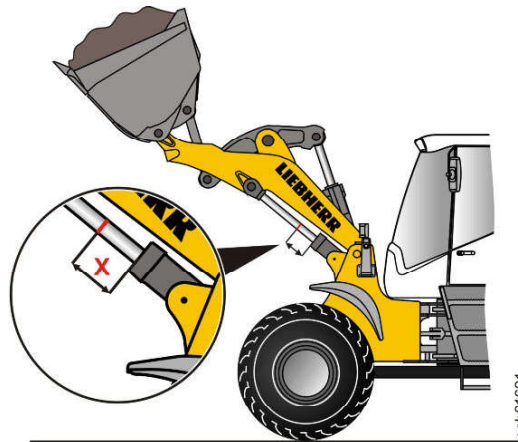

Fig. 161: Marking the position of the lift cylinder

- ▶ On the piston rod of a lift cylinder, mark the distance X = 50 mm to the piston rod bearing.
- ▶ Wait 10 minutes.
- ▶ Measure the distance X between the piston rod bearing and the mark.

Description	Unit	Value
The distance X must be at least	mm	36

LBH11827675/07211+20190529\_073924/en

### 030.6.7.3 Travel pump: Start of regulation

Valid for: L507-1259/34508-;

Make sure that the following requirements are fulfilled:

- The machine is in the maintenance position for testing and adjustment.
- The machine is in the blocked condition.
- The service access is open.

Make sure that the following special tools are ready:

- Pressure gauge (600 bar)

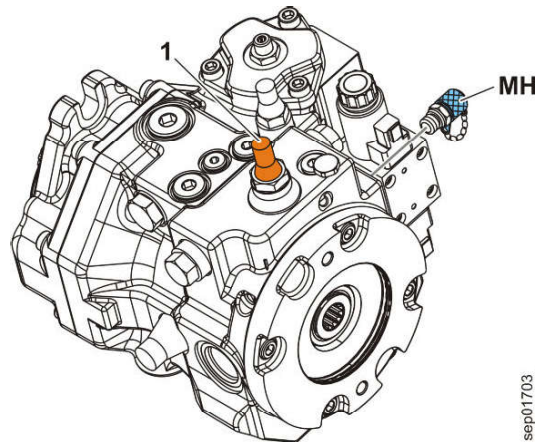

Fig. 173: Travel pump start of regulation

- ▶ Connect a pressure gauge (600 bar) to the high pressure test connection **MH** on the travel pump.
- ▶ Start the engine.



#### WARNING

Unintentional movement of the machine!  
Accidents.

- ▶ Do not let people near the machine.
  - ▶ Be ready to brake when increasing the engine speed.
- 
- ▶ Select forward travel direction and carefully increase the engine speed until the high pressure **MH** reaches 50 bar exactly.
  - ▶ Check that engine speed is correct.

Description	Unit	Value
Engine speed at high pressure of 50 bar	rpm	1050 <sup>±50</sup>

If the value is not correct:

- ▶ Turn off the engine and take out the ignition key.
- ▶ Adjust the adjusting screw of the control valve **1**.

### 030.6.9.2 Inch/brake pedal: Inching valve leakage

Valid for: L507-1259/34508-;

If the driving performance is poor, you can check the inching valve for leaks. If control oil flows into the hydraulic tank without the inch/brake pedal being actuated, the travel hydraulics pump is not moving out to the maximum angle.

Make sure that the following requirements are fulfilled:

- The machine is in the maintenance position for testing and adjustment.

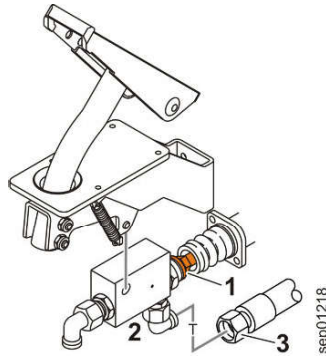

Fig. 181: Inch/brake pedal: Inching valve

- ▶ Unscrew the hose 3 from the tank connection on the inching valve 2.
- ▶ Seal the hose 3 with a blind screw.
- ▶ Start the engine.



#### WARNING

Beware of the machine accidentally moving.  
Accidents.

- ▶ Keep people out of the cab.

- ▶ Check whether oil escapes from the tank connection of the inching valve 2.

If oil escapes from the tank connection:

- ▶ Turn off the engine and take out the ignition key.
- ▶ Adjust the inching valve with the nut and threaded rod 1.

## 030.6.10 Electrical system

### 030.6.10.1 Central control unit (UEC3) Creating a Servicefile

Valid for: L507-1259/34508-;

The service file is a folder where files relevant to the servicing of the machine are kept.

After replacing an electrical or electronic component, a complete service file must be sent to the following e-mail address:

[lbh.maschinenfeedback@liebherr.com](mailto:lbh.maschinenfeedback@liebherr.com)

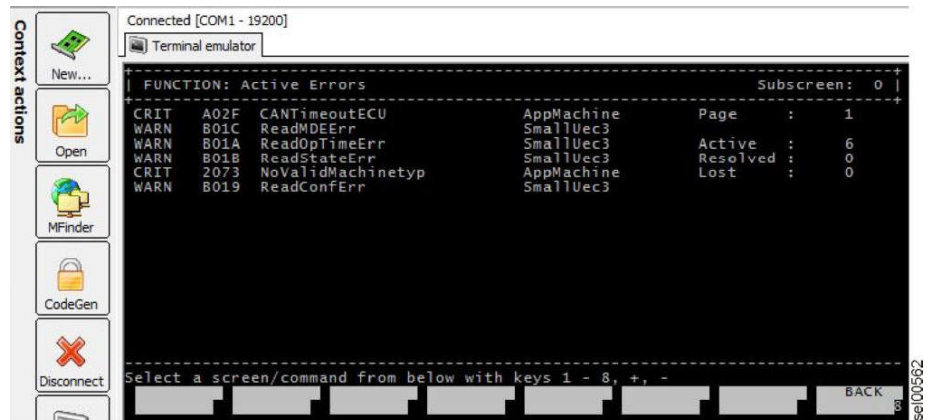

Fig. 198: Service codes screen

You can navigate in the menu bar using the numerical keys.

If service codes are present on the machine, a screen showing them appears. Use the *BACK* button to return to the main screen.

- ▶ Select the *BACK* button.
  - ▷ The main screen appears.

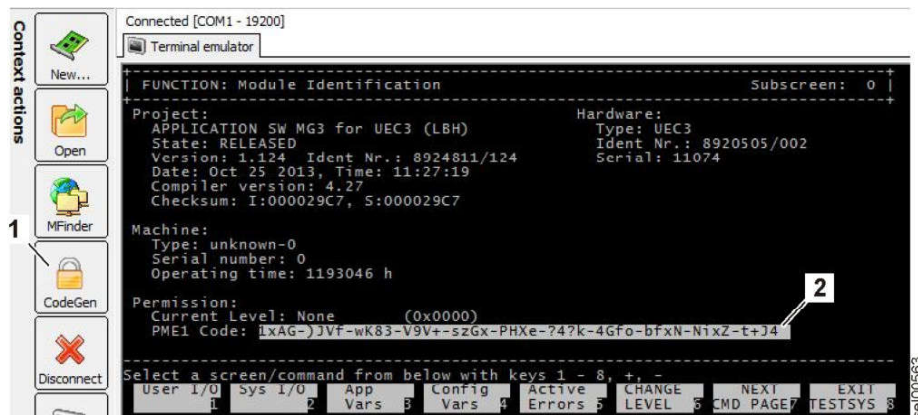

Fig. 199: Main screen

- ▶ Highlight the PME1 Code 2.
- ▶ Right-click to copy the PME1 Code.
- ▶ Open *CodeGen* 1 function.

LBH11827675/07211-20190529\_073924/en

### 2.6 Coolant pump

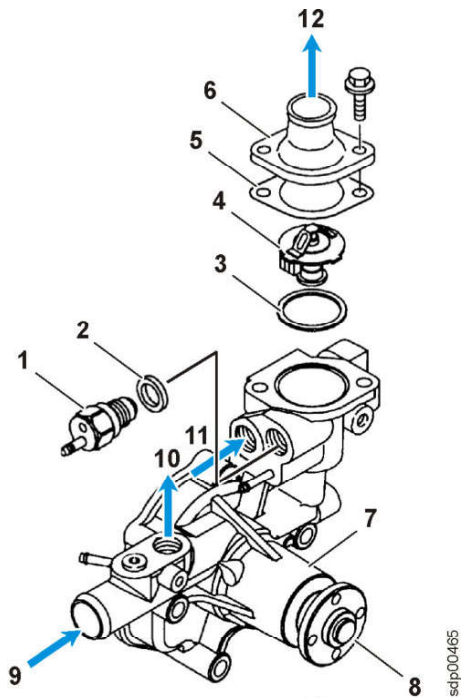

Fig. 209: Coolant pump

- |   |                                |    |                               |
|---|--------------------------------|----|-------------------------------|
| 1 | Coolant temperature sensor B12 | 7  | Pump housing                  |
| 2 | Sealing ring                   | 8  | Pulley drive                  |
| 3 | O-ring                         | 9  | Coolant from radiator         |
| 4 | Thermostat                     | 10 | Coolant to engine block       |
| 5 | O-ring                         | 11 | Coolant from cylinder housing |
| 6 | Thermostat housing             | 12 | Coolant to radiator           |

Coolant pump is driven by a pulley and it pumps coolant through coolant circuit. Thermostat 4 is integrated in coolant circuit.

Coolant temperature sensor 1 measures coolant temperature and sends measured value to engine control unit. Coolant temperature sensor is an NTC resistor. As temperature increases, resistance decreases.

Coolant temperature (°C)	Resistance (kΩ)
20	2.45 <sup>±0.14</sup>
80	0.318 <sup>±0.008</sup>
100	0.1836

Tab. 55: Temperature/resistance of coolant temperature sensor

LBH11827675/071211+20190529\_073924/en

### 040.1.4.1 Air filter system: General overview

Valid for: L507-1259/34508-;

#### 1 Layout

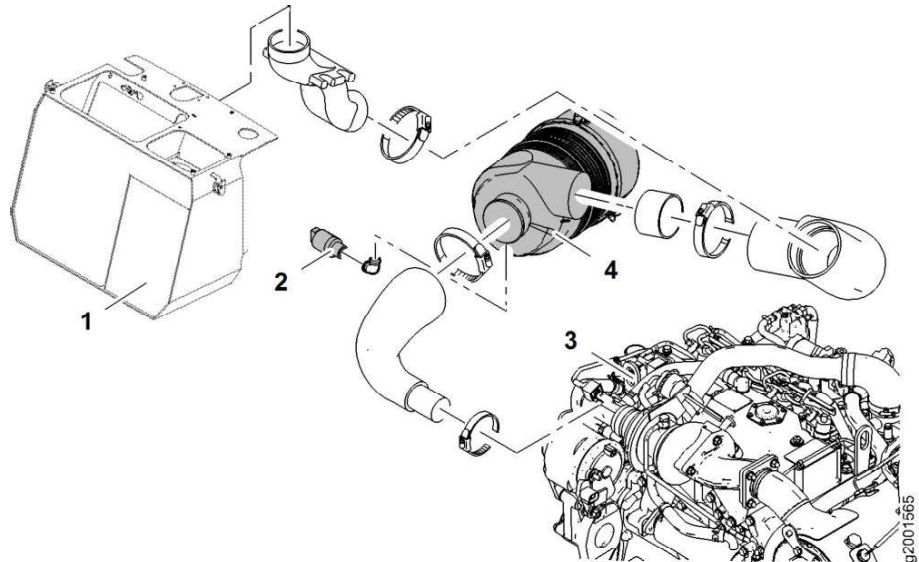

Fig. 219: Air filter system: General overview

- |   |               |   |            |
|---|---------------|---|------------|
| 1 | Cooler mount  | 3 | Engine     |
| 2 | Vacuum switch | 4 | Air filter |

#### 2 Function

For optimum combustion in the engine **3**, it must be supplied with clean intake air.

The intake air flows through the air filter **4**.

The air filter cleans the air, which then passes to the cylinder block.



If the air filter is clogged or too contaminated, a vacuum is produced in the system. The vacuum is measured by the vacuum switch **2**. If the vacuum is too great, the engine control unit triggers a warning sound and a warning symbol on the display.

CLICK HERE TO **DOWNLOAD** THE COMPLETE MANUAL

- Thank you very much for reading the preview of the manual.
- You can download the complete manual from: [www.heydownloads.com](http://www.heydownloads.com) by clicking the link below



- Please note: If there is no response to CLICKING the link, please download this PDF first and then click on it.

CLICK HERE TO **DOWNLOAD** THE COMPLETE MANUAL

# 050 Cooling system

## Contents

050.1	Overview of the cooling system <i>L507-1259/34508-;</i>	050-2
050.2	Cooling system hydraulics	050-4
050.2.1	Overview of the hydraulic control system <i>L507-1259/34508-43314;</i>	050-4
050.2.2	Overview of the hydraulic control system <i>L507-1259/43315-;</i>	050-6
050.2.3	Fan gear pump <i>L507-1259/34508-43314;</i>	050-7
050.2.4	Fan gear pump <i>L507-1259/43315-;</i>	050-8
050.2.5	Fan gear motor <i>L507-1259/34508-43314;</i>	050-9
050.2.6	Fan gear motor <i>L507-1259/43315-;</i>	050-10
050.3	Cooling system electronics	050-12
050.3.1	Electronic control system – general overview <i>L507-1259/34508-;</i>	050-12
050.3.2	Hydraulic oil temperature sensor <i>L507-1259/34508-;</i>	050-13

## 2.2 Pressure relief and proportional valve

The proportional pressure relief valve performs the following tasks:

- Protection from excess pressure
- Regulating the output speed
- Fail-safe function for the electric components of the cooling system

### 2.2.1 Protection from excess pressure

The proportional pressure relief valve protects the hydraulic control unit of the cooling system from excess pressure.

The proportional pressure relief valve functions as a pilot-controlled pressure relief valve. If the pressure is too high, the proportional pressure relief valve opens and directs the oil past the gear motor.

### 2.2.2 Regulating the output speed

The proportional pressure relief valve regulates the output speed by directing oil past the gear motor. To do this, the central control unit energises the proportional solenoid Y13. The higher the current to the proportional solenoid, the wider the proportional pressure relief valve opens.

### 2.2.3 Fail-safe function

When it is not energised, the proportional pressure relief valve is closed. Consequently, the maximum amount of oil flows through the fan gear motor if the electrical system fails. The fan gear motor turns at maximum speed.

## 060.2 Working hydraulics pump

Valid for: L507-1259/34508-;

### 1 Layout

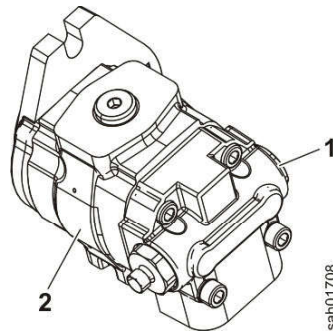

Fig. 247: Working hydraulics pump

1 Priority valve

2 Gear pump

The working hydraulics pump is flange-mounted on the drive shaft of the travel pump.

The working hydraulics pump is an external gear pump.

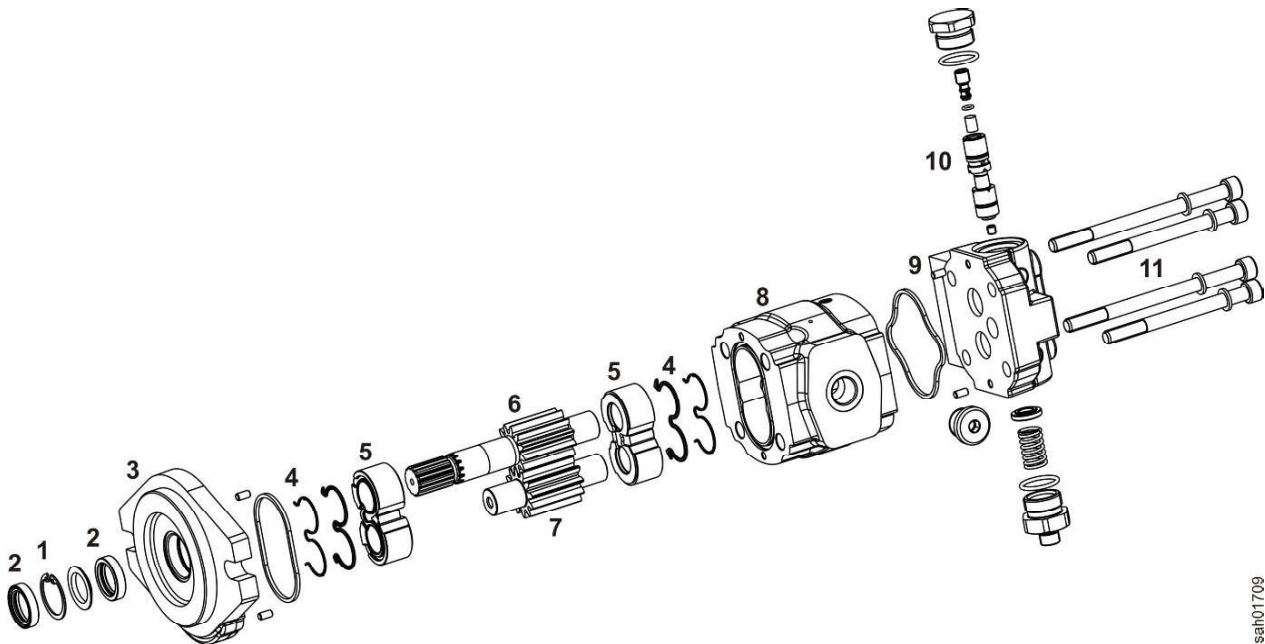

Fig. 248: Exploded drawing of the working hydraulics pump

1 Snap ring

2 Shaft seal ring

3 Pump cover with flange

4 O-ring with support ring

5 Bearing bushing

6 Drive gear

7 Gearwheel

8 Pump housing

9 Connecting housing

10 Priority valve

11 Allen screws

LBH11827675/07211-20190529\_073924/en

sah01709

## 060.4 Pilot control

### 060.4.1 Overview of the pilot control unit

Valid for: L507-1259/34508-;

#### 1 Layout

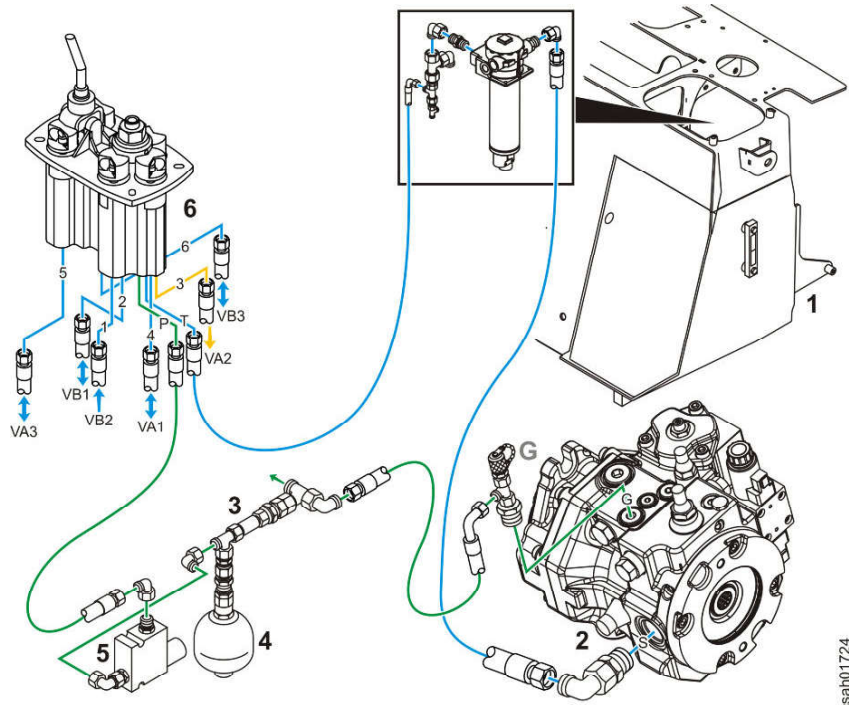

Fig. 261: Pilot control

- |   |   |   |                                       |
|---|---|---|---------------------------------------|
| 1 | Hydraulic tank                                | 5 | Pilot control hydro accumulator       |
| 2 | Travel pump                                   | 6 | Pilot control unit                    |
| 3 | Check valve                                   | G | Replenishing pressure test connection |
| 4 | Working hydraulics lockout solenoid valve Y14 |   |                                       |

The pilot control consists of the following components:

- Hydraulic tank (For more information see: 080.1.1 Overview of the hydraulic tank, page 080-2)
- Travel pump (For more information see: 070.3 Travel pump, page 070-11)
- Pilot control unit (For more information see: 060.4.2 Pilot control unit, page 060-18)
- Working hydraulics lockout solenoid valve Y14 (For more information see: 060.4.3 Working hydraulics lockout solenoid valve, page 060-23)
- Pilot control hydro accumulator (For more information see: 060.4.4 Pilot control hydro accumulator, page 060-24)

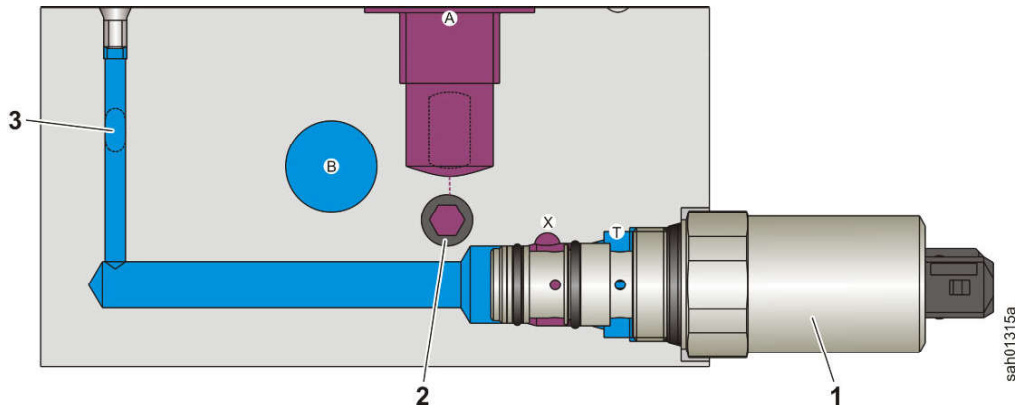

Fig. 274: Sectional view of ride control solenoid valve

- |  |                                 |                                   |
|--|---------------------------------|-----------------------------------|
| <b>1</b> Ride control solenoid valve Y20 | <b>2</b> Restrictor check valve | <b>3</b> Ride control valve spool |
|--|---------------------------------|-----------------------------------|

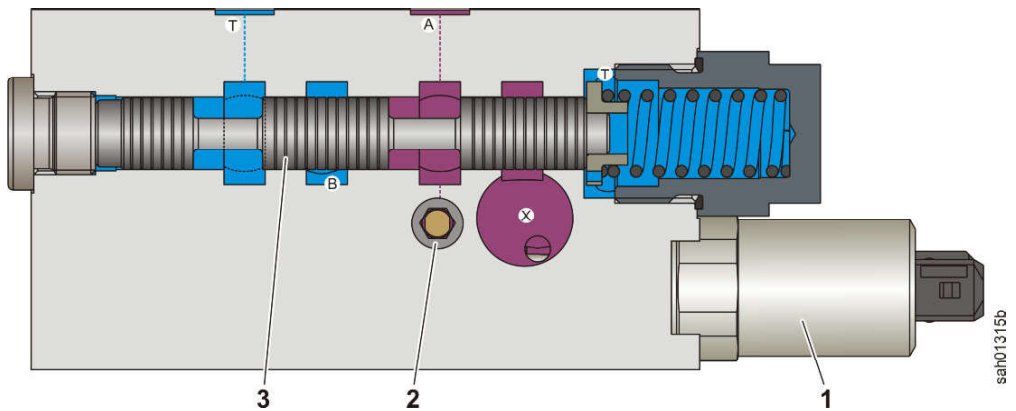

Fig. 275: Sectional view of ride control valve spool

- |  |                                 |                                   |
|--|---------------------------------|-----------------------------------|
| <b>1</b> Ride control solenoid valve Y20 | <b>2</b> Restrictor check valve | <b>3</b> Ride control valve spool |
|--|---------------------------------|-----------------------------------|

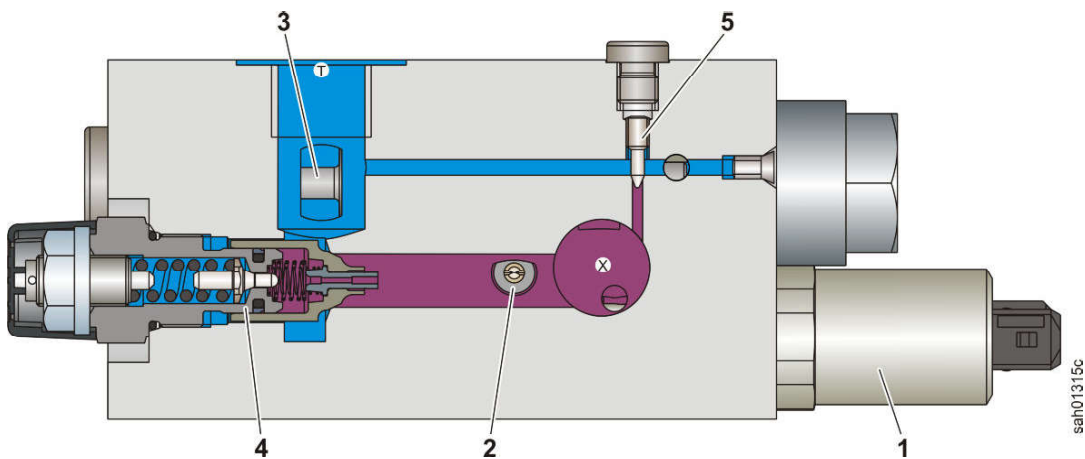

Fig. 276: Sectional view of pressure relief valve

- |  |                                   |                       |
|--|-----------------------------------|-----------------------|
| <b>1</b> Ride control solenoid valve Y20 | <b>3</b> Ride control valve spool | <b>5</b> Relief valve |
| <b>2</b> Restrictor check valve          | <b>4</b> Pressure relief valve    |                       |

LBH1182765/07211+20190529\_073924/en

When the High Flow function is activated, the central control unit energises the High Flow solenoid valve **94**, stopping the connection to the hydraulic tank **1**. The oil from the High Flow gear pump **91** flows through the check valve **93** to the control valve block **55**.

<b>11</b>	Control valve block return flow	<b>34a</b>	Reverse travel direction solenoid Y3	<b>56</b>	In-line filter 80 µm
<b>12</b>	Inch/brake unit return flow (Speeder)	<b>34b</b>	Forward travel direction solenoid Y2	<b>60</b>	<b>Fan gear motor</b>
<b>13</b>	Pilot control unit return flow	<b>35</b>	Swivel restrictor	<b>61</b>	Gear motor
<b>14</b>	Hydraulic oil temperature sensor B8	<b>36</b>	Diesel engine	<b>62</b>	Proportional pressure relief valve Y13
<b>15</b>	Drain valve	<b>37</b>	Orifice Ø1.0 mm	<b>63</b>	Replenishing valve
<b>16</b>	Working hydraulics pump suction port	<b>38</b>	Pilot control	<b>64</b>	Check valve
<b>17</b>	Parking brake solenoid valve block return flow (Speeder)	<b>39</b>	Brake system (Speeder)	<b>65</b>	Hydraulic oil cooler
<b>18</b>	Servostat return flow	<b>40</b>	<b>Travel motor</b>	<b>X1</b>	Forward travel direction control pressure
<b>20</b>	<b>Travel pump</b>	<b>41</b>	Pressure relief valve	<b>MH</b>	Travel hydraulics high pressure
<b>21</b>	Replenishing pump (internal gear pump)	<b>42</b>	Orifice	<b>G</b>	Replenishing pressure
<b>22</b>	Towing bypass valve	<b>43</b>	Discharge valve	<b>M1</b>	Travel motor servo pressure
<b>23</b>	Shuttle valve	<b>44</b>	Positioning piston	<b>PK</b>	Cooling system high pressure
<b>24</b>	Pressure cut-off valve	<b>45</b>	Swivel restrictor		

The travel hydraulics is a closed circuit. This means that after leaving the consumers (travel motor **40**), the oil flows directly back to the pump (travel pump **20**).

The travel hydraulics function hydrostatically. The travel pump converts the rotary movement of the engine into a piston stroke movement (axial piston pump **29**). The piston stroke pumps the oil. The travel motor also uses a piston stroke movement to convert the flow of oil back to a rotary movement (axial piston motor **50**). There is no slip with this kind of drive.

Leakages in the rotary groups and the discharge **41** of the travel motor mean that oil constantly flows out of the closed circuit. This oil is cooled in the hydraulic oil cooler **65** and returned to the hydraulic tank **1**.

The replenishing pump **21**, replaces the missing oil. To do this, the replenishing pump **21** draws up oil from the hydraulic tank **1** and pumps it to the closed circuit on the low pressure side.

Some of the oil returning from the fan gear motor **60** flows to the leak oil connection of the travel motor **40**. This oil lubricates and cools the travel motor **40**. As well as this, oil flows from the replenishing pump **21** to lubricate and cool the travel motor **40**.

## 2.2 Travel direction

The travel direction is determined by the flow direction of the oil in the closed circuit. To change the travel direction, the travel pump changes the direction of flow and this swaps the high and low pressure. The travel pump moves to the zero position.

## 2.3 Regulation

### 2.3.1 Regulation of the travel pump

The travel pump is regulated according to the engine speed (DA regulation). The higher the engine speed, the further the variable displacement pump in the travel pump moves out.

Oil is pumped through a hole in the pistons **9** into the space between the glide shoe and swivel plate. This means the slide shoe floats on a film of oil and slides over the swivel plate without mechanical contact.

The rotary group also slides on a film of oil. This is produced by the leakage between the control lens and the rotary group cylinder.

#### 2.4.2 Swivel plate

The swivel plate **2** lies on a roller bearing, the swivel plate bearing **3**, and is connected by a lever to the servo cylinder **1**.

If the servo cylinder is moved, this changes the lateral angle of the swivel plate to the drive shaft **4**. The angle can be between  $-20^\circ$  and  $0^\circ$  and  $+20^\circ$ .

The tilt of the swivel plate means the pistons **9** perform a lengthways movement axially to the drive shaft with every revolution. This lengthways movement draws up and pumps the oil. The greater the angle, the longer the stroke and the more oil is pumped with each revolution.

If no travel direction is selected (neutral travel direction), the angle of the swivel plate is  $0^\circ$ . The pistons do not perform a stroke movement. No oil is pumped.

#### 2.4.3 Control lens

The restoring force on the high pressure side can be adjusted using the control lens **14**. The control lens is turned with the eccentric adjusting screw **13**. This moves the recesses in the control lens and adjusts the size of the area which the high pressure acts on.

#### 2.5 Regulation of the variable displacement pump

The flow rate depends on the following factors:

- Plate angle
- Engine speed

The swivel plate angle depends on the following factors:

- Selected travel direction (travel direction valve)
- Engine speed (speed-dependent regulation)
- Load (operating pressure)
- Inching function

## 2 Function

### 2.1 Basic function

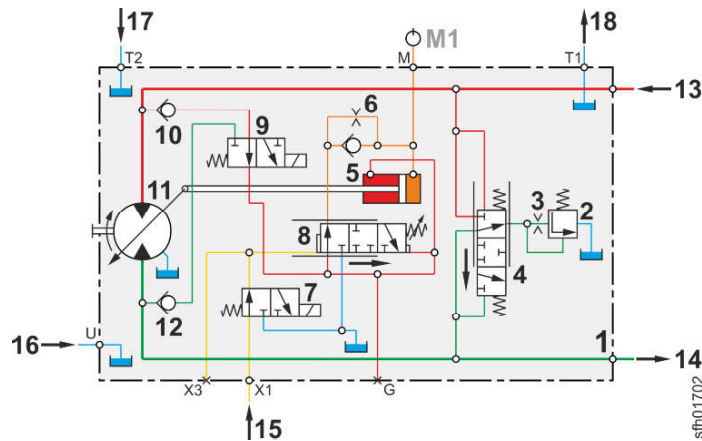

Fig. 308: Hydraulic diagram of travel motor (forward travel direction)

1	Travel motor	11	Inclined axis variable displacement motor (axial piston motor)
2	Pressure relief valve	12	Check valve
3	Orifice	13	High pressure from travel pump
4	Discharge valve	14	Low pressure to travel pump
5	Servo piston	15	Travel pump control pressure
6	Swivel restrictor	16	Travel motor bearing flushing
7	Travel range 1 solenoid valve Y6	17	Fan gear motor return flow
8	Control piston	18	Leak oil to the hydraulic oil cooler
9	Travel motor direction solenoid valve Y26	M1	Travel motor servo pressure
10	Check valve		

The travel motor is driven by the travel pump in a closed circuit. This means that the oil that drives the travel motor flows back directly to the travel pump.

If the high pressure side **13** and the low pressure side **14** are swapped, the direction of rotation of the travel motor changes.

#### 2.1.1 Output speed and output torque

The output speed and output torque depend on:

- High pressure
- Swivel plate angle

At a small angle, the variable displacement motor has a low displacement. This means the output speed is high (only a little oil is required for each revolution). At the same time, the output torque is low, due to the small angle of the pistons to the output shaft.

At a large angle, the variable displacement motor has a high displacement. This means the output speed is low (a lot of oil is required for each revolution). At the same time, the output torque is high, due to the large angle of the pistons to the output shaft.

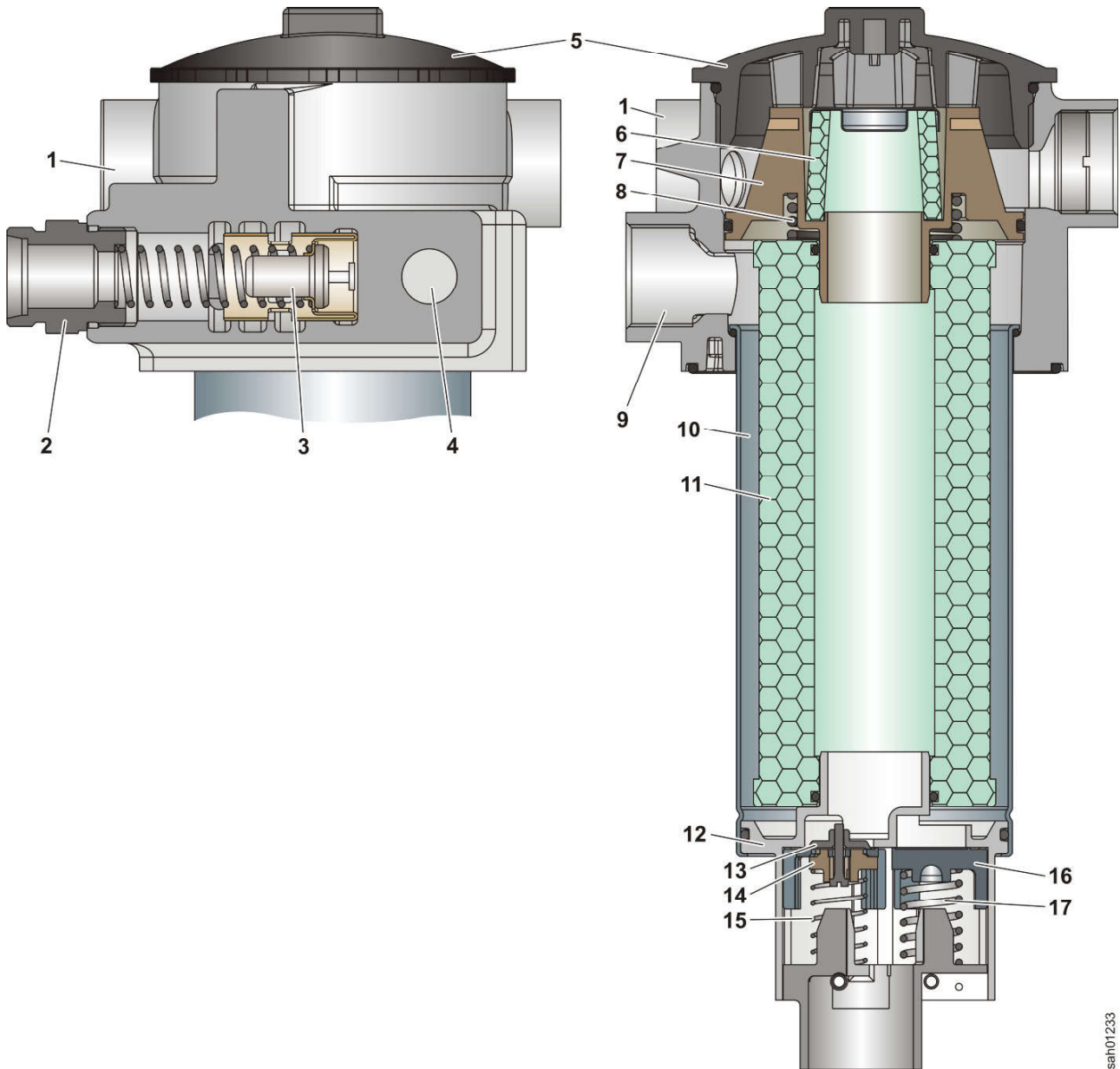

Fig. 317: Sectional view of the temperature valve and filter unit

- |   |                                |    |                        |    |                    |
|---|--------------------------------|----|------------------------|----|--------------------|
| 1 | Replenishing pump suction port | 7  | Filter separator plate | 13 | Replenishing valve |
| 2 | Travel hydraulics leak oil     | 8  | Compression spring     | 14 | Pre-tension valve  |
| 3 | Temperature valve              | 9  | Return oil             | 15 | Compression spring |
| 4 | Return oil                     | 10 | Filter casing          | 16 | Bypass valve       |
| 5 | Filter cover                   | 11 | Return suction filter  | 17 | Compression spring |
| 6 | Strainer                       | 12 | Filter base            |    |                    |

sah01233

LBH1182765/07211-20190529\_073924/en

2 Function

2.1 Basic function

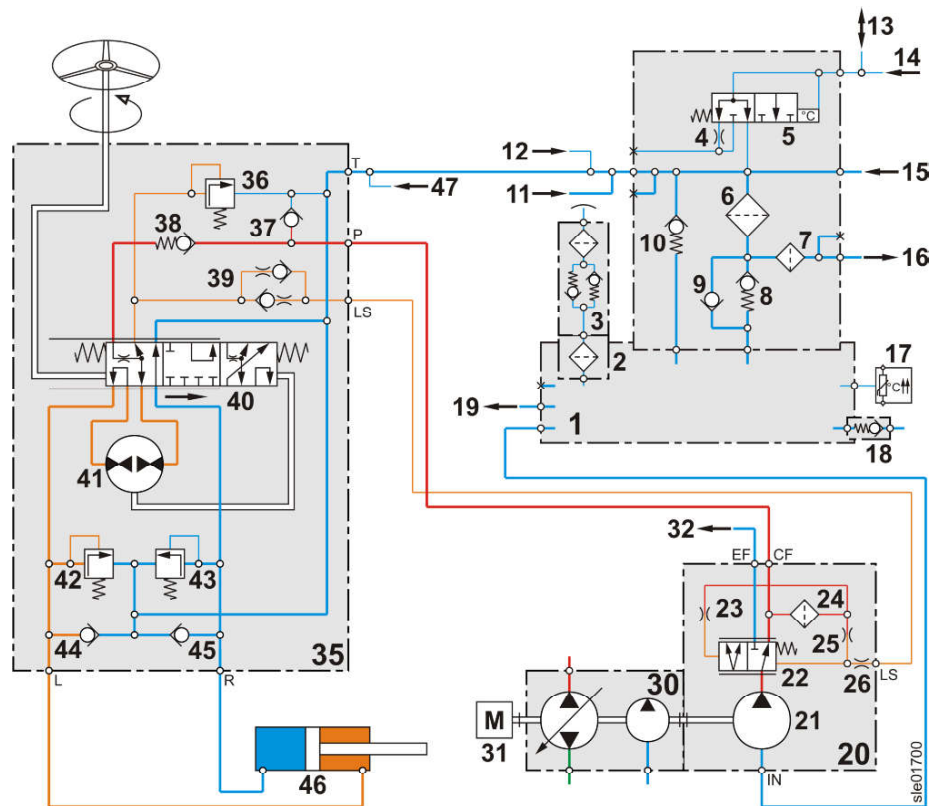

Fig. 326: Hydraulic diagram of the steering system (steer to the left)

- |    |                                     |    |   |
|----|-------------------------------------|----|---|
| 1  | <b>Hydraulic tank</b>               | 22 | Priority valve  |
| 2  | Filler strainer                     | 23 | Restrictor  |
| 3  | Breather filter                     | 24 | Filter  |
| 4  | Restrictor                          | 25 | Restrictor  |
| 5  | Temperature valve                   | 26 | Restrictor  |
| 6  | Return suction filter               | 30 | <b>Travel pump</b>  |
| 7  | Strainer                            | 31 | Engine  |
| 8  | Pre-tension valve                   | 32 | Control valve block oil supply                            |
| 9  | Replenishing valve                  | 35 | <b>Servostat</b>  |
| 10 | 2.5 bar bypass valve                | 36 | LS pressure relief valve                                  |
| 11 | Control valve block return flow     | 37 | Replenishing valve  |
| 12 | Pilot control unit return flow      | 38 | Check valve   |
| 13 | Hydraulic oil cooler bypass         | 39 | Restrictor check valve                                    |
| 14 | Travel pump leak oil                | 40 | Valve spool   |
| 15 | Hydraulic oil cooler return flow    | 41 | Metering pump   |
| 16 | Replenishing pump suction port      | 42 | Secondary pressure relief valve for steering to the left  |
| 17 | Hydraulic oil temperature sensor B8 | 43 | Secondary pressure relief valve for steering to the right |
| 18 | Drain valve                         | 44 | Replenishing valve  |
| 19 | Fan gear pump suction port          | 45 | Replenishing valve  |
| 20 | <b>Working hydraulics pump</b>      | 46 | Steering cylinder   |
| 21 | Gear pump                           | 47 | Inching valve return flow                                 |

LBH11827675/07211-20190529\_073924/en

## 100.2 Service brake and parking brake

### 100.2.1 Drum brake

Valid for: L507-1259/34508-;

#### 1 Layout

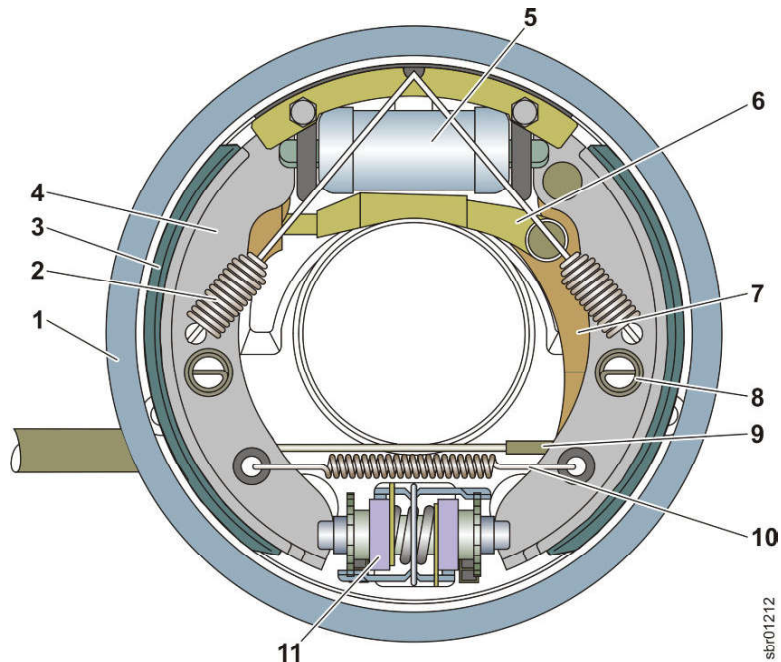

Fig. 332: Drum brake

- |   |                      |    |                            |
|---|----------------------|----|----------------------------|
| 1 | Brake drum           | 7  | Parking brake linkage      |
| 2 | Tension spring       | 8  | Retaining spring           |
| 3 | Brake lining         | 9  | Parking brake bowden cable |
| 4 | Brake shoe           | 10 | Return spring              |
| 5 | Brake cylinder       | 11 | Adjuster                   |
| 6 | Parking brake spacer |    |                            |

The drum brake is flange-mounted on the front axle. The brake drum 1 is connected to the axle input shaft. The other parts of the drum brake are connected to the housing of the front axle.

The drive shaft is flange-mounted to the brake drum 1.

The drum brake has an automatic adjuster 11.

The retaining springs 8 hold the brake shoes in position.

#### 2 Function

##### 2.1 Basic function

The drum brake has two functions:

- Service brake
- Parking brake

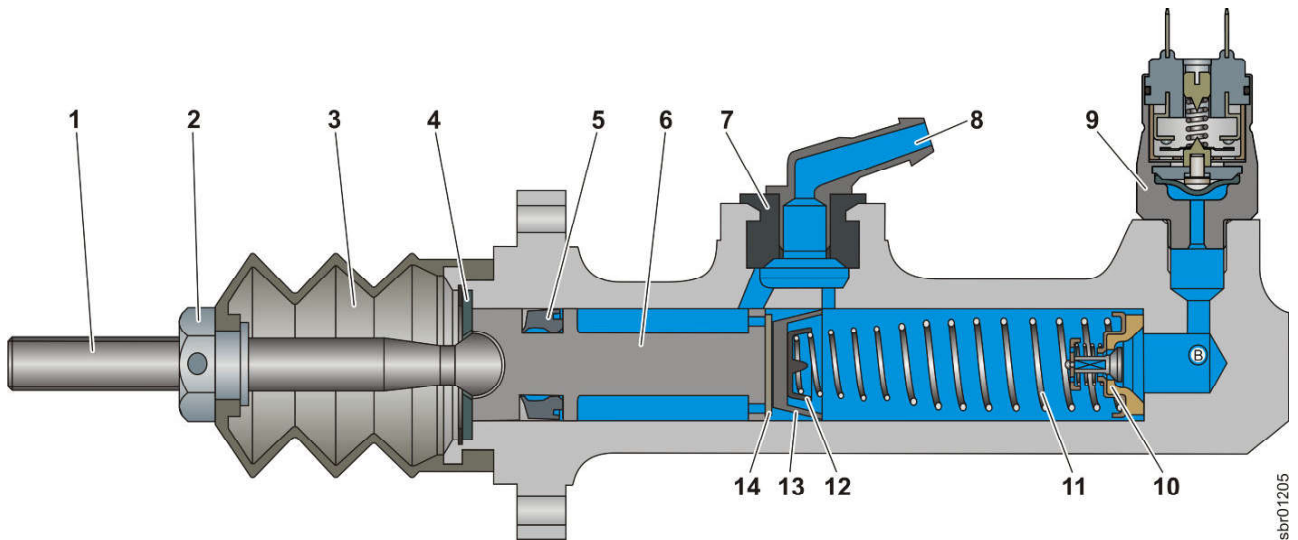

Fig. 344: Sectional view of brake master cylinder (inactive)

- |                  |                                   |                   |
|------------------|-----------------------------------|-------------------|
| 1 Push rod       | 6 Brake piston                    | 11 Return spring  |
| 2 Nut            | 7 Equalizing reservoir connection | 12 Spring cup     |
| 3 Bellows        | 8 Adapter                         | 13 Primary gasket |
| 4 Shim           | 9 Brake light pressure switch B12 | 14 Filler disc    |
| 5 Secondary seal | 10 Floor valve                    |                   |

## 2 Function

### 2.1 Basic function

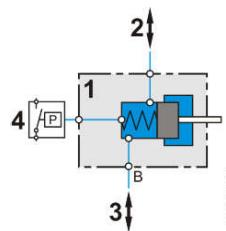

Fig. 345: Hydraulic diagram of brake master cylinder

- |                         |                                   |
|-------------------------|-----------------------------------|
| 1 Brake master cylinder | 3 Drum brake                      |
| 2 Equalising reservoir  | 4 Brake light pressure switch B12 |

The inching-brake pedal together with the inching valve actuate the push rod on the brake master cylinder 1.

The brake master cylinder converts the pressure of the inching-brake pedal into hydraulic pressure. The brake linings are pressed against the brake drum in the drum brake 3 with this hydraulic pressure.

The pressure also actuates the brake light pressure switch 4.

LBH1182765/07211+20190529\_073924/en

BMK	Function	BMK	Function
B12	Brake light pressure switch	Mp4	Earthing point
B15	Bucket return-to-dig inductive switch	Mp6	Earthing point
B16	Back-up alarm	Mp7	Earthing point
B25	Fuel level sensor	X44	Diagnostic plug for engine
B27	Air conditioning pressure switch	X60	Diagnostic plug
F07a	Hazard warning system fuse	Y2	Forward travel direction solenoid valve
F200	Engine control unit fuse	Y3	Reverse travel direction solenoid valve
F201	Exhaust gas recirculation fuse	Y6	Travel range 1 solenoid valve
F202	Engine start fuse	Y13	Fan motor proportional valve
G2	Battery	Y14	Working hydraulics lockout solenoid valve
H40	Buzzer	Y22	Air conditioning compressor magnetic coupling (optional)
K62	Starter relay	Y53	Quick coupler solenoid valve (optional)
K63	Preglow relay		

Tab. 61: Component designations

BMK	SYSTEM	PLACE	FUNCTION	SHEET
-A1	=K	+K1	DISPLAY	/23.B1
-A1.X1	=K	+K1	PLUG DISPLAY	/23.B1
-A3	=K	+K3	RADIO	/31.D6
-A3.X1	=K	+K3	PLUG RADIO	/31.D6
-A3.X2	=K	+K3	PLUG RADIO	/31.E6
-A4.X40	=K	+K4	PLUG RELAY BOARD	/12.B2
-A4.X41	=K	+K4	PLUG RELAY BOARD	/15.D2
-A4.X42	=K	+K4	PLUG RELAY BOARD	/18.B5
-A4.X42/5 *	=K	+K4	MIRROR HEATING	/41.B2
-A4.X43	=K	+K4	PLUG RELAY BOARD	/28.C4
-A4.X44	=K	+K	PLUG RELAY BOARD	/12.B5
-A4.X45	=K	+K4	PLUG RELAY BOARD	/25.D2
-A4.X46	=K	+K	PLUG RELAY BOARD	/21.C5
-A4.X47	=K	+K4	PLUG RELAY BOARD	/27.E2
-A4.X49	=K	+K4	PLUG RELAY BOARD	/18.D7
-A4.X50	=K	+K4	PLUG RELAY BOARD	/27.E3
-A4.X51	=K	+K4	PLUG RELAY BOARD	/27.E1
-A4.X52	=K	+K4	PLUG RELAY BOARD	/27.C7
-A4.X53	=K	+K4	PLUG RELAY BOARD	/15.D7
-A6.A	=K	+K2	UEC 3 X3	/35.B1
-A6.A.X3	=K	+K2	PLUG UEC3 X3	/14.B4
-A6.B	=K	+K4	UEC3 X4	/36.B1
-A6.B.X4	=K	+K4	PLUG UEC3 X4	/15.B2
-A9 *	=K	+K2	IMMOBILISER	/51.C2
-A9.X *	=K	+K2	PLUG IMMOBILISER	/51.C2
-A10	=K	+K1	DISPLAY	/32.B1
-A10.X1	=K	+K1	PLUG ROAD DISPLAY	/23.B7
-A10.X2	=K	+K1	PLUG ROAD DISPLAY	/23.B4
-A700	=M	+M	ENGINE ECU 94 POL.	/61.A1
-A700.1	=M	+M	ENGINE ECU 60 POL.	/62.A1
-A700.1.X	=M	+M	PLUG ENGINE ECU 60 POL.	/68.E6
-A700.X	=M	+M	PLUG ENGINE ECU 94 POL.	/63.E2
-B1	=H	+H4	ENGINE SPEED SENSOR OUTPUT	/16.D6
-B1.X	=H	+H4	PLUG OUTPUT	/16.D6
-B4	=H	+H3	VACUUM SWITCH AIR FILTER CONTAMINATION	/24.E3
-B4.X	=H	+H3	PLUG AIR FILTER CONTAMINATION	/24.E3

BMK	SYSTEM	PLACE	FUNCTION	SHEET
-B5	=H	+H	PRESSURE SWITCH PARKING BRAKE	/26.D4
-B5.X	=H	+H	PLUG PRESSURE SWITCH PARKING BRAKE	/26.D4
-B5a	=K	+K	SWITCH PARKING BRAKE	/26.D5
-B5a.X2	=K	+K	PLUG PARKING BRAKE	/26.D5
-B5a.X3	=K	+K	PLUG PARKING BRAKE	/26.D5
-B8	=H	+H4	TEMPERATURE HYDRAULICS OIL	/24.E5
-B8.X	=H	+H4	PLUG TEMPERATURE HYDRAULICS OIL	/24.E5
-B10	=H	+H2	HORN	/29.B2
-B10.X1	=H	+H2	PLUG HORN	/29.B2
-B10.X2	=H	+H2	PLUG HORN	/29.B2
-B11	=K	+K3	LOUDSPEAKER LEFT	/31.F6
-B11.X1	=K	+K3	PLUG LOUDSPEAKER LEFT	/31.E6
-B11.X2	=K	+K3	PLUG LOUDSPEAKER LEFT	/31.F6
-B11r	=K	+K3	LOUDSPEAKER RIGHT	/31.E7
-B11r.X1	=K	+K3	PLUG LOUDSPEAKER RIGHT	/31.E7
-B11r.X2	=K	+K3	PLUG LOUDSPEAKER RIGHT	/31.F7
-B12	=V	+V1	PRESSURE SWITCH STOP LIGHT	/28.E3
-B12.X1	=V	+V1	PLUG PRESSURE SWITCH STOP LIGHT	/28.E3
-B12.X2	=V	+V1	PLUG PRESSURE SWITCH STOP LIGHT	/28.E3
-B15 *	=V	+V3	INDUCTIVE SWITCH BUCKET RETURN-TO-DIG	/21.D8
-B15.X	=V	+V3	PLUG INDUCTIVE SWITCH	/21.D8
-B16	=H	+H5	BACK-UP ALARM	/18.D8
-B16.X	=H	+H5	PLUG BACK-UP ALARM	/18.D8
-B17 *	=V	+V2	INDUCTIVE SWITCH LIFT KICK-OUT	/42.D4
-B17.X *	=V	+V2	PLUG SENSOR LIFT KICK-OUT	/42.D4
-B25	=H	+H2	TANK PIPE SENSOR	/16.E2
-B25.X	=H	+H2	PLUG TANK PIPE SENSOR	/16.E2
-B26	=K	+K	TEMPERATURE SWITCH AIR CONDITIONING SYSTEM	/25.D4
-B26.X30b	=K	+K	PLUG TEMPERATURE SWITCH AIR CONDITIONING SYSTEM	/25.D4
-B27 *	=H	+H	PRESSURE SWITCH AIR CONDITIONING SYSTEM	/25.B4
-B27.X *	=H	+H	PLUG PRESSURE SWITCH AIR CONDITIONING SYSTEM	/25.B4
-E1	=B	+B1	REVERSING LAMP LEFT	/28.E3
-E1.X1	=B	+B1	PLUG REVERSING LAMP LEFT	/28.E3
-E1.X2	=B	+B1	PLUG REVERSING LAMP LEFT	/28.E3
-E1.X3	=B	+B1	PLUG REVERSING LAMP LEFT	/28.E3
-E1.X4	=B	+B1	PLUG REVERSING LAMP LEFT	/28.E3

# DIAGNOSTIC PLUG

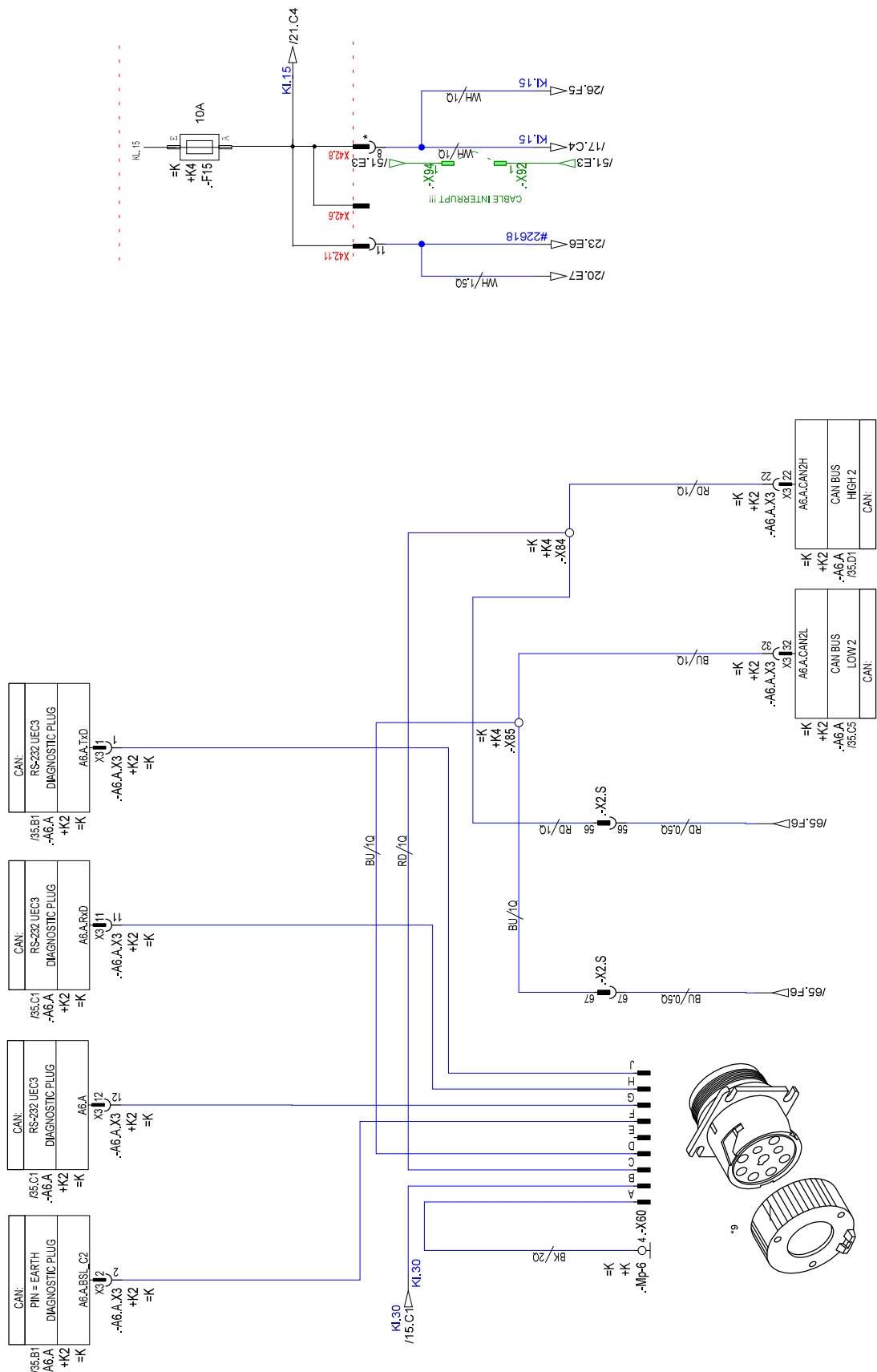

REPLACEMENT FOR DRAWN 0	Hotter A.	<b>LIEBHERR</b> FACTORY	<b>A3</b>	DESIGNATION E-SCHEMA	DESCRIPTION DIAGNOSTIC PLUG	ARTICLE CODE	SYSTEM	PLACE
	DATE 24.05.2019 09:30					93020880		
CONFIDENTIAL	INSPECTED					DRAWING NUMBER	INDEX	SHEET 14
	TECHNICAL REFEREE					1259 00090 01 00	004	FROM 73
						ARTICLE CODE 000888	VERSION	24.05.2019 09:30

PRESSURE SWITCH AIR FILTER

HYDRAULIC OIL TEMPERATURE , FAN ,

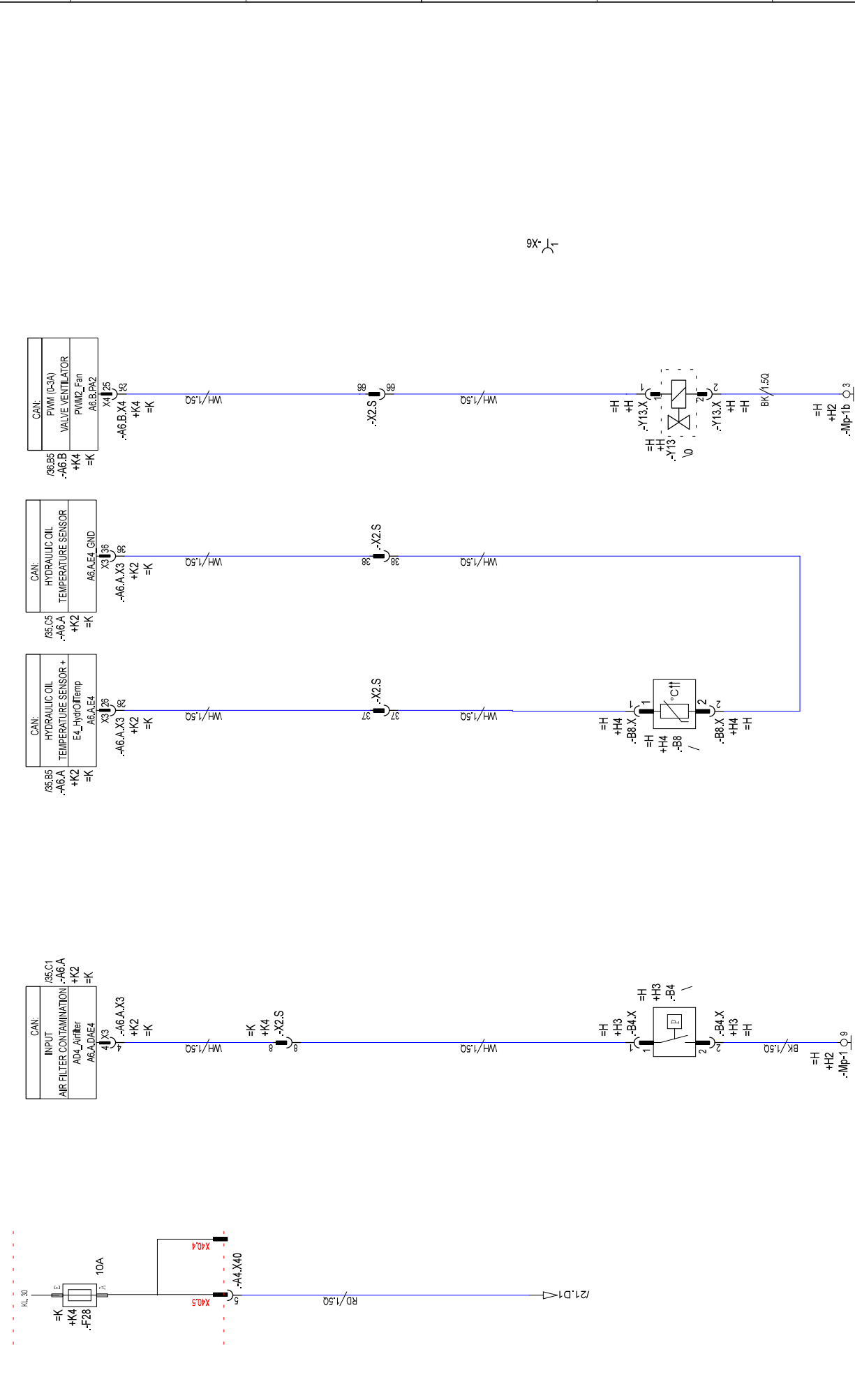

REPLACEMENT FOR	DATE	DESCRIPTION	ARTICLE CODE	SYSTEM	PLACE
0	24.05.2019 09:30	PRESSURE SWITCH AIR FILTER	S3020880		
CONFIDENTIAL	INSPECTED	E-SCHEMA	1259 00090 01 00	SHEET 24	FROM 73
	TECHNICAL REFEREE			ARTICLE CODE 000888	VERSION 24.05.2019 09:30

**LIEBHERR**  
FACTORY

**A3**

DESIGNATION  
E-SCHEMA

DESCRIPTION  
PRESSURE SWITCH AIR FILTER

ARTICLE CODE  
S3020880

SYSTEM

PLACE

SHEET 24

FROM 73

INDEX

004

VERSION

24.05.2019 09:30



TYPE SPL

# MANUAL INCHING FACILITY

CAN: INPUT		CAN: INPUT		CAN: PNM (3SA)	
85 C1	-AG A	85 D1	-AG A	85 C1	PNM (3SA)
+K2	ED_InchSensor1	+K2	INCHANGLE SENSOR	+K4	INCH-SWIMMELANGLE
=K	AG.A.E0	=K	E1_InchSensor2	=K	AG.B.PA0
	X3U8		AG.A.E1		X4U5
	-AG.A.X3		-AG.A.X3		-AG.B.X4
	+K2		+K2		+K4
	=K		=K		=K

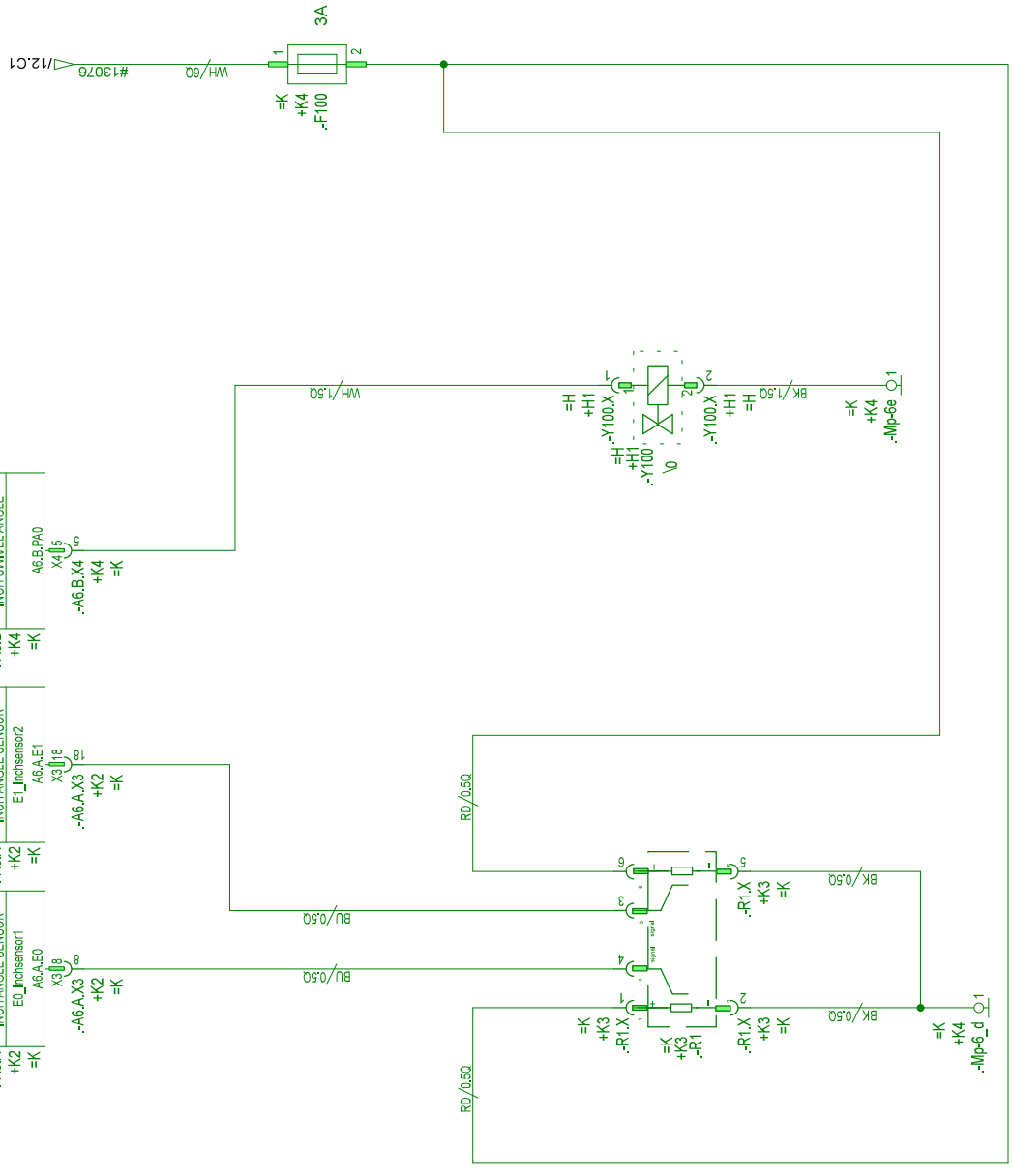

REPLACEMENT FOR DRAWN	DATE	24.05.2019 09:30	<b>LIEBHERR</b>		<b>A3</b>		DESIGNATION		E-SCHEMA		DESCRIPTION		OPTIONAL MANUAL INCHING FACILITY		SYSTEM		PLACE		
0	INSPECTED						FACTORY				ARTICLE CODE		S3020880		INDEX		SHEET 44 FROM 73		
CONFIDENTIAL	TECHNICAL REFEREE										DRAWING NUMBER		1259 00090 01 00		INDEX		ARTICLE CODE 0020880 VERBODEN		
1	2	3	4	5	6	7	8	9	10	11	12	13	14	15	16	17	18	19	20

ISO 15076: The reproduction, distribution and utilization of this document as well as the communication of its contents to others without express authorization is prohibited. Offenders will be held liable for the payment of damages. All rights reserved in the event of the grant of a patent, utility model or design.

TYPE SPL

# MIRROR HEATING

PROJECT: Stereo Stufe 3B

ISO 15076: The reproduction, distribution and utilization of this document as well as the communication of its contents to others without express authorization is prohibited. Offenders will be held liable for the payment of damages. All rights reserved in the event of the grant of a patent, utility model or design.

REPLACEMENT FOR DRAWN DATE 24.05.2019 09:30

CONFIDENTIAL INSPECTED TECHNICAL REFEREE

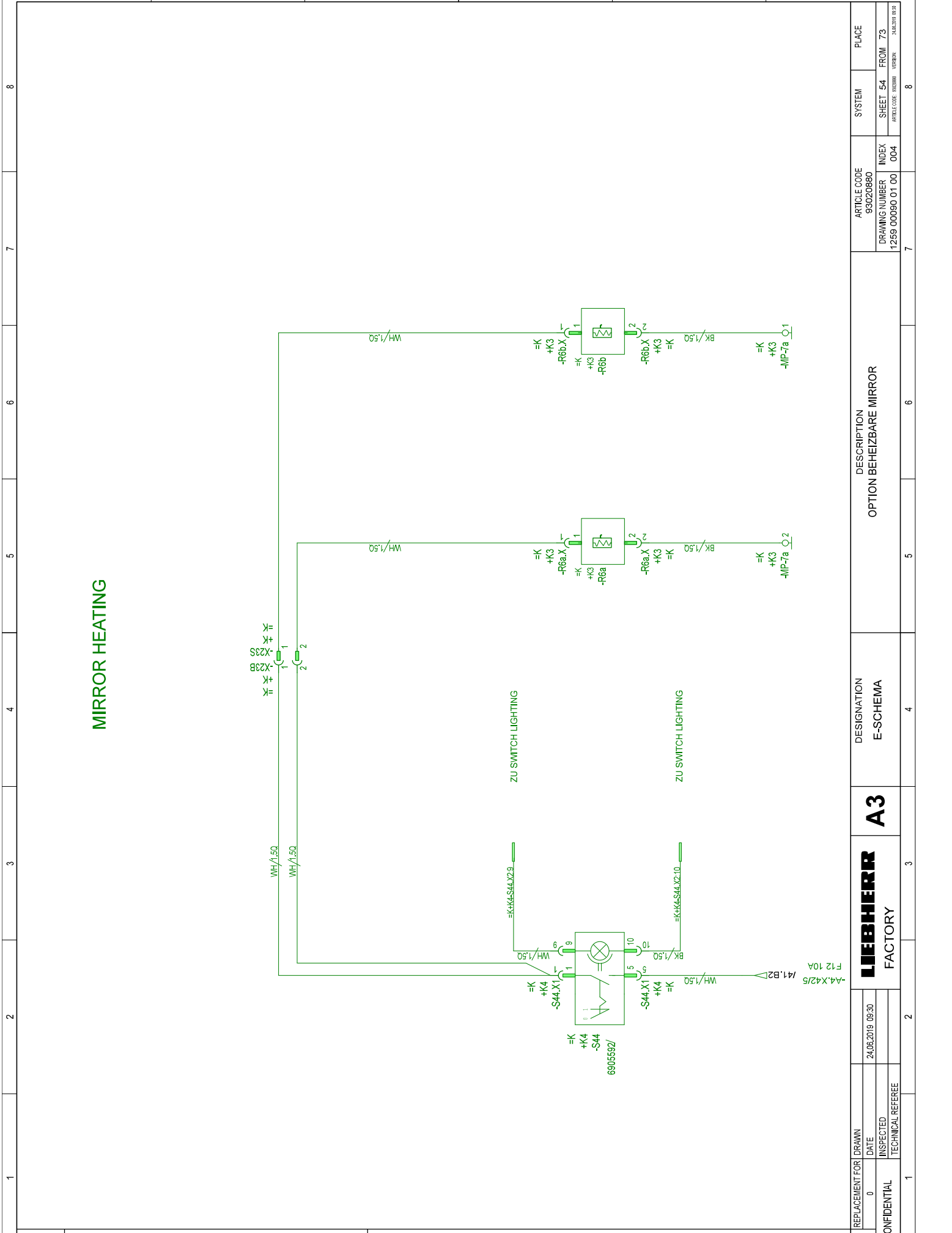

DESCRIPTION  
OPTION BEHEIZBARE MIRROR

ARTICLE CODE  
S3020880

DRAWING NUMBER  
1259 00090 01 00

INDEX  
004

SYSTEM  
SHEET 54

PLACE  
FROM 73

VERSION  
DATE 01.09.2019

1	2	3	4	5	6	7	8
---	---	---	---	---	---	---	---





Fuse	Amps	Component	Fuse	Amps	Component
F1	5 A	Quick coupler	F23	15 A	Central control unit (power supply 2)
F2	7.5 A	Left high beam	F24	15 A	Central control unit (power supply 4)
F3	7.5 A	Right high beam	F25	10 A	Flashing beacon
F4	7.5 A	Right low beam	F26	15 A	Diagnostic plug Central control unit (power supply 1)
F5	7.5 A	Left low beam	F27	10 A	Low beam
F6	3 A	Right marker lights	F28	10 A	Working hydraulics lockout
F7	3 A	Left marker lights	F29	20 A	Ignition switch release
F8	15 A	Radio, socket, compressor seat	F30	10 A	Radio terminal 30
F9	10 A	Parking brake, options	F31	15 A	Front working headlights
F10	5 A	100% differential lockout	F32	15 A	Rear working headlights, interior lighting
F11	10 A	Fuel pre-delivery pump	F33	10 A	Central lubrication system option
F12	10 A	Fan reversal option	F34	10 A	Terminal 15 signal (UEC3)
F13	10 A	Rear accessory kit, regulated flow rate (optional)	F35	10 A	Diesel particulate filter
F14	15 A	Sweeper option	F36		Spare
F15	10 A	Excitation, brake light, operation	F37		Spare
F15A	10A	Engine stop, fuel pipe sensor	F38	10 A	High Flow option
F16	20 A	Starter solenoid	F39		Spare
F17		Spare	F40		Spare
F18	10 A	Rear windscreen wiper motor	F41		Spare
F19	20 A	Heater, air conditioning	Test		Fuse test position
F20	15 A	Front windscreen wiper motor	Test 1		Fuse test with button
F21	15 A	Parking light	Test 2		Fuse test with header
F22	15 A	Central control unit (power supply 3)			

Tab. 74: Fuses

Relay	Component	Relay	Component
K01	Ignition switch release (terminal 15 relay)	K20	Spare
K1	Indicator sensor	K21	Spare
K02	Starter	K22	Hazard warning system
K03	Spare	K23	Spare
K3	Reversing alarm (optional)	K24	Spare
K4	Engine stop	K25	Hazard warning system USA
K5	D+ function	K26	Hazard warning system USA
K6	Spare	K240	Spare
K7	Spare	K241	Spare
K17	Float position	K242	Spare

LBH1182765/07/21+20190529\_073924/en

# 140 Steel parts of the basic machine

## Contents

140.1	Vehicle frame	140-2
140.1.1	Articulation bearing <i>L507-1259/34508-;</i>	140-2
140.1.2	Articulation lock <i>L507-1259/34508-;</i>	140-3

## 160.1 Overview of the cab, heating and air conditioning unit

Valid for: L507-1259/34508-;

### 1 Layout

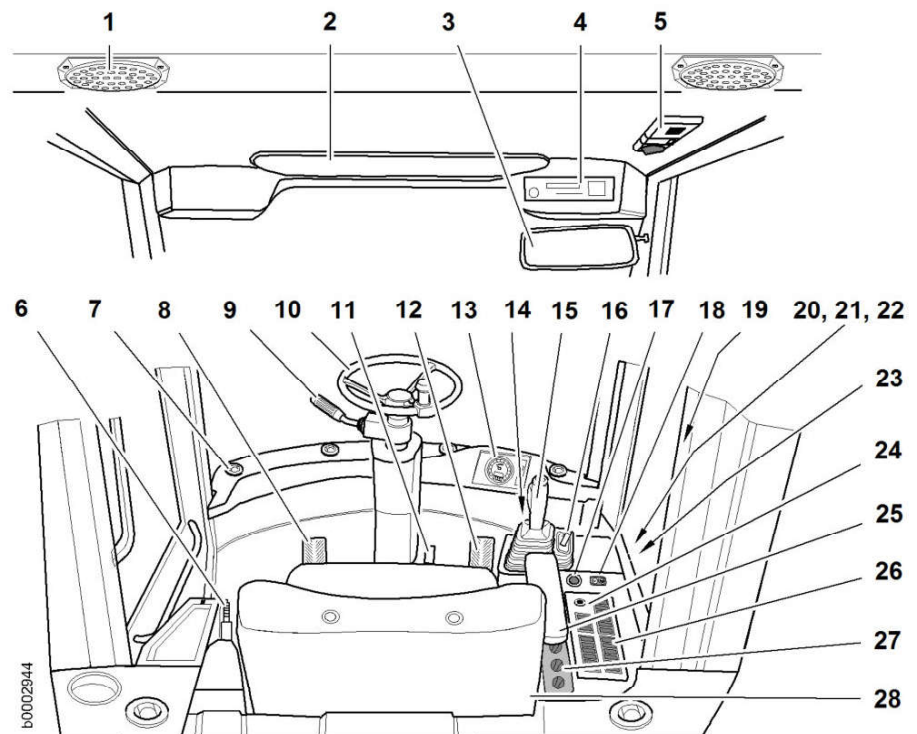

Fig. 374: Operator's cab

- |    |   |    |  |
|----|---|----|--|
| 1  | Radio speaker   | 15 | Control lever                                    |
| 2  | Sun visor   | 16 | Additional control lever (optional)              |
| 3  | Interior mirror   | 17 | Cigarette lighter socket X71                     |
| 4  | Radio installation  | 18 | Diesel particulate filter switch/<br>button S700 |
| 5  | Interior lighting   | 19 | Fire extinguisher (optional)                     |
| 6  | Parking brake   | 20 | Fuse box   |
| 7  | Outlet nozzles, heater/<br>ventilation/air conditioning<br>(optional) | 21 | Control electronics                              |
| 8  | Inch/brake pedal  | 22 | Control relay                                    |
| 9  | Steering column switch S3   | 23 | Diagnostic plug X60                              |
| 10 | Steering wheel  | 24 | Starter switch S1                                |
| 11 | Steering wheel adjustment lever                                       | 25 | Adjustable arm rest                              |
| 12 | Accelerator pedal R5  | 26 | Switch panel                                     |
| 13 | Display A10   | 27 | Heater/ventilation switch                        |
| 14 | Operating manual compartment  | 28 | Driver's seat                                    |

The driver's cab is mounted on a flexible bearing on the rear section.



## 2 Function

The blower is a 3-speed radial fan for ventilation, heating and air conditioning in the driver's cab.

The fan draws the air through the axial air intake **4** and blows it through the radial air outlet **5** to the heat exchanger of the heater. If an air conditioning unit is installed, air is first supplied to the evaporator.

The air flow is regulated by changing the blower speed.

The unit is operated and controlled using the *blower motor* knob. On level 0, the blower is switched off. Level 3 is for maximum air flow.

# 170 Lubrication system

## Contents

170.1	Liebherr automatic central lubrication system	170-2
170.1.1	Automatic central lubrication system: General overview <i>L507-1259/34508-;</i>	170-2
170.1.2	Central lubrication pump EP-1 <i>L507-1259/34508-;</i>	170-6
170.1.3	Progressive distributor MX-F <i>L507-1259/34508-;</i>	170-9

After the piston **III** is moved, the lubricant flows to the left side of the piston **I** (piston position **C**). The piston **I** moves to the right and presses the lubricant out of the right pressure chamber of the piston to outlet **4**.

Then the pistons **II** and **III** pump the lubricant to the outlets **5** and **6**.

After the piston **III** moves, the lubricant flows back to the right side of the piston **I** (piston position **A**) and a new cycle of the progressive distributor starts. This function is repeated for as long as lubricant is pumped to the progressive distributor.

### 2.1.1 Effects of malfunctions

Malfunctions can occur in the network of lubrication lines or in the distributor.

Malfunctions include:

- Blocked lubrication lines
- Twisted split bushings

These malfunctions interrupt the flow of lubricant. This blocks the distributor.

When the distributor is blocked, lubricant escapes via the pressure relief valve of the central lubrication pump.

CLICK HERE TO **DOWNLOAD** THE COMPLETE MANUAL

- Thank you very much for reading the preview of the manual.
- You can download the complete manual from: [www.heydownloads.com](http://www.heydownloads.com) by clicking the link below



- Please note: If there is no response to CLICKING the link, please download this PDF first and then click on it.

CLICK HERE TO **DOWNLOAD** THE COMPLETE MANUAL