

en

Service manual

Wheel loader

Document ID

Order number: 12278872
Issued: 2022-02-10
Version: 00
Author: LBH / Technical Documentation Department

Product ID

Manufacturer: Liebherr-Werk Bischofshofen GmbH
Valid for: L 504-1851

Contact

Liebherr-Werk Bischofshofen GmbH
Dr. Hans Liebherr-Straße 4
A – 5500 Bischofshofen

CLICK HERE TO **DOWNLOAD** THE COMPLETE MANUAL

- Thank you very much for reading the preview of the manual.
- You can download the complete manual from: www.heydownloads.com by clicking the link below



- Please note: If there is no response to CLICKING the link, please download this PDF first and then click on it.

CLICK HERE TO **DOWNLOAD** THE COMPLETE MANUAL

| | | |
|------------|--|--------|
| 030.4.4.1 | Checking diesel engine oil level <i>L504-1851;</i> | 030-49 |
| 030.4.4.2 | Diesel engine: changing the diesel engine oil <i>L504-1851;</i> | 030-51 |
| 030.4.4.3 | Diesel engine: changing oil filter <i>L504-1851;</i> | 030-53 |
| 030.4.4.4 | Diesel engine: checking V-belt <i>L504-1851;</i> | 030-55 |
| 030.4.4.5 | Diesel engine: changing V-belt <i>L504-1851;</i> | 030-57 |
| 030.4.4.6 | Diesel engine: checking valve clearance <i>L504-1851;</i> | 030-58 |
| 030.4.4.7 | Fuel tank: draining condensate and sediment <i>L504-1851;</i> | 030-63 |
| 030.4.4.8 | Fuel pre-filter: draining off condensate <i>L504-1851;</i> | 030-63 |
| 030.4.4.9 | Changing fuel pre-filter element <i>L504-1851;</i> | 030-64 |
| 030.4.4.10 | Fuel fine filter: changing the filter element <i>L504-1851;</i> | 030-66 |
| 030.4.4.11 | Air filter system: cleaning service cover and dust discharge valve <i>L504-1851;</i> | 030-67 |
| 030.4.4.12 | Checking air filter vacuum switch function <i>L504-1851;</i> | 030-68 |
| 030.4.4.13 | Cleaning or changing the main element of the air filter system <i>L504-1851;</i> | 030-70 |
| 030.4.4.14 | Lufffilteranlage: Sicherheitselement wechseln <i>L504-1851;</i> | 030-72 |
| 030.4.4.15 | Checking that diesel engine intake and exhaust system is in good condition and not loose or leaking <i>L504-1851;</i> | 030-73 |
| 030.4.4.16 | Diesel particulate filter: cleaning or changing filter module <i>L504-1851;</i> | 030-75 |
| 030.4.5 | Cooling system | 030-77 |
| 030.4.5.1 | Cooling system: checking coolant level <i>L504-1851;</i> | 030-77 |
| 030.4.5.2 | Coolant: checking anti-freeze and corrosion protection agent concentration <i>L504-1851;</i> | 030-79 |
| 030.4.5.2 | Checking the corrosion inhibitor concentration <i>L504-1851;</i> | 030-79 |
| 030.4.5.3 | Cleaning the cooling system <i>L504-1851;</i> | 030-86 |

| Symbol | Meaning |
|--------|---|
| — | List Identifies individual items of a list. |

Tab. 3: Symbols

010.1.2 Intended use

010.1.2.1 Laws, rules, guidelines and safety regulations

To ensure safe operation:

- Ask work site manager for safety regulations at place of use.
- Adhere to safety regulations at place of use.
- Adhere to traffic regulations.
- Adhere to valid guidelines from insurers (for example employers' professional liability insurance companies, accident insurance et cetera).
- Avoid working methods that can endanger safety.
- Adhere to all intervals specified for recurrent checks and inspections in this operator's manual.

010.1.2.2 Intended use

Wheel loader is used to pick up, move and dump following materials:

- Soil
- Stones
- Broken rocks
- Bulk materials

This applies to a standard machine in normal operating conditions. Special applications are described in a separate options operator's manual.

To ensure intended use:

- Adhere to operator's manual.
- Adhere to maintenance intervals.
- Observe inspection and maintenance tasks.
- Adhere to specifications in the technical data.
- When using machine on public roads, make sure it complies with applicable national regulations.
- Only lift loads with intended working attachments (fork prongs, crane boom), which must be fitted and functioning.
- Make sure that machines used underground (mining and tunnel construction) are fitted with systems to reduce exhaust emissions (such as diesel particulate filters).
- Adhere to individual country's requirements for underground operation.
- For special uses use special working attachments and if necessary special safety equipment.
- Exclusively mount and use special working attachments with approval and as per stipulations of manufacturer of basic machine.
- Only use approved tyres.
- A suitably equipped workshop is absolutely essential for performing repair work.



Note

- ▶ Any other use or use beyond the stated use is improper use.

Incorrect equipment

- Make sure that emergency hammer (option) is present.
- Make sure that position of emergency hammer (option) is known.

010.1.5.2 Fire extinguisher (option)**Danger to life****Incorrect behaviour**

- Make sure that all fastening points of fire extinguishers on the machine are known.
- Make sure that everyone is able to operate the fire extinguishers.
- Make sure that everyone knows local fire alarm options.
- Make sure that everyone knows the local fire-fighting possibilities.
- Before starting machine, unlock all locks of hoods and doors of machine.

010.1.6 Safe operation**010.1.6.1 Intoxicants****Danger to life****Physical and mental impairment**

- Make sure that no persons working on or with the machine are under the influence of drugs.
- Make sure that no persons working on or with the machine are under the influence of alcohol.
- Make sure that no persons working on or with the machine are under the influence of medication.
- Make sure that no persons working on or with the machine are overtired.
- Make sure that no persons working on or with the machine are exhausted.

010.1.6.2 Dangerous fuels and operating fluids**Injury****Incorrect handling**

- Adhere to safety instructions on handling oils, greases and chemical substances.
- In case of hot lubricants and fuels put on personal protective equipment.

Environmental damage**Incorrect disposal**

- Dispose of lubricants and fuels safely and in eco-friendly manner.
- Adhere to guidelines applicable to disposal.

| Designation | Item code | Remark | Fig. |
|--|-----------|---|--|
| Yanmar SMARTASSIST diagnostic software | | For diesel engine diagnosis. For more information see Service Information LBH - 04-15-09/14 |  92087594 |

Tab. 4: Special tools for diesel engine

010.2.2 Special tools for lift cylinders

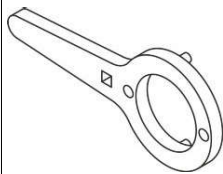
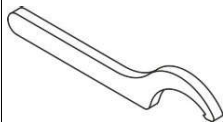
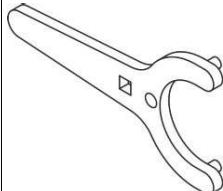
| Designation | Item code | Remark | Fig. |
|--|-----------|---------------------------------|--|
| Piston wrench 75/12 mm | 8007364 | For piston assembly |  |
| Piston nut wrench 68/75 mm (hook wrench) | 885171501 | For piston nut assembly |  |
| Piston rod bearing wrench 92/8 mm | 0541063 | For piston rod bearing assembly |  |

Tab. 5: Special tools for lift cylinders

010.2.3 Special tools for tilt cylinders

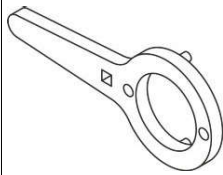
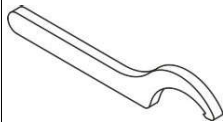
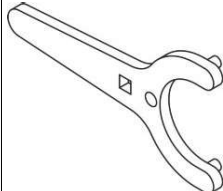
| Designation | Item code | Remark | Fig. |
|---|-----------|---------------------------------|---|
| Piston wrench 60/10 mm | 9131362 | For piston assembly |  |
| Spanner for piston nut (hook wrench DIN 1810) | 7900282 | For piston nut assembly |  |
| Piston rod bearing wrench ??? mm | ??? | For piston rod bearing assembly |  |

Tab. 6: Special tools for tilt cylinders

| Metric standard threads and fine threads | | | | Metric standard threads and fine threads | | | |
|---|----------------|--|--------------------------------|--|----------------|--|--------------------------------|
| At least one element of the bolted joint (bolts, washers, nuts etc.) with the following surface: fIZn = zinc flake coating (LH standard 10021432, LH standard 10215295 fIZnnc-480h-L valid \geq M6) | | | | All elements of the bolted joint (bolts, washers, nuts etc.) with the following surface: Black oxide or phosphated Galvanised (LH standard 10215295 Fe//ZnNi(12)5//Cn//T2) | | | |
| Minimum total coefficient of friction $\mu_G = 0.09$ | | | | Minimum total coefficient of friction $\mu_G = 0.11$ | | | |
| Thread | Strength class | Assembly prestressing forces F_M in kN | Tightening torques M_A in Nm | Thread | Strength class | Assembly prestressing forces F_M in kN | Tightening torques M_A in Nm |
| M 22 x 1.5 | 8.8 | 180 | 480 | M 22 x 1.5 | 8.8 | 180 | 570 |
| | 10.9 | 270 | 700 | | 10.9 | 260 | 830 |
| | 12.9 | 310 | 820 | | 12.9 | 310 | 970 |
| M 24 | 8.8 | 190 | 570 | M 24 | 8.8 | 185 | 660 |
| | 10.9 | 280 | 840 | | 10.9 | 270 | 970 |
| | 12.9 | 320 | 980 | | 12.9 | 320 | 1140 |
| M 24 x 1.5 | 8.8 | 220 | 620 | M 24 x 1.5 | 8.8 | 215 | 730 |
| | 10.9 | 320 | 910 | | 10.9 | 320 | 1080 |
| | 12.9 | 380 | 1070 | | 12.9 | 370 | 1250 |
| M 24 x 2 | 8.8 | 210 | 600 | M 24 x 2 | 8.8 | 205 | 710 |
| | 10.9 | 310 | 890 | | 10.9 | 300 | 1040 |
| | 12.9 | 360 | 1040 | | 12.9 | 350 | 1220 |
| M 27 | 8.8 | 245 | 830 | M 27 | 8.8 | 240 | 970 |
| | 10.9 | 360 | 1230 | | 10.9 | 360 | 1450 |
| | 12.9 | 420 | 1450 | | 12.9 | 420 | 1650 |
| M 27 x 1.5 | 8.8 | 280 | 900 | M 27 x 1.5 | 8.8 | 280 | 1060 |
| | 10.9 | 410 | 1300 | | 10.9 | 410 | 1550 |
| | 12.9 | 480 | 1550 | | 12.9 | 480 | 1850 |
| M 27 x 2 | 8.8 | 270 | 880 | M 27 x 2 | 8.8 | 260 | 1030 |
| | 10.9 | 400 | 1300 | | 10.9 | 390 | 1500 |
| | 12.9 | 460 | 1500 | | 12.9 | 460 | 1800 |
| M 30 | 8.8 | 300 | 1140 | M 30 | 8.8 | 290 | 1300 |
| | 10.9 | 440 | 1650 | | 10.9 | 430 | 1950 |
| | 12.9 | 520 | 1950 | | 12.9 | 510 | 2250 |
| M 30 x 1.5 | 8.8 | 350 | 1240 | M 30 x 1.5 | 8.8 | 350 | 1450 |
| | 10.9 | 520 | 1800 | | 10.9 | 510 | 2150 |
| | 12.9 | 610 | 2150 | | 12.9 | 590 | 2500 |
| M 30 x 2 | 8.8 | 340 | 1220 | M 30 x 2 | 8.8 | 330 | 1450 |
| | 10.9 | 500 | 1800 | | 10.9 | 490 | 2100 |
| | 12.9 | 580 | 2100 | | 12.9 | 570 | 2450 |

LBH/1227867/00/211-20220210_134616/en

020.1 Overall machine

020.1.1 Complete machine with loading bucket

Valid for: L504-1851;

Values stated refer to machine:

- In its standard version
- With 340/80R18 tyres
- Including all lubricants
- With a full fuel tank
- With ROPS/FOPS cab and operator
- On level and stable ground



Note

Tyres and working attachment affect operating mass and tipping load.

► Note information about tyres and working attachment.

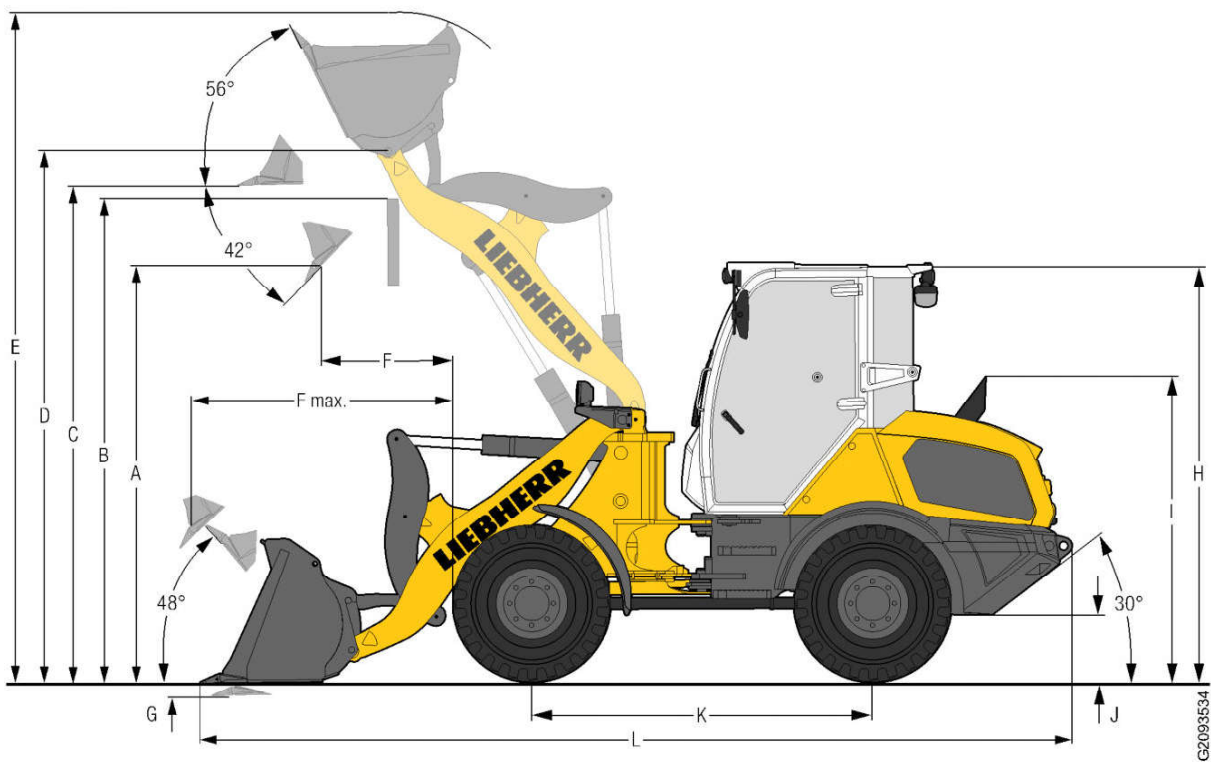

Fig. 26

| Designation | Unit | Value |
|-----------------|------|-------|
| Load geometry | | A) |
| Cutting tool | | B) |
| Lift arm length | mm | 2200 |

LBH/1227867/00/211-20220210_134616/en

G2093534

| Description | Unit | Value |
|---|------|-------|
| Stroke length | mm | 430 |
| Weight | kg | 34.8 |
| Tightening torque of piston rod bearing | Nm | 700 |
| Tightening torque of piston | Nm | 350 |
| Tightening torque of piston nut | Nm | 100 |

030 Maintenance

Contents

| | | |
|-----------|---|--------|
| 030.1 | Maintenance and inspection schedule | 030-7 |
| 030.2 | Filling quantities and lubrication chart | 030-12 |
| 030.2.1 | Lubricant filling quantity <i>L504-1851;</i> | 030-12 |
| 030.2.2 | Fuel and operating fluid filling quantity <i>L504-1851;</i> | 030-12 |
| 030.3 | Lubricants and fuels | 030-13 |
| 030.3.1 | General information on lubricants and fuels | 030-13 |
| 030.3.1.1 | General questions | 030-13 |
| 030.3.1.2 | Safety data sheets | 030-13 |
| 030.3.1.3 | Technical data sheets | 030-13 |
| 030.3.1.4 | Specific Liebherr standards | 030-13 |
| 030.3.2 | General information on changing lubricants and fuels | 030-13 |
| 030.3.3 | Converting hydraulic system from mineral oils to biodegradable hydraulic fluids | 030-14 |
| 030.3.4 | Diesel fuels <i>L504-1851;</i> | 030-14 |
| 030.3.5 | Engine oils <i>L504-1851;</i> | 030-15 |
| 030.3.6 | Refrigerant <i>L504-1851;</i> | 030-16 |
| 030.3.7 | Coolant <i>L504-1851;</i> | 030-16 |
| 030.3.8 | Hydraulic oil <i>L504-1851;</i> | 030-17 |
| 030.3.9 | Transmission <i>L504-1851;</i> | 030-18 |
| 030.3.10 | Axle oil <i>L504-1851;</i> | 030-18 |
| 030.3.11 | Brake oil <i>L504-1851;</i> | 030-19 |
| 030.3.12 | Lubrication grease <i>L504-1851;</i> | 030-19 |

Customer:.....Machine type:.....Serial no.:.....Operating hours:.....Date:.....

| Maintenance / inspection after service hours | | | | | | Tasks to be performed | | | | |
|--|------------|----------|-----------|------------|-----------------|-----------------------|---|--|---------------|----------|
| On handover | All 8-10 h | All 50 h | All 500 h | All 1000 h | All 2000 h | Additional labelling | By maintenance staff ■ Once-only activity ● Repeat interval † If necessary ✱ Annually before the winter | By authorised specialist staff □ Once-only activity ○ Repeat interval ✧ If necessary | Confirm tasks | See page |
| | | | | | Other intervals | | Additional labelling ††† Assistance required † Have this task carried out exclusively by a certified electrician | | | |
| Lubrication system | | | | | | | | | | |
| <input type="checkbox"/> | | ● | ○ | ○ | ○ | | Central lubrication system (option): check level grease reservoir. | | | 030-136 |
| <input type="checkbox"/> | | ● | ○ | ○ | ○ | | Central lubrication system (option): check pipes, hoses and lubrication points for leaks and damage. | | | 030-137 |
| <input type="checkbox"/> | | ● | ○ | ○ | ○ | | Central lubrication system (option): check lubrication of bearings. | | | 030-138 |

LBH/12278872/00/211-20220210_134616/en

030.4 Maintenance tasks

All work must be carried out by **specialist technicians** or under their supervision and responsibility.

Specialists technicians are people who:

- Have the requisite training and experience in operating and servicing earth-moving machinery
- Are familiar with the statutory accident prevention regulations and national guidelines
- Are able to judge whether earthmoving machinery is safe to operate
- Can carry out the required work without endangering themselves or others

030.4.1 Safety precautions

Valid for: L504-1851;

Observe the relevant **safety instructions** when carrying out all maintenance, inspection or repair work. Local health and safety regulations, accident prevention regulations and national laws must be observed.

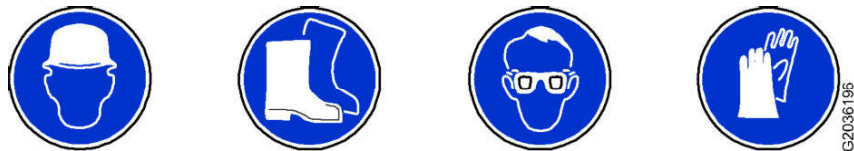

Fig. 32: Safety precautions

Make sure that following requirements are met:

- Suitable protective equipment is present.
- The driver and maintenance staff are in visual contact.

Protective equipment must be worn for some tasks:

- Hard hat
- Safety footwear
- Safety glasses
- Protective gloves



WARNING

Persons in hazard zone!
Injury.

- ▶ Make sure there is nobody in hazard zone.
- ▶ Wear appropriate working clothing.
- ▶ Always maintain visual contact with the maintenance staff.

030.4.2 Preparatory tasks for maintenance

Before performing the various maintenance tasks, move the machine to the maintenance position unless otherwise explicitly specified in the description.

The various maintenance tasks include:

- Lubricating the lift arms and attachment
- Checking the oil level in the engine, transmission, axles, hydraulic tank, etc.

| Components | Fuel and operating fluid | Cover colour | | |
|--------------------|---|------------------|----------|------------------|
| | | Routine analysis | Question | Suspected damage |
| Diesel engine | Engine oil | ● | | ● |
| | Coolant | ● | | ● |
| | Diesel exhaust fluid | | | ● |
| | Diesel fuel | ● | | ● |
| | Check diesel fuel for petrol content. | | ● | |
| | Check diesel fuel for biodiesel content. | | ● | |
| | Check diesel fuel for cold-weather performance. | | ● 17) | |
| Hydraulic system | Mineral oil | ● | | ● |
| | Check mineral oil for solids content. | | ● | |
| | Check mineral oil for exact water content. | | ● 18) | |
| | Bio oil | ● | | ● |
| Transmission | Axle gear oil Differential | ● | | ● |
| | Axle gear oil Wheel heads | | | ● |
| | Transmission oil | ● | | ● |
| | Pump distributor gear oil | ● | | ● |
| | Check gear oil for exact water content. | | ● | |
| | Check gear oils for ageing. | | ● | |
| | Check gear oils for particle origin. | | ● | |
| Lubrication system | Lubrication grease Check grease quality | | | ● |

Tab. 52: Analysis sets



LBH/1227867/00/211-20220210_134616/en

17) **Cloudpoint ermitteln** (= Determine cloud point) specification is required on the sample information form.

18) **Wasser Karl Fischer** (= Water Karl Fischer) specification is required on the sample information form.

Hydraulic system

Mineral oils

| Cover colour | Appearance | Wear | Additives | Contamination | PQ index | Viscosity 40 °C | Viscosity 100 °C | Viscosity index | Particle counting | Oxidation | IR index | Water with IR | Water according to K. F. | Solid foreign matter | Neutralisation number |
|---|---|------|-----------|---------------|----------|-----------------|------------------|-----------------|-------------------|-----------|----------|---------------|--------------------------|----------------------|-----------------------|
| |  | X | X | X | X | X | X | X | X | X | X | X | X | | |
|  | X | X | X | X | X | X | X | X | X | X | X | | | X | |
|  | X | X | X | X | X | X | X | X | X | X | X | | X | X | X |



Tab. 60: Scope of analysis of mineral oils

Bio oils

| Cover colour | Appearance | Wear | Additives | Contamination | PQ index | Viscosity 40 °C | Viscosity 100 °C | Viscosity index | Density | Particle counting | IR index | Water according to K. F. | Neutralisation number |
|---|------------|------|-----------|---------------|----------|-----------------|------------------|-----------------|---------|-------------------|----------|--------------------------|-----------------------|
|  | X | X | X | X | X | X | X | X | X | X | X | X | X |

Tab. 61: Scope of analysis of bio oils

Axles

| Cover colour | Appearance | Wear | Additives | Contamination | PQ index | Viscosity 40 °C | Viscosity 100 °C | Viscosity index | Oxidation | IR index | Water with IR | Water according to K. F. | Neutralisation number | Optical particle counting |
|---|------------|------|-----------|---------------|----------|-----------------|------------------|-----------------|-----------|----------|---------------|--------------------------|-----------------------|---------------------------|
|  | X | X | X | X | X | X | X | X | X | X | X | | | |
|  | X | X | X | X | X | X | X | X | X | X | | X | | |

LBH/12278872/00/211-20220210_134616/en

- ▶ Open the cover 1.

NOTICE

Non-approved oil!
Damage.

- ▶ Only use oil that meets the Liebherr specifications.
-

- ▶ Top up appropriate amount of engine oil via filler pipe cover 1. (For more information see: [030.3.5 Engine oils, page 030-15](#))
- ▶ Do not fill diesel engine oil above maximum level.
- ▶ Clean cover 1, place it on filler pipe and close it.

030.4.4.2 Diesel engine: changing the diesel engine oil

Valid for: L504-1851;

Make sure the following prerequisites are met:

- Machine is in maintenance position 1.
- Service access is open.
- Diesel engine is warm.
- Suitable protective equipment is used.

Make sure that following tools are ready:

- Receptacle (15 l)

Make sure that following consumables are ready:

- Engine oil according to lubricant table. (For more information see: [030.2.1 Lubricant filling quantity, page 030-12](#))

Diesel engine: adjusting valve clearance

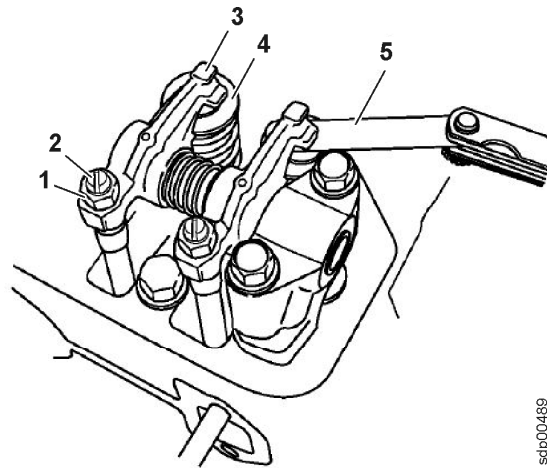

scfp00489

Fig. 118: Adjusting valves

- | | | | |
|---|-----------------|---|--------------|
| 1 | Counter nut | 4 | Tappet |
| 2 | Adjusting screw | 5 | Feeler gauge |
| 3 | Rocker arm | | |

- ▶ Unscrew the counter nut 1.
- ▶ Turn adjusting screw 2.
- ▶ Check valve clearance again and correct it if necessary.
- ▶ Tighten counter nut 1.

After completing testing and adjustment:

- ▶ Check components and valve cover for damage.
- ▶ Replace the valve cover seal.
- ▶ Replace O-rings on bolts of valve cover.
- ▶ Attach valve cover and accessories.

Cleaning the main element

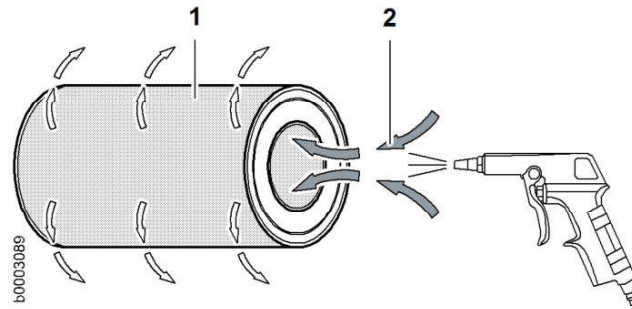

Fig. 128: Cleaning the main element

- | | |
|----------------|------------------|
| 1 Main element | 2 Compressed air |
|----------------|------------------|

NOTICE

Incorrect cleaning!
Damage to the main element.

- ▶ Use compressed air at low pressure.
 - ▶ Clean the main element with clean, oil-free compressed air.
 - ▶ Do not knock out the main element.
-
- ▶ Clean the main element 1 from the inside out with compressed air 2.

Cleaning the service cover and filter housing

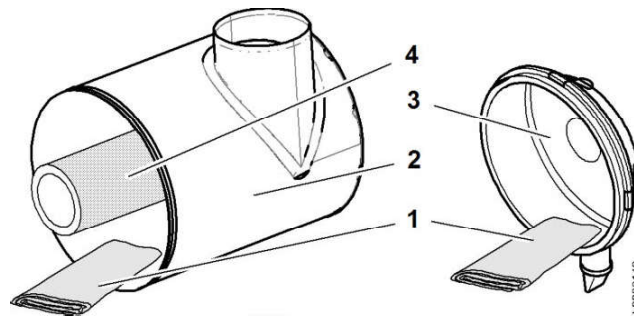

Fig. 129: Cleaning the service cover and filter housing

- | | |
|------------------|------------------|
| 1 Cloth | 3 Service cover |
| 2 Filter housing | 4 Safety element |

NOTICE

Incorrect cleaning!
Damage to the engine.

- ▶ Clean the filter housing with compressed air.
 - ▶ Wipe the filter housing with a clean cloth.
-
- ▶ Clean the inside of the filter housing 2 and the service cover 3 with a cloth 1.

CLICK HERE TO **DOWNLOAD** THE COMPLETE MANUAL

- Thank you very much for reading the preview of the manual.
- You can download the complete manual from: www.heydownloads.com by clicking the link below



- Please note: If there is no response to CLICKING the link, please download this PDF first and then click on it.

CLICK HERE TO **DOWNLOAD** THE COMPLETE MANUAL

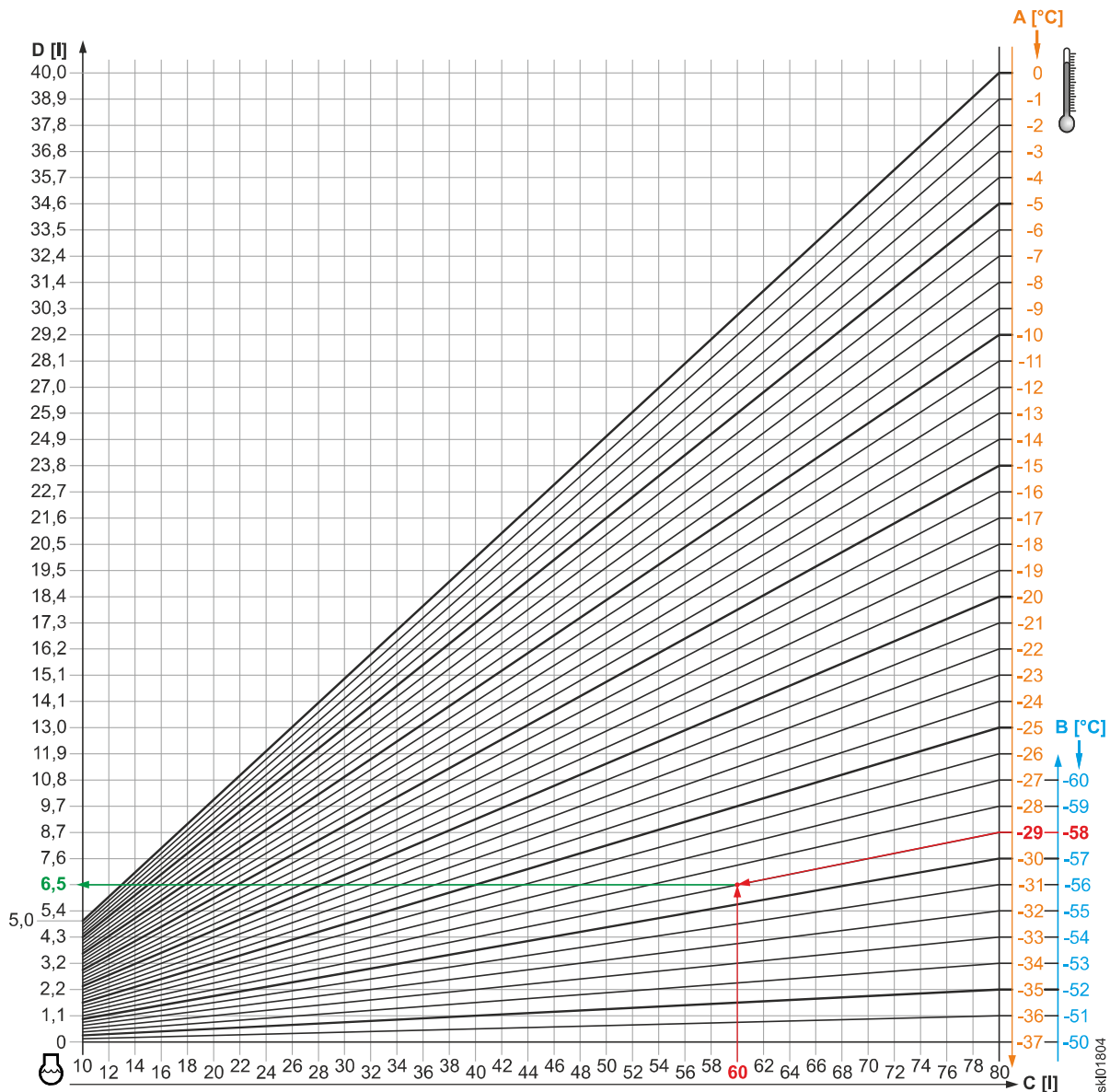

Fig. 138: Coolant diagram

- A** Freezing point - orange scale: top up with pure antifreeze and corrosion inhibitor
- B** Freezing point - blue scale: top up with pure water
- C** Total capacity of the cooling system
- D** Amount to top up

- ▶ Enter the identified freezing point on the orange scale **A** or the blue scale **B**.
- ▶ Enter total capacity of the cooling system **C**. (For more information see: [030.2.1 Lubricant filling quantity, page 030-12](#))
- ▶ From where the two lines cross, follow a horizontal line to read off the amount to top up **D**.

Example 1:

- ▶ Identified freezing point = -29 °C.
- ▶ Total capacity of the cooling system = 60 l.

LBH/12278872/00/211-20220210_134616/en

Topping up the oil



Note

To top up the oil:

- ▶ Put the machine in maintenance position 1.
- ▶ Always pour in oil through return strainer.
- ▶ Oil specification:

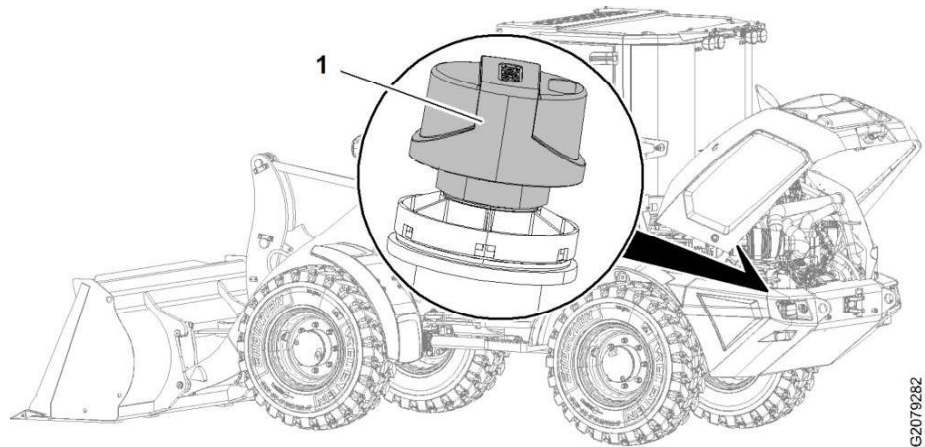

Fig. 148: Topping up the oil

1 Breather filter

- ▶ Unscrew breather filter 1 from hydraulic tank.

NOTICE

Non-approved oil!
Damage to the hydraulic system.

- ▶ Only use oil that meets the Liebherr specifications.
- ▶ Do not mix different oils.

- ▶ Top up appropriate amount of hydraulic oil via filler strainer of breather filter 1.
- ▶ Screw in the breather filter 1.

030.4.6.2 Hydraulic tank: draining off condensate and sediment

Valid for: L504-1851;

Make sure the following prerequisites are met:

- Machine has not been started for at least an hour.
- Machine is in maintenance position 1.
- Service access is open.

Make sure that following tools are ready:

- Drain hose
- Receptacle

- ▶ Clean the cover 2.
- ▶ Put cover 2 back onto equalising reservoir 1 and close it.

030.4.8.3 Checking gap and wear on service brake linings

Valid for: L504-1851;

Make sure the following prerequisites are met:

- Machine is in maintenance position 2.

Make sure that following tools are ready:

- Feeler gauge



WARNING

Beware of machine rolling away!
Accidents.

- ▶ Make sure machine is parked on level ground.
- ▶ Use chocks to secure machine against rolling away.

Preparations

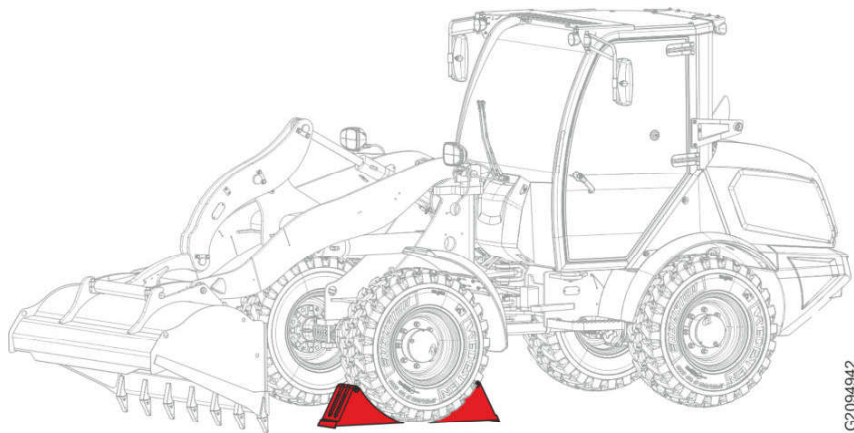

G2094942

Fig. 160: Preparations

- ▶ Use chocks to secure machine against rolling away.
- ▶ Release parking brake.

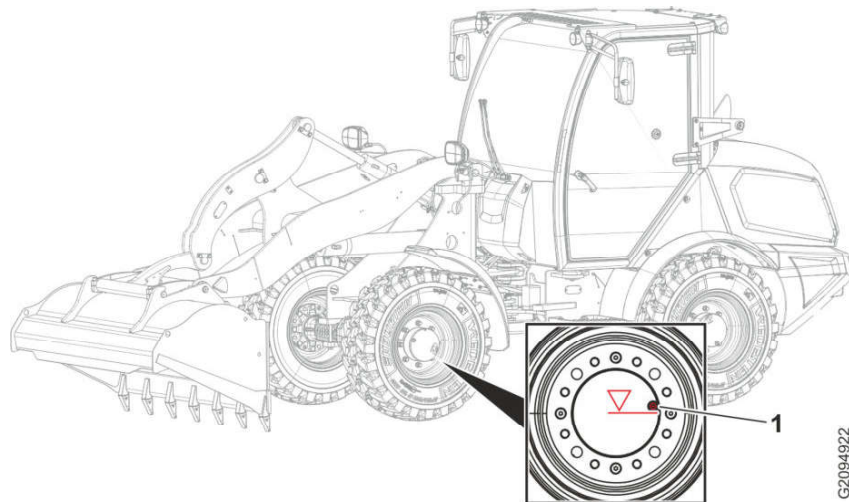

GZ094922

Fig. 171: Checking oil level in wheel hubs

1 Maintenance plug (4x)

- ▶ Park machine so that oil level marking on left wheel hub of front axle is to the right (maintenance plug 1 at 3 o'clock).
- ▶ Put the machine in maintenance position 2.
- ▶ Carefully open maintenance plug 1 on left wheel hub of front axle.
- ▶ Check that the oil level is up to the bottom of the opening.

If oil level is too low:

- ▶ Check wheel hub for leaks.
- ▶ Top up oil through openings in maintenance plug 1 until oil level reaches the bottom of the opening.

If the oil level is correct:

- ▶ Screw in maintenance plug 1 and apply tightening torque of 50 Nm.
- ▶ Repeat the process for the other wheel hubs.

030.4.11.2 Changing axle oil

Valid for: L504-1851;

Make sure the following prerequisites are met:

- Oil is at operating temperature.
- Machine is in maintenance position 2.

Make sure that following tools are ready:

- Receptacle
- Torque wrench

Make sure that following consumables are ready:

- Axle oil according to table of lubricants.



Note

Information on oil specification:

- ▶ See "Lubricants and fuels: Axle lubricants". (For more information see: [030.3.10 Axle oil, page 030-18](#))

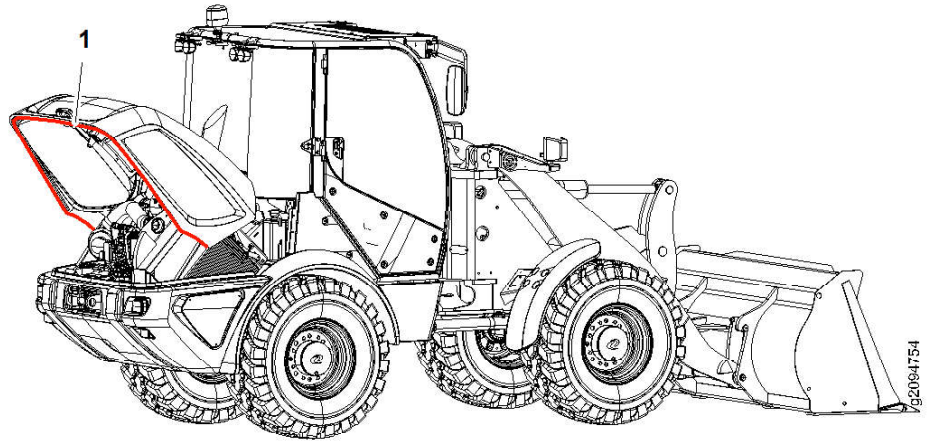

Fig. 183: Service hatches: cleaning and maintaining seals

1 Engine bonnet seal

- ▶ Wipe seal 1 with a damp cloth.
- ▶ Apply silicon spray to the seal 1.

030.4.13 Working attachment

030.4.13.1 Lubricating the lift arms and working attachment

Valid for: L504-1851;

For jobs that require daily cleaning, the lift arms and attachment must be lubricated every day.

Make sure the following preconditions are met:

- Machine is in maintenance position 2.
- The working attachment is disconnected for lubricating points near the bucket coupling, which are difficult to access.
- The lubricating point has been cleaned.

**Note**

V-belt tension is set at factory and must be retightened when belt tension decreases.

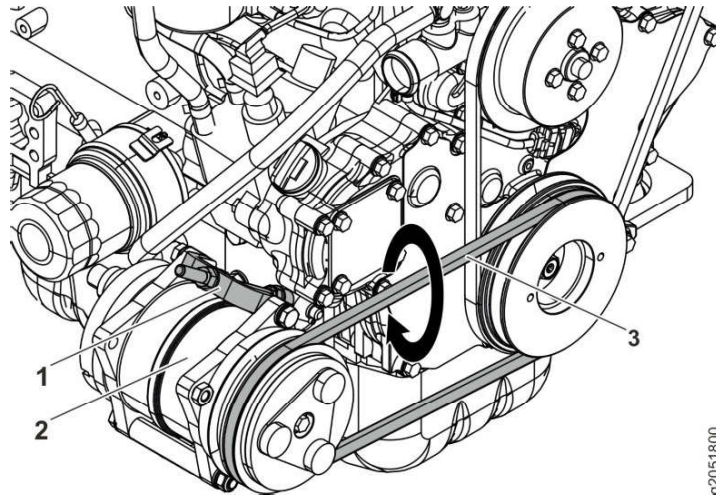

Fig. 194: Checking V-belt tension

- | | |
|---|---|
| <p>1 Tensioning device</p> <p>2 Air conditioning compressor</p> | <p>3 V-belt of compressor magnetic coupling</p> |
|---|---|

V-belt tension is checked in middle of V-belt 3.

- ▶ Turn V-belt 3 90° with thumb, index finger and moderate force.
 - ▷ V-belt 3 can be turned about 90°.
 - ▷ V-belt tension is correct.

If V-belt 3 can be turned more than 90°:

- ▶ Set V-belt tension. (For more information see: [Setting V-belt tension, page 030-131](#))

Setting V-belt tension

Make sure that following requirements are met:

- Machine is in maintenance position 1.
- Diesel engine has cooled down.
- Service access is open.

060 Working hydraulics

Contents

060.1 Overview of working hydraulics
L504-1851;

060-2

| | | | | | |
|-----------|---|-----------|----------------------------|-----------|---|
| 6 | Hydraulic oil drain valve | 18 | Inch/brake unit | 30 | Tilt cylinder |
| 7 | Return filter | 19 | Main brake cylinder | 31 | Quick coupler for 1st additional function (2x) |
| 8 | Solenoid valve for relieving pressure on the working pump | 20 | Equalising reservoir | 32 | Open solenoid valve for quick coupler |
| 9 | Orifice 1.8 mm | 21 | Filler strainer | 33 | Quick coupler locking hydraulic cylinder |
| 10 | Working pump | 22 | Drum brake | 34 | Quick coupler for 2nd additional function (2x) (option) |
| 11 | Travel pump | 23 | <i>Parking brake</i> lever | 35 | Quick coupler for leak oil line (option) |
| 12 | Valve block for travel direction | 24 | Check valve | | |

| Name | Test point | Name | Test point | Name | Test point |
|----------|-----------------------|-----------|---------------------------|-----------|----------------------------------|
| G | Replenishing pressure | MH | Travel pump high pressure | PA | Working hydraulics high pressure |

Tab. 72: Test points

| BMK | Function | BMK | Function | BMK | Function |
|-------------|--------------------------------------|-------------|--|-------------|---|
| B5 | Switch for parking brake | S2a | Retaining magnet for working hydraulics lockout (2x) | Y34b | Proportional solenoid for 2nd additional function B |
| B8 | Temperature switch for hydraulic oil | Y2 | Forward travel direction solenoid | Y20 | Solenoid for ride control |
| B12 | Brake light pressure switch | Y3 | Reverse travel direction solenoid | Y53 | Solenoid for opening quick coupler |
| B101 | Output speed sensor | Y33a | Proportional solenoid for 1st additional function A | Y106 | Servo pressure proportional solenoid |
| B102 | Travel pump high pressure sensor | Y33b | Proportional solenoid for 1st additional function B | | |
| R1 | Inching function angle sensor | Y34a | Proportional solenoid for 2nd additional function A | | |

Tab. 73: Equipment codes

110 Electrical system

Contents

| | | |
|-------|---------------------------------------|-------|
| 110.1 | Circuit diagrams <i>L504-1851;</i> | 110-2 |
|-------|---------------------------------------|-------|

| BMK | SYSTEM | LOCATION | FUNCTION | PAGE | BMK | SYSTEM | LOCATION | FUNCTION | PAGE |
|----------|--------|----------|---|------------|---------|--------|----------|---|------------|
| -S2b.X11 | =K | +K4 | CONNECTOR CONTROL LEVER MINI-JOYSTICK | /15.E7 | -S46 | =K | +K4 | REAR WINDOW AND MIRROR HEATER SWITCH REAR WINDOW HEATER | /30.C7 |
| -S3 | =K | +K1 | STEERING COLUMN SWITCH | /25.D8 | -S46.X | =K | +K4 | CONNECTOR REAR WINDOW AND MIRROR HEATER SWITCH | /30.C6 |
| -S3.X1 | =K | +K1 | CONNECTOR STEERING COLUMN SWITCH | /25.D8 | -S56.X | =K | +K4 | CONNECTOR SWITCH RETURN LINE CAN BE SWITCHED PRESSURELESS | /72.D3 |
| -S3.X2 | =K | +K1 | CONNECTOR STEERING COLUMN SWITCH | /25.D8 | -S57 | =K | +K4 | SWITCH RETURN LINE CAN BE SWITCHED PRESSURELESS | /72.C3 |
| -S4 | =K | +K4 | HAZARD WARNING SYSTEM SWITCH | /20.B2 | -S58a | =K | +K4 | CONTROL LEVER LOCK BUTTON | /59.C5 |
| -S4.X | =K | +K4 | CONNECTOR HAZARD WARNING SYSTEM SWITCH | /20.B2 | -S58a.X | =K | +K4 | CONNECTOR CONTROL LEVER LOCK BUTTON | /59.D5 |
| -S4a | =K | +K4 | HAZARD WARNING SYSTEM | /20.B1 | -S300 | =K | +K4 | FLASHING LIGHT SWITCH | /56.C6 |
| -S6 | =K | +K6 | PARKING LIGHT AND LOW BEAM SWITCH | /25.A1 | -S300.X | =K | +K4 | CONNECTOR FLASHING LIGHT SWITCH | /56.D7 |
| -S6.X | =K | +K6 | CONNECTOR PARKING LIGHT AND LOW BEAM SWITCH | /25.B1 | -S301 | =K | +K4 | VARIABLE SPEED LIMIT AND FIXED SPEED BUTTON | /62.C2 |
| -S7 | =K | +K4 | FRONT WORKING HEADLIGHTS SWITCH | /24.D5 | -S301.X | =K | +K4 | CONNECTOR VARIABLE SPEED LIMIT AND FIXED SPEED BUTTON | /62.D2 |
| -S7.X | =K | +K4 | CONNECTOR FRONT WORKING HEADLIGHTS SWITCH | /24.D4 | -S303 | =K | +K4 | SWITCH REAR ADDITIONAL FUNCTION | /62.C5 |
| -S8 | =K | +K4 | REAR WORKING HEADLIGHTS SWITCH | /23.D3 | -S303.X | =K | +K4 | CONNECTOR SWITCH REAR ADDITIONAL FUNCTION | /62.D5 |
| -S8.X | =K | +K4 | CONNECTOR REAR WORKING HEADLIGHTS SWITCH | /23.E3 | -S305 | =K | +K4 | OPTION ADDITIONAL FUNCTIONS PRESSURE RELIEF KEY | /12.C8 |
| -S8a | =K | +K4 | REAR WORKING HEADLIGHTS SWITCH MULTIFUNCTIONAL | /23.D5 | -S305.X | =K | +K4 | CONNECTOR OPTION ADDITIONAL FUNCTIONS PRESSURE RELIEF KEY | /12.C8 |
| -S8a.X | =K | +K4 | CONNECTOR REAR WORKING HEADLIGHTS SWITCH MULTIFUNCTIONAL | /23.E5 | -S323 | =K | +K4 | SWEEPER SWITCH | /64.D6 |
| -S9 | =K | +K4 | FLASHING BEACON SWITCH | /53.C3 | -S323.X | =K | +K4 | CONNECTOR SWEEPER SWITCH | /64.E6 |
| -S9.X | =K | +K4 | CONNECTOR FLASHING BEACON SWITCH | /53.D2 | -S323a | =K | +K4 | SWEEPER SWITCH | /64.D7 |
| -S9a | =K | +K4 | FLASHING BEACON SWITCH MULTIFUNCTIONAL | /53.C4 | -S501 | =K | +K | SWITCH SKID STEER | /71.C2 |
| -S9a.X | =K | +K4 | CONNECTOR FLASHING BEACON SWITCH MULTIFUNCTIONAL | /53.C5 | -S501.X | =K | +K | CONNECTOR SWITCH SKID STEER | /71.C2 |
| -S13 | =K | +K4 | REAR WINDOW WASHER SYSTEM SWITCH | /22.C4 | -S502 | =K | +K | REAR WINDOW WASHER SYSTEM SWITCH | /22.C3 |
| -S13.X | =K | +K4 | CONNECTOR REAR WINDOW WASHER SYSTEM SWITCH | /22.C4 | -S503 | =K | +K4 | SWITCH CENTRAL LUBRICATION SYSTEM | /58.B2 |
| -S15 | =H | +H4 | BATTERY MAIN SWITCH | /12.E4 | -S503 | =K | +K | AUDIBLE REVERSING ALARM SWITCH | /65.F8 |
| -S16 | =K | +K | RIDE CONTROL BUTTON | /28.C3 | -S503.X | =K | +K4 | CONNECTOR CENTRAL LUBRICATION SYSTEM | /58.B2 |
| -S16.X | =K | +K | CONNECTOR RIDE CONTROL BUTTON | /28.C3 | -S700 | =K | +K4 | SWITCH DPF REGENERATION | /35.E2 |
| -S17 | =K | +K4 | PARKING BRAKE BUTTON | /34.C2 | -S700.X | =K | +K4 | CONNECTOR SWITCH DPF REGENERATION | /35.E2 |
| -S17.X | =K | +K4 | CONNECTOR PARKING BRAKE BUTTON | /34.D2 | -S701 | =K | +K4 | VARIABLE SPEED LIMIT AND FIXED SPEED BUTTON | /65.C4 |
| -S19 | =K | +K4 | WORKING HYDRAULICS LOCKOUT BUTTON | /28.C8 | -S702 | =K | +K4 | SWITCH REAR ADDITIONAL FUNCTION | /65.C6 |
| -S19.X | =K | +K4 | CONNECTOR WORKING HYDRAULICS LOCKOUT BUTTON | /28.C7 | -S703 | =K | +K4 | SWITCH RETURN LINE CAN BE SWITCHED PRESSURELESS | /65.F8 |
| -S20 | =K | +K4 | TRAVEL RANGE BUTTON | /19.C6 | -T3 | =K | +K4 | USB CHARGING PORT | /30.D2 |
| -S20.X | =K | +K4 | CONNECTOR TRAVEL RANGE BUTTON | /19.C6 | -T3.X | =K | +K4 | | /30.E2 |
| -S23 | =K | +K4 | SWITCH QUICK COUPLER | /33.C7 | -V2 | =K | +K | BLOCKING DIODE FORWARD TRAVEL DIRECTION | /16.C3 |
| -S23.X | =K | +K4 | CONNECTOR SWITCH QUICK COUPLER | /33.D7 | -V3 | =K | +K | BLOCKING DIODE REVERSE TRAVEL DIRECTION | /16.C4 |
| -S43 | =K | +K | AUDIBLE REVERSING ALARM SWITCH | =K+K/14.C3 | -V6 | =K | +K4 | BLOCKING DIODE WARNING BUZZER | =K+K/13.B7 |
| -S43.X | =K | +K | CONNECTOR AUDIBLE REVERSING ALARM SWITCH | =K+K/14.C3 | -V7 | =K | +K4 | BLOCKING DIODE WARNING BUZZER | =K+K/13.B8 |
| -S45a | =K | +K4 | 1ST ADDITIONAL FUNCTION / 2ND ADDITIONAL FUNCTION ACTIVATION SWITCH | /60.B6 | -V83 | =K | +K2 | BLOCKING DIODE | /20.D3 |
| -S45a.X | =K | +K4 | CONNECTOR 1ST ADDITIONAL FUNCTION / 2ND ADDITIONAL FUNCTION ACTIVATION SWITCH | /60.C6 | -V84 | =K | +K2 | BLOCKING DIODE | /20.D3 |

12892819
ITEM CODE
DRAWING INDEX
001

Serie
1853 0090 01 00
DRAWING NUMBER

PROJECT
ISO 19016: The reproduction is prohibited, distribution and utilization of its contents to others without express authorization are prohibited. Violations require compensation. All rights reserved in the case of patent, utility model or design registration.

TRAVEL RANGE

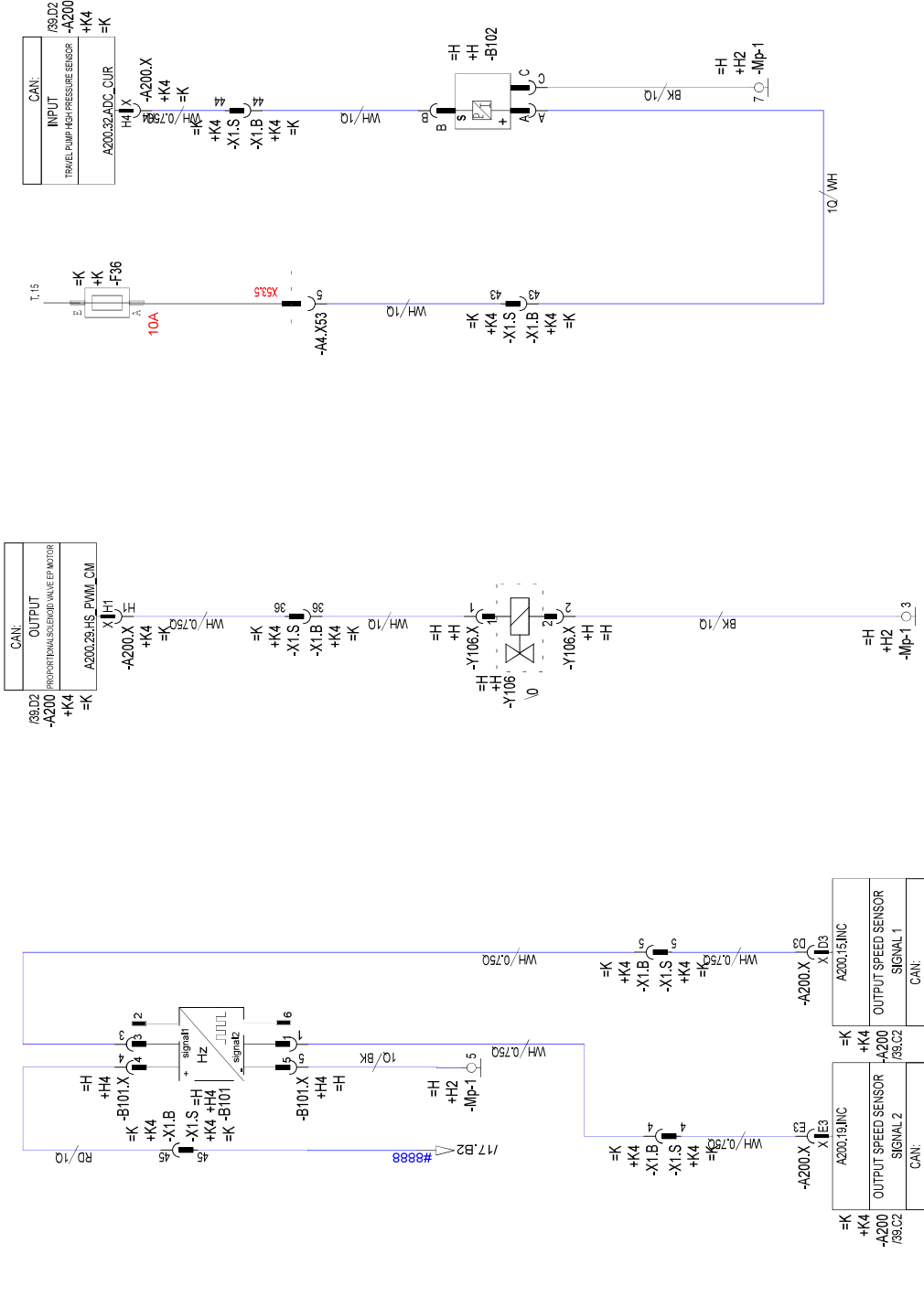

12892819
001

ITEM CODE
DRAWING INDEX

Serie
1853 0090 01 00

PROJECT
DRAWING NUMBER

ISO 15018: The reproduction is prohibited, distribution is prohibited, and utilization of this document as well as the communication of its contents to others without express authorization is prohibited. Violations require compensation. All rights reserved in the case of patent, utility model or design registration.

MACHINE TYPE

SERIAL NUMBER

LIEBHERR
FACTORY LBH

TRAVEL RANGE OUTPUT SPEED SENSOR
E-SCHEMA

PAGE 18 OF

CREATION DATE 22.10.2021 11:18

RESERVE FUSE RESERVE RELAY

ITEM CODE 12892819
DRAWING INDEX 001

Serie 1853 0090 01 00
DRAWING NUMBER

PROJECT

ISO 19016: The reproduction is prohibited, distribution and utilization of this document as well as the communication of its contents to others without express authorization is prohibited. Violations require compensation. All rights reserved in the case of patent, utility model or design registration.

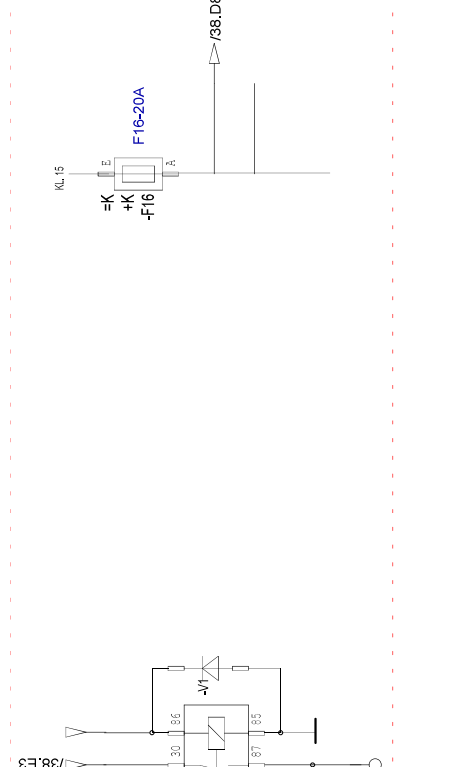
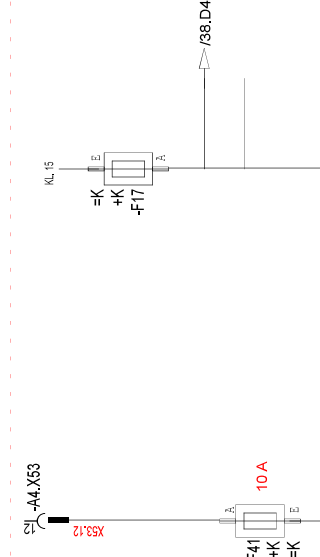
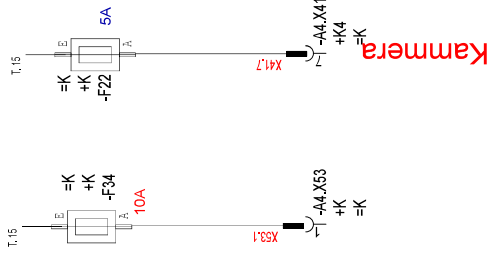
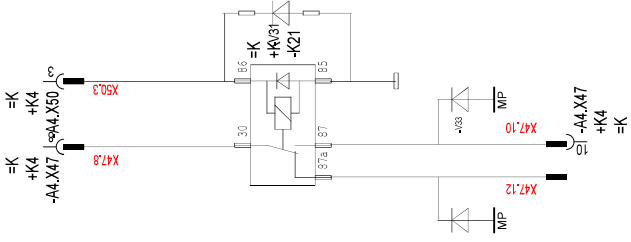
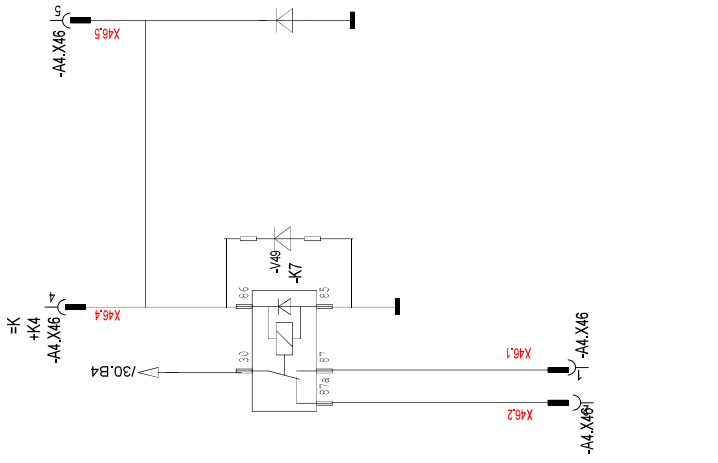

MACHINE TYPE

SERIAL NUMBER

RESERVE FUSE RESERVE RELAY
E-SCHEMA

PAGE 38 OF

CREATION DATE 22.10.2021 11:18

LIEBHERR
FACTORY LBH

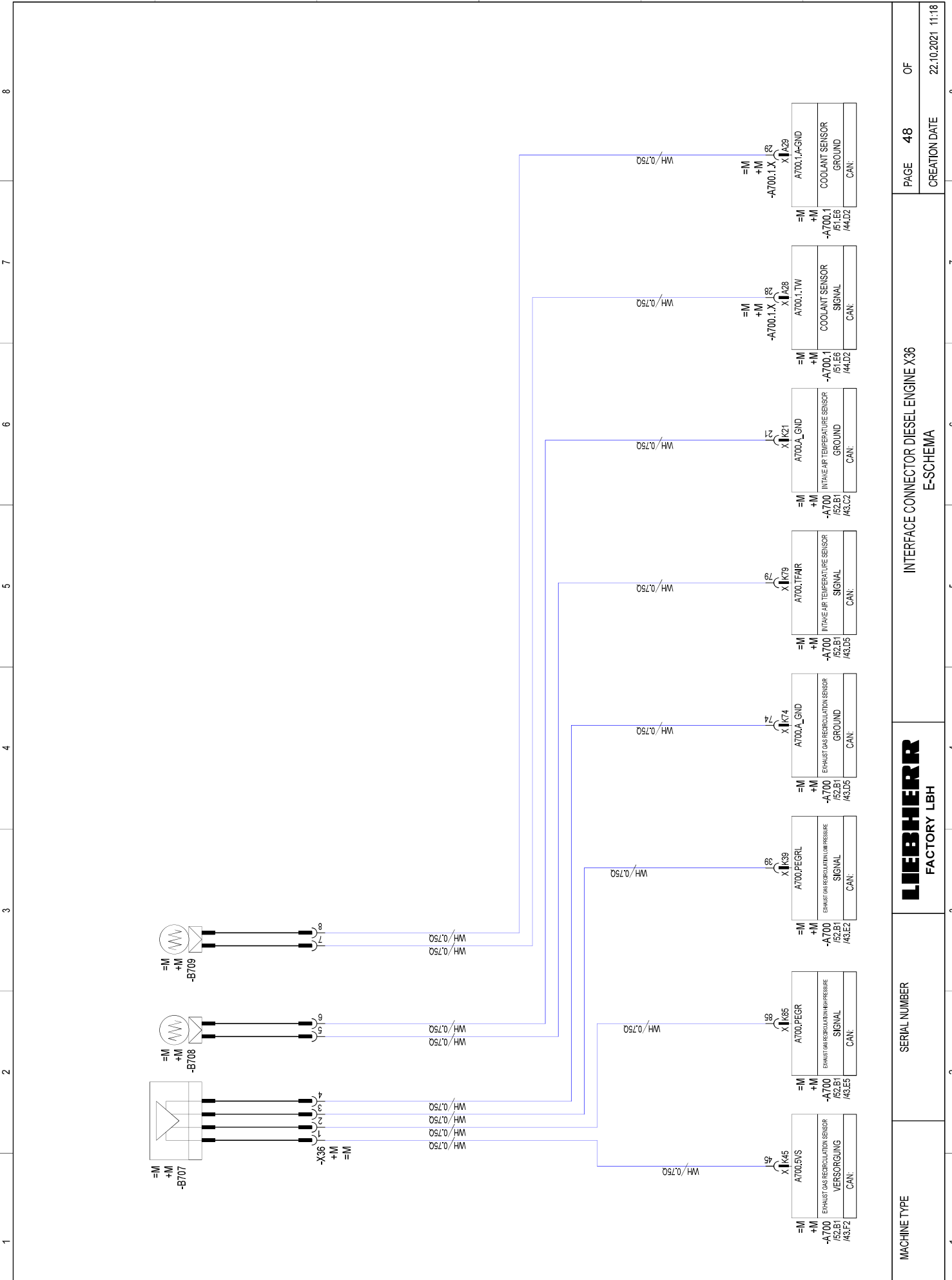

PROJECT: Serie 1853 0090 01 00
 DRAWING NUMBER: 12892819
 ITEM CODE: 001
 DRAWING INDEX: 001

ISO 18018: The reproduction, distribution and utilization of this document as well as the communication of its contents to others without express authorization is prohibited. Violations require compensation. All rights reserved in the case of patent, utility model or design registration.

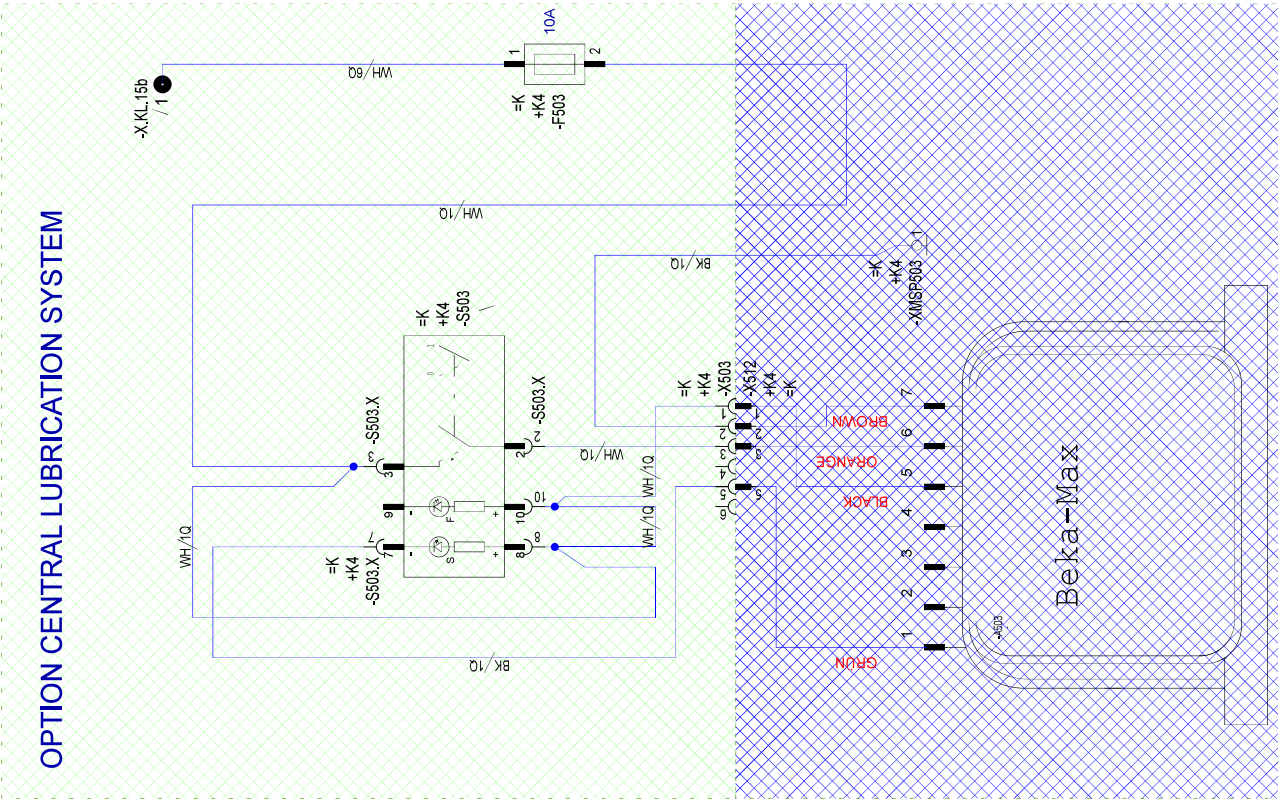

OPTION CENTRAL LUBRICATION SYSTEM

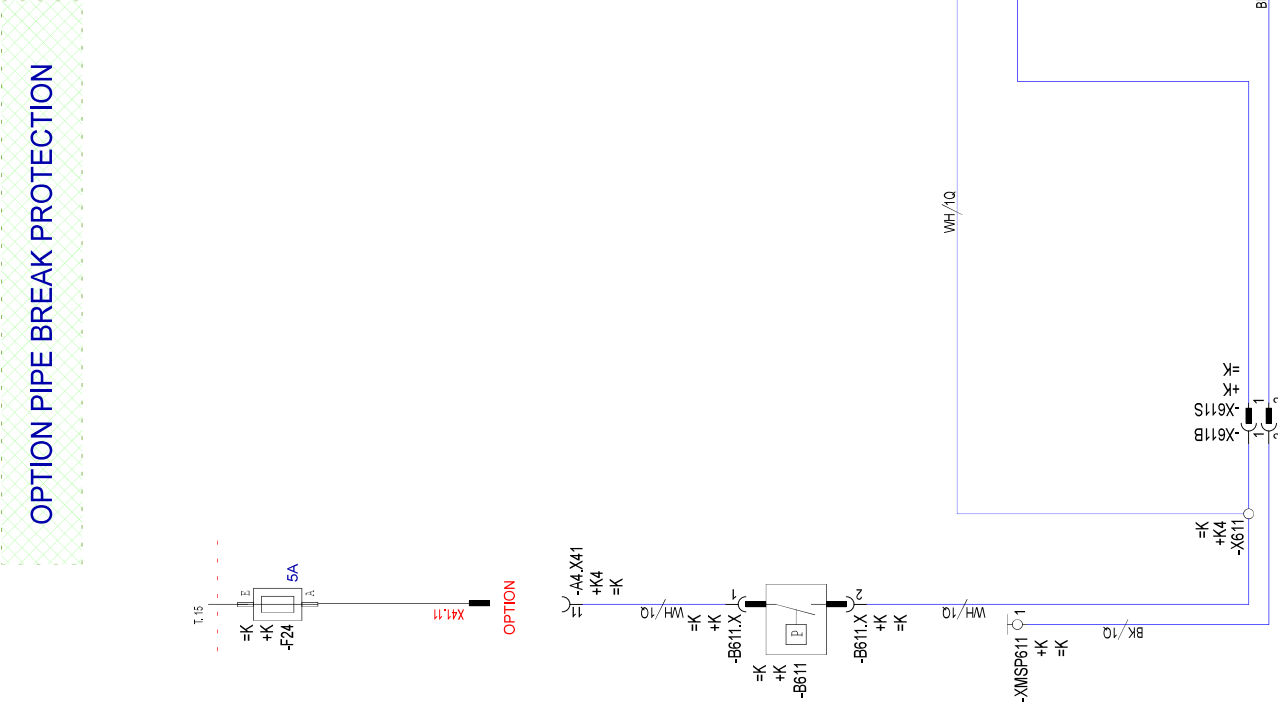

OPTION PIPE BREAK PROTECTION

12892819

ITEM CODE DRAWING INDEX 001

Serie 1853 0090 01 00

PROJECT DRAWING NUMBER

ISO 19018: The reproduction is prohibited, distribution and utilization of its contents to others without express authorization require compensation. All rights reserved in the case of patent, utility model or design registration.

MACHINE TYPE

SERIAL NUMBER

KS 12269914

LIEBHERR
FACTORY LBH

OPTION CENTRAL LUBRICATION SYSTEM PIPE BREAK PROTECTION
E-SCHEMA

PAGE 58

OF

CREATION DATE

22.10.2021 11:18

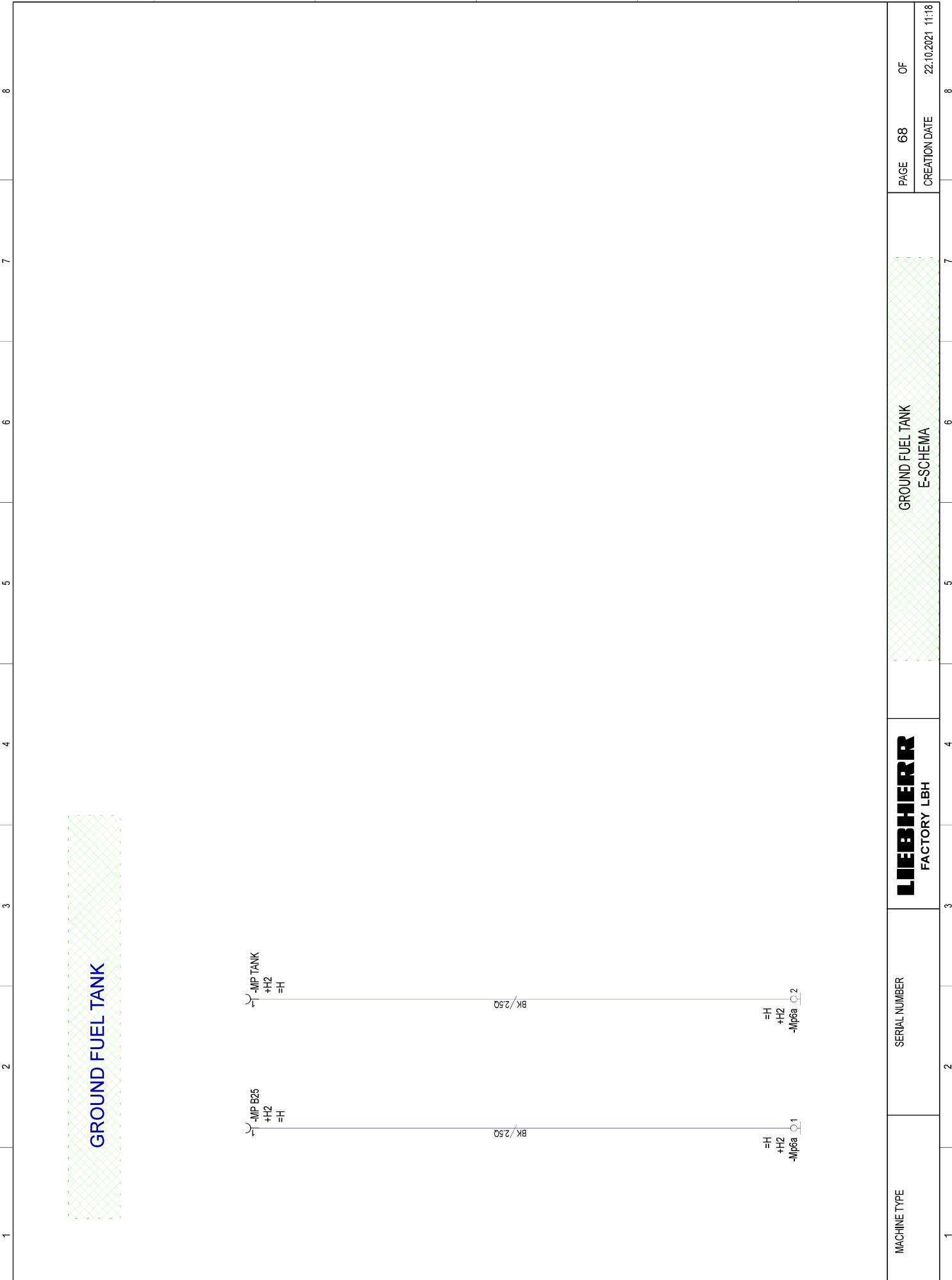

GROUND FUEL TANK

| | | | | | | |
|--------------|---------------|---|--|------------------|---------|----|
| MACHINE TYPE | SERIAL NUMBER |  | | GROUND FUEL TANK | PAGE 68 | OF |
| | | | | E-SCHEMA | | |

12892819 ITEM CODE
 001 DRAWING INDEX
 Serie 1853 00090 01 00
 PROJECT 1853 00090 01 00 DRAWING NUMBER
 registration. ISO 19018. The reproduction is prohibited, distribution and utilisation of this document as well as the communication of its contents to others without express authorization is prohibited. Violations require compensation. All rights reserved in the case of patent, utility model or design.

CLICK HERE TO **DOWNLOAD** THE COMPLETE MANUAL

- Thank you very much for reading the preview of the manual.
- You can download the complete manual from: www.heydownloads.com by clicking the link below



- Please note: If there is no response to CLICKING the link, please download this PDF first and then click on it.

CLICK HERE TO **DOWNLOAD** THE COMPLETE MANUAL