

# SHOP MANUAL

---

---

---

# WB70A-1

**BACKHOE-LOADER**

SERIAL NUMBER

**WB70A-1 F10392** and up

CLICK HERE TO **DOWNLOAD** THE COMPLETE MANUAL

- Thank you very much for reading the preview of the manual.
- You can download the complete manual from: [www.heydownloads.com](http://www.heydownloads.com) by clicking the link below



- Please note: If there is no response to CLICKING the link, please download this PDF first and then click on it.

CLICK HERE TO **DOWNLOAD** THE COMPLETE MANUAL

# HOISTING INSTRUCTIONS

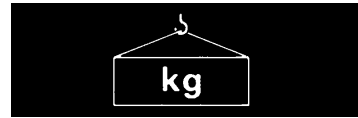

**⚠** Heavy parts (25 kg or more) must be lifted with a hoist etc. In the **Disassembly and Assembly** section, every part weighing 25 kg or more is clearly indicated with the symbol 

1. If a part cannot be smoothly removed from the machine by hoisting, the following checks should be made:
  - Check for removal of all bolts fastening the part to the relative parts.
  - Check for any part causing interference with the part to be removed.

## 2. Wire ropes

- 1) Use adequate ropes depending on the weight of parts to be hoisted, referring to the table below:

WIRE ROPES (Standard «S» or «Z» twist ropes without galvanizing)	
Rope diameter (mm)	Allowable load (tons)
10	1.0
11.2	1.4
12.5	1.6
14	2.2
16	2.8
18	3.6
20	4.4
22.4	5.6
30	10.0
40	18.0
50	28.0
60	40.0

The allowable load value is estimated to be one-sixth or one-seventh of the breaking strength of the rope used.

- 2) Sling wire ropes from the middle portion of the hook. Slinging near the edge of the hook may cause the rope to slip off the hook during hoisting,

and a serious accident can result. Hooks have maximum strength at the middle portion.

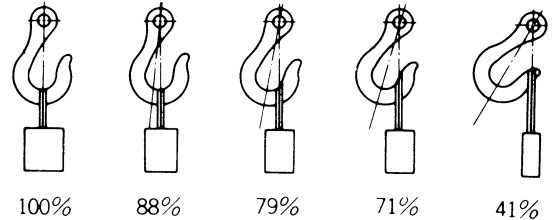

- 3) Do not sling a heavy load with one rope alone, but sling with two or more ropes symmetrically wound on to the load.

**⚠** Slinging with one rope may cause turning of the load during hoisting, untwisting of the rope, or slipping of the rope from its original winding position on the load, which can cause dangerous accidents.

- 4) Do not sling a heavy load with ropes forming a wide hanging angle from the hook.

When hoisting a load with two or more ropes, the force subjected to each rope will increase with the hanging angles.

The table below shows the variation of allowable load (kg) when hoisting is made with two ropes, each of which is allowed to sling up to 1000 kg vertically, at various hanging angles.

When two ropes sling a load vertically, up to 2000 kg of total weight can be suspended.

This weight becomes 1000 kg when two ropes make a 120° hanging angle.

On the other hand, two ropes are subjected to an excessive force as large as 4000 kg if they sling a 2000 kg load at a lifting angle of 150°.

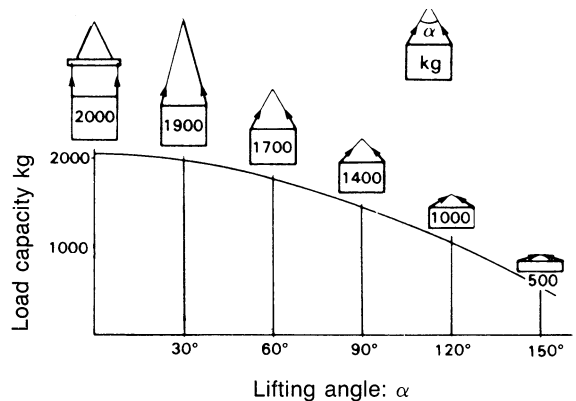

---

# 10 STRUCTURE AND FUNCTION

---

P.T.O. ....	2	Valves .....	40
Power train .....	3	Gear pump.....	42
Transmission .....	4	Outrigger safety valves .....	43
Axles .....	6	Brake pump.....	44
Hydrostatic transmission .....	12	Front equipment cylinder .....	46
Hydrostatic transmission pump .....	14	Front work equipment.....	48
Inching valve .....	22	Loader control lever.....	49
Travel motor .....	23	Backhoe cylinder .....	50
Steering system .....	28	Backhoe work equipment.....	54
Steering system pump.....	29	Backhoe control lever .....	55
Steering unit.....	30	Solenoid valve .....	56
Priority valve.....	31	Electrical diagram (1/5) .....	57
Frames knuckle and joint .....	32	Electrical diagram (2/5) .....	59
Hydraulic circuit diagram.....	33	Electrical diagram (3/5) .....	61
3-Spool control valve .....	35	Electrical diagram (4/5) .....	63
6-Spool control valve .....	36	Electrical diagram (5/5) .....	65
7-Spool control valve .....	38		



## 5 - SAFETY VALVES

The safety valves are used to protect the hydrostatic circuit from pressure peaks which exceed the maximum permissible value for hydraulic pump.

The valves are dual cartridge movable type, separating the low pressure line from the other high pressure line and both are fitted on delivery line.

When the restrictor (1) is opened, exceeding pressure is sent directly from high pressure line into low pressure line.

The safety valves must operate only in special case and only for a short time period because the oil leakage following the opening of the valve (1), produces heat and therefore the oil overheating inside the closed circuit.

The safety valves setting must be done on test bench and is obtained adjusting the restrictor (1) into the seat (2) of the contrast spring (3).

The position is fixed by the screw (4).

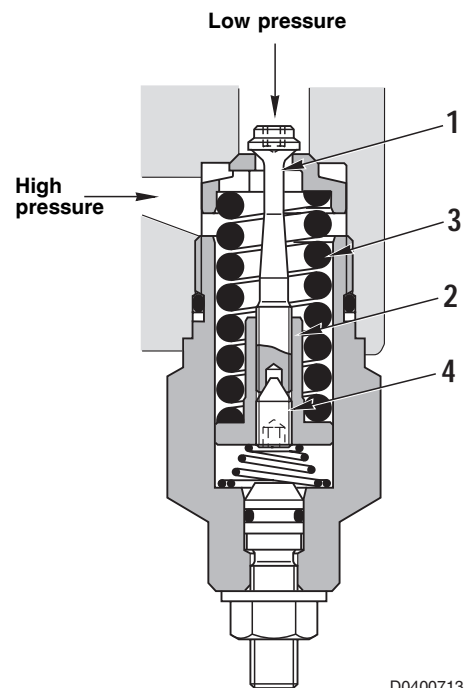

D0400713

# PRIORITY VALVE

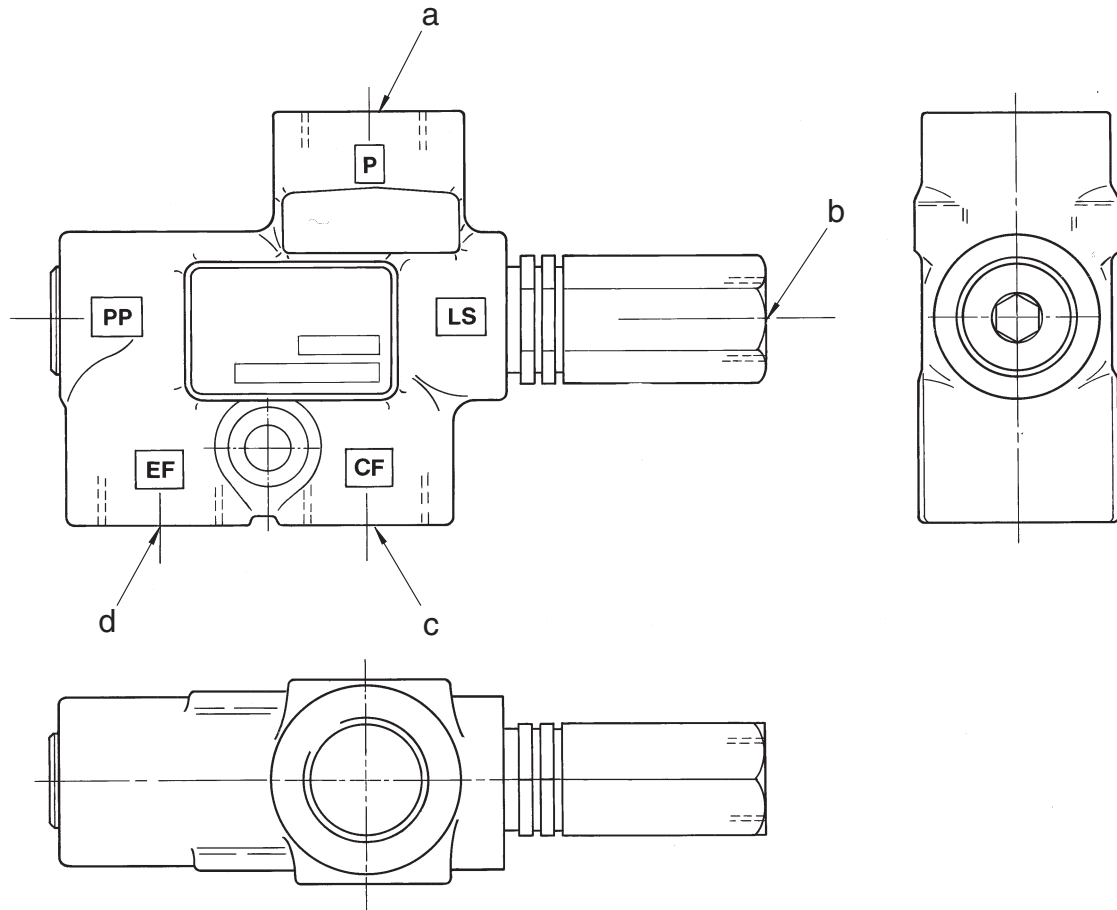

D0400036

- a. P Port - From pump P2 (P Port)
- b. LS Port - To steering unit (LS Port)
- c. CF Port - To steering unit (P Port)
- d. EF Port - To 3 spool control-valve (T2 Port)

## SPECIFICATIONS

Type: OLS 40

## OPERATION

- The oil from pump is distributed through the priority valve to the steering unit (**CF Port**) and to the other hydraulic components (**EF Port**).
- Distribution is determined by the position of the priority valve slider in function of:
  - a - the Load Sensing signal coming from the steering unit (**LS Port**);
  - b - the pump oil delivery;
  - c - the pressure in the steering system;
  - d - the pressure in the connected hydraulic circuit.
- The slider position is such as to ensure that delivery to the steering unit always corresponds to the actual requirements.

**SUCTION VALVE**

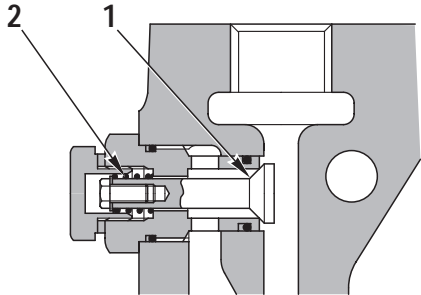

- 1. Valve
- 2. Spring
- 6-Spool control valve:
  - Bucket cylinder head side
  - Arm cylinder head side

RKZ03970

**CHECK VALVE**

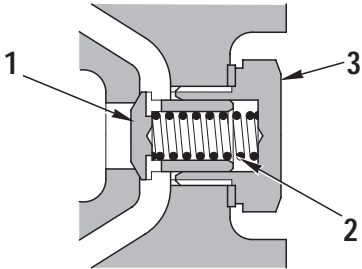

- 1. Check valve
- 2. Spring
- 3. Body valve

RKZ03390

**BOOM SWING**

★ The drawing shows R.H. boom swing cylinder

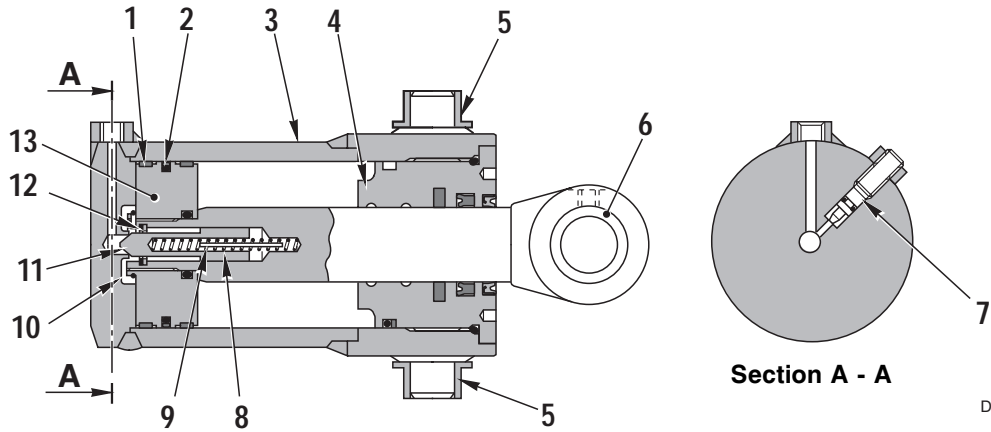

D0400680

- |                  |                 |                    |
|------------------|-----------------|--------------------|
| 1. Guide ring    | 6. Head bushing | 11. Pin            |
| 2. Piston ring   | 7. Throttling   | 12. Retaining ring |
| 3. Cylinder      | 8. Spring       | 13. Piston         |
| 4. Cylinder head | 9. Spring guide |                    |
| 5. Swing bushing | 10. Circlip     |                    |

**BACKFRAME LOCKING**

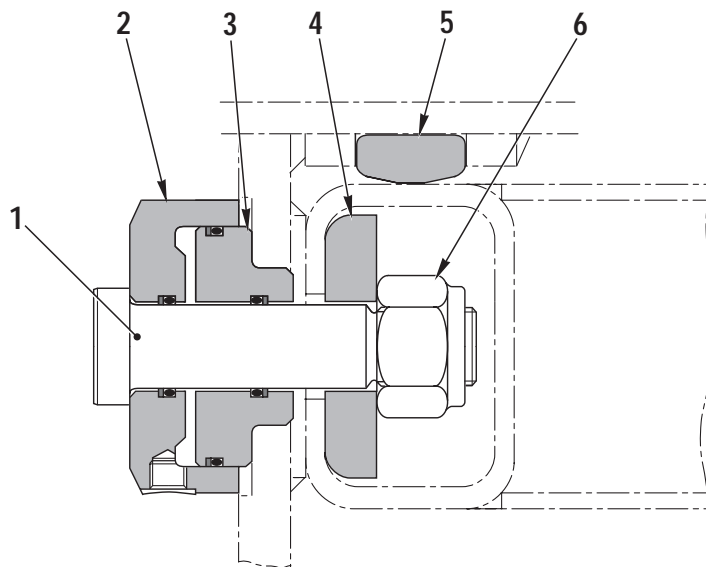

D0400686

- |             |                |                |
|-------------|----------------|----------------|
| 1. Rod      | 3. Piston      | 5. Sliding pad |
| 2. Cylinder | 4. Locking pad | 6. Nut         |

# ELECTRICAL DIAGRAM (3/5)

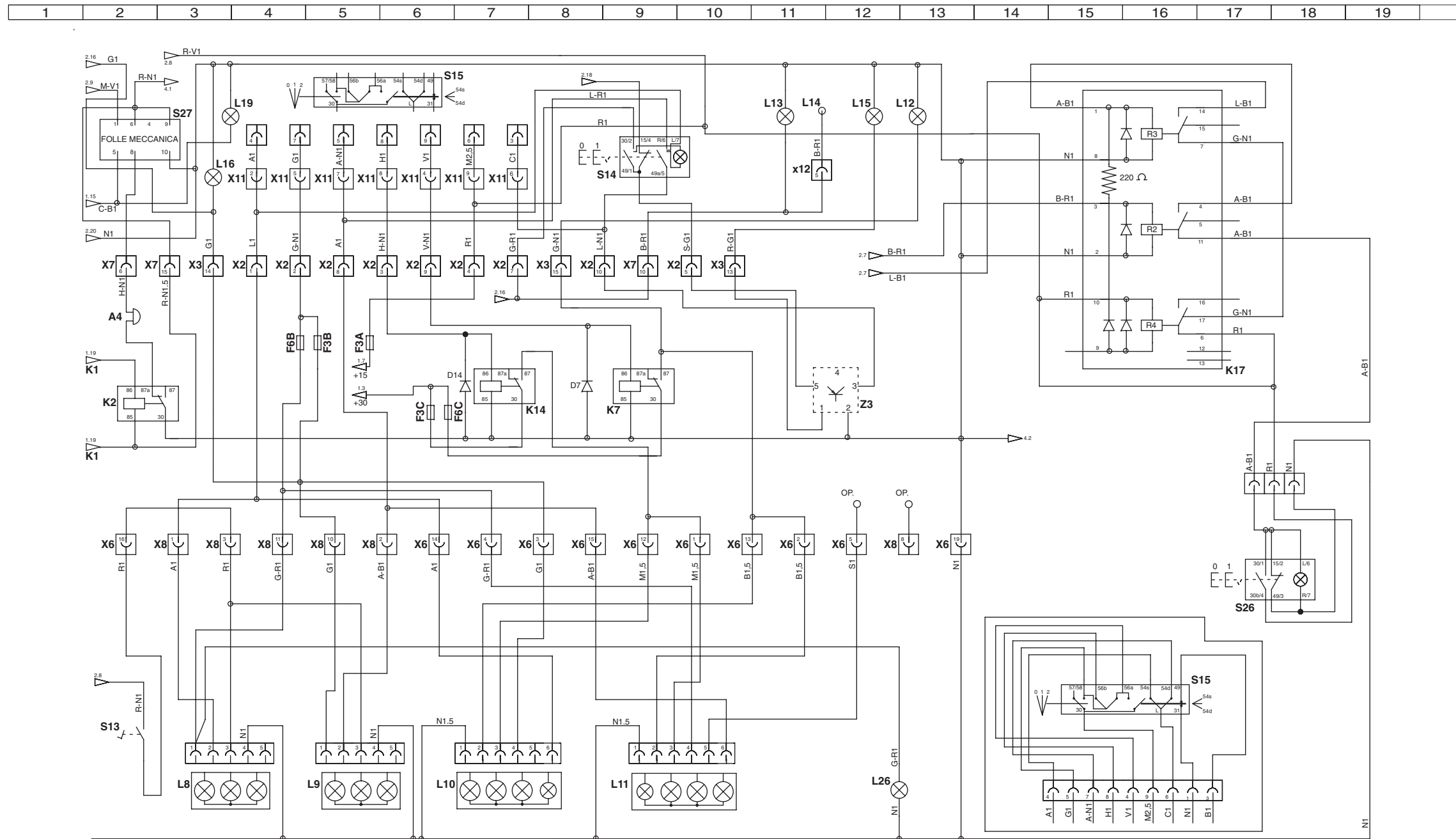

## COMPONENTS

- A4 - Buzzer
- K1 - Neutral mechanical relay
- K2 - Buzzer output
- K7 - Driving beam relay
- K14 - Lower beam relay
- K17 - Ride approval unit
- L8 - Rear L.H. beam
- L9 - Rear R.H. beam
- L10 - Front L.H. beam
- L11 - Front R.H. beam
- L12 - Driving beam light
- L13 - Roof light

- L14 - Car radio switch
- L15 - Direction indicator light
- L16 - Parking light
- L19 - Neutral pilot lamp
- L26 - Registration number light
- S13 - Brake switch
- S14 - Emergency warning switch
- S15 - Light switch
- S26 - Low-high selection switch
- S27 - Mechanical neutral
- Z3 - Flashing light

## FUSES

- F3A - Displacement change solenoid valve
- F3B - Tail light R.H. and panel light
- F3C - R.H. and L.H. lower beam
- F6B - L.H. parking light
- F6C - R.H. and L.H. driving beam

## CONNECTORS

- X2 - 13-ways connector dash-board line
- X3 - 21-ways connector dash-board black line
- X6 - 21-ways connector front line
- X7 - 17-ways connector cabin line
- X8 - 17-ways connector rear line
- X11 - 9-ways connector switch
- X12 - 13-ways connector upper line

● FOR MACHINE

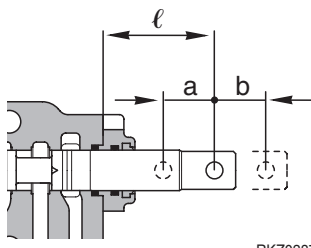
Machine model				WB70A-1						
Classification	Check item	Test conditions	Unit	Standard value			Permissible value			
Engine speed	With piston pump at max. pressure	<ul style="list-style-type: none"> <li>Hydraulic oil temperature: 55 – 65 °C.</li> <li>Engine oil temperature cooling circuit: in the limits</li> <li>Raised machine and working brakes applied in 2<sup>nd</sup> gear</li> </ul>	rpm	2620±50			Min. 2550			
	With piston pump and steering pump at max. pressure	<ul style="list-style-type: none"> <li>Hydraulic oil temperature: 55 – 65 °C.</li> <li>Engine oil temperature cooling circuit: in the limits</li> <li>Raised machine and working brakes applied in 2<sup>nd</sup> gear and total steering</li> </ul>		2600±50			Min. 2500			
	With equipment pump at max. pressure	<ul style="list-style-type: none"> <li>Hydraulic oil temperature: 55 – 65 °C.</li> <li>Engine oil temperature cooling circuit: in the limits</li> <li>Front bucket curled</li> </ul>		2550±50			Min. 2450			
Control valve	All controls (front bucket and backhoe)	 <p style="text-align: center;">RKZ03870</p>	mm	ℓ	a	b	ℓ	a	b	
				45	7	7	45	7	7	
Travel of levers and pedals	Front bucket tilt lever control	<ul style="list-style-type: none"> <li>Engine stopped</li> <li>At the centre of knob lever</li> <li>Valve reading at the end of working stroke</li> <li>Attachments on the ground</li> </ul>	Neutral → Raise Lower	mm	100			90 – 110		
	Front bucket control lever		Neutral → Dump Curled		100			90 – 110		
	Additional attachments control lever		Neutral → R.H. side L.H. side		100			75 – 125		
	Boom control lever		Neutral → Raise Lower		80			70 – 90		
	Arm control lever		Neutral → Opening Closing		80			70 – 90		
	Bucket control lever		Neutral → Opening Curled		80			70 – 90		
	Boom swing control lever		Neutral → Right Left		80			70 – 90		
	Outriggers control lever		Neutral → Up Down		50			40 – 60		
	Fuel control lever		Min. → Max.		220			200 – 400		
	Jig arm control pedal		Neutral → Out In		25			15 – 35		
	Side digging boom control pedal		Neutral → Right Left		25			15 – 35		
	Hammer control pedal		Neutral → — Max.		25			15 – 35		

● FOR MACHINE

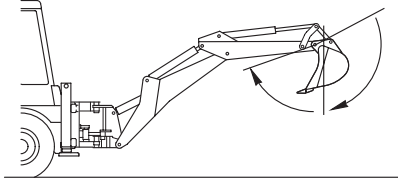
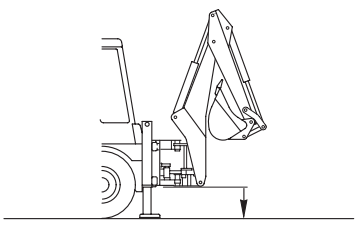
Machine model				WB70A-1	
Classi- fication	Check item	Test conditions	Unit	Standard value	Permissible value
Time lags	Work equipment	<b>Measuring posture</b>  D0401023 <ul style="list-style-type: none"> <li>● Engine speed: Min.</li> <li>● Oil temperature: 55 – 65°C</li> <li>● Put arm in horizontal position. Tilt back bucket cylinder and then extend it. Check the time passing between bucket stop at dead centre and the restart movement.</li> </ul>	sec.	0	Max. 2
		<b>Measuring posture</b>  D0401024 <ul style="list-style-type: none"> <li>● Engine speed: Min.</li> <li>● Oil temperature: 55 – 65°C</li> <li>● Boom, arm and bucket fully retracted and putted in machine centre position</li> <li>● Check the time necessary for outriggers to raise the machine from when they lean on level ground.</li> <li>★ Check each outrigger at a time.</li> </ul>		0	Max. 2

## ADJUSTING INCH PEDAL TRAVEL

1 - Loosen nut (1) and tight the end pedal travel bolt (2) of some turns.

- ★ Make sure that the inch valve control lever (3) returns at its total locking position.
- ★ To check the return in position of inch control lever (3), disconnect rod (4) and check that the distance between lever and pedal is within a play of 0.1–0.2 mm measured between valve lever and lever stopper.
- ★ At the end of adjusting reconnect the rod (4), and adjust the fork (7).

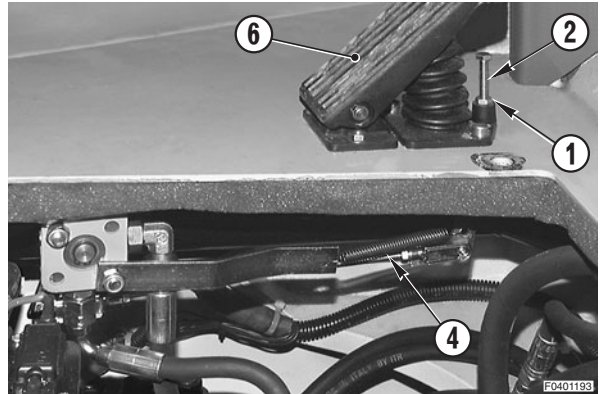

2 - Push control pedal (5) slowly until it reaches the end.

- ★ The end travel is given when the lever contacts the holder (6).

3 - Keeping the pedal position (5), adjust end travel bolt (2) near to pedal stopper.

4 - Release pedal, loosen end pedal travel bolt (2) of other 45° and lock in position with nut (1).

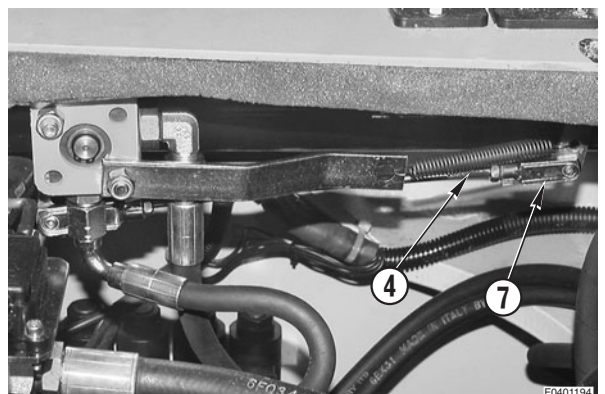
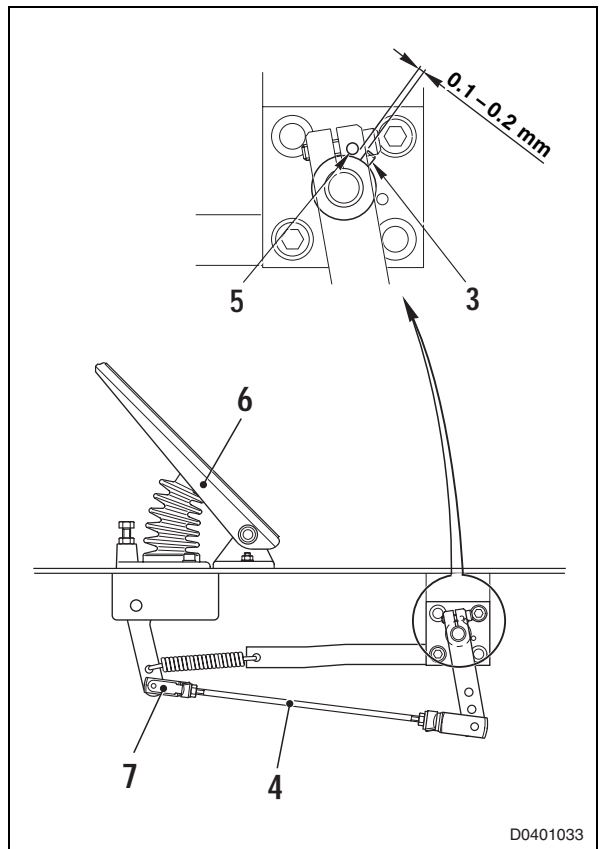

#### 4. Main and secondary valves setting

 For setting, prepare machine as per pressure testing.

- 1 - Loosen lock nut (1).
- 2 - Adjust pressure with adjusting screw (2).
  - To INCREASE pressure, rotate in CLOCKWISE direction.
  - To DECREASE pressure, rotate in COUNTERCLOCKWISE direction.
- 3 - Lock position with nut (1).

 Lock nut: 22 Nm

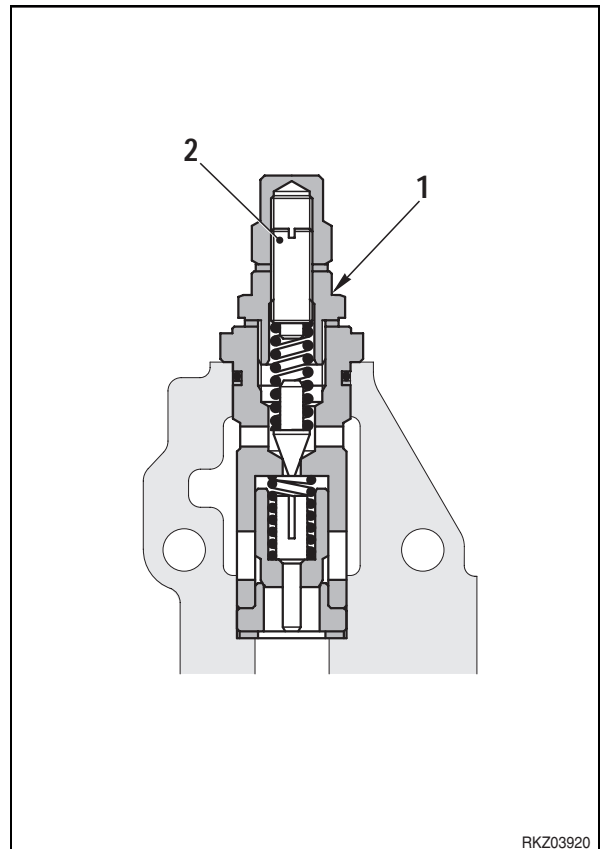

## TESTING PRIORITY VALVE OPERATION

### ★ Test condition:

- Engine: operating temperature
- Hydraulic oil: 55–60 °C
- Parking brakes: applied

### 1. Testing Load Sensing signal

- 1 - Connect gauge **E3** (250 bar) to priority valve (2) pressure port (1).
- 2 - Start the engine and bring it to idle speed of 2000 rpm.
- 3 - Check on gauge **E3** pressure value with stopped steering wheel.
- 4 - Start a slight steering and check that pressure increases.
- 5 - Continue the steering up to end of stroke and check that, forcing the steering wheel, pressure increases till normal value.
  - ★ Normal pressure:  $160 \pm 5 \text{ kg/cm}^2$
- ★ If turning the steering wheel the pressure shown by gauge does not change and stress on steering wheel necessary to carry out steering is high, check the priority valve (2).

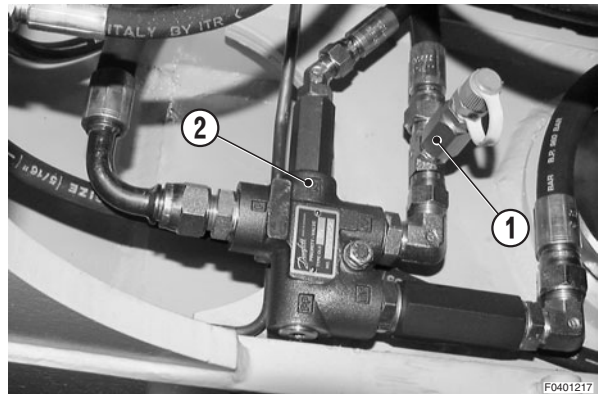
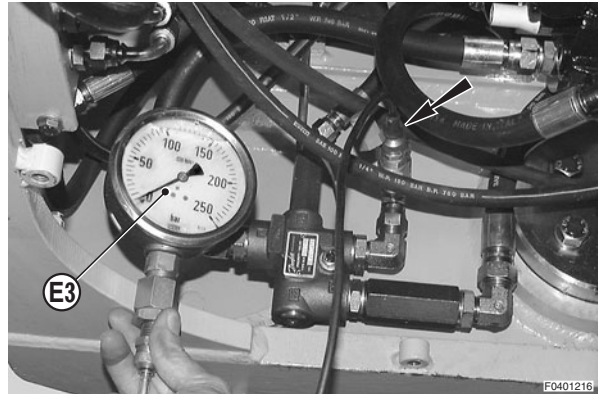

### 2. Testing priority valve operation

- 1 - Remove priority valve (2).  
(See «30. REMOVAL AND INSTALLATION»).
- 2 - Remove inlet plug «PP» (3) and check (pushing with a rod) that spool (4) moves freely for all possible travel.
- 3 - Check that inner nozzle (5) of spool is free.
- 4 - Reassemble priority valve (2).
- 5 - Start the engine and bleed Load Sensing circuit.  
(See «AIR BLEEDING OF LOAD SENSING CIRCUIT»).
- 6 - Carry out some steerings and, if failure remain, overhaul or replace orbit-roll valve.

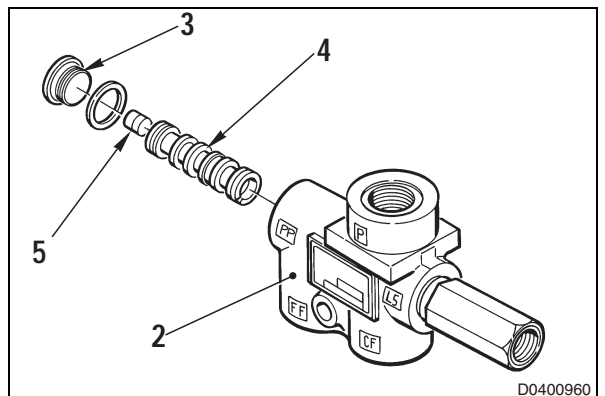

- 3 - Disconnect pipes (1) and (2) pipes from arm cylinder (3) and plug them to avoid impurity inlet.
  - ★ If safety valve is fitted, provide to removal.
- 4 - Plug arm cylinder hole on head side and fit a temporary pipe on base side to catch possible oil leakage.

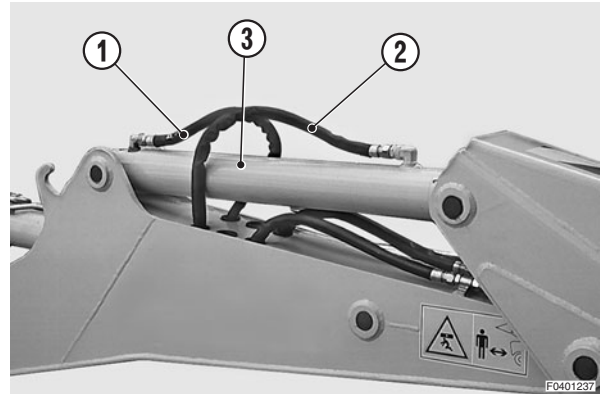

- 5 - Start the engine and raise the boom.
- 6 - Stop the engine and check the arm position for 5 minutes.
  - If arm has a lowering movement, drift is due to cylinder gaskets.
  - If arm has no movement, drift is due to control valve.

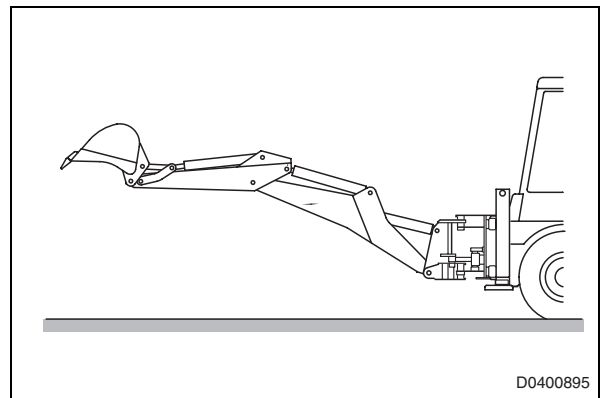

**3. Bucket testing**

- 1 - Set the machine with vertical arm and horizontal bucket leaned at level ground on the side. Put in the bucket a weight or fill it with earth.

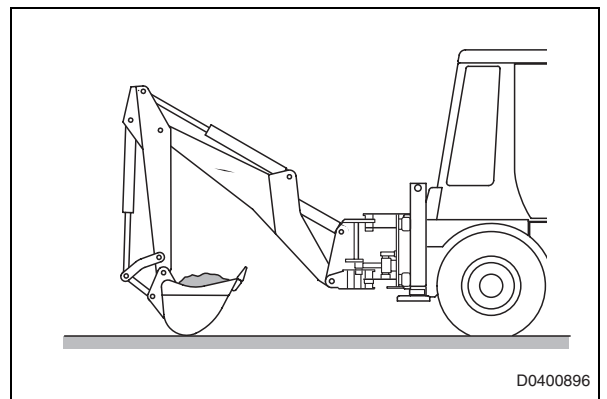

- 2 - Stop the engine and remove the remain hydraulic pressures.
- 3 - Disconnect bucket cylinders (3) pipes (1) and (2) and plug them to avoid impurity inlet.
- 4 - Plug bucket cylinder hole on base side and fit a temporary pipe on head side to catch possible oil leakage.

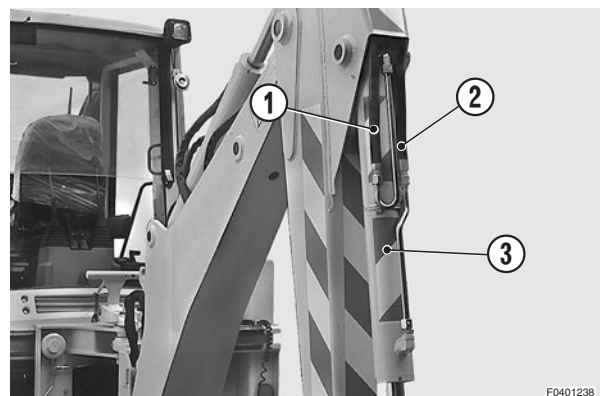

## SPECIAL TOOLS (For machine)

Nature of work	Symbol		Code	Description	Q.ty	Notes
Installation of fuel tank Installation of hydraulic tank	A	1	ATR201290	Tool	1	Tanks lifting
Disassembly and assembly piston pump	B	1	ATR501260	Plunger	1	Check ring disassembly
		2	ATR501270	Tool	1	Control shaft assembly
		3	ATR501280	Tool	1	Seal assembly
Assembly travel motor	C	1	ATR501290	Tool	1	Rotating unit assembly
		2	ATR501300	Tool	1	For central pin clearance checking
		3	ATR501310	Tool	1	Gasket, spacer, circlip assembly
Assembly of steering unit	D	1	ATR501090	Guide	1	Spool seal assembly
				Plunger		
				Fork		
		2	ATR501100	Fork	1	Control shaft check
		3	ATR501110	Plunger	1	Dust seal assembly
Disassembly and assembly transmission	E	1	ATR501320	Tool	1	Pinion lock
		2	ATR501330	Tool	1	Locking-unlocking pinion nut
Disassembly and assembly axles	F	1	1332	Tool	1	Disassembly and assembly rear axle bevel pinion
		2	0861	Tool	1	
		3	1330	Tool	1	Thrust bearing assembly in rear axle pinion bracket
		4	1725	Tool	1	Bevel pinion adjusting and seal assembly in rear axle
		5	1726	Tool	1	
		6	1326	Wrench	1	Bevel gear torque adjusting
		7	1314	Tool	1	Seal hub assembling
		8	1324	Tool	1	Arm seal assembly
		9	1319	Tool	1	Bearing assembly
Disassembly and assembly cylinders	G	1	ATR200620	Attachment	1	Cylinders disassembly - assembly
		2	ATR200740	Plunger ø 30	2	Cylinder bushings head and rod assembly. Cylinder and rod locking on ATR200620
			ATR200750	Plunger ø 35	2	
			ATR200760	Plunger ø 40	2	

## REMOVAL OF NOZZLE HOLDER

1 - Loosen clips (1) and (2) and remove high pressure pipes (3) and fuel recovery pipes (4). ※1

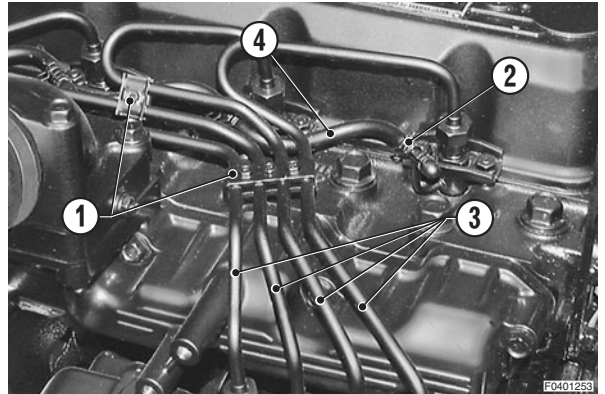

2 - Remove collar (6) lock nut (5) and remove nozzle holder (7), seat (8) and guard (9). ※2

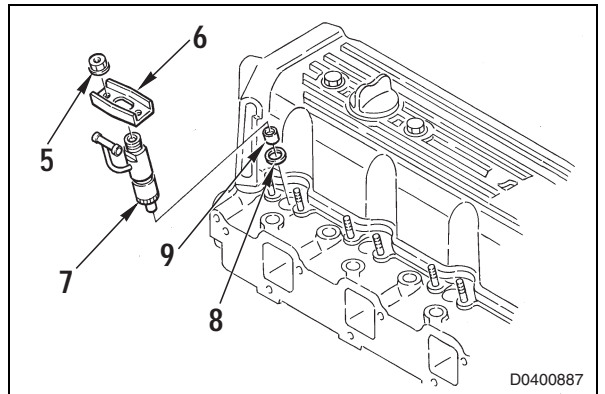

※2

## INSTALLATION OF NOZZLE HOLDER

- To install, reverse the removal procedure.

※1

 High pressure pipe fittings: 19.6 ~ 24.5 Nm

※2

 Collar lock nuts: 6.9 ~ 8.8 Nm

CLICK HERE TO **DOWNLOAD** THE COMPLETE MANUAL

- Thank you very much for reading the preview of the manual.
- You can download the complete manual from: [www.heydownloads.com](http://www.heydownloads.com) by clicking the link below



- Please note: If there is no response to CLICKING the link, please download this PDF first and then click on it.

CLICK HERE TO **DOWNLOAD** THE COMPLETE MANUAL

7 - Disconnect pipes (11) from steering unit (10).

- ★ Mark pipes to avoid exchanges when they will be reconnected.
- ★ Plug pipes and connectors to avoid impurity entry.

※2

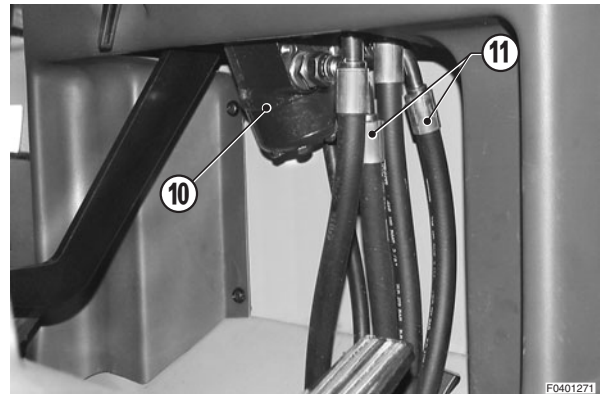

8 - Disconnect pipes (12) from inch valve (13).

- ★ Plug pipes and connectors to avoid impurity entry.

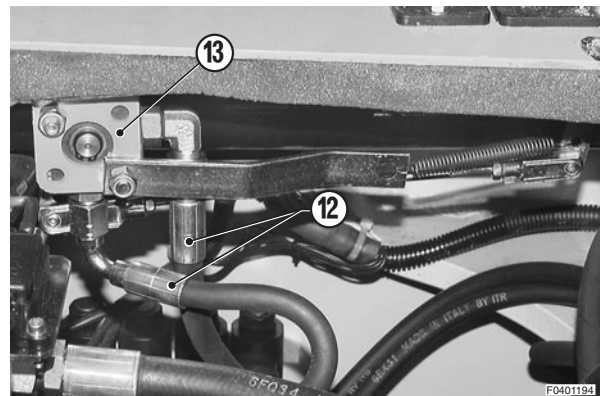

9 - Remove instrument panel (15) mounting bolts (14), handle (16) and relative pin and front hood (18) mounting bolts (17).

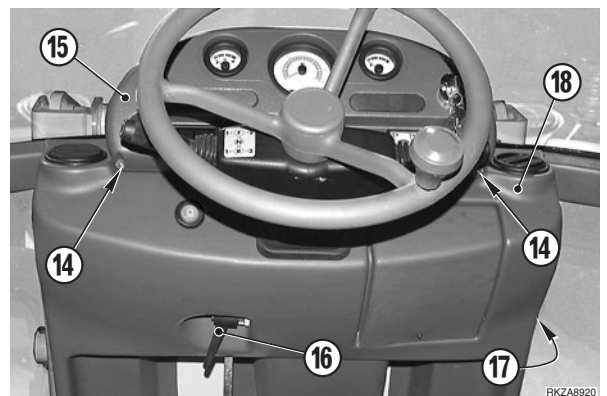

10 - Remove instrument panel (15) and loosen central upper bolts (19) and front hood (18) mounting side bolts (20).

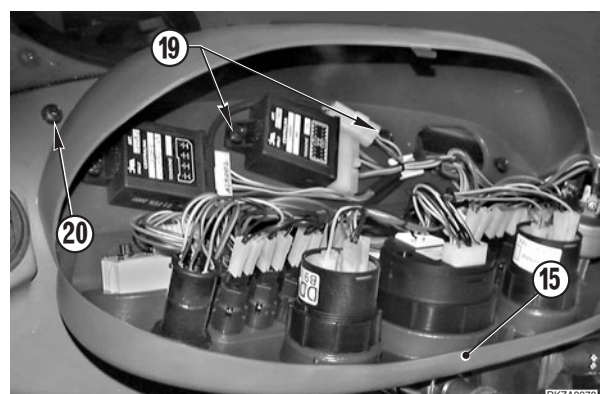

## DISASSEMBLY OF PISTON PUMP

- 1 - Loosen boosting pump (2) bolts (1) (No. 4).  
Remove boosting pump (2).

★ Before disassembling boosting pump (2), mark position between pump and valve body (3).

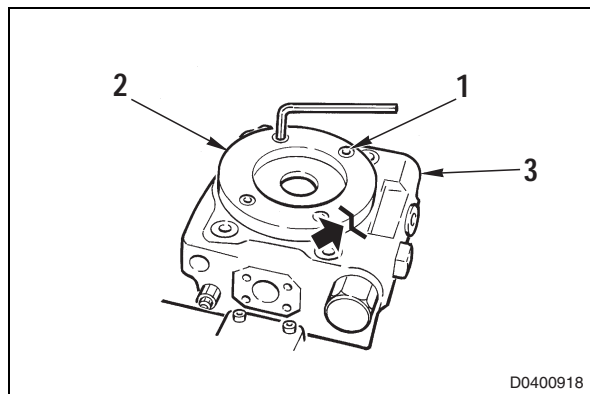

- 2 - Mark the adjusting screw (4) position.  
Loosen screw (4) of 45° in clockwise direction.

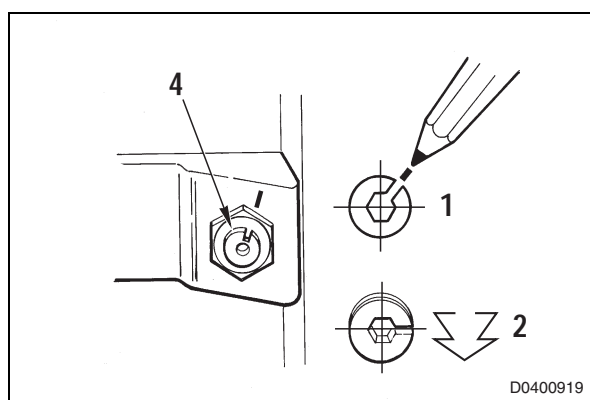

- 3 - Loosen the bolts (5) (No. 4) and remove valves body (3) using some levers.

★ Be careful not to damage the machined surfaces.

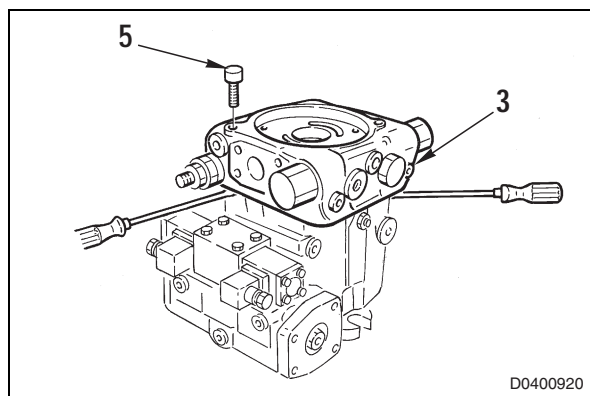

- 4 - Remove the valve plate (6) from valves body (3).

★ Be careful to assembly position.

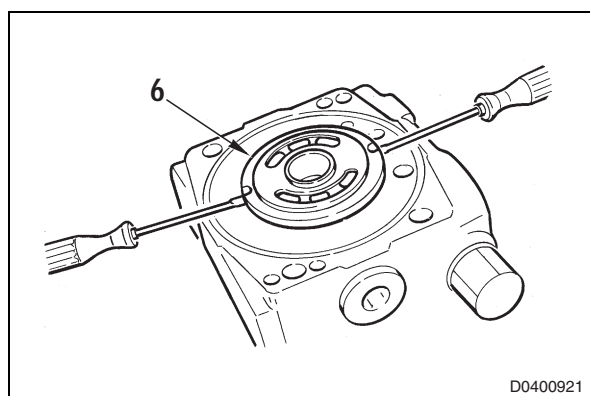

17 - Fit initial adjusting valve (42).

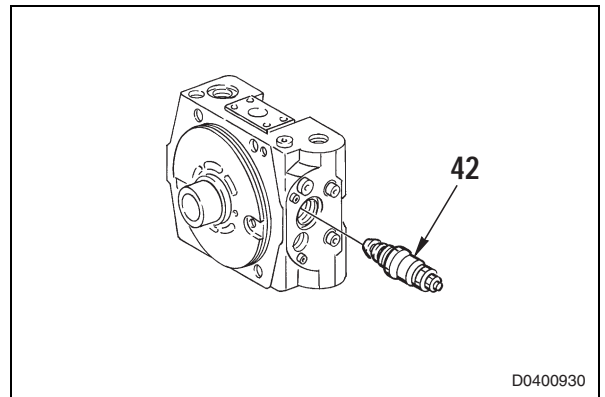

D0400930

18 - Fit into valve body the flow selection valve seat (41), flow selection valve (40), bushing (39), piston (38), plunger (37), adjusting pin (36), spring (35), adjusting pin (34) and nut (33).

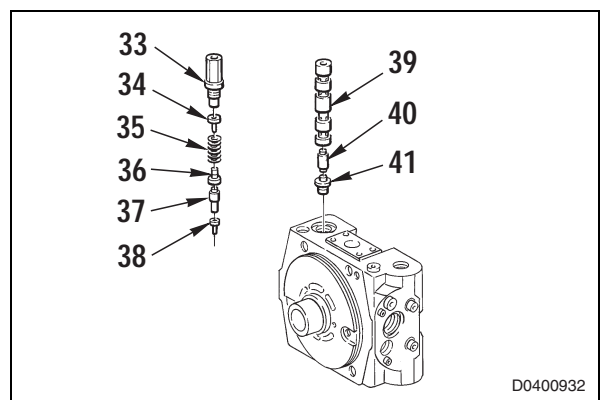

D0400932

19 - Fit the safety valves (32) (No. 2).

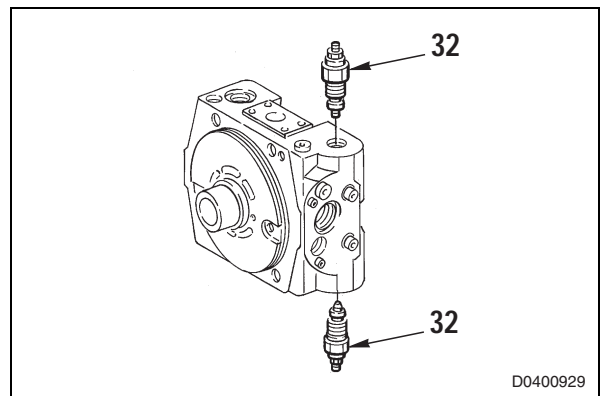

D0400929

20 - Fit valve body (3) on pump body and tighten bolts (5) (No. 4).

★ Align marks carried out before disassembly on valve plate position adjusting screw.

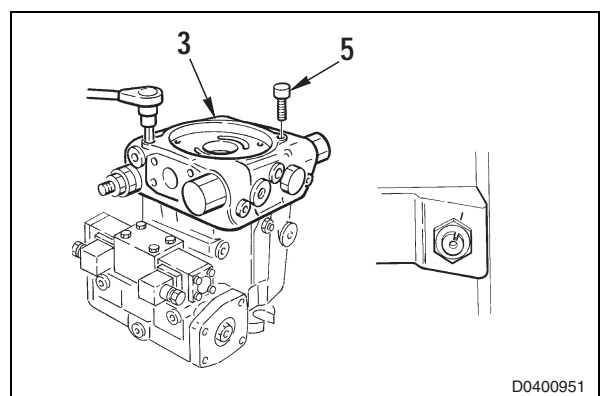

D0400951

- 9 - Assemble and set tool **C2** on motor case (11).  
Check and bring to zero dial gauge when knob has been rotated in counterclockwise direction till end of stroke.

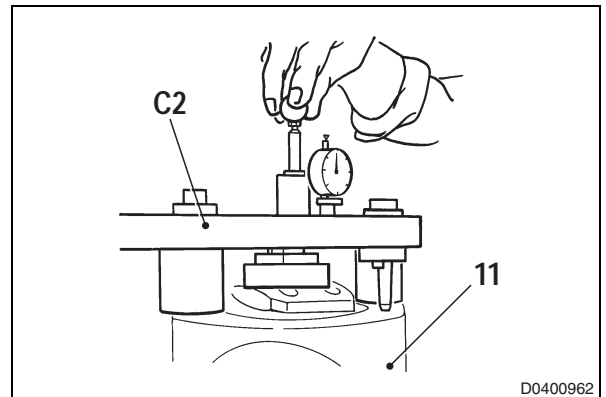

- 10 - Rotate the knob for 4 turns in clockwise direction and make sure with a caliper that the dial gauge has a clearance of 2 mm and that pointer is in zero position.  
★ This is the starting zero for checking.

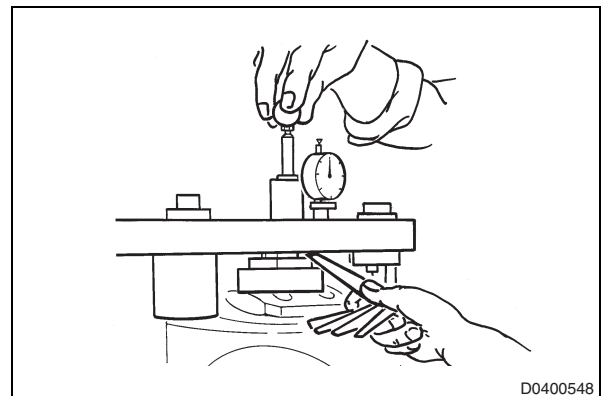

- 11 - Rotate the knob in clockwise direction till end of stroke and check the central pin (30) clearance value that corresponds to dial gauge indicated value.  
★ If central pin clearance is not within the tolerance, replace springs guide plate (31).

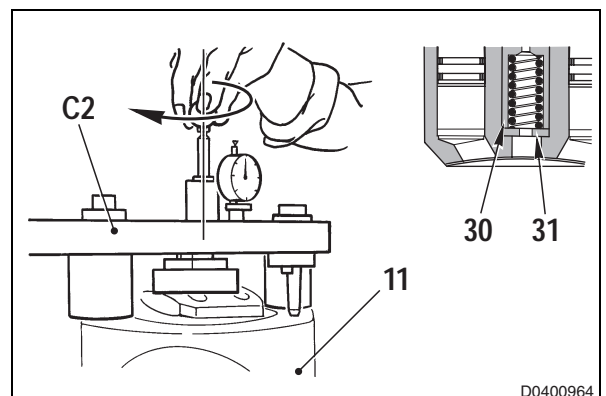

- 12 - Remove tool **C2**.

## REMOVAL OF TRANSMISSION-REVERSE, DIRECTION INDICATOR AND HEADLIGHT DIPPER BEAM CONTROL GROUP

**⚠** Lower completely the work attachment until leaning on level ground and stop the engine.

**⚠** Disconnect cable from accumulator negative terminal (-).

- 1 - Remove steering wheel central cap (1).
- 2 - Remove the retaining nut (2) and relative washer; remove the steering wheel (3).

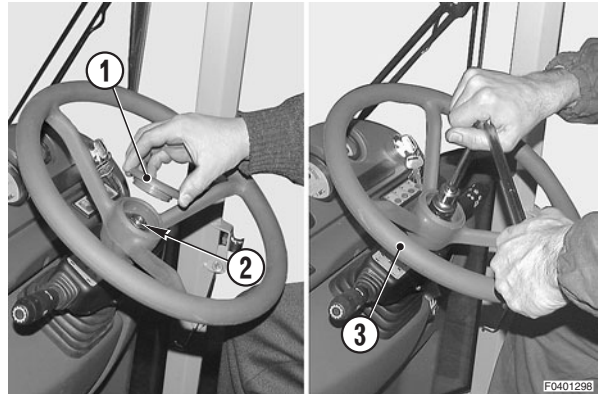

- 3 - Remove the connection bolts (4) (No. 4) of switches units (5) and (6).

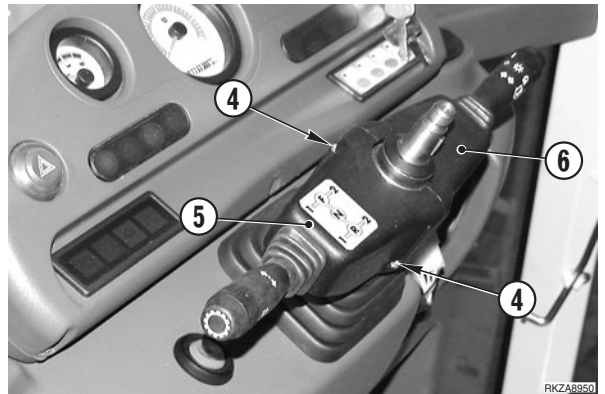

- 4 - Remove the right half clamp (7). ※ 1
- 5 - Open the door of gear case and disconnect the switches connectors (8) and (9).
- 6 - Remove the switches units (5) and (6) complete with guard cowling (10).

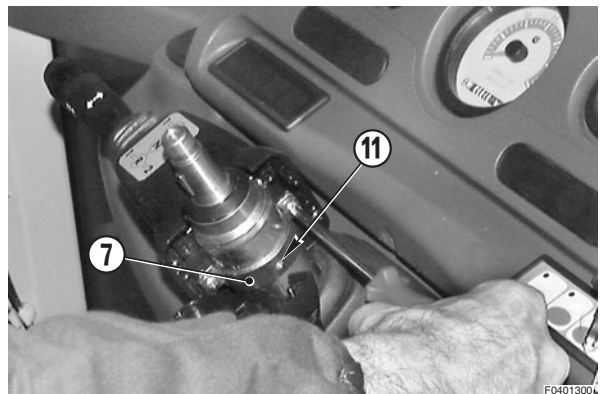

## INSTALLATION

- To install, reverse the removal procedure.

※ 2

- ★ Check that dowel (11) is fully connected into the steering column and that transmission-reverse gear control unit is perfectly sticking to the steering column.

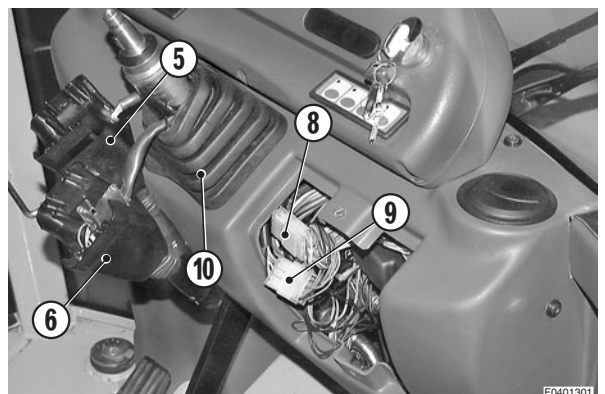

9 - Assemble the thrust bearing according to scheme shown at point 10.

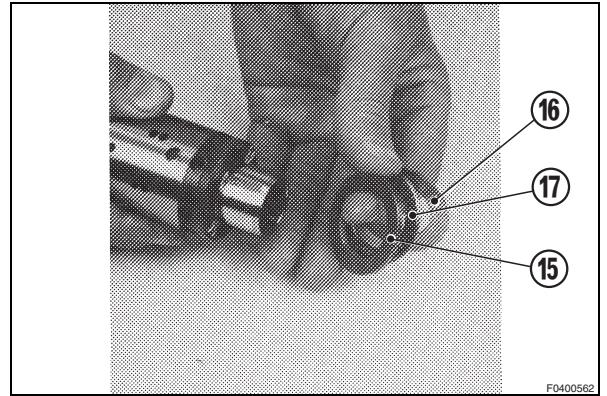

10 - Scheme of bearing assembly.

- 15 - Outer ring
- 16 - Inner ring
- 17 - Needle bearing
- 19 - Bushing
- 20 - Spool

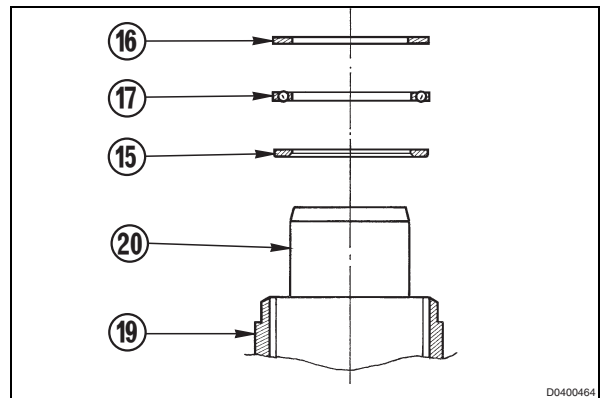

11 - Arrange the steering unit case (14) with horizontal hole. Insert into the bushing/spool unit hole the tool **D1** guide.

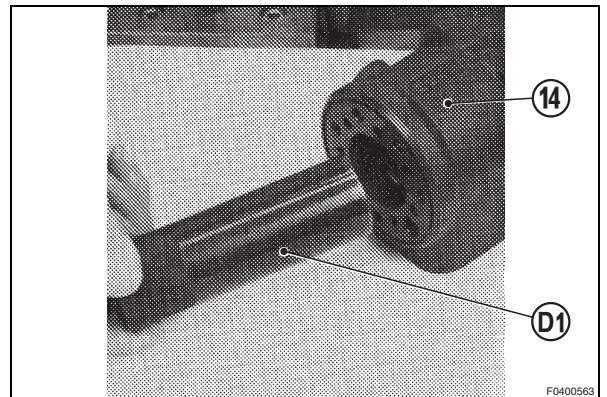

12 - Lubricate the seal (23a) and O-ring (23b) and assemble them on tool **D1** strut.

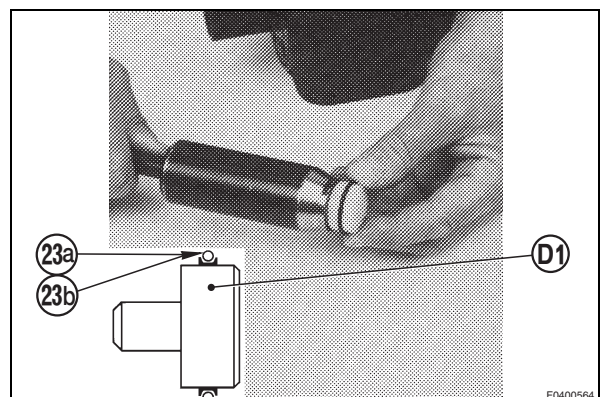

## REMOVAL OF FRONT EQUIPMENT CONTROL VALVE

**⚠** Lower completely the work attachments until leaning on level ground, stop the engine and remove the starting key.

**⚠** Release completely the residual pressure from all circuits. (For details, see «20. TESTING AND ADJUSTMENTS»).

1 - Remove the knob (1), the rubber guard (2), the stud (3) and the front control bucket hood (4).

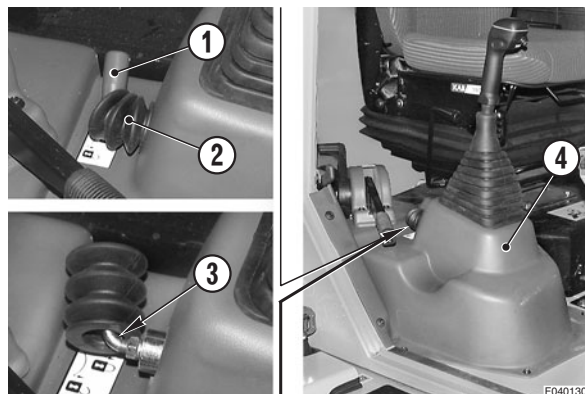

2 - Disconnect from control valve all pipes, of pump delivery and exhaust pipes.

★ Mark pipes to avoid position exchange when they will be reconnected.

3 - Disconnect the control rods (5) from spools.

4 - Remove the control valve mounting bolts (6) (No. 3).

5 - Remove the control valve (7).

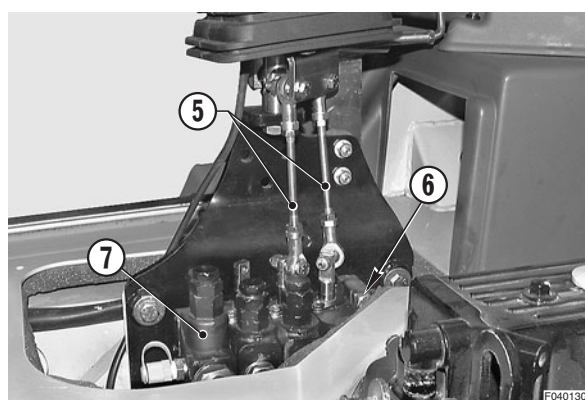

## INSTALLATION OF FRONT EQUIPMENT CONTROL VALVE

• To install, reverse the removal procedure.

1 - Start the engine to allow oil circulation and check that there are no leaks.

2 - Bleed the air from all circuits. (For details, see «20. TESTING AND ADJUSTMENTS»).

3 - Stop the engine and check the oil level in the tank.

- 3 - Take out the bearing (36) and remove the bolts (37) (No. 12).  
Remove the cover (38), the pinion gears (39) and the thrust washer (40).

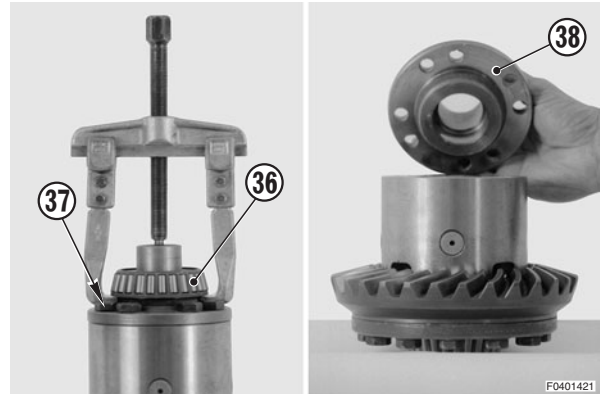

- 4 - Insert completely the dowels (41) (No. 3) in the shafts (42) and (43). Remove shafts (42) and (43), spider (44), sun gears (45), thrust washers (48) and second pinion gear (39) complete with shim (40).  
Loosen the bolts (46) and remove the ring bevel gear (47).

★ Replace the bolts (46) at each disassembly.

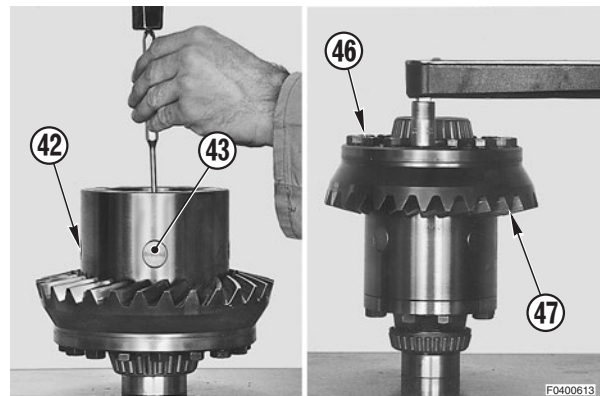

- 2 - Introduce pistons assembly (22) (No. 3 each side) into the intermediate cover (21).  
 Raise the pressure into the brake circuit for about ten minutes with compressed air at 0.5 – 1 bar.  
 Repeat the test for the other side.

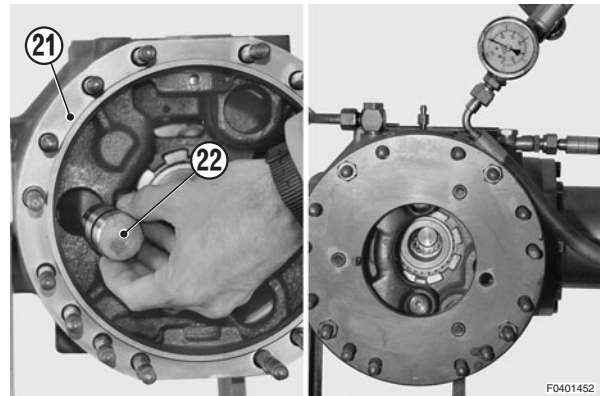

- 3 - Introduce brake discs (19) and (20) into their seat.  
 ★ Make sure that lubricating holes are all aligned.  
 ★ Make sure that discs are assembled in the right order.

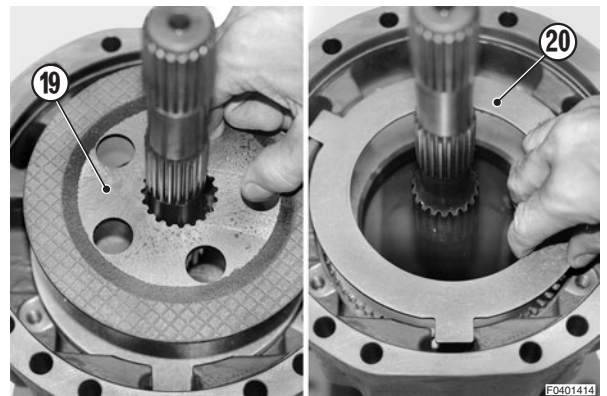

- 4 - Introduce thrust plate (18), the spring (69), the adjusting bolts (17) complete with O-ring.  
 Tight the adjusting screws (17).

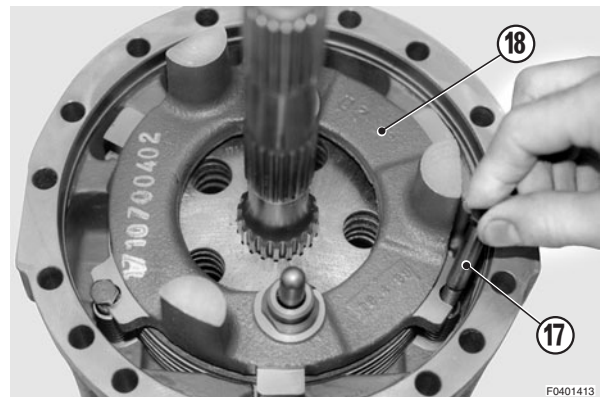

- 5 - Assemble the axle housings (15) on differential case and lock the nuts (14).  
 Adjust brake discs clearance, loosening the adjusting bolts (17) of 1/2 turn.  
 Tight the lock nuts (16) (No. 3 each side).

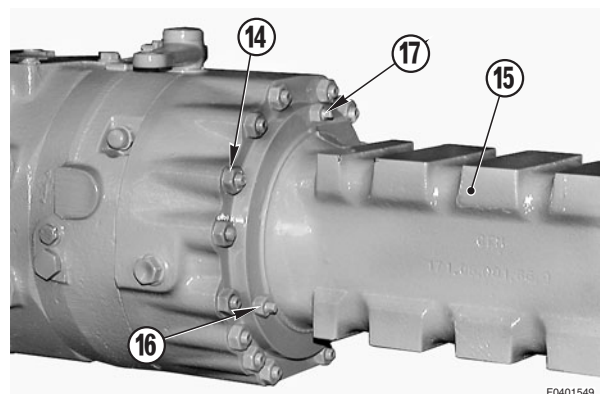

4 - Assemble into the housing (25) and into the cover (24) the thrust washers of taper bearing (41) and (21).

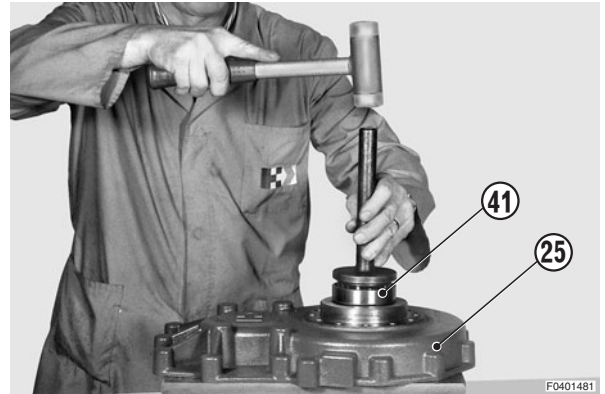

5 - Assemble taper bearing inner ring (41) and rotate it to carry out a settling.  
Keeping ring stopped into its seat, measure the dimension «A» between bearing inner ring and surface of axle case.



6 - Mark the measure «A» taken on the housing.



7 - Using a press, assemble on pinion (15) the bearing (41) inner ring.

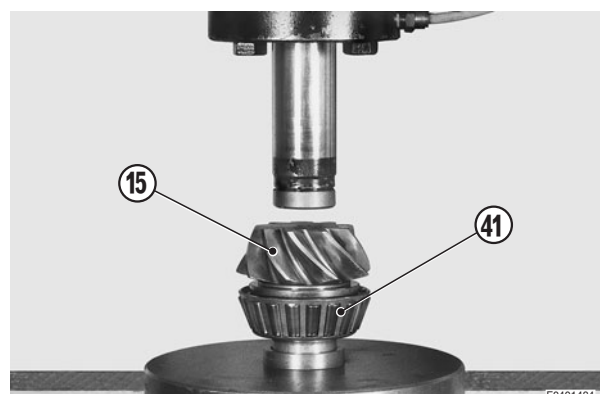

10 - Disconnect the ground cable (7).

11 - Remove the flange (9) mounting bolts (8); remove the flange (9) and O-ring (10). ※3

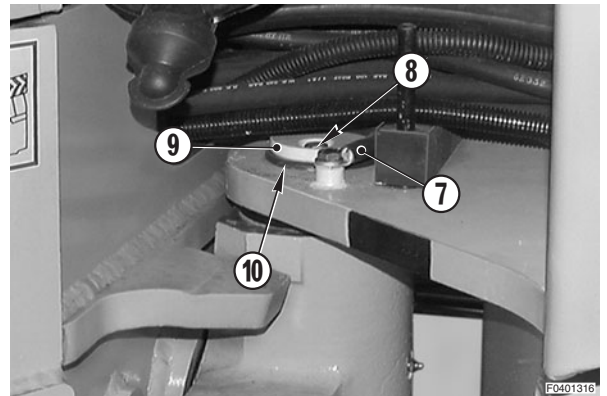

12 - Remove the lock nuts (11) and pin mounting bolts. ※4

13 - Remove the joint pin (12).

- ★ If pin removal is difficult, operate on jacks or lift front frame until finding the ideal alignment for an easy removal of joint pin (12).

14 - Using a lever and the lifter, divide the front frame from the rear one, removing it of about 50 cm.



## INSTALLATION OF FRAMES JOINT PIN

- To install, reverse the removal procedure.
- ★ Replace all O-rings installed to keep the lubricating grease.

※1

1 - Before to use the machine, proceed to joint pin lubrication.

※2

- ★ Bleed the travel and the hydraulic circuits.

- ★ **Only for bucket cylinder control**
- a - Assemble the first retaining ring (23) of gasket (24).
- b - Assemble the anti-extrusion ring (25).
- c - Assemble the gasket (24).
- d - Assemble the second anti-extrusion ring (25).
- e - Assemble the second retaining ring (23) of gasket (24).

6 - Assemble the piston rod nut (6) and lock it with a dynamometric wrench.

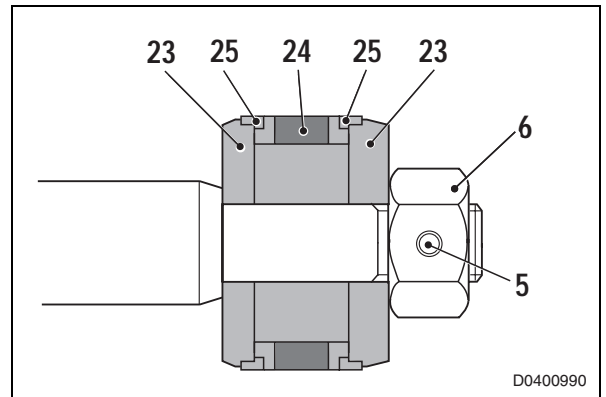

Unit: kgm

Cylinder	Arm lift	Bucket control	Steering
Tightening torque	85 – 90	100 – 105	60 – 65

7 - **Only for bucket cylinder control:** insert the dowel pin (5) which lock the nut position (6).

#### 4. CYLINDER ASSEMBLY

- 1 - Assemble tools **G2** on attachment **G1**.
- 2 - Set the bushing (21) and assemble it into the cylinder (1) eye.
  - ★ Leave the cylinder in this position for the next assembly.

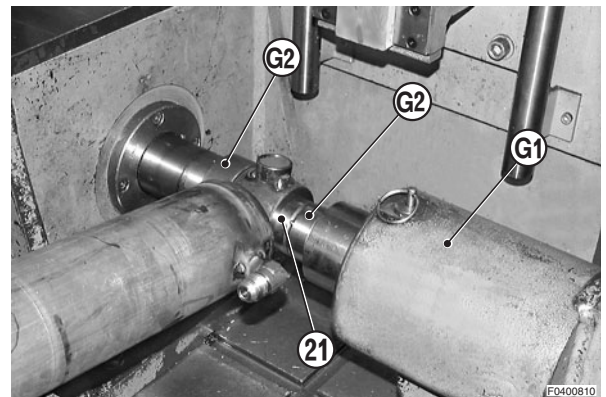

3 - Lubricate the thread and the first portion of cylinder (1).

 Cylinder: ASL800050

4 - Assemble the two half part of tool **G7** fitting to diameter at cylinder (1) entrance.

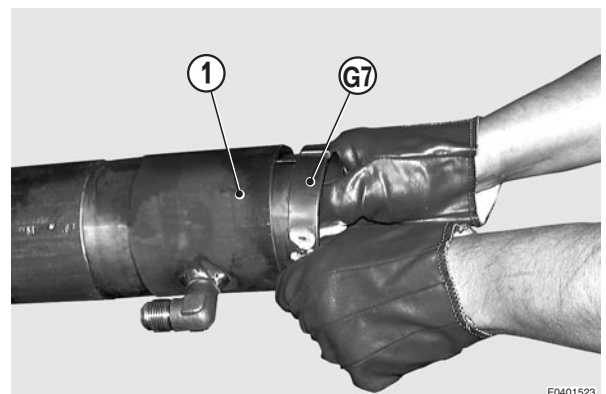

## REMOVAL OF BACKHOE ARM CYLINDER

**!** Extended the arm (1) and extend the bucket (2) completely; lower the boom (3) until leaning the joint between boom and arm on a stand (A) high about 90 cm and arm end on a block (B) high about 10 cm. Rest the bucket teeth against the ground level.

1 - Stop the engine and release the cylinder pressures moving control lever several times.

2 - Sling the cylinder (4).

3 - Remove the bolt (5) and the pin (6). ※ 1 ※ 2

4 - Start the engine and retract the piston (7).

★ Secure the piston (7) total return position fastening the rod eye with iron wire.

5 - Stop the engine and release the residual hydraulic pressures. (For details, see «20. TESTING AND ADJUSTMENTS»).

6 - Disconnect the hoses (8) and (9) and plug them to avoid impurity entry.

7 - Remove the bolt and the pin (10). ※ 1 ※ 2

8 - Remove the cylinder (4).

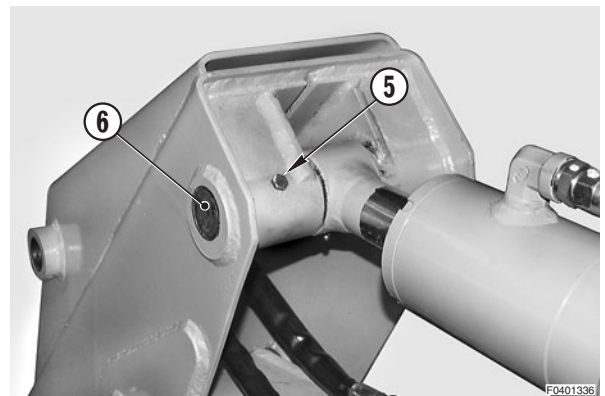
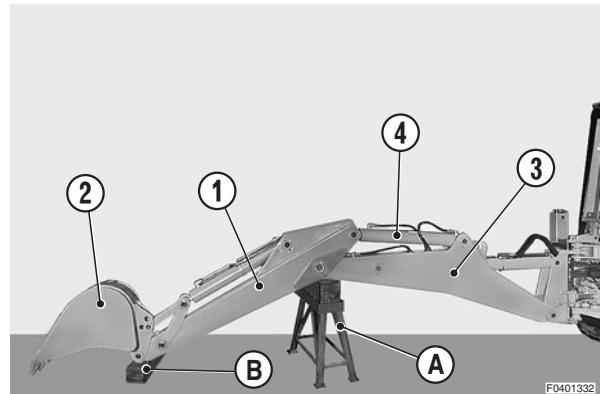

## INSTALLATION OF BACKHOE BOOM CYLINDER

• To install, reverse the removal procedure.

※ 1

**!** When aligning the positions between hole and pin, run the engine at idling. Do not introduce hand fingers in the holes to check the alignment.

※ 2

 Bushings inside: ASL800050

1 - Start the engine and bleed the air from cylinders. (For details, see «20. TESTING AND ADJUSTMENTS»).

★ After the air bleeding, check the oil level in the tank.

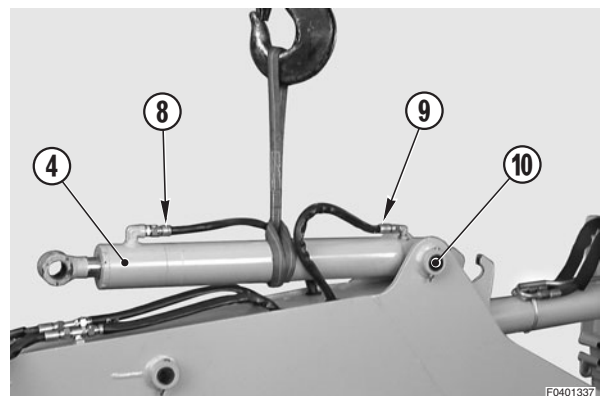

- 5 - Assemble the piston rod unit (6) on attachment **L1** and raise the movable side until end of stroke.
- 6 - Set the cylinder (1) in vertical position and drive the piston into the tool **L8**.
- 7 - Lower the attachment supporting the piston rod (6) to adjust the piston into the tool **L8**.
- 8 - Wrap first guide ring (25) on piston and insert a part of piston into the tool **L8**, wrap the second guide ring (25) and insert the piston totally.

**!** Carry out the piston introduction slowly to calibrate the guide ring (25) without to overheat them.

- 9 - Remove the tool **L8** from cylinder and then lower furtherly the attachment **L1** until approaching head (4) and rod eye to cylinder.
- 10 - Bring the cylinder (1) in the head (4) screw position.
- 11 - Insert the head into the cylinder and screw it manually for some turn.
- 12 - Apply the special wrench **L3** and screw completely the head (4).

 Nm Head: 95 – 100 kgm

- 13 - **For side digging boom cylinder only:** tighten the ring nut (5).

 Nm Ring nut: 50 kgm

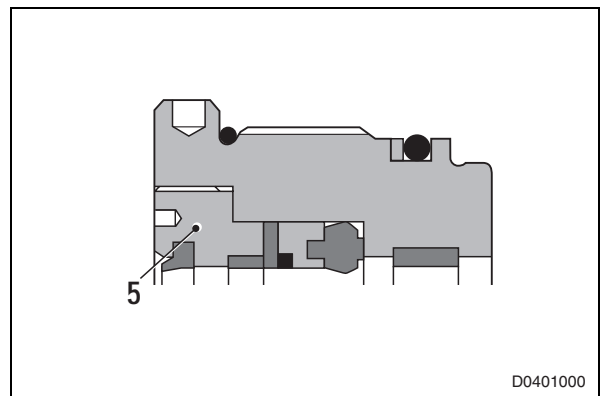
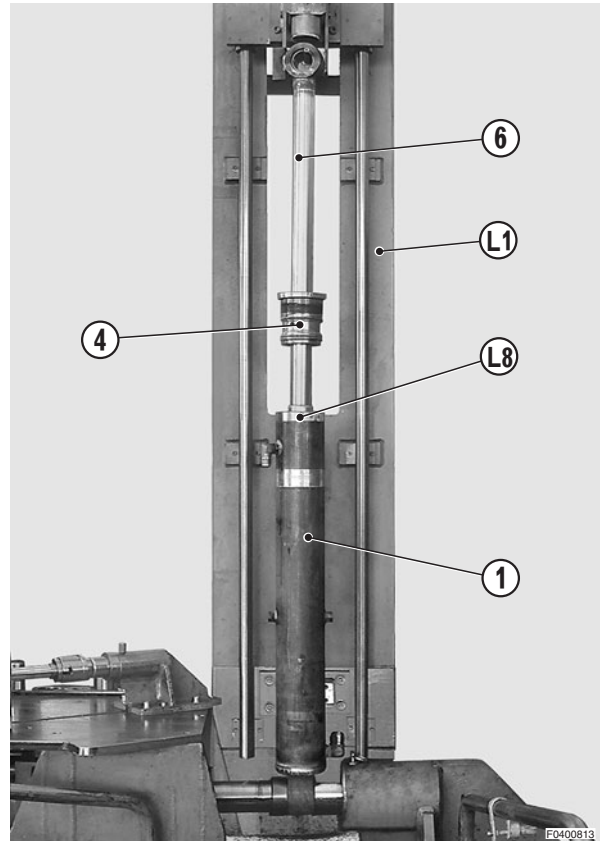

**GROUP**

**40**

# DIFFERENTIAL LOCKING

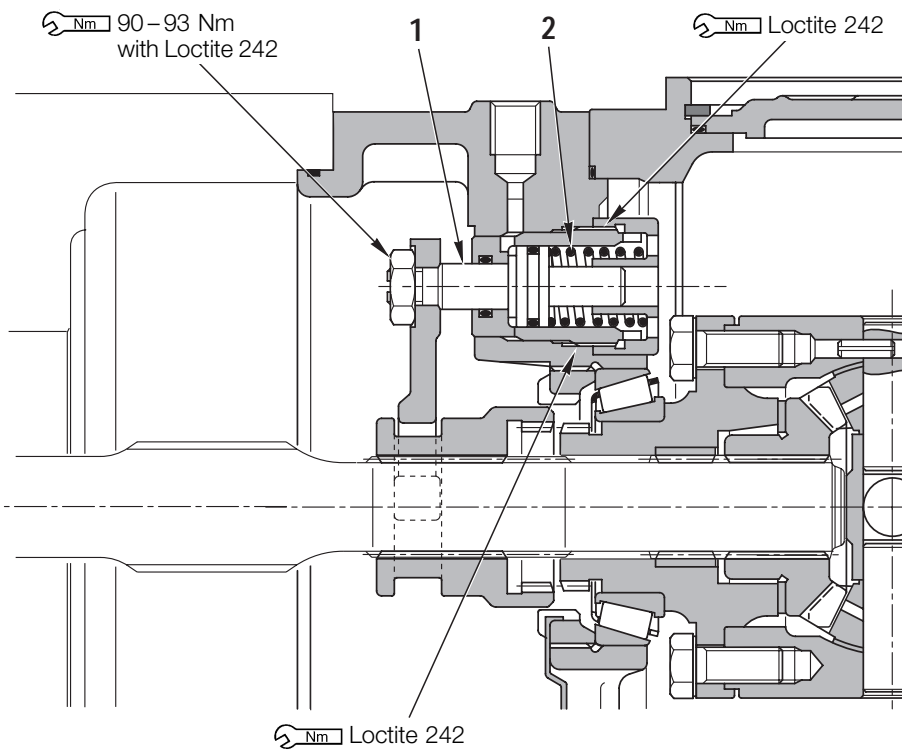

D0400762

Unit: mm

No.	Check item	Criteria					Remedy
		Standard size			Repair limit		
		Free length	Installed length	Installed load	Free length	Installed load	
1	Piston stroke	10					-
2	Piston returning spring	40.5	29	18.3±1	-		Replace if damaged or deformed

# 6-SPOOL CONTROL VALVE

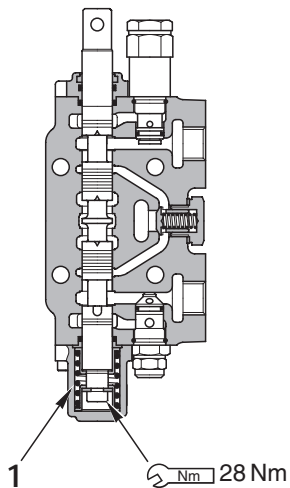
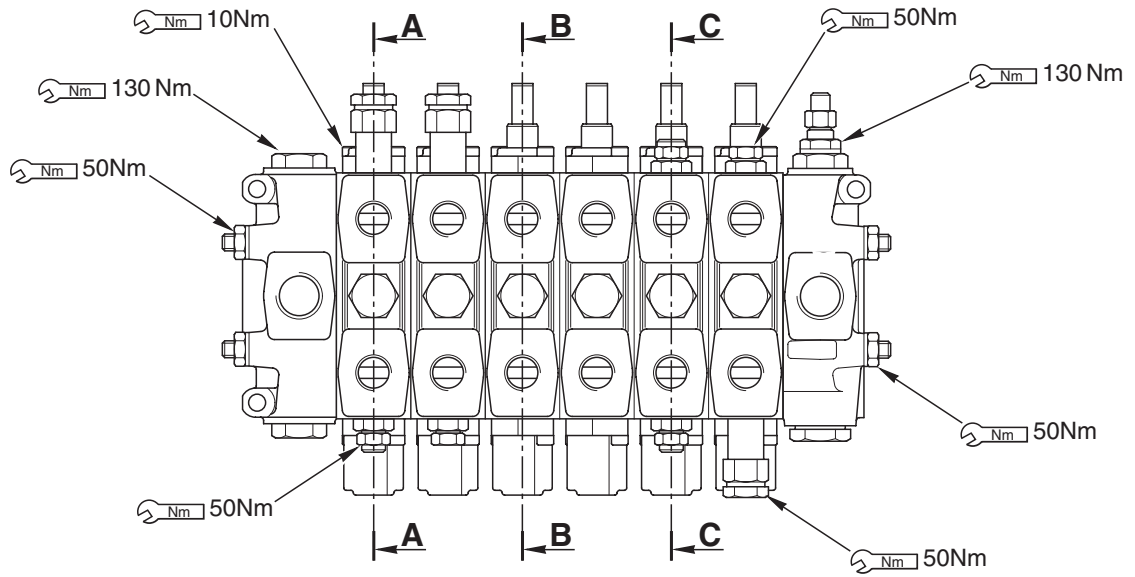

**Section A - A**

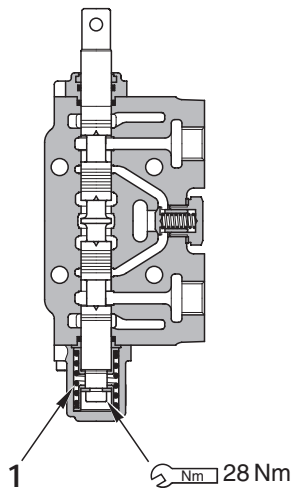

**Section B - B**

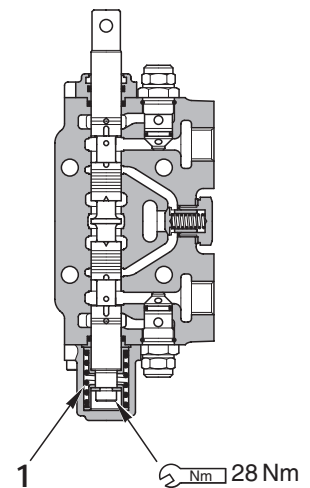

**Section C - C**

RKZ03940

Unit: mm

No.	Check item	Criteria					Remedy
		Standard value			Repair limit		
		Free length	Installed length	Installed load	Free length	Installed load	
1	Spool return spring	60	35	108.9	-	-	Replace if damaged or deformed

CLICK HERE TO **DOWNLOAD** THE COMPLETE MANUAL

- Thank you very much for reading the preview of the manual.
- You can download the complete manual from: [www.heydownloads.com](http://www.heydownloads.com) by clicking the link below



- Please note: If there is no response to CLICKING the link, please download this PDF first and then click on it.

CLICK HERE TO **DOWNLOAD** THE COMPLETE MANUAL