

Shop Manual

AVANCE **PC300LL-6** **LOGGING EXCAVATOR**

SERIAL NUMBERS **PC300LL-6** **A84001** and UP

This material is proprietary to Komatsu America International Company and is not to be reproduced, used, or disclosed except in accordance with written authorization from Komatsu America International Company.

It is our policy to improve our products whenever it is possible and practical to do so. We reserve the right to make changes or add improvements at any time without incurring any obligation to install such changes on products sold previously.

Due to this continuous program of research and development, periodic revisions may be made to this publication. It is recommended that customers contact their distributor for information on the latest revision.

CLICK HERE TO **DOWNLOAD** THE COMPLETE MANUAL

- Thank you very much for reading the preview of the manual.
- You can download the complete manual from: www.heydownloads.com by clicking the link below



- Please note: If there is no response to CLICKING the link, please download this PDF first and then click on it.

CLICK HERE TO **DOWNLOAD** THE COMPLETE MANUAL

Category	Code	Part No.	Quantity	Container	Main applications, features
Gasket sealant	LG-4	790-129-9020	200 g	Tube	<ul style="list-style-type: none"> ● Features: Resistance to water, oil ● Used as sealant for flange surface, thread. ● Also possible to use as sealant for flanges with large clearance. ● Used as sealant for mating surfaces of final drive case, transmission case.
	LG-5	790-129-9080	1 kg	Polyethylene container	<ul style="list-style-type: none"> ● Used as sealant for various threads, pipe joints, flanges. ● Used as sealant for tapered plugs, elbows, nipples of hydraulic piping.
	LG-6	09940-00011	250 g	Tube	<ul style="list-style-type: none"> ● Features: Silicon based, resistant to heat, cold. ● Used as sealant for flange surface, thread. ● Used as sealant for oil pan, final drive case, etc.
	LG-7	09920-00150	150 g	Tube	<ul style="list-style-type: none"> ● Features: Silicon based, quick hardening type. ● Used as sealant for flywheel housing, intake manifold, oil pan, thermostat housing, etc.
	Three bond 1211	790-129-9090	100 g	Tube	<ul style="list-style-type: none"> ● Used as heat-resisting sealant for repairing engines.
Molybdenum disulphide lubricant	LM-G	09940-00051	60 g	Can	<ul style="list-style-type: none"> ● Used as lubricant for sliding parts (to prevent squeaking).
	LM-P	09940-00040	200 g	Tube	<ul style="list-style-type: none"> ● Used to prevent seizure or scuffing of the thread when press fitting or shrink fitting. ● Used as lubricant for linkage, bearings, etc.
Grease	G2-LI	SYG2-400LI SYG2-350LI SYG2-400LI-A SYG2-160LI SYGA160CNLI	Various	Various	<ul style="list-style-type: none"> ● General purpose type
	G2-CA	SYG2-400CA SYG2-350CA SYG2-400CA-A SYG2-160CA SYG2-160CNCA	Various	Various	<ul style="list-style-type: none"> ● Used for normal temperature, light load bearing at places in contact with water or steam.
	Molybdenum disulphide lubricant	SYG2-400M	400 g (10 per case)	Belows type	<ul style="list-style-type: none"> ● Used for places with heavy load.

Liter to U.S. Gallon

1 L = 0.2642 U.S. Gal

	0	1	2	3	4	5	6	7	8	9
0	0	0.264	0.528	0.793	1.057	1.321	1.585	1.849	2.113	2.378
10	2.642	2.906	3.170	3.434	3.698	3.963	4.227	4.491	4.755	5.019
20	5.283	5.548	5.812	6.076	6.340	6.604	6.869	7.133	7.397	7.661
30	7.925	8.189	8.454	8.718	8.982	9.246	9.510	9.774	10.039	10.303
40	10.567	10.831	11.095	11.359	11.624	11.888	12.152	12.416	12.680	12.944
50	13.209	13.473	13.737	14.001	14.265	14.529	14.795	15.058	15.322	15.586
60	15.850	16.115	16.379	16.643	16.907	17.171	17.435	17.700	17.964	18.228
70	18.492	18.756	19.020	19.285	19.549	19.813	20.077	20.341	20.605	20.870
80	21.134	21.398	21.662	21.926	22.190	22.455	22.719	22.983	23.247	23.511
90	23.775	24.040	24.304	24.568	24.832	25.096	25.361	25.625	25.889	26.153

Liter to U.K. Gallon

1 L = 0.21997 U.K. Gal

	0	1	2	3	4	5	6	7	8	9
0	0	0.220	0.440	0.660	0.880	1.100	1.320	1.540	1.760	1.980
10	2.200	2.420	2.640	2.860	3.080	3.300	3.520	3.740	3.950	4.179
20	4.399	4.619	4.839	5.059	5.279	5.499	5.719	5.939	6.159	6.379
30	6.599	6.819	7.039	7.259	7.479	7.699	7.919	8.139	8.359	8.579
40	8.799	9.019	9.239	9.459	9.679	9.899	10.119	10.339	10.559	10.778
50	10.998	11.281	11.438	11.658	11.878	12.098	12.318	12.528	12.758	12.978
60	13.198	13.418	13.638	13.858	14.078	14.298	14.518	14.738	14.958	15.178
70	15.398	15.618	15.838	16.058	16.278	16.498	16.718	16.938	17.158	17.378
80	17.598	17.818	18.037	18.257	18.477	18.697	18.917	19.137	19.357	19.577
90	19.797	20.017	20.237	20.457	20.677	20.897	21.117	21.337	21.557	21.777

10 **STRUCTURE AND FUNCTION**

SWING CIRCLE	10-2
SWING MACHINERY	10-3
TRACK FRAME • RECOIL SPRING	10-4
SWING MOTOR	10-5
KMF160ABE-3	10-5
SUCTION-SAFETY VALVE	10-7
SWING BRAKE	10-8
CAB RISER AND RELATED PARTS	10-9

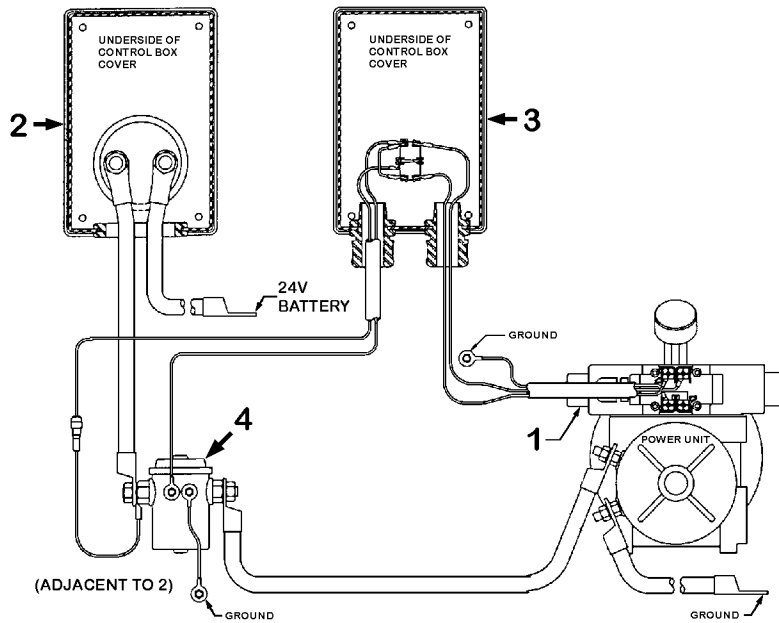
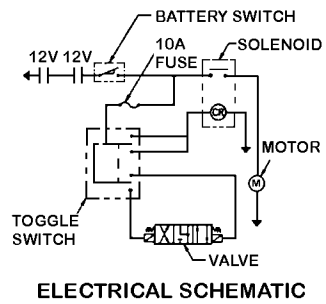
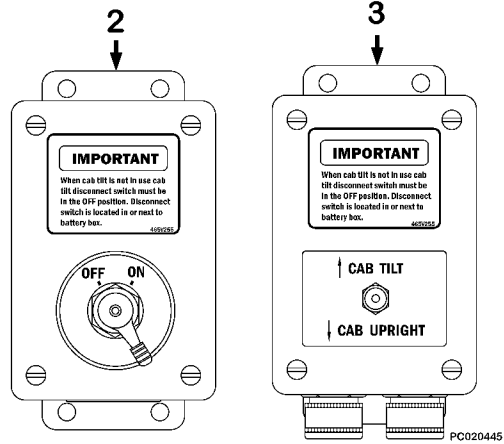
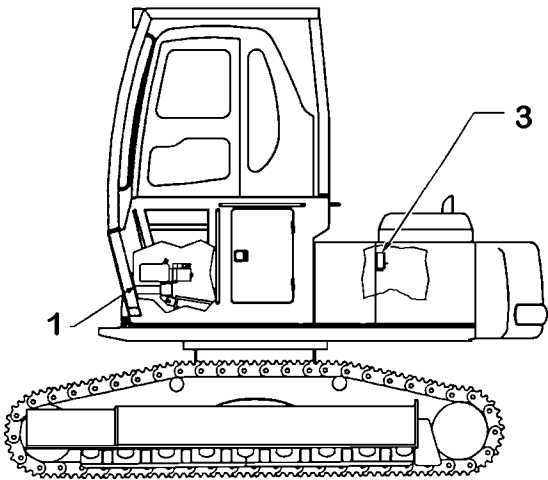
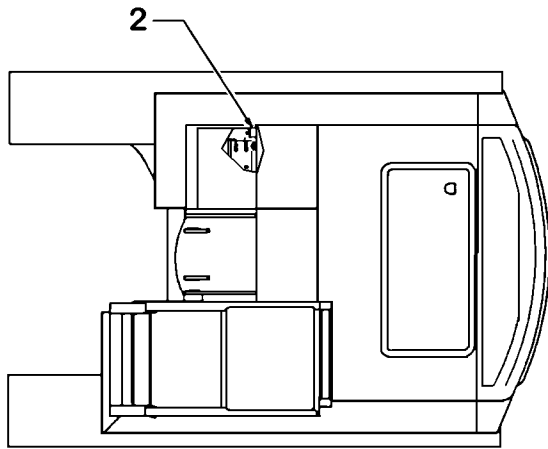

- 1. Power unit
- 2. Battery switch box

- 3. Tilt Switch box
- 4. Solenoid

VESM0183

15. Install o-ring (16) to piston.

16. Install brake piston (15).

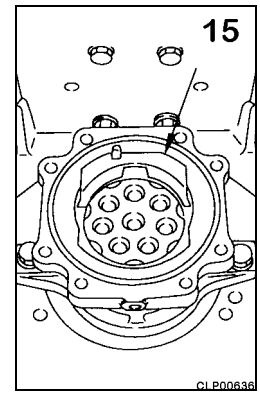
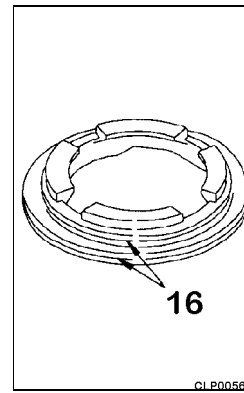

17. Set seven pistons (14) and center shaft in position. Using tool S14, tighten 7 retainer mounting screws.

★ Replace the mounting screws with new parts.

 Retainer screw Thread tightener [LT-2]

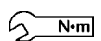
 **N•m** 1st step [tighten temporarily] Max 0.98 N•m
 2nd step 3.9 to 5.9 N•m
 3rd step 13.2 ± 1.5 N•m

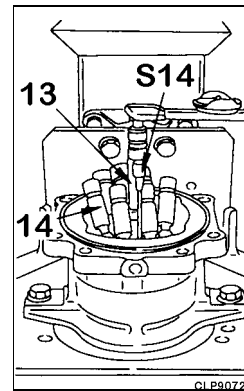

★ Remove all oil and grease from the threads [male and female] and dry completely.

★ Order for tightening; ①-④-⑦-③-⑥-②-⑤.

★ After tightening, wipe off any adhesive that has been squeezed out.

★ Check that the large ball of piston (14) and center shaft (13) move smoothly.

18. Using dial gauge E, measure play of piston (14) in axial direction.

 Play of piston Max 0.25 mm

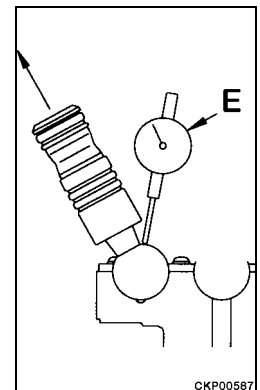
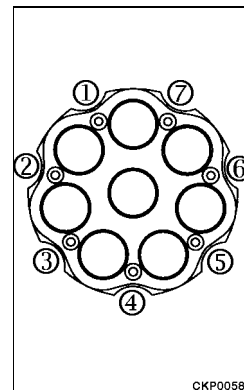

19. Position housing (6) on tool S13 together with tool S22, then adjust angle so that valve plate mounting surface is horizontal. Install valve plate (18).

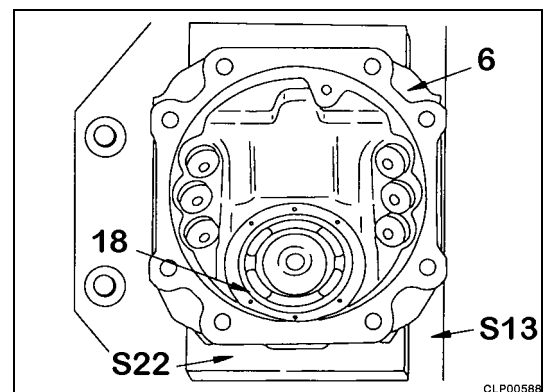

12. Install #2 sun gear (15) to #2 carrier, then install collar (14) and thrust washer (13).

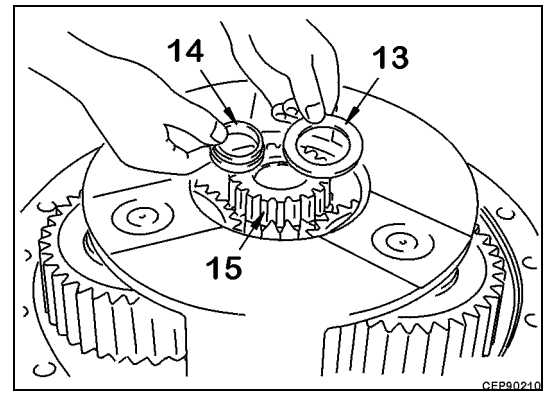

13. Raise ring gear (12) and install.

★ Align with the drain hole and assemble.

 Ring gear and case surface..... Gasket sealant [LG-6]

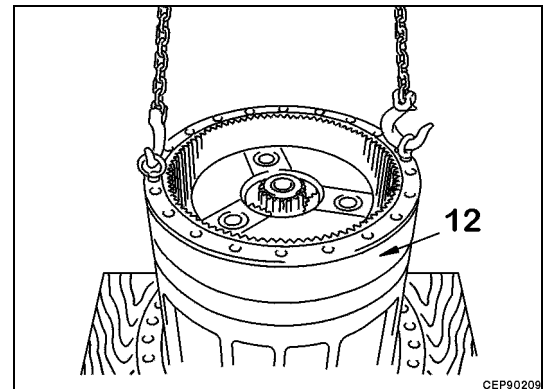

★ There are the remains of the staking when the pin is inserted at the end face of hole **h** at the side of the carrier, so remove the staked metal from the inside diameter of the hole before starting to assemble.

14. Assemble bearing (10) to gear (9), fit top and bottom thrust washers (8) and (11) and set gear to carrier (7).

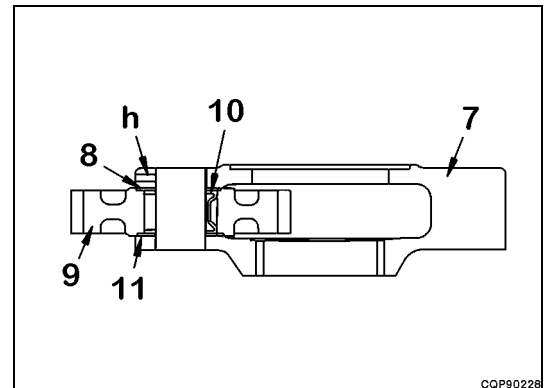

15. Align position of pin holes of shaft and carrier, then tap with a plastic hammer to install shaft (6).

★ When installing the shaft, rotate the planetary gear, and be careful not to damage the thrust washer.

16. Insert pin (5).

★ After inserting the pin, stake the pin portion of the carrier.

★ After assembling carrier, check that gear (9) rotates smoothly.

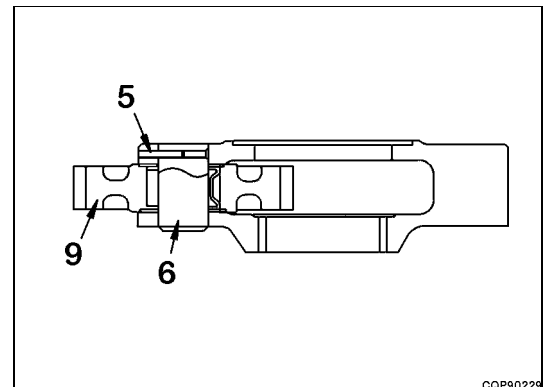

CLICK HERE TO **DOWNLOAD** THE COMPLETE MANUAL

- Thank you very much for reading the preview of the manual.
- You can download the complete manual from: www.heydownloads.com by clicking the link below



- Please note: If there is no response to CLICKING the link, please download this PDF first and then click on it.

CLICK HERE TO **DOWNLOAD** THE COMPLETE MANUAL