

HAYNES SERVICE & REPAIR MANUAL



KAWASAKI

ZX600 & 636 (ZX-6R)

'95 to '02



"Haynes Manuals just cannot be beaten"

Motor Cycle News

• Performance data • Model history • Wiring diagrams
• Tools and workshop tips
IN FULL COLOUR

CLICK HERE TO **DOWNLOAD** THE COMPLETE MANUAL

- Thank you very much for reading the preview of the manual.
- You can download the complete manual from: www.heydownloads.com by clicking the link below



- Please note: If there is no response to CLICKING the link, please download this PDF first and then click on it.

CLICK HERE TO **DOWNLOAD** THE COMPLETE MANUAL

Model development

ZX600F

The ZX-6R Ninja was first introduced in January 1995 as the model ZX600F1.

The engine was a light-weight, liquid cooled four-cylinder with double overhead camshafts driven by chain from the right-hand end of the crankshaft. The separate cylinder block was fitted with replaceable liners and the crankcases were split horizontally. The alternator and pick-up coil cover were made of magnesium.

A matrix-type oil cooler was mounted below the radiator and air was fed from the front, underside of the fairing to the air filter housing via Kawasaki's Twin Ram Air system.

Drive was transmitted to the six-speed gearbox via a multi-plate, four-spring clutch, and to the rear wheel by chain and sprockets.

The chassis comprised a twin-spar aluminium alloy frame with welded-on subframe and box-section, aluminium swingarm. Front suspension was by conventional, three-way adjustable telescopic forks and rear suspension was by a rising rate, three-way adjustable monoshock with remotely mounted gas reservoir.

Braking was by twin, semi-floating discs with four piston calipers at the front and a single disc with single piston caliper at the rear. Span adjusters were fitted to the clutch and front brake levers.

The ZX600F1 was available in Lime green and Pearl alpine white, Luminous rose opera and Pearl alpine white, Metallic eventide and Firecracker red.

The ZX600F2 was introduced in January 1996. Minor detail changes included an increase in the thickness of the front fork tube

walls. The ZX600F2 was available in Candy persimmon red and Metallic violet royal, Lime green and Pearl alpine white, Firecracker red.

The ZX600F3 was introduced in October 1996. The bike was available in Candy persimmon red, Galaxy silver, Lime green.

ZX600G (and H)

The ZX600G1 was introduced in March 1998. The bike featured a larger air intake and stainless steel exhaust system. An open-loop catalytic converter was fitted in the exhaust system of California ZX600G models, and German and Swiss ZX600H models. A heat-exchanger type oil cooler was incorporated in the engine-cooling system.

The rear sub-frame was now bolted-on instead of welded. New, six piston calipers were fitted to the front brakes and the thickness of the front discs was increased.

The ZX600G1 was available in Ebony and Firecracker red, Ebony and Pearl chateau grey, Lime green and Metallic violet royal, Sunbeam red.

The ZX600G2 was introduced in October 1998. It was available in Firecracker red, Lime green, Pearl gentry grey.

ZX600J

The ZX600J1 was introduced in January 2000.

A number of revisions were aimed at reducing weight and increasing power. A new, linerless, plated cylinder block and hemi-squish cylinder head were fitted together with a new crankshaft, connecting rods and pistons. The ignition system was uprated with 'stick' spark plug cap ignition coils. The valve

cover, oil sump, clutch cover and oil pump cover were made from magnesium. A catalytic converter was incorporated in the exhaust system of all models except those for the Australian market.

A new design of internally braced, extruded aluminium swingarm was introduced. The front brake calipers were modified with differential bore pistons and the diameter of the rear disc was reduced.

A new instrument cluster with LCD displays and LED warning lights was fitted. The new fairing with twin-headlights was inspired by the ZX-9R.

The ZX600J1 was available in Ebony and lime green, Firecracker red, Galaxy silver and Black pearl, Sunbeam red and Ebony.

The ZX600J2 was introduced in January 2001. It was available in Candy lightning blue, Candy lightning blue and Metallic nocturne blue, Lime green and Pearl purplish black mica, Pearl chrome yellow and Pearl purplish black mica.

The ZX600J3 was introduced in 2003 for the US market only. It was available in Galaxy silver and Black pearl, Lime green and Black pearl, Passion red and Black pearl, Pearl chrome yellow.

ZX636A1

The ZX636A1 was introduced in February 2002 for the European market only. The increase in engine capacity was achieved by an increase in the cylinder bore diameter. It was available in Galaxy silver and Black pearl, Lime green and black pearl, Passion red and black pearl.

Performance data

Maximum power

ZX600F model	.98 bhp (73 kW) @ 12,600 rpm
ZX600G model	.100 bhp (74.5 kW) @ 12,500 rpm
ZX600J model	.109.5 bhp (81.6 kW) @ 12,500 rpm
ZX636A model	.111 bhp (82.7 kW) @ 12,500 rpm

Maximum torque

ZX600F model	.46.3 lbf ft (62.7 Nm) @ 9,500 rpm
ZX600G model	.45.6 lbf ft (61.8 Nm) @ 9,500 rpm
ZX600J model	.48 lbf ft (65 Nm) @ 10,000 rpm
ZX636A model	.52.4 lbf ft (71 Nm) @ 9,800 rpm

Top speed

ZX600F model	.161 mph (259 km/h)
ZX600G models	.166 mph (267 km/h)
ZX600J and ZX636A models	.168 mph (279 km/h)

Average fuel consumption

<i>Miles per Imp gal, miles per litre, litres per 100 km</i>	
ZX600F model	.42 mpg, 9.2 mpl, 6.7 l/100 km
ZX600G, J and ZX636A models	.37.5 mpg, 8.2 mpl, 7.5 l/100 km

Fuel tank capacity

All models	.18 litres (3.96 Imp gal, 4.7 US gal)
------------	---------------------------------------

Fuel tank range

ZX600F model	.165 miles (265 km)
ZX600G, J and ZX636A models	.148 miles (238 km)

Performance data sourced from Motor Cycle News road test features. See the MCN website for up-to-date biking news.

 www.motorcyclenews.com

1.4 Routine maintenance and servicing

Component locations on the left-hand side – F models

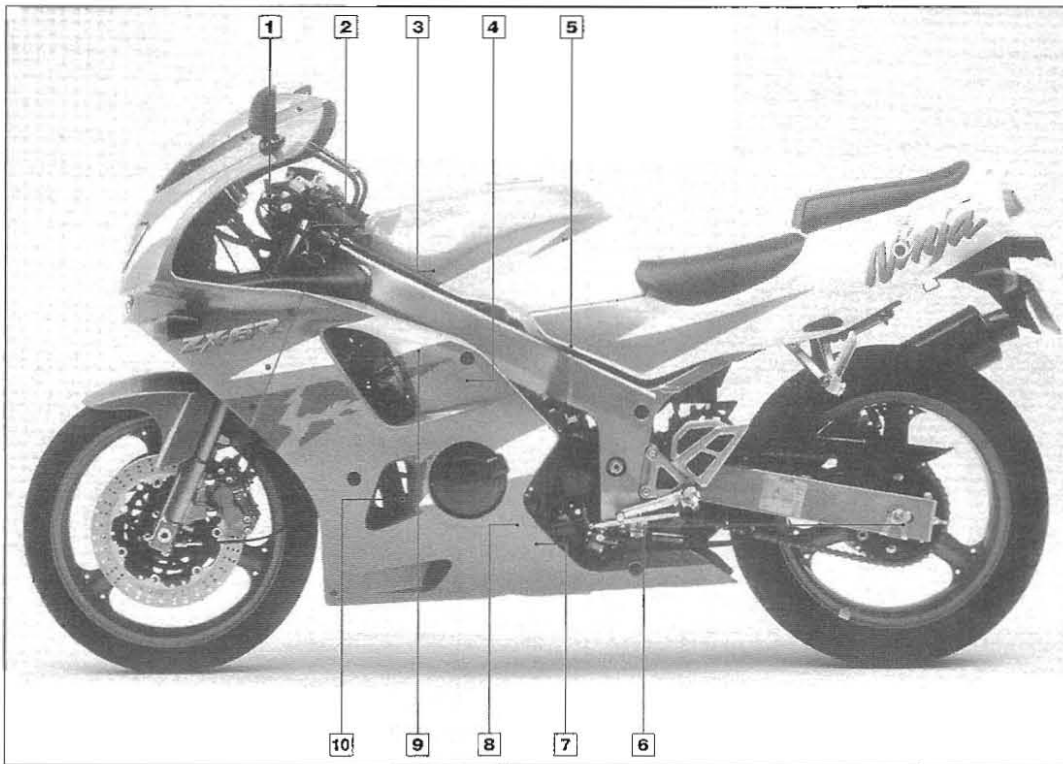

- 1 Clutch cable upper adjuster
- 2 Steering head bearings
- 3 Air filter
- 4 Coolant reservoir
- 5 Fuel (in-line) filter
- 6 Drive chain adjuster
- 7 Engine oil drain plug
- 8 Coolant drain bolt
- 9 Air suction valves, spark plugs and valves
- 10 Engine oil filter

Component locations on the left-hand side – G, H, J and A models

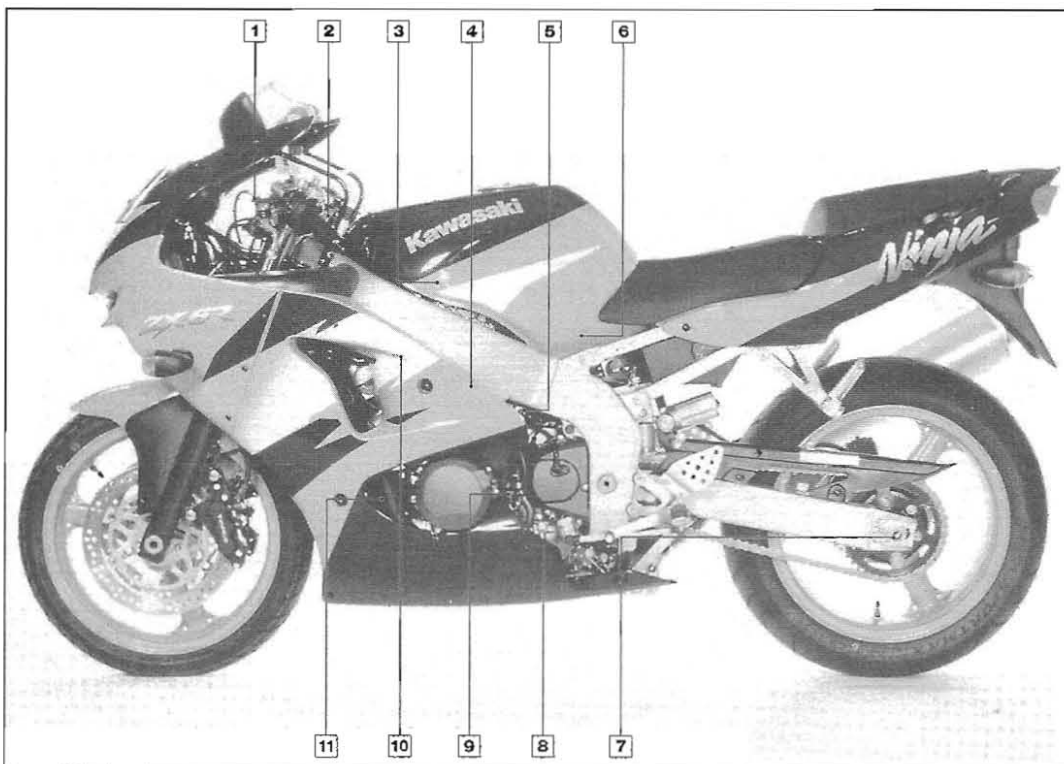

- 1 Clutch cable upper adjuster
- 2 Steering head bearings
- 3 Air filter
- 4 Coolant reservoir
- 5 Engine idle speed adjuster
- 6 Fuel (in-line) filter
- 7 Drive chain adjuster
- 8 Engine oil drain plug
- 9 Coolant drain bolt
- 10 Air suction valves, spark plugs and valves
- 11 Engine oil filter

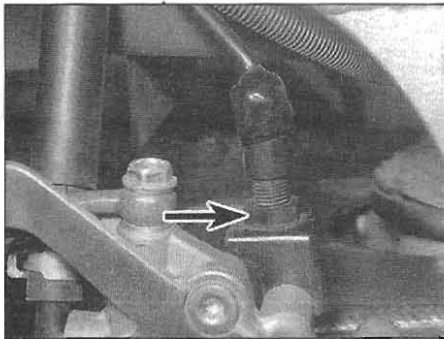

10.5 Hold the switch and turn the adjusting nut as required

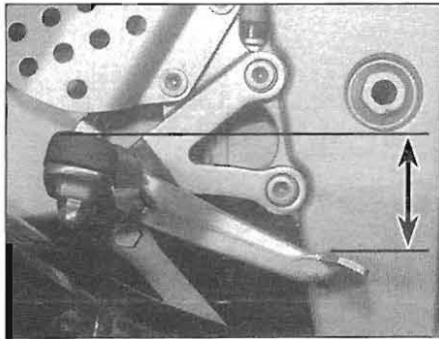

10.6a Measure the distance between the pedal tip and the top of the footrest as shown

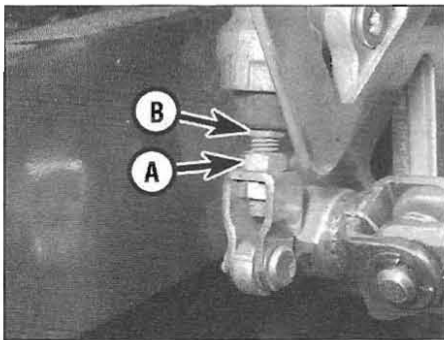

10.6b Slacken the locknut (A) and turn the pushrod using the hex (B)

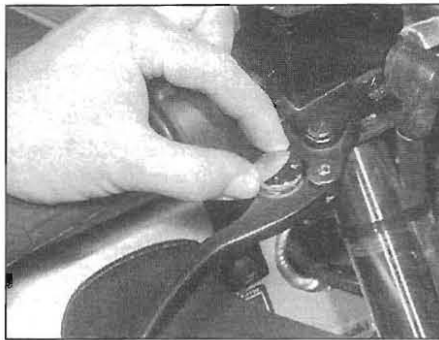

10.7 Pull the lever away from the handlebar and adjust the dial as required

5 Make sure the brake light is activated after about 10 mm of brake pedal travel or just before the rear brake takes effect. If adjustment is necessary, hold the switch and turn the adjusting nut on the switch body until the brake light is activated when required (see illustration). If the switch doesn't operate the brake lights, check it (see Chapter 9).

6 Check the position of the brake pedal. Kawasaki recommend that the distance from the pedal tip to the top of the rider's footrest should be as specified at the beginning of the Chapter (see illustration). If the pedal height is incorrect, or if the rider's preference is different, slacken the clevis locknut on the master cylinder pushrod, then turn the pushrod using a spanner on the hex at the top of the rod until the pedal is at the correct or

desired height (see illustration). If access to the pushrod is too restricted, remove the footrest bracket mounting bolts, then draw the bracket away from the frame, taking care not to twist or strain the brake hoses. On completion tighten the locknut securely. Adjust the rear brake light switch after adjusting the pedal height (see Step 5).

7 The front brake lever has a span adjuster which alters the distance of the lever from the handlebar (see illustration). Pull the lever away from the handlebar and turn the adjuster dial until the setting which best suits the rider is obtained. There are four positions on F models and five on all other models. Align the number for the setting required with the triangular mark on the lever bracket.

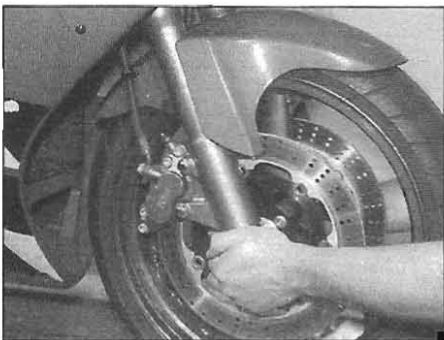

11.4 Checking for play in the steering head bearings

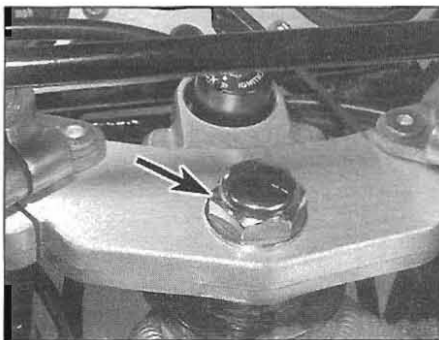

11.5a Slacken the steering stem nut (arrowed) ...

11 Steering head bearings – freeplay check and adjustment

Interval:

- F1 model – every 3000 miles (5000 km)
- All other models – every 4000 miles (6000 km)

1 The steering head bearings can become dented, rough or loose during normal use of the machine. In extreme cases, worn or loose steering head bearings can cause steering wobble – a condition that is potentially dangerous.

Check

- 2 Place the motorcycle on an auxiliary stand. Raise the front wheel off the ground either by having an assistant push down on the rear, or by removing the lower fairing panels (see Chapter 8) and placing a support under the engine.
- 3 Point the front wheel straight-ahead and slowly move the handlebars from side-to-side. Any dents or roughness in the bearing races will be felt and the bars will not move smoothly and freely. With the wheel pointing straight-ahead, tap the end of each bar to turn. The handlebars should travel to the full lock position under the force of gravity alone. If not, and it is not due to interference from wiring or cables, the bearings are over-tight.
- 4 Next, grasp the fork sliders and try to move them forward and backward (see illustration). Any looseness in the steering head bearings will be felt as front-to-rear movement of the forks. If play is felt in the bearings, adjust the steering head as follows:

HAYNES
HINT Freeplay in the fork due to worn fork bushes can be misinterpreted for steering head bearing play – do not confuse the two.

Adjustment

- 5 Remove the upper fairing (see Chapter 8) and the air filter housing (see Chapter 4). Slacken the steering stem nut, then slacken the fork clamp bolts in the bottom yoke (see illustrations).

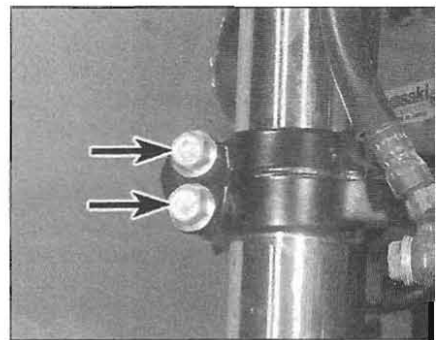

11.5b ... and the bottom yoke clamp bolts (arrowed) for each fork



22.3 Checking for leakage of the fork seals

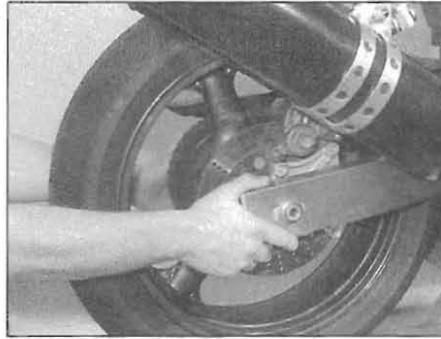

22.8a Checking for play in the swingarm bearings



22.8b Checking for play in the suspension and linkage

illustration). If leakage is evident, the seals must be renewed (see Chapter 6).

4 Check the tightness of all suspension nuts and bolts to be sure none have worked loose. Refer to the torque settings specified at the beginning of Chapter 6.

5 The forks are adjustable for spring pre-load, rebound damping and compression damping and it is essential that both fork legs are adjusted equally (see Chapter 6).

Rear suspension

6 Inspect the rear shock for fluid leaks and tightness of its mountings. If leakage is found, fit a new shock (see Chapter 6).

7 With the aid of an assistant to support the bike, compress the rear suspension several times. It should move up and down freely without binding. If any binding is felt, the worn or faulty component must be identified and renewed. The problem could be caused by the shock absorber, the suspension linkage components or the swingarm components.

8 Support the motorcycle using an auxiliary stand so that the rear wheel is off the ground. Grab the swingarm and rock it from side to side – there should be no discernible movement at the rear (see illustration). If there's a little movement or a slight clicking can be heard, inspect the tightness of all the rear suspension mounting bolts and nuts, referring to the torque settings specified at the beginning of Chapter 6, and re-check for movement. Next, grasp the top of the rear wheel and pull it upwards – there should be no discernible freeplay before the shock absorber begins to compress (see illustration). Any freeplay felt in either check indicates worn bearings in the swingarm, or worn shock absorber or suspension linkage mountings. The worn components must be renewed (see Chapter 6).

9 To make an accurate assessment of the swingarm bearings, remove the rear wheel (see Chapter 7) and the shock absorber (see Chapter 6). Grasp the rear of the swingarm with one hand and place your other hand at the junction of the swingarm and the frame. Try to move the rear of the swingarm from side-to-side. Any wear (play) in the bearings should be felt as movement between the swingarm and

the frame at the front. If there is any play the swingarm will be felt to move forward and backward at the front (not from side-to-side). Next, move the swingarm up and down through its full travel. It should move freely, without any binding or rough spots. If any play in the swingarm is noted or if the swingarm does not move freely, remove the swingarm and inspect the bearings (see Chapter 6).

23 Swingarm and suspension linkage bearings – lubrication

Interval:

F1 model – every 6000 miles (10,000 km)
All other models –
every 8000 miles (12,000 km)

1 Over a period of time the grease will harden or work out from behind the seals.
2 On F, G and H models the swingarm is not equipped with grease nipples. Remove the swingarm and suspension linkage as described in Chapter 6 to grease the bearings.
3 On J and A models, two grease nipples are fitted in the swingarm and three in the suspension linkage arm. Clean any road dirt off the nipples before applying the grease gun. Support the bike with the weight off the rear suspension, then pump general purpose grease into each bearing until new grease emerges from behind the seal at each end of the component (see illustration). Wipe off any surplus grease.



23.3 Greasing the suspension linkage bearings – J and A models

24 Nuts and bolts – tightness check

Interval:

F1 model – every 6000 miles (10,000 km)
All other models –
every 8000 miles (12,000 km)

1 Since vibration of the machine tends to loosen fasteners, all nuts, bolts, screws, etc. should be periodically checked for proper tightness.

2 Pay particular attention to the following:

- Spark plugs
- Engine oil drain plug
- Gearchange lever bolt
- Footrest and stand bolts
- Engine mounting bolts
- Shock absorber mounting bolts
- Handlebar bolts
- Front axle and axle clamp bolts
- Front fork clamp bolts (top and bottom yoke)
- Rear axle nut
- Swingarm pivot nut
- Brake caliper mounting bolts
- Brake hose banjo bolts and caliper bleed valves
- Brake disc bolts and rear sprocket nuts
- Exhaust system bolts/nuts

3 If a torque wrench is available, use it along with the torque specifications at the beginning of this, or the appropriate, Chapter.

25 Brake fluid – change

Interval:

F1 model –
every 12,000 miles (20,000 km)
All other models –
every 16,000 miles (24,000 km)

1 The brake fluid should be changed at the prescribed interval or whenever a master cylinder or caliper overhaul is carried out. Follow the procedure described in the brake bleeding section in Chapter 7. Ensure that all the old fluid is pumped from the hydraulic

as a number of factors must be considered.
 2 High mileage is not necessarily an indication that an overhaul is needed, while low mileage, on the other hand, does not preclude the need for an overhaul. Frequency of servicing is probably the single most important consideration. An engine that has regular and frequent oil and filter changes, as well as other required maintenance, will most likely give many miles of reliable service. Conversely, a neglected engine, or one which has not been broken in properly, may require an overhaul very early in its life.

3 Exhaust smoke and excessive oil consumption are both indications that piston rings and/or valve guides are in need of attention. Make sure oil leaks are not responsible before deciding that the rings and guides are bad. Refer to Chapter 1 and perform a cylinder compression check to determine for certain the nature and extent of the work required.

4 Low oil pressure is usually an indicator of excessive crankshaft bearing wear or a worn out oil pump. To check the oil pressure, refer to Chapter 1. If the oil pressure is lower than specified, inspect the oil passages for clogging, and inspect the oil pump, oil pressure relief valves and the crankshaft bearing inserts for excessive wear.

5 If the engine is making obvious knocking or rumbling noises, the connecting rod and/or main bearings are probably at fault.

6 Loss of power, rough running, excessive valve train noise and high fuel consumption rates may also point to the need for an overhaul, especially if they are all present at the same time. If a complete tune-up does not remedy the situation, major mechanical work is the only solution.

7 An engine overhaul generally involves restoring the internal parts to the specifications of a new engine. The piston rings, main and connecting rod bearings are usually renewed during a major overhaul. The valve seats are re-ground and, if necessary, re-cut by a specialist engineer, since they are usually in less than perfect condition at this point. The end result should be a like-new engine that will give as many trouble free miles as the original.

8 Before beginning the engine overhaul, read through all of the related procedures to

familiarise yourself with the scope and requirements of the job. Overhauling an engine is not all that difficult, but it is time consuming. Plan on the motorcycle being tied up for a minimum of two weeks. Check on the availability of parts and make sure that any necessary special tools, equipment and supplies are obtained in advance.

9 Most work can be done with typical workshop hand tools, although a number of precision measuring tools are required for inspecting parts to determine if they must be renewed. Often a dealer service department or motorcycle repair shop will handle the inspection of parts and offer advice concerning reconditioning and renewal.



As a general rule, time is the primary cost of an overhaul so it doesn't pay to install worn or substandard parts.

10 As a final note, to ensure maximum life and minimum trouble from a rebuilt engine, everything must be assembled with care in a spotlessly clean environment.

5 Engine – removal and installation



Warning: Engine removal and installation should be done with the aid of at least one assistant – and preferably two – to avoid back injuries, or injuries that could occur if the engine is dropped. An hydraulic or mechanical floor jack should be used to support and lower the engine if possible. Always make sure the motorcycle is properly supported and secure.

Removal

1 Support the bike securely in an upright position using an auxiliary stand. Work can be made easier by raising the machine to a suitable working height on an hydraulic ramp or a suitable platform. Make sure the motorcycle is secure and will not topple over

(see *Tools and Workshop Tips* in the Reference section). Apply the front brake and secure the lever in that position using a cable tie.

2 If the engine is dirty, particularly around its mountings, wash it thoroughly before starting any major dismantling work. This will make work much easier and rule out the possibility of caked on lumps of dirt falling into some vital component.

3 Remove the seats, the side panels and the lower fairing panels (see Chapter 8). Though not strictly necessary, it is also advisable to remove the upper fairing to improve access and clearance and to prevent the possibility of damaging it (see Chapter 8).

4 Remove the fuel tank and the air filter housing (see Chapter 4).

5 On F, G and H models, lift the vacuum valve switch bracket off the vacuum valve hoses, then detach the vacuum valve switch hose from the carburetors and remove the switch, noting how it fits and where the hoses connect (see illustration). Also detach the vacuum valve hoses from the suction valve covers and the carburetors and remove the valve, noting how it fits and where the hoses connect. On J and A models, detach the vacuum valve hoses from the suction valve covers, then detach the valve switch hose from the carburetors and lift off the valve assembly (see illustration).

6 Drain the coolant and the engine oil (see Chapter 1).

7 On F models, remove the ignition coils (see Chapter 5). On G and H models, check that the cylinder location is marked on each plug lead, then pull the spark plug cap off each spark plug. On J and A models, check that the cylinder location is marked on each ignition coil/cap wiring connector, then disconnect the connectors and carefully remove the coil/caps. **Note: Do not attempt to lever the coil/caps off the plugs or pull them off with pliers. Do not drop the coil/caps.** Temporarily undo the right-hand suction valve cover bolt and detach the earth (ground) wire from the coil/cap wiring loom (see illustration). Release the loom from the clips along the back edge of the valve cover baffle plate and secure it clear of the engine.

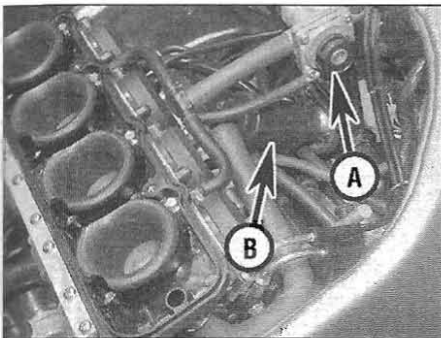

5.5a Remove the vacuum valve switch (A) and the vacuum valve (B), noting where their hoses connect – F, G and H models

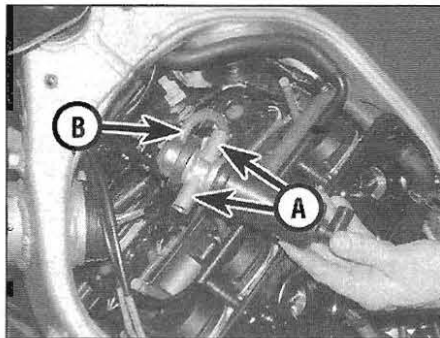

5.5b Detach the hoses from the suction valves (A) and the carburetors (B) – J and A models

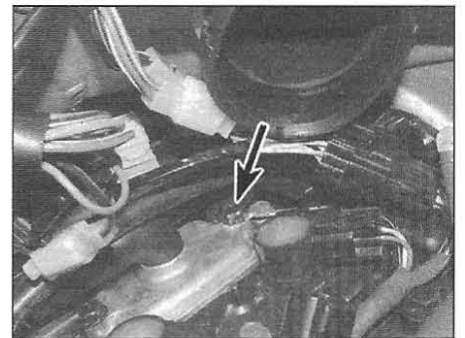

5.7 Detach the earth (ground) wire (arrowed) from the suction valve cover

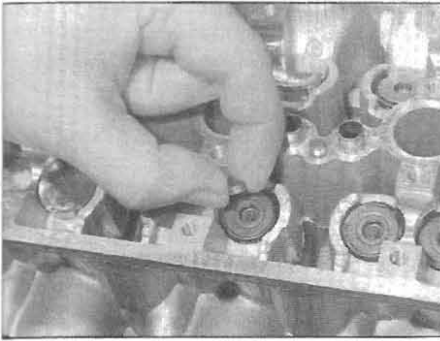

9.19a Fit the shim into the recess in the top of the valve ...



9.19b ... then install the follower



9.20a Fit a new O-ring around each dowel ...

seriously out-of-round or tapered, the cylinder head and the followers must be renewed.

Installation

19 Lubricate each shim and its follower with molybdenum disulphide grease or engine oil and install them in the cylinder head (see illustrations). Make sure each shim is correctly seated in the top of the valve assembly, and make sure each follower fits squarely in its bore. **Note:** It is most important that the shims and followers are returned to their original valves otherwise the valve clearances will be inaccurate.

20 Make sure the bearing surfaces in the cylinder head and the camshaft holder are clean, then apply engine oil to each of them. Fit the dowels if removed, then fit a new O-ring around each dowel adjacent to the spark plug holes, and around each spark plug hole (see illustrations).

21 Verify that the T 1.4 mark on the timing rotor is still aligned (see Step 3) (see illustration 9.3b or c). When installing the camshafts, align the marks on the camshaft sprockets exactly with the cylinder head surface (see illustration). The EX mark on the sprocket must be facing forwards, towards the exhaust, and the IN mark must be facing backwards, towards the inlet side. Do not mix the camshafts up (see illustration 9.6a). Apply engine oil (or a coat of engine assembly lube or molybdenum disulphide grease if new camshafts are being fitted) to the lobes. Make sure the camshaft bearing journals are clean, then lay the exhaust camshaft (marked 117 EX) onto the front of the head (see illustration). Fit the cam chain around the sprocket. When fitting the chain, pull up on the front run to remove all slack from it. Now lay the inlet camshaft (marked 117 IN) onto the rear of the head and fit the cam chain around the sprocket, making sure there is no slack in the chain between the camshafts (see illustration).

22 Count the number of chain link pins between the front EX mark and the rear IN mark (see illustration). There should be 30 link pins and no slack in the chain between the two sprockets, or in the front run of the chain. Any slack in the chain must be in the rear run, so that it is taken up by the tensioner when it is installed.



9.20b ... and spark plug hole

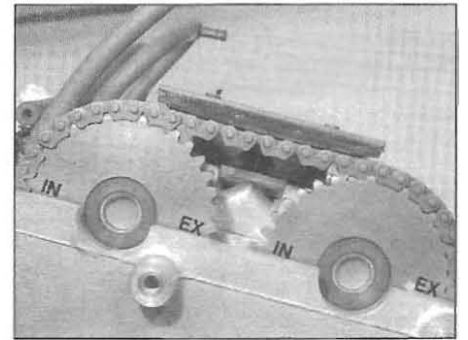

9.21a When installing the camshafts, align the sprocket marks as shown

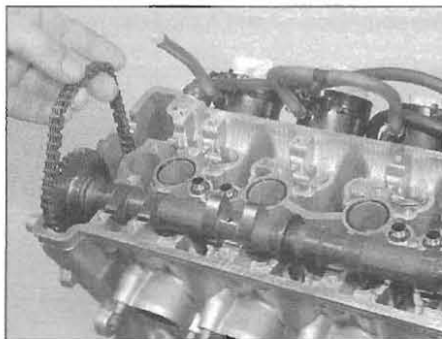

9.21b Install the exhaust camshaft ...

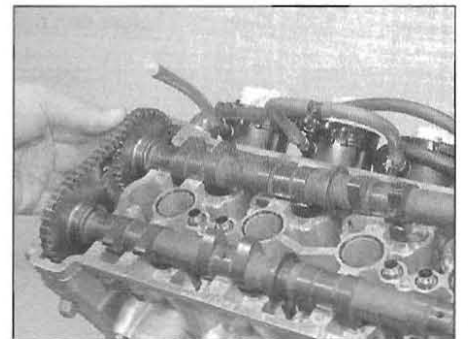

9.21c ... followed by the inlet camshaft

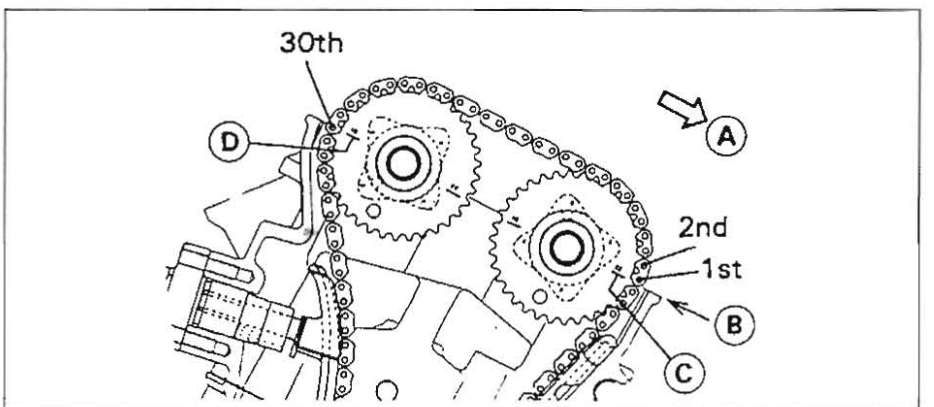

9.22 Check that the cam chain is fitted as described around the sprockets

- | | |
|-------------------------|------------------------------------|
| A Front of engine | C Front (exhaust) sprocket EX mark |
| B Cylinder head surface | D Rear (inlet) sprocket IN mark |

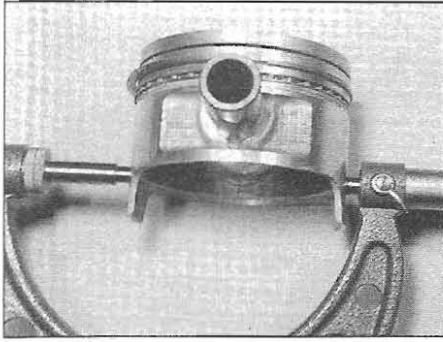

14.12 Measure the piston diameter at the specified distance from the bottom of the skirt using a micrometer

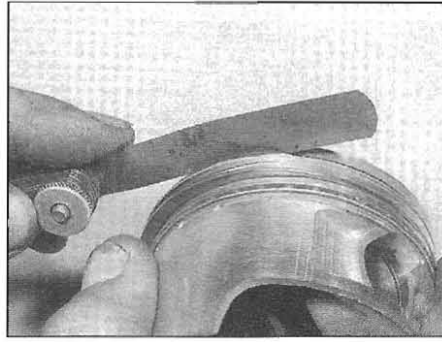

14.13 Measure the piston ring-to-groove clearance using a feeler gauge

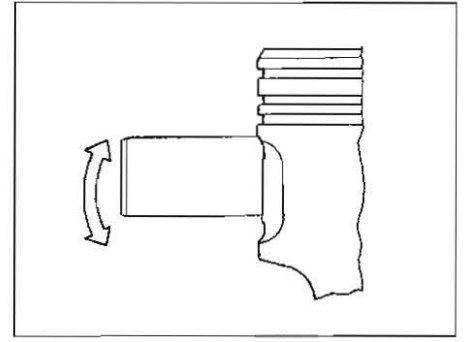

14.14 Slip the pin into the piston and feel for freeplay

the bottom of the skirt (see illustration). Subtract the piston diameter from the bore diameter to obtain the clearance. If it is greater than the specified figure, check whether it is the piston or the bore that is worn beyond the service limit. If the bores are good, install new pistons and rings. If the bores are worn, new cylinder liners or a new cylinder block will have to be fitted (see Section 13).

13 Measure the piston ring-to-groove clearance by laying a new piston ring in the ring groove and slipping a feeler gauge in beside it (see illustration). Check the clearance at three or four locations around the groove. Be sure to use the correct ring for each groove; they are different (see Step 6). If the clearance is greater than specified, new pistons will have to be used when the engine is reassembled.

14 Apply clean engine oil to the pin, insert it into the piston and check for freeplay by rocking the pin back-and-forth (see illustration). If the pin is loose, new pistons and possibly new pins must be installed.

Installation

Note: Install the pistons for cylinders 2 and 3 first.

15 Inspect and install the piston rings (see Section 15).

16 Lubricate the piston pin, the piston pin bore and the connecting rod small-end bore with clean engine oil.

17 When installing the pistons onto the

connecting rods, make sure that arrow on the piston crown points to the front of the engine (see Step 3). Install a new circlip in one side of the piston (never re-use old circlips). Line up the piston on its correct connecting rod, and insert the piston pin from the other side (see illustration 14.4b). Secure the pin with the other new circlip. When installing the circlips, compress them only just enough to fit them in the piston, and make sure they are properly seated in their grooves with the open end away from the removal notch (see illustration 14.4a).

18 Install the remaining components in the reverse order of removal.

15 Piston rings – installation



1 It is good practice to fit new piston rings when an engine is being overhauled. Before installing the new piston rings, the ring end gaps must be checked with the rings installed in the cylinder.

2 Lay out the pistons and the new ring sets so the rings will be matched with the same piston and cylinder during the end gap measurement procedure and engine assembly. The top and second compression rings have different profiles and the upper surface of each ring is marked with a letter at

one end. The top ring is identified by the letter R, and the second (middle) ring by the letters RN.

3 Insert the top ring into the bottom of the first cylinder and square it up with the cylinder walls by pushing it in with the top of the piston. The ring should be about 20 mm above the bottom edge of the cylinder. To measure the end gap, slip a feeler gauge between the ends of the ring (see illustration) and compare the measurement to the Specifications.

4 If the gap is larger or smaller than specified, double check to make sure that you have the correct rings before proceeding. Excess end gap is not critical unless it is greater than the specified limit. Again, double check to make sure you have the correct rings for your engine.

5 Repeat the procedure for each ring that will be installed in the first cylinder and for each ring in the remaining cylinder. Remember to keep the rings, pistons and cylinders matched up.

6 Once the ring end gaps have been checked/corrected, the rings can be installed on the pistons. The oil control ring (lowest on the piston) is installed first. It is composed of three separate components. Slip the expander into the groove, making sure its ends butt against each other and do not overlap, then install the lower side rail (see illustrations). Do not use a piston ring



15.3 Measuring piston ring installed end gap



15.6a Install the oil ring expander in its groove, making sure the ends do not overlap ...



15.6b ... and fit the side rails each side of it. The oil ring must be installed by hand

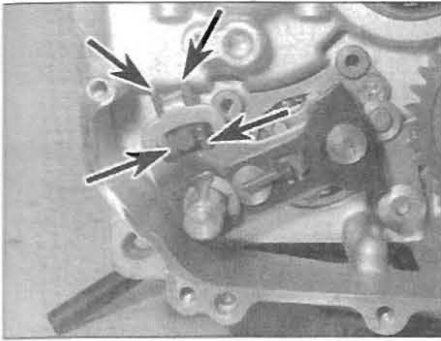

21.11 Make sure the spring ends (arrowed) are correctly located



21.12a Fit new O-rings . . .

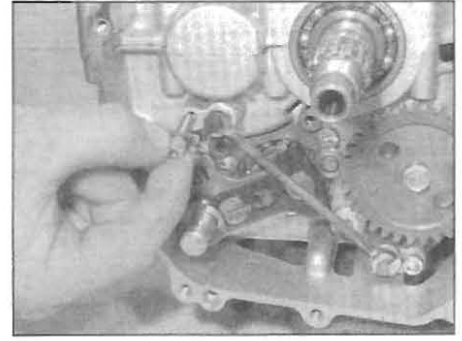

21.12b . . . then install the pipe, holders and bolts

11 Slide the shaft into place and push it all the way through the case until the splined end comes out the other side, lifting the selector arm slightly as you do and engaging it with the pins on the stopper plate (see illustration 21.4). Make sure the centralising spring ends locate correctly on each side of the locating pin (see illustration).

12 Fit a new O-ring onto each end of the oil pipe and press the ends into their bores (see illustration). Fit the holders and tighten the bolts to the specified torque (see illustration).

13 Install the clutch (see Section 20).

14 Align the split in the gearchange linkage arm with the mark previously made on the shaft, then fit the arm on the shaft and tighten the pinch bolt securely (see illustration 21.1).

22 Starter clutch, idle/reduction gear assembly – removal, inspection and installation

Note: The starter clutch and idle gear assembly can be removed with the engine in the frame.

Removal

1 To check the operation of the starter clutch, remove the alternator cover (see Chapter 9), then turn the starter driven gear by hand. It should turn freely in a clockwise direction (when viewed straight on), but should lock against the alternator rotor when turned in an

anti-clockwise direction (see illustration). If not, remove and inspect the components as described below.

2 Remove the alternator rotor (see Chapter 9). The starter driven gear should come away with the rotor. If it doesn't, remove it from the crankshaft. The starter clutch is secured to the back of the rotor by three Allen bolts (see illustration).

Inspection

3 To check the operation of the starter clutch, place the alternator rotor face down on the workbench and install the starter driven gear. The gear should rotate freely in an anti-clockwise direction and lock against the rotor in a clockwise direction. If it doesn't, renew the starter clutch – it is secured to the rotor by three Allen bolts. When installing a new one, apply a suitable non-permanent thread locking compound to the bolt threads and tighten them to the torque setting specified at the beginning of the Chapter, using a strap wrench to hold the rotor.

4 Withdraw the starter driven gear from the starter clutch. If it appears stuck, rotate it anti-clockwise as you withdraw it to free it from the starter clutch.

5 Check the bearing surface of the starter driven gear hub and the condition of the sprags inside the clutch body. If the bearing surface shows signs of excessive wear or the sprags are damaged, the gear or the clutch body should be renewed.

6 If required, remove the sprags and check the plungers and springs for signs of deformation or damage. Make sure the plungers move freely in their sockets.

7 Check that the three Allen bolts securing the starter clutch to the alternator rotor are tight. If any are loose, unscrew all the bolts, then apply a suitable non-permanent thread locking compound to their threads and tighten them to the torque setting specified at the beginning of the Chapter, using a strap wrench to hold the rotor. Lubricate the starter clutch sprags with clean engine oil.

8 Examine the teeth of the starter idle/reduction gear and the corresponding teeth of the starter driven gear and starter motor drive shaft. Fit new gears and/or starter motor if any of the teeth are worn or chipped.

Installation

9 Lubricate the hub of the starter driven gear with clean engine oil, then install the starter driven gear into the starter clutch, rotating it anti-clockwise as you do so to spread the sprags and allow the hub of the gear to enter.

10 Install the alternator rotor (see Chapter 9).

23 Crankcase – separation and reassembly

1 To examine and repair or renew the crankshaft, connecting rods, bearings, and/or

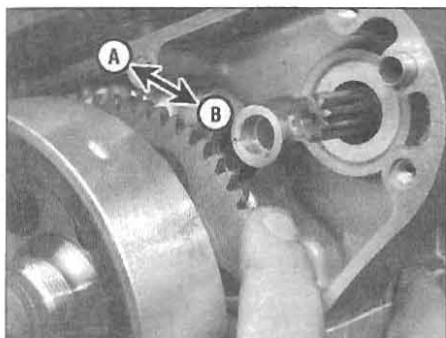

22.1 Check that the starter clutch won't turn anticlockwise (A), but turns freely clockwise (B)

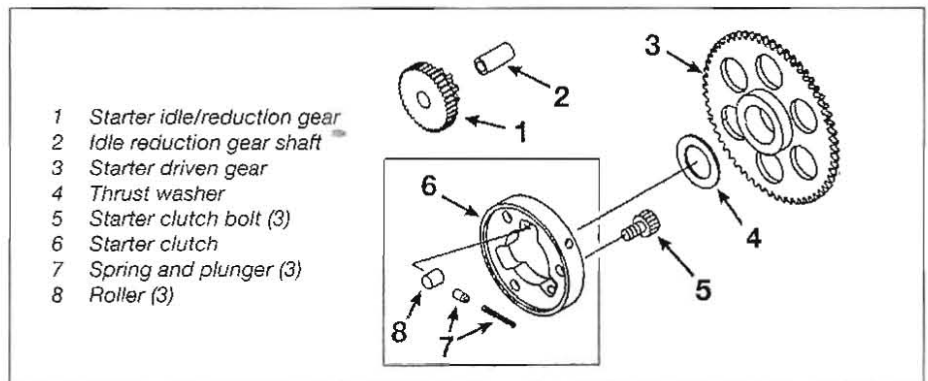

22.2 Starter clutch components

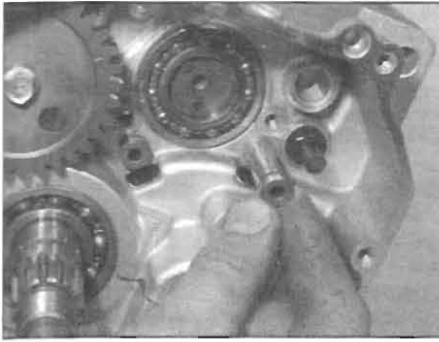

30.4 ... then withdraw the shafts and remove the forks ...

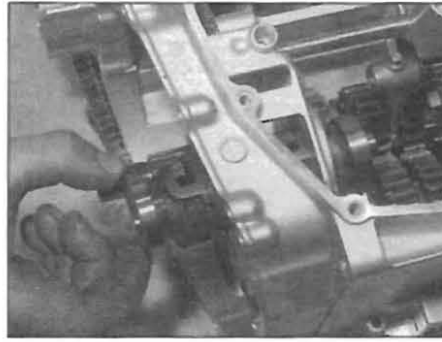

30.5 ... and slide the drum out

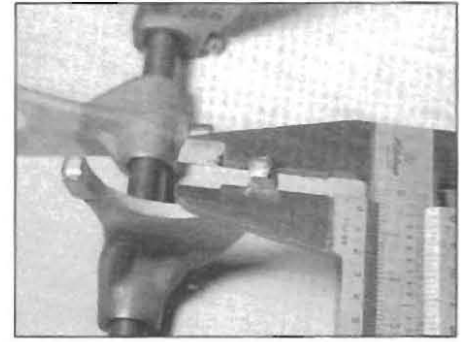

30.7a Measure the fork end thickness as shown ...

4 Mark each fork according to its fitted location and note which way round they fit. Support the selector forks and pull the shafts out (see illustration).

5 Swing each fork away from the selector drum, noting how the guide pins locate in the selector drum grooves. Slide the selector drum out of the crankcase (see illustration). Lift the forks out of the casing and reassemble them on the shafts as soon as they're removed so they can be returned to their original positions.

Inspection

6 Inspect the selector forks for any signs of wear or damage, especially around the fork ends where they engage with the groove in the pinion. Check that each fork fits correctly in its pinion groove. Check closely to see if the forks are bent. If the forks are in any way damaged they must be renewed.

7 Measure the thickness of the fork ends and the width of its groove in the relevant pinion and compare the readings to the specifications (see illustrations). Renew whichever components are worn beyond their specifications.

8 Check that the forks fit correctly on their shaft. They should move freely with a light fit but no appreciable freeplay. Check that the fork shaft holes in the crankcases are not worn or damaged.

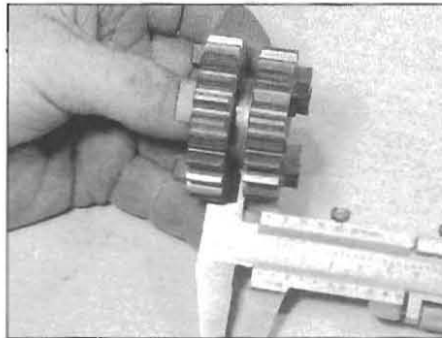

30.7b ... and the width of its pinion groove

9 The selector fork shaft can be checked for trueness by rolling it along a flat surface. A bent rod will cause difficulty in selecting gears and make the gearshift action heavy. Renew the shaft if it is bent.

10 Inspect the selector drum grooves and selector fork guide pins for signs of wear or damage. Measure the width of each groove and the diameter of the corresponding fork guide pin and compare the results to the specifications. If any component is worn beyond its service limit or is damaged, it must be renewed.

11 Check that the selector drum bearing rotates freely and has no rough spots. There

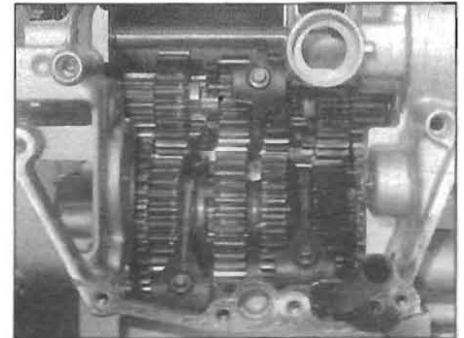

30.12 Locate each fork into its pinion groove as shown

should be no excessive freeplay between the bearing, the drum and the crankcase. Renew the bearing if necessary.

Installation

12 Lubricate all parts with engine oil before installing them. Locate each fork into its correct pinion groove, making sure they are the correct way round (see illustration). Swing the forks clear so they do not impede the selector drum as it is installed.

13 Slide the selector drum into the casing, making sure the shaft end enters its bore, and aligning the small hole with the neutral switch contact plunger (see illustrations).

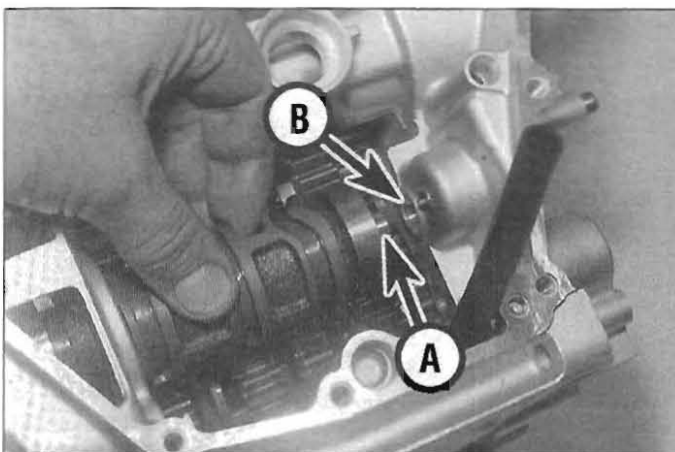

30.13a Fit the end of the selector drum (A) into the bore (B) ...

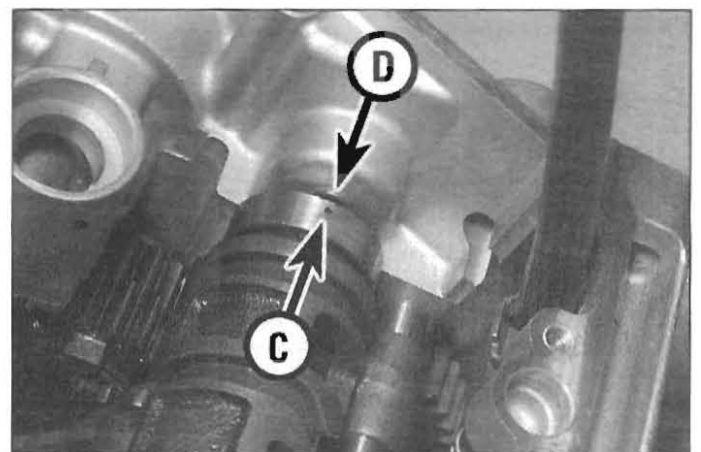

30.13b ... and align the hole (C) with the neutral contact (D)

CLICK HERE TO **DOWNLOAD** THE COMPLETE MANUAL

- Thank you very much for reading the preview of the manual.
- You can download the complete manual from: www.heydownloads.com by clicking the link below



- Please note: If there is no response to CLICKING the link, please download this PDF first and then click on it.

CLICK HERE TO **DOWNLOAD** THE COMPLETE MANUAL

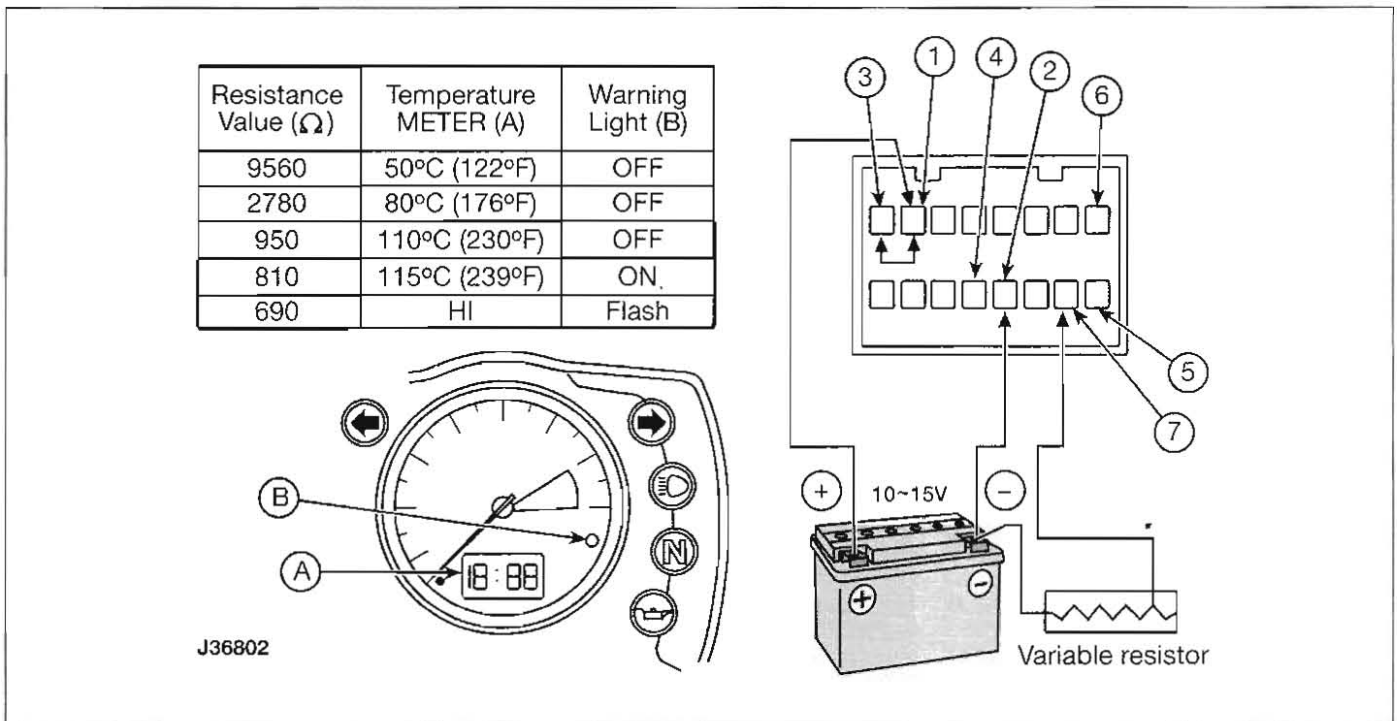

5.4 Temperature gauge test set-up – J and A models

between the No 1 and No 3 terminals on the connector. Connect the resistor between the No. 7 terminal on the connector and the battery negative terminal. Starting with the resistor at the 25 K ohm setting, slowly reduce the resistance to zero. As the resistance drops, the display segments of the temperature gauge should illuminate at the appropriate values in the table. If the segments do not illuminate, or they do so at resistance values different to those specified, the gauge is faulty and must be renewed. **Note:** The connector terminals on the instrument cluster are very closely spaced – take great care when connecting test wires to them.

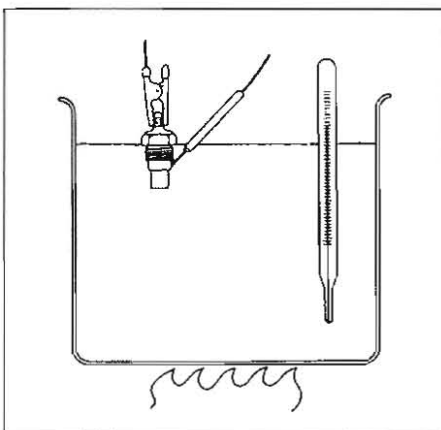

5.5 Suspend the sensing and threaded portion in the water and measure the resistance as the water heats up

4 To check the gauge on J and A models, first remove the instrument cluster and test the start-up and display button operations (see Chapter 9). If the test is good, check the operation of the gauge with a variable resistor with a zero to 96 K ohm range. If this is not available, the gauge should be checked by a Kawasaki dealer. If the resistor is available, connect the positive terminal of a 12 V battery to the No. 1 terminal on the cluster wiring connector, and the battery negative terminal to the No. 2 terminal (see illustration). Use a jumper wire to connect between the Nos. 1 and 3 terminals. Connect the resistor between the No. 7 terminal and the battery negative terminal. Starting with the resistor at the 96 K ohm setting, slowly reduce the resistance to zero. As the resistance drops, the temperature gauge should display the corresponding temperatures shown in the table. If the temperatures are not displayed, or they are displayed at resistance values different to those specified, the gauge is faulty and must be renewed. **Note:** The connector terminals on the instrument cluster are very closely spaced – take great care when connecting test wires to them.

5 On all models, if the gauge passes these tests, but doesn't operate correctly under normal riding conditions, the temperature sensor is probably defective. Remove the sensor (see Steps 7 and 8 below). Fill a small heatproof container with coolant and place it on a stove. Using an ohmmeter, connect the positive (+ve) probe of the meter to the terminal on the sensor, and the negative (-ve) probe to the body of the sensor. Using some

wire or other support suspend the sensor in the coolant so that just the sensing portion and the threads are submerged. Also place a thermometer capable of reading temperatures up to 120°C in the water so that its bulb is close to the sensor (see illustration). **Note:** None of the components should be allowed to directly touch the container.

6 Heat the coolant, stirring it gently.



Warning: This must be done very carefully to avoid the risk of personal injury.

As the temperature of the coolant rises, compare the resistance readings on the ohmmeter at the temperatures specified at the beginning of the Chapter. If the meter readings obtained are different, or they are obtained at different temperatures, then the sensor is faulty and must be renewed.

7 If the sensor is proven good, the fault lies in the wiring or an intermittent fault in the gauge itself. Check all the relevant wiring and wiring connectors (see Chapter 9). If all appears to be well, have the gauge checked by a Kawasaki dealer.

Removal and installation

Coolant temperature sensor



Warning: The engine must be completely cool before beginning this procedure.

8 Drain the cooling system (see Chapter 1) and remove the fuel tank (see Chapter 4). The sensor is screwed into the back of the cylinder head (see illustration 5.2). Disconnect the sensor wiring connector and unscrew the sensor.

Fuel Pump Relay Internal Resistance

Range x 1 kΩ	Tester (+) Lead Connection			
	1	2	3	4
* 1	∞	∞	∞	∞
2	∞	∞	∞	∞
3	∞	10-100	∞	∞
4	∞	20-200	1-5	∞

*: Tester (-) Lead Connection

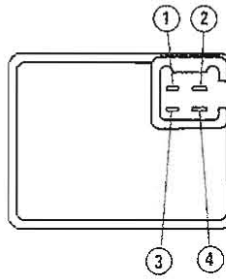

3.7 Terminal identification and resistance table for testing the fuel pump relay

at the indicated terminals (see illustration). If your readings are not as specified in the table, fit a new fuel pump relay. If your readings are okay, check the fuel pump itself.

Caution: Using a meter other than that specified may produce inaccurate results and could damage the fuel pump relay. If the meter is not available, have the relay checked by a Kawasaki dealer.

Check – fuel pump



Warning: To protect your eyes from spilled or splashed paraffin (kerosene), wear safety goggles during the following test procedure.

Note: If you don't have a suitable automotive-type fuel pressure gauge for this procedure, take the pump to a Kawasaki dealer and have it tested there.

8 Remove the fuel pump with the fuel filter (see Steps 2 to 4 above).

9 Fill a container with paraffin (kerosene) and hook up the fuel pump, hoses and filter as shown (see illustration). Connect a fuel pressure gauge to the high pressure side with a T-fitting as shown.



Warning: Do NOT use petrol (gasoline) for this test! It is unnecessary and dangerous.

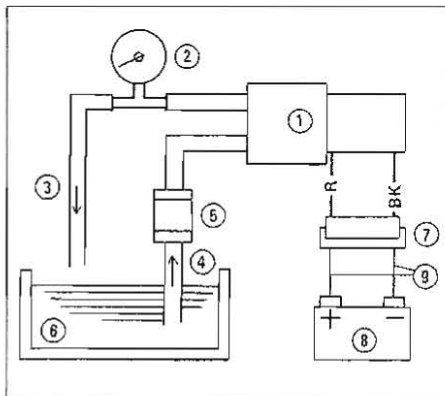

3.9 Fuel pump test set-up

- 1 Fuel pump
- 2 Pressure gauge
- 3 Outlet hose
- 4 Inlet hose
- 5 Fuel filter
- 6 Paraffin (kerosene)
- 7 2-pin connector
- 8 12V battery
- 9 Jumper leads

10 Hook up the pump wiring connector to a 12-volt battery as shown (see illustration 3.9) and note whether the pump comes on:

- If the pump operates, check the pump relay.
- If the pump does not operate, fit a new pump.
- If the pump operates AND the fuel pump relay is also okay, close the outlet hose momentarily while the pump is running – when the pump stops, note the indicated pressure on the fuel pressure gauge and compare this reading to the fuel pressure listed in this Chapter's Specifications. If the gauge reading is outside that spec, the pump is defective.

Installation

11 Installation is the reverse of removal (see illustration 3.4). Make sure all the hose clamps are a tight fit.

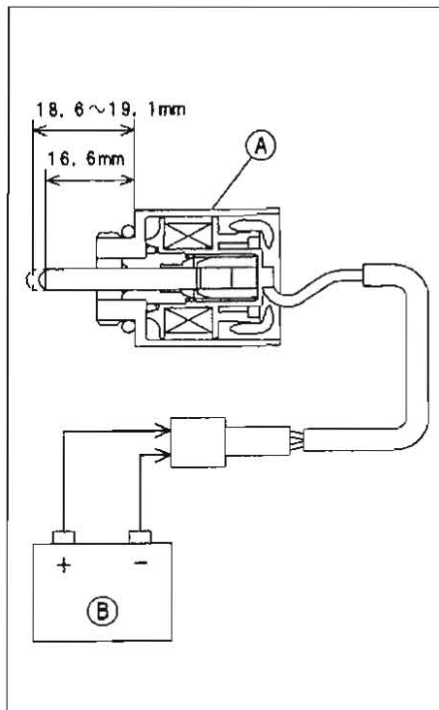

3.15 Fuel cut-off valve test set-up
A Cut-off valve B 12V battery

Fuel pump cut-off valves (catalytic converter models)

Removal

12 The valves are installed to protect the catalytic converter fitted to these models. Remove the fuel tank (see Section 2).

13 Connect a suitable drain hose to the union on the bottom of the float chamber on each carburettor and place the end in a suitable container. Slacken each drain screw in turn and drain the carburettors. Tighten the drain screws on completion.

14 Disconnect each cut-off valve wiring connector, then unscrew each valve from the carburettors, noting which fits where.

Check

15 To test the valve, first measure the amount of protrusion of the plunger as shown (see illustration). Now connect a 12V battery to the terminals of the wiring connector and measure the protrusion. If the valve plunger does not move when the battery is connected, or if the amount of protrusion differs from that specified, fit a new valve.

Installation

16 On installation, the valves with the grey wiring connectors must be fitted to Nos. 1 and 4 carburettors, and the valves with the brown connectors must be fitted to Nos. 2 and 3 carburettors.

4 Air filter housing – removal and installation



Removal

1 Remove the fuel tank (see Section 2).
2 Release the clamp and detach the crankcase breather hose from the air filter over. On F models, also detach the vacuum valve hose from the cover and the drain hose from the housing on the left-hand side (see illustration).

3 Remove the air filter (see Chapter 1). Unscrew the two bolts securing the housing to the carburettors and remove the housing, lifting it up at the rear and drawing it out of the

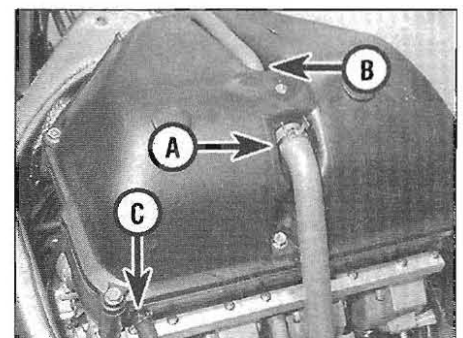

4.2 Detach the breather hose (A), and on F models the vacuum valve hose (B) and the drain hose (C)



11.2a Pull the outer cable from the bracket . . .

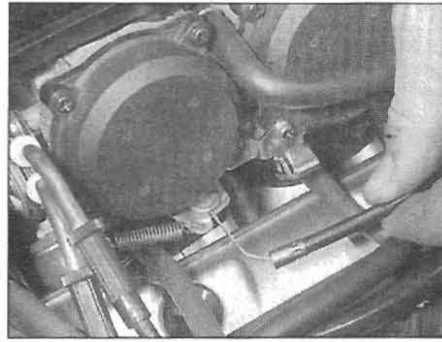

11.2b . . . and detach the cable end from the lever

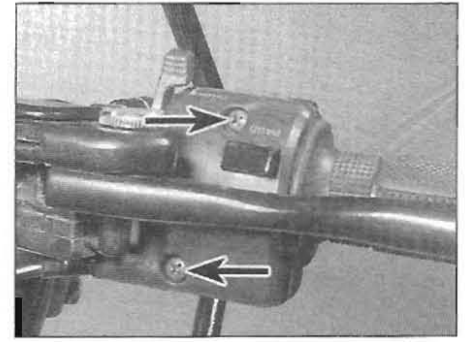

11.3a Remove the screws (arrowed) . . .



11.3b . . . and separate the halves

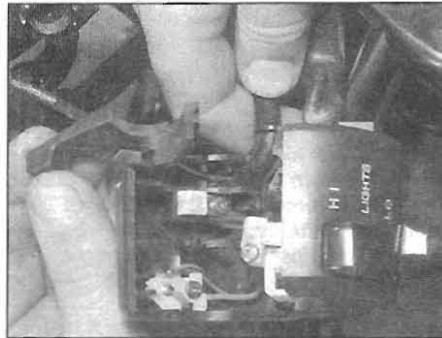

11.3c Remove the lever and elbow . . .

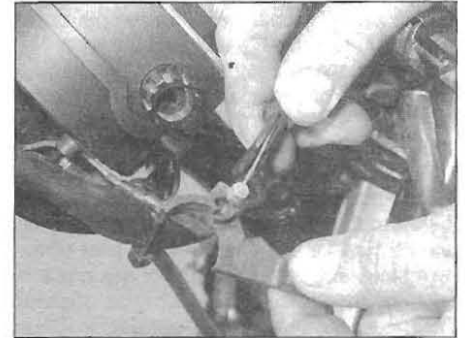

11.3d . . . and detach the cable

lock) and note whether idle speed increases. If it does, the cables are routed incorrectly. Correct this dangerous condition before riding the bike.

Throttle grip

Removal

13 Follow Steps 2 through 5 to detach the upper ends of the throttle cables from the throttle grip pulley.

14 Remove the grip end weight and slide the throttle grip off the handlebar.

Installation

15 Clean the handlebar and apply a light coat of multi-purpose grease.

16 Push the throttle grip on. Install the grip end weight and tighten the screw securely.

17 Reconnect the cables in a reverse of the dismantling order, then adjust them following the procedure outlined in Chapter 1, Section 18.

11 Choke cable – removal, installation and adjustment

Removal

1 Remove the fuel tank (see Section 2) and the air filter housing (see Section 4).

2 Pull the choke cable out of its mounting

bracket at the carburettor assembly, then pass the inner cable through the opening in the bracket and detach the cable end from the choke lever (see illustrations).

3 Remove the two screws securing the choke cable/switch housing halves to the left handlebar and separate the halves (see illustrations). Remove the choke lever and cable elbow from the housing, noting how they fit, and detach the cable end from the lever (see illustrations).

4 Remove the cable, noting how it's routed.

Installation

5 Route the cable into position. Connect the upper end of the cable to the choke lever (see illustration 11.3d). Make sure the cable guide and lever seat properly in the housing (see illustration 11.3c). Place the housing up against the handlebar, making sure the pin in the housing fits into the hole in the handlebar (see illustration 11.3b). Install the screws, tightening them securely.

6 Connect the lower end of the cable to the choke lever (see illustration 11.2b). Pull back on the cable and feed it into the bracket, making sure it seats correctly (see illustration 11.2a).

7 Install the air filter housing (see Section 4) and the fuel tank (see Section 2).

Adjustment

8 Follow the procedure outlined in Chapter 1, Section 18, to adjust the cables.

12 Air/fuel mixture adjustment – general information

Note: Due to the increased emphasis on controlling exhaust emissions in certain world markets, regulations have been formulated which prevent adjustment of the air/fuel mixture. On such models the pilot screw positions are pre-set at the factory and in some cases have a metal sealing plug pressed into the hole over the pilot screw to prevent tampering. Where adjustment is possible, it can only be made in conjunction with an exhaust gas analyser to ensure that the machine does not exceed emissions regulations.

1 If the engine runs extremely rough at idle or continually stalls, and if a carburettor overhaul does not cure the problem (and it definitely is a carburation problem – see Section 6), the pilot screws may require adjustment. It is worth noting at this point that unless you have the experience to carry this out it is best to entrust the task to a motorcycle dealer, tuner or fuel systems specialist. The pilot screws are located underneath the carburettors and are best accessed using a purpose-made angled screwdriver, available from any good accessory dealer. Make sure the valve clearances are correct and the carburettors are synchronised before adjusting the pilot screws (see Chapter 1).



6.2a IC igniter – F models

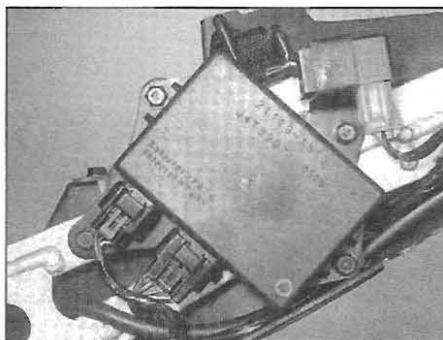

6.2b IC igniter – G and H models



6.2c IC igniter – J and A models

6 IC igniter – removal, check and installation



Removal

- 1 Remove the side panels (see Chapter 8). Make sure the ignition is switched OFF.
- 2 Unbolt the igniter and unplug the electrical connectors (see illustrations).

Check

3 The igniter is a delicate and expensive component requiring the use of a specific tester to check its condition. Take the machine to a Kawasaki dealer if the igniter is suspected of being faulty.

Installation

- 4 Plug in the electrical connectors, place the igniter in position, install the mounting bolts and tighten them securely.
- 5 Install the side panels (see Chapter 8).

7 Throttle position sensor (G, H, J and A models) – check and adjustment



Check

- 1 Before checking the sensor itself, check the idle speed and carburettor synchronisation (see Chapter 1).
- 2 Remove the fuel tank (see Chapter 4). Arrange a temporary fuel supply, either by using a small temporary tank or by using extra long fuel pipes to the now remote fuel tank, or position the tank on a suitable base on the motorcycle, taking care not to scratch any

paintwork, and making sure that the tank is safely and securely supported.

3 The throttle sensor is mounted on the outside of the right-hand carburettor (see illustration). Using a voltmeter, insert the positive probe into the back of the sensor wiring connector yellow/white wire terminal, and the negative probe into the black/blue wire terminal. If the probes cannot be inserted into the connector, disconnect it and prepare some auxiliary wires to run between the terminals of the connector and the sensor itself, with a small portion of the insulation cut away so that the meter probes can be connected to them using crocodile clips. Alternatively, and preferably, prepare two insulated terminals midway along each wire to accept the meter probes.

Caution: Do not allow the bare sections of wire to contact each other or any other part of the motorcycle. Make sure the wires connect between the correct terminals – do not get them crossed.

- 4 Start the engine and allow it to idle. Check the voltage output of the sensor and compare it to the output specified at the beginning of the Chapter, then stop the engine. If the recorded output differs from that specified, adjust the sensor position (see Step 6).
- 5 For a further test on J and A models, with the voltmeter connected as before, turn the ignition ON but do not start the engine. Open the throttle fully. If the output voltage is not as specified, fit a new sensor.

Adjustment

6 Unless an angled screwdriver is available, it will be necessary to displace the carburettors to access the screws (see Chapter 4). Slacken the sensor mounting screws and turn the ignition ON (see illustration 7.3). Rotate the sensor until the output is within the

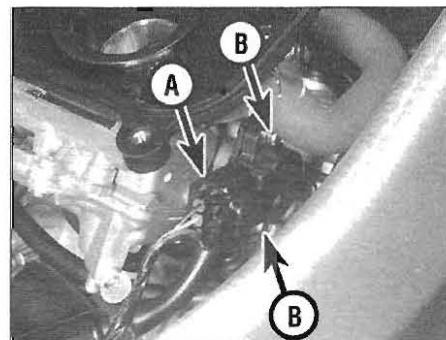

7.3 Throttle position sensor wiring connector (A) and mounting screws (B)

specified range, then tighten the screws evenly and a little at a time to the torque specified at the beginning of the Chapter. If it cannot be adjusted to within the range, see Step 8.

7 If no reading is obtained, disconnect the relevant ignition control module wiring connector and check the connectors for loose or corroded terminals. Test the wiring between the terminals of the sensor wiring connector and the corresponding terminals on the IC igniter connector for continuity. There should be continuity between each terminal. If not, this is probably due to a damaged or broken wire between the connectors; pinched or broken wires can usually be repaired. Also check the sensor for cracks and other damage.

8 If the sensor is suspected of being faulty, take the bike to a Kawasaki dealer for testing. If it is confirmed to be faulty, it must be renewed; the sensor is a sealed unit and cannot therefore be repaired. If the sensor is good, have the IC igniter checked by a Kawasaki dealer.

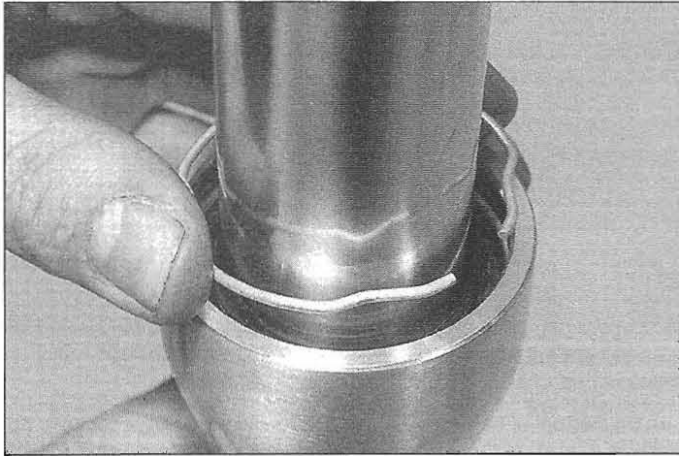

7.24 Install the retaining clip . . .

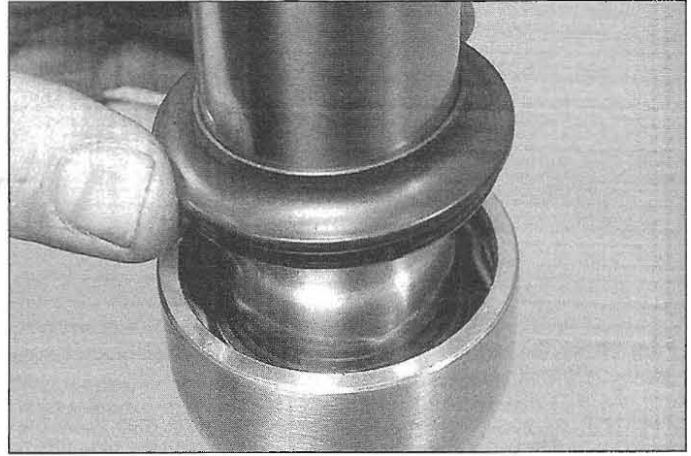

7.25 . . . followed by the dust seal



Place the old oil seal on top of the new one to protect it when driving the seal into place.

24 Once the seal is correctly seated, fit the retaining clip, making sure it is correctly located in its groove (see illustration).

25 Lubricate the lips of the new dust seal then slide it down the fork tube and press it into position (see illustration).

26 Clamp the fork slider upright in a vice. Slowly pour in the specified quantity and

grade of fork oil and pump the fork and damper cartridge rod at least ten times each to distribute it evenly (see illustration); the oil level should also be measured and adjustment made by adding or subtracting oil. Fully compress the fork tube and damper cartridge rod into the slider and measure the fork oil level from the top of the tube (see illustration). Add or subtract fork oil until it is at the level specified at the beginning of the Chapter.

27 Pull the fork tube and damper rod out of the slider as far as possible. If it was removed, thread the locknut onto the damper rod,

making sure the chamfered side of the nut is at the bottom. Set the nut so that on F models there is 12 mm of damper rod thread visible above the top of the nut, and on all other models so that there is 11 mm of thread visible.

28 Install the spring with its narrower end or closer-wound coils at the top on F models, and at the bottom on all other models (see illustration). Install the spring seat. On G, H, J and A models, install the spacer and the washer (see illustrations).

29 Insert the rebound damping adjuster rod into the centre of the damper cartridge rod

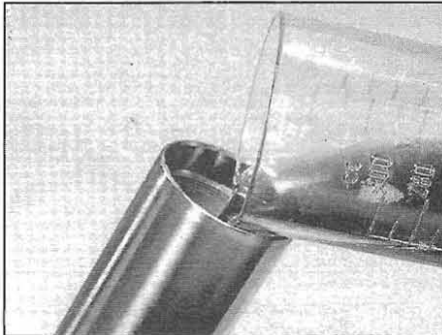

7.26a Pour the oil into the top of the tube

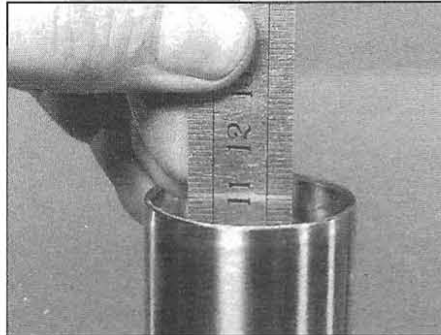

7.26b Measure the oil level with the fork held vertical

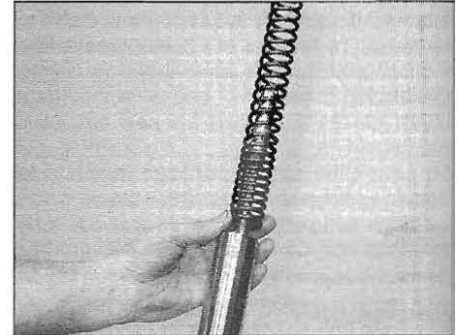

7.28a Install the spring . . .

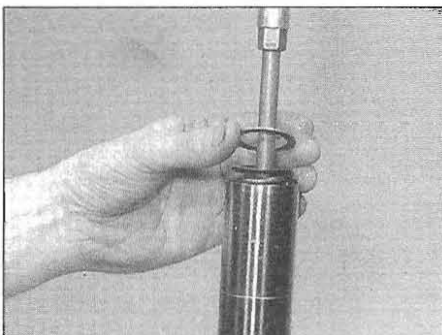

7.28b . . . followed by the spring seat . . .



7.28c . . . and on G, H, J and A models the spacer . . .

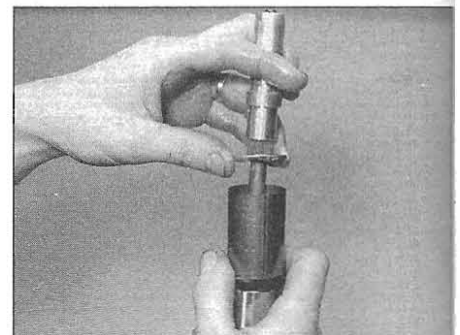

7.28d . . . and the washer

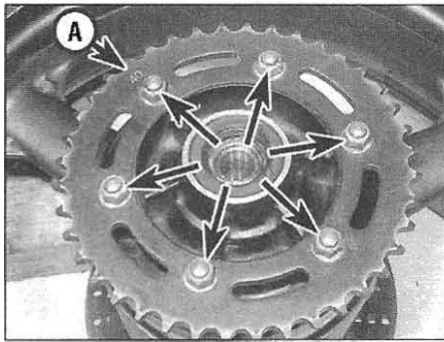

16.15 Unscrew the nuts (arrowed) and remove the sprocket, noting the tooth number marking (A)

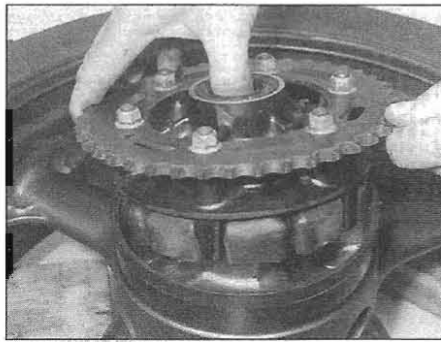

17.2 Lift the sprocket coupling out of the wheel . . .

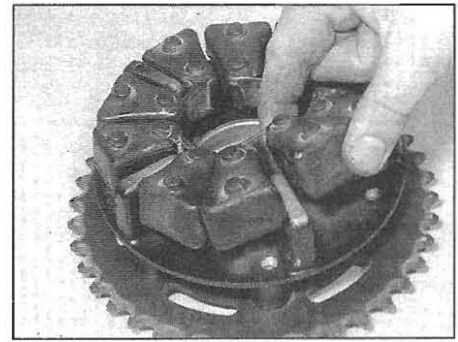

17.3 . . . and remove the damper

noting which way round it fits (see illustration).

16 Check that the sprocket studs are secure in the coupling. If any are loose, remove them all and clean their threads, then apply a suitable non-permanent thread locking compound and tighten them securely. To ease removal and tightening of the studs, thread two nuts onto the stud and use one as a locknut and the other to unscrew and tighten the studs (see *Tools and Workshop Tips* in the Reference section).

17 Install the sprocket onto the coupling with the stamped tooth number facing out, then fit

the nuts (see illustration 16.15). Tighten the nuts to the torque setting specified at the beginning of the Chapter.

18 Install the rear wheel (see Chapter 7), then adjust and lubricate the chain following the procedures described in Chapter 1.

17 Sprocket coupling/rubber damper – check and renewal



1 Remove the rear wheel (see Chapter 7).

2 Lift the sprocket coupling from the wheel (see illustration). Check the coupling for cracks and damage, and renew it if necessary.

3 Remove the rubber damper from the sprocket coupling or wheel hub and check it for cracks, hardening and general deterioration (see illustration). Fit a new damper if necessary.

4 Checking and renewal procedures for the coupling bearing are in Chapter 7.

5 Installation is the reverse of removal.

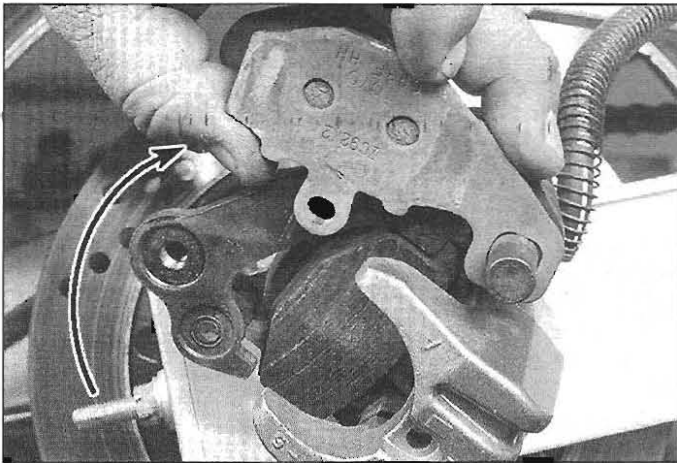

6.1c To remove the inner pad, pivot the free end up and slide the pad off the pin

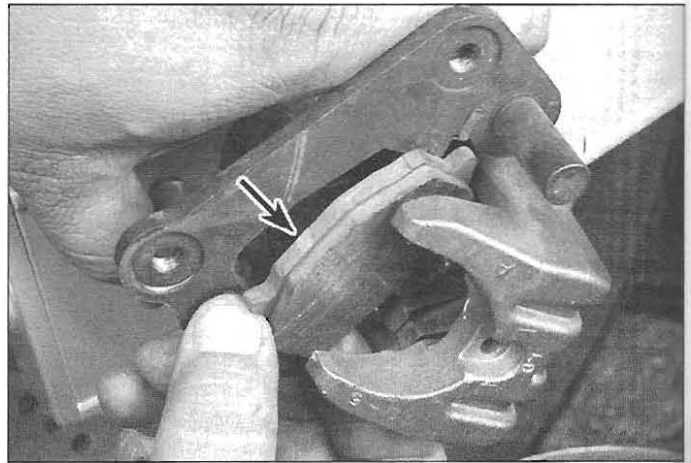

6.1d To remove the outer pad, push down on it (arrow) and pull the pad edge out from under the bracket

pad and slide it off its guide pin on the caliper mounting bracket, noting how it fits (see illustration). Remove the outer pad from the caliper body, noting how the pad locates against the guide and the bracket (see illustration).

2 Inspect the surface of each pad for contamination and check that the friction material has not worn level with or beyond the wear grooves in the pad face or the cutouts in the pad edge. If either pad is worn down to, or beyond, the service limit, fouled with oil or grease, or heavily scored or damaged by dirt and debris, both pads must be renewed as a set. Note that it is not possible to degrease the friction material; if the pads are contaminated in any way they must be discarded.

3 If the pads are in good condition clean them carefully, using a fine wire brush which is completely free of oil and grease to remove all traces of road dirt and corrosion. Using a pointed instrument, clean out the grooves in the friction material and dig out any embedded particles of foreign matter.

4 Check the condition of the brake disc (see Section 8).

5 Remove all traces of corrosion from the pad pin. Inspect the pin and the pin clip for signs of damage and renew them if necessary.

6 Push the pistons as far back into the caliper as possible using hand pressure or a piece of wood as leverage. Due to the increased friction material thickness of new pads, it may be necessary to remove the master cylinder reservoir cap, diaphragm plate and diaphragm and siphon out some fluid. If the piston is seized in the caliper, the caliper must be overhauled (see Section 7).

7 Smear the backs of the pads and the shank of the pad pin with copper-based grease, making sure that none gets on the friction material of the pads.

8 Installation of the pads is the reverse of removal. Make sure the pad spring and guide are correctly positioned. Insert the pads into the caliper so that the friction material faces the disc (see illustrations 6.1d and c). Make sure the outer pad locates correctly against the guide and the bracket (see illustration). Slide the pad pin through each pad and secure it with the clip (see illustrations 6.1b and a).

9 Install the caliper on the brake disc making sure the pads sit squarely either side of the disc.

10 Install the caliper mounting bolts, and tighten them to the torque setting specified at the beginning of this Chapter (see illustration 7.1).

11 Top up the master cylinder reservoir if necessary (see *Daily (pre-ride) checks*), and install the reservoir diaphragm, diaphragm plate and cap.

12 Operate the brake pedal several times to bring the pads into contact with the disc. Check the operation of the brake before riding the motorcycle.

7 Rear brake caliper – removal, overhaul and installation



Warning: If a caliper indicates the need for an overhaul (usually due to leaking fluid or sticky operation), all old brake fluid

should be flushed from the system. Also, the dust created by the brake system may contain asbestos, which is harmful to your health. Never blow it out with compressed air and don't inhale any of it. An approved filtering mask should be worn when working on the brakes. Do not, under any circumstances, use petroleum-based solvents to clean brake parts. Use clean brake fluid, brake cleaner or denatured alcohol only.

Removal

1 If the caliper is just being displaced and not completely removed or overhauled, do not disconnect the brake hose. If the caliper is being overhauled, remove the brake hose banjo bolt (see illustration). Note the alignment of the hose on the caliper and separate the hose from the caliper. Wrap a plastic bag tightly around the hose end to minimise fluid loss and prevent dirt entering the system, and secure the hose in an upright position. Discard the sealing washers as new ones must be used on installation. **Note:** If you are planning to overhaul the caliper and don't have a source of compressed air to blow out the piston, just loosen the banjo bolt at this stage and retighten it lightly. The bike's

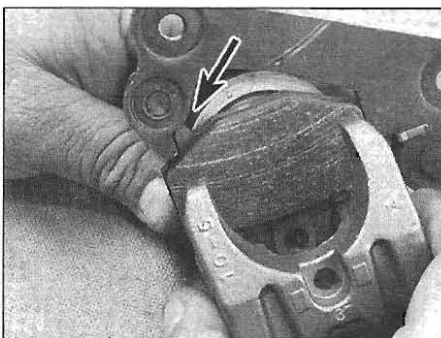

6.8 Make sure the outer pad locates correctly against the bracket (arrowed)

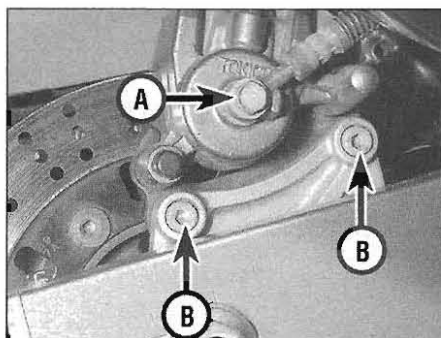

7.1 Brake hose banjo bolt (A), caliper mounting bolts (B)

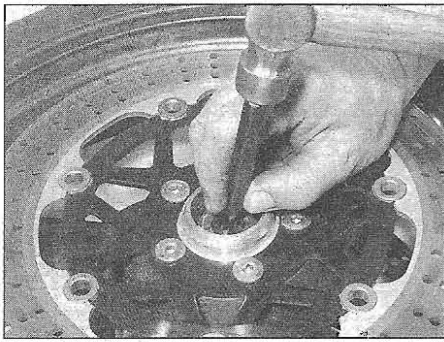

16.5a Drive out the bearing using a drift and hammer as shown

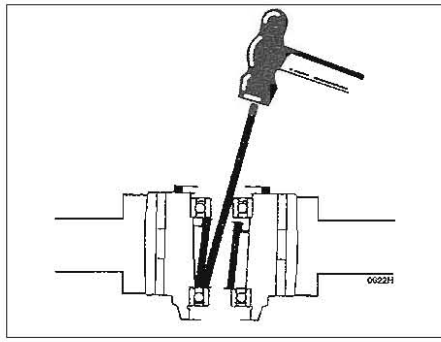

16.5b Locate the drift as shown when driving out the bearing

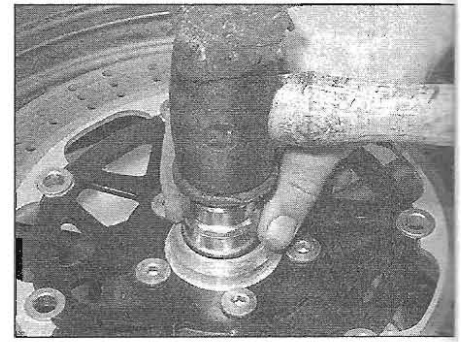

16.10 Drive the bearing in as described

4 On G, H, J and A models, lever out the grease seal on each side of the wheel using a flat-bladed screwdriver, taking care not to damage the rim (see illustration 16.3c). Remove the circlip securing the right-hand bearing (see illustration 16.3d).

HAYNES HINT Position a piece of wood against the wheel to prevent the screwdriver shaft damaging it when levering the grease seals out.

5 Using a metal rod (preferably a brass drift punch) inserted through the centre of the one bearing, tap evenly around the inner race of the other bearing to drive it from the hub (see illustrations). The bearing spacer will also come out.

6 Lay the wheel on its other side so that the remaining bearing faces down. Drive the bearing out of the wheel using the same technique as above.

7 If the bearings are of the unsealed type or are only sealed on one side, clean them with a high flash-point solvent (one which won't leave any residue) and blow them dry with compressed air (don't let the bearings spin as you dry them). Apply a few drops of oil to the bearing. **Note:** If the bearing is sealed on both sides don't attempt to clean it.

Refer to Tools and Workshop Tips (Section 5) for more information about bearings.

8 Hold the outer race of the bearing and rotate the inner race – if the bearing doesn't turn smoothly, has rough spots or is noisy, fit a new one.

9 If the bearing is good and can be re-used,

wash it in solvent once again and dry it, then pack the bearing with grease.

10 Thoroughly clean the hub area of the wheel. Install the right-hand bearing into its recess in the hub, with the marked or sealed side facing outwards. Using the old bearing (if new ones are being fitted), a bearing driver or a socket large enough to contact the outer race of the bearing, drive it in until it's completely seated – the circlip groove should be completely exposed (see illustration). Fit the circlip, making sure it seats properly in its groove (see illustration 16.3d).

11 Turn the wheel over and install the bearing spacer. Drive the left-hand bearing into place as described above.

12 Apply a smear of grease to the lips of the seal(s), then press them into the wheel (see illustration), using a seal or bearing driver, a suitable socket or a flat piece of wood to drive it into place if necessary (see illustration 16.22). On F models, fit the speedometer drive collar into the left-hand side of the wheel, aligning the tabs on the collar with the cutouts in the hub (see illustration 16.3b). Secure the collar with the circlip, making sure it seats properly in its groove (see illustration 16.3a).

13 Clean off all grease from the brake discs using acetone or brake system cleaner then install the wheel (see Section 14).

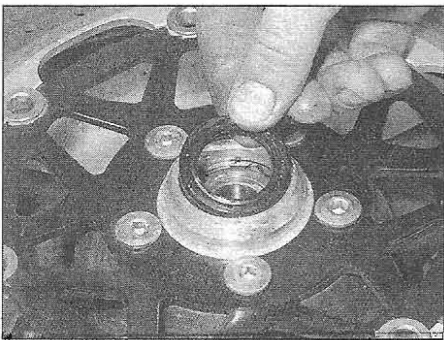

16.12 Fit the grease seal as described

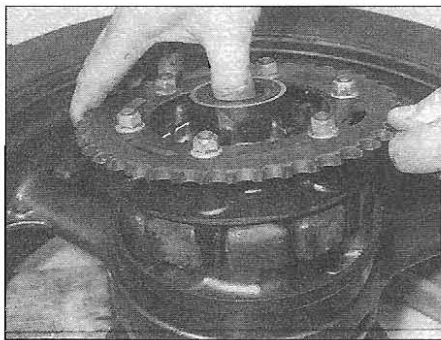

16.14 Lift the sprocket coupling out of the wheel

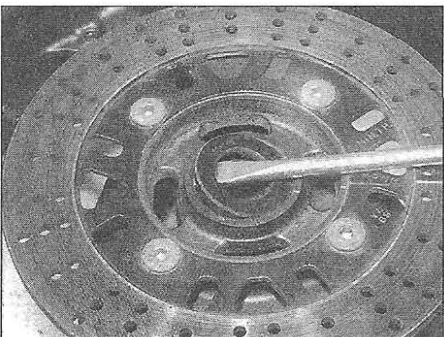

16.16a Lever out the grease seal . . .

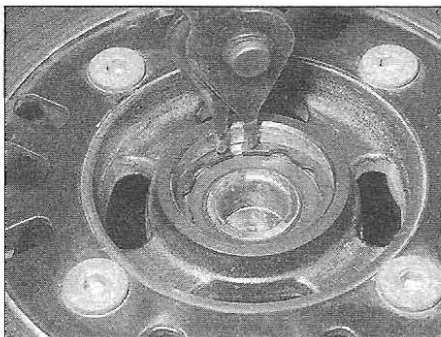

16.16b . . . and remove the circlip

Rear wheel bearings

14 Remove the rear wheel (see Section 15). Lift the sprocket coupling out of the wheel, noting how it fits (see illustration).

15 Set the wheel on blocks so as not to allow the weight of the wheel to rest on the brake disc.

16 Lever out the grease seal on the right-hand side of the wheel using a flat-bladed screwdriver, taking care not to damage the rim of the hub (see illustration). Discard the seal as a new one should be used. Remove the circlip securing the right-hand bearing (see illustration).

17 Using a metal rod (preferably a brass drift punch) inserted through the centre of one bearing, tap evenly around the inner race of the other bearing to drive it from the hub (see

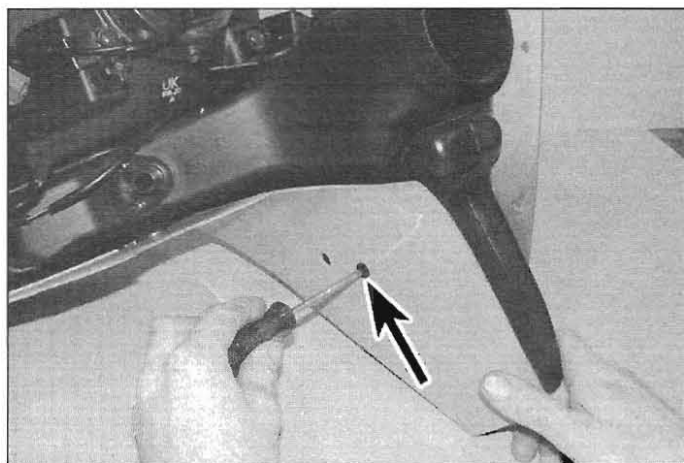

9.2a Undo the screw (arrowed) on each side of the upper fairing . . .



9.2b . . . and lift out the ducts

9 Air intake (J and A models) – removal and installation



2 Undo the screws securing the left and right-hand air intake ducts to the fairing and lift out the ducts (see illustrations).

3 Unscrew the two trim clips on the underside of the fairing and the trim clip on the underside of the headlight unit, then pull out the intake grille (see illustrations).

Installation

4 Installation is the reverse of removal. Before fitting the trim clips, ensure the locating holes are correctly aligned. Press the clip tabs together then insert the clip into the hole. Press the trim clip in firmly, then push the clip centre in to lock the clip in place.

Removal

1 Remove the upper fairing (see Section 5).

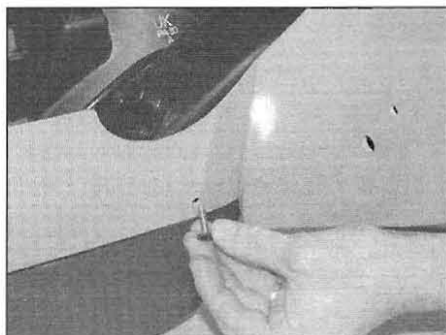

9.3a Unscrew the left and right-hand trim clips . . .



9.3b . . . and the trim clip under the headlight unit . . .



9.3c . . . then pull out the intake grille

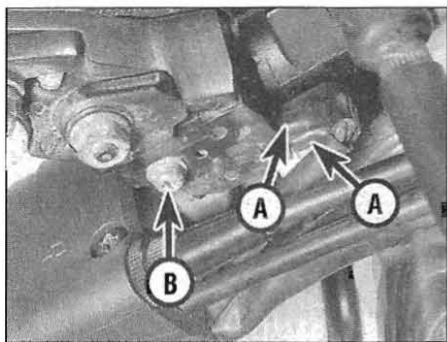

14.6 Front brake light switch wiring connectors (A) and mounting screw (B)

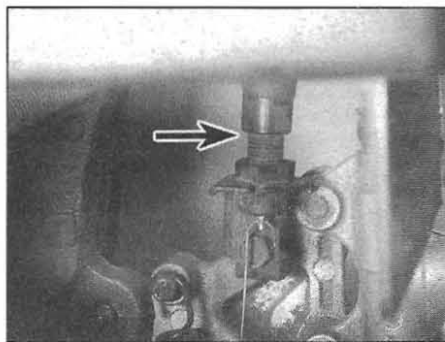

14.9a Rear brake light switch (arrowed)

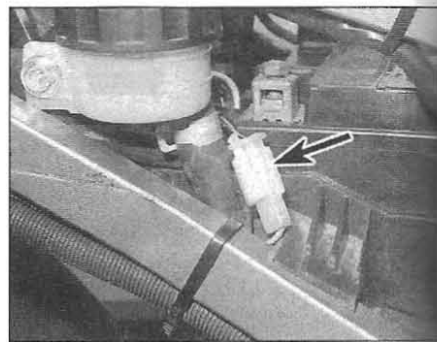

14.9b Disconnect the brake light switch wiring connector

Switch renewal

Front brake lever switch

6 The switch is mounted on the underside of the brake master cylinder. Disconnect the wiring connectors from the switch (see illustration).

7 Remove the single screw securing the switch to the bottom of the master cylinder and remove the switch (see illustration 14.6).

8 Installation is the reverse of removal. The switch isn't adjustable.

Rear brake pedal switch

9 The switch is mounted on the inside of the right-hand footrest bracket (see illustration). Remove the seat for access to the connector (see Chapter 8). Trace the wiring from the

switch and disconnect it at the connector (see illustration).

10 Detach the lower end of the switch spring from the brake pedal, then unscrew and remove the switch. If access to the switch is too restricted, unscrew the two bolts securing the rider's right-hand footrest bracket to the frame, then swing the whole footrest/rear brake master cylinder assembly out, making sure no strain is placed on the brake and reservoir hoses.

11 Installation is the reverse of removal. If removed, tighten the footrest bracket bolts securely. Make sure the brake light is activated just before the rear brake pedal takes effect. If adjustment is necessary, hold the switch and turn the adjusting ring on the switch body until the brake light is activated when required.

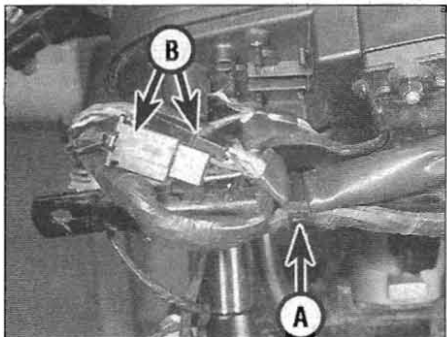

15.3a On F models, cut the cable tie (A) and disconnect the wiring connectors (B)

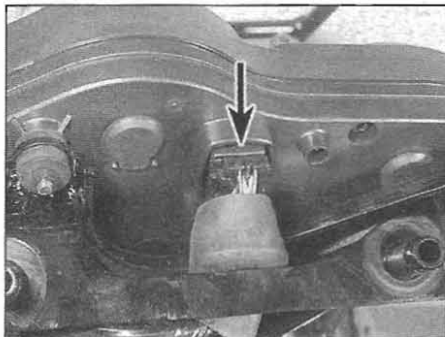

15.3b On G and H models, pull back the rubber boot and disconnect the wiring connector (arrowed)



15.3c Wiring connector on J and A models

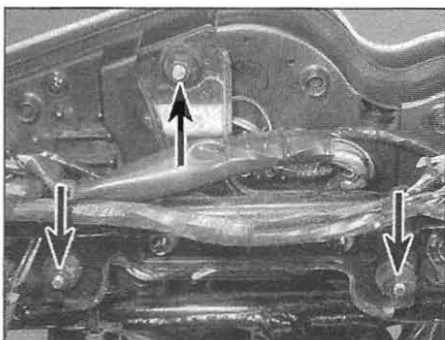

15.4a Instrument cluster mounting nuts (arrowed) - F models

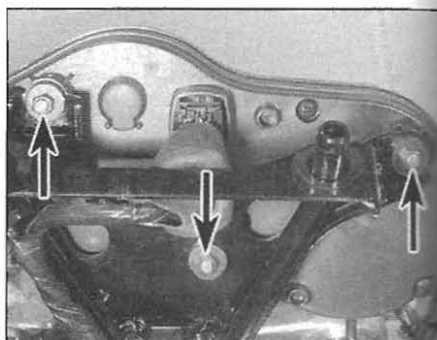

15.4b Instrument cluster mounting nuts (arrowed) - G and H models

15 Instrument cluster and speedometer cable - removal and installation

Instrument cluster

Removal

1 On F models, remove the upper fairing (see Chapter 8). On G, H, J and A models, it is only necessary to remove the windshield (see Chapter 8), though it is advisable to remove the entire upper fairing to avoid the possibility of damaging it should a spanner slip when unscrewing the nuts securing the cluster.

2 On F models, unscrew the knurled ring securing the speedometer cable to the back of the speedometer and detach the cable (see illustration 15.8).

3 On F models, cut the cable tie securing the cluster wiring and disconnect the wiring connectors (see illustration). On G, H, J and A models, draw back the rubber boot and disconnect wiring connector from the cluster (see illustrations). On G and H models, if the connector is tight and difficult to pull off, disconnect it after displacing the cluster from its bracket.

4 Unscrew the three nuts securing the instrument cluster and carefully lift it away (see illustrations).

Caution: Do not store the instrument cluster on its face or side - keep it the right way up or it could be damaged.

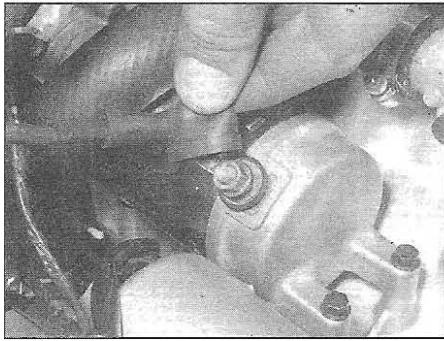

28.2a Pull back the rubber cover . . .

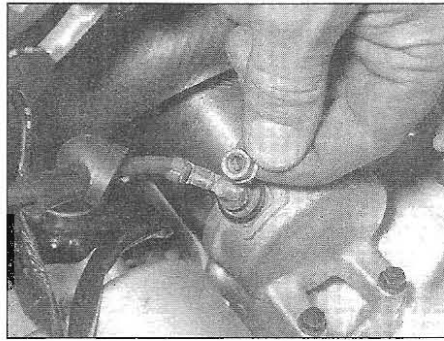

28.2b . . . then unscrew the nut and detach the lead

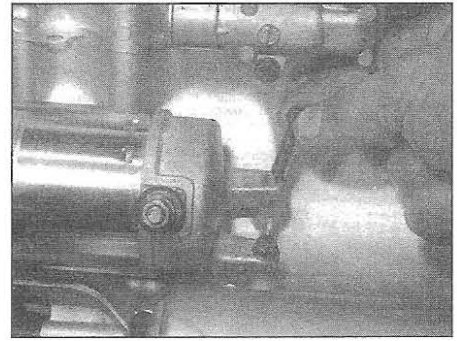

28.3 Unscrew the bolts and remove the starter motor

then remove the nut securing the starter lead to the motor and detach the lead (see illustrations).

3 Unscrew the two bolts securing the starter motor to the crankcase (see illustration). Slide the starter motor out from the crankcase and remove it from the machine.

4 Remove the O-ring on the end of the starter motor and discard it as a new one must be used (see illustration).

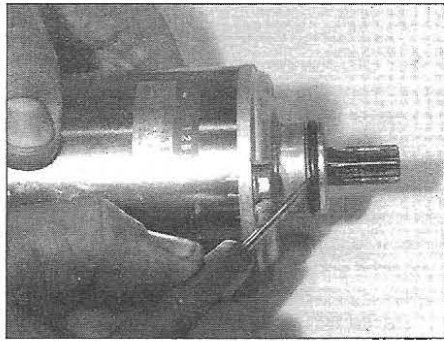

28.4 Remove the old O-ring and fit a new one

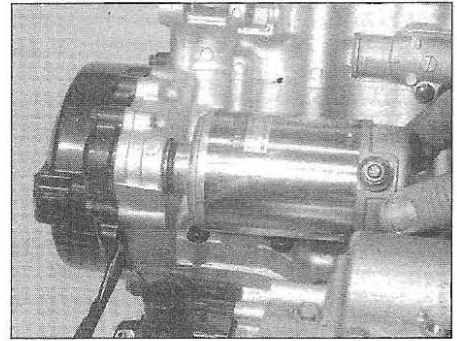

28.6 Slide the motor into the crankcase

Installation

5 Install a new O-ring on the end of the starter motor and ensure it is seated in its groove (see illustration 28.4). Apply a smear of engine oil or grease to the O-ring to aid installation. Make sure the mating surfaces between the starter motor mounting lugs and the crankcase are clean to ensure a good earth (ground) contact.

6 Manoeuvre the motor into position and slide it into the crankcase (see illustration). Ensure that the starter motor teeth mesh correctly with those of the starter idle/reduction gear. Install the mounting bolts and tighten them to the torque setting specified at the beginning of the Chapter (see illustration 28.3).

7 Connect the starter lead to the motor and secure it with the nut (see illustrations 28.2b and a). Make sure the rubber cover is correctly seated over the terminal.

8 Install the seats (see Chapter 8).

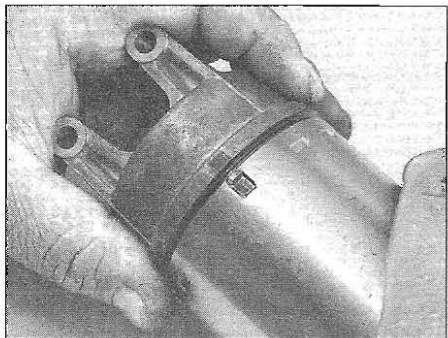

29.2 Mark the relationship of the end covers to the main housing

29 Starter motor – disassembly, inspection and reassembly

Disassembly

F models

- 1 Remove the starter motor (see Section 28).
- 2 Note the alignment marks between the main housing and the front and rear covers, or make your own if they aren't clear (see illustration).
- 3 Unscrew the two long bolts and withdraw them from the starter motor. Discard their O-rings as new ones must be used.
- 4 Remove the front cover from the motor. Remove the cover O-ring from the main housing and discard it as a new one must be used.

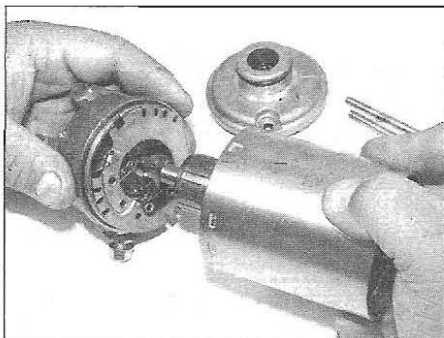

29.5 Carefully separate the rear cover from the main housing

5 Remove the rear cover and brushplate assembly from the motor, making sure that the brushes do not get caught up and damaged on the commutator (see illustration). Remove the cover O-ring from the main housing and discard it as a new one must be used. Remove the washer from the rear end of the armature shaft or from inside the rear cover after the brushplate assembly has been removed.

6 Withdraw the armature from the main housing.

7 Noting the correct fitted location of each component, unscrew the terminal nut from the rear cover and remove it along with the insulating rubber and O-ring. Remove the brushplate assembly and withdraw the terminal bolt from the main housing (see illustration).

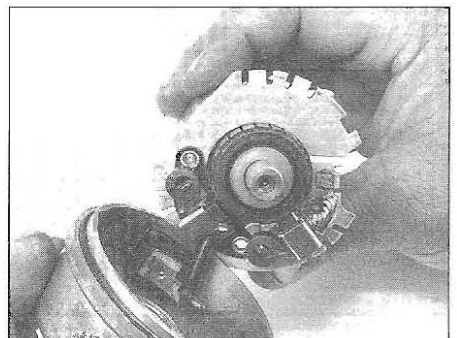

29.7 Remove the brushplate and terminal bolt from the rear cover

CLICK HERE TO **DOWNLOAD** THE COMPLETE MANUAL

- Thank you very much for reading the preview of the manual.
- You can download the complete manual from: www.heydownloads.com by clicking the link below



- Please note: If there is no response to CLICKING the link, please download this PDF first and then click on it.

CLICK HERE TO **DOWNLOAD** THE COMPLETE MANUAL