

JZ140 ZTS

[Section 1 - General Information](#)

[Section 2 - Care and Safety](#)

[Section 3 - Maintenance](#)

[Section B - Body and Framework](#)

[Section C - Electrics](#)

[Section E - Hydraulics](#)

[Section F - Transmissions](#)

[Section J - Track and Running Gear](#)

[Section K - Engine](#)



Publication No.
9803/6530-1



Copyright © 2004 JCB SERVICE. All rights reserved. No part of this publication may be reproduced, stored in a retrieval system, or transmitted in any form or by any other means, electronic, mechanical, photocopying or otherwise, without prior permission from JCB SERVICE.

Issued by JCB Technical Publications, JCB Service, World Parts Centre, Beamhurst, Uttoxeter, Staffordshire, ST14 5PA, England.
Tel +44 1889 590312 Fax +44 1889 593377

World Class
Customer Support

CLICK HERE TO **DOWNLOAD** THE COMPLETE MANUAL

- Thank you very much for reading the preview of the manual.
- You can download the complete manual from: www.heydownloads.com by clicking the link below



- Please note: If there is no response to CLICKING the link, please download this PDF first and then click on it.

CLICK HERE TO **DOWNLOAD** THE COMPLETE MANUAL

Service Tools

Numerical List Section B - Body and Framework

The tools listed in the table are special tools required for removal and replacement of Body and Framework parts. These tools are available from JCB Service.

Tools other than those listed will be required. It is expected that such general tools will be available in any well equipped workshop or be available locally from any good tool supplier.

Part Number	Description	Tool Detail Reference
4104/1310	Hand Cleaner	Fig 1. (🔗) 1-10
826/01099	M6 x 16mm Rivet Nut	Fig 2. (🔗) 1-10
826/01101	M6 x 19mm Rivet Nut	Fig 2. (🔗) 1-10
826/01102	M8 x 21mm Rivet Nut	Fig 2. (🔗) 1-10
826/01103	M8 x 18mm Rivet Nut	Fig 2. (🔗) 1-10
826/01104	M10 x 23mm Rivet Nut	Fig 2. (🔗) 1-10
826/01105	M10 x 26mm Rivet Nut	Fig 2. (🔗) 1-10
892/00842	Glass Lifter	Fig 3. (🔗) 1-10
892/00843	Folding Stand for Holding Glass	Fig 4. (🔗) 1-10
892/00844	Long Knife	Fig 5. (🔗) 1-11
892/00845	Cartridge Gun	Fig 6. (🔗) 1-11
892/00846	Glass Extractor (Handles)	Fig 7. (🔗) 1-11
892/00847	Nylon Spatula	Fig 8. (🔗) 1-11
892/00848	Wire Starter	Fig 9. (🔗) 1-11
892/00849	Braided Cutting Wire	Fig 10. (🔗) 1-11
926/15500	Rubber Spacer Blocks	Fig 11. (🔗) 1-12
992/12300	12V Oven	Fig 12. (🔗) 1-12
992/12400	240V Oven 2 Cartridge	Fig 13. (🔗) 1-12
992/12600	240V Oven 6 Cartridge	Fig 13. (🔗) 1-12
992/12800	Cut-Out Knife	Fig 14. (🔗) 1-12
992/12801	'L' Blades	Fig 15. (🔗) 1-12

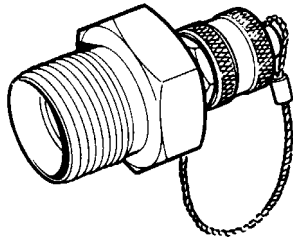

Fig 23. Pressure Test Adapters

892/00255 1/4 in BSP x Test Point
892/00256 3/8 in BSP x Test Point
892/00257 1/2 in BSP x Test Point
892/00258 5/8 in BSP x Test Point
816/15118 3/4 in BSP x Test Point
892/00259 1 in BSP x Test Point
892/00260 1,1/4 in BSP x Test Point
892/00261 5/8 in UNF x Test Point

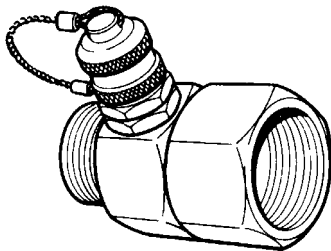

Fig 24. Pressure Test 'T' Adapters

892/00262 1/4 in BSP x 1/4 in F BSP x Test Point
816/55040 1/2 in BSP x 1/2 in F BSP x Test Point
892/00263 5/8 in BSP x 5/8 in F BSP x Test Point
892/00264 3/4 in BSP x 3/4 in F BSP x Test Point
892/00265 1 in M BSP x 1 in F BSP x Test Point
892/00266 1,1/4 in M BSP x 1,1/4 in F BSP x Test Point
892/00267 1,1/2 in M BSP x 1,1/2 in F BSP x Test Point

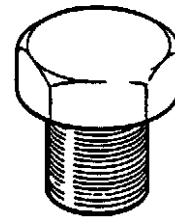

Fig 25. Female Cone Blanking Plug

892/00055 - 1/4 in BSP
892/00056 - 3/8 in BSP
892/00057 - 1/2 in BSP
892/00058 - 5/8 in BSP
892/00059 - 3/4 in BSP
892/00060 - 1 in BSP

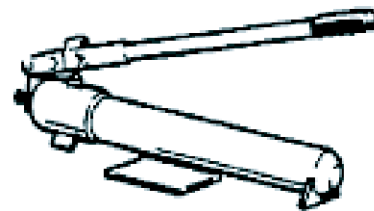

Fig 26. 892/00223

Note: Components listed below also required

Item	Description
1	892/00137 Micro-bore Hose 1/4 in BSP x 5 metres
2	892/00274 Adapter 1/4 in M BSP x 3/8 in M BSP Taper
3	892/00262 1/4 in M BSP x 1/4 in F BSP x Test Point
4	892/00706 Test Probe
5	892/00278 Gauge 0 - 40 bar (0 - 600 lb/in ²)
6	892/00279 Gauge 0 - 400 bar (0 - 6000 lb/in ²)
7	892/00280 Gauge 0 - 600 bar (0 - 8500 lb/in ²)

Service Consumables

Sealing and Retaining Compounds

T11-001_2

Table 1.

Type	Description	Part No.	Quantity
JCB Multi-Gasket	A medium strength sealant suitable for all sizes of gasket flanges, and for hydraulic fittings of 25-65 mm diameter.	4102/1212	50 ml
JCB High Strength Threadlocker	A high strength locking fluid for use with threaded components. Gasketing for all sizes of flange where the strength of the joint is important.	4102/0551	50 ml
JCB Retainer (High Strength)	For all retaining parts which are unlikely to be dismantled.	4101/0651	50 ml
JCB Threadlocker and Sealer	A medium strength locking fluid for sealing and retaining nuts, bolts, and screws up to 50 mm diameter, and for hydraulic fittings up to 25 mm diameter.	4101/0250	10 ml
		4101/0251	50 ml
JCB Threadlocker and Sealer (High Strength)	A high strength locking fluid for sealing and retaining nuts, bolts, and screws up to 50 mm diameter, and for hydraulic fittings up to 25 mm diameter.	4101/0550	10 ml
		4101/0552	200 ml
JCB Threadseal	A medium strength thread sealing compound.	4102/1951	50 ml
JCB Activator	A cleaning primer which speeds the curing rate of anaerobic products.	4104/0251	200 ml (Aerosol)
		4104/0253	1 ltr (Bottle)
JCB Cleaner/Degreaser	For degreasing components prior to use of anaerobic adhesives and sealants.	4104/1557	400 ml (Aerosol)
Anti-Seize Paste	A compound used for assembly and prevention of parts seizure.	4003/0211	
Direct Glazing Kit	For one pane of glass; comprises of: <ul style="list-style-type: none"> - 1 x Ultra Fast Adhesive (310 ml) - 1 x Active Wipe 205 (30 ml) - 1 x Black Primer 206J (30 ml) - plus applicator nozzle etc. 	993/55700	
Ultra Fast Adhesive	For direct glazing.	4103/2109	310 ml
Active Wipe 205	For direct glazing.	4104/1206	30 ml
		4104/1203	250 ml
Black Primer 206J	For direct glazing.	4201/4906	30 ml
Clear Silicone Sealant	To seal butt jointed glass.	4102/0901	
Plastic to Metal Bonder	To seal plastic to metal joints.	4103/0955	
Black Polyurethane Sealant	To finish exposed edges of laminated glass.	4102/2309	310 ml

Safety Decals

WARNING

Decals

Decals on the machine warn you of particular hazards. You can be injured if you do not obey the decal safety instructions.

Each decal is attached close to a part of the machine where there is a possible hazard. Make sure replacement parts include warning decals where necessary.

Keep all decals clean and readable. Replace lost or damaged decals. Each decal has a part number printed on it, use this number to order a new decal from your JCB distributor.

INT-3-3-3_1

WARNING

If you need eye-glasses for reading, make sure you wear them when reading the safety decals. Decals are strategically placed around the machine to remind you of possible hazards. Do not over-stretch or place yourself in dangerous positions to read the decals.

INT-3-3-4_1

WARNING

Electrical Circuits

Understand the electrical circuit before connecting or disconnecting an electrical component. A wrong connection can cause injury and/or damage.

INT-3-1-4

DANGER

Electrolyte

Battery electrolyte is toxic and corrosive. Do not breathe the gases given off by the battery. Keep the electrolyte away from your clothes, skin, mouth and eyes. Wear safety glasses.

INT-3-2-1_3

CAUTION

Damaged or spent batteries and any residue from fires or spillage should be put in a closed acid proof receptacle and must be disposed of in accordance with local environmental waste regulations.

INT-3-1-12

WARNING

Battery Gases

Batteries give off explosive gases. Keep flames and sparks away from the battery. Do not smoke close to the battery. Make sure there is good ventilation in closed areas where batteries are being used or charged. Do not check the battery charge by shorting the terminals with metal; use a hydrometer or voltmeter.

INT-3-1-8

Cleaning the Machine

Exterior

Clean the exterior of the machine using water and/or steam.

If steam is used the machine must be completely greased afterwards. See [Greasing \(↻\) 24](#)

Pay particular attention to the cab windows. Make sure that the radiator grille is not blocked.

Do not allow mud to build up on the tracks and running gear. See [Tracks and Running Gear \(↻\) 55](#)

Interior

CAUTION

Never use water or steam to clean inside the cab. The use of water or steam could damage the on-board computer and render the machine inoperable. Remove dirt using a brush or damp cloth.

8-3-4-8

Greasing

General Notes

For the type of grease to use at each point, see [Lubricants and Capacities \(12\)](#).

Do not mix different types of grease. Keep them separate.

WARNING

You will be working close into the machine for these jobs. Lower the attachments if possible. Remove starter key and disconnect the battery. This will prevent the engine being started.

8-3-1-3

Slew Ring Bearing

There are two grease nipples on the front of the machine and one on the front of the ring.

Slew Ring Teeth and Slew Pinion

Ensure slew ring is kept full of grease. Always grease whenever the machine has been steam-cleaned.

For location of the slew ring gear refer to Identification of Machine Components.

- 1 Make the Machine Safe. Stop the engine and remove the starter key.
- 2 Grease the Slew Ring.
 - a Remove the inspection port cover **A** (on the lower centre section).
 - b Remove the grease discharge port cover **B** (on the lower inner side).
 - c Remove contaminated grease.
 - d Replace the discharge port cover.
 - e Apply grease to the slew ring via aperture **C**.

- 3 Slew the Machine.

Start the engine and slew the machine a few degrees. Stop the engine, remove the starter key and apply grease again.

Repeat until the whole ring is greased. Check that grease exudes around the entire circumference.

- 4 Refit the Cover.

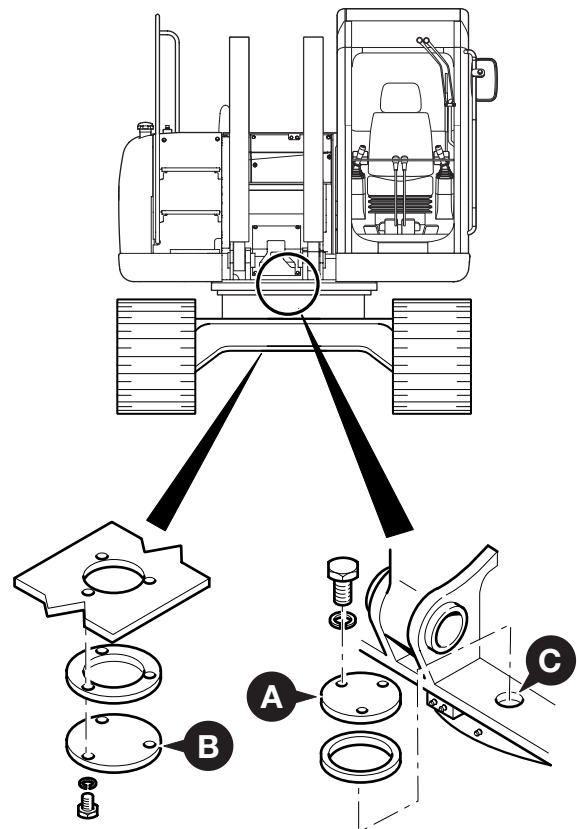

Fig 7.

Changing the Inner Air Filter Element

Note: Do not attempt to wash or clean the elements - they must only be renewed.

Note: Do not run the engine with the dust valve **F** removed.

Note: Change the outer element more frequently if operating in dusty conditions. A new inner element must be fitted at least every third time the outer element is changed. As a reminder, mark the inner element with a felt tipped pen each time the outer element is changed.

- 1 Stop the engine.
- 2 Press clips **A** and lift off cover **B**. Remove outer element **C**.
- 3 Lift up pulls **J** and remove inner element **G**.
- 4 Clean the inside of cover **B** and canister **D**.
- 5 Carefully insert the new inner element **G** into the canister. Make sure it seats correctly. Check seal **H** is fully seated.
- 6 Insert a new outer element **C** into the canister, check seal **E** is fully seated. Fit cover **B** with dust valve **F** at the bottom. Push the cover firmly into position and make sure it is secured by clips **A**.
- 7 Make sure that the wire is connected to the Air Filter Blocked switch.
- 8 Check all hoses for condition and tightness.

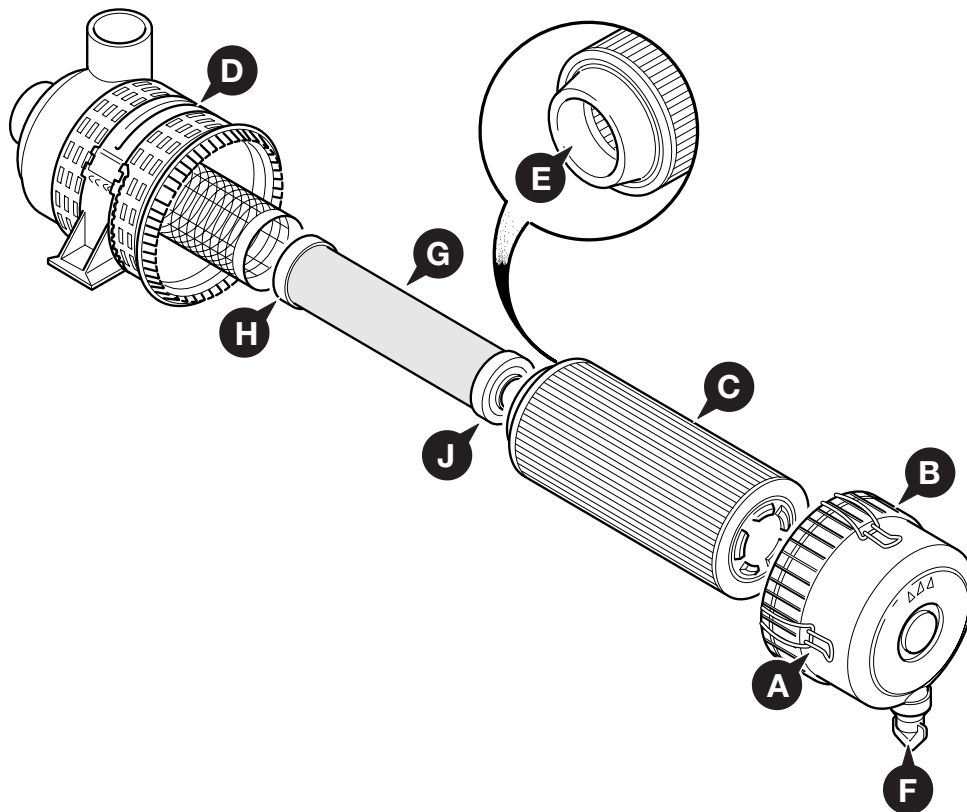

Fig 25.

Hydraulic System

⚠ WARNING

The temperature of the hydraulic oil will be high soon after stopping the engine. Wait until it cools (less than 40°C) before beginning maintenance.

8-3-4-10

⚠ WARNING

Fluid Under Pressure

Fine jets of fluid at high pressure can penetrate the skin. Keep face and hands well clear of fluid under pressure and wear protective glasses. Hold a piece of cardboard close to suspected leaks and then inspect the cardboard for signs of fluid. If fluid penetrates your skin, get medical help immediately.

INT-3-1-10_2

Checking the Fluid Level

- 1 Prepare the Machine. Position the machine on level ground with the bucket and dipper rams fully extended and the boom lowered to rest the attachment on the ground, as at **A**.
- 2 Check the Level. Look at the fluid level in the sight tube **B**. The level should be between the two marks on the tube. If the fluid is cloudy, water or air has entered the system.

Water or air in the system could damage the hydraulic pump. Contact your JCB distributor if the fluid is cloudy.

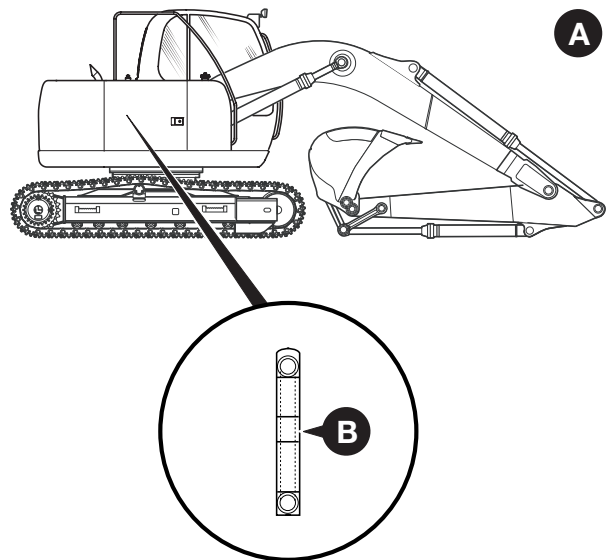

Fig 34.

Travel Gearbox

Checking the Track Gearbox Oil Level

- 1 Prepare the Machine.

Position the machine on level ground with the level and drain plugs as illustrated, see [Fig 48.](#) (↗ 54).

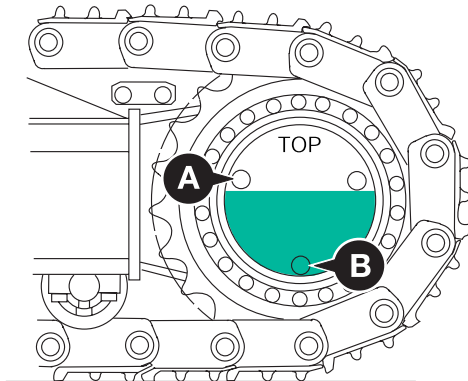

Fig 48.

- 2 Check the Level on One Side.

Clean the area around filler/level plug **A** and remove it. Oil should be level with plug **A**. Top up through plug **A** if necessary. See [Lubricants and Capacities](#) (↗ 12) for oil types.

- 3 Clean and Refit the Plug. Make sure it is tight.
- 4 Check the Level on the Other Side.

Repeat steps 1 to 3.

Changing the Track Gearbox Oil

- 1 Prepare the Machine. See [Checking the Track Gearbox Oil Level](#) (↗ 54)
- 2 Drain the Oil on One Side.
 - a Place a container below the drain plug to catch the oil. The container must be large enough to hold the maximum gearbox capacity (see [Lubricants and Capacities](#) (↗ 12))

CAUTION

Oil will gush from the hole when the drain plug is removed. Keep to one side when you remove the plug.

2-3-4-2

- b Remove filler/level plug **A** and drain plug **B**. Allow the oil to drain out.
 - c Wipe the plugs clean. Make sure you remove all metal particles.
 - d Wrap seal tape on the drain plug **B** and refit.
- 3 Fill with New Oil. See [Lubricants and Capacities](#) (↗ 12) for oil type and volume.
 - a Pour new oil through filler/level plug **A** until oil runs out of plug **A**.
 - b Check the condition of the o-ring, renew if it is damaged. Refit filler/level plug.
- 4 Change the Oil on the Other Side.

Repeat steps 1 to 3.
- 5 Check for Leaks.

Run the machine, operate the tracking controls and then make sure there are no leaks.

Table 24. Alternator

Message	Cause	Remedy
ALTERNATOR 	Belt tension	Adjust
	Wiring fault	Repair
	Defective battery	Replace
	Defective regulator	Replace ⁽¹⁾
	Defective alternator	Repair or replace ⁽¹⁾

Table 25. Low coolant

Message	Cause	Remedy
LOW COOLANT 	Coolant low	Refill
	Defective sensor	Replace ⁽¹⁾

Table 26. Engine oil filter

Message	Cause	Remedy
ENG. OIL FILTER 	Engine oil dirty	Replace engine oil, oil filter
	Defective sensor	Replace ⁽¹⁾

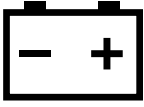
Table 27. Electrical fault

Message	Cause	Remedy
ELEC. FAULT	Short circuit, etc abnormalities	Inspect, repair ⁽¹⁾

(1) Indicates jobs which should be done by a specialist. Refer to Service Manual.

Operations

Table 28. Operating controls hard to operate

Cause	Remedy
Foreign matter caught on control valve spool	Wash the control valve ⁽¹⁾
Valve sticking	Repair or replace valve assembly ⁽¹⁾
Improper lubrication of lever link	Grease
Lever link seizure	Grease

(1) Indicates jobs which should be done by a specialist. Refer to Service Manual.

Attachments

Location

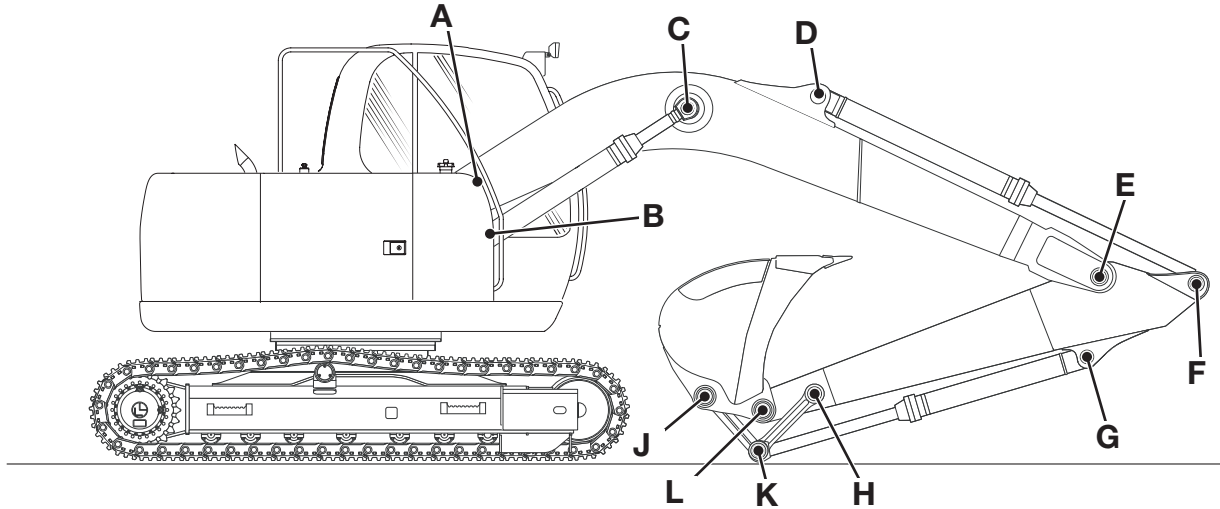

Fig 1.

Item	Equipment Name	Refer to link below:
A	Boom and Slew Frame Installation	Boom and Slew Frame Installation (🔗 B-6)
B	Boom Ram and Slew Frame Installation	Boom Ram and Slew Frame Installation (🔗 B-7)
C	Boom Ram Installation	Boom Ram Installation (🔗 B-8)
D	Dipper Ram Installation	Dipper Ram Installation (🔗 B-9)
E	Dipper Pivot Installation	Dipper Pivot Installation (🔗 B-10)
F	Dipper and Dipper Ram Installation	Dipper and Dipper Ram Installation (🔗 B-11)
G	Bucket Ram Installations	Bucket Ram Installation (🔗 B-12)
H	Dipper and Dipper Link Installation	Dipper and Dipper Link Installation (🔗 B-13)
J	Bucket and Bucket Link Installation	Bucket and Bucket Link Installation (🔗 B-14)
K	Bucket Link and Bucket Ram Installation	Bucket Link and Bucket Ram Installation (🔗 B-15)
L	Bucket and Dipper Installation	Bucket and Dipper Installation (🔗 B-16)

Bucket Link and Bucket Ram Installation

Equipment Name: For Location See, Location (B-5) .	Part Name	Code	Standard Value (mm)	Service limit (mm)
K. Bucket link and Bucket ram installation	Dipper Link	a	37	34
	Bucket Link	b	254	252
	Clearance	c	1.0-1.5	Shim for Adjustment
	Bucket Link	d	99	101
	Bucket Ram (eye end)	e	98	96
	Clearance	f	1.0-2.0	Shim for Adjustment
	Pin	g	ø65	ø64
	Bushing (Bucket link)	h	ø65	ø66.5
	Bushing (Bucket ram)	i	ø65	ø66.5

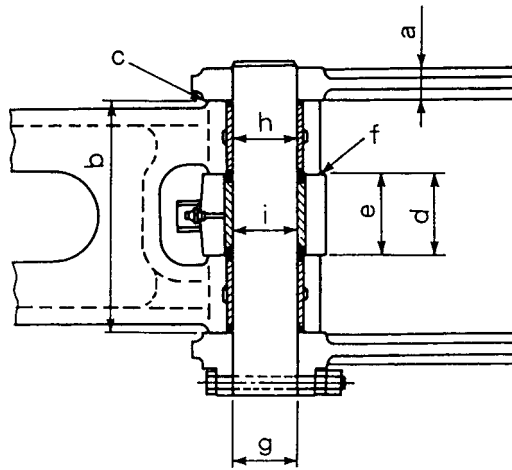

Fig 11.



PWM Controller (C)

Pin	Wire Colour	Function	Notes
1	Blue/Green	Switched +24V power from the unit	
2		Not Used	
3	White	Protected Power	Output from battery relay
4	Brown	Power to Battery Relay	
5	Blue/Orange	+12V output	Supply for control actuators
6	Green/White	Fan Control signal	Input from control panel used to adjust blower speed
7	Yellow	Fan drive low	Output to negative side of motor. Used to control fan speed
8		Not Used	
9		Not Used	
10		Not Used	
11		Not Used	
12	Black	Earth	

Recirculation Valve Actuator (D)

Pin	Wire Colour	Function	Notes
1	Blue/Orange	+12V Supply	
2		Not Used	
3	Black	Earth	
4	Blue/White	Signal	
5		Not Used	
6		Not Used	

Water Valve Actuator (E)

Pin	Wire Colour	Function	Notes
1	Blue/Orange	+12V Supply	
2		Not Used	
3	Black/Blue	Earth	
4	Blue	Signal	
5		Not Used	
6		Not Used	

Note: Do not touch the glass after cleaning with the 'Active Wipe 205'.

- b If the glass does not have a black ceramic ink band, paint a band on the glass using 'Black Primer 206J'. The band should be approximately 25mm (1in) wide, and the edge should be a neat straight line, see [Fig 13.](#) ([↗ B-35](#)).

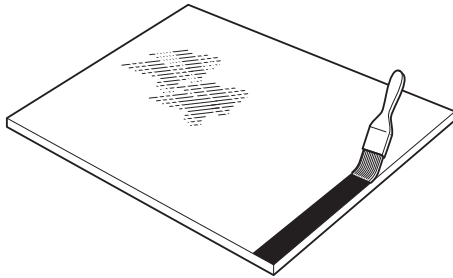

Fig 13.

- 5 Install the Ultra Fast Adhesive cartridge (see **Sealing and Retaining Compounds**, Section 1 and **Note**) into a suitable applicator gun:

- a Remove the aluminium disc cover from the base of the cartridge and discard the 'desiccant capsule'.
- b Make sure that the rolled edge of the cartridge is not damaged - if necessary, the edges should be pressed flat, otherwise it will be difficult to remove the cartridge from the applicator gun.
- c Pierce the front 'nozzle' end of the cartridge to its maximum diameter.
- d Fit the pre-cut nozzle, see [Fig 14.](#) ([↗ B-35](#)).
- e Install the cartridge in the applicator gun.

Note: Cold material will be very difficult to extrude. The cartridges must be pre-heated in a special oven for 1 hour to a temperature of 80°C (176°F). Pre-heating the cartridges makes the adhesive more workable and also brings the 'curing' time down to 30 minutes.

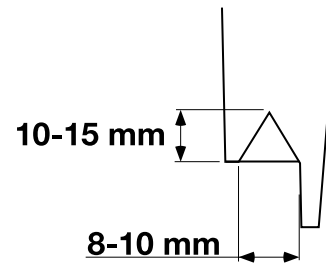

Fig 14.

- 6 Apply the pre-heated adhesive to the glass (do not start in a corner). Keep the nozzle guide **15-A** against the edge of the glass and make sure that the adhesive forms a continuous 'pyramid' shape, see [Fig 15.](#) ([↗ B-35](#))

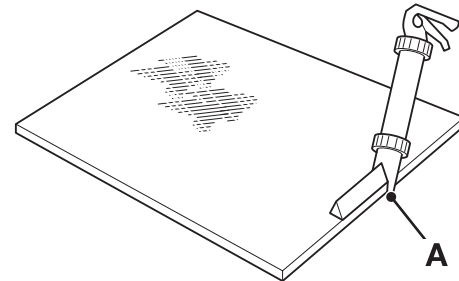

Fig 15.

Note: Once the pre-heated adhesive has been applied to the glass, install the glass in the aperture as soon as possible. After approximately 10 minutes the sealant will form a 'skin', this will prevent the glass from bonding.

- 7 After applying the adhesive, leave a small amount of sealant protruding from the nozzle. This will prevent any adhesive left in the cartridge from 'curing'.

Installing the New Glass

- 1 If the internal trim strip is damaged, renew it (cut to length as required) before fitting the new glass. Make sure the two spacer blocks are in position, see [Preparing the New Glass](#) ([↗ B-33](#)) - step 1.
- 2 Install the glass in the frame aperture:
 - a Always use the special lifting tools when moving the glass. Use a lifting strap to hold large panes of glass in position, see [Fig 16.](#) ([↗ B-36](#))

Driver Controls and Switches

Right Console

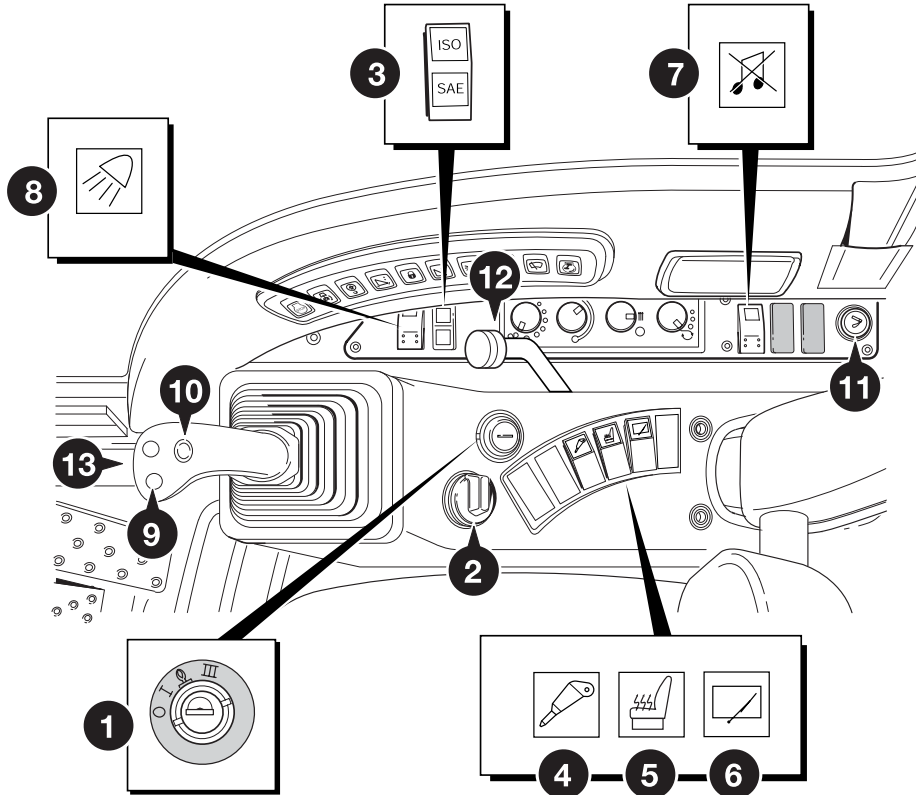

Fig 3.

1 Starter Switch.

This is operated by the starter key. It has four positions. The key can only be removed when in the 'O' position.

'O' Off/Stop Engine. Turn the key to this position to stop the engine. Make sure the controls are in neutral and the excavator and dozer are lowered before stopping the engine.

I - On. Turning the key in this position connects the battery to the electrical circuits. The key will spring back to this position when released from II.

II - Heat Position. Holding the key in this position switches on the glow plugs. The glow plugs warm the

engine combustion chambers for cold weather starting. Do not hold in this position for more than 60 seconds. The key will spring back to I when released.

III - Start. Operates the starter motor to turn the engine. The starter switch has an inhibitor to stop the switch being turned ON when the engine is running.

Note: Do not operate the starter for more than 20 seconds at one time.

Heater/Air Conditioning Controls

Located on the right console, the heater/air conditioning controls are used in conjunction with the heater fan controls.

Heater Controls

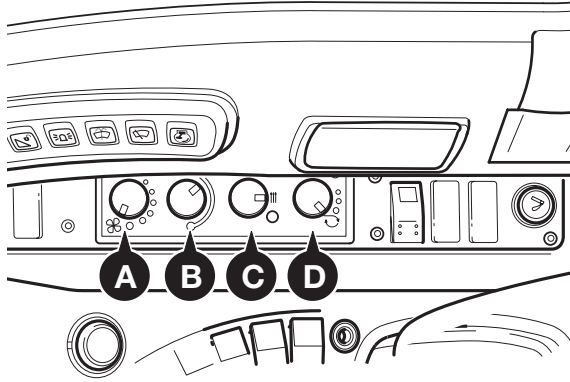

Fig 10.

Heater Fan.

Turn rotary switch **A** clockwise to turn on the heater fan. The volume of air from the heater increases by rotating the switch further clockwise.

Temperature.

Turn rotary switch **B** fully anti-clockwise for minimum temperature, turn it fully clockwise for maximum temperature. (Intermediate positions give intermediate temperatures.)

Air Conditioning Controls (if fitted).

Turn rotary switch **C** clockwise to select air conditioning, turn the rotary switch **C** fully clockwise for maximum cooling. (Intermediate positions give intermediate cooling.)

Fresh Air/Recirculated Air.

Turn rotary switch **D** fully anti-clockwise for fresh air, turn it fully clockwise for recirculated air. (Intermediate positions give a mixture of fresh and recirculated air.)

Using the Air Conditioning

- 1 In hot weather to produce comfortable working conditions.
 - a Close the door and windows.
 - b Set control **D** fully anti-clockwise so as to avoid drawing hot air in from outside the cab.
 - c Set control **A** fully clockwise to direct air into the body of the cab.
 - d Set control **B** fully anti-clockwise to avoid reheating the de-humidified conditioned air. If the in-cab temperature drops too low adjust clockwise the setting of the heat control to remedy the situation.
- 2 In cold/damp weather, to minimise misting.
 - a Close the door and windows.
 - b Set control **D** fully anti-clockwise so as to avoid drawing damp air in from outside the cab.
 - c Set control **A** fully clockwise to direct air onto the windscreen.
 - d Set control **B** fully clockwise to heat the de-humidified conditioned air, de-mist the screen and generally de-humidify the cab air.

The AMS System

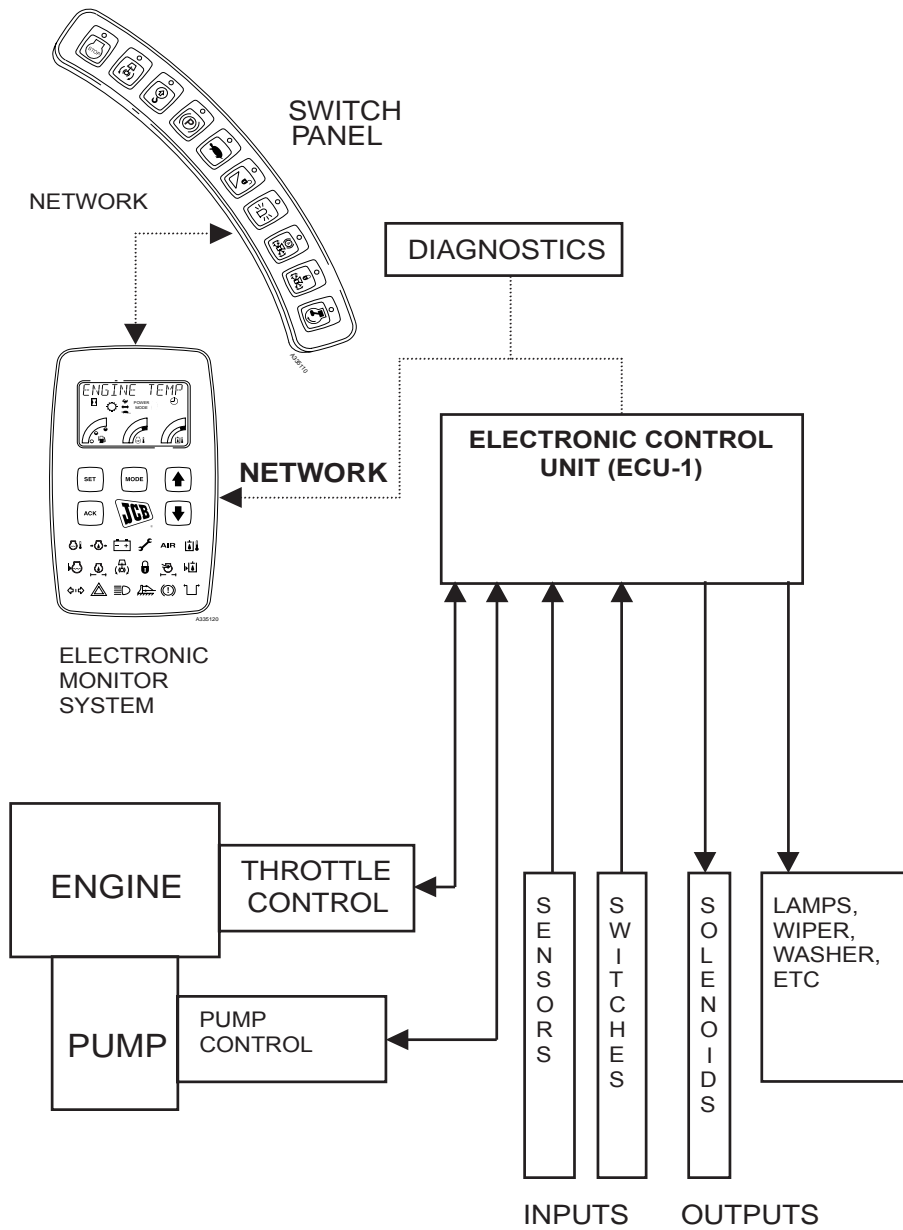

A405630-C1

Fig 24.



If the machine is switched off before completing calibration, when the machine is restarted then EMS will display the message 'Calibrate' and throttle calibration will have to be done again.

Engine Pre Heat (Glow plugs)

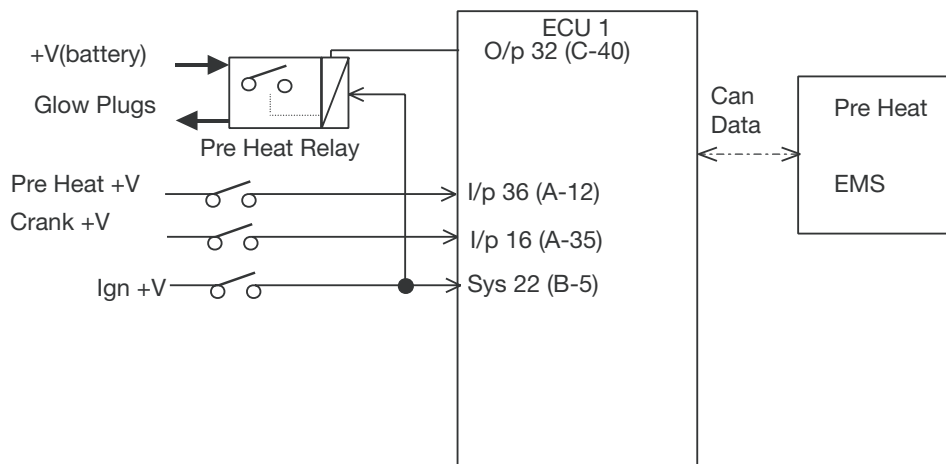

Fig 47.

Operation

This feature allows the engine cylinders to be pre heated, before engine cranking to assist cold start performance.

When the operator turns the ignition key clockwise to the 'heat' position 24v is available to the coil of heat relay from an ignition live feed. The ECU gives a ground to the heat relay coil. The relay energises which then allows battery voltage to cross the heat relay to the glow plugs, the EMS displays the message "PRE HEAT".

The pre-heat output (O/p 32 C40) can only be turned on when engine water temperature (I/p A - 18) is below 5 deg C (If pre heat selected above this temperature EMS displays pre-heat message but output is not switched on).

The pre heat output can only be switched on for a maximum of 40secs, after this time the output is switched off by the ECU. If engine is started within 5 secs of selecting pre heat the pre heat relay remains energised during cranking but no message is displayed on the monitor. If the engine is started 5 secs after selecting pre heat, the pre heat relay is switched off.

Limp Mode system

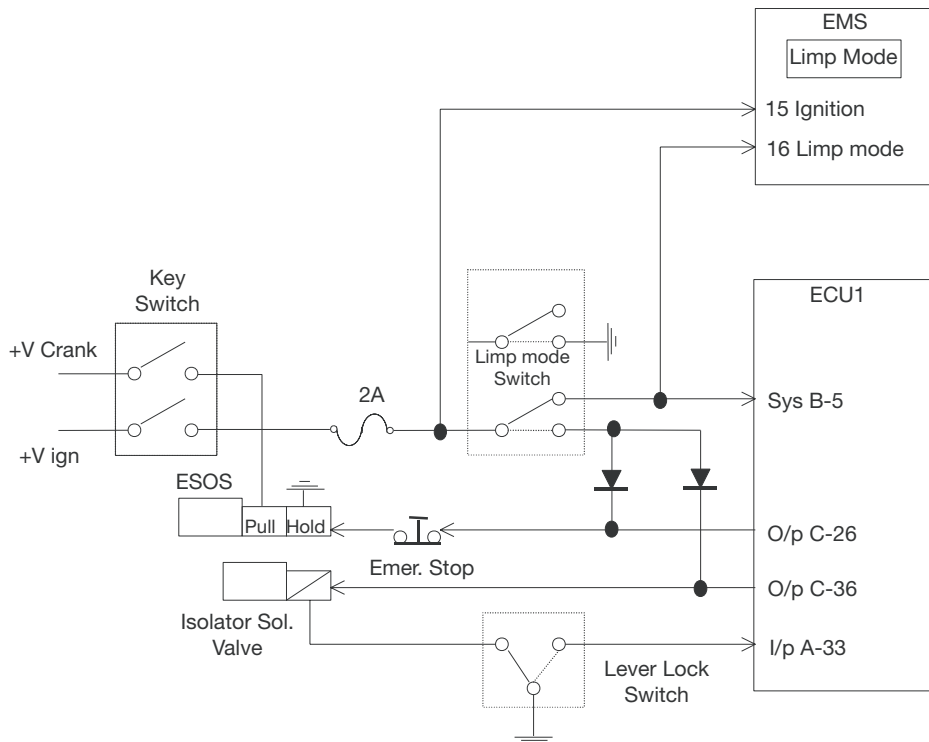

Fig 57.

Operation

In the event of a failure of the ECU1 that causes the machine to fail to start and/or fail to switch on the isolator solenoid valve, the limp mode switch can be selected which will allow these two functions to operate.

24v is available through the now closed contacts of limp mode switch via a diode to the 'hold' section of the shutdown solenoid, to hold the fuel lever in the run position.

24v is also available through the contacts of the limp mode switch and via a second diode to energise the coil of servo isolator solenoid.

At the same time the EMS will permanently display the message "LIMP MODE" and all bar graph bars will illuminate together and flash on/off at half second intervals. The internal warning buzzer will also sound, but this can be cancelled by pressing the "ACK" button.

Note: The engine will run at idle, increased engine speed can only be achieved by adjustment of the override screw which acts directly on the throttle linkage.

Wiper

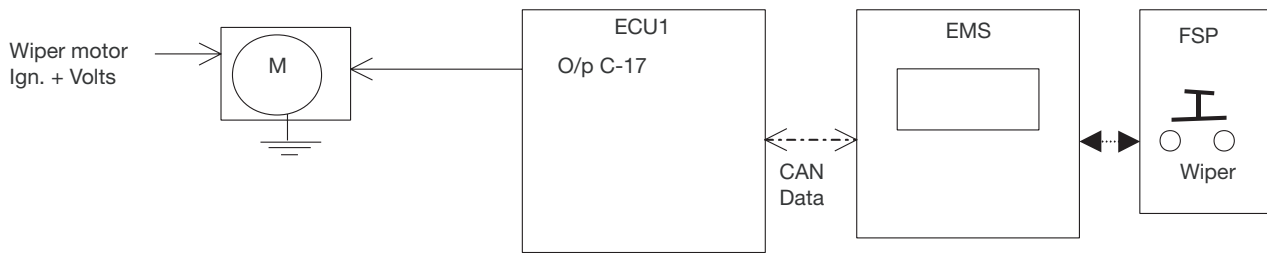

Fig 68.

Operation

The wiper has three modes of operation, intermittent, permanently on and off. Timing for the intermittent function is performed by ECU1, and can be varied via the set menu on the EMS.

When the wiper switch on the Facia Switch Panel (FSP) is pressed once O/p C 17 on ECU1 is pulsed for 0.5 seconds to start the wiper stroke. A hold on contact within the motor assembly retains power for the return stroke of the blade. A time delay of variable seconds is activated before the output is energised again, thus giving intermittent operation.

A second press of the switch enables the wiper to operate continuously and the output is permanently energised.

A third press of the switch disables wiper operation.

Soft/Hard (Cushion)

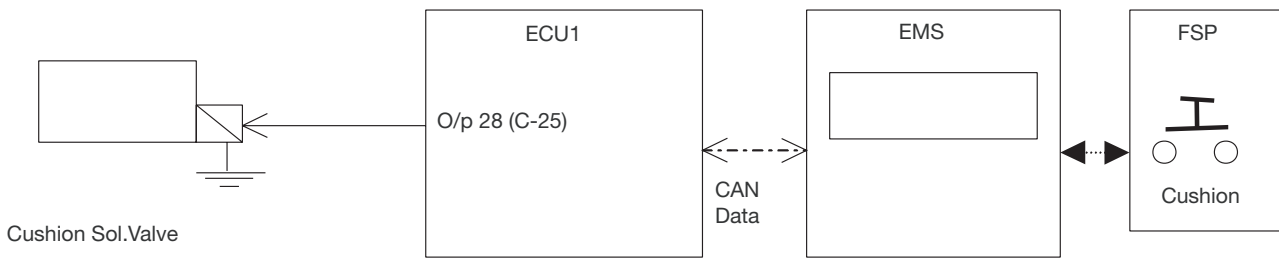

Fig 78.

Operation

The soft/hard mode allows the operator to select the response of the hydraulic circuits, soft being controlled and hard being fierce when de-selecting boom and dipper functions. Soft mode is the default setting when starting the machine.

To change to hard mode the operator must select the option by pressing cushion switch on the facia switch panel. Cushion solenoid output ECU O/pC 25 is energised.

The Hard mode is cancelled either by turning the ignition off, or by pressing the cushion switch for a second time.

Relationship between Travel Modes A / E + P, travel motor swash plate position and Pump “Q max cut output”

Travel Speed	High speed travel solenoid output ECU 1 O/p C 7	Q max cut solenoid output ECU 1 C1
Creep (Tortoise)	OFF	On (24v) only when travel pressure switch has been selected i.e. travel selected
Middle (Arrow)	OFF	OFF
High (Hare)	ON (24v)	OFF

“L” Lifting Mode

In the mid travel speed the motor swash plate is in the maximum swash position (low speed), the high speed travel solenoid (ECU1 O/p C 7) is de-energised. When only the travel pressure switch (ECU1 I/p A 16) is selected, the max flow cut solenoid (ECU1 O/p C 1) is de-energised. When the upper pressure switch (ECU1 I/p A 6) only is selected, the max flow cut solenoid valve is energised, thus setting the pump to the “Q-cut” setting. If both the travel pressure switch (ECU1 I/p A 16) and the upper pressure switch (ECU1 I/p A 6) are selected, the max flow cut solenoid (ECU1 O/p C 1) remains energised, thus leaving the pump in “Q cut” mode. The EMS displays the “Arrow” gear icon.

When the travel change switch (ECU1 I/p C 7) is pressed, the EMS displays the “Hare” gear icon. The high speed travel solenoid (ECU1 O/p C 7) is energised, moving the travel motor swash plate to minimum swash position (high speed). When only the travel pressure switch (ECU1 I/p A 16) is selected, the max flow cut solenoid (ECU1 O/p C 1) is de-energised. When the upper pressure switch (ECU1 I/p 26) is selected, the max flow cut solenoid valve is energised, thus setting the pump to the “Q-cut” setting. If both the travel pressure switch (ECU1 I/p A 16) and the upper pressure switch (ECU1 I/p A 6) are selected, the max flow cut solenoid (ECU1 O/p C 1) remains energised, thus leaving the pump in “Q cut” mode.

When the travel change switch is pressed again the EMS displays the “Tortoise” gear icon. The high speed travel solenoid (ECU1 O/p C 7) is de-energised, thus the swash plate is set to the high swash position (low speed). The Max flow cut solenoid (ECU1 O/p C 1) is energised, thus putting the pump in “Q cut” mode. The machine is now in creep travel speed mode. The operation of the travel pressure switch (ECU1 I/p A 16) and the upper pressure switch (ECU1 I/p A 6) are ignored.

The next successive press of the travel change switch (ECU1 I/p34) selects the mid travel speed and the EMS displays the “Arrow” gear icon.

L mode and travel combination

- Middle speed travel only - pump standard.
- Excavating only - Q max cut
- Travel & excavating - Q max cut

- High speed travel only - pump standard.
- Excavating only - Q max cut
- Travel & excavating - Q max cut

- Creep speed travel only - Q max cut
- Excavating only - Q max cut
- Travel & excavating - Q max cut

Coolant Level Warning

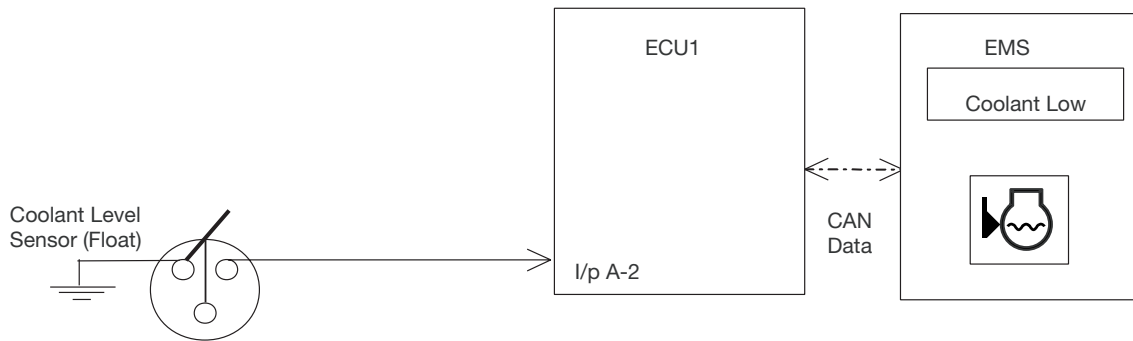

Fig 94.

Operation

A float switch is fitted to the engine coolant reservoir. When the reservoir is empty the float switch ECU1 I/p A 2 is connected to ground. This causes the EMS to illuminate the warning lamp and displays the message "COOLANT LOW" and sounds the internal buzzer.

The buzzer can be cancelled by pressing the ACK button on the EMS.

Overload Caution (option)

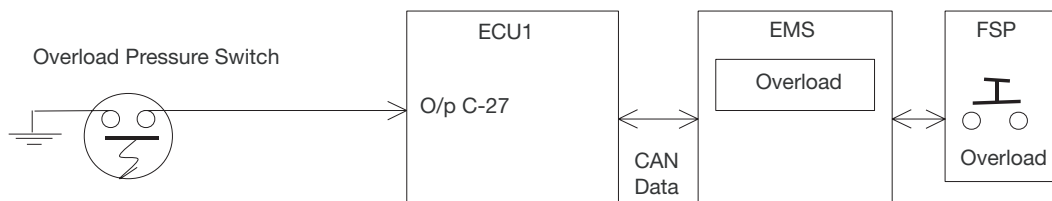

Fig 103.

Operation

The overload caution is used as a warning to the operator that the machine is lifting a mass which is exceeding the safe load capacity of the machine. An overload is indicated after the overload pressure switch (ECU1 I/p A 27) has been activated.

By default the overload override option is not enabled in A (Auto), E (Economy) & P (Precision) modes until overload switch is selected. When selecting overload switch on FSP the EMS displays the acknowledge message "overload on" A second press of the switch disables the overload override function and the status LED is extinguished.

When entering L (Lifting) Mode, the overload override warning system is automatically activated.

The status indicator for FS6 illuminates. The operation of overload switch will cancel the overload warning system.

If overload condition is reached whilst overload function is selected, EMS will display 'Overload' and buzzer will sound.

Scrap Magnet Option

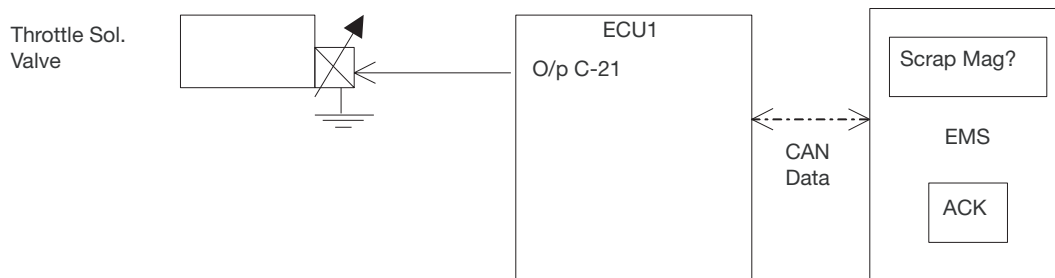

Fig 113.

Operation

When a scrap handling magnet attachment is fitted to the machine, the high voltage required for its operation is supplied by an engine driven generator. If the minimum engine rev/min. is too low, the supply voltage to the magnet may decrease to the point where any material on the magnet may drop off. To prevent this the machine has the capability to set the minimum engine speed so that it doesn't fall below a predetermined level whilst the scrap magnet is being used.

The feature can be switched on or off and the minimum rev/min. set via the SET menu of the EMS by the "SCRAP MAG" option. When this feature is enabled the throttle volume potentiometer is re-scaled so that in the minimum position the engine rev/min. is that pre-set through the following procedure.

To set the minimum engine rev/min. for scrap magnet use

Press the 'SET + MODE' button on the EMS for 5 seconds then use the scroll buttons until 'SCRAP MAG' is displayed.

Press the 'ACK' button. (This will alternate the function On/Off. Set the display to 'ON' display will change between 'MAG ON' and 'MAG OFF').

Press the 'ACK' button, display will change to 'RPM 1000'. Pressing the scroll buttons will then change the rev/min. value in 50 rev/min. increments (allowable range to be the low idle setting to S mode full engine speed setting for the particular model). The default setting for the minimum engine speed is 1000 rev/min.

The RPM setting of this feature is stored and is used each time the machine is used whilst the scrap magnet function is enabled. The scrap magnet option is switched off through the EMS SET menu.

If a target value less than the machines idle rpm is selected, then the machine will default to the original Idle setting.

Service Required Warning

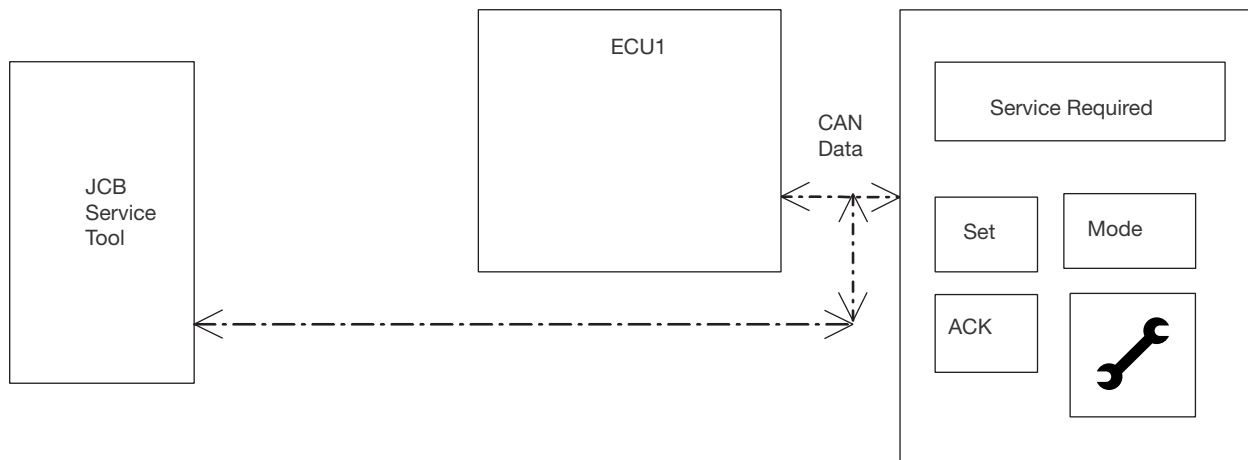

Fig 123.

Operation

The Service Required warning LED in the EMS will illuminate (no buzzer) when the next service is due, according to the service schedule. The total elapsed time will be decided by the recorded hours on the hour meter.

At the 250 hour service intervals (marked †) the LED will flash until the ACK button is pressed on the EMS and then will extinguish as a once only event. This is a reminder of a minor service only.

At the major (500 hour) service intervals, the LED will flash 20 hours before the preset 500 hour time has been reached. It will illuminate continuously 20 hours after the 500 hour pre-set time has been reached since the previous service and can only be re-set by one of the two methods as detailed below. If it reaches this point an error is written to the error log indicating that the service has been missed.

The service warning can be cancelled in one of two ways :

- 1 Through the JCB approved service tool.
- 2 Through the EMS Set + Mode (20 sec) menu -

HPSetup Overview

HPSetup is part of a suite of software modules designed for the Advanced Management System (AMS). The task of HPSetup is to ensure that the vehicle can be configured out in the field or as it leaves the production line as per customer requirements. It includes the ability to set various vehicle attachment options for differing vehicle functions/design and the programming of Alternative Languages into the EMS so the operator can view information in his/her native tongue.

Features

Vehicle Profile Read and Write functionality, offering the ability to modify the vehicles fitted options.

Data Link Adaptor (DLA) utilising the J1939 CAN Bus Standard Interface.

Application Multi Language Support, options provided to allow the PC application to operate in many different languages. Note this is not the same as Alternative Languages used in the EMS module. In this instance we refer to the PC applications switching from a standard English test to another language of choice.

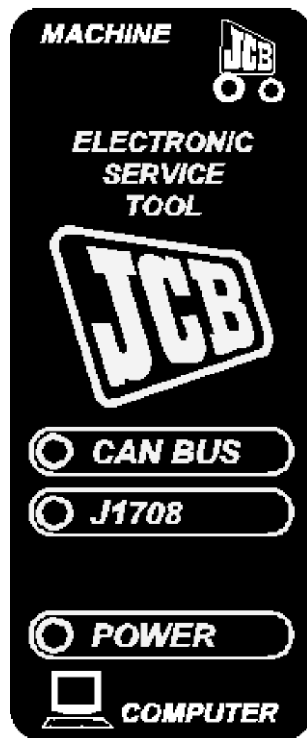

Fig 11.

Using HP Service

HP Service can be used as a standalone application or through the JCB Service Master CFE.

- 1 Connect Vehicle/DLA/PC using the supplied cables.
- 2 Power up the vehicle.
- 3 Run HPSetup.

Open Using the ServiceMaster CFE.

Open Service Master CFE.

Click on the Service History icon. See [Selecting Service Tool Applications \(C-132\)](#)

Opening Using Windows.

Click WINDOWS Start button on toolbar.

Select RUN... menu item.

Use the browse button to locate "HPService.exe".

Click OK after selecting the file.

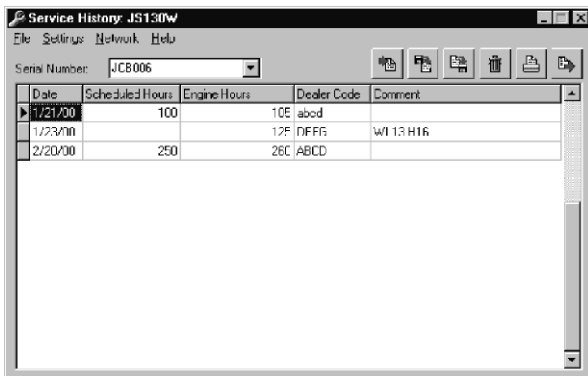
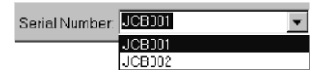

Fig 32.

The HP Service application will open and look like that shown.

Allows the User to select from the database the Service History for any vehicle that has been connected to it and downloaded.



Load Service History list from vehicle attached to PC. See [Load Service History \(C-155\)](#).



Import Service History exported from another Service History user. see [Import Service History \(C-155\)](#).



Export Service History, exports the current Service History recordset to file for another user to import. See [Export Service History \(C-155\)](#).



Delete Service History, deletes the current list of entries from the Database. See [Delete Service History \(C-156\)](#).



Print Service Record the current Service History. See [Printing Service History \(C-156\)](#).



Add Service Record, allows the User to insert a record into the current Vehicle Service History. A special option for Services which are not preplanned. See [To Add A Service History Record \(C-156\)](#).



Stopping Diagnostic Mode

To stop the diagnostic mode, press the red button or select Stop Diagnostics from the Options menu.

Stopping diagnostic mode will stop the real time monitoring of the vehicle and disengage the DLA from the CAN network. The circuit diagram windows are not refreshed with new values.

CLICK HERE TO **DOWNLOAD** THE COMPLETE MANUAL

- Thank you very much for reading the preview of the manual.
- You can download the complete manual from: www.heydownloads.com by clicking the link below



- Please note: If there is no response to CLICKING the link, please download this PDF first and then click on it.

CLICK HERE TO **DOWNLOAD** THE COMPLETE MANUAL

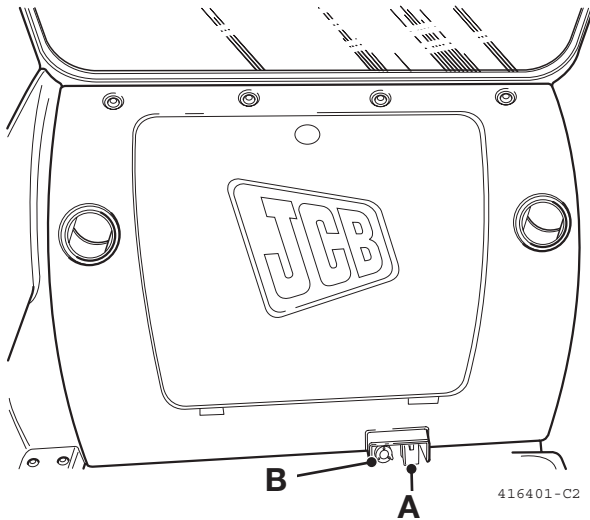

Fig 50.

Fault Diagnosis ECU-1

If the engine turns over but will not start, change to "Limp Mode" and if the machine starts the ECU-1 may have failed. This check assumes all other "Engine Failure To Start" checks have been completed.

If there is a failure of the ECU-1 unit, the machine can be moved by using the "LIMP MODE" Switch A located behind the seat.

Note: The machine will only run at engine idle r.p.m. and should only be operated in this mode to allow the machine to be moved to a safe position for repairs. The machine does not function in the same manner as earlier models fitted with a Redundancy Switch.

To test the ECU-1, several individual circuits can be used to identify ECU-1 failure. These are basic circuits which do not require the use of solenoids but are actuated by the use of a single switch.

- Horn circuit
- Wiper circuit
- Washer circuit
- Travel alarm circuit (American Machines Only)
- Work lights circuit The individual circuit can then be checked by testing the ECU-1 input and output voltages. The method of testing the input and output voltages is shown in, Section C Service Procedures.

Fault Finding Without using the JCB Service Master

ECU-1. stores the following Data Log Information:

- Hydraulic Overheating.
- Engine Overheating.
- No Throttle.
- Throttle Recalibration.
- Air Filter Blocked.
- Low Air Pressure.
- Low Engine Oil Pressure.

If the ECU-1 is changed the Data Log Information stored in it will not be transferred to the new unit, therefore if possible the Data Log Information must be downloaded before the changes take place.

EMS Failure.

When the machine is started all 18 warning indicator lamps should "flash" for approximately 1 second and the elements within the monitors Liquid Crystal Display (LCD) should come on for the same time period.

If there is a failure of the EMS unit, the machine can be moved by using the "LIMP MODE" Switch A located behind the seat.

Note: The machine will only run at engine idle r.p.m. and should only be operated in this mode to allow the machine to be moved to a safe position for repairs. The machine does not function in the same manner as earlier models fitted with a Redundancy Switch.

The EMS stores the following Data Log Information:

- Limp Mode Use.
- Alternator Low Charge Warning.
- Circuit Driver Errors (Open Circuits, Short Circuits, No Voltage.)

If the EMS is changed the Data Log Information stored in it will not be transferred to the new unit, therefore if possible the Data Log Information must be downloaded before the changes take place.

Harness Data

Main Harness Connector Location

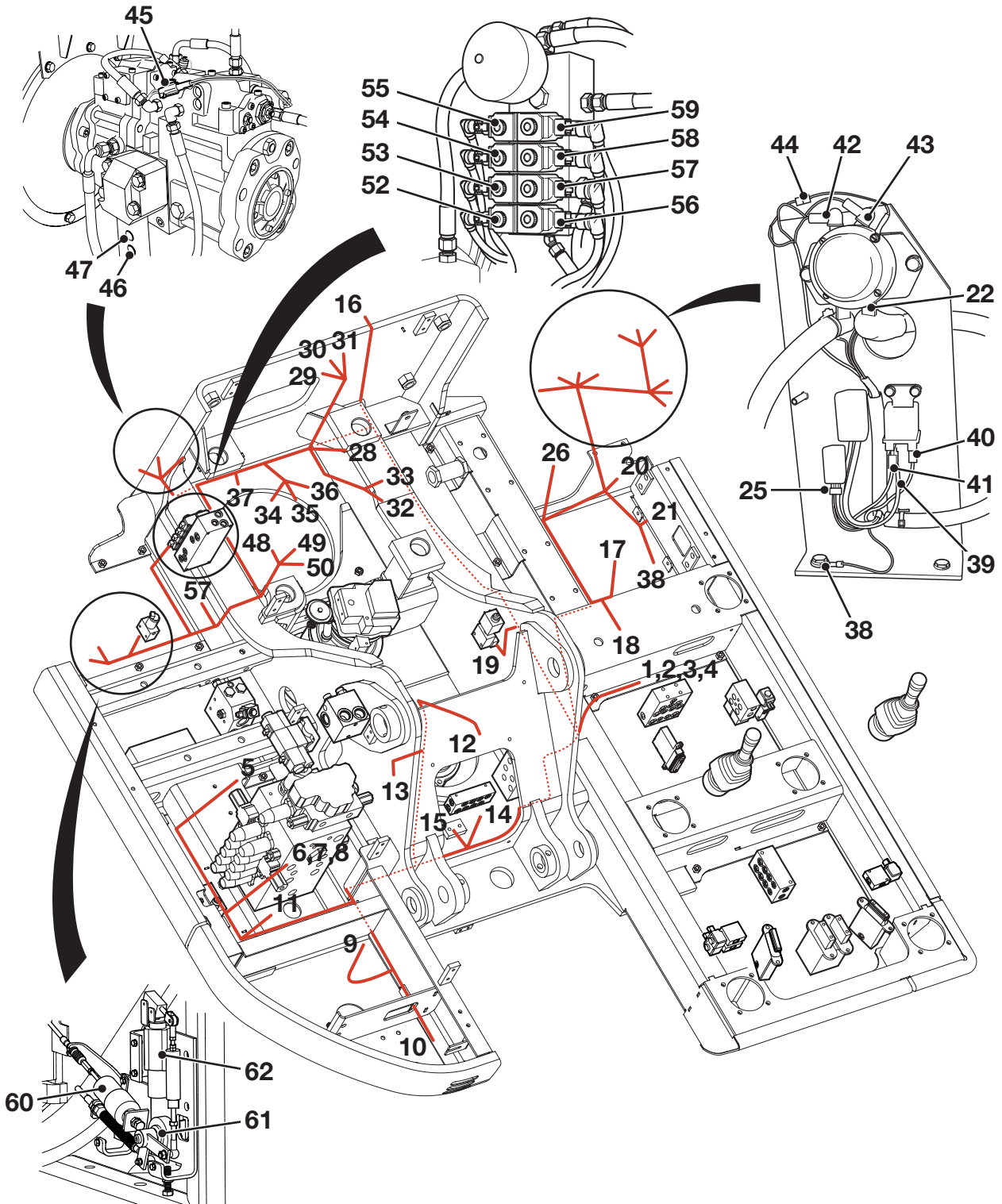

Fig 1.

Facia Link Harness A

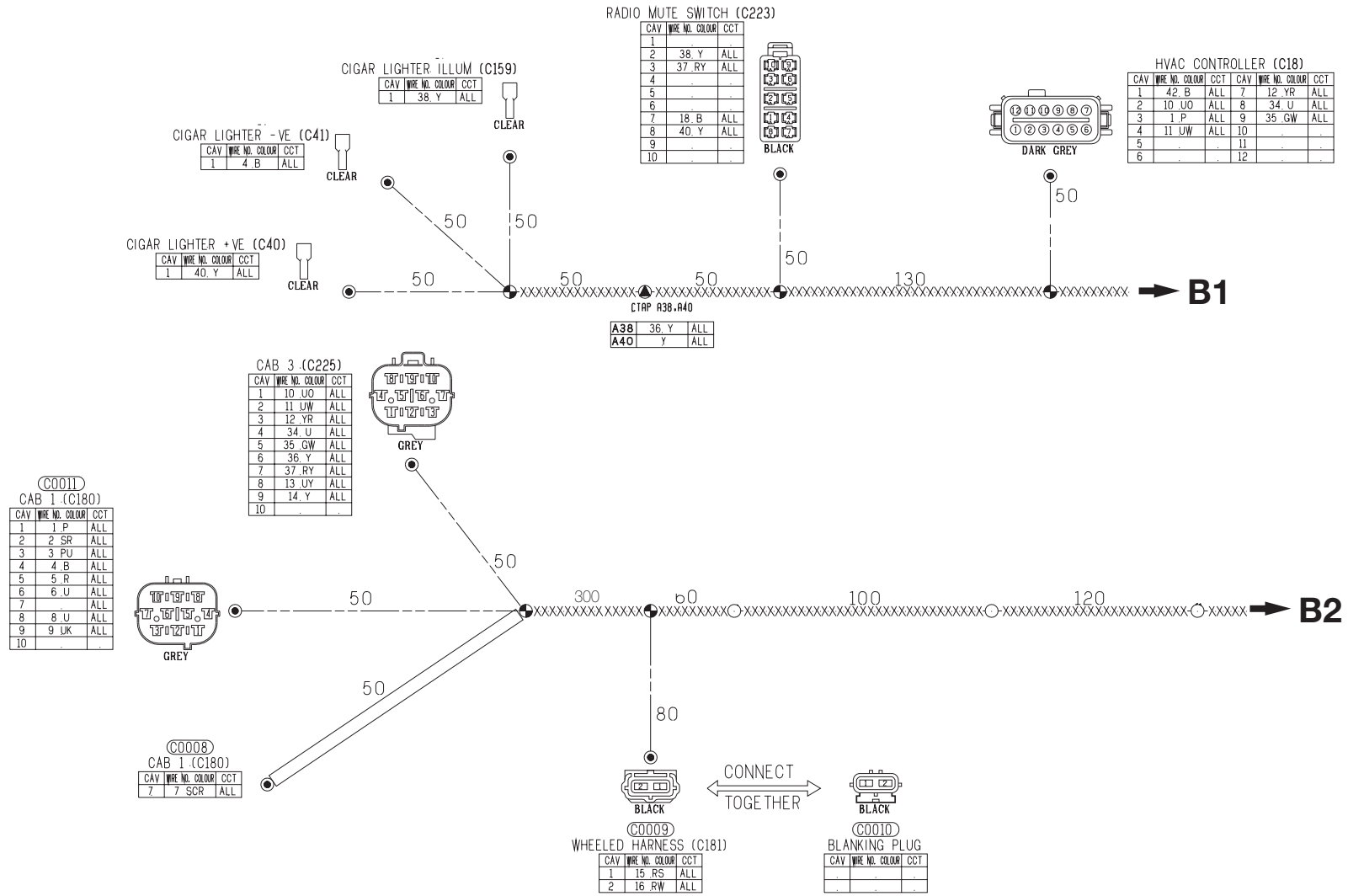

Fig 8.



Cab Harness F

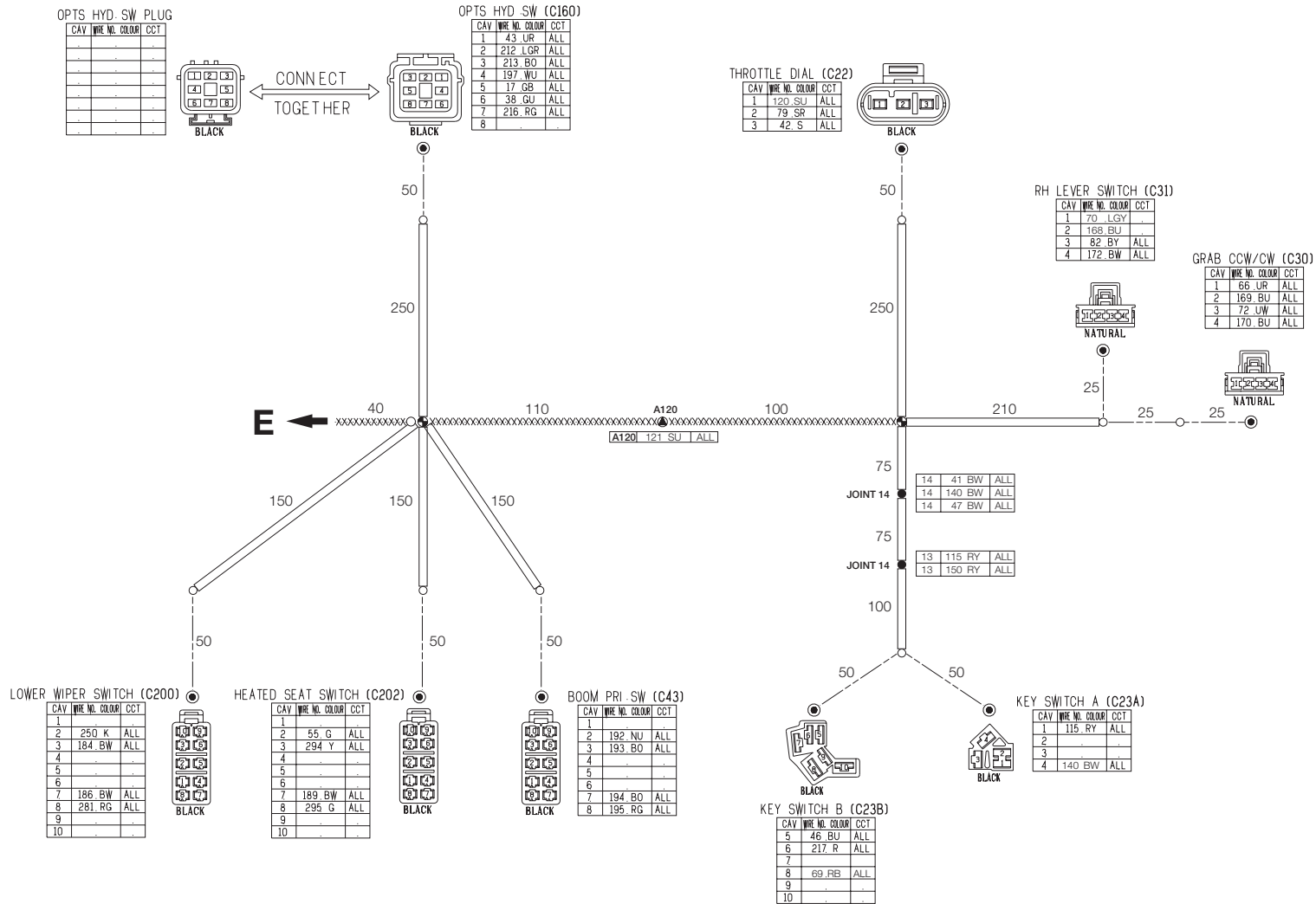

Fig 16.

Table 5. Energy Transmissions and Conditioning

	Working line, return or feed
	Pilot control
	Drain lines
	Flexible pipe
	Line junction
	Crossing lines
	Air bleed
	Line plugged, also pressure test point
	Line plugged with take off line
	Quick release couplings - connected
	Quick release couplings - disconnected
	Reservoir - return line above fluid level

	Reservoir - return line below fluid level
	Header tank
	Pressure sealed tank
	Accumulator
	Filter or strainer
	Water trap
	Cooler - with no indication of coolant flow
	Cooler - indicating direction of coolant flow
	Heater

Table 4. Port Identification

Item	Port	Function
80	A6	Travel
81	A7	Bucket
82	A8	Boom 1
83	pc2	Boom Load Holding Valve
84		Blank
85		Blank
86	ps1	P2 Negative Control Signal
87	pcc	Merge Signal
88	AR1	Option Feed from additional Pump
89		Option Load Hold Check Valve
90	Tr6	Option Pump Drain
91	AR2	Option Pump Feed
92	BR2	Option Feed
93		Option Load Hold Check Valve
94	Pr	Feed for Additional Option Pump
95	BR1	Option Feed
96	pbu	Drain for Slew Over Dipper Priority
97	T2	Tank Line
98		Load hold check Valve
99	B8	Boom down
100		Dipper Load Hold Check Valve
101	B7	Bucket
102		Boom Load Hold Check Valve
103	B6	Travel
104		Blank
105	P3	Merge Out
106	P2	Pump Feed
107		Bucket Load Hold Check Valve

For port location, See [Fig 8. \(E-28\)](#) .

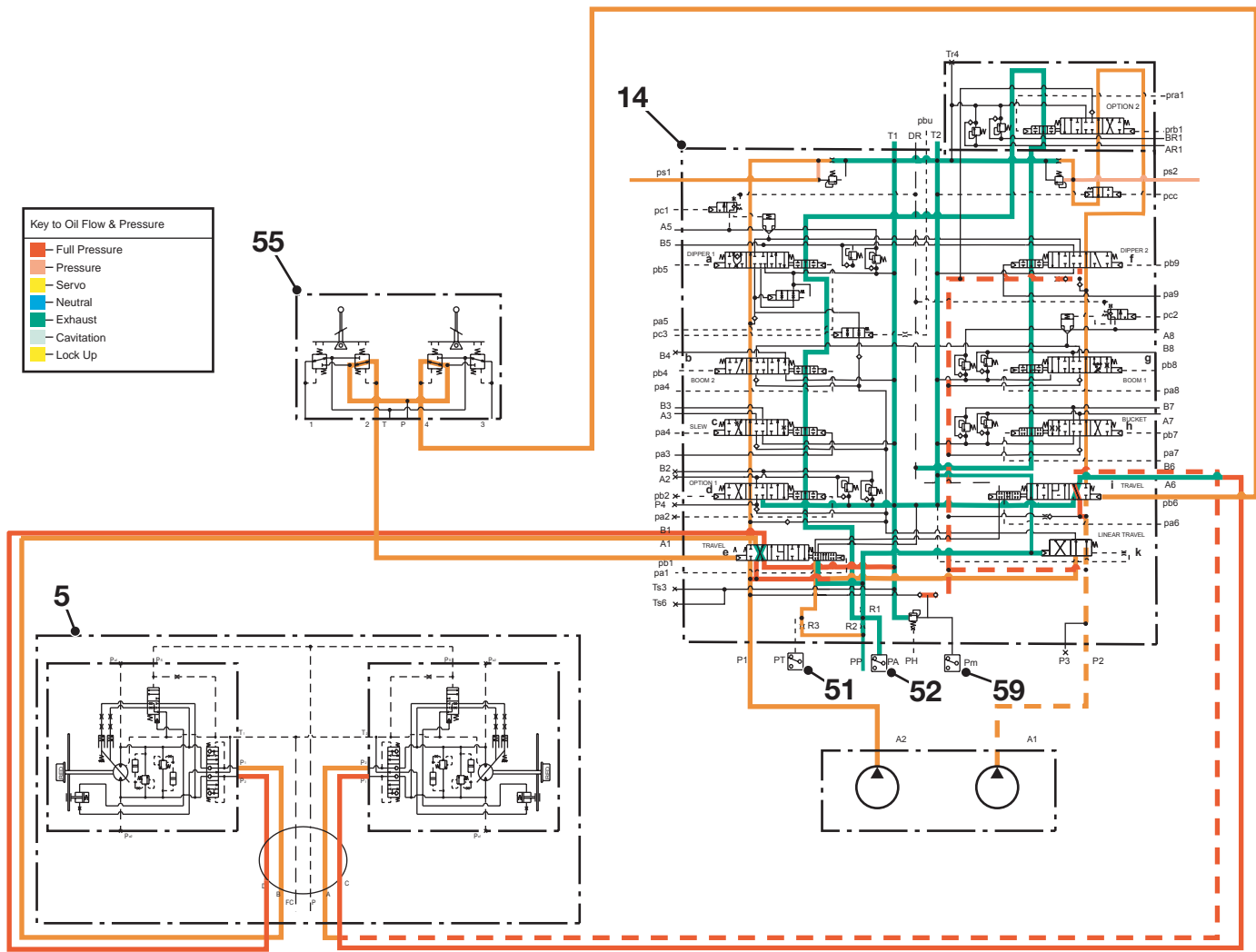

715720-C1

Fig 14. Travel Middle Speed Schematic

For description, See [Travel - Middle Speed \(E-38\)](#).

Dipper Out

For schematic, See [Fig 19. \(E-50\)](#)

Servo pressure from the Handcontroller **48** is sent to port **A5** of the shuttle valve **46** and is distributed to:

- 1** Port S4 to activate the Auto mode pressure switch **43**.
- 2** Port C3 to port Pa9 of the Main control valve **14** to activate the Dipper (2) spool.
- 3** Port B5 to port B of the Cushion valve **49**, through the valve leaving at port D. The signal is sent to port Pa5 on the Main control valve **14** activating the Dipper.(1) spool.

Flow from pump **A2** is available at the Dipper (1) spool via the left hand neutral passage and the Linear travel spool via the parallel working passage. Flow from pump **A1** is blocked at the Dipper (2) spool and joins the flow from pump **A2** just after the Dipper (1) spool.

Exhaust oil from the ram enters the Main control valve **14** at port B5 and has a path to tank via the Dipper (1) and Dipper (2) spools.

Servo pressure entering the main control valve **14** at port PP is blocked at the Dipper (1) spool, creating back pressure that causes the excavator pressure switch **52** to close.

- | | |
|----------|----------------------|
| a | Dipper (1) spool |
| b | Boom (2) spool |
| c | Slew spool |
| d | Option spool |
| e | Travel (left) spool |
| f | Dipper (2) spool |
| g | Boom (1) spool |
| h | Bucket spool |
| i | Travel (right) spool |
| k | Linear Travel spool |

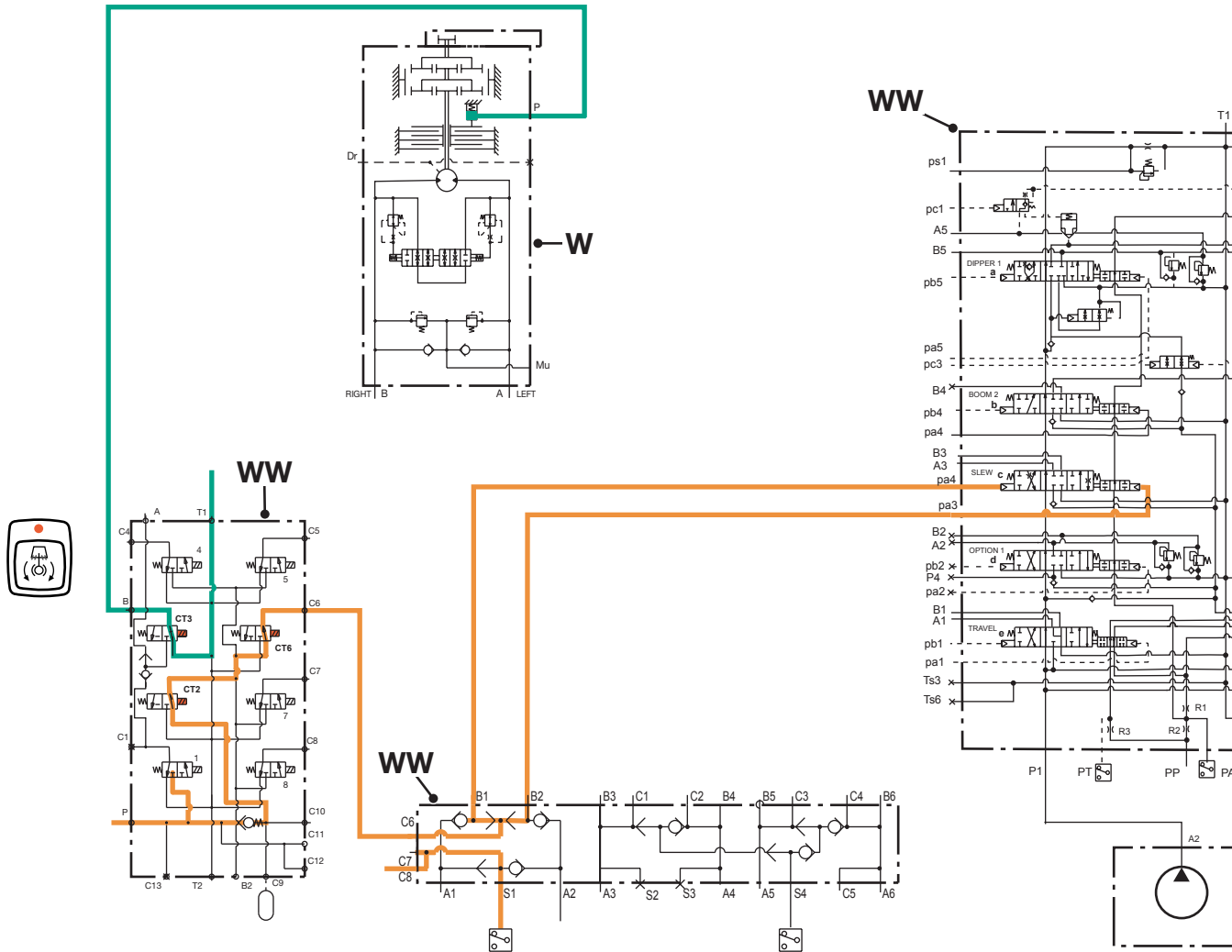

Key to Oil Flow & Pressure	
—	Full Pressure
—	Pressure
—	Servo
—	Neutral
—	Exhaust
—	Cavitation
—	Lock Up

Fig 23. 100% Slew Lock Schematic

71820-C1

For description, See [100% Slew Lock \(E-58\)](#) .



Main Relief Valve (MRV) Pressure

1 Prepare the Machine

- a Put the operator levers into neutral and lower the gate lock lever. Start the engine and park the machine on level ground. Operate the dipper out and lower the boom to set the bucket on the ground. Stop the engine. Release the hydraulic oil tank pressure. (See **Releasing Tank Pressure**).

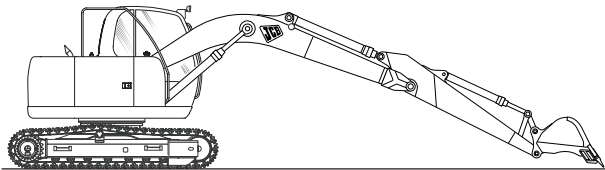
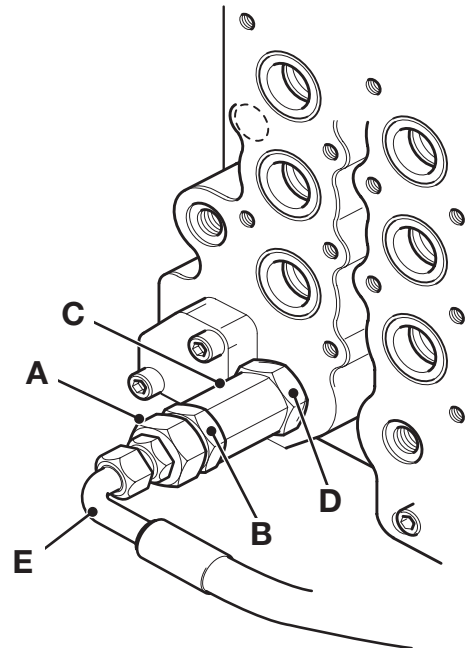

Fig 3.

- b Install a 0 - 400 bar (0 - 6000 lb/in²) pressure gauges in TP1 and TP2.
- c Start the engine, and confirm that the engine is at its 2000 rpm no-load speed and it is in the **E** mode to test standard pressure and **L** mode to test Power Boost Pressure.
- d Raise the boom and then operate the dipper out control. Read the pressure gauges with the dipper ram stalled at the end of its stroke.
- e If it is outside the limits, stop engine and adjust the MRV **1** as below.

Note: For accurate setting, the pressure should be adjusted up to the required level.

2 High Pressure Setting (Power Boost)



A406580-C1

Fig 4.

- a Remove servo hose **E** and plug hose.
- b Hold nut **C** and release lock nut **B** and screw the high pressure setting nut **A** clockwise all the way in.
- c Hold nut **C** and slacken nut **D**. Screw nut **C** in, to increase pressure or out to decrease pressure.
- d Once required pressure is achieved, hold nut **C** and lock nut **D** back up.

3 Low pressure setting (Standard)

- a Hold nut **C** and slacken locknut **B**. Screw nut **A** out to reduce pressure or in to increase pressure.
- b The pressure gauges reading should be compared to the technical data at the start of the section.
- c Lock nut **B** against nut **C**.

- 6 Stop the engine and release the hydraulic pressure (see **Releasing Tank Pressure**). Remove the pressure gauge and adaptor.

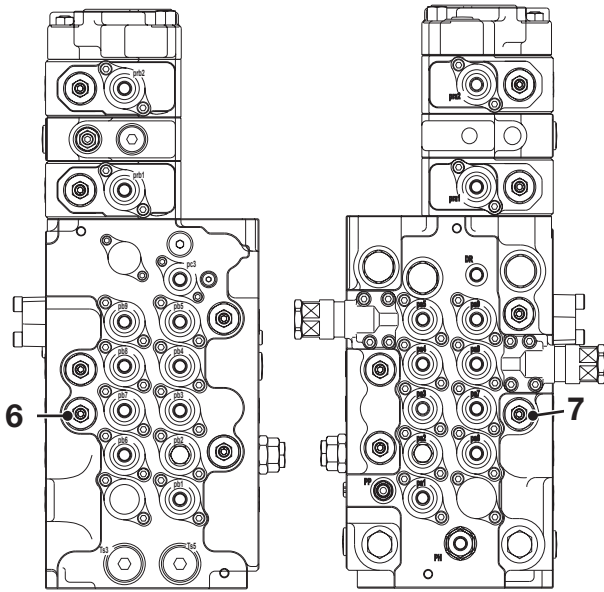

Fig 26.

- d Close the bucket fully and then continue to operate the control lever, as at **B**.
- e The pressure gauge reading (Bucket Closed) should be compared to the technical data at the start of the section. If it is outside the limits, adjust ARV 7.

Note: For accurate setting, the pressure should be adjusted up to the required level. Release lock nut **X**. Adjust setting screw **Y** to indicate a pressure below the required level and then bring the pressure back up for final setting. Tighten lock nut **X**.

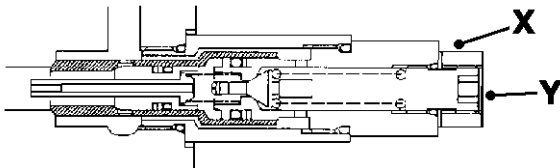

Fig 27.

- 5 If further ARV tests are necessary, carry out the relevant procedures detailed in this section. If no further ARV tests are required, restore the MRV pressure setting to its original value (see **Auxiliary Relief Valve, General**, step 3).

10 Pump 1

Remove snap ring **20** and bearing spacer **21**. Using a plastic hammer, gently tap shaft **22** out of its support bearing **32** to remove it from swash plate support **17**.

Pump 2

Gently tap shaft **22A**, at the end nearest the mating flange of valve block **8**, to separate it from swash plate support bearing **32A**.

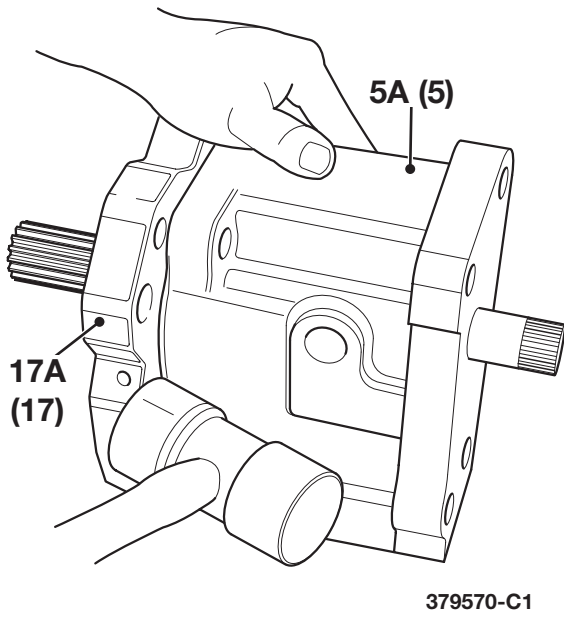

Fig 9.

- 9 Remove shoe plate **18** and swash plate **19** from pump casing **5**.

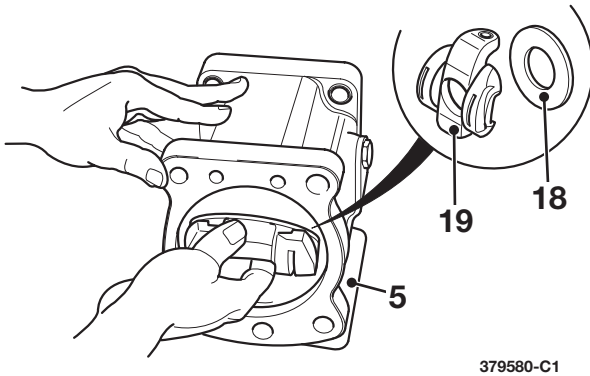

Fig 10.

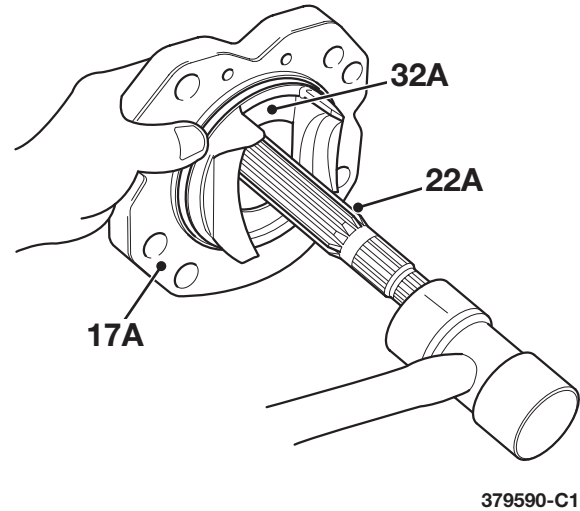

Fig 11.

- 11 Remove valve plate **23** from valve block **8**, See [Fig 12. \(E-90\)](#).

- 8** Insert adjusting plug **31**. Fit a new seal **30A** and install snap ring **30**.

Check that feedback lever **35** moves freely but does not have excessive play.

- 9** Insert return spring **25** and spring seat **24** into hole **A** of regulator body **1**. Compress the spring and secure with snap ring **23**.

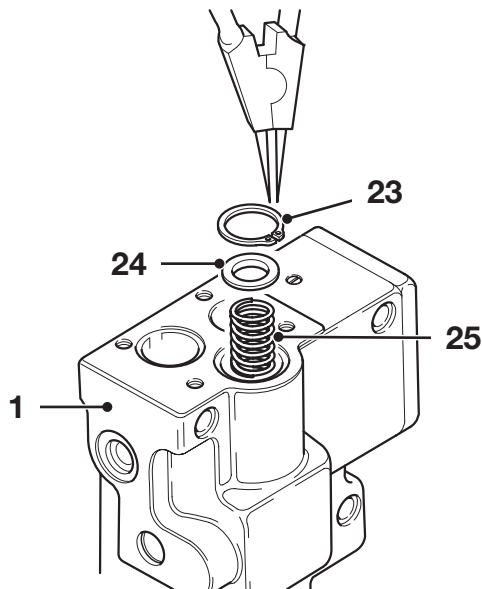

379500-C1

Fig 24.

- 10** Insert set spring **22** into hole **A** of regulator body.

Insert compensating piston **41** and piston case **40** into hole **B** of regulator body **1**.

Fit pilot cover **21** and secure with socket head screws **19** and **20** tightened to a torque of 11.8 Nm (10.3 lbf ft).

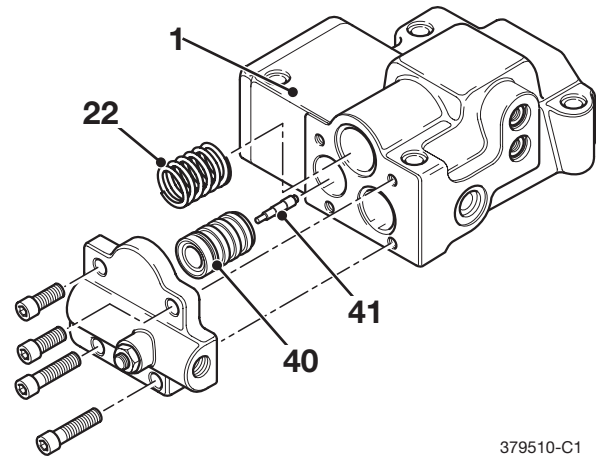

379510-C1

Fig 25.

- 11** Insert spring seat **18** (flat face first), pilot spring **17** and adjusting ring **16** into hole **E** of regulator body **1**.

Insert spring seat **15** (flat face first) inner spring **14** and outer spring **13** into hole **D** of regulator body **1**.

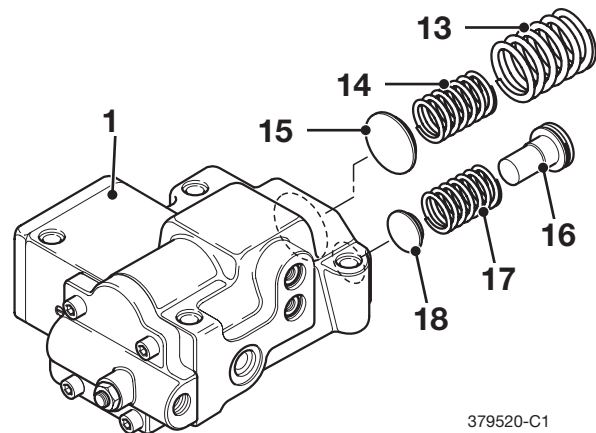

379520-C1

Fig 26.

- 12** Install the cover **6** assembly comprising adjusting screws **7/8**, adjusting ring **12**, mounting nut **11**, two locking nuts **10** and adjusting screw **9**.

Secure the cover using socket head screws **5** tightened to a torque of 11.8 Nm (10.3 lbf/ft).

Inspection

Before assembling the Remote control valve make sure that a thorough inspection of all the components is carried out. Remember that although a failed component may be easy to identify, the cause may be less easy to trace. It is also possible that a failed component may have caused damage to other areas of the valve.

- 1 Carefully clean all components using a suitable degreasing agent.
- 2 Carefully inspect all components for signs of excessive wear or damage. If wear or damage is evident, components must be renewed.

Note: *O-rings rings and other sealing materials should preferably be replaced each time the valve is disassembled but they may be re-used provided a careful check is made that they are undamaged.*

Removal and Replacement

WARNING

Hydraulic Pressure

Hydraulic fluid at system pressure can injure you. Before disconnecting or connecting hydraulic hoses, stop the engine and operate the controls to release pressure trapped in the hoses. Make sure the engine cannot be started while the hoses are open.

INT-3-1-11_1

Removal

- 1 Turn off engine. Operate the control joysticks back and forth and side to side to vent residual pressure.
- 2 Disconnect all the electrical connections to the solenoids **2A**, labeling which connector goes to which solenoid.
- 3 Disconnect all hydraulic pilot hoses from the valve block and plug all orifices to prevent ingress of dirt. The hoses should be labelled, if not label each hose before disconnecting, this will ensure correct position when refitting.
- 4 Remove the four M8 bolts from rear of valve and remove valve from machine.

Replacement

Replacement is a reversal of the removal sequence.

WARNING

Fluid Under Pressure

Fine jets of fluid at high pressure can penetrate the skin. Keep face and hands well clear of fluid under pressure and wear protective glasses. Hold a piece of cardboard close to suspected leaks and then inspect the cardboard for signs of fluid. If fluid penetrates your skin, get medical help immediately.

INT-3-1-10_2

Note: All hydraulic adapters that are installed together with a bonded sealing washer must also have JCB Threadseal applied to the threads of the adapter.

Dismantling and Assembly

Dismantling

- 1 Remove adapter **6A** and O-ring **6B** from valve.
- 2 Extract spring **6C**, spool **6D** and spring **6E**.
- 3 Remove adapter 6 from valve and repeat step 2

Inspection

Before assembling the solenoid valve make sure that a thorough inspection of all the components is carried out. Remember that although a failed component may be easy to identify, the cause may be less easy to trace. It is also possible that a failed component may have caused damage to other areas of the valve.

- 1 Carefully clean all components using a suitable degreasing agent.
- 2 Carefully inspect all components for signs of excessive wear or damage. If wear or damage is evident, components must be renewed.

Assembly

Assembly is a reversal of the dismantling sequence.

- 1 Lubricate spool **6D**, springs **6C** and **6E** with clean hydraulic oil.

Table 1. Hydraulic Connections

Port		Hose Colour
A	=	Pink
B	=	Green
C	=	Pink
D	=	Green
F	=	Blue
G	=	Red
H	=	Blue
R	=	Yellow/Green
S	=	Yellow/Yellow
T	=	White/Red

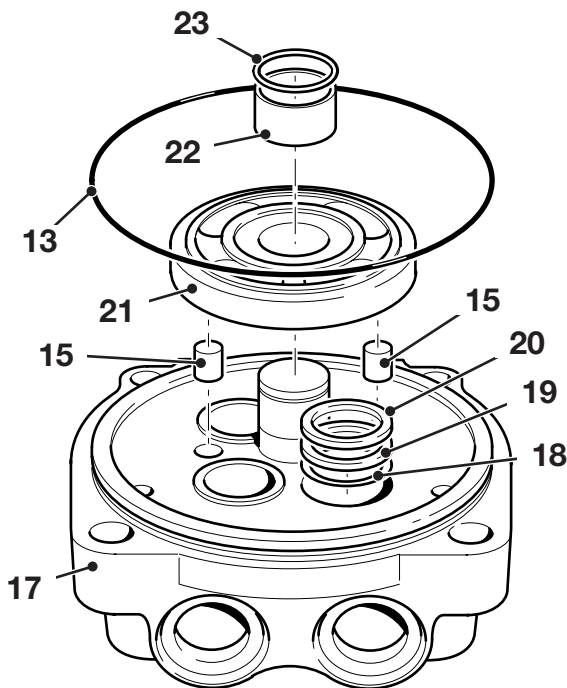

JS05680-C1

Fig 10.

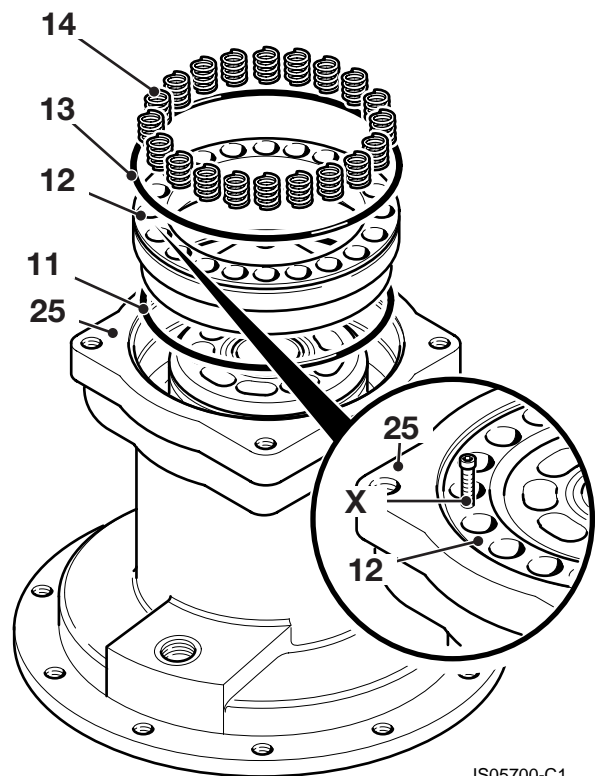

JS05700-C1

Fig 11.

- 13 Remove the springs 14 from brake piston 12.

Note: Keep the springs in the order in which they are to be reinserted.

- 14 It may be difficult to remove brake piston 12 from housing 25 due to resistance caused by 'O'-rings 11 and 13. Therefore remove brake piston 12 using the tapped M6 holes X as shown in the illustration.

- 15 Remove 'O'-ring 11 from housing 25 and 'O'-ring 13 from brake piston 12.

- 16 Remove friction plate 9 and mating plate 10.

- 17 Hold the end of cylinder 24 by hand and pull out the cylinder assembly from housing 25.

Note: The oil seal 2 and the outer ring of taper roller bearing 3 remain in the housing.

The end face of the cylinder should be protected by clean cloth to prevent it from being damaged.

Make alignment marks or write numbers on the piston bores and the piston assemblies so that the piston assemblies can be replaced in the same bores during reassembly.

- 18 Remove the outer ring of taper roller bearing 3 from the housing.

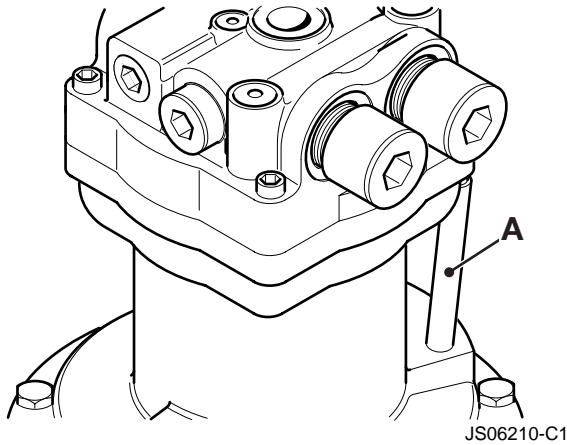

Fig 30.

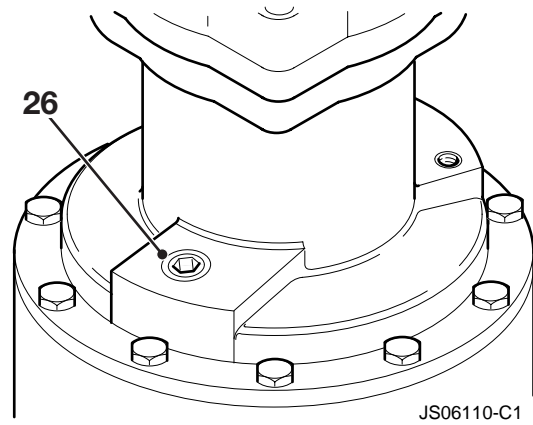

Fig 32.

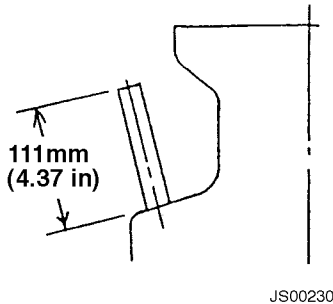

Fig 31.

- 30** Fill with gear oil through the filler port.

Insert plug **26** with an 8 mm Allen key and tighten to torque of 39.32 Nm (29 lbf ft).

Note: Fill the hydraulic motor case with hydraulic oil before connecting the piping to the drain port.

See **Fluids and Lubricants, Section 3**, for type and quantity of oil.

- 31** Apply grease (type and capacity is given in **Fluids and Lubricants**).

Note: Bleed air in the chamber from the air bleed port before filling with grease, as a build-up of internal pressure can damage the oil seal.

After the unit is filled, run it for around 10-15 minutes at zero load, and at low speed and verify that there is no abnormal noise or vibration. Gradually bring the system into high speed and loaded operation.

Item	Nm	Kgf m	lbf ft
B	103	76	16
26	39	29	4
27	157	116	16
28	78.5	58	8
30	137	101	14

Replacement

- 1 Align the coupling to the lower frame and tighten the three bolts **C**.

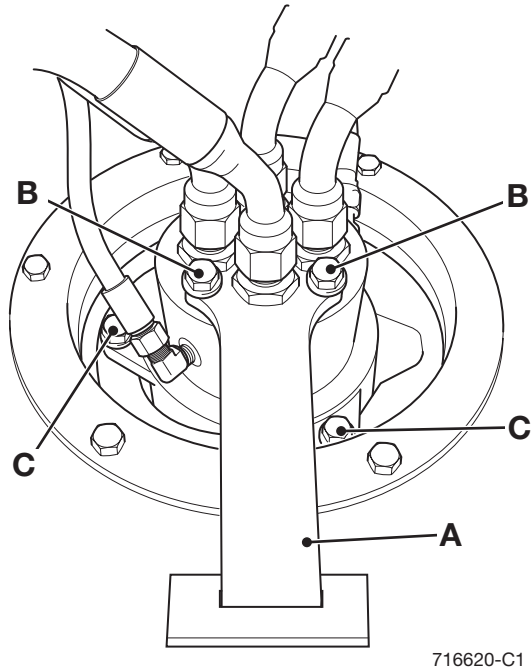

Fig 5.

Install the lock bar **A** and tighten the two bolts **B**.

- 2 Reconnect the hoses, and install the access cover. Start the machine and check for leaks.

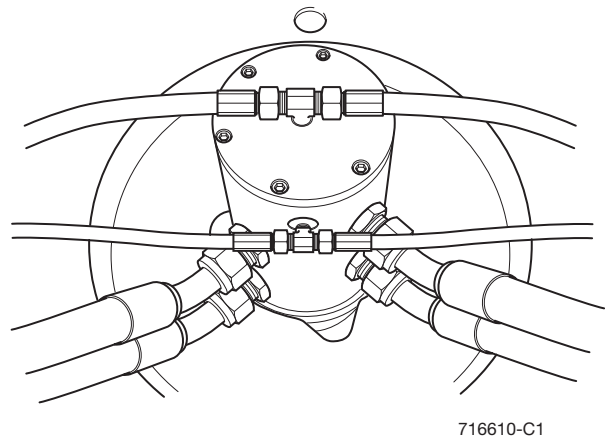

Fig 6.

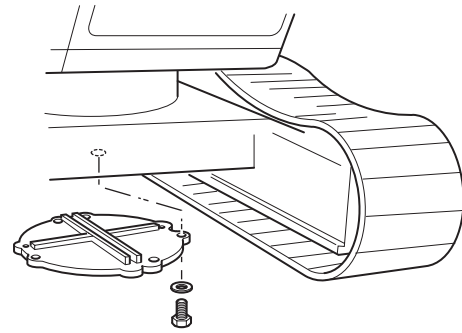

Fig 7.

WARNING

Fluid Under Pressure

Fine jets of fluid at high pressure can penetrate the skin. Keep face and hands well clear of fluid under pressure and wear protective glasses. Hold a piece of cardboard close to suspected leaks and then inspect the cardboard for signs of fluid. If fluid penetrates your skin, get medical help immediately.

INT-3-1-10_2

Replacement

- 1 Attach a sling to the ram and lift it into position on the dipper.

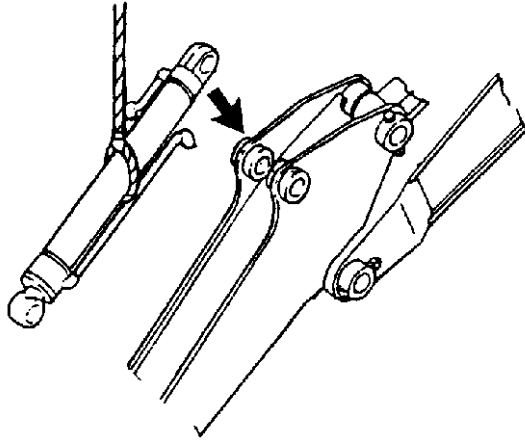

Fig 10.

- 2 Install the pin, bolt and nuts to the cylinder end of the ram.

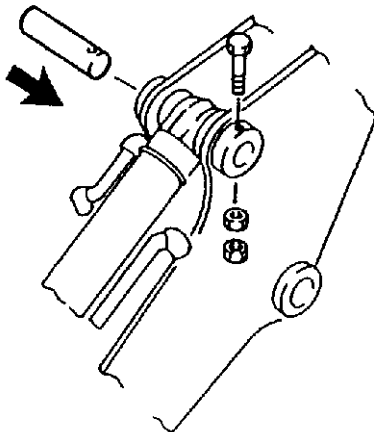

Fig 11.

Note: When checking or refitting JZ machine pivot pins, the retaining nuts and bolts should not be fastened up tight to the pivot boss but must have approximately 3mm of play so that the pin is free from tension.

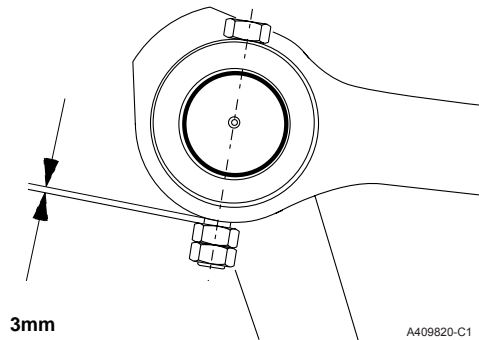

Fig 12.

A409820-C1

- 3 Connect the hoses.

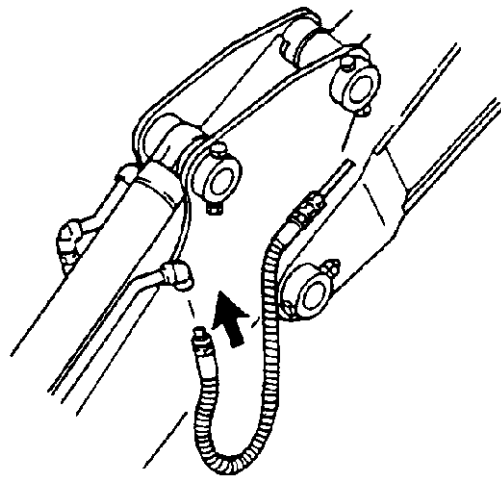

Fig 13.

- 4 Hoist the ram to align with the link.

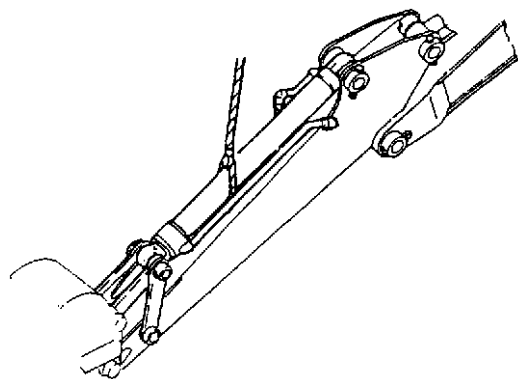

Fig 14.

Triple articulated Boom (TAB) Ram

General

WARNING

Hydraulic Pressure

Hydraulic fluid at system pressure can injure you. Before disconnecting or connecting hydraulic hoses, stop the engine and operate the controls to release pressure trapped in the hoses. Make sure the engine cannot be started while the hoses are open.

INT-3-1-11_1

WARNING

Lifting Equipment

You can be injured if you use faulty lifting equipment. Make sure that lifting equipment is in good condition. Make sure that lifting tackle complies with all local regulations and is suitable for the job. Make sure that lifting equipment is strong enough for the job.

INT-1-3-7

Removal

- 1 Park the machine on level ground and, with the bucket and dipper rams fully retracted and the TAB ram partially extended, lower the attachment to the ground.

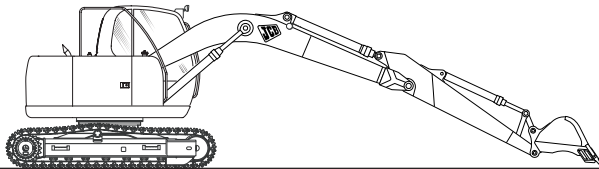

Fig 54.

Stop the engine and remove the key.

- 2 Attach suitable lifting gear to the TAB ram and just take take up the slack.

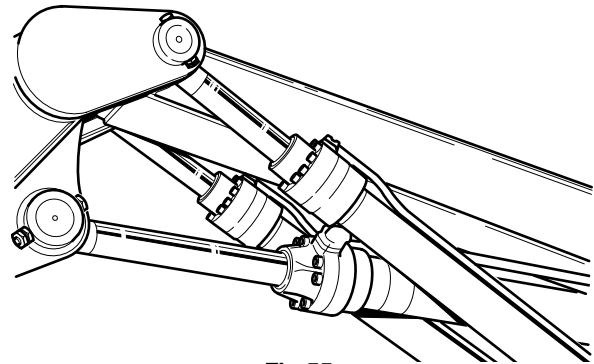

Fig 55.

- 3 Release the tank pressure (see **Releasing Tank Pressure, Section 3**)

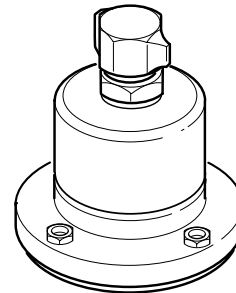
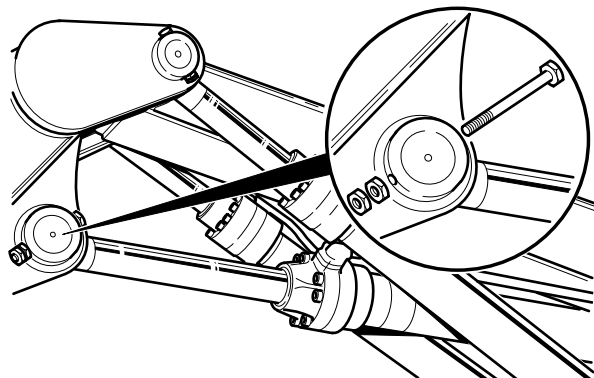

Fig 56.

- 4 Remove the pivot pin retaining nuts and bolt from the rod end of the ram.



JS07250-C1

Fig 57.

Ram Piston Head Nut

Removal and Fitting

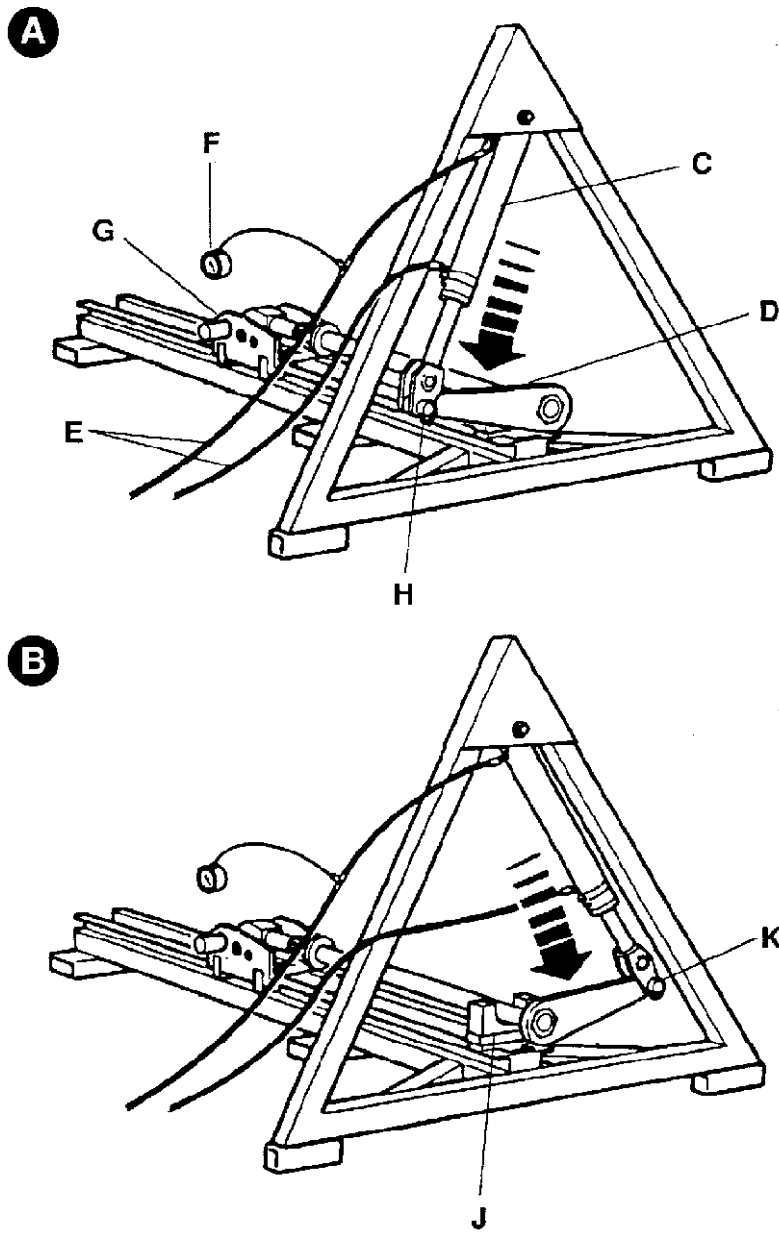

JS00960

Fig 73.

gap between the adjuster and the wedge upper surface.

Note: Do not remove the adjuster **95J** and wedge from the chuck assembly .

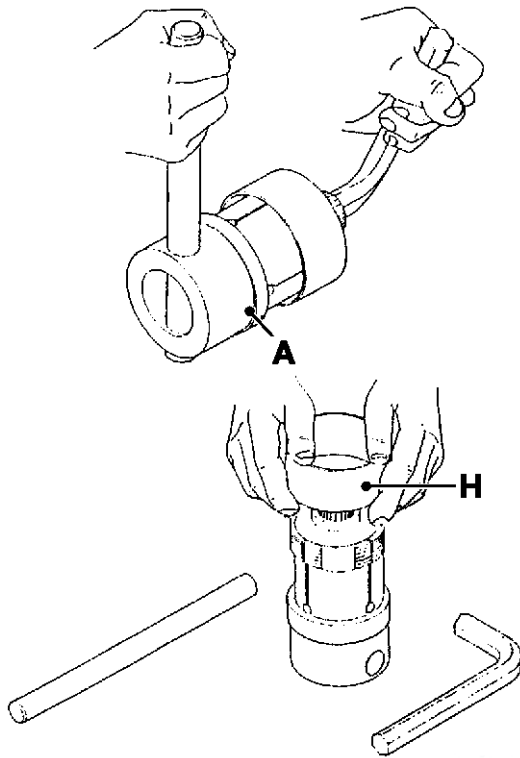

Fig 94.

11 Retightening the adjuster

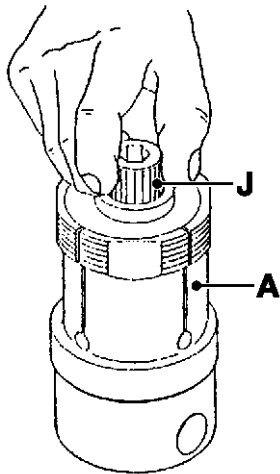

Fig 95.

With chuck assembly **95A** and the bushing removed, turn the adjuster with your fingers until there is no



Main Control Valve

Symptoms	Possible Causes	Countermeasures
Spool sticking	1. Oil temperature is abnormally high.	Remove the obstruction.
	2. Hydraulic oil is dirty	Replace the hydraulic oil and clean the circuit at the same time.
	3. Port connector is tightened too much	Check the torque.
	4. Valve housing is deformed due to Installation	Loosen the installation bolt and check.
	5. Pressure is too high	Attach pressure gauge to pump port and ram port and check the pressure.
	6. Spool is bent	Replace the valve assembly.
	7. Return spring is damaged	Replace the damaged parts.
	8. Spring or cap is not on straight	Loosen the cap and after aligning, tighten.
	9. Temperature inside valve is not even.	Warm up the circuit.
Spool does not stroke	1. Valve is clogged inside with dirt	Remove the dirt (flushing).
Load cannot be maintained	1. Oil leakage from the ram	Check the ram.
	2. Oil is by-passing from the valve spool	Replace the valve assembly.
	3. Oil leakage from the port relief valve	Remove the port relief from the housing and clean the housing seat and relief valve seat.
	4. Oil leakage from the lock valve	Disassemble the lock valve and clean the poppet seat and sleeve, plug seat. If the seat is damaged, replace the poppet, or lap the poppet and seat.
When the spool is selected from neutral to raise position, the load falls.	1. Foreign matter in load check valve	Disassemble the check valve and clean.
	2. Check valve poppet or seat damaged	Replace the poppet or lap the poppet and seat part.



Section E - Hydraulics Fault Finding

Hydraulic Rams

Item	Symptoms	Related Parts	Trouble	Treatment
4	4-2 Inner oil leakage. Piston rod extends when work stops or lowers abnormally during work. Also, specified operating speed is not achieved.	Piston seal	Scratches, wear are present	Replace with new part. Inspect the cylinder tube inner surface.
		Cylinder tube	Scratches, rust on the inside	Remove the scratches/rust by honing or with an oil stone and make the surfaces smooth. If the scratch is deep and cannot be repaired, replace the cylinder Replace piston seal.
		Piston Nut	Loose nut	Tighten to specified torque
		Valves	Leak from valve	Inspect the valve leakage amount and service.
	<p>Note: Note: Hydraulic oil expands and contracts due to changes in temperature and pressure. Accordingly, the ram also expands and this can be mistaken for internal leakage. When inspecting for internal leakage, do so at set conditions</p>			
	4-3	Air	Air remaining inside ram Operation is unsteady	Bleed the air. For rams that do not have an air bleeder, operate back and forth several times at low pressure and low speed to bleed the air. For rams with an air bleeder, remove the load to reduce the pressure then loosen the air bleeder and completely bleed the air. Note: The ram may expand if it is stopped suddenly. This is due to the compression of the hydraulic oil. This occurs especially with long stroke rams.
	4-4 Heavy shock loading when changing from extension to retraction and back	Pin bushing, Pin	Gap between installation part and pin bushing is too large	Measure the pin and pin bushing and replace parts if measurements exceed the specifications.
	4-5 Noisy operation	Oil supply	Insufficient oil	Add oil.
		Pin bushing, Pin	Scuffing at connecting part	Replace with new part and add oil.
<p>Note: If left in the state where operation is poor, the ram will no longer move and other parts will be affected adversely. Inspect early and carry out appropriate measures.</p>				

Test 005: Checking the Operation of the Main Hydraulic Spool

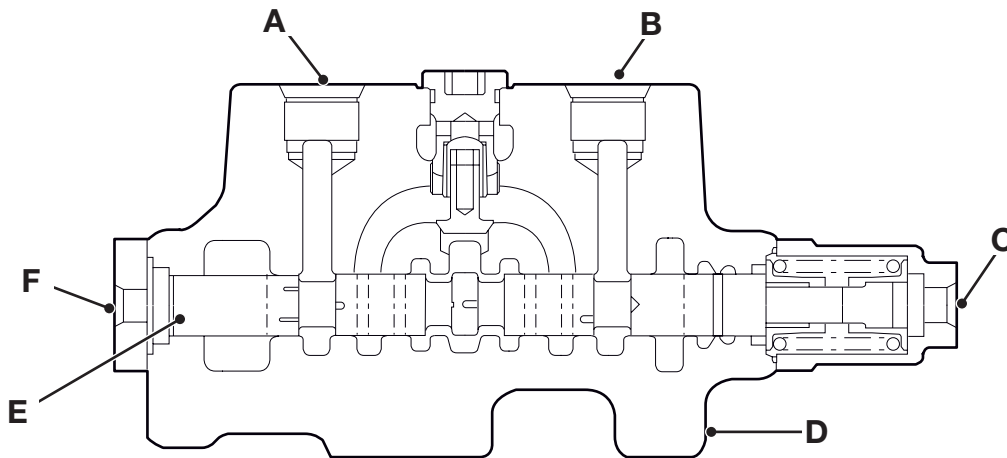

Fig 9. Sectional view of valve block showing spool and pilot ports

- A** Cylinder port B
- B** Cylinder port A
- C** Pilot port a
- D** Valve block
- E** Main spool
- F** Pilot port b

Insert a piece of stiff clean wire (Approximately 2 mm (0.08 in) diameter) through the adapter in the port not being selected until the spool end is felt.

Slowly select the spool from the selected end using the port power pack, measure the distance the spool moves and check against the graph below. (If using the accumulator pressure, turn on the machines ignition, lower the lever lock and select the service.

Identify which is main directional spool for service being tested, and which side of that spool is supplied pilot pressure when service is operated in desired direction

Fit pressure gauges 0 - 60 bar (0 - 1000lb in²) to this port and also to port on opposite end of spool

Warm up hydraulic system to 50 °C (122°F)

Remove the hose from the spool port that is not being selected and plug the hose.

Remove the hose from the spool end that is being selected and plug the hose. Couple a hand pump (see Service tools) with a pressure 60 bar (0 - 1000lb in²) gauge attached. (Instead of using a hand pump, the pressure from the accumulator may be used by leaving the hose and Pressure gauge attached, but will not be as accurate, and should only be used if only full spool selection is being measured.)

Note: The accumulator may require recharging by running the engine for a short period).

Remove Spool cap from the main valve block and withdraw the spool checking for any scratches/imperfections, or any signs of sticking. Slide the spool in and out of the valve block, rotating it at the same time checking for smoothness.

Test 011: Testing Swing brake pressure

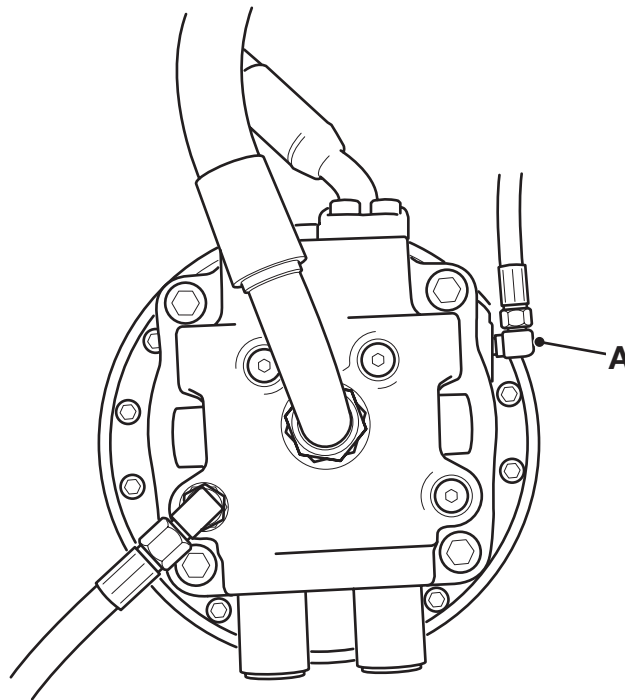

A405810-C1

Fig 22.

Fit pressure test gauge 0 - 60 bar (1000 lb in²) into hose connection on hose **A** on the Slew Motor.

Warm up hydraulic system to 50 °C

	Pressure at port A (expected pressure)
With engine at max rpm's no services selected record pressure	0 bar (0 lb in ²)
Select slew service record pressure	40 bar (580 lb in ²)
Deselect slew service and leave excavator pressure switch closed, record pressure	40 bar (580 lb in ²)
Select 100% slew lock record pressure	after 5 secs 0 - 1.5 bar (21.75lb in ²)

Note: Always stop the engine when installing or removing the dial gauge or reading the dial gauge.

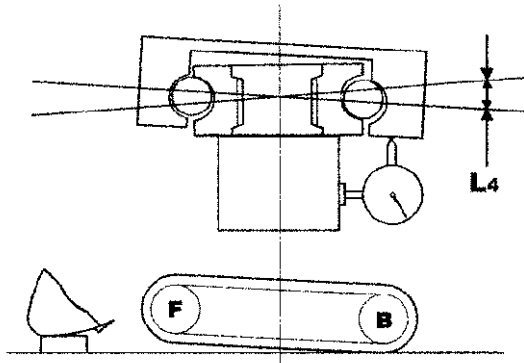

Fig 34.

- Next, place the dial gauge on the rear of the vehicle and repeat the two above procedures to obtain L2 and L4.

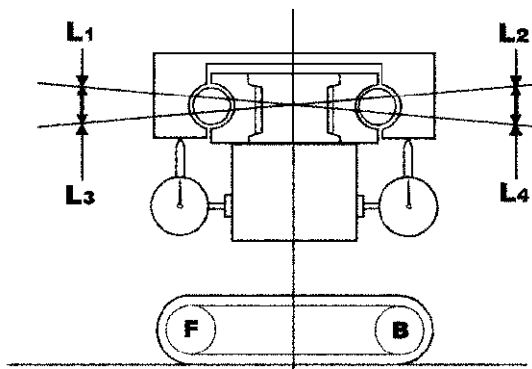

Fig 35.

- The average lateral movement is shown as the result of the equation

$$\frac{L1+L2+L3+L4}{2}$$

New Machine	Limit of Use
1.2 mm (0.05 in)	3.6 mm (0.15 in)

Replacement

- 1 Before fitting, clean the assembly.

Make sure that all ports are plugged to prevent the ingress of dirt.

- 2 Lift the assembly and position it on the undercarriage.

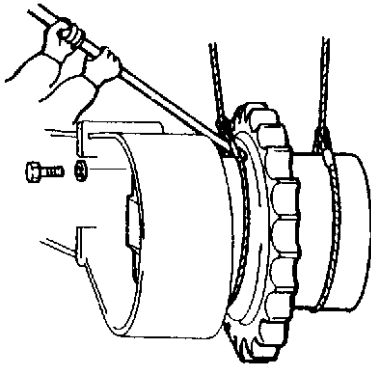

Fig 11.

Install the bolts and washers, using JCB Threadseal on the bolt threads. Tighten the bolts in a diagonal sequence.

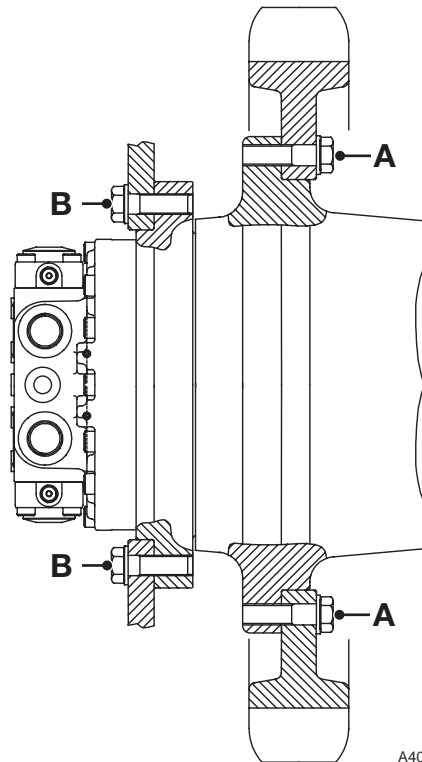

Fig 12.

Torque Settings

Item	Nm	lbf ft	kgf m
A	415	306	43
B	215	158.6	22

- 3 Remove the plugs and connect the motor hoses.

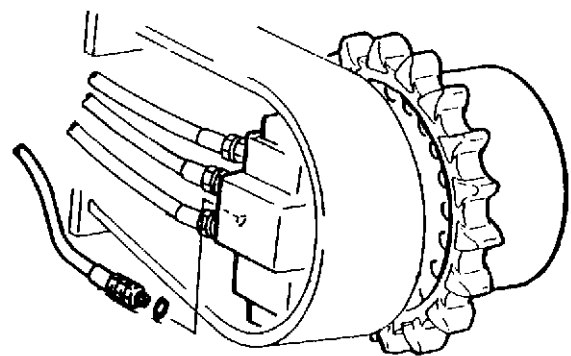

Fig 13.

Assembly

Assembly is a reversal of the Dismantling procedure. Numbers refer to the illustration, See [Fig 10.](#) (F-15).

Note: Exchange or repair all parts that are found to be damaged. In the case of a damaged planet gear, do not replace the single gear but the whole reduction stage.

Note: Ensure that all the parts are cleaned in the appropriate solvent and dried with compressed air.

Note: Apply a thin film of hydraulic fluid to all sliding parts, bearings and other contact surfaces before assembly.

Note: Replace all O-rings and seals and thoroughly clean the grooves that they sit in. Cover the O-rings and seals with petroleum jelly.

Half Seal Installation

- 1 Carefully clean the seats **A** and **B** using a small wire brush or solvent if necessary. The surfaces in contact with the O-ring **C** must be perfectly clean and dry.
- 2 Make sure that the sealing surfaces **D** of the metal rings are free from scratches and abrasions and foreign substances and are clean and dry.
- 3 Carefully clean the contact surface of the metal rings **E** and remove dust and fingerprints. Lubricate them with a thin film of oil. Take care not to oil the other components

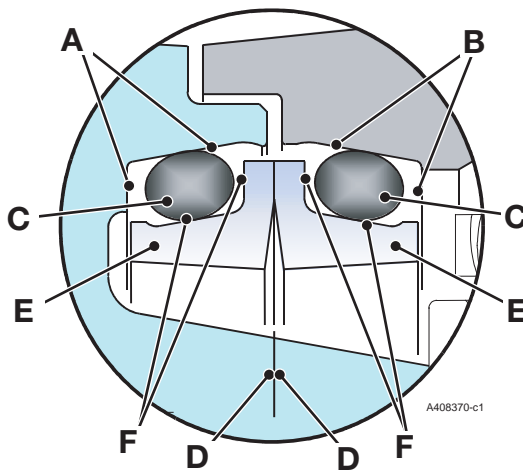

Fig 11.

- 1 Fit half seal 15, on resealing tool SST0037
- 2 Assemble, a half seal 16, on the hydraulic motor 18 by using service tool SST0037. Carefully clean the metal faces of the half seals.

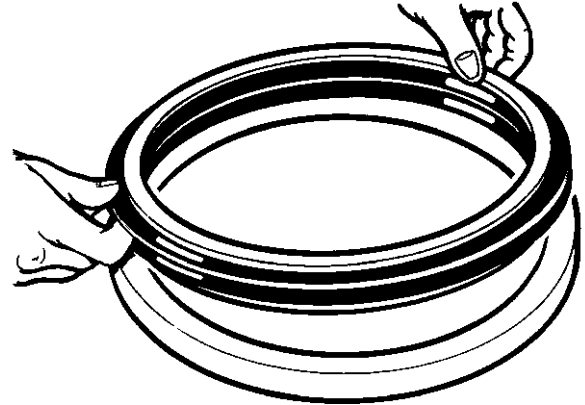

Fig 12.

- 3 Lubricate the metallic face of the half seal with a thin film of oil.
- 4 Assemble, a half seal 16, on the Gear Box housing 18 by using service tool SST0037. Carefully clean the metal faces of the half seals.

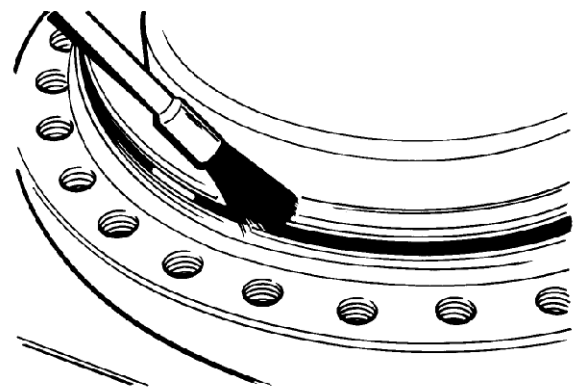

Fig 13.

- c Place the valve plate **21** on to the base plate **60**.

Note: The bronze layer surface must be upwards. i.e Facing away from the base plate.

- d Insert the pins **29** into the base plate **60**.
- e Place the base plate **60** on the flanged hub **1**.

Note: The base plate is centered by the two pins and the second speed oil passages must match.

- f Fix the base plate **60** to the flanged hub **1** by the nine socket head screws (M14) **63**. See Torque Settings .
- g Assemble the O-rings **62** in their seats in the plugs **61**, taking care not damage the O-ring on the thread of the plug. Tighten the plug into the base plate **60**. See Torque settings .
- h Tighten the restrictors orifices **58,59** into the base plate **60**. See Torque settings .
- i Tighten the restrictor orifice plug **57**. See Torque settings.
- j Tighten the restrictor orifice **64** in the base plate **60**. See Torque Settings. Using a punch, deform the thread to secure the restrictor.

4 Assemble the Counterbalance Spool Valve

- a Assemble the O-rings **36** in their seats in the flanged plugs **37**.
- b Insert the counterbalance spool **33**.
- c Insert the first spring seat **34** on to the counter balance valve spool **33**.
- d Insert the first spring **35** on to the counterbalance spool valve **33**.
- e Assemble the flanged plug assembly **38** on to the base plate **60** and tighten the four socket head screws **37**. See Torque settings.
- f Repeat steps 5c to 5e for the second assembly.

5 Relief Valve Assembly

- a Assemble the O-ring **44** in its seat in the relief valve **45**.
- b Assemble the first backup ring (A) **41** into it's seat in the free piston followed by the O-ring (B) **42** and then the second backup ring (C) **41** as shown below:

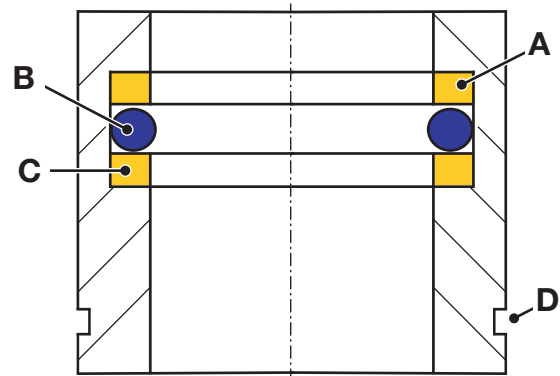

A408550-C1

Fig 3.

- c Insert the free piston in the relief valve **45** checking that the groove **D** is towards the inside of the motor.
- d Insert the relief valve **45** into the base plate **60** and tighten to the specified torque. See Torque settings.
- e Repeat steps 6a to 6d for the second relief valve.

6 Two Speed Spool

- a Assemble the O-rings **47** in it's seat in the plugs **46, 51**.
- b Tighten the plug **51**, see Torque Settings.
- c Insert the 2-speed spool **56** in the base plate **60**.

Note: Make sure the 2 speed spool **56** can move smoothly within the base plate **60**.

- d Insert the 2-speed spool spring **50** and its seats **48** into the end of the spool **56**.
- e Tighten the plug **46** into the base plate **60**. See Torque settings.

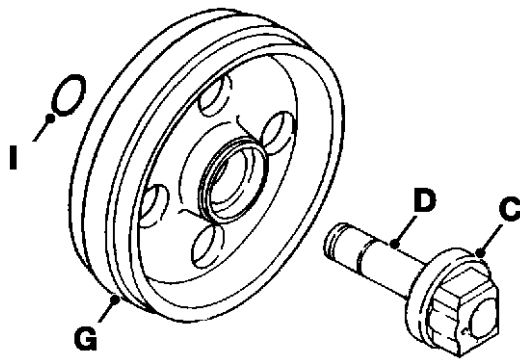

Fig 12.

- 6 Apply grease to a new 'O'-ring **I** and install it on the shaft **D**.

Clean the metallic face of the seal, coat the metallic face

with engine oil and install the hub **C** onto the shaft **D**. Fit new wire clip **E** or roll pin **F**.

Wrap sealing tape around the plug **A** with one thread remaining uncovered. Insert this plug but leave the other one out until after testing.

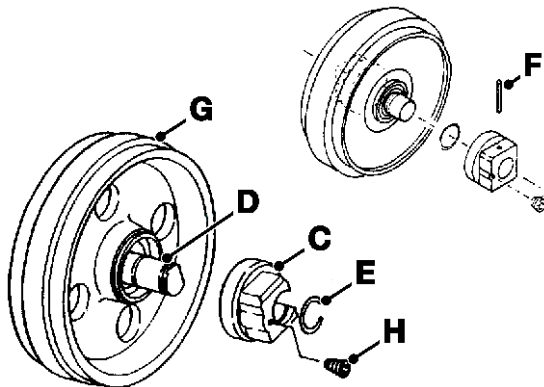

Fig 13.

- 7 Using extreme care to prevent water entering the assembly, lower it into a tank of water. Connect compressed air at **M** and apply pressure of 1.9 bar (28 lbf/in²). Check for air bubbles.

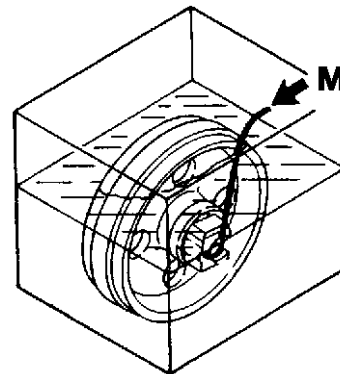

Fig 14.

- 8 Remove the assembly from the tank. Dry with compressed air. Add engine oil via plug **A** aperture. Install plug using an appropriate pipe sealant.

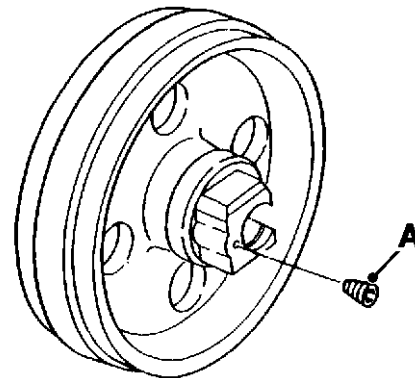

Fig 15.

- 9 Carry out steps 1 to 4 of Idler Wheel and Recoil Unit, Replacement.

Top Roller

Removal

- 1 Slacken the check valve to bleed out grease.

⚠ WARNING

When opening the check valve always stand to one side and loosen a little at a time until grease starts to come out. If you over-loosen too much grease could spurt out or the valve cover fly out and cause serious injury.

8-3-4-5

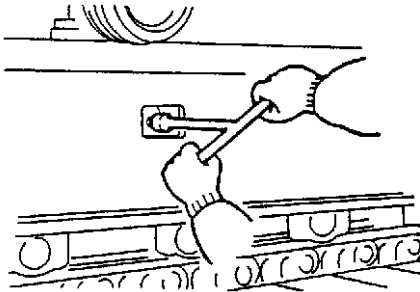

Fig 1.

- 2 Jack up the track high enough to permit roller removal. Put wooden blocks between track link and side frame.

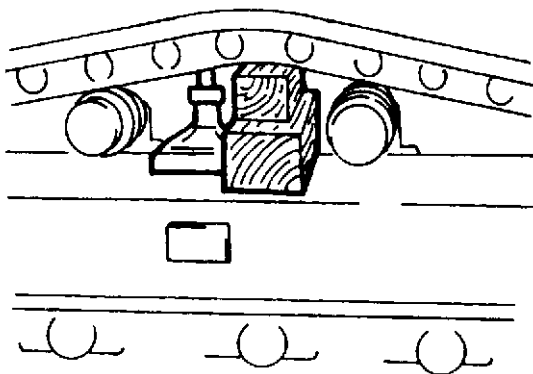

Fig 2.

- 3 Loosen but do not remove the mounting bolts. Tap the upper roller with a copper mallet to separate it from the side frame.

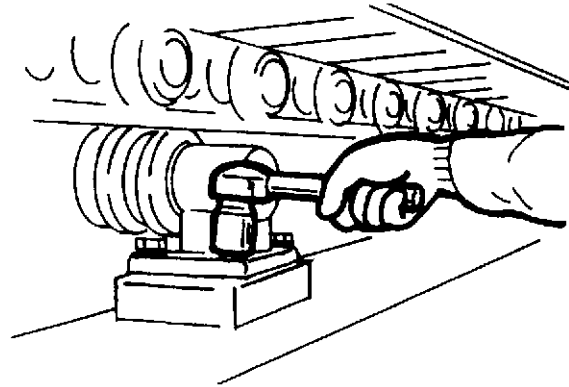

Fig 3.

- 4 Fasten a sling to the upper roller. Remove the mounting bolts and lift the upper roller clear.

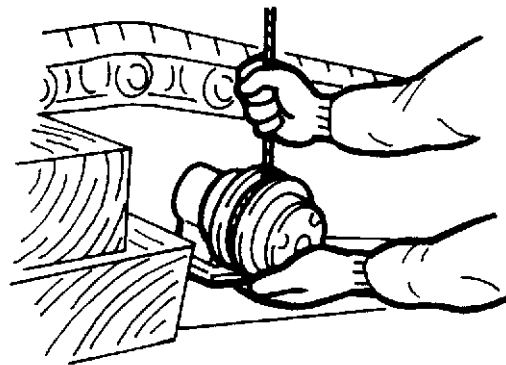

Fig 4.

CLICK HERE TO **DOWNLOAD** THE COMPLETE MANUAL

- Thank you very much for reading the preview of the manual.
- You can download the complete manual from: www.heydownloads.com by clicking the link below



- Please note: If there is no response to CLICKING the link, please download this PDF first and then click on it.

CLICK HERE TO **DOWNLOAD** THE COMPLETE MANUAL