

CONTENTS

Foreword	0-1	6. Traveling of the machine	4-14			
Before servicing this machine	0-2	7. Efficient working method	4-17			
EC regulation approved	0-3	8. Operation in the special work sites	4-21			
Table to enter S/No and distribution	0-4	9. Normal operation of excavator	4-23			
Safety labels	0-5	10. Attachment lowering	4-24			
Machine data plate	0-15	11. Storage	4-25			
Guide(Direction, S/No, Symbol)	0-16	12. RCV lever operating pattern	4-27			
		13. Switching hydraulic attachment circuit	4-28			
SAFETY HINTS						
1. Before operating the machine	1-1	TRANSPOTATION				
2. During operating the machine	1-6	1. Preparation for transportation	5-1			
3. During maintenance	1-13	2. Dimension and weight	5-2			
4. Parking	1-16	3. Loading the machine	5-4			
		4. Fixing the machine	5-6			
SPECIFICATIONS				5. Loading and unloading by crane	5-7	
1. Major components	2-1	MAINTENANCE				
2. Specifications	2-2	1. Instruction	6-1			
3. Working range	2-3	2. Tightening torque	6-6			
4. Weight	2-4	3. Fuel, coolant and lubricants	6-9			
5. Lifting capacities	2-5	4. Maintenance check list	6-11			
6. Bucket selection guide	2-8	5. Maintenance chart	6-16			
7. Undercarriage	2-10	6. Service instruction	6-18			
8. Specification for major components	2-12	7. Electrical system	6-42			
9. Recommended oils	2-16	8. Air conditioner and heater	6-45			
CONTROL DEVICES				TROUBLESHOOTING GUIDE		
1. Cab devices	3-1	1. Engine	7-1			
2. Cluster	3-2	2. Electrical system	7-2			
3. Switches	3-9	3. Others	7-3			
4. Levers and pedals	3-14	HYDRAULIC BREAKER				
5. Air conditioner and heater	3-16	1. Selecting hydraulic breaker	8-1			
6. Others	3-23	2. Circuit configuration	8-2			
OPERATION				3. Maintenance	8-3	
1. Suggestion for new machine	4-1	4. Precautions while operating the breaker	8-4			
2. Check before starting the engine	4-2	5. Quick clamp	8-6			
3. Starting and stop the engine	4-3	INDEX				9-1
4. Mode selection system	4-6					
5. Operation of the working device	4-13					

CLICK HERE TO **DOWNLOAD** THE COMPLETE MANUAL

- Thank you very much for reading the preview of the manual.
- You can download the complete manual from: www.heydownloads.com by clicking the link below



- Please note: If there is no response to CLICKING the link, please download this PDF first and then click on it.

CLICK HERE TO **DOWNLOAD** THE COMPLETE MANUAL

13) SHEARING-ENGINE HOOD(Item 17)

This warning label is positioned on the engine hood.

- ▲ Do not open the engine hood during the engine's running.
- ▲ Do not touch exhaust pipe or it may cause severe burn.

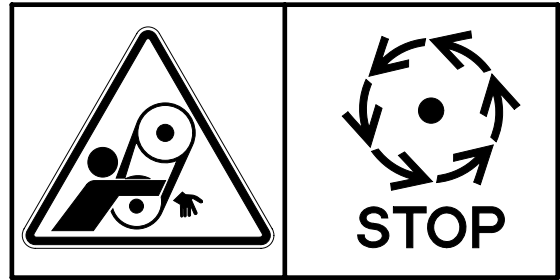

21070FW15

14) NO STEP-ENGINE HOOD(Item 18)

This warning label is positioned on the engine hood.

- △ Do not step on the engine hood.

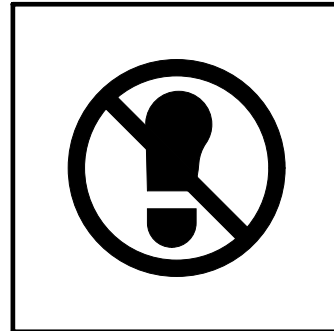

21070FW16

15) TRANSPORTING(Item 19)

This warning label is positioned right side of upper frame.

- ▲ Study the operator's manual before transporting the machine, if provided and tie down arm and track to the carrier with lashing wire.
- ※ See page 5-6 for details.

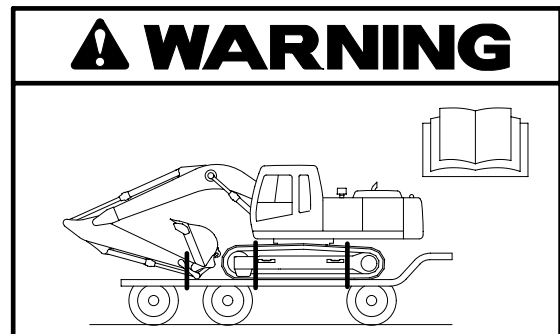

14070FW17

16) CONTROL IDEOGRAM(Item 21)

This warning label is positioned in right window of the cab.

- ▲ Check the machine control pattern for conformance to pattern on this label. If not, change label to match pattern before operating machine.
- ▲ Failure to do so could result in injury or death.
- ※ See page 4-13 for details.

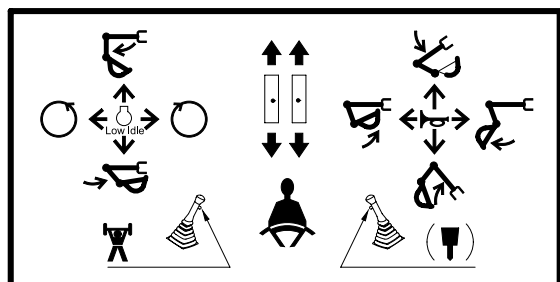

36070FW19

ROTATING BEACON

When you operate a machine on a road or beside a road, a rotating beacon is required to avoid any traffic accident.

Please contact your Hyundai distributor to install it.

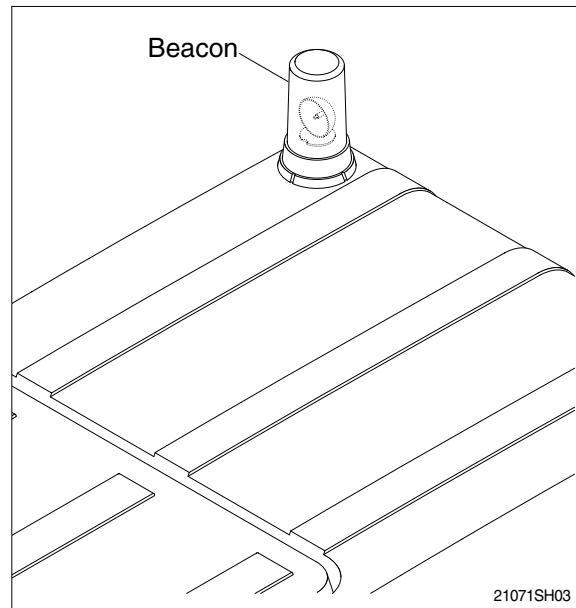

PRECAUTIONS FOR ATTACHMENTS

When installing and using an optional attachment, read the instruction manual for the attachment and the information related to attachments in this manual.

Do not use attachments that are not authorized by Hyundai or your Hyundai distributor. Use of unauthorized attachments could create a safety problem and adversely affect the proper operation and useful life of the machine.

Any injuries, accidents, product failures resulting from the use of unauthorized attachments are not the responsibility of Hyundai.

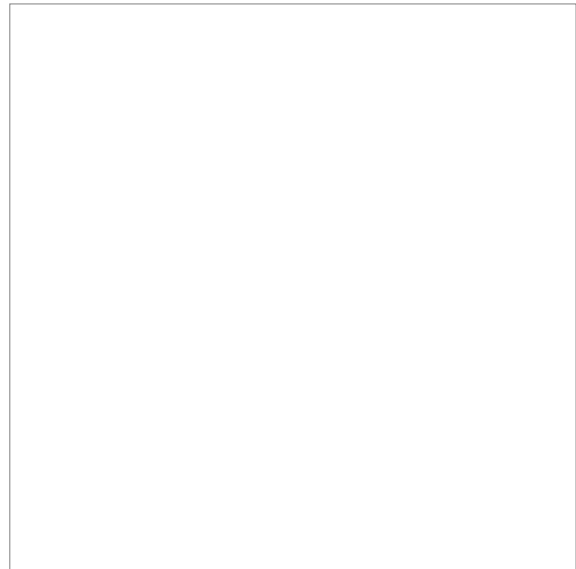

SAFETY RULES

Only trained and authorized personnel can operate and maintain the machine.

Follow all safety rules, precautions and instructions when operating or performing maintenance on the machine.

When working with another operator or a person on worksite traffic duty, be sure all personnel understand all hand signals that are to be used.

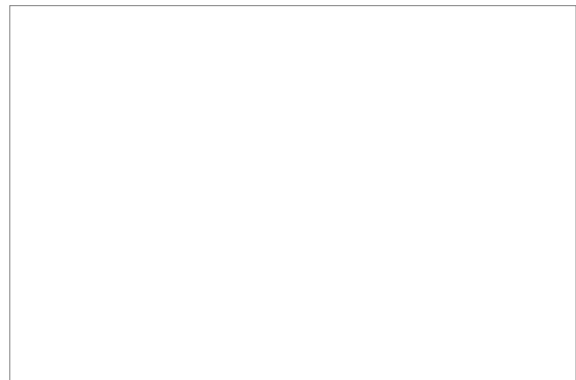

There is the danger of fire in fuel and oil.
Store in cool and dry area, away from any open flames.

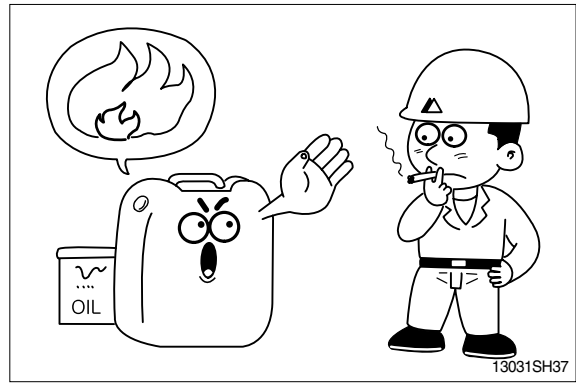

Do not touch exhaust pipe, or may cause severe burn.

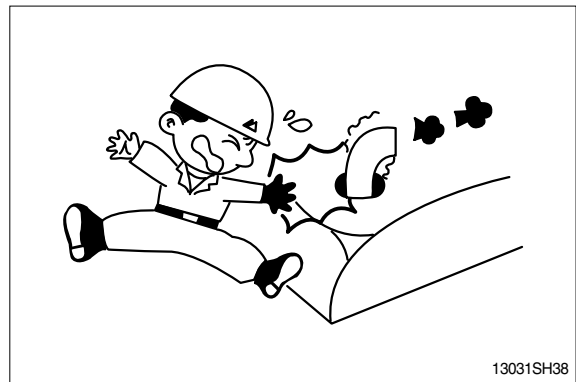

Do not open the engine hood and covers while the engine is running.



Be careful of not hitting the edges when you service engine.

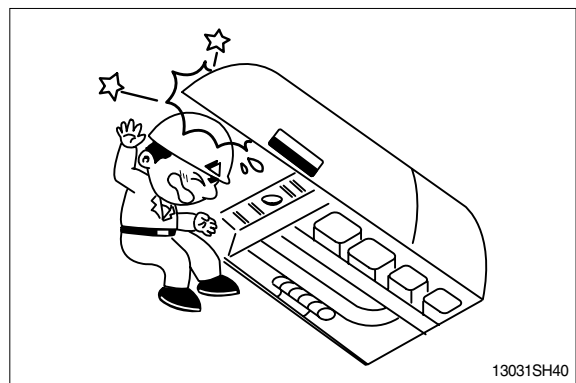

2) R320LC-7A HIGH WALKER

Item	R320LC-7A HIGH WALKER	
	kg	lb
Upperstructure assembly	14520	31590
Main frame weld assembly	2680	5900
Engine assembly	590	1300
Main pump assembly	180	380
Main control valve assembly	200	440
Swing motor assembly	310	680
Hydraulic oil tank assembly	230	490
Fuel tank assembly	210	450
Counterweight	6200	13670
Cab assembly	310	680
Radiator total assy	280	620
Lower chassis assembly	13360	29450
Track frame weld assembly	5825	12840
Swing bearing	410	900
Travel motor assembly	390	860
Turning joint	50	110
Tension cylinder	210	450
Idler	250	540
Sprocket	80	170
Carrier roller	40	80
Track roller	60	120
Track-chain assembly(600mm standard triple grouser shoe)	1860	4100
Front attachment assembly(6.45m boom, 3.2m arm, 1.44m ³ SAE heaped bucket)	6390	14090
6.45m boom assembly	2530	5580
3.2m arm assembly	1160	2560
1.44m ³ SAE heaped bucket	1120	2470
Boom cylinder assembly	280	620
Arm cylinder assembly	380	840
Bucket cylinder assembly	270	570
Bucket control linkage assembly	370	820

(2) 6.45m(21' 2") boom, 2.2m(7' 3") arm equipped with 1.44m³(SAE heaped) bucket and 600mm (24") triple grouser shoe and 6200kg(13670lb) counterweight.

Load point height		Load radius								At max. reach		
		3.0m(10.0ft)		4.5m(15.0ft)		6.0m(20.0ft)		7.5m(25.0ft)		Capacity		Reach
												m(ft)
7.5m (25.0ft)	kg lb									*6560 *14460	5750 12680	8.27 (27.1)
6.0m (20.0ft)	kg lb					*7790 *17170	*7790 *17170	*7160 *15790	6690 14750	*6620 *14590	4760 10490	9.07 (29.8)
4.5m (15.0ft)	kg lb			*12070 *26610	*12070 *26610	*9100 *20060	*9100 *20060	*7740 *17060	6480 14290	6310 13910	4250 9370	9.53 (31.3)
3.0m (10.0ft)	kg lb					*10580 *23320	8810 19420	*8490 *18720	6220 13710	6030 13290	4030 8880	9.71 (31.9)
1.5m (5.0ft)	kg lb					*11750 *25900	8400 18520	8960 19750	5990 13210	6060 13360	4040 8910	9.62 (31.6)
Ground Line	kg lb			*17060 *37610	12870 28370	*12310 *27140	8190 18060	8810 19420	5850 12900	6440 14200	4290 9460	9.25 (30.3)
-1.5m (-5.0ft)	kg lb	*15230 *33580	*15230 *33580	*16370 *36090	12940 28530	*12160 *26810	8160 17990	8790 19380	5830 12850	7320 16140	4910 10820	8.56 (28.1)
-3.0m (-10.0ft)	kg lb	*19910 *43890	*19910 *43890	*14770 *32560	13190 29080	*11100 *24470	8300 18300			*7210 *15900	6270 13820	7.45 (24.4)
-4.5m (-15.0ft)	kg lb			*11560 *25490	*11560 *25490							

(3) 6.45m(21' 2") boom, 2.5m(8' 2") arm equipped with 1.44m³(SAE heaped) bucket and 600mm (24") triple grouser shoe and 6200kg(13670lb) counterweight.

Load point height		Load radius									At max. reach			
		3.0m(10.0ft)		4.5m(15.0ft)		6.0m(20.0ft)		7.5m(25.0ft)		9.0m(30.0ft)		Capacity		Reach
7.5m (25.0ft)	kg lb											*6190 *13650	5470 12060	8.53 (28.0)
6.0m (20.0ft)	kg lb							*6830 *15060	6730 14840			*6290 *13870	4560 10050	9.31 (30.5)
4.5m (15.0ft)	kg lb			*11350 *25020	*11350 *25020	*8700 *19180	*8700 *19180	*7440 *16400	6490 14310			6070 13380	4080 8990	9.76 (32.0)
3.0m (10.0ft)	kg lb			*14550 *32080	13750 30310	*10220 *22530	8840 19490	*8230 *18140	6210 13690	6800 14990	4550 10030	5790 12760	3860 8510	9.93 (32.6)
1.5m (5.0ft)	kg lb			*16520 *36420	12990 28640	*11480 *25310	8380 18470	8930 19690	5960 13140			5810 12810	3850 8490	9.84 (32.3)
Ground Line	kg lb			*17000 *37480	12760 28130	*12160 *26810	8130 17920	8750 19290	5790 12760			6140 13540	4080 8990	9.48 (31.1)
-1.5m (-5.0ft)	kg lb	*15490 *34150	*15490 *34150	*16510 *36400	12790 28200	*12150 *26790	8060 17770	8710 19200	5750 12680			6930 15280	4620 10190	8.82 (28.9)
-3.0m (-10.0ft)	kg lb	*20890 *46050	*20890 *46050	*15120 *33330	13010 28680	*11300 *24910	8180 18030					*7250 *15980	5800 12790	7.75 (25.4)
-4.5m (-15.0ft)	kg lb	*16640 *36680	*16640 *36680	*12290 *27090	*12290 *27090									

7) REMOTE CONTROL VALVE

Item		Specification
Type		Pressure reducing type
Operating pressure	Minimum	6.5kgf/cm ² (92psi)
	Maximum	26kgf/cm ² (370psi)
Single operation stroke	Lever	61mm(2.4in)
	Pedal	123mm(4.84in)

8) CYLINDER

Item		Specification
Boom cylinder	Bore dia × Rod dia × Stroke	∅ 150 × ∅ 105 × 1480mm
	Cushion	Extend only
Arm cylinder	Bore dia × Rod dia × Stroke	∅ 160 × ∅ 110 × 1685mm
	Cushion	Extend and retract
Bucket cylinder	Bore dia × Rod dia × Stroke	∅ 140 × ∅ 100 × 1285mm
	Cushion	Extend only

※ Discoloration of cylinder rod can occur when the friction reduction additive of lubrication oil spreads on the rod surface.

※ Discoloration does not cause any harmful effect on the cylinder performance.

9) SHOE

Item		Width	Ground pressure	Link quantity	Overall width
R320LC-7A	Standard	☆600mm(24")	0.62kgf/cm ² (8.82psi)	48	3280mm(10' 9")
	Option	☆700mm(28")	0.54kgf/cm ² (7.68psi)	48	3380mm(11' 1")
		☆800mm(32")	0.48kgf/cm ² (6.83psi)	48	3480mm(11' 5")
		☆900mm(36")	0.43kgf/cm ² (6.11psi)	48	3580mm(11' 9")
R320NLC-7A	Standard	☆600mm(24")	0.61kgf/cm ² (8.67psi)	48	2990mm(9' 10")
R320LC-7A H/WALKER	Standard	☆600mm(24")	0.67kgf/cm ² (9.53psi)	48	3470mm(11' 5")
	Option	☆700mm(28")	0.58kgf/cm ² (8.25psi)	48	3570mm(11' 9")
		☆800mm(32")	0.51kgf/cm ² (7.25psi)	48	3670mm(12' 0")
		★710mm(28")	0.58kgf/cm ² (8.25psi)	48	3580mm(11' 9")

☆ : Triple grouser

★ : Double grouser

(3) Auto deceleration switch

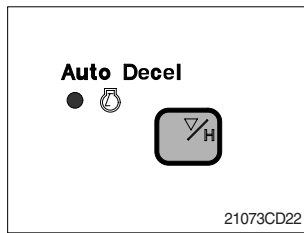

① This switch is used to actuate or cancel the auto deceleration function.

When the switch actuated and all control levers and pedals are at neutral position, engine speed will be lowered automatically to save fuel consumption.

- Light ON : Auto deceleration function is selected.
- Light OFF : Auto deceleration function is cancelled so that the engine speed increased to previous setting value.

② Operating the auto deceleration function makes the decel indicating lamp on the LCD panel ON.

(4) Power mode switch

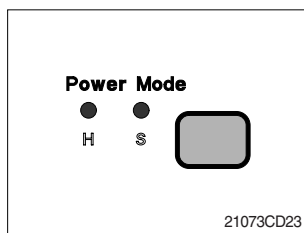

① The lamp of selected mode is turned ON by pressing the switch().

- H : High power work.
- S : Standard power work.

(5) Travel speed control switch

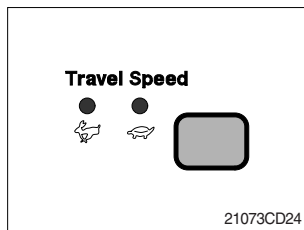

① This switch is to control the travel speed which is changed to high speed(Rabbit mark) by pressing the switch and low speed(Turtle mark) by pressing it again.

(6) Buzzer stop switch

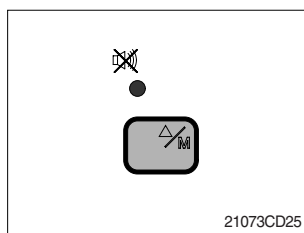

① When the starting switch is turned ON first, normally the alarm buzzer sounds for 2 seconds during lamp check operation.

② The red lamp lights ON and the buzzer sounds when the machine has a problem.

In this case, press this switch and buzzer stops, but the red lamp lights until the problem is cleared.

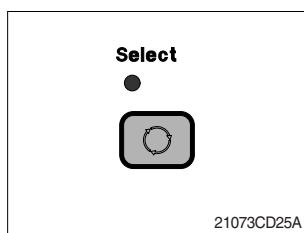

(7) Select switch



① This switch is used to select the monitor display function.

※ Refer to the page 4-11 for details.

② If the switch is pressed for 3 seconds in time display mode, it moves to time adjusting function, and you can adjust the time as below.

- Hour by auto decel()switch
- Minute by buzzer stop() switch.

③ After time set, the switch is pressed, it returns to clock display.

6) SWITCH PANEL

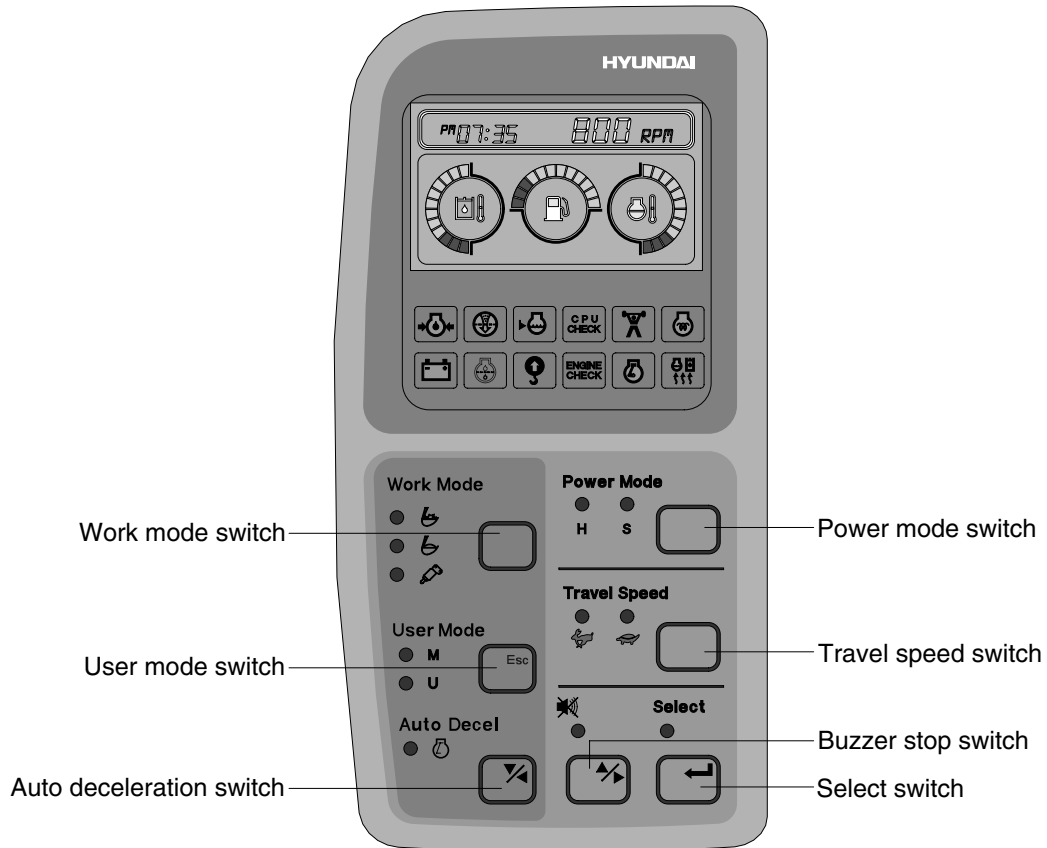

1607A3CD19

- ※ When the switches (Work mode, Power mode, Auto decel, Travel speed control) are selected, the pop-up icon is displayed on the LCD.
Refer to the page 3-4 for details.

(1) Work mode switch

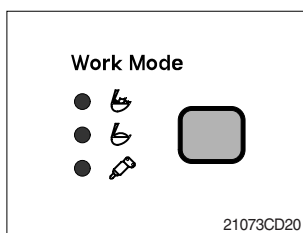

- ① This switch is to select the machine operation mode, which shifts from general operation mode to heavy operation mode and breaker mode in a row by pressing the switch.

- : Heavy duty work mode
- : General work mode
- : Breaker operation mode

※ Refer to the page 4-6, 4-12-1 for details.

(2) User mode switch

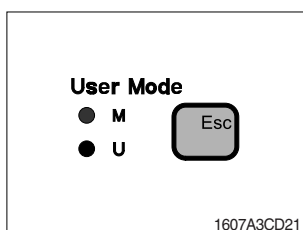

- ① This switch is to select the maximum power or user mode.

- M : Maximum power
- U : Memorizing operators preferable power setting.

※ Refer to the page 4-6, 4-12-1 for details.

1) POWER SWITCH

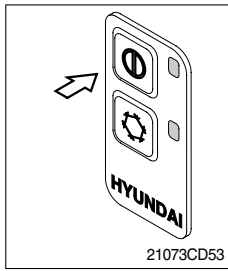

(1) This switch makes the system and the LED simultaneously ON or OFF.

(2) Default setting values

Function	Air conditioner	Fan speed	Temperature	Outlet	Inlet
Value	OFF	1	Max cool	Face	Recirculation

2) AIR CONDITIONER SWITCH(Compressor switch)

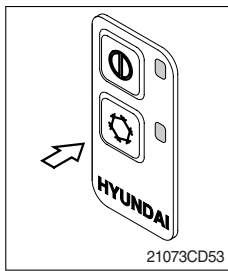

(1) Operating this switch turns the compressor and the LED simultaneously ON or OFF.

(2) In accordance with the evaporator temperature, compressor turns on or off automatically without changing LED state.

※ **Air conditioner operates to remove vapor and drains water through a drain hose. Water can be sprayed into the cab in case that the vacuum valve of drain hose has a problem. In this case, exchange the vacuum valve.**

3) FAN SPEED SWITCH

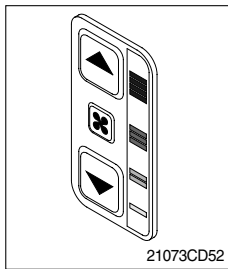

(1) It is possible to control the fan to four steps.

(2) The first step or the fourth step gives 5 times beeps.

4) TEMPERATURE CONTROL SWITCH

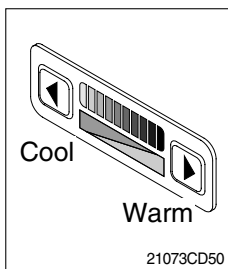

(1) There are 9 steps to control temperature from max cool to max warm controlled up and down by 1 step.

(2) Max cool and max warm arouse 5 times beeps.

(3) For the max warm or the max cool it's better to be configured as following table.

Temperature	Air conditioner	Fan speed	Outlet	Inlet
Max cool	ON	4	Face	Recirculation
Max warm	OFF	3	Foot	Fresh

CLICK HERE TO **DOWNLOAD** THE COMPLETE MANUAL

- Thank you very much for reading the preview of the manual.
- You can download the complete manual from: www.heydownloads.com by clicking the link below



- Please note: If there is no response to CLICKING the link, please download this PDF first and then click on it.

CLICK HERE TO **DOWNLOAD** THE COMPLETE MANUAL

11) J1939 SERIAL CONNECTOR

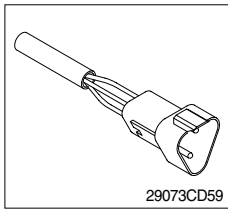

(1) ECM communicates the engine data with cummins INLINE-II adapter through J1939 connector.

- ① ECM fault code check
- ② ECM program change
- ③ Engine data monitoring & test

12) UPPER WINDSHIELD

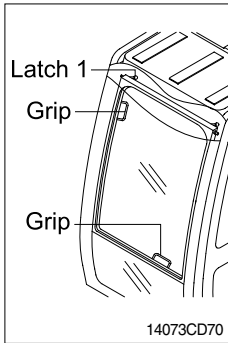

(1) Perform the following procedure in order to open the upper windshield.

- ① Release both latches(1) in order to release the upper windshield.
- ② Hold both grips that are located at the bottom of the windshield frame and at the top of the windshield frame push the windshield upward.
- ③ Hold both grips that are provided on the windshield frame and back into the storage position until auto lock latch(2) is engaged, move the levers of both latches(1) into the locked position. Push the levers toward the rear of the cab in order to hold the windshield in storage position.

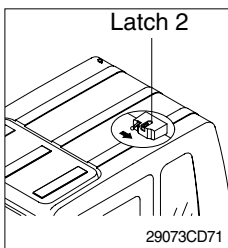

(2) Perform the following procedure in order to close the upper windshield.

- ① Move the lever of the auto lock latch(2) in the direction of the arrow in order to release the auto lock latch.
- ② Reverse step ① through step ③ in order to close the upper windshield.

1. SUGGESTION FOR NEW MACHINE

- 1) It takes about 100 operation hours to enhance its designed performance.
- 2) Operate according to below three steps and avoid excessive operation for the initial 100 hours.

Service meter	Load
Until 10 hours	About 60%
Until 100 hours	About 80%
After 100 hours	100%

※ **Excessive operation may deteriorate the potential performance of machine and shorten lifetime of the machine.**

3) Be careful during the initial 100 hours operation

- (1) Check daily for the level and leakage of coolant, engine oil, hydraulic oil and fuel.
- (2) Check regularly the lubrication and fill grease daily all lubrication points.
- (3) Tighten bolts.
- (4) Warm up the machine fully before operation.
- (5) Check the gauges occasionally during the operation.
- (6) Check if the machine is operating normally during operation.

4) Replace followings after initial 50 hours of operation

Checking items	Service
Engine oil	Replace
Engine oil filter element	
Hydraulic oil return filter element	
Hydraulic oil tank drain filter cartridge	
Line filter element	
Fuel filter	

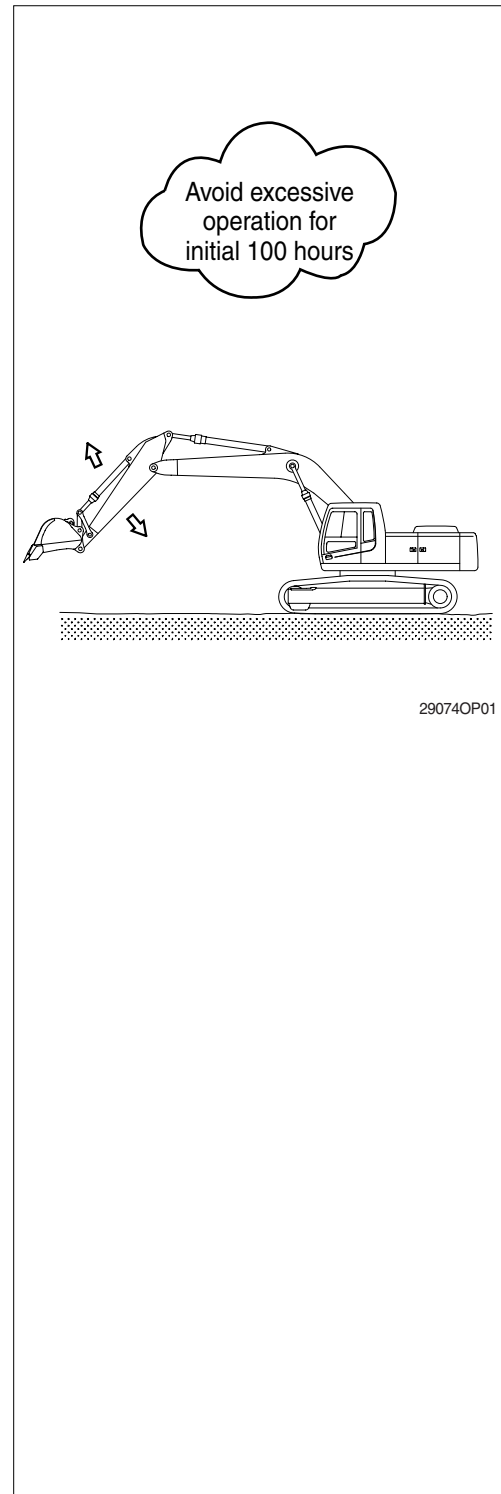

(6) Monitoring system

Information of machine performance as monitored by the MCU controller can be displayed on the **monitoring display**.

※ Refer to 4-11 page for details.

(7) Self diagnostic system

① MCU controller

The MCU controller diagnoses problems in the CAPO system caused by electric parts' malfunction and by open or short circuit, which are displayed on the **monitoring display** as error codes(2digit).

※ Consult hyundai or hyundai dealer for details.

② Engine controller(ECM)

If the engine or relevant system has problem ECM diagnoses and displays on the monitoring display as fault codes(3 digit).

※ Consult hyundai or hyundai dealer for details.

(8) Anti-restart system

The system protects the starter from inadvertent restarting after the engine is already operational.

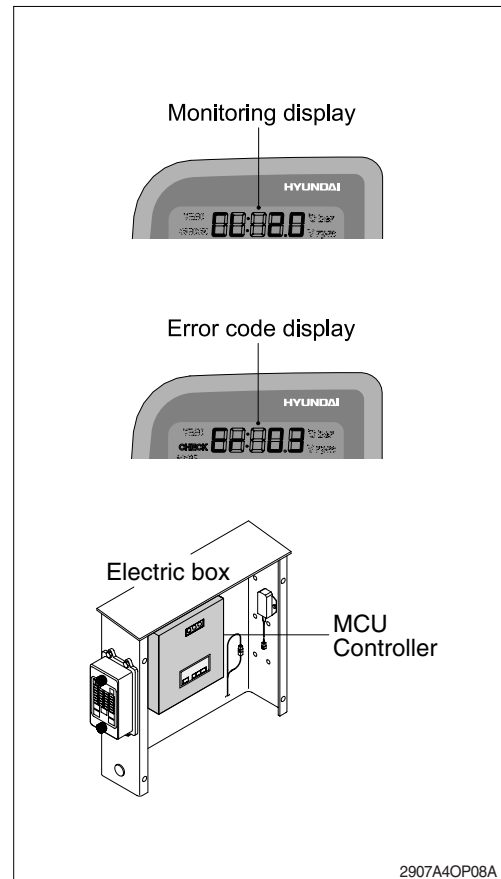

2) HOW TO OPERATE MODE SELECTION SYSTEM

(1) When start key is turned ON

① When start key is turned ON, all illumination lamps are ON and all lamps are OFF automatically after 5 seconds. But a battery charging warning lamp and an engine oil pressure warning lamp keep turned ON until engine starting.

② After lamp check 「CL : 2.0」, the version of cluster program, is displayed on **Monitoring display** for 2 seconds.

③ After the version of program is displayed, the cluster returns to default. Exactly engine rpm, battery charging warning lamp and engine oil pressure warning lamp are turned ON and S mode, auto decel, low travel speed(Turtle mark) are displayed.

④ In default condition self-diagnostic function including trouble detecting of electric system can be carried out.

※ Refer to 4-11 page for details.

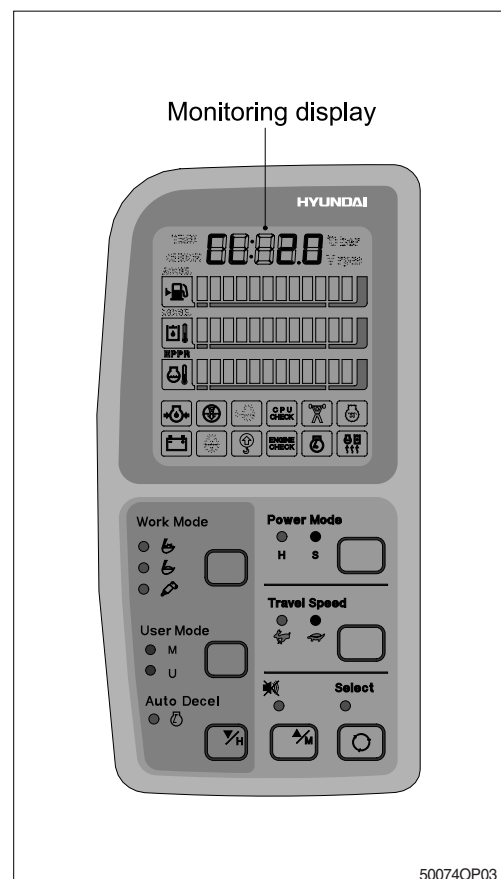

5. OPERATION OF WORKING DEVICE

※ **Confirm the operation of control lever and working device.**

- 1) Left control lever controls arm and swing.
- 2) Right control lever controls boom and bucket.
- 3) When you release the control lever, control lever returns to neutral position automatically.

※ **When operating swing, consider the swing distance by inertia.**

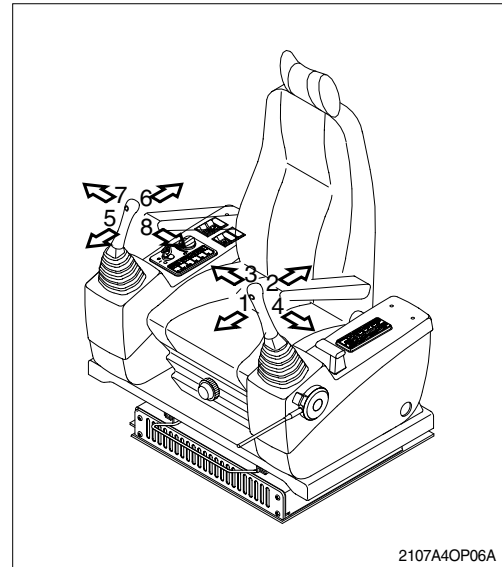

21074OP06A

※ **Left control lever**

- 1 Arm roll-out
- 2 Arm roll-in
- 3 Swing right
- 4 Swing left

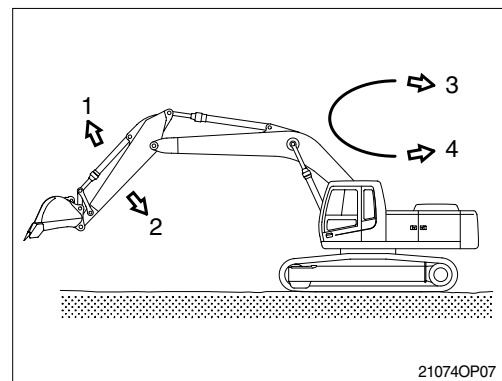

21074OP07

※ **Right control lever**

- 5 Boom lower
- 6 Boom raise
- 7 Bucket roll-out
- 8 Bucket roll-in

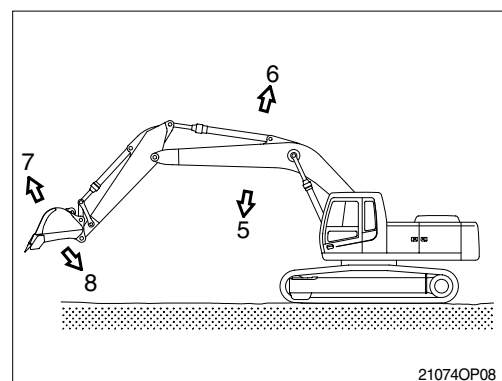

21074OP08

9. NORMAL OPERATION OF EXCAVATOR

Followings may occur during operation due to the nature of a hydraulic excavator.

- 1) When rolling in the arm, the roll-in movement stop momentary at point **X** in the picture shown, then recovers speed again after passing point **X**.
The reason for this phenomenon is that movement by the arm weight is faster than the speed of oil flow into the cylinder.
- 2) When lowering the boom, one may hear continuous sound.
This is caused by oil flow in the valve.
- 3) Overloaded movement will produce sound caused by the relief valves, which are for the protection of the hydraulic systems.
- 4) When the machine is started swing or stopped, a noise near the swing motor may be heard. The noise is generated when the brake valve relieves.

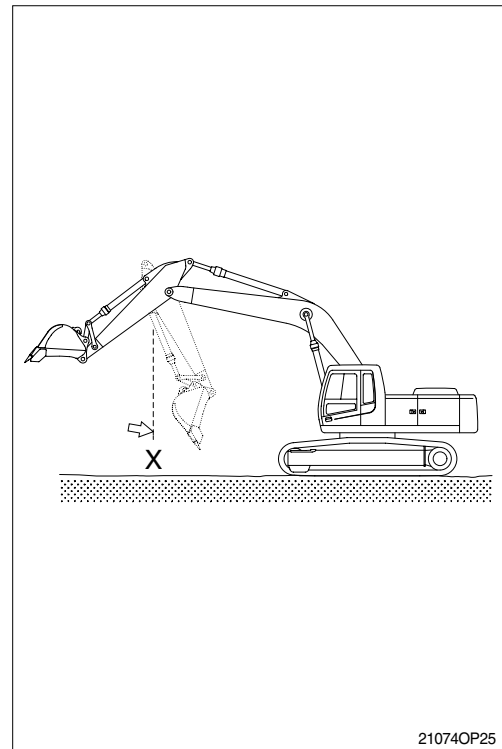

3. LOADING THE MACHINE

- 1) Load and unload the machine on a flat ground.
- 2) Use the gangplank with sufficient length, width, thickness and gradient.
- 3) Place the swing lock lever to the LOCK position before fixing the machine at the bed of trailer and confirm if the machine parallels the bed of trailer. Keep the travel motor in the rear when loading and in the front when unloading.

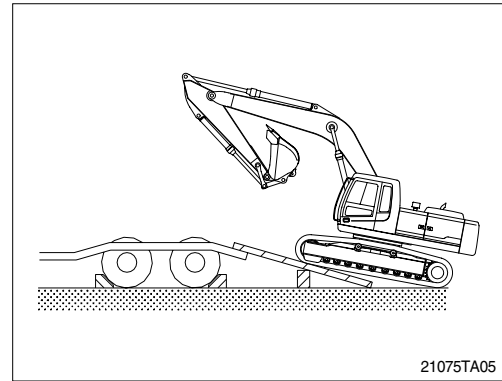

- 4) Do the following after loading the machine to the trailer.
 - (1) Stop loading when the machine is located horizontally with the rear wheel of trailer.

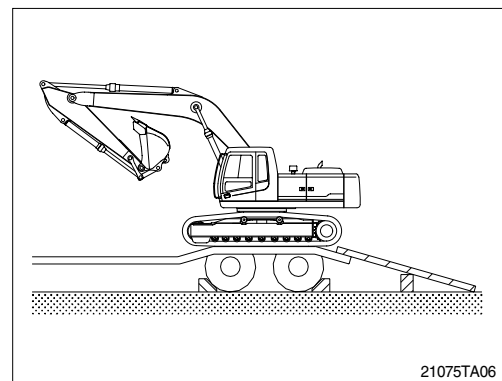

- (2) Place the swing lock lever to the LOCK position after the swing the machine 180 degree.

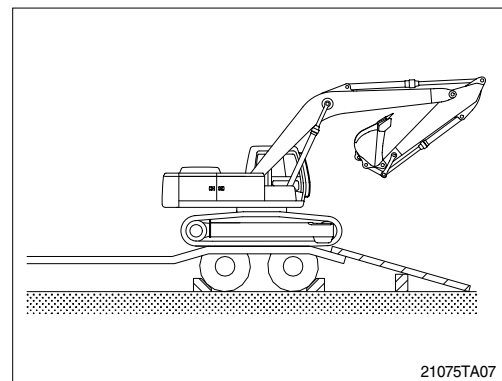

2) PIPE AND HOSE(FLARE TYPE)

Thread size(PF)	Width across flat(mm)	kgf · m	lbf · ft
1/4"	19	4	28.9
3/8"	22	5	36.2
1/2"	27	9.5	68.7
3/4"	36	18	130
1"	41	21	152
1-1/4"	50	35	253

3) PIPE AND HOSE(ORFS TYPE)

Thread size(UNF)	Width across flat(mm)	kgf · m	lbf · ft
9/16-18	19	4	28.9
11/16-16	22	5	36.2
13/16-16	27	9.5	68.7
1-3/16-12	36	18	130
1-7/16-12	41	21	152
1-11/16-12	50	35	253

4) FITTING

Thread size	Width across flat(mm)	kgf · m	lbf · ft
1/4"	19	4	28.9
3/8"	22	5	36.2
1/2"	27	9.5	68.7
3/4"	36	18	130
1"	41	21	152
1-1/4"	50	35	253

Service interval	No.	Description	Service action	Oil symbol	Capacity l (U.S.gal)	Service points No.
10 Hours or daily	1	Hydraulic oil level	Check, Add	HO	210(55.5)	1
	2	Engine oil level	Check, Add	EO	35(9.2)	1
	4	Radiator coolant	Check, Add	C	45(12)	1
	5	Prefilter(Water, element)	Check, Clean	-	-	1
	6	Fan belt tension & damage	Check, Clean	-	-	1
	25	Fuel tank	Check, Refill	DF	480(126.8)	1
50 Hours or weekly	7	Attachment pins	Check, Add	PGL	-	17
	8	Fuel tank(Water, element)	Check, Clean	-	-	1
	9	Swing bearing	Check, Add	PGL	-	3
	10	Swing reduction gear case	Check, Add	GO	7.0(1.8)	3
	12	Track tension	Check, Adjust	PGL	-	2
250 Hours	13	Battery(Electrolyte)	Check, Add	-	-	2
	14	Hydraulic oil return filter(-#0151)	Replace	-	-	2
	15	Drain filter cartridge(-#0151)	Replace	-	-	1
	16	Air breather element	Replace	-	-	1
	18	Line filter element(-#0151)	Replace	-	-	1
	19	Aircon & heater recirculation filter	Check, Clean	-	-	1
500 Hours	2	Engine oil level	Change	EO	35(9.2)	1
	3	Engine oil filter	Replace	-	-	1
	5	Prefilter(Water, element)	Replace	-	-	1
	20	Air cleaner element(Primary)	Clean	-	-	1
	21	Fuel filter element	Replace	-	-	1
	22	Radiator, oil cooler, charger air cooler	Clean	-	-	1
	23	Corrosion resistor	Replace	-	-	1
1000 Hours	10	Swing reduction gear case	Change	GO	7.0(1.8)	1
	11	Swing gear and pinion	Change	PGL	10.1kg(22.3lb)	1
	14	Hydraulic oil return filter(#0152-)	Replace	-	-	2
	15	Drain filter cartridge(#0152-)	Replace	-	-	1
	18	Line filter element(#0152-)	Replace	-	-	1
	24	Travel reduction gear case	Change	GO	11.0(2.9)	2
	25	Swing reduction gear grease(#0369-)	Change	PGL	1.8(0.5)	1
2000 Hours	1	Hydraulic oil level	Change	HO	210(55.5)	1
	4	Radiator coolant	Change	C	45(12)	1
	17	Hydraulic oil suction strainer	Check, Clean	-	-	1
As required	19	Aircon & heater recirculation filter	Clean, Replace	-	-	1
	19	Aircon & heater fresh filter	Clean, Replace	-	-	1
	20	Air cleaner element(Safety)	Replace	-	-	1
	20	Air cleaner element(Primary)	Replace	-	-	1

※ Oil symbol

Please refer to the recommended lubricants for specification.

DF : Diesel fuel GO : Gear oil HO : Hydraulic oil
C : Coolant PGL : Grease EO : Engine oil

10) BELT TENSIONER, AUTOMATIC ADJUSTMENT

- (1) Every 1000hours, or 1 year, whichever occurs first, inspect the automatic belt tensioner.

With the engine turned off, check that neither the top nor bottom tensioner arm stop is touching the cast boss on the tensioner body. If either of the stops is touching a boss, the alternator belt must be replaced. Check to make sure the correct belt part number is being used if either condition exists.

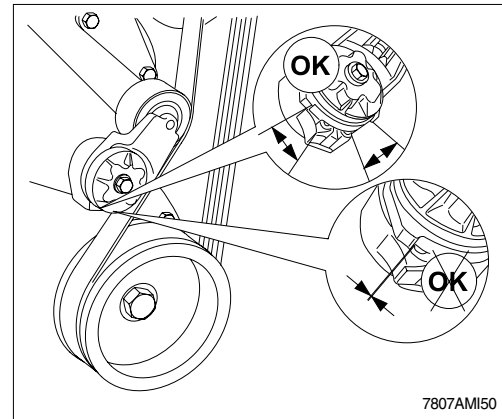

- (2) Check the tensioner pulley and body for cracks. If any cracks are noticed, the tensioner must be replaced. Refer to a Cummins Authorized Repair facility. Check the tensioner for dirt buildup. If this condition exists, the tensioner must be removed and steam-cleaned.

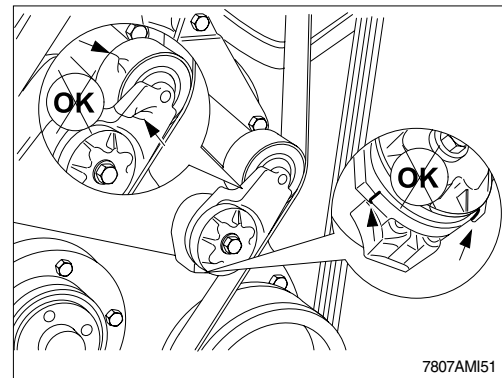

- (3) Check that the bottom tensioner arm stop is in contact with the bottom tensioner arm stop boss on the tensioner body. If these two are not touching, the tensioner must be replaced.

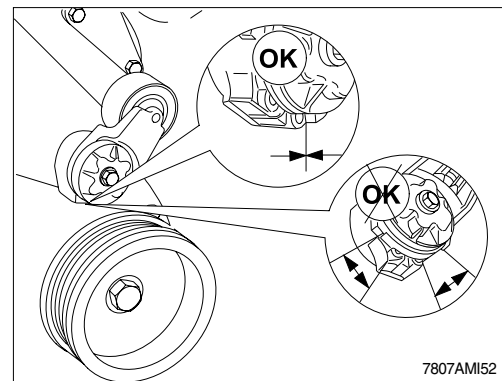

- (4) Inspect the tensioner for evidence of the pivoting tensioner arm contacting the stationary circular base. If there is evidence of these two areas touching, the pivot tube bushing has failed and the tensioner must be replaced.

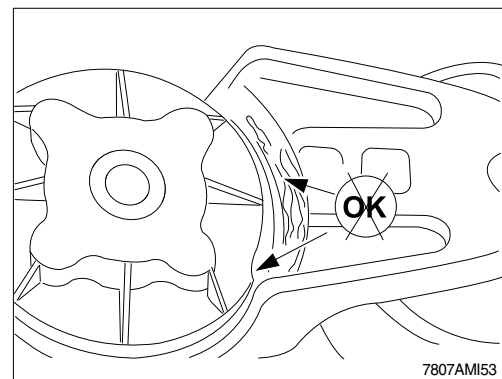

31) LUBRICATE RCV LEVER

Remove the bellows and with a grease gun grease the joint part(A) and sliding parts(B).

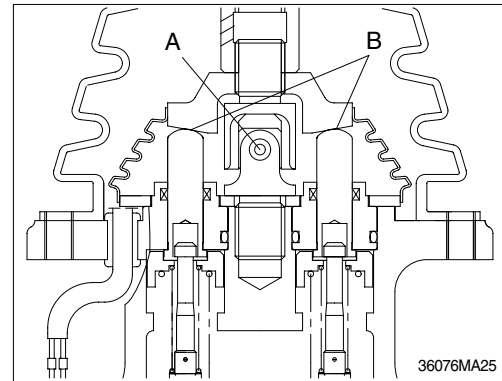

32) ADJUSTMENT OF TRACK TENSION

- ※ It is important to adjust the tension of track properly to extend the lifetime of track and traveling device.
- ※ The wear of pins and bushings on the undercarriage will vary with the working conditions and soil properties.
It is thus necessary to continually inspect the track tension so as to maintain the standard tension on it.

- (1) Raise the chassis with the boom and arm.
 - (2) Measure the distance between bottom of track frame on track center and track of shoe.
- ※ **Remove mud with rotating the track before measuring.**

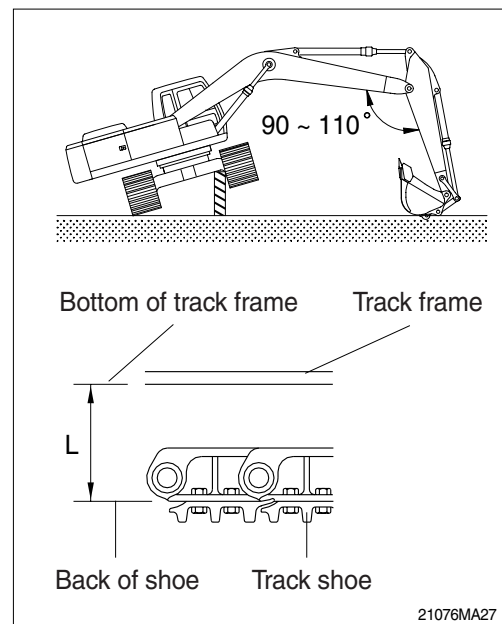

- (3) If the tension is tight, drain the grease in the grease nipple and if the tension is loose, charge the grease.

- ▲ **Personal injury or death can result from grease under pressure.**
- ▲ **When loosening the grease nipple, do not loosen more than one turn as there is a danger of a spring coming out of the nipple because of the high pressure inside.**
- ※ **When the grease is drained, move the track to the forward and backward slightly.**
If the track tension is loose even after the grease is charged to the maximum, change the pins and bushings as there are worn seriously.

Working condition	Length(L)	
	mm	inch
General	360~390mm	14.2~15.4"
Swamp	390~430mm	15.4~16.9"
Sand, Mud, pebbles	About 430mm	About 16.9"

TROUBLESHOOTING GUIDE

1. ENGINE

※ This guide is not intended to cover every conditions, however many of the more common possibilities are listed.

Trouble	Service	Remark
The engine oil pressure lamp lights ON when engine speed is raised after completion of warm up.	<ul style="list-style-type: none"> · Add the oil to the specified level. · Replace the oil filter cartridge. · Check oil leakage from the pipe or the joint. · Replace the monitor. 	
Steam is emitted from the top part of the radiator(The pressure valve). Coolant level warning lamp lights ON.	<ul style="list-style-type: none"> · Supply the coolant and check leakage. · Adjust fan belt tension. · Wash out inside of cooling system. · Clean or repair the radiator fin. · Check the thermostat. · Tighten the radiator cap firmly or replace the packing of it. · Replace the monitor. 	
The engine does not start when the starting motor is turned over.	<ul style="list-style-type: none"> · Add fuel. · Repair where air is leaking into fuel system. · Check the injection pump or the nozzle. · Check the valve clearance. · Check engine compression pressure. 	
Exhaust gas is white or blue.	<ul style="list-style-type: none"> · Adjust to specified oil quantity. · Replace with specified fuel. 	
Exhaust gas occasionally turns black.	<ul style="list-style-type: none"> · Clean or replace the air cleaner element. · Check the nozzle. · Check engine compression pressure. · Clean or replace the turbocharger. 	
Combustion noise occasionally changes to breathing sound.	<ul style="list-style-type: none"> · Check the nozzle. 	
Unusual combustion noise or mechanical noise.	<ul style="list-style-type: none"> · Check with specified fuel. · Check over-heating · Replace the muffler. · Adjust valve clearance. 	

CLICK HERE TO **DOWNLOAD** THE COMPLETE MANUAL

- Thank you very much for reading the preview of the manual.
- You can download the complete manual from: www.heydownloads.com by clicking the link below



- Please note: If there is no response to CLICKING the link, please download this PDF first and then click on it.

CLICK HERE TO **DOWNLOAD** THE COMPLETE MANUAL