

SECTION 1 GENERAL

Group 1 Safety Hints	1-1
Group 2 Specifications	1-10

SECTION 2 STRUCTURE AND FUNCTION

Group 1 Pump Device	2-1
Group 2 Main Control Valve	2-20
Group 3 Swing Device	2-60
Group 4 Travel Device	2-71
Group 5 RCV Lever	2-85
Group 6 RCV Pedal	2-92

SECTION 3 HYDRAULIC SYSTEM

Group 1 Hydraulic Circuit	3-1
Group 2 Main Circuit	3-2
Group 3 Pilot Circuit	3-5
Group 4 Single Operation	3-14
Group 5 Combined Operation	3-24

SECTION 4 ELECTRICAL SYSTEM

Group 1 Component Location	4-1
Group 2 Electric Circuit	4-3
Group 3 Electrical Component Specification	4-23
Group 4 Connectors	4-32

SECTION 5 MECHATRONICS SYSTEM

Group 1 Outline	5-1
Group 2 Mode selection System	5-3
Group 3 Automatic Deceleration System	5-6
Group 4 Power Boost System	5-7
Group 5 Travel Speed Control System	5-8
Group 6 Automatic Warming Up Function	5-9
Group 7 Engine Overheat Prevention Function	5-10
Group 8 Variable Power Control System	5-11

CLICK HERE TO **DOWNLOAD** THE COMPLETE MANUAL

- Thank you very much for reading the preview of the manual.
- You can download the complete manual from: www.heydownloads.com by clicking the link below



- Please note: If there is no response to CLICKING the link, please download this PDF first and then click on it.

CLICK HERE TO **DOWNLOAD** THE COMPLETE MANUAL

TEMPERATURE

Fahrenheit-Centigrade Conversion.

A simple way to convert a fahrenheit temperature reading into a centigrade temperature reading or vice versa is to enter the accompanying table in the center or boldface column of figures.

These figures refer to the temperature in either Fahrenheit or Centigrade degrees.

If it is desired to convert from Fahrenheit to Centigrade degrees, consider the center column as a table of Fahrenheit temperatures and read the corresponding Centigrade temperature in the column at the left.

If it is desired to convert from Centigrade to Fahrenheit degrees, consider the center column as a table of Centigrade values, and read the corresponding Fahrenheit temperature on the right.

°C	°F	°C	°F	°C	°F	°C	°F	°C	°F	°C	°F
-40.4	-40	-40.0	-11.7	11	51.8	7.8	46	114.8	27.2	81	117.8
-37.2	-35	-31.0	-11.1	12	53.6	8.3	47	116.6	27.8	82	179.6
-34.4	-30	-22.0	-10.6	13	55.4	8.9	48	118.4	28.3	83	181.4
-31.7	-25	-13.0	-10.0	14	57.2	9.4	49	120.2	28.9	84	183.2
-28.9	-20	-4.0	-9.4	15	59.0	10.0	50	122.0	29.4	85	185.0
-28.3	-19	-2.2	-8.9	16	60.8	10.6	51	123.8	30.0	86	186.8
-27.8	-18	-0.4	-8.3	17	62.6	11.1	52	125.6	30.6	87	188.6
-27.2	-17	1.4	-7.8	18	64.4	11.7	53	127.4	31.1	88	190.4
-26.7	-16	3.2	-6.7	20	68.0	12.8	55	131.0	32.2	90	194.0
-26.1	-15	5.0	-6.7	20	68.0	12.8	55	131.0	32.2	90	194.0
-25.6	-14	6.8	-6.1	21	69.8	13.3	56	132.8	32.8	91	195.8
-25.0	-13	8.6	-5.6	22	71.6	13.9	57	134.6	33.3	92	197.6
-24.4	-12	10.4	-5.0	23	73.4	14.4	58	136.4	33.9	93	199.4
-23.9	-11	12.2	-4.4	24	75.2	15.0	59	138.2	34.4	94	201.2
-23.3	-10	14.0	-3.9	25	77.0	15.6	60	140.0	35.0	95	203.0
-22.8	-9	15.8	-3.3	26	78.8	16.1	61	141.8	35.6	96	204.8
-22.2	-8	17.6	-2.8	27	80.6	16.7	62	143.6	36.1	97	206.6
-21.7	-7	19.4	-2.2	28	82.4	17.2	63	145.4	36.7	98	208.4
-21.1	-6	21.2	-1.7	29	84.2	17.8	64	147.2	37.2	99	210.2
-20.6	-5	23.0	-1.1	35	95.0	21.1	70	158.0	51.7	125	257.0
-20.0	-4	24.8	-0.6	31	87.8	18.9	66	150.8	40.6	105	221.0
-19.4	-3	26.6	0	32	89.6	19.4	67	152.6	43.3	110	230.0
-18.9	-2	28.4	0.6	33	91.4	20.0	68	154.4	46.1	115	239.0
-18.3	-1	30.2	1.1	34	93.2	20.6	69	156.2	48.9	120	248.0
-17.8	0	32.0	1.7	35	95.0	21.1	70	158.0	51.7	125	257.0
-17.2	1	33.8	2.2	36	96.8	21.7	71	159.8	54.4	130	266.0
-16.7	2	35.6	2.8	37	98.6	22.2	72	161.6	57.2	135	275.0
-16.1	3	37.4	3.3	38	100.4	22.8	73	163.4	60.0	140	284.0
-15.6	4	39.2	3.9	39	102.2	23.3	74	165.2	62.7	145	293.0
-15.0	5	41.0	4.4	40	104.0	23.9	75	167.0	65.6	150	302.0
-14.4	6	42.8	5.0	41	105.8	24.4	76	168.8	68.3	155	311.0
-13.9	7	44.6	5.6	42	107.6	25.0	77	170.6	71.1	160	320.0
-13.3	8	46.4	6.1	43	109.4	25.6	78	172.4	73.9	165	329.0
-12.8	9	48.2	6.7	44	111.2	26.1	79	174.2	76.7	170	338.0
-12.2	10	50.0	7.2	45	113.0	26.7	80	176.0	79.4	172	347.0

DISPOSE OF FLUIDS PROPERLY

Improperly disposing of fluids can harm the environment and ecology. Before draining any fluids, find out the proper way to dispose of waste from your local environmental agency.

Use proper containers when draining fluids. Do not use food or beverage containers that may mislead someone into drinking from them.

DO NOT pour oil into the ground, down a drain, or into a stream, pond, or lake. Observe relevant environmental protection regulations when disposing of oil, fuel, coolant, brake fluid, filters, batteries, and other harmful waste.

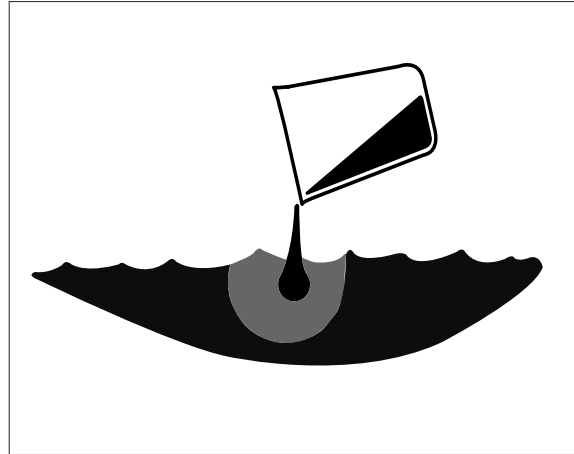

REPLACE SAFETY SIGNS

Replace missing or damaged safety signs. See the machine operator's manual for correct safety sign placement.

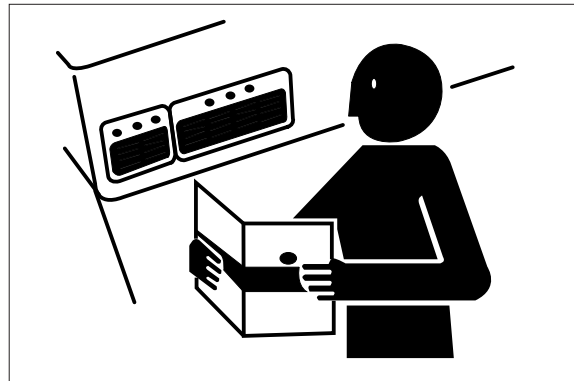

LIVE WITH SAFETY

Before returning machine to customer, make sure machine is functioning properly, especially the safety systems. Install all guards and shields.

9) HX520 L

· 7.06 m (23' 2") BOOM, 2.40 m (7' 10") ARM

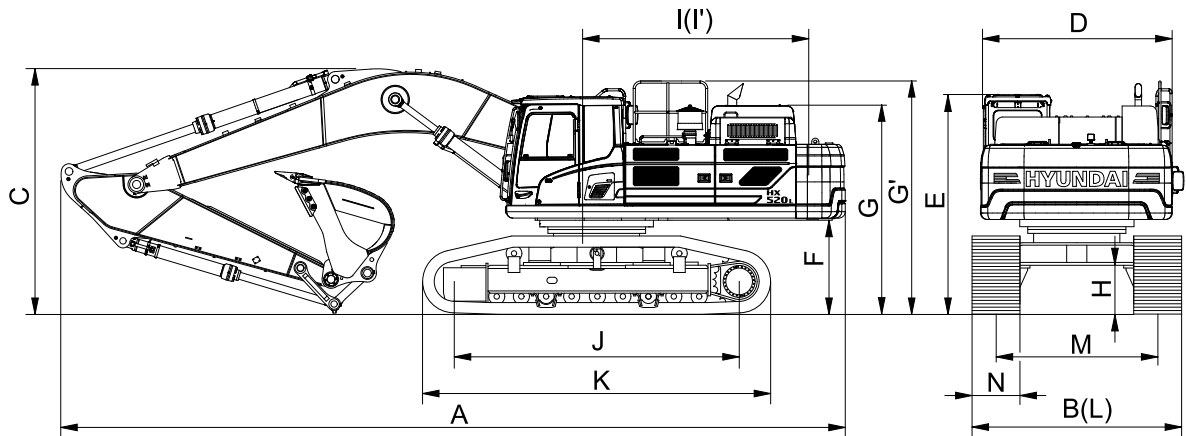

480F2SP03

Description	Unit	Specification
Operating weight	kg (lb)	52160 (114990)
Bucket capacity (SAE heaped), standard	m ³ (yd ³)	2.20 (2.88)
Overall length	A	12510 (41' 1")
Overall width, with 600 mm shoe (transport position / working position)	B	2980/3540 (9' 10"/11' 7")
Overall height	C	4070 (13' 4")
Superstructure width	D	2980 (9' 9")
Overall height of cab	E	3340 (10' 11")
Ground clearance of counterweight	F	1445 (4' 9")
Engine cover height	G	3030 (9' 11")
Overall height of handrail	G'	3595 (11' 8")
Minimum ground clearance	H	770 (2' 6")
Rear-end distance	I	3885 (12' 9")
Rear-end swing radius	I'	3940 (12' 11")
Distance between tumblers	J	4470 (14' 8")
Undercarriage length	K	5405 (17' 7")
Undercarriage width (transport position / working position)	L	2990/3540 (9' 10"/11' 7")
Track gauge (transport position / working position)	M	2380/2940 (7' 10"/9' 8")
Track shoe width, standard	N	600 (24")
Travel speed (low/high)	km/hr (mph)	3.3/5.3 (2.1/3.3)
Swing speed	rpm	8.6
Gradeability	Degree (%)	35 (70)
Ground pressure (600 mm shoe)	kgf/cm ² (psi)	0.91 (12.94)
Max traction force	kg (lb)	34100 (75180)

5) HX520 L

· 6.55 m (21' 6") BOOM

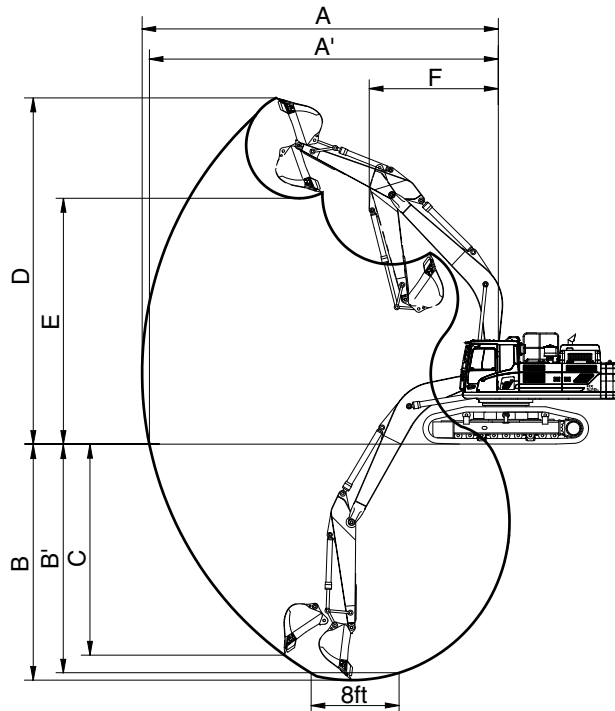













480F2SP05

Description		2.40 m (7' 10") Arm	2.90 m (9' 6") Arm
Max digging reach	A	10690 mm (35' 1")	11130 mm (36' 6")
Max digging reach on ground	A'	10430 mm (34' 3")	10870 mm (35' 8")
Max digging depth	B	6240 mm (20' 6")	6740 mm (22' 1")
Max digging depth (8ft level)	B'	6060 mm (19' 11")	6580 mm (21' 7")
Max vertical wall digging depth	C	4370 mm (14' 4")	5420 mm (17' 9")
Max digging height	D	10390 mm (34' 1")	10660 mm (35' 0")
Max dumping height	E	7040 mm (23' 1")	7210 mm (23' 8")
Min swing radius	F	4870 mm (16' 0")	4540 mm (14' 11")
Bucket digging force	SAE	241.2 [263.2] kN	241.2 [263.2] kN
		24600 [26840] kgf	24600 [26840] kgf
		54230 [59170] lbf	54230 [59170] lbf
	ISO	280.5 [306.0] kN	280.5 [306.0] kN
		28600 [31200] kgf	28600 [31200] kgf
		63050 [68780] lbf	63050 [68780] lbf
Arm crowd force	SAE	278.5 [303.8] kN	225.6 [246.1] kN
		28400 [30980] kgf	23000 [25090] kgf
		62610 [68300] lbf	50710 [55310] lbf
	ISO	291.3 [317.7] kN	235.4 [256.7] kN
		29700 [32400] kgf	24000 [26180] kgf
		65480 [71430] lbf	52910 [57720] lbf

[] : Power boost













(4) 7.06 m (23' 2") boom, 2.90 m (9' 6") arm equipped with 2.20 m³ (SAE heaped) bucket and 600 mm (24") triple grouser shoe and 10,200 kg (22,490 lb) counterweight.

·  : Rating over-front ·  : Rating over-side or 360 degree

Load point height		Load radius										At max. reach				
		3.0 m (9.8 ft)		4.5 m (14.7 ft)		6.0 m (19.6 ft)		7.5 m (24.5 ft)		9.0 m (29.4 ft)		Capacity		Reach		
														m (ft)		
7.5 m (24.5 ft)	kg							*11360	*11360					*9210	7190	10.11
	lb							*25050	*25050					*20310	15860	33.03
6.0 m (19.6 ft)	kg							*12120	11520					*9220	6250	10.76
	lb							*26730	25400					*20340	13770	35.15
4.5 m (14.7 ft)	kg			*19010	*19010	*15110	*15110	*13300	11010	*12330	8060	9050	5720	11.13		
	lb			*41900	*41900	*33310	*33310	*29320	24270	*27180	17770	19940	12600	36.37		
3.0 m (9.8 ft)	kg			*23620	23090	*17420	14840	*14570	10470	12350	7770	8730	5470	11.26		
	lb			*52060	50900	*38400	32710	*32120	23090	27230	17130	19250	12050	36.80		
1.5 m (4.9 ft)	kg			*21570	*21570	*19080	14100	*15610	10020	12070	7510	8770	5460	11.16		
	lb			*47560	*47560	*42070	31080	*34410	22090	26600	16560	19320	12040	36.45		
Ground Line	kg			*25090	21760	*19800	13690	15860	9730	11880	7340	9180	5720	10.81		
	lb			*55310	47970	*43660	30190	34960	21440	26180	16170	20230	12610	35.32		
-1.5 m (-4.9 ft)	kg	*20350	*20350	*24810	21780	*19640	13570	15730	9610			10110	6330	10.19		
	lb	*44860	*44860	*54690	48020	*43300	29910	34670	21180			22280	13950	33.30		
-3.0 m (-9.8 ft)	kg	*28610	*28610	*23130	22020	*18630	13670	*15310	9690			*11360	7540	9.23		
	lb	*63060	*63060	*50990	48550	*41080	30140	*33750	21360			*25040	16620	30.17		
-4.5 m (-14.7 ft)	kg			*20370	*20370	*16510	14020					*10730	10170	7.79		
	lb			*44910	*44910	*36390	30910					*23650	22430	25.43		

(5) 7.06 m (23' 2") boom, 3.38 m (11' 1") arm equipped with 2.20 m³ (SAE heaped) bucket and 600 mm (24") triple grouser shoe and 10,200 kg (22,490 lb) counterweight.

·  : Rating over-front ·  : Rating over-side or 360 degree

Load point height		Load radius										At max. reach		
		3.0 m (9.8 ft)		4.5 m (14.7 ft)		6.0 m (19.6 ft)		7.5 m (24.5 ft)		9.0 m (29.4 ft)		Capacity		Reach
														m (ft)
6.0 m (19.6 ft)	kg							*11640	*11640	*11410	8380	*7750	5820	11.18
	lb							*25650	*25650	*25160	18480	*17080	12840	36.53
4.5 m (14.7 ft)	kg			*17410	*17410	*14350	*14350	*12860	11130	*12030	8110	*7860	5340	11.54
	lb			*38390	*38390	*31640	*31640	*28360	24540	*26530	17890	*17330	11780	37.70
3.0 m (9.8 ft)	kg			*22210	*22210	*16770	15090	*14210	10580	12390	7800	*8060	5120	11.67
	lb			*48960	*48960	*36960	33280	*31330	23320	27320	17200	*17760	11280	38.11
1.5 m (4.9 ft)	kg			*25070	22400	*18660	14280	*15370	10100	12080	7520	8240	5100	11.57
	lb			*55270	49380	*41150	31490	*33880	22260	26630	16570	18160	11250	37.78
Ground Line	kg			*25800	21880	*19670	13790	15900	9760	11850	7310	8590	5320	11.23
	lb			*56880	48230	*43370	30400	35040	21510	26120	16110	18930	11730	36.69
-1.5 m (-4.9 ft)	kg	*19680	*19680	*25300	21780	*19800	13580	15700	9580	11750	7210	9370	5830	10.64
	lb	*43390	*43390	*55780	48010	*43640	29940	34620	21130	25890	15900	20660	12860	34.77
-3.0 m (-9.8 ft)	kg	*25950	*25950	*23920	21930	*19080	13600	15710	9590			*10510	6840	9.74
	lb	*57200	*57200	*52740	48350	*42069	29990	34630	21140			*23180	15080	31.82
-4.5 m (-14.7 ft)	kg	*27870	*27870	*21540	*21540	*17390	13850					*10990	8910	8.39
	lb	*61430	*61430	*47480	*47480	*38330	30530					*24230	19640	27.41

8. SPECIFICATIONS FOR MAJOR COMPONENTS

1) ENGINE

Item	Specification
Model	Scania DC13
Type	4-cycle turbocharged charger air cooled diesel engine
Cooling method	Water cooling
Number of cylinders and arrangement	6 cylinders, in-line
Firing order	1-5-3-6-2-4
Combustion chamber type	Direct injection type
Cylinder bore × stroke	130 × 160 mm (5.12" × 6.3")
Piston displacement	12700 cc (775 cu in)
Compression ratio	17.5 : 1
Rated net horse power (SAE J1349)	424 Hp at 1900 rpm (316 kW at 1900 rpm)
Rated gross horse power (SAE J1995)	444 Hp at 1900 rpm (331 kW at 1900 rpm)
Maximum torque	232 kgf · m (1678 lbf · ft) at 1300 rpm
Engine oil quantity	38 ℓ (10 U.S. gal)
Dry weight	1075 kg (2370 lb)
Low idling speed	800 ± 50 rpm
High idling speed	1900 + 50 rpm
Rated fuel consumption	152.8 g/Hp · hr at 1900 rpm
Starting motor	24V-5.5kW
Alternator	24V-100A
Battery	2 × 12V × 200Ah

2) MAIN PUMP

Item	Specification
Type	Variable displacement tandem axis piston pumps
Capacity	2 × 200 cc/rev
Maximum pressure	330 kgf/cm ² (4690 psi) [360 kgf/cm ² (5120 psi)]
Rated oil flow	2 × 380 ℓ/min (100.4 U.S. gpm / 83.6 U.K. gpm)
Rated speed	1750 rpm

[] : Power boost

3) REAR REGULATOR (1/2)

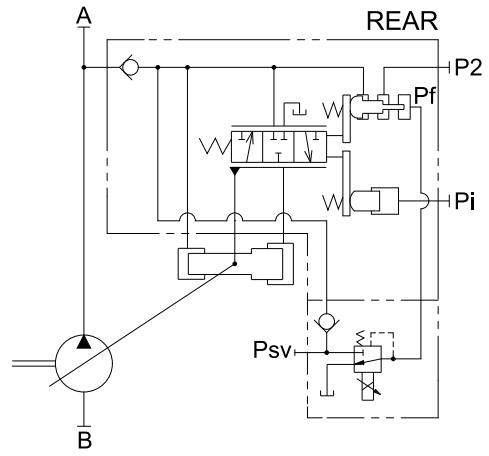
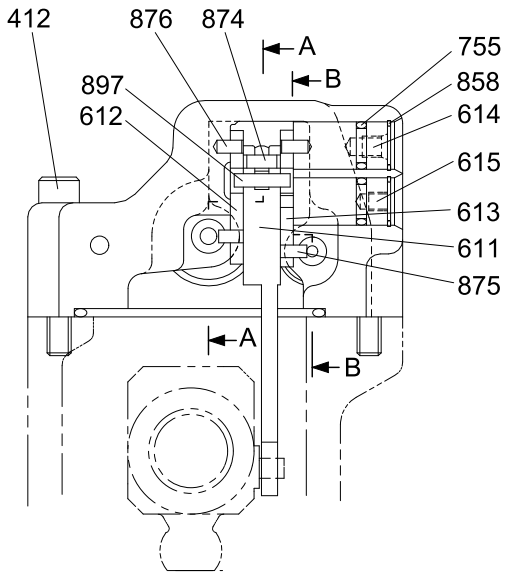

Hydraulic circuit

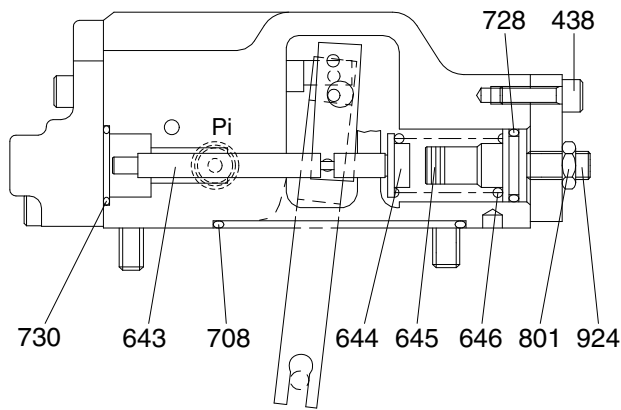

SECTION B-B

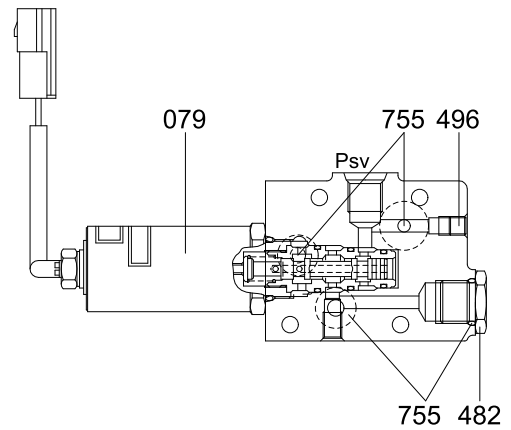

SECTION D-D

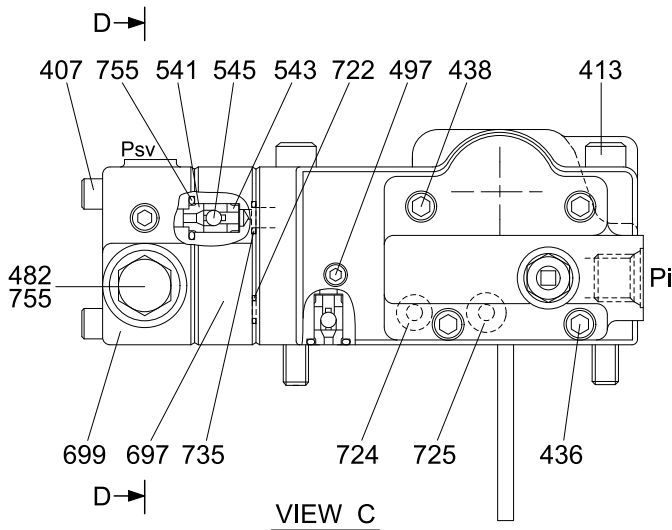

VIEW C

Port	Port name	Port size
Pi	Pilot port	PF 1/4 - 15
Psv	Servo assist port	PF 1/4 - 15
P2	Companion delivery port	-
Pf	Powershift port	-

480F2RG03

(2) Total horsepower control

The regulator decreases the pump tilting angle (delivery flow) automatically to limit the input torque within a certain value with a rise in the delivery pressure P1 of the self pump and the delivery pressure P2 of the companion pump.

(The input horsepower is constant when the speed is constant.)

Since the regulator is of the simultaneous total horsepower type that operates by the sum of load pressures of the two pumps in the tandem double-pump system, the prime mover is automatically prevented from being overloaded, irrespective of the load condition of the two pumps, when horsepower control is under way.

Since this regulator is of the simultaneous total horsepower type, it controls the tilting angles (displacement volumes) of the two pumps to the same value as represented by the following equation :

$$\begin{aligned} T_{in} &= P1 \times q / 2 \pi + P2 \times q / 2 \pi \\ &= (P1+P2) \times q / 2 \pi \end{aligned}$$

The horsepower control function is the same as the flow control function and is summarized in the following. (For detailed behaviors of respective parts, refer to the section of flow control).

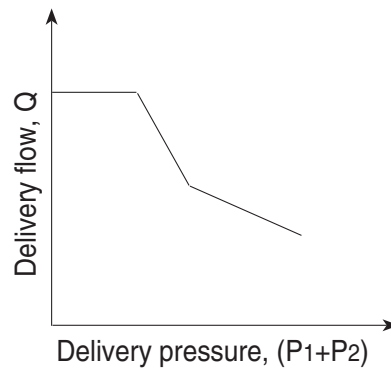

2. HYDRAULIC CIRCUIT

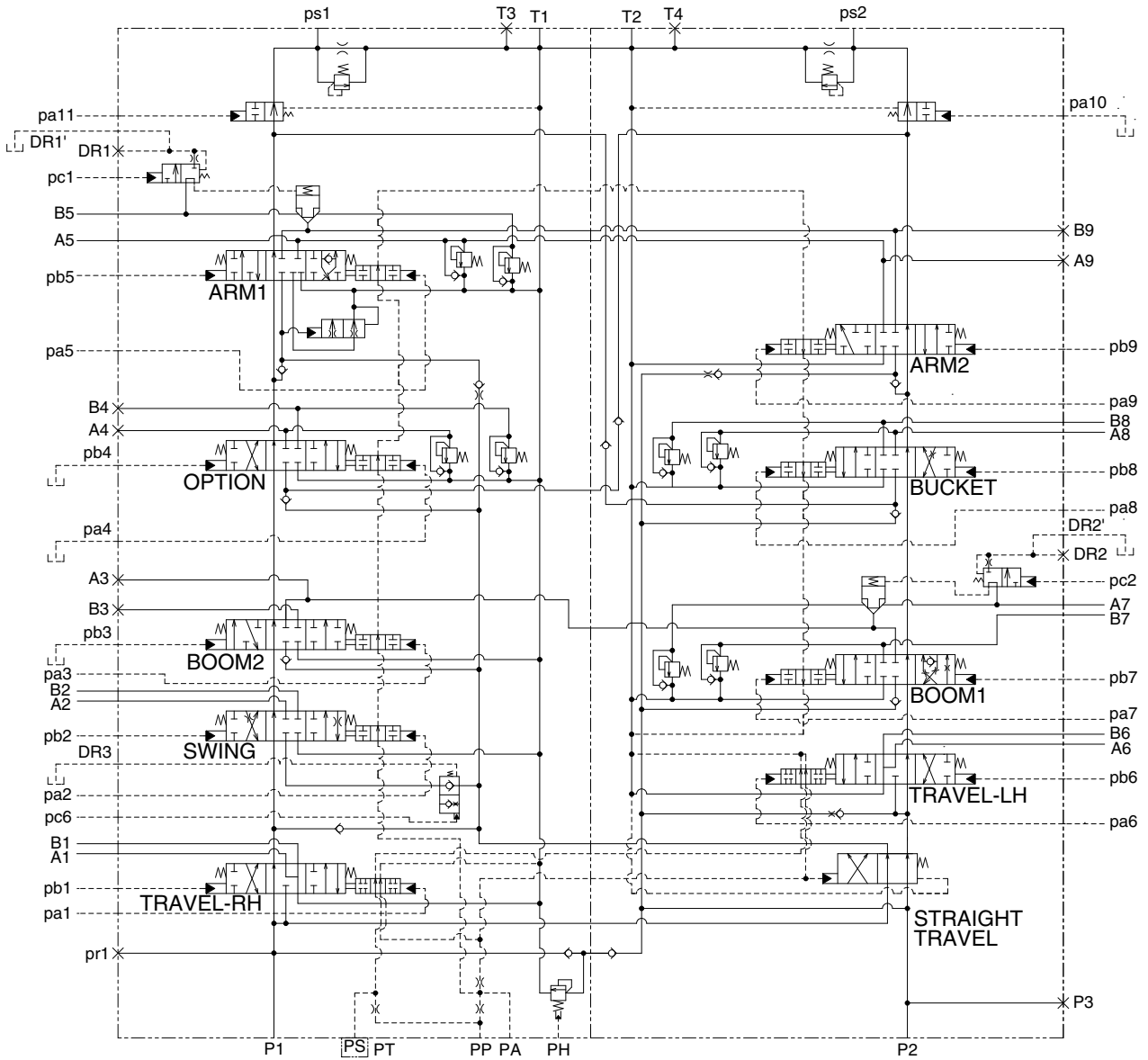

480F2MC05

(2) Arm in (flow summation)

When the arm 1 spool is pushed to the left by the pilot pressure of port Pa5, the oil discharged from pump P1 flow into the port A5 via neutral passage (L1), the load check valve (S5-1) and passage (S5-2).

When the arm 2 spool is pushed to the left by the pilot pressure of port Pa9, the oil discharged from pump P2 flows together into the port A5 via neutral passage (R1), the load check valve (S9-1) and passage (S9-2).

At the same time, as the port pc1 is pressurizing and the spool (AD3) of anti-drift valve is pushed down, the pressure of spring chamber (AD5) is released and the poppet (AD1) is opened and then the oil returned from port B5 flows into the tank passage (Ta) through the passage (S5-4) inside arm 1 spool to open and is connected to the passage (S5-2) and flows together into the port A5, the cylinder speed is raised and also prevents the cavitation of bottom side.

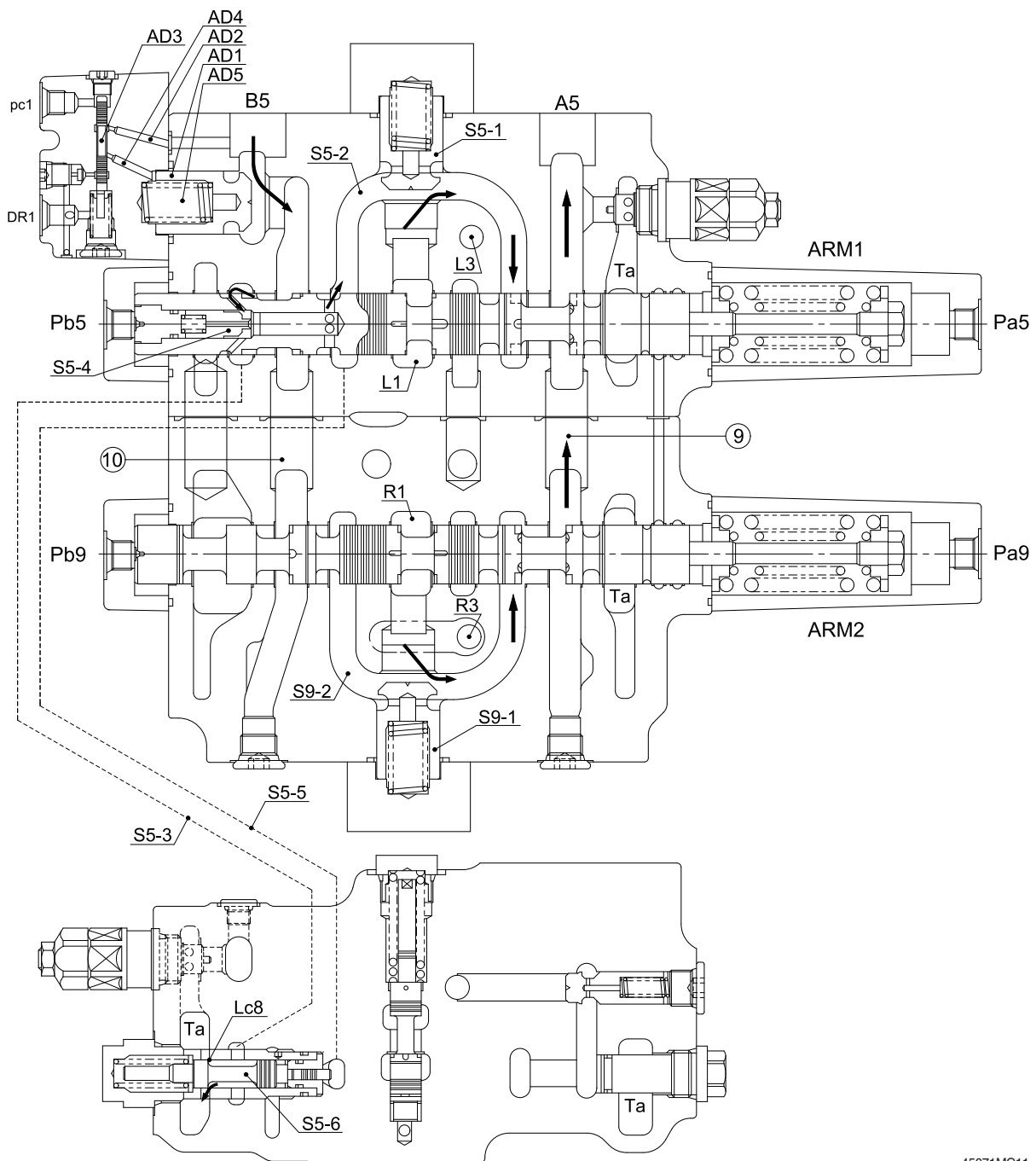

(4) The oil flow from the high pressure passage (HP) to the poppet (D) behind is only around poppet and orifice (F); then the high pressure passage (HP) is higher than the poppet (D) behind pressure.

Thus the poppet (D) is pushed open and the oil directly flows into low pressure passage (LP).

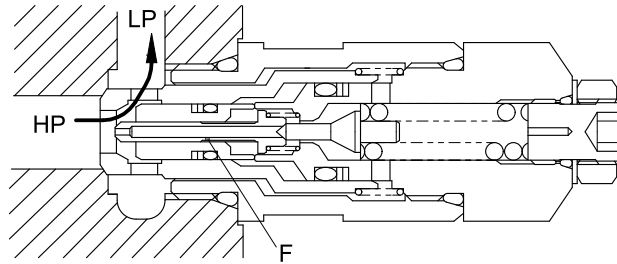

45071MC18-3

(5) Make up operation

This relief valve is built-in the cylinder port (HP) and the low pressure passage (LP), and the pressure oil fills up chamber (G) inside via hole of piston (C).

Thus the sleeve (K) and the main poppet (D) are securely seated by difference area of A and B.

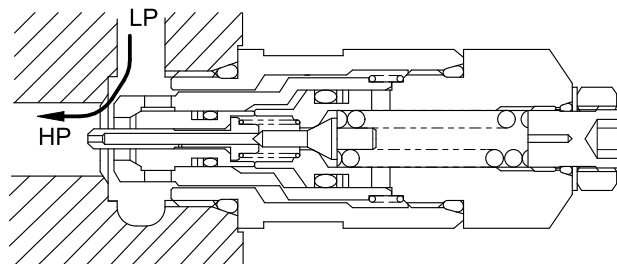

45071MC18-4

4) BRAKE SYSTEM

(1) Control valve swing brake system

This is the brake system to stop the swing motion of the excavator during operation.

In this system, the hydraulic circuit is throttled by the swing control valve, and the resistance created by this throttling works as a brake force to slow down the swing motion.

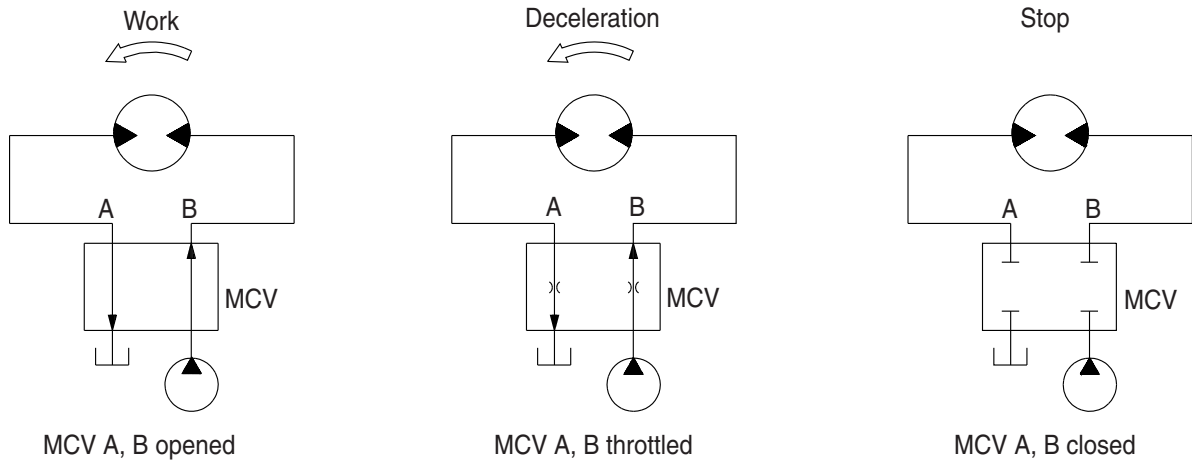

2-48(1)

(2) Mechanical swing parking brake system

This is function as a parking brake only when all of the RCV lever (except travel pedal) are not operated.

① Brake assembly

Circumferential rotation of separate plate (16) is constrained by the groove located at housing (1). When housing is pressed down by brake spring (20) through friction plate (15), separate plate (16) and brake piston (17), friction force occurs there.

Cylinder block (10) is constrained by this friction force and brake acts, while brake releases when hydraulic force exceeds spring force.

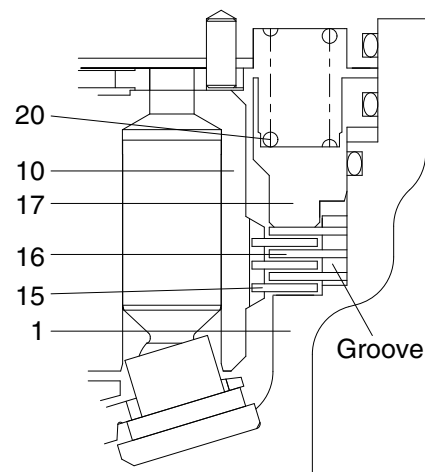

21092SM15

1	Housing	16	Separate plate
10	Cylinder block	17	Brake piston
15	Friction plate	20	Spring

(2) Operation

Two pieces of overload valves are located at cross-over position in the counterbalance circuit of brake valve and have the following functions:

- ① When hydraulic motor starts, keep the driving pressure below predetermined value and while accelerating, bypasses surplus oil to return line.
- ② When stopping the motor, keep the brake pressure, that develops on the outlet side of motor, under the predetermined value to stop the inertial force.
- ③ To accelerate sharply while starting, and to mitigate the braking shock while stopping. For these purposes, the developed pressure is kept comparatively low for a short period, then keep the line pressure as normal value. While the pressure is low, meshing of reduction gears, crawler and sprocket etc. can be smoothly done and the shock are absorbed.

When starting, "A" port pressure of overload valve increases, this pressure is applied to the effective diameter of poppet (45-9) which seats on the poppet seat (45-10) and, at the same time, is delivered, via small hole, to the spring seat (45-5) located inside the sleeve (45-6) and the seat bore pressure increases up to "A" port pressure. The poppet (45-9) opposes to spring (45-4) by the force of the pressure exerted on the area difference between poppet seat's effective diameter and spring seat bore and keep the predetermined pressure.

When hydraulically braking, the piston (45-7) is at the left position by the driving pressure, and when "A" port pressure increases, the pressure is applied also to the piston (45-7) through the small hole in the poppet (45-9) and piston (45-7) moves rightward until it touches the stopper in rear cover. In this while, the poppet (45-9) maintains "A" port pressure at comparatively low against the spring (45-4) force and exhaust oil to "B" port side. After the piston reached to the plug, the valve acts the same as at starting.

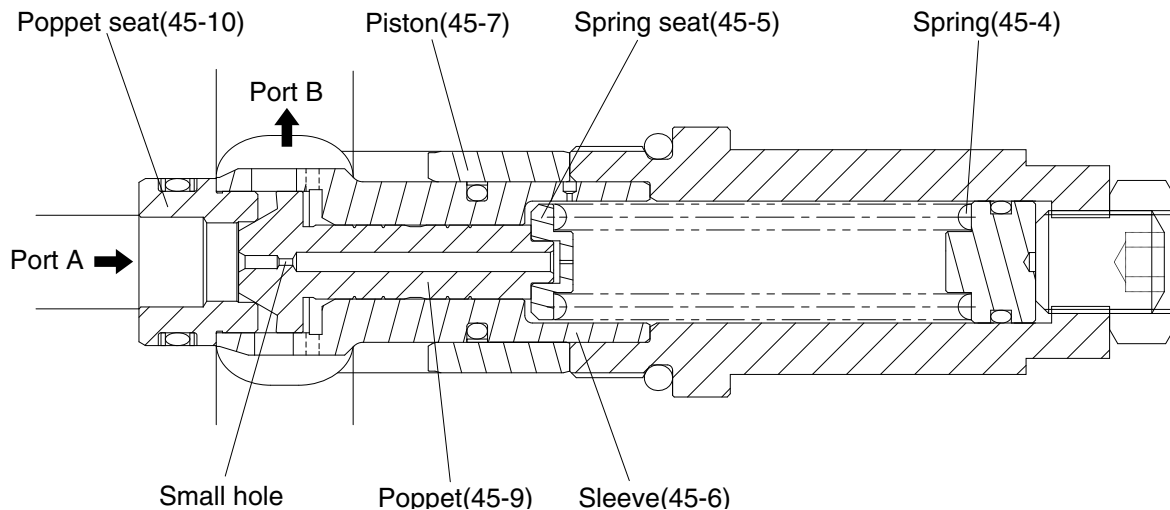

480F2TM08

2. FUNCTIONS

1) FUNDAMENTAL FUNCTIONS

The pilot valve is a valve that controls the spool stroke, direction, etc of a main control valve. This function is carried out by providing the spring at one end of the main control valve spool and applying the output pressure (secondary pressure) of the pilot valve to the other end.

For this function to be carried out satisfactorily, the pilot valve is composed of the following elements.

- (1) Inlet port (P) where oil is supplied from hydraulic pump.
- (2) Output ports (1, 2, 3 & 4) to apply pressure supplied from inlet port to ends of control valve spools.
- (3) Tank port (T) necessary to control the above output pressure.
- (4) Spool to connect output port to inlet port or tank port.
- (5) Mechanical means to control output pressure, including springs that work on the above spools.

2) FUNCTIONS OF MAJOR SECTIONS

Item numbers are based on the type L1.

The functions of the spool (3) are to receive the supply oil pressure from the hydraulic pump at its port P, and to change over oil paths to determine whether the pressure oil of port P is led to output ports 1, 2, 3 & 4 or the output port pressure oil to tank port T.

The spring (5) works on this spool to determine the output pressure.

The change the deflection of this spring, the push rod (9) is inserted and can slide in the plug (8).

For the purpose of changing the displacement of the push rod through the swash plate (16) and adjusting nut (17) are provided the handle assy (20) that can be tilted in any direction around the fulcrum of the universal joint (15) center.

The spring (7) works on the case (1) and spring seat (6) and tries to return the push rod (9) to the zero-displacement position irrespective of the output pressure, securing its resetting to the center position.

This also has the effect of a reaction spring to give appropriate control feeling to the operator.

SECTION 3 HYDRAULIC SYSTEM

Group 1 Hydraulic Circuit	3-1
Group 2 Main Circuit	3-2
Group 3 Pilot Circuit	3-5
Group 4 Single Operation	3-14
Group 5 Combined Operation	3-24

4. TRAVEL SPEED CONTROL SYSTEM

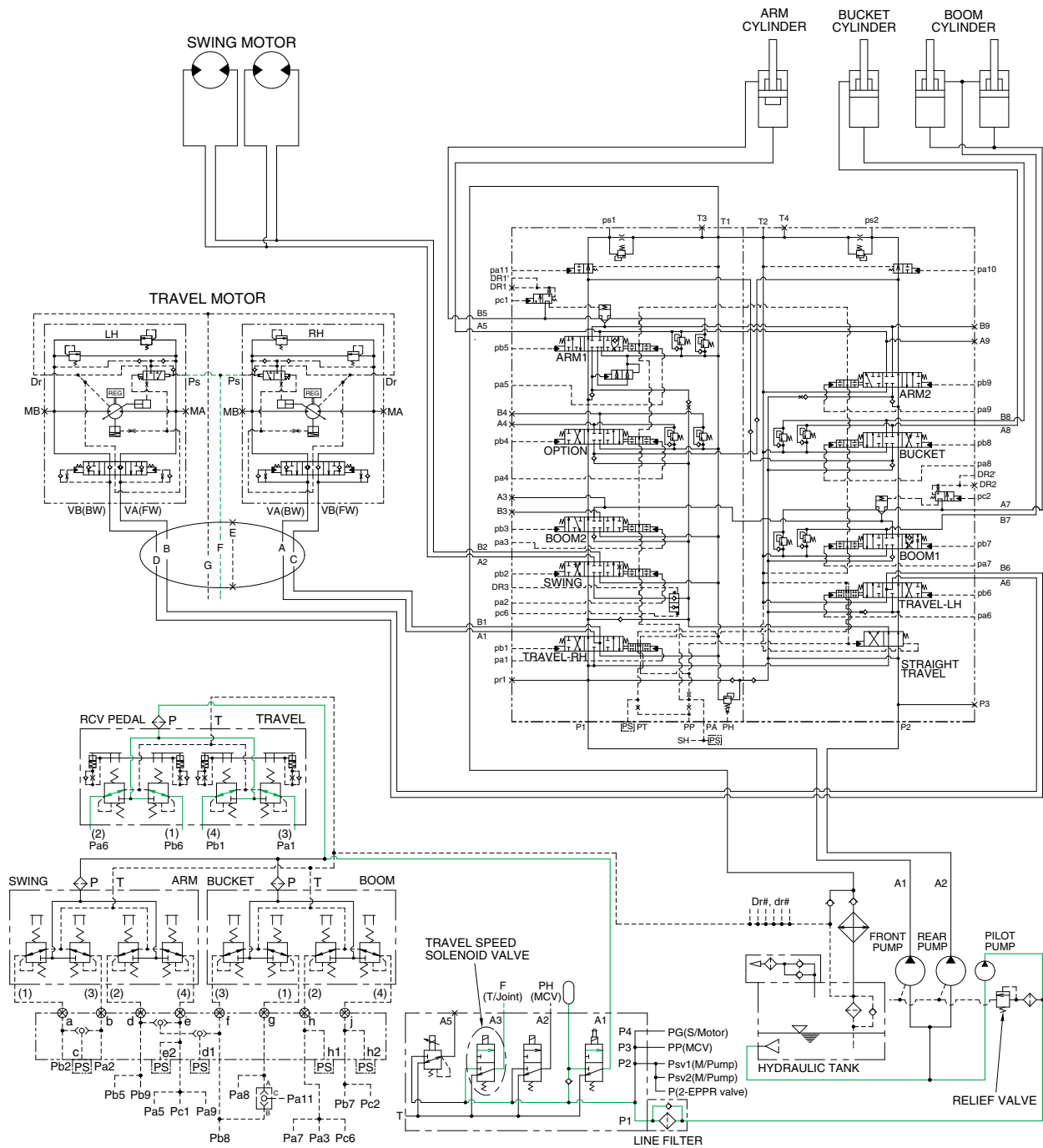

480F3HC05

When the travel speed solenoid valve was placed in the Hi position, the pressure oil from pilot pump through line filter flows to port **Ps** of travel speed change over valve, and the control piston is pushed up, thus minimizing the displacement.

When the travel speed solenoid valve was placed in the Lo position, the oil of **Ps** port return to the tank and the control piston is returned, thus maximizing the displacement.

7. SWING OPERATION

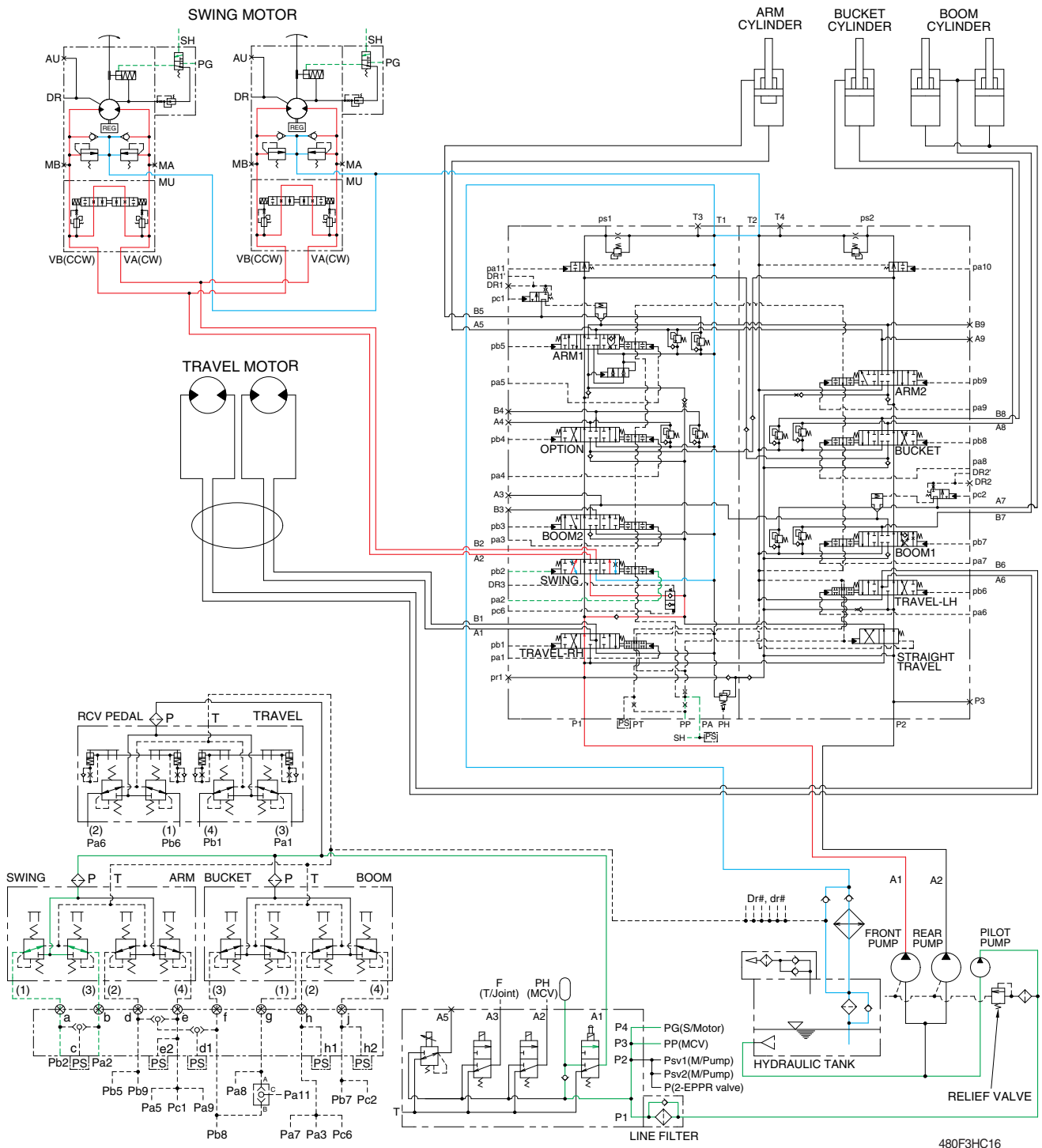

When the LH control lever is pushed left or right, the swing spool in the main control valve is moved to the left or right swing position by the pilot oil pressure from the remote control valve.

The oil from the A1 pump flows into the main control valve and then goes to the swing motor.

At the same time, the return oil from the swing motor returns to the hydraulic oil tank through the swing spool in the main control valve.

When this happens, the upper structure swings to the left or right.

The swing parking brake, make up valve and the motor brake valve are provided in the swing motor. The cavitation which will happen to the swing motor is also prevented by the make up valve in the swing motor itself.

7. COMBINED ARM AND TRAVEL OPERATION

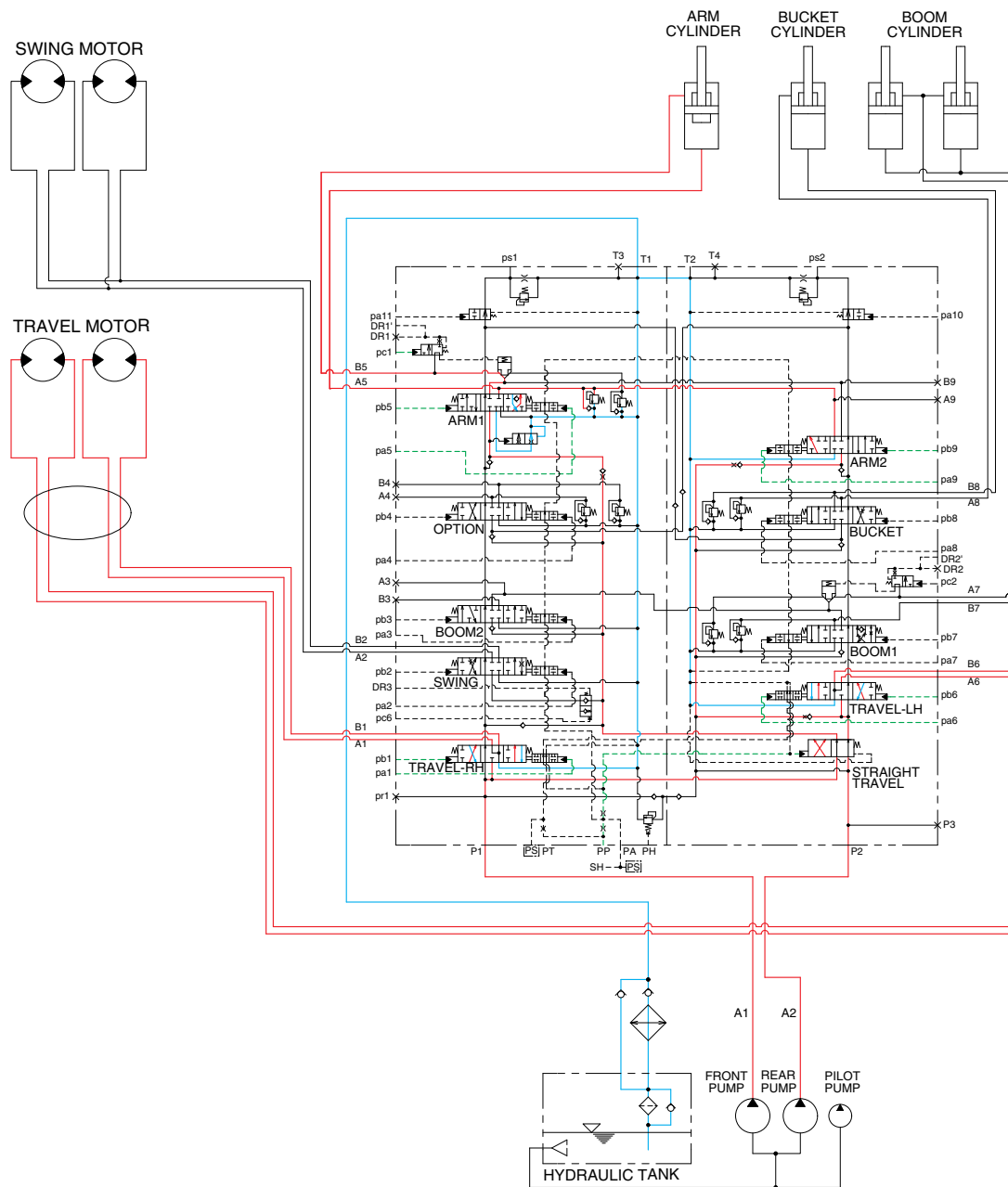

480F3HC26

When the arm and travel functions are operated, simultaneously the arm spools and travel spools in the main control valve are moved to the functional position by the pilot oil pressure from the remote control valve and the straight travel spool is pushed to the right by the oil pressure from pilot pump. The oil from the A1 pump flows into the travel motors through the RH travel spool of the left control valve and the LH travel spool of the right control valve via the straight travel spool. The oil from the A2 pump flows into the arm cylinders through the arm 1 spool and arm 2 spool via the parallel and confluence oil passage. The arm is operated and the machine travels straight.

3. CHARGING CIRCUIT

OLD VERSION

When the starter is activated and the engine is started, the operator releases the key switch to the ON position.

Charging current generated by operating alternator flows into the battery through the battery relay [CR-1].

The current also flows from alternator to each electrical component and controller through the fuse box.

1) OPERATING FLOW

(1) Warning flow

- Alternator "I" terminal → ECM control
- Cluster charging warning lamp (Via CAN interface)

(2) Charging flow

- Alternator "B+" terminal → Battery relay(M8)
 - Battery(+) terminal
 - Circuit breaker [CN-60] → Master switch [CS-74A]
 - Fuse box

2) CHECK POINT

Engine	Start switch	Check point	Voltage
Run	ON	① - GND (battery voltage) ② - GND (battery relay) ③ - GND (alternator B ⁺ terminal) ④ - GND (alternator I terminal)	20~25V

※ GND : Ground

BEACON LAMP AND CAB LIGHT CIRCUIT

CURRENT VERSION

1) OPERATING FLOW

Fuse box (No.30) → Beacon lamp relay [CR-36 (2, 3)]

Fuse box (No.19) → Cab light relay [CR-9 (30, 86)]

Fuse box (No.14) → Relay drive unit [CN-376 (1)]

(1) Beacon lamp switch ON

Beacon lamp switch ON [CN-376 (15)] → Beacon lamp relay [CR-36 (1)→ (5)]

→ I/conn [CN-5 (50)] → I/conn [CN-10 (10)] → Beacon lamp ON [CL-7]

(2) Cab light switch ON

Cab light switch ON [CN-376 (5)] → Cab lamp relay [CR-9 (85) → (87)]

→ I/conn [CN-5 (34, 38)] → I/conn [CN-10 (11)] → Cab light ON [CL-8 (2)]

→ I/conn [CN-10 (12)] → Cab light ON [CL-9 (2), CL-10 (2)]

2) CHECK POINT

Engine	Start switch	Check point	Voltage
STOP	ON	① - GND (fuse box) ② - GND (beacon lamp relay) ③ - GND (switch power output) ④ - GND (beacon lamp) ⑤ - GND (fuse box) ⑥ - GND (cabin light relay) ⑦ - GND (switch power output) ⑧ - GND (cab light) ⑨ - GND (fuse box) ⑩ - GND (relay drive unit power input)	20~25V

※ GND : Ground

ELECTRIC CIRCUIT FOR HYDRAULIC

OLD VERSION

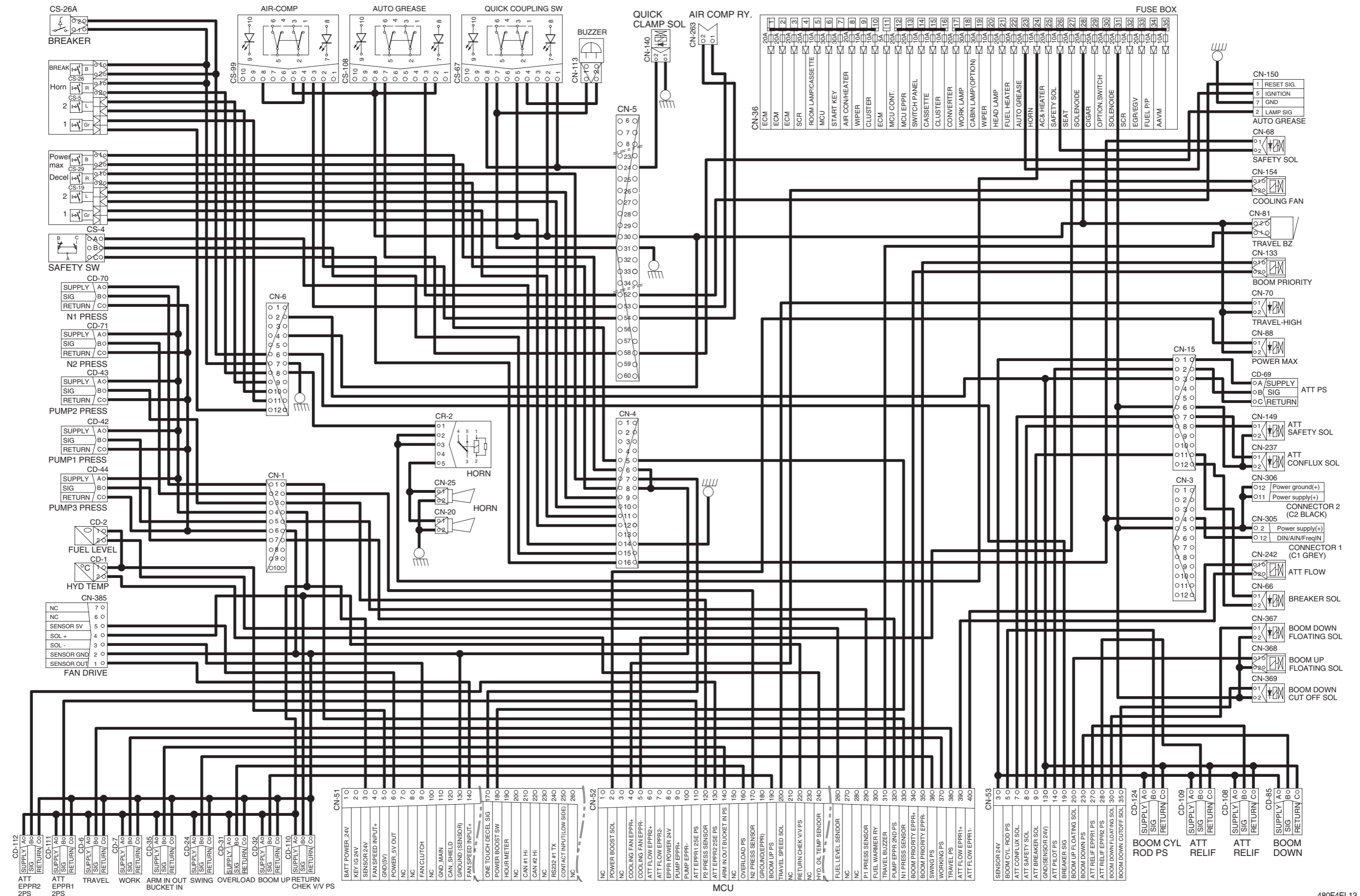

GROUP 4 CONNECTORS

1. CONNECTOR DESTINATION

Connector number	Type	No. of pin	Destination	Connector part No.	
				Female	Male
CN-1	AMP	10	I/conn (Frame harness-Pump PS harness)	S816-010002	S816-110002
CN-2	DEUTSCH	4	I/conn (Frame harness-Engine harness)	DT06-4S-EP06	DT06-4P-E005
CN-3	DEUTSCH	6	I/conn (Frame harness-Engine harness)	DT06-4S-EP06	DT06-4P-E005
CN-4	AMP	16	I/conn (Console harness LH-Frame harness)	368047-1	368050-1
CN-5	DEUTSCH	60	I/conn (Side harness RH-Frame harness)	DRB16-60SAE-L018	DRB12-60P-L018
CN-6	AMP	16	I/conn (Console harness RH-Frame harness)	368047-1	368050-1
CN-7	AMP	15	I/conn (Console harness RH-Frame harness)	2-85262-1	368301-1
CN-8	AMP	10	I/conn (Console harness RH-Frame harness)	S816-010002	S816-110002
CN-9	DEUTSCH	12	I/conn (AAVM harness-Frame harness)	DT06-12SA-P021	DT04-12PA-P021
CN-10	DEUTSCH	12	I/conn (Cab harness-Side harness RH)	DT06-12S-EP06	DT04-12PA-P021
CN-11	DEUTSCH	8	I/conn (Frame harness-Aircon harness)	DT06-8S-EP06	-
CN-12	DEUTSCH	2	I/conn (Frame harness-Boom wire harness)	DT06-2S-EP06	DT04-2P-E005
CN-15	AMP	12	I/conn (Frame harness-Breaker sol)	S816-012002	S816-112002
CN-16	DEUTSCH	8	I/conn (Frame harness-Engine harness)	DT06-8S-EP06	-
CN-17	AMP	8	I/conn (Wiper harness-Side harness RH)	S816-008002	S816-108002
CN-20	DEUTSCH	2	Horn	DT06-2S-EP06	DT04-2P-E005
CN-21	AMP	6	Wiper motor	S810-006202	-
CN-22	KET	2	Washer pump	MG640605	-
CN-23	KET	2	Speaker-LH	MG610070	-
CN-24	KET	2	Speaker-RH	MG610070	-
CN-25	DEUTSCH	2	Horn	DT06-2S-EP06	-
CN-27A	KUM	16	Radio & USB player	PK145-16017	-
CN-27B	AMP	8	Radio & USB player	-	174984-2
CN-28	DEUTSCH	2	Aircon compressor	-	DT04-2P-E005
CN-29	KET	2	Receiver dryer	MG640795	-
CN-36	-	-	Fuse & relay box	21Q7-10910	-
CN-45	RING-TERM	-	Starter motor B+	S820-108000	-
CN-48	KET	1	Hour meter	2-520193-2	-
CN-51	DEUTSCH	40	MCU	DRC26-40SA	-
CN-52	DEUTSCH	40	MCU	DRC26-40SB	-
CN-53	DEUTSCH	40	MCU	DRC26-40SC	-
CN-56A	AMP	12	Cluster	-	174663-2
CN-56B	AMP	8	Cluster	-	174984-2
CN-60	YAZAKI	4	Circuit breaker	-	7222-4220-30
CN-61	DEUTSCH	2	Fuel filler pump	DT06-2S-EP06	DT04-2P-E005

4) CN TYPE CONNECTOR

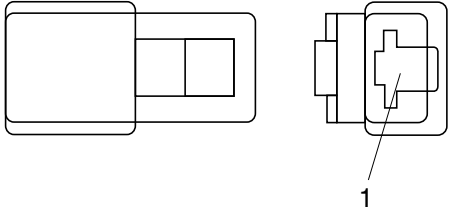
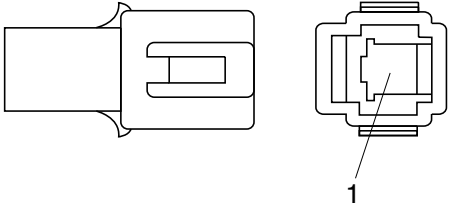
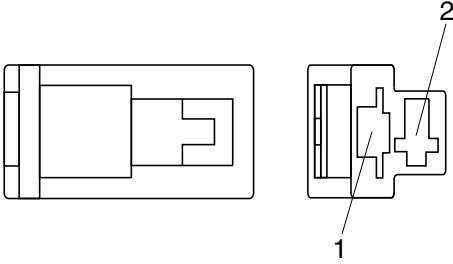
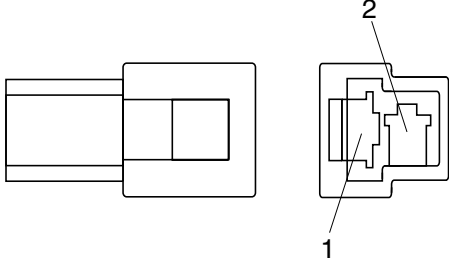
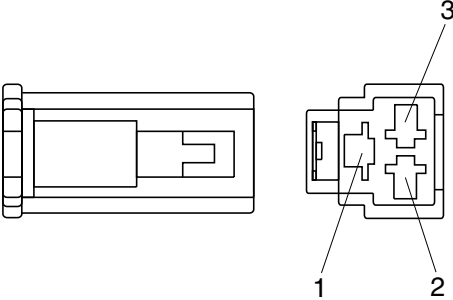
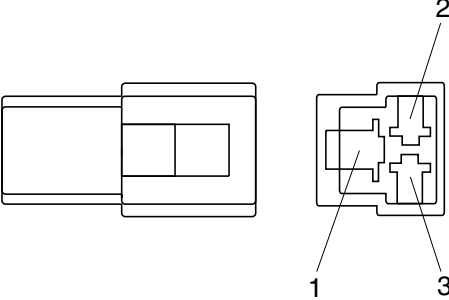
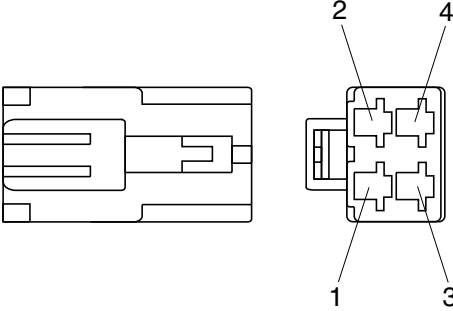
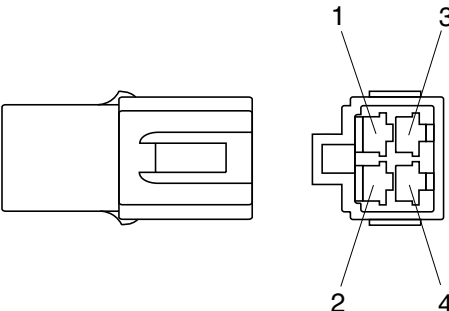
No. of pin	Receptacle connector (female)	Plug connector (male)
1	 <p data-bbox="687 680 836 707">S810-001202</p>	 <p data-bbox="1241 680 1390 707">S810-101202</p>
2	 <p data-bbox="687 1088 836 1115">S810-002202</p>	 <p data-bbox="1241 1088 1390 1115">S810-102202</p>
3	 <p data-bbox="687 1496 836 1523">S810-003202</p>	 <p data-bbox="1241 1496 1390 1523">S810-103202</p>
4	 <p data-bbox="687 1901 836 1928">S810-004202</p>	 <p data-bbox="1241 1901 1390 1928">S810-104202</p>

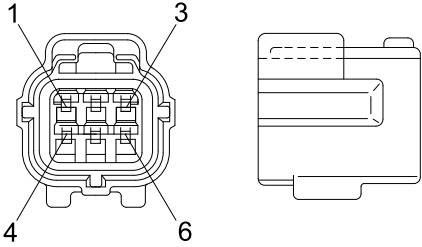
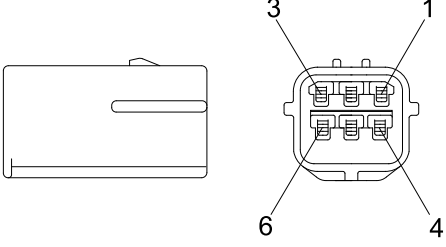
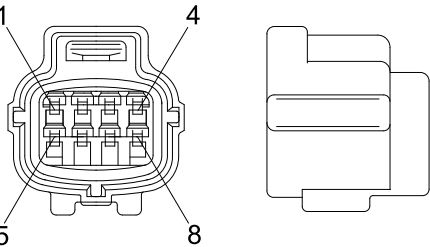
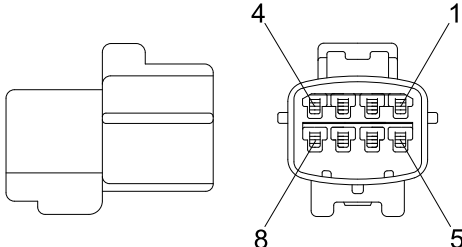
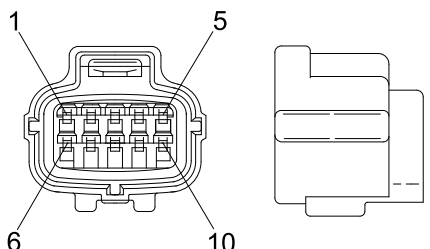
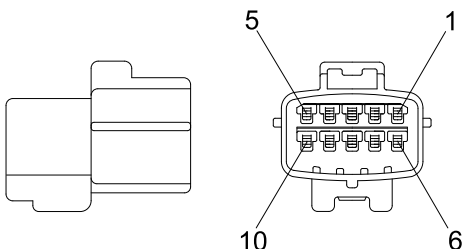
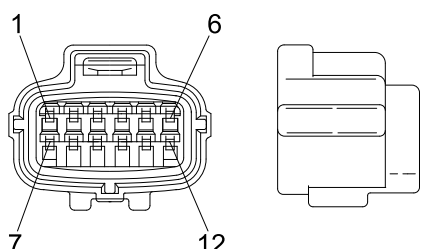
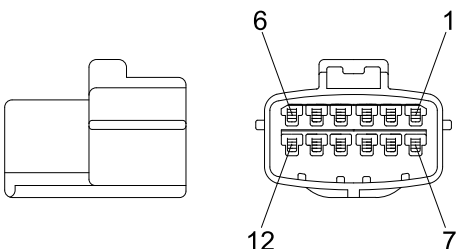
No. of pin	Receptacle connector (female)	Plug connector (male)
6	 <p data-bbox="686 638 837 672">S816-006002</p>	 <p data-bbox="1244 638 1396 672">S816-106002</p>
8	 <p data-bbox="686 1041 837 1075">S816-008002</p>	 <p data-bbox="1244 1041 1396 1075">S816-108002</p>
10	 <p data-bbox="686 1444 837 1478">S816-010002</p>	 <p data-bbox="1244 1444 1396 1478">S816-110002</p>
12	 <p data-bbox="686 1848 837 1881">S816-012002</p>	 <p data-bbox="1244 1848 1396 1881">S816-112002</p>

GROUP 3 AUTOMATIC DECELERATION SYSTEM

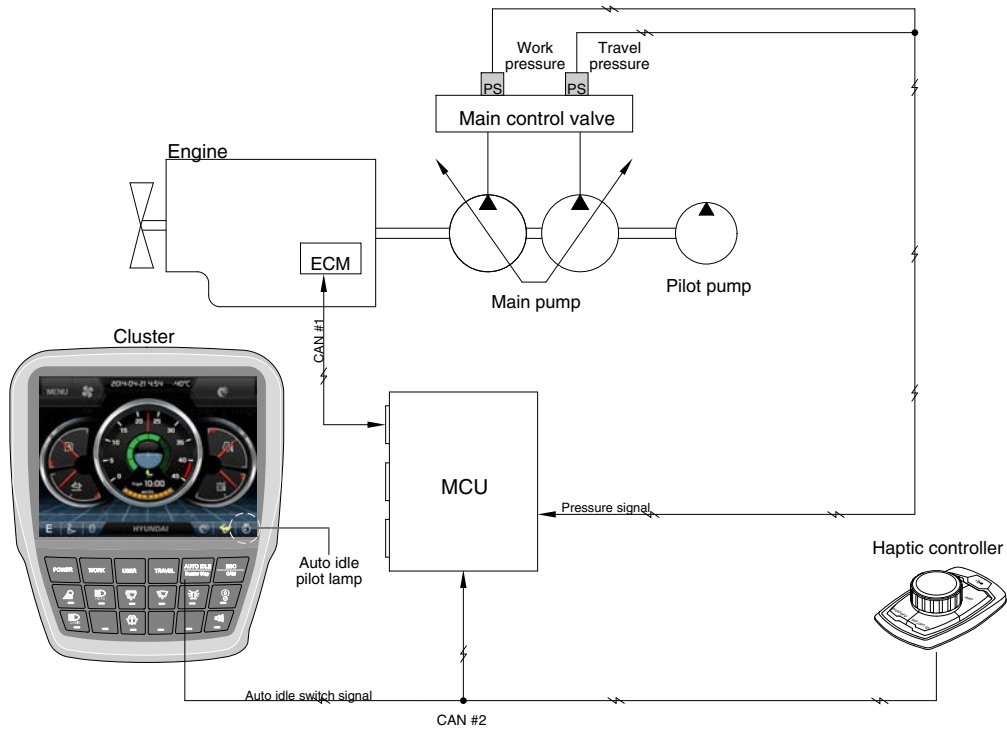

480F5MS16

1. WHEN AUTO IDLE PILOT LAMP ON

When all of the work equipment control levers including swing and travel levers are at neutral for 4 seconds, MCU sends throttle command to ECM to reduce the engine speed to 1000 rpm. If the control levers are at neutral for 1 minute, MCU reduces the engine speed to 800 rpm. As the result of reducing the engine speed, fuel consumption and noise are effectively cut down during non-operation of the control levers.

When the Auto idle pilot lamp is turned off by pressing the switch or any control lever is operated, the reduced engine speed rises upto the speed before deceleration in a second.

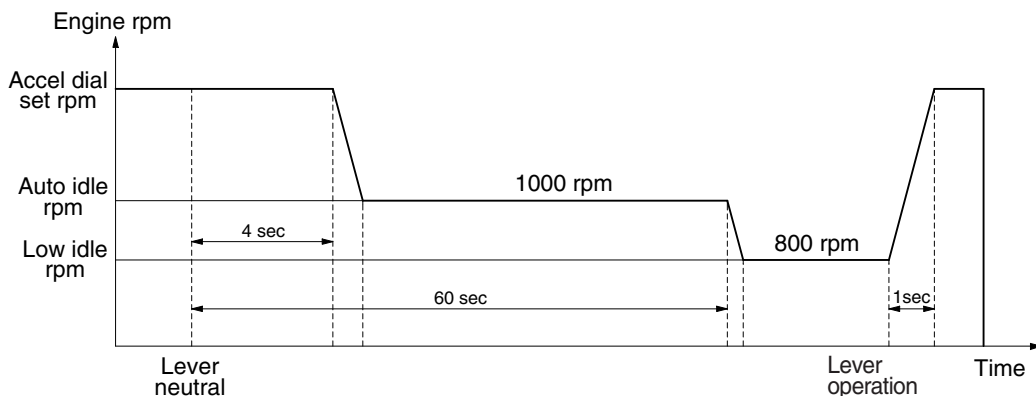

480F5MS03

2. WHEN AUTO IDLE PILOT LAMP OFF

The engine speed can be set as desired using the accel dial switch, and even if the control levers are neutral, the engine speed is not reduced.

※ Auto idle function can be activated when accel dial position is over 4.

GROUP 12 ANTI-RESTART SYSTEM

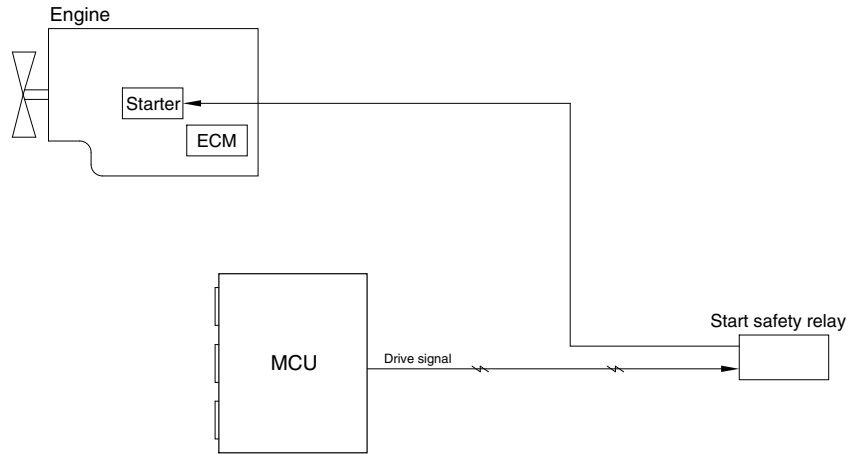

300L5MS12

1. ANTI-RESTART FUNCTION

After a few seconds from the engine starts to run, MCU turns off the start safety relay to protect the starter from inadvertent restarting.

DTC		Diagnostic Criteria	Application		
HCESPN	FMI		G	C	W
167		(Detection) (When Travel Speed Solenoid is Off) 10 seconds continuous, Travel Speed Solenoid drive unit Measurement Voltage $\leq 3.0V$ (Cancellation) (When Travel Speed Solenoid is Off) 3 seconds continuous, Travel Speed Solenoid drive unit Measurement Voltage $> 3.0V$		●	
	4	(When Parking mode is not) (Detection) (When Travel Speed Solenoid is Off) 10 seconds continuous, Travel Speed Solenoid drive unit Measurement Voltage $\leq 3.0V$ (Cancellation) (When Travel Speed Solenoid is Off) 3 seconds continuous, Travel Speed Solenoid drive unit Measurement Voltage $> 3.0V$			●
	6	(Detection) (When Travel Speed Solenoid is On) 10 seconds continuous, Travel Speed Solenoid drive current $> 4.5 A$ (Cancellation) (When Travel Speed Solenoid is On) 3 seconds continuous, Travel Speed Solenoid drive current $\leq 4.5 A$	●		
	(Results / Symptoms) 1. Control Function – driving in 1/2 transmission operation failure (Checking list) 1. CN-70 (#1) – CN-52(#20) Checking Open/Short 2. CN-70 (#2) – CN-45(#B+ term) Checking Open/Short				

※ Some error codes are not applied to this machine.

G : General

C : Crawler Type

W : Wheel Type

DTC		Diagnostic Criteria	Application		
HCESPN	FMI		G	C	W
525	4	(Detection) (When Ram Lock Solenoid is Off) 10 seconds continuous, Ram Lock Solenoid drive unit Measurement Voltage $\leq 3.0V$ (Cancellation) (When Ram Lock Solenoid is Off) 3 seconds continuous, Ram Lock Solenoid drive unit Measurement Voltage $> 3.0V$			●
	6	(Detection) (When Ram Lock Solenoid is On) 10 seconds continuous, Ram Lock Solenoid drive current $> 6.5 A$ (Cancellation) (When Ram Lock Solenoid is On) 3 seconds continuous, Ram Lock Solenoid drive current $\leq 6.5 A$			●
(Results / Symptoms) 1. Control Function – Ram lock control operation failure (Checking list) 1. CN-69 (#1) – CN-54 (#8) Checking Open/Short 2. CN-69 (#2) – CN-45 (#B+ term) Checking Open/Short					
527	4	(Detection) (When Creep Solenoid is Off) 10 seconds continuous, Creep Solenoid drive unit Measurement Voltage $\leq 3.0V$ (Cancellation) (When Creep Solenoid is Off) 3 seconds continuous, Creep Solenoid drive unit Measurement Voltage $> 3.0V$			●
	6	(Detection) (When Creep Solenoid is On) 10 seconds continuous, Creep Solenoid drive current $> 6.5 A$ (Cancellation) (When Creep Solenoid is On) 3 seconds continuous, Creep Solenoid drive current $\leq 6.5 A$			●
(Results / Symptoms) 1. Control Function – Creep mode operation failure (Checking list) 1. CN-206 (#1) – CN-54 (#7) Checking Open/Short 2. CN-206 (#2) – CN-45 (#B+ term) Checking Open/Short					

※ Some error codes are not applied to this machine.

G : General

C : Crawler Type

W : Wheel Type

Fault code J1939 SPN J1939 FMI	Name	Description
2558 111 4	Engine coolant level	Coolant level sensor, short circuit to ground
107D 131 2	Engine exhaust back pressure	Exhaust pressure sensor, not plausible
0473 131 3	Engine exhaust back pressure	Exhaust pressure sensor, short circuit to +24V
0472 131 4	Engine exhaust back pressure	Exhaust pressure sensor, short circuit to ground or open load
106B 131 7	Engine exhaust back pressure	Exhaust pressure sensor and boost pressure sensor do not correlate
1078 131 8	Engine exhaust back pressure	Exhaust pressure sensor, faulty
16CC 131 9	Engine exhaust back pressure	Exhaust pressure sensor, stuck
106D 131 10	Engine exhaust back pressure	Exhaust pressure sensor and ambient pressure sensor do not correlate
1414 131 15	Engine exhaust back pressure	Exhaust pressure, high exhaust pressure during normal fueling
1413 131 16	Engine exhaust back pressure	Exhaust pressure, high exhaust pressure during motoring, no fueling
1415 131 18	Engine exhaust back pressure	Exhaust pressure, low exhaust pressure during exhaust brake
1068 131 20	Engine exhaust back pressure	Exhaust pressure too high, not plausible
106A 131 21	Engine exhaust back pressure	Exhaust pressure too low, not plausible
0103 132 0	Engine intake air mass flow rate	Mass flow sensor, short circuit to +24V
0102 132 1	Engine intake air mass flow rate	Mass flow sensor, short circuit to ground or open load
0101 132 2	Engine intake air mass flow rate	Mass flow sensor, faulty

※ Some fault codes are not applied to this machine.

Fault code J1939 SPN J1939 FMI	Name	Description
1193 655 8	Engine injector cylinder 5	Injector cyl. 5, over or under fueling
12C4 655 10	Engine injector cylinder 5	Fault with sensors/actuators for the particulate filter
119D 655 13	Engine injector cylinder 5	Injector trim code version error, injector cyl. 5
11E4 655 15	Engine injector cylinder 5	Cylinder 5 torque error
11D4 655 16	Engine injector cylinder 5	Cylinder 5 injector fault, high torque
11DC 655 18	Engine injector cylinder 5	Cylinder 5 injector fault, low torque
0275 655 20	Engine injector cylinder 5	Cylinder 5 balancing min or max
11A6 656 1	Engine injector cylinder 6	Two or more injectors with the same trim code, injector cyl. 6
117D 656 2	Engine injector cylinder 6	Injector trim code, checksum error injector cyl. 6
0206 656 5	Engine injector cylinder 6	Injector cyl. 6 cable/injector open load
1171 656 6	Engine injector cylinder 6	Injector cyl. 6 cable/injector short circuit
1155 656 7	Engine injector cylinder 6	Injection error, physical cylinder 6
1194 656 8	Engine injector cylinder 6	Injector cyl. 6, over or under fueling
119E 656 13	Engine injector cylinder 6	Injector trim code version error, injector cyl. 6
11E5 656 15	Engine injector cylinder 6	Cylinder 6 torque error
11D5 656 16	Engine injector cylinder 6	Cylinder 6 injector fault, high torque

※ Some fault codes are not applied to this machine.

CLICK HERE TO **DOWNLOAD** THE COMPLETE MANUAL

- Thank you very much for reading the preview of the manual.
- You can download the complete manual from: www.heydownloads.com by clicking the link below



- Please note: If there is no response to CLICKING the link, please download this PDF first and then click on it.

CLICK HERE TO **DOWNLOAD** THE COMPLETE MANUAL

Fault code J1939 SPN J1939 FMI	Name	Description
0426 3241 2	After treatment - exhaust gas temperature	Upstream catalyst temperature sensor not plausible.
104D 3241 3	After treatment - exhaust gas temperature	Upstream catalyst temperature sensor not plausible, too high
0427 3241 4	After treatment - exhaust gas temperature	Upstream catalyst temperature sensor not plausible, short circuit
0425 3241 5	After treatment - exhaust gas temperature	Upstream catalyst temperature sensor not plausible, open circuit
104F 3241 8	After treatment - exhaust gas temperature	Upstream catalyst temperature sensor not plausible, too high
16CD 3241 10	After treatment - exhaust gas temperature	Upstream catalyst temperature sensor not plausible.
20ED 3241 16	After treatment - exhaust gas temperature	Upstream catalyst temperature too high
104E 3241 18	After treatment - exhaust gas temperature	Upstream catalyst temperature sensor not plausible, too low
16FF 3241 19	After treatment - exhaust gas temperature	CAN Error from Exhaust Temperature Sensors
1803 3242 0	After treatment - DPF intake gas temp.	Upstream DPF temperature sensor, too high
16FC 3242 7	After treatment - DPF intake gas temp.	Upstream DPF temperature sensor, not plausible
2080 3242 9	After treatment - DPF intake gas temp.	Upstream DPF temperature sensor, not plausible
200F 3242 10	After treatment - DPF intake gas temp.	Upstream DPF temperature too high during normal condition
200E 3242 16	After treatment - DPF intake gas temp.	Upstream DPF temperature too high during regeneration
12CF 3245 19	After treatment - exhaust gas temperature	Auxiliary Temperature Sensor Error on CAN
12CB 3246 2	After treatment - DPF outlet gas temp.	Downstream DPF temperature sensor error

※ Some fault codes are not applied to this machine.

Fault code J1939 SPN J1939 FMI	Name	Description
0475 5543 6	Engine Exhaust Brake Actuator Command	Exhaust brake actuator, faulty
1411 5543 7	Engine Exhaust Brake Actuator Command	Exhaust brake actuator, stuck in closed position
1428 5543 12	Engine Exhaust Brake Actuator Command	Exhaust brake actuator, control fault
1408 5543 13	Engine Exhaust Brake Actuator Command	Exhaust brake actuator, fault with stop position
1409 5543 16	Engine Exhaust Brake Actuator Command	Exhaust brake actuator, over temperature
1403 5543 19	Engine Exhaust Brake Actuator Command	Exhaust brake actuator, CAN timeout
0476 5543 21	Engine Exhaust Brake Actuator Command	Exhaust brake actuator, error
205B 5743 2	Aftertreatment SCR Temperature	Reductant tank temperature sensor, not plausible
205C 5743 4	Aftertreatment SCR Temperature	Reductant tank temperature sensor, short circuit
205A 5743 5	Aftertreatment SCR Temperature	Reductant tank temperature sensor, open load
202C 5745 3	Aftertreatment Diesel Exhaust Fluid Dosing Unit Heater	SCR water valve, short circuit to battery
202A 5745 5	Aftertreatment Diesel Exhaust Fluid Dosing Unit Heater	SCR water valve, open load
207F 5841 1	Diesel Exhaust Fluid Quality Malfunction	SCR main unit, reductant quality too low

3. CLUSTER CONNECTOR

1) CN-56A

No.	Name	Signal
1	Battery 24V	20~32V
2	Power IG (24V)	20~32V
3	GND	-
4	CAN 1 (H)	0~5V
5	CAN 1 (L)	0~5V
6	CAN 2 (H)	20~32V
7	CAN 2 (L)	20~32V
8	RS-232 (RX)	±15V
9	RS-232 (TX)	±15V
10	Aux left	0~5V
11	Aux right	0~5V
12	Aux GND	-

2) CN-56B

No.	Name	Signal
1	CAM 6.5V	6.3~6.7V
2	CAM GND	-
3	CAM DIFF (H)	0~5V
4	CAM DIFF (L)	0~5V
5	CAM 1	NTSC signal
6	CAM 2	NTSC signal
7	CAM 3	NTSC signal
8	CAM shield	-

NTSC : National Television System Committee

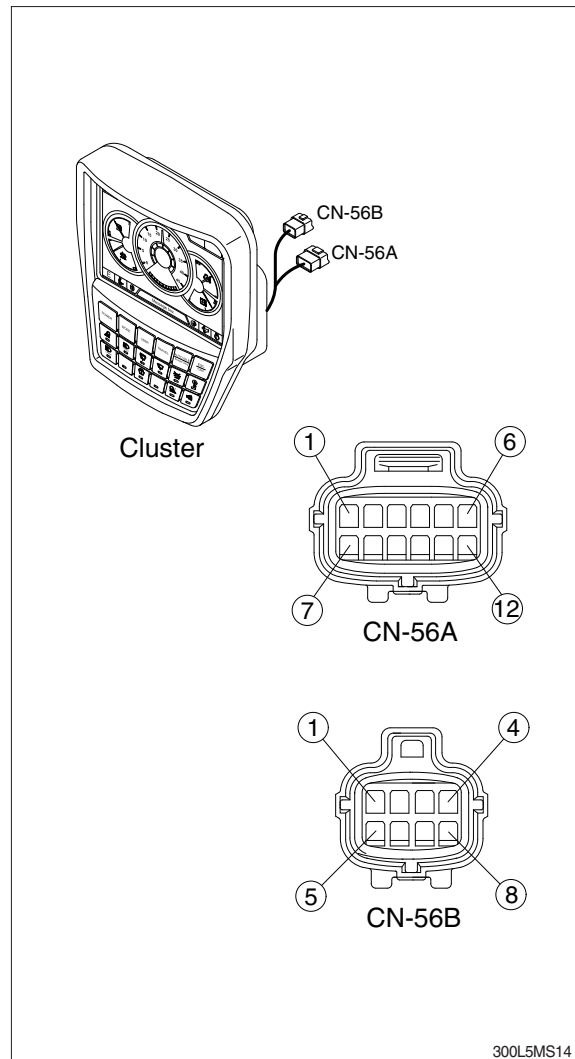

300L5MS14

(3) Preheat pilot lamp



290F3CD79

- ① Turning the start key switch ON position starts preheating in cold weather.
- ② Start the engine after this lamp is OFF.

(4) Warming up pilot lamp

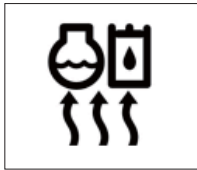

290F3CD80

- ① This lamp is turned ON when the coolant temperature is below 30°C (86°F).
- ② The automatic warming up is cancelled when the engine coolant temperature is above 30°C, or when 10 minutes have passed since starting the engine.

(5) Decel pilot lamp



290F3CD81

- ① Operating one touch decel switch on the RCV lever makes the lamp ON.
 - ② Also, the lamp will be ON and engine speed will be lowered automatically to save fuel consumption when all levers and pedals are at neutral position, and the auto idle function is selected.
- ※ **One touch decel is not available when the auto idle pilot lamp is turned ON.**
- ※ **Refer to the operator's manual page 3-36.**

(6) Fuel warmer pilot lamp

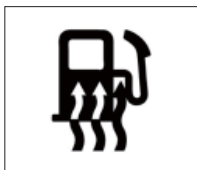

290F3CD82

- ① This lamp is turned ON when the coolant temperature is below 10°C (50°F) or the hydraulic oil temperature 20°C (68°F).
- ② The automatic fuel warming is cancelled when the engine coolant temperature is above 60°C, and the hydraulic oil temperature is above 45°C since the start switch was ON position.

(7) Maintenance pilot lamp



290F3CD83

- ① This lamp will be ON when the consuming parts are needed to change or replace. It means that the change or replacement interval of the consuming parts remains below 30 hours.
 - ② Check the message in maintenance information of main menu. Also, this lamp lights ON for 3 minutes when the start switch is ON position.
- ※ **Refer to the page 5-86.**

(3) Monitoring

① Active fault



- The active faults of the MCU, engine ECM or air conditioner can be checked by this menu.

② Logged fault



- The logged faults of the MCU, engine ECM or air conditioner can be checked by this menu.

③ Delete logged fault



- The logged faults of the MCU, engine ECM or air conditioner can be deleted by this menu.

④ Monitoring

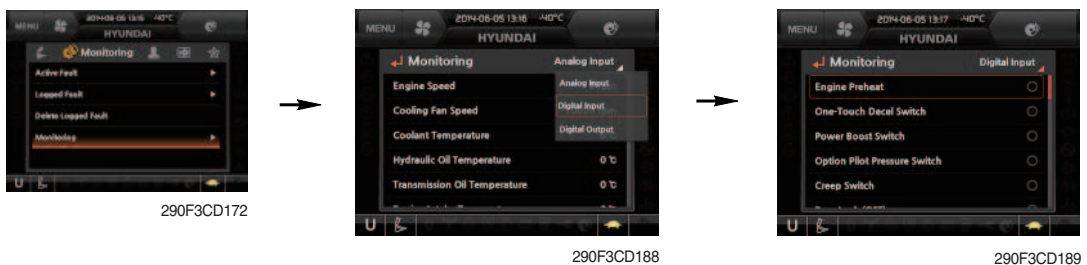

- The machine status such as the engine rpm, oil temperature, voltage and pressure etc. can be checked by this menu (Analog input).
- The switch status or output status can be confirmed by this menu (Digital input & Digital output).
- The activated switch or output pilot lamps ● are light ON.

② Tripmeter

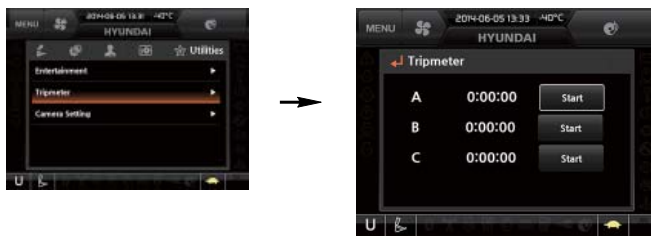

- Maximum 3 kinds of tripmeters can be used at the same time.
- Each tripmeter can be turned on by choosing "Start" while it also can be turned off by choosing "Stop".
- If the tripmeter icon is activated in the operation screen, it can be controlled directly there.

③ Camera setting

- If the rear camera is not installed on the machine, set disable.
- If the rear camera installed on the machine, set enable.



- In the operation screen, rear camera screen show up when ESC/CAM button is pushed.



STEP 4. Inspect the trouble actually on the machine

In case that some trouble cannot be confirmed, obtain the details of the malfunction from the operator.

Also, check if there are any incomplete connections of the wire harnesses or not.

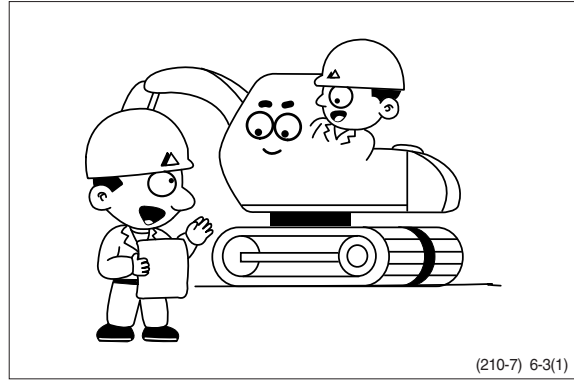

STEP 5. Perform troubleshooting

According to where the trouble parts are located, hydraulic & mechanical system part or electrical system part or mechatronics system part, perform troubleshooting the machine refer to the each system part's troubleshooting process diagram.

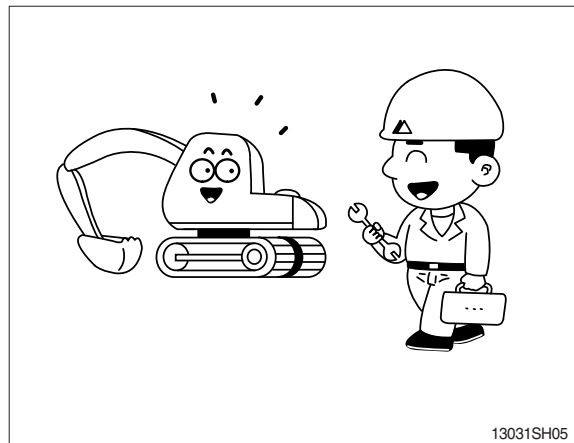

STEP 6. Trace a cause

Before reaching a conclusion, check the most susceptible causes again. Try to trace what the real cause of the trouble is.

Make a plan of the appropriate repairing procedure to avoid consequential malfunctions.

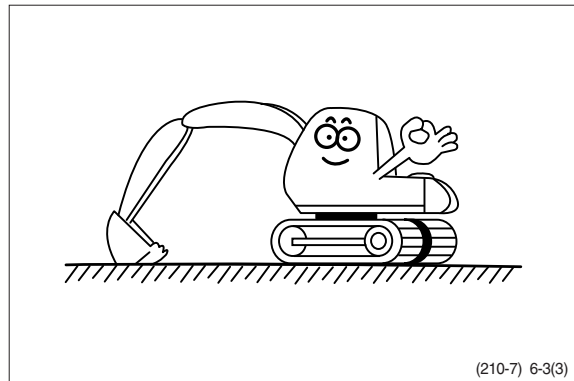

5. TRAVEL SYSTEM

1) TRAVEL DOES NOT FUNCTION AT ALL ON ONE SIDE

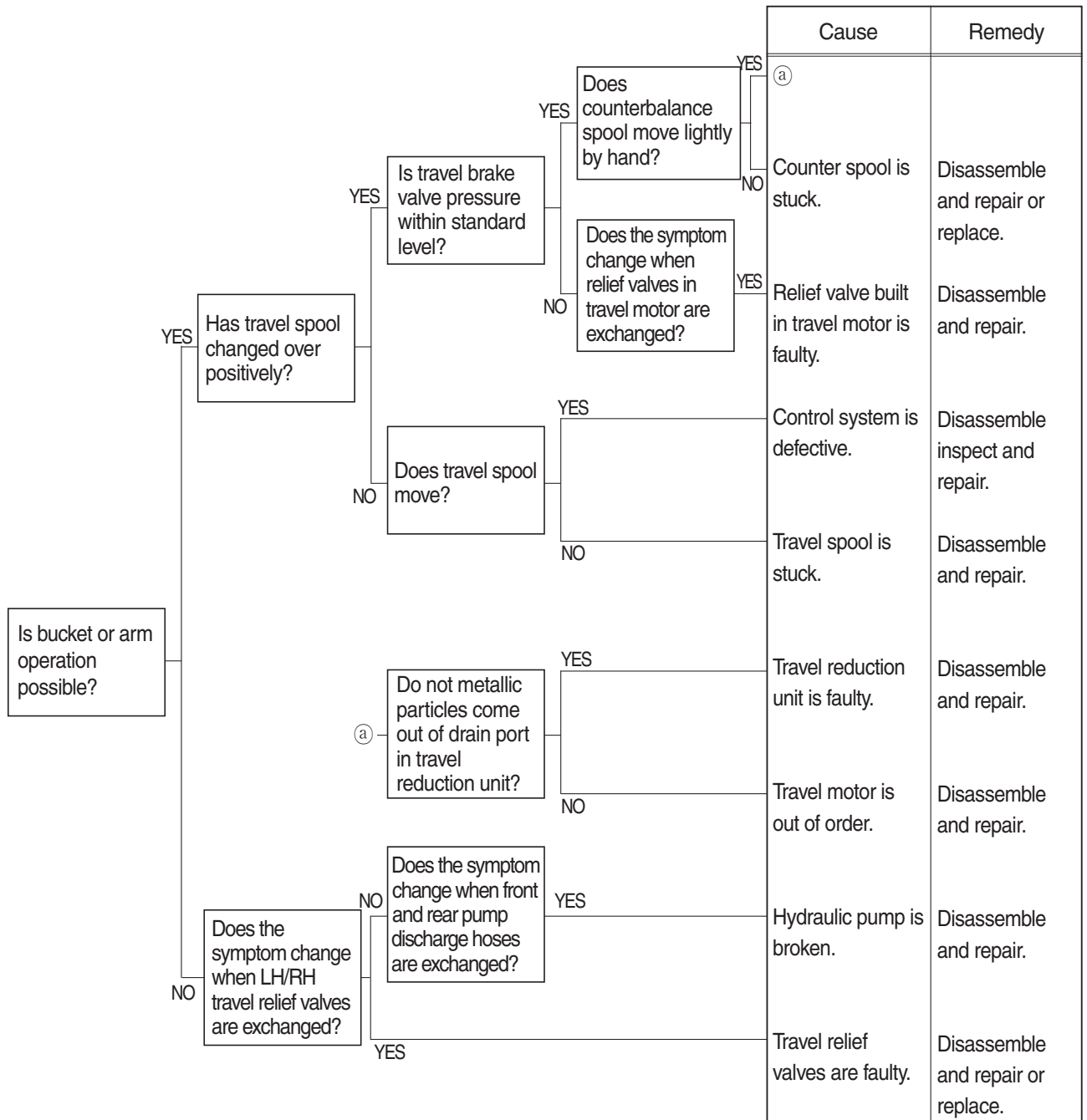

※ HOW TO CHECK INTERNAL BOOM CYLINDER LEAKAGE

1. Lower the bucket teeth to the ground with bucket cylinder fully retracted and arm cylinder rod retracted almost in full.

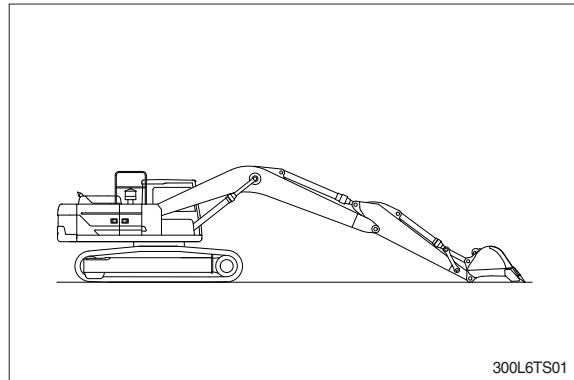

2. Disconnect hose (A) from rod side of boom cylinder and drain oil from cylinders and hose. (put cups on piping and hose ends)

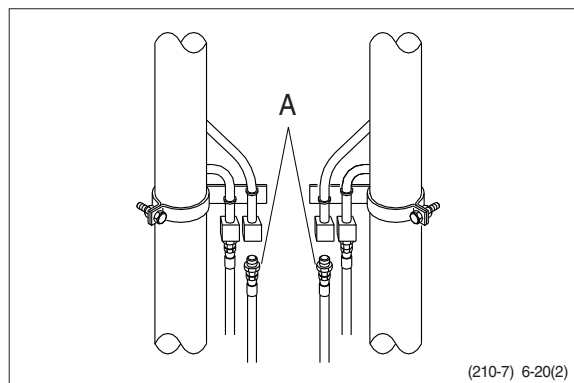

3. Raise bucket OFF the ground by retracting the arm cylinder rod.

If oil leaks from piping side and boom cylinder rod is retracted there is an internal leak in the cylinder.

If no oil leaks from piping side and boom cylinder rod is retracted, there is an internal leak in the control valve.

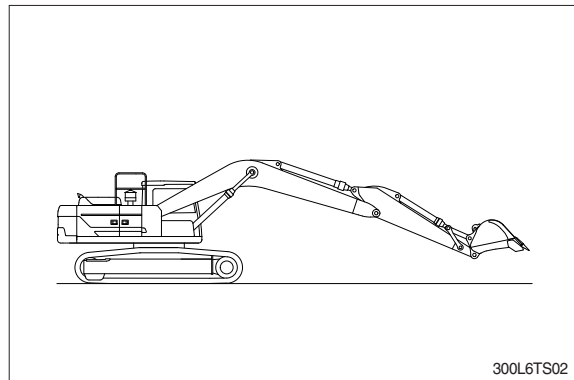

10. WHEN SAFETY SOLENOID DOES NOT OPERATE

- Before disconnecting the connector, always turn the starting switch OFF.
- Before carrying out below procedure, check all the related connectors are properly inserted and short of fuse No. 26.
- After checking, insert the disconnected connectors again immediately unless otherwise specified.

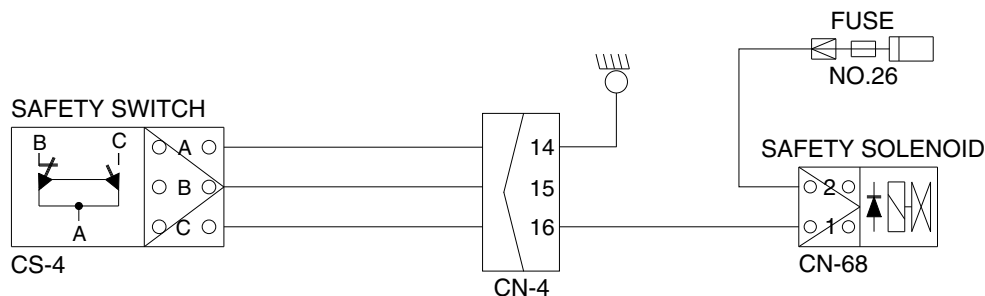
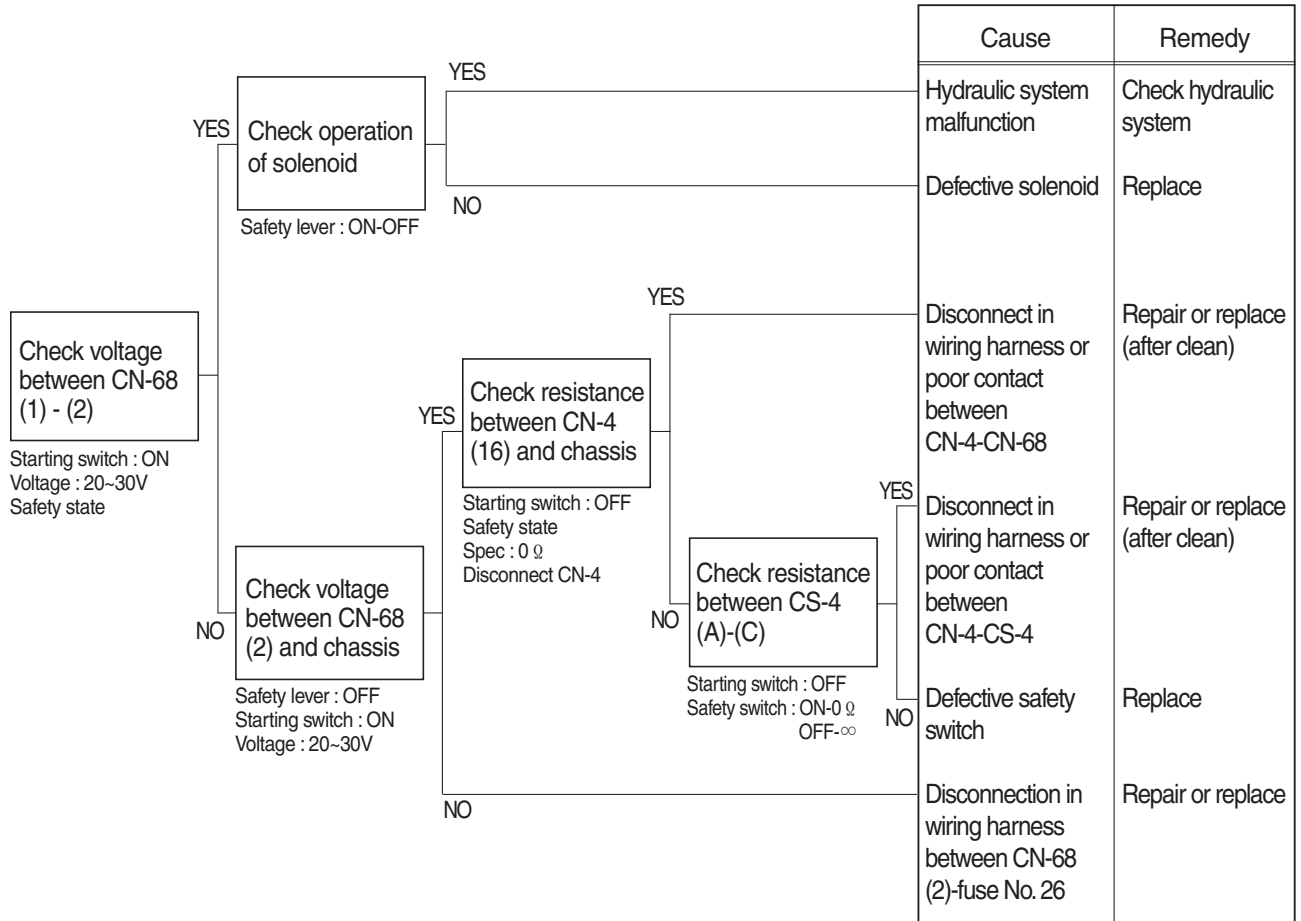

480L6ES03

2) TEST PROCEDURE

(1) Test 4 : Check electric current at EPPR valve.

- ① Disconnect connector CN-75 from EPPR valve.
- ② Insert the adapter to CN-75 and install multimeter as figure.
- ③ Start engine.
- ④ Set S-mode and cancel auto decel mode.
- ⑤ Position the accel dial at 10.
- ⑥ If rpm show approx 1750 ± 50 rpm disconnect one wire harness from EPPR valve.
- ⑦ Check electric current at bucket circuit relief position.

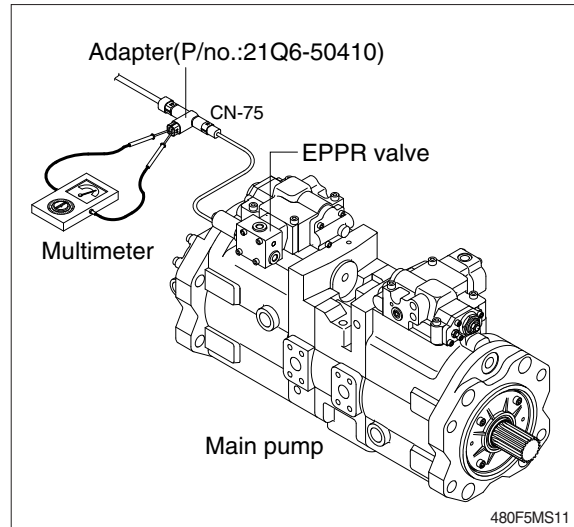

(2) Test 5 : Check pressure at EPPR valve.

- ① Remove plug and connect pressure gauge as figure.
 - Gauge capacity : 0 to 50 kgf/cm²
(0 to 725 psi)
- ② Start engine.
- ③ Set S-mode and cancel auto decel mode.
- ④ Position the accel dial at 10.
- ⑤ If rpm show approx 1750 ± 50 rpm check pressure at relief position of bucket circuit by operating bucket control lever.
- ⑥ If pressure is not correct, adjust it.
- ⑦ After adjust, test the machine.

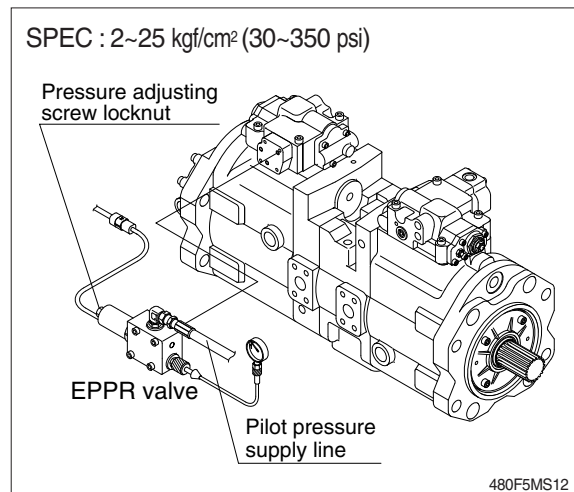

8. MALFUNCTION OF NEGATIVE 1 PRESSURE SENSOR

· Fault code : HCESPN 123, FMI 0~4

※ Before carrying out below procedure, check all the related connectors are properly inserted.

1) INSPECTION PROCEDURE

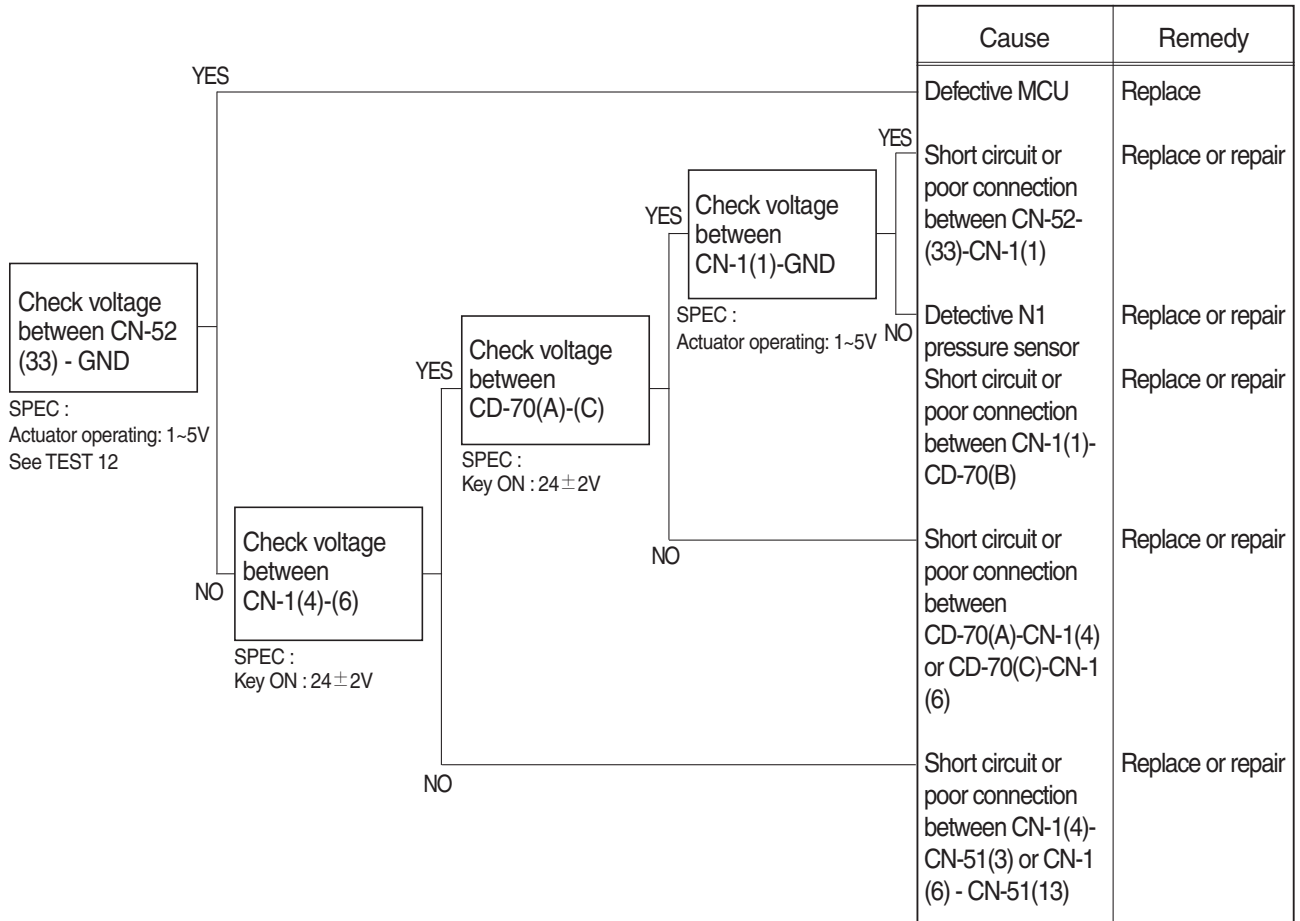

Wiring diagram

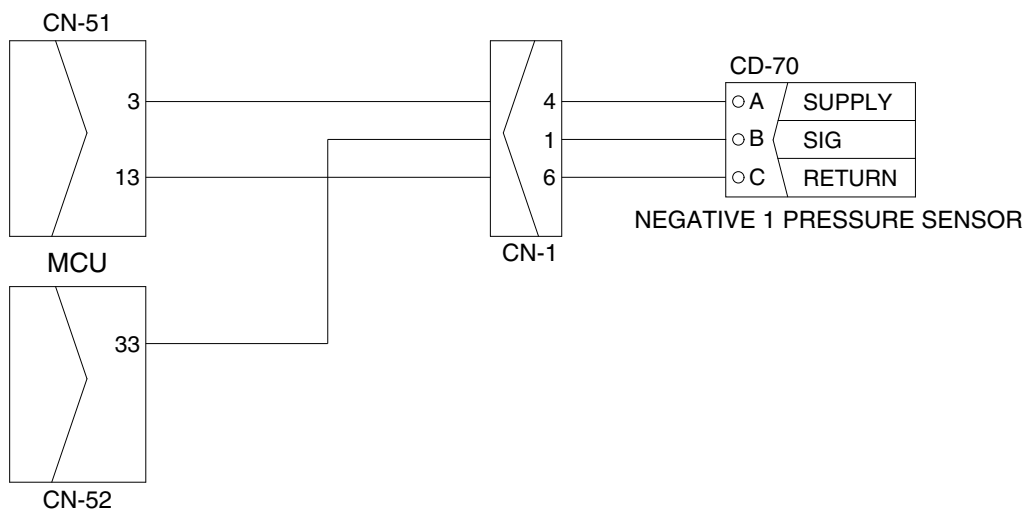

13. MALFUNCTION OF BOOM DOWN PRESSURE SENSOR

· Fault code : HCESPN 128, FMI 0~4

※ Before carrying out below procedure, check all the related connectors are properly inserted.

1) INSPECTION PROCEDURE

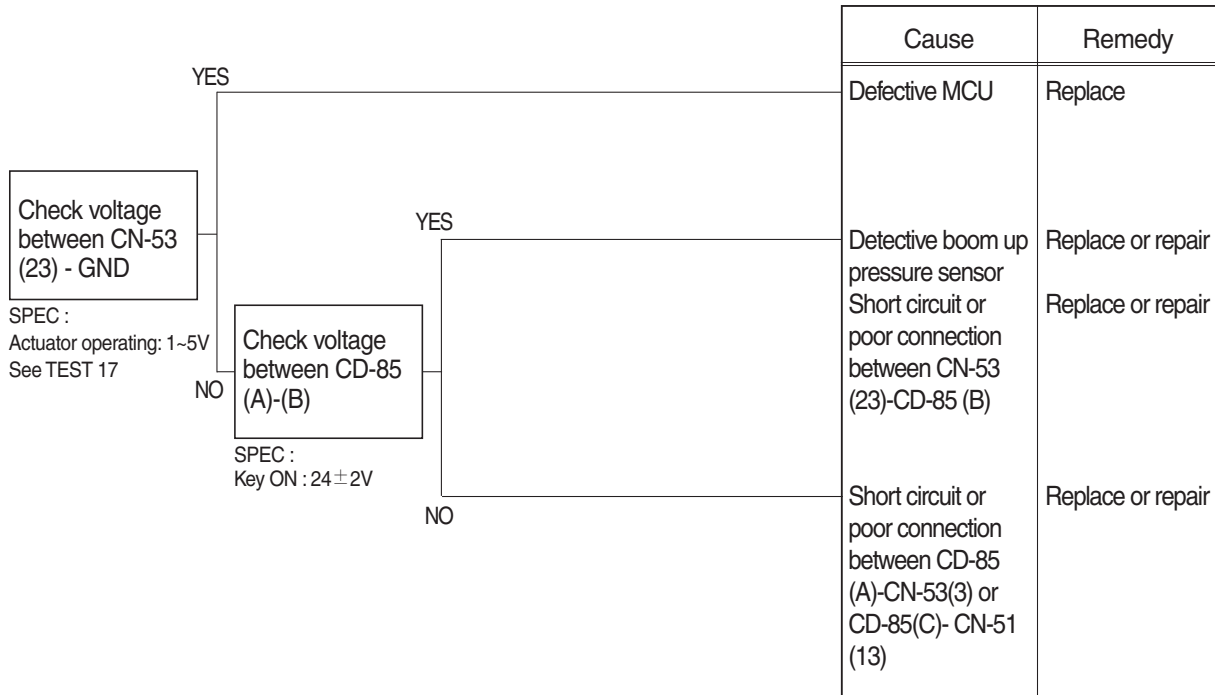

Wiring diagram

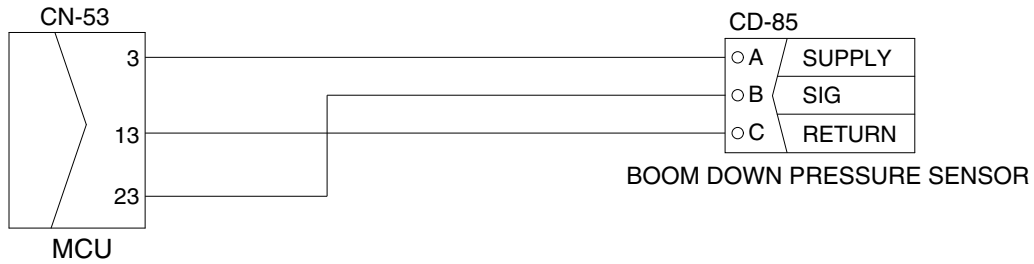

300L6MS25

3) TRAVEL SPEED

(1) Measure the time required for the excavator to travel a 20 m test track.

(2) Preparation

- ① Adjust the tension of both tracks to be equal.
- ② Prepare a flat and solid test track 20m in length, with extra length of 3 to 5 m on both ends for machine acceleration and deceleration.
- ③ Hold the bucket 0.3 to 0.5 m above the ground with the arm and bucket rolled in.
- ④ Keep the hydraulic oil temperature at $50 \pm 5^\circ\text{C}$.

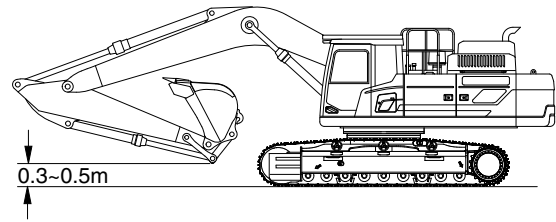

480A7MS02

(3) Measurement

- ① Measure both the low and high speeds of the machine.
- ② Before starting either the low or high speed tests, adjust the travel mode switch to the speed to be tested, then select the following switch positions.
 - Power mode switch : P mode
- ③ Start traveling the machine in the acceleration zone with the travel levers at full stroke.
- ④ Measure the time required to travel 20 m.
- ⑤ After measuring the forward travel speed, turn the upperstructure 180° and measure the reverse travel speed.
- ⑥ Repeat steps ④ and ⑤ three times in each direction and calculate the average values.

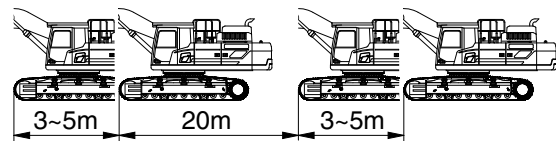

480A7MS03

(4) Evaluation

The average measured time should meet the following specifications.

Unit : Seconds / 20 m

Model	Travel speed	Standard	Maximum allowable	Remarks
HX480 L HX520 L	1 Speed	21.2 ± 2.0	29	
	2 Speed	13.2 ± 1.0	18.7	

12) CONTROL LEVER STROKE

(1) Measure each lever stroke at the lever top using a ruler.

※ When the lever has play, take a half of this value and add it to the measured stroke.

(2) Preparation

Keep the hydraulic oil temperature at $50 \pm 5^{\circ}\text{C}$.

(3) Measurement

- ① Stop the engine.
- ② Measure each lever stroke at the lever top from neutral to the stroke end using a ruler.
- ③ Repeat step ② three times and calculate the average values.

(4) Evaluation

The measured drift should be within the following specifications.

Unit : mm

Model	Kind of lever	Standard	Maximum allowable	Remarks
HX480 L HX520 L	Boom lever	90 ± 10	115	
	Arm lever	90 ± 10	115	
	Bucket lever	90 ± 10	115	
	Swing lever	90 ± 10	115	
	Travel lever	142 ± 10	178	

Check item	Measuring method	Criteria	Allowable	Remedy
Parking brake torque	After completion of assembly, set the torque wrench on the shaft end, and measure the braking torque generated when the shaft starts to rotate	92.6 kgf · m (670 lbf · ft)	82.8 kgf · m (599 lbf · ft)	Replace all of separator, friction plates and springs
Standard of replacing friction and separating plate. When measuring parking brake torque, it needs to disassemble traveling unit to motor and reduction gear portion, and it's so hard. The right allowable value is a standard of replacing friction and separating plate. If it is impossible to disassemble traveling unit, refer to the right value.	Measure the total thickness of 4 pieces of friction plate and 5 pieces of separating plate.	22.76 mm	Thickness : 21.3 mm	Replace all separating and friction plates and springs.

Check item	Measuring method	Judging criteria and remedy
Shaft	Measure the wear at contacting surface of oil seal (3) with the surface roughness tester	If the depth of shaft wear is less than 0.05 mm, the shaft is reusable. ※ In case of replacing the shaft (9), replace oil seal (3) at the same time.
Bearings	Replace bearings (10, 51) after decided hours	Replace bearings (10, 51) before hour meter of host machine indicates 10,000 hours. ※ In case replacing the bearings (10, 51), replace both inner and outer races at the same time. ※ Also the bearing shims (52) must be readjusted when replaced shaft (9) and/or bearings (10, 51). Contact dealers for jigs and tools required.
Splines	Replace if the wear of splines exceeds the allowable value	If the wear of splines is less than 0.3 mm, the spline is reusable.
Overload relief valve	Do not try to adjust the valve, since special hydraulic test bench is required for inspecting and adjusting the pressure	Replace relief valve part as an assembly each time the host machine works for 10,000 hours.

2. WORK EQUIPMENT

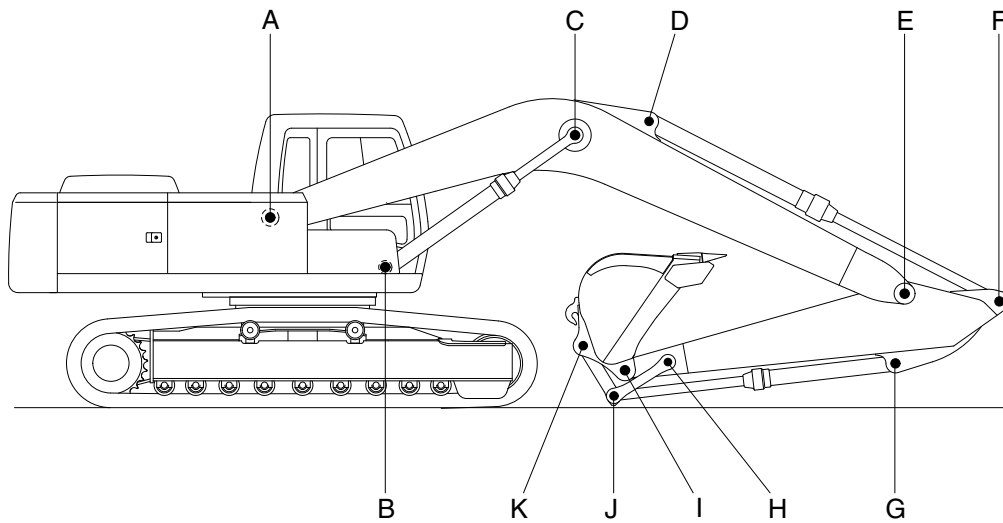

21077MS20

Unit : mm

Mark	Measuring point (Pin and Bushing)	Normal value	Pin		Bushing		Remedy & Remark
			Recomm. service limit	Limit of use	Recomm. service limit	Limit of use	
A	Boom Rear	125	124	123.5	125.5	126	Replacement
B	Boom Cylinder Head	120	119	118.5	120.5	121	
C	Boom Cylinder Rod	120	119	118.5	120.5	121	
D	Arm Cylinder Head	120	119	118.5	120.5	121	
E	Boom Front	125	124	123.5	125.5	126	
F	Arm Cylinder Rod	120	119	118.5	120.5	121	
G	Bucket Cylinder Head (HX480 L)	100	99	98.5	100.5	101	
	Bucket Cylinder Head (HX520 L)	110	109	108.5	110.5	111	
H	Arm Link	100	99	98.5	100.5	101	
I	Bucket and Arm Link (HX480 L)	100	99	98.5	100.5	101	
	Bucket and Arm Link (HX520 L)	120	119	118.5	120.5	121	
J	Bucket Cylinder Rod (HX480 L)	100	99	98.5	100.5	101	
	Bucket Cylinder Rod (HX520 L)	110	109	108.5	110.5	111	
K	Bucket Link (HX480 L)	100	99	98.5	100.5	101	
	Bucket Link (HX520 L)	120	119	118.5	120.5	121	

2) INSTALL

- (1) Carry out installation in the reverse order to removal.
- (2) Remove the suction strainer and clean it.
- (3) Replace return filter with new one.
- (4) Remove breather and clean it.
- (5) After adding oil to the hydraulic tank to the specified level.
- (6) Bleed the air from the hydraulic pump.
 - ① Remove the air vent plug (2EA).
 - ② Tighten plug lightly.
 - ③ Start the engine, run at low idling, and check oil come out from plug.
 - ④ Tighten plug.
- (7) Start the engine, run at low idling (3~5 minutes) to circulate the oil through the system.
- (8) Confirm the hydraulic oil level and check the hydraulic oil leak or not.

- (7) Fit valve plate (313) to valve cover (F, 311), and fit valve plate (314) to valve cover (R, 312), entering pin into pin hole.
 ※ Take care not to mistake suction / delivery directions of valve plate.

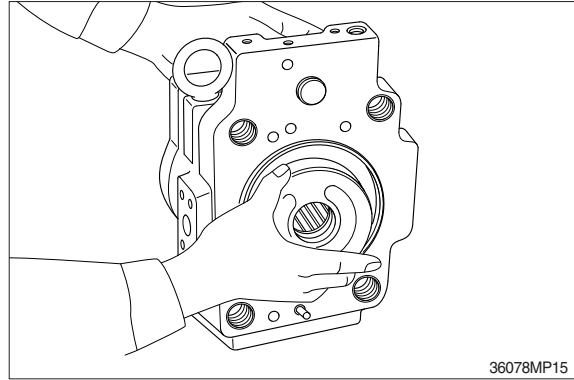

- (8) Fit valve block (R, 312) to pump casing (271) and fit spline coupling (114) and booster (130) to shaft (R, 113).
 ※ Take care not to mistake direction of valve cover.
 Fit valve cover with regulator up and with delivery flange left, viewed from front side.
 ※ Take care not to mistake direction of booster (130).
 (refer to the sectional drawing)

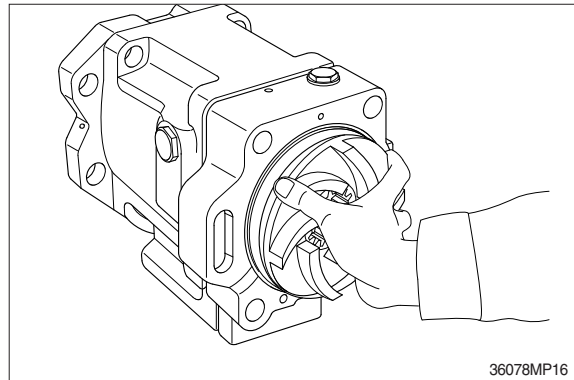

- (9) Fit valve cover (F, 311) to valve cover (R) and tighten hexagon socket head bolts (402).

- (10) Fit pump casing (271) with shaft (F, 111) to valve cover (F, 311) and tighten hexagon socket head bolts (401).
 ※ Mate spline phases of shaft (F) and spline coupling, with shaft (F) been rotating.

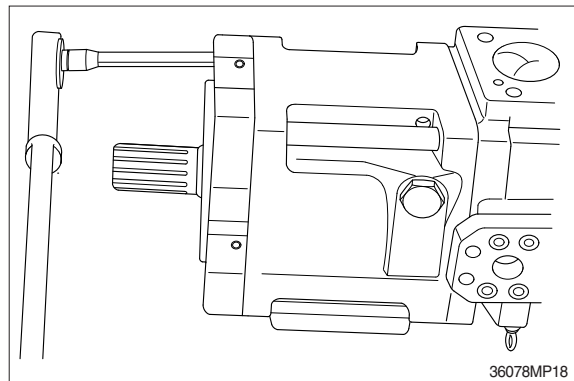

4) ASSEMBLY

(1) For assembly, reverse disassembly procedures, but pay attention to the following items.

① Always repair parts that were scored at disassembly.

② Get replacement parts ready beforehand.

Mixing of foreign matter will cause malfunction.

Therefore, wash parts well with cleaning oil, let them dry with jet air and handle

③ them in clean place.

Always tighten bolts, plugs, etc. to their

④ specified torques.

Do not fail to coat sliding surfaces with

⑤ clean hydraulic oil before assembly.

Replace seals such as O-ring with new ones as a rule.

(2) Put compensating rod (623) into compensating hole of casing (601).

(3) Put pin force-fitted in lever 1 (612) into groove of compensating rod and fit lever 1 to pin force-fitted in casing.

(4) Fit spool (652) and sleeve (651) into hole in spool of casing.

※ Confirm that spool and sleeve slide smoothly in casing without binding.

※ Pay attention to orientation of spool.

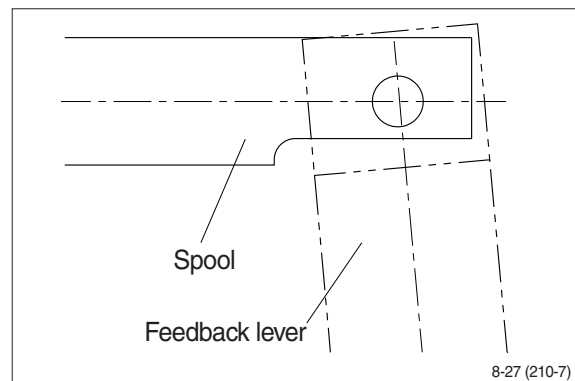

2) DISASSEMBLY

The figure in () shown after the part name in explanation sentence shows its number in the construction figures.

(1) Place control valve on working bench

- ※ Disassemble the valve in a clean and dry environment and pay careful attention not to damage the sealing flange faces.

(2) Main spool

- ① Loosen socket head bolts (63) and remove the pilot cap (32).
Pull out O-ring (52) from valve housing.



45078MC07

- ② Remove all spool (3~11) of subassembly itself from valve housing.
 - ※ Be careful not to be damaged while pulling out spools. Identify them with a tag to prevent from being mistaken at disassembly.



45078MC08

- ③ Spools sub assy (3, 4, 5, 6, 7, 8, 9, 10, 11).



45078MC10

(2) Disassemble cylinder block assy

- ① Disassemble piston assy (12) from cylinder block assy (8).

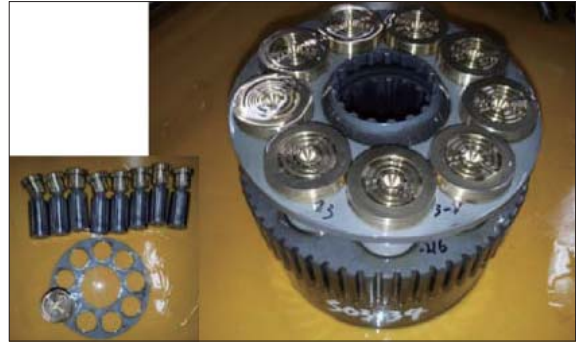

480L2SM18

- ② Disassemble ball guide (10) and springs (9) (cylinder block) from cylinder block assy (8).

- Ball guide × 1EA
- Spring × 9EA



480L2SM19

3. REMOVAL AND INSTALL OF REDUCTION GEAR

1) REMOVAL

- (1) Remove the swing motor assembly.
For details, see removal of swing motor assembly.
- (2) Sling reduction gear assembly (1) and remove mounting bolts (2).
- (3) Remove the reduction gear assembly.
 - Reduction gear device weight : 180 kgf · m
(396 lbf · ft)



2) INSTALL

- (1) Carry out installation in the reverse order to removal.
 - Tightening torque : 57.9 ± 8.7 kgf · m
(419 ± 62.9 lbf · ft)

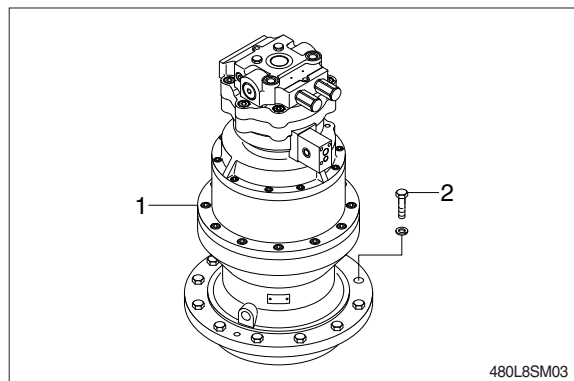



480L2SM73

(5) Assembling bearing cup & oil seal

- ① Put top, bottom bearing cup into casing.
(Use special jig for pressing. Pay attention to foreign materials while assembling bearing cup.)
- ※ Flip over casing to assemble oil seal.



480L2SM74



480L2SM75

2. TRAVEL MOTOR

1) STRUCTURE

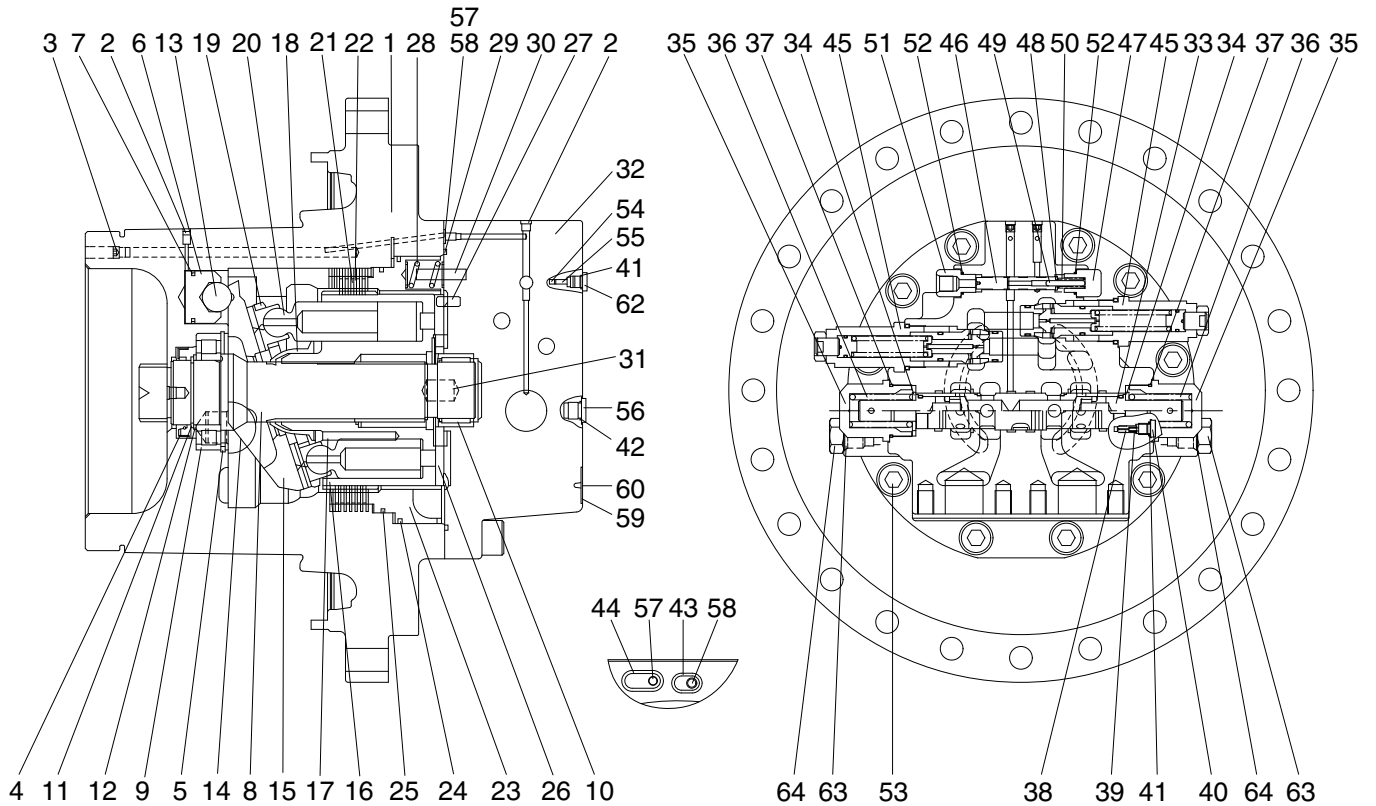

480F2TM02

1 Casing	22 Separate plate	43 O-ring
2 Plug	23 Parking piston	44 O-ring
3 Plug	24 D-ring	45 Relief valve assy
4 Oil seal	25 D-ring	46 Spool
5 Snap ring	26 Valve plate	47 Plug
6 Piston	27 Parallel pin	48 Spring seat
7 Piston seal	28 Spring	49 Parallel pin
8 Shaft	29 O-ring	50 Spring
9 Cylinder roller bearing	30 Spring pin	51 Connector
10 Needle bearing	31 Parallel pin	52 O-ring
11 Snap ring	32 Rear cover	53 Hex socket head bolt
12 Thrust plate	33 Main spool assy	54 Check valve
13 Steel ball	34 Spring seat	55 Spring
14 Pivot	35 Plug	56 Plug
15 Swash plate	36 Spring	57 Restrictor
16 Cylinder block	37 O-ring	58 Restrictor
17 Spring	38 Restrictor	59 Name plate
18 Guide ball	39 Spring	60 Rivet
19 Retainer plate	40 Plug	62 Plug
20 Piston assy	41 O-ring	63 Plug
21 Friction plate	42 O-ring	64 O-ring

(12) Install casing (1) into assembling jig.



480L2TM69

(13) Assemble plug (2), (3) into casing (1).



480L2TM70



480L2TM71

(14) Assemble oil-seal (3) into casing (1) with assembling jig.



480L2TM72

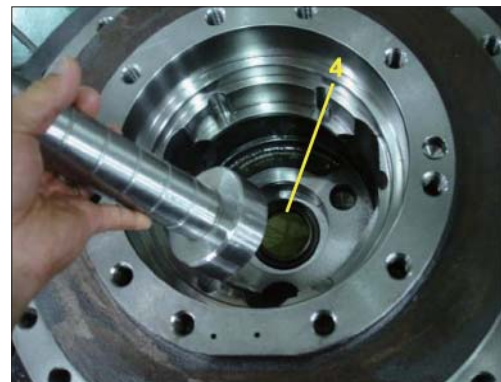

480L2TM73

(15) Insert assembled shaft assy in the direction of the arrow into casing(1) using a rubber mallet.



480L2TM74



480L2TM75

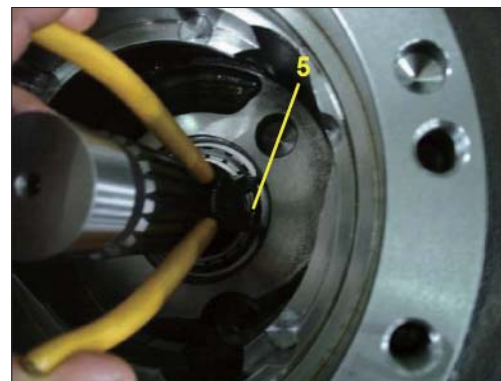

480L2TM76

(2) Put disassembled ring gear and housing on work table. Be sure to set floating seal upper side, and remove floating seal.

※ Do not re-use floating seal.

(3) Remove bolt-hex.socket head (M20×120L) connecting housing and ring gear using torque wrench.

(4) Put sharp tool into gap between ring gear and housing and tap it tenderly to separate gear and housing.

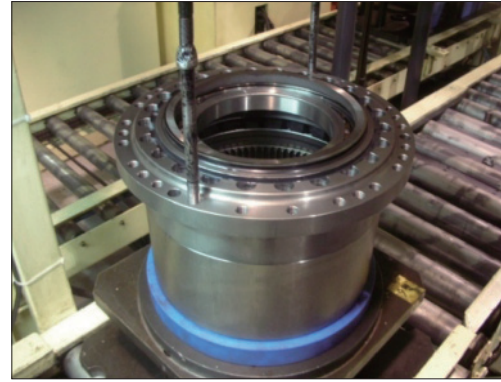

480L2TM212

9) DISASSEMBLE HOUSING COMPONENTS

Bolt-hex.socket head (M10×25L) connecting housing and seal cover using torque wrench, and remove seal cover.



480L2TM213

10) SEPARATE MOTOR CASING AND FLOATING SEAL

Pull floating seal in motor casing slowly and remove floating seal from motor casing.

※ Do not re-use floating seal.

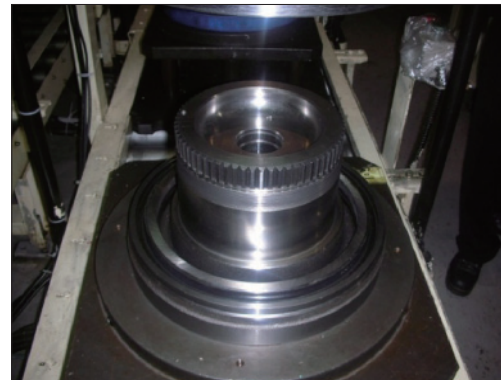

480L2TM211

11) NO.1 CARRIER ASS'Y DISASSEMBLE

(1) Put spring pin into No.1 pin spring pin hole using specially designed tool.



480L2TM214

3) DISASSEMBLY

※ Procedures are based on the type L1.

- (1) Clean pilot valve with kerosene.
 - ※ Put blind plugs into all ports
- (2) Fix pilot valve in a vise with copper (or lead) sheets.
- (3) Remove end of boot (23) from case (1) and take it out upwards.

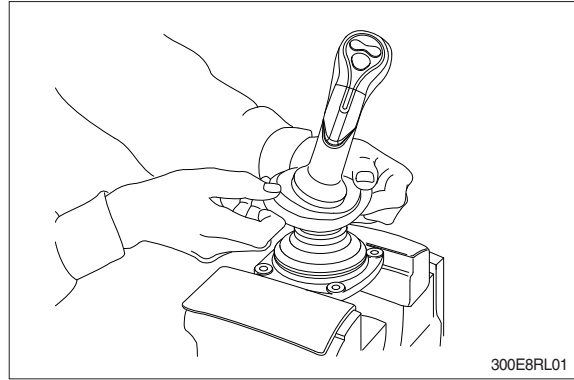

※ For valve with switch, remove cord also through hole of casing.

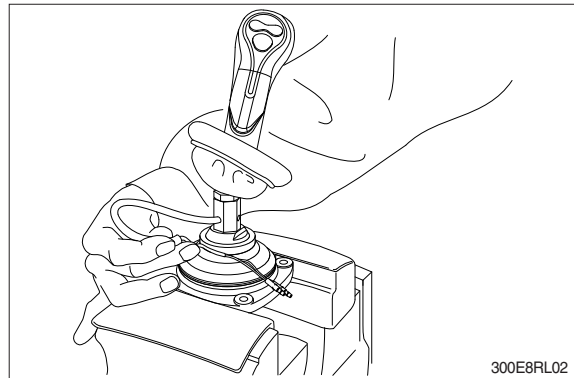

- (4) Loosen lock nut (22) and adjusting nut (17) with spanners on them respectively, and take out handle section as one body.

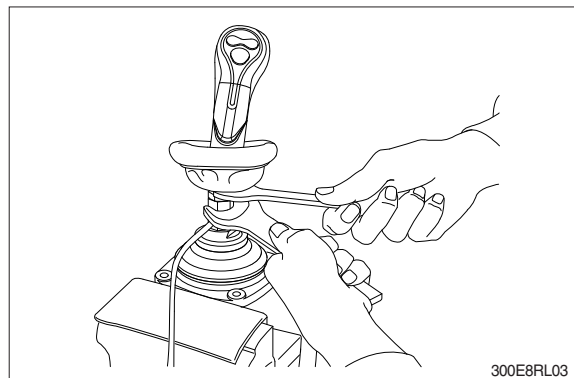

- (5) Remove the boot (14).

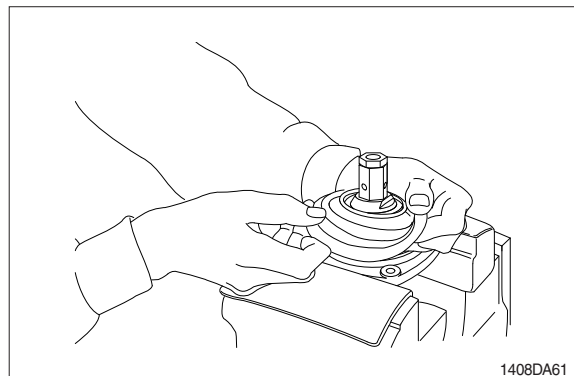

(16) Determine handle direction, tighten lock nut (22) to specified torque to fix handle.

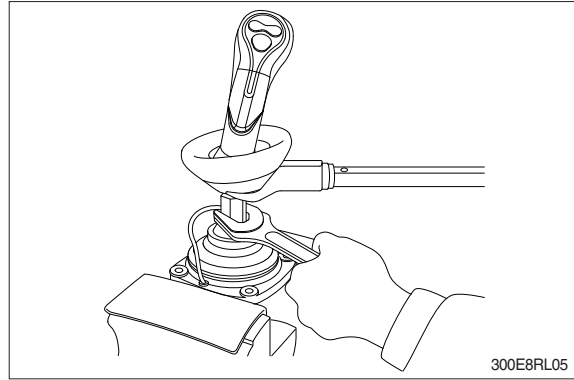

(17) Apply grease to rotating section of joint and contacting faces of disk and push rod.

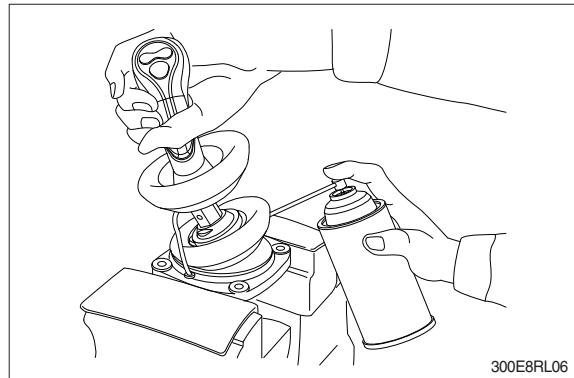

(18) Assemble lower end of bellows to casing.
(19) Inject volatile rust-preventives through all ports and then put blind plugs in ports.

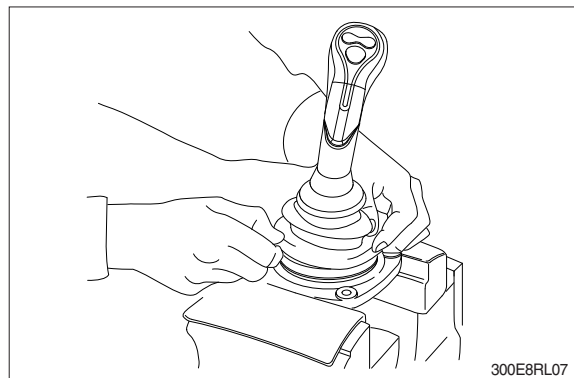

3) BOOM CYLINDER

(1) Removal

- ※ Expand the arm and bucket fully, lower the work equipment to the ground and stop the engine.
- ※ Operate the control levers and pedals several times to release the remaining pressure in the hydraulic piping.

▲ Loosen the breather slowly to release the pressure inside the hydraulic tank.

- ※ Escaping fluid under pressure can penetrate the skin causing serious injury. Fit blind plugs in the hoses after disconnecting them, to prevent dirt or dust from entering.

- ① Disconnect greasing hoses (1).
- ② Sling boom cylinder assembly.

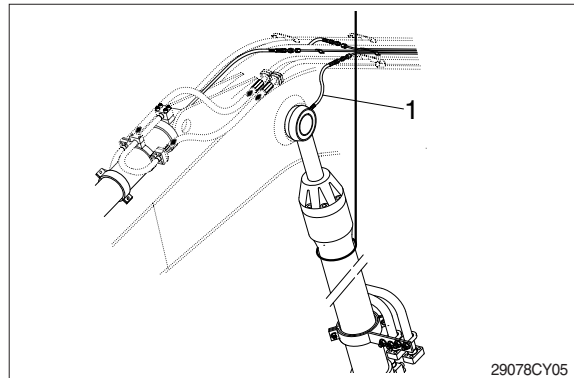

- ③ Remove bolt (4), pin stopper (5) and pull out pin (2).
- ※ Tie the rod with wire to prevent it from coming out.

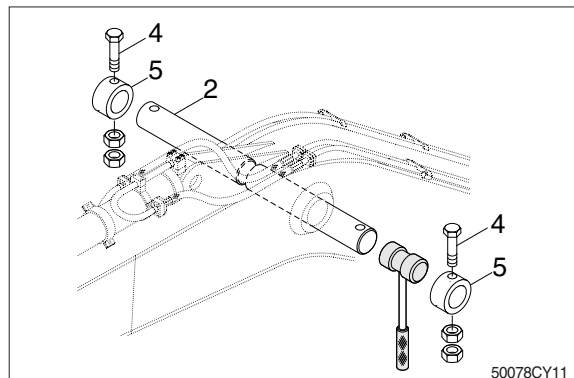

- ④ Lower the boom cylinder assembly (6) on a stand.

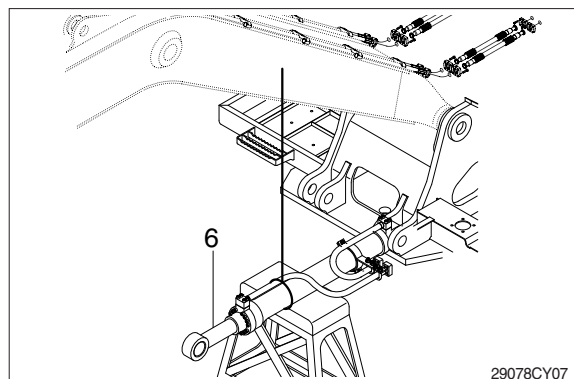

3) ASSEMBLY

(1) Assemble cylinder head assembly

※ Check for scratches or rough surfaces if found smooth with an oil stone.

- ① Coat the inner face of gland (3) with hydraulic oil.

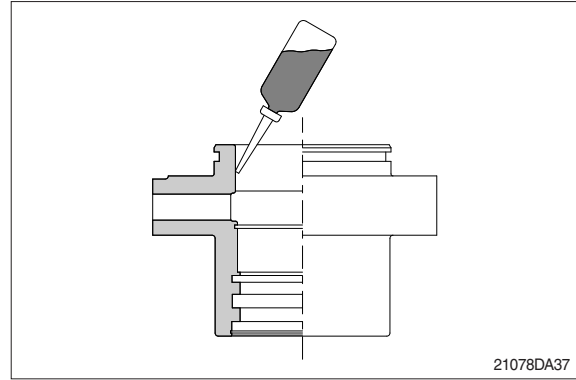

- ② Coat dust wiper (9) with grease and fit dust wiper (9) to the bottom of the hole of dust seal.

At this time, press a pad metal to the metal ring of dust seal.

- ③ Fit snap ring (10) to the stop face.

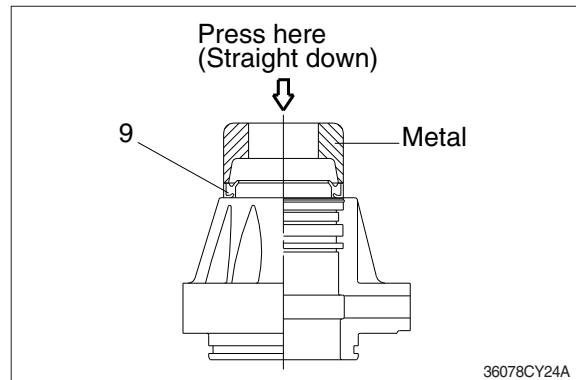

- ④ Fit back up ring (7), rod seal (6) and buffer ring (8) to corresponding grooves, in that order.

※ Coat each packing with hydraulic oil before fitting it.

※ Insert the backup ring until one side of it is inserted into groove.

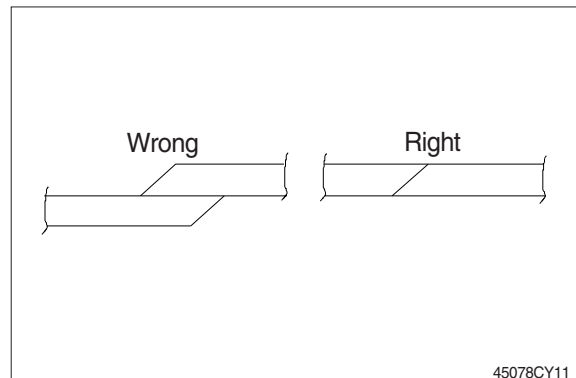

※ Rod seal (6) has its own fitting direction. Therefore, confirm it before fitting them.

※ Fitting rod seal (6) upside down may damage its lip. Therefore check the correct direction that is shown in fig.

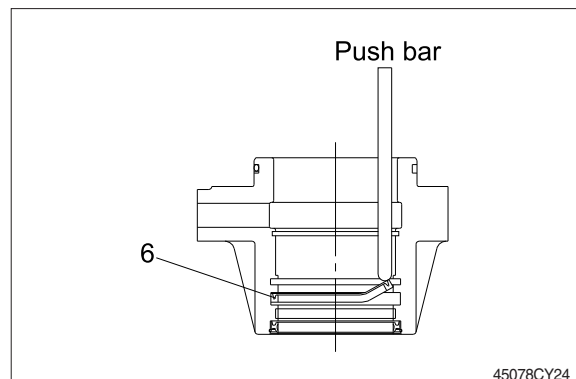

(3) Assembly

- ※ Before assembly, clean the parts.
- ※ Coat the sliding surfaces of all parts with oil.

- ① Cool up bushing (2) fully by some dry ice and press it into shell (1).

Do not press it at the normal temperature, or not knock in with a hammer even after the cooling.

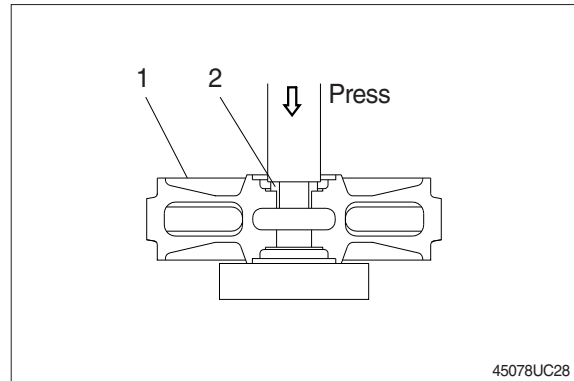

- ② Coat O-ring (4) with grease thinly, and install it to shaft (3).

- ③ Insert shaft (3) into bracket (6) and drive in the spring pin (7).

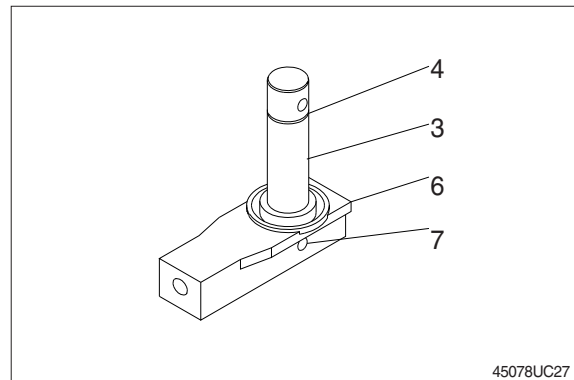

- ④ Install seal (5) to shell (1) and bracket (6).

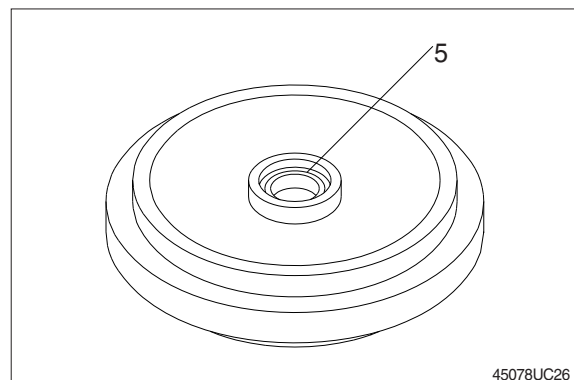

- ⑤ Install shaft (3) to shell (1).

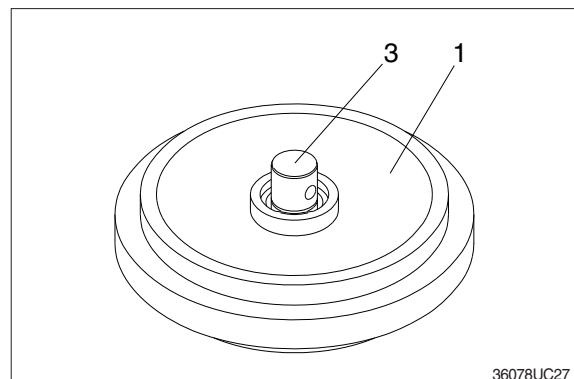

SECTION 9 COMPONENT MOUNTING TORQUE

Group 1	Introduction guide	9-1
Group 2	Engine system	9-2
Group 3	Electric system	9-4
Group 4	Hydraulic system	9-6
Group 5	Undercarriage	9-9
Group 6	Structure	9-11
Group 7	Work equipment	9-15

CLICK HERE TO **DOWNLOAD** THE COMPLETE MANUAL

- Thank you very much for reading the preview of the manual.
- You can download the complete manual from: www.heydownloads.com by clicking the link below



- Please note: If there is no response to CLICKING the link, please download this PDF first and then click on it.

CLICK HERE TO **DOWNLOAD** THE COMPLETE MANUAL