

## SECTION 1 GENERAL

Group 1 Safety Hints .....	1-1
Group 2 Specifications .....	1-10

## SECTION 2 STRUCTURE AND FUNCTION

Group 1 Pump Device .....	2-1
Group 2 Main Control Valve .....	2-20
Group 3 Swing Device .....	2-56
Group 4 Travel Device .....	2-67
Group 5 RCV Lever .....	2-81
Group 6 RCV Pedal .....	2-85

## SECTION 3 HYDRAULIC SYSTEM

Group 1 Hydraulic Circuit .....	3-1
Group 2 Main Circuit .....	3-3
Group 3 Pilot Circuit .....	3-6
Group 4 Single Operation .....	3-13
Group 5 Combined Operation .....	3-23

## SECTION 4 ELECTRICAL SYSTEM

Group 1 Component Location .....	4-1
Group 2 Electrical Circuit .....	4-3
Group 3 Electrical Component Specification .....	4-20
Group 4 Connectors .....	4-29

## SECTION 5 MECHATRONICS SYSTEM

Group 1 Outline .....	5-1
Group 2 Mode selection System .....	5-3
Group 3 Automatic Deceleration System .....	5-6
Group 4 Travel Speed Control System .....	5-7
Group 5 Automatic Warming Up Function .....	5-8
Group 6 Engine Overheat Prevention Function .....	5-9

CLICK HERE TO **DOWNLOAD** THE COMPLETE MANUAL

- Thank you very much for reading the preview of the manual.
- You can download the complete manual from: [www.heydownloads.com](http://www.heydownloads.com) by clicking the link below



- Please note: If there is no response to CLICKING the link, please download this PDF first and then click on it.

CLICK HERE TO **DOWNLOAD** THE COMPLETE MANUAL

# SECTION 1 GENERAL



Group 1 Safety Hints .....	1-1
Group 2 Specifications .....	1-10

# SPECIFICATIONS

## GROUP 2 SPECIFICATIONS

### 1. MAJOR COMPONENT

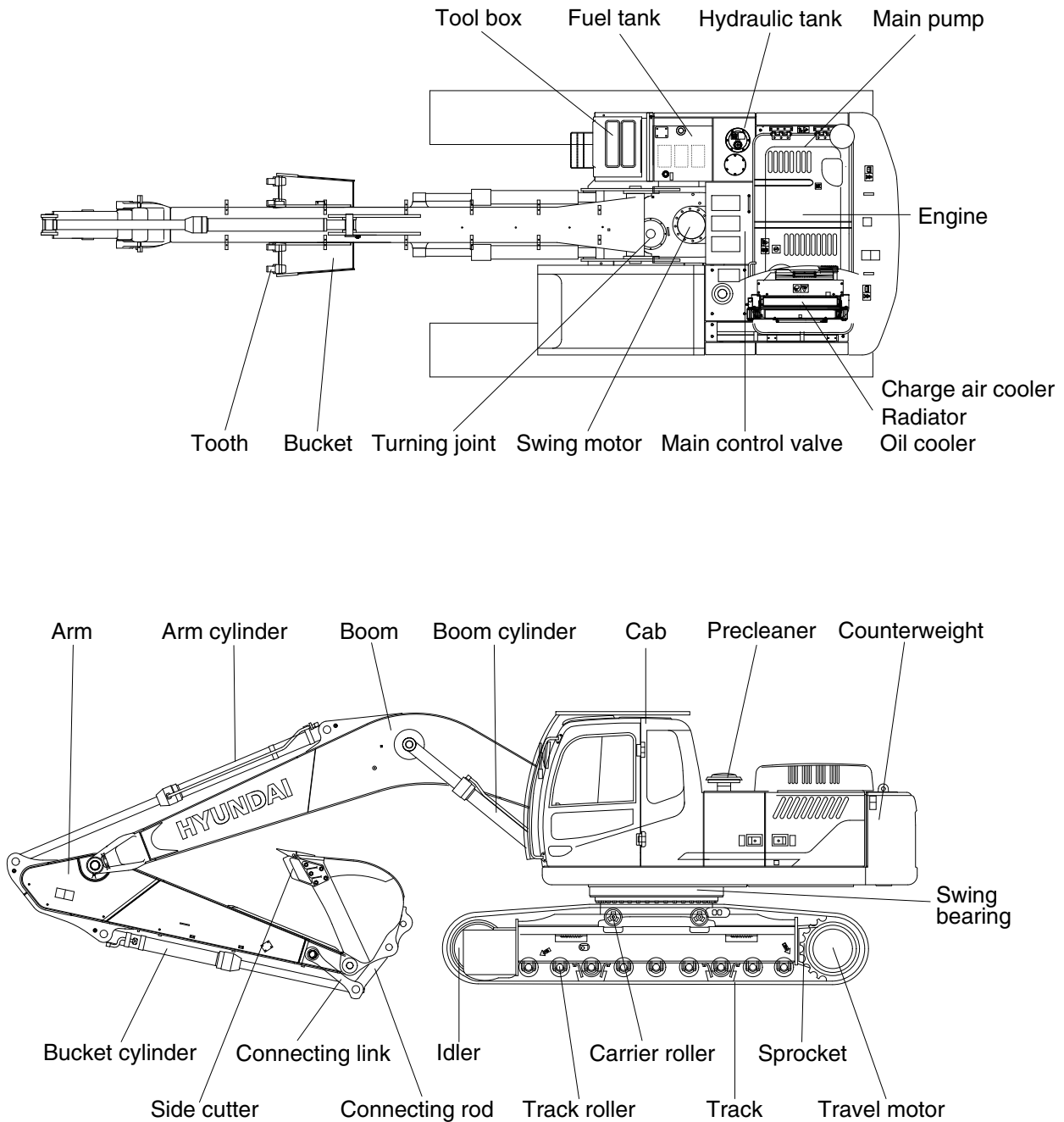

210S2SP01A

Model	Type	Boom	Arm	Counterweight	Shoe	Wheel	Dozer		Outrigger	
HX210S	MONO BOOM	Length [mm]	Length [mm]	weight [kg]	width [mm]	width [mm]	Front	Rear	Front	Rear
		5680	2920	3600	600	-	-	-	-	-



: Rating over-front



: Rating over-side or 360 degree

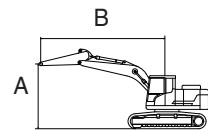

Lift-point height (A)		Lift-point radius (B)										At max. reach				
		1.5 m (4.9 ft)		3.0 m (9.8 ft)		4.5 m (14.8 ft)		6.0 m (19.7 ft)		7.5 m (24.6 ft)		Capacity		Reach		
														m (ft)		
7.5 m (24.6 ft)	kg							*4450	4450					*3370	*3370	6.26
	lb							*9810	9810					*7430	*7430	(20.5)
6.0 m (19.7 ft)	kg							*4440	*4440					*3100	3080	7.38
	lb							*9790	*9790					*6830	6790	(24.2)
4.5 m (14.8 ft)	kg							*4960	4280	4570	2960			*3020	2590	8.07
	lb							*10930	9440	10080	6530			*6660	5710	(26.5)
3.0 m (9.8 ft)	kg					*7400	6190	*5790	4030	4450	2850			*3070	2340	8.43
	lb					*16310	13650	*12760	8880	9810	6280			*6770	5160	(27.7)
1.5 m (4.9 ft)	kg					*9130	5670	6050	3790	4320	2730			*3250	2240	8.51
	lb					*20130	12500	13340	8360	9520	6020			*7170	4940	(27.9)
0.0 m (0.0 ft)	kg			*5920	*5920	9140	5390	5850	3610	4220	2640			*3590	2280	8.32
	lb			*13050	*13050	20150	11880	12900	7960	9300	5820			*7910	5030	(27.3)
-1.5 m (-4.9 ft)	kg	*6500	*6500	*10400	10130	9040	5300	5770	3530	4190	2610			3950	2470	7.84
	lb	*14330	*14330	*22930	22330	19930	11680	12720	7780	9240	5750			8710	5450	(25.7)
-3.0 m (-9.8 ft)	kg	*11120	*11120	*14170	10310	9110	5360	5800	3560					4680	2920	7.00
	lb	*24520	*24520	*31240	22730	20080	11820	12790	7850					10320	6440	(23.0)
-4.5 m (-14.8 ft)	kg			*11620	10680	*8190	5570							*6080	4080	5.65
	lb			*25620	23550	*18060	12280							*13400	8990	(18.5)

Note 1. Lifting capacity are based on ISO 10567.

- Lifting capacity of the HX series does not exceed 75% of tipping load with the machine on firm, level ground or 87% of full hydraulic capacity.
- The Lift-point is bucket pivot mounting pin on the arm (without bucket mass).
- \*Indicates load limited by hydraulic capacity.

※ Lifting capacities are based upon a standard machine conditions.

Lifting capacities will vary with different work tools, ground conditions and attachments.

The difference between the weight of a work tool attachment must be subtracted.

Consult your HD Hyundai Construction Equipment dealer regarding the lifting capacities for specific work tools and attachments.

▲ Failure to comply to the rated load can cause possible personal injury or property damage.

Make adjustments to the rated load as necessary for non-standard configurations.

## 7. UNDERCARRIAGE

### 1) TRACKS

X-leg type center frame is integrally welded with reinforced box-section track frames. The design includes dry tracks, lubricated rollers, idlers, sprockets, hydraulic track adjusters with shock absorbing springs, and assembled track-type tractor shoes with triple grousers.

### 2) TYPES OF SHOES

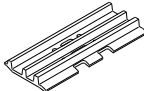
Model	Shapes		Triple grouser			
						
HX210S	Shoe width	mm (in)	600 (24)	-	-	800 (32)
	Operating weight	kg (lb)	20830 (45920)	-	-	21380 (47140)
	Ground pressure	kgf/cm <sup>2</sup> (psi)	0.48 (6.81)	-	-	0.42 (5.99)
	Overall width	mm (ft-in)	2800 (9' 2")	-	-	3000 (9' 10")
HX220S	Shoe width	mm (in)	600 (24)★	600 (24)	700 (28)	800 (32)
	Operating weight	kg (lb)	21260 (46870)	21450 (47290)	21750 (47950)	22040 (48590)
	Ground pressure	kgf/cm <sup>2</sup> (psi)	0.45 (6.45)	0.46 (6.51)	0.40 (5.56)	0.35 (5.02)
	Overall width	mm (ft-in)	2990 (9' 10")	2800 (9' 2")	3090 (10' 2")	3190 (10' 6")

★ : 8.5 T

### 3) NUMBER OF ROLLERS AND SHOES ON EACH SIDE

Item		Quantity
Carrier rollers		2 EA
Track rollers	HX210S	7 EA
	HX220S	9 EA
Track shoes	HX210S	46 EA
	HX220S	49 EA

## 2) REGULATOR (1/2)

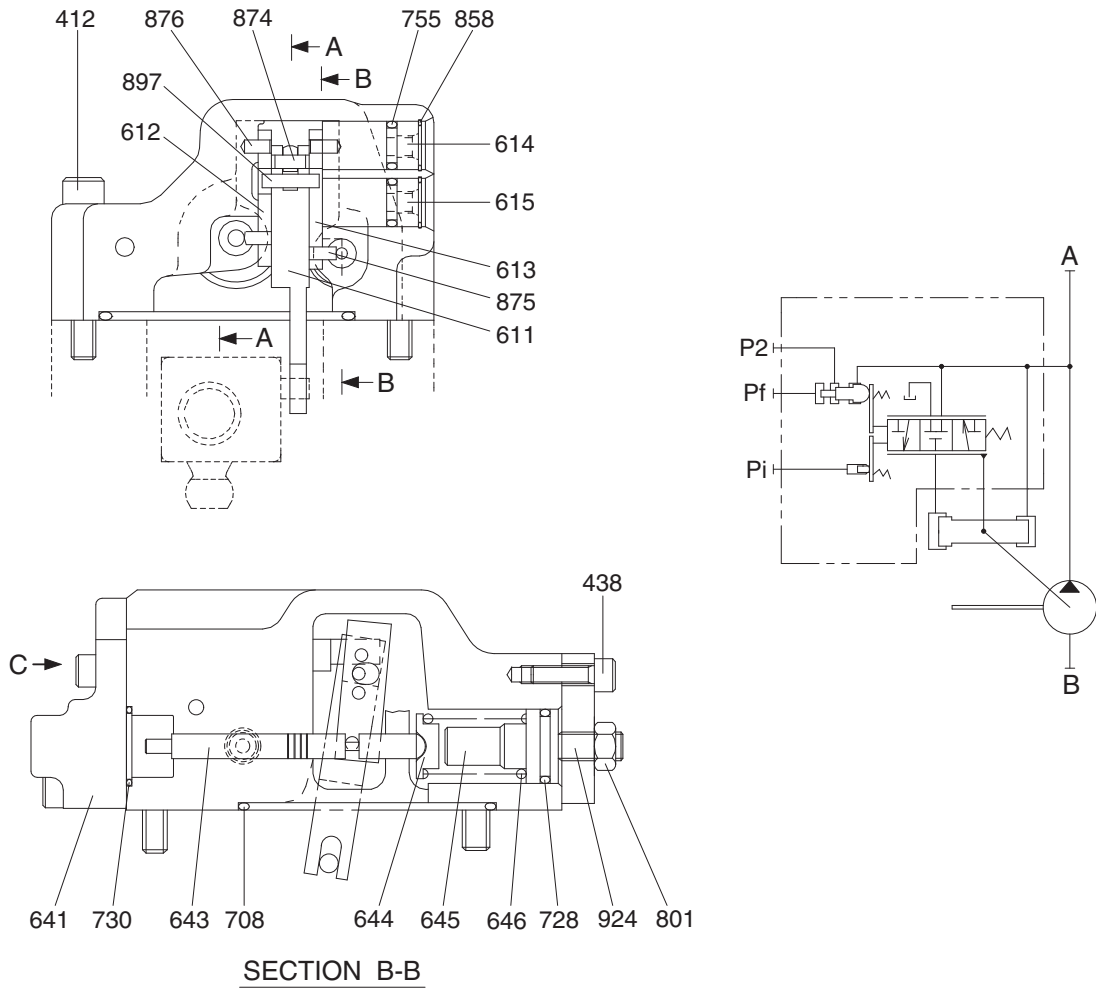

2209S2MP03

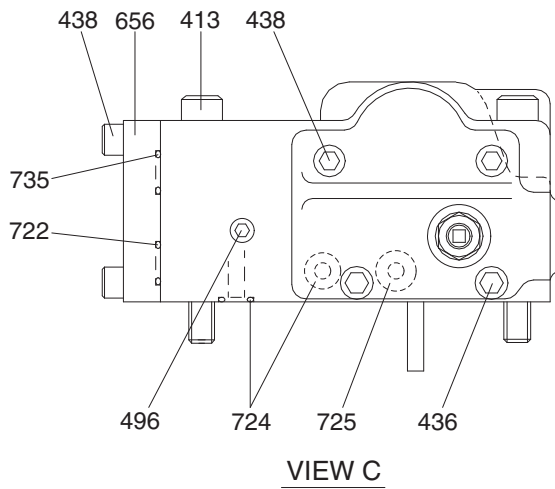

Port	Port name	Port size
A	Delivery port	3/4"
B	Suction port	2 1/2"
Pi	Pilot port	PF 1/4-15
Pf	Power shift port	-
P2	Companion delivery port	-

① Overload preventive function

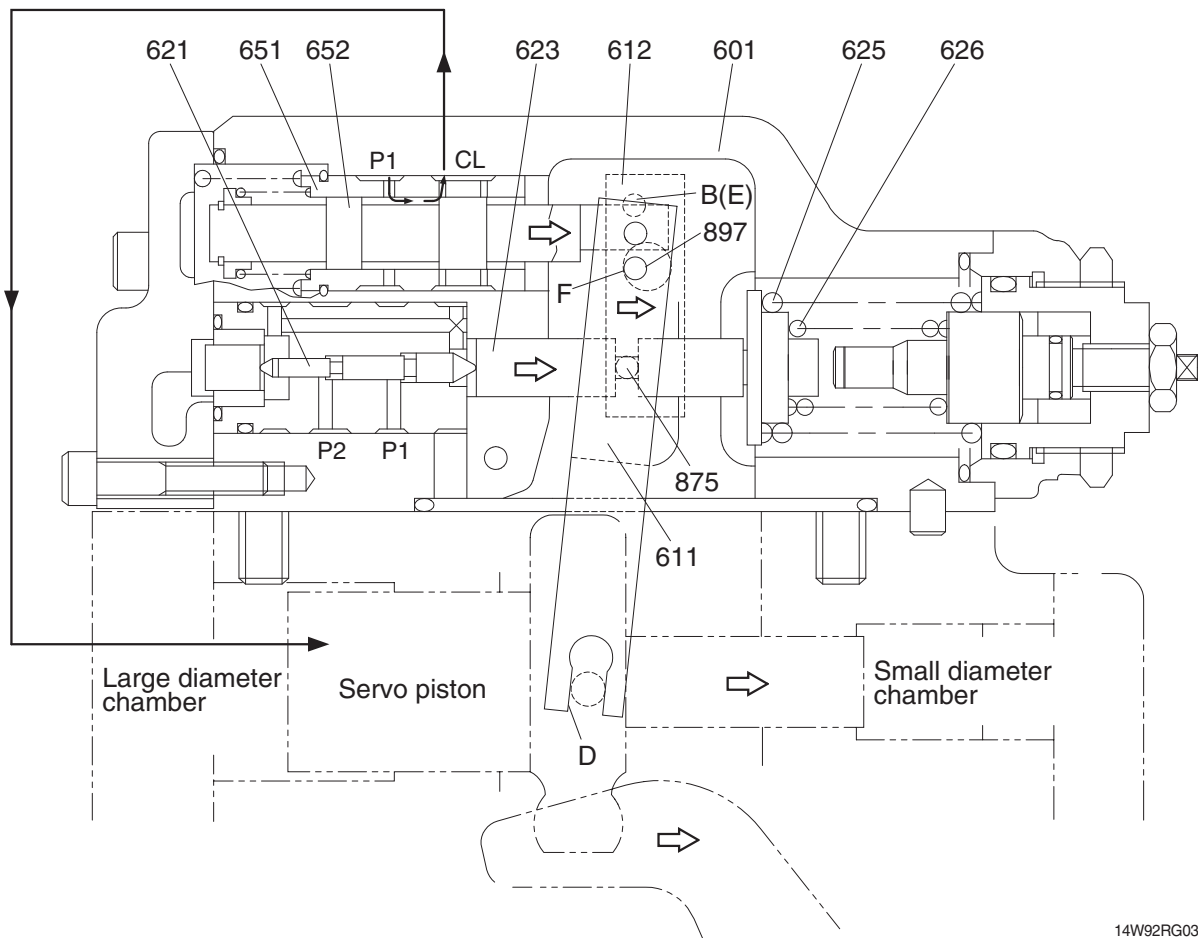

14W92RG03

When the self pump delivery pressure P1 or the companion pump delivery pressure P2 rises, it acts on the stepped part of the compensating piston (621). It presses the compensating rod (623) to the right till the force of the outer spring (625) and inner spring (626) balances with the hydraulic force. The movement of the compensating rod is transmitted to lever 1 (612) via pin (875).

Lever 1 rotates around the pin (875) (E) fixed to the casing (601).

Since the large hole section (F) of lever 1 contains a protruding pin (897) fixed to the feedback lever (611), the feedback lever rotates around the fulcrum of point D as lever 1 rotates, and then the spool (652) is shifted to the right. As the spool moves, the delivery pressure P1 is admitted to the large diameter section of the servo piston via port CL, causes the servo piston move to the right, reduces the pump delivery, flow rate, and prevents the prime mover from being overloaded. The movement of the servo piston is transmitted to the feedback lever via point D. Then the feedback lever rotates around the fulcrum of point F and the spool is shifted to the left. The spool moves till the opening between the spool (652) and sleeve (651) is closed.

## STRUCTURE (5/8)

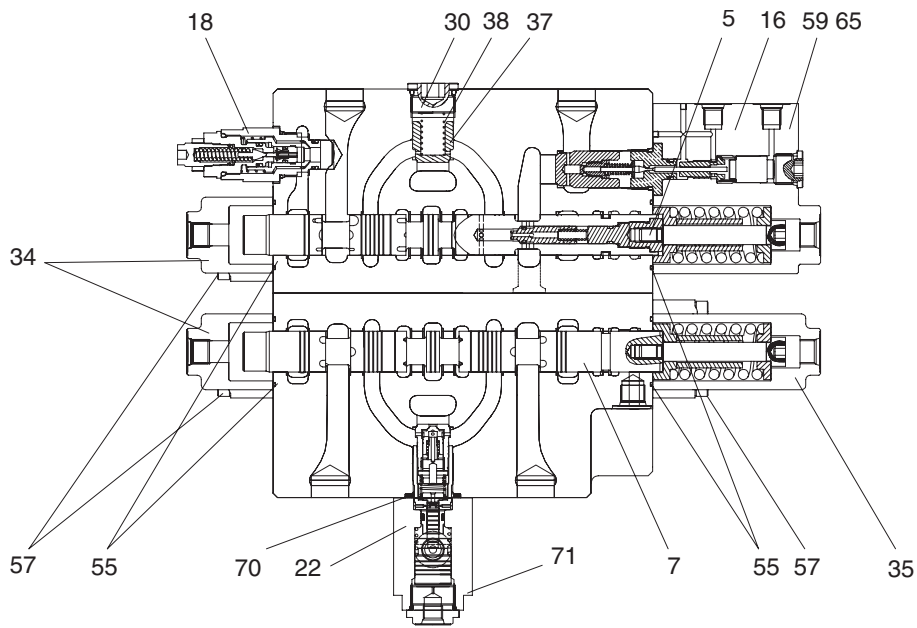

C-C' (SWING AND BOOM1)

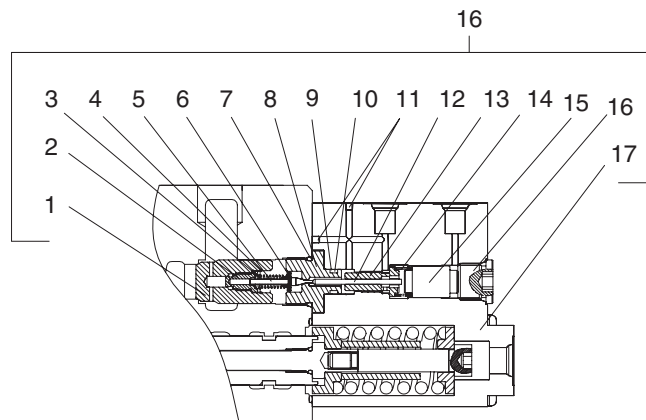

HOLDING VALVE

220S2MC06

- |                       |                          |                         |
|-----------------------|--------------------------|-------------------------|
| 5 Boom 1 spool kit    | 16-9 Back up ring        | 30 Plug                 |
| 7 Swing spool kit     | 16-10 O-ring             | 34 Pilot cover A        |
| 16 Holding valve assy | 16-11 Plug               | 35 Pilot cover B        |
| 16-1 Main poppet      | 16-12 Pilot piston       | 37 Check valve poppet 1 |
| 16-2 Restrictor       | 16-13 Piston guide       | 38 Check valve spring 1 |
| 16-3 Pilot spring     | 16-14 Spring             | 55 O-ring               |
| 16-4 C-ring           | 16-15 Main piston        | 57 Hex socket head bolt |
| 16-5 Pilot poppet     | 16-16 Plug               | 58 Hex socket head bolt |
| 16-6 Poppet guide     | 16-17 Block              | 65 Spring washer        |
| 16-7 O-ring           | 18 Overload relief valve | 70 O-ring               |
| 16-8 Poppet seat      | 22 Swing logic valve     | 71 Hex socket head bolt |

### (3) Travel straight function

This function keeps straight travel in case of simultaneous operation of other actuators (boom, arm, bucket, swing etc) during a straight travel.

In normal conditions, travel straight spool keeps neutral conditions, the pressurized oil of the P1 and P2 pumps is supplied to each passage independently.

When the attachment spool is operated under the travel operation of both sides, the pilot pressure is supplied to the spring side port of the travel straight spool and then the travel straight spool is shifted to the left direction.

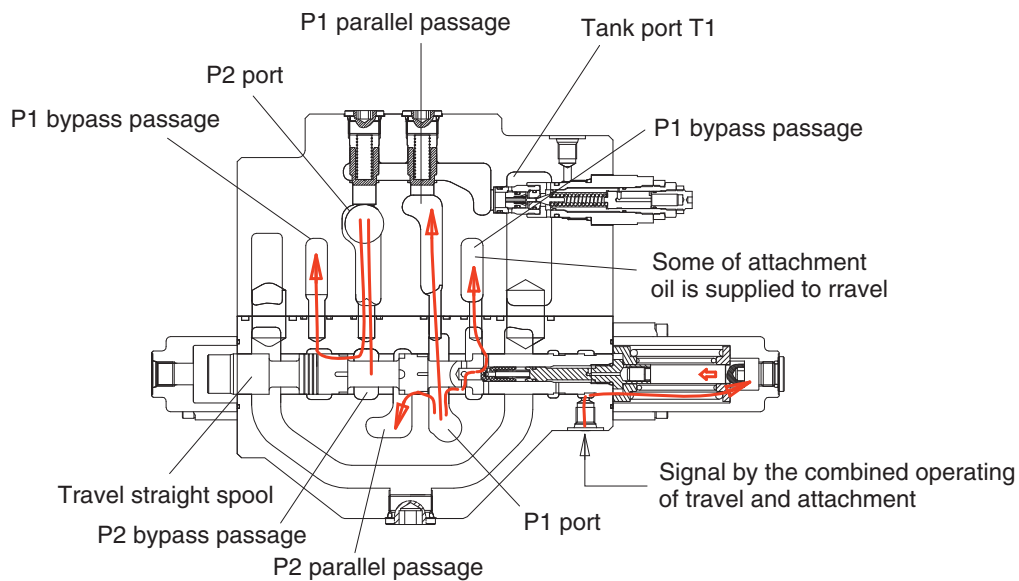

A-A' (STRAIGHT TRAVEL AND SUPPLY)

220S2MC20

After changeover of the travel straight spool, the pressurized oil discharged from the P1 pump is connected with P2 port oil and is supplied to the attachment line through both parallel passage of the P1 and P2.

Also, some of the pressurized oil open the check valve of the spool inside through side of the travel straight spool and is connected with the bypass passage of the P2 side.

On the other hand, the pressurized oil discharged from the P2 pump is connected with P1 port oil and is supplied to the travel line through both parallel passage of the P1 and P2.

Accordingly the attachment spool is operated under the travel operation of both sides, the pressurized oil discharged from P2 pump is mainly supplied to left and right travel line and the pressurized oil discharged from P1 pump is mainly supplied to attachment line.

As a result, simultaneous operation of both travel spools and attachment is not influenced to the travel operation of the both sides and the machine keeps straight travel.

## (2) Boom priority function

This function is used to speed up of the boom by reducing the swing speed when the swing operation with boom operation simultaneously.

The boom priority signal is supplied the pilot port and the poppet of the swing logic valve is closed and then the pressurized oil from P2 port is reduced by the oil leaking through the orifice.

As a result, the swing speed is slowed.

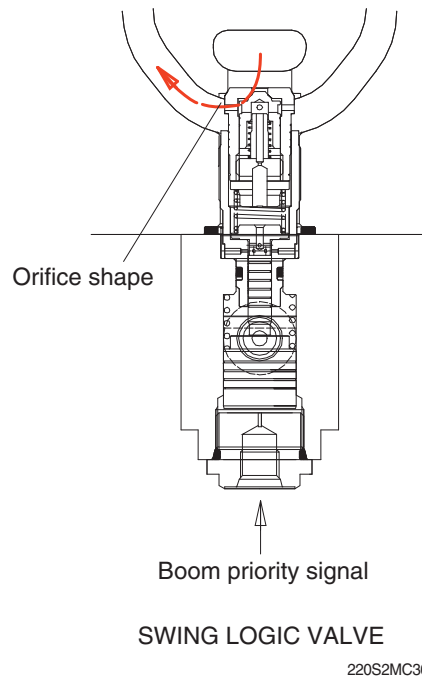

## 12) OPERATION OF PORT RELIEF VALVE

### (1) Function as relief valve

- ① The pressurized oil passes through the internal passage of the piston A, fitted in the main poppet and the orifice A and is filled up in the chamber A of the inside and seats the main poppet against socket and socket against the housing securely.

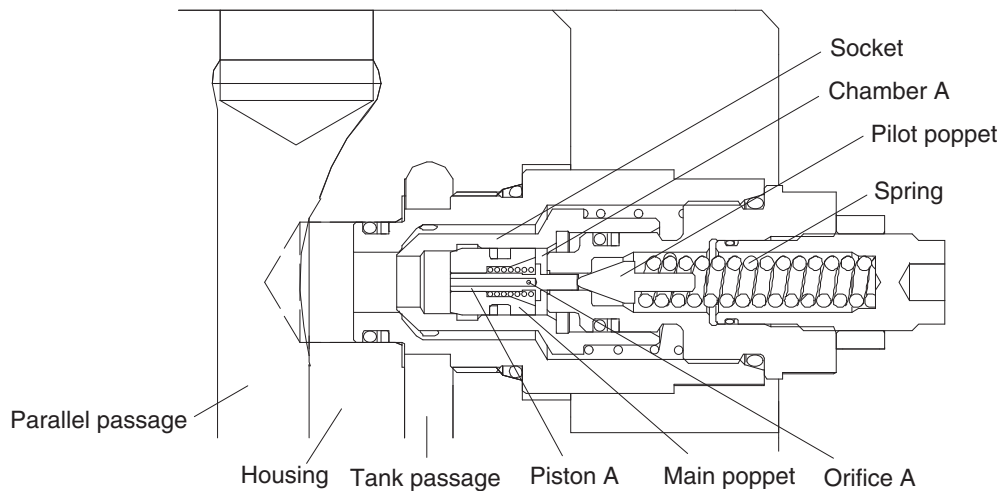

PORT RELIEF VALVE

220S2MC43

- ② When the pressurized oil from the actuators becomes equal to the set pressure of the spring, the hydraulic oil apply to the pilot poppet and pushes the pilot poppet to the right direction and flows to tank passage through the piston A internal passage, orifice A, chamber A, periphery orifice B and the hole E.

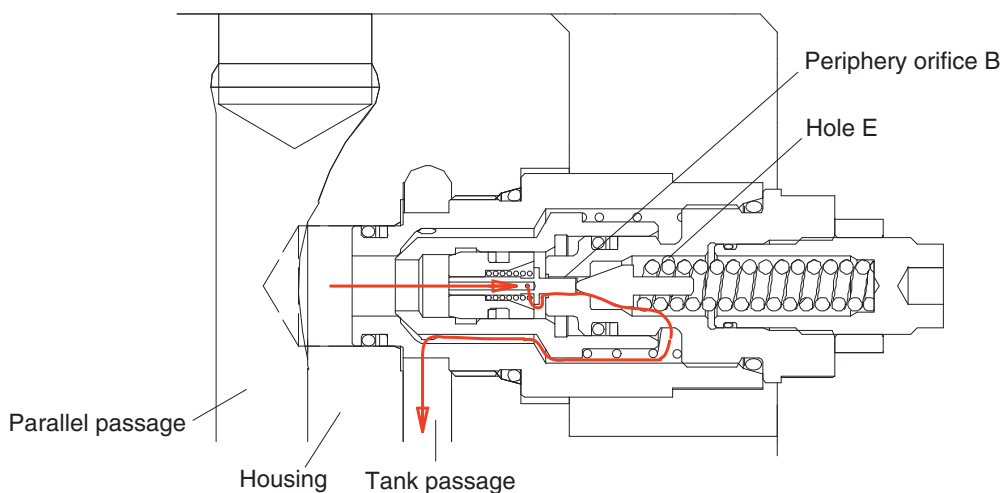

OPERATION 1 OF PORT RELIEF VALVE

220S2MC44

## 4) BRAKE SYSTEM

### (1) Control valve swing brake system

This is the brake system to stop the swing motion of the excavator during operation.

In this system, the hydraulic circuit is throttled by the swing control valve, and the resistance created by this throttling works as a brake force to slow down the swing motion.

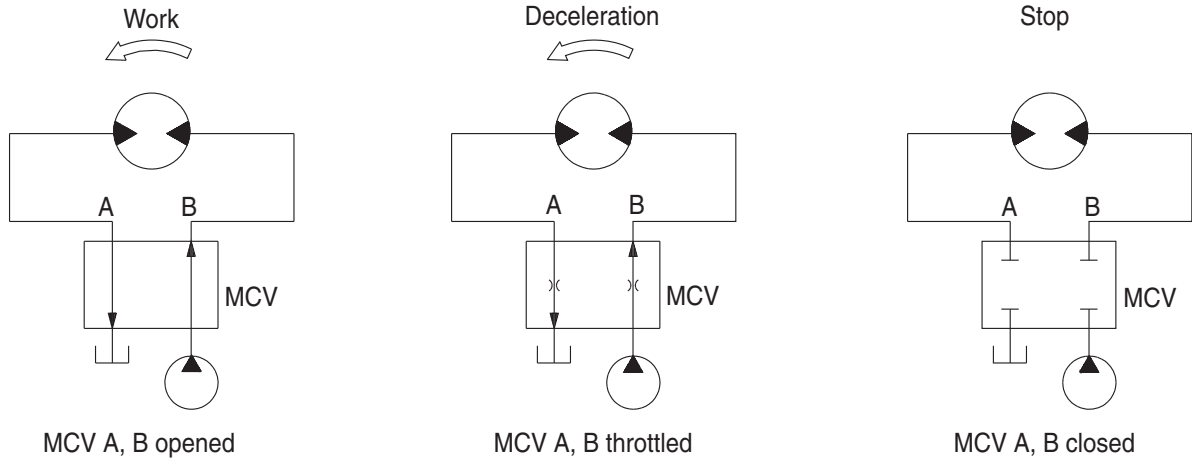

2-48(1)

### (2) Mechanical swing parking brake system

This is function as a parking brake only when all of the RCV lever (except travel pedal) are not operated.

#### ① Brake assembly

Circumferential rotation of separate plate (14) is constrained by the groove located at casing (1). When housing is pressed down by brake spring (16) through friction plate (13), separate plate (14) and parking piston (15), friction force occurs there.

Cylinder block (8) is constrained by this friction force and brake acts, while brake releases when hydraulic force exceeds spring force.

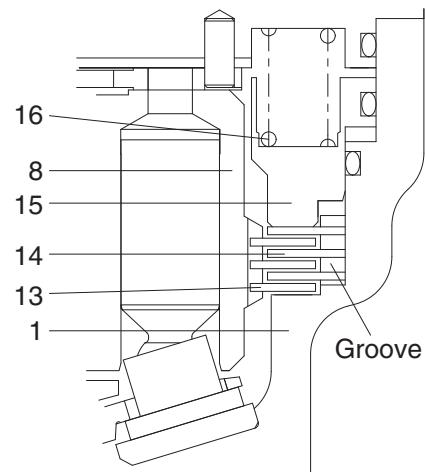

2209A2SM35

1	Casing	14	Separate plate
8	Cylinder block	15	Parking piston
13	Friction plate	16	Brake spring

## (2) Operation

Two pieces of overload valves are located at cross-over position in the counterbalance circuit of brake valve and have the following functions :

- ① When hydraulic motor starts, keep the driving pressure below predetermined value and while accelerating, bypasses surplus oil to return line.
- ② When stopping the motor, keep the brake pressure, that develops on the outlet side of motor, under the predetermined value to stop the inertial force.
- ③ To accelerate sharply while starting, and to mitigate the braking shock while stopping. For these purposes, the developed pressure is kept comparatively low for a short period, then keep the line pressure as normal value. While the pressure is low, meshing of reduction gears, crawler and sprocket etc. can be smoothly done and the shock are absorbed.

When starting, "A" port pressure of overload valve increases, this pressure is applied to the effective diameter of poppet (42-10) which seats on the poppet seat (42-11) and, at the same time, is delivered, via small hole, to the spring seat (42-5) located inside the sleeve (42-6) and the seat bore pressure increases up to "A" port pressure. The poppet (42-10) opposes to spring (42-4) by the force of the pressure exerted on the area difference between poppet seat's effective diameter and spring seat bore and keep the predetermined pressure.

When hydraulically braking, the piston (42-7) is at the left position by the driving pressure, and when "A" port pressure increases, the pressure is applied also to the piston (42-7) through the small hole in the poppet (42-10) and piston (42-7) moves rightward until it touches the stopper in rear cover. In this while, the poppet (42-10) maintains "A" port pressure at comparatively low against the spring (42-4) force and exhaust oil to "B" port side. After the piston reached to the plug, the valve acts the same as at starting.

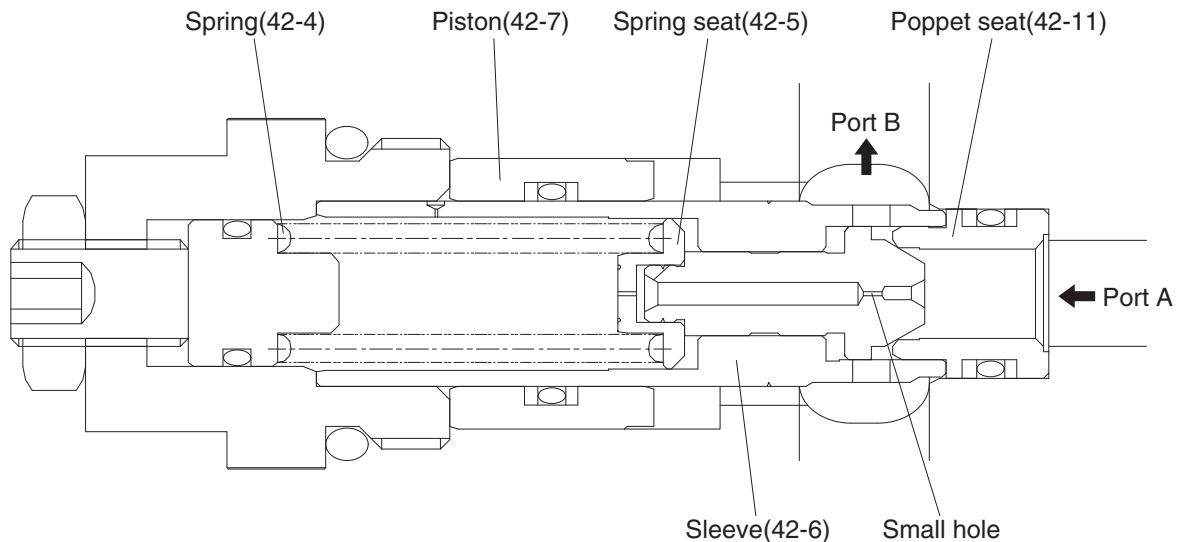

25092TM27

## 2. FUNCTIONS

### 1) FUNDAMENTAL FUNCTIONS

The pilot valve is a valve that controls the spool stroke, direction, etc of a main control valve. This function is carried out by providing the spring at one end of the main control valve spool and applying the output pressure (secondary pressure) of the pilot valve to the other end.

For this function to be carried out satisfactorily, the pilot valve is composed of the following elements.

- (1) Inlet port (P) where oil is supplied from hydraulic pump.
- (2) Output ports (1, 2, 3 & 4) to apply pressure supplied from inlet port to ends of control valve spools.
- (3) Tank port (T) necessary to control the above output pressure.
- (4) Spool to connect output port to inlet port or tank port.
- (5) Mechanical means to control output pressure, including springs that work on the above spools.

### 2) FUNCTIONS OF MAJOR SECTIONS

**Item numbers are based on the type M2.**

The functions of the spool (3) are to receive the supply oil pressure from the hydraulic pump at its port P, and to change over oil paths to determine whether the pressure oil of port P is led to output ports 1, 2, 3 & 4 or the output port pressure oil to tank port T.

The spring (5) works on this spool to determine the output pressure.

The change the deflection of this spring, the push rod (9) is inserted and can slide in the plug (8).

For the purpose of changing the displacement of the push rod through the swash plate (16) and adjusting nut (17) are provided the handle assy (20) that can be tilted in any direction around the fulcrum of the universal joint (15) center.

The spring (7) works on the case (1) and spring seat (6) and tries to return the push rod (9) to the zero-displacement position irrespective of the output pressure, securing its resetting to the center position.

This also has the effect of a reaction spring to give appropriate control feeling to the operator.

## SECTION 3 HYDRAULIC SYSTEM

Group 1 Hydraulic Circuit .....	3-1
Group 2 Main Circuit .....	3-3
Group 3 Pilot Circuit .....	3-6
Group 4 Single Operation .....	3-13
Group 5 Combined Operation .....	3-23

## 4. TRAVEL SPEED CONTROL SYSTEM

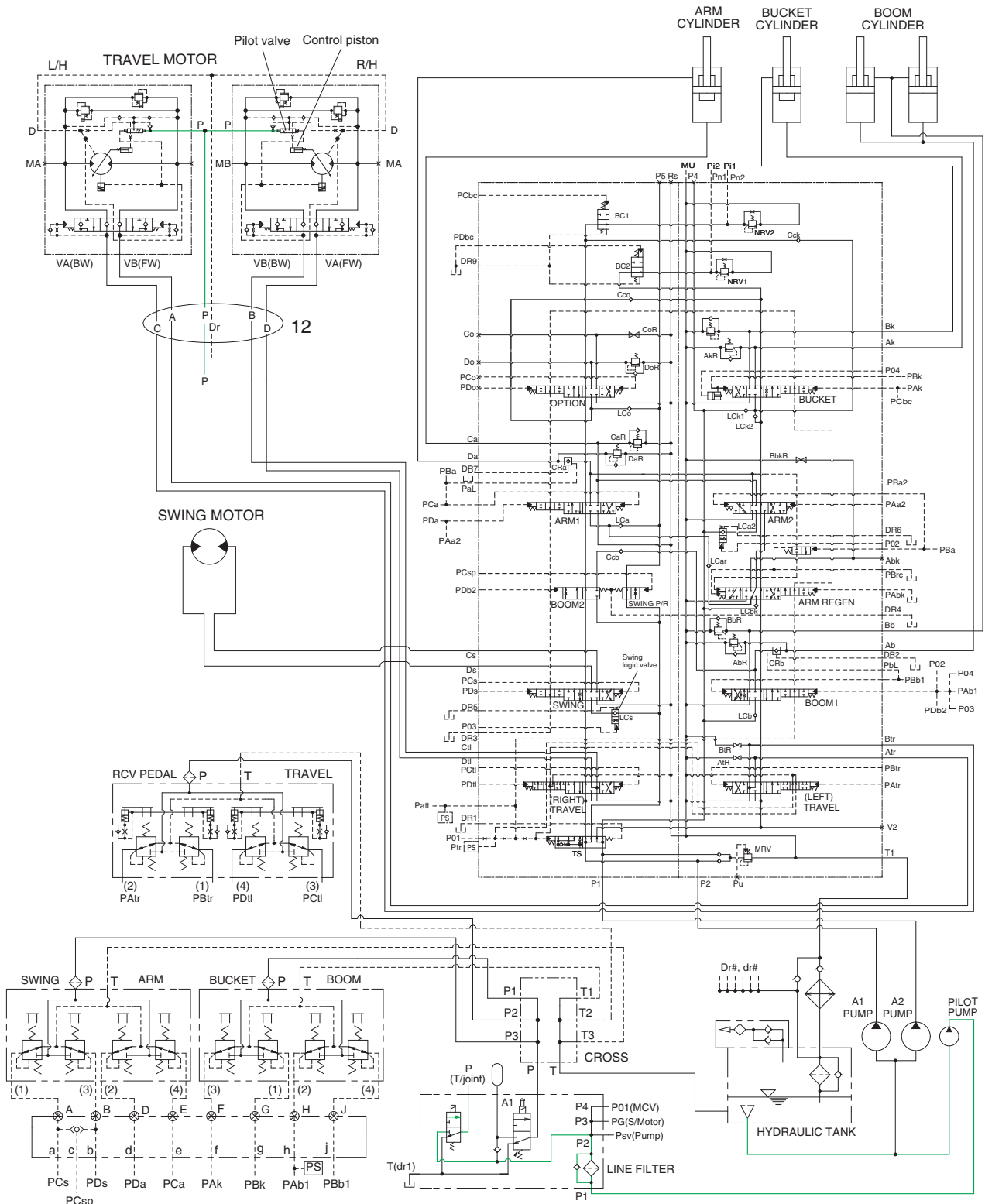

When the travel speed switch is pushed, the travel speed solenoid valve is actuated and the discharged oil from the pilot pump flows to the P port of pilot valve in the travel motors. As a result, the control piston is pushed by the main oil flow, thus the displacement is minimized. When the travel speed switch is pushed once more, the travel speed solenoid valve is return to original position by the force of spring, the hydraulic oil of P port returns to the hydraulic tank. As a result, the control piston is returned by the main oil flow, thus the displacement is maximized.

## SWING CIRCUIT OPERATION

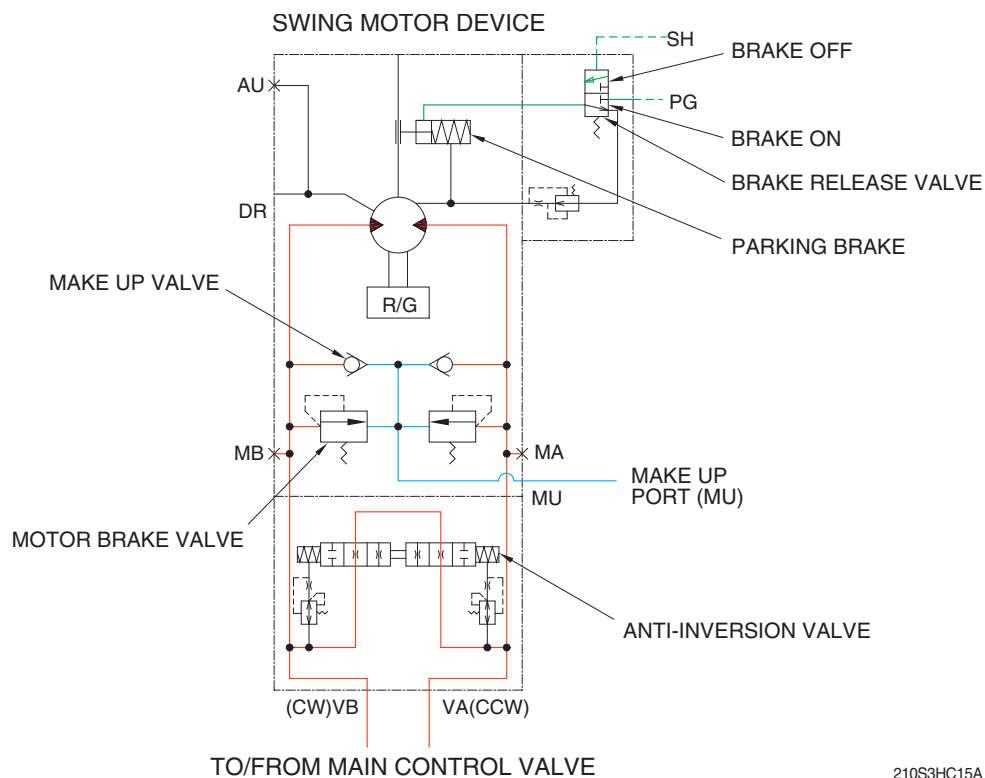

### 1) MOTOR BRAKE VALVE

Motor brake valve for the swing motor limits to cushion the starting and stopping pressure of swing operation and controls the swing motor operating pressure to 240 kgf/cm<sup>2</sup> (3414 psi).

### 2) MAKE UP VALVE

The make up valves prevent cavitation by supplying return oil to the vacuum side of the motor.

### 3) PARKING BRAKE

This is function as a parking brake only when all of the RCV lever (except travel pedal) are not operated.

#### PARKING BRAKE "OFF" OPERATION

The parking brake is released by the pilot pressure oil from the pilot pump.

When the RCV lever placed in the operating position, the pilot oil flows into SH port through the MCV. This pressure transferred to the brake release valve and the brake release valve is change over. Then the pilot oil pressure PG lift the brake piston and release the parking brake.

#### PARKING BRAKE "ON" OPERATION

When all of the RCV lever placed in the neutral position, the pressure of the pilot oil passage down. Then the brake release valve returned to the neutral position and the oil is returned from the brake piston to the tank. And the brake is set to "ON".

### 4) ANTI-INVERSION VALVE

This anti-inversion valve absorbs shocks produced as swing motion stops and reduced oscillation cause by swing motion.

## 8. COMBINED BUCKET AND TRAVEL OPERATION

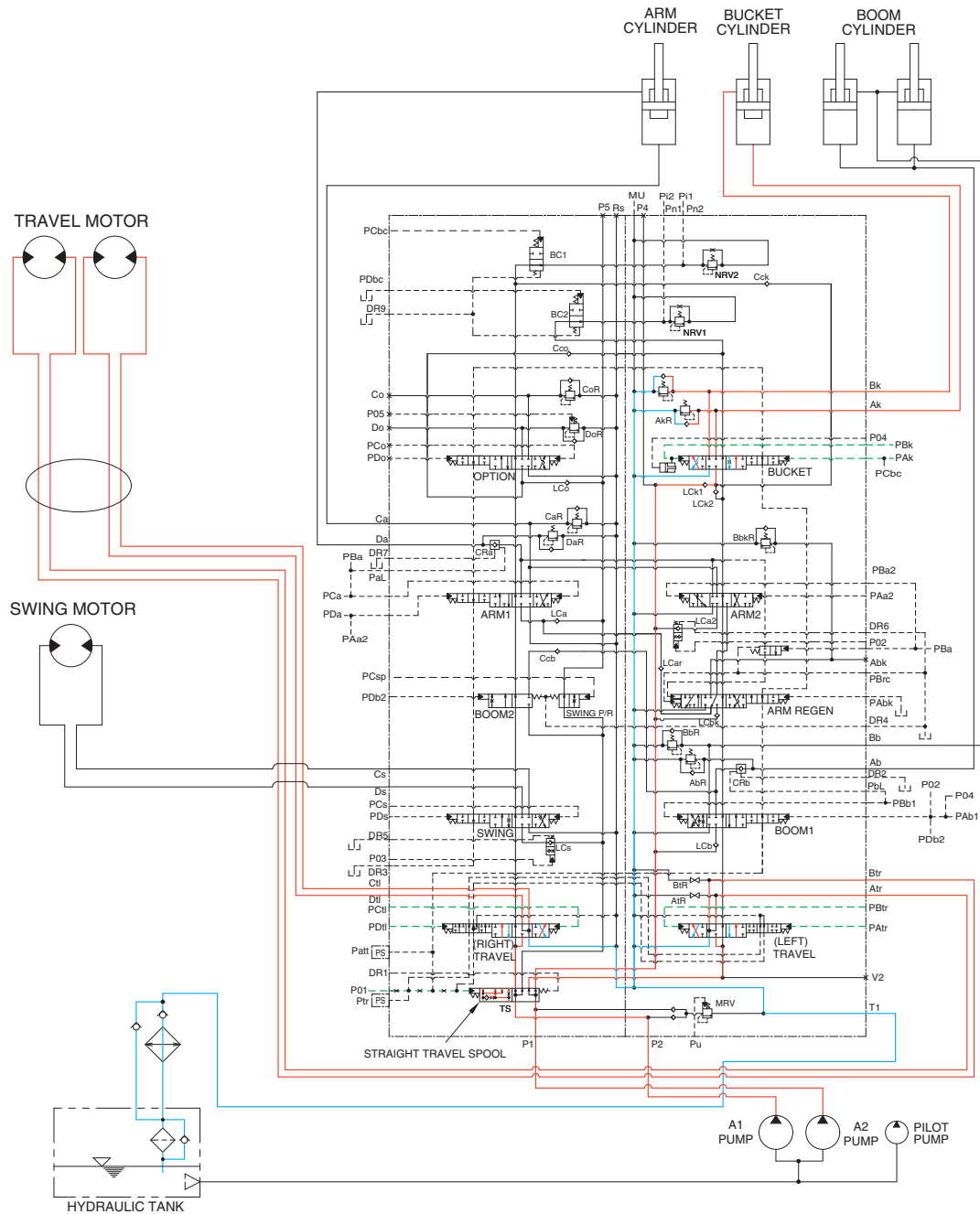

220S3HC24

When the bucket and travel functions are operated, simultaneously the bucket spool and travel spools in the main control valve are moved to the functional position by the pilot oil pressure from the remote control valve, and the straight travel spool is pushed to the right by the oil pressure from pilot pump. The oil from the A1 pump flows into the travel motors through the RH travel spool of the left control valve and the LH travel spool of the right control valve via the straight travel spool of the control valve.

The oil from the A2 pump flows into the bucket cylinder through the bucket spool via the confluence oil passage. When the pressure of the travel motors is lower than the pressure of the bucket cylinder, some oil from the A2 pump flows into the travel motors through the check valve and orifice in the straight travel spool. This prevents the rapid slowdown of the travel.

The bucket is operated and the machine travels straight.

## 2. STARTING CIRCUIT

### 1) OPERATING FLOW

Battery(+) terminal → Battery relay [CR-1] → Fusible link [CS-60] → Master switch [CS-74A]  
 → Fuse box [No.1] → Master switch [CS-74B] → I/conn [CN-8 (12)] → Start key [CS-2 (1)]

#### (1) When start key switch is in ON position

→ Start switch ON [CS-2 (2)] → I/conn [CN-8 (11)] → Battery relay [CR-1]  
 → Battery relay operating (All power is supplied with the electric component)  
 → Start switch ON [CS-2 (3)] → I/conn [CN-8 (10)] → GPS connector [CN-125 (2) → (4)]  
 → Power relay [CR-35 (86) → (87)] → Fuse box [No.12]  
 → I/conn [CN-2 (4)] → Fuel cut-off [CN-79 (2)]

#### (2) When start key switch is in START position

Start switch START [CS-2 (5)] → I/conn [CN-8 (9)] → Safety relay [CR-5 (86) → (87)]  
 → I/conn [CN-3 (8)] → Start relay [CR-23 (2)] → Start motor operating  
 → I/conn [CN-2 (3)] → Fuel cut off [CN-79 (1)]

### 2) CHECK POINT

Engine	Start switch	Check point	Voltage
OPERATING	START	① - GND(Battery) ② - GND(Start key) ③ - GND(Battery relay M4) ④ - GND(Starter B <sup>+</sup> ) ⑤ - GND(Starter M) ⑥ - GND(Start relay) ⑦ - GND(Battery relay M8)	20~25V

※ GND : Ground

# CONTROLLER CIRCUIT

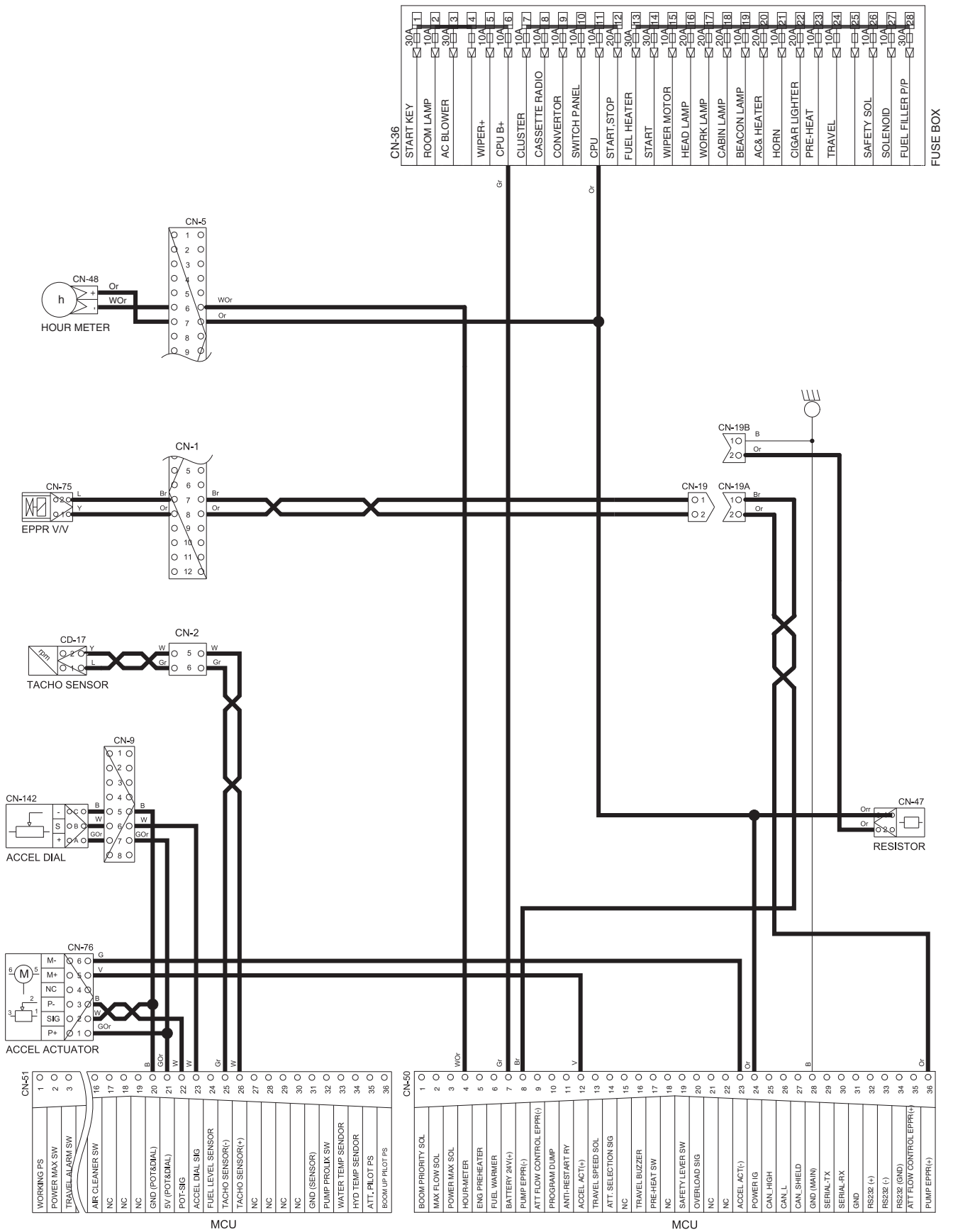

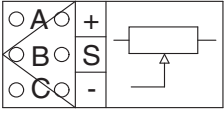
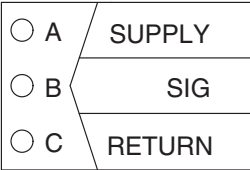
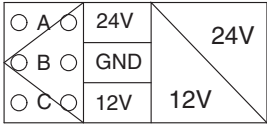
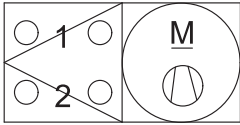
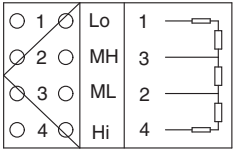
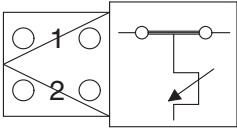
Part name	Symbol	Specification	Check
Accel dial	 <p>CN-142</p>	-	※ Check resistance Normal : About 5k $\Omega$ (For terminal A-C) ※ Check valtage Normal : About 5V (For terminal A-C) : 2 ~ 4.5V (For terminal C-B)
Pressure sensor	 <p>CD-32 CD-43 CD-69 CD-42 CD-44</p>	8~30 V	※ Check contact Normal : 0.1 $\Omega$
DC/DC Converter	 <p>CN-138</p>	12V 3A	24V(A-B) 12V(B-C)
Blower motor		24V 9.5A	※ Check resistance 2.5 $\Omega$ (For terminal 1-2)
Aircon resistor		-	※ Check resistance 1.12 $\Omega$ (For terminal 4-2) 2.07 $\Omega$ (For terminal 2-3) 3.17 $\Omega$ (For terminal 3-1)
Duct sensor (Switch)		1 $^{\circ}$ C OFF 4 $^{\circ}$ C ON	※ Check resistance : 0 $\Omega$ (For terminal 1-2, the atmosphere temp : over 4 $^{\circ}$ C)

#### 4) CN TYPE CONNECTOR

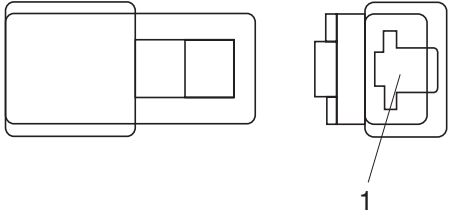
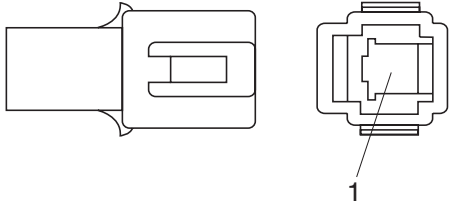
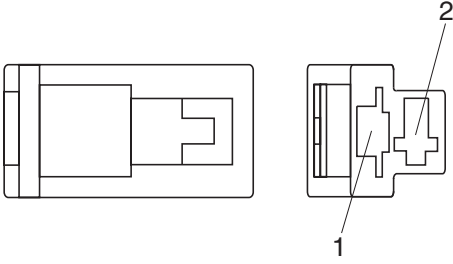
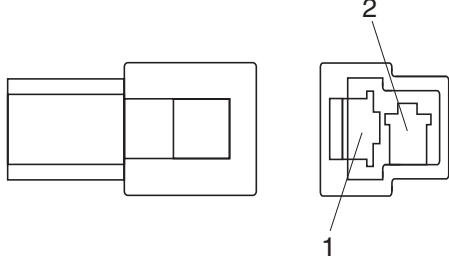
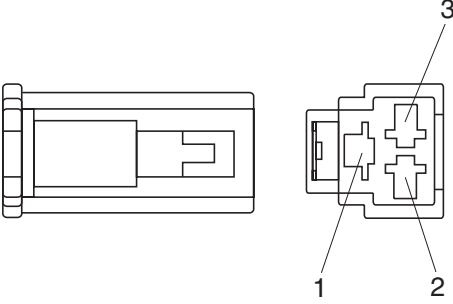
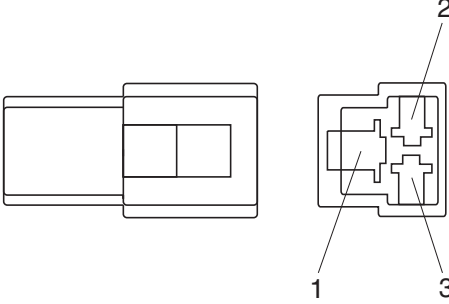
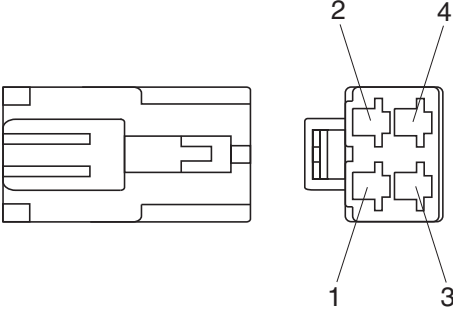
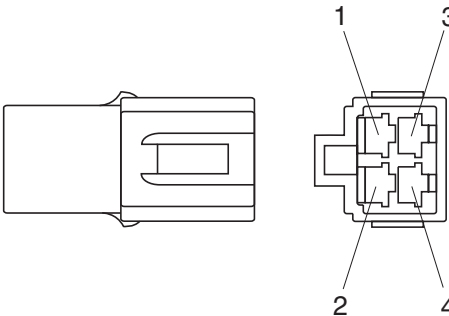
No. of pin	Receptacle connector(Female)	Plug connector(Male)
1	 <p style="text-align: center;">S810-001202</p>	 <p style="text-align: center;">S810-101202</p>
2	 <p style="text-align: center;">S810-002202</p>	 <p style="text-align: center;">S810-102202</p>
3	 <p style="text-align: center;">S810-003202</p>	 <p style="text-align: center;">S810-103202</p>
4	 <p style="text-align: center;">S810-004202</p>	 <p style="text-align: center;">S810-104202</p>

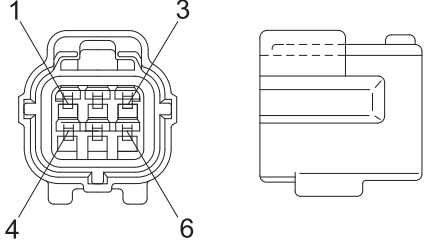
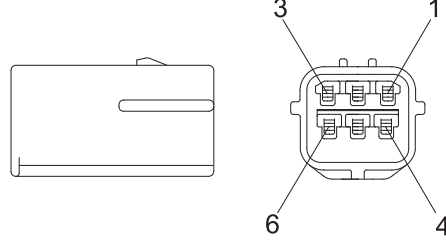
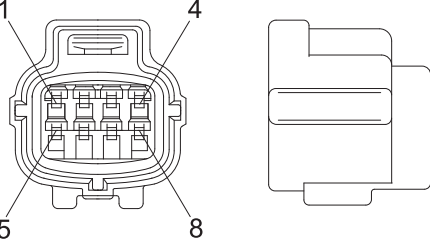
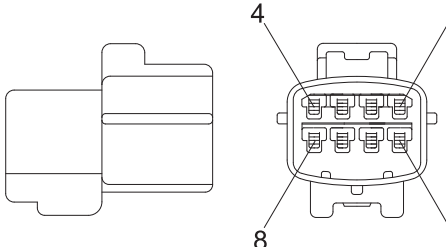
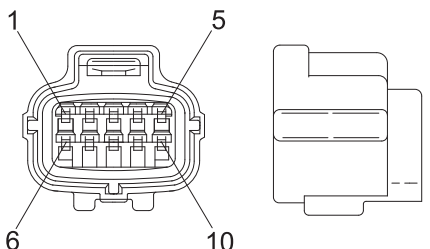
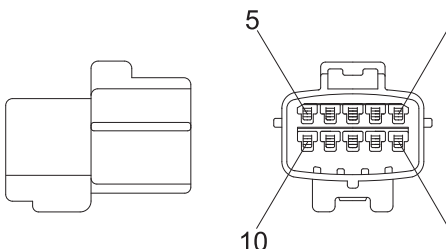
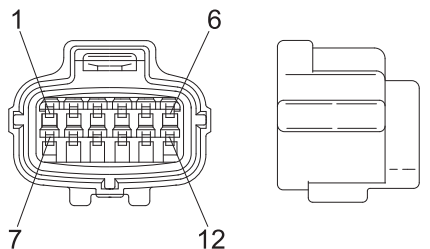
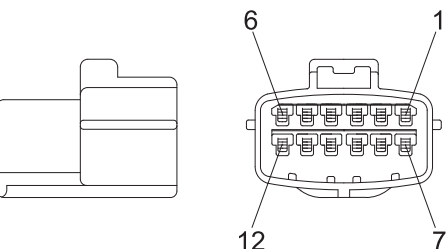
No. of pin	Receptacle connector(Female)	Plug connector(Male)
6	 <p style="text-align: center;">S816-006002</p>	 <p style="text-align: center;">S816-106002</p>
8	 <p style="text-align: center;">S816-008002</p>	 <p style="text-align: center;">S816-108002</p>
10	 <p style="text-align: center;">S816-010002</p>	 <p style="text-align: center;">S816-110002</p>
12	 <p style="text-align: center;">S816-012002</p>	 <p style="text-align: center;">S816-112002</p>

## GROUP 5 AUTOMATIC WARMING UP FUNCTION

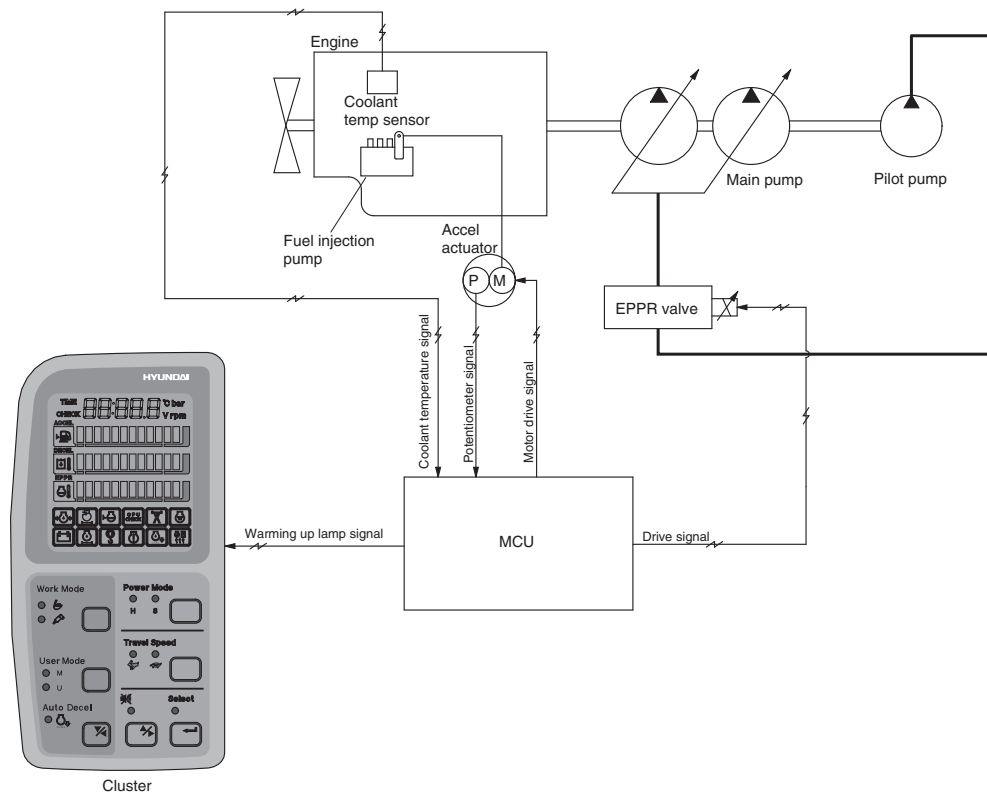

210S5MS08

1. The MCU reads engine coolant temperature through the temperature sensor, and if the coolant temperature is less than 30 °C, it increases the engine speed from key start rpm to 1250rpm. At this time the mode does not change.
2. In case of the coolant temperature increases up to 30 °C, the engine speed is decreased to key start speed. And if an operator changes mode set during the warming up function, the MCU cancels the automatic warming up function.

### 3. LOGIC TABLE

Description	Condition	Function
Actuated	<ul style="list-style-type: none"> <li>- Coolant temperature : Less than 30 °C (After engine run)</li> <li>- Accel dial position is under <b>3</b></li> </ul>	<ul style="list-style-type: none"> <li>- Mode : Default (<b>S</b> mode)</li> <li>- Warming up time : 10 minutes (Max)</li> <li>- Warming up pilot lamp : ON</li> </ul>
Canceled	<ul style="list-style-type: none"> <li>- Coolant temperature : Above 30 °C</li> <li>- Warming up time : Above 10 minutes</li> <li>- Changed mode set by operator</li> <li>- Increase engine speed by rotating accel dial clockwise</li> <li>※ If any of the above conditions is applicable, the automatic warming up function is canceled</li> </ul>	<ul style="list-style-type: none"> <li>- Default mode</li> <li>- Changed mode</li> <li>- Warming up pilot lamp : OFF</li> </ul>

## 5. MCU

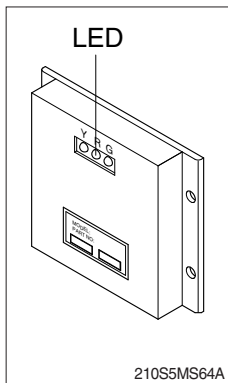

(1) To match the engine torque with the pump absorption torque, MCU varies EPPR valve output pressure, which control pump discharge amount whenever feedbacked engine speed drops under the reference rpm of each mode set.

(2) Three LED lamps on the MCU display as below.

LED lamp	Trouble	Service
G is turned ON	Normal	-
G and R are turned ON	Trouble on MCU or ROM	· Change the MCU
G and Y are turned ON	Trouble on serial communication line	· Check if serial communication lines between MCU and cluster are disconnected
Three LED are turned OFF	Trouble on MCU power	· Check if the input power wire (24V, GND) of MCU is disconnected · Check the fuse

G : green,      R : red,      Y : yellow

CLICK HERE TO **DOWNLOAD** THE COMPLETE MANUAL

- Thank you very much for reading the preview of the manual.
- You can download the complete manual from: [www.heydownloads.com](http://www.heydownloads.com) by clicking the link below



- Please note: If there is no response to CLICKING the link, please download this PDF first and then click on it.

CLICK HERE TO **DOWNLOAD** THE COMPLETE MANUAL

## 5) SWITCH PANEL

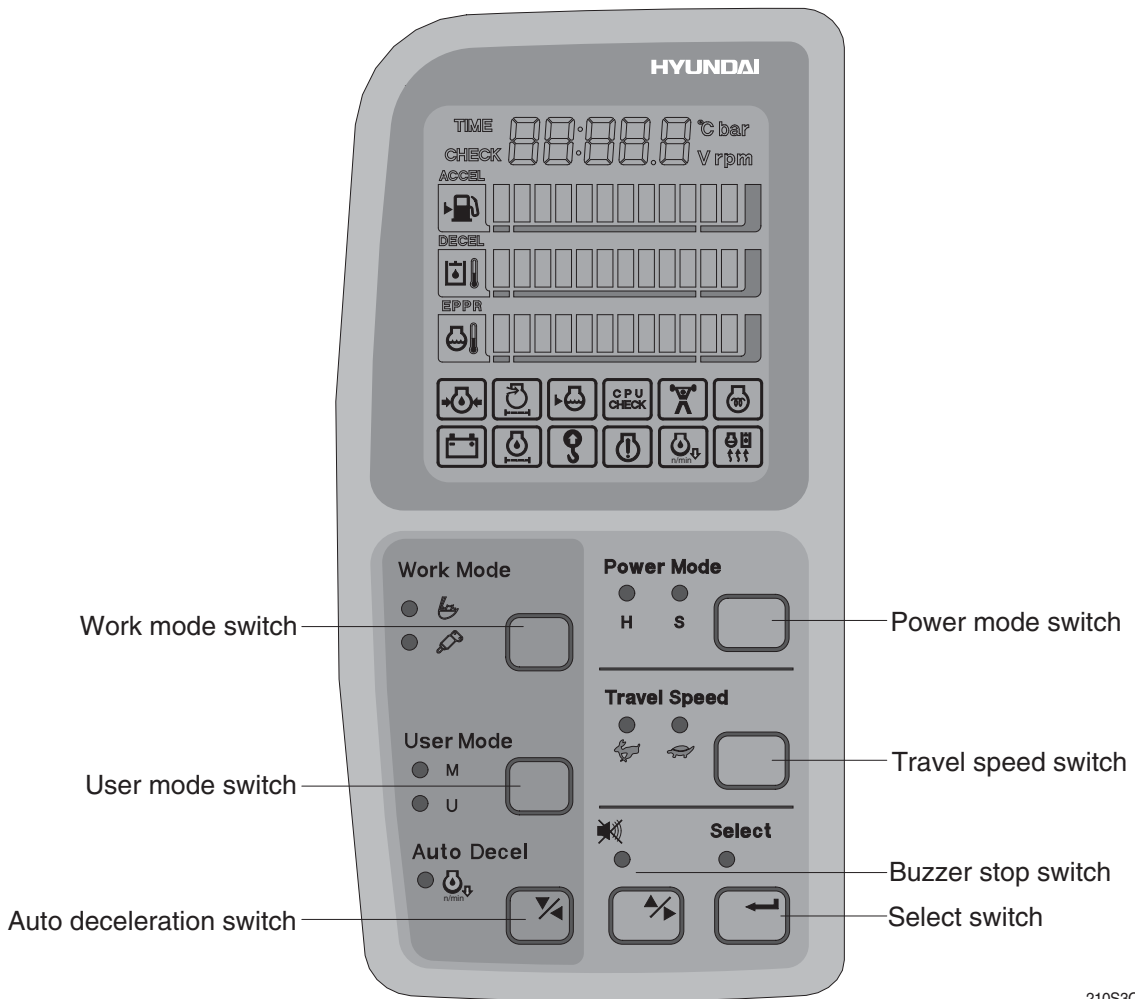

210S3CD19

### (1) Work mode switch

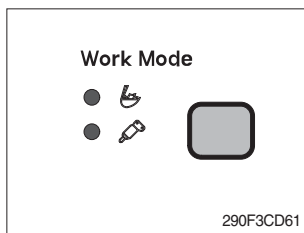

① This switch is to select the machine operation mode, which shifts from general operation mode to heavy operation mode and breaker mode in a row by pressing the switch.

- : Heavy duty work mode
- : Breaker operation mode

※ Refer to the operator's manual page 4-7 for details.

### (2) User mode switch

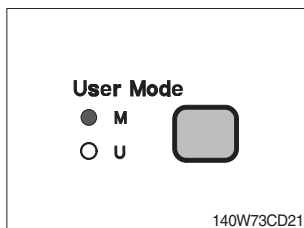

① This switch is to select the maximum power or user mode.

- M : Maximum power
- U : Memorizing operators preferable power setting

※ Refer to the operator's manual page 4-7 for details.

#### STEP 4. Inspect the trouble actually on the machine

In case that some trouble cannot be confirmed, obtain the details of the malfunction from the operator.

Also, check if there are any incomplete connections of the wire harnesses or not.

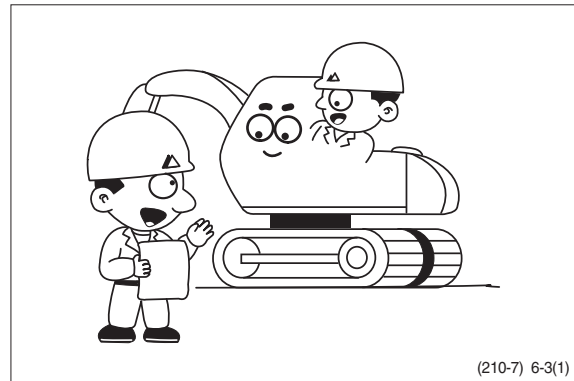

#### STEP 5. Perform troubleshooting

According to where the trouble parts are located, hydraulic & mechanical system part or electrical system part or mechatronics system part, perform troubleshooting the machine refer to the each system part's troubleshooting process diagram.

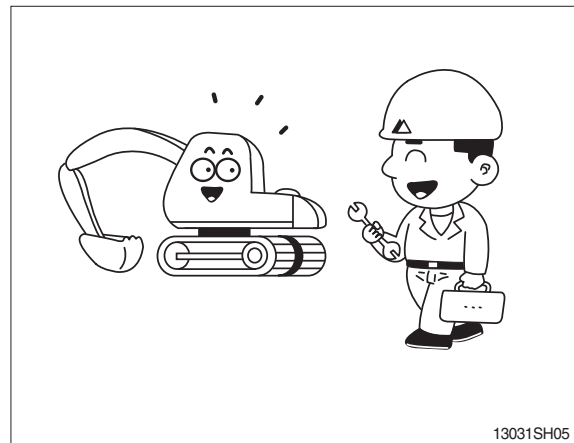

#### STEP 6. Trace a cause

Before reaching a conclusion, check the most susceptible causes again. Try to trace what the real cause of the trouble is.

Make a plan of the appropriate repairing procedure to avoid consequential malfunctions.

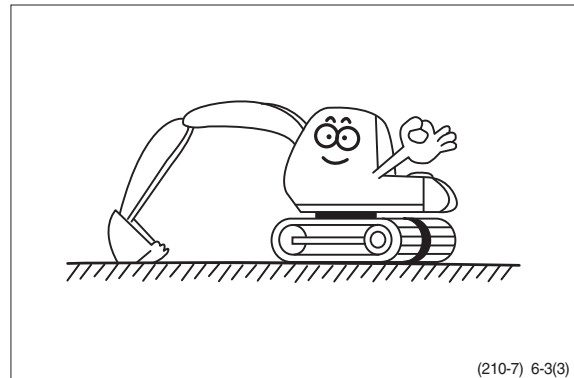



## ※ HOW TO CHECK INTERNAL BOOM CYLINDER LEAKAGE

1. Lower the bucket teeth to the ground with bucket cylinder fully retracted and arm cylinder rod retracted almost in full.

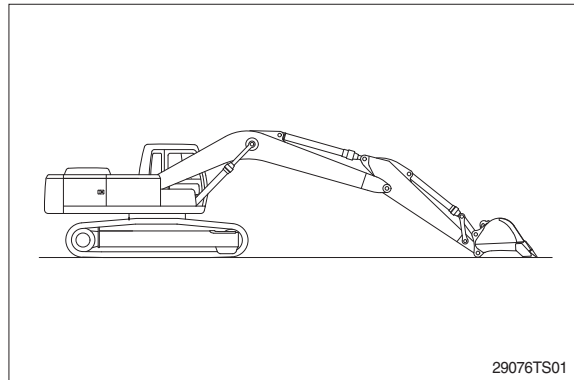

2. Disconnect hose(A) from rod side of boom cylinder and drain oil from cylinders and hose.(Put cups on piping and hose ends)

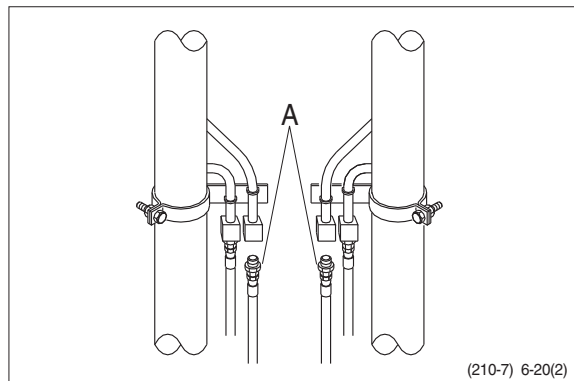

3. Raise bucket OFF the ground by retracting the arm cylinder rod.

If oil leaks from piping side and boom cylinder rod is retracted there is an internal leak in the cylinder.

If no oil leaks from piping side and boom cylinder rod is retracted, there is an internal leak in the control valve.

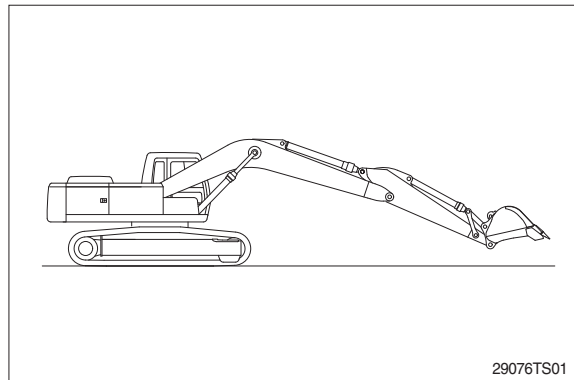

## 10. WHEN SAFETY SOLENOID DOES NOT OPERATE

- Before disconnecting the connector, always turn the starting switch OFF.
- Before carrying out below procedure, check all the related connectors are properly inserted and short of fuse No.26.
- After checking, insert the disconnected connectors again immediately unless otherwise specified.

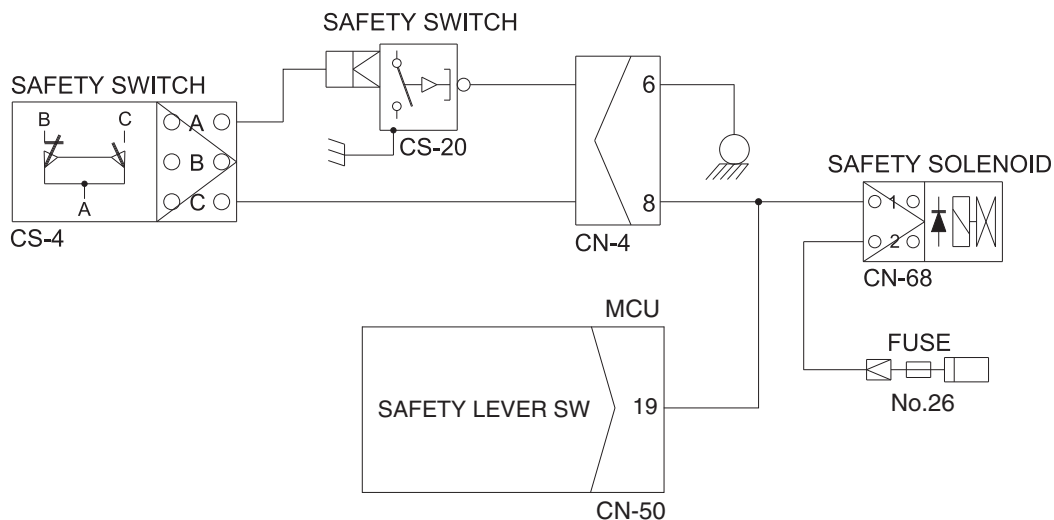
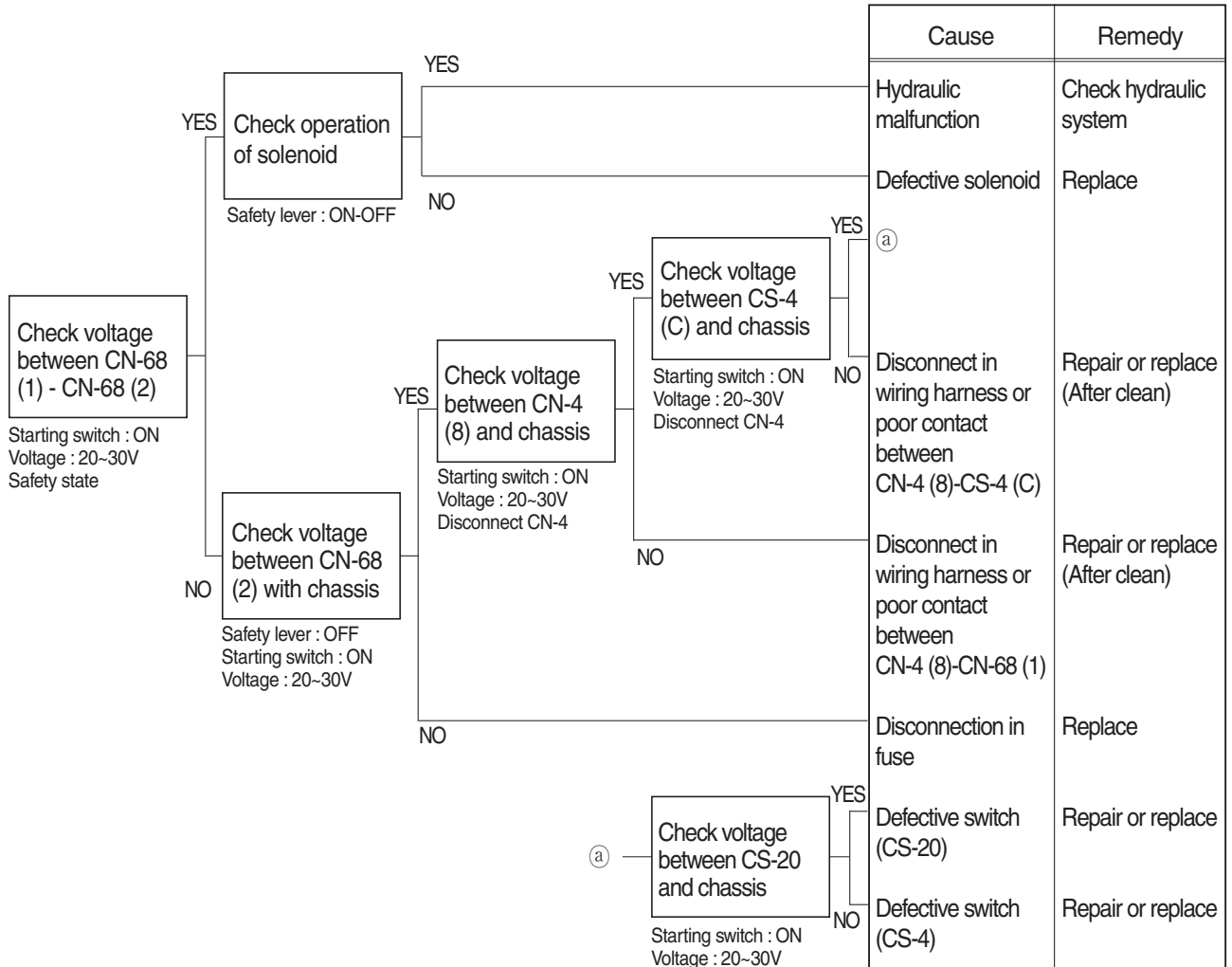

210S6ES59

## 2. ENGINE SPEED IS SLOW AT ALL MODE

※ Before carrying out below procedure, check all the related connectors are properly inserted.

### 1) INSPECTION PROCEDURE

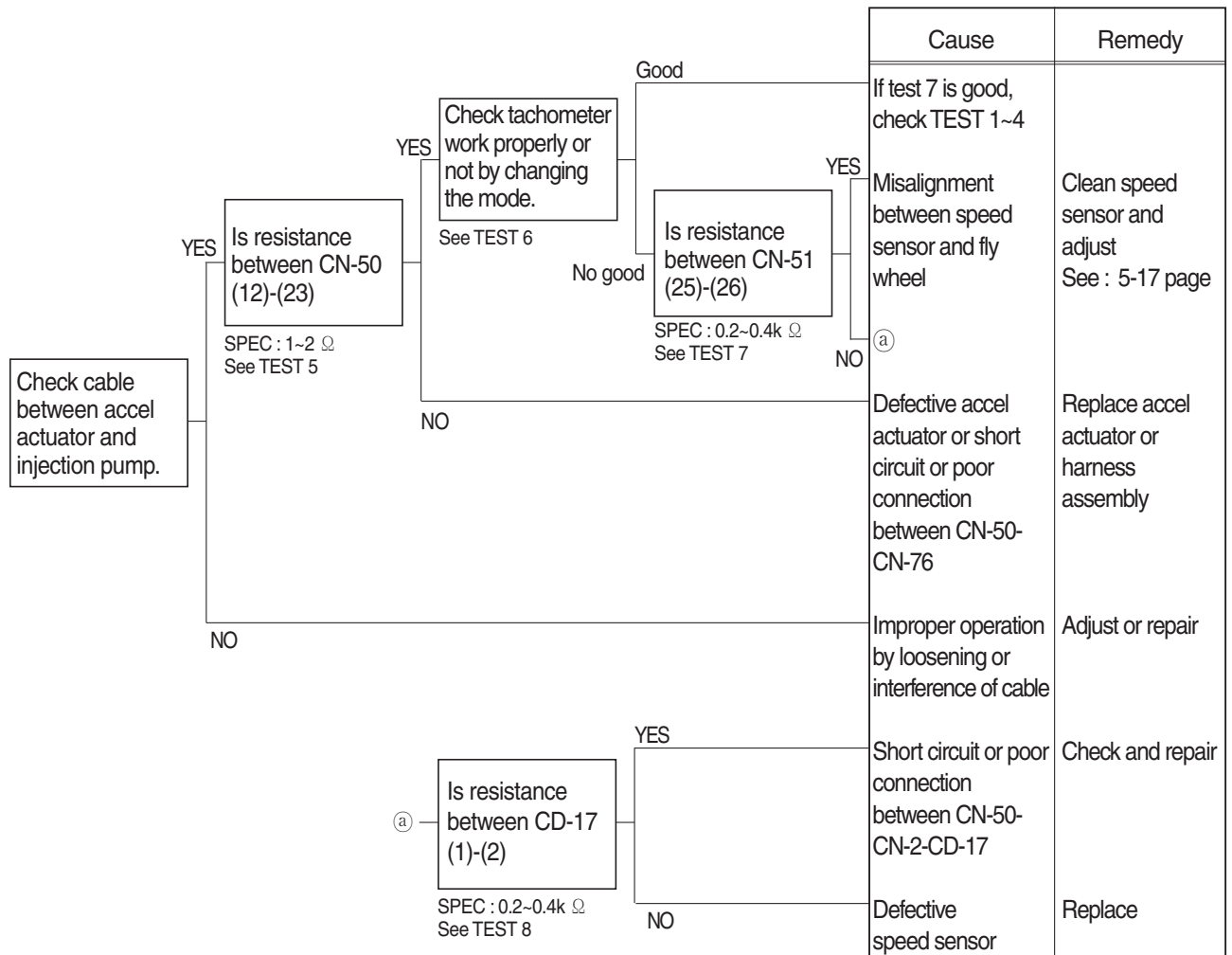

### Wiring diagram

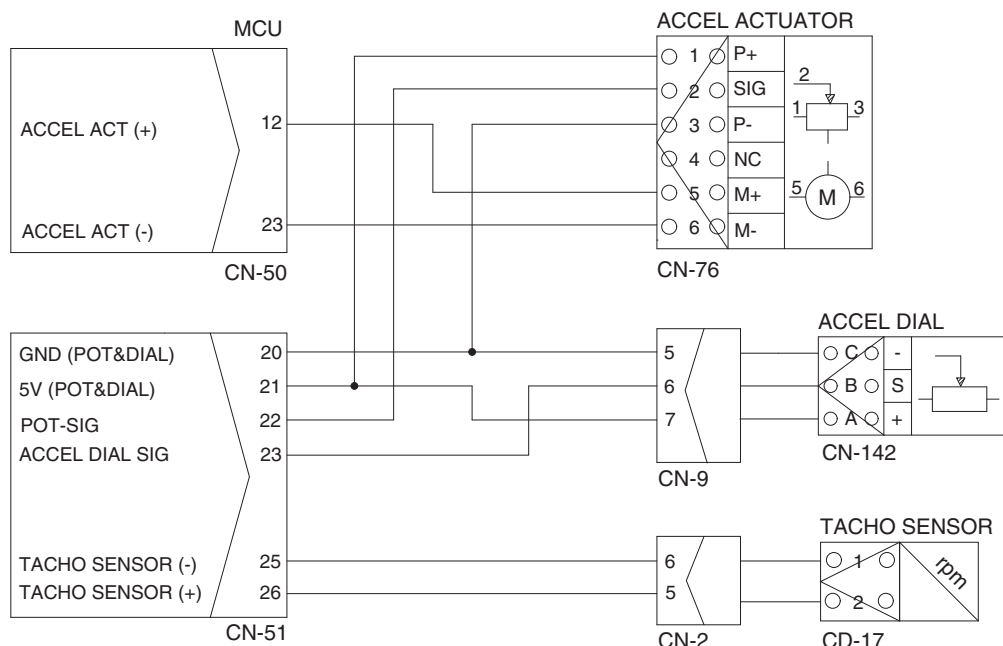

210S6MS03

## 2) TEST PROCEDURE

(1) **Test 13** : Check voltage at CN-51 (1) and ground.

- ① Prepare 1 piece of thin sharp pin, steel or copper.
- ② Starting switch ON.
- ③ Insert prepared pin to rear side of connectors : One pin to (1) of CN-51.
- ④ Check voltage as figure.

(2) **Test 14** : Check voltage at CN-51 (13) and ground.

- ① Prepare 1 piece of thin sharp pin, steel or copper
- ② Starting switch ON.
- ③ Insert prepared pin to rear side of connectors : One pin to (13) of CN-51.
- ④ Check voltage as figure.

SPEC : Actuator stop : 4~5 V  
Actuator operating : 0~1 V

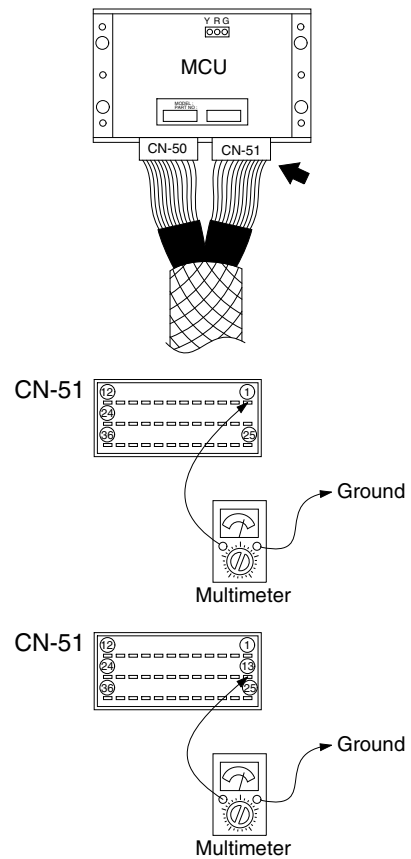

210S6MS11A

## 6) SWING SPEED

(1) Measure the time required to swing three complete turns.

### (2) Preparation

- ① Check the lubrication of the swing gear and swing bearing.
- ② Place the machine on flat, solid ground with ample space for swinging. Do not conduct this test on slopes.
- ③ With the arm rolled out and bucket rolled in, hold the bucket so that the height of the bucket pin is the same as the boom foot pin. The bucket must be empty.
- ④ Keep the hydraulic oil temperature at  $50 \pm 5^\circ\text{C}$ .

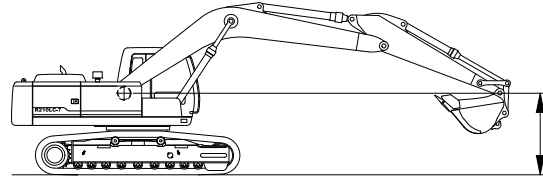

21077MS07

### (3) Measurement

- ① Select the following switch positions.
  - Power mode switch : M mode
- ② Operate swing control lever fully.
- ③ Swing 1 turn and measure time taken to swing next 3 revolutions.
- ④ Repeat steps ② and ③ three time and calculate the average values.

### (4) Evaluation

The time required for 3 swings should meet the following specifications.

Unit : Seconds / 3 revolutions

Model	Power mode switch	Standard	Maximum allowable
HX210S, HX220S	M mode	$14.7 \pm 1.5$	18.4

## 15) SWING PARKING BRAKE RELEASING PRESSURE

### (1) Preparation

- ① Stop the engine.
- ② Loosen the cap and relieve the pressure in the tank by pushing the top of the air breather.
- ③ The pressure release L wrench to bleed air.
- ④ Install a connector and pressure gauge assembly to swing motor SH port, as shown.
- ⑤ Start the engine and check for oil leakage from the adapter.
- ⑥ Keep the hydraulic oil temperature at  $50 \pm 5^{\circ}\text{C}$ .

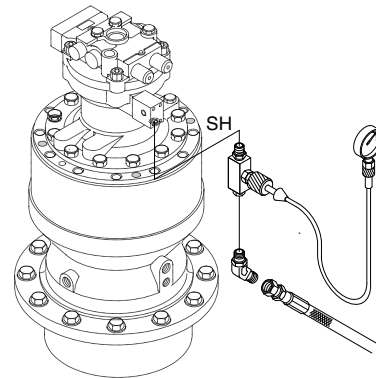

210S7MS15

### (2) Measurement

- ① Select the following switch positions.
  - Power mode switch : M mode
- ② Operate the swing function or arm roll in function and measure the swing brake control pressure with the brake disengaged. Release the control lever to return to neutral and measure the control pressure when the brake is applied. Repeat step ② three times and calculate the average values.

### (3) Evaluation

The average measured pressure should be within the following specifications.

Unit : kgf / cm<sup>2</sup>

Model	Description	Standard	Allowable limits	Remarks
HX210S	Brake disengaged	40	Over 9	
HX220S	Brake applied	0	-	

## 7. TURNING JOINT

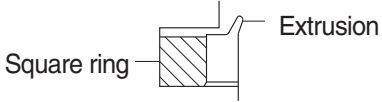
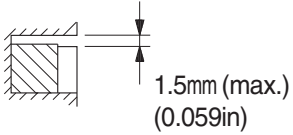
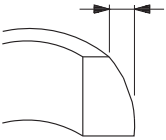
Part name		Maintenance standards	Remedy
Body, Stem	Sliding surface with sealing sections.	Plating worn or peeled due to seizure or contamination.	Replace
	Sliding surface between body and stem other than sealing section.	· Worn abnormality or damaged more than 0.1mm (0.0039in) in depth due to seizure contamination.	Replace
		· Damaged more than 0.1mm(0.0039in) in depth.	Smooth with oilstone.
	Sliding surface with thrust plate.	· Worn more than 0.5mm(0.02in) or abnormality.	Replace
· Worn less than 0.5mm(0.02in).		Smooth	
· Damage due to seizure or contamination remediable within wear limit (0.5mm)(0.02in).		Smooth	
Cover	Sliding surface with thrust plate.	· Worn more than 0.5mm(0.02in) or abnormality.	Replace
		· Worn less than 0.5mm(0.02in).	Smooth
		· Damage due to seizure or contamination remediable within wear limit (0.5mm)(0.02in).	Replace
Seal set	-	<ul style="list-style-type: none"> <li>· Extruded excessively from seal groove square ring.</li> </ul> 	Replace
	-	<ul style="list-style-type: none"> <li>· Slipper ring 1.5mm(0.059in) narrower than seal groove, or narrower than back ring.</li> </ul> 	Replace
	-	<ul style="list-style-type: none"> <li>· Worn more than 0.5mm(0.02in) ~ 1.5mm(MAX.) (0.059in)</li> </ul> 	Replace

# SECTION 8 DISASSEMBLY AND ASSEMBLY

## GROUP 1 PRECAUTIONS

### 1. REMOVAL WORK

- 1) Lower the work equipment completely to the ground.  
If the coolant contains antifreeze, dispose of it correctly.
- 2) After disconnecting hoses or tubes, cover them or fit blind plugs to prevent dirt or dust from entering.
- 3) When draining oil, prepare a container of adequate size to catch the oil.
- 4) Confirm the match marks showing the installation position, and make match marks in the necessary places before removal to prevent any mistake when assembling.
- 5) To prevent any excessive force from being applied to the wiring, always hold the connectors when disconnecting the connectors.
- 6) Fit wires and hoses with tags to show their installation position to prevent any mistake when installing.
- 7) Check the number and thickness of the shims, and keep in a safe place.
- 8) When raising components, be sure to use lifting equipment of ample strength.
- 9) When using forcing screws to remove any components, tighten the forcing screws alternately.
- 10) Before removing any unit, clean the surrounding area and fit a cover to prevent any dust or dirt from entering after removal.
- 11) When removing hydraulic equipment, first release the remaining pressure inside the hydraulic tank and the hydraulic piping.
- 12) If the part is not under hydraulic pressure, the following corks can be used.

Nominal number	Dimensions		
	D	d	L
06	6	5	8
08	8	6.5	11
10	10	8.5	12
12	12	10	15
14	14	11.5	18
16	16	13.5	20
18	18	15	22
20	20	17	25
22	22	18.5	28
24	24	20	30
27	27	22.5	34

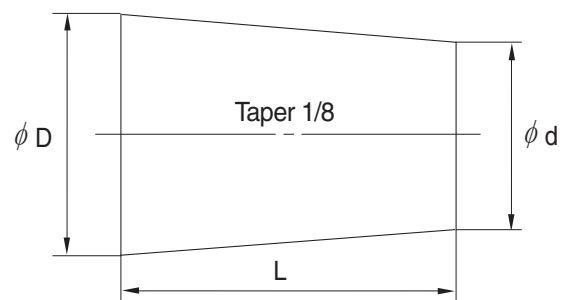

## 2) TOOLS AND TIGHTENING TORQUE

### (1) Tools

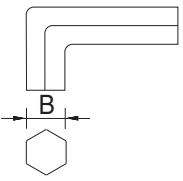
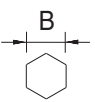

The tools necessary to disassemble/reassemble the pump are shown in the follow list.

Tool name & size		Part name			
Name	B	Hexagon socket head bolt	PT plug (PT thread)	PO plug (PF thread)	Hexagon socket head setscrew
Allen wrench 	4	M 5	BP-1/16	-	M 8
	5	M 6	BP-1/8	-	M10
	6	M 8	BP-1/4	PO-1/4	M12, M14
	8	M10	BP-3/8	PO-3/8	M16, M18
	17	M20, M22	BP-1	PO-1, 1 1/4, 1 1/2	-
Double ring spanner, socket wrench, double (single) open end spanner 	-	Hexagon socket head bolt	Hexagon nut	VP plug (PF thread)	
	19	M12	M12	VP-1/4	
	24	M16	M16	-	
	27	M18	M18	VP-1/2	
	30	M20	M20	-	
	36	-	-	VP-3/4	
Adjustable angle wrench		Medium size, 1 set			
Screw driver		Minus type screw driver, Medium size, 2 sets			
Hammer		Plastic hammer, 1 set			
Pliers		For snap ring, TSR-160			
Steel bar		Steel bar of key material approx. 10×8×200			
Torque wrench		Capable of tightening with the specified torques			

## 2) TOOLS AND TIGHTENING TORQUE

### (1) Tools

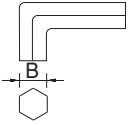
The tools necessary to disassemble/reassemble the pump are shown in the follow list.

Tool name & size		Part name			
Name	B	Hexagon socket head bolt	PT plug (PT thread)	PO plug (PF thread)	Hexagon socket head setscrew
Allen wrench 	4	M 5	BP-1/16	-	M 8
	5	M 6	BP-1/8	-	M10
	6	M 8	BP-1/4	PO-1/4	M12, M14
Double ring spanner, socket wrench, double (single) open end spanner 	-	Hexagon head bolt	Hexagon nut	VP plug (PF thread)	
	6	M 8	M 8	-	
Adjustable angle wrench		Small size, Max 36mm			
Screw driver		Minus type screw driver, Medium size, 2 sets			
Hammer		Plastic hammer, 1 set			
Pliers		For snap ring, TSR-160			
Steel bar		4 × 100 mm			
Torque wrench		Capable of tightening with the specified torques			
Pincers		-			
Bolt		M4, Length : 50 mm			

## 2. STRUCTURE (1/5)

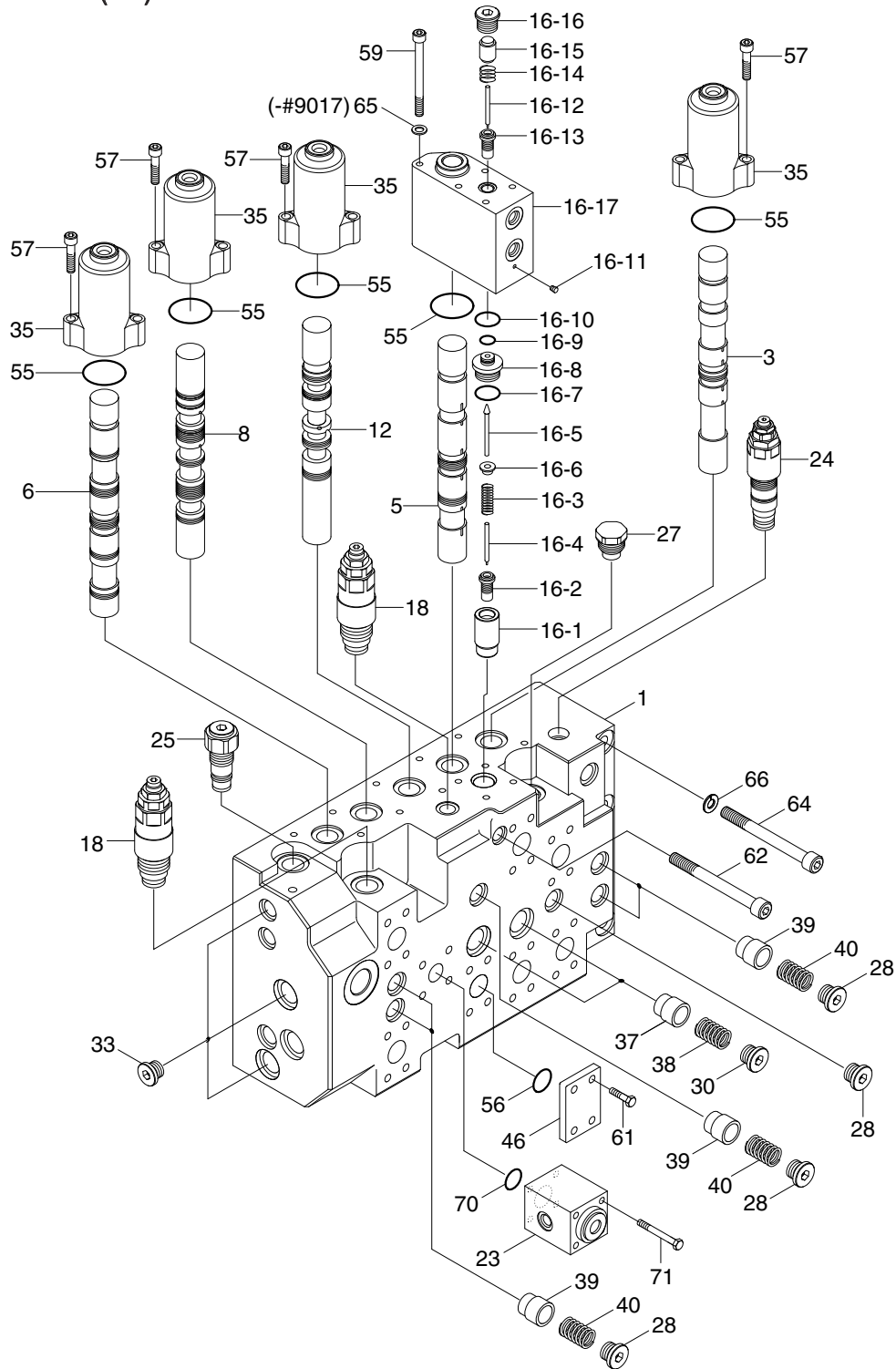

- |    |                        |    |                  |    |               |
|----|------------------------|----|------------------|----|---------------|
| 1  | P1 housing             | 27 | Overload plug    | 56 | O-ring        |
| 3  | Travel spool kit       | 28 | Plug             | 57 | Socket bolt   |
| 5  | Boom 1 spool kit       | 30 | Load check plug  | 59 | Socket bolt   |
| 6  | Bucket spool kit       | 33 | Plug             | 61 | Socket bolt   |
| 8  | Arm 2 spool kit        | 35 | Spool cap        | 62 | Socket bolt   |
| 12 | Arm regen spool kit    | 37 | L/C poppet 1     | 64 | Socket bolt   |
| 16 | Holding valve assy     | 38 | L/C spring 1     | 66 | Spring washer |
| 18 | Port relief valve assy | 39 | L/C poppet 2     | 70 | O-ring        |
| 23 | Arm 2 logic valve assy | 40 | L/C spring 2     | 71 | Socket bolt   |
| 24 | Main relief valve assy | 46 | Port plug flange |    |               |
| 25 | Negacon relief valve   | 55 | O-ring           |    |               |

220S8MC04

(12) Disassembling of logic valve  
(Arm logic valve (22), Swing logic valve  
(21) )

- ① Loosen the hexagon socket head bolts  
(56) 4EA and remove the logic valve.  
[ Hexagon key wrench 8 mm ]

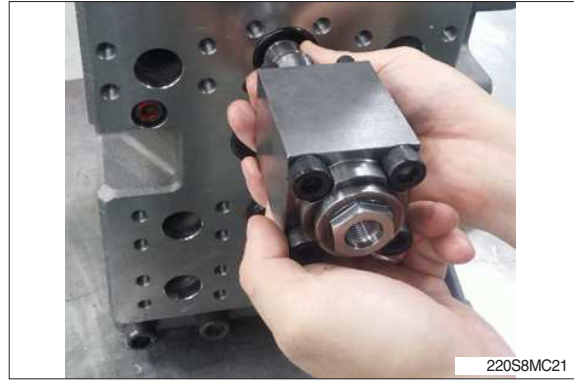

- ② Remove the swing logic poppet.



- ③ Remove the Arm logic poppet and spring  
by same method.

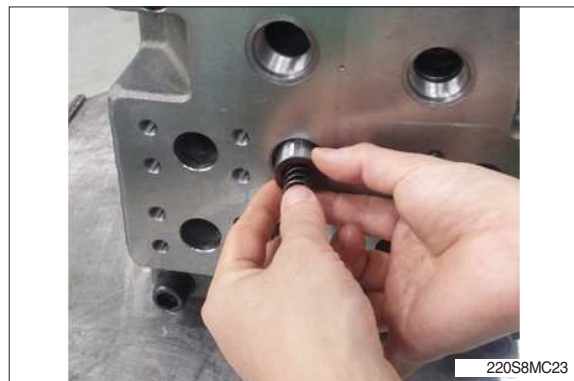

### 3) ASSEMBLING

#### (1) Assemble shaft sub

- ① Put roller bearing (3) on preheater and provide heat to inner race.  
(Temperature in conveyor : 120°C for 3~5 minutes)



2209A8SM66

- ② Using a robot machine, assemble and press preheated roller bearing (3) into shaft (5).



2209A8SM67

#### (2) Assemble cylinder block sub

- ① Assemble 9 springs (cylinder block, 9) into cylinder block (8).
  - Spring × 9EA



2209A8SM68

- ② Assemble ball guide (10) into cylinder block (8).
  - Ball guide × 1EA



2209A8SM69

④ Removing drive shaft sub assy

- a. Unscrew every hex head bolt (M12) to remove lock plate.

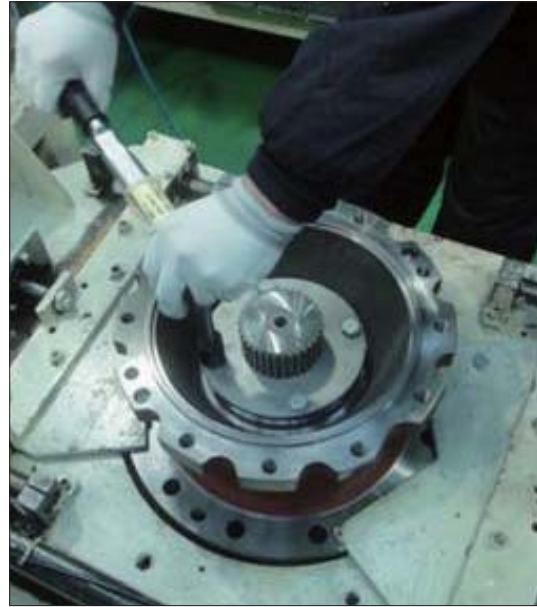

2209A8SM07

- b. Rolling ring nut for removing them from drive shaft sub assy.

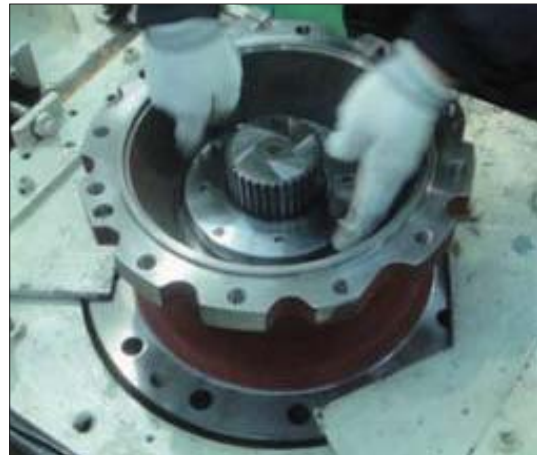

2209A8SM08

- ※ Use special tool to roll ring nut to counter clockwise.

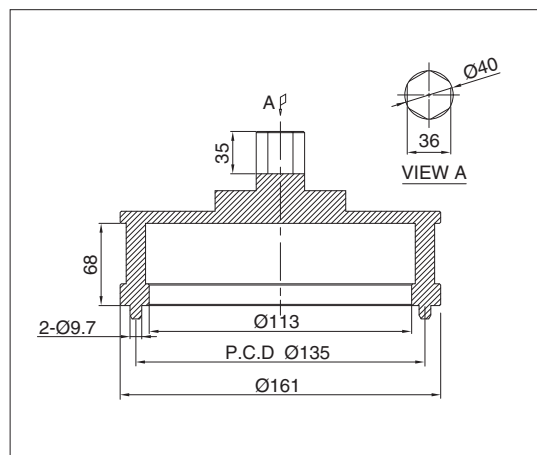

220L8SM01

## 6) ASSEMBLING RING GEAR

- (1) Apply loctite #515 bottom of casing sub assy contacting with ring gear without disconnection.



2209A8SM38

Refer to loctite detail.

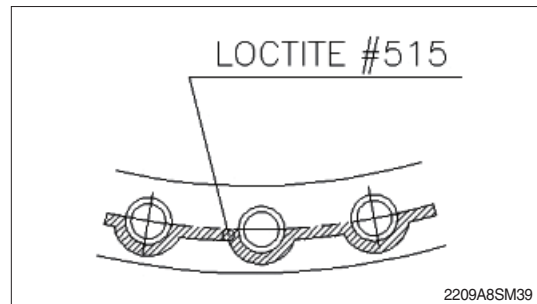

2209A8SM39

- (2) Put parallel pin into hole of casing sub assy.  
Mark parallel pin position using paint marker.

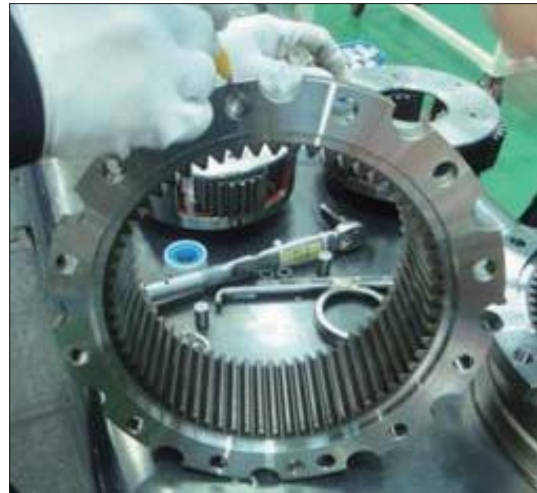

2209A8SM40

- (3) Align ring gear with parallel pin to put them into casing sub assy.  
※ Be sure to maintain them vertical with ground while using press.



2209A8SM41

- (5) Disassemble the parking piston (25) by using the jig for disassembling parking piston.

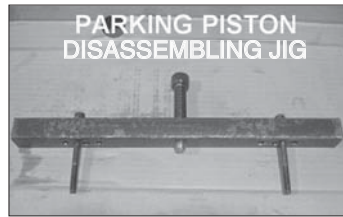

25098TM039

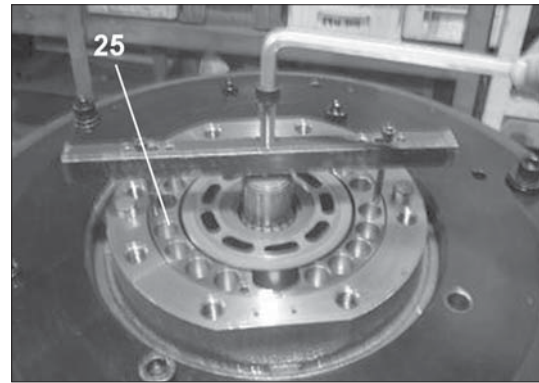

25098TM040

- (6) Disassemble the separated plate (24, 5EA) and friction plate (23, 4EA) from the casing.

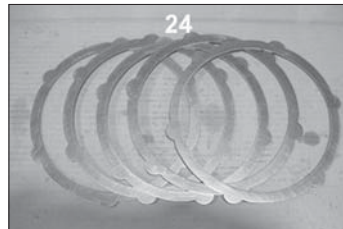

25098TM041

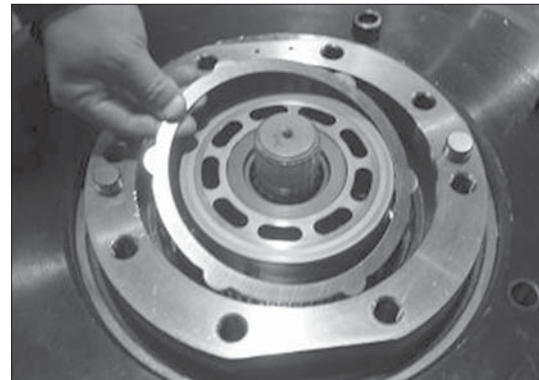

25098TM042

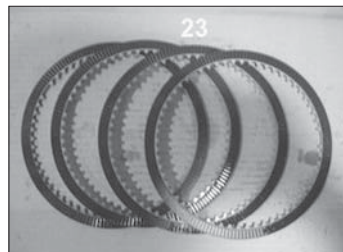

25098TM043

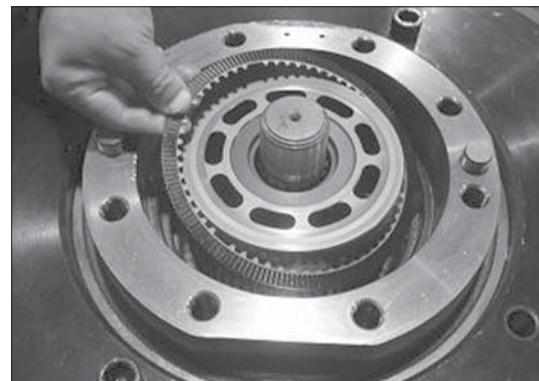

25098TM044

- (7) Turn the casing (1) horizontal by using the assemble truck and disassemble the cylinder block kit form the casing (1).

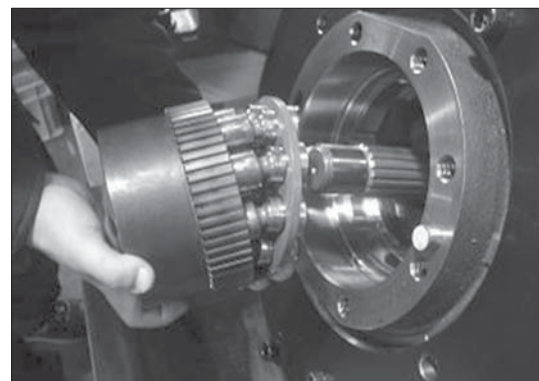

25098TM045

(20) Assemble the spring (19), ball guide (20), retainer plate (21) and piston assy (22) into cylinder block (18) in order.

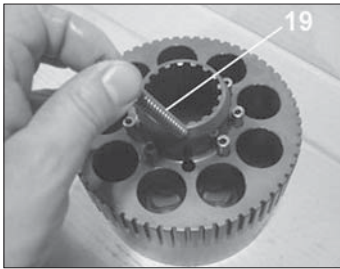

25098TM106

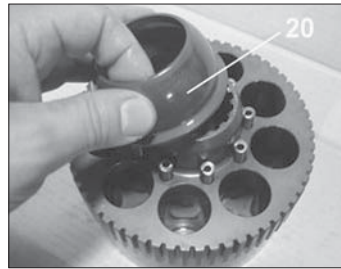

25098TM107

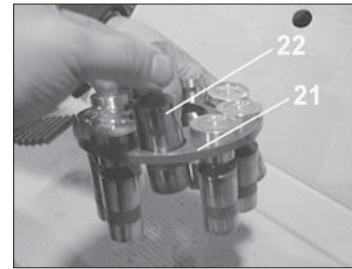

25098TM108

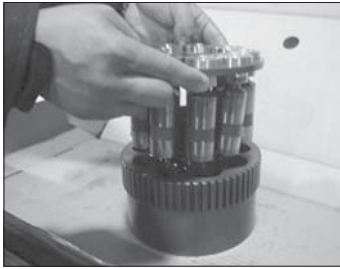

25098TM109



25098TM110

(21) Tilt the casing (1) sideways and assemble the cylinder block kit into the casing (1).

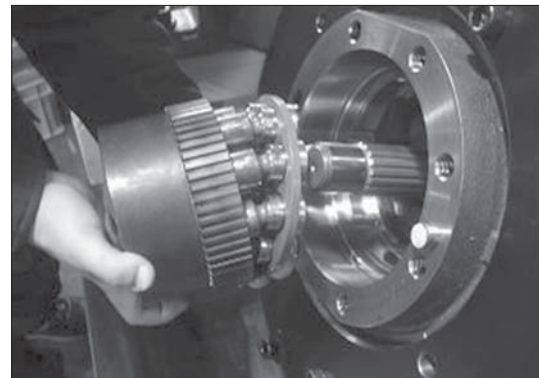

25098TM111

(22) Assemble the separated plate (24) and friction plate (23) into the cylinder block alternately.

Friction plate :

4EA

Separated plate :

5EA

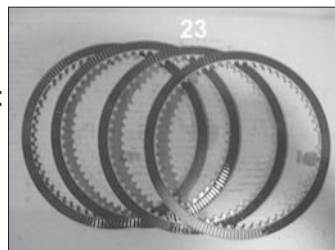

25098TM112

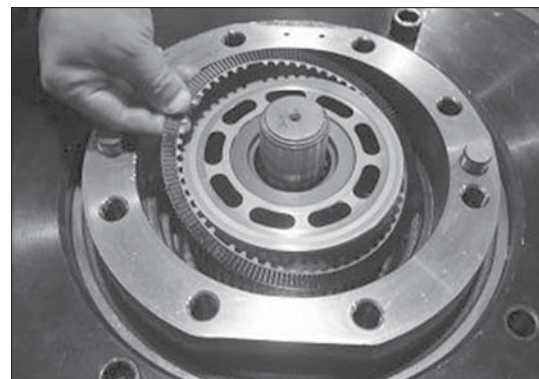

25098TM113

## 7. ASSEMBLY REDUCTION UNIT

### 1) GENERAL NOTES

- (1) Clean every part by kerosene and dry them by air blow.
  - (2) Surfaces to be applied by loctite must be decreased by solvent.
  - (3) Check every part for any abnormal.
  - (4) Each hexagon socket head bolt should be used with loctite No.242 applied on its threads.
  - (5) Apply gear oil slightly on each part before assembling.
- ▲ Take great care not to pinch your hand between parts or tools while assembling nor let fall parts on your foot while lifting them.  
Inspection before reassembling.

#### Thrust washer

- Check if there are seizure, abnormal wear or uneven wear.
- Check if wear is over the allowable limit.

#### Gear

- Check if there are pitting or seizure on the tooth surface.
- Check if there are cracks on the root of tooth by die check.

#### Bearing

- Rotate by hand to see if there are something unusual such as noise or uneven rotation.

#### Floating seal

- Check flaw or score on sliding surfaces or O-ring.

### 2) ASSEMBLING CARRIER 1 ASSY

- (1) Put No.1 carrier on a flat place.
- (2) Install No.1 needle bearing into No.1 planetary gear, put 2EA of No.1 thrust washer on both sides of planetary gear, and then, install it into carrier.

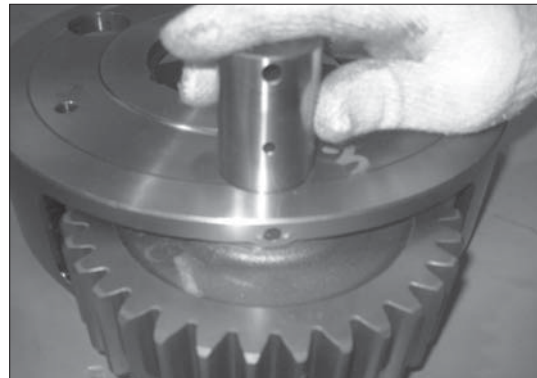

25098TM144

- (3) Install No.1 pin into No.1 carrier where the holes for No.1 pin are to be in line with those of No.1 carrier, and then, install spring pins into the holes.



25098TM145

- (6) Loosen adjusting nut (17) and swash plate (16) with spanners on them respectively, and remove them.

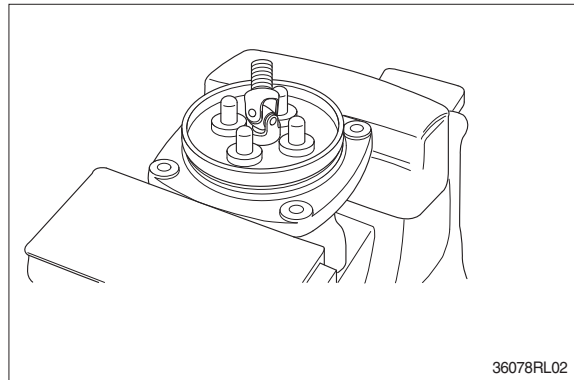
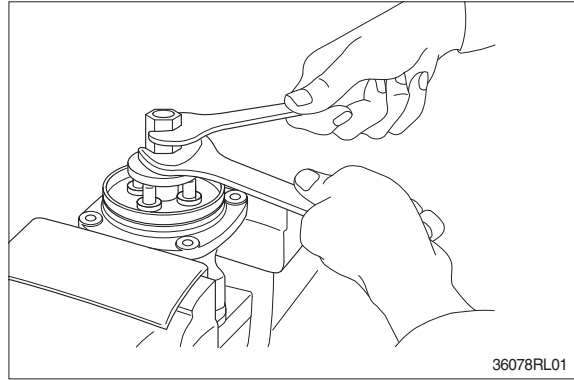

- (7) Turn joint anticlockwise to loosen it, utilizing jig (Special tool).

- ※ When return spring (7) is strong in force, plate (12), plug (8) and push rod (9) will come up on loosening joint. Pay attention to this.

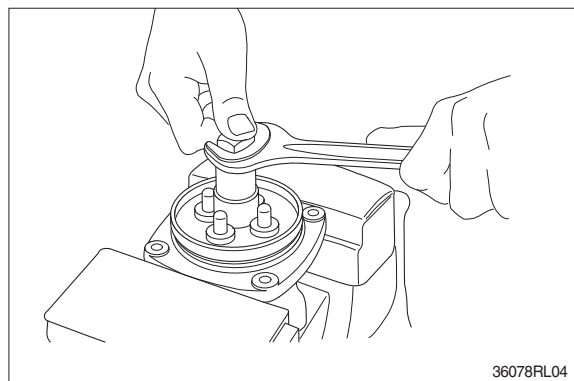
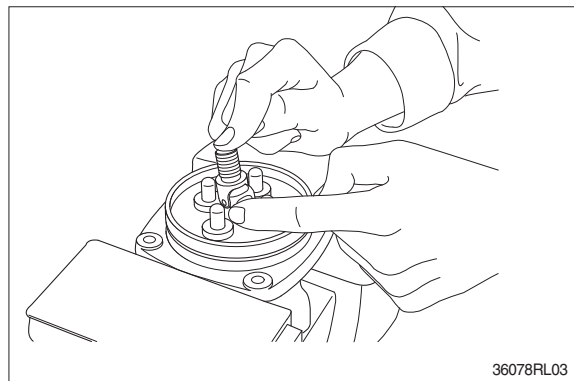

## GROUP 8 TURNING JOINT

### 1. REMOVAL AND INSTALL

#### 1) REMOVAL

- (1) Lower the work equipment to the ground and stop the engine.
- (2) Operate the control levers and pedals several times to release the remaining pressure in the hydraulic piping.
- (3) Loosen the breather slowly to release the pressure inside the hydraulic tank.
- ▲ **Escaping fluid under pressure can penetrate the skin causing serious injury.**
- ※ When pipes and hoses are disconnected, the oil inside the piping will flow out, so catch it in oil pan.
- (4) Disconnect all hoses.
- (5) Sling the turning joint assembly (1) and remove the mounting bolt (2).
  - Weight : 55 kg (120 lb)
  - Tightening torque :  $12.0 \pm 1.3 \text{ kgf} \cdot \text{m}$   
( $86.8 \pm 9.4 \text{ lbf} \cdot \text{ft}$ )
- (6) Remove the turning joint assembly.
- ※ When removing the turning joint, check that all the hoses have been disconnected.

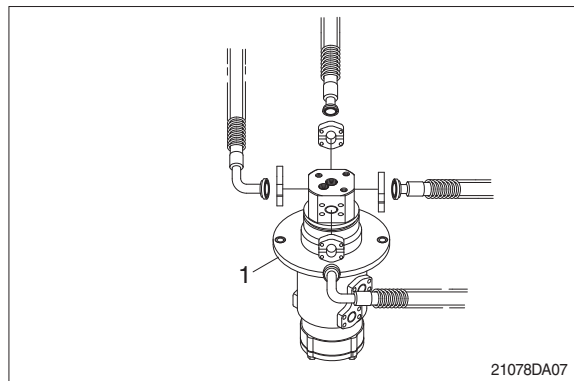

#### 2) INSTALL

- (1) Carry out installation in the reverse order to removal.
  - ※ Take care of turning joint direction.
  - ※ Assemble hoses to their original positions.
  - ※ Confirm the hydraulic oil level and check the hydraulic oil leak or not.

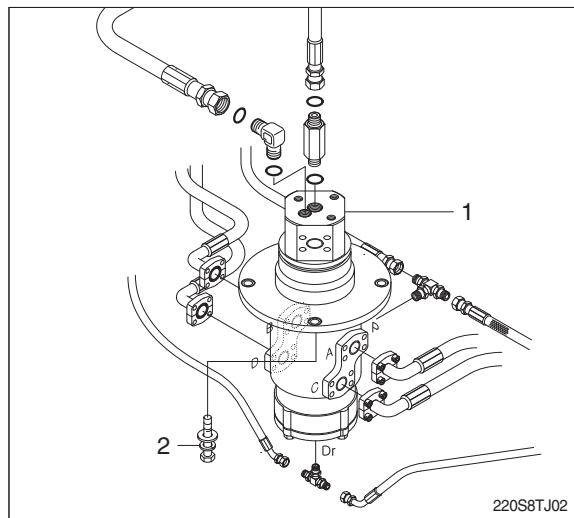

- ⑤ Disconnect boom cylinder hoses (7) and put plugs on cylinder pipe.

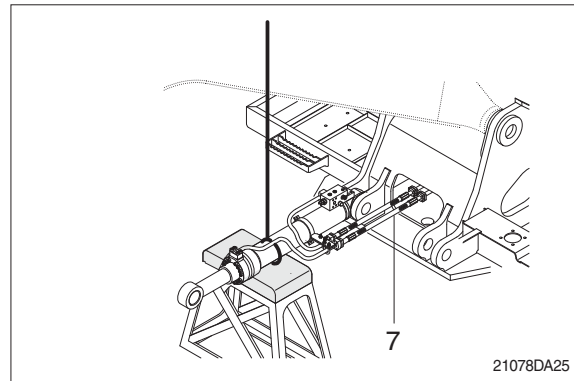

- ⑥ Remove bolt (9) and pull out pin (8).  
⑦ Remove boom cylinder assembly (6).  
· Weight : 180 kg (400 lb)

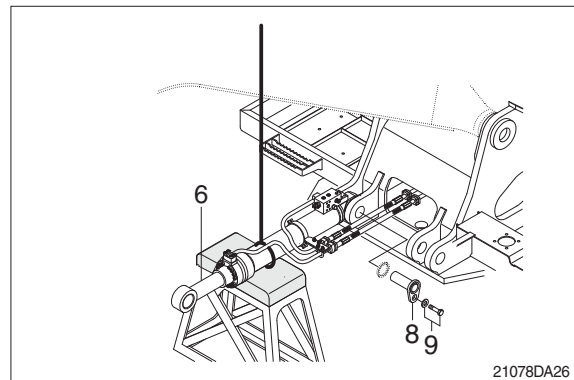

## (2) Install

- ① Carry out installation in the reverse order to removal.
- ▲ When aligning the mounting position of the pin, do not insert your fingers in the pin hole.**
- ※ Bleed the air from the boom cylinder.
  - ※ Confirmed the hydraulic oil level and check the hydraulic oil leak or not.

**(3) Install piston and cylinder head**

- ① Fix the rod assembly to the work bench.
- ② Apply hydraulic oil to the outer surface of rod assembly (2), the inner surface of piston and cylinder head.
- ③ Insert cylinder head assembly to rod assembly.

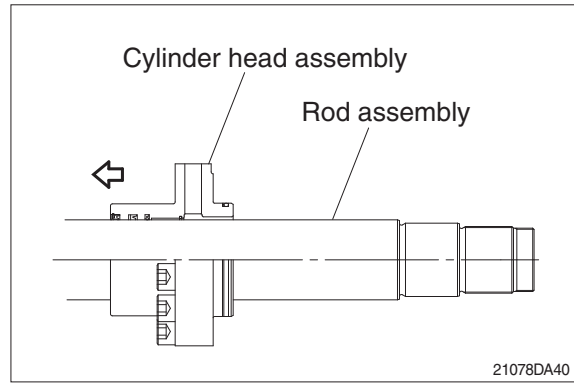

- ④ Insert cushion ring (13) to rod assembly.
- ※ Note that cushion ring (13) has a direction in which it should be fitted.

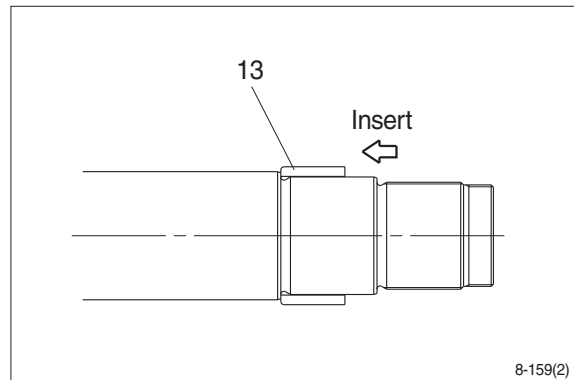

- ⑤ Fit piston assembly to rod assembly.
- Tightening torque :  $150 \pm 15 \text{ kgf} \cdot \text{m}$   
( $1085 \pm 108 \text{ lbf} \cdot \text{ft}$ )

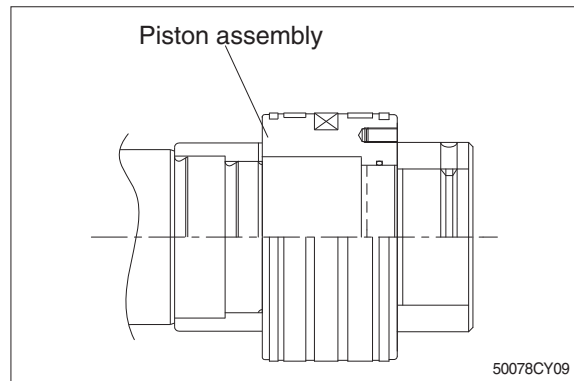

- ⑥ Fit lock nut (20) and tighten the screw (21).
- Tightening torque :

Item		kgf · m	lbf · ft
20	Bucket	$100 \pm 10$	$723 \pm 72.3$
	Boom	$100 \pm 10$	$723 \pm 72.3$
	Arm	$150 \pm 15$	$1085 \pm 108$
21	Bucket	$2.7 \pm 0.3$	$19.6 \pm 2.2$
	Boom	$2.7 \pm 0.3$	$19.5 \pm 2.2$
	Arm	$5.4 \pm 0.5$	$39.1 \pm 3.6$

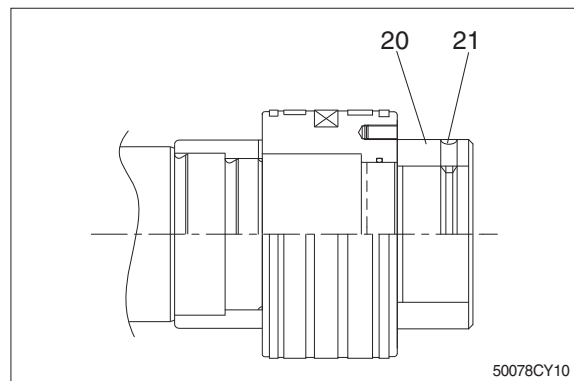

CLICK HERE TO **DOWNLOAD** THE COMPLETE MANUAL

- Thank you very much for reading the preview of the manual.
- You can download the complete manual from: [www.heydownloads.com](http://www.heydownloads.com) by clicking the link below



- Please note: If there is no response to CLICKING the link, please download this PDF first and then click on it.

CLICK HERE TO **DOWNLOAD** THE COMPLETE MANUAL