

SECTION 1 GENERAL

Group 1 Safety Hints	1-1
Group 2 Specifications (HW160)	1-9
Group 3 Specifications (HW180)	1-24

SECTION 2 STRUCTURE AND FUNCTION

Group 1 Pump Device	2-1
Group 2 Main Control Valve	2-20
Group 3 Swing Device (type 1)	2-47
Group 3 Swing Device (type 2)	2-58
Group 4 Travel Motor	2-69
Group 5 RCV Lever	2-75
Group 6 Accelerator Pedal	2-82
Group 7 Brake Pedal (Valve)	2-83
Group 8 Transmission	2-85
Group 9 Travel Control Valve	2-92
Group 10 Steering Valve	2-94
Group 11 Front Axle and Rear Axle	2-96

SECTION 3 HYDRAULIC SYSTEM

Group 1 Hydraulic Circuit	3-1
Group 2 Main Circuit	3-3
Group 3 Pilot Circuit	3-6
Group 4 Single Operation	3-17
Group 5 Combined Operation	3-32

SECTION 4 ELECTRICAL SYSTEM

Group 1 Component Location	4-1
Group 2 Electrical Circuit	4-3
Group 3 Electrical Component Specification	4-25
Group 4 Connectors	4-37

CLICK HERE TO **DOWNLOAD** THE COMPLETE MANUAL

- Thank you very much for reading the preview of the manual.
- You can download the complete manual from: www.heydownloads.com by clicking the link below



- Please note: If there is no response to CLICKING the link, please download this PDF first and then click on it.

CLICK HERE TO **DOWNLOAD** THE COMPLETE MANUAL

TEMPERATURE

Fahrenheit-Centigrade Conversion.

A simple way to convert a fahrenheit temperature reading into a centigrade temperature reading or vice verse is to enter the accompanying table in the center or boldface column of figures.

These figures refer to the temperature in either Fahrenheit or Centigrade degrees.

If it is desired to convert from Fahrenheit to Centigrade degrees, consider the center column as a table of Fahrenheit temperatures and read the corresponding Centigrade temperature in the column at the left.

If it is desired to convert from Centigrade to Fahrenheit degrees, consider the center column as a table of Centigrade values, and read the corresponding Fahrenheit temperature on the right.

°C	°F	°C	°F	°C	°F	°C	°F	°C	°F	°C	°F
-40.4	-40	-40.0	-11.7	11	51.8	7.8	46	114.8	27.2	81	117.8
-37.2	-35	-31.0	-11.1	12	53.6	8.3	47	116.6	27.8	82	179.6
-34.4	-30	-22.0	-10.6	13	55.4	8.9	48	118.4	28.3	83	181.4
-31.7	-25	-13.0	-10.0	14	57.2	9.4	49	120.2	28.9	84	183.2
-28.9	-20	-4.0	-9.4	15	59.0	10.0	50	122.0	29.4	85	185.0
-28.3	-19	-2.2	-8.9	16	60.8	10.6	51	123.8	30.0	86	186.8
-27.8	-18	-0.4	-8.3	17	62.6	11.1	52	125.6	30.6	87	188.6
-27.2	-17	1.4	-7.8	18	64.4	11.7	53	127.4	31.1	88	190.4
-26.7	-16	3.2	-6.7	20	68.0	12.8	55	131.0	32.2	90	194.0
-26.1	-15	5.0	-6.7	20	68.0	12.8	55	131.0	32.2	90	194.0
-25.6	-14	6.8	-6.1	21	69.8	13.3	56	132.8	32.8	91	195.8
-25.0	-13	8.6	-5.6	22	71.6	13.9	57	134.6	33.3	92	197.6
-24.4	-12	10.4	-5.0	23	73.4	14.4	58	136.4	33.9	93	199.4
-23.9	-11	12.2	-4.4	24	75.2	15.0	59	138.2	34.4	94	201.2
-23.3	-10	14.0	-3.9	25	77.0	15.6	60	140.0	35.0	95	203.0
-22.8	-9	15.8	-3.3	26	78.8	16.1	61	141.8	35.6	96	204.8
-22.2	-8	17.6	-2.8	27	80.6	16.7	62	143.6	36.1	97	206.6
-21.7	-7	19.4	-2.2	28	82.4	17.2	63	145.4	36.7	98	208.4
-21.1	-6	21.2	-1.7	29	84.2	17.8	64	147.2	37.2	99	210.2
-20.6	-5	23.0	-1.1	35	95.0	21.1	70	158.0	51.7	125	257.0
-20.0	-4	24.8	-0.6	31	87.8	18.9	66	150.8	40.6	105	221.0
-19.4	-3	26.6	0	32	89.6	19.4	67	152.6	43.3	110	230.0
-18.9	-2	28.4	0.6	33	91.4	20.0	68	154.4	46.1	115	239.0
-18.3	-1	30.2	1.1	34	93.2	20.6	69	156.2	48.9	120	248.0
-17.8	0	32.0	1.7	35	95.0	21.1	70	158.0	51.7	125	257.0
-17.2	1	33.8	2.2	36	96.8	21.7	71	159.8	54.4	130	266.0
-16.7	2	35.6	2.8	37	98.6	22.2	72	161.6	57.2	135	275.0
-16.1	3	37.4	3.3	38	100.4	22.8	73	163.4	60.0	140	284.0
-15.6	4	39.2	3.9	39	102.2	23.3	74	165.2	62.7	145	293.0
-15.0	5	41.0	4.4	40	104.0	23.9	75	167.0	65.6	150	302.0
-14.4	6	42.8	5.0	41	105.8	24.4	76	168.8	68.3	155	311.0
-13.9	7	44.6	5.6	42	107.6	25.0	77	170.6	71.1	160	320.0
-13.3	8	46.4	6.1	43	109.4	25.6	78	172.4	73.9	165	329.0
-12.8	9	48.2	6.7	44	111.2	26.1	79	174.2	76.7	170	338.0
-12.2	10	50.0	7.2	45	113.0	26.7	80	176.0	79.4	172	347.0

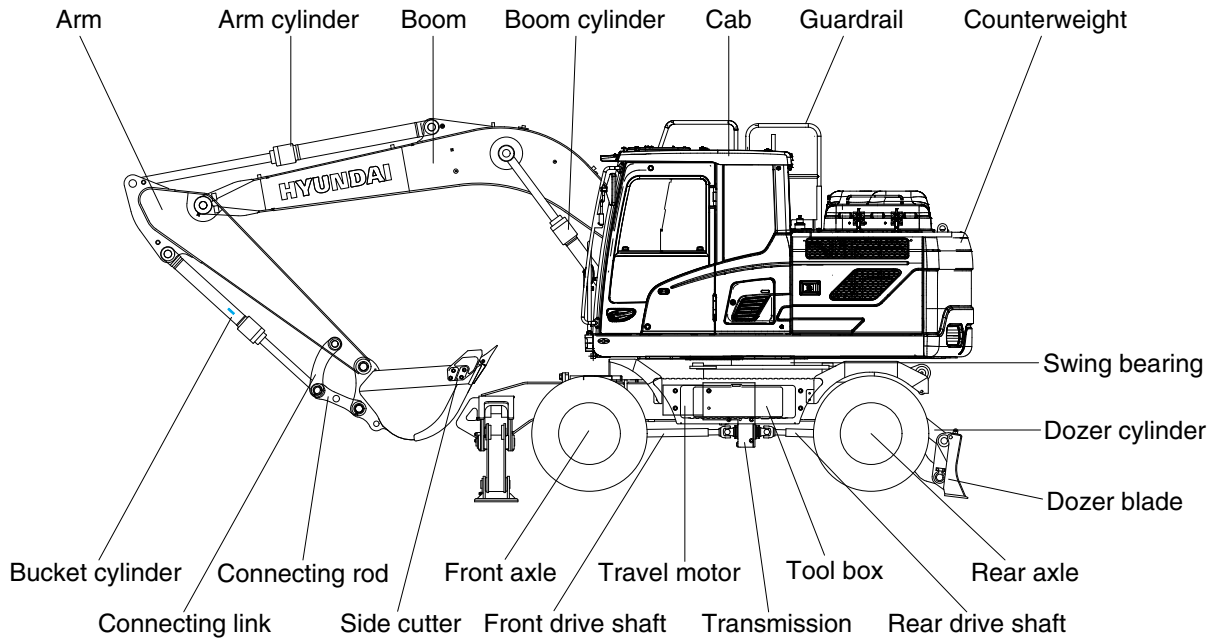
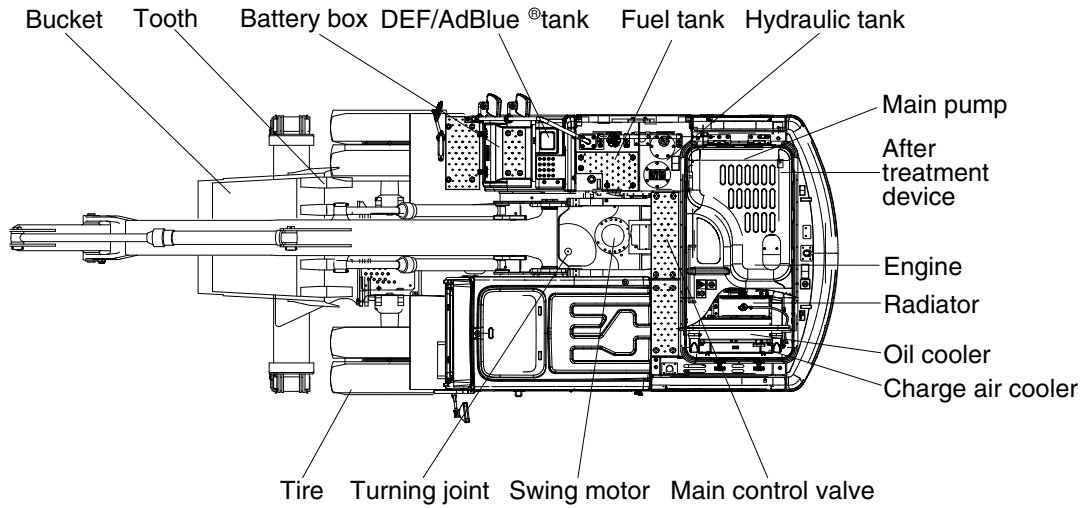

GROUP 2 SPECIFICATIONS (HW160)

1. MAJOR COMPONENT









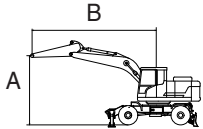
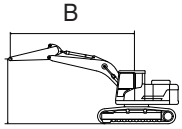





180WF2SP01



Model	Type	Boom	Arm	Counterweight	Shoe	Wheel	Dozer		Outrigger	
HW160	MONO BOOM	Length [mm]	Length [mm]	weight [kg]	width [mm]	width [mm]	Front	Rear	Front	Rear
		5000	2500	3150	-	500	-	Up	-	-

 : Rating over-front
  : Rating over-side or 360 degree









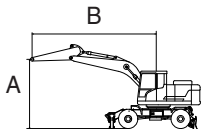
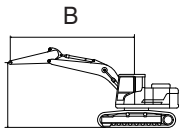



Lift-point height (A)		Lift-point radius (B)										At max. reach		
		1.5 m (4.9 ft)		3.0 m (9.8 ft)		4.5 m (14.8 ft)		6.0 m (19.7 ft)		7.5 m (24.6 ft)		Capacity		Reach m (ft)
														
6.0 m (19.7 ft)	kg							*3420	*3420			*2530	*2530	6.24 (20.5)
	lb							*7540	*7540			*5580	*5580	
4.5 m (14.8 ft)	kg					*4770	*4770	*4280	3730			*2430	*2430	7.02 (23.0)
	lb					*10520	*10520	*9440	8220			*5360	*5360	
3.0 m (9.8 ft)	kg					*5840	5400	*4710	3560			*2460	*2460	7.42 (24.3)
	lb					*12870	11900	*10380	7850			*5420	*5420	
1.5 m (4.9 ft)	kg					*6850	4990	4650	3380			*2600	2500	7.49 (24.6)
	lb					*15100	11000	10250	7450			*5730	5510	
Ground Line	kg			*5760	*5760	6870	4780	4520	3260			*2890	2570	7.25 (23.8)
	lb			*12700	*12700	15150	10540	9960	7190			*6370	5670	
-1.5 m (-4.9 ft)	kg	*5600	*5600	*9590	8920	6830	4740	4500	3250			*3480	2870	6.66 (21.9)
	lb	*12350	*12350	*21140	19670	15060	10450	9920	7170			*7670	6330	
-3.0 m (-9.8 ft)	kg	*9610	*9610	*8550	*8550	*6080	4870					*4510	3670	5.61 (18.4)
	lb	*21190	*21190	*18850	*18850	*13400	10740					*9940	8090	

Model	Type	Boom	Arm	Counterweight	Shoe	Wheel	Dozer		Outrigger	
HW160	2-PIECE BOOM	Length [mm]	Length [mm]	weight [kg]	width [mm]	width [mm]	Front	Rear	Front	Rear
		5100	2200	2650	-	500	-	Down	-	-

 : Rating over-front
  : Rating over-side or 360 degree

Lift-point height (A)		Lift-point radius (B)								At max. reach		
		3.0 m (9.8 ft)		4.5 m (14.8 ft)		6.0 m (19.7 ft)		7.5 m (24.6 ft)		Capacity		Reach m (ft)
												
7.5 m (24.6 ft)	kg			*5170	*5170					*4710	*4710	4.71 (15.4)
	lb			*11400	*11400					*10380	*10380	
6.0 m (19.7 ft)	kg			*4870	*4870	4590	3330			*3980	3210	6.11 (20.0)
	lb			*10740	*10740	10120	7340			*8770	7080	
4.5 m (14.8 ft)	kg			*5640	5220	4550	3290			3570	2580	6.90 (22.6)
	lb			*12430	11510	10030	7250			7870	5690	
3.0 m (9.8 ft)	kg			6950	4850	4390	3150			3210	2300	7.31 (24.0)
	lb			15320	10690	9680	6940			7080	5070	
1.5 m (4.9 ft)	kg			6580	4520	4240	3000			3110	2210	7.38 (24.2)
	lb			14510	9960	9350	6610			6860	4870	
Ground Line	kg			6410	4370	4140	2910			3240	2300	7.14 (23.4)
	lb			14130	9630	9130	6420			7140	5070	
-1.5 m (-4.9 ft)	kg	*9770	8460	6400	4360	4140	2910			3690	2620	6.54 (21.4)
	lb	*21540	18650	14110	9610	9130	6420			8140	5780	

9) CYLINDER

Item		Specification
Boom cylinder	Bore dia × Rod dia × Stroke	Ø 110 × Ø 75 × 1090mm
	Cushion	Extend only
Arm cylinder	Bore dia × Rod dia × Stroke	Ø 115 × Ø 80 × 1235mm
	Cushion	Extend and retract
Bucket cylinder	Bore dia × Rod dia × Stroke	Ø 105 × Ø 75 × 995mm
	Cushion	Extend only
Dozer cylinder	Bore dia × Rod dia × Stroke	Ø 110 × Ø 65 × 235mm
	Cushion	-
Outrigger cylinder	Bore dia × Rod dia × Stroke	Ø 125 × Ø 75 × 463mm
	Cushion	-
Adjust cylinder	Bore dia × Rod dia × Stroke	Ø 160 × Ø 95 × 650mm
	Cushion	-
2-piece boom cylinder	Bore dia × Rod dia × Stroke	Ø 110 × Ø 75 × 960mm
	Cushion	Extend only

※ Discoloration of cylinder rod can occur when the friction reduction additive of lubrication oil spreads on the rod surface.

※ Discoloration does not cause any harmful effect on the cylinder performance.

10) BUCKET

Item	Capacity		Tooth quantity	Width	
	SAE heaped	CECE heaped		Without side cutter	With side cutter
HW160	0.70 m ³ (0.92 yd ³)	0.60 m ³ (0.78 yd ³)	5	1020 mm (40.2")	1110 mm (43.7")
	0.39 m ³ (0.51 yd ³)	0.34 m ³ (0.44 yd ³)	3	650 mm (25.6")	740 mm (29.1")
	0.50 m ³ (0.65 yd ³)	0.44 m ³ (0.58 yd ³)	4	790 mm (31.1")	880 mm (34.6")
	0.64 m ³ (0.84 yd ³)	0.55 m ³ (0.72 yd ³)	5	950 mm (37.4")	1040 mm (40.9")
	0.76 m ³ (0.99 yd ³)	0.65 m ³ (0.85 yd ³)	5	1090 mm (42.9")	1180 mm (46.5")
	0.89 m ³ (1.16 yd ³)	0.77 m ³ (1.01 yd ³)	6	1250 mm (49.2")	1340 mm (52.8")
	1.05 m ³ (1.37 yd ³)	0.90 m ³ (1.18 yd ³)	6	1430 mm (56.3")	1520 mm (59.8")
	◎ 0.69 m ³ (0.90 yd ³)	0.62 m ³ (0.81 yd ³)	5	1050 mm (41.3")	-
	◎ 0.72 m ³ (0.94 yd ³)	0.65 m ³ (0.85 yd ³)	5	940 mm (37.0")	985 mm (38.8")
	◎ 0.87 m ³ (1.18 yd ³)	0.78 m ³ (1.02 yd ³)	5	1090 mm (42.9")	1140 mm (44.9")
	★ 0.75 m ³ (0.98 yd ³)	0.65 m ³ (0.85 yd ³)	-	1820 mm (71.7")	-

◎ : Heavy duty bucket

★ : Ditch cleaning bucket

Model	Type	Boom	Arm	Counterweight	Shoe	Wheel	Dozer		Outrigger	
HW180	MONO BOOM	Length [mm]	Length [mm]	weight [kg]	width [mm]	width [mm]	Front	Rear	Front	Rear
		5200	2600	3150	500	-	-	Up	-	-



: Rating over-front



: Rating over-side or 360 degree

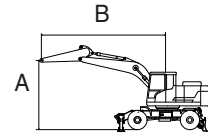

Lift-point height (A)	Lift-point radius (B)										At max. reach				
	1.5 m (4.9 ft)		3.0 m (9.8 ft)		4.5 m (14.8 ft)		6.0 m (19.7 ft)		7.5 m (24.6 ft)		Capacity		Reach		
													m (ft)		
7.5 m (24.6 ft)	kg											*2990	*2990	5.32	
	lb											*6590	*6590	(17.4)	
6.0 m (19.7 ft)	kg						*4230	3530				*2640	*2640	6.59	
	lb						*9330	7780				*5820	*5820	(21.6)	
4.5 m (14.8 ft)	kg				*5050	*5050	*4470	3460				*2540	2480	7.34	
	lb				*11130	*11130	*9850	7630				*5600	5470	(24.1)	
3.0 m (9.8 ft)	kg				*6360	5040	5010	3310	3540	2350		*2570	2240	7.72	
	lb				*14020	11110	11050	7300	7800	5180		*5670	4940	(25.3)	
1.5 m (4.9 ft)	kg				7520	4710	4840	3160	3470	2290		*2730	2160	7.79	
	lb				16580	10380	10670	6970	7650	5050		*6020	4760	(25.6)	
0.0 m (0.0 ft)	kg				*5200	*5200	7310	4530	4720	3050	3430	2250	*3040	2220	7.57
	lb				*11460	*11460	16120	9990	10410	6720	7560	4960	*6700	4890	(24.8)
-1.5 m (-4.9 ft)	kg	*5380	*5380	*9280	8380	7260	4490	4680	3020				*3660	2460	7.01
	lb	*11860	*11860	*20460	18470	16010	9900	10320	6660				*8070	5420	(23.0)
-3.0 m (-9.8 ft)	kg	*9680	*9680	*9840	8530	*6950	4550	*4760	3090				*4700	3070	6.03
	lb	*21340	*21340	*21690	18810	*15320	10030	*10490	6810				*10360	6770	(19.8)

Model	Type	Boom	Arm	Counterweight	Shoe	Wheel	Dozer		Outrigger	
HW180	MONO BOOM	Length [mm]	Length [mm]	weight [kg]	width [mm]	width [mm]	Front	Rear	Front	Rear
		5200	3100	3150	500	-	-	Up	-	-



: Rating over-front



: Rating over-side or 360 degree

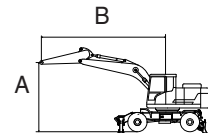

Lift-point height (A)	Lift-point radius (B)										At max. reach				
	1.5 m (4.9 ft)		3.0 m (9.8 ft)		4.5 m (14.8 ft)		6.0 m (19.7 ft)		7.5 m (24.6 ft)		Capacity		Reach		
													m (ft)		
7.5 m (24.6 ft)	kg											*2380	*2380	5.95	
	lb											*5250	*5250	(19.5)	
6.0 m (19.7 ft)	kg							*3760	3580				*2150	*2150	7.10
	lb							*8290	7890				*4740	*4740	(23.3)
4.5 m (14.8 ft)	kg							*4080	3490	*3060	2410		*2090	*2090	7.80
	lb							*8990	7690	*6750	5310		*4610	*4610	(25.6)
3.0 m (9.8 ft)	kg				*8740	*8740	*5800	5120	*4680	3330	3540	2350	*2120	2040	8.16
	lb				*19270	*19270	*12790	11290	*10320	7340	7800	5180	*4670	4500	(26.8)
1.5 m (4.9 ft)	kg						*7150	4750	4840	3160	3460	2270	*2250	1970	8.23
	lb						*15760	10470	10670	6970	7630	5000	*4960	4340	(27.0)
0.0 m (0.0 ft)	kg				*5890	*5890	7300	4520	4700	3020	3390	2210	*2510	2010	8.02
	lb				*12990	*12990	16090	9960	10360	6660	7470	4870	*5530	4430	(26.3)
-1.5 m (-4.9 ft)	kg	*5000	*5000	*8730	8250	7200	4430	4630	2960				*2990	2200	7.49
	lb	*11020	*11020	*19250	18190	15870	9770	10210	6530				*6590	4850	(24.6)
-3.0 m (-9.8 ft)	kg	*8300	*8300	*10660	8370	7230	4460	4660	2990				*3990	2650	6.59
	lb	*18300	*18300	*23500	18450	15940	9830	10270	6590				*8800	5840	(21.6)
-4.5 m (-14.8 ft)	kg				*7860	*7860	*5360	4630					*4390	3910	5.09
	lb				*17330	*17330	*11820	10210					*9680	8620	(16.7)

8. RECOMMENDED OILS

HD Hyundai Construction Equipment genuine lubricating oils have been developed to offer the best performance and service life for your equipment. These oils have been tested according to the specifications of HD Hyundai Construction Equipment and, therefore, will meet the highest safety and quality requirements. We recommend that you use only HD Hyundai Construction Equipment genuine lubricating oils and grease officially approved by HD Hyundai Construction Equipment.

Service point	Kind of fluid	Capacity ℓ (U.S. gal)	Ambient temperature °C (°F)								
			-50 (-58)	-30 (-22)	-20 (-4)	-10 (14)	0 (32)	10 (50)	20 (68)	30 (86)	40 (104)
Engine oil pan	Engine oil	23.7 (6.3)	★SAE 5W-40			SAE 30					
Transmission case			2.5 (0.7)	SAE 10W			SAE 10W-30				
				SAE 15W-40							
DEF/ AdBlue® tank	Mixture of urea and deionized water	27.0 (7.1)	ISO 22241, High-purity urea + deionized water (32.5:67.5)								
Swing drive	Gear oil	See page 6-37	★SAE 75W-90			SAE 80W-90					
Front axle			Gear oil	Center : 10.5 (2.8) Hub : 2.5×2 (0.7×2)	SAE 85W-90 LSD or UTTO						
Rear axle		Center : 12.5 (3.3) Hub : 2.5×2 (0.7×2)									
Front wide axle	Gear oil	Center : 11.6 (3.06) Hub : 2.5×2 (0.7×2)	SAE 85W-90 LSD or UTTO								
Rear wide axle			Center : 14.0 (3.70) Hub : 2.5×2 (0.7×2)								
Hydraulic tank	Hydraulic oil	Tank: 125 (33.0)	★ISO VG 15			ISO VG 32					
		System: 270 (71.3)	ISO VG 46, HBHO VG 46★ ³			ISO VG 68					
Fuel tank	Diesel fuel★ ¹	290 (76.6)	★ASTM D975 NO.1			ASTM D975 NO.2					
Fitting (Grease nipple)	Grease	As required	★NLGI NO.1			NLGI NO.2					
Radiator (Reservoir tank)			Mixture of antifreeze and soft water★ ²	19.5 (5.2)	Ethylene glycol base permanent type (50 : 50)						
					★Ethylene glycol base permanent type (60 : 40)						

SAE : Society of Automotive Engineers

API : American Petroleum Institute

ISO : International Organization for Standardization

NLGI : National Lubricating Grease Institute

ASTM : American Society of Testing and Material

UTTO : Universal Tractor Transmission Oil

DEF : Diesel Exhaust Fluid, DEF compatible with AdBlue®

★ : Cold region

Russia, CIS, Mongolia

★¹ : Ultra low sulfur diesel

- sulfur content ≤ 15 ppm

★² : Soft water

City water or distilled water

★³ : HD Hyundai Construction Equipment Bio Hydraulic Oil

※ Using any lubricating oils other than HD Hyundai Construction Equipment genuine products may lead to a deterioration of performance and cause damage to major components.

※ Do not mix HD Hyundai Construction Equipment genuine oil with any other lubricating oil as it may result in damage to the systems of major components.

※ Do not use any engine oil other than that specified above, as it may clog the diesel particulate filter(DPF).

※ For HD Hyundai Construction Equipment genuine lubricating oils and grease for use in regions with extremely low temperatures, please contact HD Hyundai Construction Equipment dealers.

2) REGULATOR

Regulator consists of the negative flow control, total horse power control and power shift control function.

(1) Negative flow control

By changing the pilot pressure P_i , the pump tilting angle (delivery flow) is regulated arbitrarily, as shown in the figure.

This regulator is of the negative flow control in which the delivery flow Q decreases as the pilot pressure P_i rises.

With this mechanism, when the pilot pressure corresponding to the flow required for the work is commanded, the pump discharges the required flow only, and so it does not consume the power uselessly.

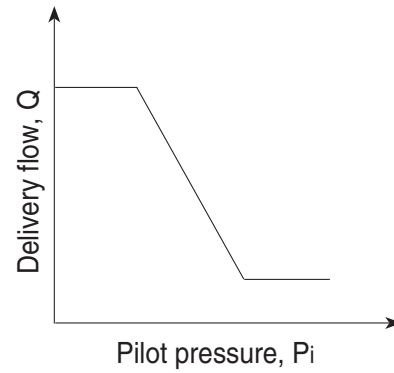

(4) Adjustment of maximum and minimum flows

① Adjustment of maximum flow

Adjust it by loosening the hexagon nut (808) and by tightening (or loosening) the set screw (954).

The maximum flow only is adjusted without changing other control characteristics.

Speed	Adjustment of max flow	
	Tightening amount of adjusting screw (954)	Flow change amount
(min ⁻¹)	(Turn)	(l/min)
2100	+1/4	-3.4

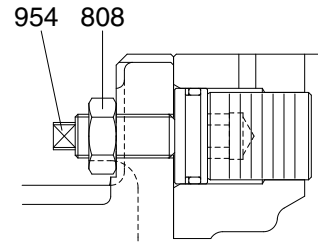

14W92MP23

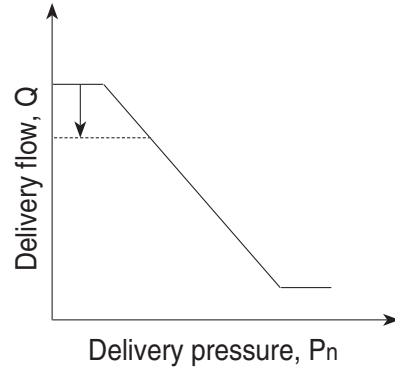

② Adjustment of minimum flow

Adjust it by loosening the hexagon nut (808) and by tightening (or loosening) the hexagonal socket head set screw (953). Similarly to the adjustment of the maximum flow, other characteristics are not changed.

However, remember that, if tightened too much, the required horsepower during the maximum delivery pressure (or during relieving) may increase.

Speed	Adjustment of min flow	
	Tightening amount of adjusting screw (953)	Flow change amount
(min ⁻¹)	(Turn)	(l/min)
2100	+1/4	+3.4

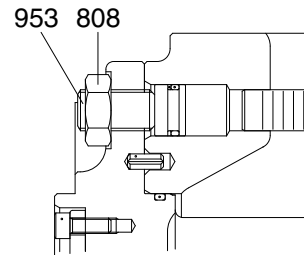

14W92MP24

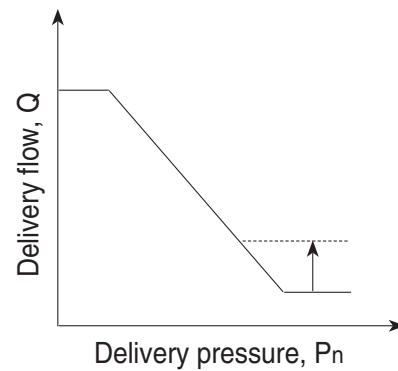

4) HOLDING VALVE OPERATION

(1) HOLDING OPERATION

At neutral condition, the pilot piston chamber is connected to drain port through the pilot port.

And the piston "B" is supported with spring "B".

Also, the pressured fluid from actuator entered to inside of the holding valve through the periphery hole of check, crevice of the check and the plug and the periphery hole of plug.

Then, this pressured oil pushed the poppet to the poppet seat and the check to the seat of body.

So the hydraulic fluid from actuator is not escaped and the actuator is not moved.

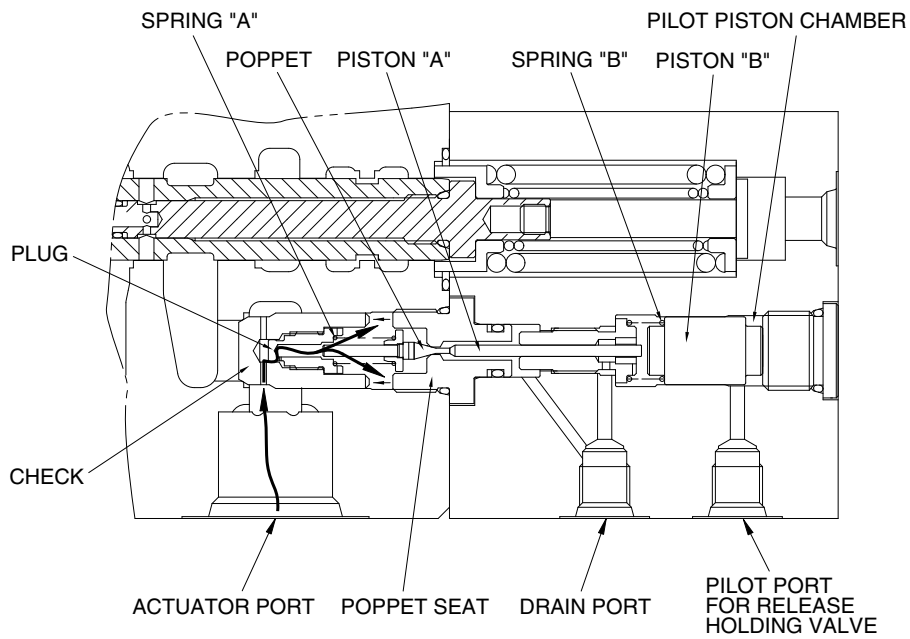

160WF2MC15

8) SWING PRIORITY FUNCTION

During swing priority operation, the pilot secondary pressure is supplied to the port Pc3 of the spring side of the swing priority spool and shift swing priority spool in the right direction.

The hydraulic fluid from P2 parallel passage flows into the parallel passage of arm 1 side through swing priority spool and the path "A" and also flows into the boom 2 spool.

When the swing priority spool is neutral condition, the passage is same as normal condition. But due to shifting of the swing priority spool, the fluid from pump A1 flows to swing side more then the boom 2, arm 1, option B and dozer spools to make the swing operation most preferential.

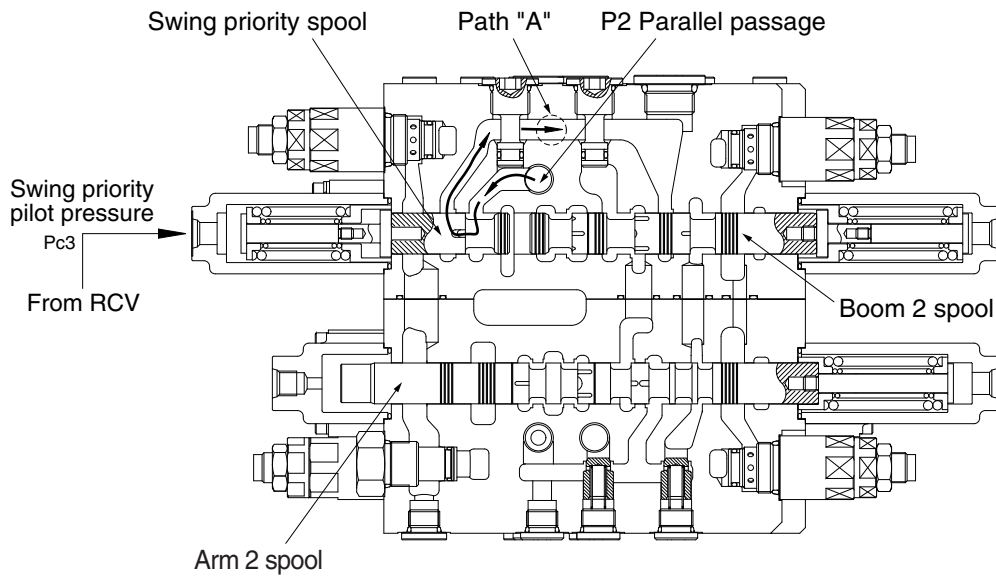

1609A2MC27

2) REDUCTION GEAR

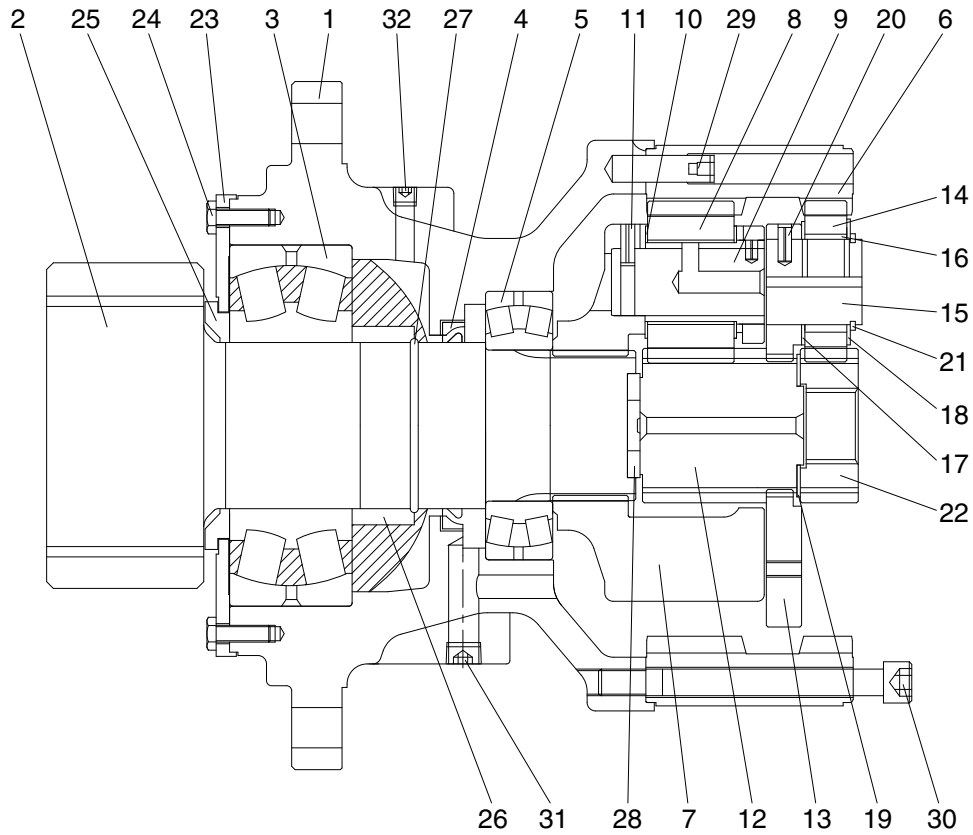

160F2SM05

1	Casing	12	Sun gear 2	23	Cover plate
2	Drive shaft	13	Carrier 1	24	Hexagon bolt
3	Roller bearing	14	Planet gear 1	25	Spacer
4	Oil seal	15	Pin 1	26	Spacer pipe
5	Roller bearing	16	Needle cage	27	Wire
6	Ring gear	17	Side plate 1	28	Thrust plate
7	Carrier 2	18	Side plate 2	29	Knock pin
8	Planet gear 2	19	Side plate 3	30	Socket bolt
9	Pin 2	20	Spring pin	31	Plug
10	Thrust washer	21	Stop ring	32	Plug
11	Spring pin	22	Sun gear 1		

1) SWING MOTOR

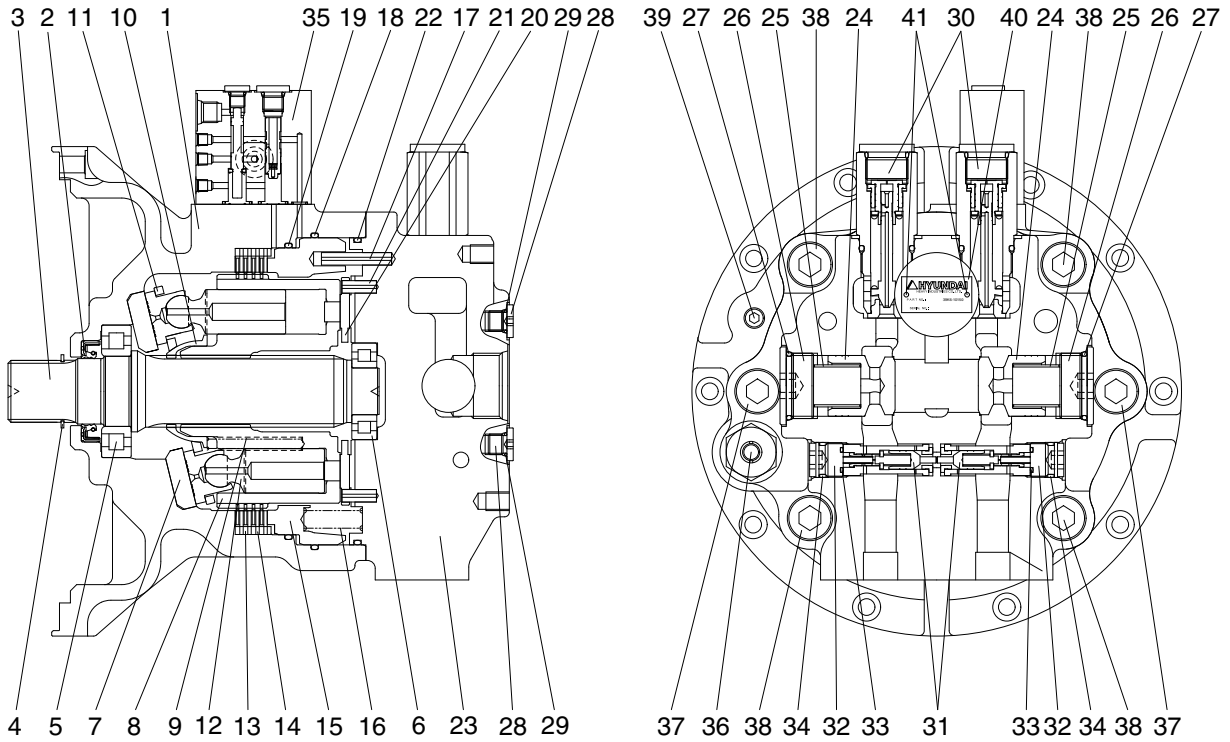

220L2SM02

- | | | |
|-------------------|-------------------|----------------------------|
| 1 Casing | 15 Parking piston | 29 O-ring |
| 2 Oil seal | 16 Brake spring | 30 Relief valve assy |
| 3 Shaft | 17 Spring pin | 31 Reactionless valve assy |
| 4 Snap ring | 18 O-ring | 32 Plug |
| 5 Roller bearing | 19 O-ring | 33 O-ring |
| 6 Needle bearing | 20 Valve plate | 34 O-ring |
| 7 Swash plate | 21 Spring pin | 35 Time delay valve assy |
| 8 Cylinder block | 22 O-ring | 36 Level gauge |
| 9 Spring | 23 Valve casing | 37 Socket bolt |
| 10 Ball guide | 24 Check valve | 38 Socket bolt |
| 11 Retainer plate | 25 Spring | 39 Plug |
| 12 Piston assy | 26 Plug | 40 Name plate |
| 13 Friction plate | 27 O-ring | 41 Rivet |
| 14 Separate plate | 28 Plug | |

GROUP 4 TRAVEL MOTOR

1. CONSTRUCTION

Travel motor consists motor unit, regulator and counter balance valve.

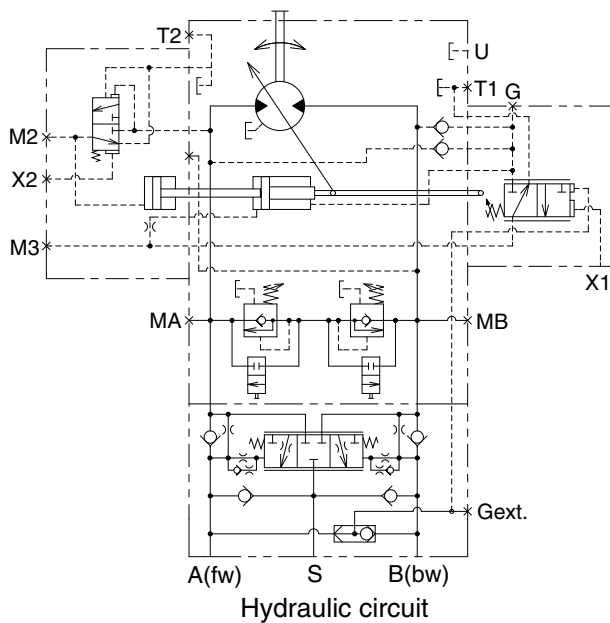
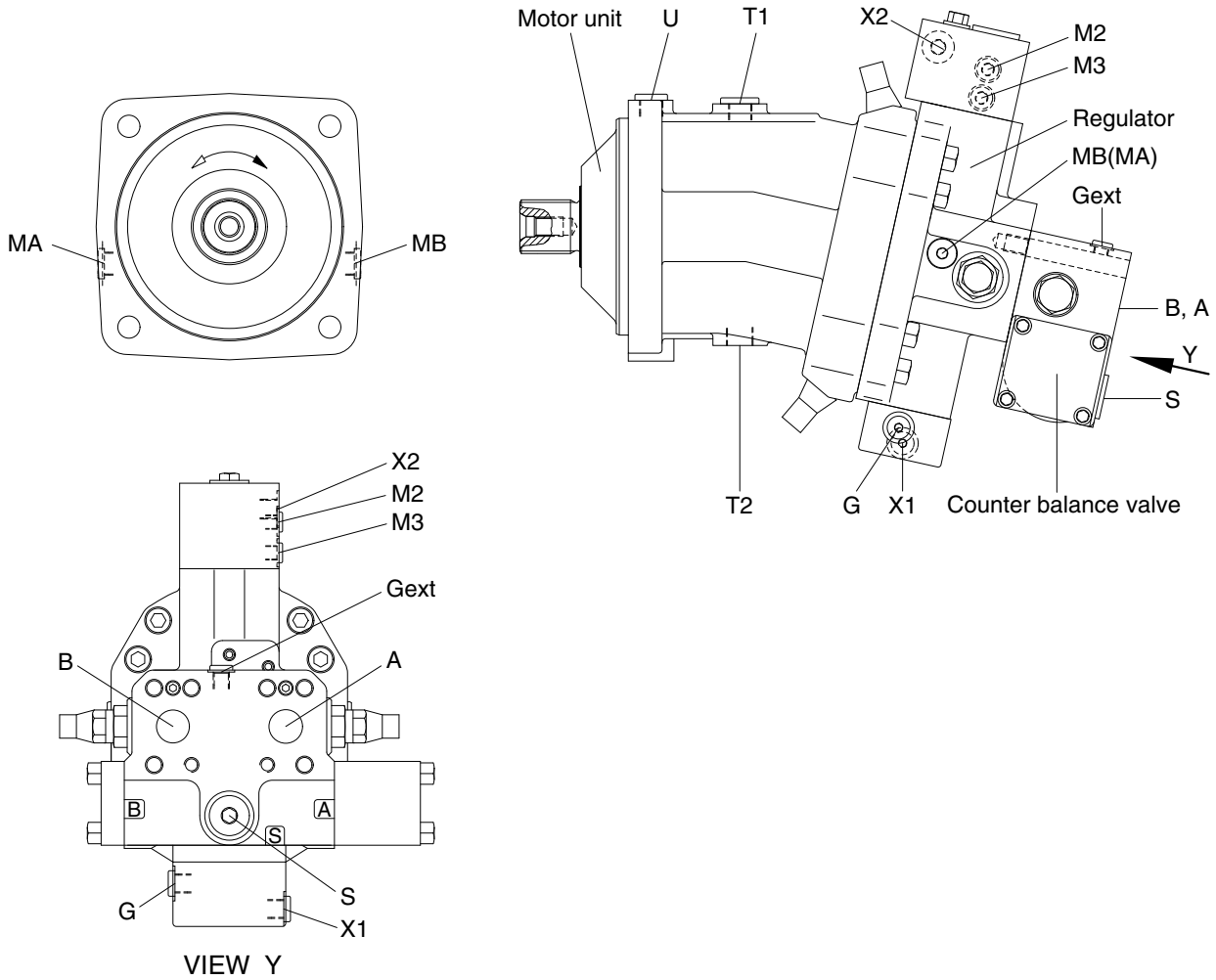

180W9A2TR01

Port	Port name	Port size
A, B	Main port	SAE 1 1/4"
G	N.A	M14 × 1.5 - 12
M1	Gauge port	M14 × 1.5 - 12
X1	Pilot pressure port	M14 × 1.5 - 12
X2	Pilot pressure port	M14 × 1.5 - 11.5
T1	Drain port	PF 3/4 - 17
T2	Drain port	PF 3/4 - 12
U	Flushing port	PF 1/2 - 16
S	Make up port	M27 × 2.0 - 16
MA, MB	Gauge port	M18 × 1.5 - 12
M2, M3	Gauge port	M10 × 1.0 - 8
Gext	Brake release port	M12 × 1.5 - 12.5

3) OPERATION

The operation of the pilot valve will be described on the basis of the hydraulic circuit diagram shown below and the attached operation explanation drawing.

The diagram shown below is the typical application example of the pilot valve.

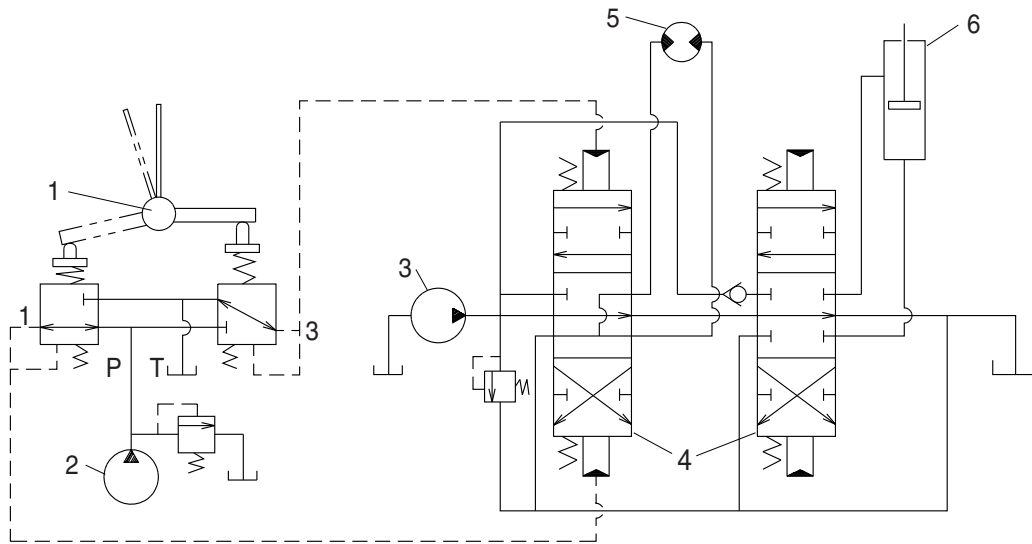

2-70

1 Pilot valve
2 Pilot pump

3 Main pump
4 Main control valve

5 Hydraulic motor
6 Hydraulic cylinder

3) HIGH SPEED (forward & reverse)

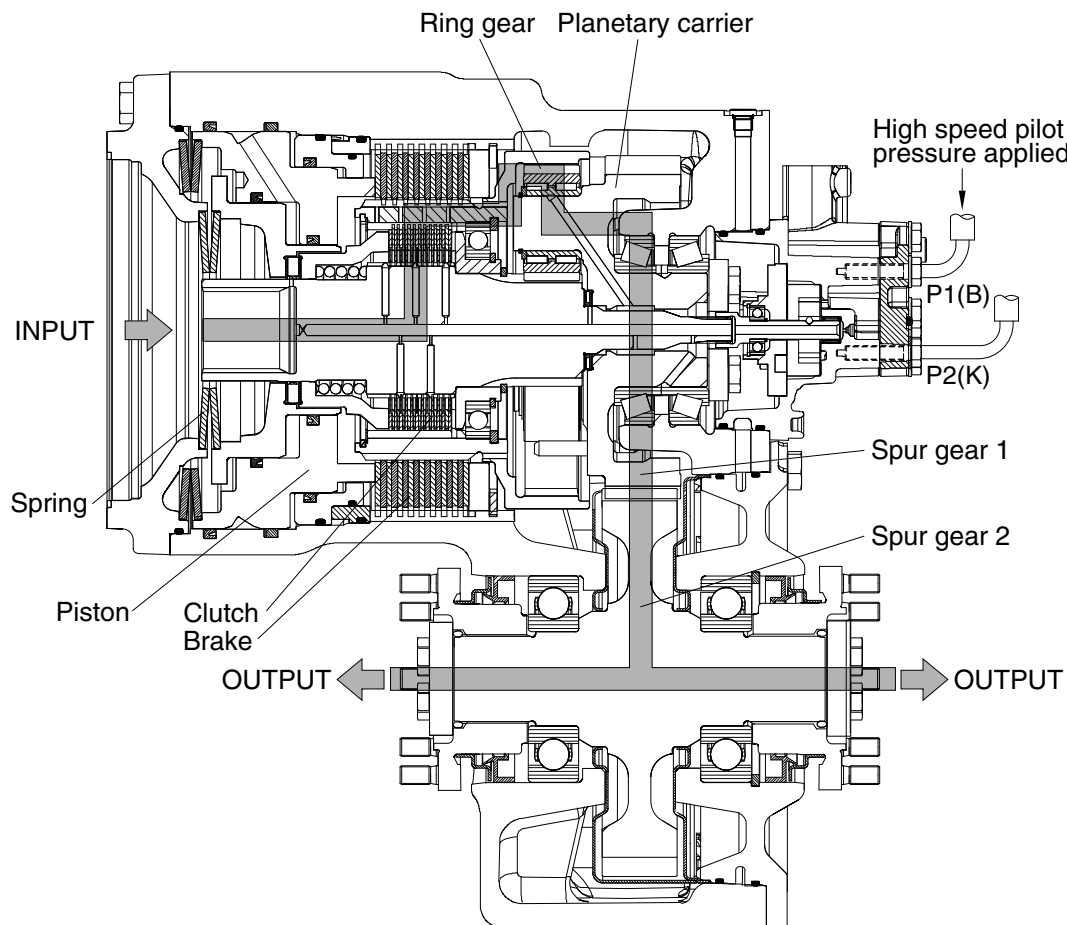

14W7A2TM05

In high speed operation, the clutch is held closed under spring pressure and the brake is hydraulically opened.

When a gear shift occurs-for example from high speed to low speed gear- the oil from the brake piston space is fed back to the tank through a restrictor (change over check valve) due to the spring pressure acting on the brake piston. At the same time the clutch is filled with oil and opened. Required oil flow is necessary for the transmission control to ensure the clutch is open before the brake begins to transmit torque.

A shift modulation valve is also integrated in the transmission. This modulates the pressure sequence at the brake during an upshift in order to achieve good shift quality.

The gear shift equipment also has the function of a parking brake. When the brake is operated-for example with high speed gear engaged-the clutch is closed and is statically loaded.

SECTION 3 HYDRAULIC SYSTEM

Group 1 Hydraulic Circuit	3-1
Group 2 Main Circuit	3-3
Group 3 Pilot Circuit	3-6
Group 4 Single Operation	3-17
Group 5 Combined Operation	3-32

4. SWING PARKING BRAKE RELEASE

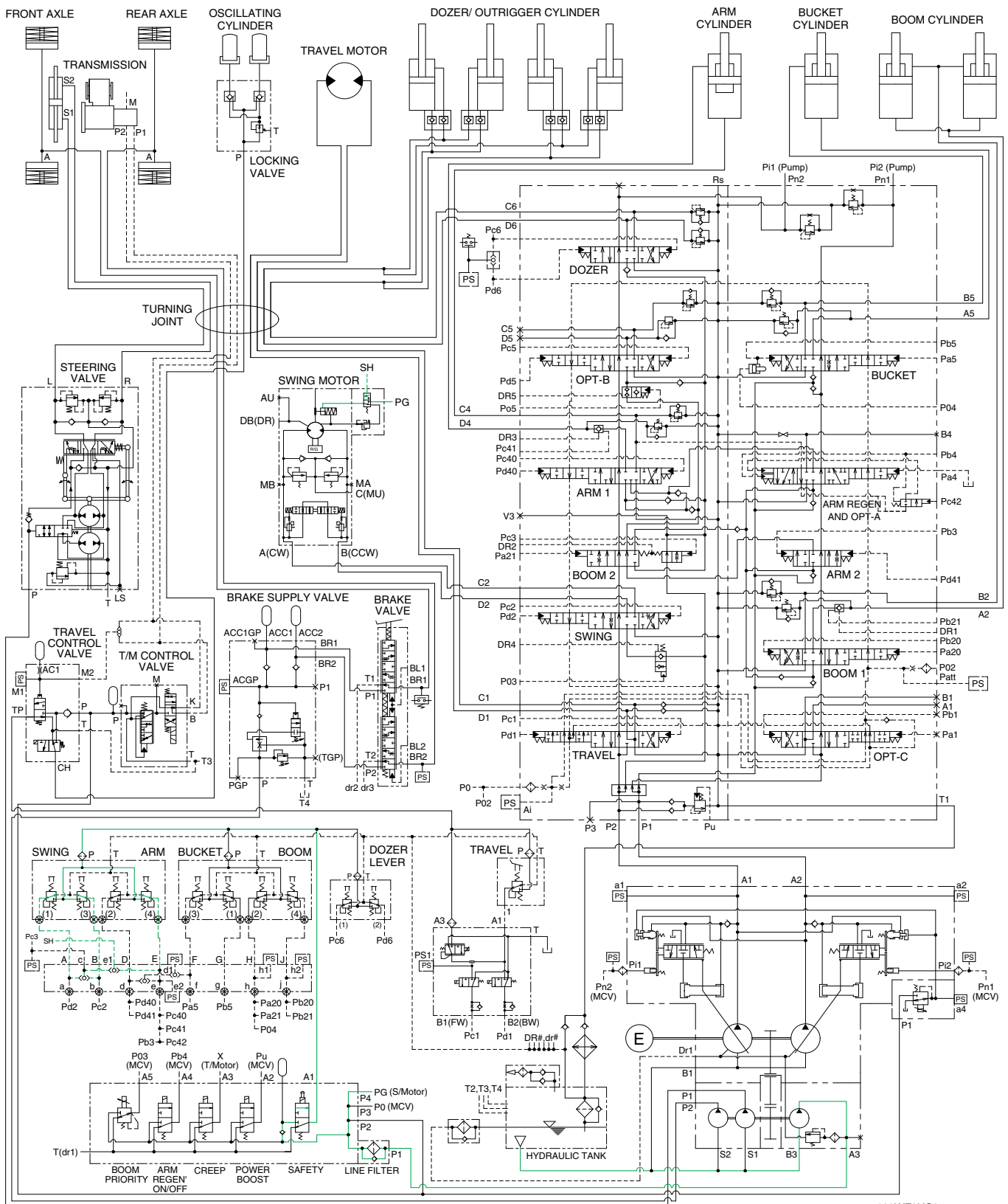

160WF3HC05

When the swing control lever or arm in control lever is tilted, the pilot oil flows into SH port through the terminal block. This pressure move spool so, discharged oil from pilot pump flows into swing motor PG port.

This pressure is applied to the parking piston of the swing motor, thus the brake released.

When the swing control lever and arm in control lever are set in the neutral position, oil in the chamber of the swing motor piston is drained, thus the brake is applied by the brake spring force.

4. ARM OUT OPERATION

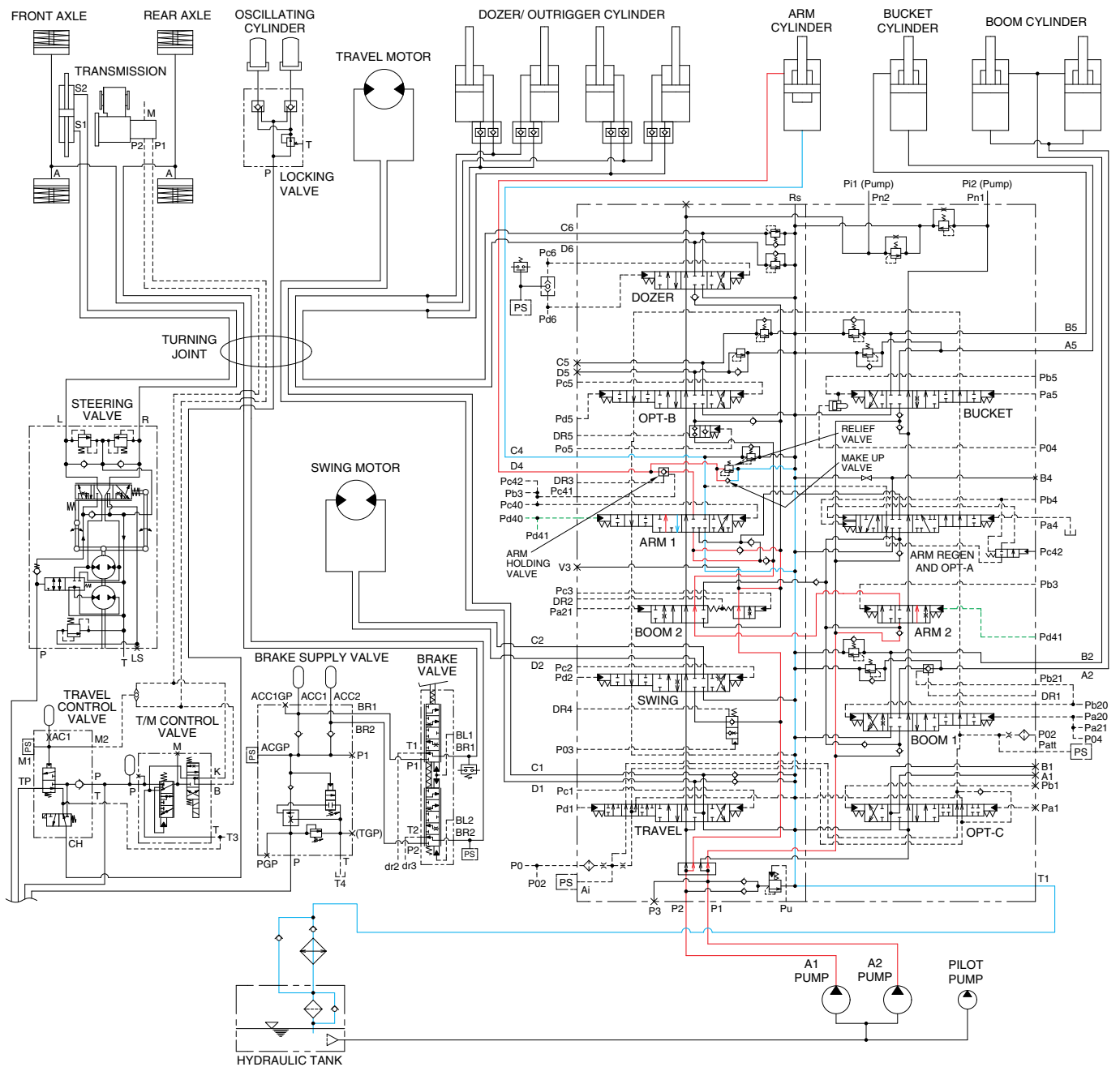

160WF3HC13

When the left control lever is pushed forward, the arm spools in the main control valve are moved to the arm out position by the pilot oil pressure from the remote control valve.

The oil from the A1 and A2 pump flows into the main control valve and then goes to the small chamber of arm cylinder. At the same time, the oil from the large chamber of arm cylinder returns to the hydraulic oil tank through the arm 1 spool in the main control valve. When this happens, the arm rolls out. The cavitation which will happen to the rod side of the arm cylinder is also prevented by the make-up valve in the main control valve. When the arm is roll out and the control lever is returned to neutral position, the circuit for the holding pressure at the rod side of the arm cylinder is closed by the arm holding valve. This prevent the hydraulic drift of arm cylinder.

12. STEERING CIRCUIT OPERATION

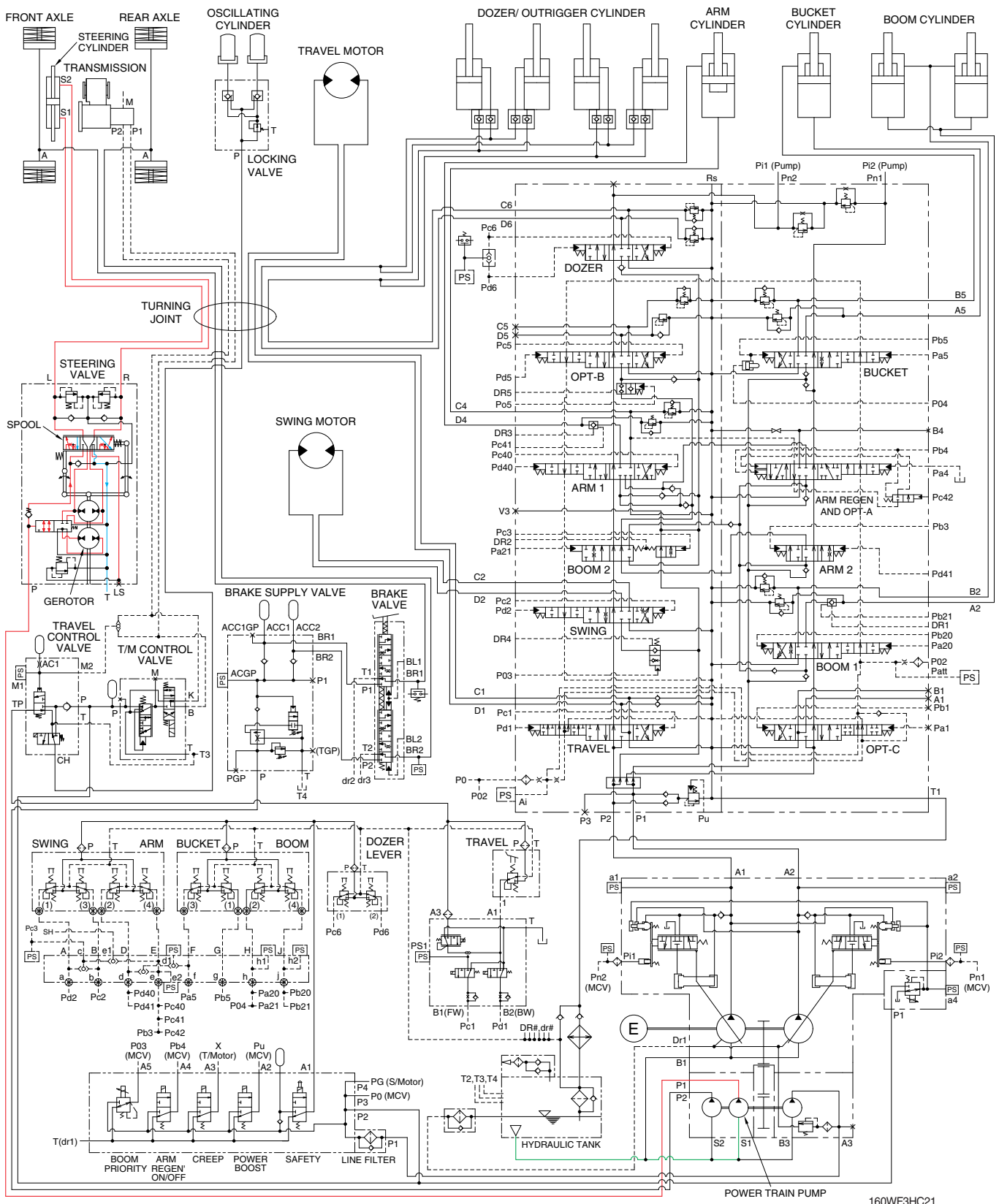

When the steering wheel is turned to the left or right, the spool within the steering valve turns left or right hand direction : Because the spool is connected with steering column.
 At this time, the oil discharged from the power train pump (P1) flows into steering cylinder through spool and gerotor within the steering valve and the turning joint.
 Then the steering direction is applied.

STARTING CIRCUIT

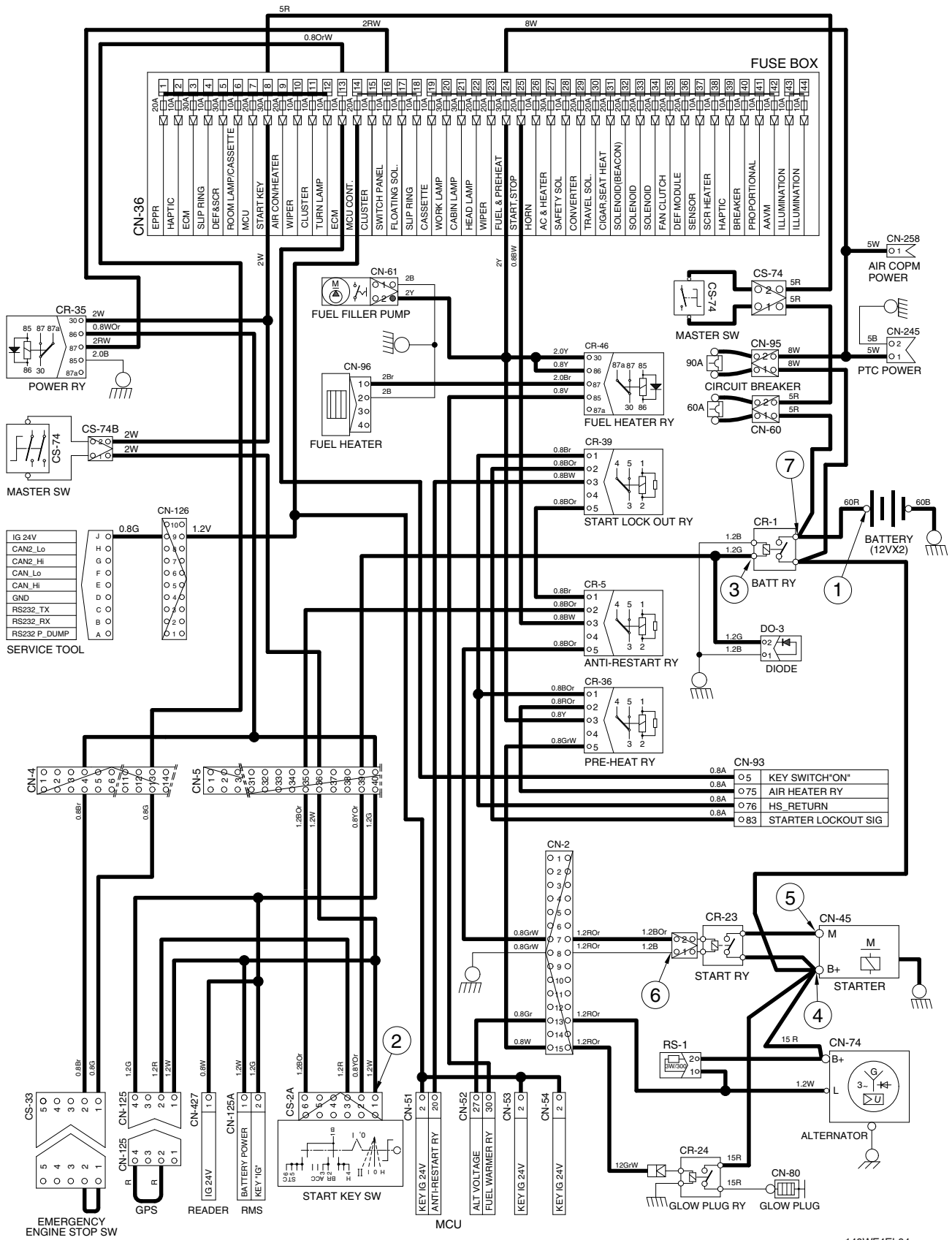



05	0.8A	KEY SWITCH*ON*
075	0.8A	AIR HEATER RY
076	0.8A	HS_RETURN
083	0.8A	STARTER LOCKOUT SIG

140WF4EL04

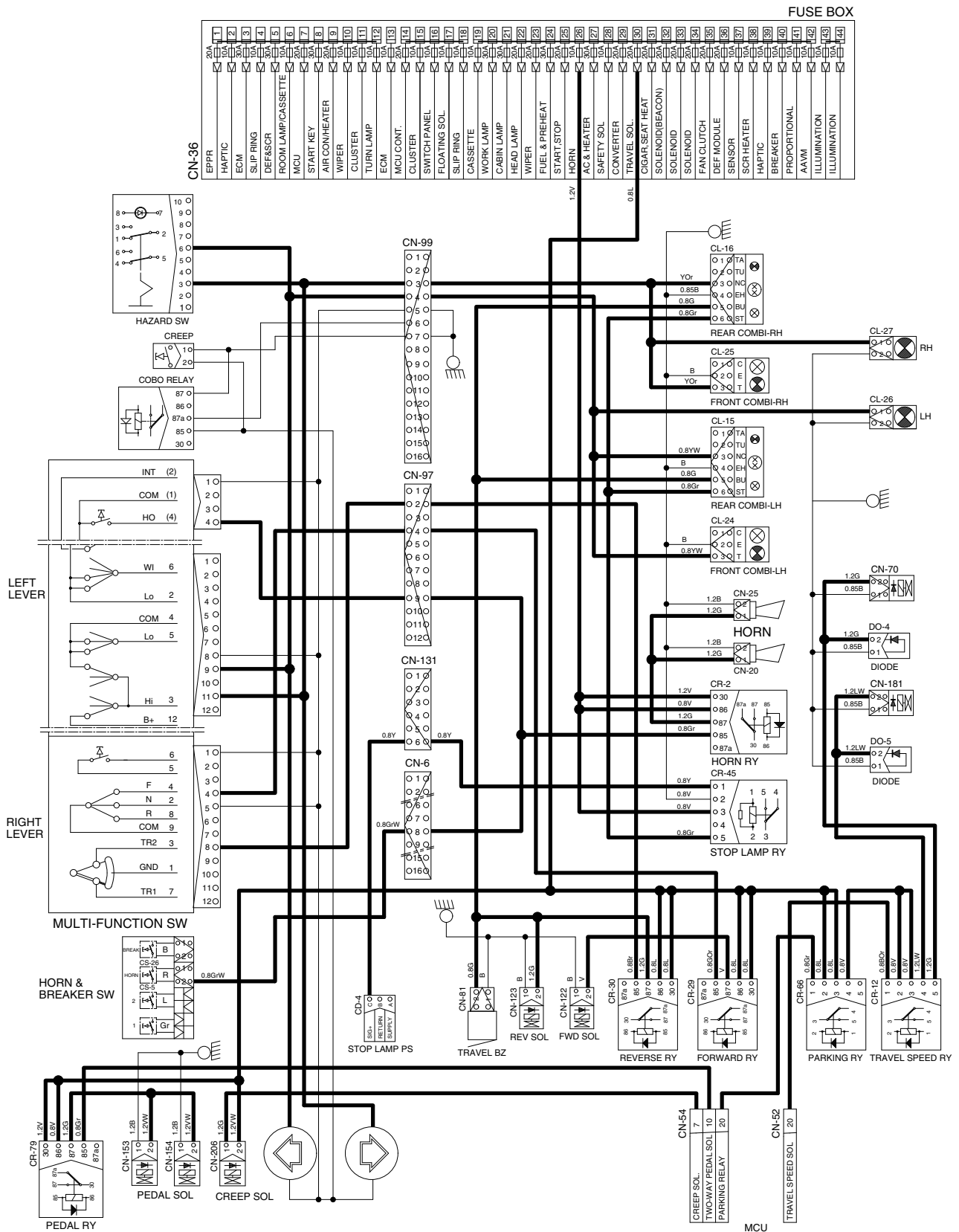
COMBINATION LAMP CIRCUIT

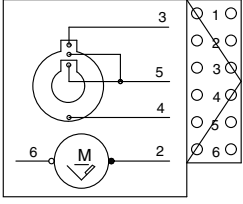
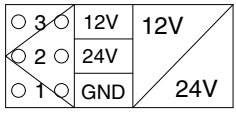
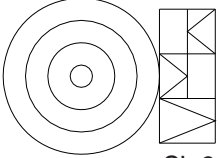
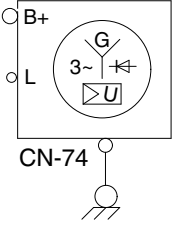

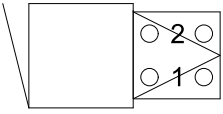
Part name	Symbol	Specifications	Check
Wiper motor	 <p>CN-21</p>	24V 2A	※ Check disconnection Normal : 7 Ω (for terminal 2-6)
DC/DC converter	 <p>CN-138</p>	12V 3A	※ Check voltage 24V (for terminal 1-2) 12V (for terminal 1-3)
Cigar lighter	 <p>CL-2</p>	24V 5A 1.4W	※ Check coil resistance Normal : About 1M Ω ※ Check contact Normal : ∞ Ω Operating time : 5~15sec
Alternator	 <p>CN-74</p>	Denso 24V 95A	※ Check contact Normal : 0 Ω (for terminal B ⁺ -L) Normal : 24~27.5V
Starter	 <p>CN-45</p>	Nippon denso 24V 4.8kW	※ Check contact Normal : 0.1 Ω
Travel alarm	 <p>CN-81</p>	24V 0.5A	※ Check contact Normal : 5.2 Ω

Connector number	Type	No. of pin	Destination	Connector part No.	
				Female	Male
CN-382	BOSCH	2	DEF/AdBlue® line heater 2	1-928-403-847	-
CN-383	BOSCH	2	DEF/AdBlue® line heater 3	1-928-403-847	-
CN-384	DEUTSCH	2	Coolant valve	DT06-2S-EP06	-
CN-385	-	7	Fan clutch	965570	-
CN-398	DEUTSCH	4	RS 232	DT04-4S-E005	DT06-4P-E005
CN-399	TYCO	-	DEF/AdBlue® tank level sensor	1-967325-1	-
CN-399	DEUTSCH	4	Service tool	-	DT04-4P-E005
CN-401	FCI	90	AAVM controller	A2C00021583	-
CN-402	DEUTSCH	6	Front view camera	DT06-6S-P021	DT04-6P-P021
CN-403	DEUTSCH	6	Rear view camera	-	DT04-6P-EP14
CN-404	DEUTSCH	6	Left view camera	-	DT04-6P-EP14
CN-405	DEUTSCH	6	Right view camera	-	DT04-6P-EP14
CN-406	DEUTSCH	3	RS 232	DT06-3S-EP06	DT04-3P-E005
CN-419	DEUTSCH	2	Swing parking A1	DT06-2S-EP06	-
CN-420	DEUTSCH	2	Swing parking A2	DT06-2S-EP06	-
CN-421	DEUTSCH	2	Swing parking A3	DT06-2S-EP06	-
CN-427	MOLEX	4	Reader	039012040	026013096
		12		5557-12R	5559-12P
CN-429	DELPHI	2	CAC out temperature	12162197	-
CN-430	DEUTSCH	6	l/conn (Side harness RH-Aftertreatment harness)	DT06-6S-EP06	DT06-6P-E005
CN-J7A	TYCO	4	DOC NOx sensor	2-1418390-1	-
CN-J7B	TYCO	4	SCR NOx sensor	1-1418390-1	-
CN-J10	TYCO	4	SCR thermistor	5-1418390-1	-
CN-J17	TYCO	4	DOC thermistor	4-1418390-1	-
CN-J31	BOSCH	2	DEF/AdBlue® dosing module	1_928_403_874	-
· Relay					
CR-1	RING-TERM	-	Battery relay	ST710289-2	-
CR-2	-	5	Horn relay	-	-
CR-4	-	5	Working lamp relay	-	-
CR-5	-	5	Anti restart relay	-	-
CR-7	-	5	Aircon compressor relay	-	-
CR-9	-	5	Cabin lamp relay	-	-
CR-11	AMP	3	Flasher unit relay	S810-003702	-
CR-12	-	5	Travel speed relay	-	-
CR-13	-	5	Head lamp low relay	-	-
CR-14	-	5	Head lamp high relay	-	-
CR-15	-	5	Illumination relay	-	-
CR-23	KET	2	Start relay	S814-002001	-
CR-24	RING TERM	1	Preheat relay	S822-014000	-

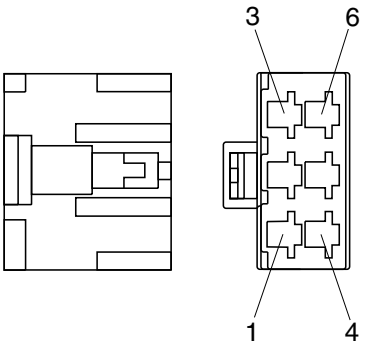
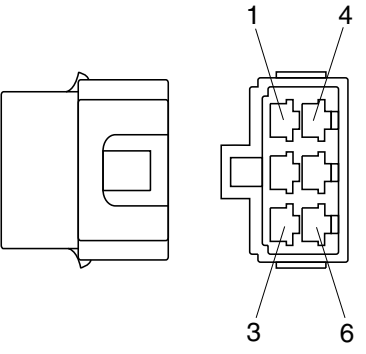
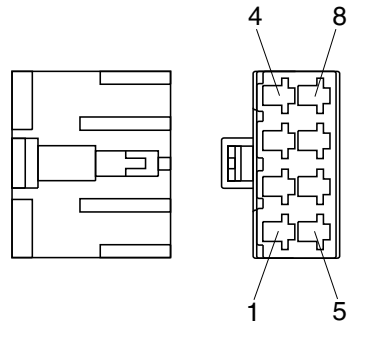
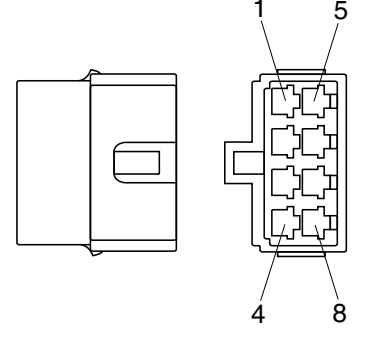
No. of pin	Receptacle connector (female)	Plug connector (male)
6	 <p data-bbox="686 645 837 678">S810-006202</p>	 <p data-bbox="1244 645 1396 678">S810-106202</p>
8	 <p data-bbox="686 1059 837 1093">S810-008202</p>	 <p data-bbox="1244 1059 1396 1093">S810-108202</p>

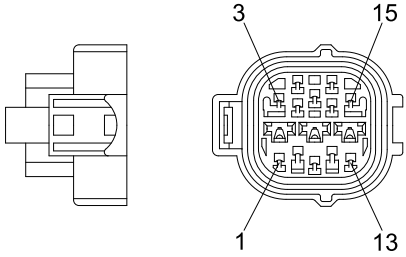
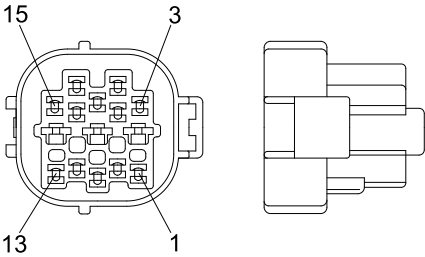
No. of pin	Receptacle connector (female)	Plug connector (male)
15	 <p data-bbox="730 636 836 667">368301-1</p>	 <p data-bbox="1278 636 1383 667">2-85262-1</p>

19) METRI-PACK TYPE CONNECTOR

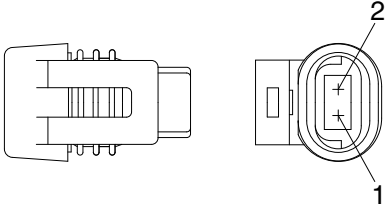
No. of pin	Receptacle connector (female)	Plug connector (male)
2	 <p data-bbox="730 1240 836 1272">12040753</p>	

20) DEUTSCH HD30 CONNECTOR

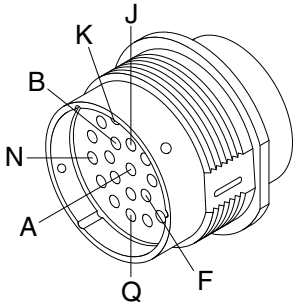
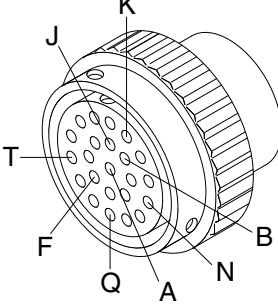
No. of pin	Receptacle connector (female)	Plug connector (male)
23	 <p data-bbox="667 1843 836 1874">HD36-24-23SN</p>	 <p data-bbox="1225 1843 1394 1874">HD34-24-23PN</p>

GROUP 4 POWER BOOST SYSTEM

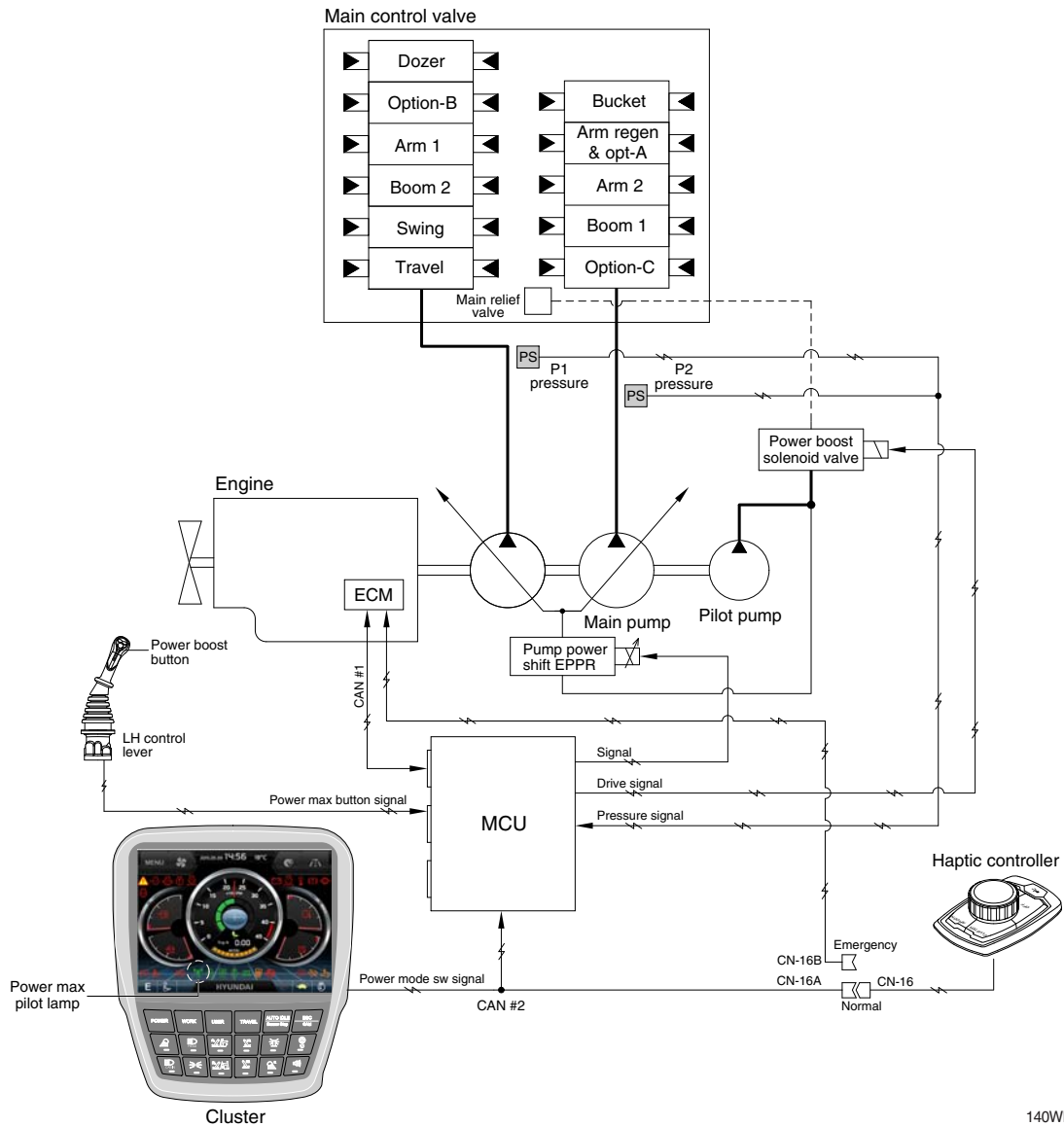

140WF5MS06

- When the power boost switch on the left control lever knob is pushed ON, the power mode is set P mode and maximum digging power is increased by 10 %.
- When the power boost function is activated, the power boost solenoid valve pilot pressure raises the set pressure of the main relief valve to increase the digging power.

Description	Condition	Function
Activated	Power boost switch : ON Accel dial : over 8	- Power mode : P - Accel dial power : 9 - Power boost solenoid : ON - Power boost pilot lamp : ON - Operating time : max 8 seconds
Canceled	Power boost switch : OFF	- Pre-set power mode - Power boost solenoid : OFF - Power boost pilot lamp : OFF

※ When the auto power boost is set to Enable and power mode is set to P mode on the cluster, the digging power is automatically increased as working conditions by the MCU. It is operated max 8 seconds.

GROUP 13 SELF-DIAGNOSTIC SYSTEM

1. OUTLINE

When any abnormality occurs in the ADVANCED CAPO system caused by electric parts malfunction and by open or short circuit, the MCU diagnoses the problem and sends the error codes to the cluster and also stores them in the memory.

2. MONITORING

1) Active fault



- The active faults of the MCU, engine ECM or air conditioner can be checked by this menu.

2) Logged fault



- The logged faults of the MCU, engine ECM or air conditioner can be checked by this menu.

3) Delete logged fault



- The logged faults of the MCU, engine ECM or air conditioner can be deleted by this menu.

DTC		Diagnostic Criteria	Application		
HCESPN	FMI		G	C	W
169	4	Monitor – Selecting attachment(breaker / crusher) (Detection) (When Attachment Conflux Solenoid is Off) 10 seconds continuous, Attachment Conflux Solenoid drive unit Measurement Voltage $\leq 3.0V$ (Cancellation) (When Attachment Conflux Solenoid is Off) 3 seconds continuous, Attachment Conflux Solenoid drive unit Measurement Voltage $> 3.0V$	●		
	6	(Detection) (When Attachment Conflux Solenoid is On) 10 seconds continuous, Attachment Conflux Solenoid drive Current $> 6.5 A$ (Cancellation) (When Attachment Conflux Solenoid is On) 3 seconds continuous, Attachment Conflux Solenoid drive Current $\leq 6.5 A$	●		
(Results / symptoms) 1. Control Function – Option attachment flow control – Joining operation failure (Eco breaker mode, crusher mode) (Checking list) 1. CD-237 (#1) – CN-53 (#7) Checking Open/Short 2. CD-237 (#2) – CR-35 (#87) Checking Open/Short					
170	4	(Model Parameter) mounting Arm Regenerating Solenoid (Detection) (When Arm Regeneration Solenoid is Off) 10 seconds continuous, Arm Regeneration Solenoid drive unit Measurement Voltage $\leq 3.0V$ (Cancellation) (When Arm Regeneration Solenoid is Off) 3 seconds continuous, Arm Regeneration Solenoid drive unit Measurement Voltage $> 3.0V$	●		
	6	(Detection) (When Arm Regeneration Solenoid is On) 10 seconds continuous, Arm Regeneration Solenoid drive current $> 4.5 A$ (Cancellation) (When Arm Regeneration Solenoid is On) 3 seconds continuous, Arm Regeneration Solenoid drive current $\leq 4.5 A$	●		
(Detection) (When Arm Regeneration Solenoid is On) 10 seconds continuous, Arm Regeneration Solenoid drive current $> 4.5 A$ (Cancellation) (When Arm Regeneration Solenoid is On) 3 seconds continuous, Arm Regeneration Solenoid drive current $\leq 4.5 A$					

※ Some error codes are not applied to this machine.

G : General

C : Crawler Type

W : Wheel Type

DTC		Diagnostic Criteria	Application		
HCESPN	FMI		G	C	W
530	0	10 seconds continuous, Travel Forward Press. Sensor Measurement Voltage > 5.2V			●
	1	10 seconds continuous, 0.3V ≤ Travel Forward Press. Sensor Measurement Voltage < 0.8V			●
	4	10 seconds continuous, Travel Forward Press. Sensor Measurement Voltage < 0.3V			●
	(Results / Symptoms) 1. Monitor – Travel Forward Press. display failure 2. Control Function – Driving interoperability power control operation failure (Checking list) 1. CD-73 (#B) – CN-54 (#6) Checking Open/Short 2. CD-73 (#A) – CN-54 (#3) Checking Open/Short 3. CD-73 (#C) – CN-54 (#13) Checking Open/Short				
531	1	10 seconds continuous, 0.3V ≤ Travel Reverse Press. Sensor Measurement Voltage < 0.8V			●
	4	10 seconds continuous, Travel Reverse Press. Sensor Measurement Voltage < 0.3V			●
	(Results / Symptoms) 1. Monitor – Travel Reverse Press. display failure 2. Control Function – Driving interoperability power control operation failure (Checking list) 1. CD-74 (#B) – CN-54 (#23) Checking Open/Short 2. CD-74 (#A) – CN-54 (#3) Checking Open/Short 3. CD-74 (#C) – CN-54 (#13) Checking Open/Short				
705	0	10 seconds continuous, Battery input Voltage > 35V	●		
	1	10 seconds continuous, Battery input Voltage < 18V	●		
	(Results / Symptoms) 1. Control Function – Startup impossibility (Checking list) 1. CS-74A (#1) – CN-51 (#1) Checking Open/Short				
707	1	(When Engine is equal or more than 400 rpm) 10 seconds continuous, Alternator Node L Measurement Voltage < 18V (In case 12v goods, Alternator Node L Measurement Voltage < 9V)	●		
	(Results / Symptoms) 1. Control Function – Battery charging circuit failure (Checking list) 1. CS-74A (#1) – CN-51 (#2) Checking Open/Short				

※ Some error codes are not applied to this machine.

G : General

C : Crawler Type

W : Wheel Type

Fault code J1939 SPN J1939 FMI	Reason	Effect (only when fault code is active)
559 157 18	Injector metering rail 1 pressure - Data valid but below normal operational range - Moderately severe level. The ECM has detected that fuel pressure is lower than commanded pressure.	Possibly hard to start or low power. Engine could possibly not start.
584 677 3	Starter relay driver circuit - Voltage above normal, or shorted to high source. Open circuit or high voltage detected at starter lockout circuit.	Either the engine will not start or the engine will not have starter lockout protection.
585 677 4	Starter relay driver circuit - Voltage below normal, or shorted to low source. Low voltage detected at starter lockout circuit.	Either the engine will not start or the engine will not have starter lockout protection.
595 103 16	Turbocharger 1 speed - Data valid but above normal operating range - Moderately severe level. High turbocharger speed has been detected by the ecm.	Engine power derate.
596 167 16	Electrical charging system voltage - Data valid but above normal operational range - Moderately severe level. High battery voltage detected by the battery voltage monitor feature.	None on performance.
597 167 18	Electrical charging system voltage - Data valid but below normal operational range - Moderately severe level. Low battery voltage detected by the battery voltage monitor feature.	None on performance.
649 1378 31	Engine oil change interval - Condition exists. Change engine oil and filter.	None on performance.
687 103 18	Turbocharger 1 speed - Data valid but below normal operational range - Moderately severe level. Low turbocharger speed detected by the ECM.	Engine power derate. The ECM uses an estimated turbocharger speed.
689 190 2	Engine crankshaft speed/position - Data erratic, intermittent, or incorrect. The ECM has detected an error in the engine speed signal.	Possible reduced engine performance.
691 1172 3	Turbocharger 1 compressor inlet temperature sensor circuit - Voltage above normal, or shorted to high source. High signal voltage detected at turbocharger compressor inlet air temperature circuit.	Engine power derate.
692 1172 4	Turbocharger 1 compressor inlet temperature circuit - Voltage below normal, or shorted to low source. Low signal voltage detected at turbocharger compressor inlet air temperature circuit.	Engine power derate.
693 1172 2	Turbocharger 1 compressor intake temperature - Data erratic, intermittent, or incorrect. A temperature too high or low for the operating conditions has been detected by the turbocharger compressor intake temperature sensor.	Possible reduced engine performance.

※ Some fault codes are not applied to this machine.

Fault code J1939 SPN J1939 FMI	Reason	Effect (only when fault code is active)
3165 4363 0	Aftertreatment SCR outlet temperature - Data valid but above normal operational range - Most severe level. The SCR outlet temperature sensor reading has exceeded the maximum engine protection temperature limit.	Possible reduced engine performance.
3168 3936 16	Aftertreatment diesel particulate filter system - Data valid but above normal operating range - Moderately severe level. The system has detected a malfunction in the filtering capability of the aftertreatment diesel particulate filter.	None on performance.
3186 1623 9	Tachograph output shaft speed - Abnormal update rate. No communication or an invalid data transfer rate has been detected on the J1939 data link between the ECM and the tachograph output shaft speed sensor.	None on performance.
3213 1623 19	Tachograph output shaft speed - Received network data in error. The J1939 multiplexing controller has indicated a malfunction of the tachograph output shaft speed sensor.	None on performance.
3228 3216 2	Aftertreatment Intake NOx sensor - Data erratic, intermittent, or incorrect. An incorrect NOx sensor reading has been detected by the aftertreatment intake NOx sensor.	Possible reduced engine performance.
3232 3216 9	Aftertreatment Intake NOx sensor - Abnormal update rate. No communication or an invalid data transfer rate has been detected on the J1939 data link between the ECM and the aftertreatment intake NOx sensor.	Possible reduced engine performance.
3235 4363 16	Aftertreatment SCR outlet temperature - Data valid but above normal operating range - Moderately severe level. The SCR outlet temperature sensor reading has exceeded the maximum temperature limit.	Possible reduced engine performance.
3237 4340 3	Aftertreatment diesel exhaust fluid line heater 1 circuit - Voltage above normal or shorted to high source. High signal voltage detected at the diesel exhaust fluid line heater 1 circuit.	Possible reduced engine performance.
3238 4340 4	Aftertreatment diesel exhaust fluid line heater 1 circuit - Voltage below normal, or shorted to low source. Low signal voltage detected at the diesel exhaust fluid line heater 1 circuit.	Possible reduced engine performance.
3239 4342 3	Aftertreatment diesel exhaust fluid line heater 2 circuit - Voltage above normal or shorted to high source. High signal voltage detected at the diesel exhaust fluid line heater 2 circuit.	Possible reduced engine performance.
3241 4342 4	Aftertreatment diesel exhaust fluid line heater 2 circuit - Voltage below normal, or shorted to low source. Low signal voltage detected at the diesel exhaust fluid line heater 2 circuit.	Possible reduced engine performance.

※ Some fault codes are not applied to this machine.

Fault code J1939 SPN J1939 FMI	Reason	Effect (only when fault code is active)
4149 2623 8	Accelerator pedal or lever position sensor 2 circuit frequency - Abnormal frequency or pulse width or period. The accelerator pedal position sensor reading is out of range.	The engine will operate in Limp Home mode.
4151 5742 9	Aftertreatment diesel particulate filter temperature sensor module - Abnormal update rate. No communications on the J1939 data link between the ECM and the aftertreatment diesel particulate filter temperature sensor module.	Possible reduced engine performance.
4152 5743 9	Aftertreatment selective catalytic reduction temperature sensor module - Abnormal update rate. No communications on the J1939 data link between the ECM and the aftertreatment SCR temperature sensor module.	Possible reduced engine performance.
4155 5746 3	Aftertreatment 1 diesel exhaust fluid dosing unit heater relay - Voltage above normal, or shorted to high source. High signal voltage detected at the aftertreatment diesel exhaust fluid dosing unit heater relay circuit.	Possible reduced engine performance.
4156 5746 4	Aftertreatment 1 diesel exhaust fluid dosing unit heater relay - Voltage below normal, or shorted to low source. Low signal voltage detected at the aftertreatment diesel exhaust fluid dosing unit heater relay circuit.	Possible reduced engine performance.
4157 4376 7	Aftertreatment diesel exhaust fluid return valve - Mechanical system not responding or out of adjustment. A stuck aftertreatment diesel exhaust fluid return valve has been detected.	None on performance.
4158 5742 12	Aftertreatment diesel particulate filter temperature sensor module - Bad intelligent device or component. An internal error has been detected in the aftertreatment diesel particulate filter temperature sensor module.	Possible reduced engine performance.
4159 5743 12	Aftertreatment selective catalytic reduction temperature sensor module - Bad intelligent device or component. An internal error has been detected in the aftertreatment SCR temperature sensor module.	Possible reduced engine performance.
4161 5742 3	Aftertreatment diesel particulate filter temperature sensor module - Voltage above normal, or shorted to high source. High battery supply voltage detected at the aftertreatment diesel particulate filter temperature sensor module.	Possible reduced engine performance.
4162 5742 4	Aftertreatment diesel particulate filter temperature sensor module - Voltage below normal, or shorted to low source. Low battery supply voltage detected at the aftertreatment diesel particulate filter temperature sensor module.	Possible reduced engine performance.

※ Some fault codes are not applied to this machine.

2. BOOM PRIORITY EPPR VALVE

1) COMPOSITION

The boom priority EPPR valve is built in a manifold and mainly consisting of valve body and coil. This EPPR valve installed under the solenoid valve.

2) CONTROL

The boom priority EPPR valve has to be controlled by a specific electronic amplifier card, which is supplying the coil with a current 580 mA at 30Ω and 24 V.

3) OPERATING PRINCIPLE

(1) Structure

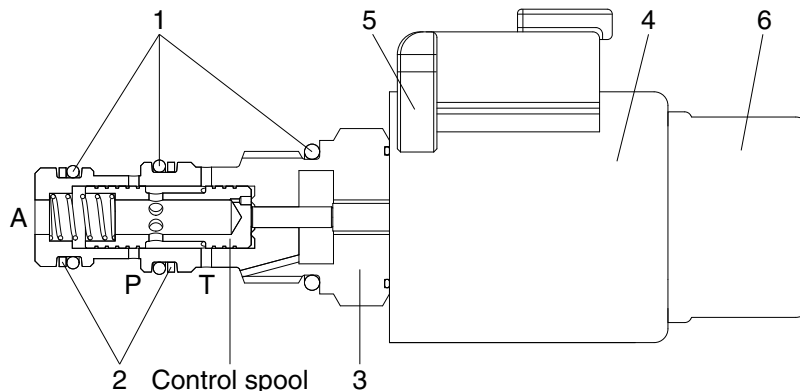

21095MS14

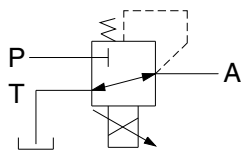

P : Pilot supply line
T : Return to tank
A : Secondary pressure to flow MCV

- | | | | | | |
|---|--------------|---|------------|---|-----------|
| 1 | O-ring | 3 | Valve body | 5 | Connector |
| 2 | Support ring | 4 | Coil | 6 | Cover cap |

(2) Operation

In de-energized mode the inlet port (P) is closed and the outlet port (A) is connected to tank port (T).

In energized mode the solenoid armature presses onto the control spool with a force corresponding to the amount of current. This will set a reduced pressure at port A. The setting is proportional to the amount of current applied.

(3) Maximum pressure relief

If a pressure from outside is applied on port A the valve may directly switch to tank port (T) and protect the system before overload.

(5) Engine oil pressure warning lamp

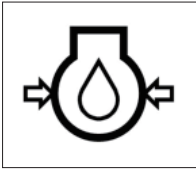

290F3CD65

- ① This warning lamp pops up and the buzzer sounds when the engine oil pressure is low.
- ② If the lamp blinks, shut OFF the engine immediately. Check oil level.

(6) Engine coolant low level warning lamp

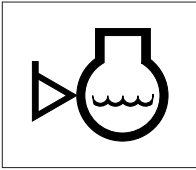

760F3CD58

- ① This warning lamp pops up and the buzzer sounds when the level of coolant is low.
- ② Fill the coolant immediately when the lamp is ON.

(7) Check engine warning lamp



290F3CD66

- ① This warning lamp pops up and the buzzer sounds when the communication between MCU and engine ECM on the engine is abnormal, or if the cluster received specific fault code from engine ECM.
- ② Check the communication line between them.
If the communication line is OK, then check the fault codes on the cluster.

(8) Engine stop warning lamp



※ Refer to page 5-72.

※ Refer to page 5-70.

※ Please contact your HD Hyundai Construction Equipment service center or local dealer.

(9) Battery charging warning lamp

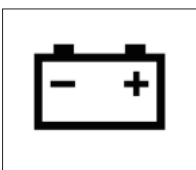

290F3CD67

- ① This warning lamp pops up and the buzzer sounds when the battery charging voltage is low.
- ② Check the battery charging circuit when this lamp blinks.

(8) Head lamp switch

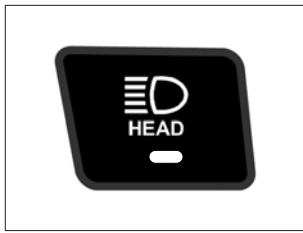

This switch is used to operate the head lamp.
The pilot lamp is turned ON when operating the switch.

(9) Front left outrigger/Front dozer switch



This switch is used to select the front left outrigger or front dozer blade operation.

The pilot lamp is turned ON when operating the switch.

Please check the installed equipment (outrigger or dozer) on your machine before selecting the switch.

Refer to the operator's manual page 3-49 for the dozer and outrigger lever.

(10) Front right outrigger switch



Refer to the operator's manual page 3-49 for the dozer and outrigger lever.

(11) Rear left outrigger/Rear dozer switch



Please check the installed equipment (outrigger or dozer) on your machine before selecting the switch.

Refer to the operator's manual page 3-49 for the dozer and outrigger lever.

(12) Rear right outrigger switch



Refer to the operator's manual page 3-49 for the dozer and outrigger lever.

③ Machine security



210WF3CD190



210WF3CD135



210WF3CD136



210WF3CD137



210WF3CD138

· ESL mode setting

- ESL : Engine Starting Limit
- ESL mode is designed to be a theft deterrent or will prevent the unauthorized operation of the machine.
- If the ESL mode was selected Enable, the password will be required when the start switch is turned ON.

- Machine security

Disable : Not used ESL function

Enable (always) : The password is required whenever the operator starts engine.

- **Interval** : The password is required when the operator starts engine first. But the operator can restart the engine within the interval time without inputting the password.

The interval time can be set maximum 4 hours.

※ **Default password** : 00000 + ✓

※ **Password length** : (5~10 digit) + ✓

- **Smart key** (option) : Smart key is registered when equipped with optional smart key. If smart key is not inside of the cabin, authentication process fails and the password entering is needed.

· Password change

- The password is 5~10 digits.



210WF3CD190



210WF3CD140



210WF3CD135

Enter the current password



210WF3CD142

Enter the new password



210WF3CD143

Enter the new password again

(6) Fan speed switch

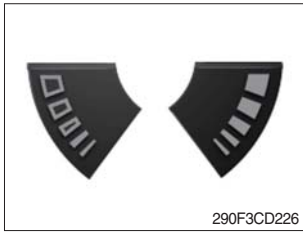

- ① Fan speed is controlled automatically by setted temperature.
- ② This switch controls fan speed manually.
 - There are 8 up/down steps to control fan speed.
 - The maximum step or the minimum step beeps 5 times.

(7) Fan speed

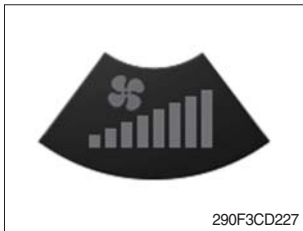

- ① Steps 1 through 8 to display the amount of wind.

(8) Fresh air/air recirculation switch



- ① It is possible to change the air-inlet method.
 - a. **Fresh air** (☞)
 - Inhaling air from the outside.
 - b. **Air recirculation** (☞)
 - It recycles the heated or cooled air to increase the energy efficiency.
- ※ **Change air occasionally when using recirculation for a long time.**
- ※ **Check out the fresh air filter and the recirculation filter periodically to keep a good efficiency.**

(9) Air mode switch



- ① Operating this switch, it beeps and displays symbol of each mode in order. (Face → Face/Rear → Face/Rear/Foot → Foot → Def/Foot)

Mode switch	Face	Face/Rear	Face/Rear/Foot	Foot	Def/Foot
Outlet	A	●	●	●	
	B		●	●	
	C			●	●
	D				●

- ② When defroster mode operating, FRESH AIR/AIR RECIRCULATION switch turns to FRESH AIR mode and air conditioner switch turns ON.

3. HYDRAULIC SYSTEM

1) HYDRAULIC OIL IS CLOUDY

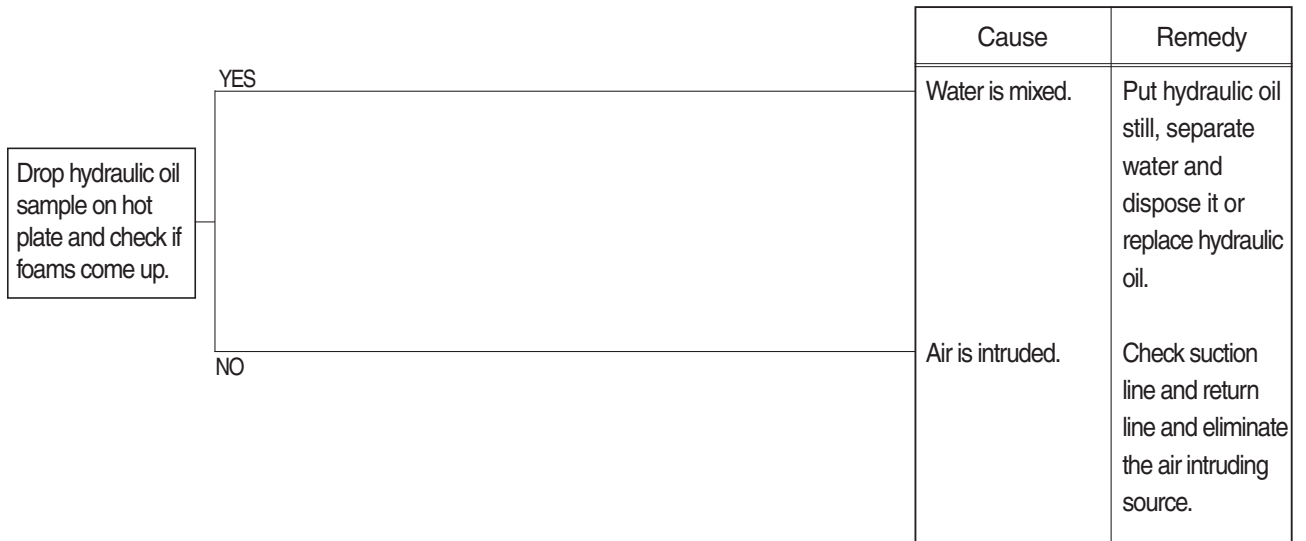

2) HYDRAULIC OIL TEMPERATURE HAS RISEN ABNORMALLY

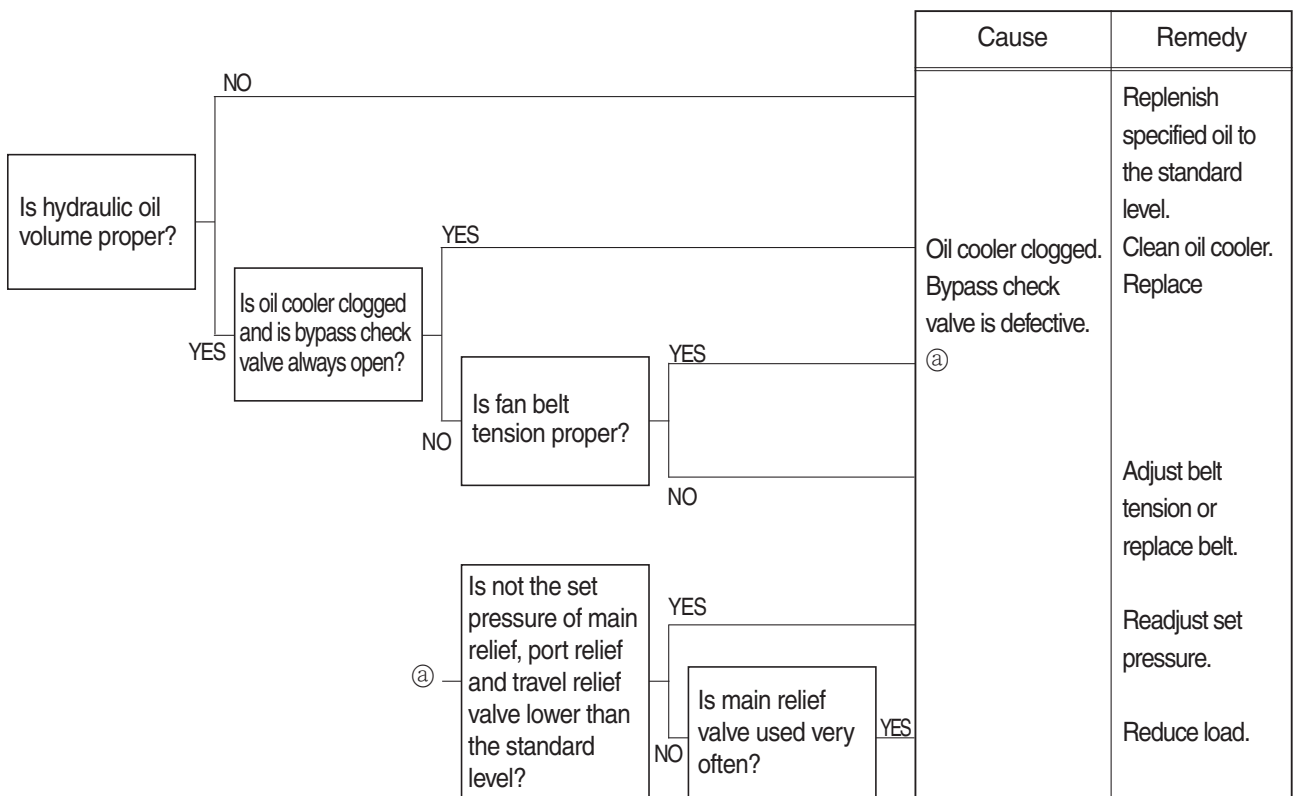

6. ATTACHMENT SYSTEM

1) BOOM OR ARM ACTION IS IMPOSSIBLE AT ALL

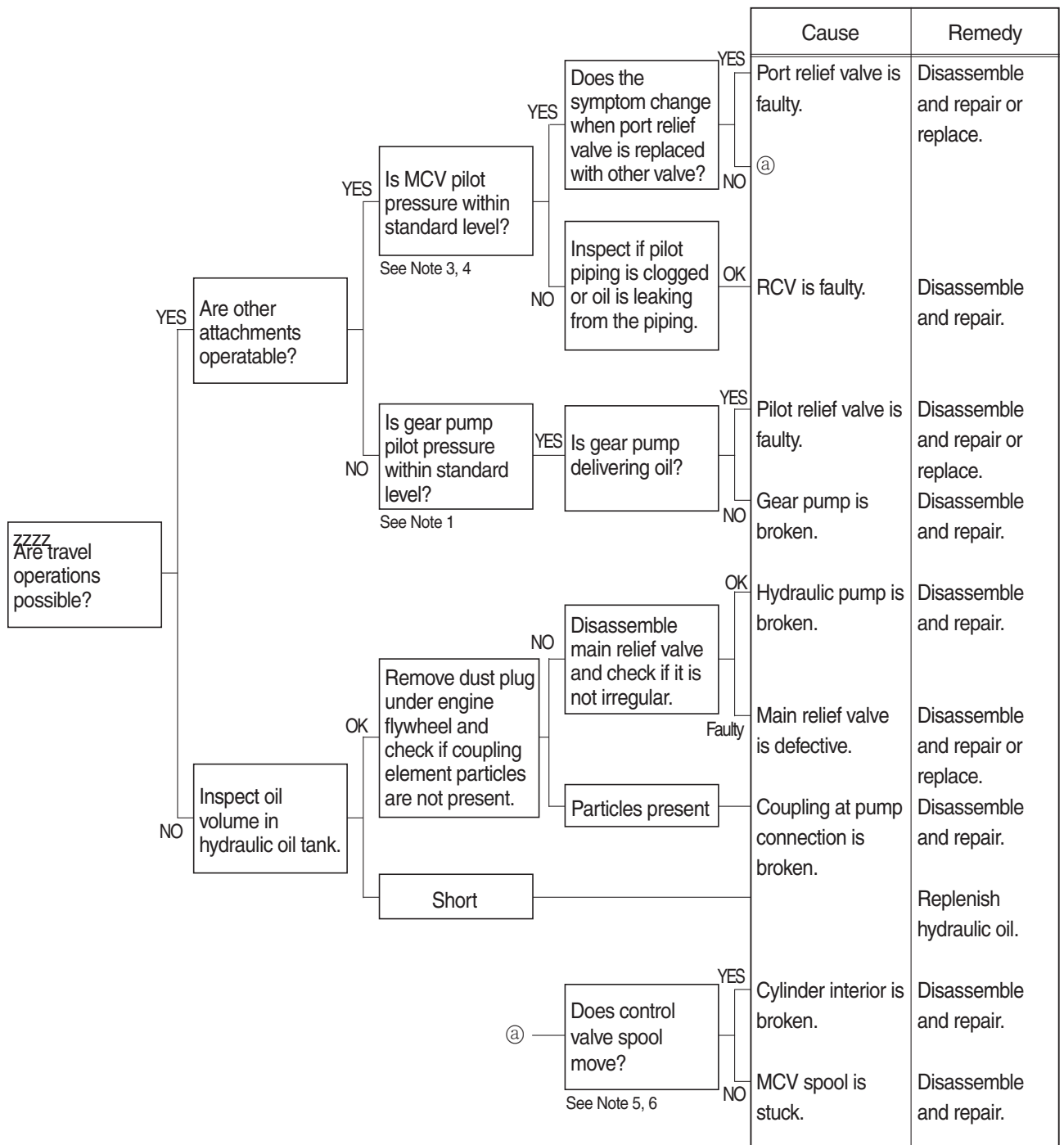

3. BATTERY CHARGING WARNING LAMP LIGHTS UP (Starting switch : ON)

- Before disconnecting the connector, always turn the starting switch OFF.
- Before carrying out below procedure, check all the related connectors are properly inserted.
- After checking, insert the disconnected connectors again immediately unless otherwise specified.

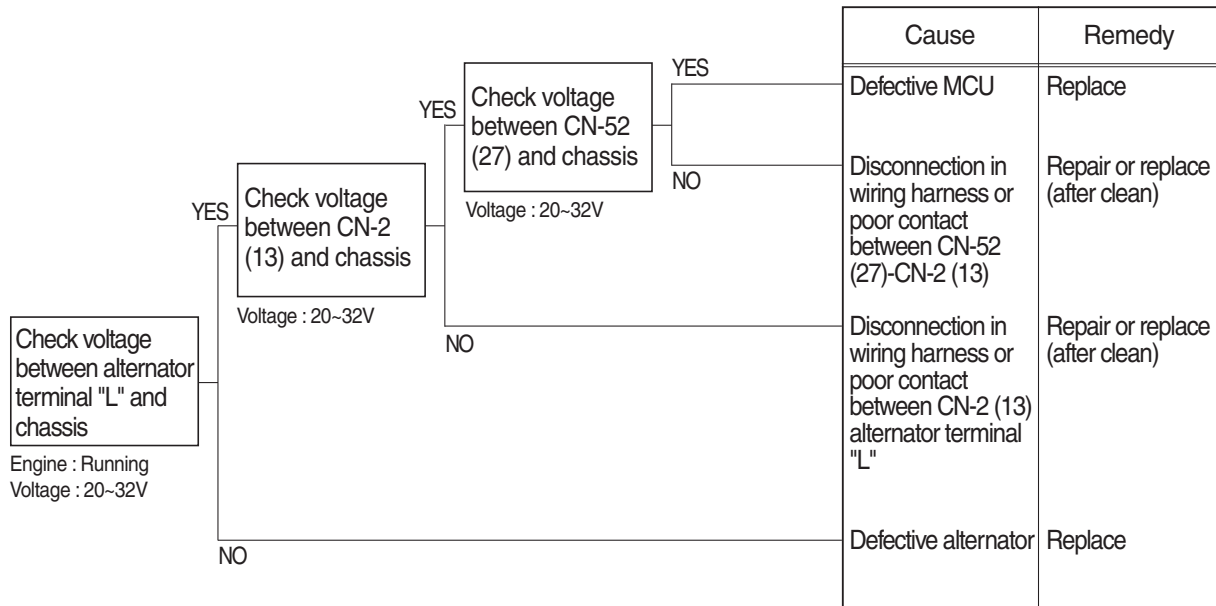

Check voltage

YES	20~32V
NO	0V

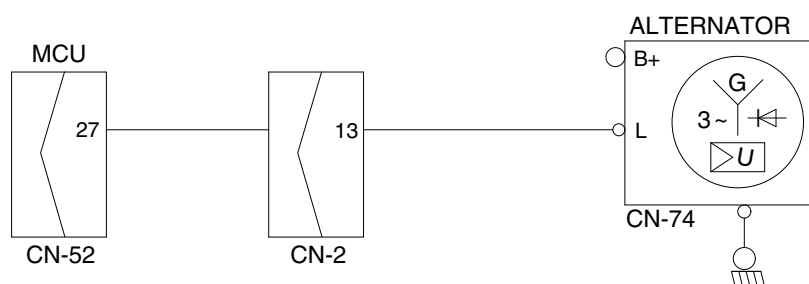

300L6ES03

13. WHEN STARTING SWITCH ON DOES NOT OPERATE

- Before disconnecting the connector, always turn the starting switch OFF.
- Before carrying out below procedure, check all the related connectors are properly inserted, master switch ON and check open circuit of circuit breaker (CN-60, CN-95).
- After checking, insert the disconnected connectors again immediately unless otherwise specified.

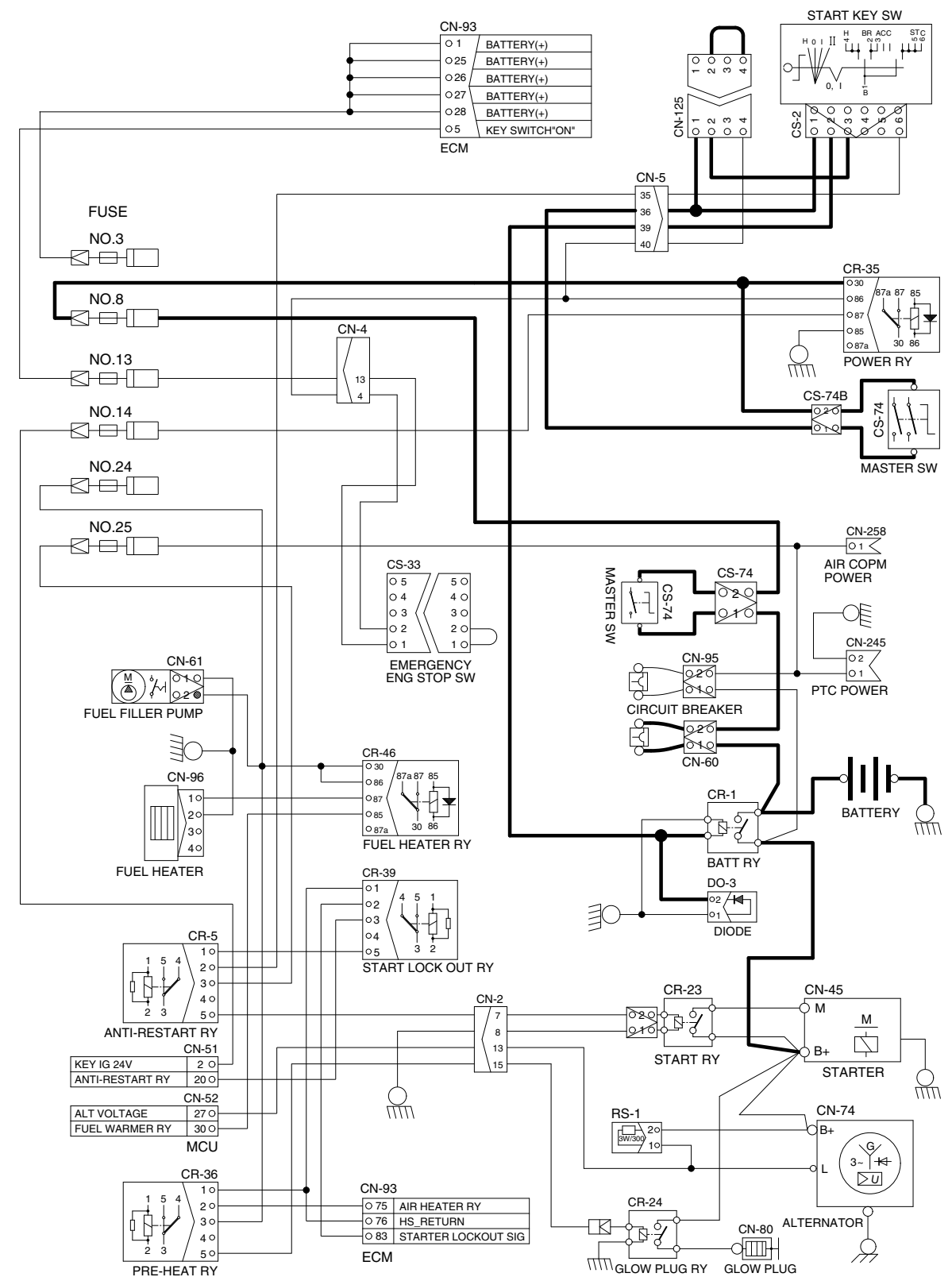
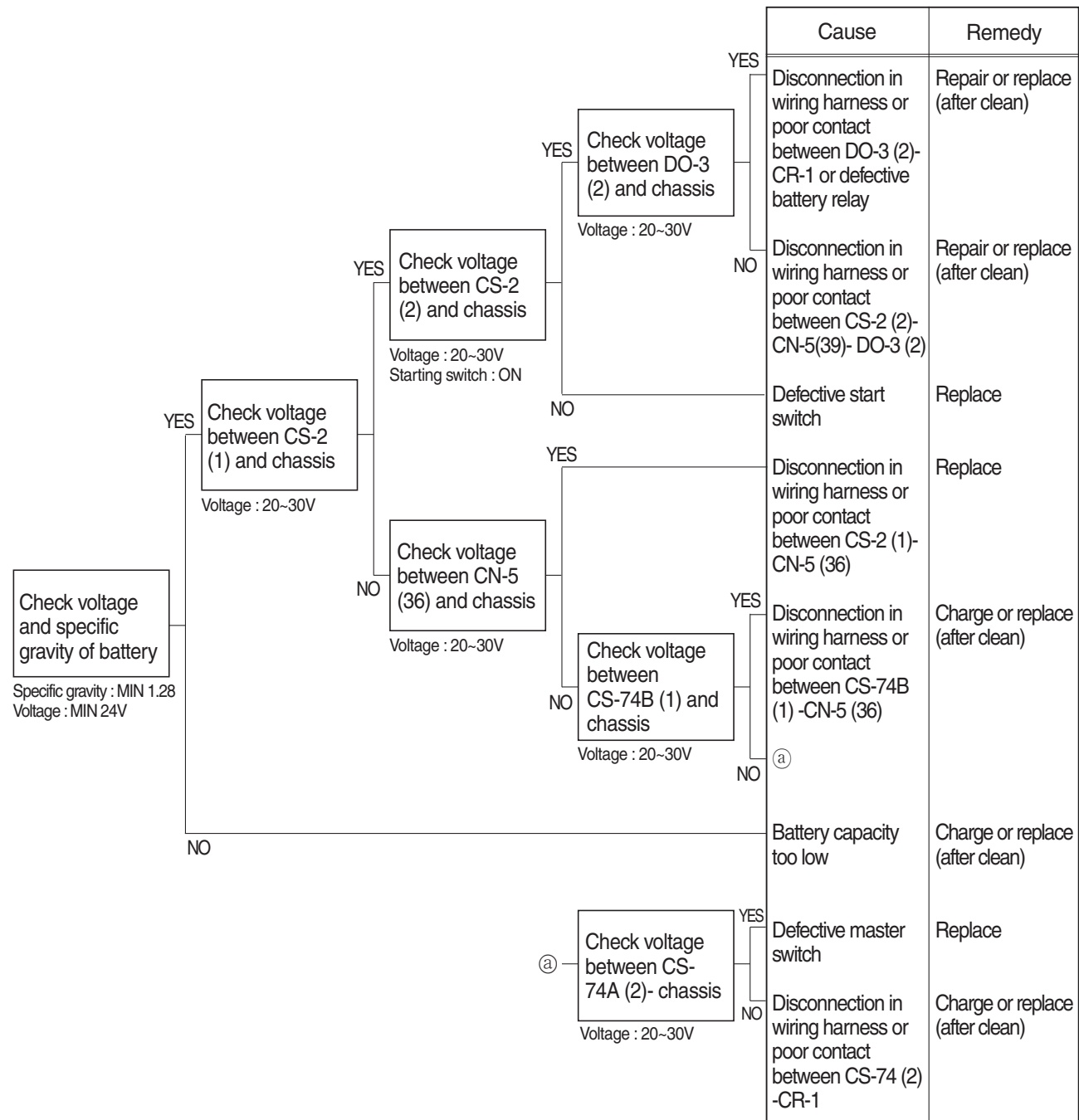

2) TEST PROCEDURE

(1) **Test 7** : Check voltage at CN-52 (38) and ground.

- ① Prepare 1 piece of thin sharp pin, steel or copper.
- ② Insert prepared pin to rear side of connectors : One pin to (38) of CN-52.
- ③ Starting key ON.
- ④ Check voltage as figure.

(2) **Test 8** : Check voltage at CN-52 (37) and ground.

- ① Prepare 1 piece of thin sharp pin, steel or copper
- ② Insert prepared pin to rear side of connectors : One pin to (37) of CN-52.
- ③ Starting key ON.
- ④ Check voltage as figure.

SPEC : Actuator operating : 1~5 V

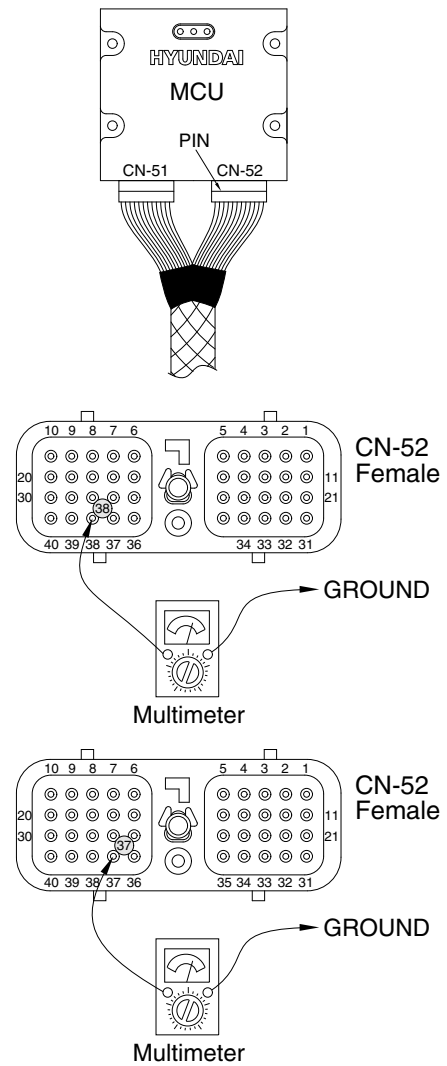

300L6MS04

CLICK HERE TO **DOWNLOAD** THE COMPLETE MANUAL

- Thank you very much for reading the preview of the manual.
- You can download the complete manual from: www.heydownloads.com by clicking the link below



- Please note: If there is no response to CLICKING the link, please download this PDF first and then click on it.

CLICK HERE TO **DOWNLOAD** THE COMPLETE MANUAL

2) TEST PROCEDURE

(1) **Test 13** : Check voltage at CN-52 (17) and ground.

- ① Prepare 1 piece of thin sharp pin, steel or copper.
- ② Insert prepared pin to rear side of connectors : One pin to (17) of CN-52.
- ③ Starting key ON.
- ④ Check voltage as figure.

SPEC : Actuator operating : 1~5 V

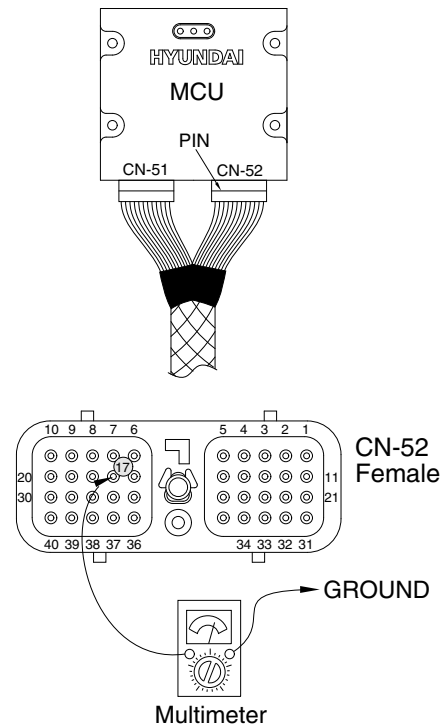

300L6MS14

2) TEST PROCEDURE

(1) **Test 18:** Check voltage between connector CN-88 (2) - GND.

- ① Disconnect connector CN-88 from power max solenoid valve.
- ② Start key ON.
- ③ Check voltage as figure.

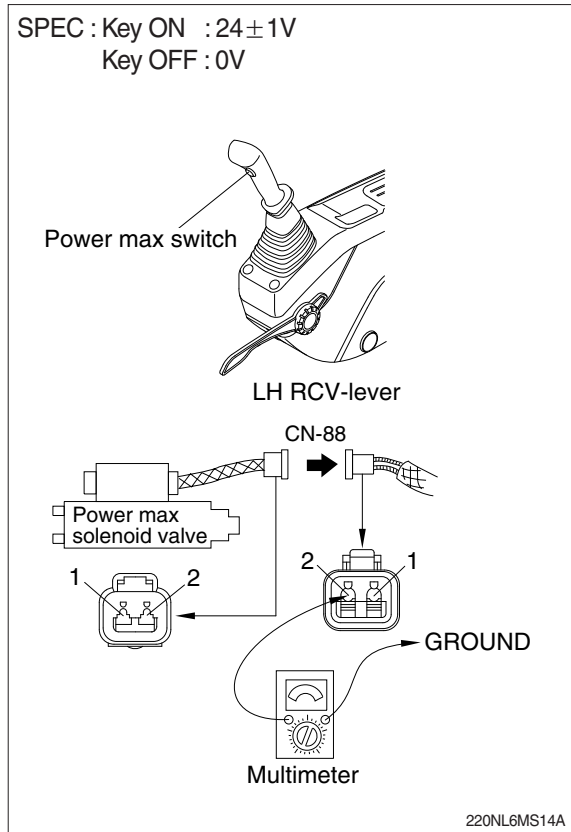

(2) **Test 19:** Check resistance of the solenoid valve between CN-88 (1)-(2).

- ① Starting key OFF.
- ② Disconnect connector CN-88 from power max solenoid valve.
- ③ Check resistance as figure.

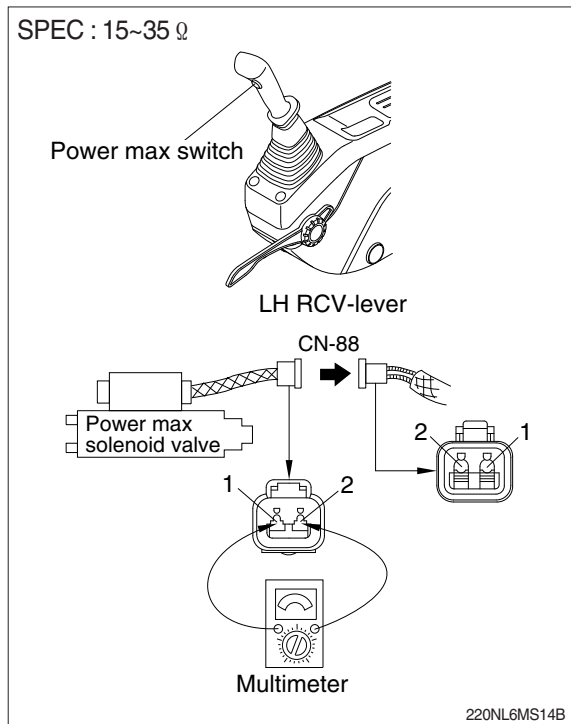

20. MALFUNCTION OF TRAVEL REVERSE PRESSURE SENSOR

· Fault code : HCESPN 531, FMI 0~4

※ Before carrying out below procedure, check all the related connectors are properly inserted.

1) INSPECTION PROCEDURE

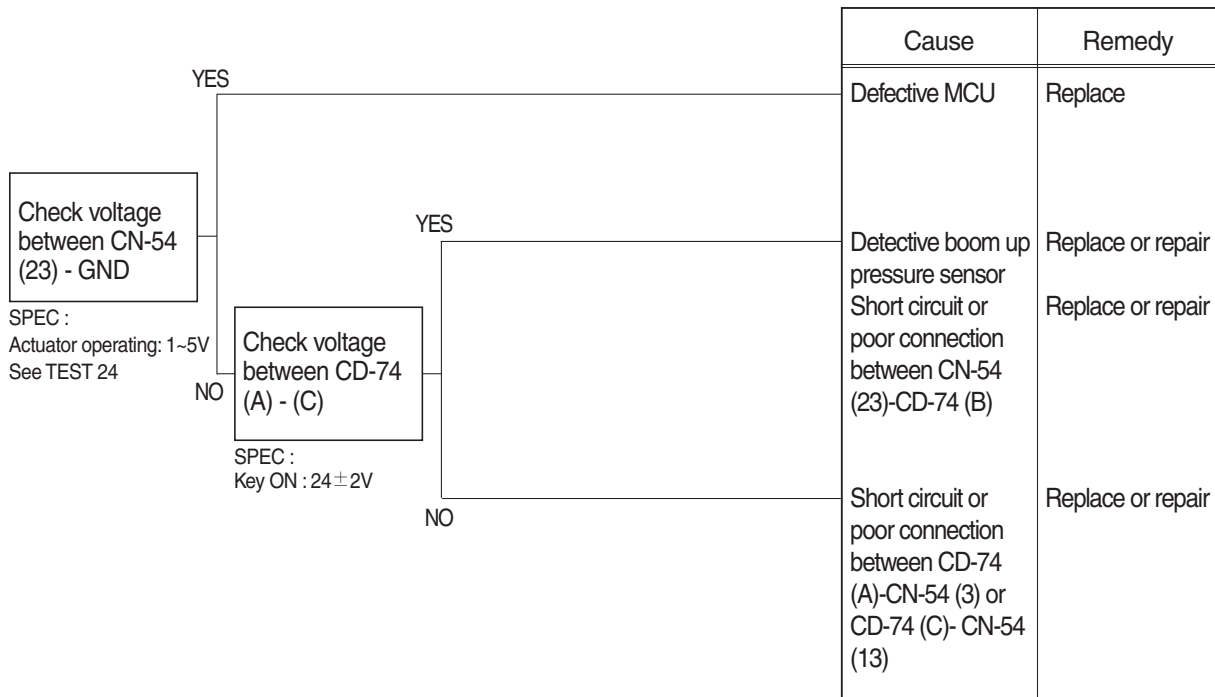

Wiring diagram

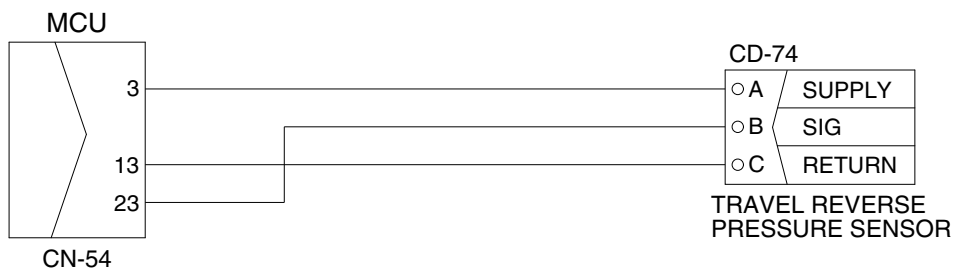

210WF6MS16

4) SWING SPEED

(1) Measure the time required to swing three complete turns.

(2) Preparation

- ① Check the lubrication of the swing gear and swing bearing.
- ② Place the machine on flat, solid ground with ample space for swinging. Do not conduct this test on slopes.
- ③ With the arm rolled out and bucket rolled in, hold the bucket so that the height of the bucket pin is the same as the boom foot pin. The bucket must be empty.
- ④ Keep the hydraulic oil temperature at $50 \pm 5^{\circ}\text{C}$.

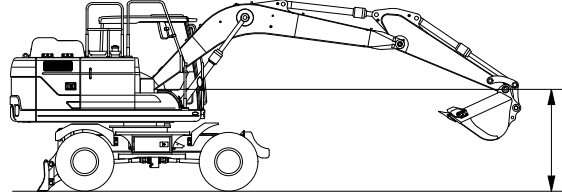

145WF7MS06

(3) Measurement

- ① Select the following switch positions.
 - Power mode switch : P mode
- ② Operate swing control lever fully.
- ③ Swing 1 turn and measure time taken to swing next 3 revolutions.
- ④ Repeat steps ② and ③ three time and calculate the average values.

(4) Evaluation

The time required for 3 swings should meet the following specifications.

Unit : Seconds / 3 revolutions

Model	Power mode switch	Standard	Maximum allowable
HW160 HW180	P mode	19.3 ± 1.5	24.1

13) SWING PARKING BRAKE RELEASING PRESSURE

(1) Preparation

- ① Stop the engine.
- ② Loosen the cap and relieve the pressure in the hydraulic tank by pushing the top of the air breather.
- ③ The pressure release L wrench to bleed air.
- ④ Install a connector and pressure gauge assembly to swing motor SH port, as shown.
- ⑤ Start the engine and check for oil leakage from the adapter.
- ⑥ Keep the hydraulic oil temperature at $50 \pm 5^{\circ}\text{C}$.

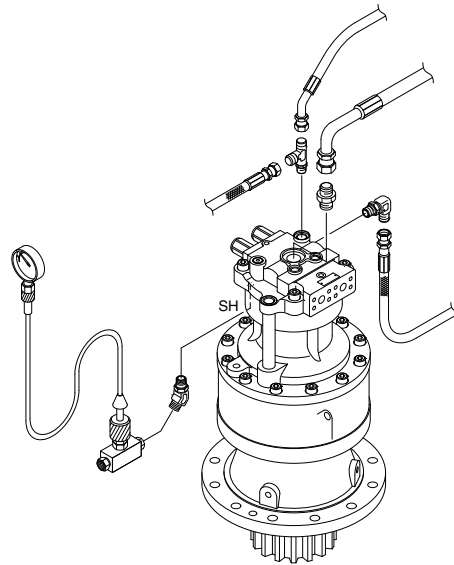

160WF7MS14

(2) Measurement

- ① Select the following switch positions.
 - Power mode switch : P mode
- ② Operate the swing function or arm roll in function and measure the swing brake control pressure with the brake disengaged. Release the control lever to return to neutral and measure the control pressure when the brake is applied.
- ③ Repeat step ② three times and calculate the average values.

(3) Evaluation

The average measured pressure should be within the following specifications.

Unit : kgf / cm²

Model	Description	Standard	Allowable limits	Remarks
HW160 HW180	Brake disengaged	40	Over 9	
	Brake applied	0	-	

7. TURNING JOINT

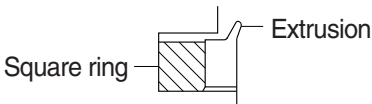
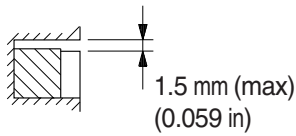
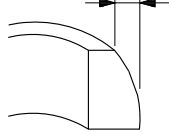
Part name		Maintenance standards	Remedy
Body, Stem	Sliding surface with sealing sections	Plating worn or peeled due to seizure or contamination	Replace
	Sliding surface between body and stem other than sealing section	· Worn abnormality or damaged more than 0.1 mm (0.0039 in) in depth due to seizure contamination	Replace
		· Damaged more than 0.1 mm (0.0039 in) in depth	Smooth with oilstone
	Sliding surface with thrust plate	· Worn more than 0.5 mm (0.02 in) or abnormality	Replace
		· Worn less than 0.5 mm (0.02 in)	Smooth
		· Damage due to seizure or contamination remediable within wear limit (0.5 mm) (0.02 in)	Smooth
Cover	Sliding surface with thrust plate	· Worn more than 0.5 mm (0.02 in) or abnormality	Replace
		· Worn less than 0.5 mm (0.02 in)	Smooth
		· Damage due to seizure or contamination remediable within wear limit (0.5 mm) (0.02 in)	
Seal set	-	<ul style="list-style-type: none"> · Extruded excessively from seal groove square ring 	Replace
	-	<ul style="list-style-type: none"> · Slipper ring 1.5 mm (0.059 in) narrower than seal groove, or narrower than back ring 	Replace
	-	<ul style="list-style-type: none"> · Worn more than 0.5 mm (0.02 in) ~ 1.5 mm (MAX) (0.059 in) 	Replace

2) PIPE AND HOSE (FLARE type)

Thread size (PF)	Width across flat (mm)	kgf · m	lbf · ft
1/4"	19	4	28.9
3/8"	22	5	36.2
1/2"	27	9.5	68.7
3/4"	36	18	130.2
1"	41	21	151.9
1-1/4"	50	35	253.2

3) PIPE AND HOSE (ORFS type)

Thread size (UNF)	Width across flat (mm)	kgf · m	lbf · ft
9/16-18	19	4	28.9
11/16-16	22	5	36.2
13/16-16	27	9.5	68.7
1-3/16-12	36	18	130.2
1-7/16-12	41	21	151.9
1-11/16-12	50	35	253.2

4) FITTING

Thread size	Width across flat (mm)	kgf · m	lbf · ft
1/4"	19	4	28.9
3/8"	22	5	36.2
1/2"	27	9.5	68.7
3/4"	36	18	130.2
1"	41	21	151.9
1-1/4"	50	35	253.2

4) ASSEMBLY

(1) For reassembling reverse the disassembling procedures, paying attention to the following items.

- ① Do not fail to repair the parts damaged during disassembling, and prepare replacement parts in advance.
- ② Clean each part fully with cleaning oil and dry it with compressed air.
- ③ Do not fail to apply clean working oil to sliding sections, bearings, etc. before assembling them.
- ④ In principle, replace seal parts, such as O-rings, oil seals, etc.
- ⑤ For fitting bolts, plug, etc., prepare a torque wrench or so on, and tighten them with torques shown in page 8-11, 12.
- ⑥ For the double-pump, take care not to mix up parts of the front pump with those of the rear pump.

(2) Fit swash plate support (251) to pump casing (271), tapping the former lightly with a hammer.

- ※ After servo piston, tilting pin, stopper (L) and stopper (S) are removed, fit them soon to pump casing in advance for reassembling.
- ※ In tightening servo piston and tilting pin, use a protector to prevent tilting pin head and feedback pin from being damaged. In addition, apply loctite (Medium strength) to their threaded sections.

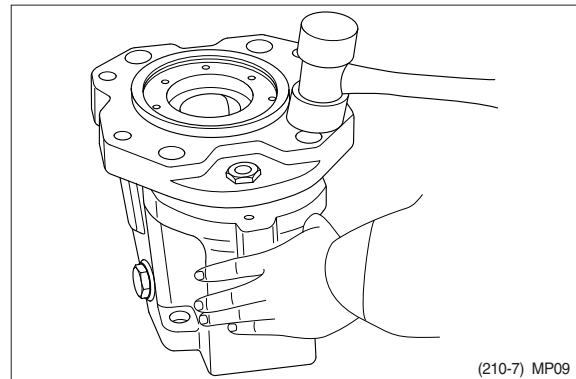

- (11) Remove lever 1 (612). Do not draw out pin (875).
- (12) Draw out pilot piston (643) and spool (652).
- (13) Draw out piston case (622), compensating piston (621) and compensating rod (623).
 - ※ Piston case (622) can be taken out by pushing compensating rod (623) at opposite side of piston case.

This completes disassembly.

3) DISASSEMBLY

(1) Disassembly of spools without holding valve

- ① Loosen hexagon socket head bolts with washer.
(hexagon wrench : 5 mm)
 - ② Remove the pilot cover.
- ※ Pay attention not to lose the O-ring under the pilot cover.
 - ③ Remove the spool assembly from the body by hand slightly.
- ※ When extracting each spool from its body, pay attention not to damage the body.
 - ※ When extracting each spool assembly, it must be extracted from spring side only.
 - ※ When any abnormal parts are found, replace it with completely new spool assembly.
 - ※ When disassembled, tag the components for identification so that they can be reassembled correctly.

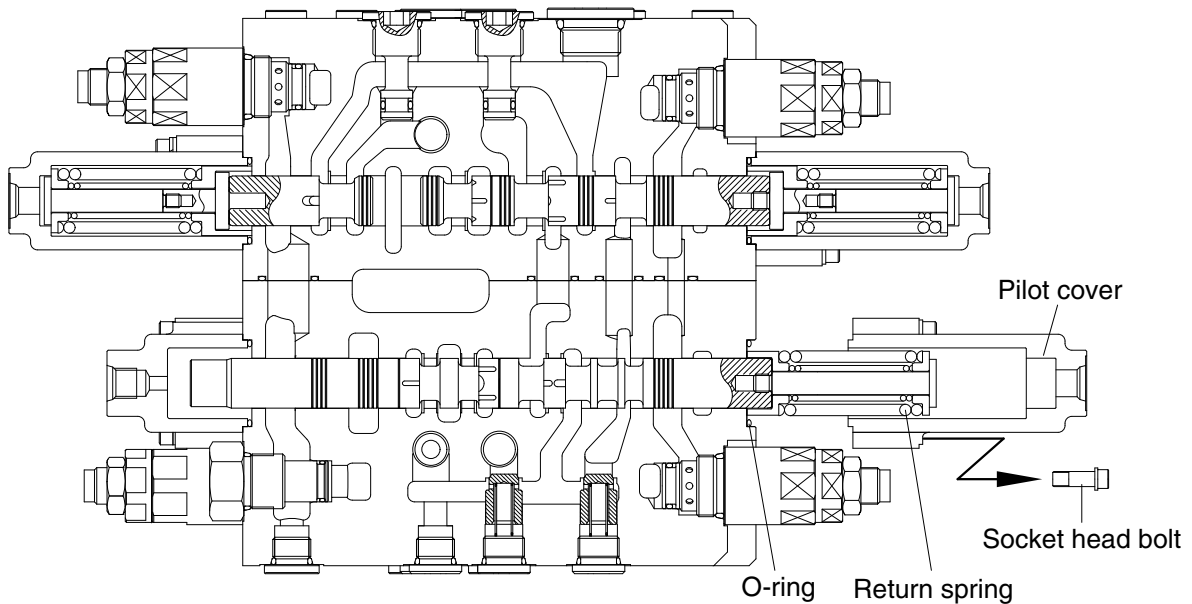

160WF8MC10

2) DISASSEMBLING

(1) Disassemble the sub of a TURNING AXIS

- ① Unloosing wrench bolt and disassemble time delay valve assy (33) from rear cover (21)

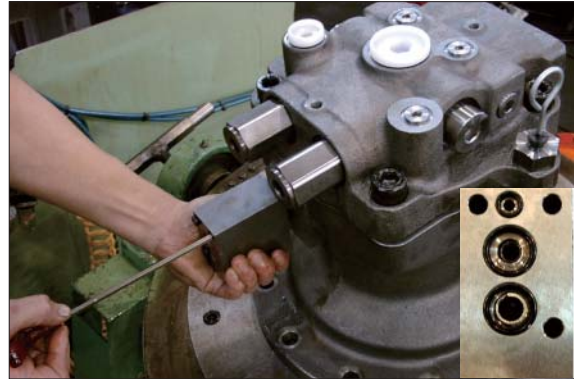

14078SM201/201A

- ② Disassemble level gauge (42) from body (1).



14078SM202/202A

- ③ Hang rear cover (21) on hoist, unloose wrench bolt (25) and disassemble from body (1).



14078SM203/203A

- ③ Assemble respectively plug (43), back up ring, O-ring, O-ring, spring, anti-inversion valve assy (32) into rear cover (21).
(Bilateral symmetry assembling)

- Anti-Inversion v/v assy × 2 set
- O-ring (P12) × 2 EA
- O-ring (P18) × 2 EA
- Back up ring (P18) × 2 EA

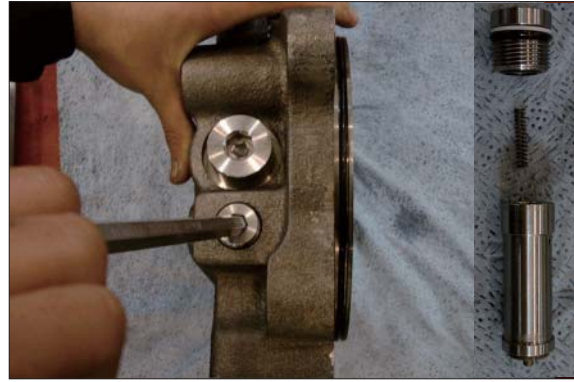

14078SM214/214A

- ④ Assemble relief valve assy (31) 2set into rear cover (21) with a torque wrench.
(Bilateral symmetry assembling)

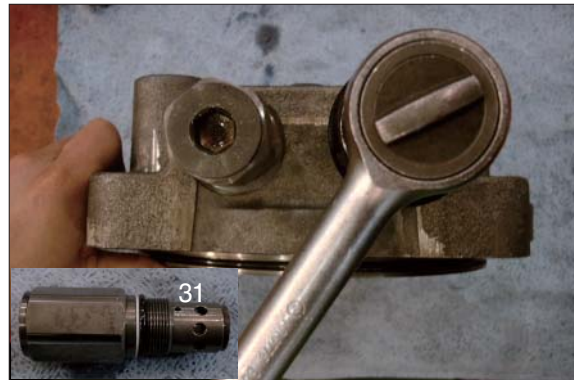

16098SM213/213A

- ⑤ Assemble plug (35), plug (38, 39) into rear cover (21) with a L-wrench.
* Plug × 3 EA (PF1/4)



16098SM216/216A

- ⑥ After assembling needle bearing (22) into rear cover (21), with a hammer assemble pin (8, 23).
* Pin × 1 EA
* Pin × 2 EA



14078SM212

- (5) Assemble carrier 2 (7) assembly correctly to the drive shaft (2).

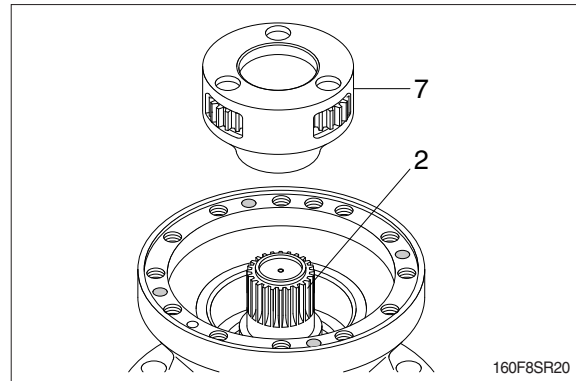

- (6) Assemble sun gear 2 (12) to the center of the carrier 2 (7) assembly.

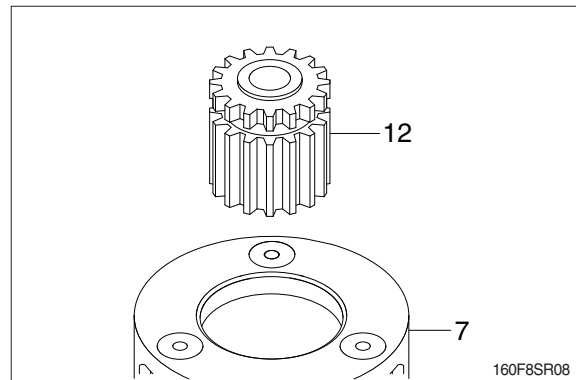

- (7) Assembling carrier 1 (13) assembly.

- ① Assemble the pin 1 (15) to the carrier 1 (13) and then press the spring pin (20) by hammering.
 - ② Punch 2 points of the spring pin's (20) lip.
 - ③ Install side plate 3 (19) onto the center of carrier 1 (15).
 - ④ Install needle cage (16) into the planet gear 1 (18).
 - ⑤ Assemble side plate (17), planet gear 1 (14), side plate 2 (18) and then stop ring (21) to the pin 1 (15).
- ※ Take care not to mistake the matching marks of each part.

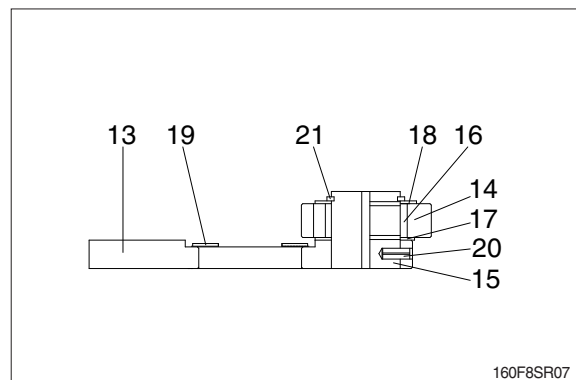

③ Assemble 9 piston assy (12) into retainer plate (11).

- Piston assy × 9EA
- Retainer plate × 1EA



2209A8SM70

④ Assemble parts of procedure ② and ③.

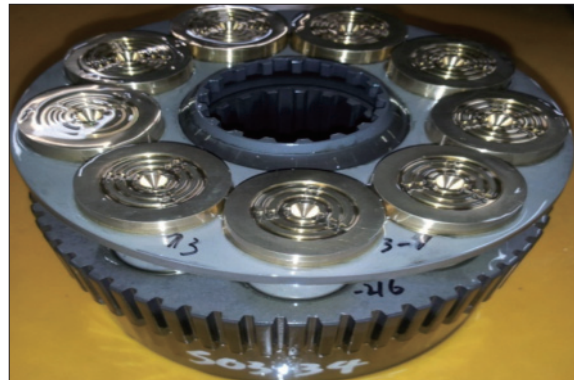

2209A8SM71

(3) Assemble valve casing sub

① Assemble make up check valve sub

Assemble check valve (24), O-ring (27), plug (26) in that order and then screw it torque wrench.

- Make up check valve × 2EA
- Spring × 2EA
- Plug × 2EA
- O-ring × 2EA



2209A8SM72

② Assemble reactionless valve assy

Assemble reactionless valve assy (31), plug (32), O-ring (33, 34) in that order and then screw it a torque wrench.

- Reactionless valve assy (31) × 2EA
- Plug (32) × 2EA
- O-ring (33, 34) × 2EA

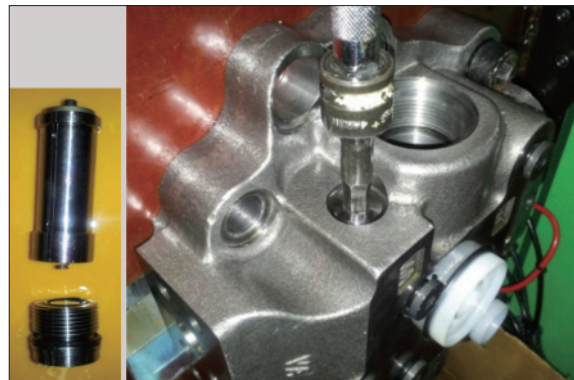

2209A8SM73

- c. Remove drive shaft sub assy from casing.
※ Set a rack for flange of casing, and remove drive shaft sub assy from casing by using press.



2209A8SM09

- d. Remove oil seal & taper bearing (small) from casing.
※ Do not re-use oil seal. It is impossible to disassemble drive shaft sub assy.



2209A8SM10



2209A8SM11

- (4) Screw 12 bolts (M16×45) to connect casing sub assy and ring gear (01) by using torque wrench.

Bolt (M16, 12EA) = 12.9T

The tightening torque = 27 ± 2.7 kgf-m
(195 ± 19.5 lbf-ft)

- ※ Apply enough loctite #242 before screwing bolts.



2209A8SM42

- (5) Use paint marker for checking surplus parts after assembling.

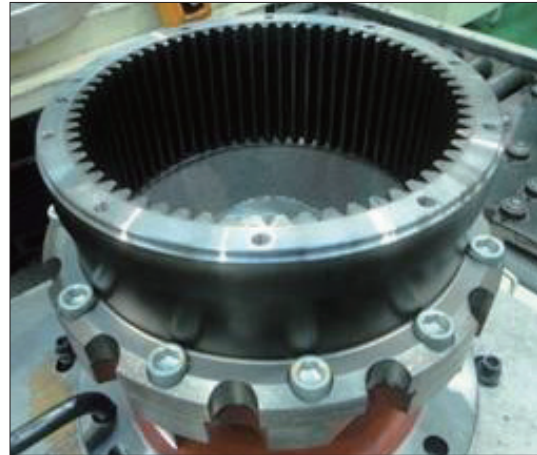

2209A8SM43



2209A8SM44

- (4) Fill up hydraulic aggregates with hydraulic oil before start up.
※ Without fill up bearing damage happens!

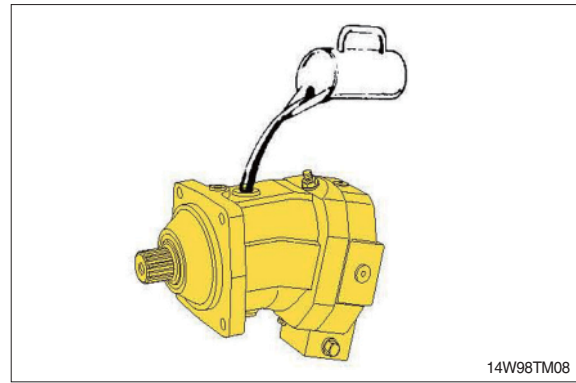

- (5) Seal kit for drive shaft

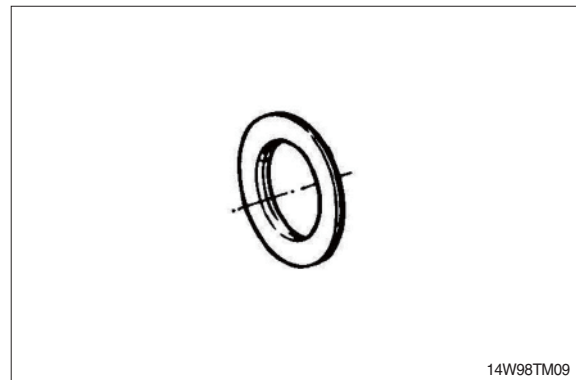

- (6) External seal kit.

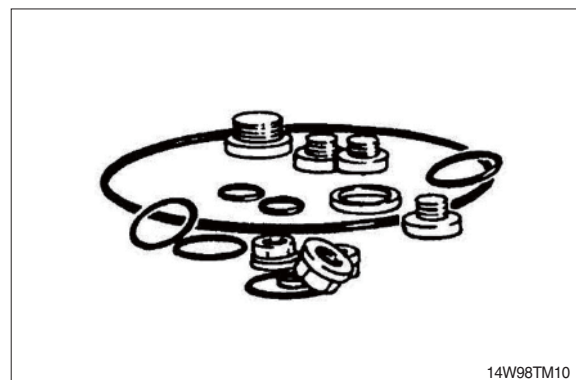

- (7) Housing.

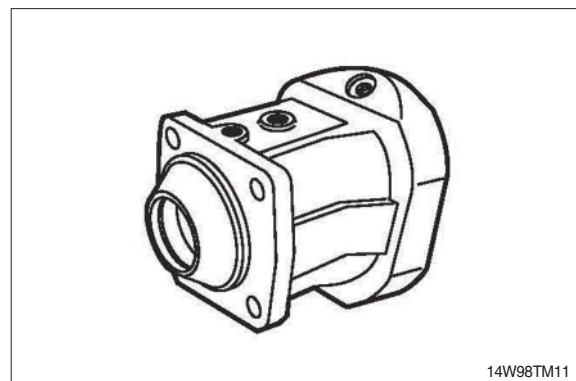

10) EXCHANGING OF THE ROTARY GROUP

- ※ Complete rotary group
Setting of hydraulic part necessary.

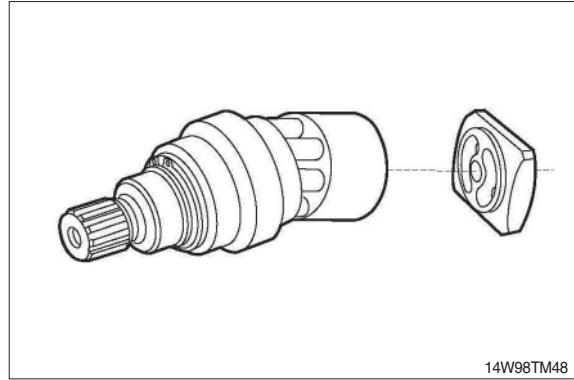

Rotary group

- 1 Mechanical part : Adjust drive shaft with bearing
- 2 Hydraulic part : Adjustment necessary

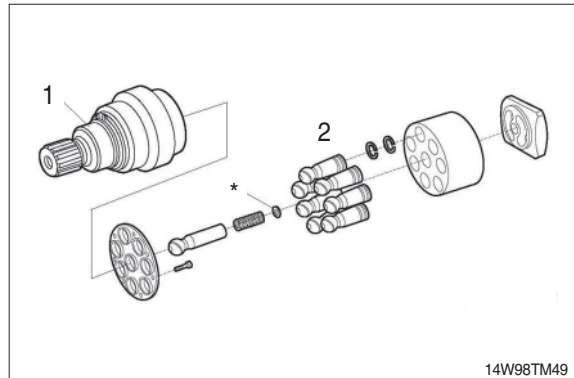

- (1) Remove fixing screw (cylinder).
Remove cylinder.

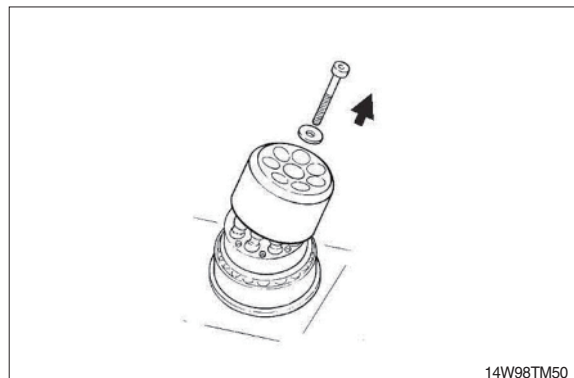

- (2) Disassemble retaining plate.
 - ※ Screws are glued.
 - Use Torx tools.

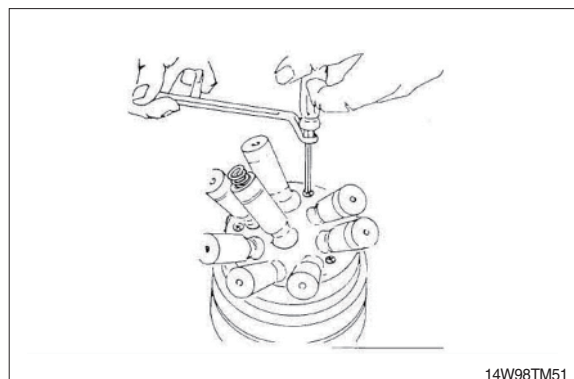

3. SPECIAL TOOLS FOR DISASSEMBLY AND REASSEMBLY

- 1) Assembly truck assy with tilting device

5870 350 000

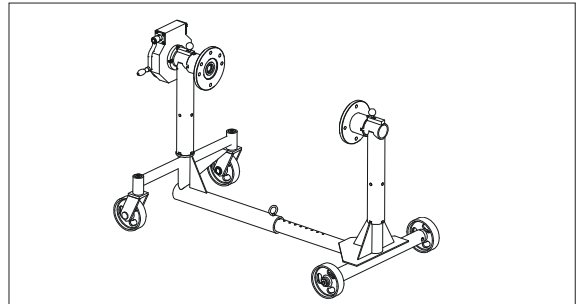

14WF8TM01

- 2) Supporting bracket

5870 350 106

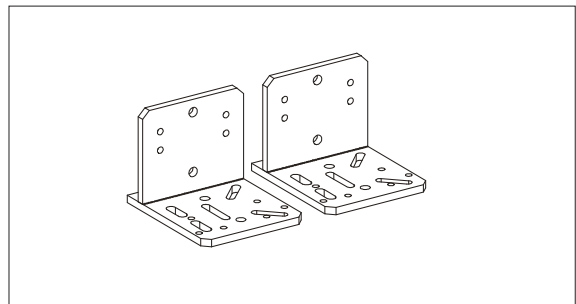

14WF8TM02

- 3) Lifting strap

5870 281 026

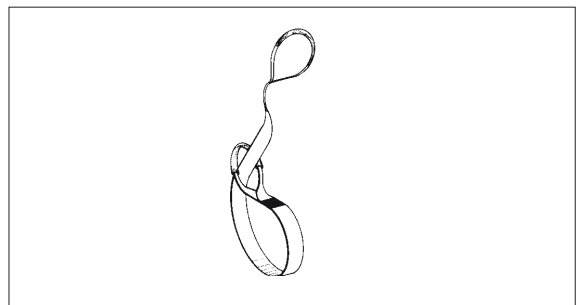

14WF8TM03

- 4) Fixture

5870 350 079

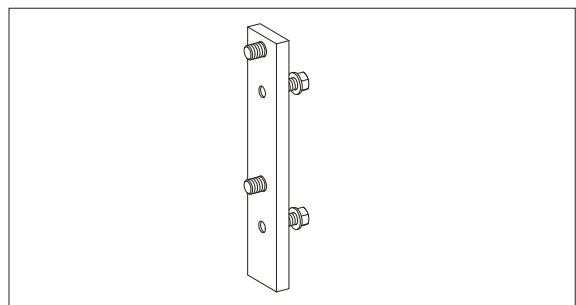

14WF8TM04

- 5) Eye bolt assortment

5870 204 002

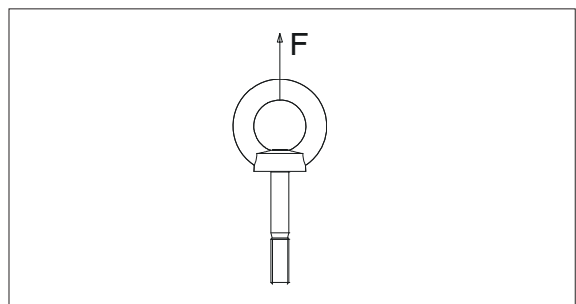

14WF8TM05

6) Torque wrench

5870 203 030	0.6 -6.0 Nm
5870 203 031	1.0 – 12 Nm
5870 203 032	3.0 – 23 Nm
5870 203 033	5.0 – 45 Nm
5870 203 034	10 – 90 Nm
5870 203 039	80 – 400 Nm
5870 203 016	140 – 750 Nm
5870 203 011	750 - 2000 Nm



14WF8TM49



14WF8TM50

7) Hot air blower

5870 221 500	230 V
5870 221 501	115 V

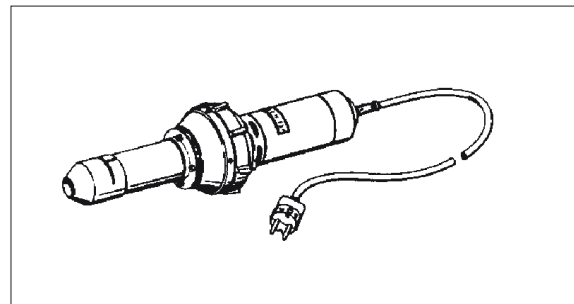

14WF8TM51

8) Plastic hammer

5870 280 004	Ø 60 mm
Substitute nylon insert	
5870 280 006	

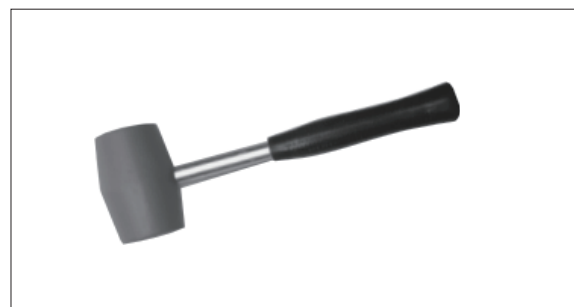

14WF8TM52

9) Lifting strap

5870 281 026

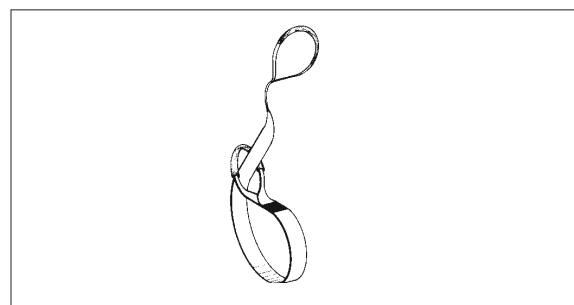

14WF8TM53

20) Remove pressure piece and compression spring.

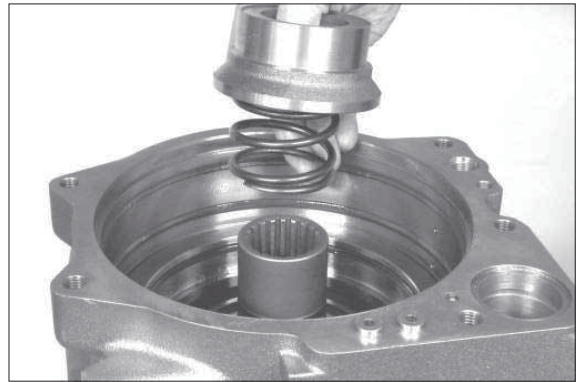

14WF8TM84

21) Remove pressure ring with ring – also see 14WF8TM86 – cautiously with lever – risk of damaging sealing surfaces.

(S) Resetting device 5870 400 001

※ Ring may also remain in housing during disassembly – disassemble ring separately.

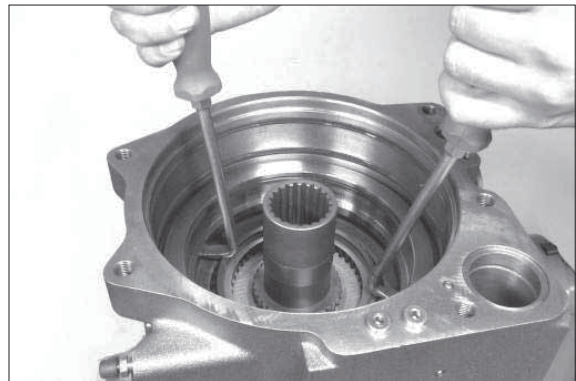

14WF8TM85

22) Remove pressure ring from ring cautiously with lever – risk of damaging sealing surfaces .

(S) Resetting device 5870 400 001



14WF8TM86

23) Remove seal and O-rings (see arrows) from pressure ring and ring.

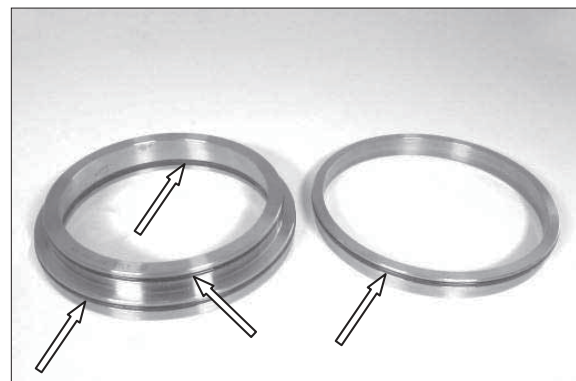

14WF8TM87

12) Remove screen sheet.

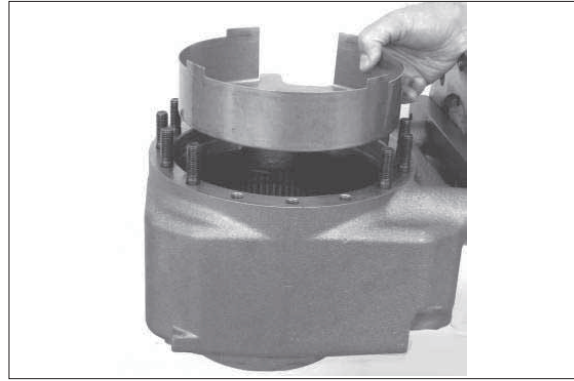

14WF8TM119

13) Disassemble bearing outer ring from housing hole (see arrow).

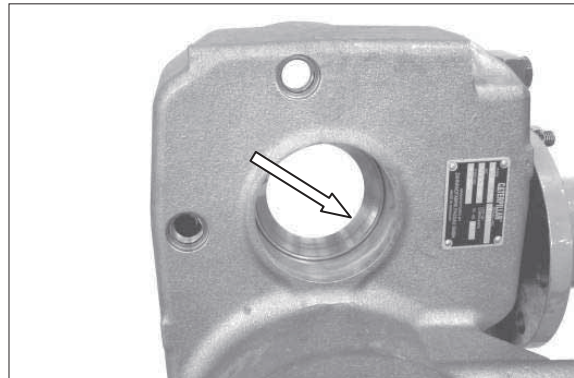

14WF8TM120

14) If necessary, remove stud bolts.



14WF8TM121

Determine adjusting ring for rolling torque/pinion bearing :

23) Rotate transmission by 180°.

Mount adjusting ring (s = optional).

※ It is recommended to reinstall the adjusting ring (e.g. s = 1.35 mm) removed during disassembly, if however the required rolling torque of 1.5~4.0 Nm (without shaft seal) is not obtained – see bearing rolling torque check Fig. 14WF8TM159 – bearing rolling torque is to be corrected with an adequate adjusting ring.

※ When shaft seal is installed, try to achieve upper rolling torque value.

24) Insert heated bearing inner ring until contact.

※ Adjust bearing inner ring after cooling down.

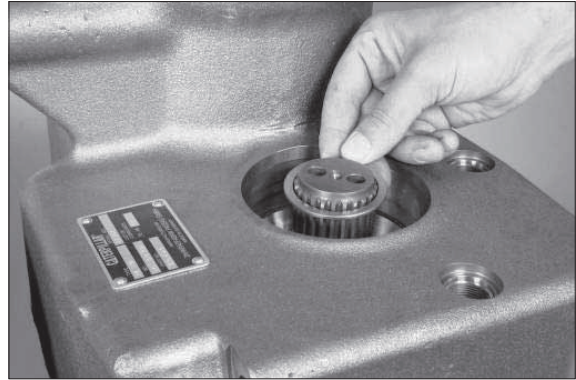

14WF8TM154



14WF8TM155

25) Mount flange.



14WF8TM156

26) Place shim and fix flange with hexagon screws.

Tightening torque (M 10/10.9) $M_A = 68 \text{ Nm}$
(S) Clamping fork 5870 240 025

※ Rotate pinion – when tightening – in both directions (roller setting) several times .

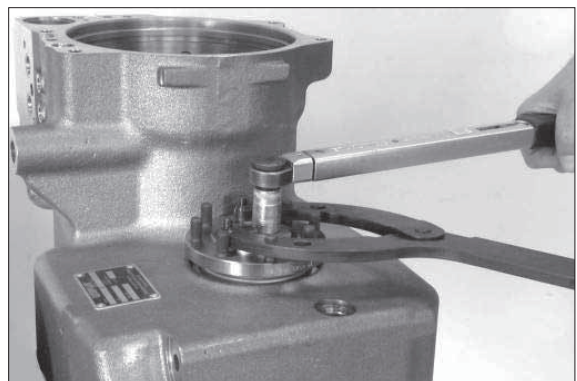

14WF8TM157

- 5) 1 = Planetary carrier
 2 = Slotted pin (6x)
 3 = Center (planetary carrier)

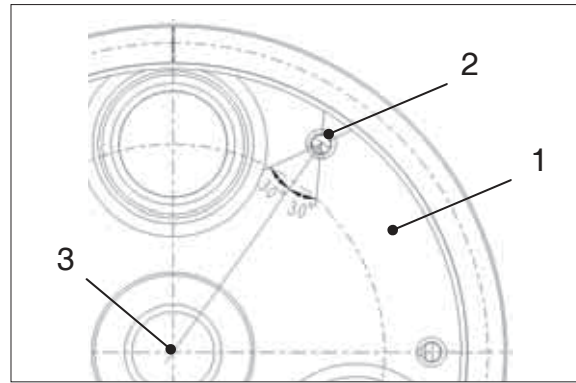

14WF8TM193

- 6) Insert cylindrical roller bearing into planetary gear. Press cylindrical roller bearing through packaging sleeve until snap ring engages into annular groove of planetary gear.

※ Use packaging sleeve to facilitate assembly.

- 1 = Cylindrical roller bearing
 2 = Packaging sleeve
 3 = Snap ring
 4 = Planetary gear

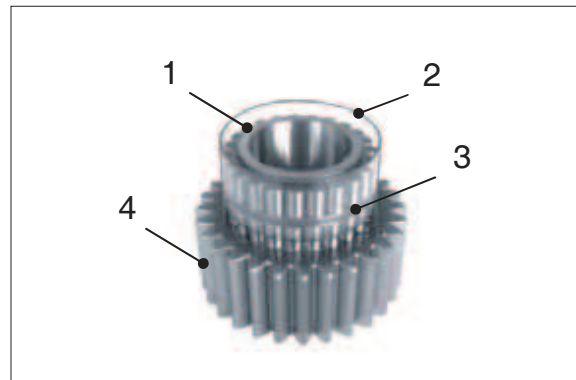

14WF8TM194

- 7) Press on planetary gear over bearing inner ring until contact.

(S) Driver tool 5870 048 283

※ Install planetary gears with large radius on cylindrical roller bearing (downwards) towards planetary carrier.

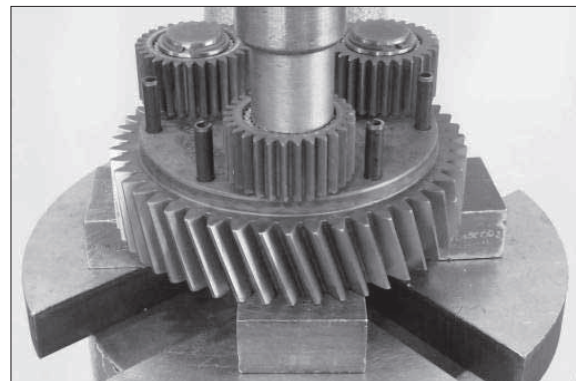

14WF8TM195

- 8) Engage retaining ring.

※ Adjust retaining ring until contact with groove base.



14WF8TM196

- 41) Remove measuring device again – loosen screws evenly.
Remove all cup springs, both pistons, axial roller cage with axial washers and pressure piece.

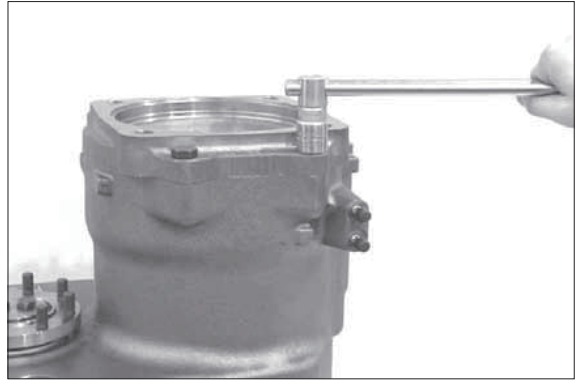

14WF8TM231

- 42) Insert shim into ring gear and fix by engaging snap ring into annular groove of ring gear.

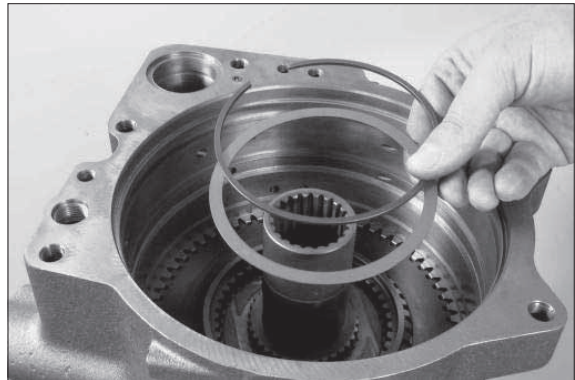

14WF8TM232

- 43) Place O-ring (see arrow) into groove and insert ring.

- ※ Oil sealing surfaces in housing and O-ring for reassembly.
- ※ Observe installation position

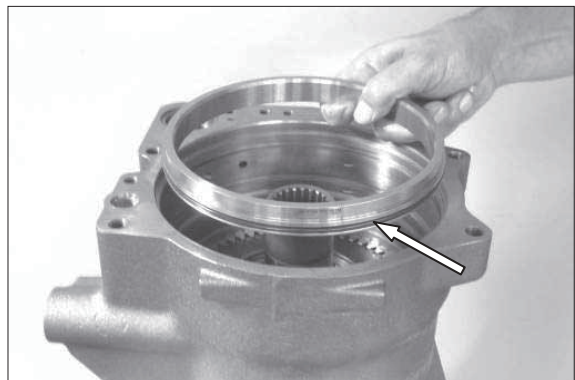

14WF8TM233

- 44) Mount ring with driver tool until contact.

(S) Driver tool 5870 506 161



14WF8TM234

10. DISASSEMBLY - LUBRICATION PUMP/ SHIFT INTERLOCK and VALVE BLOCK

Lubrication pump version

- 1) Loosen threaded joint and pull off cpl. lubrication pump.

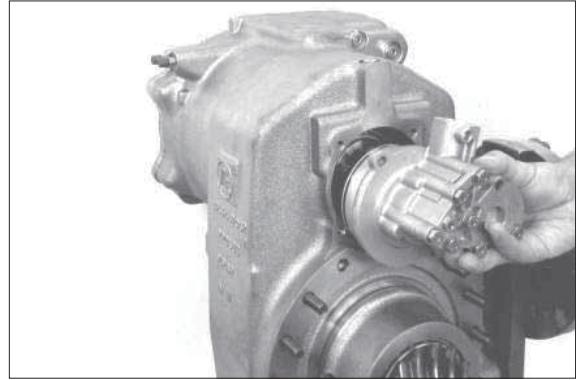

14WF8TM272

- 2) Loosen cover screws, remove cover (1) with seal (2) and filter (3) from housing (4).

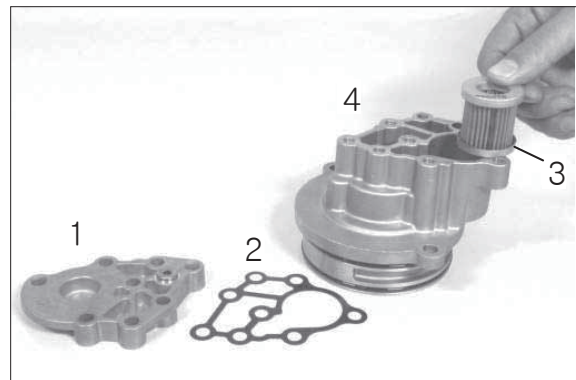

14WF8TM273

- 3) Remove cpl. pressure limiting valve and both O-rings (arrows).

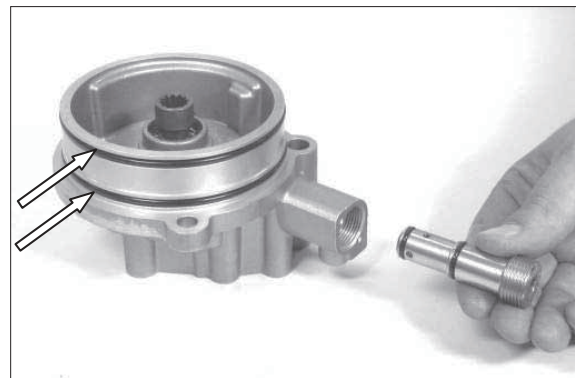

14WF8TM274

- 9) Maintain pump in vertical position while inserting housing with mounted needle sleeve onto preassembled pump.

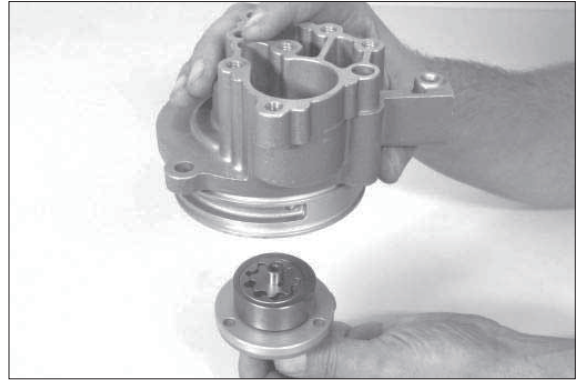

14WF8TM307

- 10) Rotate housing by 180° and fix pump with hexagon screws.
※ Maintain contact position of inserted pump.

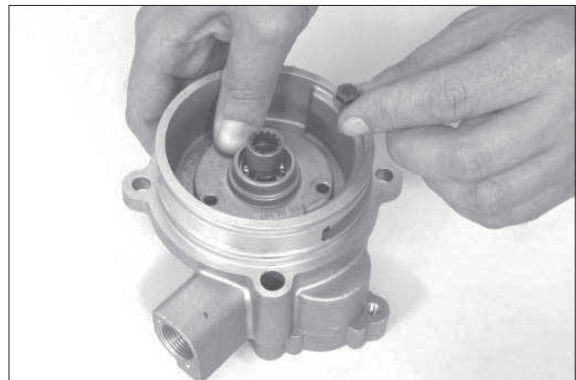

14WF8TM308

- 11) Fix pump.
Tightening torque (M6/8.8) $MA = 9.5 \text{ Nm}$

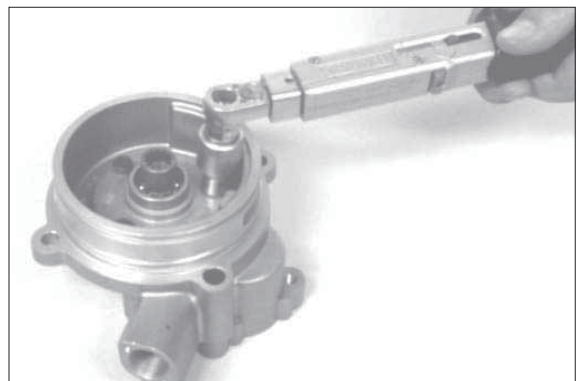

14WF8TM309

- 12) With counter-turning motions on pump shaft, swiveling of control housing (stop LH/RH in pump cover) is audible.

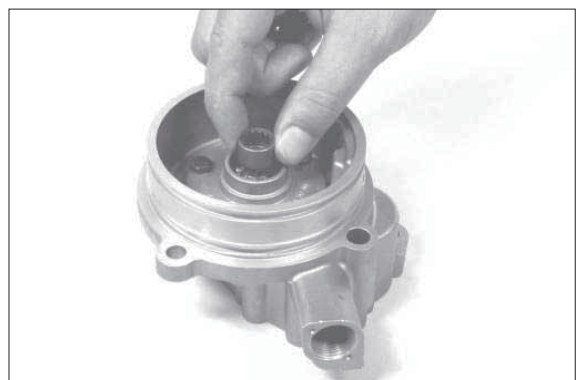

14WF8TM310

25) Oil both O-rings (arrows) and put them into annular groove of housing.

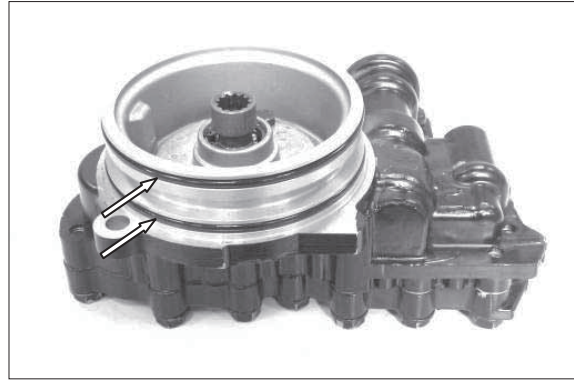

14WF8TM344

26) Insert cpl. shift interlock and fix with cylindrical screws with disks.

Tightening torque (M8/10.9) $M_A = 23 \text{ Nm}$

※ Pay attention to different screw length.

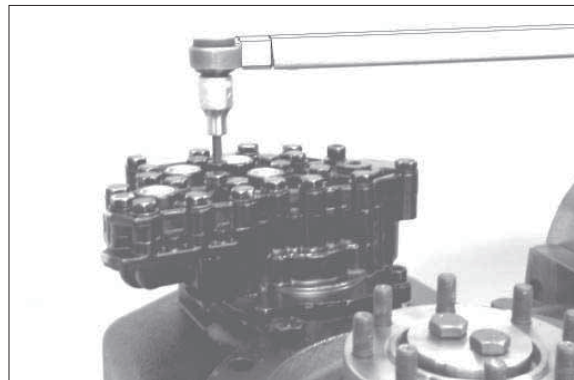

14WF8TM345

27) Install both screw-in sleeves and screw plug (see arrow) with O-rings.

Screw-in sleeve (M 16 × 1.5) $M_A = 30 \text{ Nm}$

Screw plug (M 18 × 1.5) $M_A = 35 \text{ Nm}$

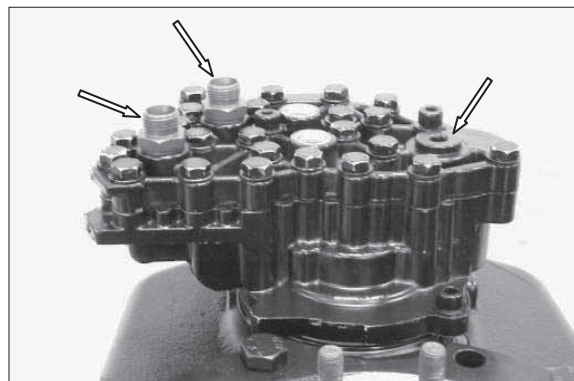

14WF8TM346

28) 1 = Oil tube

2 = Hollow screw (M16 × 1.5)

3 = Seal ring

4 = Hollow screw (M14 × 1.5)

5 = Seal ring



14WF8TM347

(5) Remove distributor plate.

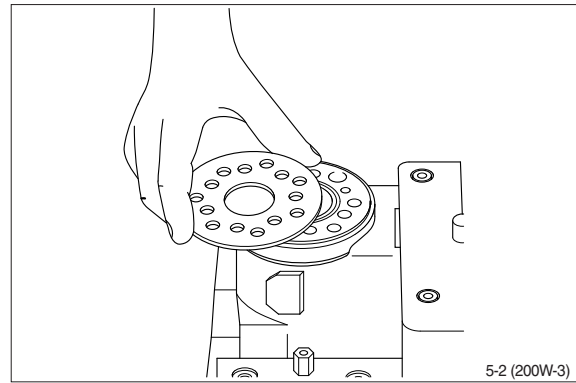

(6) Screw out the threaded bushing over the check valve.

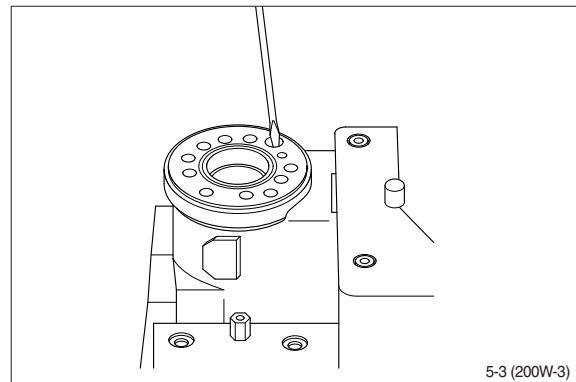

(7) Remove O-ring.

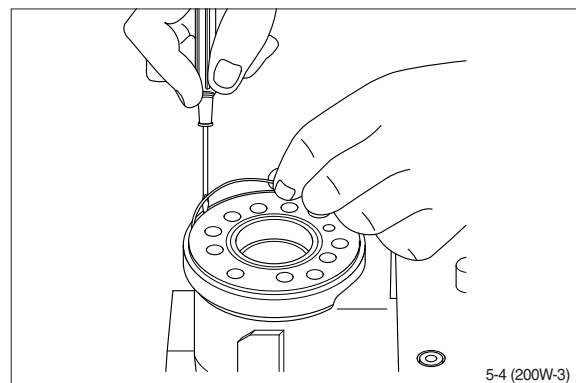

(8) Shake out the check valve ball and suction valve pins and balls.

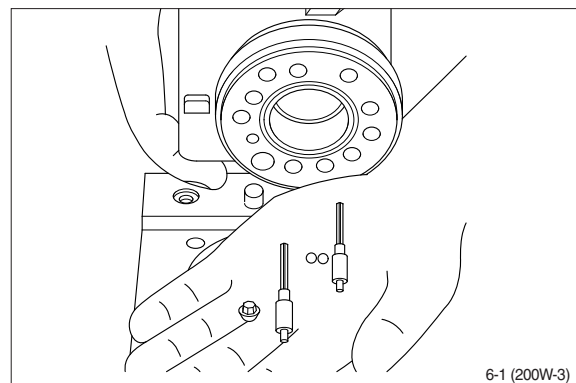

(11) Grease O-ring with hydraulic oil and place them on the tool.

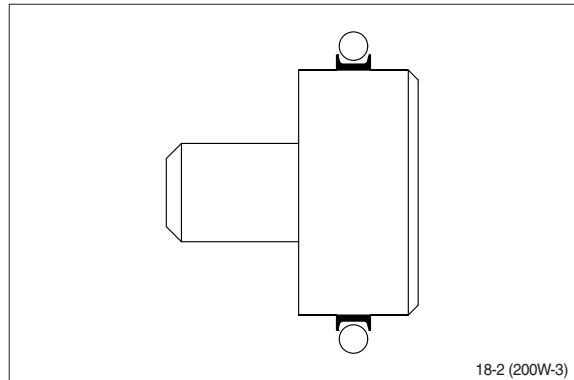
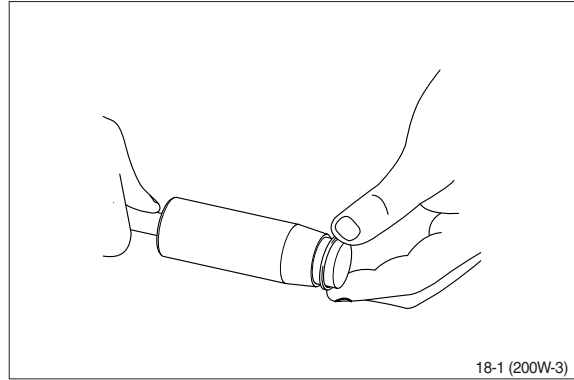

(12) Hole the outer part of the assembly tool in the bottom of the steering unit housing and guide the inner part of the tool right to the bottom.

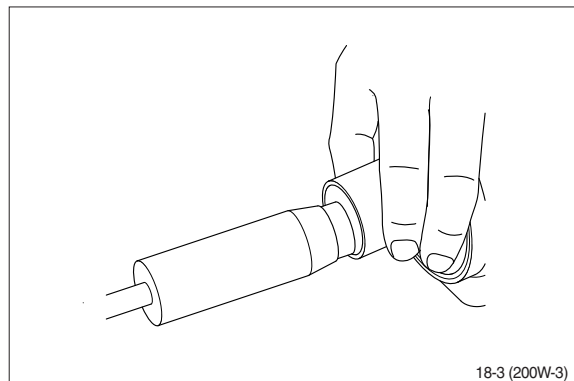

(13) Press and turn the O-ring into position in the housing.

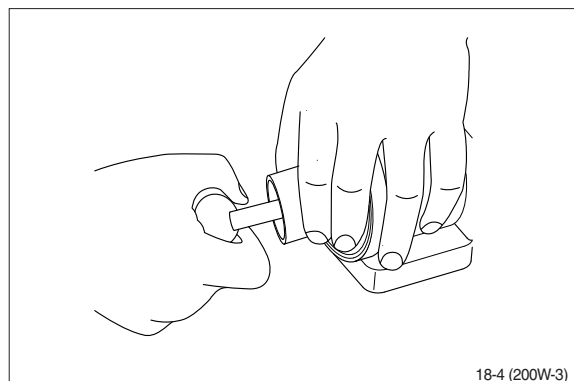

3. GENERAL INSTRUCTIONS

1) GENERAL WORKING INSTRUCTIONS

- (1) This manual has been developed for the skilled serviceman, trained by the ZF-Passau.
- (2) During all operations, pay attention to cleanliness and skilled working.
Therefore, axle removed from the machine, must be cleaned prior to open them.
- (3) We assume that the special tools, specified by ZF, will be used.
The special tools are available from ZF-Passau.
- (4) After the disassembly, all components must be cleansed, especially corners, cavities and recesses of housing and covers.
- (5) The old sealing compound must be carefully removed.
- (6) Check lubricating holes, grooves and pipes for free passage. They must be free of residues, foreign material or protective compounds.
- (7) The latter refers especially to new parts.
- (8) Parts which have been inevitably damaged in a disassembly operation, must be generally replaced by new ones, e.g. rotary seal rings, O-rings, U-section rings, cap boots, protective caps etc..
- (9) Components such as roller bearings, thrust washers, synchronizing parts etc. which are subject to normal wear in automotive operation, must be checked by the skilled Serviceman.
He will decide if the parts can be reused.
- (10) For the heating of bearings etc., hot plates, rod heaters or heating furnaces must be used.
- (11) Never heat parts directly with the flame. An auxiliary solution would be to immerse the bearing in a vessel filled with oil, which is then heated with the flame.
In this way, damage to the bearings could be avoided.
- (12) Ball bearings, covers, flanges and parts like that must be heated to about 90 to 100°C.
- (13) Hot-mounted parts must be reset after cooling in order to assure a proper contact.
- (14) Before pressing shafts, bearings etc. in position, both parts must be lubricated.
- (15) During to reassembly, all specified adjustment values, testing specifications and tightening torque must be respected.
- (16) After the repair, units are filled up with oil.
- (17) After the oil filling, the oil level plugs and oil drain plugs must be tightened to the specified tightening torque.

(17) Remove spacer bushing.



17W98FA029

(18) Pull tapered roller bearing from joint housing.

(S) Grab sleeve 5873 004 026

(S) Pressure piece 5870 100 067



17W98FA030

(19) Knuckle housing

Loosen threaded joint and remove upper bearing pin.

※ Pay attention to releasing O-ring.

※ Remove lower bearing pin only after securing the knuckle housing (see figure FA032).

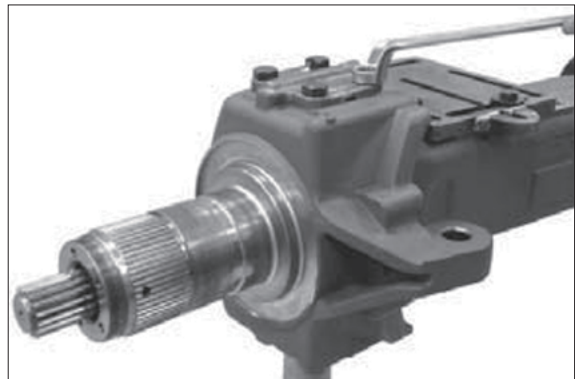

17W98FA031

(20) Secure knuckle housing by means of lifting tackle.

Then loosen threaded joint and remove lower bearing pin.

(S) Eyebolts (M 18) 5870 204 085



17W98FA032

(5) Check axial play of the axle bevel gear $0.0 \sim 0.15$ mm.

※ If the axial play is not within the specified tolerance, correct with the corresponding outer disks.

After the setting procedure separate the single parts again.

Then oil and reassemble all single parts again.

※ Make sure that thickness and arrangement of the second disk package are identical (figure FA071).



17W98FA068

(6) Fix both spider shafts (short) by means of slotted pins (considering installation dimension, see sketch FA070).



17W98FA069

(7) Comment on sketch:

1 = Slotted pin

2 = Spider shaft (short)

3 = Spider shaft

4 = Differential carrier

X = Installation dimension 34 ± 0.5 mm

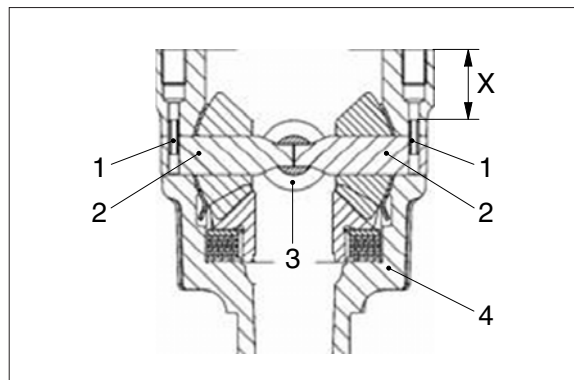

17W98FA070

(8) Mount second axle bevel gear with thrust washer and constant spacer (see also figure FA065).

※ Mount the pressure disk with the coated surface showing to the outer disk.

※ Thickness and arrangement of the disk package must be identical on both sides of the differential gear.



17W98FA071

3) OUTPUT

(1) Preassembly axle housing

Insert bushing into hole of axle housing considering installation dimension "B" and installation position "Y" (see also sketch FA104 and FA106).

(S) Driver tool 5870 055 090

(S) Handle 5870 260 002



17W98FA103

(2) Comment on sketch:

1 = Axle housing

2 = Bushing

B = Installation dimension 1.0 ± 0.3 mm

Y = Installation position / lubrication groove outlet of bushing (top view)

※ Lubrication groove outlet (V-point) must be mounted in 6 o'clock position (bottom) and showing to the oil chamber side.

※ Use of the specified driver tool (S) ensures the exact installation depth of the bushing.

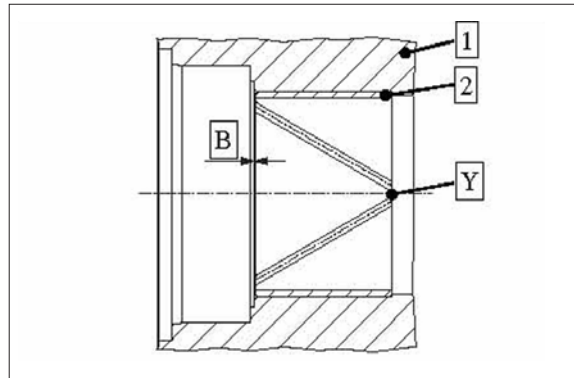

17W98FA104

(3) Flush-mount seal ring with the seal lip showing to the oil chamber (see sketch FA106) into the axle housing hole.

(S) Driver tool 5870 055 090

(S) Handle 5870 260 002

※ Use of the specified driver tool (S) ensures the exact installation position of the shaft seal ring.



17W98FA105

- (7) Fix piston with "new" hexagon screws (1), spring sleeves (2) and compression springs (3 and 4).

Tightening torque (M 6/8.8)
 MA = 8 Nm

※ Use hexagon screws just once.



17W98FA138

- (8) Comment on sketch:

1 = Hexagon screw (special version)

2 = Spring sleeve

3 = Compression spring

4 = Compression spring

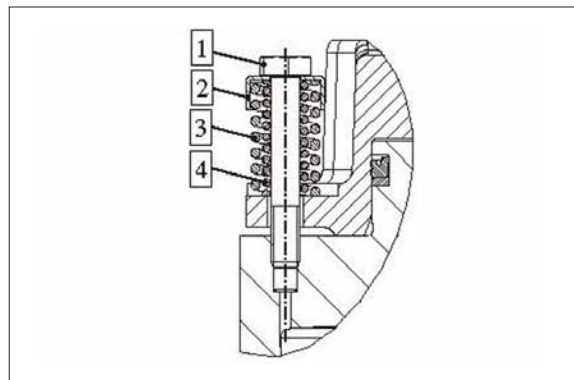

17W98FA139

- (9) Mount preassembled ring gear considering the installation position (markings O in 12 o'clock position - see arrows).

※ Ensure exact tooting position of oil supply holes knuckle housing / ring gear (pressure oil supply to brake piston).

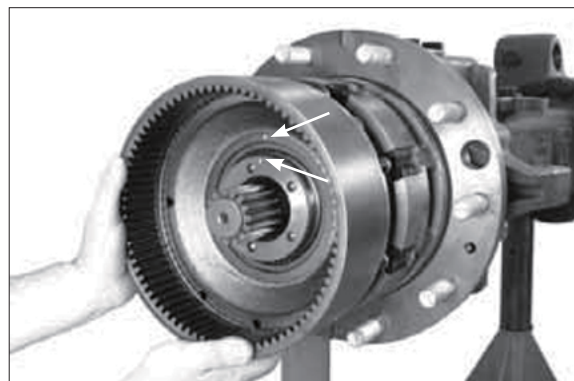

17W98FA140

- (10) Oil O-ring and insert in recess (see arrow).

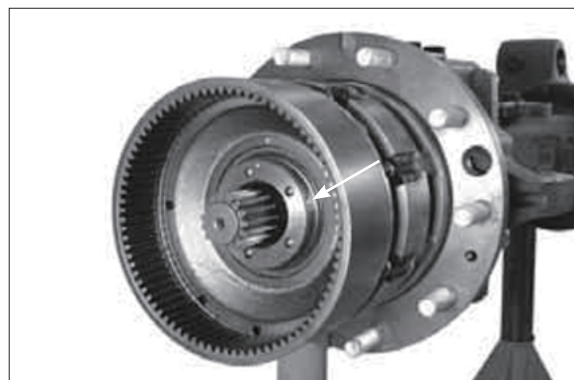

17W98FA141

(15) Insert preassembled steering cylinder into axle housing and fix with hexagon screws.

Tightening torque (M 12/8.8)
..... MA = 79 Nm

- ※ The radial installation position of the steering cylinder (position of the hydr. connections) is customer specific see also disassembly instructions figure FA018.
- ※ Wet the thread of the hexagon screws with Loctite no. 243.

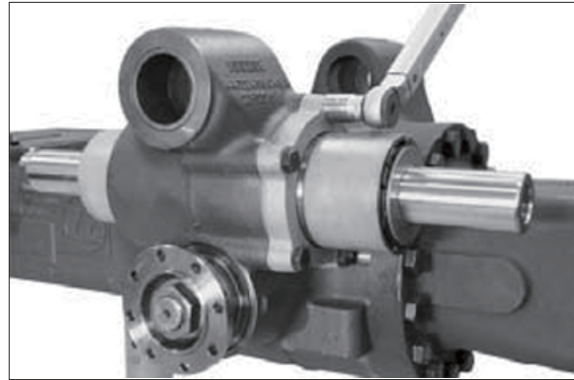

17W98FA174

(16) Bolt hexagon nut (2) and ball joint (3) to axial joint (1).

- ※ Do not tighten hexagon nut before setting the track.

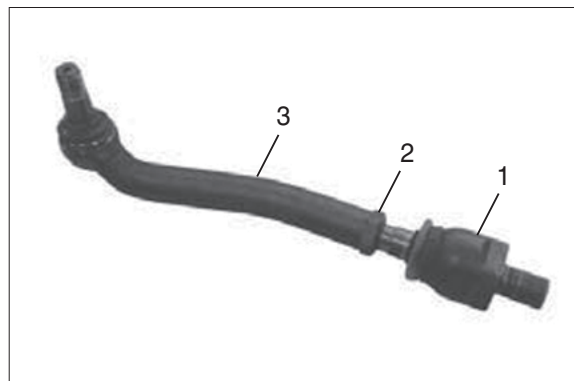

17W98FA175

(17) Fix both tie rods to piston rod (with offset showing to the axle housing).

Tightening torque (M30 × 1.5)
..... MA = 450 Nm

(S) Socket wrench (SW 55) 5870 656 100

- ※ Wet thread of the axial joint with Loctite no. 243.

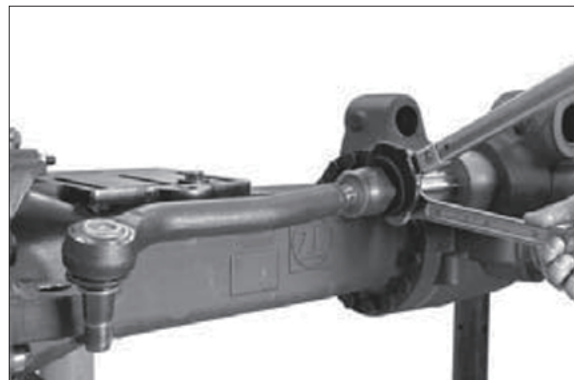

17W98FA176



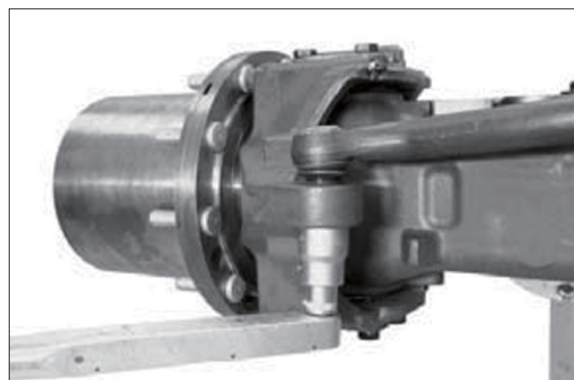

(18) Install tie rod into knuckle housing and fix with "new" locking nut.

Tightening torque (M 27 × 1.5)
..... MA = 600 Nm

- ※ Use locking screws just once.



17W98FA177

No.	Figure	Designation order no.	Qty	Page
31	 <p data-bbox="639 557 746 577">180W9A8FA531</p>	<p data-bbox="770 376 954 405">Handle (FR axle)</p> <p data-bbox="770 432 919 461">5870 260 002</p>	1	8-203, 204, 205
32	 <p data-bbox="639 898 746 918">180W9A8FA532</p>	<p data-bbox="770 696 890 763">Driver tool R140W-9A</p> <p data-bbox="770 790 919 819">5870 058 058</p>	1	-
33	 <p data-bbox="639 1234 746 1254">180W9A8FA533</p>	<p data-bbox="770 1055 890 1084">Driver tool</p> <p data-bbox="770 1111 919 1140">5870 058 022</p>	1	8-204
34	 <p data-bbox="639 1570 746 1590">180W9A8FA534</p>	<p data-bbox="770 1368 986 1435">Driver tool (FR axle) R210W-9A</p> <p data-bbox="770 1462 919 1491">5870 058 078</p>	1	-
35	 <p data-bbox="639 1906 746 1926">180W9A8FA535</p>	<p data-bbox="770 1727 1086 1756">Lever riveting tongs (RR axle)</p> <p data-bbox="770 1783 919 1812">5870 320 016</p>	1	8-275

GROUP 10 REAR AXLE

1. REMOVAL FRONT AXLE

- 1) Rear axle mounting nut (1, M20)
 - Tightening torque : 58 ± 6.3 kgf · m
(419 ± 45.5 lbf · ft)
- 2) Propeller shaft mounting bolt (2, M10)
 - Tightening torque : 5.9 ± 0.6 kgf · m
(42.7 ± 4.3 lbf · ft)
- 3) Wheel nut (3, M22)
 - Tightening torque : 60_{-5}^0 kgf · m
(434_{-36}^0 lbf · ft)
- 4) Hose assy (4)
- 5) Axle weight : 540 kg (1190 lb)

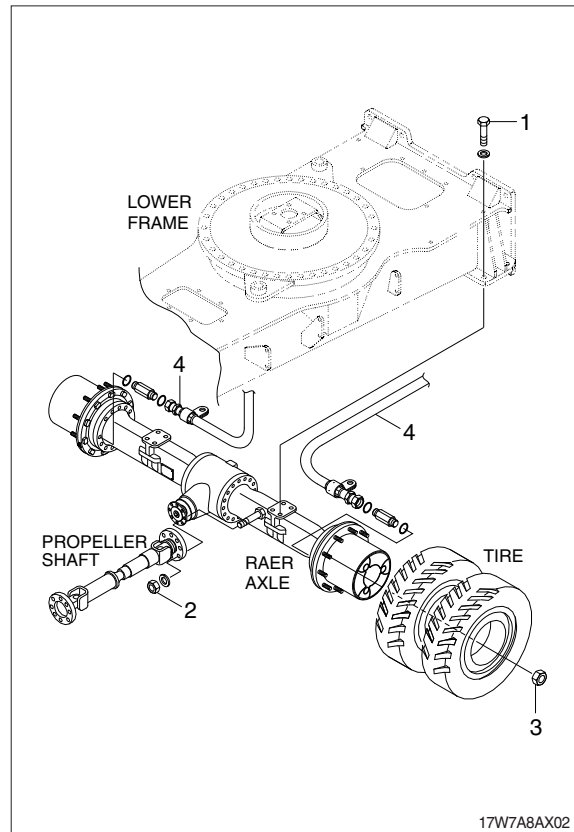

- (3) Secure axle housing (on crown wheel side) by means of lifting tackle and loosen threaded joint.

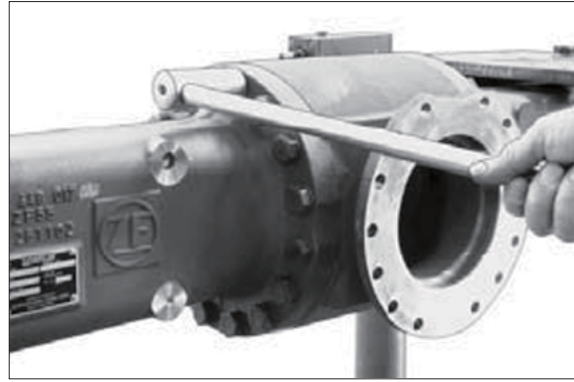

17W98RA025

- (4) Support axle at the axle drive housing (see arrow).

Then separate axle housing from the axle drive housing.

- ※ Pay attention that the differential does not drop.

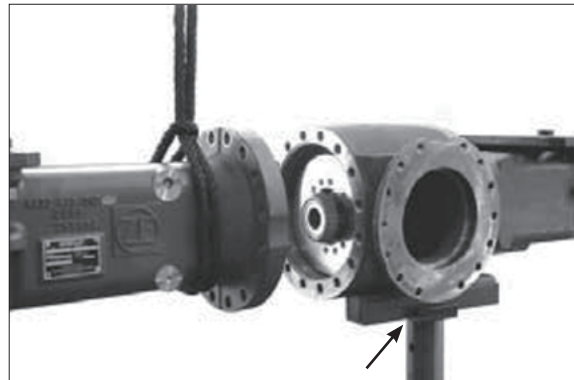

17W98RA026

- (5) Pull bearing outer ring out of the bearing hole and remove the releasing shim.

Then remove O-ring (see arrow).

(S) Striker 5870 650 004

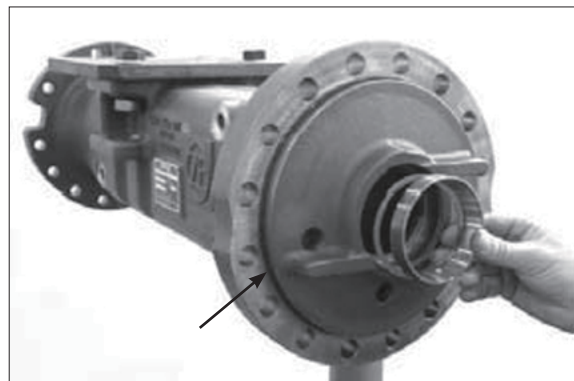

17W98RA027

- (6) Lift differential out of the axle drive housing.

- ※ Disassembly of the differential see description on page 8-257 and following.

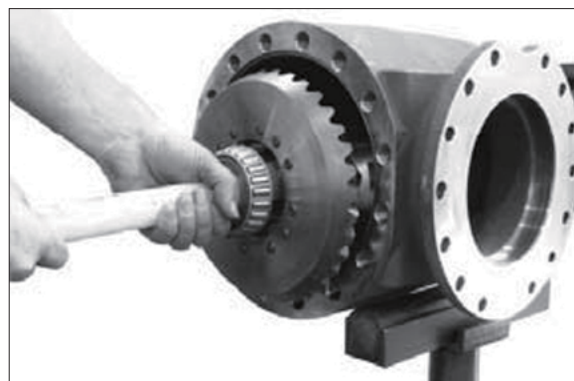

17W98RA028

(12) Fix differential with press and tighten crown wheel with cylindrical screws.

Tightening torque (M12×1.5/12.9)
..... MA = 145 Nm



17W98RA063

(13) Press on both bearing inner rings until contact is obtained.

※ Use an appropriate support (arrow) differential may not be supported on the bearing cage.

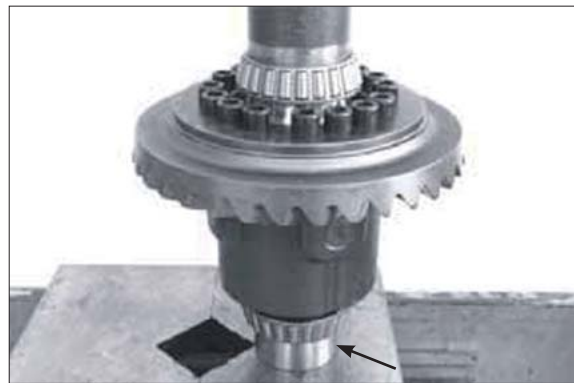

17W98RA064

2) INPUT

(1) Determination of shims for setting the bearing rolling torque (differential bearing) and the backlash (bevel gear set).

※ Determine the required shims on basis of the read value (test dimension/crown wheel) and the corresponding specifications of the table next page :
(KRS – SET – RIGHT) (KRS = bevel gear set)

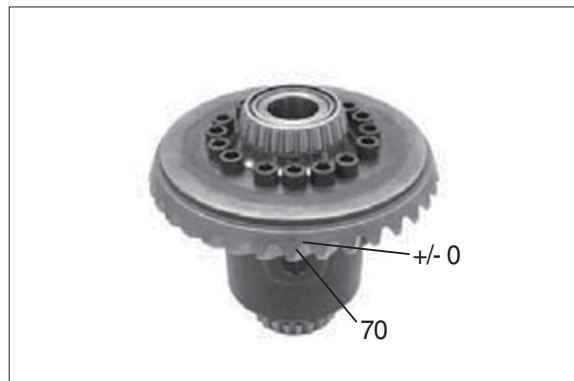

17W98RA065

(19) Use lifting tackle to mount the axle housing (crown wheel side, part II) and preliminarily fix it with hexagon screws.

Tightening torque (M18/10.9)
..... MA = 390 Nm

※ Preliminarily fix axle housing without O-ring.



17W98RA095

(20) By rotating the input flange, roll crown wheel over the input pinion in both directions several times.

Then remove axle housing and lift differential out of the axle drive housing. Compare the obtained contact pattern with contact pattern.

※ In case of a contact pattern deviation it is imperative to correct the measuring error which was made when determining the shim (figure RA080).



17W98RA096

(21) After contact pattern check, place differential into the axle drive housing.

Grease O-ring (see arrow) and mount it to the axle housing.



17W98RA097

(22) Use lifting tackle to mount the axle housing and finally fix it with hexagon screws.

Tightening torque (M18/10.9)
..... MA = 390 Nm

Then bring axle into horizontal position and reassemble the second supporting bracket (S) (see also figure RA001).



17W98RA098

(30) Secure slotted nut with cylindrical screw
(see also figure RA127).

Tightening torque (M 10/8.8)
..... MA = 32 Nm

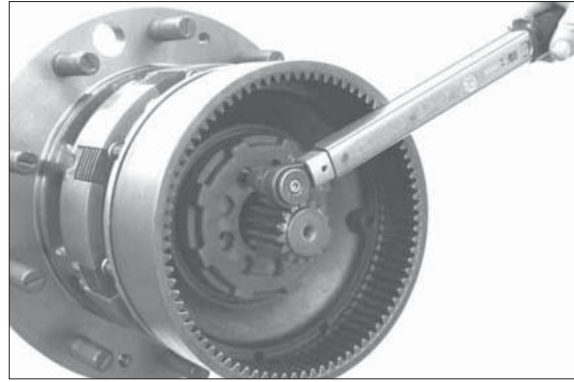

17W98RA132

(31) Planetary carrier

Press thrust washer into the planetary carrier until contact is obtained.

(S) Driver tool 5870 048 263



17W98RA133

(32) Insert the cylindrical roller bearing into the planetary gear – for this purpose press the cylindrical roller bearing through the packaging sleeve until the snap ring engages into the annular groove of the planetary gear.

※ Use packaging sleeve to facilitate assembly.

1 = Cylindrical roller bearing

2 = Packaging sleeve

3 = Snap ring

4 = Planetary gear

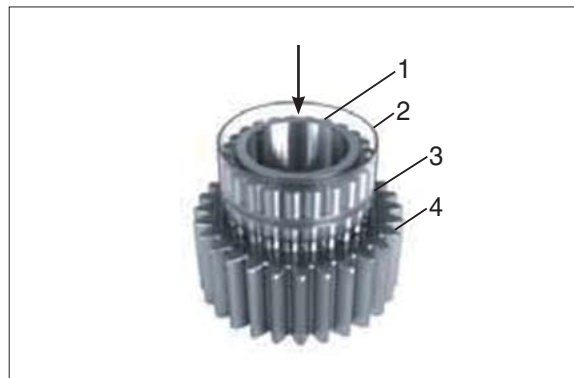

17W98RA134

(33) Heat up bearing inner ring and mount preassembled planetary gear until contact is obtained.

※ Mount bearing inner ring with the large radius facing the planetary carrier (downwards).



17W98RA135

(15) Cleaning of parts

- ① Put all parts in rough cleaning vessel filled with kerosene and clean them (rough cleaning).
 - ※ If dirty part is cleaned with kerosene just after putting it in vessel, it may be damaged. Leave it in kerosene for a while to loosen dust and dirty oil.
 - ※ If this kerosene is polluted, parts will be damaged and functions of reassembled valve will be degraded.
Therefore, control cleanliness of kerosene fully.
- ② Put parts in final cleaning vessel filled with kerosene, turning it slowly to clean them even to their insides (finish cleaning).
 - ※ Do not dry parts with compressed air, since they will be damaged and/or rusted by dust and moisture in air.

(16) Rust prevention of parts

- Apply rust-preventives to all parts.
- ※ If left as they are after being cleaned, they will be rusted and will not display their functions fully after being reassembled.

3) ASSEMBLY

- ※ Clean all parts.
- ※ As a general rule, replace oil seals and O-ring.
- ※ Coat the sliding surfaces of all parts with engine oil or grease before installing.

(1) Fit O-ring (8), seventeen slipper seal (6), and wear ring (11).

(2) Fit O-ring (7) to shaft (2).

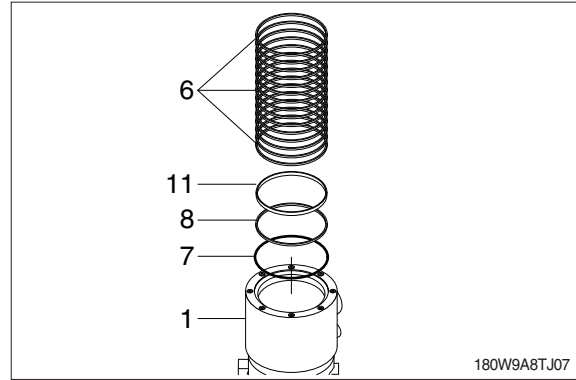

(3) Set shaft (2) on block, tap hub (1) with a plastic hammer to install.

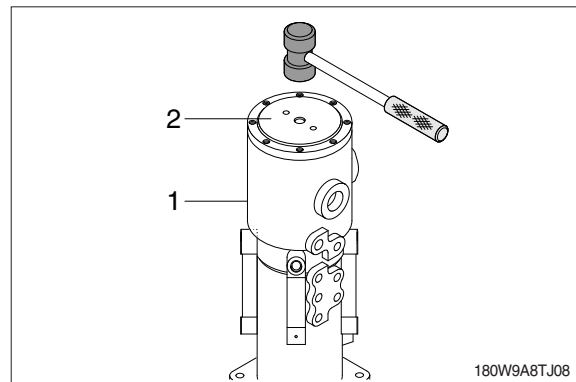

(4) Fit shim (5), and spacer (4) to hub (1) of turning joint upside.

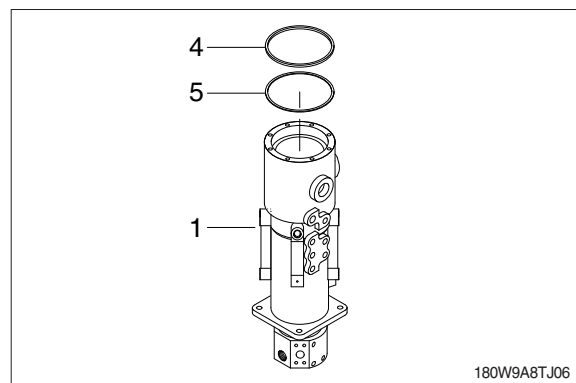

2. DISASSEMBLY AND ASSEMBLY

1) STRUCTURE

(1) Bucket cylinder (HW160)

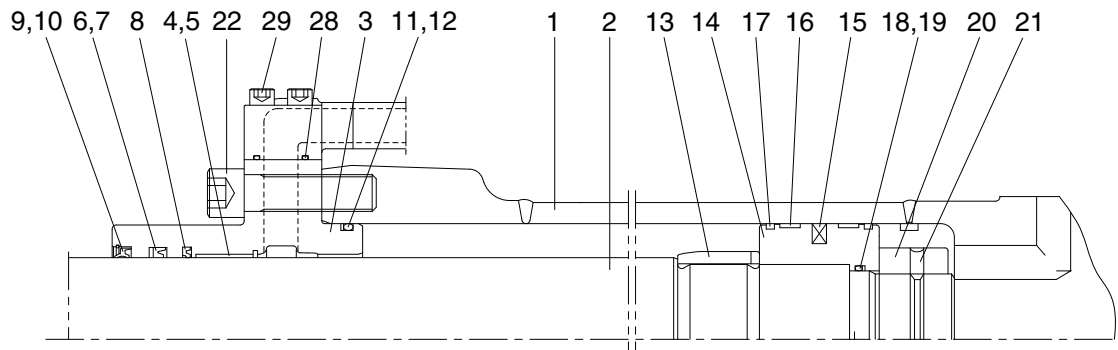

Internal detail

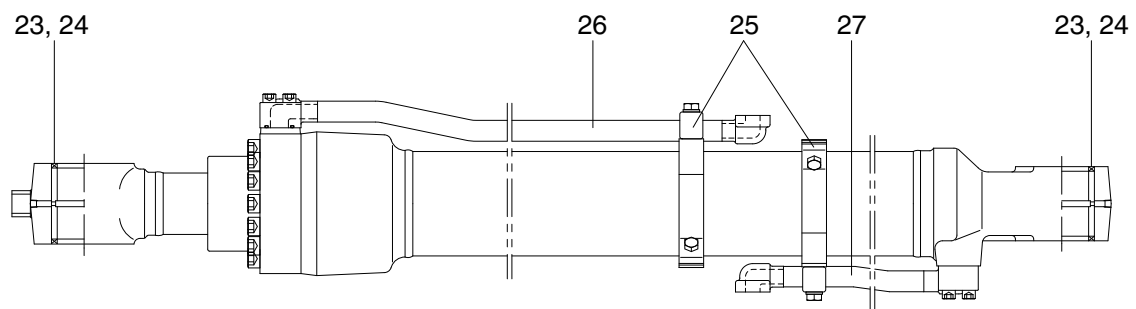

160WF8CY01

1	Tube assembly	11	O-ring	21	Hexagon socket set screw
2	Rod assembly	12	Back up ring	22	Hexagon socket head bolt
3	Gland	13	Cushion ring	23	Pin bushing
4	DD2 bushing	14	Piston	24	Dust seal
5	Snap ring	15	Piston seal	25	Band assembly
6	Rod seal	16	Wear ring	26	Pipe assembly-R
7	Back up ring	17	Dust ring	27	Pipe assembly-B
8	Buffer ring	18	O-ring	28	O-ring
9	Dust wiper	19	Back up ring	29	Hexagon socket head bolt
10	Snap ring	20	Lock nut		

CLICK HERE TO **DOWNLOAD** THE COMPLETE MANUAL

- Thank you very much for reading the preview of the manual.
- You can download the complete manual from: www.heydownloads.com by clicking the link below



- Please note: If there is no response to CLICKING the link, please download this PDF first and then click on it.

CLICK HERE TO **DOWNLOAD** THE COMPLETE MANUAL