

SECTION 1 GENERAL

Group 1 Safety Hints	1-1
Group 2 Specifications	1-9

SECTION 2 STRUCTURE AND FUNCTION

Group 1 Pump Device	2-1
Group 2 Main Control Valve	2-20
Group 3 Swing Device	2-47
Group 4 Travel Motor	2-58
Group 5 RCV Lever	2-64
Group 6 Accelerator Pedal	2-71
Group 7 Brake Pedal (Valve)	2-72
Group 8 Transmission	2-74
Group 9 Travel Control Valve	2-81
Group 10 Steering Valve	2-83
Group 11 Front Axle and Rear Axle	2-85

SECTION 3 HYDRAULIC SYSTEM

Group 1 Hydraulic Circuit	3-1
Group 2 Main Circuit	3-3
Group 3 Pilot Circuit	3-6
Group 4 Single Operation	3-17
Group 5 Combined Operation	3-32

SECTION 4 ELECTRICAL SYSTEM

Group 1 Component Location	4-1
Group 2 Electrical Circuit	4-3
Group 3 Electrical Component Specification	4-25
Group 4 Connectors	4-37

SECTION 5 MECHATRONICS SYSTEM

Group 1 Outline	5-1
Group 2 Mode selection System	5-3

CLICK HERE TO **DOWNLOAD** THE COMPLETE MANUAL

- Thank you very much for reading the preview of the manual.
- You can download the complete manual from: www.heydownloads.com by clicking the link below



- Please note: If there is no response to CLICKING the link, please download this PDF first and then click on it.

CLICK HERE TO **DOWNLOAD** THE COMPLETE MANUAL

TEMPERATURE

Fahrenheit-Centigrade Conversion.

A simple way to convert a fahrenheit temperature reading into a centigrade temperature reading or vice versa is to enter the accompanying table in the center or boldface column of figures.

These figures refer to the temperature in either Fahrenheit or Centigrade degrees.

If it is desired to convert from Fahrenheit to Centigrade degrees, consider the center column as a table of Fahrenheit temperatures and read the corresponding Centigrade temperature in the column at the left.

If it is desired to convert from Centigrade to Fahrenheit degrees, consider the center column as a table of Centigrade values, and read the corresponding Fahrenheit temperature on the right.

°C	°F	°C	°F	°C	°F	°C	°F	°C	°F	°C	°F
-40.4	-40	-40.0	-11.7	11	51.8	7.8	46	114.8	27.2	81	117.8
-37.2	-35	-31.0	-11.1	12	53.6	8.3	47	116.6	27.8	82	179.6
-34.4	-30	-22.0	-10.6	13	55.4	8.9	48	118.4	28.3	83	181.4
-31.7	-25	-13.0	-10.0	14	57.2	9.4	49	120.2	28.9	84	183.2
-28.9	-20	-4.0	-9.4	15	59.0	10.0	50	122.0	29.4	85	185.0
-28.3	-19	-2.2	-8.9	16	60.8	10.6	51	123.8	30.0	86	186.8
-27.8	-18	-0.4	-8.3	17	62.6	11.1	52	125.6	30.6	87	188.6
-27.2	-17	1.4	-7.8	18	64.4	11.7	53	127.4	31.1	88	190.4
-26.7	-16	3.2	-6.7	20	68.0	12.8	55	131.0	32.2	90	194.0
-26.1	-15	5.0	-6.7	20	68.0	12.8	55	131.0	32.2	90	194.0
-25.6	-14	6.8	-6.1	21	69.8	13.3	56	132.8	32.8	91	195.8
-25.0	-13	8.6	-5.6	22	71.6	13.9	57	134.6	33.3	92	197.6
-24.4	-12	10.4	-5.0	23	73.4	14.4	58	136.4	33.9	93	199.4
-23.9	-11	12.2	-4.4	24	75.2	15.0	59	138.2	34.4	94	201.2
-23.3	-10	14.0	-3.9	25	77.0	15.6	60	140.0	35.0	95	203.0
-22.8	-9	15.8	-3.3	26	78.8	16.1	61	141.8	35.6	96	204.8
-22.2	-8	17.6	-2.8	27	80.6	16.7	62	143.6	36.1	97	206.6
-21.7	-7	19.4	-2.2	28	82.4	17.2	63	145.4	36.7	98	208.4
-21.1	-6	21.2	-1.7	29	84.2	17.8	64	147.2	37.2	99	210.2
-20.6	-5	23.0	-1.1	35	95.0	21.1	70	158.0	51.7	125	257.0
-20.0	-4	24.8	-0.6	31	87.8	18.9	66	150.8	40.6	105	221.0
-19.4	-3	26.6	0	32	89.6	19.4	67	152.6	43.3	110	230.0
-18.9	-2	28.4	0.6	33	91.4	20.0	68	154.4	46.1	115	239.0
-18.3	-1	30.2	1.1	34	93.2	20.6	69	156.2	48.9	120	248.0
-17.8	0	32.0	1.7	35	95.0	21.1	70	158.0	51.7	125	257.0
-17.2	1	33.8	2.2	36	96.8	21.7	71	159.8	54.4	130	266.0
-16.7	2	35.6	2.8	37	98.6	22.2	72	161.6	57.2	135	275.0
-16.1	3	37.4	3.3	38	100.4	22.8	73	163.4	60.0	140	284.0
-15.6	4	39.2	3.9	39	102.2	23.3	74	165.2	62.7	145	293.0
-15.0	5	41.0	4.4	40	104.0	23.9	75	167.0	65.6	150	302.0
-14.4	6	42.8	5.0	41	105.8	24.4	76	168.8	68.3	155	311.0
-13.9	7	44.6	5.6	42	107.6	25.0	77	170.6	71.1	160	320.0
-13.3	8	46.4	6.1	43	109.4	25.6	78	172.4	73.9	165	329.0
-12.8	9	48.2	6.7	44	111.2	26.1	79	174.2	76.7	170	338.0
-12.2	10	50.0	7.2	45	113.0	26.7	80	176.0	79.4	172	347.0

GROUP 2 SPECIFICATIONS



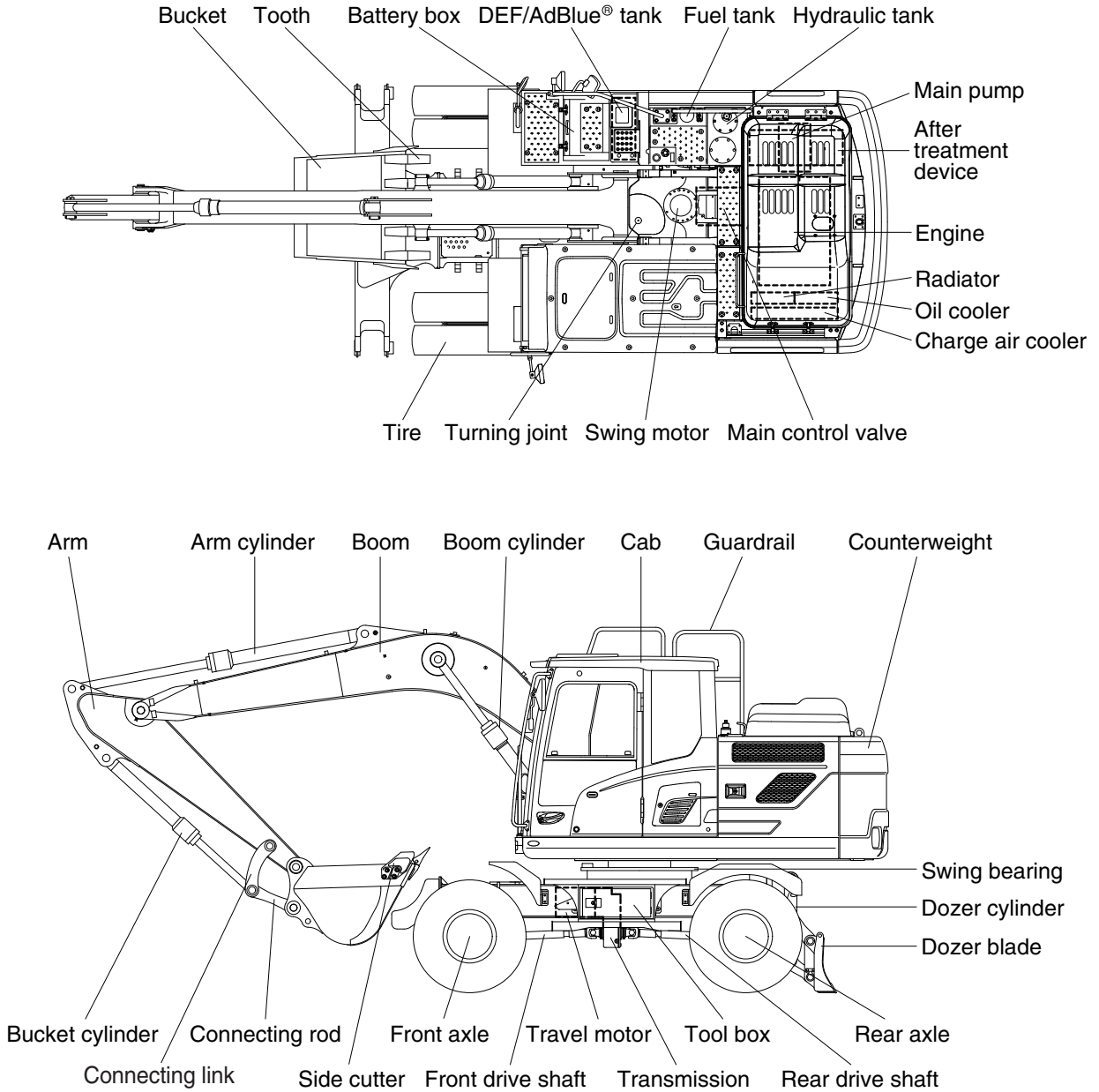





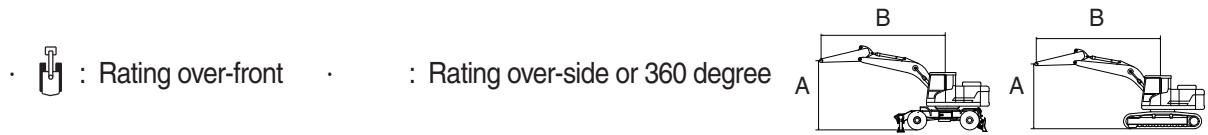

1. MAJOR COMPONENT



140WF2SP01









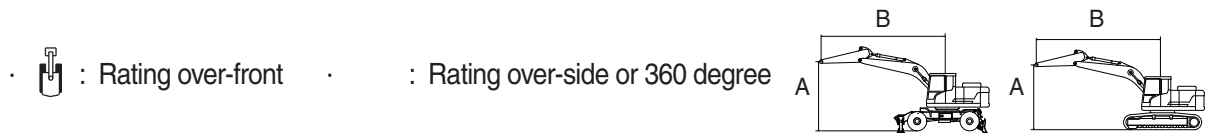

Model	Type	Boom	Arm	Counterweight	Shoe	Wheel	Dozer		Outrigger	
HW140	MONO BOOM	Length [mm]	Length [mm]	weight [kg]	width [mm]	width [mm]	Front	Rear	Front	Rear
		4600	2100	2200	-	500	-	Down	-	-



Lift-point height (A)		Lift-point radius (B)								At max. reach		
		1.5 m (4.9 ft)		3.0 m (9.8 ft)		4.5 m (14.8 ft)		6.0 m (19.7 ft)		Capacity		Reach
												m (ft)
6.0 m (19.7 ft)	kg					*3870	*3870			*3400	*3400	5.17
	lb					*8530	*8530			*7500	*7500	(17.0)
4.5 m (14.8 ft)	kg					*4230	*4230	*3740	2900	*3200	2820	6.10
	lb					*9330	*9330	*8250	6390	*7050	6220	(20.0)
3.0 m (9.8 ft)	kg					*5200	4390	3910	2840	*3240	2470	6.57
	lb					*11460	9680	8620	6260	*7140	5450	(21.5)
1.5 m (4.9 ft)	kg					5950	4170	3820	2750	3260	2370	6.66
	lb					13120	9190	8420	6060	7190	5220	(21.8)
Ground Line	kg			*6800	*6800	5820	4050	3760	2700	3420	2470	6.40
	lb			*14990	*14990	12830	8930	8290	5950	7540	5450	(21.0)
-1.5 m (-4.9 ft)	kg	*6280	*6280	*9720	7720	5800	4030			4020	2880	5.74
	lb	*13850	*13850	*21430	17020	12790	8880			8860	6350	(18.8)
-3.0 m (-9.8 ft)	kg			*7820	*7820	*5030	4160			*5020	4150	4.50
	lb			*17240	*17240	*11090	9170			*11070	9150	(14.8)

Model	Type	Boom	Arm	Counterweight	Shoe	Wheel	Dozer		Outrigger	
HW140	MONO BOOM	Length [mm]	Length [mm]	weight [kg]	width [mm]	width [mm]	Front	Rear	Front	Rear
		4600	2100	2200	-	500	-	Up	-	-









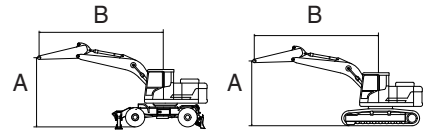

Lift-point height (A)		Lift-point radius (B)								At max. reach		
		1.5 m (4.9 ft)		3.0 m (9.8 ft)		4.5 m (14.8 ft)		6.0 m (19.7 ft)		Capacity		Reach
												m (ft)
6.0 m (19.7 ft)	kg					*3870	*3870			*3400	*3400	5.17
	lb					*8530	*8530			*7500	*7500	(17.0)
4.5 m (14.8 ft)	kg					*4230	*4230	*3740	2910	*3200	2820	6.10
	lb					*9330	*9330	*8250	6420	*7050	6220	(20.0)
3.0 m (9.8 ft)	kg					*5200	4390	3910	2840	*3240	2470	6.57
	lb					*11460	9680	8620	6260	*7140	5450	(21.5)
1.5 m (4.9 ft)	kg					5950	4180	3820	2760	3260	2370	6.66
	lb					13120	9220	8420	6080	7190	5220	(21.8)
Ground Line	kg			*6800	*6800	5820	4050	3760	2700	3420	2470	6.40
	lb			*14990	*14990	12830	8930	8290	5950	7540	5450	(21.0)
-1.5 m (-4.9 ft)	kg	*6280	*6280	*9720	7740	5800	4040			4020	2880	5.74
	lb	*13850	*13850	*21430	17060	12790	8910			8860	6350	(18.8)
-3.0 m (-9.8 ft)	kg			*7820	*7820	*5030	4170			*5020	4160	4.50
	lb			*17240	*17240	*11090	9190			*11070	9170	(14.8)

Model	Type	Boom	Arm	Counterweight	Shoe	Wheel	Dozer		Outrigger	
HW140	2-PIECE BOOM	Length [mm]	Length [mm]	weight [kg]	width [mm]	width [mm]	Front	Rear	Front	Rear
		5000	2100	2200	-	500	-	Down	-	-

 : Rating over-front

 : Rating over-side or 360 degree









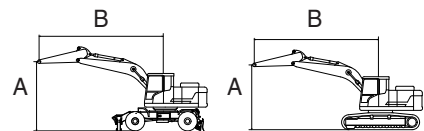

Lift-point height (A)		Lift-point radius (B)						At max. reach		
		3.0 m (9.8 ft)		4.5 m (14.8 ft)		6.0 m (19.7 ft)		Capacity		Reach
										m (ft)
7.5 m (24.6 ft)	kg lb							*4290 *9460	*4290 *9460	4.13 (13.6)
6.0 m (19.7 ft)	kg lb			*3820 *8420	*3820 *8420			*4060 *8950	3190 7030	5.68 (18.6)
4.5 m (14.8 ft)	kg lb	*5410 *11930	*5410 *11930	*4400 *9700	*4400 *9700	4010 8840	2910 6420	3460 7630	2510 5530	6.54 (21.5)
3.0 m (9.8 ft)	kg lb			*5540 *12210	4330 9550	3910 8620	2820 6220	3080 6790	2220 4890	6.97 (22.9)
1.5 m (4.9 ft)	kg lb			5890 12990	4090 9020	3790 8360	2710 5970	2970 6550	2140 4720	7.06 (23.2)
Ground Line	kg lb			5750 12680	3960 8730	3720 8200	2640 5820	3100 6830	2220 4890	6.82 (22.4)
-1.5 m (-4.9 ft)	kg lb	*10390 *22910	7600 16760	5740 12650	3950 8710	3720 8200	2650 5840	3560 7850	2540 5600	6.21 (20.4)

Model	Type	Boom	Arm	Counterweight	Shoe	Wheel	Dozer		Outrigger	
HW140	2-PIECE BOOM	Length [mm]	Length [mm]	weight [kg]	width [mm]	width [mm]	Front	Rear	Front	Rear
		5000	2100	2200	-	500	-	Up	-	-

 : Rating over-front

 : Rating over-side or 360 degree



Lift-point height (A)		Lift-point radius (B)						At max. reach		
		3.0 m (9.8 ft)		4.5 m (14.8 ft)		6.0 m (19.7 ft)		Capacity		Reach
										m (ft)
7.5 m (24.6 ft)	kg lb							*4290 *9460	*4290 *9460	4.13 (13.6)
6.0 m (19.7 ft)	kg lb			*3820 *8420	*3820 *8420			*4060 *8950	3200 7050	5.68 (18.6)
4.5 m (14.8 ft)	kg lb	*5410 *11930	*5410 *11930	*4400 *9700	*4400 *9700	4010 8840	2910 6420	3460 7630	2520 5560	6.54 (21.5)
3.0 m (9.8 ft)	kg lb			*5540 *12210	4340 9570	3910 8620	2820 6220	3080 6790	2230 4920	6.97 (22.9)
1.5 m (4.9 ft)	kg lb			5890 12990	4100 9040	3790 8360	2720 6000	2970 6550	2140 4720	7.06 (23.2)
Ground Line	kg lb			5750 12680	3970 8750	3720 8200	2650 5840	3100 6830	2220 4890	6.82 (22.4)
-1.5 m (-4.9 ft)	kg lb	*10390 *22910	7620 16800	5740 12650	3960 8730	3720 8200	2650 5840	3560 7850	2540 5600	6.21 (20.4)

9) CYLINDER

Item		Specification	
Boom cylinder	Bore dia × Rod dia × Stroke	Ø 105 × Ø 75 × 1075mm	
	Cushion	Extend only	
Arm cylinder	Bore dia × Rod dia × Stroke	Ø 115 × Ø 80 × 1138mm	
	Cushion	Extend and retract	
Bucket cylinder	Bore dia × Rod dia × Stroke	Ø 100 × Ø 70 × 840mm	
	Cushion	Extend only	
Dozer cylinder	Rear	Bore dia × Rod dia × Stroke	Ø 100 × Ø 60 × 236mm
	Front	Bore dia × Rod dia × Stroke	Ø 100 × Ø 60 × 240mm
	Cushion	-	
Outrigger cylinder	Bore dia × Rod dia × Stroke	Ø 110 × Ø 65 × 446mm	
	Cushion	-	
Adjust cylinder	Bore dia × Rod dia × Stroke	Ø 145 × Ø 90 × 613mm	
	Cushion	-	
Adjust boom cylinder	Bore dia × Rod dia × Stroke	Ø 105 × Ø 75 × 975mm	
	Cushion	Extend only	

10) BUCKET

Item	Capacity		Tooth quantity	Width	
	SAE heaped	CECE heaped		Without side cutter	With side cutter
Standard	※ 0.58 m ³ (0.76 yd ³)	0.50 m ³ (0.65 yd ³)	5	1030 mm (40.6")	1130 mm (44.5")
Option	0.23 m ³ (0.30 yd ³)	0.20 m ³ (0.26 yd ³)	3	520 mm (20.5")	620 mm (24.4")
	0.40 m ³ (0.52 yd ³)	0.35 m ³ (0.46 yd ³)	4	760 mm (29.9")	860 mm (33.9")
	0.46 m ³ (0.60 yd ³)	0.40 m ³ (0.52 yd ³)	4	850 mm (33.5")	950 mm (37.4")
	0.52 m ³ (0.68 yd ³)	0.45 m ³ (0.59 yd ³)	5	935 mm (36.8")	1035 mm (40.7")
	0.65 m ³ (0.85 yd ³)	0.55 m ³ (0.72 yd ³)	5	1110 mm (43.7")	1210 mm (47.6")
	0.71 m ³ (0.93 yd ³)	0.60 m ³ (0.78 yd ³)	5	1205 mm (47.4")	1305 mm (51.4")
	◎ 0.55 m ³ (0.72 yd ³)	0.45 m ³ (0.59 yd ³)	-	1800 mm (70.9")	-
	★ 0.45 m ³ (0.59 yd ³)	0.40 m ³ (0.52 yd ³)	-	1520 mm (59.8")	-

◎ : Slope finishing bucket

★ : Ditch cleaning bucket

(3) Valve block group

The valve block group consists of valve block (312), valve plate (313) and valve plate pin (885).

The valve plate having two melon-shaped ports is fixed to the valve block and feeds and collects oil to and from the cylinder block.

The oil changed over by the valve plate is connected to an external pipeline by way of the valve block.

Now, if the drive shaft is driven by a prime mover (electric motor, engine, etc), it rotates the cylinder block via a spline linkage at the same time. If the swash plate is tilted as in Fig (previous page) the pistons arranged in the cylinder block make a reciprocating motion with respect to the cylinder block, while they revolve with the cylinder block.

If you pay attention to a single piston, it performs a motion away from the valve plate (oil sucking process) within 180 degrees, and makes a motion towards the valve plate (or oil discharging process) in the rest of 180 degrees. When the swash plate has a tilting angle of zero, the piston makes no stroke and discharges no oil.

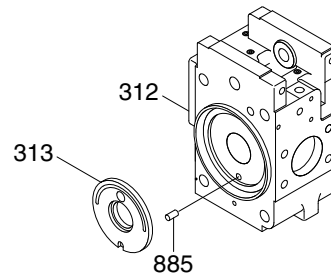

21092MP07

(3) Power shift control

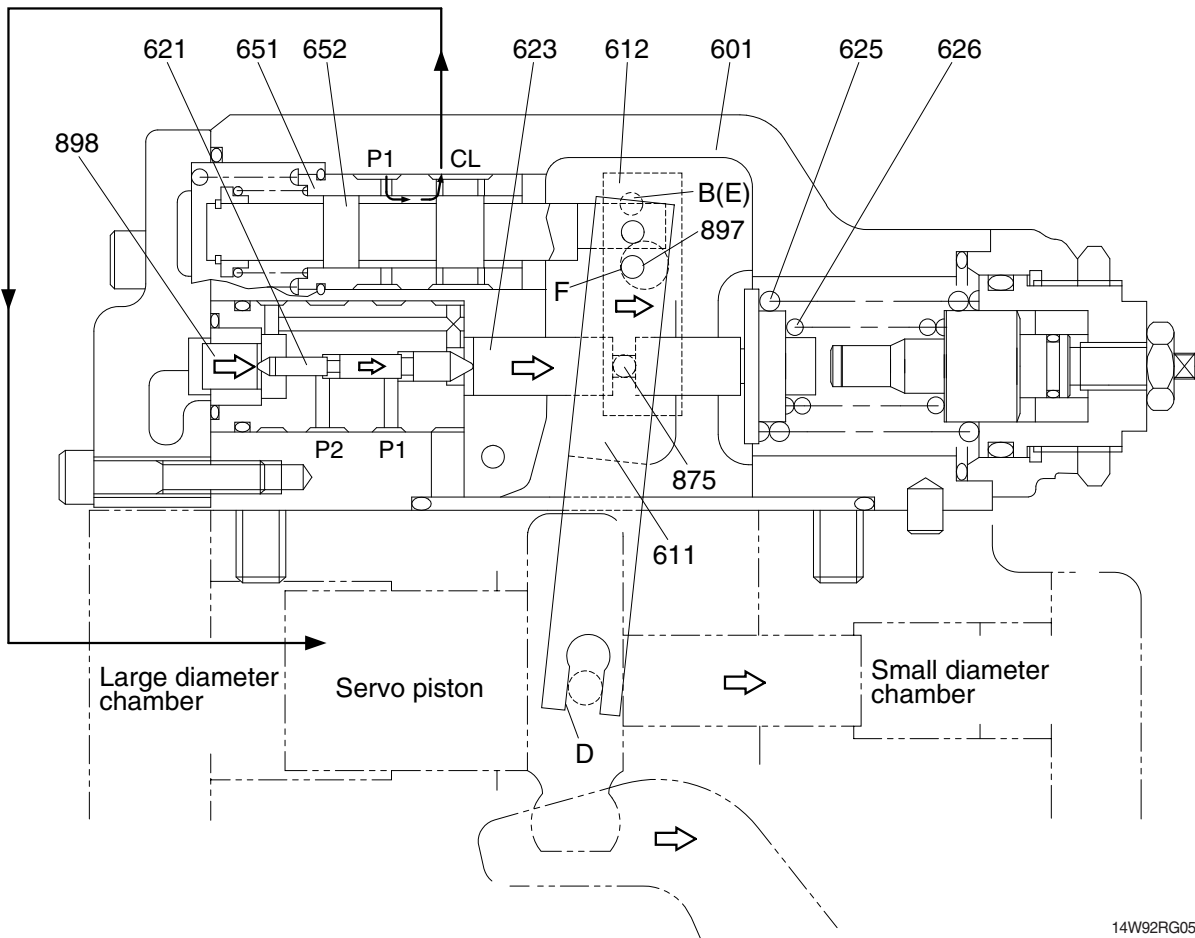

14W92RG05

The set horsepower valve is shifted by varying the command current level of the proportional pressure reducing valve attached to the pump.

Only one proportional pressure reducing valve is provided.

However, the secondary pressure P_f (power shift pressure) is admitted to the horsepower control section of each pump regulator through the pump's internal path to shift it to the same set horsepower level.

This function permits arbitrary setting of the pump output power, thereby providing the optimum power level according to the operating condition.

The power shift pressure P_f controls the set horsepower of the pump to a desired level, as shown in the figure.

As the power shift pressure P_f rises, the compensating rod (623) moves to the right via the pin (898) and compensating piston (621).

This decreases the pump tilting angle and then the set horsepower in the same way as explained in the overload preventive function of the horsepower control. On the contrary, the set horsepower rises as the power shift pressure P_f falls.

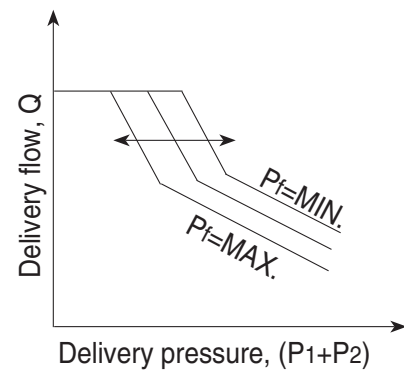

(2) BOOM DOWN OPERATION

During the boom lowering operation, the pilot pressure from RCV is supplied to the port Pb20 of the spring opposite side and shifts the boom 1 spool in the right direction.

The bypass passage is shut off by the movement of the boom 1 spool and the hydraulic fluid from the pump A2 enters the parallel passage and is directed to the port B2 through the load check. Following this, it flows into the rod side of the boom cylinder.

At the same time, the return flow from the head side of the boom cylinder returns to the port A2 and boom holding valve. And it is directed to the hydraulic oil tank through opened tank passage by movement of the boom 1 spool.

Meanwhile some of return flow is directed to P1 parallel passage through the internal passage of the boom 1 spool. (boom regeneration)

In this case, the holding valve is open condition, for details of the boom holding valve, see page following page.

During the boom lowering operation, the fluid from A1 pump is not summation.

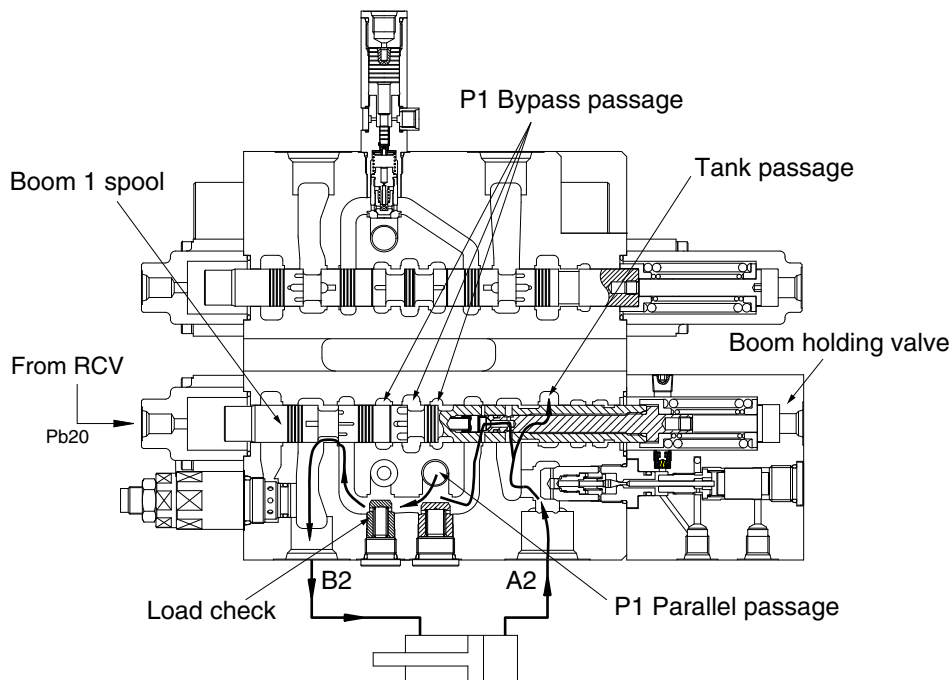

1609A2MC26

(2) ARM OUT OPERATION

During arm out operation, the pilot secondary pressure from RCV is supplied to the port Pd40 of spring side and shifts arm 1 spool in the left direction.

The bypass passage is shut off by the movement of the arm 1 spool and the hydraulic fluid from pump A1 flows into arm 1 spool through the P2 parallel passage. Then it enters into the arm cylinder rod side through the load check, bridge passage, arm holding valve and the port D4.

Also, the pilot secondary pressure from RCV is supplied to the port Pd41 of spring side and shifts arm 2 spool in the left direction.

The bypass passage is shut off by the movement of the arm 2 spool and some of the hydraulic fluid from pump A2 bypassed through bypass notch. The rest of hydraulic fluid from pump A2 flows into the arm summation passage through P1 parallel passage, the check valve, arm 2 spool and boom 2 spool.

Then it enters into the arm cylinder rod side with the fluid from the arm 1 spool.

The return flow from the arm cylinder head side returns to the hydraulic tank through the port C4, the arm 1 spool and tank passage.

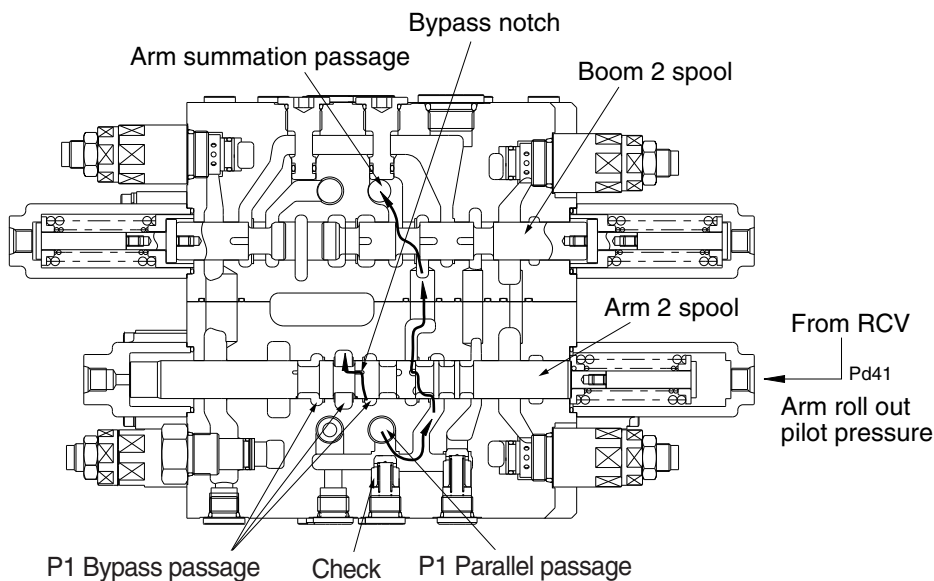
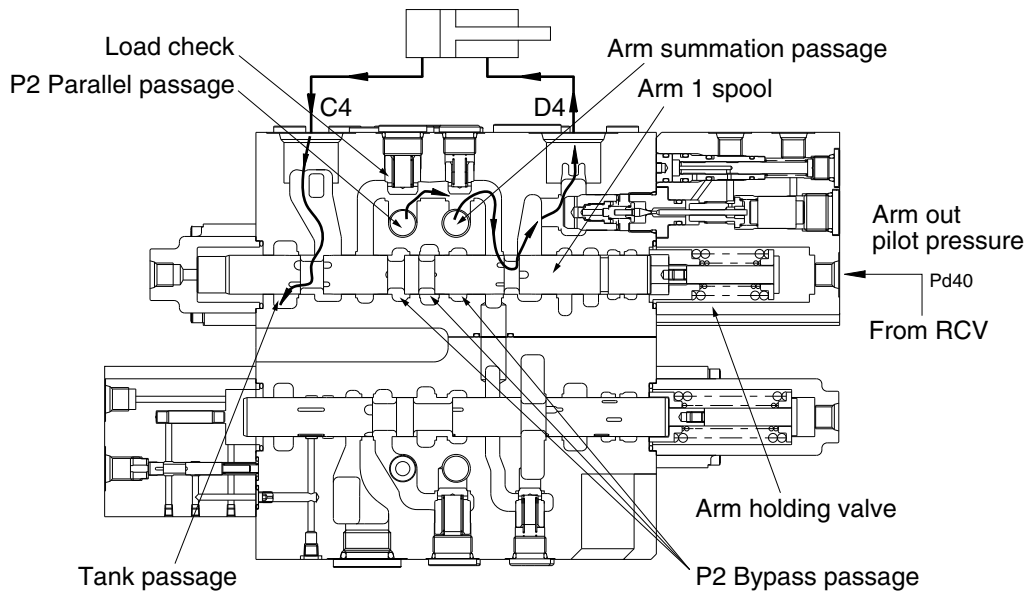

1609A2MC23

1) SWING MOTOR

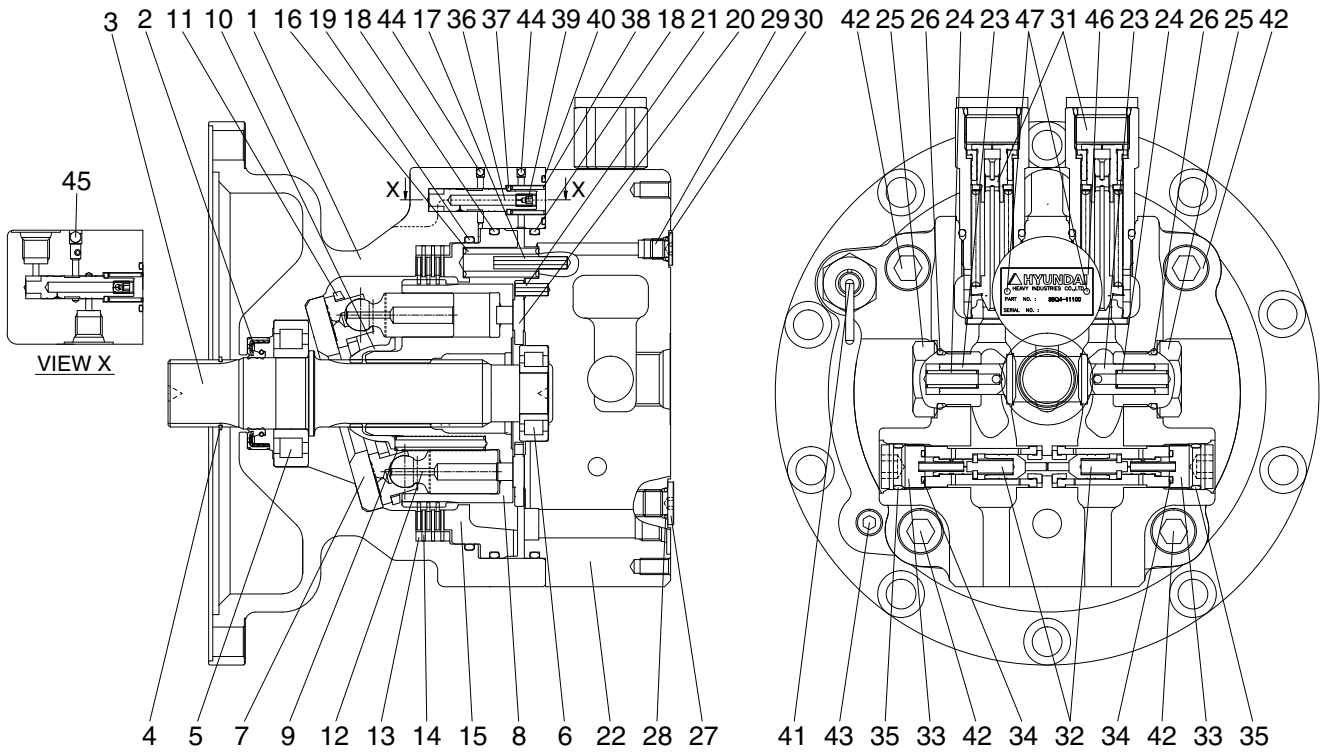

125LCR2SM22

- | | | | | | |
|----|----------------|----|--------------------------|----|------------------------|
| 1 | Casing | 17 | Spring pin | 33 | Plug |
| 2 | Oil seal | 18 | O-ring | 34 | O-ring |
| 3 | Shaft | 19 | O-ring | 35 | O-ring |
| 4 | Snap ring | 20 | Valve plate | 36 | Time delay valve spool |
| 5 | Roller bearing | 21 | Spring pin | 37 | Spring seat |
| 6 | Roller bearing | 22 | Valve casing | 38 | Spring |
| 7 | Swash plate | 23 | Check valve | 39 | Restrictor |
| 8 | Cylinder block | 24 | Spring | 40 | O-ring |
| 9 | Spring | 25 | Plug | 41 | Level gauge assy |
| 10 | Ball guide | 26 | O-ring | 42 | Socket bolt |
| 11 | Retainer plate | 27 | Plug | 43 | Plug |
| 12 | Piston assy | 28 | O-ring | 44 | Expander |
| 13 | Friction plate | 29 | Plug | 45 | Expander |
| 14 | Separate plate | 30 | O-ring | 46 | Name plate |
| 15 | Parking piston | 31 | Relief valve assy | 47 | Rivet |
| 16 | Spring | 32 | Anti-rotating valve assy | | |

GROUP 4 TRAVEL MOTOR

1. CONSTRUCTION

Travel motor consists motor unit, regulator and counter balance valve.

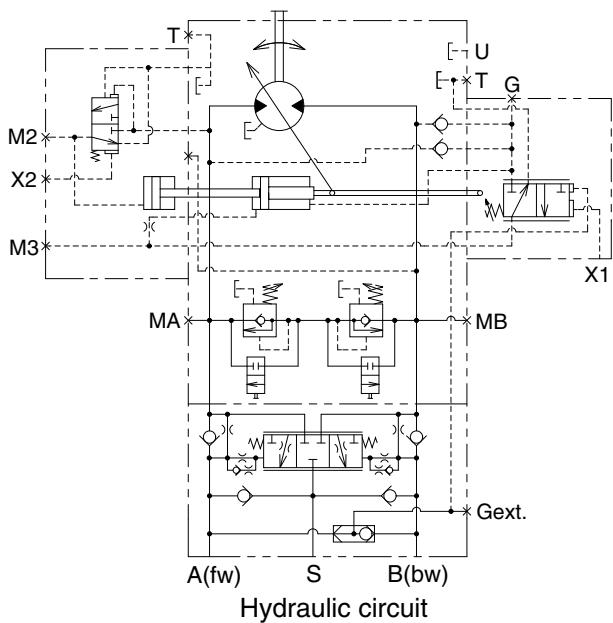
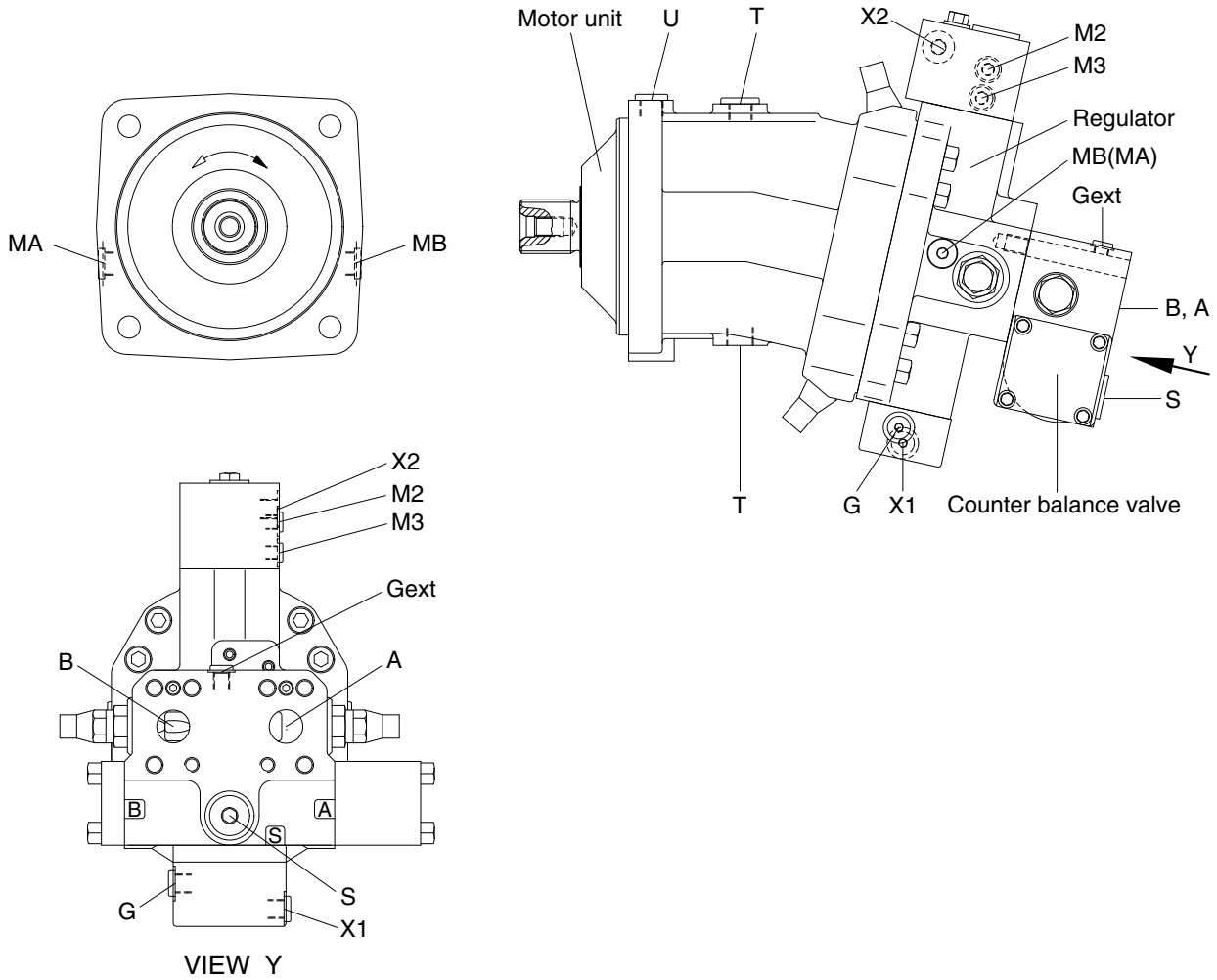

140W9A2TR01

Port	Port name	Port size
A, B	Main port	SAE 1"
G	N.A	M14 × 1.5-12
M1	Gauge port	M14 × 1.5-12
X1	Pilot pressure port	M14 × 1.5-12
X2	Pilot pressure port	M14 × 1.5-11.5
T	Drain port	PF 1/2-16
U	Flushing port	PF 1/2-16
S	Make up port	M27 × 2.0-14
MA, MB	Gauge port	M18 × 1.5-12
M2, M3	Gauge port	M10 × 1.0-8
Gext	Brake release port	M12 × 1.5-12.5

3) HIGH SPEED (forward & reverse)

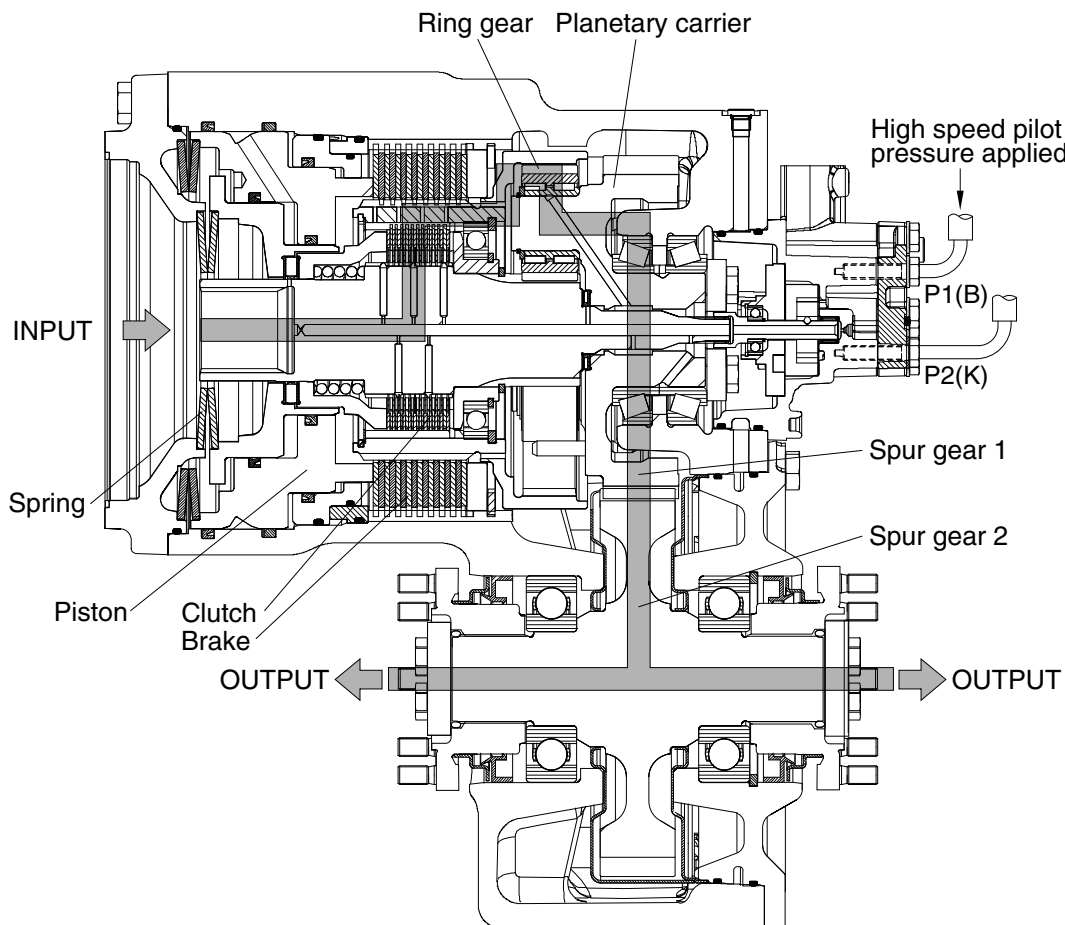

14W7A2TM05

In high speed operation, the clutch is held closed under spring pressure and the brake is hydraulically opened.

When a gear shift occurs-for example from high speed to low speed gear- the oil from the brake piston space is fed back to the tank through a restrictor (change over check valve) due to the spring pressure acting on the brake piston. At the same time the clutch is filled with oil and opened. Required oil flow is necessary for the transmission control to ensure the clutch is open before the brake begins to transmit torque.

A shift modulation valve is also integrated in the transmission. This modulates the pressure sequence at the brake during an upshift in order to achieve good shift quality.

The gear shift equipment also has the function of a parking brake. When the brake is operated-for example with high speed gear engaged-the clutch is closed and is statically loaded.

SECTION 3 HYDRAULIC SYSTEM

Group 1 Hydraulic Circuit	3-1
Group 2 Main Circuit	3-3
Group 3 Pilot Circuit	3-6
Group 4 Single Operation	3-17
Group 5 Combined Operation	3-32

4. SWING PARKING BRAKE RELEASE

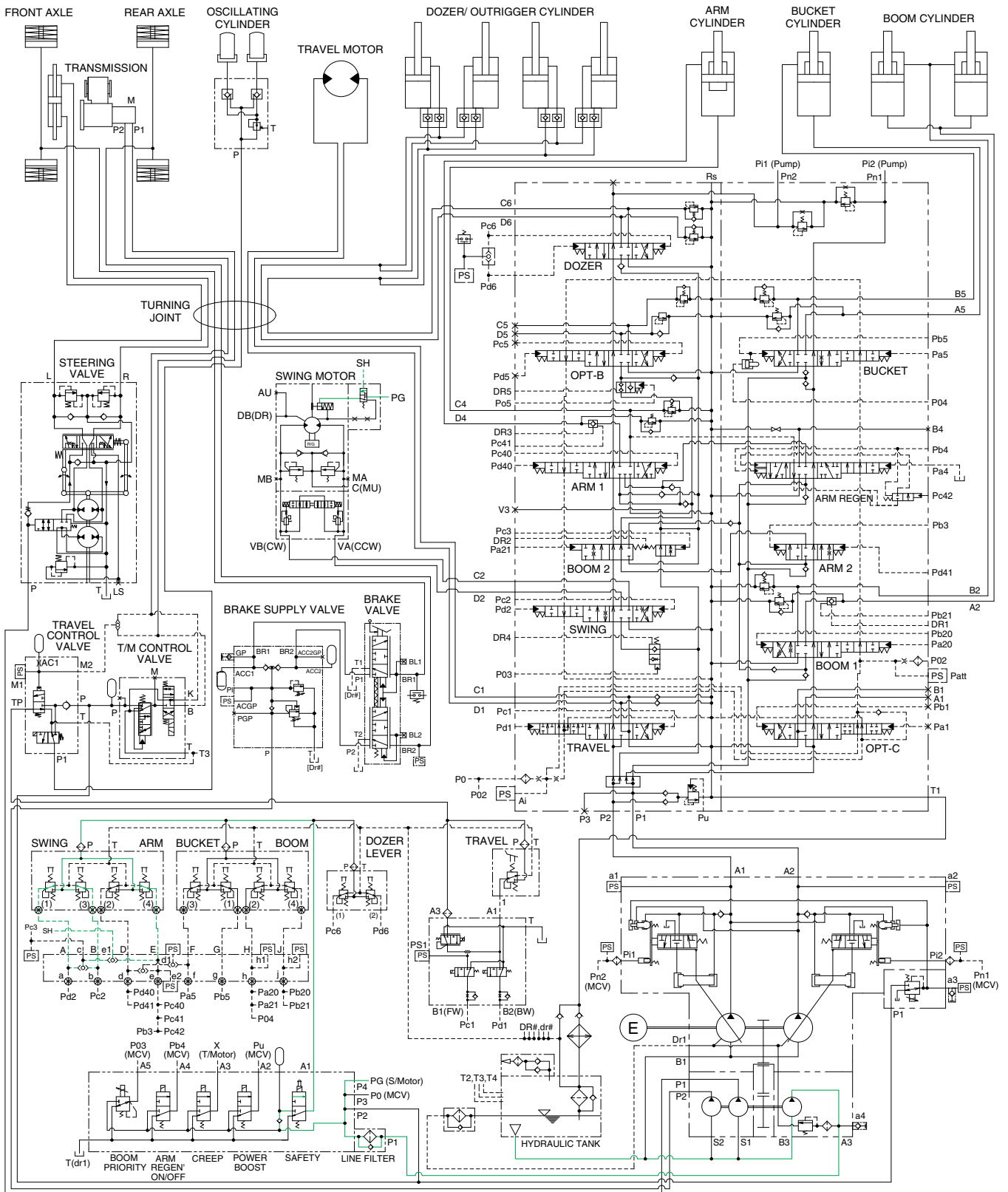

140WF3HC05A

When the swing control lever or arm in control lever is tilted, the pilot oil flows into SH port through main control valve. This pressure move spool so, discharged oil from pilot pump flows into swing motor PG port. This pressure is applied to swing motor disc, thus the brake released.

When the the swing control lever and arm in control lever are set in the neutral position, oil in the swing motor disc cylinder is drained, thus the brake is applied.

4. ARM OUT OPERATION

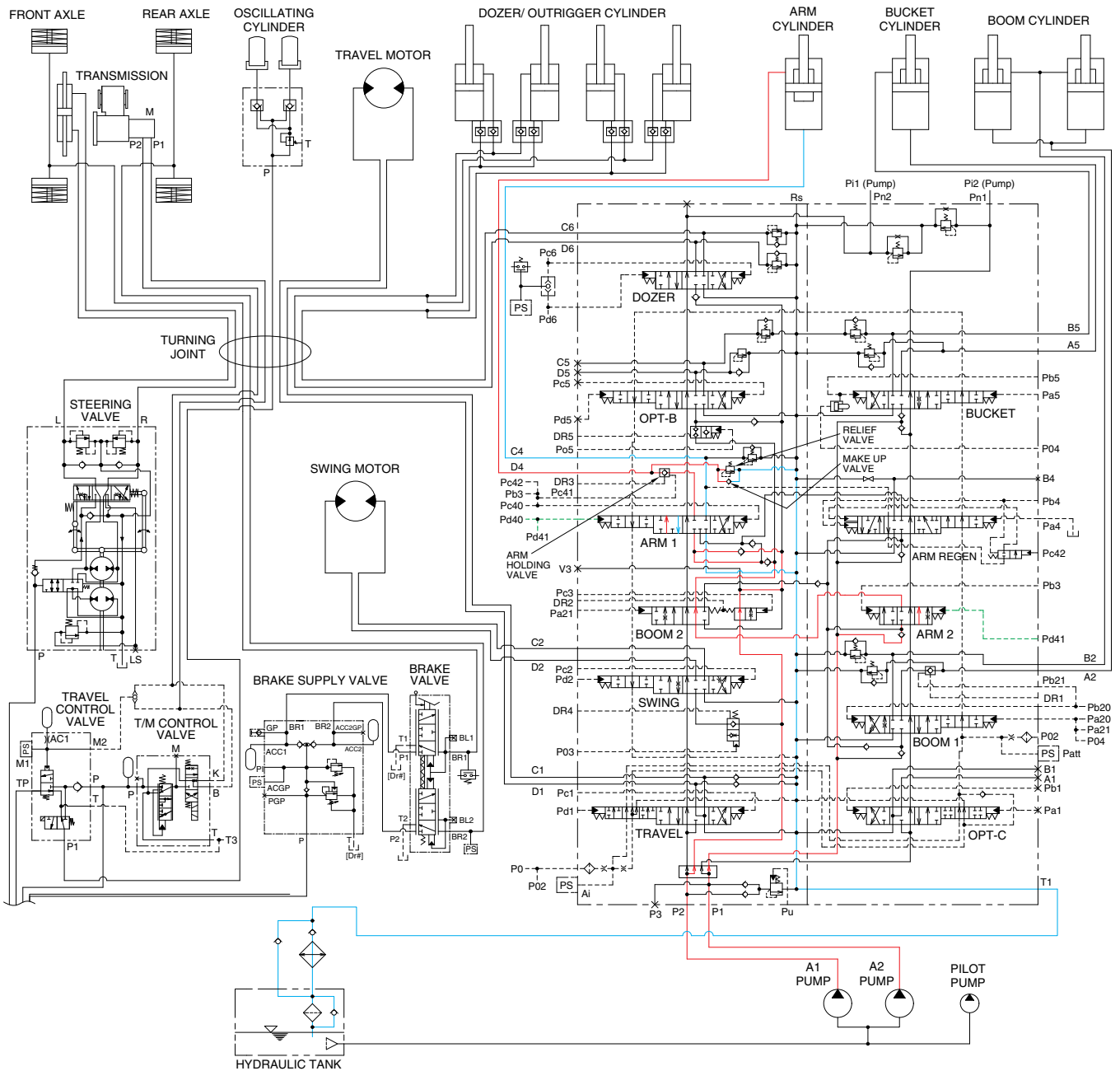

140WF3HC13A

When the left control lever is pushed forward, the arm spools in the main control valve are moved to the arm out position by the pilot oil pressure from the remote control valve.

The oil from the A1 and A2 pump flows into the main control valve and then goes to the small chamber of arm cylinder. At the same time, the oil from the large chamber of arm cylinder returns to the hydraulic oil tank through the arm 1 spool in the main control valve. When this happens, the arm rolls out. The cavitation which will happen to the rod side of the arm cylinder is also prevented by the make-up valve in the main control valve. When the arm is roll out and the control lever is returned to neutral position, the circuit for the holding pressure at the rod side of the arm cylinder is closed by the arm holding valve. This prevent the hydraulic drift of arm cylinder.

12. STEERING CIRCUIT OPERATION

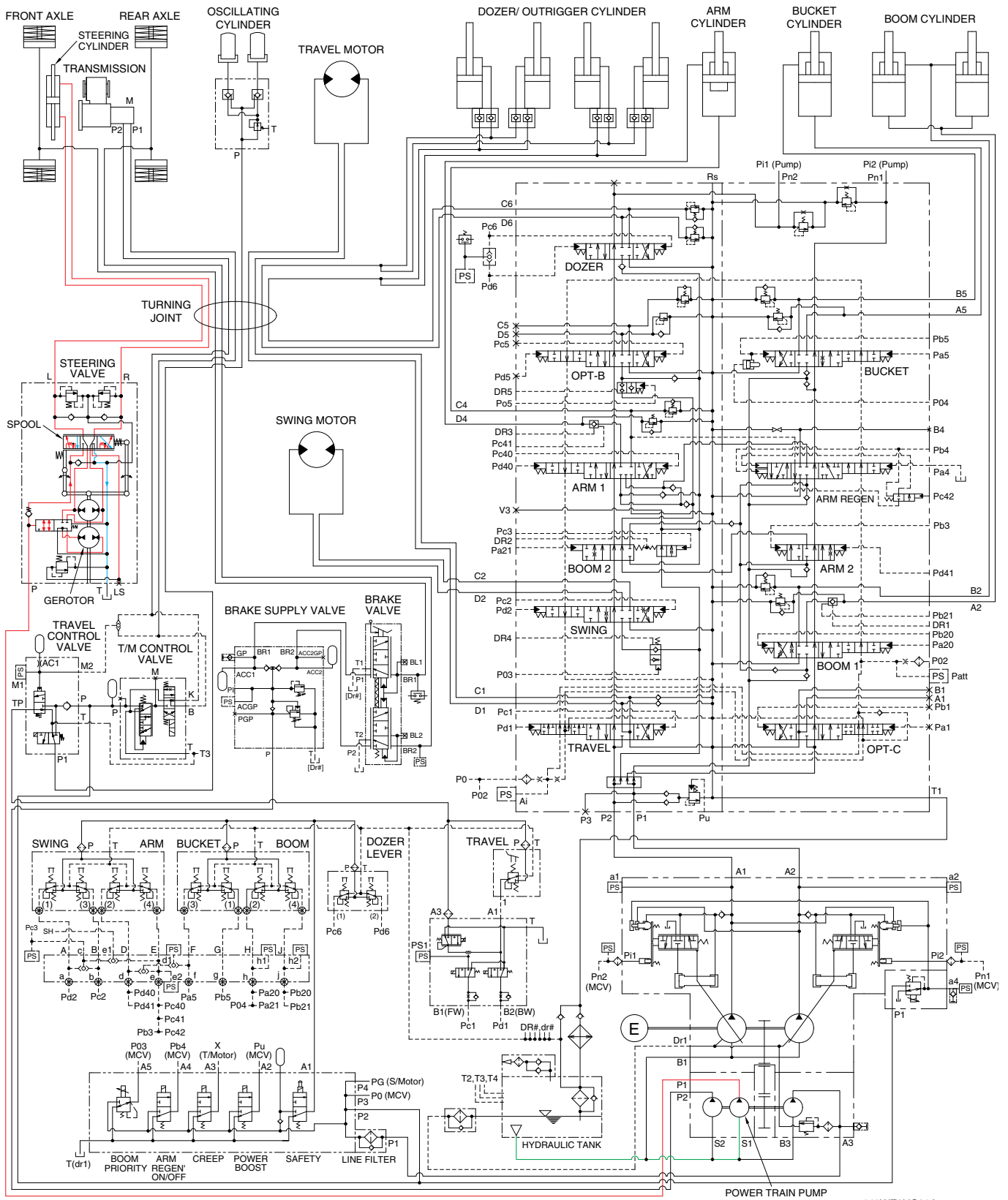

When the steering wheel is turned to the left or right, the spool within the steering valve turns left or right hand direction : Because the spool is connected with steering column.

At this time, the oil discharged from the transmission pump (P1) flows into steering cylinder through spool and gerotor within the steering valve.

Then the steering direction is applied.

STARTING CIRCUIT (SERIAL NO. : -#0507)

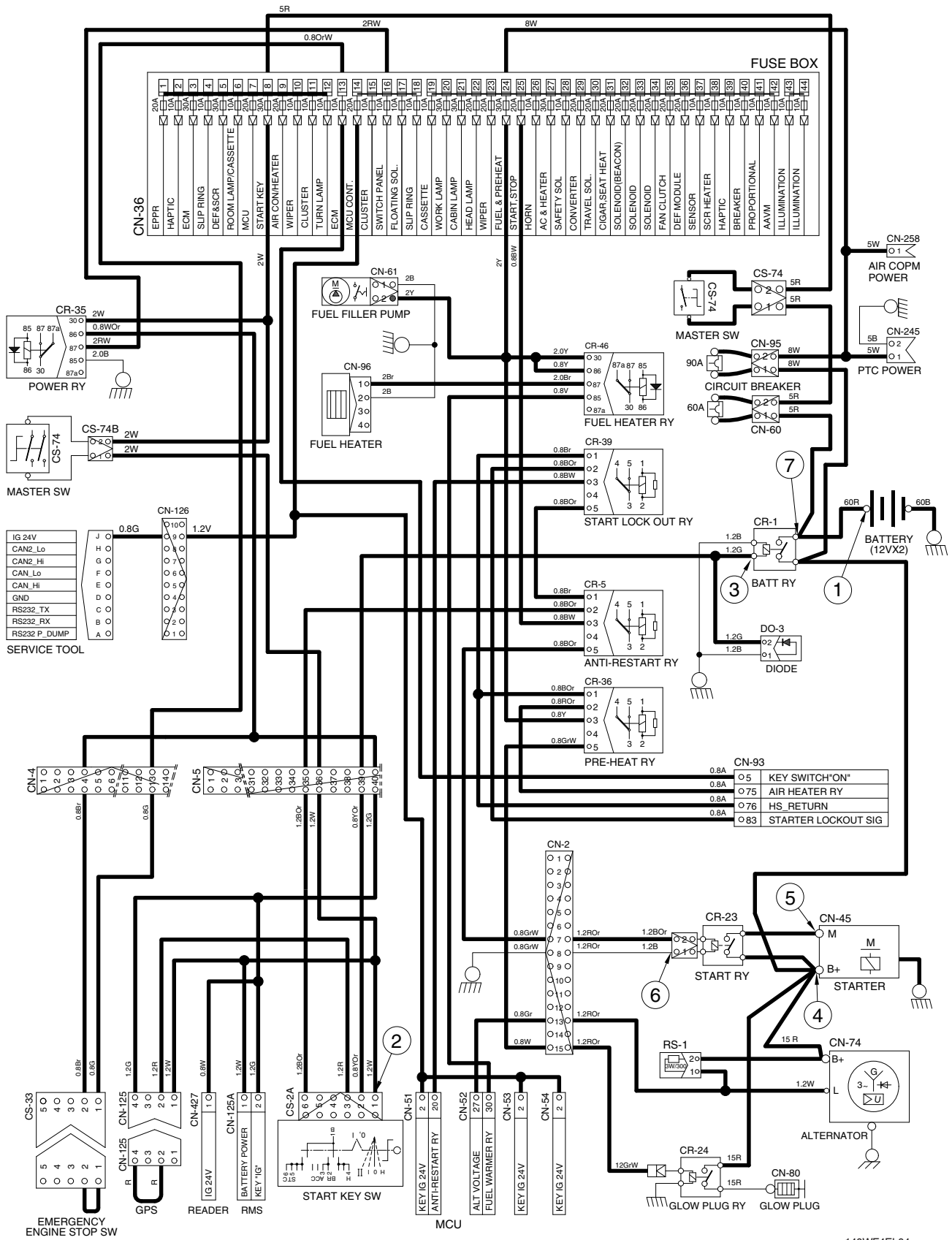

COMBINATION LAMP CIRCUIT (SERIAL NO. : -#0507)

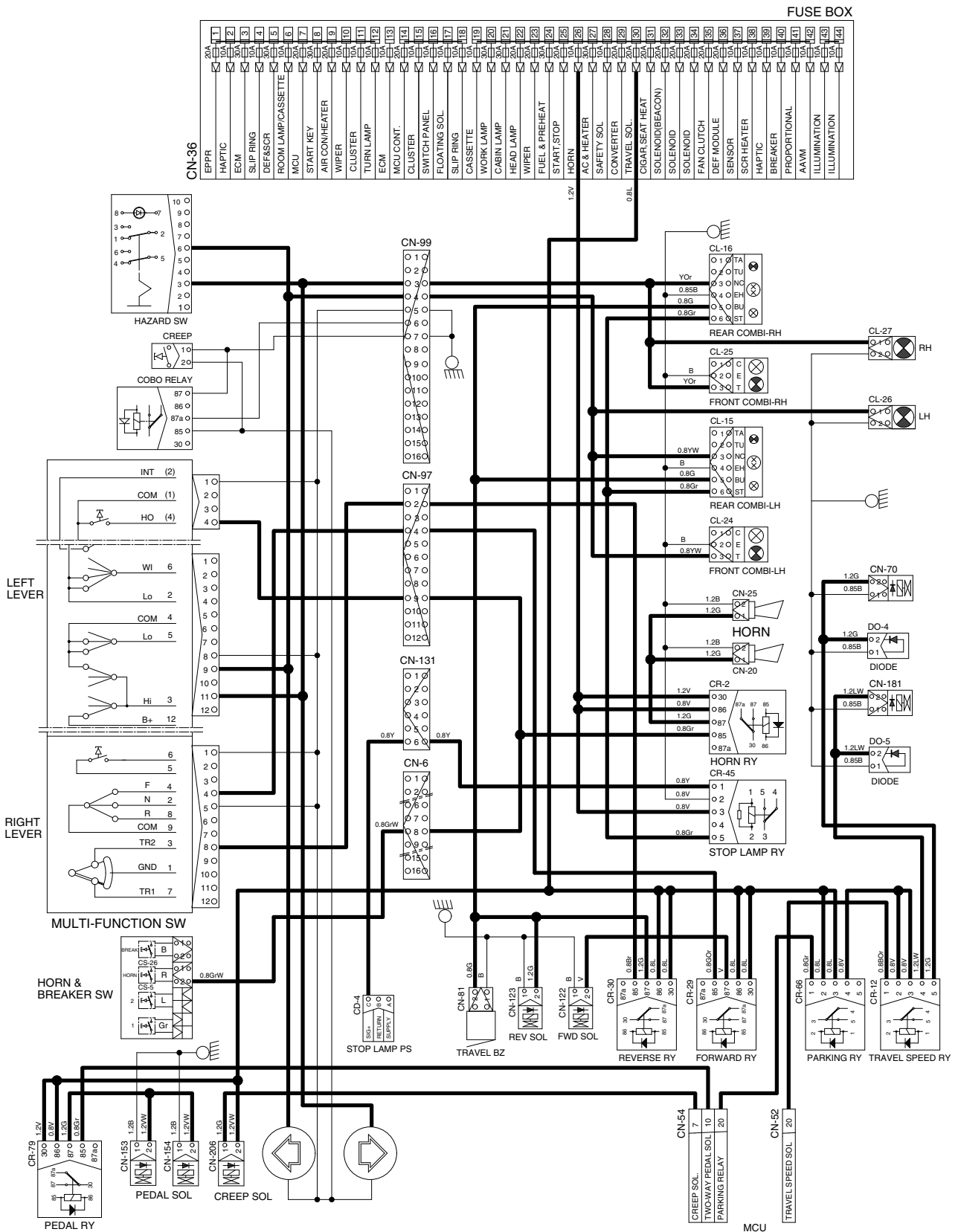

140WF4EL10

MONITORING CIRCUIT (SERIAL NO. : #0508-)

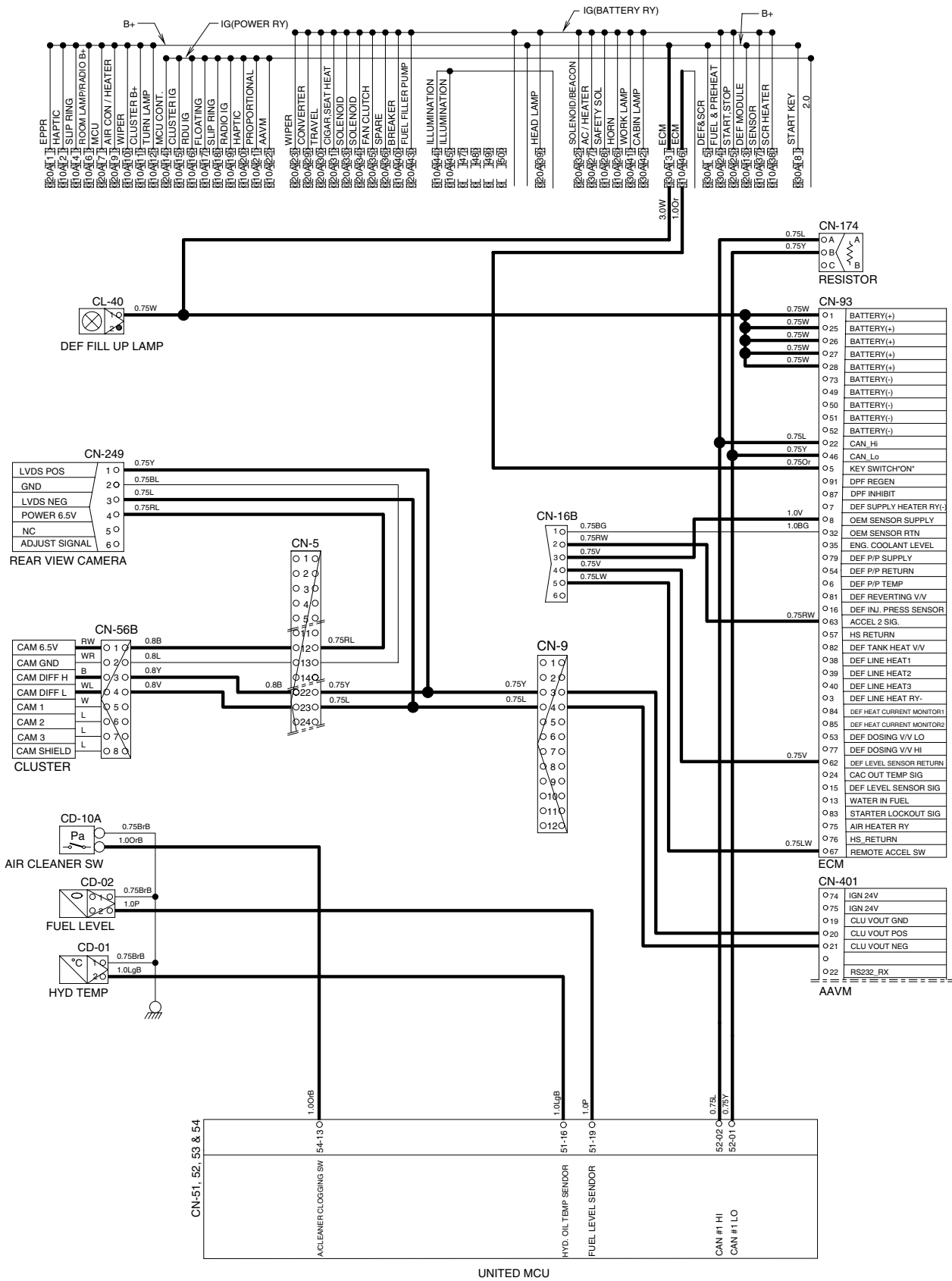

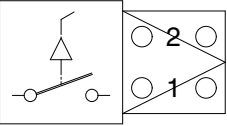
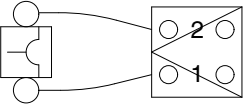
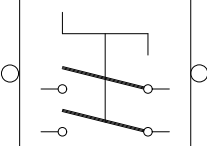
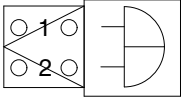
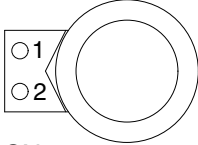
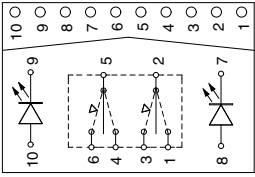
Part name	Symbol	Specifications	Check
Breaker selection switch	 <p>CS-26A</p>	-	-
Circuit breaker	 <p>CN-60 CN-95</p>	CN-60 : 60A CN-95 : 90A	※ Check disconnection Normal : 0Ω (connect ring terminal and check resist between terminal 1 and 2)
Master switch	 <p>CS-74B</p>	6-36V	※ Check disconnection Normal : 0.1Ω
Quick clamp buzzer	 <p>CN-113</p>	24V 200mA 107 ± 4dB	-
Socket	 <p>CN-139</p>	12V 10A	-
SCR switch	 <p>CS-100</p>	24V 8A	※ Check contact Normal OFF : ∞Ω (for terminal 2-1, 2-3, 4-5, 5-6)

(SERIAL NO. : -#0507)

Connector number	Type	No. of pin	Destination	Connector part No.	
				Female	Male
CS-108	CARLING	10	Auto grease switch	VC2-01	-
CS-111	CARLING	10	Boom floating switch	VC2-01	-
CS-250	-	2	Seat belt switch	-	-
· Light					
CL-1	KET	3	Room lamp	MG651032	-
CL-2	AMP	1	Cigar lighter	S822-014002	S822-114002
CL-3	-	3	Head lamp-LH	S810-003702	-
CL-4	-	3	Head lamp-RH	S810-003702	-
CL-5	DEUTSCH	2	Work lamp-LH	DT06-2S-EP06	-
CL-6	DEUTSCH	2	Work lamp-RH	DT06-2S-EP06	-
CL-7	SHUR	1	Beacon lamp	S822-014002	S822-114002
CL-8	DEUTSCH	2	Cab light-LH	DT06-2S-EP06	DT04-2P
CL-9	DEUTSCH	2	Cab light-RH	DT06-2S-EP06	DT04-2P
CL-10	DEUTSCH	2	Cab light-RH	DT06-2S-EP06	DT04-2P
CL-15	AMP	6	Rear combination lamp-LH	PB625-06027	-
CL-16	AMP	6	Rear combination lamp-RH	PB625-06027	-
CL-21	KET	2	Number plate lamp	-	S814-102000
CL-24	AMP	3	Front combination lamp-LH	S816-003002	-
CL-24	DEUTSCH	2	Rear work lamp	DT06-2S-EP06	DT04-2P-E005
CL-25	AMP	3	Front combination lamp-RH	S816-003002	-
CL-26	-	2	Side marker-LH	S816-002002	-
CL-27	-	3	Side marker-RH	S816-002002	-
CL-40	DEUTSCH	2	DEF/AdBlue® lamp	DT06-2S-EP06	-
CL-41	DEUTSCH	2	DEF/AdBlue® Fill up warning lamp	DT06-2S-EP06	-
· Sensor, sendor					
CD-1	AMP	2	Hydraulic oil temp sender	85202-1	-
CD-2	DEUTSCH	2	Fuel level sender	DT06-2S-EP06	-
CD-3	DEUTSCH	3	Brake oil pressure sensor	DT06-3S-EP06	-
CD-4	DEUTSCH	3	Stop lamp pressure sensor	DT06-3S-EP06	-
CD-5	DEUTSCH	3	Transmission oil pressure sensor	DT06-3S-EP06	-
CD-6	DEUTSCH	3	Travel pressure sensor	DT06-3S-EP06	-
CD-7	DEUTSCH	3	Working pressure sensor	DT06-3S-EP06	-
CD-9	DEUTSCH	3	Arm in pressure sensor	DT06-3S-EP06	-
CD-10	SUMITOMO	4	PRS temperature sensor	6098-0144	-
CD-10	AMP	2	Air cleaner switch	85202-1	-
CD-16	AMP	3	Water level sensor	1211-0293	-
CD-24	DEUTSCH	3	Swing pressure sensor	DT06-3S-EP06	-
CD-31	DEUTSCH	3	Overload pressure sensor	DT06-3S-EP06	-

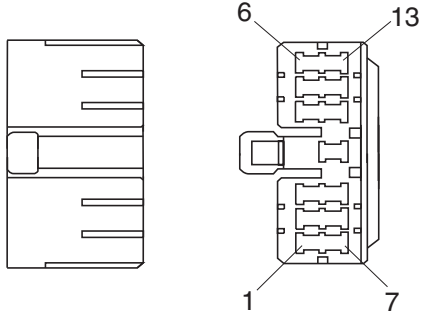
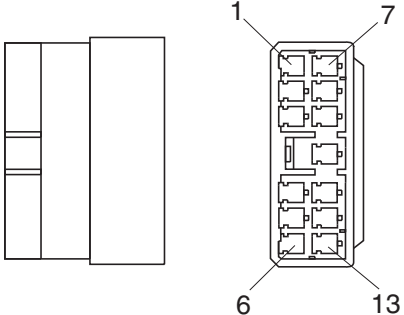
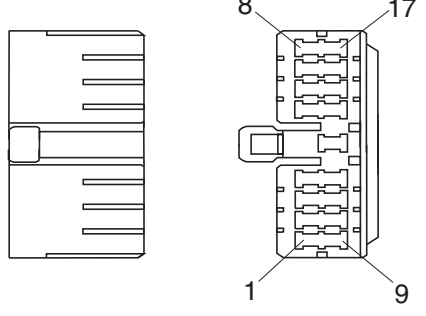
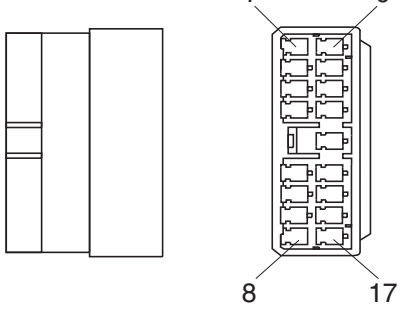
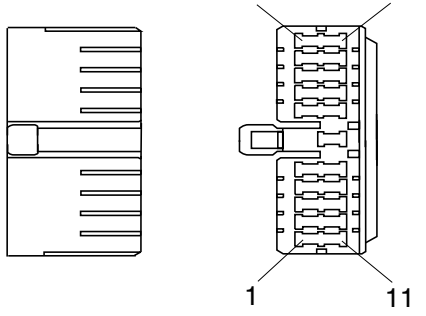
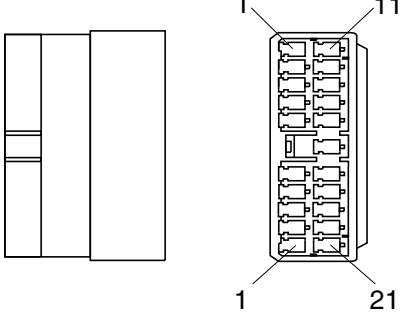
No. of pin	Receptacle connector (female)	Plug connector (male)
13	 <p style="text-align: center;">S811-013002</p>	 <p style="text-align: center;">S811-113002</p>
17	 <p style="text-align: center;">S811-017002</p>	 <p style="text-align: center;">S811-117002</p>
21	 <p style="text-align: center;">S811-021002</p>	 <p style="text-align: center;">S811-121002</p>

14) DEUTSCH DT CONNECTORS

DT 06 - 3S - ★★☆☆

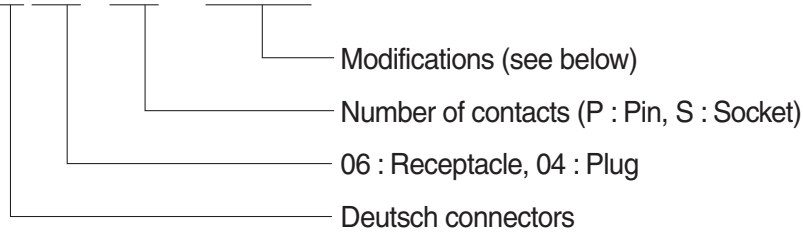

※ Modification

E003 : Standard end cap - gray

E004 : Color of connector to be black

E005 : Combination - E004 & E003

EP04 : End cap

EP06 : Combination P012 & EP04

P012 : Front seal enhancement - connectors color to black for 2, 3, 4 & 6pin

No. of pin	Receptacle connector (female)	Plug connector (male)
2	<p>DT06-2S</p>	<p>DT04-2P</p>
3	<p>DT06-3S</p>	<p>DT04-3P</p>
4	<p>DT06-4S</p>	<p>DT04-4P</p>

SYSTEM DIAGRAM

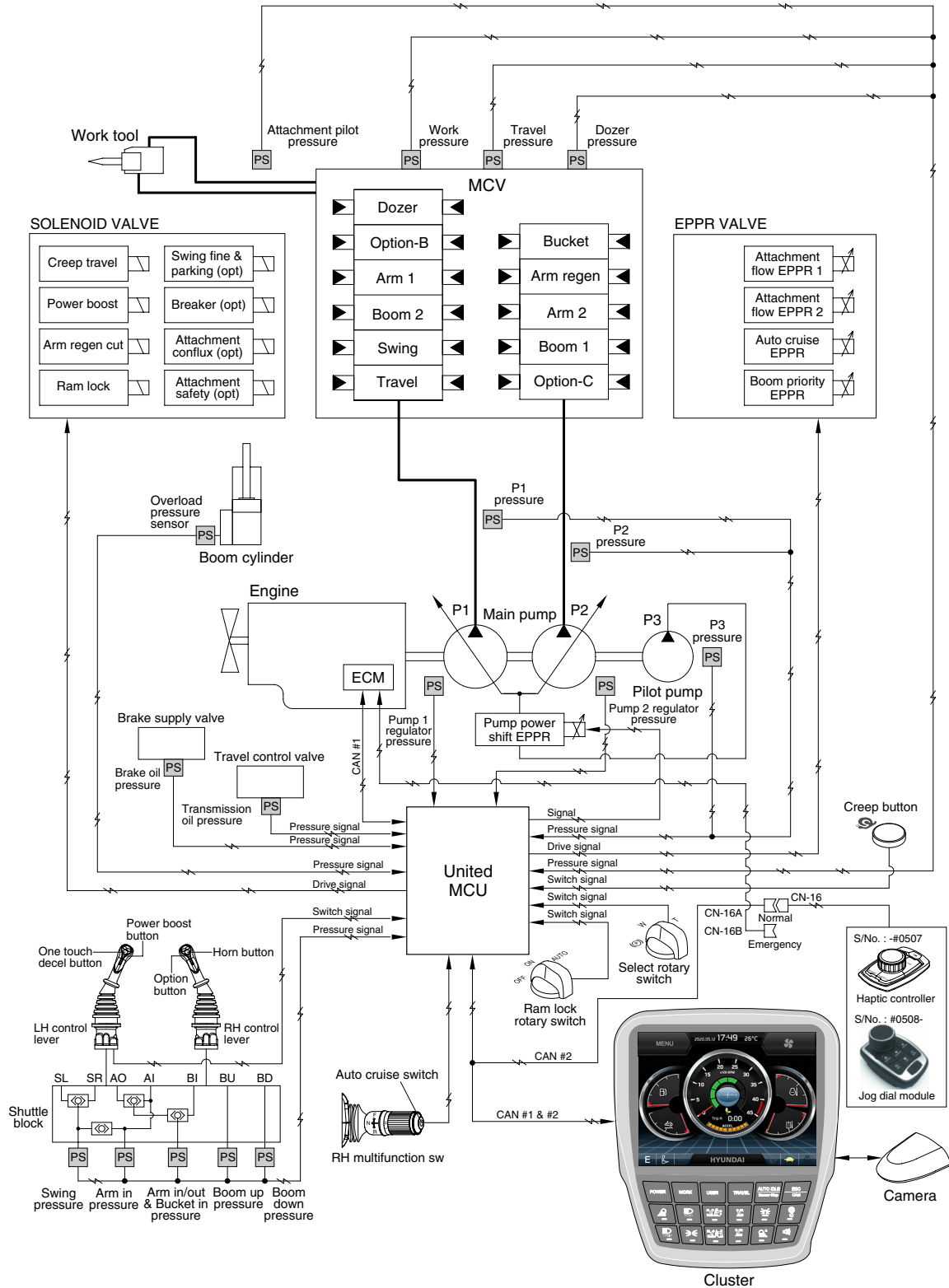

140WF5MS01A

GROUP 9 ATTACHMENT FLOW CONTROL SYSTEM

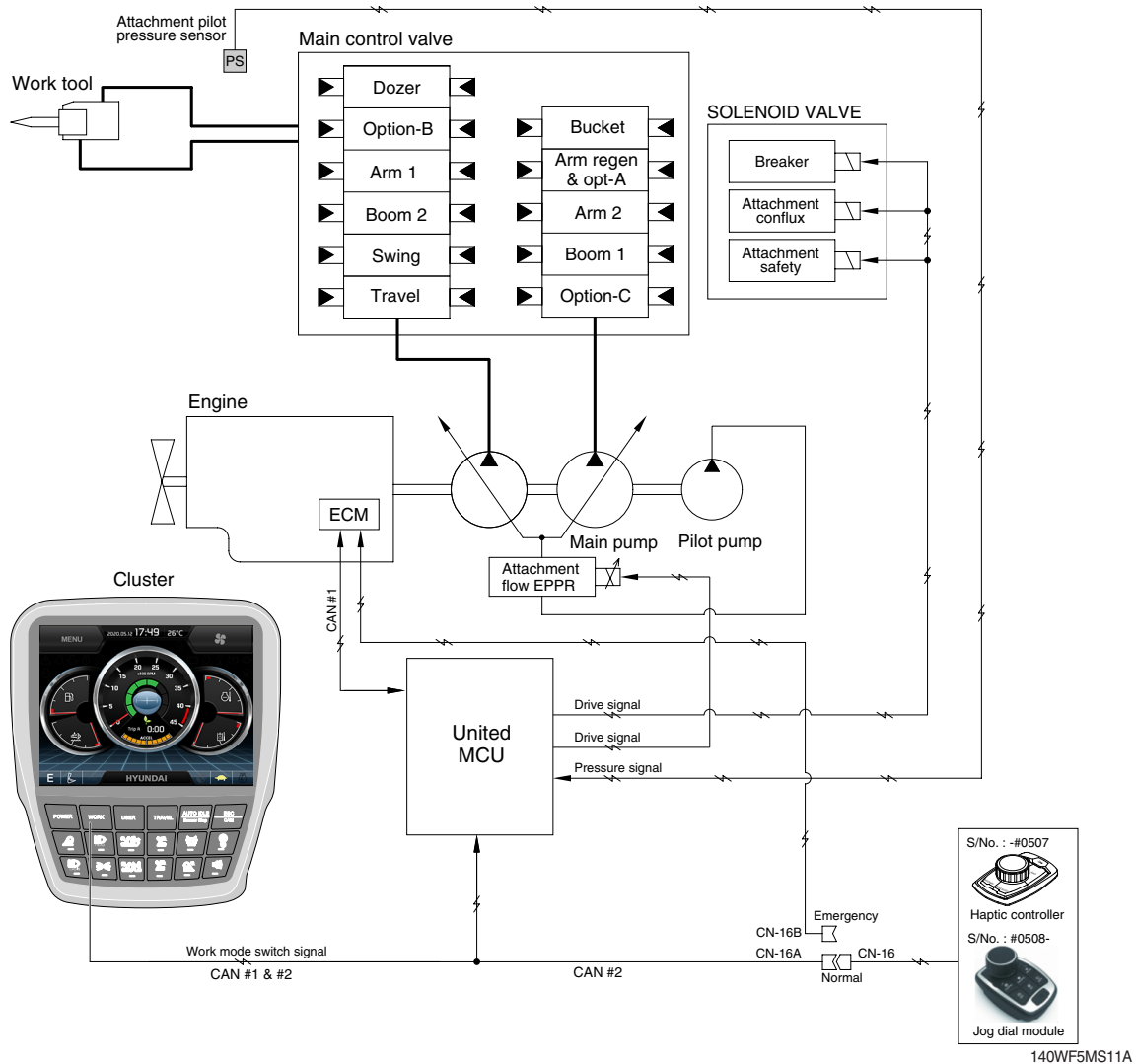

- The system is used to control the pump delivery flow according to set of the work tool on the cluster by the attachment flow EPPR valve.

Description	Work tool	
	Breaker	Crusher
Flow level	50~110 lpm	50~260 lpm
Attach safety solenoid	-	ON
Attach conflux solenoid	ON/OFF	ON/OFF
Breaker solenoid★	ON	-

※ Refer to the page 5-79 for the attachment kinds and max flow.

★ When breaker operating button is pushed.

(SERIAL NO. : #-0507)

DTC		Diagnostic Criteria	Application		
HCESPN	FMI		G	C	W
135	0	10 seconds continuous, Swing Pilot Press. Sensor Measurement Voltage > 5.2V	●		
	1	10 seconds continuous, 0.3V ≤ Swing Pilot Press. Sensor Measurement Voltage < 0.8V	●		
	4	10 seconds continuous, Swing Pilot Press. Sensor Measurement Voltage < 0.3V	●		
	(Results / Symptoms) 1. Monitor – Swing Pilot Press. display failure 2. Control Function – IPC operation, Boom first operation failure (Checking list) 1. CD-24 (#B) – CN-52 (#36) Checking Open/Short 2. CD-24 (#A) – CN-51 (#3) Checking Open/Short 3. CD-24 (#C) – CN-51 (#13) Checking Open/Short				
138	0	Monitor – Select Attachment(breaker / crusher) 10 seconds continuous, Attachment Pilot Press. Sensor Measurement Voltage > 5.2V	●		
	1	Monitor – Select Attachment(breaker / crusher) 10 seconds continuous, 0.3V ≤ Attachment Pilot Press. Sensor Measurement Voltage < 0.8V	●		
	4	Monitor – Select Attachment(breaker / crusher) 10 seconds continuous, Attachment Pilot Press. Sensor Measurement Voltage < 0.3V	●		
	(Results / Symptoms) 1. Monitor – Attachment Pilot Press. display failure 2. Control Function – Option attachment flow control operation failure (Checking list) 1. CD-69 (#B) – CN-53 (#14) Checking Open/Short 2. CD-69 (#A) – CN-53 (#3) Checking Open/Short 3. CD-69 (#C) – CN-53 (#13) Checking Open/Short				
139	1	10 seconds continuous, 0.3V ≤ Option Pilot Press. Sensor Measurement Voltage < 0.8V			●
	4	10 seconds continuous, Option Pilot Press. Sensor Measurement Voltage < 0.3V			●
	(Results / Symptoms) 1. Monitor – Option Pilot Press. display failure 2. Control Function – Auto Idle operation failure (Checking list) 1. CD-100 (#B) – CN-52 (#21) Checking Open/Short 2. CD-100 (#A) – CN-51 (#3) Checking Open/Short 3. CD-100 (#C) – CN-1 (#6) Checking Open/Short				

※ Some error codes are not applied to this machine.

G : General

C : Crawler Type

W : Wheel Type

(SERIAL NO. : #-0507)

DTC		Diagnostic Criteria	Application		
HCESPN	FMI		G	C	W
220	4	Mounting pressure sensor (HCESPN 128 or 205) (Detection) (When Boom Down Pilot Pressure Cutoff Solenoid is Off) 10 seconds continuous, Boom Down Pilot Pressure Cutoff Solenoid drive unit Measurement Voltage \leq 3.0V (Cancellation) (When Boom Down Pilot Pressure Cutoff Solenoid is Off) 3 seconds continuous, Boom Down Pilot Pressure Cutoff Solenoid drive unit Measurement Voltage $>$ 3.0V	●		
	6	(Detection) (When Boom Down Pilot Pressure Cutoff Solenoid is On) 10 seconds continuous, Boom Down Pilot Pressure Cutoff Solenoid drive current $>$ 6.5 A (Cancellation) (When Boom Down Pilot Pressure Cutoff Solenoid is On) 3 seconds continuous, Boom Down Pilot Pressure Cutoff Solenoid drive current \leq 6.5 A	●		
(Results / Symptoms) 1. Control Function – Boom floating control operation failure (Checking list) 1. CD-369 (#1) – CN-53 (#35) Checking Open/Short 2. CD-369 (#2) – CR-35 (#87) Checking Open/Short					
221	5	Monitor – Selecting attachment(breaker / crusher) (Detection) (When ATT Relief Setting EPPR 1 Current is equal or more than 10 mA) 10 seconds continuous, ATT Relief Setting EPPR 1 drive current = 0 mA (Cancellation) ATT Relief Setting EPPR 1 Current is equal or more than 10 mA) 3 seconds continuous, ATT Relief Setting EPPR 1 drive current \geq 10 mA	●		
	6	(Detection) 10 seconds continuous, ATT Relief Setting EPPR 1 drive current $>$ 1.0 A (Cancellation) 3 seconds continuous, ATT Relief Setting EPPR 1 drive current \leq 1.0 A	●		
(Results / Symptoms) 1. Control Function – Option attachment flow control – P1 relief pressure setting failure (Checking list) 1. CD-365 (#2) – CN-53 (#39) Checking Open/Short 2. CD-365 (#1) – CN-53 (#40) Checking Open/Short					

※ Some error codes are not applied to this machine.

G : General

C : Crawler Type

W : Wheel Type

(SERIAL NO. : #0508-)

DTC		Diagnostic Criteria	Application		
HCESPN	FMI		G	C	W
120	0	10 seconds continuous, Main Pump 1 (P1) Press. Sensor Measurement Voltage > 5.2V	●		
	1	10 seconds continuous, $0.3V \leq$ Main Pump 1 (P1) Press. Sensor Measurement Voltage < 0.8V	●		
	4	10 seconds continuous, Main Pump 1 (P1) Press. Sensor Measurement Voltage < 0.3V	●		
	(Results / Symptoms) 1. Monitor – Main Pump 1 (P1) Press. display failure 2. Control Function – Automatic voltage increase operation failure, Overload at compensation control failure (Checking list) 1. CD-42 (#B) – CN-52 (#22) Checking Open/Short 2. CD-42 (#A) – CN-51 (#32) Checking Open/Short 3. CD-42 (#C) – CN-51 (#31) Checking Open/Short				
121	0	10 seconds continuous, Main Pump 2 (P2) Press. Sensor Measurement Voltage > 5.2V	●		
	1	10 seconds continuous, $0.3V \leq$ Main Pump 2 (P2) Press. Sensor Measurement Voltage < 0.8V	●		
	4	10 seconds continuous, Main Pump 2 (P2) Press. Sensor Measurement Voltage < 0.3V	●		
	(Results / Symptoms) 1. Monitor – Main Pump 2 (P2) Press. display failure 2. Control Function – Automatic voltage increase operation failure, Overload at compensation control failure (Checking list) 1. CD-43 (#B) – CN-51 (#14) Checking Open/Short 2. CD-43 (#A) – CN-51 (#32) Checking Open/Short 3. CD-43 (#C) – CN-51 (#31) Checking Open/Short				
122	1	(when you had conditions mounting pressure sensor) 10 seconds continuous, $0.3V \leq$ Overload Press. Sensor Measurement Voltage < 0.8V	●		
	4	(when you had conditions mounting pressure sensor) 10 seconds continuous, Overload Press. Sensor Measurement Voltage < 0.3V	●		
	(Results / Symptoms) 1. Monitor – Overload Press. display failure 2. Control Function – Overload warning alarm failure (Checking list) 1. CD-31 (#B) – CN-52 (#28) Checking Open/Short 2. CD-31 (#A) – CN-51 (#32) Checking Open/Short 3. CD-31 (#C) – CN-51 (#31) Checking Open/Short				

※ Some error codes are not applied to this machine.

G : General

C : Crawler Type

W : Wheel Type

(SERIAL NO. : #0508-)

DTC		Diagnostic Criteria	Application		
HCESPN	FMI		G	C	W
181 (N.A)	4	(Model Parameter) mounting Reverse Cooling Fan Solenoid (Detection) (When Reverse Cooling Fan Solenoid is Off) 10 seconds continuous, Reverse Cooling Fan Solenoid drive unit Measurement Voltage \leq 3.0V (Cancellation) (When Reverse Cooling Fan Solenoid is Off) 3 seconds continuous, Reverse Cooling Fan Solenoid drive unit Measurement Voltage $>$ 3.0V	●		
	6	(Detection) (When Reverse Cooling Fan Solenoid is On) 10 seconds continuous, Reverse Cooling Fan Solenoid drive current $>$ 4.5 A (Cancellation) (When Reverse Cooling Fan Solenoid is On) 3 seconds continuous, Reverse Cooling Fan Solenoid drive current \leq 4.5 A	●		
(Results / Symptoms) 1. Control Function – Cooling Fan reverse control operation failure (not applicable)					
188	5	(Detection) (When Pump P1 regulator EPPR current is equal or more than 300 mA) 10 seconds continuous, Pump P1 regulator EPPR drive current $<$ 100 mA (Cancellation) (When Pump P1 regulator EPPR current is equal or more than 300 mA) 3 seconds continuous, Pump P1 regulator EPPR drive current \geq 100 mA	●		
	6	(Detection) 10 seconds continuous, Pump P1 regulator EPPR drive current $>$ 1.0 A (Cancellation) 3 seconds continuous, Pump P1 regulator EPPR drive current \leq 1.0 A	●		
(Results / Symptoms) 1. Control Function – IPC operation failure, Option attachment flow control operation failure (Checking list) 1. CN-242 (#2) – CN-54 (#27) Checking Open/Short 2. CN-242 (#1) – CN-54 (#02) Checking Open/Short					

※ Some error codes are not applied to this machine.

G : General

C : Crawler Type

W : Wheel Type

(SERIAL NO. : #0508-)

DTC		Diagnostic Criteria	Application		
HCESPN	FMI		G	C	W
841	2	10 seconds continuous, ECM Communication Data Error	●		
	(Results / Symptoms) 1. Control Function – ECM operation failure (Checking list) 1. CN-93 (#22) – CN-52 (#02) Checking Open/Short 2. CN-93 (#46) – CN-52 (#01) Checking Open/Short				
848	2	(When mounting the Jog Dial Module) 60 seconds continuous, Jog Dial Module Communication Data Error	●		
	(Results / Symptoms) 1. Control Function – Jog Dial Module operation failure (Checking list) 1. CN-8 (#2) – CN-51 (#09) Checking Open/Short 2. CN-8 (#3) – CN-51 (#08) Checking Open/Short				
850	2	(When mounting the RMCU) 60 seconds continuous, RMCU communication Data Error	●		
	(Results / Symptoms) 1. Control Function – RMCU operation failure (Checking list) 1. CN-125A (#3) – CN-51 (#09) Checking Open/Short 2. CN-125A (#11) – CN-51 (#08) Checking Open/Short				
866	2	(When mounting the AAVM) 60 seconds continuous, AAVM communication Data Error	●		
	(Results / Symptoms) 1. Control Function – AAVM operation failure (Checking list) 1. CN-401 (#86) – CN-51 (#09) Checking Open/Short 2. CN-401 (#87) – CN-51 (#08) Checking Open/Short				
867	2	60 seconds continuous, RDU communication Data Error	●		
	(Results / Symptoms) 1. Control Function – RDU operation failure (Checking list) 1. CN-376 (#10) – CN-51 (#09) Checking Open/Short 2. CN-376 (#18) – CN-51 (#08) Checking Open/Short				

※ Some error codes are not applied to this machine.

G : General

C : Crawler Type

W : Wheel Type

Fault code J1939 SPN J1939 FMI	Reason	Effect (only when fault code is active)
1239 2623 3	Accelerator pedal or lever position sensor 2 circuit - Voltage above normal or shorted to high source. High voltage detected at accelerator pedal position number 2 signal circuit.	The engine will operate in limp home mode.
1241 2623 4	Accelerator pedal or lever position sensor 2 circuit - Voltage below normal or shorted to low source. Low voltage detected at accelerator pedal position number 2 signal circuit.	The engine will operate in limp home mode.
1242 91 2	Accelerator pedal or lever position sensor 1 and 2 - Data erratic, intermittent, or incorrect. Accelerator position sensor number 1 and number 2 are reading different values.	The engine will only idle.
1515 91 19	Sae J1939 multiplexed accelerator pedal or lever sensor system - Received network data in error. The J1939 multiplexing controller has indicated a malfunction of the multiplexed accelerator pedal.	The engine will only idle.
1654 1323 31	Engine misfire cylinder 1- Condition exists. Engine misfire has been detected in cylinder number 1.	Possible reduced engine performance.
1655 1324 31	Engine misfire cylinder 2 - Condition exists. Engine misfire has been detected in cylinder number 2.	Possible reduced engine performance.
1656 1325 31	Engine misfire cylinder 3 - Condition exists. Engine misfire has been detected in cylinder number 3.	Possible reduced engine performance.
1657 1326 31	Engine misfire cylinder 4 - Condition exists. Engine misfire has been detected in cylinder number 4.	Possible reduced engine performance.
1658 1327 31	Engine misfire cylinder 5 - Condition exists. Engine misfire has been detected in cylinder number 5.	Possible reduced engine performance.
1659 1328 31	Engine misfire cylinder 6 - Condition exists. Engine misfire has been detected in cylinder number 6.	Possible reduced engine performance.
1668 1761 4	Aftertreatment diesel exhaust fluid tank level sensor circuit - Voltage below normal or shorted to low source. Low signal voltage detected at the aftertreatment diesel exhaust fluid tank level sensor circuit.	Possible reduced engine performance.
1669 1761 3	Aftertreatment diesel exhaust fluid tank level sensor circuit - Voltage above normal or shorted to high source. High signal voltage detected at the catalyst tank level sensor circuit.	Possible reduced engine performance.
1673 1761 1	Aftertreatment diesel exhaust fluid tank level - Data valid but below normal operating range - Most severe level. The aftertreatment diesel exhaust fluid tank level has fallen below the critical warning level.	Possible reduced engine performance.

※ Some fault codes are not applied to this machine.

Fault code J1939 SPN J1939 FMI	Reason	Effect (only when fault code is active)
3311 3242 0	Aftertreatment diesel particulate filter intake temperature - Data valid but above normal operating range - Most severe level. The aftertreatment diesel particulate filter intake temperature sensor reading has exceeded the maximum engine protection temperature limit.	Progressive power and/or speed derate increasing in severity from time of alert. If the engine protection shutdown feature is enabled, the engine will shut down 30 seconds after the red STOP lamps starts flashing.
3312 3246 0	Aftertreatment diesel particulate filter outlet temperature - Data valid but above normal operating range - Most severe level. The aftertreatment diesel particulate filter outlet temperature sensor reading has exceeded the maximum engine protection temperature limit.	Progressive power and/or speed derate increasing in severity from time of alert. If the engine protection shutdown feature is enabled, the engine will shut down 30 seconds after the red STOP lamps starts flashing.
3313 4765 4	Aftertreatment diesel oxidation catalyst intake temperature sensor circuit - Voltage below normal or shorted to low source. Low signal voltage detected at the catalyst intake sensor circuit.	Possible reduced engine performance.
3314 4765 3	Aftertreatment diesel oxidation catalyst intake temperature sensor circuit - Voltage above normal or shorted to high source. High signal voltage detected at the catalyst intake temperature sensor circuit.	Possible reduced engine performance.
3315 4765 2	Aftertreatment diesel oxidation catalyst intake temperature - Data erratic, intermittent, or incorrect. The aftertreatment diesel oxidation catalyst intake temperature sensor is not changing with engine operating conditions.	Possible reduced engine performance.
3316 3242 4	Aftertreatment diesel particulate filter intake temperature sensor circuit - Voltage below normal or shorted to low source. Low signal voltage detected at the aftertreatment diesel particulate filter intake temperature sensor circuit.	Possible reduced engine performance.
3317 3242 3	Aftertreatment diesel particulate filter intake temperature sensor circuit - Voltage above normal or shorted to high source. High signal voltage or open circuit detected at the aftertreatment diesel particulate filter intake temperature sensor circuit.	Possible reduced engine performance.
3318 3242 2	Aftertreatment diesel particulate filter intake temperature - Data erratic, intermittent, or incorrect. The aftertreatment diesel particulate filter intake temperature is not changing with engine operating conditions.	Possible reduced engine performance.
3319 3246 3	Aftertreatment diesel particulate filter outlet temperature sensor circuit - Voltage above normal or shorted to high source. High signal voltage or open circuit detected at the aftertreatment diesel particulate filter outlet temperature sensor circuit.	Possible reduced engine performance.

※ Some fault codes are not applied to this machine.

Fault code J1939 SPN J1939 FMI	Reason	Effect (only when fault code is active)
4245 5798 2	Aftertreatment diesel exhaust fluid dosing unit heater temperature - Data erratic, intermittent or incorrect. The aftertreatment diesel exhaust fluid dosing unit heater temperature is irrational.	None on performance.
4249 4337 10	Aftertreatment diesel exhaust fluid dosing temperature - Abnormal rate of change. The aftertreatment diesel exhaust fluid dosing unit temperature is stuck.	None on performance.
4251 5798 10	Aftertreatment 1 diesel exhaust fluid dosing unit heater temperature - Abnormal rate of change. The aftertreatment diesel exhaust fluid dosing unit heater temperature sensor reading is stuck.	None on performance.
4252 1081 31	Engine wait to start lamp - Condition exists. The received signal does not match the commanded signal.	None on performance.
4259 5742 11	Aftertreatment diesel particulate filter temperature sensor module - Root cause not known. Intermittent battery voltage supply detected at the aftertreatment diesel particulate filter temperature sensor module.	Possible reduced engine performance.
4261 5743 11	Aftertreatment selective catalytic reduction temperature sensor module - Root cause not known. Intermittent battery voltage supply detected at the aftertreatment SCR temperature sensor module.	Possible reduced engine performance.
4279 5848 21	Aftertreatment 1 SCR Intermediate NH3 - Data not rational - Drifted low. An in range low failure has been detected.	Possible reduced engine performance.
4281 5848 2	Aftertreatment SCR Intermediate NH3 - Data erratic, intermittent or incorrect. The aftertreatment SCR intermediate NH3 sensor reading is stuck.	None on performance.
4284 5793 9	Desired engine fueling state - Abnormal update rate. A valid message from the transmission ECU has NOT been received.	Engine may not start or may be difficult to start.
4289 91 8	Accelerator pedal or lever position sensor 1 circuit frequency - Abnormal frequency or pulse width or period. The accelerator pedal position sensor reading is out of range.	The engine will operate in limp home mode.
4452 520668 31	Aftertreatment outlet NOx sensor closed loop operation - Condition exists. The maximum dosing adjustment has been reached.	Possible reduced engine performance.
4453 520669 31	Aftertreatment intermediate NH3 sensor closed loop operation - Condition exists. The maximum dosing adjustment has been reached.	None on performance.
4517 237 13	Vehicle Identification number - Out of calibration. The vehicle identification number has not been programmed into the ECM.	None on performance.

※ Some fault codes are not applied to this machine.

2) EPPR VALVE CHECK PROCEDURE

(1) Check electric current value at EPPR valve

- ① Disconnect connector CN-133 from EPPR valve.
- ② Insert the adapter to CN-133 and install multimeter as figure.
- ③ Start engine.
- ④ Set S-mode and cancel auto decel mode.
- ⑤ If rpm display approx 1400 ± 50 rpm disconnect one wire harness from EPPR valve.
- ⑥ Check electric current in case of combined boom up and swing operation.

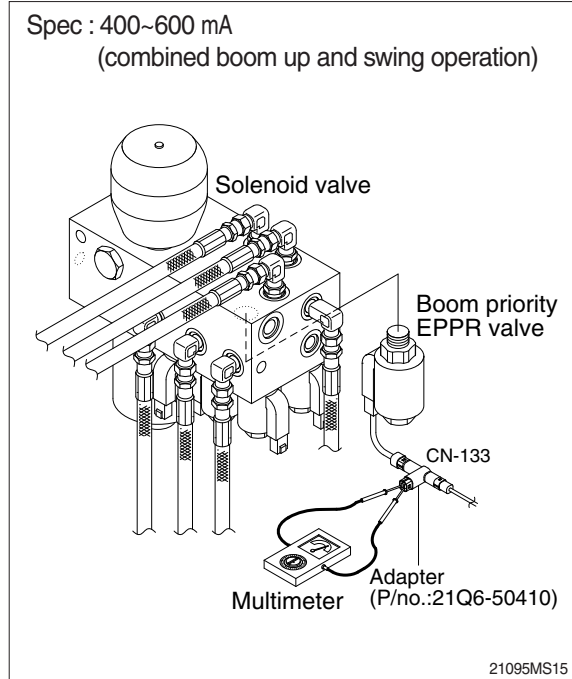

(2) Check pressure at EPPR valve

- ① Remove hose from A5 port and connect pressure gauge as figure.
 - Gauge capacity : 0 to 50 kgf/cm²
(0 to 725 psi)
- ② Start engine.
- ③ Set S-mode and cancel auto decel mode.
- ④ If rpm display approx 1400 ± 50 rpm check pressure (In case of combined boom up and swing operation).
- ⑤ If pressure is not correct, adjust it.
- ⑥ After adjust, test the machine.

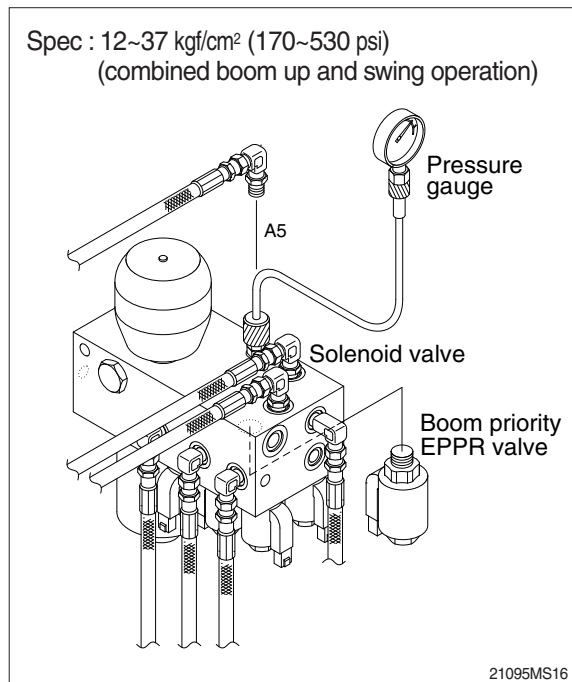

(5) Engine oil pressure warning lamp

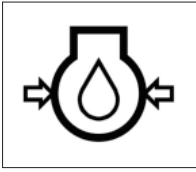

290F3CD65

- ① This warning lamp pops up and the buzzer sounds when the engine oil pressure is low.
- ② If the lamp blinks, shut OFF the engine immediately. Check oil level.

(6) Engine coolant low level warning lamp

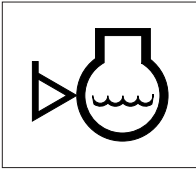

760F3CD58

- ① This warning lamp pops up and the buzzer sounds when the level of coolant is low.
- ② Fill the coolant immediately when the lamp is ON.

(7) Check engine warning lamp



290F3CD66

- ① This warning lamp pops up and the buzzer sounds when the communication between MCU and engine ECM on the engine is abnormal, or if the cluster received specific fault code from engine ECM.
- ② Check the communication line between them.
If the communication line is OK, then check the fault codes on the cluster.

(8) Engine stop warning lamp



※ Refer to page 5-72.

※ Refer to page 5-70.

※ Please contact your HD Hyundai Construction Equipment service center or local dealer.

(9) Battery charging warning lamp

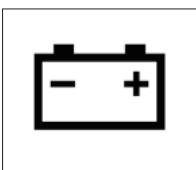

290F3CD67

- ① This warning lamp pops up and the buzzer sounds when the battery charging voltage is low.
- ② Check the battery charging circuit when this lamp blinks.

(3) User mode switch

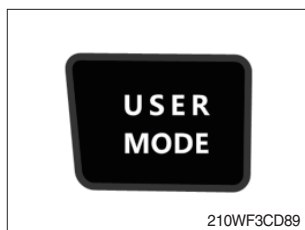

- ① This switch is used to select the user mode.
- ② Refer to page 5-82 for another set of the user mode.

(4) Auto idle/ buzzer stop switch



This switch is used to activate or cancel the auto idle function.

- Pilot lamp ON : Auto idle function is activated.
- Pilot lamp OFF : Auto idle function is cancelled.



The buzzer sounds when the machine has a problem.

In this case, push this switch and buzzer stops, but the warning lamp blinks until the problem is cleared.

(5) Travel mode switch



- ① This switch is used to select the travel speed alternatively.

-  : Low speed
-  : High speed

※ Do not change the setting of the travel mode switch.
Machine stability may be adversely affected.

⚠ Personal injury can result from sudden changes in machine stability.

(6) Escape/Camera switch



(7) Work lamp switch



This switch is used to operate the work lamp.

The pilot lamp is turned ON when operating the switch.

② Maintenance information

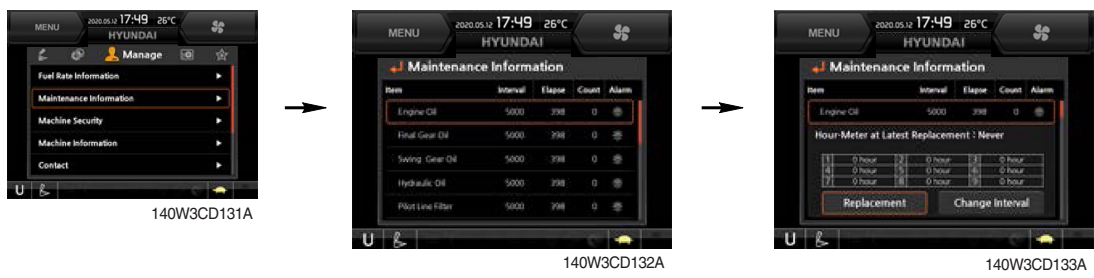

- Alarm lamp (●) is ON when oil or filter needs to be changed or replaced.
 - Replacement : The elapsed time will be reset to zero (0).
 - Change interval : The change or replace interval can be changed in the unit of 50 hours.
- ※ Refer to the maintenance chart for further information of maintenance interval.

(1) Power switch



- ① This switch makes the system ON/OFF.
Just before the power OFF, set values are stored.
- ② Default setting values

Function	Air conditioner	In/outlet	LCD	Temperature	Mode
Value	OFF	Inlet	OFF	Previous sw OFF	Previous sw OFF

(2) Air conditioner switch



- ① This switch turns the compressor ON/OFF.
- ※ **Air conditioner operates to remove vapor and drains water through a drain hose. Water can be sprayed into the cab in case that the drain cock at the ending point of drain hose has a problem.**
In this case, exchange the drain cock.

(3) Auto switch



- ① Auto air conditioner and heater system automatically keeps the optimum condition in accordance with operator's temperature configuration sensing ambient and cabin inside temperature.

(4) Setting temperature



- ① Display the temperature setting out.

(5) Temperature switch

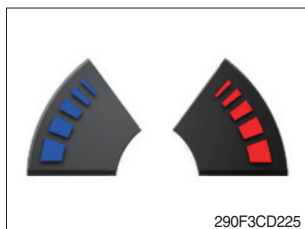

- ① Setting temperature indication
 - Lo (17°C), 17.5~31.5°C, Hi (32°C)
- ② Max cool and max warm beeps 5 times.
- ③ The max cool or the max warm position operates as following table.

Temperature	Compressor	Fan speed	In/outlet	Mode
Max cool	ON	Hi (8 step)	Recirculation	Face
Max warm	OFF	Hi (7 step)	Fresh	Def/Foot

- ④ Temperature unit can be changed between celsius (°C) and fahrenheit (°F)
 - a. Default status (°C)
 - b. Push Up/Down temperature switch simultaneously more than 5 second displayed temperature unit change (°C → °F)

2. DRIVE SYSTEM

1) UNUSUAL NOISE COMES OUT OF PUMP CONNECTION

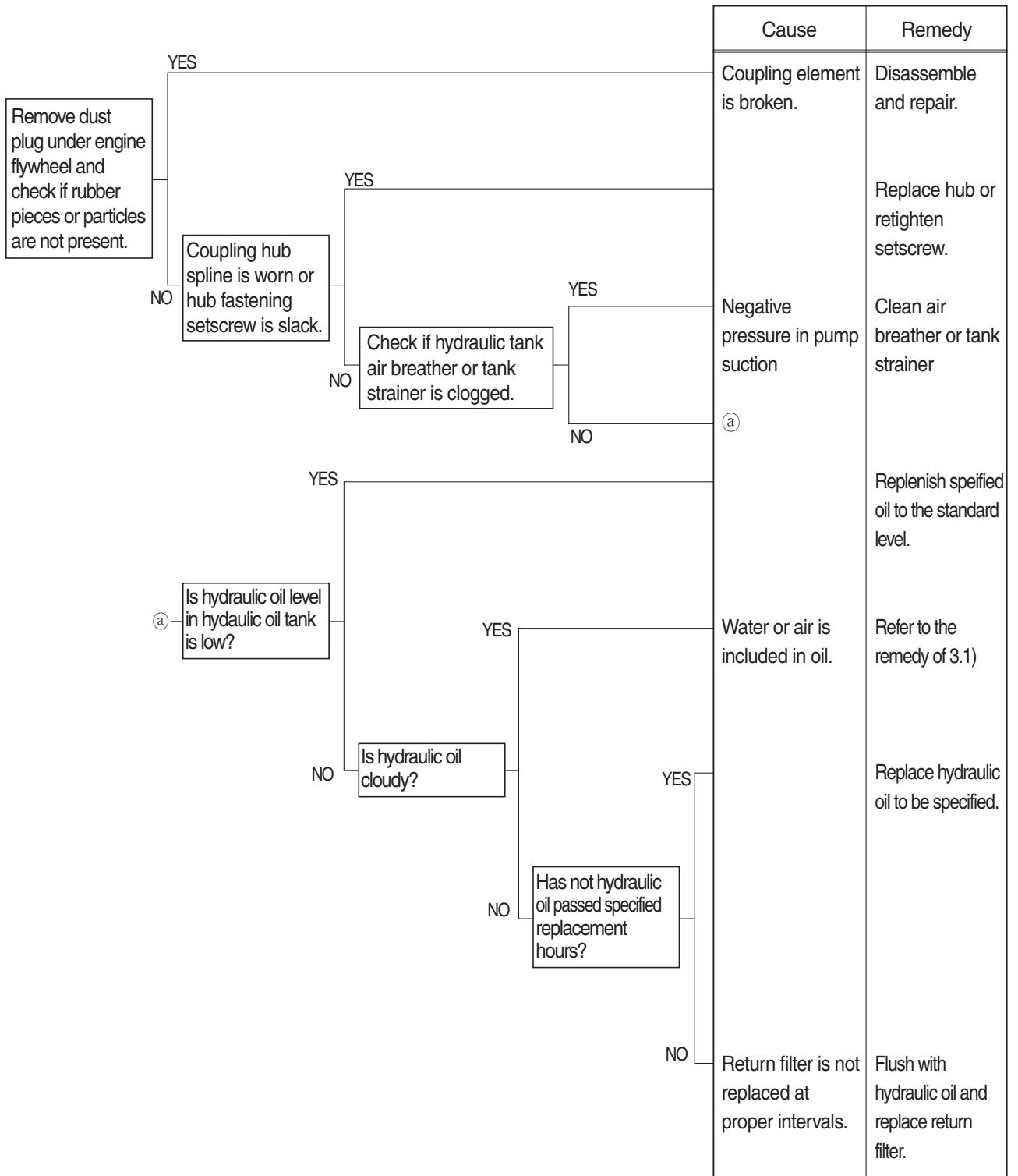

2) TRAVEL ACTION IS POWERLESS (travel only)

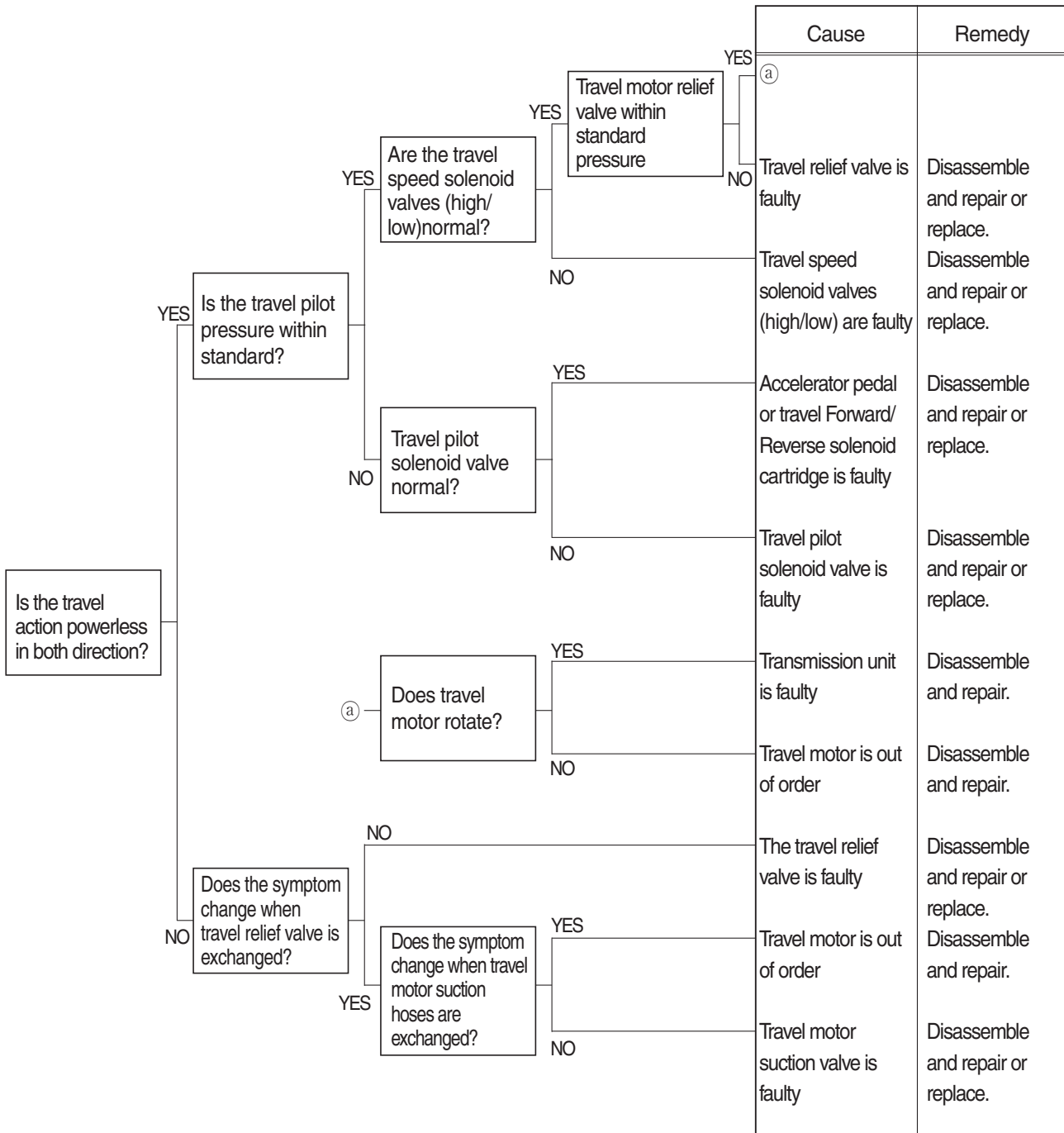

Problem	Cause	Correction
Oil coming out of breather	21. Leak in internal brake system 22. Leak in diff-lock actuating cylinder	See correction No.2 and No.3. See correction No.19.
Nospin indexing noise when driving straight ※ With nospin, fatigue damage can occur on the side with the larger tire.	23. Unequal tire pressure left and right 24. Different style, size or brand of tires between left and right hand side	Inflate tires to the recommended pressure in this manual, or until the rolling radius is equal. Change tires to make the rolling radius equal. Vary the tire pressure within the specifications until the rolling radius is equal.
Noise during coast and under power the same	25. Wheel bearings damaged	Replace and adjust
Noise under power greater than during coast	26. Low oil level 27. Incorrect lubricant 28. Ring and pinion worn 29. Worn ring and pinion bearings 30. Worn planetary gears or bearings	Refill oil to proper level See correction No.16. Inspect through top cover. Replace and adjust. Replace and adjust Replace.
Noise during coast greater than under power	31. Loose pinion nut 32. Only pinion bearing damaged	Inspect ring, pinion and pinion bearings. If undamaged, retighten nut. See correction No.29.
Noise during turn (Without nospin)	33. Worn spider and/or side gears	Replace.
A stick slip noise when going from forward to reverse	34. Worn or damaged cardan shaft 35. Loose wheel 36. Articulation box joint and achsel shaft damaged 37. Spider pins loose in diff-carrier 38. Damaged or missing spider and/or side gear washers	Inspect and replace. Inspect for wheel and wheel stud damage. Replace if needed and retorque lugnuts. Inspect and replace. Inspect through top cover. Replace. See correction No.33.

10. WHEN SAFETY SOLENOID DOES NOT OPERATE\ (SERIAL NO. : -#0507)

- Before disconnecting the connector, always turn the starting switch OFF.
- Before carrying out below procedure, check all the related connectors are properly inserted and short of fuse No. 28.
- After checking, insert the disconnected connectors again immediately unless otherwise specified.

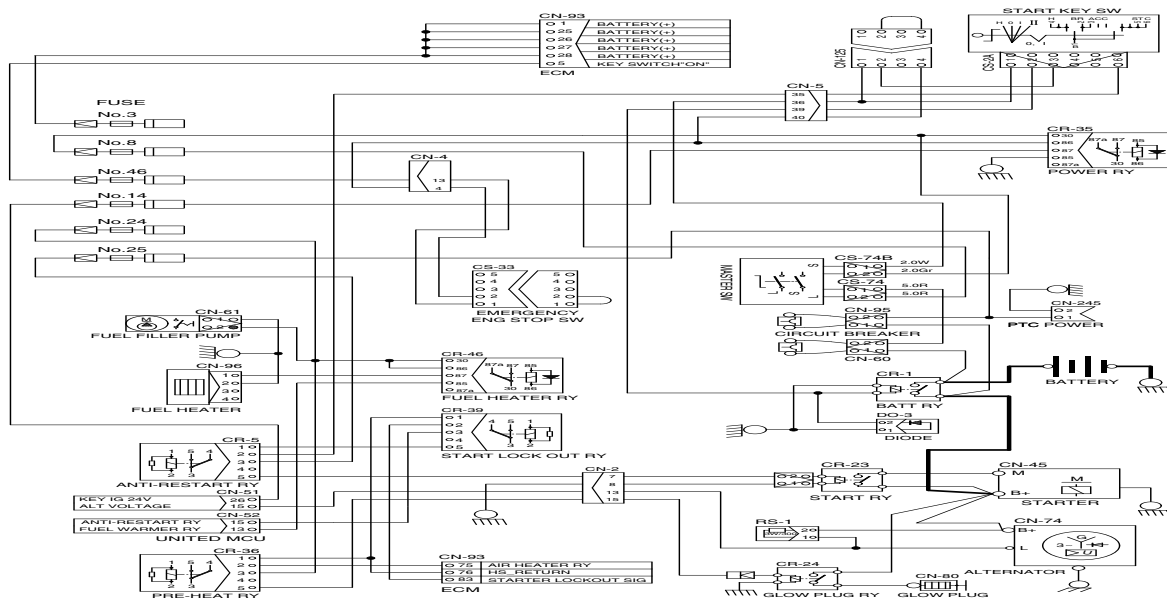
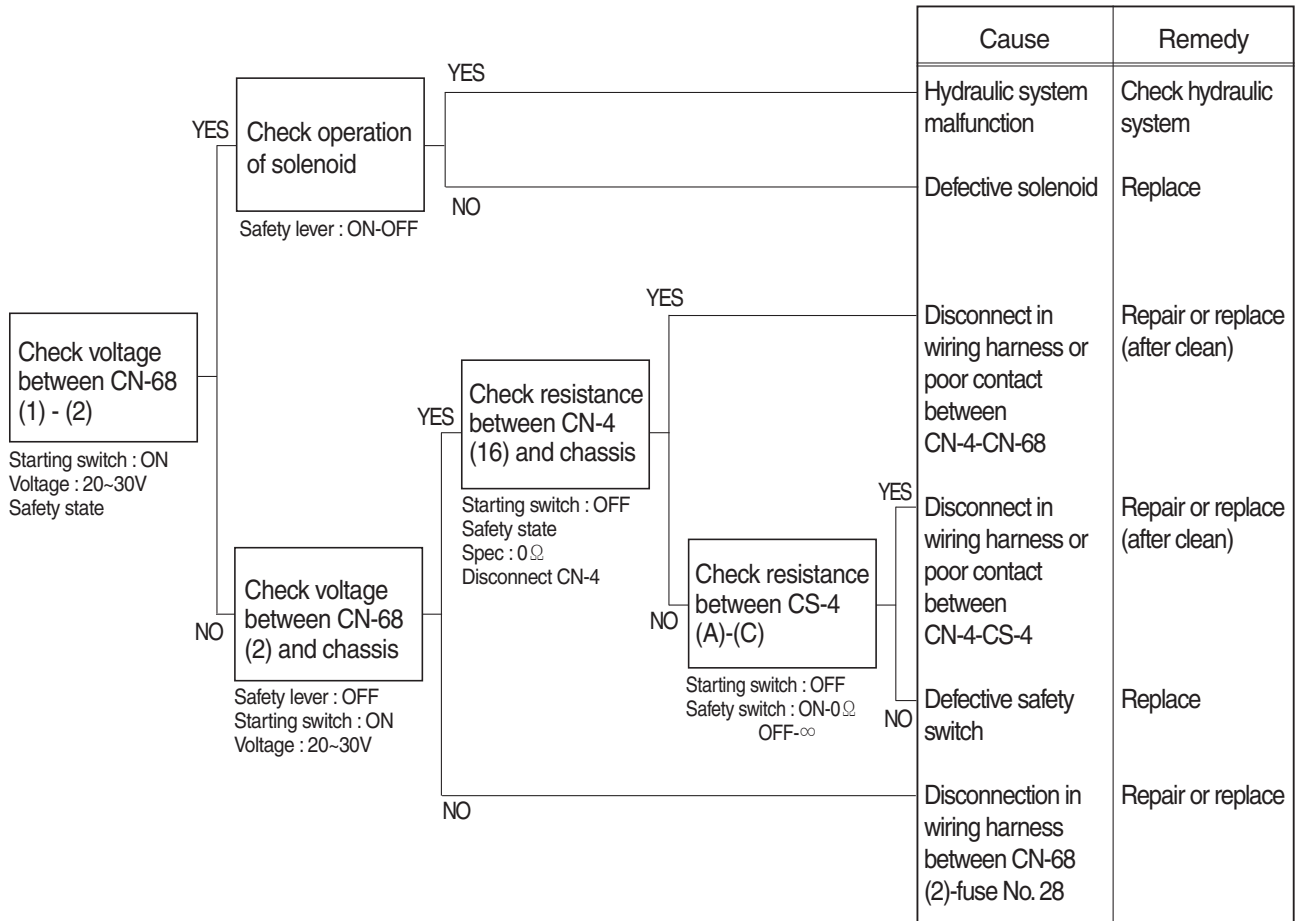

140WF6ES12

4.  **WHEN COOLANT OVERHEAT WARNING LAMP LIGHTS UP** (engine is started)
(SERIAL NO. : #0508-)

- Before disconnecting the connector, always turn the starting switch OFF.
- Before carrying out below procedure, check all the related connectors are properly inserted.
- After checking, insert the disconnected connectors again immediately unless otherwise specified.

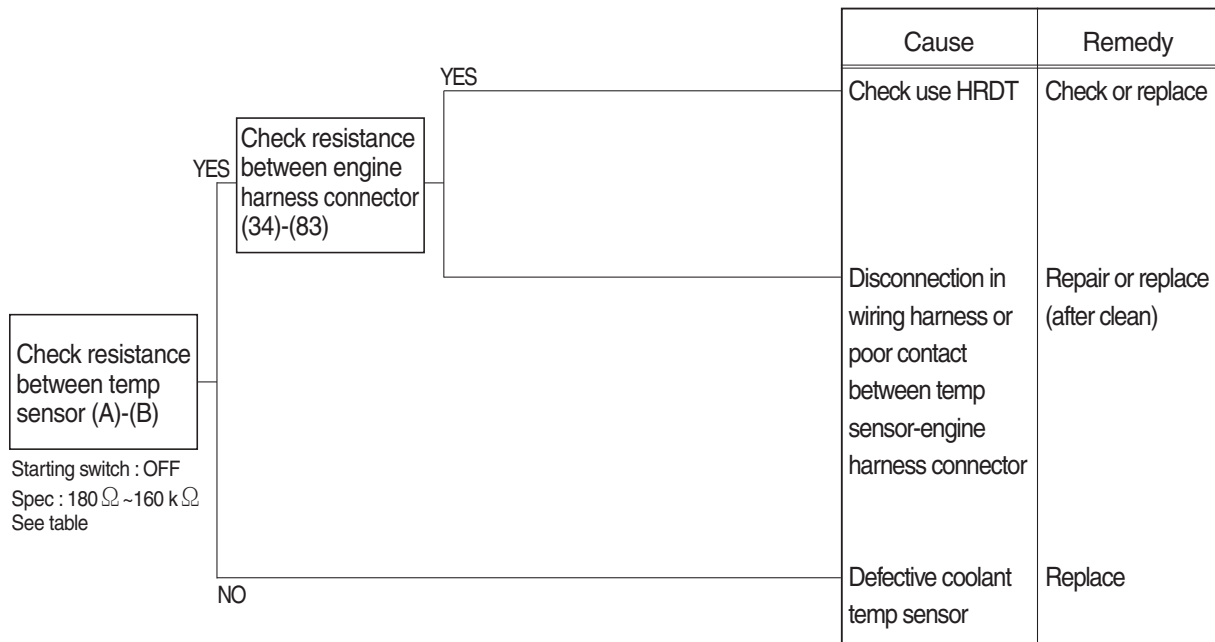

Check Table

Temperature (°C)					
Resistance (kΩ)					

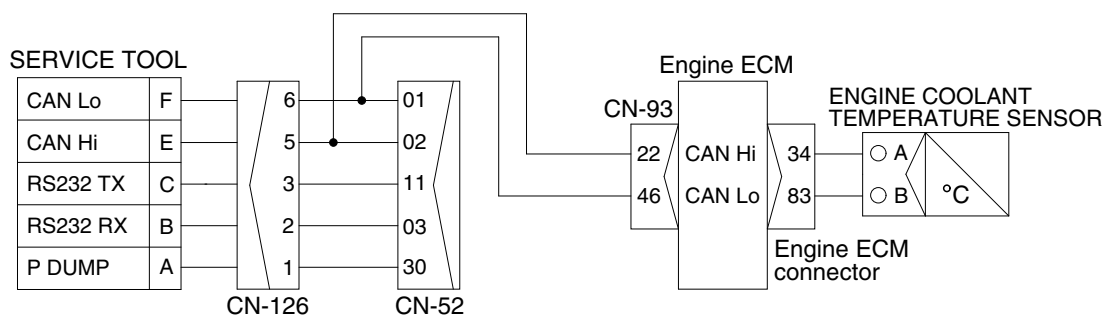

300L6ES104

14. WHEN STARTING SWITCH IS TURNED ON, WIPER MOTOR DOES NOT OPERATE

(SERIAL NO. : #0508-)

- Before disconnecting the connector, always turn the starting switch OFF.
- Before carrying out below procedure, check all the related connectors are properly inserted and the fuse No. 10, 23 and 39 is not blown out.
- After checking, insert the disconnected connectors again immediately unless otherwise specified.

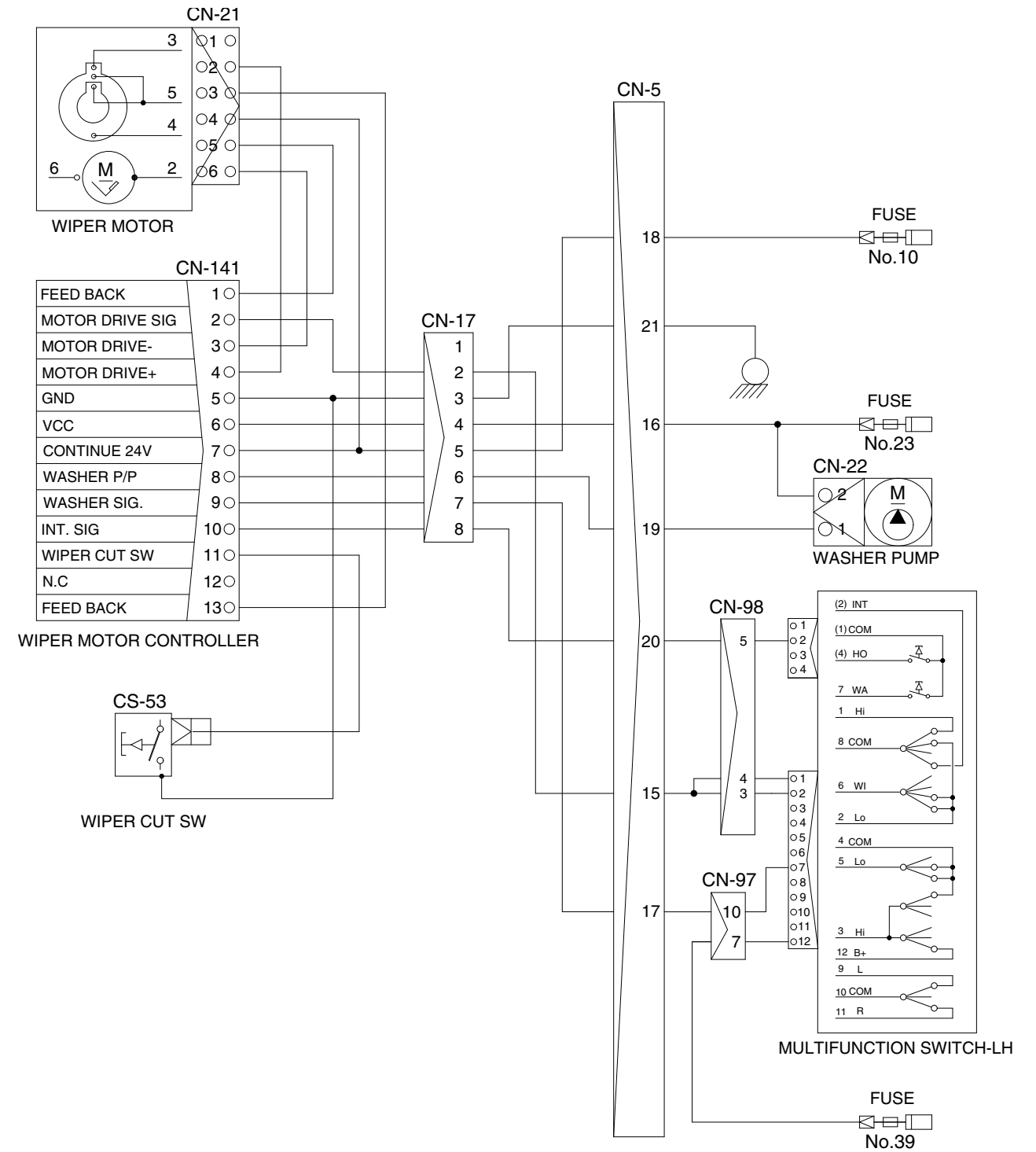
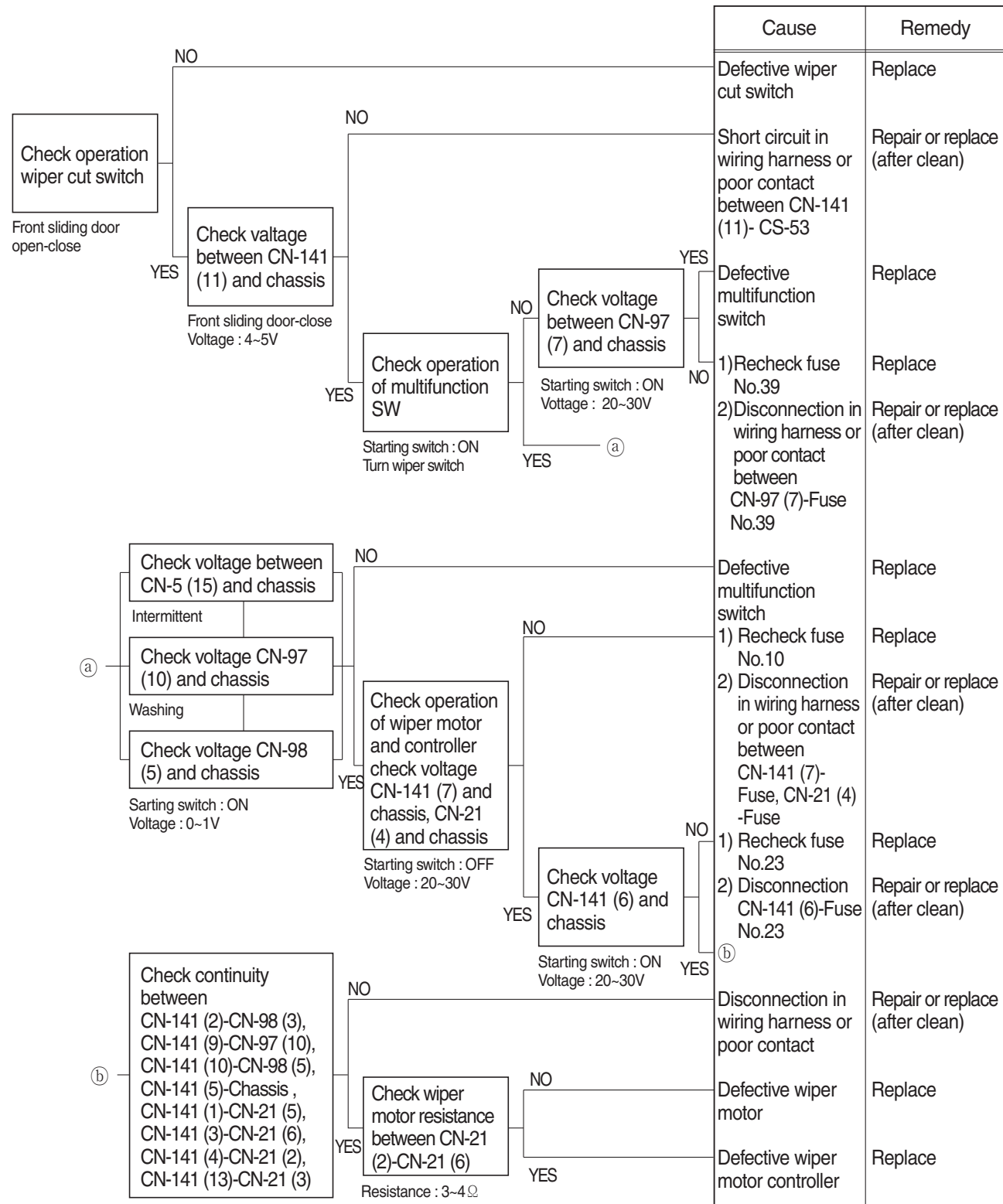

5. MALFUNCTION OF PUMP 1 PRESSURE SENSOR (SERIAL NO. : -#0507)

· Fault code : HCESPN 120, FMI 0~4

※ Before carrying out below procedure, check all the related connectors are properly inserted.

1) INSPECTION PROCEDURE

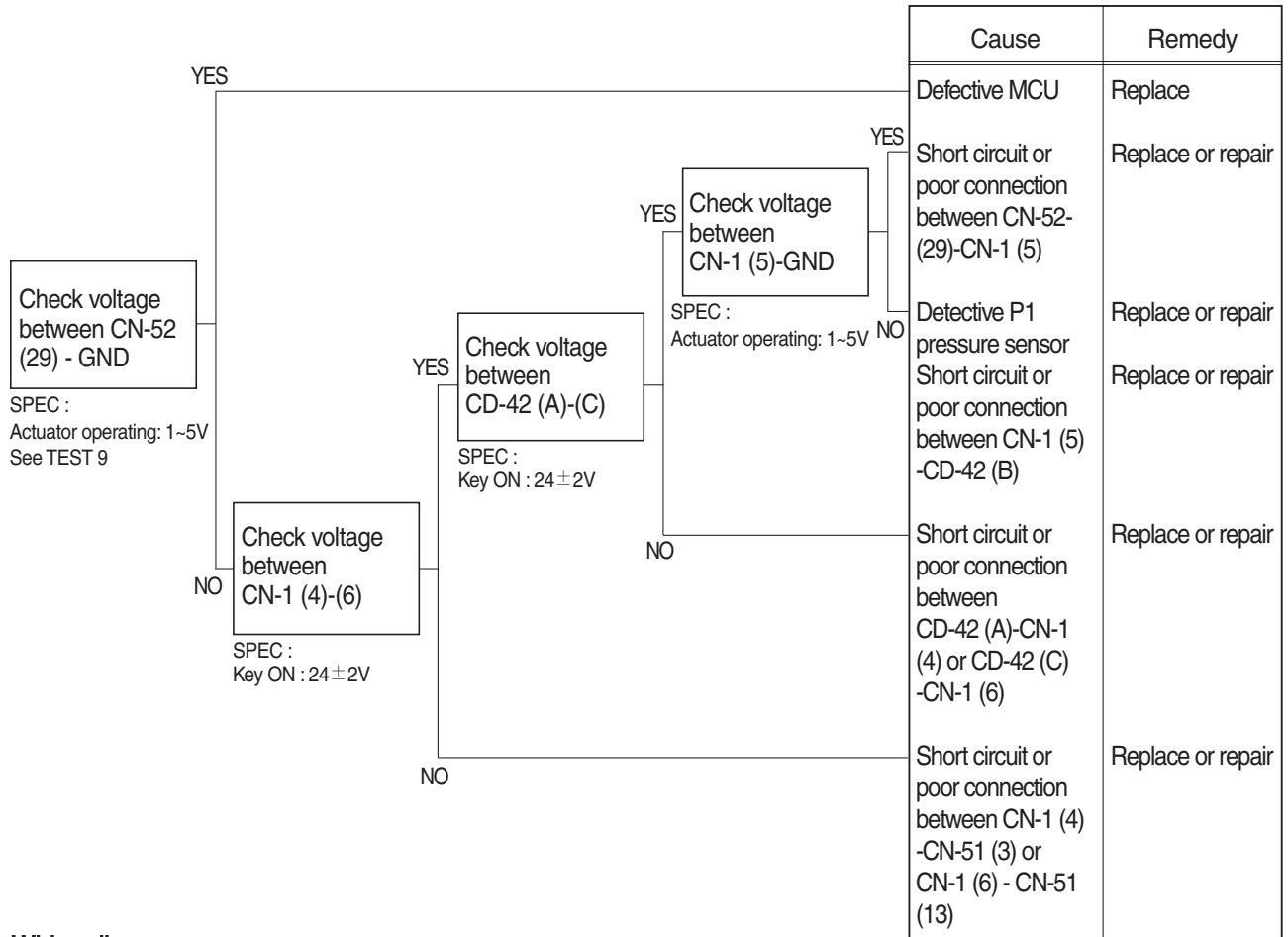

Wiring diagram

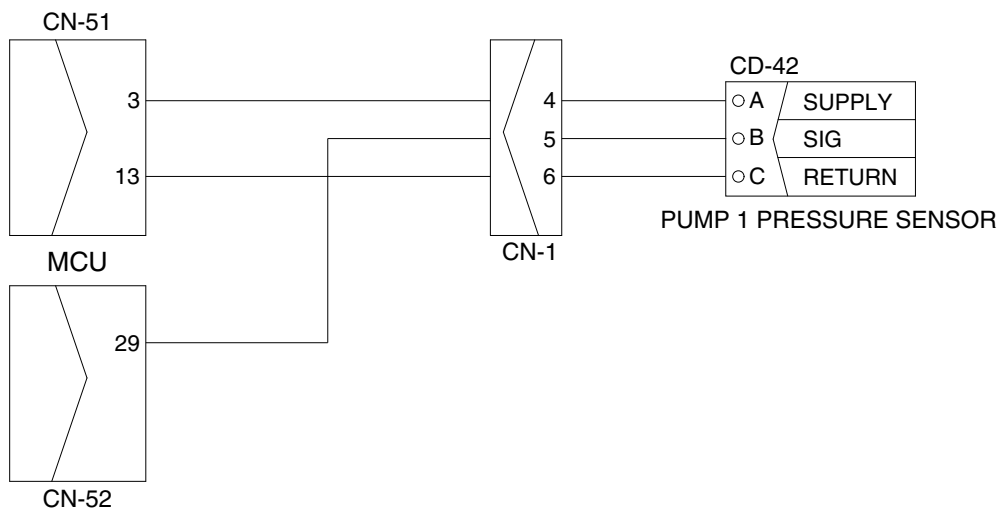

CLICK HERE TO **DOWNLOAD** THE COMPLETE MANUAL

- Thank you very much for reading the preview of the manual.
- You can download the complete manual from: www.heydownloads.com by clicking the link below



- Please note: If there is no response to CLICKING the link, please download this PDF first and then click on it.

CLICK HERE TO **DOWNLOAD** THE COMPLETE MANUAL

10. MALFUNCTION OF SWING PRESSURE SENSOR (SERIAL NO. : -#0507)

· Fault code : HCESPN 135, FMI 0~4

※ Before carrying out below procedure, check all the related connectors are properly inserted.

1) INSPECTION PROCEDURE

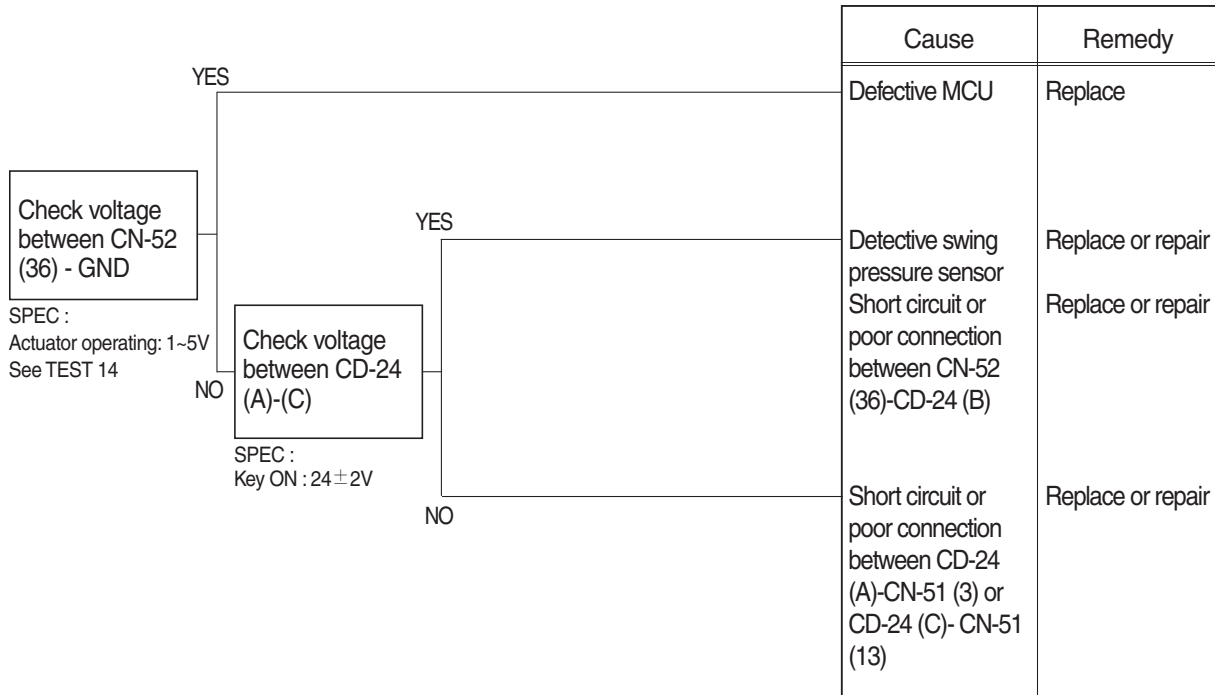

Wiring diagram

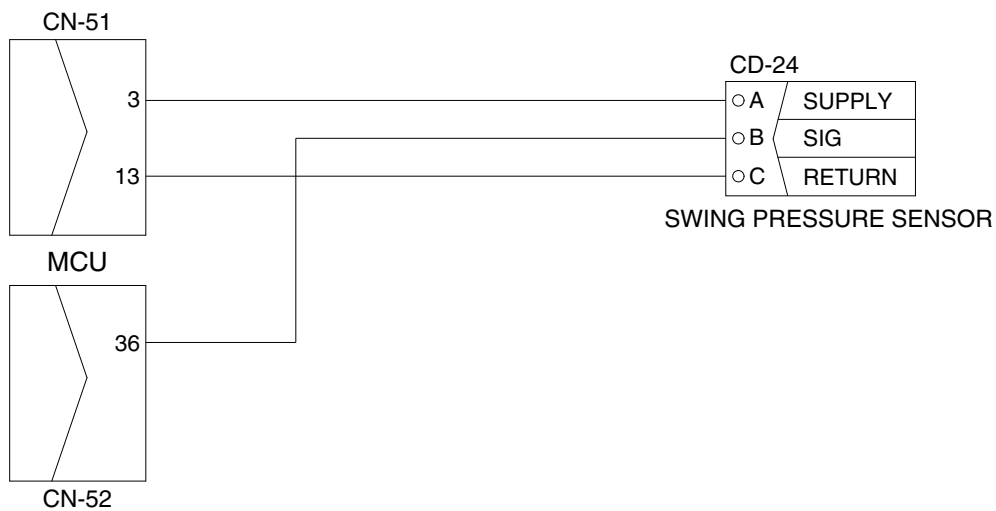

300L6MS15

15. MALFUNCTION OF BOOM PRIORITY EPPR VALVE (SERIAL NO. : -#0507)

· Fault code : HCESPN 141, FMI 5 or 6

※ Before carrying out below procedure, check all the related connectors are properly inserted.

1) INSPECTION PROCEDURE

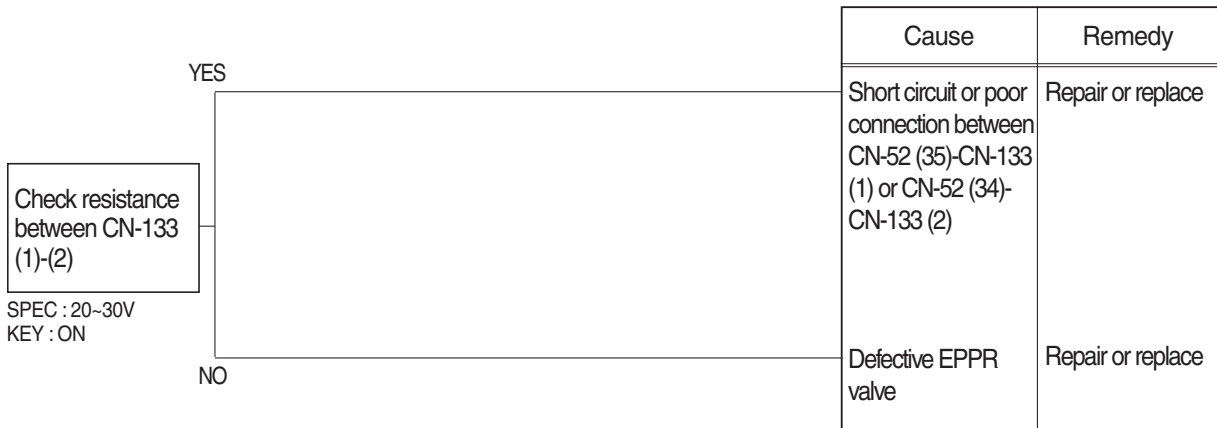

Wiring diagram

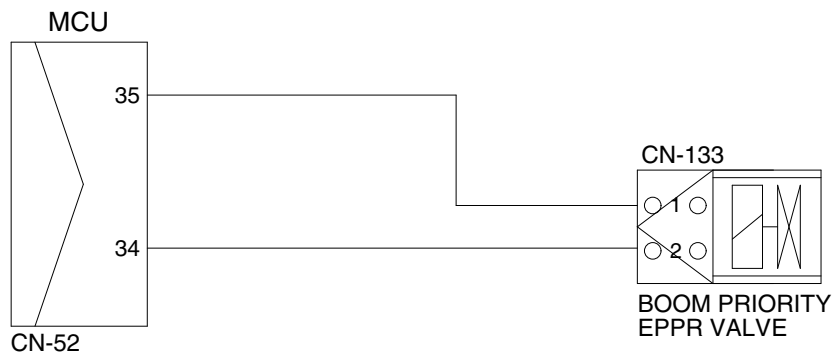

300L6MS23

(SERIAL NO. : -#0507)

2) TEST PROCEDURE

(1) **Test 24** : Check voltage at CN-54 (23) and ground.

- ① Prepare 1 piece of thin sharp pin, steel or copper.
- ② Insert prepared pin to rear side of connectors : One pin to (23) of CN-54.
- ③ Starting key ON.
- ④ Check voltage as figure.

SPEC : Actuator operating : 1~5 V

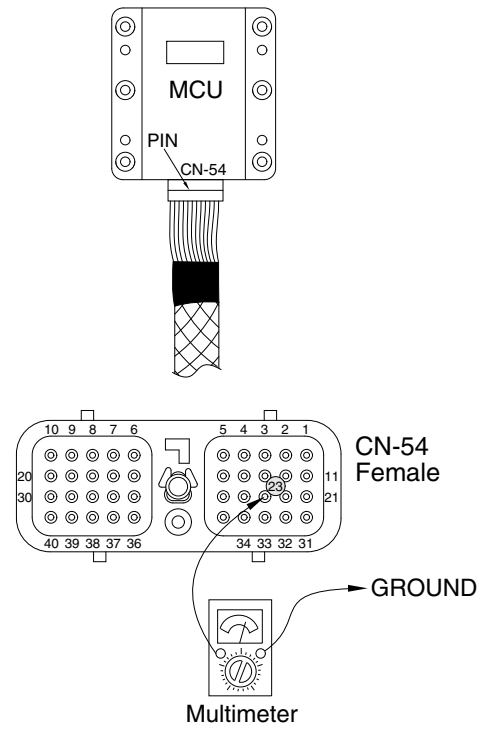

210WF6MS16A

5. MALFUNCTION OF PUMP 1 PRESSURE SENSOR (SERIAL NO. : #0508-)

· Fault code : HCESPN 120, FMI 0~4

※ Before carrying out below procedure, check all the related connectors are properly inserted.

1) INSPECTION PROCEDURE

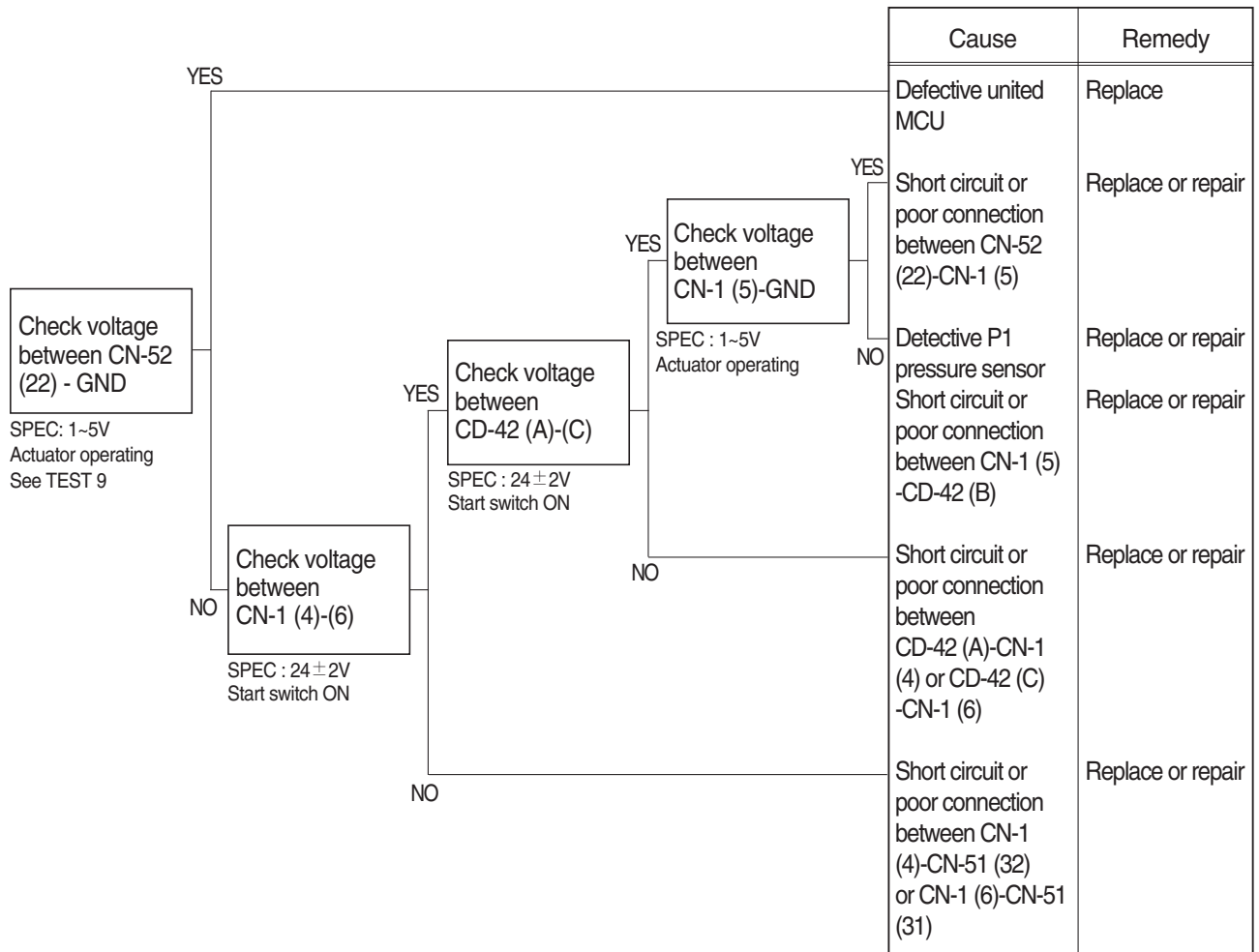

Wiring diagram

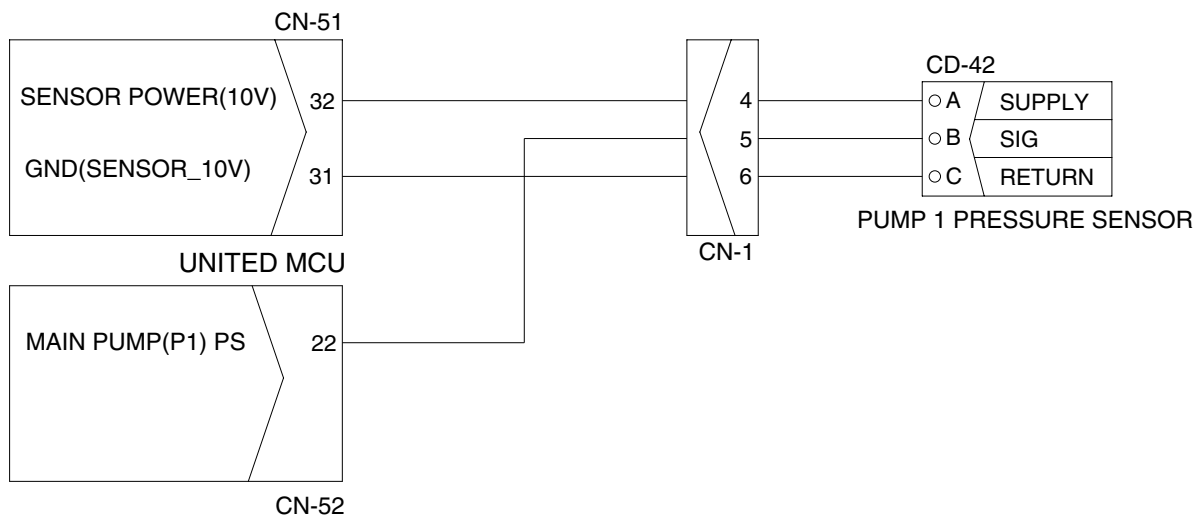

140WF6MS105

10. MALFUNCTION OF SWING PRESSURE SENSOR (SERIAL NO. : #0508-)

· Fault code : HCESPN 135, FMI 0~4

※ Before carrying out below procedure, check all the related connectors are properly inserted.

1) INSPECTION PROCEDURE

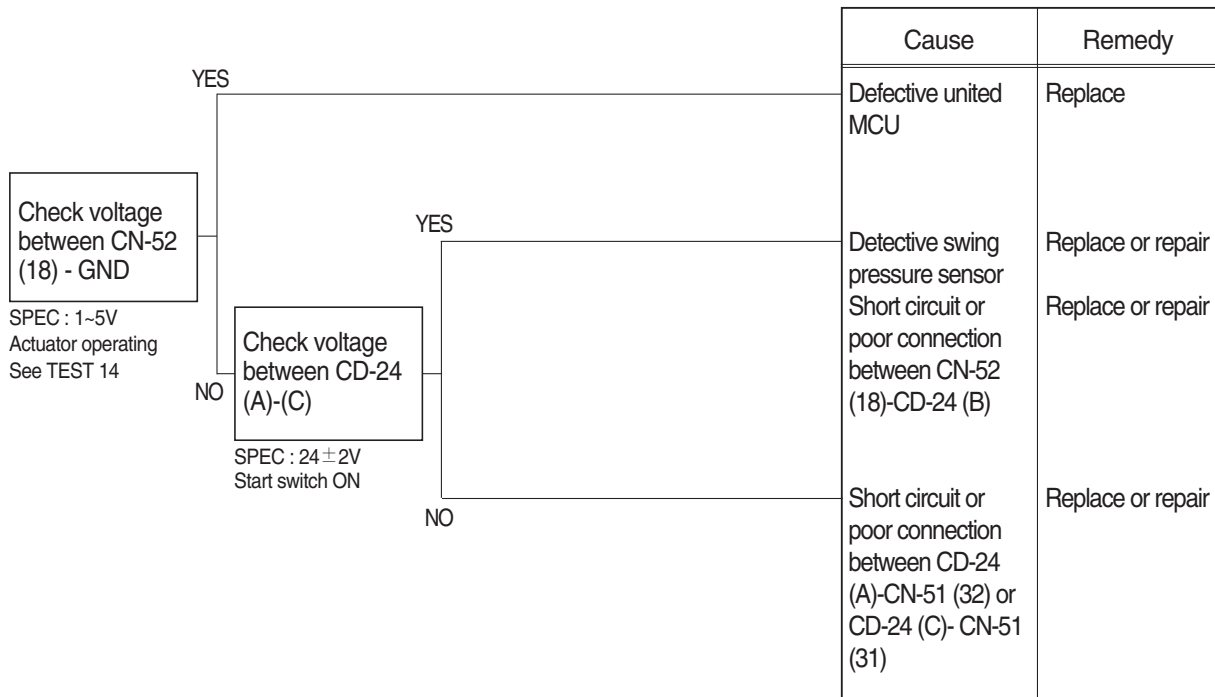

Wiring diagram

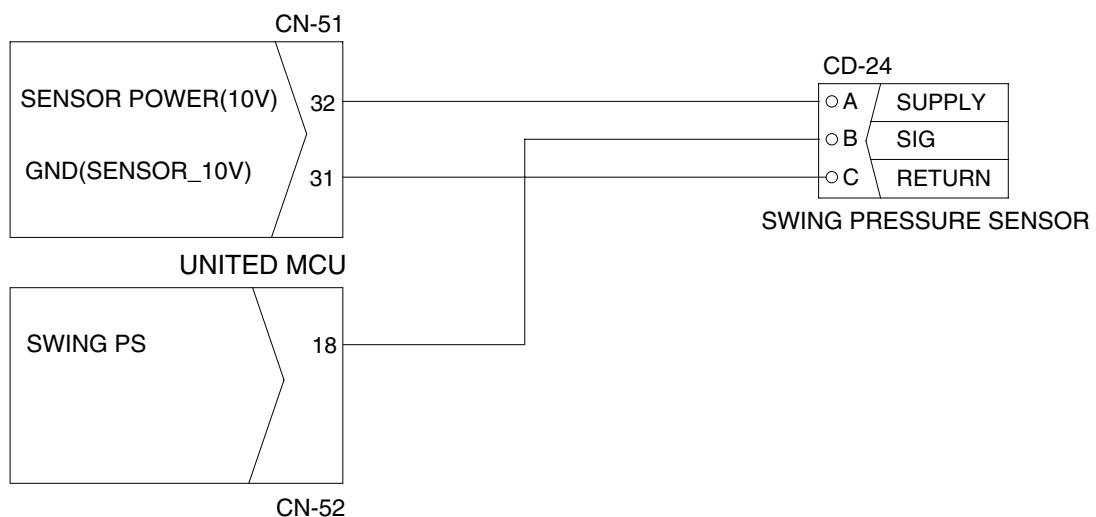

140WF6MS115

15. MALFUNCTION OF BOOM PRIORITY EPPR VALVE (SERIAL NO. : #0508-)

· Fault code : HCESPN 141, FMI 5 or 6

※ Before carrying out below procedure, check all the related connectors are properly inserted.

1) INSPECTION PROCEDURE

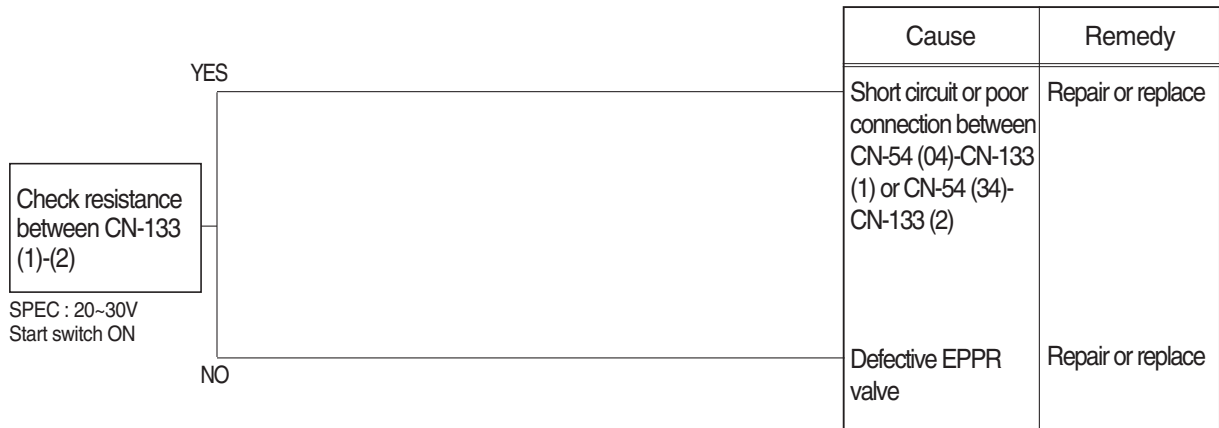

Wiring diagram

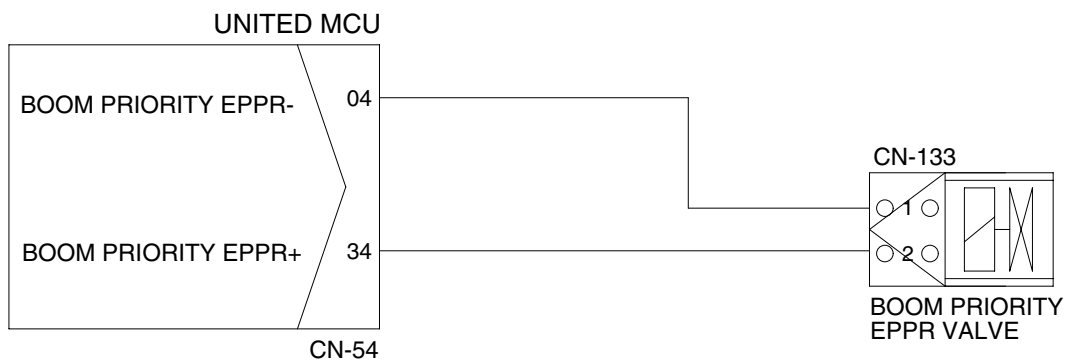

140WF6MS123

(SERIAL NO. : #0508-)

2) TEST PROCEDURE

(1) **Test 24** : Check voltage at CN-52 (20) and ground.

- ① Prepare 1 piece of thin sharp pin, steel or copper.
- ② Insert prepared pin to rear side of connectors : One pin to (20) of CN-52.
- ③ Starting switch ON.
- ④ Check voltage as figure.

SPEC : Actuator operating : 1~5 V

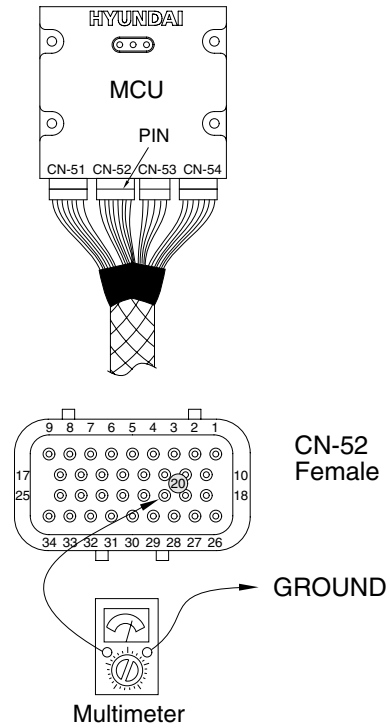

140WF6MS167

2) ENGINE SPEED

(1) Measure the engine speed at each power mode

※ The engine speed at each power mode must meet standard RPM; if not, all other operational performance data will be unreliable. It is essential to perform this test first.

(2) Preparation

- ① Warm up the machine, until the engine coolant temperature reaches 50°C or more, and the hydraulic oil is 50±5°C.
- ② Set the accel dial at 10 (Max) position.
- ③ Measure the engine RPM.

(3) Measurement

- ① Start the engine. The engine will run at start idle speed. Measure engine speed with a engine rpm display.
- ② Measure and record the engine speed at each mode (P, S, E).
- ③ Select the P-mode.
- ④ Lightly operate the bucket control lever a few times, then return the control lever to neutral; The engine will automatically enter the auto-idle speed after 4 seconds.
- ⑤ Measure and record the auto deceleration speed.

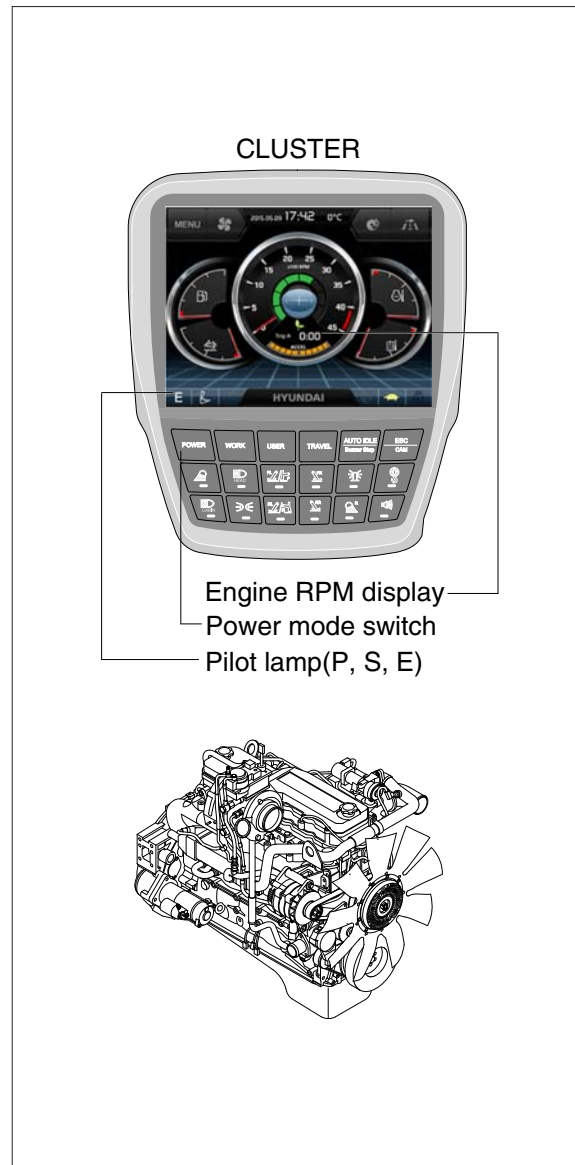

(4) Evaluation

The measured speeds should meet the following specifications.

Unit : rpm

Model	Engine speed	Standard	Remarks
HW140	Start idle	800±100	
	P mode	1500±50	
	S mode	1400±50	
	E mode	1300±50	
	Auto decel	1000±100	
	One touch decel	800±50	

11) PILOT PRIMARY PRESSURE

(1) Preparation

- ① Keep the hydraulic oil temperature at $50 \pm 5^\circ\text{C}$.

(2) Measurement

- ① Select the following switch positions.
 - Power mode switch : P mode
 - Auto decel switch : OFF
- ② Measure the primary pilot pressure by the monitoring menu of the cluster.

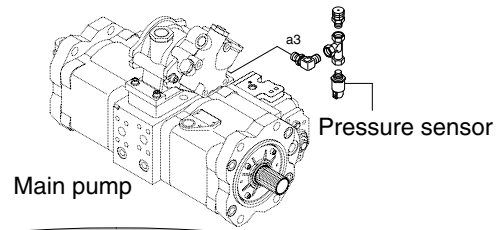

Monitoring (analog)

(3) Evaluation

The average measured pressure should meet the following specifications:

Unit : kgf / cm^2

Model	Kind of lever	Standard	Maximum allowable	Remarks
HW140	M mode	$40 \begin{smallmatrix} +2 \\ 0 \end{smallmatrix}$	-	

140WF7MS12

5. RCV LEVER

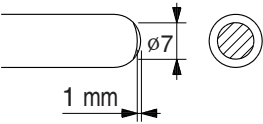
Maintenance check item	Criteria	Remark
Leakage	The valve is to be replaced when the leakage becomes more than 1000 cc/m at neutral handle position, or more than 2000 cc/m during operation.	Conditions : Primary pressure : 40 kgf/cm ² Oil viscosity : 23 cSt
Spool	This is to be replaced when the sliding surface has worn more than 10 μ m, compared with the non-sliding surface.	The leakage at the left condition is estimated to be nearly equal to the above leakage.
Push rod	 <p>This is to be replaced when the top end has worn more than 1 mm.</p>	
Play at operating section	The pin, shaft, and joint of the operating section are to be replaced when their plays become more than 2 mm due to wears or so on.	When a play is due to looseness of a tightened section, adjust it.
Operation stability	When abnormal noises, hunting, primary pressure drop, etc. are generated during operation, and these cannot be remedied, referring to section 6 troubleshooting, replace the related parts.	

Notes 1. It is desirable to replace seal materials, such as O-rings, every disassembling. However, they may be reused, after being confirmed to be free of damage.

2. TORQUE CHART

Use following table for unspecified torque.

1) BOLT AND NUT

(1) Coarse thread

Bolt size	8.8T		10.9T		12.9T	
	kgf · m	lbf · ft	kgf · m	lbf · ft	kgf · m	lbf · ft
M 6×1.0	0.8 ~ 1.2	5.8 ~ 8.6	1.2 ~ 1.8	8.7 ~ 13.0	1.5 ~ 2.1	10.9 ~ 15.1
M 8×1.25	2.0 ~ 3.0	14.5 ~ 21.6	2.8 ~ 4.2	20.3 ~ 30.4	3.4 ~ 5.0	24.6 ~ 36.1
M10×1.5	4.0 ~ 6.0	29.0 ~ 43.3	5.6 ~ 8.4	40.5 ~ 60.8	6.8 ~ 10.0	49.2 ~ 72.3
M12×1.75	6.8 ~ 10.2	50.0 ~ 73.7	9.6 ~ 14.4	69.5 ~ 104	12.3 ~ 16.5	89.0 ~ 119
M14×2.0	10.9 ~ 16.3	78.9 ~ 117	16.3 ~ 21.9	118 ~ 158	19.5 ~ 26.3	141 ~ 190
M16×2.0	17.9 ~ 24.1	130 ~ 174	25.1 ~ 33.9	182 ~ 245	30.2 ~ 40.8	141 ~ 295
M18×2.5	24.8 ~ 33.4	180 ~ 241	34.8 ~ 47.0	252 ~ 340	41.8 ~ 56.4	302 ~ 407
M20×2.5	34.9 ~ 47.1	253 ~ 340	49.1 ~ 66.3	355 ~ 479	58.9 ~ 79.5	426 ~ 575
M22×2.5	46.8 ~ 63.2	339 ~ 457	65.8 ~ 88.8	476 ~ 642	78.9 ~ 106	570 ~ 766
M24×3.0	60.2 ~ 81.4	436 ~ 588	84.6 ~ 114	612 ~ 824	102 ~ 137	738 ~ 991
M30×3.5	120 ~ 161	868 ~ 1164	168 ~ 227	1216 ~ 1641	202 ~ 272	1461 ~ 1967

(2) Fine thread

Bolt size	8.8T		10.9T		12.9T	
	kgf · m	lbf · ft	kgf · m	lbf · ft	kgf · m	lbf · ft
M 8×1.0	2.1 ~ 3.1	15.2 ~ 22.4	3.0 ~ 4.4	21.7 ~ 31.8	3.6 ~ 5.4	26.1 ~ 39.0
M10×1.25	4.2 ~ 6.2	30.4 ~ 44.9	5.9 ~ 8.7	42.7 ~ 62.9	7.0 ~ 10.4	50.1 ~ 75.2
M12×1.25	7.3 ~ 10.9	52.8 ~ 78.8	10.3 ~ 15.3	74.5 ~ 110	13.1 ~ 17.7	94.8 ~ 128
M14×1.5	12.4 ~ 16.6	89.7 ~ 120	17.4 ~ 23.4	126 ~ 169	20.8 ~ 28.0	151 ~ 202
M16×1.5	18.7 ~ 25.3	136 ~ 182	26.3 ~ 35.5	191 ~ 256	31.6 ~ 42.6	229 ~ 308
M18×1.5	27.1 ~ 36.5	196 ~ 264	38.0 ~ 51.4	275 ~ 371	45.7 ~ 61.7	331 ~ 446
M20×1.5	37.7 ~ 50.9	273 ~ 368	53.1 ~ 71.7	384 ~ 518	63.6 ~ 86.0	460 ~ 622
M22×1.5	51.2 ~ 69.2	370 ~ 500	72.0 ~ 97.2	521 ~ 703	86.4 ~ 116	625 ~ 839
M24×2.0	64.1 ~ 86.5	464 ~ 625	90.1 ~ 121	652 ~ 875	108 ~ 146	782 ~ 1056
M30×2.0	129 ~ 174	933 ~ 1258	181 ~ 245	1310 ~ 1772	217 ~ 294	1570 ~ 2126

- (12) Tapping lightly shaft ends of drive shafts (111, 113) with plastic hammer, take out drive shafts from swash plate supports.

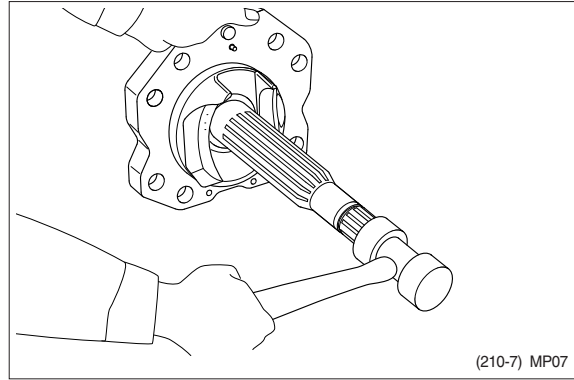

- (13) Remove valve plates (313, 314) from valve block (312).
※ These may be removed in work (6).

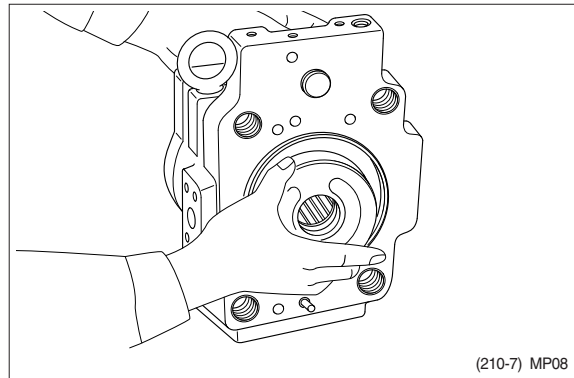

- (14) If necessary, remove stopper (L, 534), stopper (S, 535), servo piston (532) and tilting pin (531) from pump casing (271), and needle bearing (124) and splined coupling (114) from valve block (312).
- ※ In removing tilting pin, use a protector to prevent pin head from being damaged.
 - ※ Since loctite is applied to fitting areas of tilting pin and servo piston, take care not to damage servo piston.
 - ※ Do not remove needle bearing as far as possible, except when it is considered to be out of its life span.
 - ※ Do not loosen hexagon nuts of valve block and swash plate support.
If loosened, flow setting will be changed.

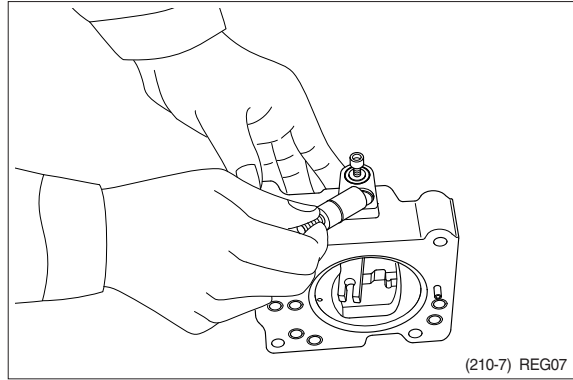

- (9) Remove lever 2 (613). Do not draw out pin (875).
※ Work will be promoted by using pincers or so on.

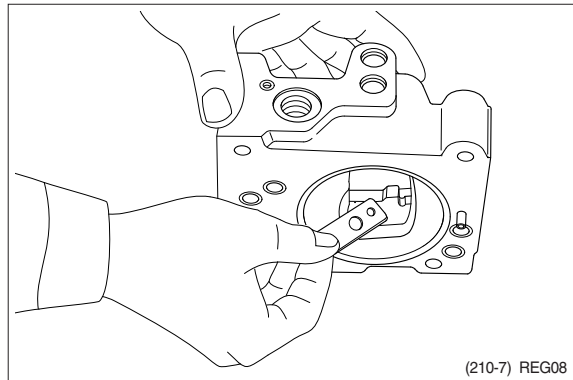

- (10) Draw out pin (874) and remove feedback lever (611).
Push out pin (874, 4 mm in dia.) from above with slender steel bar so that it may not interfere with lever (1, 612).

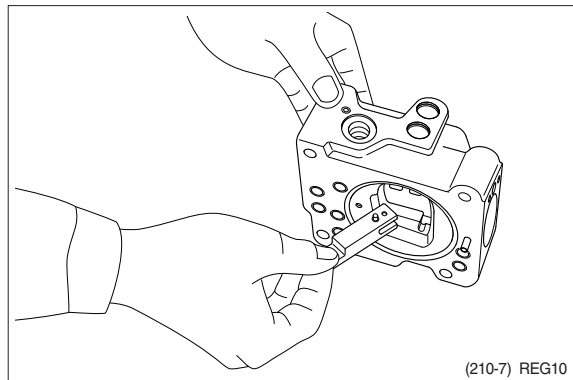
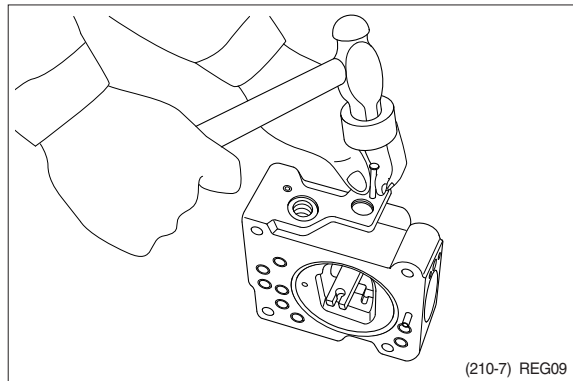

3. DISASSEMBLY AND ASSEMBLY

1) GENERAL PRECAUTIONS

- (1) All hydraulic components are manufactured to a high precision. Consequently, before disassembling and assembling them, it is essential to select an especially clean place.
- (2) In handling a control valve, pay full attention to prevent dust, sand, etc. from entering into it.
- (3) When a control valve is to be removed from the machine, apply caps and masking seals to all ports. Before disassembling the valve, recheck that these caps and masking seals are fitted completely, and then clean the outside of the assembly. Use a proper bench for working. Spread paper or a rubber mat on the bench, and disassemble the valve on it.
- (4) Support the body section carefully when carrying or transferring the control valve. Do not lift by the exposed spool, end cover section etc.
- (5) After disassembling and assembling of the component it is desired to carry out various tests (for the relief characteristics, leakage, flow resistance, etc.), but hydraulic test equipment is necessary for these tests. Therefore, even when its disassembling can be carried out technically, do not disassemble such components that cannot be tested, adjusted, and so on. Additionally one should always prepare clean cleaning oil, hydraulic oil, grease, etc. beforehand.

2) TOOLS

Before disassembling the control valve, prepare the following tools beforehand.

Name of tool	Quantity	Size (mm)
Vice mounted on bench (soft jaws)	1 unit	
Hexagon wrench	Each 1 piece	5, 6, 10, 12 and 14
Socket wrench	Each 1 piece	27 and 32
Spanner	Each 1 piece	32 (main relief valve, overload relief valve, negative relief valve) 26 (holding valve)

2. DISASSEMBLY AND ASSEMBLY OF SWING MOTOR

1) STRUCTURE

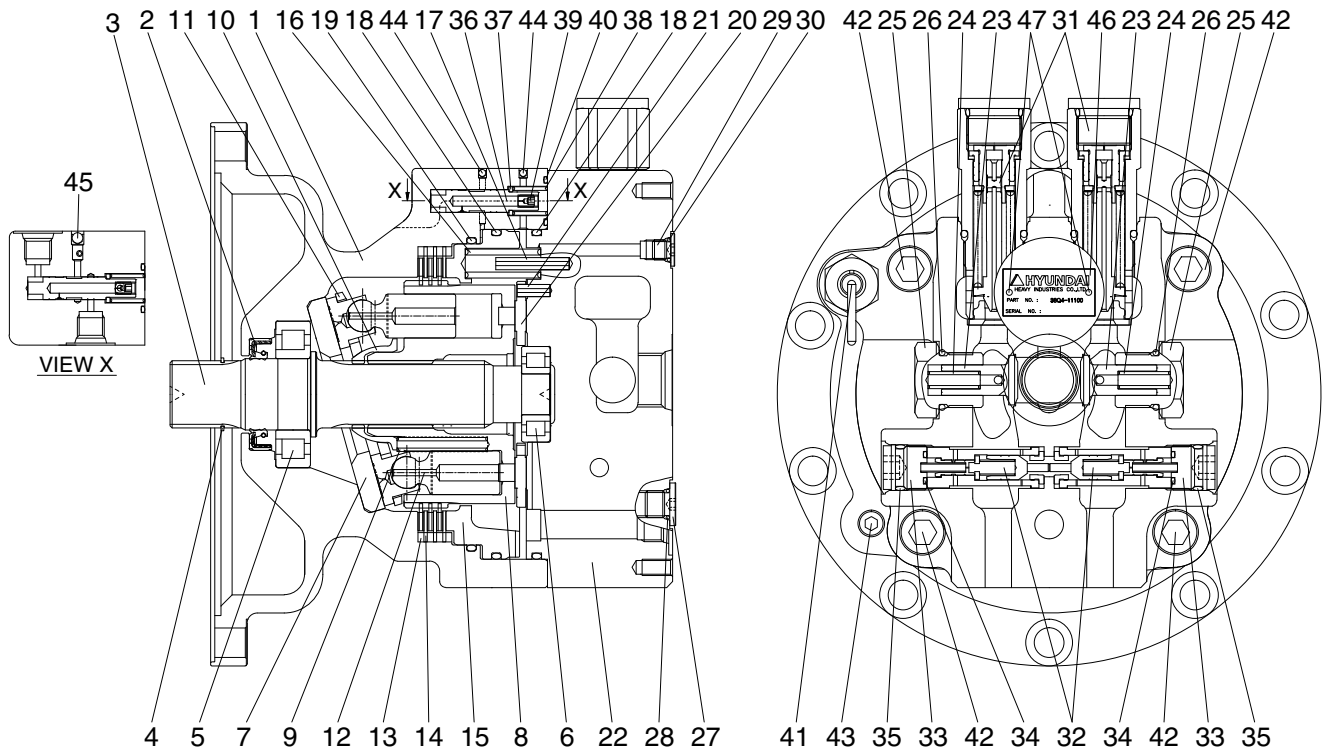

125LCR2SM22

1	Casing	17	Spring pin	33	Plug
2	Oil seal	18	O-ring	34	O-ring
3	Shaft	19	O-ring	35	O-ring
4	Snap ring	20	Valve plate	36	Time delay valve spool
5	Roller bearing	21	Spring pin	37	Spring seat
6	Roller bearing	22	Valve casing	38	Spring
7	Swash plate	23	Check valve	39	Restrictor
8	Cylinder block	24	Spring	40	O-ring
9	Spring	25	Plug	41	Level gauge assy
10	Ball guide	26	O-ring	42	Socket bolt
11	Retainer plate	27	Plug	43	Plug
12	Piston assy	28	O-ring	44	Expander
13	Friction plate	29	Plug	45	Expander
14	Separate plate	30	O-ring	46	Name plate
15	Parking piston	31	Relief valve assy	47	Rivet
16	Spring	32	Anti-rotating valve assy		

(15) Put spring (16) (24EA) in each hole of parking piston.

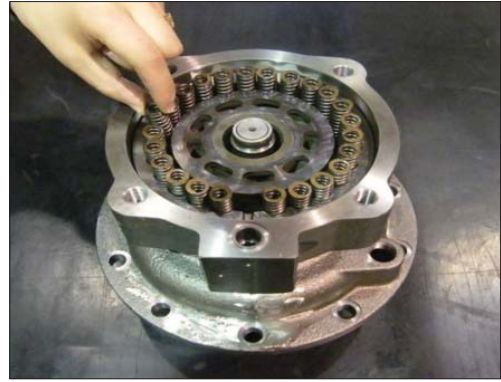

125LCR8SM37

(16) Assemble restrictor (39) in spool (36).
※ Spread loctite #242.



125LCR8SM38

(17) Place spool in casing.



125LCR8SM39

(18) Assemble spring (38) & spring seat (37) in casing.

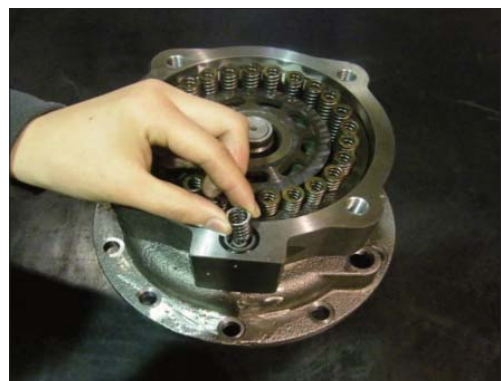

125LCR8SM40

Carrier No.2 sub assy disassembly

(13) After placing spring pin (15) to center of carrier pin No.2 (14) with a press machine, disassemble it.(3 pcs)

※ Do not reuse spring pin.



125LCR8SM72

(14) Disassemble planetary gear No.2.(3 pcs)



125LCR8SM73

(15) Disassemble thrust plate (24).



125LCR8SM74

(16) Disassemble thrust washer No.2 (13).(6 pcs)



125LCR8SM75

(27) Press parallel pin (31) by using press machine.



125LCR8SM110

(28) Spread the loctite #515 on the casing with reference to the right detail view.
※ Loctite should not flow into casing.

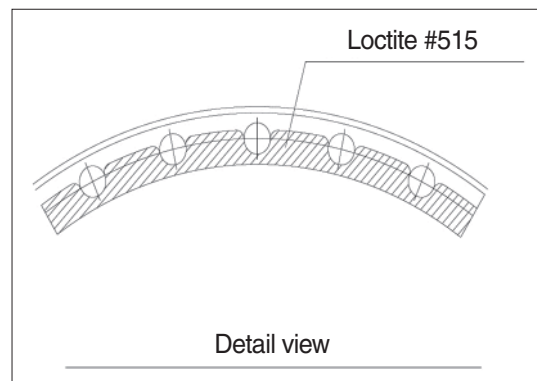

125LCR8SM111

(29) Assemble ring gear (1) in accordance with a pin hole on casing.
※ Be careful of damage of the ring gear.



125LCR8SM112

(30) Assemble carrier No.2 sub assembly.



125LCR8SM113

(8) Complete rotary group.

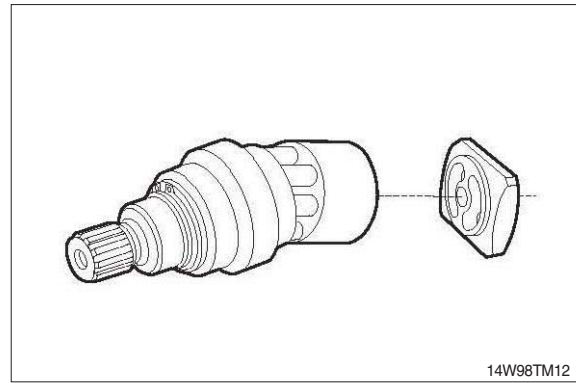

(9) Port plate with control piston.

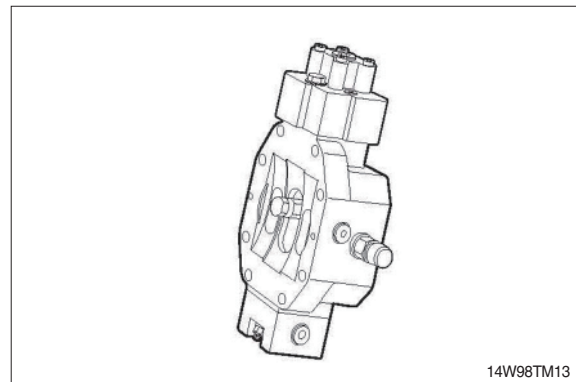

(10) Counter balance valve.

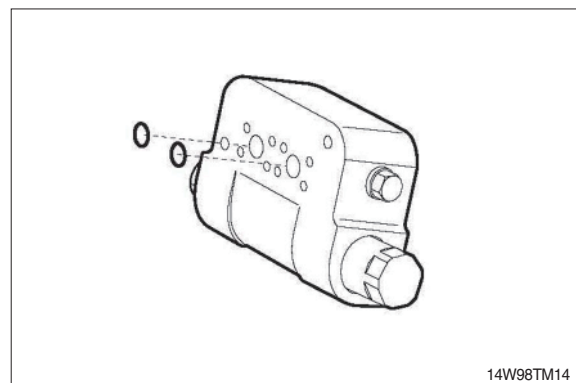

(11) Relief valve.

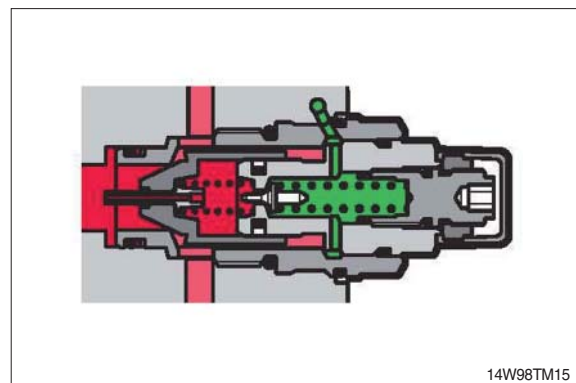

11) INSPECTION INSTRUCTIONS

- (1) Free of corrosion, erosion or fretting; No damage to splines or keyways.

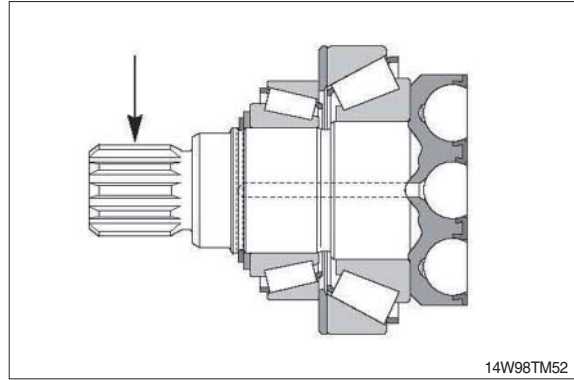

(2) Pistons

- No scoring and no pittings.

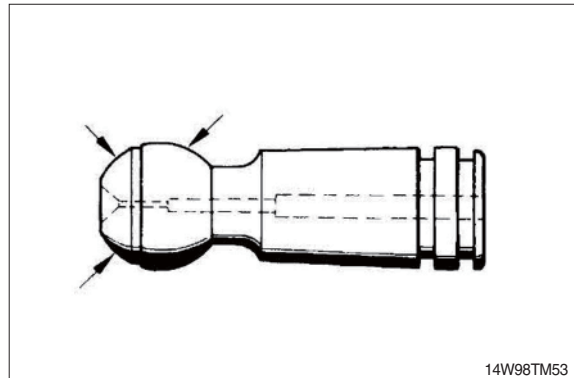

(3) Center pin

- No scoring and no pittings.

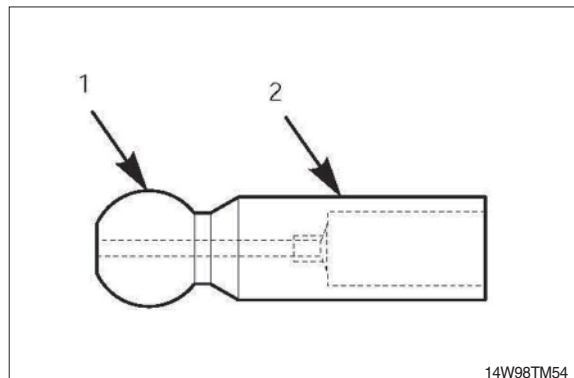

(4) Retaining plate

- No scoring and no evidence of wear.

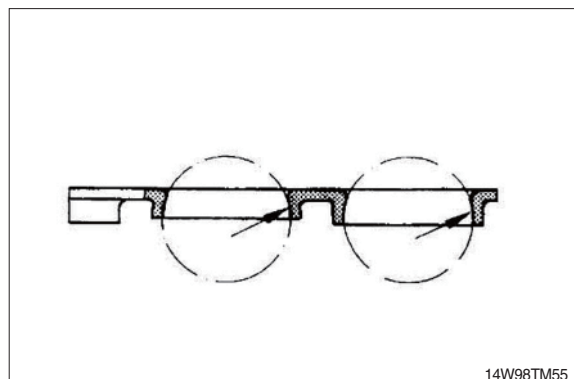

6) Lifting chain

5870 221 047

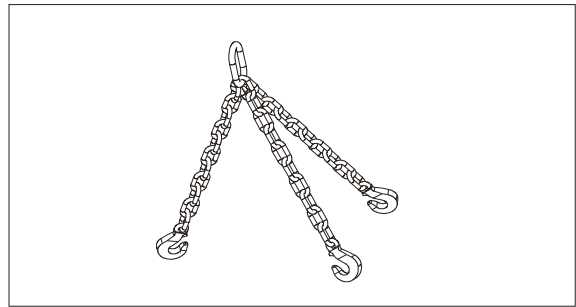

14WF8TM06

7) Resetting device

5870 400 001

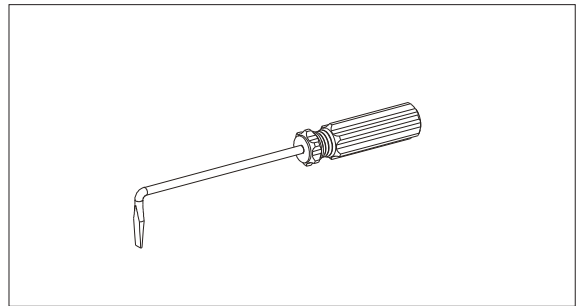

14WF8TM07

8) Clamping pliers

5870 900 021

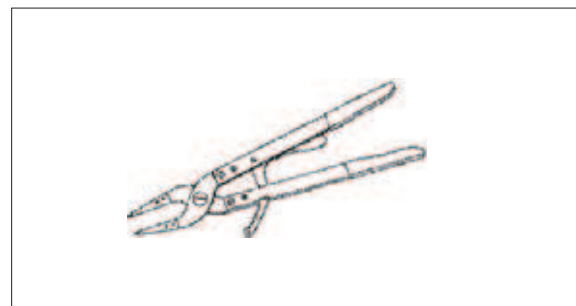

14WF8TM08

9) Clamping fork

5870 240 025

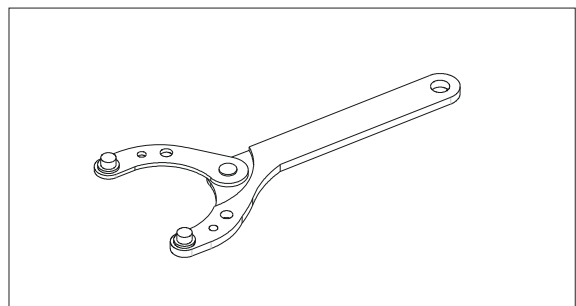

14WF8TM09

10) Extractor

5870 000 017

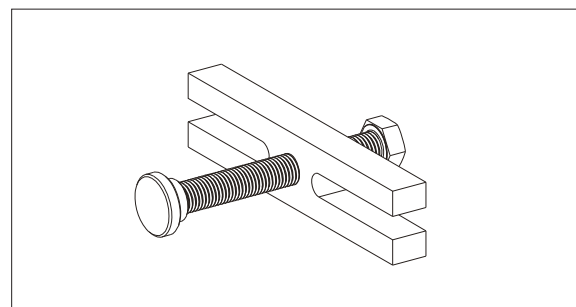

14WF8TM10

10) Lifting chain
5870 281 047



14WF8TM54

11) Pry bar
5870 345 071



14WF8TM55

12) Striker
5870 650 004

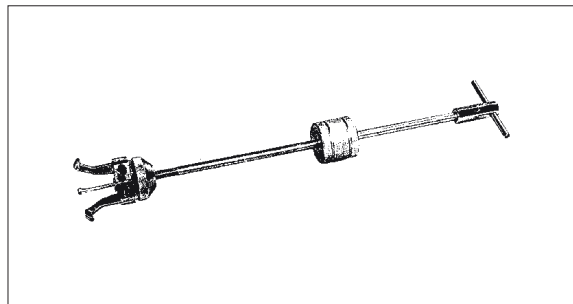

14WF8TM56

13) Set of internal pliers
I1-I2-I3-I4
5870 900 013



14WF8TM57

14) Set of internal pliers
I11-I21-I31-I41 90°
5870 900 014

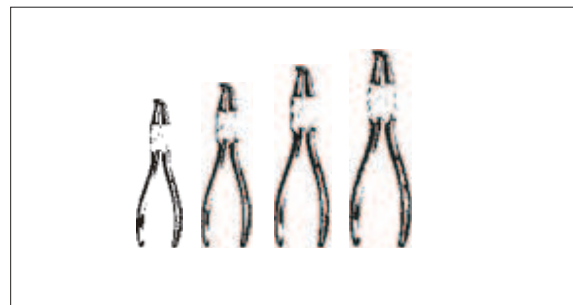

14WF8TM58

24) Take disk package of brake with end plate(s) out of housing.

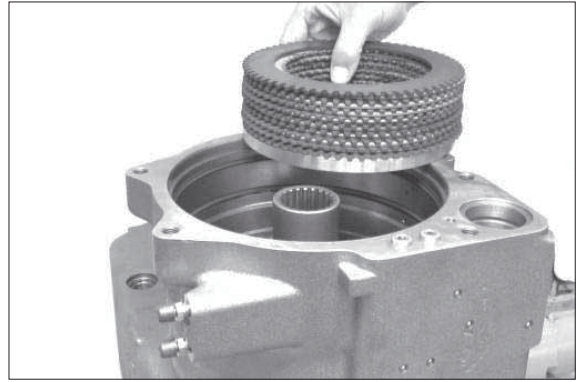

14WF8TM88

25) Disengage retaining ring.

(S) Clamping pliers 5870 900 021

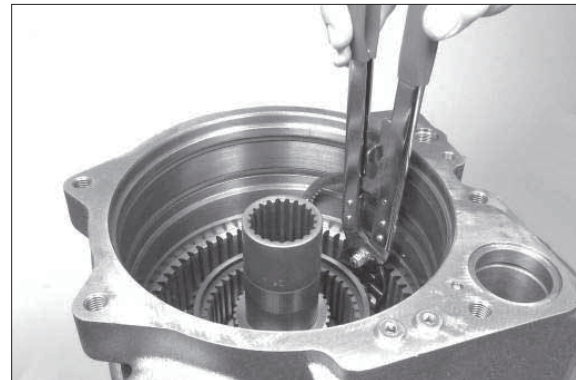

14WF8TM89

26) Remove snap ring and shim.

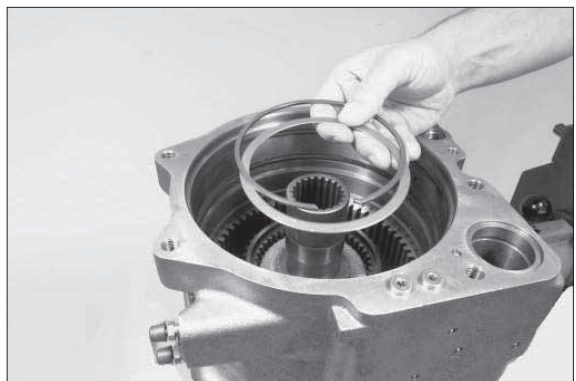

14WF8TM90

27) Take disk package of clutch with end plate(s) out of ring gear.

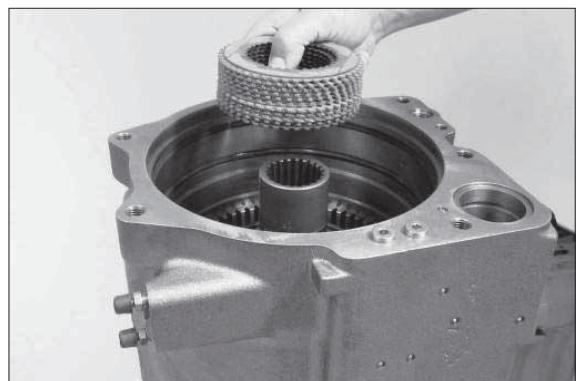

14WF8TM91

Version "Separate installation"

- 15) 1 = Input
- 2 = Output – front axle
- 3 = Output – rear axle

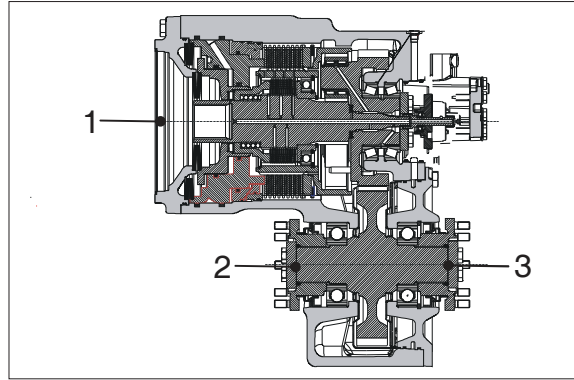

14WF8TM122

- 16) Use clamping fork to fix output flange.
Loosen threaded joint, pull off disk, O-ring and flange.

(S) Clamping fork 5870 240 025

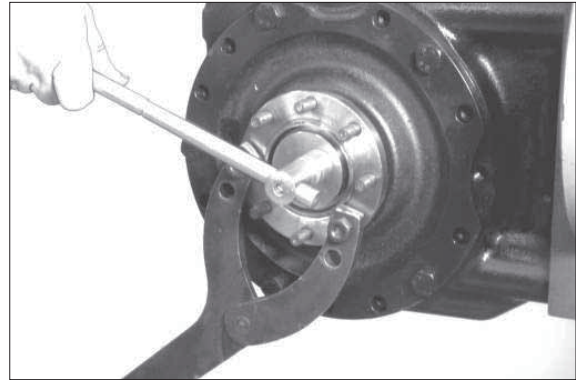

14WF8TM123

- 17) Remove shaft seal with a lever.
※ Disassemble second output flange and shaft seal analogously.

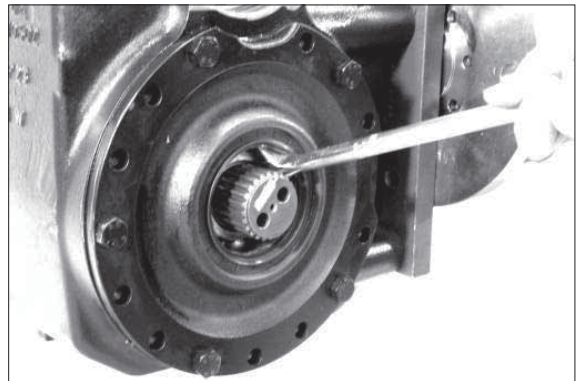

14WF8TM124

- 18) Loosen threaded joint.

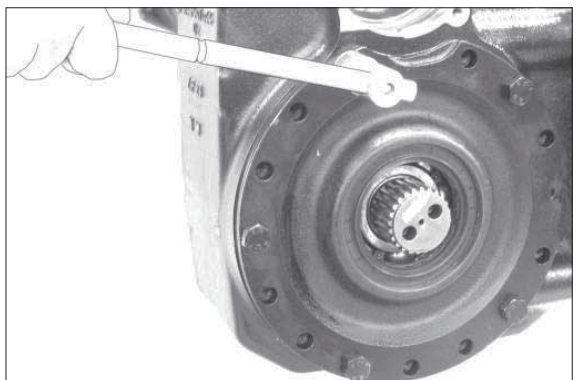

14WF8TM125

27) Turn back pinion fastening / remove clamping bar.

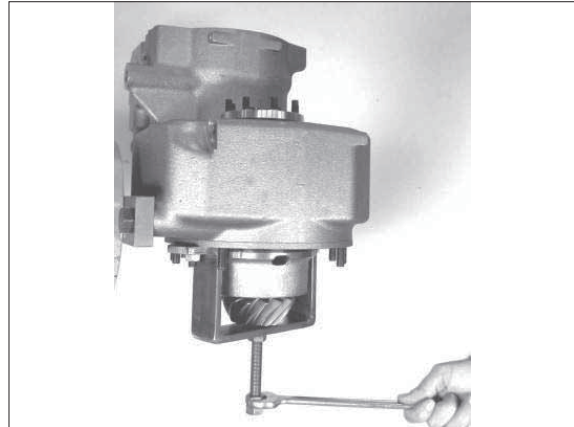

14WF8TM158

Check rolling torque of pinion bearing

28) Bearing rolling torque (without shaft seal)
1.5~4.0 Nm

- ※ When using new roller bearings /for mounted shaft seal, try to achieve the upper value.
- ※ If the required rolling torque deviates, it must be corrected with an adequate adjusting ring (see 14WF8TM154).

(S) Reduction $\frac{1}{2}$ - $\frac{1}{4}$ 5870 656 056
(S) Plug insert AA00 392 461



14WF8TM159

29) Disassemble flange again.



14WF8TM160

- 9) Press bearing inner ring onto planetary carrier until contact.

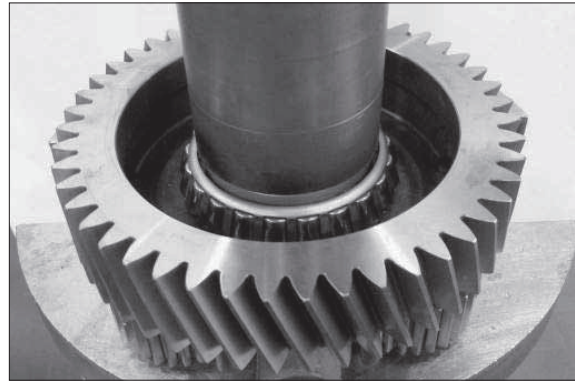

14WF8TM197

- 10) Insert preassembled planetary carrier.

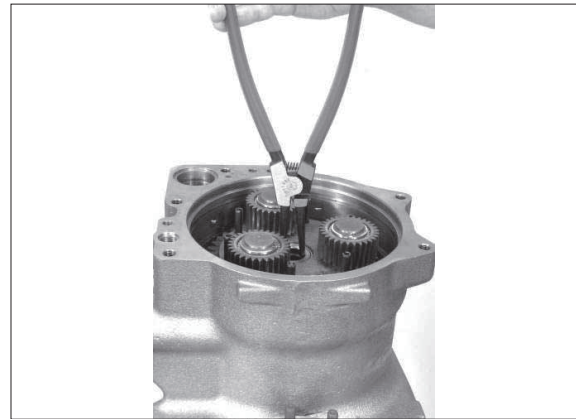

14WF8TM198

- 11) Fix planetary carrier with pressure plate and clamping bar.

(S) Clamping bar

5870 654 049

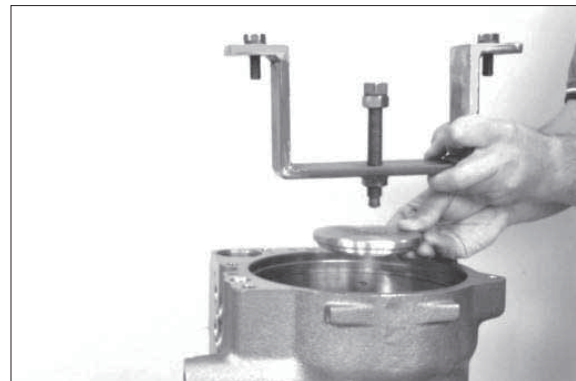

14WF8TM199

- 12) Rotate transmission by 180°.

Check contact of bearing outer ring (see arrow). Reassembly of bearing outer ring, see 14WF8TM189.

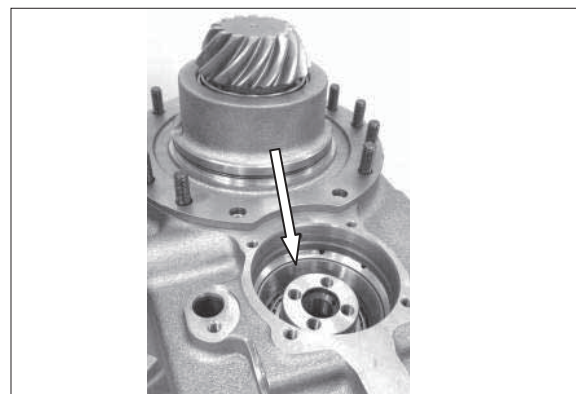

14WF8TM200

45) Oil sealing surfaces in housing and sealing elements. Insert seal (1) with sealing lip showing to oil sump – also see detail sketch.

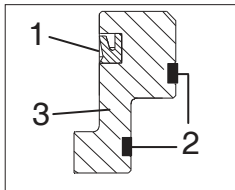

Put both O-rings (2) into annular grooves of pressure ring (3) and insert preassembled pressure ring into housing.

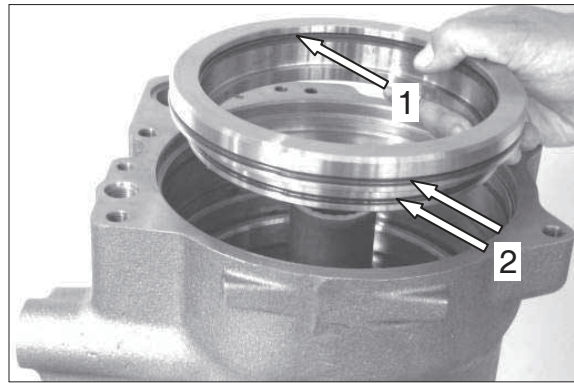

14WF8TM235

46) Bring pressure ring with driver tool into contact position.

(S) Driver tool 5870 506 161



14WF8TM237

47) Insert compression spring until contact.



14WF8TM238

48) Insert pressure piece over compression spring until contact.

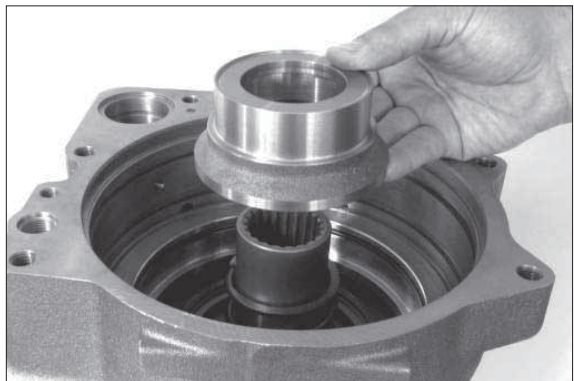

14WF8TM239

- 4) Keep housing in vertical position, while loosening pump cover screws.

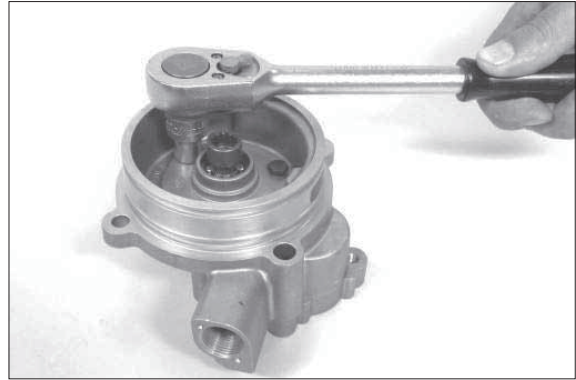

14WF8TM275

※ Maintain contact position of pump and rotate by 180° - disassembly aid.

- 5) Then pull pump in vertical position out of housing – pay attention to possibly releasing balls and compression springs.

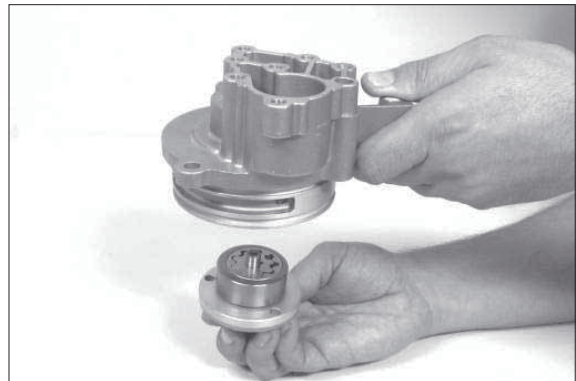

14WF8TM276

- 6) Remove outer (1) and inner rotor (2) and take releasing ball [(3) driver] out of control housing (4).

※ Outer, inner rotor and control housing = rotor set

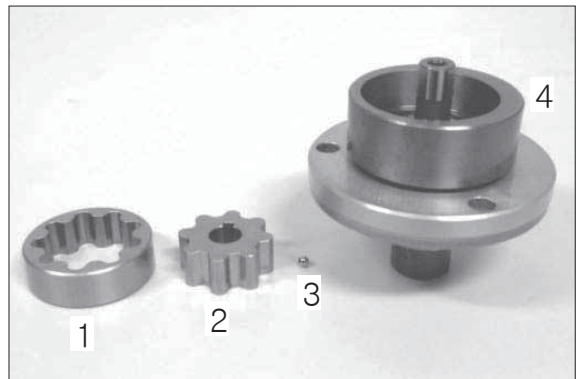

14WF8TM277

- 7) Remove control housing and releasing balls and compression springs (3 pcs. each).

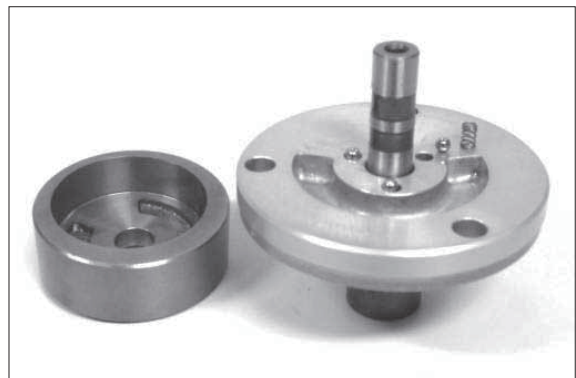

14WF8TM278

13) Oil both O-rings (arrows) and put them into annular groove of housing.

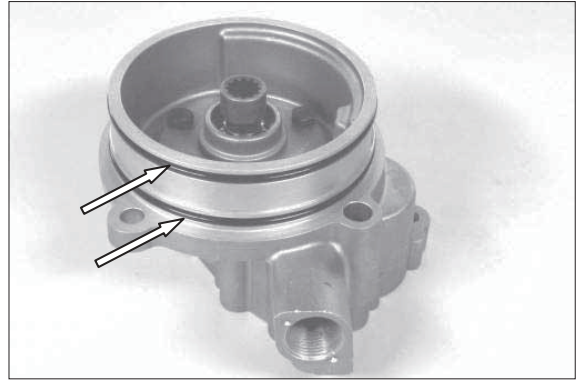

14WF8TM311

14) Insert O-rings (see arrows) into annular grooves of pressure relief valve.

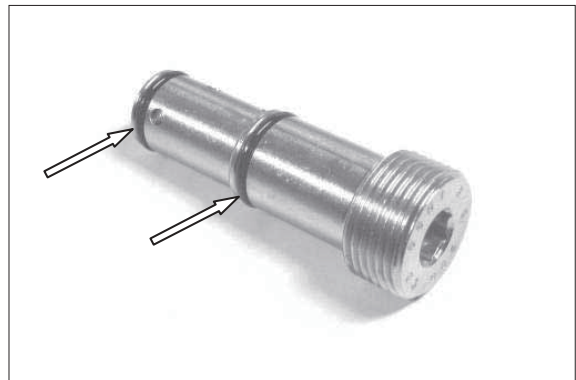

14WF8TM312

15) Mount pressure relief valve.

Tightening torque

$M_A = 10 \text{ Nm}$

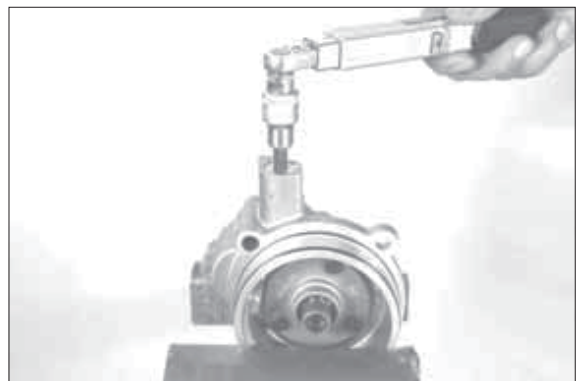

14WF8TM313

16) Secure pressure relief valve by center punch marks (2x).

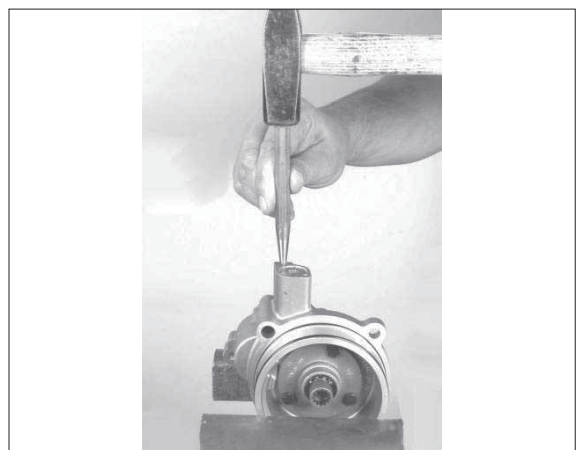

14WF8TM314

29) Mount oil tubes.

Hollow screw (M14×1.5) $M_A = 40 \text{ Nm}$

Hollow screw (M16×1.5) $M_A = 40 \text{ Nm}$

※ Prior to putting the unit into operation,
observe the specifications and regulations.

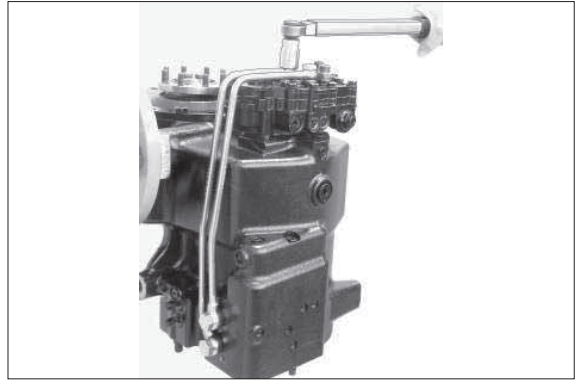

14WF8TM3428

- (9) Take care to keep the cross pin in the sleeve and spool horizontal. The pin can be seen through the open end of the spool. Press the spool inwards and the sleeve, ring, bearing races and needle bearing will be pushed out of the housing together.

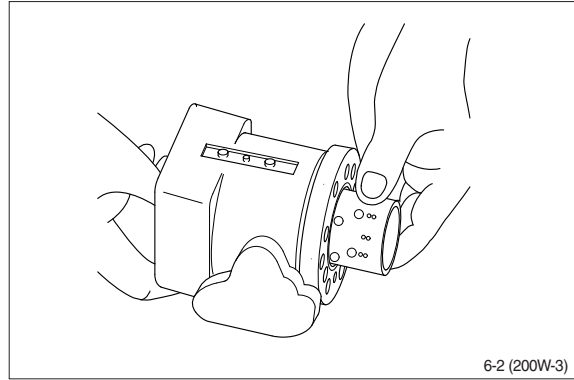

- (10) Take ring, bearing races and needle bearing from sleeve and spool. The outer(thin) bearing race can sometimes "stick" in the housing, therefore check that it has come out.

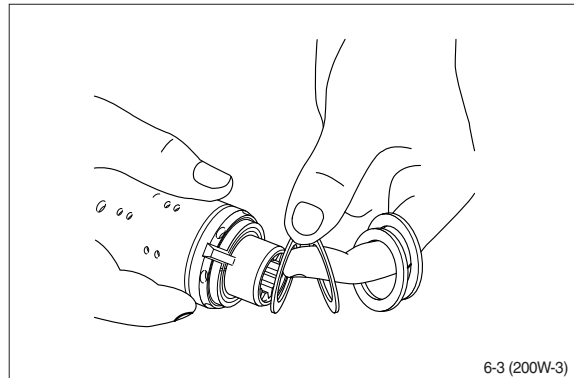

- (11) Press out the cross pin. Use the special screw from the end cover.

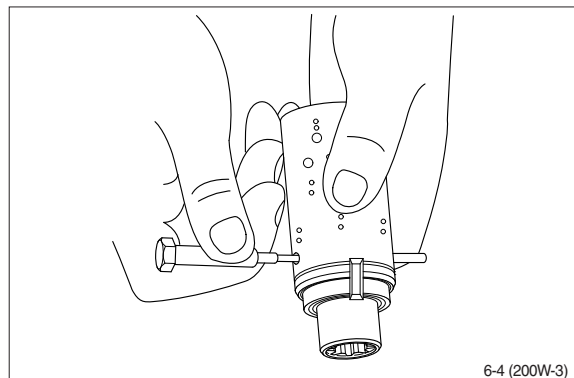

- ※ A small mark has been made with a pumice stone on both spool and sleeve close to one of the slots for the neutral position spring as figure. If the mark is not visible, remember to leave a mark of your own on sleeve and spool before the neutral position springs are disassembled.

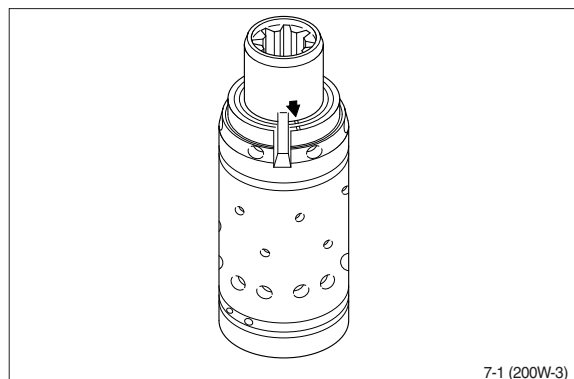

- (14) Draw the inner and outer parts of the assembly tool out of the steering unit bore, leaving the guide from the inner part in the bore.

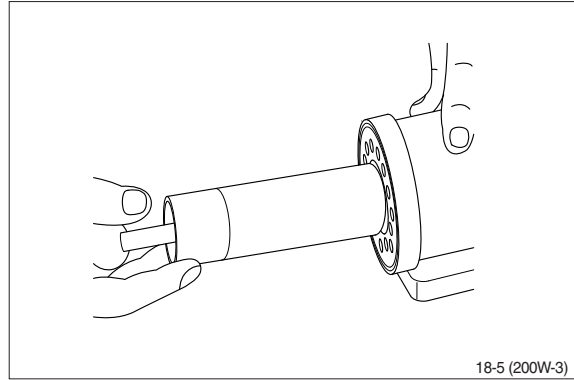

- (15) With a light turning movement, guide the spool and sleeve into the bore.
※ Fit the spool set holding the cross pin horizontal.

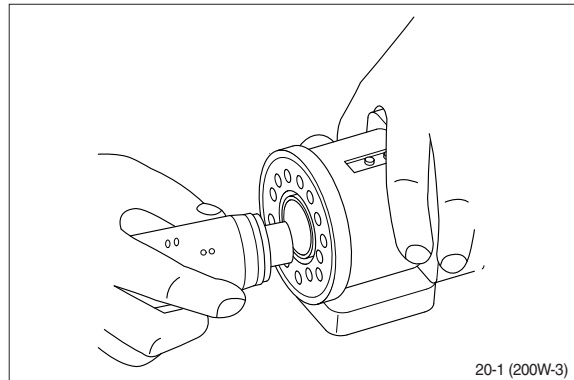

- (16) The spool set will push out the assembly tool guide. The O-ring is now in position.

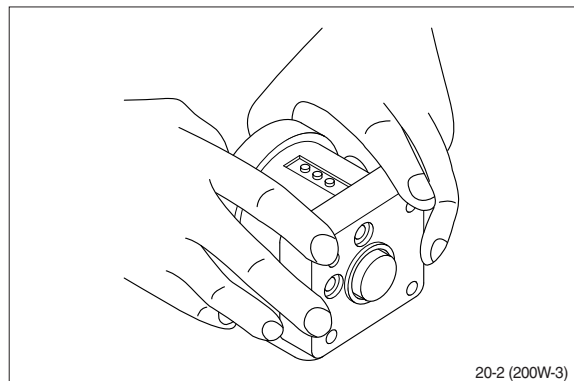

- (17) Turn the steering unit until the bore is vertical again. Put the check valve ball into the hole indicated by the arrow.

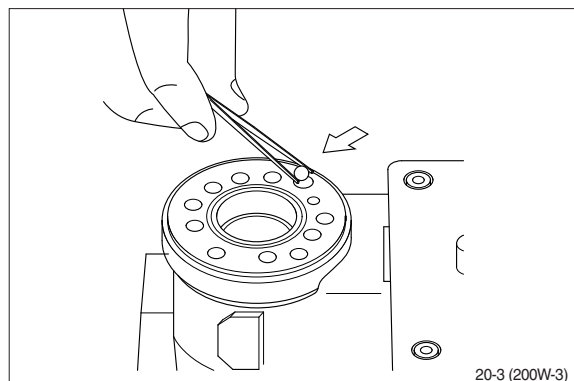

2) IMPORTANT INSTRUCTIONS CONCERNING THE LABOUR SAFETY

- (1) In principle, repairers are themselves responsible for the labour safety.
- (2) The observance of all valid safety regulations and legal rules is a precondition to prevent damage to individuals and products during the maintenance and repair operations.
- (3) Before starting the work, the repairers have to make themselves familiar with these regulations.
- (4) The proper repair of these products requires especially trained personnel.
- (5) The repairer himself is obliged to provide for the training.

3) LUBRICANT SPECIFICATIONS

- (1) Gear oils with limited - slip additives.
- (2) API GL-5
- (3) MIL-L-2105D (SAE 85W-90 LSD or UTTO)

- (21) Use lever to remove tapered roller bearing (1) from bearing pin, remove releasing sealing cap (2) and the O-ring lying behind.

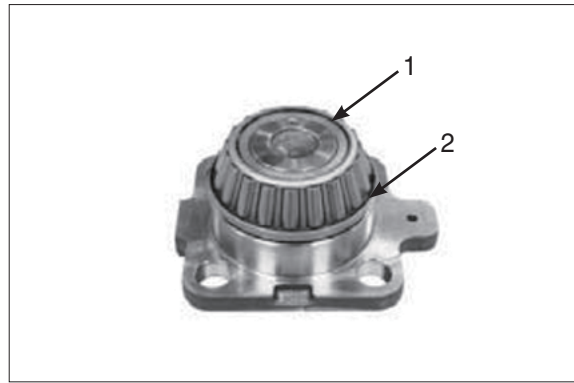

17W98FA033

- (22) Separate knuckle housing with double u-joint shaft from the axle housing.

- ※ Pay attention to shaft seal ring in the axle housing risk of damage.

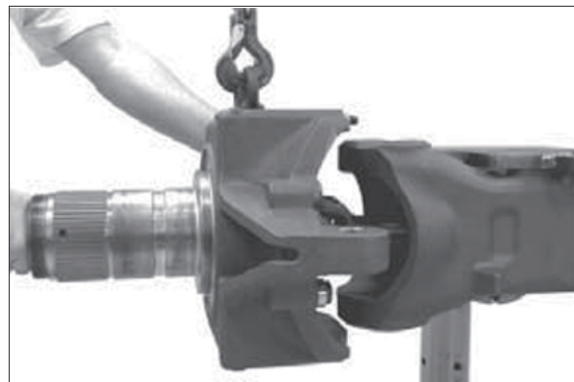

17W98FA034

- (23) Pull out double u-joint shaft from knuckle housing.

- ※ Pay attention to shaft seal ring in the knuckle housing risk of damage.

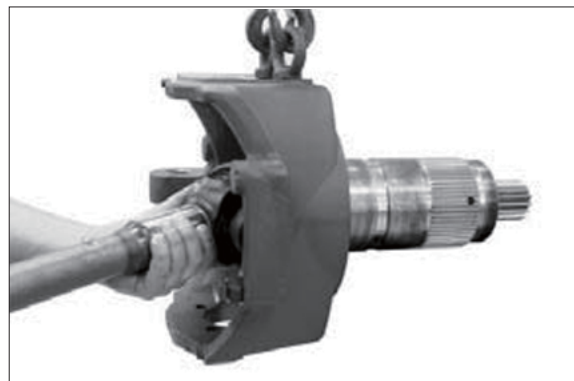

17W98FA035

- (24) Pull out shaft seal ring and afterwards the bushing behind from the axle housing.

(S) Internal extractor 5870 300 007

(S) Counter support 5870 300 020



17W98FA036

(9) Check axial play of the second axle bevel gear 0.0~0.15 mm.

※ If the axial play is not within the specified tolerance, correct with the corresponding outer disks.

After the resetting procedure remove the second axle bevel gear together with the disk package from the differential carrier.

Then oil and reassemble all single parts.



17W98FA072

(10) Mount two adjusting screws (S) and insert cover.

(S) Adjusting screws (M12×1.5)

5870 204 027



17W98FA073

(11) Press crown wheel onto the cover / differential carrier until contact position is obtained.



17W98FA074

(12) Fix differential with press and tighten crown wheel with cylindrical screws.

Tightening torque (M12×1,5/12.9)

. MA = 145 Nm



17W98FA075

※ Just before fitting wet the contact face shaft seal ring/axle drive housing with lubricant.

Apply grease on seal and dust lip of the shaft seal ring.

(4) Comment on sketch:

1 = Axle housing

2 = Shaft seal ring

3 = Bushing

4 = Bearing outer rings (pivot bearing)

Y = Lubrication groove outlet (V-point – in 6 o'clock position and on oil chamber side)

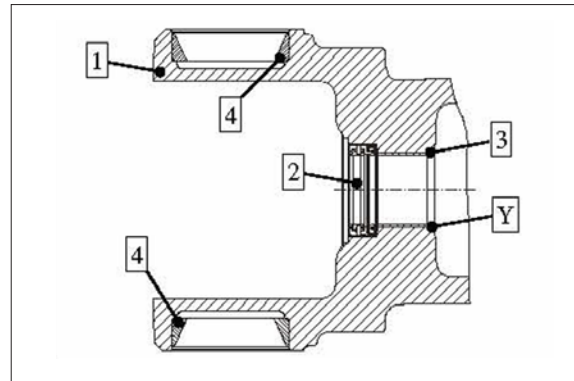

17W98FA106

(5) Insert both bearing outer rings into the pivot bearing holes of the axle housing.

(S) Driver tool 5870 058 058

(S) Handle 5870 260 002

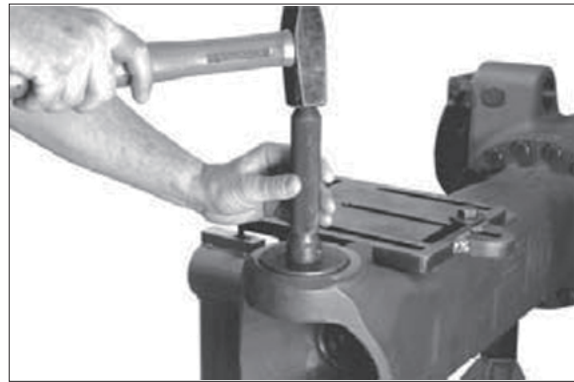

17W98FA107

(6) Install the u-joint shaft by inserting the u-joint shaft into the axle bevel gear teeth.

※ Pay attention to shaft seal ring in the axle housing risk of damage.

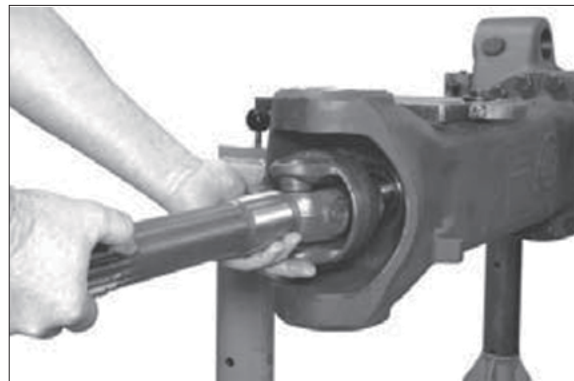

17W98FA108

(7) Knuckle housing (pivot bearing-SET-RIGHT)

Seal machining openings of oil supply holes – position 1 and 2 with plugs.

(S) Lever riveting tongs 5870 320 016

※ Operation is only required when using a new knuckle housing.

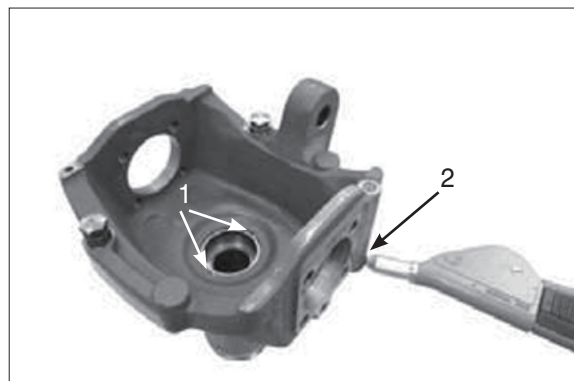

17W98FA109

(11) Fix ring gear with slotted nut.

Tightening torque:

(M 110 x 1.5) MA = 1400 ⁺²⁰⁰ Nm

(S) Socket wrench 5870 656 097

※ First tighten slotted nut with 1400 Nm, then retighten slotted nut until a fixing hole overlaps a threaded hole in the knuckle housing.

While tightening the slotted nut rotate hub in both directions several times roller setting.

※ Wet thread knuckle housing / slotted nut with lubricant.



17W98FA142

(12) Make leakage test of multi-disk brake

Mount threaded coupling (S) and connect HP pump.

(S) HP pump 5870 287 007

(S) Threaded coupling (M14x1.5) 5870 950 102

(S) Breather bottle 5870 286 072

※ Breathe brake completely before starting the test.

Test media :

Motor oils SAE-10W

High-pressure test:

Build up test pressure $p = 100$ bar and close locking valve of HP pump.

A pressure drop by max. 3 bar is permissible during a 5-minute test duration.

Low pressure test:

Reduce test pressure $p = 5$ bar and close locking valve.

No pressure drop is allowed during a 5-minute testing duration.

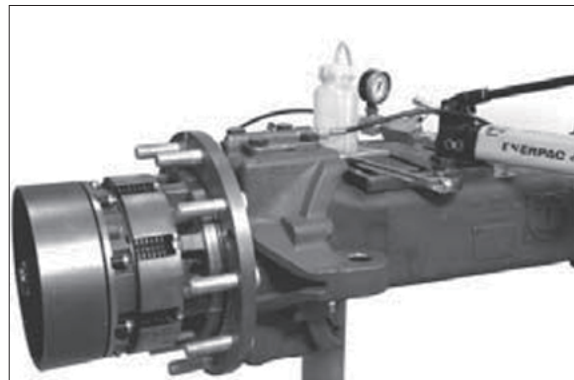

17W98FA143

(19) Steering setting and checking

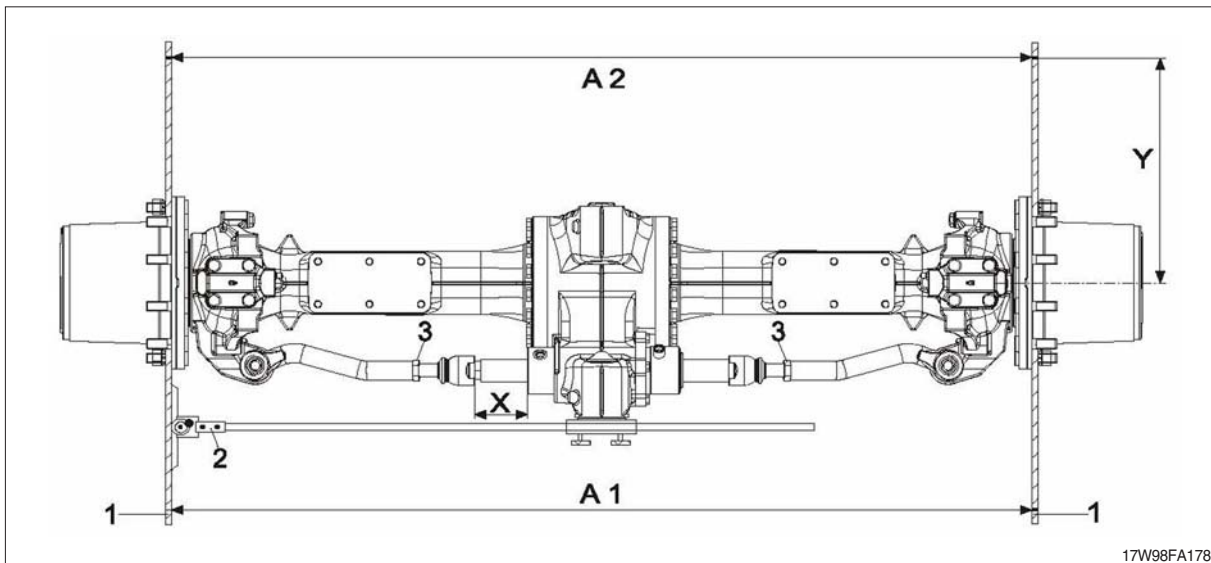

17W98FA178

- 1 = (S) Straightedge 5870 200 029
- 2 = (S) Measuring device 5870 200 033
- 3 = Hexagon nut
- X = Installation dimension (central position – piston rod)
- Y = Distance – wheel center to rim flange

(20) Basic track setting

Bring piston rod in central position.

Dimension X = 119 mm (measured from front face/steering cylinder to contact face/axial joint).

- ※ Do not change axial position of piston rod any more during track setting.

Mount straightedge (1) in horizontal and central axis position.

Fix measuring device (2) to yoke.

Loosen hexagon nut (3) and set length of tie rod (axial joint) until the measuring device (2) indicates 0° (corresponds to a track setting of zero mm).

- ※ For a toe-in and toe-out setting, which might be required, stick to the vehicle manufacturer's specification.

- ※ Make setting on both output sides.

Check track setting (0°):





Determine dimension A1.

Rotate both outputs by 180° – dimension A2 must equal dimension A1.

Dimension "Y" = distance between rim center and rim flange.

Then fix both tie rods (axial joint) by means of hexagon nut (3).

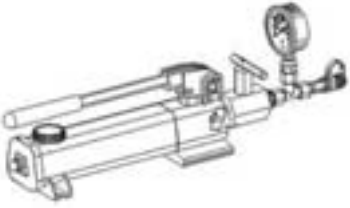
Tightening torque MA = 400 - 450 Nm

No.	Figure	Designation order no.	Qty	Page
36	 <p data-bbox="639 557 746 577">180W9A8FA536</p>	<p data-bbox="770 376 882 405">Driver tool</p> <p data-bbox="770 432 922 461">5870 051 035</p>	1	<p data-bbox="1259 383 1326 412">8-217</p> <p data-bbox="1259 423 1326 452">8-285</p>
37	 <p data-bbox="639 898 746 918">180W9A8FA537</p>	<p data-bbox="770 696 882 725">Driver tool</p> <p data-bbox="770 736 852 766">HW210</p> <p data-bbox="770 792 922 822">5870 051 068</p>	1	-
38	 <p data-bbox="639 1234 746 1254">180W9A8FA538</p>	<p data-bbox="770 1055 874 1084">HP pump</p> <p data-bbox="770 1111 922 1140">5870 287 007</p>	1	<p data-bbox="1233 1061 1353 1090">8-222, 234</p> <p data-bbox="1259 1102 1326 1131">8-290</p>
39	 <p data-bbox="639 1576 746 1597">180W9A8FA539</p>	<p data-bbox="770 1391 975 1420">Threaded coupling</p> <p data-bbox="770 1447 1038 1476">5870 950 102 (M14x1.5)</p>	1	<p data-bbox="1259 1397 1326 1426">8-222</p> <p data-bbox="1259 1442 1326 1471">8-290</p>
40	 <p data-bbox="639 1912 746 1933">180W9A8FA540</p>	<p data-bbox="770 1733 932 1762">Breather bottle</p> <p data-bbox="770 1789 922 1818">5870 286 072</p>	1	<p data-bbox="1259 1740 1326 1769">8-222</p> <p data-bbox="1259 1785 1326 1814">8-290</p>

2. GENERAL INSTRUCTIONS

1) GENERAL WORKING INSTRUCTIONS

- (1) This manual has been developed for the skilled serviceman, trained by the ZF-Passau.
- (2) During all operations, pay attention to cleanliness and skilled working.
Therefore, axle removed from the machine, must be cleaned prior to open them.
- (3) We assume that the special tools, specified by ZF, will be used.
The special tools are available from ZF-Passau.
- (4) After the disassembly, all components must be cleansed, especially corners, cavities and recesses of housing and covers.
- (5) The old sealing compound must be carefully removed.
- (6) Check lubricating holes, grooves and pipes for free passage. They must be free of residues, foreign material or protective compounds.
- (7) The latter refers especially to new parts.
- (8) Parts which have been inevitably damaged in a disassembly operation, must be generally replaced by new ones, e.g. rotary seal rings, O-rings, U-section rings, cap boots, protective caps etc..
- (9) Components such as roller bearings, thrust washers, synchronizing parts etc. which are subject to normal wear in automotive operation, must be checked by the skilled Serviceman.
He will decide if the parts can be reused.
- (10) For the heating of bearings etc., hot plates, rod heaters or heating furnaces must be used.
- (11) Never heat parts directly with the flame. An auxiliary solution would be to immerse the bearing in a vessel filled with oil, which is then heated with the flame.
In this way, damage to the bearings could be avoided.
- (12) Ball bearings, covers, flanges and parts like that must be heated to about 90 to 100°C.
- (13) Hot-mounted parts must be reset after cooling in order to assure a proper contact.
- (14) Before pressing shafts, bearings etc. in position, both parts must be lubricated.
- (15) During to reassembly, all specified adjustment values, testing specifications and tightening torque must be respected.
- (16) After the repair, units are filled up with oil.
- (17) After the oil filling, the oil level plugs and oil drain plugs must be tightened to the specified tightening torque.

- (7) Use striker (S) to pull bearing outer ring out of the bearing hole (axle housing) and remove the releasing shim.

(S) Striker 5870 650 004

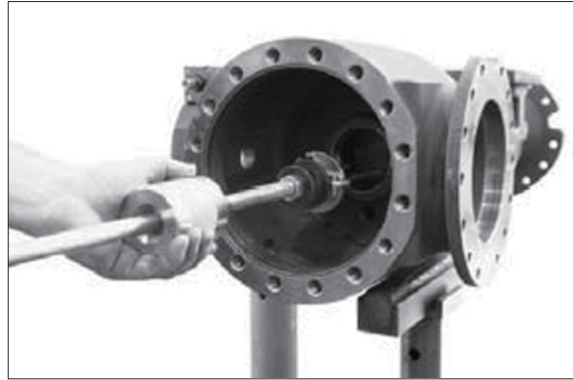

17W98RA029

- (8) Secure axle housing (on crown wheel side, part II) by means of lifting tackle and loosen threaded joint.

Then separate axle housing (part II) from the axle drive housing.

- ※ Pay attention that the differential does not drop.

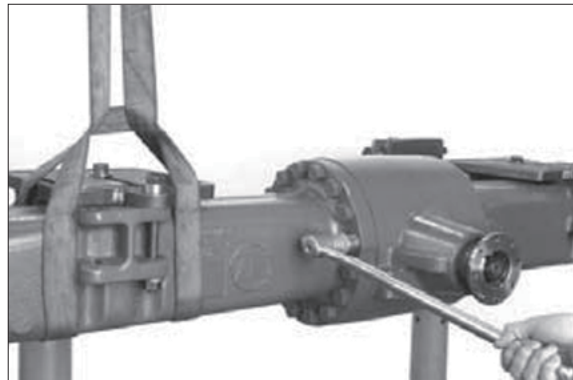

17W98RA030

- (9) Pull bearing outer ring out of the bearing hole and remove the releasing shim.

Then remove O-ring (see arrow).

(S) Striker 5870 650 004

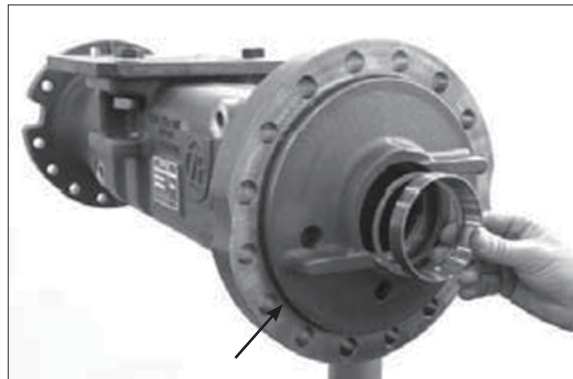

17W98RA031

- (10) Support axle at the axle drive housing (see arrow).

Then lift differential out of the axle drive housing.

- ※ Disassembly of the differential see description on page 8-266 and following.

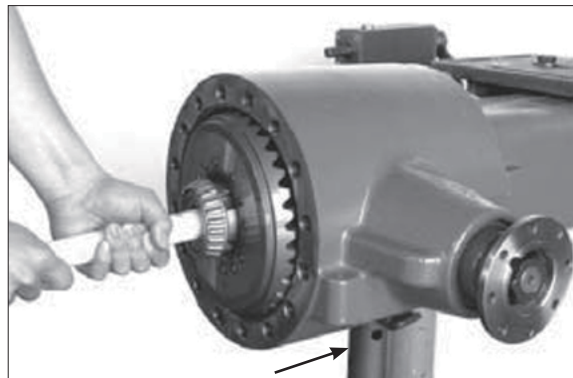

17W98RA032

(2) Test dimension see crown wheel rear side.

※ The test dimension "70" is stamped into the crown wheel rear side. If no + or deviation is indicated, this value corresponds with the test dimension/ actual value "70" in the table below. According to this value, the required shims are allocated in the table below.

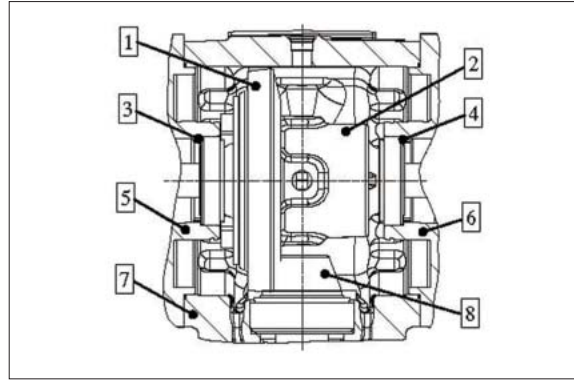

17W98RA066

Any + or - deviation of the test dimension caused by production is also marked on the crown wheel rear side (e.g. 20 or – 10 / 10 or 20) . In accordance with this deviation, the required shims are allocated in the table below.

· Legend to sketch:

- 1 = Crown wheel
- 2 = Differential carrier
- 3 = Shim (crown wheel side)
- 4 = Shim (diff. carrier side)
- 5 = Axle housing
- 6 = Axle housing
- 7 = Axle drive housing
- 8 = Input pinion

Setting disks for differential					
Test dimension/crown wheel marking 70 and deviation	-20	-10	0	10	20
results in → test dim. / actual value	69.80	69.90	70.0	70.10	70.20
Shim/ diff. carrier side Required shim thickness	0.95	1.05	1.15	1.25	1.35
Shim No.	ZGAQ-00545	ZGAQ-00547	ZGAQ-00549	ZGAQ-00552	ZGAQ-00554
Shim/crown wheel side Required shim thickness	1.35	1.25	1.15	1.05	0.95
Shim No.	ZGAQ-00554	ZGAQ-00552	ZGAQ-00549	ZGAQ-00547	ZGAQ-00545

(23) Fitting of shaft seal ring (input flange)

Loosen hexagon nut and pull input flange off the input pinion.

(S) Clamping fork 5870 240 025

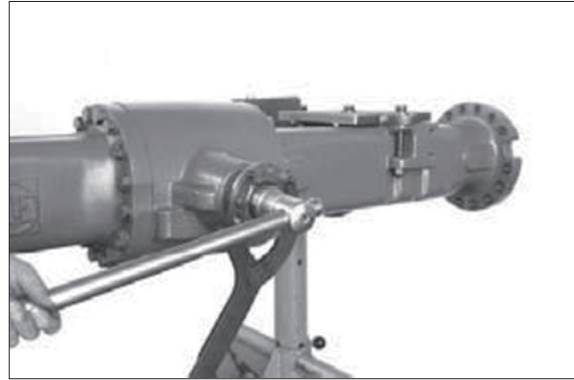

17W98RA099

(24) Legend to sketch:

- 1 = Input pinion
- 2 = Axle drive housing
- 3 = Tapered roller bearing
- 4 = Shaft seal ring
- 5 = Screen sheet
- 6 = Input flange
- 7 = Washer
- 8 = Hexagon nut
- X = Installation dimension → 13.5 +0.2 mm

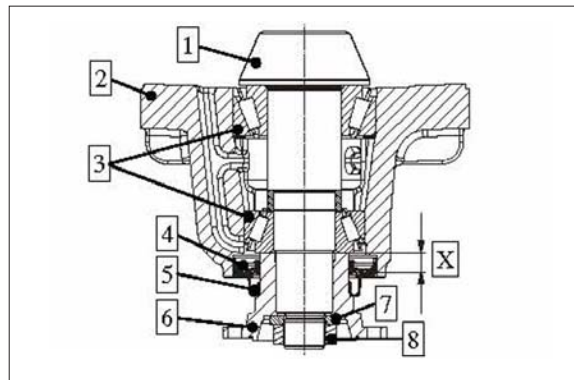

17W98RA100

(25) Mount shaft seal ring with the sealing lip facing the oil chamber.

(S) Driver tool 5870 048 286

- ※ Use of the specified driver tool (S) ensures the exact installation position of the shaft seal ring.
- ※ Just before fitting, apply lubricant to the contact face of shaft seal ring/axle drive housing.
Apply grease to seal and dust lip of the shaft seal ring.

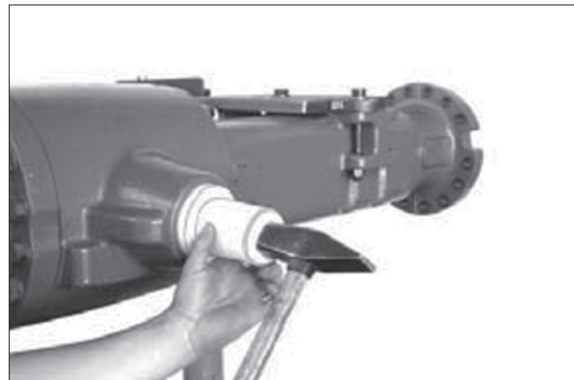

17W98RA101

(26) Mount input flange and finally fix it with washer and hexagon nut.

Tightening torque (M30 x 1.5)
..... MA = 600 Nm

(S) Clamping fork 5870 240 025

- ※ Wet thread of hexagon nut with Loctite no. 262.

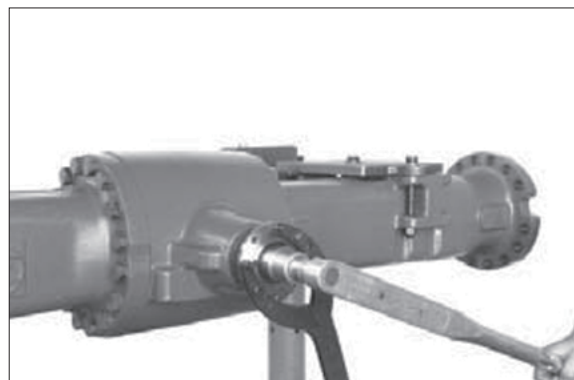

17W98RA102

(34) Fix planetary gear by means of retaining ring.

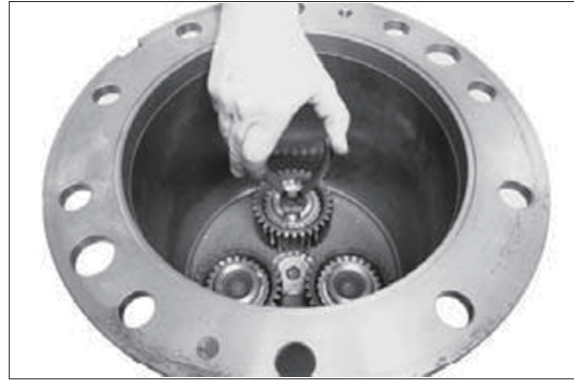

17W98RA136

(35) Mount preassembled planetary carrier and fix it with hexagon screws.

Tightening torque (M12/8.8)
..... MA = 55 Nm



17W98RA137

(36) Output assy

Use lifting tackle (S) to locate the output assy at the axle, mount stub shaft into the teeth of the axle bevel gear and fix output assy with hexagon screws.

Tightening torque (M16/10.9)
..... MA = 280 Nm

(S) Lifting bracket 5870 281 043

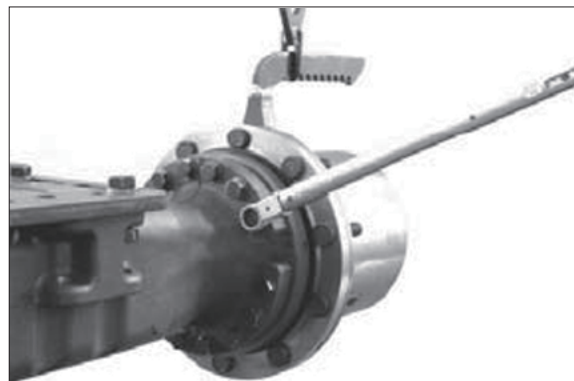

17W98RA138

- ※ Prior to putting the axle into operation, fill in oil.
- Observe the vehicle manufacturer's instructions and specifications for the installation and commissioning of the unit.

4) ASSEMBLY

- (1) Put shim (4), springs (5) and spring seat (6) onto spool (3) in this order.

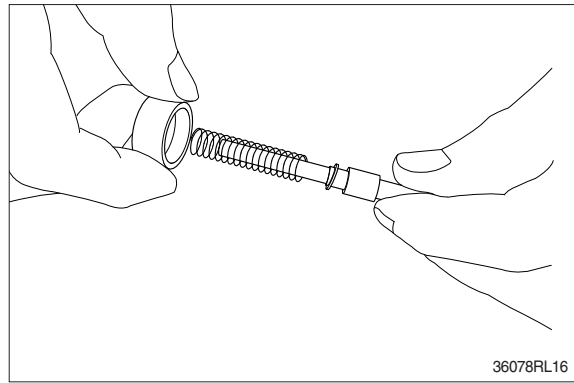

- (2) Assemble spring (7) into casing (1).
Assemble reducing valve subassembly into casing.
※ Assemble them to their original positions.

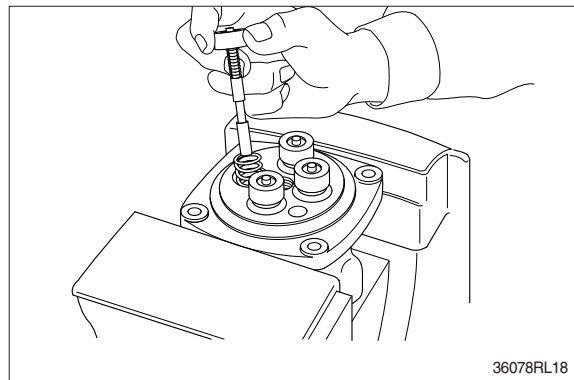

- (3) Assemble O-ring (10) onto plug (8).

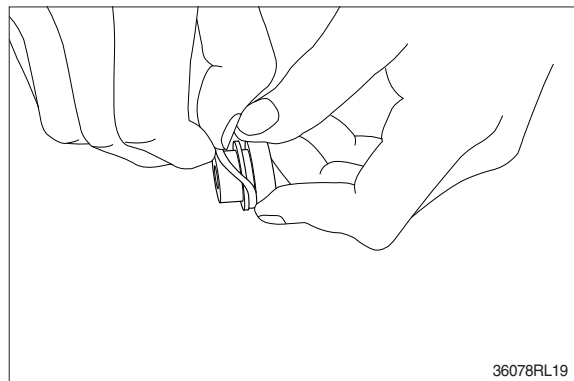

- (4) Assemble seal (11) to plug (8).
※ Assemble seal in such lip direction as shown below.

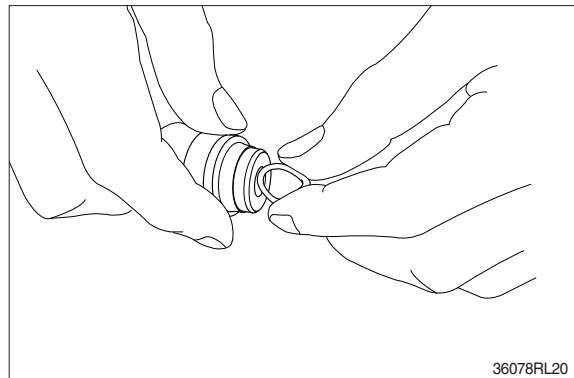

- (5) Fit retainer ring (13), O-ring (7) and wear ring (12) to shaft (2).
- (6) Fit O-ring (9) to hub (1).

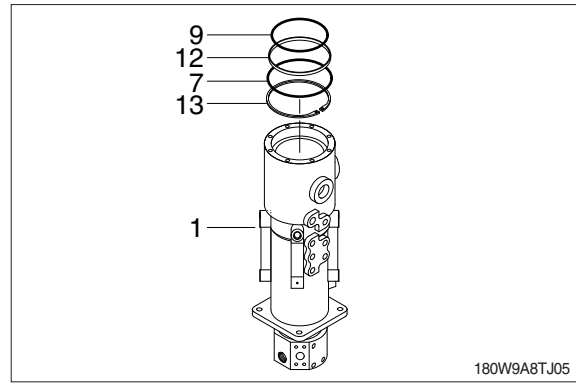

- (7) Install cover (3) to hub and tighten bolts (18).
- Torque : $2.35 \pm 0.35 \text{ kgf} \cdot \text{m}$
($17.0 \pm 2.5 \text{ lbf} \cdot \text{ft}$)

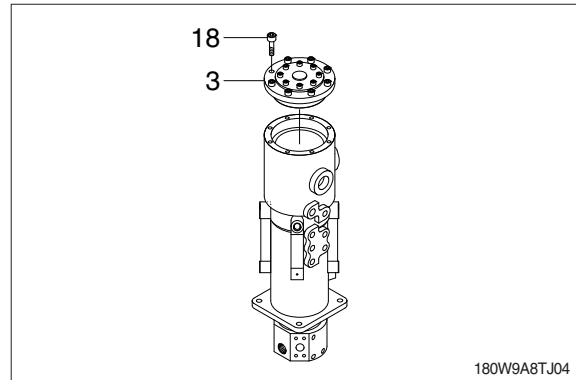

(2) Arm cylinder

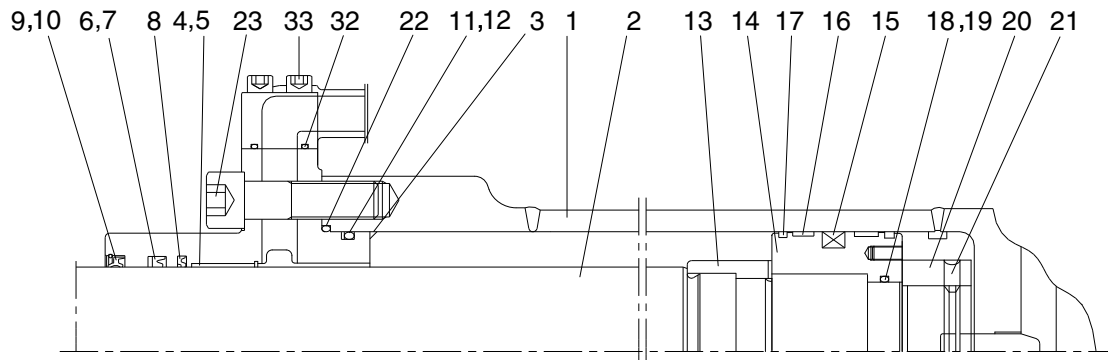

Internal detail

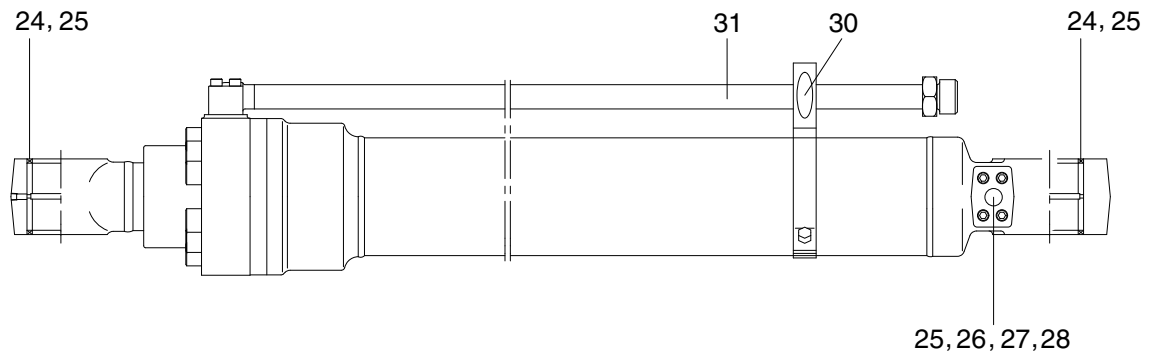

145WF8CY02

1	Tube assembly	12	Back up ring	23	Hexagon socket head bolt
2	Rod assembly	13	Cushion ring	24	Pin bushing
3	Gland	14	Piston	25	Dust seal
4	DD2 bushing	15	Piston seal	26	Check valve
5	Snap ring	16	Wear ring	27	Coil spring
6	Rod seal	17	Dust ring	28	O-ring
7	Back up ring	18	O-ring	29	Plug
8	Buffer ring	19	Back up ring	30	Band assembly
9	Dust wiper	20	Lock nut	31	Pipe assembly-R
10	Snap ring	21	Hexagon socket set screw	32	O-ring
11	O-ring	22	O-ring	33	Hexagon socket head bolt

- ⑤ Fit back up ring (12) to gland (3).
- ※ Put the backup ring in the warm water of 30~50°C.
- ⑥ Fit O-ring (11) to gland (3).

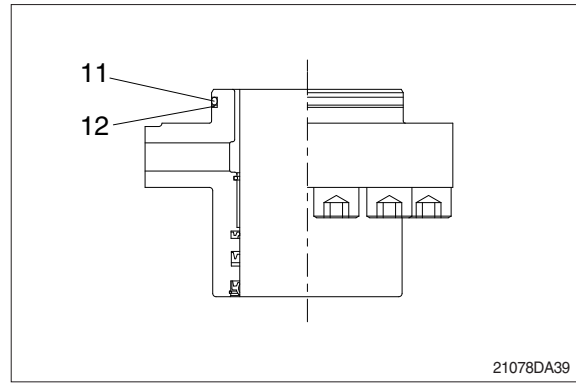

(2) Assemble piston assembly

- ※ Check for scratches or rough surfaces. If found smooth with an oil stone.
- ① Coat the outer face of piston (14) with hydraulic oil.

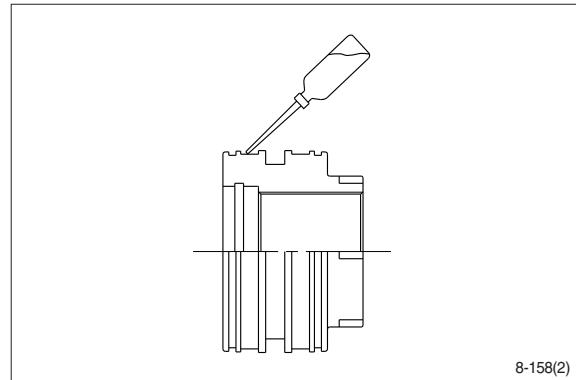

- ② Fit piston seal (15) to piston.
- ※ Put the piston seal in the warm water of 60~100°C for more than 5 minutes.
- ※ After assembling the piston seal, press its outer diameter to fit in.

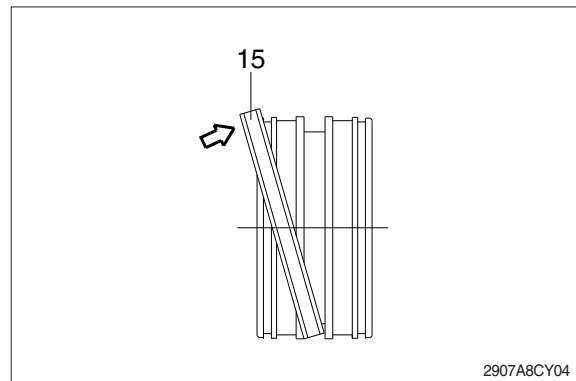

- ③ Fit wear ring (16) and dust ring (17) to piston (14).

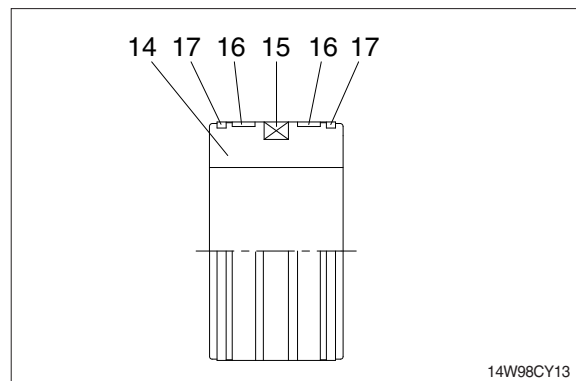

2. COOLING SYSTEM AND FUEL TANK MOUNTING

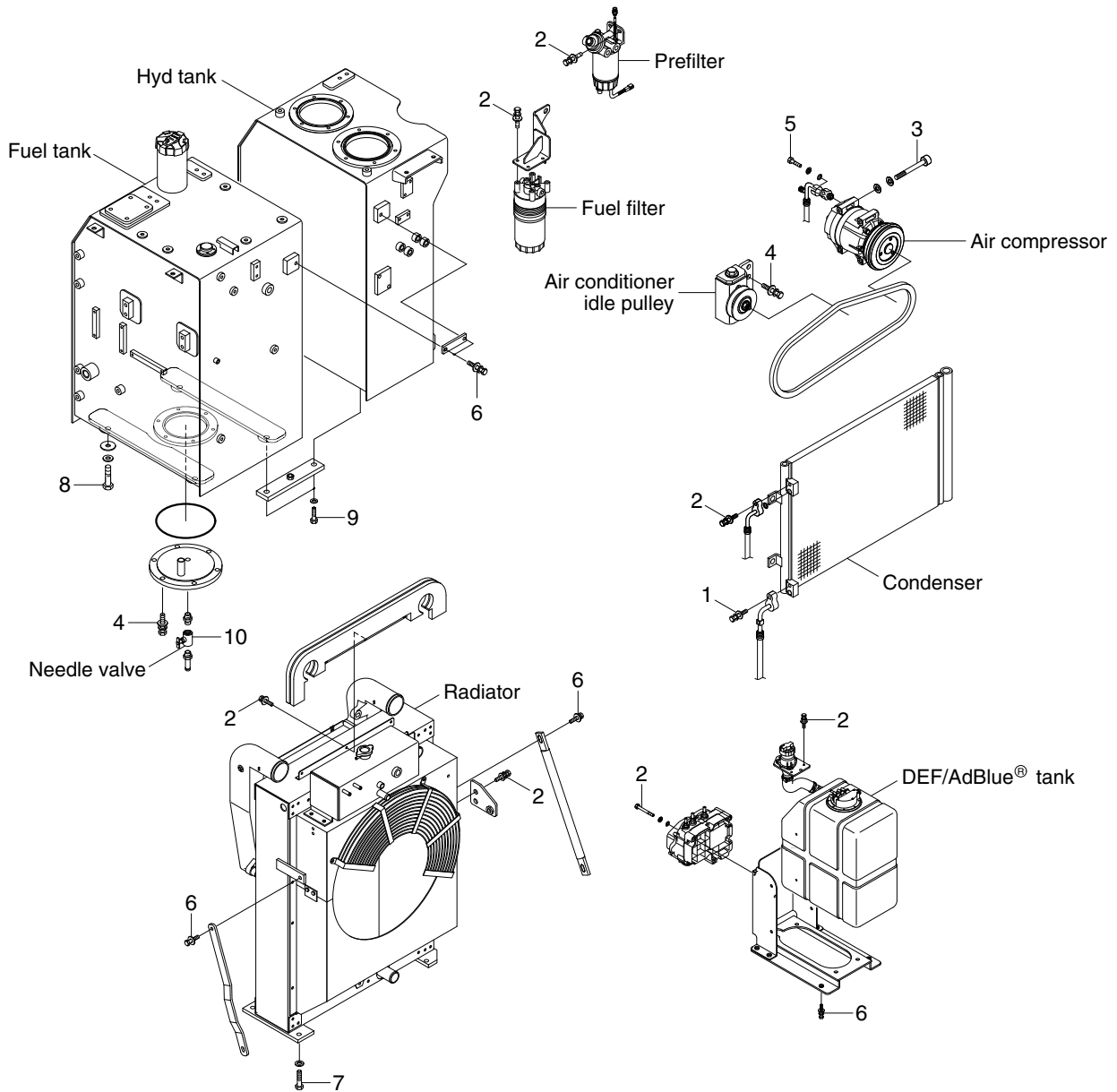

140WF9CM02

· Tightening torque

Item	Size	kgf · m	lbf · ft
1	M 6×1.0	1.05±0.2	7.6±1.45
2	M 8×1.25	2.5±0.5	18.1±3.6
3	M 8×1.25	4.05±0.8	29.3±5.8
4	M10×1.5	6.9±1.4	49.9±10.1
5	M10×1.25	7.4±1.5	53.5±10.8

Item	Size	kgf · m	lbf · ft
6	M12×1.75	12.8±3.0	92.6±21.7
7	M16×2.0	29.7±4.5	215±32.5
8	M20×2.5	57.9±5.8	419±42.0
9	M20×2.5	57.9±8.7	419±62.9
10	-	2.3±0.6	16.6±4.3

CLICK HERE TO **DOWNLOAD** THE COMPLETE MANUAL

- Thank you very much for reading the preview of the manual.
- You can download the complete manual from: www.heydownloads.com by clicking the link below



- Please note: If there is no response to CLICKING the link, please download this PDF first and then click on it.

CLICK HERE TO **DOWNLOAD** THE COMPLETE MANUAL