

## THOMAS EQUIPMENT LIABILITY WARRANTY

THE WARRANTY IS THE ONLY OBLIGATION OF THOMAS OR A THOMAS DEALER TO THE PURCHASER OR ANYONE ELSE CONCERNING A PRODUCT, ITS SERVICE, ITS USE OR PERFORMANCE OR ITS LOSS OF USE OR FAILURE TO PERFORM. NEITHER THOMAS NOR A THOMAS DEALER HAVE MADE AND NEITHER WILL MAKE ANY OTHER EXPRESSED OR IMPLIED REPRESENTATION, WARRANTY OR AGREEMENT CONCERNING A PRODUCT. NEITHER THOMAS NOR A THOMAS DEALER HAVE MADE OR WILL MAKE ANY REPRESENTATION, WARRANTY OR AGREEMENT CONCERNING A PRODUCTS MERCHANTABILITY OR OTHER QUALITY, ITS SUITABILITY FOR PURCHASER'S PURPOSE (EVEN IF A PURCHASER HAS INFORMED THOMAS OR A THOMAS DEALER OF THAT PURPOSE), ITS DURABILITY, PERFORMANCE OR OTHER CONDITION.

EVEN IF THOMAS OR A THOMAS DEALER WAS ADVISED OF THE POSSIBILITY OF SUCH LOSS, NEITHER THOMAS NOR A THOMAS DEALER WILL BE LIABLE TO PURCHASER OR ANYONE ELSE FOR ANY INDIRECT, INCIDENTAL CONSEQUENTIAL, PUNITIVE, ECONOMIC, COMMERCIAL, OR SPECIAL LOSS WHICH IS IN ANY WAY ASSOCIATED WITH A PRODUCT. THIS INCLUDES ANY LOSS OF USE OR NON-PERFORMANCE OF A PRODUCT, ANY REPLACEMENT RENTAL OR ACQUISITION COST, ANY LOSS OF REVENUE OR PROFITS, ANY FAILURE TO REALIZE EXPECTED SAVINGS, ANY INTEREST COSTS, ANY IMPAIRMENT OF OTHER GOODS, ANY INCONVENIENCE OR ANY LIABILITY OF PURCHASER TO ANY OTHER PERSON.

PURCHASER MAY NOT ATTEMPT TO ENLARGE ITS RIGHTS UNDER THE WARRANTY BY MAKING A CLAIM FOR INDEMNITY, FOR BREACH OF CONTRACT, FOR BREACH OF COLLATERAL WARRANTY, FOR A TORT (INCLUDING NEGLIGENCE, MISREPRESENTATION OR STRICT LIABILITY) OR BY CLAIMING ANY OTHER CAUSE OF ACTION.

THE WARRANTY IS A CONDITION OF SALE OF THE PRODUCT TO PURCHASER AND WILL THEREFORE APPLY EVEN IF PURCHASER ALLEGES THAT THERE IS A TOTAL FAILURE OF THE PRODUCT.

*N.B. Read and practice your **Thomas** operating and servicing instructions. Failure to do this may void your warranty.*

*Publication Number 46847*

**February 2001**

CLICK HERE TO **DOWNLOAD** THE COMPLETE MANUAL

- Thank you very much for reading the preview of the manual.
- You can download the complete manual from: [www.heydownloads.com](http://www.heydownloads.com) by clicking the link below



- Please note: If there is no response to CLICKING the link, please download this PDF first and then click on it.

CLICK HERE TO **DOWNLOAD** THE COMPLETE MANUAL



THOMAS

# CONTROL VALVE 1.3

## 1 Control Valve Installation

When installing a new control valve, always inspect the exterior for shipping or other damage, such as bent brackets, broken spring return caps or damaged spool lock mechanism. Repair all damaged parts before installation to the loader.

- 1 Mount the control valve to the loader. (fig. C2324a)

### IMPORTANT

Follow the hydraulic fitting torque chart in Section 1.10 when connecting fittings and lines.

- 2 Connect the control cables to the spools.
- 3 Connect the various hydraulic lines to their proper ports. (fig. C2324b).

### WARNING

Use extreme caution when checking the hydraulic system for leaks. Fluid under pressure can penetrate the skin and cause serious injury.

- 4 Connect the solenoid coils to the control valve locks. Apply a drop of Loctite 242 (blue) to the knurled retaining nut.

### WARNING

All safety switches must be connected and functioning to prevent possible operator injury.

- 5 Verify fluid level in th hydraulic oil reservoir. (fig. C2354). Top off as required to bring oil level to approximately half way in the site gauge.

### WARNING

Verify the relief valve pressure setting after replacing or servicing the control valve.

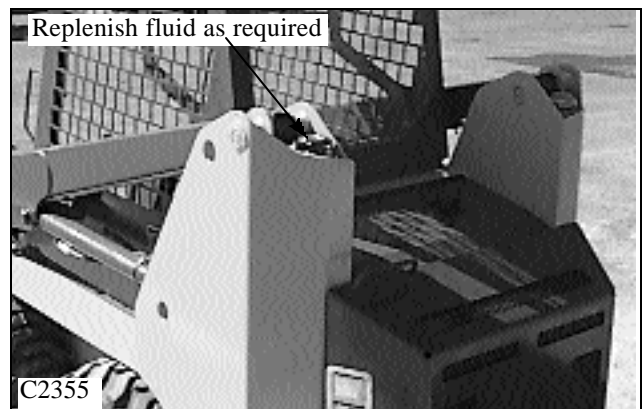
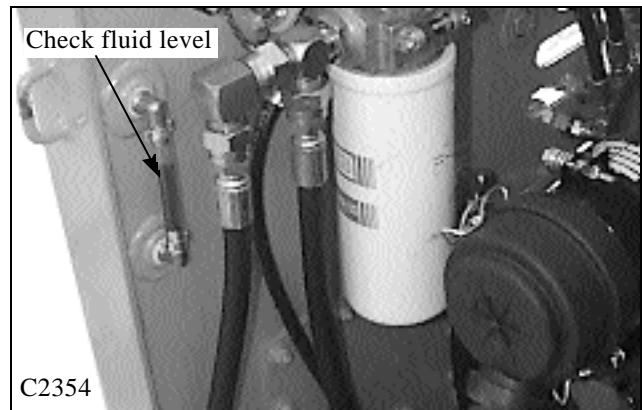
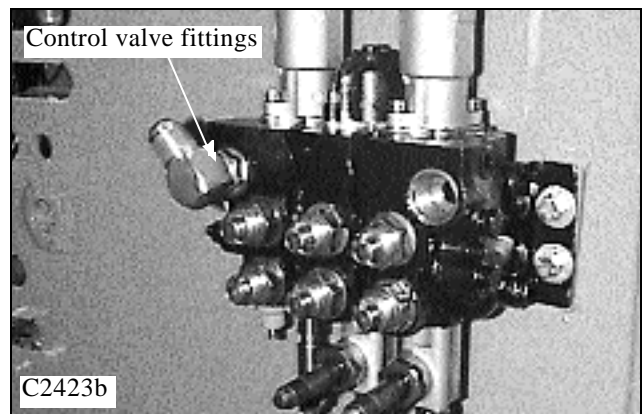
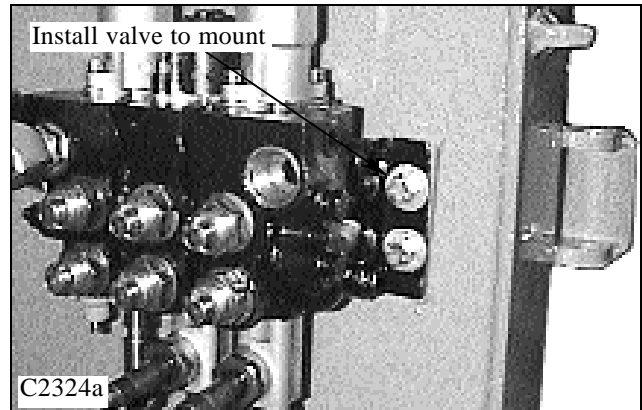

# CONTROL VALVE 1.3

## 1

### Disassembly / Repair (cont'd)

24 Remove and discard the O-ring seals between the sections. Replace with new. Be sure to replace the O-ring seal spacer shim upon assembly. (fig. C2392, C2393). Lubricate the seals with system oil upon assembly. When reassembling the control valve sections, follow the torque specifications in Section 8.

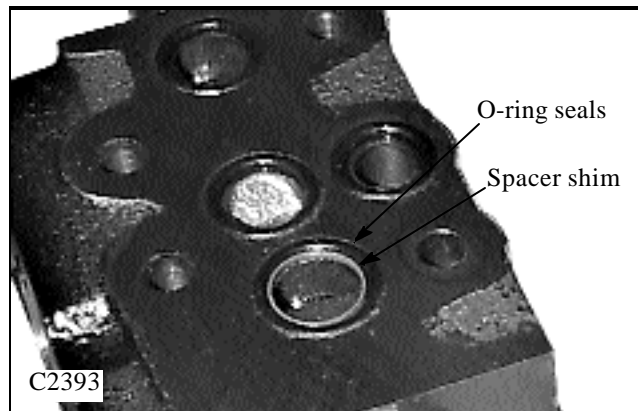
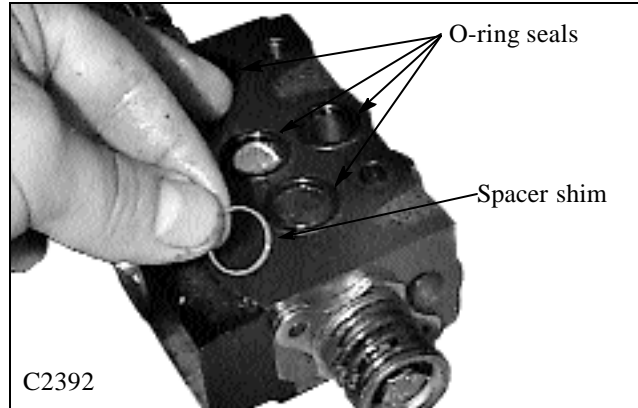

25 To remove the detent mechanism and spring from the spool, place an allen wrench or screwdriver blade through the spool eyelet to hold the spool from turning while removing the spring and detent mechanism. (fig. C2394).

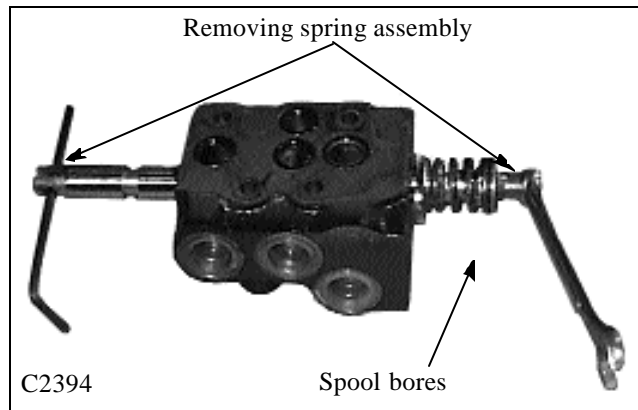

26 Remove the mechanism and arrange the parts in order of placement. (fig. C2395) Inspect the detent part and bushings for burrs and wear. Replace if worn.

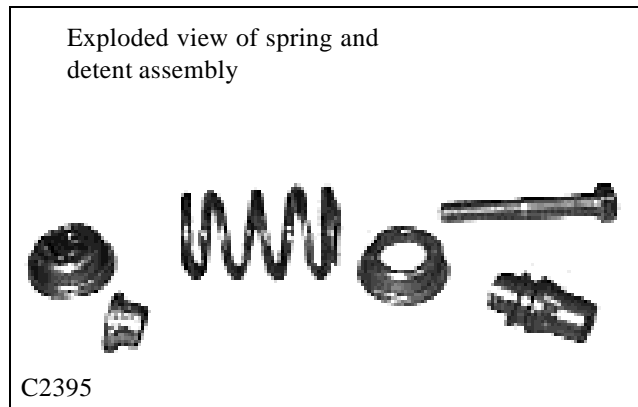

# HYDRAULIC CYLINDERS 1.4

1

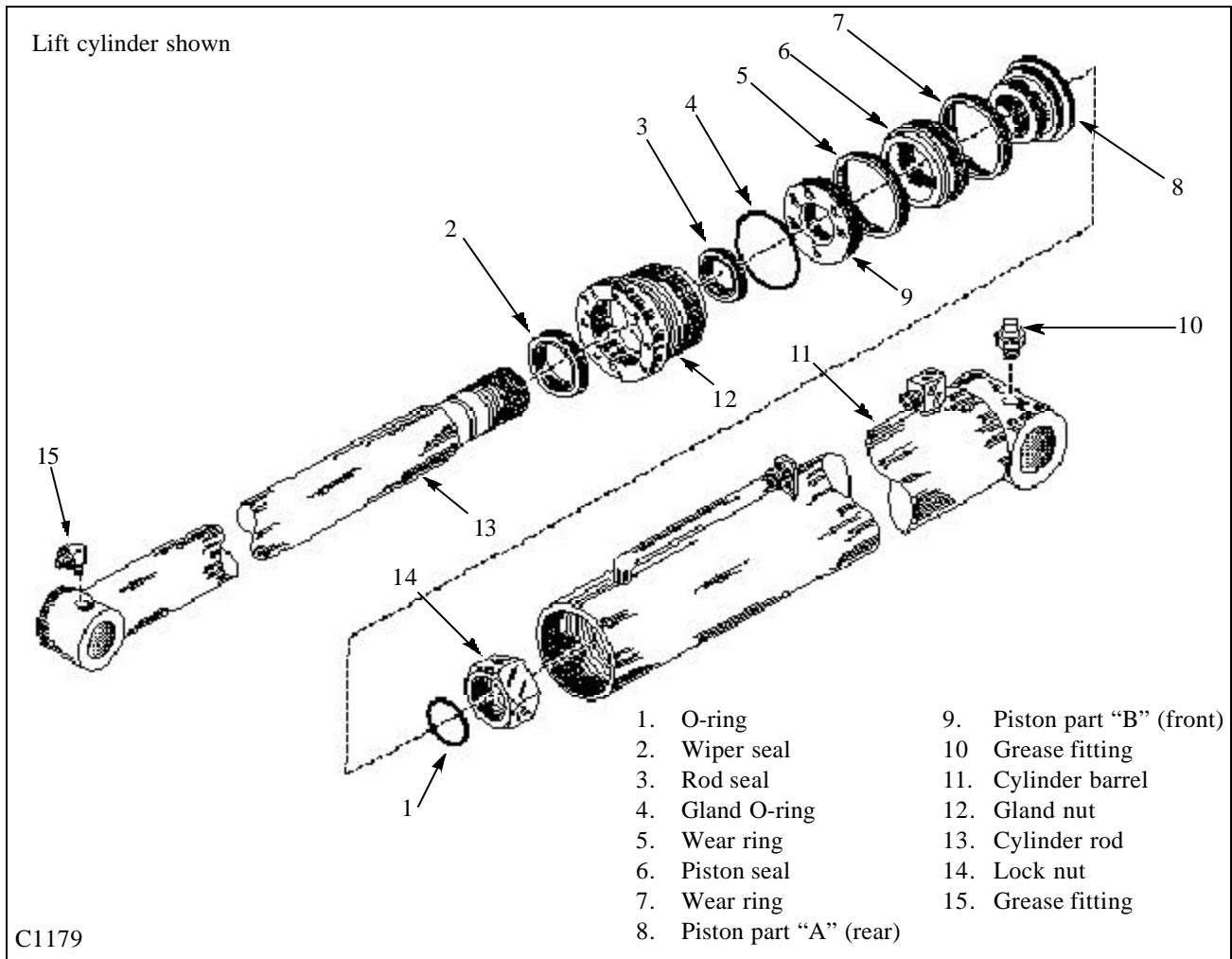

## General Information

All cylinders are a double acting, designed to extend and retract under pressure.

The piston rods, which are made of high strength distortion free material, are precision ground and hard chrome plated. The cylinders barrels are micro honed to close tolerance, straightness and smooth finish for long piston packing seal life.

All cylinders have a 2 piece piston assembly made of ductile iron and a polypac seal arrangement consisting of a piston seal and 2 wear rings.

The rod seal is a "U" cup design, with the "U" facing the pressurized oil. The rod wiper keeps foreign matter from entering the cylinder by wiping the rod clean as the cylinder retracts.

The gland nut seal is of an "O" - ring design. This seal keeps the oil from leaking around the gland nut and cylinder barrel threads.

Certain cylinders have spacers in them. These spacers are used to limit the stroke of the rod.

Some cylinders also have replaceable hardened bushings in the pivot areas that can be serviced when worn out.

# HYDRAULIC OIL RESERVOIR 1.7

## 1

### General Information

The hydraulic oil reservoir is located at the rear of the loader on the left hand side. (fig. C2934) The reservoir is completely separated from all chain and gear drives to eliminate contamination. A magnetic drain plug is installed in the bottom of the reservoir, and a magnet is attached to the 100 micron suction filter, to assist in removing metal particles from the oil.

Oil level is checked through a sight gauge located just inside the engine compartment, left hand side, on the oil reservoir. The proper fill level is marked by a line and should be checked daily. (fig. C2354)

The oil reservoir fill cap is located at the top of the reservoir. (fig. C2355) The oil fill cap assembly has a 30 micron screen to catch larger particles of contaminant before entering the reservoir, but **always use oil filtered through a 10 micron min. filter for replenishing the hydraulic reservoir.** The oil fill cap is also a reservoir vent, or breather, and contains a 10 micron filter to remove air borne particles.

### Checking The Oil Level

- 1 Check the reservoir oil level with the loader on level ground.
- 2 Lower the boom arms, retract the cylinders and engage the parking brake. Shut off the engine.
- 3 Open the rear door. (fig. C2934)
- 4 Check the oil level in the sight gauge. (fig. C2354)
- 5 If oil is visible approximately mid way in the sight gauge, the level is correct.

### Adding Oil

- 1 Remove the bolt, or lock, on the reservoir filler cap.
- 2 Open the filler cap. (fig. C2355)
- 3 Inspect the filler screen in the filler neck for damage. If the filler screen is damaged, replace it.
- 4 Using a clean container, add 10W30 API class SE / CD oil.
- 5 Replace the filler cap and replace the bolt, or padlock, in the cap to prevent vandalism.

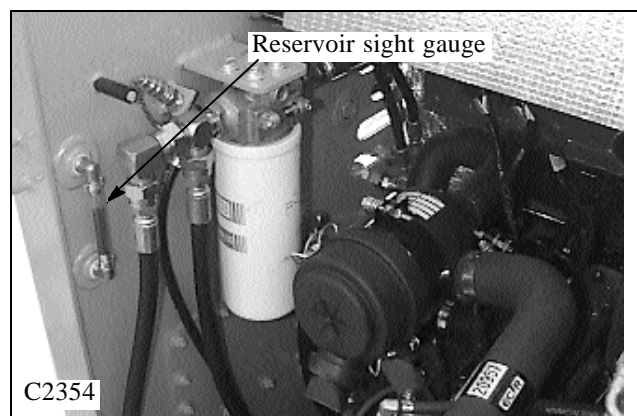
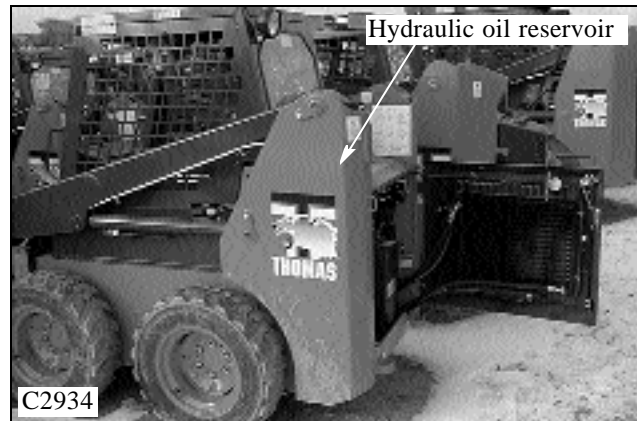

### IMPORTANT

**Always use filtered oil to replenish the hydraulic system.**

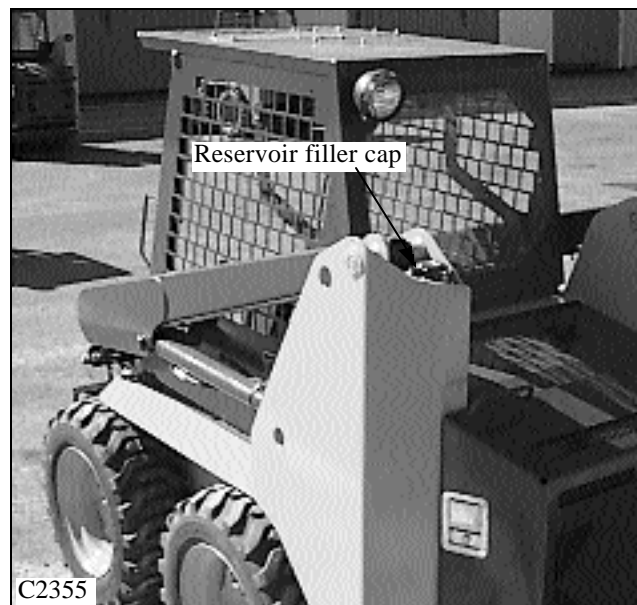

# TROUBLE SHOOTING 2.4

Symptom: Operates In One Direction Only

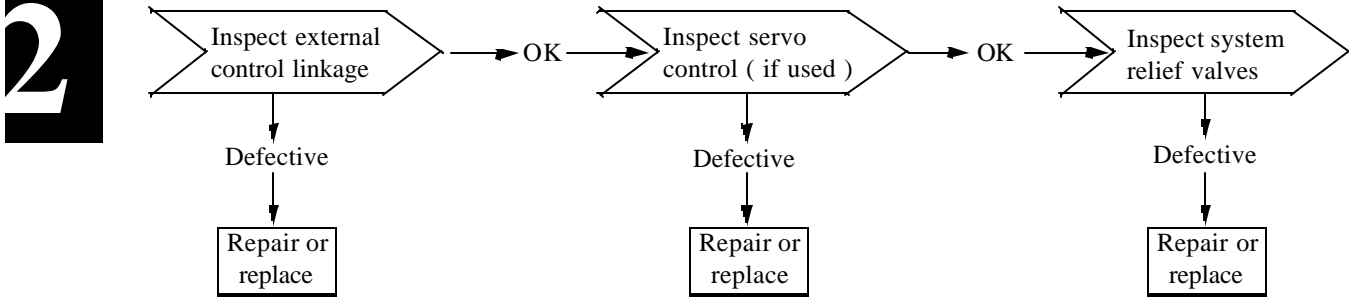

Symptom: System Response Sluggish

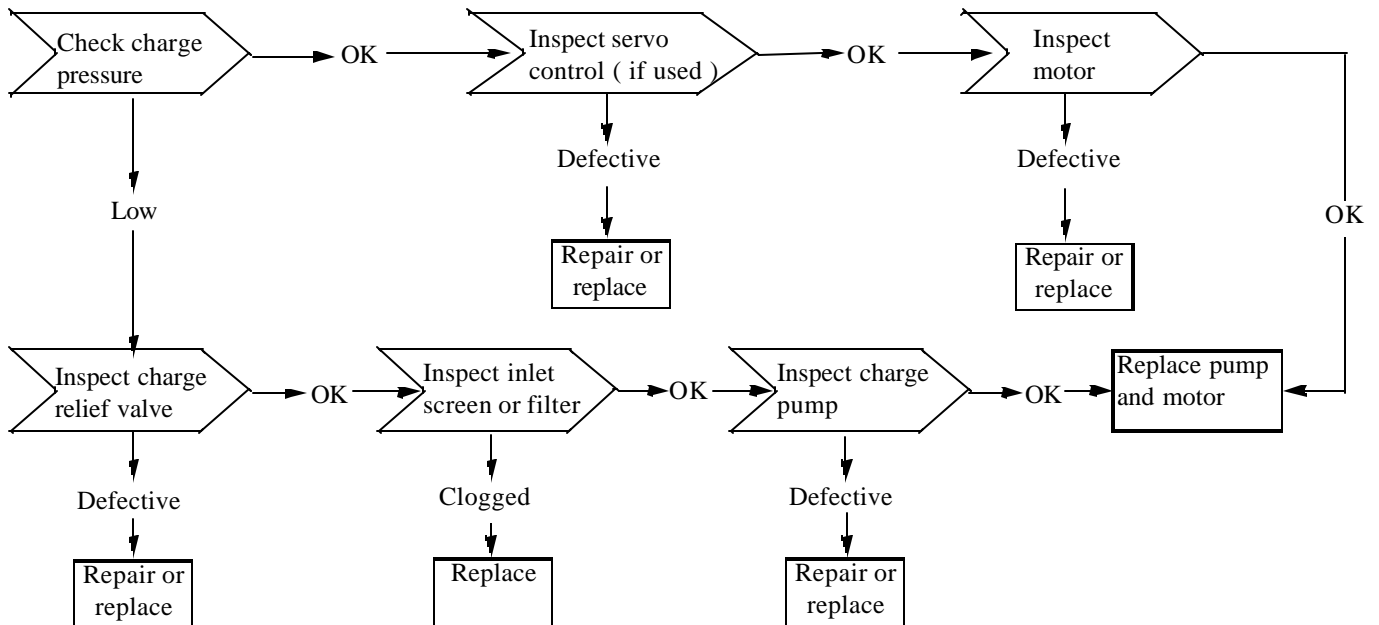

# TANDEM PUMP REPLACEMENT 2.10

## Removal

Begin the pump removal by removing any attachment, raise the boom arms and engage the boom support pins. Shut off the engine.

1 Remove the seat and hydrostatic shield.

2 Remove the steering lever linkage. Refer to section 4 for removal and replacement information.

3 Remove the gear pump as outlined in section 2.9.

4 Disconnect all the hydraulic hoses. (fig. C2359, C2610) Marking the hose and fitting location is recommended to ease re-assembly. Upon re-assembly, torque the hydraulic fittings and hoses as outlined in the Torque Chart in Section 8. Cap all open lines and ports.

5 Remove the hydraulic fittings from the tandem pump to prevent damage while removing pump. Plug all open ports and keep the fittings in a clean area. Inspect fittings and o-rings for damage, replace as required.

6 Loosen the mounting bolts retaining the tandem pump to the engine bellhousing. (fig. C2608, C2609).

7 Attach a lifting device to the tandem pump. The pump is fairly heavy, approximately 80 lbs. (36 Kg) It is highly recommended to use a mechanical lifting device to assist removal of the tandem pump.

8 Remove the 2 rear mounting bolts. (fig. C2608, C2609) Remove the tandem pump from the loader.

**Refer to the Sauer Sundstrand Repair Manual, (Thomas p / n 44232 or Sauer Sundstrand p /n BLN - 9992), for complete pump servicing.**

**Thomas does not cover or handle warranty processing or repair work performed on the Sauer Sundstrand product. Warranty work can only be approved and performed by an authorized Sauer Sundstrand dealer.**

High pressure hoses



Tandem case drain hose



C2359

2

# DRIVE MOTOR 2.12

2

The geroler (fig. C2299), is both a fluid displacement motor and a gear reducer. It provides 8 times (the number of star points) greater power per revolution than a gear, vane or piston type motor. This means that 8 times the greater torque can be developed at one eighth the speed without further gear reduction.

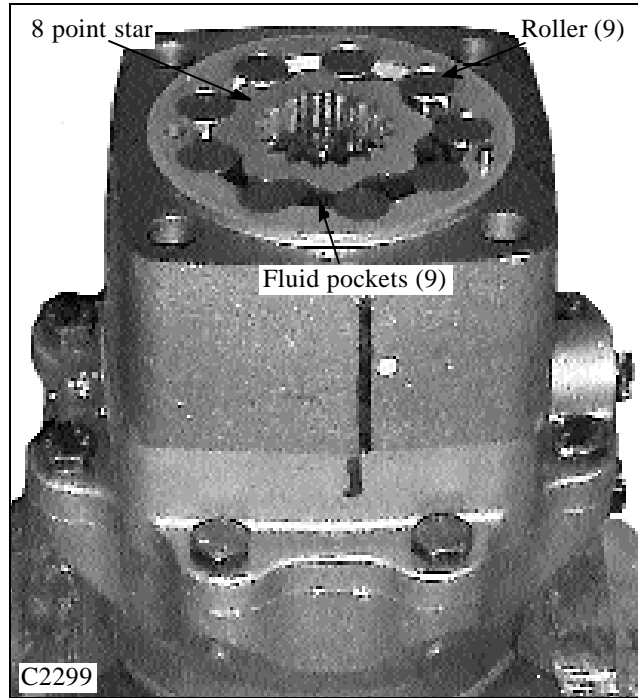

Example shown in fig. C166 is one complete star orbit, or one sixth of the output shaft rotation. The star must travel through 6 complete orbits for each single rotation of the output shaft creating a speed reduction of 6 to 1. The use of 7 fluid power pockets with the 6 to 1 ratio provides 42 fluid power cycles per each complete shaft revolution. **NOTE: Actual star point count is 8. This is only an example.**

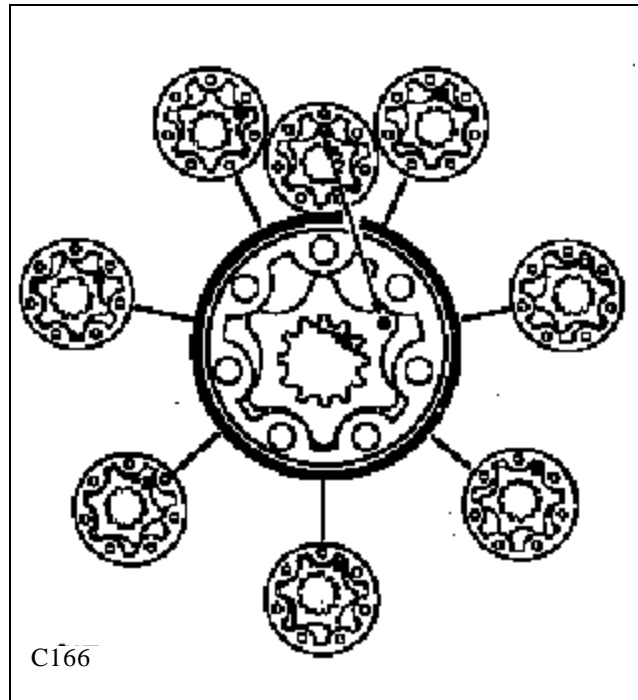

# DRIVE MOTOR 2.12

## Disassembly (cont'd)

9 Carefully lift the valve housing straight up. (fig. C2295) Place your fingers under the valve housing to hold the channel plate in place.

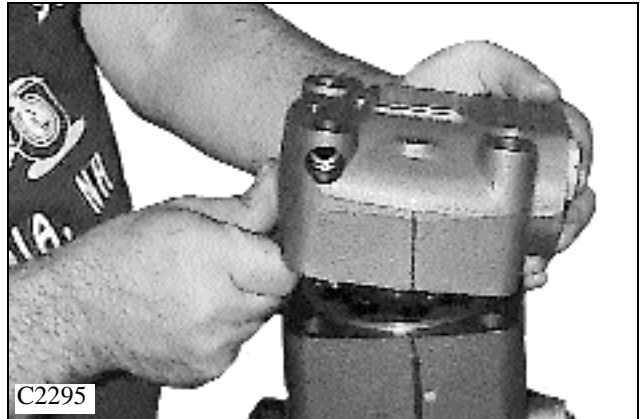

10 Remove the channel plate. (fig. C2296)

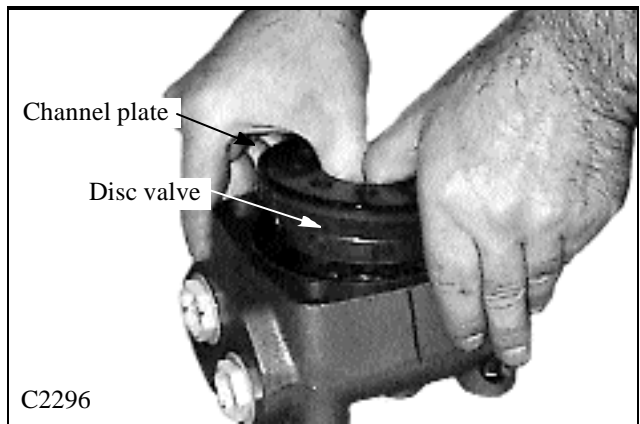

11 Remove the disc valve and balance plate from the valve housing section. (fig. C2297, C2298)

12 Inspect the parts for wear and replace as required. Replace all seals with new when assembling the drive motor.

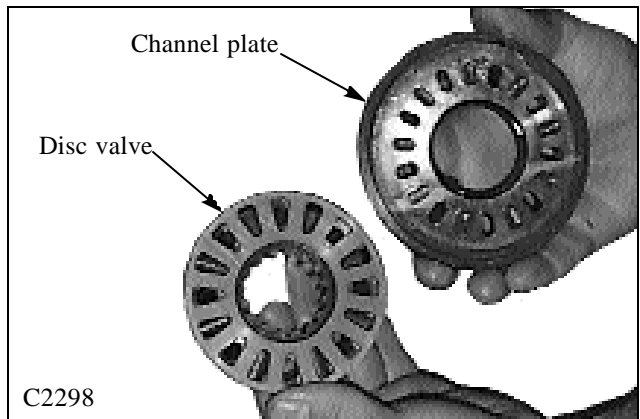
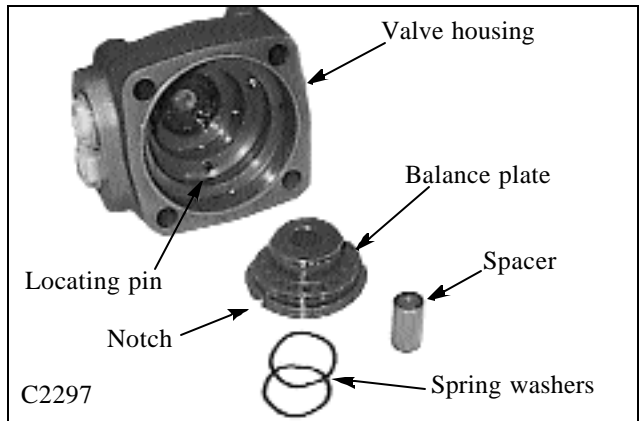

2

# DRIVE MOTOR 2.12

## Assembly (cont'd)

14 Install the geroler section the housing. (fig. C2330)  
Place a hand under the geroler to prevent the pieces from falling out.

2

**The following procedures must be followed closely for proper motor rotation.**

15 Mark the gearwheel set rotor at the point where the top of a spline tooth is opposite the bottom of a tooth in the external rotor teeth. (fig. C2331).

16 Mark the bottom of a spline tooth on the valve drive. (fig. C2332).

17 Install the valve drive lining up the marks on the valve drive to the gearwheel set. (fig. C2333).

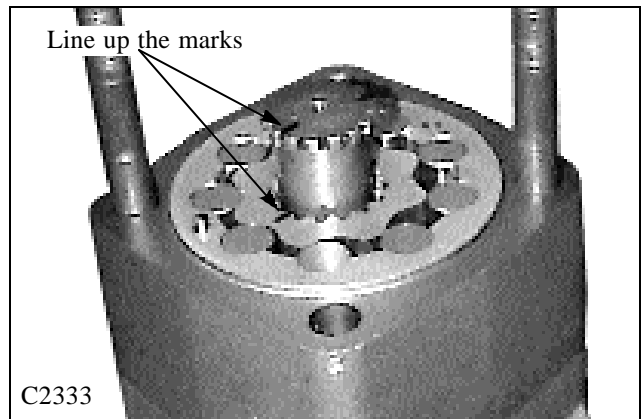
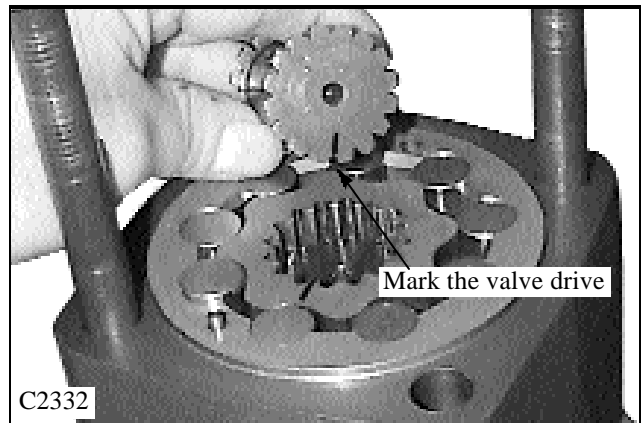
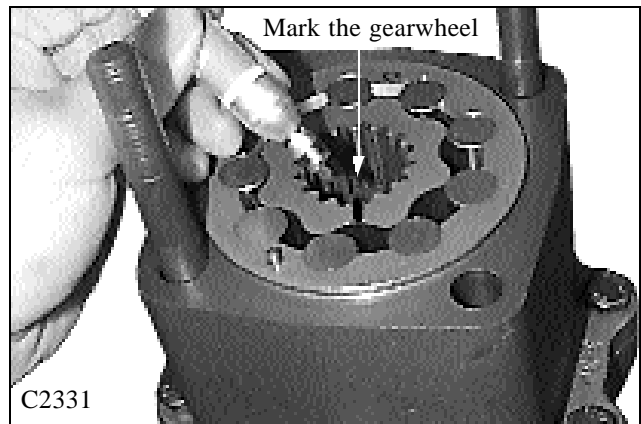
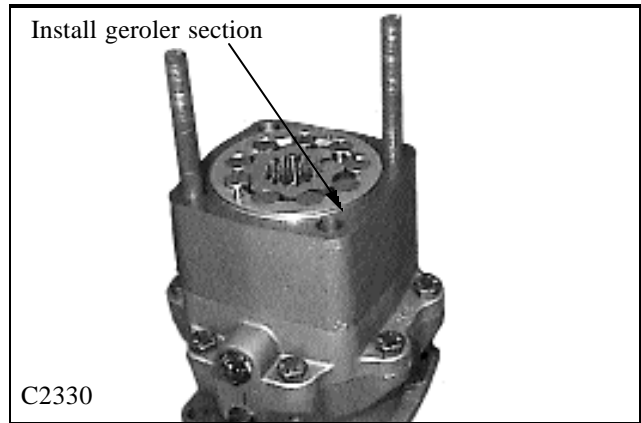

CLICK HERE TO **DOWNLOAD** THE COMPLETE MANUAL

- Thank you very much for reading the preview of the manual.
- You can download the complete manual from: [www.heydownloads.com](http://www.heydownloads.com) by clicking the link below



- Please note: If there is no response to CLICKING the link, please download this PDF first and then click on it.

CLICK HERE TO **DOWNLOAD** THE COMPLETE MANUAL

# DRIVE CHAIN 3.3

## Chain Installation

- 1 Wrap the chain in a “Z” pattern (fig. C2273).
- 2 Install the wrapped chain into the final drive housing.
- 3 Place one end of the chain over the top of the axle sprocket. Rotate the axle by hand and bring the chain along the bottom of the final drive housing to approximately the center.

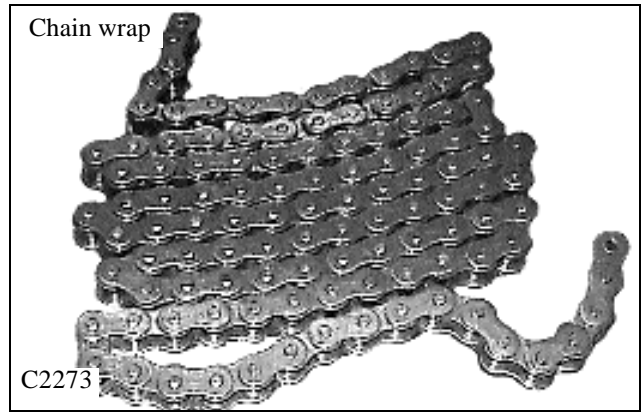

- 4 Wrap the chain around the drive motor sprocket and install a new connecting link (fig. C2427).

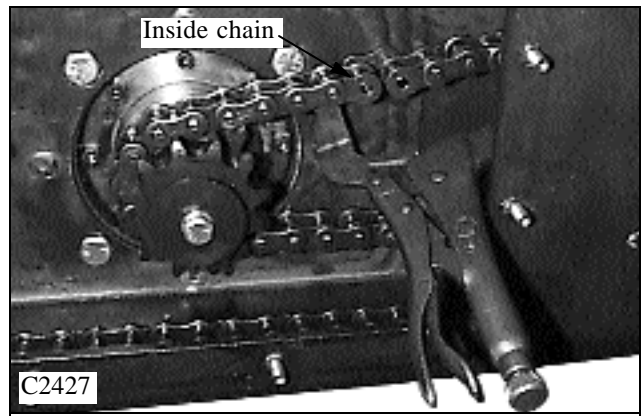

- 5 Place the connecting link into the chain so the inside chains connecting link has cotter pins face the inspection cover hole (fig. C2428). The connecting link on the outside chain, closest to the inspection cover opening, faces inward, (fig. C2429) toward the other chain. Bend the ends of the cotter pins at least 90° apart.

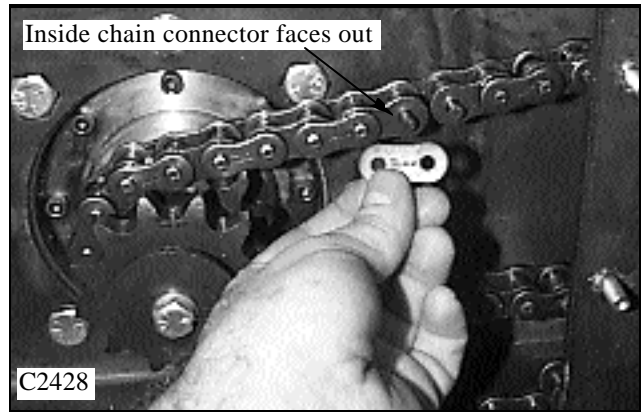

- 6 Check the chain tension as outlined on Section 3.3.

- 7 Replace the inspection cover using silicone. Do not over tighten the inspection cover nuts, 12 lbs / ft maximum. (16.5 nm). Be sure to clean sealing surfaces before silicone application.



- 8 Replace the wheels and torque the wheel nuts to 100 to 110 lbs/ft. (136 to 149 nm).

3

# TROUBLE SHOOTING 3.6

3

Problem	Cause	Corrective Action	Section
Final drive noisy.	No lubricating oil.	Check oil level. Add 10W30 SE/CD oil to correct level.	3.2
	Chain is loose.	Adjust the chain tension. Check chain tension every 150 hours.	3.3
	Axle has too much end play. (Bearing pre-load)	Check and adjust the bearing pe-load on the axle bearings	3.6
	Chain tightener damage or failure.	Inspect the chain tightener and repair if necessary.	3.4
No drive on one side.	Drive chain failure.	Inspect the drive chain and connecting link. Replace damaged parts. Check the chain tension every 150 hours.	3.3
	Drive motor sprocket failure	Inspect the drive sprocket and splines. Replace parts as required.	3.5 2
	Drive motor or hydrostatic system failure	Refer to the hydrostatic drive section. Diagnose and make repairs as required.	2
Lubrication oil leaking through the filler / breather cap.	Lubricating oil level too high.	Check the oil level.	3.2
	Drive motor shaft seal leakage.	Inspect and repair damaged parts.	2
Wheel studs shearing off.	Wheel nuts loose.	Replace the wheel studs. Check wheel nut torque daily. Torque wheel nuts at 100 to 110 lbs/ft. (135 to 149 nm)	3.6
Wheel stud threads stripped.	Wheel nuts over tightened.	Replace the wheel studs. Check wheel nut torque daily. Torque wheel nuts at 100 to 110 lbs/ft. (135 to 149 nm)	3.6

# FOOT PEDALS 4.2

## Cable Replacement

Check cable ends, eyelets or rod ends, and mounting pins for wear before removing the cable. Replace worn parts when replacing new cables. Cable ends should be inspected every 150 hours of operation.

- 1 Raise the boom arms, engage the boom supports and shut off the engine.

### WARNING

**Never work under the boom arms without the boom supports engaged.**

4

- 2 Remove the seat and hydrostatic shield.
- 3 Loosen the jam nuts on the cable clevis ends. (fig. C2440, C2367)
- 4 Loosen the cable nuts. (fig. C2439, C2367)
- 5 Remove the bolts retaining the bulk head mount to the frame plate. (fig. C2439)
- 6 Remove the cotter pins from both ends of the cables and remove the clevis pins. (fig. C2440, C2367)
- 7 Remove the cable.
- 8 Remove the clevis and eyelet ends of the cable and reuse them if still serviceable.
- 9 Install the new cable in the reverse order above. There must be a minimum of 3/8'' (6mm) of thread engagement into the cable clevis and eyelet ends.

**Note:** After installation of a new cable, the foot pedal angle will need to be verified and adjusted if necessary. Refer to page 4-11.

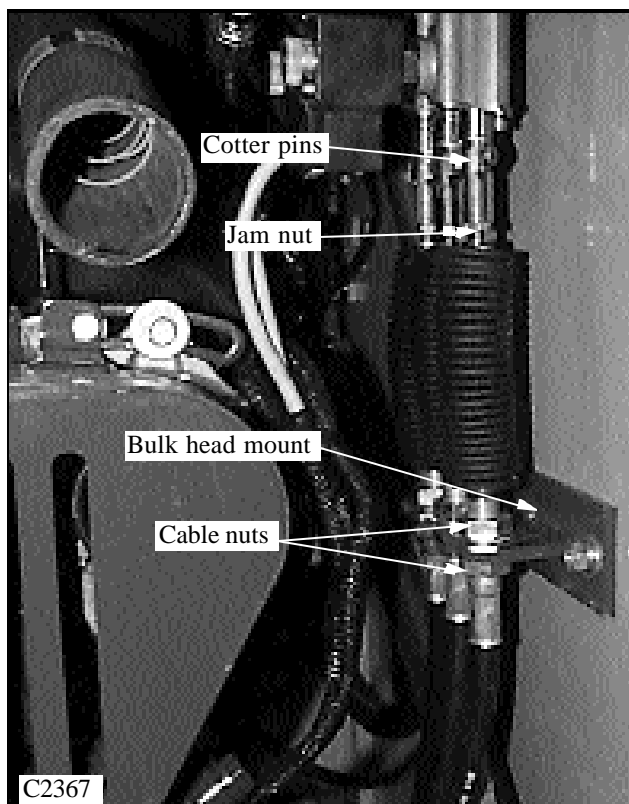
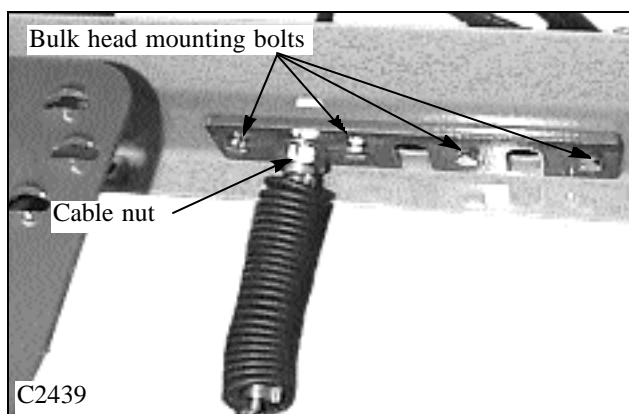
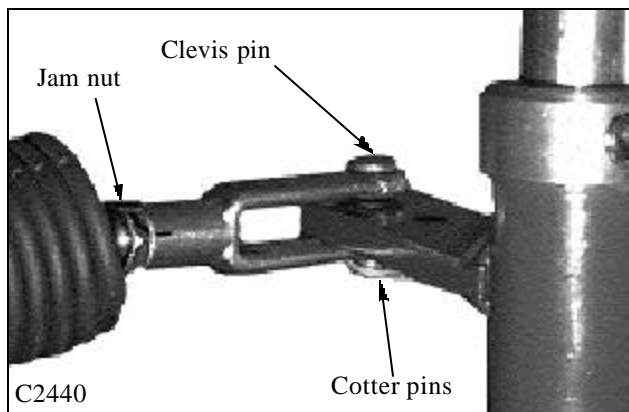

# THROTTLE 4.4

## Throttle Cable Replacement

1 Raise the boom arms, engage the boom supports and shut off the engine.

### WARNING

Never work under the boom arms without the boom supports engaged.

2 Remove the seat and hydrostatic shield. (fig. C806).

3 Loosen the set screw connecting the throttle cable to the throttle handle. (fig. C2363). Loosen the mounting nuts.

4 Open the rear door and loosen the set screw connecting the throttle cable to the engine lever. (fig. C2626). Loosen the mounting nuts.

5 Remove the throttle cable.

6 Replace the throttle cable in the reverse order above.

7 Adjust the cable as outlined in section 4.4 so the engine lever bumps the limiter bolts (fig. C2625) when the throttle lever is stroked full ahead (high idle) and full rearward (low idle).

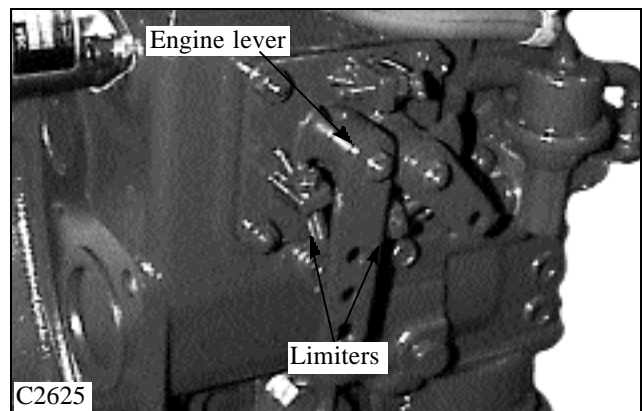
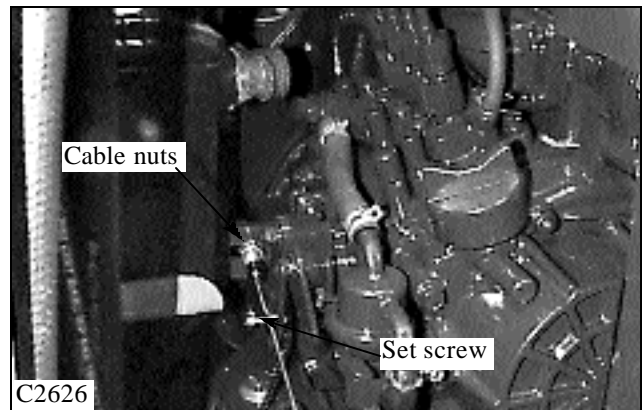
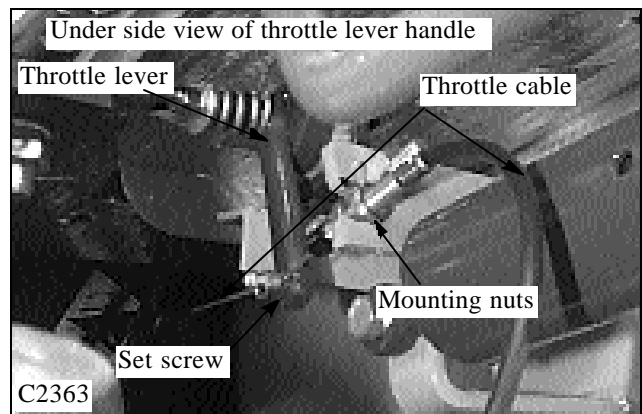

4

# WIRING SCHEMATIC 5.2

## Engine Harness Connector

Diagram C2459a Legend. Shown is the wire color and function of each pin terminal in the connector plug.

PIN	WIRE COLOR	FUNCTION
1	Tan	Starter relay
2	Blk / Wht	Fuse block
3	Red / Wht	Glow plug relay
4	White	Circuit breaker
5	Purple	Engine oil pressure
6	Pink	Air filter
7	Pple / Wht	Coolant temperature
8	Wht / Brn	Horn button
9	Brn / Wht	Brake light switch
10	Red / Org	Rear light
11	Org / Blue	Fuel level (+)
12	Blue / Wht	Hydraulic temperature
13	Grey / Wht	Alternator (L)
14	Grey	Seat Belt

C2459a

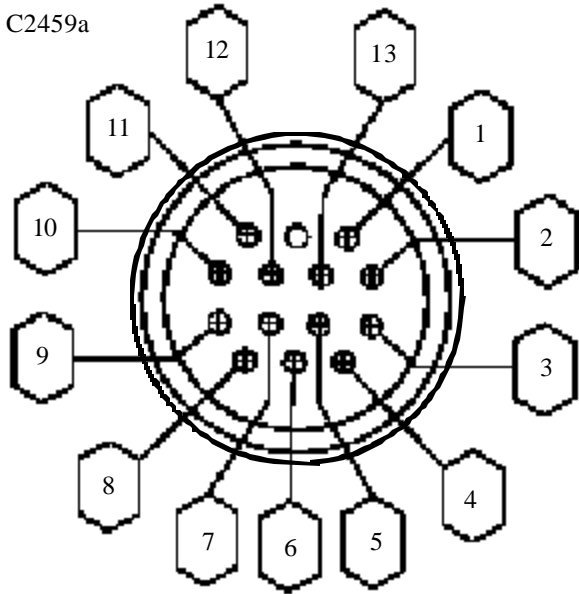

## ROPS Harness Connector

Diagram C2459 Legend. Shown is the wire color and function of each pin terminal in the connector plug.

PIN	WIRE COLOR	FUNCTION
1	Purple	Eng. oil press. indicator
2	Org / Blue	Fuel level (+) gauge
3	Grey	Charge (L) indicator
4	Grey / Wht	Brake light
5	Blue	Hyd. temp. indicator
6	Yl / Red	Spare
7	Wht / Brn	Horn
8	Brown	Aux. indicator
9	White / Pple	Spare
10	Red	Seat belt indicator
11	Tan	Ignition (50)
12	Red / Wht	Ignition (19, 17)
13	Pple / Wht	Coolant temp. indicator

C2459

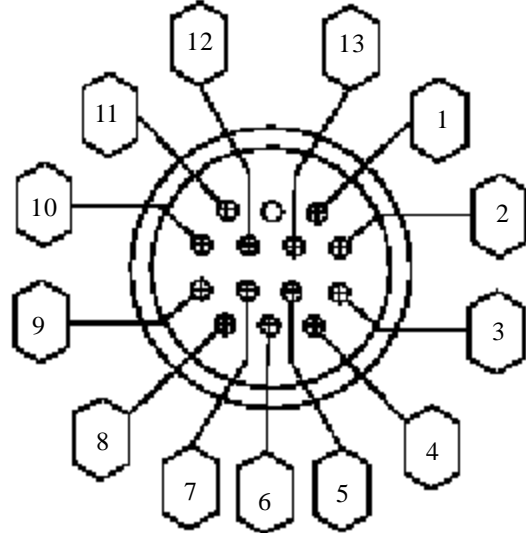

# BATTERY 5.6

## Removal and Inspection

9 Inspect the battery case for cracks that may allow electrolyte to leak into the environment. Inspect the batteries on a regular basis for damage such as cracks or a broken case. Inspect the battery cables for tightness and corrosion. Remove any corrosion and coat the terminals with a dielectric grease. Check the battery hold downs to be sure they are properly retaining the battery in the compartment. (fig. C1328)



## Boosting

In the event the loader has failed to start and requires boosting, a boosting lug or post is located in the engine compartment. (fig. C2347)

- 1 Open the rear door and raise the engine compartment cover.
- 2 Remove the red rubber protective cover from the boosting lug. (fig. C914)
- 3 The ignition must be in the off position.
- 4 Connect the positive cable from the 12 volt boosting supply to the boosting lug on the loader.
- 5 Connect the negative ground cable to the boosting supply first, and then to a clean ground on the loader engine. Keep the cables away from any moving parts.
- 6 Start the engine.
- 7 Remove the negative ground cable from the engine first and then the boosting supply. Remove the positive cable from the boosting lug.

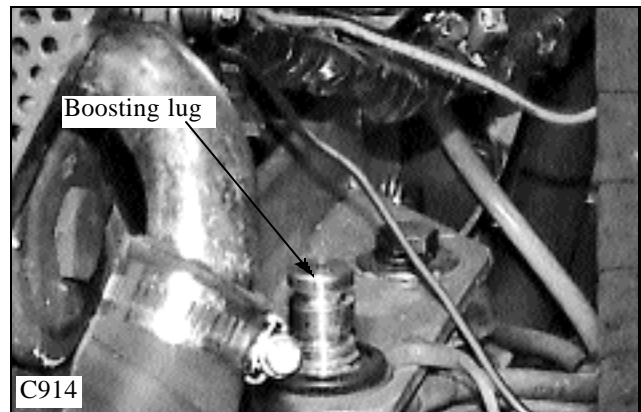
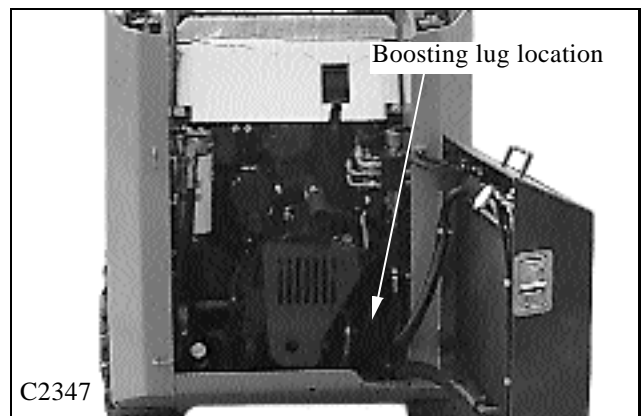

## Circuit Breaker

The circuit breaker is in the fuse panel, located in the engine compartment. (fig. C2484). See section 5.7.

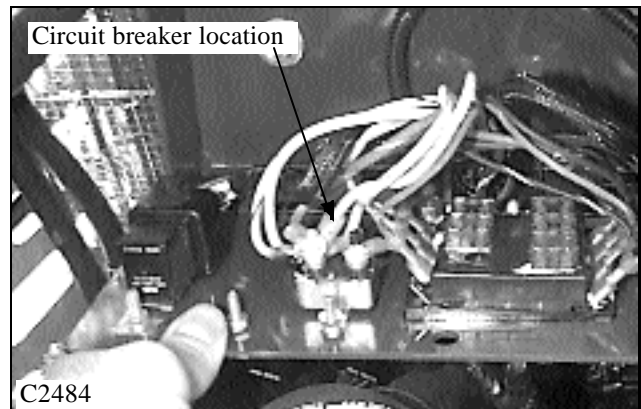

# ACCESSORIES CIRCUIT 5.13

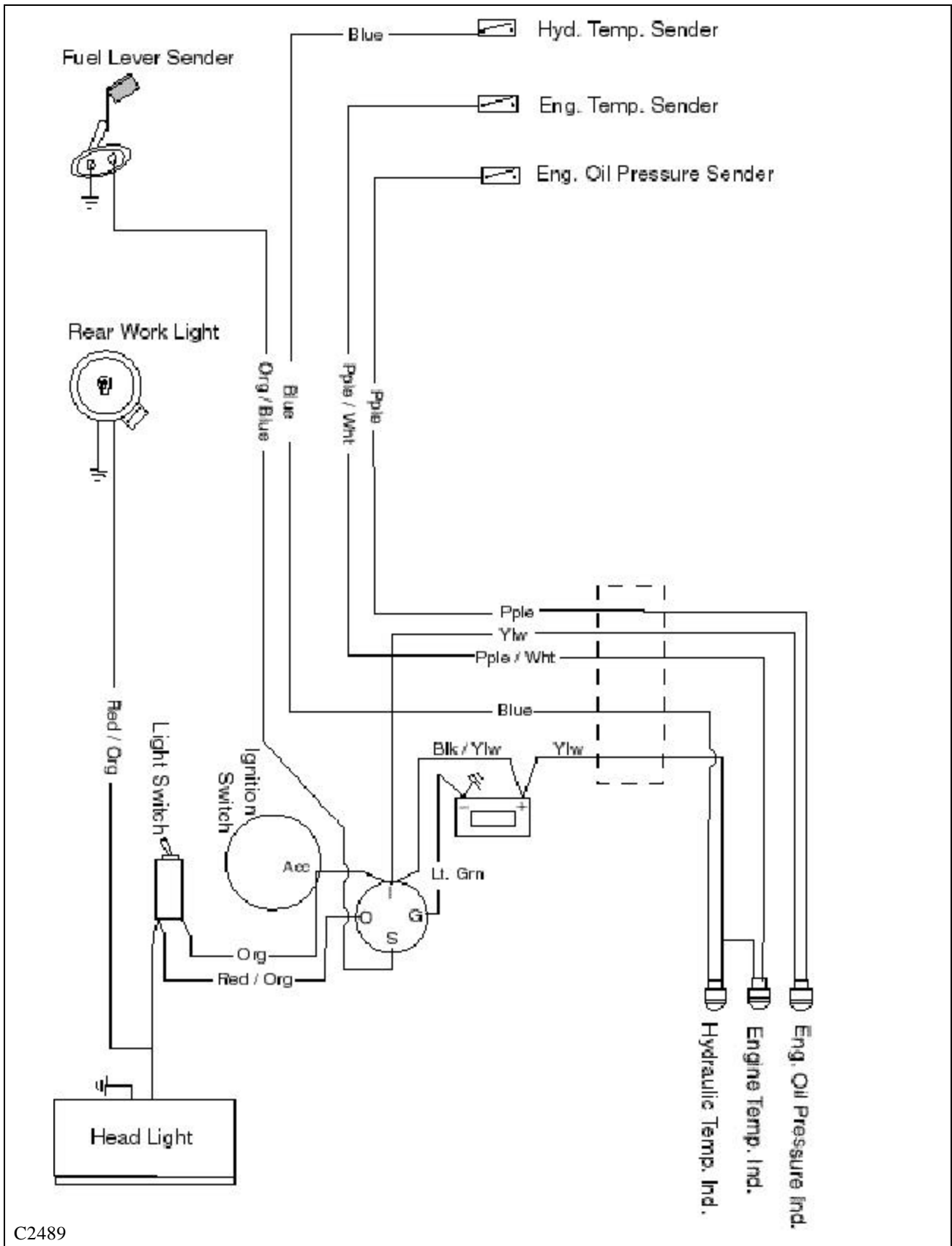

C2489



# BOOM SUPPORTS 6.3

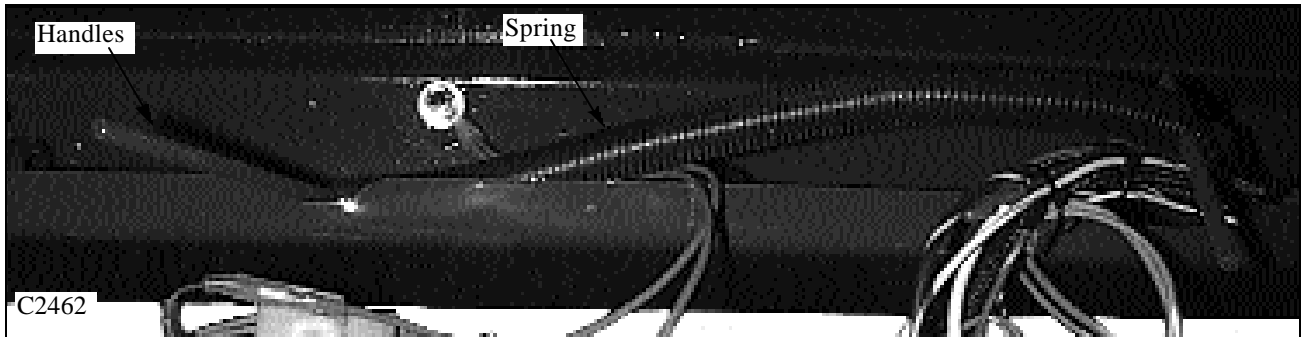
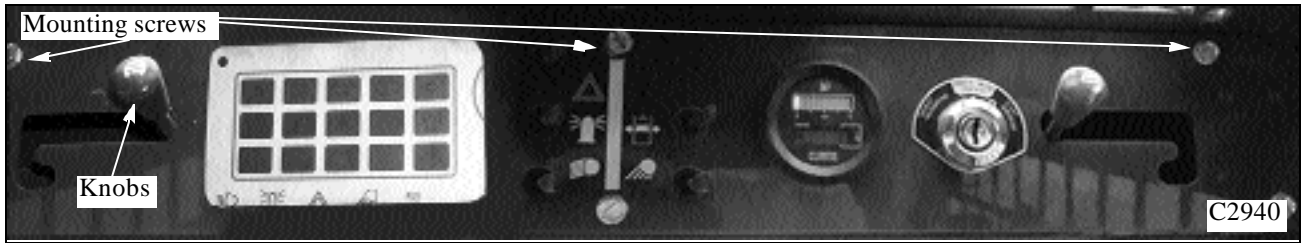

## Boom Arm Supports

For safety while performing regular service or maintenance work, the loader is equipped with boom supports. The boom supports, when extended, prevent the boom arm from lowering when servicing the loader. The boom supports should be greased every 8 hours of use and engagement depth should be checked every time the supports are used.

- 1 Raise the boom arms, extent the boom supports and allow the boom arms to lower onto the supports. Do not pressure the hydraulic system against the boom supports.
- 2 Shut off the engine and engage the parking brake.
- 3 Measure the distance the boom support pins are protruding past the inner boom arm plate. Proper adjustment should have the support pin protruding past the inner boom arm plate by **1/4 inch. (6.5mm)**. (fig. C1823).
- 4 Adjust the engagement depth by removing the 6 bolts on the dash panels to access the support pins and linkage. (fig. C2940, C2462)
- 5 Loosen the jam nut on the support pin linkage. (fig. C2628)
- 6 Screw the pin in or out the amount necessary to get the proper adjustment for support pin engagement on the boom arms.
- 7 Apply 242 Loctite (blue) to the nut and tighten it against the support pin when installing.
- 8 Lubricate the boom support pins and replace the dash panels.

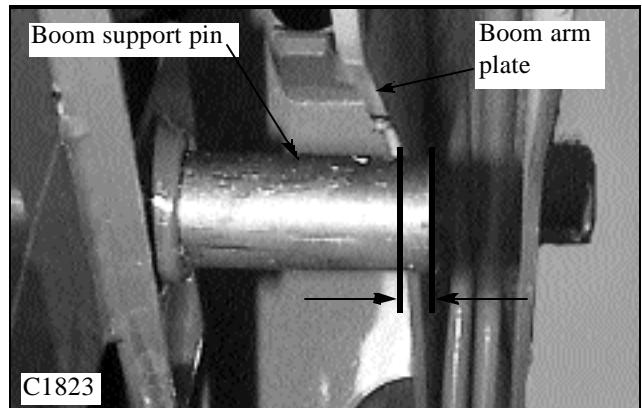
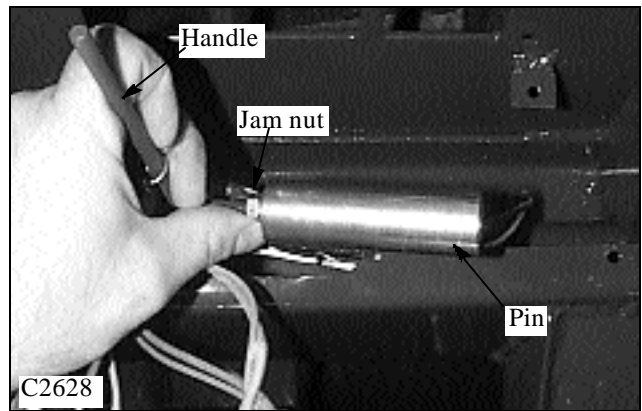

# ENGINE MAINTENANCE 7.1

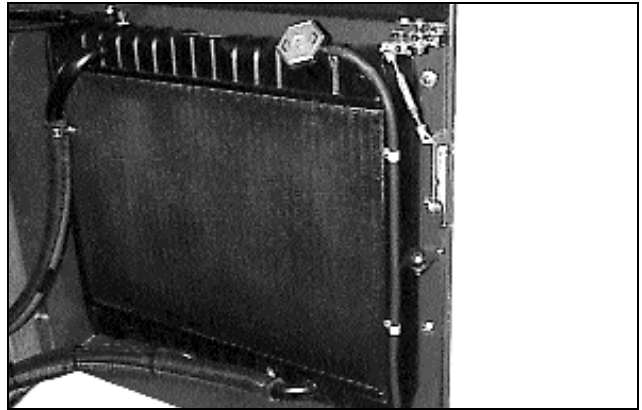

C2499

# ENGINE SPECIFICATIONS 7.4

Make and model .....	Kubota V1305E
Type .....	Vertical , In Line, 4 Cycle
Number of cylinders .....	4 (four)
Displacement .....	1335cc (81.5 cu. in.)
Cylinder bore .....	76 mm (2.99 inches)
..... Allowable limit: 76.0 ~ 76.019mm + 0.15mm. (2.9921 ~ 2.9929 + 0.0059 inches)	
..... Oversize Cylinder Bore +0.5mm (0.0197 inches)	
Ring Gap .....	Allowable Service Limit 1.25mm (0.0492 inches)
Top Compression Ring .....	0.25 ~ 0.40mm (0.0098 ~ 0.0157 inches)
Second Compression Ring .....	0.25 ~ 0.40mm (0.0098 ~ 0.0157 inches)
Oil Ring .....	0.25 ~ 0.40mm (0.0098 ~ 0.0157 inches)
Stroke .....	73.6 mm (2.9 inches)
Bearing clearance .....	Main journals: 0.04 ~ 0.118mm (0.0006 ~ 0.0015 in) < 0.2 mm (0.0079 in) allowable limit >
..... Rod journals: 0.025 ~ 0.087 mm (0.0009 ~ 0.0034 in) < 0.2 mm (0.0079 in) allowable limit >	
..... Thrust bearing end play: 0.15 ~ 0.31 mm (0.0059 ~ 0.0122 in) < 0.5 mm (0.0197 in) allowable limit	
Maximum engine speed (no load) .....	3000 RPM
Low idle setting .....	1300 RPM
Cooling system .....	Liquid
Cold starting aid .....	Glow plug in combustion chamber
Power (ISO 9249 Net Power) .....	22.5Kw (30 hp) @ 3000 RPM
Torque (ISO 9249 Net Power) .....	6 kg /m. (43.4 lbs / ft.) @ 2400 RPM
Compression ratio .....	22.0: 1
Engine compression .....	29 - 33kgf / cm <sup>2</sup> (412 - 469psi)
..... Service limit: 23kgf / cm <sup>3</sup> (327psi) 10 % variance among cylinders	
Firing order (viewed from gear case end) .....	1 - 3 - 4 - 2
Fuel injection pump .....	Bosch MD type mini pump
Fuel injection timing .....	21° ~ 23° BTDC (0.37 ~ 0.40 Rad)
Injector working pressure .....	140 - 150 kgf / cm <sup>3</sup> (1990 - 2133 psi)
Direction of rotation (viewed from flywheel end) .....	Counter - clockwise
Location of timing marks .....	N / A
Valve clearance, (cold) .....	0.145 - 0.185 mm (0.0057 - 0.0072 in)
Valve seat angle .....	Intake 1.047 Rad (60°)
..... Exhaust 0.785 Rad (45°)	
Valve seat width .....	Intake 2.12mm (0.0835 in)
..... Exhaust 2.12mm (0.0835 in)	
Valve face angle .....	Intake 1.047 Rad (60°)
..... Exhaust 0.785 Rad (45°)	
Valve recessing .....	- 0.05mm ~ 0.4mm (0.0020 ~ 0.016in)









# MAINTENANCE 8.1



**8**

# THOMAS

# SPECIAL TOOLS 8.3

P / N	Illustration	Description	Model
916-30042-01 25197		<p>DRY LINER PULLER - Used for removing and installing the dry liner of the engine.</p> <p>Consists of:            304742 (64mm); 304743 (68mm); 30744 (75mm)            304745 (76mm); 304746 (82mm); 304747 (105mm); Removing Plates; 304748 Installing Plate</p>	Kubota
07909-30202-01 25198		<p>DIESEL ENGINE COMPRESSION TESTER - Used to measure diesel engine compression and diagnosis of need for major overhaul.</p>	Kubota
07916-30820-01 25199		<p>CRANKSHAFT NUT SOCKET - Used to take off and fix the crankshaft nut. (46 mm).</p>	Kubota
07916-30840-01 25200		<p>NOZZLE REMOVER SOCKET - Used to unfasten the screw type nozzle holders.</p>	Kubota
70090-01125-01 25201		<p>NOZZLE DISASSEMBLY SOCKET - Used in place of a vice for disassembly and repair of nozzles.</p>	Kubota
960456		<p>HYDRAULIC FLOW AND PRESSURE GAUGE ASSEMBLY.</p>	All Loaders

CLICK HERE TO **DOWNLOAD** THE COMPLETE MANUAL

- Thank you very much for reading the preview of the manual.
- You can download the complete manual from: [www.heydownloads.com](http://www.heydownloads.com) by clicking the link below



- Please note: If there is no response to CLICKING the link, please download this PDF first and then click on it.

CLICK HERE TO **DOWNLOAD** THE COMPLETE MANUAL